

Senior Design 1
Spring 2021

Concentrating System

Batz, Zoe (Electrical Engineering)
Brown, Mitchell (Electrical Engineering)
Cella, Daniel (Electrical Engineering)
Kajee, Yusuf (Computer Engineering)

Department of Electrical and Computer Engineering
University of Central Florida
Dr. Samuel Richie

Table of Contents

Table of Contents	1
1.0 Executive Summary	8
2.0 Project Description	10
2.1 Project Motivation and Goals	10
2.2 Deliverables	11
2.3 Agile	11
2.4 Requirement Specifications	12
2.4.1 Eye-Tracking Specifications	13
2.4.2 Weight Specifications	14
2.4.3 Safety Specifications	14
2.4.4 Wireless Communication System Specifications	15
2.4.5 User Interface Specifications	15
2.4.6: Accessibility Specifications	15
2.4.7 Hardware Specifications	16
2.5 Constraints	16
2.5.1 Hardware Constraints	17
2.5.1.1 Weight Sensor Constraints	17
2.5.1.2 Vibration Mechanism Constraints	17
2.5.1.3 Computational Device Constraints	17
2.5.2 Software Constraints	18
2.5.3 Safety Constraints	18
2.5.4 Presentation Constraints	18
2.5.5 Energy Constraint	19
2.5.6 Ethical Constraints	20
2.5.7 Environmental Constraints	21
2.5.8 Economic and Time Constraints	21
2.6 House of Quality Analysis	21
2.7 Decision Matrix	23
2.8 Project Measurables	25
2.9 Stretch Goals	26
3.0 Research and Investigation	27
3.1 Existing Similar Projects and Products in the Market	28
3.2 Computational Devices	29
3.2.1 Single Board Computers	30
3.2.2 Microcontroller Units	30
3.2.3 Texas Instruments MSP430	31

3.2.3.1 MSP430G2553	31
3.2.3.2 MSP430FR6989	31
3.2.4 nRF52840	31
3.2.5 Raspberry Pi	31
3.2.5.1 Raspberry Pi Zero	32
3.2.5.2 Raspberry Pi 4B	32
3.2.5.3 Raspberry Pi Pico	32
3.2.6 Comparison	32
3.2.7 Computational Device Conclusion	33
3.2.7.1 Main Communication Module	33
3.2.7.2 Secondary Module	33
3.2.8 Lockbox Electromagnet Microcontroller Option	33
3.3 Sensors	34
3.3.1 Weight Sensor	35
3.3.1.1 Chair Weight Sensor	35
3.3.1.1.1 Velostat Weight Sensor	35
3.3.1.1.2 FlexiForce Sensors	36
3.3.1.1.3 Strain Gauge Load Cells	36
3.3.1.2 Phone Lock Box Weight Sensor	36
3.3.1.2.1 Homemade Weight Sensor	36
3.3.1.2.2 Commercial Weight Sensors	37
3.3.2 Camera Sensor	37
3.4 Communication Module	42
3.4.1 Wireless Communication	42
3.4.1.1 Wireless Communication Hardware	43
3.4.1.1.1 HC-05	43
3.4.1.1.2 Bluefruit LE SPI (or UART) Friend	44
3.4.1.1.3 HM-10	45
3.4.1.1.4 Wireless Communication Module Comparison	45
3.4.2 Wired Communication	45
3.4.2.1: UART	45
3.4.2.2: I2C	46
3.4.2.3 SPI	47
3.5 Vibration Module	47
3.5.1 Coin Vibration Motors	47
3.5.2 Linear Resonant Actuator	48
3.5.3 Cylindrical Vibrating Motor	48
3.6 Smart Locking Mechanism	48
3.6.1 Classification of Smart Locking Systems	49
3.6.1.1 Original Claim Modifications	49
3.6.2 Types of Electronic Locking Mechanisms	50

3.6.2.1 Electronic Deadbolt Lock	50
3.6.2.2 Electromagnetic Lock	51
3.6.2.3 Delayed Egress Magnetic Lock	52
3.6.2.4 Potential Electromagnetic Locking Issues	52
3.7 Power Supply and Battery Storage Systems	53
3.7.1 USB Power Supply	53
3.7.2 Energy Storage Systems	53
3.7.3 Battery Types and Sizing	54
3.7.4 Battery State Of Charge Measurements	56
3.7.5 Battery Management Systems	57
3.7.6 Battery Charging Methods	59
3.7.7 AC/DC inclusion investigation	59
3.8 Lights/Displays	60
3.9 Switches	60
3.9.1 Electromagnetic Switches	61
3.9.2 Relays	61
3.9.3 Power MOSFET Transistors	62
3.10 Diodes	63
3.11 Voltage Regulators	64
3.11.1 Linear Voltage Regulators	64
3.11.1.1 Standard Voltage Regulator	65
3.11.1.1.2 Low Drop-Out Regulator	66
3.11.1.1.3 Quasi Low Drop-Out Regulator	66
3.11.2 Switching Voltage Regulator	67
3.11.2.1 Buck & Boost Voltage Regulators	67
3.11.3 Voltage Regulator Chart Comparisons	68
4.0 Standards	70
4.1 Standards of Electricity	70
4.2 PCB Standards	73
4.2.1 PCB Design Software Selection	74
4.2.2 PCB Manufacturer Selection	75
4.3 Power Supply Standards	75
4.3.1 Battery Pack Standards	76
4.3.1.1 IEEE standard 1625-2004	76
4.3.1.2 IEEE Standard 1635-2018	76
4.3.2 USB Standards	77
4.4 Legal Standards	77
4.5 Security Standards	78
4.6 Programming Software Standards	78
4.6.1 IEEE 29114-4	79

4.6.2 IEEE 15939	79
4.6.3 IEEE 26515-2018 Systems and Software Engineering - Developing information for users in an agile environment	80
4.7 Wireless Communication Standards	80
4.8 Electromagnetic Locking Standards	81
4.8.1 IEEE Standard C95.1-2019	81
4.8.2 MIL-STD 464	82
5.0 Hardware	82
5.1 Hardware Design Summary	82
5.2 Prototype Sketches	83
5.2.1 Overall Apparatus	83
5.2.2 Smart-Locking System Prototype Sketch	84
5.2.3 Vibration Chair Module Prototype Sketch	85
5.3 Hardware Block Diagram	86
5.4 Computational Modules	87
5.4.1 Main Computational Module	87
5.4.1.1 Connection to Electromagnetic Lock	89
5.4.1.2 Connection to Phone Weight Sensor	89
5.4.1.3 Connection to Status Light	89
5.4.2 Secondary Computational Module	89
5.4.2.1 Connection to Vibration Mechanism	90
5.4.2.2 Connection to Chair Weight Sensors	91
5.4.3 Wireless Communication Modules	91
5.5 Desk Chair Enhancements	92
5.5.1 General Chair Module Flow Diagram	93
5.5.2 Vibration Mechanism	93
5.5.3 Weight Sensor	94
5.5.4 Power Source	96
5.5.5 Mounting Apparatus	97
5.6 Phone Locking System	98
5.6.1: General Lock-Box Logic Flow Diagram	98
5.6.2 Lock Box	99
5.6.3 Smart Locking System/Power Design	100
5.6.4 Weight Sensor	102
5.6.5 Status Light	103
5.7 Potential Hardware Issues	104
5.8 Additional Hardware Features	105
6.0 Software	105
6.1 Software Design Summary	106
6.2 Software Block Diagram	106

6.3 Algorithm Description	107
6.4 Necessary Functions	108
6.5 Necessary Data Structures	109
6.6 Software Flow	109
6.7 Choosing the Right Software	110
6.8 User Interface Overview	111
6.9 User Control and Security	113
6.10 Class Diagram	113
6.11 Potential Software Issues	115
6.12 Additional Software Features	115
7.0 Testing and Troubleshooting	116
7.1 Testing	116
7.1.1 Power Testing	117
7.1.1.1: Chair Power Testing	117
7.1.1.2: Smart Lock System Power Testing	118
7.1.2 Hardware Testing	118
7.1.2.1 Vibration Module Testing	119
7.1.2.2 Smart Lock Testing	119
7.1.2.3 Weight Sensor Testing	120
7.1.2.3.1 Lock Box Weight Sensor Testing	120
7.1.2.3.2 Chair Weight Sensor Testing	121
7.1.2.4 Computational Device Testing	121
7.1.2.4.1 Main Computational Device Testing	121
7.1.2.4.2 Secondary Computational Device Testing	122
7.1.2.4.3 Wireless Communication Device Testing	122
7.1.2.5: Power MOSFET Testing	123
7.1.3 Software Testing	123
7.1.3.1 Eye Tracker Compatibility Testing	123
7.1.3.2 Eye Tracker Functionality Testing	124
7.1.3.3 User Interface Functionality Testing	125
7.1.3.4 User Interface User Friendliness Testing	126
7.2 Troubleshooting	126
8.0 Administrative Content	127
8.1 Milestone Discussion	128
8.2 Project Economics	129
8.2.1 Budget Projections (initial)	130
8.2.2 Financial Decisions and Expenditures (as of Senior Design 1)	131
9.0 Team Collaboration	133
9.1 Discord	133
9.2 Zoom	133

9.3 Google Drive	134
10.0 Appendices	135
10.1 Appendix A: References	135
10.2 Appendix B: Visuals Permission Requests	136

List Of Images

- [Figure 1. House of Quality](#)
- [Figure 2. House of Quality Key](#)
- [Figure 3. Computational Device Comparison Chart](#)
- [Figure 4. SONOFF SV microcontroller board \(permission pending\)](#)
- [Figure 5. John Evans wearing his infrared eye tracking goggles](#)
- [Figure 6. The infrared eye tracking goggles as designed by John Evans. side view](#)
- [Figure 7. Tobii Eye Tracker 5](#)
- [Figure 8. The Tobii Eye Tracker 5 attaches to the monitor at the bottom](#)
- [Figure 9. Wireless Communication Module Comparison Chart](#)
- [Figure 10. Example of Electronic Deadbolt Lock with Included Keypad for Safety](#)
- [Figure 11. Image of a Typical Electromagnetic Lock](#)
- [Figure 12. Battery Balancing: Balanced vs Unbalanced](#)
- [Figure 13. Sample of a Series Linear Voltage Regulator](#)
- [Figure 14. Buck Voltage Switching Regulator](#)
- [Figure 15. Boost Voltage Switching Regulator](#)
- [Figure 16. Overall Ecosystem Prototype Sketch](#)
- [Figure 17. Smart Lock Box System Prototype Sketch](#)
- [Figure 18. Chair Vibration Module Prototype Sketch](#)
- [Figure 19. Block Diagram of Hardware Components](#)
- [Figure 20. LanchPad Development Kit](#)
- [Figure 21. Maglock Microcontroller pin layout](#)
- [Figure 22. MSP-EXP430G2ET LaunchPad Development Kit](#)
- [Figure 23. Chair Microcontroller Pin Layout and Powering](#)
- [Figure 24. Pins on HX711 Amplifier](#)
- [Figure 25. Weight Sensor Amplifying Circuit](#)
- [Figure 26. HC-05 Bluetooth Module Pinout](#)
- [Figure 27. Bluetooth Module Pin Layout for Chair Module and Maglock Module.](#)
- [Figure 28. Block Diagram for Chair Module](#)
- [Figure 29. Encased Vibration Motor](#)
- [Figure 30. pcs 50kg Load Cell Half-Bridge Human Body Scale Weight Weighing Sensor + 1pc HX711 Amplifier AD Module for Arduino](#)
- [Figure 31. Vibration Module Power Circuit with Motor Activation Circuit](#)
- [Figure 32. Smart Lock Box Logic Flow Diagram](#)
- [Figure 33. V Electromagnet](#)
- [Figure 34. V 2A ACDC adapter with connector pin](#)
- [Figure 35. Magnetic Locking Switch Apparatus with Power MOSFET Integration](#)

- [Figure 36. Deconstructed Velostat Weight Sensor](#)
- [Figure 37. LED notification circuit](#)
- [Figure 38. USB Circuit Diagrams for Both Modules](#)
- [Figure 39. Block Diagram of Software Components](#)
- [Figure 40. Minimal Design for the Web App](#)
- [Figure 42. Tobii Experience Troubleshooting Options](#)
- [Figure 43. SONOFF SV Image Request](#)
- [Figure 45. Tobi Image Request/Confirmation](#)
- [Figure 45. Tobi Image Request/Confirmation](#)
- [Figure 46. Milocks Image Request](#)
- [Figure 47. Locksmith Ledger International Image Request](#)
- [Figure 48. Battery Balancing Educational Image Request](#)
- [Figure 49. electrical4u.com Regulator Image Requests](#)
- [Figure 50. Texas Instruments Image Requests](#)
- [Figure 51. Bluetooth Module Image Requests](#)
- [Figure 52. Load Cell Weight Sensor Image Request Confirmation](#)

List Of Tables

- [Table 1. Brief Requirement Specifications Table](#)
- [Table 2. Decision Matrix](#)
- [Table 3. Decision Matrix Key](#)
- [Table 4. HC-05 Pin Configurations](#)
- [Table 5. Battery Comparison Chart](#)
- [Table 6. Power MOSFET Comparison Guide](#)
- [Table 7. Regulator Comparison Table](#)
- [Table 8. Sold Foreign Body IP Code Classification Table](#)
- [Table 9. Liquid Immersion IP Code Classification Table](#)
- [Table 10. Mechanical Impacts IP Code Classification Table](#)
- [Table 11. PCB Software Decision Table](#)
- [Table 12. PCB Manufacturer Decision Table](#)
- [Table 13. Table comparing programming languages](#)
- [Table 14. Estimated State of Charge Voltage Values for 1.5V batteries](#)
- [Table 15. Senior Design 1 Deliverables](#)
- [Table 16. Senior Design 1 Team Goals](#)
- [Table 17. Senior Design 1 Technical Goals](#)
- [Table 18. Senior Design 2 Milestones](#)
- [Table 19. Budget Projections](#)
- [Table 20. Total Cost Analysis at End of Senior Design 1](#)

1.0 Executive Summary

The integration of technology into everyday life has been beneficial in many ways: people have the ability to search information quickly, to connect with people from all around the globe with the click of a button, and to efficiently automate tasks. Most people are all too familiar with sitting at a desk in front of a computer or laptop, trying to focus on the task at hand, whether that be studying, working or taking an online class. It is far too easy to get distracted by our smartphones or anything going on around us. To aid in maintaining one's focus on the desired task, we are introducing a product that will combine eye tracking technology with weight sensors and a vibration mechanism to alert the user when their focus has drifted. In addition to this, we will use an electromagnetic locking system to contain a person's phone to keep them free of distraction while they work.

The eye tracking system is a primary tool in our design. When the eye tracking system does not detect the user's attention, the software will initiate an alert to the user to notify them that they lost focus. There will be a main computational device directly connected to the user's computer/laptop that will communicate wirelessly to a second computational device on the user's chair. The main computational device will be in charge of most of the processing being done. This device will also be directly connected to the lock box to confirm when a user's phone is inside and the lock should activate. There will be a weight sensor in the lock box to detect when the user's phone is placed inside, at which point the locking system can be activated. A status light on the outside of the box will indicate whether the box is locked or unlocked. In case of an emergency that will require the user to remove their phone from the lock box, a quick release switch will be added.

The chair module will be the part of our design that gives the user the alert from the eye tracking software when they have lost focus. This module will be designed so that it can be used on all types of desk chairs rather than being built into a single chair. The chair module will consist of two main parts, a seat cushion with added components and a secondary mounting apparatus that will contain the secondary computational device of the system. The seat of the chair module will contain a weight sensor that will be used to determine when the user is seated in the chair. This information will be used to determine when the user is ready to begin their productivity session and will activate the eye tracking system. To alert the user, a series of vibration motors will be placed in the seat of the chair module. When the eye tracker has determined that the user's focus has wandered for a set period of time, the vibration motors will activate to alert the user that they need to regain their focus. The weight sensor and the vibration motors will be connected to the secondary computational device in order to communicate wirelessly

with the main computational device. This device will be contained in a mounting apparatus that will be placed on the back of the chair. Included in this mounting apparatus will also be a power source that will provide the power for the main electrical components of the chair module.

The user will have access to a main menu in which they can turn the system on or off, along with other settings adjustments. In this menu, the user will be able to see the settings for the eye tracking software, smart lock box and mechanisms on the chair module. This menu will be a web app written primarily in Java, though additional languages will likely be needed to communicate with the computational devices. The web app should allow the user to personalize their experience to fit their needs. The eye tracking system will need to be calibrated for it to perform effectively. The user will be able to choose a certain portion of the screen they would like to focus on, meaning the eye tracking should be able to determine not just when they are looking at the overall screen but which part specifically. The main goal of our design is to help the user maintain their focus and regain it if they become distracted. If the user is watching a lecture or working solely on their computer, they shouldn't need to look away from their screen for very long. In this case, the allowed time for lost focus should be minimal. On the other hand, if the user is doing homework or taking notes from a video, they will need more time to look away from their screen to write in a notebook. In this case, the user will be able to adjust the allotted time looking away from the screen to a longer period. The user will also be able to set how long they would like to study before a quick break.

Apart from the eye tracking system settings, the user should be able to access controls for the smart lock box and chair mechanisms. In terms of the smart lock box, there will be an emergency release button so the user can remove their phone promptly if needed. The user may also be able to adjust how long their break time is, meaning how long the lock will remain open with access to their phone before it is time to return their focus to their computer. The vibration mechanism in the chair module may also have a few setting options. The strength, the speed and the time duration of the vibration in response to the user's focus drifting may be customizable.

A few other goals in regard to this software would be data tracking and parental controls. It might be helpful to the user to look back at their session to see how many times they lost focus or how many times they used the emergency release on the lock box. If a parent wished to use this system to help their children focus, they could lock their desired settings so the child could not adjust them.

This system will hopefully help those who struggle with staying focused and are looking to improve their habits. The system was designed with users in mind. By implementing a separate seat cushion, the feedback should be compatible with most existing desk chairs. The smart lock box should fit most smartphones and still be able to fit on the user's desk. The process of the research and design stages for this system are described in this document.

2.0 Project Description

This section is dedicated to the beginning of our design process. In the sections below, we will discuss the motivation and goals for our project, along with requirement specifications and constraints that our design should meet. Along with the main goals of our design, we have also included stretch goals that we would like to implement but may not be able to given some of our constraints.

2.1 Project Motivation and Goals

The problem of paying attention is one that everyone has experienced. From normal students faced with less exciting learning materials, to students with attention disorders struggling to focus on command, there is always room for a safety net for one's concentration. To solve the problems of students losing focus or being unable to pay attention, our team intends to create a device that alerts the student when their focus drifts, ultimately improving their performance with tasks.

In the age of smart devices and social media we also find ourselves distracted more often than not, phone in hand and unable to focus on anything but the latest message. An additional function of our device will be to seal our smart phones away during tasks we'd like to focus on, unsealing only when we've hit a certain amount of time spent focusing.

The overarching goal is to design a device that helps students pay attention, however, within that goal lies several smaller others . One initial goal is to identify software that can help us track whether or not a student is paying attention. Currently we are investigating eye tracking software for this purpose but generally investigating all software that may lend itself to this task is a goal for us. Another goal is determining the best kind of feedback to remind students to pay attention. Between both positive and negative feedback there are a multitude of options for us to choose from, such as including haptic or vibration feedback through a wearable device/ chair with the addition of positive reinforcement like a candy dispensing apparatus for when a student reaches a certain milestone in time spent focused. When we have identified the attention tracking software and feedback type we would like to use, there is an additional goal that arises in finding ways to connect the two; writing custom software so that the attention tracking device can talk to our feedback device as well as determining reliable

thresholds for when students should be given feedback. After our device is settled upon, further goals include optimizing cost so that the device can be accessible to individuals and students especially who have less money to spend. In addition to cost, optimizing the size of the device and attached software will also make it more available, so that is a goal of ours as well.

Our current goals are focused on identifying and testing software for eye tracking and achieving a software response from periods wherein the eye tracking detects no activity. Parallel to that effort are goals in developing an additional pressure sensing apparatus for the seat of the reinforcement chair to ensure that the user is seated in the device. Alongside both sensory devices is the research of our feedback options, one being a vibrating device attached to the chair that responds to bluetooth signals and the other being a device for the desk of the user that is able to restrain their phone.

2.2 Deliverables

Our final product will consist of various pieces of hardware as well as a website application. The app will provide users the ability to turn on and off the eye tracking features as well as customize how the hardware interacts with that eye tracking software. The hardware pieces will consist of modifications for a desk chair including a device on the back of the chair to provide vibration feedback and a sensor for the seat of the chair to make sure a student is in it. An additional system of hardware will be the smart lock for mobile phones that will sit on the desk of the student using this product. The smart lock system will most likely be wired while the chair mounted system will most likely be bluetooth connected, although wifi is being considered as an option as well.

2.3 Agile

For the organization of this project our team is aiming to use a pseudo-Agile method, which is to say that we will draw on techniques in the more traditional Agile-Scrum format but also have some of our own methods to balance our workloads.

One of the main features of Agile development that our team intends to draw from is the Sprint concept, or short work cycles to make regular progress forward. Our team typically meets 2-3 times per week, assigning work and evaluating progress on that work in each meeting. Rather than a single large goal we consistently break the project into smaller goals that we can achieve in these Sprint periods. One example of this is assigning certain sections of this document to research/ complete before the next meeting, as well as identifying minimum meeting-to-meeting milestones to be accomplished.

2.4 Requirement Specifications

This section will discuss the base specifications associated with the completion of our Concen-training system. Below is a brief table showcasing the specifications involved with the creation of this product, followed by a bullet-pointed list with a quick sentence describing each specification. Following that list is a series of sections going in-depth into the reasons as to why each specification was chosen. Table 1 shows a list of our desirable project specifications.

<u>Spec Number</u>	<u>Item</u>	<u>Specification</u>	<u>Acceptable Range</u>
1	Eye-Tracking Accuracy	>90% accuracy	+/- 5%
2	Eye-Tracking Registration Distance	1 meter	+/- 20 cm
3	Weight registration (chair)	~50 lbs	+/- 10 lbs
4	Weight registration (lock box item)	~0.3 lbs	+/- .1 lbs
5	Weight Limit	~200 lbs	+/- 20 lbs
6	Set-up Time	<10 minutes	+/- 2 minutes
7	Chair Module Size	<1 Square Foot	+/- 3 inches (length)
8	Bluetooth Connectivity	Within 3 meters	+/- 1 foot
9	Inactivity Threshold	~1 minute	+/- 30 seconds
10	Alerting Threshold	~30 seconds	+/- 30 seconds
11	Vibration Module Power	3.3-5 Volts	N/A
12	Communication Module Power	3.3-5 Volts	N/A
13	Vibration Module Battery Life	>=8 hours	+/- 30 minutes
14	Smart Lock Box Size	8" x 5" x 2"	+/- 2 inches in each dimension
15	Pressure Sensor Weight	>=90 lbs	+/- 10 lbs
16	Cable Length (Computer to Smart Lock)	~1 meter	+/- 30 cm

Table 1. Brief Requirement Specifications Table

1. The eye tracking software needs to be accurate in order to fulfill the function of the design.
2. Distance between the camera and user's face in which the eye-tracking software is able to register eye placement.
3. A threshold weight for the vibration chair module: It must be able to tell that a human person is sitting in the chair, rather than a decoy.
4. A threshold weight for the smart locking safe: It must be able to effectively alert the lock box that a distraction device has been placed inside of it.
5. A limit on weight for the chair attachment device: It must be able to effectively alert the user directly without the device being crushed.
6. Set-up time in terms of attaching the vibration device to the chair, wiring the apparatus to the computer/laptop, and starting up the focus software.
7. Maximum size able to be attached to the chair in question, whether it be on the back or cushion of the seat.
8. The connectivity distance maximum between the chair attachment device and alerting module.
9. Time it takes for the eye-tracking software to measure a period of inactivity/"lost focus".
10. Time after inactivity threshold where inactivity continues: after threshold, vibration module is alerted for focus stimulation.
11. Power required to run the vibration module.
12. Power required to run the communication module.
13. Lifespan of the battery for the chair vibration module.
14. Phone lock needs to support sizes of different phones.
15. Pressure sensors on the chair module should sense weights of at least 90 lbs.
16. Length for cable connecting the Smart Lock to the USB port of the laptop should allow the user to set it on their desk.

2.4.1 Eye-Tracking Specifications

One of the major functions of our Concen-training apparatus determining successful concentration training is through accurate eye tracking and registration. Therefore, we have set our target eye-tracking accuracy quite high, around 90% give or take. The more accurate we will be able to make this registration, the better our entire system will perform, and the less frustrated the user will be. Inaccuracies with this type of apparatus can lead to false flags to be raised, causing vibration stimulation without cause or even extending smart-lock durations, confusing and irritating the user.

Another aspect to take into consideration is the eye-tracking system's ability to register the user's eyes for participation in the concen-training program. Taking some off-handed measurements from our own computer screens to our eyes, the typical distance from a typical laptop is around 2 feet. However, to account for varied computer setups (i.e. people who have big monitors and can sit further away from their monitor), the goal

specification is for the eye tracking camera to be able to function from a distance of about 1 meter.

2.4.2 Weight Specifications

One major component of our vibration chair module and smart locking module are their weight sensors. In terms of the vibration chair module, a certain threshold of weight must be reached for the program to be initiated. Therefore, the program knows that a human-like body is sitting in the chair, ready to start studying/ testing, rather than a small stack of books to be used as a diversion. Thus, a value of around 50 lbs is to be used as the trigger weight with the assumption that people who would be needing this type of training software are at least that heavy. If this apparatus were to be adjusted for the purposes of aiding smaller children in improving their study habits, the threshold weight sensing can be adjusted.

In terms of the smartphone locking system, a much smaller weight sensor is to be used, due to the smaller scale of the typical distracting handheld device. The threshold for this pressure sensor was measured by weighing a variety of smartphone and electronic entertainment devices, with the lowest-weighing option being chosen as the threshold. The number to be used for proper sensing was determined to be about 0.3 lbs.

Besides weight sensing, the weight of the user must also be taken into consideration when determining the structural capacity of our vibration chair module. The seat must be able to withstand a certain amount of weight in order to function without the effects of compression or obliteration, which can ultimately prevent recurring use of the product as a whole. Given that the members on our team are all under 200 lbs in weight, we determined the structural integrity of the chair module will be considered a success if it can accurately be used with us without breaking. Constraints regarding weight will be discussed further in the constraints section of this document.

2.4.3 Safety Specifications

One of the primary concerns with this project is the involvement of electromagnetic components (i.e. the smart lock), which could in turn affect the health and safety of the user. Therefore, standards must be researched in order to identify any risk to the health and wellbeing of the participant with being in proximity to an electromagnet. Although the magnet intended to be used is quite small, the part still poses a safety concern, and must be thoroughly investigated. In addition to the health and well being of the user, the integrity of the smart devices being placed in the smartphone jail must also be upheld: we do not want our concentrating device to be responsible for the destruction of the property of the user. Standards related to electromagnetic interference will also be investigated further into this document.

Considering how the participant of this system will be in constant contact with one of our components (i.e. the vibration chair module), thermal concerns arise. It is important that the system have a flushed out ventilation system as to not heat the user's posterior beyond comfortable levels. Standards for ventilation will be discussed later in this document, as well as more information on battery packs in the case of battery heating.

Given that our concentraining apparatus relies heavily on the use of eye-tracking, there is a concern regarding the health and safety of the user's eyes. Whether our team explores the use of eye tracking lasers or any other setup, the safety of the user's eyes must be a top priority, since eye damage is considered a crucial injury by our team's standards.

2.4.4 Wireless Communication System Specifications

Wireless communications will be used to transfer data between the two computational modules. The signal to activate the vibration mechanism will be given via wireless communication, so an adequate response time is needed. These two modules should not be farther than two meters as one will be attached to the chair and the other will sit on the user's desk. Another factor to consider regarding wireless communication is power consumption. Different wireless communication options that vary in power consumption. Bluetooth low energy consumes less power than classic bluetooth, but may also come at a cost in regards to other features. Our wireless communication system needs to be power efficient, have a relatively high speed transfer rate and work within our required distance.

2.4.5 User Interface Specifications

The user interface needs to be clear, nice looking and easy to understand. In more specific terms the UI needs to have no spelling or grammar errors that would confuse users, additionally a consistent color scheme with the product in order to keep things easy to understand. If the eye tracking has a blue activity LED we can use a blue button to activate the eye tracking in the software UI. The UI should also have basic accessibility features such as alt text on images so that screen readers can properly describe the software to the visually impaired.

2.4.6: Accessibility Specifications

Accessibility is an important factor for our project design. There are many parts that the user should be able to easily have access to in order to replace parts. The vibration mechanism, the weight sensor, the secondary computational module and the power source will all be housed together on the user's chair. Our design should allow for a

simple way to open up the seat cushion we will create around these parts in order to gain access. That could be done by including a hinge and lock mechanism to open up the seat cushion or having easily removable panels inside the cushion.

The smart lock box will have less mechanical parts, but we will still focus on the accessibility of it. The main computational module will be fixed to the lock box, most likely on the back, so the user should have full access to that. The electromagnetic locking system will be embedded into the physical housing structure, so it will not be accessible but should not need to be replaced often, if at all. The same goes for the weight sensor in the lock box.

2.4.7 Hardware Specifications

The vibration mechanism and weight sensors will need to fit on the seat of a desk chair. The chair will also need a backrest to attach the secondary communication module. The chair will need to be sturdy enough to support the weight of these accessories along with the added weight of the human user. A strap will attach the vibration mechanism and weight sensor to the seat of the chair to ensure that it won't slide around. One strap will go around the sides and one will go around the front and back. Another strap will attach the secondary communication module to the chair either on the back or underneath the chair.

The smart lock box will need to be large enough to house a standard smartphone and also small enough to sit atop the user's desk. The locking mechanism will need to be secure so the user can't just take their phone out when it indicates it is locked, but also needs to be able to open quickly in case of emergencies.

The eye tracking software utilizes an external camera that will need to connect to the user's computer/laptop and be placed either above or below the screen.

2.5 Constraints

This section is intended to discuss limitations or restrictions that we might face when designing this product. The constraints will be broken down into sections regarding different aspects of the project such as hardware, software, time and economic constraints. In these sections, the issues we may face will be presented along with any possible solutions or ways to minimize the effect of these constraints throughout our design process and product presentation.

2.5.1 Hardware Constraints

One hardware constraint would be the ability to attain certain pieces of hardware in time to design our project. Products might be out of stock, the shipping might get delayed, or the price might be too far out of our budget. With many of the electrical hardware components that we will have in our design, another constraint is making sure our design is safe enough that the user will not have to worry about dangers like electrocution and flammable materials catching fire.

2.5.1.1 Weight Sensor Constraints

The weight sensor in the lock box needs to be able to identify if there is a phone inside the box for many different types of phones. All different styles of cell phones have different weights, so the lock box should be able to accommodate even the lightest cell phones on the market. As of 2020, the lightest cell phone available weighs approximately 3.11 ounces, so our weight sensor in the lock box should sense weights as low as 3 ounces.

Ideally, we would like the entire concentration module to be used by people of all ages, from students as young as kindergarten and first grade to as old as college and even beyond. Keeping this in mind, the weight sensor in the chair module should be able to sense a user who weighs as little as about 50 pounds to users who may weigh up to 300 or more pounds.

2.5.1.2 Vibration Mechanism Constraints

The vibration motor(s) in our chair module will play a significant role in the purpose of our design, as this will be how the user is alerted to when they have stopped focusing and need to return their attention to the screen. Knowing this purpose, the main constraints of the vibration motor(s) are size and power. The motor that we choose needs to create a strong enough vibration that the user will feel and be alerted by, while also being small enough to fit inside the chair module. Also, any cushioning that may be added on to the chair module for added comfort for the user should not dampen the strength of the vibrations so that the user will not feel them.

2.5.1.3 Computational Device Constraints

We will be using two separate computational devices to communicate from the chair to the lockbox and computer. One constraint here will be communicating wirelessly and making sure the two chosen devices are compatible. Another constraint will be choosing a device with the appropriate ports and abilities needed for our design. The size of the devices could also be a constraint depending on how they are being implemented.

2.5.2 Software Constraints

One constraint faced by our software engineers is a language constraint. Due to the limited number of available libraries for eye tracking software there is support for some but not all common programming languages. Additionally other applications of our product like an engaging user interface and conversing with and controlling hardware may require specific languages as well. The limits of those languages and how they interact with each other may constrain the speed of our hardware response as well as the speed and design of our user interface.

Another software constraint to consider is the operating systems of the end user. Our Tobii Eye Tracker 5 is stated to be compatible with Windows 10 but testing will need to be done to determine compatibility with MacOS as well as Linux and Unix operating systems. If the device itself is not compatible with other operating systems our product may be Windows exclusive in its first iteration and be unable to operate on MacOS or other operating systems until Tobii has supporting drivers to make that possible.

2.5.3 Safety Constraints

One safety constraint regarding the Smart Locking feature of our product is that mobile phones sometimes double as emergency devices. Our product will need to include a safety release feature so that mobile phones that need to be used as emergency devices are still easy to access for that purpose. The specific time it takes to access a device locked in our smart lock system will need to be less than 60 seconds in order to maintain an appropriate level of safety.

Another safety constraint is that we'll need to make sure our devices, both battery powered and wired, do not heat up to unsafe levels. A cooling mechanism may need to be installed to make sure users of the product are not burned in any way by the device they are using.

With motorized parts, safety is a main concern. The power source for the vibration motors will likely be on a separate part of the chair module. This is dependent on the chosen final design. If there are wires running on the chair the user is seated in, we must ensure they are not possibly exposed to any electric shock.

2.5.4 Presentation Constraints

If presentations are to be done in person the team will need to transport this product from our workstation to the presentation room. Since both a chair and computer are needed as well as possibly a desk to effectively demo the product, we will need to make sure all three of those are in our possession and that they can be transported to the

presentation room safely as well as that they fit within any doors that stand between our current location and the presentation location. At this moment the presentation location is not known to us and so the exact measurable specifics of these constraints are not set in stone.

Since transporting a PC with a tower and separate monitors would be somewhat unrealistic for our presentation, we will most likely opt to use a laptop for the task. This means we will need to make sure our team has a laptop with the correct specs to run our program in a demonstrable way. One of the minimum requirements for this is that we cannot bring a laptop with fewer than two USB ports as we are likely to need one for our eye tracker and one for our locking mechanism. Laptops with just one USB port can be supplemented with an additional USB bus but laptops without any USB ports would not allow us to present effectively.

The parts that we do need to transport will have to meet a certain level of stability in order to be transported safely. This means that the electronics will need to be stationed in a way that moving them or the device they're attached to does not rupture any wires or break any parts. The constraint here is that we cannot use parts that are too fragile and cannot lay parts out in a way that would restrict our ability to move them.

Additionally, due to worries about the power consumption of our devices, it would be most appropriate to present near a power outlet. Our team will need to verify that there is a power source at the presentation site. If there is not, the team will need to fully charge our laptop and associated product devices prior to the presentation and make sure that the length of the presentation is not more than the battery life of those devices can handle. If there is a power source the team will need to make sure our charging cables can reach the power source from where we will be presenting. If they cannot in their current constitution, extension cables will need to be obtained to present effectively.

2.5.5 Energy Constraint

With the design of our project, we will need to power multiple devices at once. The mechanisms on the chair include the computational device, vibration motors and weight sensors. These will require a fair amount of energy to operate, thus we might need to be close to an outlet for the power supply. We would like our system to be as energy efficient as possible, while still maintaining maximum function. Another energy constraint might be the different parts operating at different voltage levels. In regards to wireless communication, some forms consume less power than others (Classic Bluetooth vs Bluetooth Low Energy). We may need to consider different options for supplying power to different pieces of hardware.

2.5.6 Ethical Constraints

One ethical constraint that exists for this product is that of the privacy concern. As we will be working with the users camera we will need to make sure the users privacy is protected at all times by our product and that information that the user would prefer kept hidden is not inadvertently exposed by our product.

Another ethical constraint is with regards to the demographic of people attempting to use our training system. Some of the specifications of our experiment may not conform to all body types. For example, someone of a larger demeanor may not be able to sit comfortably or properly on the chair we implement with our vibration module, or, in an extreme case, the module may not have the structural integrity to withstand the weight of an exceptionally large person. On the other hand, if a small child were trying to use our project, their body weight may not be able to be registered, preventing them access to use the concentraining system effectively.

Besides body weight, the race of the person using the program could also be considered another demographic ethical constraint. Provided that eye tracking is the most vital part of our program, the size and shape of the eyes of the user can determine the effectiveness of the program. For example, someone with smaller, thinner eyes may have more difficulty with having their eyes tracked than someone with larger, wider eyes. Taking these racial and body weight factors into account, our team will focus primarily on making sure that our own personnel can be effectively registered, and further development on the project after graduation can be done to increase the accessibility of the project.

Another ethical constraint related towards the population using the program would be the health conditions each individual has which could affect the integrity or the outcome of the system. For example, people who tend to perspire more in the posterior could affect the operations of the vibration chair module, effectively shorting out the system entirely and causing damage to the operation of the entire concentraining apparatus. In addition to simple preparation tendencies, registration from the concentraining system may also become flawed if the user experiences many ticks and is physically unable to stare at the screen for extended periods of time. For these reasons, the concentraining apparatus will not be able to account for, and the data received will primarily be the result of experimentation done with our immediate groupmates, who are representative of the average college student demographic with no outstanding health or medical conditions.

2.5.7 Environmental Constraints

In Florida we are constrained by the somewhat extreme nature of the weather. Florida's intense heat can make it impossible to use parts for our electronic devices that would overheat too easily, as we may need to have the devices outside for extended periods of time as we transport them across campus. We Also need to make sure our devices have a way to avoid rain damage, as Florida's weather can often change quickly from sunny to thunderstorming and thus cannot use too many materials that would break down in high humidity.

Another environmental constraint has to do with light. The accuracy and reliability of the Eye Tracker device will go down in low light so making sure any rooms or environments that the product is used in are well lit is important. Some areas can be reliant on natural lighting which would make them difficult to use in Florida's heavy thunderstorms and at night.

2.5.8 Economic and Time Constraints

Since this project is for a class, we are on a strict time schedule. Senior Design 1 and 2 ends on April 27, 2021 and Senior Design 2 ends in early December 2021. Due to these time constraints, we have to limit our design to what is feasible in the allotted time. We won't actually start our physical design until Senior Design 2, which means we will only have one semester to complete the physical design, test it, and prepare our presentation. Our overall design needs to be achievable in this amount of time. Since we are a group of college students completing this project for our senior design class, we have to create a realistic budget. Our team has decided on a budget of \$600, however, we are willing to go above that if necessary to create the best product within all constraints.

2.6 House of Quality Analysis

The House of Quality is a visual tool used to incorporate design, manufacturing, sales and marketing of the product in question, and it contains matrices that relate aspects of the development process. Figure 1 shows the House of Quality created for this project, taking into consideration things such as Customer Requirements, Technical Requirements, Development Process and Requirement Weights.

Correlations are seen between two engineering design requirements, relationships are between engineering requirements and customer requirements, and "Direction of Improvement" is for determining our optimal level of performance for each specification. The requirement weighted sum takes the weight given to each customer requirement and multiplies it by its respective relationship, allowing the customer to see the

importance of each engineering requirement (the higher the score, the more vital it's functioning is).

By analyzing our House of Quality, we can see that the most important engineering requirements based on the customer requirements are the user interface, eye-tracking software and wireless capability. The least important requirements are weight, pressure sensing and the size of the lock box. Figure 1 shows our house of quality, and Figure 2 shows the key associated with reading the House of Quality.

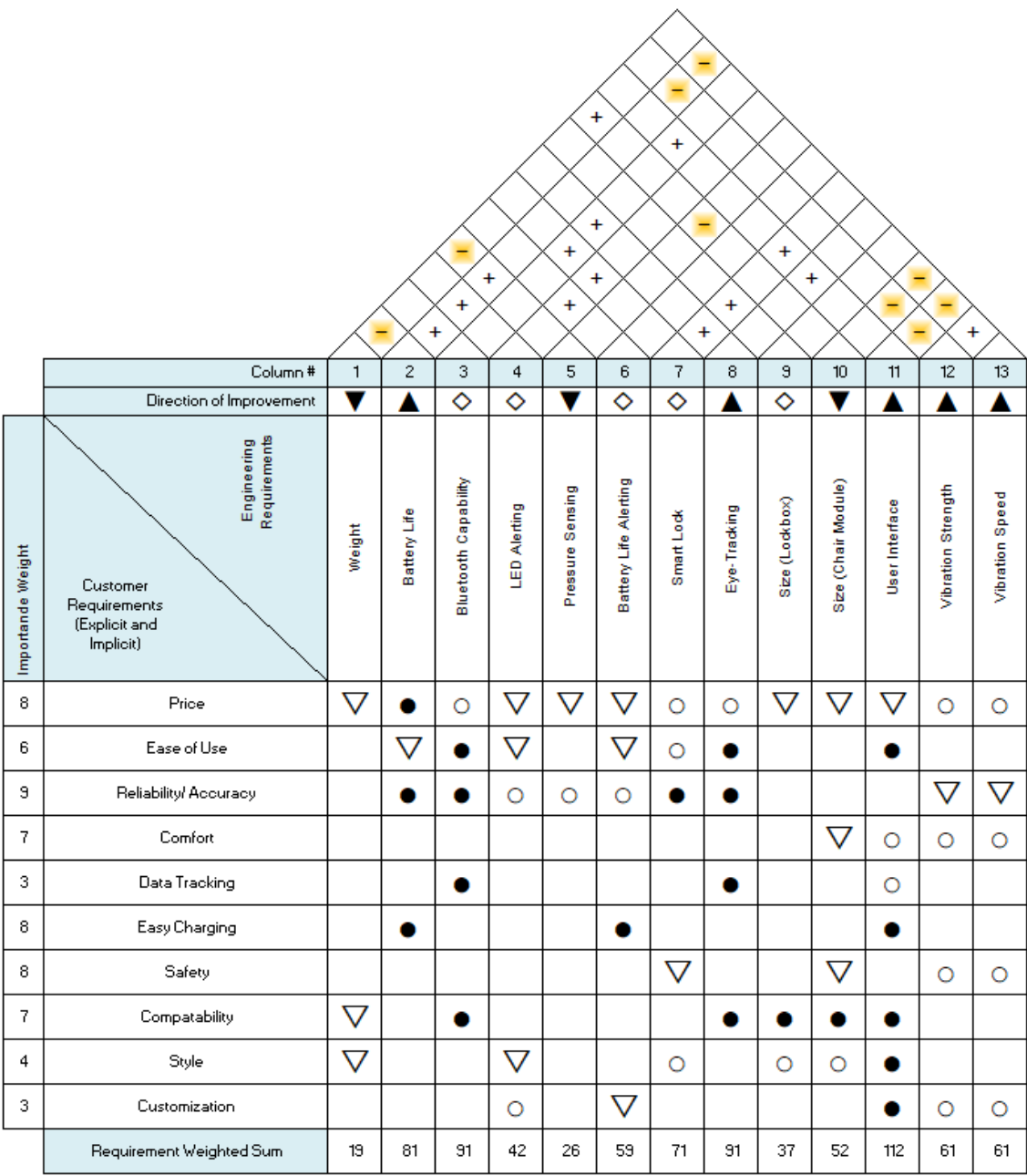

Figure 1. House of Quality

Correlations	Relationships	Direction of Improvement
Positive +	Strong (3) ●	Maximize ▲
Negative -	Moderate (2) ○	Target ◇
No Correlation	Weak (1) ▽	Minimize ▼

Figure 2. House of Quality Key

2.7 Decision Matrix

The decision matrix is similar to the House of Quality in the fact that it quantifies different aspects and gives a visual presentation by ranking the categories numerically. The decision matrix is different in the sense that it will compare our product to other existing products in the market to determine what factors make our design unique. Similar products are described in more detail in section 3.1.

The features that will be compared between different products include ease of use, customization, safety, reliability among others. These features can be easily compared between products since they are not device specific unlike eye-tracking, feedback and reinforcement. Our product will include all three of these features while the other products may only include one of them. Feedback refers to vibration or any physical feedback that is used to get the user's attention and Reinforcement refers to either negative or positive reinforcement used to help the user stay on track. Combining all three of these elements into one product is the key to making our product unique and effective. Table 2 shows our decision matrix, and Table 3 shows the key for reading our decision matrix.

Features	Level of Importance	Concen-Training	Revibe Connect	Pocket Points	Testing Environment (Honor Lock)
Cost	2	-1	-1	1	1
Ease of Use	3	1	1	1	1
Customization	3	1	0	-1	-1
Safety	3	0	0	0	0
Power Usage	2	-1	0	0	0
Install Time	2	-1	0	1	1
Reliability	3	1	1	0	1

Data Tracking	1	1	1	-1	0
Eye-Tracking	3	1	0	0	0
Feedback	3	1	1	0	0
Reinforcement	2	1	0	1	0
Total		12	8	5	7

Table 2. Decision Matrix

Level of Importance	1: Low	2: Medium	3: High
Feature Ranking	-1: Below Average	0: Average	1: Above Average

Table 3. Decision Matrix Key

As seen in the above table, our product outweighs the other comparable products based on features such as customization, eye-tracking and feedback. It is difficult to compare our product directly to others as ours combines elements from other products into one system. The Revibe Connect is a wearable device designed to help children maintain focus on the task at hand by vibration feedback. While this is similar to our design, ours can be customized to only vibrate when the focus is lost, not on an independent schedule. Both products are very expensive compared to the two other products, while the Revibe Connect is about one third of the cost of our design budget.

The Pocket Points app is a smart phone app that is designed to encourage students to stay off their phones during class. The student simply goes into the app to confirm that they are on campus and starts earning points by locking their phones. When they unlock their phones, they stop earning points. The points can then be exchanged for gift cards at a variety of restaurants and shops. This app uses positive reinforcement to encourage students to maintain their focus. However, it can only be used when physically on campus so it cannot be used when studying or taking virtual classes.

One of our stretch goals is to make slight adjustments to our product to be used in testing environments such as Honor Lock or ProctorHub. These testing environments require the students web cameras to be on and the student must show their student identification cards to ensure that it is them taking the exam. Honor Lock is a more strict environment as it requires a full 360 degree view of the students testing environment prior to the exam. The student is recorded during the entire exam and the video is saved in case it needs to be reviewed. These testing environments can also limit what the student can have open on their laptop/computer. A similar logic can be implemented

using eye-tracking. This product is different from ours in many ways, but the idea is similar, to make sure the student/user is not distracted and gives their full attention to the computer. The testing environment could be improved by combining our design by being able to see what the user is looking at and alert them when they've looked away from the screen too long, as this could be seen as cheating on an exam.

Overall, our product combines aspects of many other products available on the market today to enhance the user experience. By adding customizable settings for the feedback and reinforcement mechanisms, our product will be more user friendly than other options. The benefits far outweigh the slightly longer installation time and power usage.

2.8 Project Measurables

The goal of our product is to help the user improve their focus and be more productive with their time. By keeping them free of distractions (their phones) and alerting them when they have lost focus (vibration alert), the user will be able to have a more effective work environment.

In terms of project measurables, one thing we can measure is the response time between the eye tracking system and the vibration alert. If the vibration alert takes too long, the system will not be as efficient as possible. We want the overall experience to be prompt and maximize the productivity of the user. Another response time we can measure is how long it takes for the lock box to open after the emergency release is pressed. In the case of an emergency, this feature needs to be quick enough that the user can call for help. The weight sensor will need to be accurate to make sure there is a person sitting in the chair and a phone is in the lock box.

Some elements that are important to our project such as cost, ease of use and installation/setup time can also be looked at as measurables. Although our budget for this project, an initial prototype, the future cost of manufacturing the device for consumers could be scaled back in the future. We want the customer to have the best experience and truly get their money's worth and we believe our product will be worth the price. The installation time should be minimal, however, there are a few separate parts to set up. The lock box will have to be set up on the user's desk or within a certain range from their computer as the main computational module will need to be connected to the user's computer via a cable. The eye tracking may require a camera which will sit either below or above the user's computer. The seat cushion that includes the vibration and weight sensors for the chair module should be simple to add onto any desk chair.

2.9 Stretch Goals

Given the time and resources, we would implement additional features to our base design. The first addition would be to add a “stretch break” feature. Once the user has been sitting for an extended amount of time, they will be prompted to take a quick, few minute stretch break before returning to their desk.

Our design could be modified to be tailored towards online learning and test taking. If a student is taking an exam, the eye-tracking software would be helpful to determine if the student is looking at other notes or resources, and if their smartphone is locked away in the lockbox during the extent of the exam or quiz. Another modification would be similar to existing testing softwares that only allows specific windows to be displayed on the screen during an examination.

Another goal could be to determine what is on the user’s screen and detect if the person is looking at their study material or playing a video game. In our current design, there is no way to tell if the user is actually using the device to study or work which is the intended purpose. If the software would determine the coordinates of the user’s gaze, and what is displayed on that part of the screen, the product could be tailored to eliminate unproductive content.

Along with the current design’s vibration mechanism to regain the user’s focus, we could add an indicator that pops up on the user’s laptop/computer, along with a noise to regain their attention. We could also add a form of positive reinforcement for maintaining uninterrupted focus for a certain amount of time. Possible positive reinforcement could include candy/treat, a short fun video or game.

Data tracking is another stretch goal for the concentraining apparatus. If time were to be permitted, a data tracking software element would be implemented, allowing for the user to review “concentration streaks” or “concentration trends”, giving them the option to view their focus growth over extended periods of time, such as over a month, multiple months or even years. This implementation would work as an additional positive reinforcement mechanism, encouraging users to participate more, keep up their “streaks”, or even compete with their friends to see who can be the most focused out of anybody.

Stemming from the idea of viewing your focus streaks, the implementation of an extensive mobile application is another long-term goal that we may not be able to implement within the time provided. Not only would the application have the ability to view your concentraining streaks, but it would also have the ability to provide further deterrents, encouraging the disuse of the smart device in question. For example, much

like pocketpoints (discussed in section 3.1), virtual points could be awarded for extended periods of time without your phone, and extra points could be awarded for skipping smart phone breaks and leaving your device in the smart lock box. This mobile app could also forcefully lock the entire device digitally until a break is rewarded, acting more as a deterrent and less like an optional choice (this option could be more suited for professional environments).

Extensive customization is also another idea to explore, and one example could be in regards to the ability to customize vibration speed and strength of the chair module. Much like how some smartphones are able to change ringtones to better suit the ears and alertness of the user, being able to easily customize the vibration speed and patterns of the chair module could be beneficial in terms of making the apparatus as a whole more appealing to the average customer. Although it can be reprogrammed by reworking code, a simple button on a mobile or web application could make it easier to set specific vibration patterns for things such as a quick nudge to get back to work, a reminder to take a break and walk around, or even a notification for when the battery of the chair module is running low.

Referring back to the chair module, posture sensing is another great way to improve the health and well-being of the user. By adding additional sensors to the back of the chair (or any other location along the chair, possibly including the arms), the posture of the user can be tracked. Since posture can also affect the performance of the user, implementing this extra sensing system could further aid in the development of good focusing habits, as well as better overall health of the user.

Lastly, a vital stretch goal which we would like to implement into our ecosystem is a State of Charge Estimator. Because the original design of our system includes a rechargeable battery, a simple state of charge estimation system would allow the user to know when the seat must be recharged. Because we wish for the chair module to be sleek in design, it should not be powered directly by a wall outlet, and must be recharged at some point after each use, and since our long-term goal is for it to be usable for the duration of an 8 hour workday, this estimator would make it easier for the user to identify when it needs to be charged back up again.

3.0 Research and Investigation

This section is dedicated to researching prospective parts for our project design. We also address similar products already in the market and how ours will differentiate from previous designs. Pros and cons of different parts will be weighed to determine which

ones will best fit our design needs. Different possible methods will also be investigated for implementing functions such as weight sensing and wireless communication.

3.1 Existing Similar Projects and Products in the Market

Currently there is a device called Revibe Connect that is wearable and uses vibration feedback for students. This device however is based on a fixed timer and will alert students whether or not they are currently paying attention; in fact it may even become a distraction to a focused student. By pairing our device to eye tracking software, we may be able to create a more customized experience for each student as well as one optimized for online learning.

There is also an app called Pocket Points that rewards students for not using their phones in class with points they could redeem for coupons at local vendors. This is the most similar device in function and purpose to the smart lock application of our device that seals away the user's phone for a predetermined period of time for them to study. Based on experience using the app, it is a very loose barrier between the user and the device, and easily dismissed. While our device would still have a release button for emergencies, it would be slightly harder to become distracted by the device and that added difficulty would hopefully cause fewer distractions. In current times the Pocket Points system that requires students to be on campus to take advantage of their services is in a way outdated. Our product would be usable from the user's own house where most of their learning takes place these days and where most studying takes place in general.

In relation to the smart locking system, two similar products were found on the market. The first of which is called the SONOFF smart locking system, which was found to be a cheap smart door locking apparatus from youtube. The system consists of either a strike plate lock or a surface mount magnetic lock and a SONOFF SV, which is a piece of smart hardware connected to a mobile application for usage, a computer and an USB adapter. Controlled via the mobile application or an external switch. Studying the hardware within this system will give insight into how a smart locking system is achieved, as well as the types of locks that could be utilized. The general description for a locking apparatus is discussed later in this paper in section 3.8, which helps to identify key components of the smart lock safe.

One system actually implemented in this class for testing is Honor Lock, and our stretch goals kind of relate to an improved functioning of its purpose. Honor Lock is an online proctoring service, aimed at hindering cheating and prioritizing academic integrity. It utilizes the camera and accesses the user's network to check if either you are looking at a device or checking it off camera. It is a very smart testing system. Related to some of our stretch goals or alternative uses, the concentraining apparatus could be used as another type of testing software with the addition of a reinforcement system (vibration module, smart phone lock). The software would be beneficial to look at in terms of

gaining insight into how the eye tracking system works with webcams so we can implement that into our own software design.

Through investigation, it was discovered that simple electromagnetic lock designs are used frequently for the purpose of “escape room” puzzles. These locking systems can hold secrets to unlocking the next puzzle and are either activated by a mechanical switch or a digital signal (via a button being pressed remotely). Observing these remote-activated locking systems can give insight into designing integrated smart locking systems where the locking mechanism would be controlled by a coded signal from the eye-tracking camera.

Power charging banks typically have a multi-LED notification system, showing a general estimation of the current charge level of the device. Studying how this system functions would be beneficial in designing a simple state of charge notification system, allowing our design to reach one of our stretch goals. In addition to power banks, other smart devices are able to project their charge estimation onto other devices (for example, some pairs of wireless headphones are connected to their phone via an app, where their charge levels can be determined). If time constraints allowed, the state of charge estimator would be perched on the smart lock box for easy visibility.

In the design of the chair module, we intend to utilize a weight sensor to determine when the user is actually seated in the chair and ready to begin their study session. A product available to consumers by National Call Systems serves a similar purpose to determining if a person is currently sitting in a chair based on the weight being applied to it. This system is used mainly in nursing homes or other senior care facilities for people who may be in a wheelchair or have difficulty moving on their own to help prevent them from falling or wandering. When the weight is relieved from this sensor, it sends a signal to a fall monitor which then alerts a caregiver that the person in the seat or wheelchair may have fallen over.

3.2 Computational Devices

A computational device will be connected directly to the user’s laptop to process the data from the eye tracking software and determine when to send signals to the chair and lock box. To determine which device will be best for our project, we need to consider some important factors such as hardware and software requirements, architecture, bit size, memory, cost, power and battery requirements.

In our case, the computational device will be connected via USB to the user’s computer. This is how information will be transferred between the two devices. Depending on the design, the lock box will either be directly connected, hardwired, to the device or will communicate via wireless connection. The device will also wirelessly communicate to the hardware in the chair. Therefore, it will need wireless capabilities or the option to

add on a wireless communication module. The software will need to be updated quickly to minimize the delay between signals sent to the chair or lock box.

3.2.1 Single Board Computers

Single Board Computers (SBCs) offer the processing power of a full sized computer in a small circuit board. SBCs use a System-on-Chip (SoC) in order to integrate mostl, if not all, components of an electric system. This system is very advanced and offers an array of features such as signal processing, wireless communication and artificial intelligence. Single Board Computers are very similar to microcontrollers in the sense that they are both small circuit boards that are used to accomplish computational tasks.

3.2.2 Microcontroller Units

Microcontrollers (MCUs) are small, integrated circuit boards typically designed to perform a single task and control other portions of a system. There are two common architectures for microcontrollers, Von Nuemann and Harvard. Von Nuemann uses the same memory to store instruction and data. With this architecture, data transfer and instruction fetching cannot be done at the same time. However, Harvard architecture uses separate buses to transmit data and fetch instructions. This design allows for the separation of memory access and ALU operations, which requires less computational power, resulting in reduced cost and low power consumption. Another advantage of this is the heat dissipation which makes these types of MCUs ideal for battery powered devices.

The bit size of the microcontroller is important to ensure that it can handle all the data being passed through it. There needs to be adequate memory for our project. Since we need to communicate between the chair and main module, we will need two MCUs. One will be in the chair to control the vibration motors and get information from the pressure sensor, and the other in the main communication module to communicate directly with the computer and lock box. The two microcontrollers will need to communicate via bluetooth. The one in the chair will only be used for simple tasks such as turning the vibration module on or off and sending the input from the pressure sensor to the main module.

For our project, we will need two separate computational devices for different purposes. The first one will be used as the main communication module. For this device we will need most likely a SPI port to communicate with the user's computer, a port to communicate with the smart lock box, a form of wireless communication to the other device on the chair, and a few connections for LED lights.

From previous courses, we have already purchased some microcontrollers that could work within the parameters of this project. These, along with other options, will be discussed in the following sections.

3.2.3 Texas Instruments MSP430

The MSP430 family of MCUs produced by Texas Instruments are 16-bit microcontrollers that offer affordable and cost efficiency options. Below are two MCUs from this family that our group currently already owns.

3.2.3.1 MSP430G2553

This 16-bit, ultra-low-power MCU has 16KB of flash, 512B of RAM and up to 16MHz CPU speed. It has a supply voltage range of 1.8 V to 3.6 V. It has 24 GPIO pins, two 16-bit timers, one USCI supports UART, IrDA and SPI and one USCI supports SPI and I2C. This MCU also has a 10-bit analog-to-digital converter which would be ideal for reading information from the weight sensors and converting this information to digital to be processed.

3.2.3.2 MSP430FR6989

This 16-bit, ultra-low-power MCU has a 16MHz clock. It features an LCD display, two buttons and two LED lights. It has a supply voltage range of 1.8 V to 3.6 V. The MSP430FR6989 has 128KB of FRAM and 2KB of SRAM. It has two USCI channels that support UART, IrDA, and SPI, and another two USCI channels that support I2C and SPI. This MCU has a 12-bit analog-to-digital converter. To program this MCU, TI recommends using an IDE such as their Code Composer Studio or IAR Embedded Workbench. The code can be written in C/C++. TI offers a wide range of BoosterPack modules that can be connected to this MCU allowing for wireless connectivity, graphical displays and more. It also includes onboard emulation and debugging, and connects to a computer via provided USB cable.

3.2.4 nRF52840

Nordic Semiconductors' nRF52840 is equipped with Bluetooth 5 at 2Mbps and is built around a 32-bit ARM Cortex_M4F processor at 64MHz. It has a supply voltage range of 1.7 V to 5.5 V. It has 1 MB of flash memory and 256KB of RAM. The nRF52840 has 48 GPIO pins and supports SPI (3), 2-wire, I2C and UARTE (2). The recommended language for the nRF52840 is C as there is provided support for this language.

3.2.5 Raspberry Pi

The Raspberry Pi is a very powerful single board computer. They are affordable and easily accessible to everyone. This line of computational devices is commonly used to

introduce eager, young students to programming and electronics. All models have a thermal management system in place to help prevent overheating.

3.2.5.1 Raspberry Pi Zero

This small, low cost single board computer uses the BCM2835 Broadcom processor model which is equipped with a 1GHz single core CPU and 512MB of RAM. It has 54 GPIO pins and is powered by a micro USB port. It has one mini UART, two SPI masters and I2C. This device has a mini HDMI port, a micro USB OTG port, and a CSI camera connector. There is also a version of this device, the Raspberry Pi Zero W, which is enabled with wireless LAN and Bluetooth (4.1 and LE) capabilities in addition to the specifications previously mentioned. The recommended programming language for the Raspberry Pi Zero [W] is Python or C/C++, with Python being the more common option.

3.2.5.2 Raspberry Pi 4B

This tiny device can take the place of your desktop computer. It uses the BCM2711 processor which is an upgraded version of the quad-core CPU design used in the BCM2837, now using the ARM A72 core. The Raspberry Pi 4B 64-bit ARM core runs at 1.5 GHz. The BCM2711 chip also has an improved heat spreading technology to help aid with better thermal management while still providing the same level of performance. This system is powered by USB-C (3 V - 5 V) or by GPIO header (3 V - 5 V) and has one mini UART, two SPI masters and I2C. This device has 58 GPIO pins. The Raspberry Pi 4B is equipped with dual-band 2.4/5.0 GHz wireless LAN and Bluetooth 5.0 (BLE). The most commonly used language for programming Raspberry Pi products is Python.

3.2.5.3 Raspberry Pi Pico

The Raspberry Pi Pico is a tiny, fast, microcontroller board that uses the new RP2040 MCU. The RP2040 features a dual ARM Cortex-M0+ at 133 MHz and 264 KB SRAM. The Raspberry Pi Pico is equipped with two UART, two SPI, two I2C and three 12-bit Analog-to-Digital Converters (ADC). It has 23 GPIO pins and a supply voltage range of 1.8 V to 5.5 V. Raspberry Pi offers support for programming this MCU with C/C++ and MicroPython.

3.2.6 Comparison

Below is a chart comparing all the computational devices discussed in previous sections. By breaking it down into categories such as price, supported languages and communication abilities, we will be able to make the appropriate decision on which devices will best suit our overall design needs. Figure 3 shows a table of comparisons between each microcontroller investigated.

		Computational Device					
		MSP430G2553	MSP430FR6989	nRF52840	RP Zero [W]	RP 4B	RP Pico
Features	Price	\$13.29 (free)	\$24.00 (free)	\$12.95	\$10.00	\$35.00	\$4.00
	Memory Size	512B	128KB	256KB	512MB	2/4/8GB	264KB
	GPIO	24	83	48	54	58	23
	Operating Voltage	1.8 V - 3.6 V	1.8 V - 3.3 V	1.7 V - 5.5 V	3.3 V - 5 V	3 V - 5 V	1.8 V - 5.5 V
	Clock Speed	16 MHz	16 MHz	64 MHz	1 GHz	1.5 GHz	133 MHz
	Bit Depth	16 bit	16 bit	32 bit	32 bit	64 bit	32 bit
	Supported Languages	C/C++	C/C++	C	Python/C++	Python	C/C++/ MicroPython
	Communication	UART, IrDA, SPI (2), I2C	UART (2), I2C (2) SPI (4)	UARTE (2), SPI (3), I2C, BLE 5.0	mini HDMI, mini UART, SPI (2), I2C, [BLE 4.1, WLAN]	mini UART, SPI (2), I2C, BLE 5.0, 2.4/5.0 GHz WLAN,	UART (2), SPI (2), I2C (2)

Figure 3. Computational Device Comparison Chart

3.2.7 Computational Device Conclusion

After comparing all of the above choices for computational devices, the following selections have been made. The decision was based on features such as price, supported programming languages, number of GPIO pins and communication options.

3.2.7.1 Main Communication Module

The main communication module will be the device directly connected to the user's laptop/computer and the smart lock box. This device will do the majority of calculations and processing. This module will communicate wirelessly to the secondary module. For these operations, the best device option will be the MSP430FR6989.

3.2.7.2 Secondary Module

The secondary module will be housed in/on the chair to control the vibration mechanism and the weight sensor. This device will mainly be used for simple tasks such as turning the vibration motors on/off and reading in the weight sensor data. This module will communicate wirelessly to the main module. For these operations, the best device option will be the MSP430G2553.

3.2.8 Lockbox Electromagnet Microcontroller Option

As previously discussed in the "similar products" section of this paper, the SONOFF microcontroller is a device used for smart integrated device home projects. According to their website (which features many smart products), these devices can be used for a

multitude of open source projects, such as a wifi controlled extension cord, smart house appliance apparatus, or even a smart electromagnetic locking system. The controller that is able to function with the Electromagnetic lock previously mentioned is the SONOFF SV DC module. It provides users with a cheap, low power option to make home appliances smart. With a little bit of welding, this device can connect to a wide variety of appliances. If able to work with pre-existing products, this device could be a good contender when reflecting on smart locking brain devices. Figure 4 shows an image of this SONOFF SV microcontroller device.



Figure 4. SONOFF SV microcontroller board (permission pending)

Using this product would allow easy integration of the electromagnet into our system. Already coming with designated pins for a 12V electromagnet to be soldered on, this would be a quick and easy solution for a smart lock.

One downfall to using this device comes with the fact that the SONOFF software must be used in order to use the switch, which may take some time to learn or reprogram. However, there are available tutorials online if this would be the desired result for the product. This low voltage switch also utilizes an ESP8266 microprocessor.

3.3 Sensors

For our project, two types of sensors will be utilized. Weight sensors will be used in the chair to determine if there is a person there. They will also be used in the smart lock box to determine if the user's phone is inside. A camera sensor will be used to track the user's eyes to determine if they are looking at their computer screen or not. Different options of each will be discussed and compared below.

3.3.1 Weight Sensor

Weight sensors will be used for multiple purposes in this project. There will be at least one weight sensor on the seat of the chair to determine if someone is sitting in the chair. An additional sensor could be added to the backrest of the chair to determine if the user is sitting with good posture. This could be more challenging since pressure being applied on just one part of the backrest and on the seat doesn't necessarily indicate good posture. The user would have to have some control over how effective they want the software to be for them. The weight sensor in the chair could also be helpful for knowing how long the user has been sitting and when it might be time for a stretch break.

A weight sensor will also be used inside the lock box to determine if there is a phone or other smart device in the lock box. This will allow the locking mechanism to determine when to lock once the device is placed inside, and can remain unlocked when there is no device inside. Without a weight sensor inside the lock box, there would be no way to know if the user actually put their device in the box.

3.3.1.1 Chair Weight Sensor

The weight sensor on the chair module is going to be more complex than the one in the phone lock box. This sensor will need to recognize above a specified weight rather than just recognizing whether or not there is an object on it. Also, since the user will be sitting on this sensor, it will need to withstand the weight of a person on it without suffering major failures. This weight sensor is meant to tell when a person is in the seat, so it needs to be more complex than just whether or not any amount of weight is being applied. In this section, different options for weight sensors will be researched and compared to find the best option.

3.3.1.1.1 Velostat Weight Sensor

To design a sensor that can withstand the weight of a person sitting on it as well as sense this amount of pressure, one viable option would be to use Velostat. Velostat is a carbon-infused conductive plastic material that changes resistivity depending on the amount of pressure applied to it. Using velostat with other conductive materials, such as copper tape, we can create a circuit and measure the change in the resistance of the velostat when pressure is applied to it. The main benefit of using a sensor with velostat is its cheap cost as well as the ability to create a sensor that specifically fits the size of the chair module. The downside to using this is the variability in the resistivity of the velostat. There are no predetermined specifications for velostat, which means we would have to make measurements on the velostat before building the sensor to know what resistance we get with certain pressure applied.

3.3.1.1.2 FlexiForce Sensors

FlexiForce sensors are piezoresistive weight sensors that are available in a variety of ranges for the amount of weight allowed where the sensor will work. Similar to the velostat, the piezoresistive properties of the sensor mean that as the amount of pressure applied to the sensor increases, the resistance in the sensor decreases. These sensors are very thin which would make them easy to integrate into a seat cushion, and they can also support up to very high weights. The combination of these specifications would make this type of sensor an ideal choice for our chair sensor. One of the main limitations of this sensor is the size of the sensing area. We would need to implement something into our design that would take the full force from the person dispersed across the seat so that it can be measured on the small sensing area.

3.3.1.1.3 Strain Gauge Load Cells

Strain gauge load cells are another type of commercially available weight sensor. Strain gauge load cells are commonly used in bathroom scales, which should make it very useful for determining whether or not a person is sitting on the chair. The strain gauge changes its resistance in response to the amount of weight applied to the system. Whether it is a compression force or a tension force, it will react in different ways. The load cell is set up in the form of a Wheatstone bridge circuit. Instead of four resistors being used to create this circuit, four strain gauges are used. When the circuit is supplied with a constant input voltage, the output voltage will change depending on the resistance of each of the four strain gauges. In our design, we could supply a voltage to the strain gauge load cell and measure the output voltage at varying levels of force to determine when the sensor should activate the rest of the system. One potential drawback on choosing a strain gauge load cell for our design is the durability and longevity of the strain gauge. The differential in the resistance of the strain gauges when pressure is applied is necessary to make sure we have an accurate output voltage reading. If the strain gauges become overloaded and are not able to revert back to their original shape when the force is relieved, our readings will become inaccurate.

3.3.1.2 Phone Lock Box Weight Sensor

The phone lock box weight sensor has the sole purpose of determining whether or not a cell phone is placed in the box. The amount of weight that this sensor is able to support is not an issue, meaning there is a wide variety of options that can be implemented into the lock box.

3.3.1.2.1 Homemade Weight Sensor

Since the sensor in the lock box has the sole purpose of determining whether or not a phone is placed in the box, a very simple homemade weight sensor could be built and implemented. One option of a homemade weight sensor would be to make a velostat

weight sensor and use the resistance created by the weight being applied to the sensor to know when the phone is locked away. Similar to the velostat, a simple sensor could be created with items as simple as aluminum foil and cardboard. Aluminum foil, or some other conductive material, would be attached to one side of two pieces of cardboard, or some other material with an ability to slightly flex under pressure. By keeping the two conductive materials separated from one another when no pressure is applied, a circuit would be created when the two sides touch after having the pressure applied. Wires attached to the conductive surfaces would be used to apply current that will only be read through the other wire when the two conductive surfaces are connected. The benefit of using one of these homemade sensor designs is the low cost and ability to integrate into our design. Despite the benefits, using a homemade method for this sensor causes potential for error, as it is not professionally designed and does not have set specifications.

3.3.1.2.2 Commercial Weight Sensors

Commercial weight sensors are the alternative option to using a homemade weight sensor. Commercial sensors, such as the FlexiForce sensors mentioned earlier, offer the benefit of having set specifications that we could utilize to our advantage in our design. By knowing the approximate weight of popular smartphones, we would be able to test the sensor and measure what it would read when a phone is placed on the sensor. We would then be able to use the measured reading to allow the lockbox to know when there is a phone placed inside so that the locking mechanism can be activated.

A drawback to using the FlexiForce sensor is the small area of the sensor that actually senses the weight being put on it. We would need to make sure that the cell phone is placed directly on this area of the sensor or else we would not get an accurate reading. This would limit our options when it comes to designing the lock box as we would need to make sure that the user's phone would be on the sensor at all times while the phone is inside the box.

3.3.2 Camera Sensor

For the eye tracking system, there are two different methods being considered: one is gaze tracking using a typical webcam most users would already own, while the other is eye tracking using infrared sensors that is typically more accurate.

Further testing will be done comparing the accuracy of webcam based eye tracking before a final decision can be made regarding webcam gaze tracking and infrared eye tracking.

For Gaze Tracking applications there are two standout pieces of software being considered. One is called GazeRecorder and the other is called WebGazer.js. Both GazeRecorder and WebGazer.js are free to use and in theory allow for the use of any common web camera. Each has a unique calibration mechanism and ways to demo the technology. The team will be testing both to determine which appears more reliable.

GazeRecorder uses a javascript API that can be embedded in any website. The FAQ on GazeRecorder's website lists a working distance of 40-95cm or between 1.33 feet and just over 3 feet. This is a fairly realistic distance for how far away from the camera most people sit when using a laptop or computer. GazeRecorder requires a 2 minute calibration for use, and does not list webcam specifications, claiming to work with most webcams. Further testing will need to be done to determine upper and lower bounds for resolution in normal lighting. GazeRecorder also claims to work for users who wear glasses and contacts, and it has worked for me wearing glasses, however some glasses that obscure the eyes could make it hard to work and those constraints will need to be accounted for.

GazeRecorder once calibrated does allow users to look away from the screen, finding the users eyes again fairly reliably as they look back. Our product will be taking advantage of periods where the software does not sense the users eyes to take action. Currently GazeRecorder lists 5 browsers as supported on their platform, taking the javascript and applying it to a webapp should remove limitations associated with browsers.

GazeRecorder has its own associated desktop app that is used for gathering data from the eye tracking, the app can be used to start and stop recording the gaze settings and calibrate the gaze. These functionalities will form a good basis when it comes to integrating with our UI, allowing us to not have to redesign as many of the eye tracking controls and focus instead on adding more options for the user.

For Infrared applications, typically the user of the product will need to be wearing a pair of glasses or goggles with an infrared sensor pointed at one of their eyes, this adds a larger mechanical task to the project and would make it a bit harder for people to use.

The model for an infrared goggle and associated software would be based on the work by John Evans as part of a 2018 Hackaday contest submission. Evans designed an open source eye tracker that can work with cheap (\$20) webcams and his own "Jevons Camera Viewer" app that coordinates the infrared camera feedback from the goggles he designed with webcam feedback to get more detailed eye tracking data. John Evans' wearable device is shown below in Figure 5. Because of the placement of an infrared

camera on one of the lenses of the glasses, it is likely that these glasses also obscure vision at least partially for one eye. This cost in terms of field of vision is a reason our team would prefer not to use such a device.



Figure 5. John Evans wearing his infrared eye tracking goggles

Another guide on infrared eye tracking is a paper called 'Do-It-Yourself Eye Tracker: Low-Cost Pupil-Based Eye Tracker for Computer Graphics Applications' by 4 researchers in Poland. This guide offers similar methodologies to the approach used by John Evans while also contributing unique software and design applications for a 30 euro cost evaluation. Their design is similar to what is pictured below in Figure 6 and also has an element of obscured vision. For their part their design is slightly more sleek and has fewer camera elements on the goggles themselves than the John Evans' approach. [7]

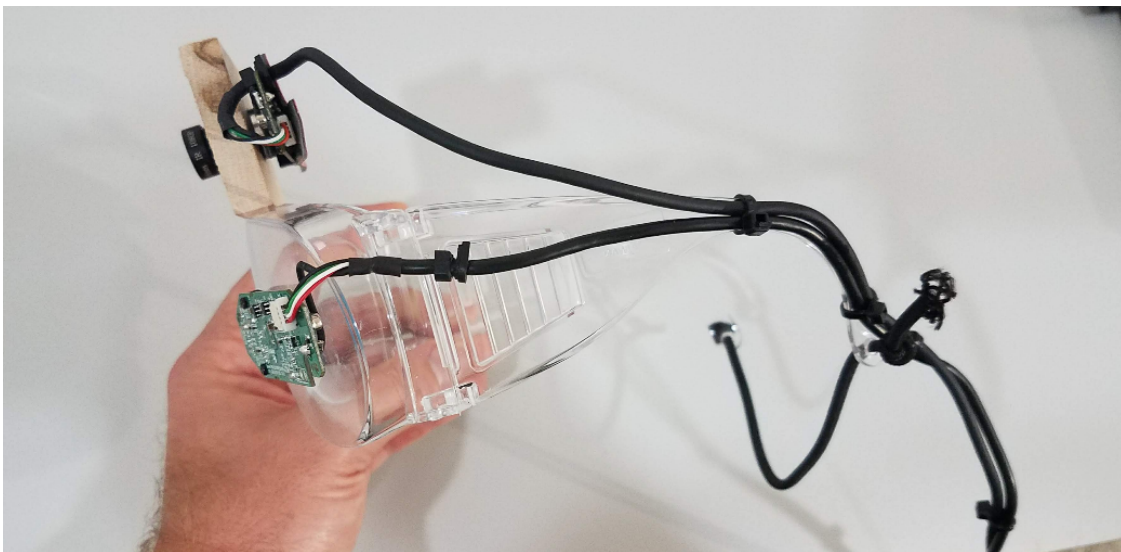

Figure 6. The infrared eye tracking goggles as designed by John Evans, side view

If a wearable infrared sensor is deemed necessary for this product, both the work of John Evans and these researchers, Mantiuk, Kowalik, Nowosielski and Bazyluk, will be used to design a wearable sensor that is affordable and keeps the reduced vision aspects to a minimum.

Another model for the infrared option is using the software and hardware of the TobiiPro company. This company develops eye tracking devices for research as well as for entertainment. Their research tools cost thousands of dollars and are well beyond the scope of this project but their entertainment device is roughly \$200 and may be an option to consider. However the entertainment device, seen in figure 7, passes a lot less data to the user for our program to then use for decision making.



Figure 7. Tobii Eye Tracker 5

The tobii Eye Tracker 5 as shown in Figures 7 and 8 is roughly \$229 and does not require the user to wear any glasses or device to achieve infrared detection. It has associated software to show the user where their eyes are looking on the screen but further associated software is unclear. This eye tracker is the strongest of the potential methods, as it is more robust against low light environments and not cumbersome for the user. The price however is a significant drawback and it is unclear how much support would come with the Eye Tracker 5 for writing associated software. [8]



Figure 8. The Tobii Eye Tracker 5 attaches to the monitor at the bottom

One associated software that can be used with the tool is the Tobii Concept Validation Tool which is sample software for a few tasks that allow you to interact with your pc using just your eyes. This software may provide a basis for us to write further software if we choose a tobii Eye tracker. One specific part of the Tobii Concept Validation Tool was a process that played a video when the user was looking at it, and stopped the video when the user looked away. This kind of functionality is very similar to what our product will be doing in terms of reacting to distractions, and such will be pursued as a potential basis for us to work from.

Tobii also has sample code in their Tobii Interaction Library SDK to allow users to interface with the Tobii Eye Tracker Device. This is available in a few languages including C, C# and C++. For the sake of our project we will be using C. The sample code has instructions on writing text to the terminal in response to eye movement. Our team will need to develop further code on top of this in order to communicate and get corresponding actions from our associated bluetooth devices.

3.4 Communication Module

Our project will utilize wireless and wired communication to transfer data between devices. Wireless communication is necessary for the two computational modules to send information to each other. Two forms of wireless communication will be discussed below along with how we intend to implement the desired method. Wired communication will also be discussed below along with the benefits of each method.

3.4.1 Wireless Communication

WiFi is used to connect devices to the internet as well as other devices. This is ideal for sending large chunks of data across longer distances. On the other hand, bluetooth is used to connect devices within a close range together without requiring internet access. Bluetooth uses weaker signals and uses spread-spectrum frequency hopping to switch between channels to avoid interference better than WiFi. Bluetooth devices also consume less power and are usually cheaper. However, WiFi is known to be a more secure way to transfer data.

The selected wireless communication will be used to connect the main communication module, the Smart Lock Box, and the vibration mechanism and sensors on the chair. The main communication module will be hardwired to the user's computer/laptop and send and receive signals to and from the other modules. The Smart Lock Box will need to receive a signal for when to lock or unlock based on the input gathered from the user. The pressure sensor on the chair will send a signal to the main communication module to determine if the user is actually sitting in the chair. The vibration mechanism will need input from the main communication module to determine to turn on. Since the modules do not require internet access, will be within a close range, and only transfer basic signals, bluetooth will be adequate.

There are three classes for bluetooth modules. Class 1 has an output range of about 100 mW, Class 2 has an output range of about 2.5 mW and Class 3 has an output range of about 1 mW. The distance between the two bluetooth devices is about 100 meters for Class 1, 10 meters for Class 2 and 10 centimeters for Class 3. The Class 2 Bluetooth modules will be adequate for our design since the devices will not be more than 10 meters away from each other.

Bluetooth Low Energy (BLE) and Bluetooth Classic are two options when it comes to bluetooth modules. They both operate in the 2.4 GHz ISM frequency band. Bluetooth Classic was designed to continuously transfer data from one device to another within a close range. As the name suggests, Bluetooth Low Energy was designed to consume less power and is ideal for applications that only need to share small amounts of data periodically. BLE remains in sleep mode until a signal is found.

An nRF24L01+ module is another option for wireless communication. These modules are very small and inexpensive. By using two of these modules on both MCUs, they could communicate to each other without the devices having to be paired first like bluetooth devices would. It can connect to any 5 V microcontroller without the use of any logic level converters.

3.4.1.1 Wireless Communication Hardware

For our project, we are looking to transfer data between two computational devices. This can be done by either adding a bluetooth module to both devices or just one if the other is already equipped. The devices will need to be compatible and have the proper communication ports required. Some of the computational device options discussed above in section 3.3 have built in wireless communication features, while some do not. In the case that an additional wireless module is needed, a few will be summarized below.

3.4.1.1.1 HC-05

The HC-05 is a bluetooth module that can be added to an MCU to provide bluetooth capabilities. It has an operating voltage of 4V - 6V and an operating current of 30 mA. It works within a range of 100 meters, follows the IEEE 802.15.1 standard and uses frequency hopping to minimize interference. This bluetooth module can operate as the master, slave or master/slave and can be interfaced with devices enabled with bluetooth such as smartphones, laptops or other microcontrollers. It cannot transfer large data such as audio or photos. The module uses serial communication (USART) and is TTL compatible. This module has 8 pins, each with a designated function. This device can be purchased for \$7.99 for one or \$12.59 for a pack of two on Amazon.com. Table 4 shows the pin name, numbers and descriptions.

Pin Number	Pin Name	Description
1	Enable/Key	Toggle between Data mode (set low) and AT command mode (set high). Default is Data mode
2	Vcc	Powers the module. Connect +5V supply voltage
3	Ground	Connect to system ground
4	Tx - Transmitter	Transmits Serial Data
5	Rx - Receiver	Receives Serial Data
6	State	Connected to an on board LED, can be used to check if Bluetooth is working properly
7	LED	Indicates status of module <ul style="list-style-type: none"> ● Blinks once in 2 sec = Command Mode ● Repeated Blinking = Waiting for a

		connection in Data Mode <ul style="list-style-type: none"> • Blinks twice in 1 sec = Successful connection in Data Mode
8	Button	Used to control the Enable/Key pin to toggle between modes

Table 4. HC-05 Pin Configurations

3.4.1.1.2 Bluefruit LE SPI (or UART) Friend

The Adafruit Bluefruit LE SPI Friend is a BLE module that can be connected to a microcontroller to give it wireless connectivity. As the name suggests, this device connects via SPI, using the four pin interface (MISO, MOSI, SCK and CS) plus an additional fifth GPIO pin for interrupts. It runs at clock speeds of up to 4MHz. This device is much more advanced than the HC-05 as it has an ARM Cortex M0 core that runs at 16 MHz, 256KB of flash memory and 32KB SRAM. It has 5V safe inputs and has an onboard 3.3V voltage regulator. This device is priced at \$17.50 on Adafruit.com. They also offer the same product with UART connectivity for the same price.

Both options have the basic VIN and GND pins for power supply and ground. The SPI version has the four pins previously listed as well as the fifth IRQ (interrupt) pin to notify the microcontroller when there is data available. The UART version includes the transmit and receive pins, TXO and RXI, along with the CTS (clear to send) pin to notify Bluefruit it can send data to the MCU and the RTS (ready to send) pin which will be low when it can send data to the Bluefruit. The SPI version has a system reset pin and the UART version has a mode selection pin. They both have a DFU pin which allows the module to acquire firmware updates. On the other side of the device, they both have reverse side breakouts including a factory reset pin and the output from the 3V regulator. They each have a few unique additional breakouts as well.

3.4.1.1.3 HM-10

The HM-10 is a bluetooth module with Bluetooth 4.0 and can be connected to an MCU to provide it with wireless capabilities. Of this module's 34 pins, only four are used to establish communication using UART (UART_TX, UART_RX, UART_CTS and UART_RTS). The HM-10 has a 2.4GHz ISM band and can send and receive with no byte limit. It has 12 GPIO pins, 128 or 256KB programmable flash and 8KB SRAM. Its operating voltage ranges from 2V to 3.6V and works within a 100 meter range. This device is available on Amazon.com for \$9.99.

3.4.1.1.4 Wireless Communication Module Comparison

Table 9 compares the wireless communication module options discussed in the above sections.

		Wireless Communication Modules			
		HC-05	Bluefruit LE SPI Friend	Bluefruit LE UART Friend	HM-10
Features	Price	\$7.99 (1) or \$12.59 (2)	\$17.50	\$17.50	\$9.99
	Operating Voltage	4V - 6V	3.6V - 6V	3.6V - 6V	2V - 3.6V
	Range	100 m	10 m	10 m	100 m
	Communication	USART	SPI	UART	UART

Figure 9. Wireless Communication Module Comparison Chart

3.4.2 Wired Communication

A wired connection is required to connect the microcontroller of choice to the user's computer. The lock box will also be hardwired to the MCU to reduce the complexity of the entire system overall, having the communication module and locking system within the same setup. Separate from the smart locking apparatus will be the vibration module, also requiring some wiring for the purposes of weight sensing and vibration stimulation of the user. There will also need to be a method of wired communication between parts used in the designed PCB board. This section will be used to discuss various methods of data communication via wired medium.

3.4.2.1: UART

Universal Asynchronous Receiver and Transmitter (also known as UART) is a method of communication used between two devices. Three operations of UART are used: simplex, half-duplex and full-duplex. Simplex allows only for data transmission in one direction. Half-duplex contains one wire and allows for data transmission in either direction, but not both at the same time. Full-duplex communication includes two wires, allowing for bi-directional transmission at the same time. For the purposes of this project, a UART system with bi-directional communication (or the full-duplex setup) might be the strongest contender: there is a desire for constant flow of information between the computer, smart locking/ communication module and vibration/ pressure sensing module to ensure essentially real-time focus tracking. Other advantages to using the UART communication system include its simplicity, its ability to be used without a clock, and its implementation of a parity bit for error checking. Disadvantages to this system is its small data frame (limited to 9 bits), inability to use multiple masters

and slaves which may pose a problem considering this project includes 3 systems, low speed and need to have close baud rates with other communication devices.

3.4.2.2: I2C

Inter-integrated-circuits (also known as I2Cs) is another method of wired communication, but primarily used on the smaller scale for things such as modules and sensors. I2Cs utilize a bus and addressing communication system, allowing for multiple devices (sometimes over 100) to be connected to the motherboard while maintaining clear communication pathways. Therefore, this method of wired communication is useful for projects requiring many moving parts, such as multiple sensors, pins, etc. Wiring can sometimes be simplified so that multiple devices share the same datapath. This simplification can create a slower system overall. In fact, I2C communication systems are typically slower than SPI systems, with the speed typically being determined by data speed, wire quality and external noise. One difference between I2C and UART is its ability to run on a synchronous clock, where the low period of the SCL clock is determined by the device with the longest clock period, and the high period by fastest.

Benefits to using the I2C communication method is its low pin count with the inclusion of multiple devices, multi-master and multi-slave support, simple bi-directional communication for multiple devices and adaptability. Disadvantages to using I2C design are its slower processing speed (it requires the use of pull-up resistors & open-drain design), larger space requirement (leaves less room for a “sleeker” design and more costly approach due to more material), and complexity with a large amount of devices. Not many devices are being utilized in the creation of this project, so setting up this type of communication system would not be complex. Given the circumstances of our design, I2C may not be the best option, and SPI may be a better contender, given that it has a faster speed overall. More information on the SPI communication system is mentioned below.

3.4.2.3 SPI

Serial Peripheral Interface (also known as SPI) is a method of communication protocol designed to connect microcontrollers. SPI operates faster than I2C and UART because it operates at a full-duplex where it can send and receive data simultaneously and has a data transmission rate of 8Mbps. SPI is used when timeliness is an important factor, such as reading input from weight sensors used in our project design. Communication is done through 4 ports: MISO, MOSI, SCLK and NSS. With SPI, multiple devices can be connected as slaves, the only downside with this mode of communication is that it requires more ports than I2C and UART. Each slave has a unique slave enabled signal (NSS) which makes the hardware slightly more complicated than I2C but negates the need for the slave addressing system used in I2C. One advantage of using SPI is that it

has no start or stop bits like UART does which allows for continuous data transmission. Another advantage is the use of separate MISO and MOSI lines allowing data to be transmitted and received simultaneously. Some disadvantages of using SPI include the high number of ports necessary, the lack of error checking where UART uses the parity bit and the fact that only one master is supported with mode of communication. For our design purposes, this communication protocol seems ideal for use with weight sensors.

3.5 Vibration Module

The vibration motors that will be located in the seat of the chair are the main source of feedback to the user to alert them when their attention has drifted for the allotted period of time and get them to regain their focus. The motors need to be small enough that they can easily fit in the chair module, but also strong enough for the user to feel the vibration alert. The purpose of this section is to research possible vibration technologies that could be implemented in our design.

3.5.1 Coin Vibration Motors

One of the most common types of vibration motors today is the coin vibration motor. Its flat, round shape and small size has made it a popular choice for devices such as cell phones and wearable devices that have a need to alert the user with a vibration. The coin vibration motor is a type of eccentric rotating mass (ERM) motor. The vibration is formed by the rotation of this eccentric mass around an axis. The offcentered mass causes an instability in the motor, which creates vibration. In the coin vibration motor, the eccentric mass is contained within the casing of the motor. This makes the motor easy to implement in a variety of ways as the user does not have to make space for the mass to rotate where nothing will impede with it. The fact that this type of motor is flat would be beneficial in our design as far as including it in a chair module that the user would be sitting on. However, the small size of these motors would likely not provide a strong enough vibration for the user to feel.

3.5.2 Linear Resonant Actuator

The linear resonant actuator (LRA) is similar in shape and size to the coin vibration motor and is even used widely in similar products such as cell phones and other mobile devices. Unlike the ERM system used in the coin vibration motor, the linear resonant actuator uses a spring and mass system to create its vibration. This spring and mass system is driven by an AC signal, unlike most other vibration motors which are driven by DC motors. Due to requiring an AC signal to drive them, linear resonant actuators have a narrow bandwidth for the frequency at which the vibration will occur. LRAs are a great choice for haptic feedback as they have a quick response time for when to begin and end vibration. Similar to the coin vibration motor, the linear resonant actuator would be a

good choice for the chair module since the vibration mechanism is enclosed in a metal casing. However, LRAs are too small to effectively create the vibration necessary to be felt by the user.

3.5.3 Cylindrical Vibrating Motor

Cylindrical vibration motors are another type of ERM. Unlike the coin vibration motor where the eccentric mass is contained within a metal case, the mass is attached to a DC motor where it is not contained in any way. Since the eccentric mass is not enclosed, this could be an issue as far as containing this type of motor in the chair module. The design would need to make room for the motor to rotate the mass freely without any chance of it getting caught on an impediment of any kind. Compared to the linear resonant actuators and coin vibration motors, the cylindrical vibrating motors have a greater potential to be scaled up in size, thus creating a stronger vibration to alert the user. A cylindrical vibrating motor is also something that could be homemade rather than purchased from a commercial vendor. This could be done by attaching an eccentric mass to a DC motor. Doing this would allow us to choose a motor and a mass that are large enough to cause a vibration that the user will feel and become alerted by.

3.6 Smart Locking Mechanism

One of the primary reinforcement tools used to encourage focus in this project is the Smart Lock Box mechanism. This day in age, it can be difficult for the average person to stay disconnected from their phones for extended periods of time: people are essentially addicted to their own personal smart devices, and this can lessen their attention span, especially if their device is constantly bombarded by notifications. To allow for disconnection from these devices in a controlled, timely increments, the smart lock box system will be implemented to manage one's ability to use their devices as a distraction while trying to read and focus on their readings, assignments, etc.

The purpose of this section is to explore research into various Smart Locking systems, including (but not limited to) research on various types of locking mechanisms, fail-safe mechanisms for retrieving locked items in emergency situations, and alerting mechanisms to help the user identify the option for quick study breaks.

3.6.1 Classification of Smart Locking Systems

Before delving into the various types of smart locking methods, it is important to discuss the parameters needed to identify something as a "smart lock". Since our "Smart Lock Box" will be implemented along the lines of a "smart locker", a patent meant for "Electronic lock and electronic locking system for furniture, cabinets or lockers" was investigated [1]. The following claims were made in the process of identifying a smart locking device, as it pertains to our project's goals:

- Contains a case for the fixing of an inner part of a door of a piece of furniture, cabinet or locker;
- An electronically activated locking mechanism;
- An electronic access means for receiving access data;
- A power module being supplied by at least one battery;
- A wireless communication module; and
- An electronic control module configured to operate the lock in:
 - An “offline” mode: the lock box is autonomously activated based on the data received; and
 - An “online” mode: the data received is sent to a control unit, where activating instructions are processed and sent back to the lock to determine the status of the lock (locked or unlocked). Once this status is achieved, offline mode is initiated.

(specifications provided by patent [US10515496B2](#))

An extension on the claim above states that when the electronic lock is adapted to communicate with a central control unit, the wireless communication module remains deactivated (aka no communication is present between the module and the electronic locking device). Essentially, with the extension of this second claim, the goal of our smart electronic lock box has been defined. We want our lock box to receive locking information only when a specific message is sent from the primary control device, telling it whether to lock or unlock, based on the status of the user’s focus streak or a signal sent indicating a timed break session.

3.6.1.1 Original Claim Modifications

For the purpose of our smart locking lock box, however, a few differences arise in our design. For example, a third state of operation is taken into consideration: that of fail-safe design (unexpected shut-down). Our design will put in place a system for when power is cut from the box: Since the primary purpose of the lockbox is to physically distance objects from the user rather than keep them secure, the best option for a fail-safe is to release the locking mechanism, rather than keep it secure. This will be discussed further in another section.

The power module supply is also another claim to be researched: our team would like to have this smart lock box and communication module powered by USB connection to the computer in use. Further research on this topic is explained more into this paper.

3.6.2 Types of Electronic Locking Mechanisms

In the market, there are a variety of smart locking systems available with different mechanics. This section will be used to discuss how a handful of locking systems work.

3.6.2.1 Electronic Deadbolt Lock

The deadbolt lock is recognized in many homes across the country, being one of the primary methods for locking intruders out. It is a surface-mounted or internal locking apparatus, constructed with the goal of keeping the contents of the container/room safe from outsider intrusion. Surface mounted deadbolt locks attach the door to its frame using a sliding bolt. These are recognizably mechanical, as seen by the average household door lock. They typically require the use of a key or a deadbolt knob. This type of lock is also mechanical heavy, and does not require much electronic work to be implemented. The internal deadbolt locking system, shown in Figure 10, is placed inside of the door in question, with the strike to lock into the frame of the doorway. This provides a more secure locking mechanism, and one that is harder for intruders (or prying user hands) to dismantle.



*Figure 10. Example of Electronic Deadbolt Lock with Included Keypad for Safety
(image from amazon shopping or Milocks Lock)*

If a deadbolt lock were to be chosen for the purpose of this project, the Surface deadbolt lock would be the preferred option. Since there is no dire need to separate/secure the user's personal items for extended periods of time, there is no need to develop such advanced locking mechanics. With constraints such as cost and time at stake, the surface mounted option also provides a cheaper option for locking compared to the internal system.

3.6.2.2 Electromagnetic Lock

A less mechanical alternative to locking is exhibited through the use of the electromagnetic locking system. Similar to the surface-mounted deadbolt lock, electromagnetic locks are also installed on the surface of the locking apparatus, and they require low power and low maintenance to operate. One noticeable difference between these kinds of locks and deadbolt locks is the placement: These types of locks are typically located along the header of the door being locked. In addition, this lock is also most effective when the user is trying to pull the door towards them, rather than through the door opening. Figure 11 shows a typical electromagnetic lock.

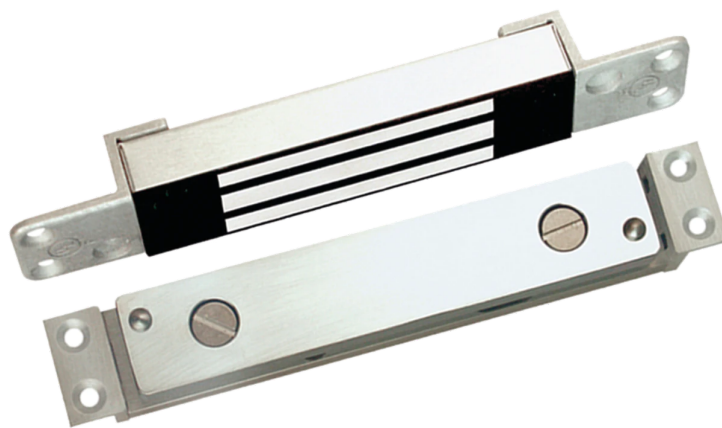

Figure 11. Image of a Typical Electromagnetic Lock (specifically the Securitron SAM2, provided by Locksmith Ledger International, permission pending). Top item is the ferromagnetic material typically attached to the door, bottom is the metal piece attached to the frame.

Basic swing door locks are formatted in many E-Shaped metal plates adjacent to each other, made of some type of thin ferrous material (the larger size and quantity of these pieces determines the strength of the magnetic holding force). The magnetic field to create the magnetic holding force is produced when a DC current flows through a copper wire winding. Combined with other pieces of electronic equipment, these components are placed into a housing consisting of non-ferrous material to protect the vital magnetic components, and some are even covered with a protective coating to prevent corrosion. An armature system/strike plate is also included to create a flush magnetic connection when the lock is activated. The larger the strike's surface area, the more secure the hold will be. In terms of commercial/institutional usage, these types of electromagnets are powered with 12-24 VDC, drawing between 500-600mA. Low amperage draw allows for stronger holds in the long run. When it comes to smaller applications, however, such as magnetic locks to keep display cases, cabinets and desks secured, extra credentials such as a key code or scanner may be used.

Electromagnetic locks can be used for any variety of door/encasing, however. They can be used for swing doors and sliding glass (or any other recessed-type) doors just to name a few, offering versatility with the goal to keep precious items safe from prying hands. When it comes to a sliding door system, extra protection is provided by the shear force present between magnet and sliding door. Compared to the average minimum 400lb protection from a swing door system, recessed/sliding doors offer around 600lb safety: essentially not movable. [9]

3.6.2.3 Delayed Egress Magnetic Lock

One variation of the electromagnetic lock system is the Delayed Egress Magnetic Lock system. More of an integrated smart locking system, the main purpose of this lock is to notify when a person is trying to escape through a secondary door. When this type of door is attempted to be used, an alarm may sound, remaining shut for a short period of time in order to allow other persons to come and assist the one trying to use the door.

Two variations of this locking style are typically used. The first of which is a built-in pressure sensor which is activated when a push-open door has force applied to it (aka a fire escape door inside of a school, hospital or other building). The second is a type of non-latching cross bar microswitch which, when the door's escape bar is pressed, activates a siren connected to the magnetic lock system. After the siren delay has passed, the lock is released and the door is able to be opened.

Some common features of this design are door position notifications (information provided by the system's sensors relay back whether the door is opened or closed), voltage sensing (identified voltage draw and a controls system adjusts it for optimal performance), and anti-tamper switches/sensors.

3.6.2.4 Potential Electromagnetic Locking Issues

When any type of magnetic system is being implemented, the number one concern is with regards to residual magnetism. This occurs when the ferrous material within the metal portion of the electromagnetic lock becomes itself magnetized, resulting in a stronger magnetic attraction between both sides of the lock when the system is not powered. This poses the issue of a permanently locked door when the system is not powered at all.

3.7 Power Supply and Battery Storage Systems

This section will be discussing research and decisions related to power storage and battery options. There will be two to three different segments requiring power, including the smart locking apparatus, chair vibration module, and communication module. A few

areas of interest include USB supplying options (connection via computer for ease of integration), battery sizing options, battery composition and AC-DC Conversion.

3.7.1 USB Power Supply

For the purpose of the smart lock connection, it would be beneficial to include a USB type C connection as part of the electromagnetic lock design, depending on how much power is needed to create a secure magnetic connection. However, in the case of the vibration chair module, little energy is being consumed in operation. Therefore, the exact amount of energy needed must be computed, so the type of USB to be implemented will be explored later in this document, although it will most likely include some type of Dedicated Charging Port, if this type of charging system were to be implemented. However, if something large like a single lead-acid battery were to be used, no charging port may be implemented at all.

For the purpose of this project, USB type B minis will be the primary source of power and coding for both of our microcontroller boards. Having a quite simplistic pin layout with 5 pins (Vcc, Data In, Data Out, X, and Gnd), it will be easy to integrate and streamline across both microcontroller devices. Also, knowing that the Mini USB-B can supply a voltage of 5V from its source, we can use this knowledge to design a 5V to 3.3V regulating system to be used for both microcontroller devices for the purpose of powering the controller for programming purposes.

3.7.2 Energy Storage Systems

A wide variety of energy storage systems are prevalent in the market, and they all follow three important guidelines: providing quick compensation (Power Quality), storing capabilities to “bridge” energy gaps from one source to another (Bridging Power), and shifting energy for extended periods of time (Energy Management). The most important aspects to look at for the purpose of keeping our chair vibration module powered are Bridging Power and Energy Management because the desired goal is for the chair to be powered for extended periods of time (8 hour work day). Batteries have been deemed the most suitable form of energy storage compared to other alternatives, such as capacitors and fuel cells, for it is a healthy medium between energy density and power density ratings, allowing for a wide range of use. The following sections will go more in depth as to the types of batteries researched, estimated sizing, state of charge estimation methods and charging mechanics.

3.7.3 Battery Types and Sizing

The remote chair module is to be designed with a battery that lasts at least 8 hours (or the duration of a typical workday), so the size of the battery must be calculated

accordingly. Another thing to consider when choosing the size of our battery is the type of power consumption: are the tasks requiring electricity actually drawing a lot of power?

Another thing to consider is the shape style of the battery. Battery shapes and sizes include cylindrical, button, prismatic and pouch. The cylindrical battery is one of the most recognizable battery types, often displayed at the forefront of marketing schemes for Duracel and Energizer. This style of battery offers more safety features when compared to other formats, is low cost, and is commonly used for portable device applications. Air pockets in the design of the battery also allow for greater thermal regulation. Cylindrical cells often do not change size either, when compared to its counterparts. One downside to this style of battery is its “less than ideal” packaging density: most cylindrical batteries have a smaller capacity-to-volume ratio when compared to its more modern flat battery counterparts.

The button cell (or coin cell) battery is used for much smaller portable devices, such as electronic key fobs or various medical devices. They are small and inexpensive to build, and they have the ability to offer higher voltages when stacked together in a cylinder. One of the biggest downfalls to this design are its safety concerns: if the battery is charged too fast, there is a risk for overcharging and swelling of the battery.

The prismatic cell battery pack is one of the first solutions to creating a slimmer battery pack for electronic usage. With a design reminiscent of a pack of chewing gum, this battery uses a layering technique, separating the anode and cathode with some sort of electrolyte or separator. Unlike the cylindrical battery design, this style tends to swell with time, and breathing room within the device must be taken into consideration to prevent interaction with other components for as long as possible.

The pouch cell battery offers a fully sealed battery design, used in consumer, military and automotive applications. It provides a simple, lightweight solution not seen in prior battery designs. One of the biggest draws towards utilizing this design is its packaging efficiency: the pouch style achieves over 90%, which is much greater than other battery models. It's very light weight and provides high current charging opportunities for portable applications. One of the biggest concerns for this design is safety: extreme swelling can occur, posing risk for destroying surrounding hardware, as well as to the user. When these batteries are punctured, the gas escaping these packs can ignite. However, as technology has evolved, this concern has been taken into consideration, and new manufacturing methods have been developed to mitigate the potential for swelling, such as the implementation of temporary “gasbags” to release any swelling as a result of the manufacturing process. A comparison of different battery types is shown below in Table 5.

Manufacturer	Type	Price (\$)	Quantity	Voltage (V)	Weight	Size (inches)	Amp Hours	Rechargeable?
Expert Power	Lead Acid	\$21.34	1	12	4.3lbs	6"x 2.5"x 3.7"	7	Yes
Amazon Basics	AA	\$29.23	8	1.5	.7lbs	9"x 6"x 1.8"	2	Yes (+ charger)
LiCORE	Lithium Ion	\$89.99	1	12.8	1kg	6"x 2.5"x 3.7"	7	yes
Duracell	Ni-MH	\$25	10	1.2	1oz	0.57" x 1.99"	2.7	yes
Amazon Basics	Lithium Ion	\$11.49	6	3V	.48oz	0.67" x 0.67" x 1.35"	n/a	no

Table 5. Battery Comparison Chart

A comparison of each of the battery packs is mentioned above. For the purpose of this project, we require something that is compact, but also able to deliver the power that we need. The LiCORE battery does deliver most of our requirements with the addition of a BMS system, however the price range is far from what the team is comfortable spending on. The expert power lead-acid battery has a great charge for the voltage amount, Looking at the AmazonBasics Lithium Ion batteries, they are relatively cheap for their count and voltage size. The downfall to this, however, is its inability to recharge. Because of this reason, it has been thrown out in the selection process. Duracell, although they have a more appealing price range, are not as effective as the other batteries listed in this table.

For the purposes of this project, the top two contending options are the AmazonBasics AA batteries and the Expert Power Lead-Acid Battery. The AmazonBasics batteries are more compact, but at a lower voltage value of about 1.5V. This system would still require some sort of battery management system to ensure all batteries are discharged at the same rate (discussed in further sections), which would be another add on to our project. However, it does come with its own battery charging system.

On the other end of the spectrum, the Expert Power Lead-Acid Battery eliminates the fear of varied battery cells because it includes one giant cell. In addition, it comes at a

voltage value of 12V and a life of 7amp hours, which allows our vibration chair module to run for a long time without the need for charging. It has the ability to provide a lot of power to our system. However, the size and weight of the system takes a toll on the mobility of our final system design, which the team wanted to be generally portable for the user. One fix to this would be crafting a strapped straddling system for the chair that the battery, PCBs and microcontrollers to be housed in.

The final decision, as of senior design 1, is to use the lead-acid battery for its large amount of available power and cheap price point. Staying within the budget is one of the primary concerns for our design, so this item takes top priority.

3.7.4 Battery State Of Charge Measurements

The chair vibration module is to be fully removed from the communication ecosystem connected via USB. For the purposes of streamlining design, the chair should have a remote rechargeable battery charging the entire system, with the intention to be reusable for charge. Therefore there must be some sort of “battery status” indicator either on the chair module itself, or integrated onto the smart locking system in a visible location for the user to be able to monitor the status of the battery and know when it must be recharged.

State of Charge can be calculated in a variety of ways, but they all follow the same basic conceptual equation stated below:

$$\textit{State of Charge} = \frac{\textit{Current Battery Energy Stored}}{\textit{Total Battery Capacity Energy Stored}}$$

When trying to accurately measure the state of charge of the battery in question, it is important to measure the energy currently in the system rather than just the Amp hour discharge, since lithium ion batteries do not tend to follow a linear discharge pattern. As ions diffuse in and out of the battery cell, transient charges are diffused between the surface of particles and the electrodes of the chemical battery and the bulk interior. Therefore, the method of Coulomb Counting is used within a Battery Management System to keep track of the charge of the battery, since there is technically no true voltage sensor out on the market to measure voltage difference within the battery cell.

With the amount of time allotted for Senior Design 1, this goal cannot be attained. Although it would be a great addition to another iteration of this project (if it does go beyond the scope of this graduation class), the 16 weeks allowed for our group to design this apparatus was not enough to develop a fully operational BMS with a remote notification system for a state of charge estimator. However, with the extra time given

from our group starting in the spring semester, there is a possibility of the concept being further explored during the summer months.

3.7.5 Battery Management Systems

For a variety of batteries to be implemented into a single system, a battery management system may need to be implemented. Essentially, when looking at a variety of batteries implemented in a system, none of them are ever truly created with the exact same specifications: some may have more charge than others, depending on the conditions of the materials they were made with at the time and how well they reacted in the manufacturing process. Some internal factors that can lead to variances in batteries include variations in physical volumes of the batteries depending on the manufacturer, variations in their internal impedance, and differences in their self-charging rates. External issues include the protection IC channels' unequal discharge rates per battery, as well as the thermal differential across the entire pack, where some cells may experience higher temperatures than others, resulting in higher rates of discharge. This imbalance is seen below in Figure 12.

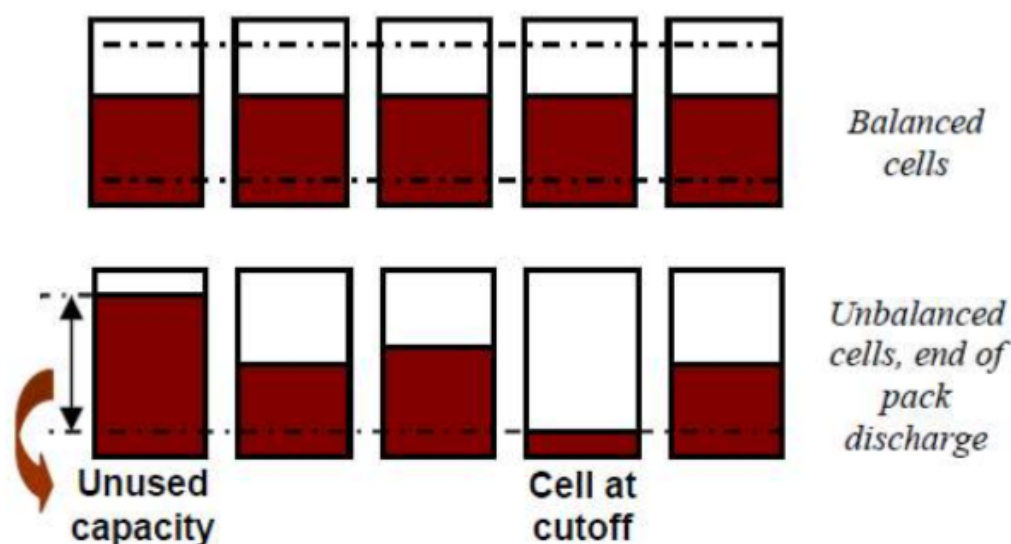

Figure 12. Battery Balancing: Balanced vs Unbalanced
Graphic courtesy of The University of Texas At Dallas (pending approval)

The above figure exercises the concept of “battery balancing”. The below row of batteries contains a pack of unbalanced power sources with varied energy contents. Essentially, if all batteries are used in the same manner in series, being drained at the same rate, the battery with the lowest energy level determines the longevity of the circuit as a whole. In the first row, a battery balancing system was implemented, allowing for the battery with the largest charge to dissipate first, followed by the next

ones until all reach the same level. This method then allows for all batteries to eventually be discharged at an even rate, therefore allowing the recharge process to be more efficient in terms of all being charged at the same rate.

For balancing batteries in a battery system, there are two main algorithms: the Passive (dissipative) Balancing method and the Active (non-dissipative) balancing method. The passive approach utilizes shut resistors to dissipate energy, are low cost, non-complex, and are primarily used for Lead-acid and Nickel batteries. Disadvantages to this design are that energy from the battery storage system can be wasted, and extra heat can be introduced into the system as a result of the dissipative resistors.

On the other hand, the Active balancing method for batteries utilizes inductors, capacitors and/or transformers in circuits to perform balancing between cells, or between cells and battery packs. These types of circuits are also used for lead-acid and nickel batteries, but are also applicable with lithium-ion batteries as well. One advantage this has over the passive method is its ability to transfer energy between entities, rather than dissipating it, never to be used again. The disadvantages to this method, however, is that these circuits can become relatively complicated and costly, with the addition of a required control algorithm.

3.7.6 Battery Charging Methods

While researching USB power systems, the concept of a Dedicated Charging Port (DCP) was introduced. Since the battery for our vibrating chair module does not necessarily need to receive any data in the charging process, It would be a good idea to implement one of these ports into our design. That way, when the module must be charged, it can be done in a fast manner.

In addition, there must be precautions set to prevent overcharging in the system: Our lithium-ion battery cannot receive more charge than is originally intended or else the life-span of the battery will be shortened (its state of health will deteriorate, requiring a new battery to be installed earlier than expected). Although the purpose of this project is to provide a working prototype for a short presentation, implementing a proper charging system would showcase the maturity of our team's design skill.

The last option for charging the batteries in our system would be through using rechargeable and removable batteries. For example, some battery packs can be taken from their container and placed into a standardized battery charging outlet plug, which helps to indicate when the batteries themselves have been fully charged. This option would be utilized if there is not sufficient time within the first semester of senior design to create a fully operational rechargeable battery design. Since the purpose of including

a battery in this project is to provide a completely remote chair module, even using these types of batteries charged by an external circuit would be sufficient in attaining that end goal.

Due to the time constraints of Senior Design 1, a charging system cannot be completed for the semester. With extra time allotted over the summer, however, the concept of a charging apparatus for this remote module can be further investigated, but for the purpose of this paper, it will not be included.

3.7.7 AC/DC Inclusion Investigation

The only portion of this project that questionably requires some type of AC/DC conversion is the charging apparatus for the vibration chair module. The battery for the vibration chair module will most likely be powered via a dedicated USB charging port, which can allow for versatility of AD/DC blocks coming from a typical (based on our location, American) 120 volt outlet.

When discussing the electromagnetic locking portion of this experiment, a larger power draw is discussed: the typical stats of the smaller electromagnetic lock are 12 Volts with about a 100-110 mA current pull. The USB system from the computer might not be able to power both the microcontroller device and the lock at the same time, so the AC/DC converter may need to be implemented on this system for purposes of ensuring proper power delivery to both the lock and microcontroller.

3.8 Lights/Displays

Small lights will be one of the primary methods for notifying the user of different systematic happenings, such as when the user would be allotted a small smartphone break (green LED), when the smartphone break is to be terminated (red LED), as well as a wireless battery SOC monitoring system. This section will discuss different types of LEDs and displays to determine which type will be best implemented into our concentrating system.

In terms of implementing a small display in our system, there is not much need for one. Some of the options for Microcontroller devices that have been previously explored in section 3.2 contain a small LCD display which could be utilized for system monitoring or notification. LCD stands for Liquid Crystal Display, and typically has a higher resolution than using singular lights, as well as the ability to display a multitude of colors for the user to experience. The MSP430FR6989 board contains a small LCD display, which we had previously utilized in Embedded Systems, a class offered for electrical and computer engineers. In this class, the display was used to visualize various functions,

such as a stopwatch, measurements, shapes and other various texts. If time allotted, this LCD display could be used as the State of Charge Estimation visual, alerting mechanism or any other visual stimulant.

If a simpler approach were more favorable in notifying the user, using individual LEDs might be a better option. Being a cheaper option than an LCD display, these light emitting diodes are small, vibrant, and easily integratable onto PCB Boards if need be, with only a few pins to be utilized (most single LEDs have less ports to worry about than the typical LCD). LEDs usually tend to be thinner than LCDs with a better power consumption and color contrast.

However, as previously stated, the state of charge estimator is not currently planned for this stage of the design process. Therefore, only a small LED notification system will be implemented, and the inclusion of an LCD screen will be determined over the summer months/ beginning of senior design 2.

3.9 Switches

When discussing the design of both the smart locking and vibration modules, questions arise as to how these external power options can be activated, given that they most likely require some sort of upgraded power sources in comparison to what the typical microcontroller would be running off of. Thus, the integration of external switches must be explored to activate things such as the electromagnetic lock, pressure sensors and vibration motors. This section explores a variety of switches to hopefully narrow down the market selection to a few viable options that we can implement into our design.

3.9.1 Electromagnetic Switches

Electromagnetic switches are seen all over the market in various forms. These are representative of the typical toggle switch, push button, rocker switch, etc. The main purpose of these switches is to open/ close a circuit based on input from a user enacting a physical action. These types of switches may be implemented into our design in case someone wants to activate/ deactivate portions of our apparatus (i.e. if someone were to deactivate the smart locking apparatus because they do not have a device and only wishes for the chair module to be activated, or if the computer were to be deactivated, the system would be turned off to save power and prevent unnecessary decay of the equipment).

With regards to our concentrating system, a variety of these switches may be implemented. For our smart locking system, we wish for our magnetic lock to be activated until a signal is received, indicating that a break is to be taken. Therefore,

some sort of NC switch will need to be implemented. On the other hand, the vibration chair module will not be actively stimulating the user until the signal is received. Therefore, a NO switch would be best implemented. In addition to these functions, as stated before, it may be beneficial to include master power switches for each of the module designs to allow for power saving options, in case some operations within the apparatus are not to be used for certain reasons.

3.9.2 Relays

A relay is known to be a specific type of electromechanical switch, usually consisting of four different parts working together: an electromagnet, armature, spring and a set of contacts. Common in many things, such as household appliances or anything with any type of electronic control, these devices receive signals and send the signal to other pieces of equipment to either turn on or off.

Solid state relays and semiconductor relays both work like the typical mechanical relay, but are purely electronic, being primarily composed of two different sides: a low current control side and a high current load side. Both a line and a load must be present for the relay to function properly. These types of relays are usually constructed with MOSFETs and TRIACs. Some benefits to these types of relays are their lack of need for movable parts, no arcing between contacts, high reliability and long operating life. Some pitfalls to these types of relays include their higher price point when compared to their more mechanical siblings, lower volumetric efficiency, restriction to NO configuration at single pole and their greater prevalence working in AC type power.

In relation to this project, electromechanical relay switches may be the best option, primarily for their price and versatility. As previously stated, both normally open and normally closed switches will be used in this project, so it may be better to stay with the same switch producer (if possible) in order to limit too much variety in our bill of materials. However, further research into other types of switches is necessary before making a final decision.

3.9.3 Power MOSFET Transistors

A Power MOSFET is a special type of Metal Oxide semiconductor field-effect transistor, capable of performing the same duties as a normal MOSFET at higher power levels. Based on its higher power functioning ability, it can also be labeled as a V-MOSFET, or VFET for short. This would be a faster, more reliable option when compared to the relay mentioned previously. These transistors come in three major modes: such as the n-channel enhancement mode, p-channel enhancement mode and something reminiscent of an n-channel depletion mode. For the purposes of this project, the

n-channel enhancement mode MOSFET will be taken into consideration as the switch for our electromagnetic locking system.

The Power MOSFET works essentially like a voltage control switch. When a voltage is applied to the gate (or the MOSFET is switched into the “on” state), a resistive behavior is seen between the drain and the source terminals (as a reminder, MOSFETS typically have three terminals: the source, the drain and the gate). As long as the voltage surpasses that of the threshold value, then the switch can be activated. Otherwise, if the threshold voltage is not reached, no resistance is experienced between the source and the drain, therefore allowing the circuit to remain completed.

When looking to implementing a power MOSFET into a circuit, four major things must be taken into consideration:

- 1) The location of the Gate, Drain and Source Terminal pins.
- 2) Understand what the threshold voltage of the transistor is (typically labeled as V_{GS} or V_{TH}). For the purposes of this project, it would be best to have a threshold voltage at or below 3.3V, given that the microcontroller to be utilized in this project outputs this voltage level.
- 3) Find the Drain-to-Source Resistance ($R_{DS\ ON}$)
- 4) Find $R_{\theta JA}$ (or the junction to ambient thermal impedance) and maximum junction temperature to calculate the maximum temperature of the power MOSFET device. If the calculated temperature exceeds that of the allowed, then a heat sink may need to be implemented.

All of the above characteristics can be identified within the specific part’s data sheet.

Since it is a goal of ours to have the default setting of our smart lock box to be magnified for the purposes of extended study, this option does seem suitable for our design. Therefore the two types of switches that can possibly be implemented are the relay and the Power MOSFET. Table 6 explores a variety of power MOSFETS taken into consideration for this project.

Product #	IRFS7530-7PPbF	2156-NVD4806NT4 G-ND	CSD13385F5
$V_{GS(TH)}$ (V) min	2.1	1.5	0.5
$V_{GS(TH)}$ (V) max	3.7	2.5	1.2

$R_{DS(on)}$ (mOhms)	1.4	6.0	18
$R_{\theta JA}$ ($^{\circ}C/W$)	40	56.7	90
Cost (\$ per 1 units)	\$38.80	(expensive bulk option only)	\$3.93

Table 6. Power MOSFET Comparison Guide

Because MOSFET IRFS7530-7PPbF operates at a gate threshold voltage of 2.1-3.7V, this seems to be the best option. Since our microcontrollers run on a voltage range around 3.3V, this voltage reading resonates with that of our project, unlike the other ones mentioned in the above table.

3.10 Diodes

Diodes are an important part of an electrical circuit. For uses in AC power, they ensure that current is flowing only in a single direction, and permit current flow in the reverse direction.

For the purposes of this project's design, diodes will be used to protect circuit components in switching circuits. For example, in the electromagnetic locking circuit, the main switching component will be either a relay switch or a power MOSFET device. When the switch is active and the magnet is on, the circuit is complete and power flows through the magnet, completing the circuit through the switching device and connecting to ground. However, when the switch is opened, the DC voltage from the ACDC converter will still be connected to the drain of the transistor, which can ultimately create a voltage spike in the MOSFET.

To solve this problem, a "flyback" diode can be placed parallel to the magnet in order to dissipate the excess energy seen at the negative terminal of the magnet. In addition to being applied in this circuit, these "flyback diodes" will be applied to our vibration motors for the same reason: to save our switches from experiencing high voltage spikes and frying the switching MOSFET devices.

3.11 Voltage Regulators

Voltage regulators are an essential component of many electrical powering circuits. They provide the circuit with predictable and fixed voltage outputs, regardless of the input voltage. One problem proposed by our circuit design with the power of our remote vibration chair module is its ability to provide a constant charge: fully charged batteries can hold a higher charge than what they are currently rated for, and as a battery

discharges, its voltage level can drop below its advertised rating. In addition to this, our system requires components to be charged at and below the supplied voltage: for example the Vibration motors to be used will be running on 12V DC, while the weight sensors, microcontroller and communication module run on low voltage, usually between 3-5V DC. Since our system will be running on a completely DC source, DC-DC voltage regulators will be utilized, not only to stabilize the initial DC flow, but to step down voltage levels to usable ranges for our other devices. This section will go into detail describing different types of voltage regulators and how they function and conclude with a decision on which regulators will be best used for our project.

3.11.1 Linear Voltage Regulators

Linear voltage regulators essentially function as step down converters, decreasing the input voltage through a resistive feedback loop. To achieve this, either a BJT or MOSFET is implemented alongside an active high gain amplifier. The linear voltage regulator works to maintain a constant output voltage by constantly comparing the input and output voltage of the regulation system. These types of circuits are very cheap to manufacture, are simple in design, quick to change voltage to the desired level and have little noise. Some disadvantages to this type of regulator are that it produces a great amount of heat in comparison to its counterparts, rendering it somewhat inefficient. Linear regulators can be split into two different categories based on how the load is connected: Shunt and Series regulators.

3.11.1.1 Series Voltage Regulator

The load in a series voltage regulator is placed in series with the load. This is typically the most common approach for providing voltage regulation from a linear supply. The controllable element of the circuit changes resistance, therefore changing the output voltage on the element. When the voltage is affected, the output voltage on the load is changed as well, according to what the controllable element alters while the input voltage remains the same. Figure 13 describes a simple block diagram relating the components together. In terms of different types of series voltage regulators, there are three distinct types simple enough for this project design: the Standard Regulator, the Low Dropout Regulator (LDO), and the Quasi LDO Regulator.

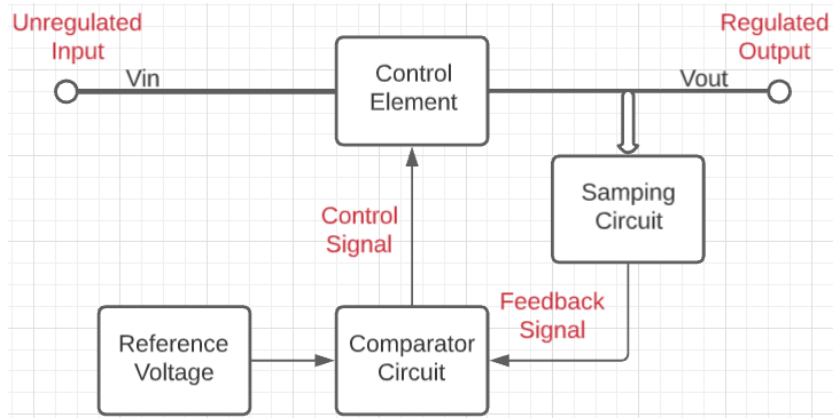

Figure 13. Sample of a Series Linear Voltage Regulator

3.11.1.1.1 Standard Voltage Regulator

The Standard Voltage Regulator, also known as the “Darlington Regulator”, uses a variety of configured NPN transistors to create a standard output voltage. The type of transistor used in this circuit requires a minimum voltage to operate, given by the equation:

$$V_D(\min) = 2V_{BE} + V_{CE}$$

To ensure proper functionality of the circuit, the minimum input voltage of the circuit must be somewhere between 2.5-3V. The drop out voltage of this circuit configuration tends to be somewhere around 1.5-2.2V for linear voltage regulation, and voltage experienced across the regulated circuit tends to be around 3V. Compared to the other types of circuits, this one is best suited for AC power applications. In addition, this type of circuit tends to be best applied when the voltage difference between input in output is above 3V, and the ground pin current of this regulator is the lowest of the three types.

3.11.1.1.2 Low Drop-Out Regulator

Compared to the Standard Voltage Regulator, the LDO regulator only requires one single PNP transistor. The minimum voltage drop required for this LDO regulator is just the voltage across the PNP transistor, given by the equation:

$$V_D(\min) = V_{CE}$$

The maximum voltage across the regulator is typically between 0.6-0.8V, depending on operation (typical versus max current ranges). For this low dropout voltage value, this tends to be the best out of the three series regulators mentioned. This type of resonator tends to be popular in battery-powered systems due to the fact that it can operate with high efficiency and maximize the available input voltage. The ground pin current of this

regulator is the highest of the three types since it is typically equal to the load current divided by the gain of the single PNP transistor.

LDO regulators also tend to be used in low voltage applications (much like that of this project). Using the following equation in accordance with the input voltage, output voltage, quiescent current and output current, the efficiency of the LDO regulator can be calculated:

$$Efficiency = \frac{I_o V_o}{(I_o + I_Q) V_i} \times 100$$

3.11.1.1.3 Quasi Low Drop-Out Regulator

Somewhere in the middle between the three different types of regulators is the Quasi LDO Regulator. This circuit uses a combination of both an NPN and PNP transistor as the passing device. The minimum voltage required for this regulator to maintain regulation is provided by the equation:

$$V_D(min) = V_{BE} + V_{CE}$$

The dropout voltage is typically specified to be around 1.5V.

3.11.1.2 Shunt Voltage Regulator

Shunt regulators work by providing a path from the supply voltage to ground through some sort of variable resistance. Current is diverted from the load, making it less efficient than the typical series regulator. It is much simpler, typically consisting of a voltage-reference diode. The most common type of shunt regulator includes the use of a zener diode, which is parallel to the output of the circuit. A resistor placed in series with the diode drops the voltage of the system, and the zener diode keeps the voltage constant even through varying current. This type of circuit typically does not have feedback, but a feedback loop can be added in to ensure that the required output voltage is maintained.

Although linear regulators are cheap, easy and fairly simple, they tend to be extremely inefficient. The problem with a linear regulator is that when voltage is stepped down, the remaining amount is burned off as heat. At times, the typical linear regulator can burn off more energy than what ends up being delivered to the rest of the device, with efficiencies standard around 40%, sometimes reaching down to 14%. More energy dissipated can also mean shorter battery life for the entire system as a whole.

3.11.2 Switching Voltage Regulator

Another type of voltage regulator is the switching regulator. In simple terms, this regulator utilizes a controller and an electrical switch to take small portions of input power and convert them to the output. This process is much more efficient, with switching regulators being able to run at a higher typical 85% efficiency. These types of regulators are used for applications such as mobile phones, computers, robots and cameras. These types of regulators also have the ability to both step up and step down voltage, a characteristic not shared by the linear voltage regulator. Although these are a better choice for creating a more efficient system, they tend to be much more complex.

3.11.2.1 Buck & Boost Voltage Regulators

Buck and Boost converters are two different types of switching regulators, one for stepping voltage up (boost) and one for stepping voltage down (buck). Both are typically made of the same materials, just arranged in different fashions: both typically consist of some type of switching mechanism (some times MOSFETS or thyristors), a diode, an inductor and a capacitor.

A general Buck converter is shown in Figure 14. Both the transistor and diode of the system work as switches, and the orientation of the inductor in series and capacitor in parallel work as a lowpass filter. When working together, the voltage is decreased to a desired amount, expressed as rapid voltage ripples as given by the overall switching system.

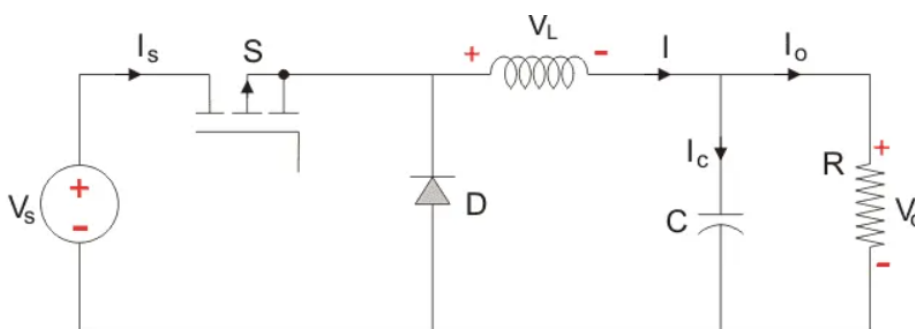

Figure 14. Buck Voltage Switching Regulator

(approved by electrical4u.com,

<https://www.electrical4u.com/buck-converter-step-down-chopper/>)

Figure 15 shows a simple schematic of a Boost regulator. As previously stated, the boost regulator contains the same basic elements as the buck regulator, but in a slightly different orientation. Here, the MOSFET and diode still operate as the switches of the system, but a larger voltage can be experienced over the capacitor, and therefore over the load.

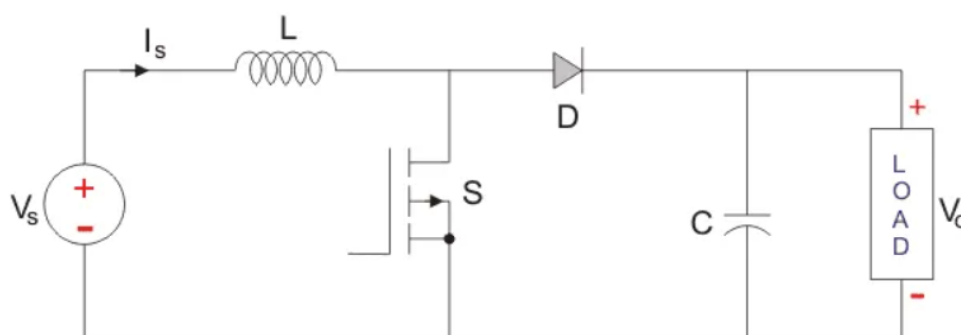

Figure 15. Boost Voltage Switching Regulator

(approved by electrical4u.com, <https://www.electrical4u.com/boost-converter-step-up-chopper/>)

3.11.3 Voltage Regulator Chart Comparisons

This section compares a variety of voltage regulators on the market in order to find some for the purpose of this project. In order for our vibration chair module to work, we require one voltage regulator to produce 12V DC-DC in order to provide a stable voltage value to our motors, as well as a regulator to produce 5V DC to power our microcontroller board. Some features to make this comparison include the minimum and maximum input voltage, rated output fixed output voltage, output current, price and type. Table 7 compares all of these values in order to decide on a single part to use.

For the purpose of this project, we will be utilizing the WEBench software, which will provide premade regulator circuits that offer high efficiency regulation. Because using some of the regulators mentioned in table XX result in highly inefficient regulation, this application is vital to ensuring the efficiency of our system.

Voltage Regulator	TPSM846 24MOLR	LM7805MP/ NOPB	TPS40210	Amazon 12V regulator	TLV62090R GTR
Input Voltage (V) (min)	4.5	7.5	4.5	8	2.5
Input Voltage (V) (max)	17	35	52	40	5.5
Output Voltage (V) (fixed)	3.3	3	12	12	3.3
Output	6 max	1	N/A	3	3

Current (A)					
Price \$ (full circuit estimate)	\$5.35	\$2.77	N/A	\$16.98	\$1.31
BOM Count (complete circuit)	8	3	24 (some "custom")	1 (premade)	9
Manufacturer	Texas Instruments	Texas Instruments	Texas instruments	HOMELYLIFE	Texas instruments
Type or regulator	Buck	Linear	Boost	Step Up	Buck
Efficiency	92%	low	91.8%	96%	94.4%

Table 7. Regulator Comparison Table

For the purposes of this project, as previously stated, a 12V regulator, a 12V-3.3V regulator and a 5V-3.3V regulator will be considered for implementation in this project. The three being chosen for this project are the TPSM84624MOLR, TLV62090RGTR and Amazon 12V regulators. All of these regulators propose high-efficiency functions with a relatively low BOM count, although their price tends to be higher than their counterparts. The LM7805MP/NOPB, although low in price and BOM count, proposes a fairly inefficient regulation system, which weakens the functioning of our project. On the other end of the spectrum, the TPS40210, much like other 12V regulators provided by the WEBench software, includes circuit schematics full of large BOMs and custom parts, something that we do not have adequate access to. Therefore, the 12V Amazon regulator would be the best option for the learning scope of this project. The TLV62090RGTR regulation circuit has a low BOM count, low cost and high efficiency. This regulation circuit will be implemented twice: once for the maglock microcontroller, and again for our chair module microcontroller, to regulate power for microcontroller usage during programming applications.

4.0 Standards

For our project to be able to function properly and safely, certain standards must be met. The following section goes over standards related to a variety of subjects, such as standardized electrical housings for environmental protection, power supply standards for correct operation and security standards for keeping data private. Organizations that

provide the standards to be used in electrical, mechanical and computer engineering include ANSI, IEEE and IEC among others.

4.1 Standards of Electricity

When reflecting on an electro-mechanical system that is meant for consumer usage, one key factor must be considered: the separation of electrical components from water. Not only does the introduction of water into an electrical system pose possible damage to components, but it also creates safety concerns, for the compounds in water can easily conduct electricity, harming anybody in contact with it. Although this project does not concern itself with the elements of the outdoor realm, certain situations must be accounted for in the typical office setup to ensure safety. Some of these situations include a spilled drink on the desk onto the lockbox and perspiration from the users posterior onto the vibration chair module. When these events occur, not only does the system need to have its primary components protected, but protruding elements such as wiring and (possible) antennae must be protected as well.

In the event electrical problems, such as power surges or some type of user misuse, safety components such as relays may be implemented. A relay is a component that has the ability to clock the system when certain thresholds are reached, therefore protecting the rest of the circuit. Instead of the entire circuit being blown, possibly costing hundreds of dollars, only the blown relay would need to be replaced. This results in easy system repair later down the line, as well as during full system testing periods.

The standard article ANSI/IEC 60529-2004, published by the IEC, contains classifications of different degrees for two different conditions: protection of equipment against foreign objects (typically solid things) and protection of equipment from exposure to water. These degrees of protection are used to ensure the safety of equipment in a variety of different environments.

To understand the degree to which each type of item is protected, the IP Code is utilized, which is a method of classification showing the protection of each condition. Essentially, the standard ranking can be simplified down into the coding system mentioned in the Tables 8, 9 and 10 below.

1st IP Protection Ranking: Solid Foreign Objects		
Rank	Protection Specification	General Protection Association Example

0	No protection against any type of solid	No Protection
1	Objects Bigger than 50mm in diameter	hands/ large tools
2	Objects Bigger than 12.5mm in diameter	fingers/ large tools
3	Objects Bigger than 2.5mm in diameter	Small tools/ wires
4	Objects Bigger than 1mm in diameter	wires
5	Sufficient Protection from entry of dust that could interfere with equipment	Very little dust can enter
6	Complete dust protection	Semiconductor fabrication lab level dust protection

Table 8. Solid Foreign Body IP Code Classification Table

2nd IP Protection Ranking: Liquid Penetration Classification		
Rank	Protection Specification	General Protection Association Example
0	No Protection	No Protection
1	Protected against vertical water drops	Electrical component under a protective sheet
2	Protected against vertical drops when at a 15 degree tilt	Light protection in a misty situation
3	Protection against water spraying at 60 degrees on either side	A protective sheet covering most of the upper portion of the device, much like a plastic shielding
4	Protection against water sprayed at any angle	Limited ingress of water
5	Protection of low pressure jets of water coming from all directions	Limited ingress of water
6	Protection against temporary flooding of water	Limited ingress of water (primarily used for on deck shipping purposes)

7	Protected against full immersion between 15 cm and 1 m	Typical advertising of something being “waterproof”, like a smartphone.
8	Protection against long periods of immersion under pressure	Submersible electronic devices such as underwater submarines

Table 9. Liquid Immersion IP Code Classification Table

In addition to these two IP codes for determining the effectiveness of enclosures, a third code number classification is also sometimes used, but is not part of the IEC 60529 official standard. This third classification is involved with protection against mechanical impacts. This code may be explored for the vibration chair module, given that someone will be sitting on it. The impact of the person’s bottom on the module should be taken into consideration, for the electronics of our system may be directly below the user in question. The following table explores this classification.

3rd IP Protection Ranking: Protection Against Mechanical Impacts		
Rank	Protection Specification	General Protection Association Example
0	No Protection	No Protection
1	Protection against impact of 0.225 joule	150g weight falling from 15cm
2	Protection against impact of 0.375 joule	250g weight falling from 15cm
3	Protection against 0.5 joule	250g weight falling from 20cm height
4	Protection against 2.0 joule	500g weight falling from 40cm height
5	Protection against 6.0 joule	1.5kg weight falling from 40cm height
6	Protection against 20.0 joule	5kg weight falling from 40cm height

Table 10. Mechanical Impacts IP Code Classification Table

Our enclosure will be striving to hold a classification of at least **IP343**, which means the electrical enclosures should have protection for small tools and wires, a water protection that allows for small sprays all around the enclosures, and impact protection of up to 0.5 joules.

4.2 PCB Standards

When creating our own printed circuit board (PCB), we will need to keep in mind some related standards. The IPC-2221A “Generic Standard on Printed Board Design” was created to provide information on the basic requirements for organic printed board design. The standard also addresses concerns regarding mounting and interconnecting electronic structures. IPC breaks down three classes of electronics/PCBs.

- **Class 1 - General Electronic Product**

The first class includes the products with the lowest requirements and longevity is not the top priority. These products are typically high demand items at low prices, therefore quality is not the main concern. This category refers to common electronic products such as toys or smartphones.

- **Class 2 - Dedicated Service Electronic Products**

The second class includes products with higher performance capabilities and an extended life cycle. The guidelines are not strict but an added benefit. There are no consequences to having these products fail, but they are expected to last for a while. This category refers to larger products with longer lifespans such as televisions, air conditioners and tablets.

- **Class 3 - High-Reliability Electronic Products**

The third class enforces strict guidelines on their products as they are used in important situations. This class is designed for medical and military equipment. There is no room for error or mishaps in these scenarios. These are the high performance, reliable electronics that are produced no matter the cost.

The classifications above are also relevant to IPC J-STD-001G “Requirements for Soldered Electrical and Electronic Assemblies”. This standard covers requirements of materials, processes and acceptability.

4.2.1 PCB Design Software Selection

In order for our team to have a functional, working PCB board, it is important to select a software to design the board on. This section compares different PCB design softwares

for the purpose of finding one our team can utilize. Table 11 shows this comparison on a variety of different aspects.

Design Software	Cost	Constraints	Layers	Miscellaneous
Eagle Standard	\$100/yr	160cm ² 99 schematic sheets	4	Schematic sheets, layout, autorouter
Eagle Free	\$0	80cm ² 2 schematic sheets	2	Schematic sheets, layout, autorouter
Easy EDA	\$0	N/A	N/A	Cloud-based, schematic, sheets, layout, team collaboration

Table 11. PCB Software Decision Table

Looking at the comparisons, Easy EDA may be the best option for designing PCBs. Due to the fact that it is free, and has a cloud-based team collaboration setup, this would be optimal for remote, team adjustments on our PCB designs as changes occur. Other softwares, such as EagleCAD, may still be used, however, because as it stands, the status our group has as students permits a free trial of Eagle to be used.

4.2.2 PCB Manufacturer Selection

After selecting the design software for creating our PCB, we must find a manufacturer able to fabricate our PCB. In Table 12, a variety of PCB manufacturers are compared, with an ultimate decision on which company may be the best option.

Manufacturer	Associated Software?	PCB Cost	Shipping Cost	Total Cost	Build Time	Shipping Time
JLCPBC	EasyEDA	\$2 (deal)	\$16.81	\$18.81	1-2 days	15-20 days
NextPCB	N/A	\$4.50 (deal)	\$22.37	\$26.87	24 Hours	3-5 days
OSHPark	N/A	\$5/in ²	N/A	\$5/in ²	N/A	9-12 business

						days
PCBWay	N/A	\$66/5PCB	\$25	\$91	24 Hours	3-7 days

Table 12. PCB Manufacturer Decision Table

For the purposes of this project, we believe that JLCPCB may be the best option, especially since it has some sort of known compatibility with EasyEDA, the PCB development software of our choice. Although it is seen to be one of the longest shipping times, it is also the lost cost effective out of the bunch. If something faster were to be requested in the case of a fabrication emergency, NextPCB will be taken into consideration.

4.3 Power Supply Standards

This section discusses standards relating to power supplies. It is broken down into two main subsections to describe standards for battery packs and USB power supplies.

4.3.1 Battery Pack Standards

Two IEEE standards relating to implementing battery packs are presented below along with a brief description of each.

4.3.1.1 IEEE standard 1625-2004

One primary concern with this project is the implementation of a battery pack. IEEE standard 1625-2004 titled “IEEE Standard for Rechargeable Batteries for Portable Computing” must be reviewed. This standard provides guidelines for design analysis for qualification, quality and reliability of rechargeable battery systems in terms of portable computing devices, in addition to their management and control systems with end-user notification. This gives insight into the implementation of a battery management system, as well as possible proper integration of an SOC estimator for our vibration chair module. A few topics discussed within this standard include overheating, overvoltage, overcurrent, overcharge, over-discharge, mechanical stress and connector/terminal precautions among others.

In addition to these precautions set for the actual battery pack, standards for the host device using the battery pack must also be taken into consideration. Primarily with these specifications, overcurrent and overvoltage are of main concern, requiring the system in question to have some sort of measurement system in place to determine if the input current/voltage is allowed.

Low voltage modes are also discussed within this standard, which are necessary when considering one of the goals of the battery system: a life-span of around 8 hours to represent the typical work day. Other specifications are discussed in relation to altered modes of the host system, including warning notifications when communication between the battery and the host fails, as well as precautions related to the reset of the system in case of malfunctions. Besides these points, other details about testing the battery packs, charging algorithms, failure mode analyses and other characteristics are also discussed.

4.3.1.2 IEEE Standard 1635-2018

This standard focuses on the ventilation and thermal management systems of stationary batteries. If a battery were to be implemented in either the smart lock system or vibration module, it is important for there to be ventilation and thermal management so that the battery itself is not damaged, and the user is not burned or harmed in any way while using the concentrating apparatus. This is vital especially for the vibration chair module, which will be in direct contact with the user.

Looking through this standard, most of the applications apply to higher voltage stationary batteries which tend to stay put from design, rather than being semi-portable, which our apparatus will be (we should be able to set up and dismantle the chair module and lock box from the host computer if needed to be transferred to another location). However, the HVAC system ideas should still be taken into consideration in order to optimize performance and longevity of our product. For example, when looking at the chair module, having one section of the seat facing open air is important for cooling the battery pack, in addition to allowing for easy replacement if need be.

As stated in this standard, deviations from the normal operation conditions (temperature, dust, humidity, access to flammable materials) can disrupt the system abruptly and must be accounted for. In this case, it may be beneficial to implement our own cooling system, consisting of something like a fan facing the battery and other electronics. However, considering how little power this system has the potential of drawing, it may not be necessary. Further design and testing will need to be done in order to determine the correct approach.

4.3.2 USB Standards

As previously stated in the research and development section of this article to a greater extent, USB cords come in a variety of shapes, sizes, pin counts and speeds. A USB cable will need to be implemented in order for our microcontroller to receive information and power fast from the host computer. Following the guidelines previously provided about choosing the correct USB is crucial in order to create a fully functioning system.

4.4 Legal Standards

As our product is something that someone could potentially buy for use in their own home, we need to consider the fact that a person may not be familiar with how to use or maintain the product on their own. The IEEE/IEC 82079-1-2019 is titled “International Standard for Preparation of information for use (instructions for use) of products - Part 1: Principles and general requirements” This standard discusses the general requirements that a producer needs to supply to consumers with their product to help them understand how to properly use the product. The consumer that will act as the user of the product needs to understand how to properly install, use, and maintain the product to prevent them from either damaging the product or injuring themselves in any way. If a person were to attempt to use the Concen-training module without any form of instruction on how to properly use the product, they could potentially break the product or even hurt themselves. For example, if the user does not carefully handle one of the microcontrollers or associated PCBs, there is potential for them to do damage to the product to not allow it to function as intended. Also, since our chair module is intended to be placed on any chair, they may not secure it to the chair in use, leading it to slide off the chair and they could get injured by this action. In either of these cases, the inventor(s) of the product are held responsible as they did not include proper instructions for use of their product.

4.5 Security Standards

The idea for Concen-training came from the transitions to online and remote learning over the past year. With the virtual classroom experience, students are finding themselves using their personal computers to attend their classes from home. The implications of using these personal computers as well as webcams in their home environment means that there is potential for security breaches with personal information stored on the students’ computers and what can be seen through the webcam in the same space as the student. As teachers and school systems have had to adjust to this new learning style, new standards have to be developed to help prevent data and security breaches like these from occurring. Currently, the IEEE standard “P7004.1 - Recommended Practices for Virtual Classroom Security, Privacy, and Data Governance” is being developed to help outline the best practices that are up to the requirements of the IEEE standard “P7004: Standard for Child and Student Data Governance” when it comes to how to best run and monitor an online classroom environment. As this standard is still under development, it will be something that we will have to consider all possible updates to going forward to make sure we are meeting all possible requirements. Since our project will utilize a camera for the eye tracking system, we need to make sure that we will not be infringing upon anyone’s personal information while they are using our product.

Because our base goals do not require us to keep any camera information or track data, the applicable standards for data security are fewer in number. However, if we reach our stretch goals of recording user data and making that available to the people and/or institutions using the software we will need to locate any available standards for handling that camera or eye movement information. As eye tracking is a relatively new field especially in this application, there may not be internationally recognized standards for eye tracking specifically, but our team will do our best to find standards for similar technology that may overlap with the eye tracking project and draw inferences from those standards in order to maintain user security and privacy in the best way possible.

4.6 Programming Software Standards

This section includes a variety of standards related to programming. Listed below is a selection of standards with brief descriptions, ranging from testing techniques, measurement techniques and information development techniques.

4.6.1 IEEE 29114-4

The IEEE 29114-4 “Software and Systems Engineering - Software Testing - Part 4: Test Techniques” standard talks about techniques used in testing software and defines test design techniques for multiple types of testing including specification-based testing, structure-based testing and experience-based testing. What those are and how to handle them are detailed in this document.

When finalizing our software and our system in general we will need to test and understanding the industry standards for testing will be helpful in making sure our tests are thorough and reliable. Our team will most likely take advantage of Structure-based testing as described in the document that relies on testing based on the way the source code is structured. Another testing method described in the document that would be advantageous to our team is experience-based testing that involves using the testers own knowledge to compare with the actual results and determine how they compare. This is something our team would have used without having read about it, i.e. comparing our specifications for response time to actual response time, but having the standards document allows us to describe the results in a professional way and make sure the experience testing follows the most secure methods for unbiased results.

4.6.2 IEEE 15939

The IEEE 15939 “Systems and Software Engineering - Measurement Process” standard discusses a common process and framework for measuring software and systems as well as defines said process and any associated terms from an engineering perspective.

These processes can be applied to most projects at any point in the life cycle to aid in each step.

Although this standard document does not specifically identify the way to measure the exact things our project will entail, it does provide general guidelines for choosing measurement processes that are reliable for the things that need to be measured within our software. Ultimately measurement is an integral part of testing and demonstrating a working product. Being able to quantify how well something works via measurement is key and sometimes figuring out what to measure and how to measure that thing can be a challenge so this standard outlines procedures to make those decisions for general projects.

4.6.3 IEEE 26515-2018 Systems and Software Engineering - Developing information for users in an agile environment

This standard discusses requirements and guidance when it comes to information developers working within an agile environment. It provides appropriate processes for software projects using an agile methodology to create information well.

These standards generally help users of the Agile software development method make sure that within sprints and other stages of the development process, information is being produced in a clear method. Because the Agile method is based on short sprints and frequent communication between developers and the user, a lot of information is created and passed from developer to user and between developers and without any standards to follow the quality of the information developed can become sloppy or rushed. So this document provides general guidance for providing relevant information in meetings in a way that can be understood during the development process. Since our team is using a version of the Agile software development method as well we are able to take advantage of these guidelines and benefit from a more clear and informed experience when it comes to our user stories and sprint meetings.

4.7 Wireless Communication Standards

The IEEE 802.11-2020 standard, "IEEE Standard for Information Technology -- Telecommunications and Information Exchange Between Systems - Local and Metropolitan Area Networks -- Specific Requirements - Part 11: Wireless Lan Medium Access Control (MAC) and Physical Layer (PHY) Specifications", is for wireless local area networks (WLAN) and this is the most recently updated version of this standard. This standard provides wireless connectivity within a local area for fixed, portable and moving stations. It also offers a means of standardizing access to frequency bands for the purpose of local area communication. WLAN, also more commonly referred to as

WiFi, operates on the 2.4 GHz and 5 GHz Industrial, Science and Medical (ISM) frequency bands and comes in different variations like IEEE 802.11a/b/g/n. WLAN is heavily utilized in the consumer market where laptops and smartphones support one or more of these variations.

The IEEE 802.15.1 standard, “IEEE Standard for Telecommunications and Information Exchange Between Systems - LAN/MAN - Specific Requirements - Part 15: Wireless Medium Access Control (MAC) and Physical Layer (PHY) Specifications for Wireless Personal Area Networks (WPANs)”, deals with Bluetooth. The standard is an adaptation of the Bluetooth specifications medium access control (MAC) and physical layer (PHY). This standard was developed in order to define PHY and MAC specifications for wireless connectivity for devices within a Personal Operating Space (POS). It was designed for small, low power devices.

The IEEE 802.15.4 standard, “IEEE Standard for Low-Rate Wireless Networks”, dives deeper into the previous standard, IEEE 802.15.1. It includes PHY and MAC sublayer specifications for “low-data-rate wireless connectivity with fixed, portable and moving pieces with no battery or very limited battery consumption requirements”. PHYs are defined to work in varying locations and on a variety of frequency bands.

4.8 Electromagnetic Locking Standards

When dealing with electromagnetic devices, the safety of individuals and their integrity of other pieces of equipment within the system come into question. The following standards go more into depth about user safety when exposed to electromagnetic waves, as well as precautions to be taken to hold the integrity of devices and their abilities to send and receive signals.

4.8.1 IEEE Standard C95.1-2019

This standard is titled as “Standard for Safety Levels with respect to Human Exposure to Electric, Magnetic and Electromagnetic Fields, 0 Hz to 300 GHz”. The purpose of this standard is to provide science-based exposure criteria in order to mitigate adverse health effects related to exposure to different types of physical fields. The article uses measurement methods such as dosimetric reference limits (DRLs) and exposure reference levels (ERLs). DRLs are measured by electric field strength, specific absorption rate (SAR) and power density, while ERLs are determined by more external factors such as limits on currents, contact voltages and field strengths among other things to keep DRLs to a minimum.

In relation to this project, the primary piece of equipment to be concerned with would be the Electromagnetic Lock, given that it sits on the user's desk, not too far away from their person depending on the size of the desk. The types of electromagnetic switches in question for the scope of this project are relatively weak (the strongest one being considered rated only for about 60kg, most operating on DC power for simplicity. Therefore, not much risk has been identified with someone coming in contact with this type of magnet.

This standard also includes tables of exposure limits for different parts of the body. For example, exposure limits to the brain would be much smaller in allowance than exposure to a person's arm or leg. Since our locking apparatus would primarily only encounter close exposure to the user's arms and possibly legs, these numbers would be referenced

4.8.2 MIL-STD 464

Interference in an electromechanical system as induced from an electromagnetic field can also pose concerns within a system, the military standard MIL-STD 464 explores this topic on a greater scale, describing electromagnetic environmental effects (E3) interface requirements and verification criteria for a multitude of military grade equipments, such as oceanic vessels, space ships and other related ground systems.

Although our concentrating apparatus will not be crafted on such a scale as the aforementioned systems, reading this standard gives insight into the possibility of electromagnetic interference into our system. Problems can occur if our locking magnet is placed too close to our microcontroller system, or even if the locking mechanism is placed too close to the smartphone being placed in the box. This constraint may require the lock box to be larger or taller than intended in order to uphold the integrity of other pieces of electrical equipment, providing more of a buffer distance between the elements in question.

5.0 Hardware

This section is dedicated to the hardware design aspect of our product. The overall hardware summary will be presented along with supplemental sketches of different design elements. Specific parts will be identified in this section. Product images and schematics may be included in addition to the descriptions to aid in understanding our hardware implementation.

5.1 Hardware Design Summary

The hardware design consists of a few key elements. The user will allow access to their laptop's webcam for the eye tracking software to work. This software will relay information via bluetooth to the microcontroller in the user's chair. From there the motors will be notified to turn the vibration mechanism on or off based on the eye tracking input. The hardware will either be attached to the back of the chair or inside the seat cushion. By attaching the mechanism to the back of the chair, this could be more easily implemented by consumers to their existing desk chairs. There will also be a lock box for the user to put their phone in while they are studying to be free of distractions. This box will lock for a desired amount of time and be unlocked as a reward for continued focus. It will also have an emergency release system in case of emergencies.

5.2 Prototype Sketches

This section of the document includes a series of preliminary design sketches for the overall functioning of our Concen-training apparatus. The first of which is an overall ecosystem sketch, exhibiting how each of the modules would theoretically be laid out, followed by a series of more in-depth sketches describing what each individual module will contain, as well as general functions.

5.2.1 Overall Apparatus

As previously stated, our software will be utilizing the webcam already implemented in the user's laptop/computer. After a period of inactivity, the sensor sends a message to the communication module, which then either waits for another signal cancelling that inactivity (eyes return to the screen and the sensors record it), or a period of time passes past inactivity and focus stimulation must be applied (the vibration jolt). To experience the fastest communication between sensor and communication module, the communication module will be linked via USB connection to the computer in use.

Once a vibration signal is needed according to the sensor's message, a bluetooth message on the communication device will be triggered, sending a signal to the vibrating module on the chair/stimulation apparatus (which should be physically separate from the communication device for ease of setup and streamlined appeal). Once this message is received, a slightly uncomfortable vibration will be triggered on the chair in order to remind the user to maintain eye contact with the material on the screen. The figure below is a pictorial representation of how the product environment shall be portrayed.

In addition to these modules, extra reinforcement and deterrent tools will be utilized. A smart-lockbox will be implemented to hold the user's phone for certain amounts of time (pictured in green). If they have been focusing for a certain period of time, the box will flash green, indicating a small phone break is allowed, and the box will unlock. When

the break is over, the box will flash red, requiring the phone to be placed back in the box.

To ensure that the user is sitting in the chair, there will be a pressure sensor in the cushion of the chair. This ensures that the user is in contact with the chair vibration module, allowing for optimal usage of our focusing system. The prototype sketch of the overall system is shown in Figure 16.

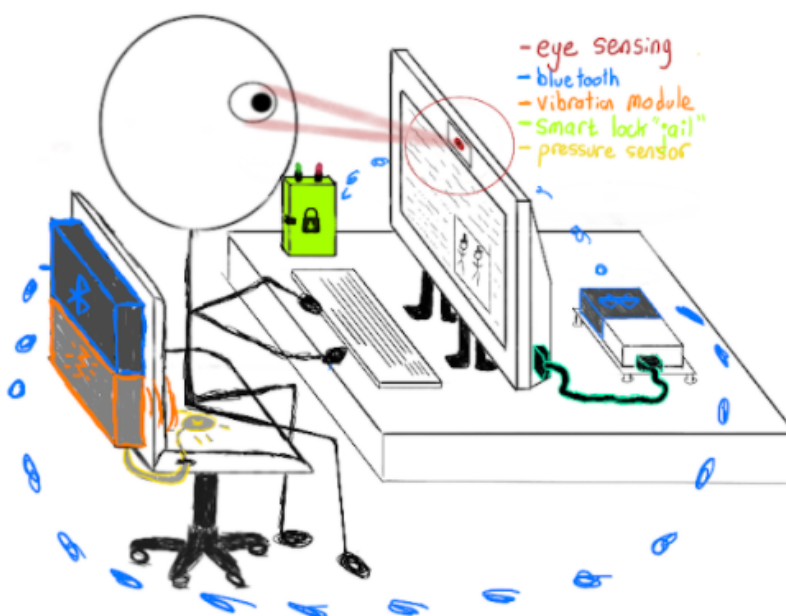

Figure 16. Overall Ecosystem Prototype Sketch

5.2.2 Smart-Locking System Prototype Sketch

With regards to the three previous mentioned locking systems, the one fulfilling the needs of this project is most likely the simple electromagnetic lock. Although there are concerns with residual magnetism, our system will not require strong electromagnets: the “smart lock box” will essentially be a small jail cell to temporarily hold one’s smart possessions in order to prevent distraction from studies.

The setup for our smart locking apparatus will include a small swing door system with magnetic components installed on the frame and handle of the lock box. To reduce the mechanical skill required to fabricate this locking apparatus, our locking system will primarily consist of two locking plates (one on the frame of the door, and one protruding from the door to be lined up exactly with the frame piece). Inside of this lock box will be a small pressure sensor to indicate whether or not the phone or other device is placed inside the lock box accordingly. Located either on the top of the box or another visual location, will be two small LED lights, used to indicate whether or not the lockbox is

unlocked/when the user is allowed to take a smartphone break. Figure 17 is a rough sketch of the smart locking concept design.

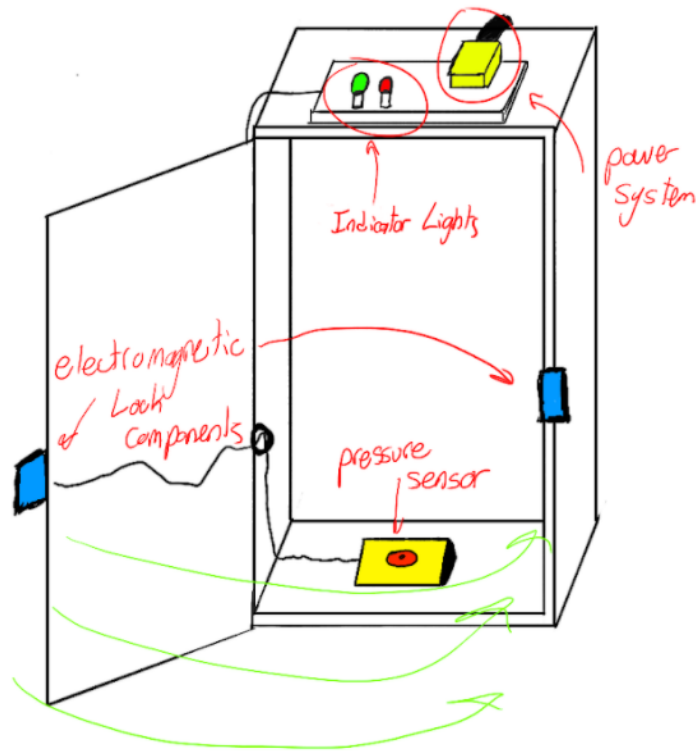

Figure 17. Smart Lock Box System Prototype Sketch

5.2.3 Vibration Chair Module Prototype Sketch

The chair module is one of the most important pieces of our design as this is going to tell the software when the user is sitting in the chair, as well as vibrate when the user has found themselves distracted for too long. Knowing that the chair module needs to house both vibration motors and weight sensors, the structure of the chair module needs space to house these components. Since the user will likely be sitting on the chair for a prolonged period of studying, a cushion will be added to the top of the chair module to offer some comfort to the user. In addition, straps will be added to the structure of the chair module to prevent it from sliding off the chair while a person is using it. Figure 18 shows this prototype sketch.

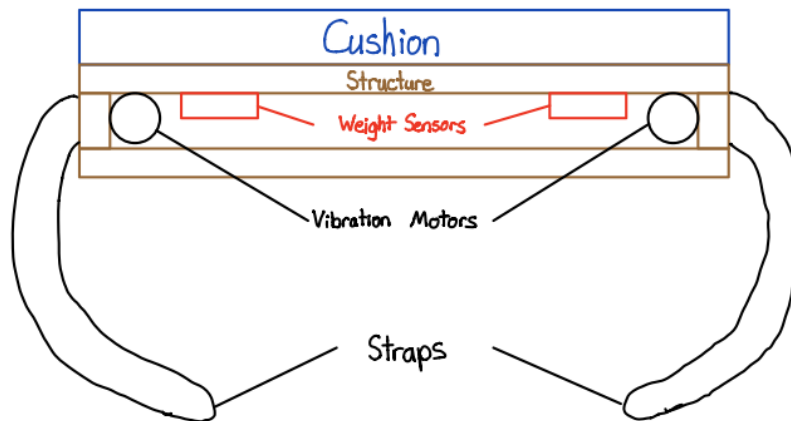

Figure 18. Chair Vibration Module Prototype Sketch

5.3 Hardware Block Diagram

Figure 19 is a block diagram for all hardware aspects of our design. Each block represents an element of our product. They are color coded to show which team member(s) will be responsible for researching and working on which parts. Danny was originally assigned to working on the phone jail, or smart lock box, the mounting apparatus and the motors. Mitch was assigned to working on the power source, weight sensor and vibration mechanism. Yusuf was assigned to working on the eye tracking software and chair. Zoe was assigned to working on the microcontrollers and status light. Yusuf and Zoe will work together on the overall software processing design.

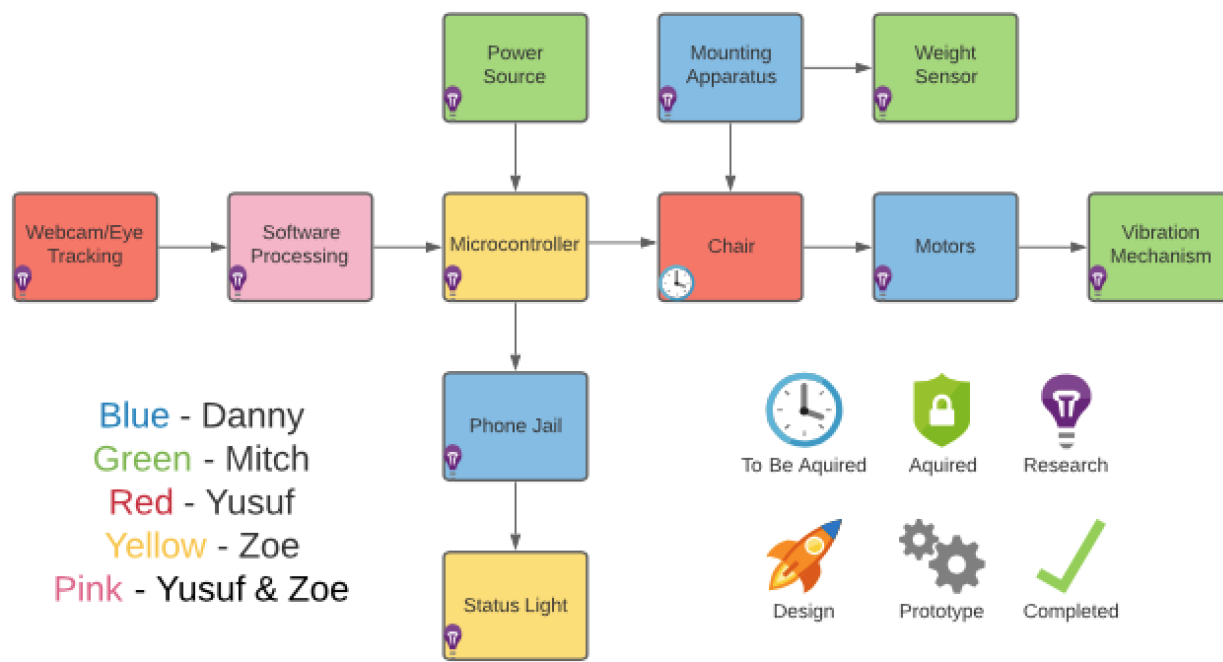

Figure 19. Block Diagram of Hardware Components

5.4 Computational Modules

Two communication modules will be used in our design. The main communication module will be directly connected to the user's laptop/computer and will handle most of the computation. This module will also be connected to the smart lock box to directly control the sensors and mechanics involved with the box. The secondary communication module will be attached to the hardware on the chair. This module will be in control of the vibration motors and the weight sensor in the seat cushion. It will relay information to the main module via wireless communication.

5.4.1 Main Computational Module

For the main communication module, we have decided to use the MSP430FR6989. This device was chosen for its variety of capabilities and how they align with our design. Along with its functionality, this device was already purchased for previous classes which means the money we allocated to this device can go into other areas if need be.

The MSP430FR6989 has a body size of 14 mm x 14 mm. The MSP-EXP430FR6989 LaunchPad Development Kit is an Evaluation Module (EVM) for this MCU. This board includes on-board emulation for programming and debugging. The board includes two buttons, two LEDs and a segmented LCD screen for user interaction. Figure 20 shows the MSP4306989 on the LaunchPad.

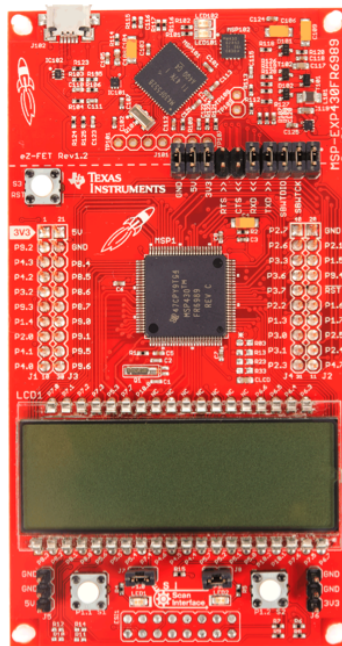

Figure 20. LaunchPad Development Kit (approval pending from TI.com)

The microcontroller will be embedded into our final PCB design but the board will be used for development purposes. The MCU will be directly connected to the user's laptop/computer via a micro USB cable which was provided in the development kit. This is how we will program the board and relay information from the secondary module back to the laptop/computer if necessary. This device will also be directly connected to the lock box and responsible for controlling the electromagnetic lock as well as reading information from the weight sensor in the box. Connections for this module are shown below in Figure 21.

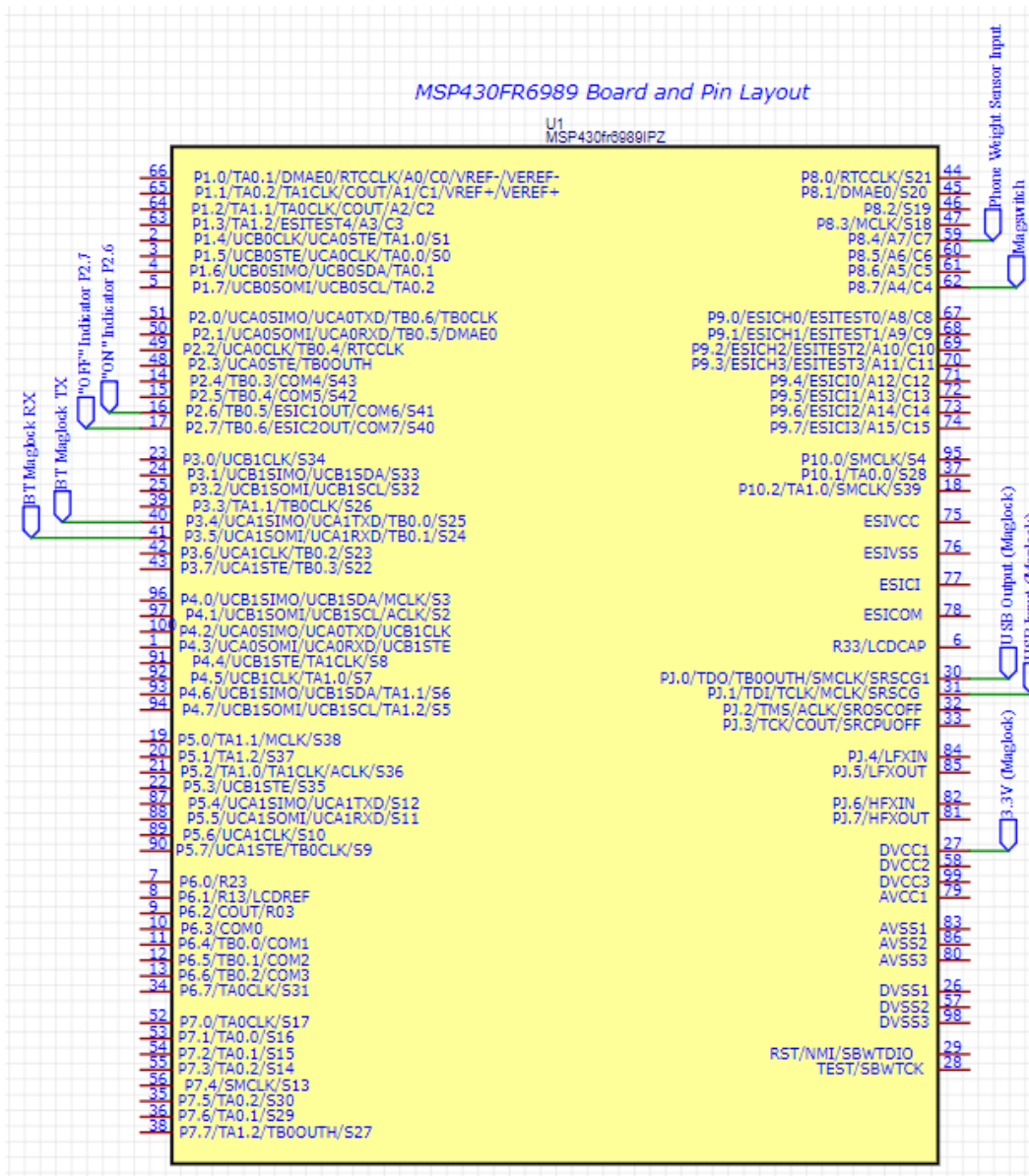

Figure 21. Maglock Microcontroller pin layout

5.4.1.1 Connection to Electromagnetic Lock

To connect the main computational device to the electromagnetic lock, we will need to determine how the lock operates. The I/O pin will most likely be used to connect the electromagnetic lock to the board. When the connected pin gives a certain signal, the lock will know to turn on by activating the power supply, and locking the lock box. Then when the connected pin sends a different signal indicating to unlock, the power supply will be cut off and the lock will release, allowing for the user to remove their phone from the box.

5.4.1.2 Connection to Phone Weight Sensor

To connect the main computational device to the weight sensor inside the phone lock box should be fairly simple. The method being used to create the lock box weight sensor uses velostat and two pieces of a conductive material, in this case copper tape. One piece of the copper tape will be connected to a wire which connects to an analog pin on the board. From this, we should be able to get an input reading to determine when the phone is placed on this surface inside the lock box.

5.4.1.3 Connection to Status Light

To connect the status light to the main computational device, we will need to simply connect two LEDs lights to two separate pins on the board. When the green LED is illuminated, this signals that the user is on a break and can use their phone. When the break is over, the red LED will illuminate signaling that the break is over and for the user to put their phone back in the lock box.

5.4.2 Secondary Computational Module

For the secondary communication, we have chosen to use the MSP430G2553. This device was chosen for its supported communication channels and programming languages among other capabilities. This device was also purchased prior to this project allowing for even more room in our overall budget.

The MSP430G2553 has a body size of 6.5 mm x 6.4 mm. The MSP-430G2ET LaunchPad Development Kit is a development board for this MCU. It has on-board emulation for programming and debugging, one user button and three LEDs. This board also features BoosterPack Plug-in Module pinouts to allow for added capabilities such as wireless communication and displays. Figure 22 shows the MSP430G2553 on the LaunchPad.

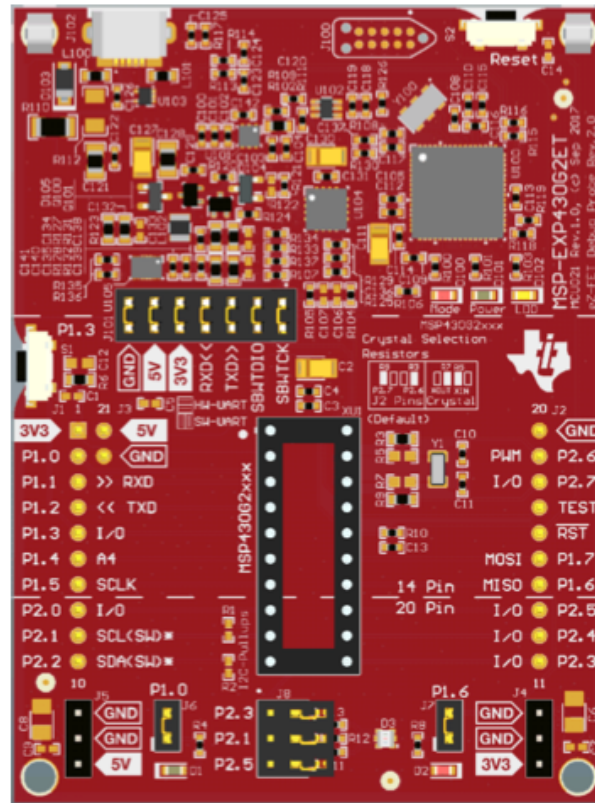

Figure 22. MSP-EXP430G2ET LaunchPad Development Kit
(approval pending from TI.com)

Above is an image of the board with the MSP430G2553 MCU. The board will be used for development purposes as well. This microcontroller will be responsible for handling the hardware on the chair module. It will tell the vibration motors when to turn on and off depending on the signals it receives from the main module. It will also be responsible for relaying the input from the weight sensor on the chair to the main computational module. The weight sensor will connect to an ADC analog input pin on the MCU. The ADC10 module on the MSP430G2553 supports fast 10-bit analog-to-digital conversion by implementing a 10-bit SAR core, sample select control, reference generator and data transfer controller for automatic conversion handling. All of this allows for samples to be converted and stored without CPU intervention. Figure 23 shows the connections made to the MSP430G2553 chip. Vcc is connected to 3.3 V, which also goes to a pin on the mini USB-B port to allow the chip to be programmed. The input and output pins for the USB are connected to P1.6 and P1.7. P1.1 and P1.2 are connected to the transmitting and receiving pins on the HC-05 Bluetooth module. Pins 2.0 to 2.3 are each connected to a vibration motor in the chair. P2.4 is connected to the weight sensor data pin and P2.5 is connected to the weight sensor clockpin.

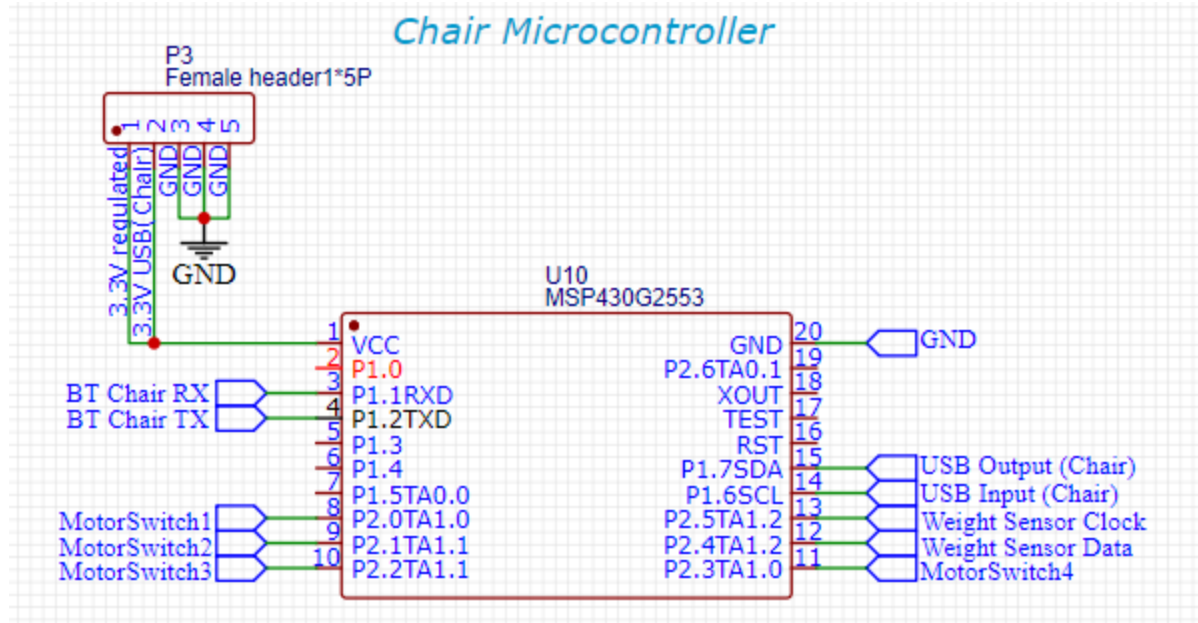

Figure 23. Chair Microcontroller Pin Layout and Powering

5.4.2.1 Connection to Vibration Mechanism

To connect the secondary computational device to the vibration mechanism being used in the chair, we will use a few I/O pins. Depending on how many vibration motors are needed, one pin will be required to connect to the board for each motor.

5.4.2.2 Connection to Chair Weight Sensors

The weight sensor being used in the chair module is different from the one in the lock box, which means we will need to connect this sensor to the microcontroller differently. The four strain gauge load cells will be used to create a full Wheatstone bridge, where the load cells will act as the resistors in the Wheatstone bridge formation. The sensor will connect to the HX711 amplifier which makes the data from the sensor easily readable with the microcontroller. The amplifier will require four pins on the MCU to create the connection. The ground will connect to the ground on the board, the Data (out) and Clock (in) will connect to digital I/O pins, and the Vcc supply will connect to either 3.3 or 5 V on the board. Figure 24 shows the general layout for the connection of our chair weight sensors to the amplifying board, and Figure 25 shows the circuit used when correctly adjusted for the 3.3V input from our regulated power circuit. The circuit built around the HX711 amplifier is a design used in the HX711 AD amplifier module to easily supply voltage to the load cells and take in the data from the load cells to be easily interpreted on a microcontroller. This circuit is available in the datasheet for the HX711 AD amplifier module. The values for the resistors labeled R15 and R16 were chosen using the equation:

$$V_{AVDD} = V_{BG} * \frac{R_{15} * R_{16}}{R_{15}}$$

In the datasheet, V_{BG} is listed as 1.25 V and V_{AVDD} is the voltage to be supplied to the load cells. For this value, we chose to use the same 3.3 V measurement that will be provided to the amplifier module circuit, as it can be any voltage in a range from 2.6 - 5.2 V. Using these values of 3.3 V and 1.25 V, we were able to find that $R_{15} = 1.64 * R_{16}$.

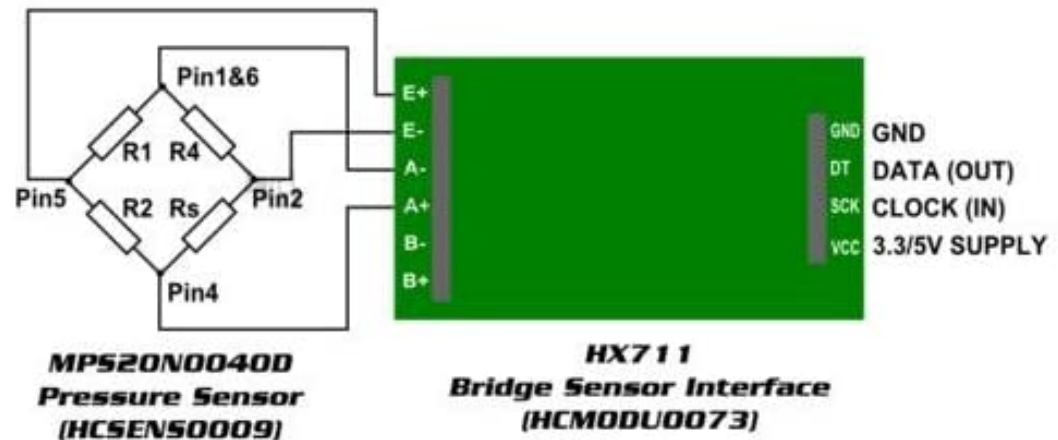

Figure 24. Pins on HX711 Amplifier

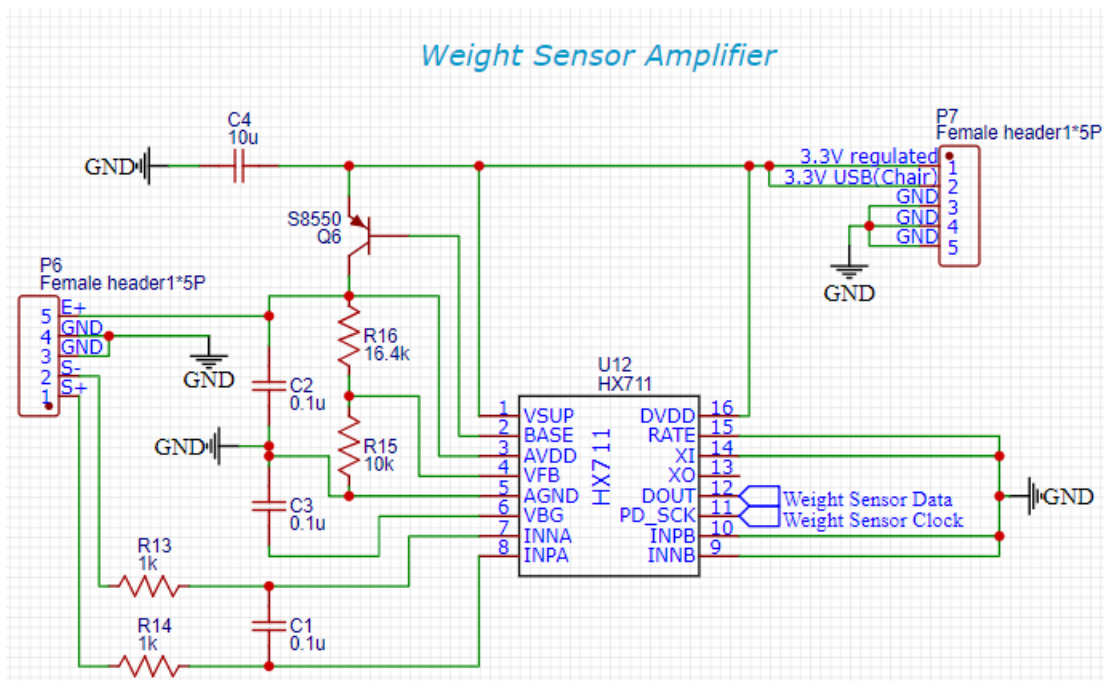

Figure 25. Weight Sensor Amplifying Circuit

5.4.3 Wireless Communication Modules

Both the main and secondary modules will need an additional wireless communication module to gain wireless communication capabilities. Options for this were researched and compared in section 3.4.1. The device decided upon is the HC-05 because of its price and functionality. This device will be utilized for both computational devices as neither have wireless capabilities built in. The size of this device is approximately 12.7 mm x 27 mm. Figure 26 shows the pinout diagram for this module.

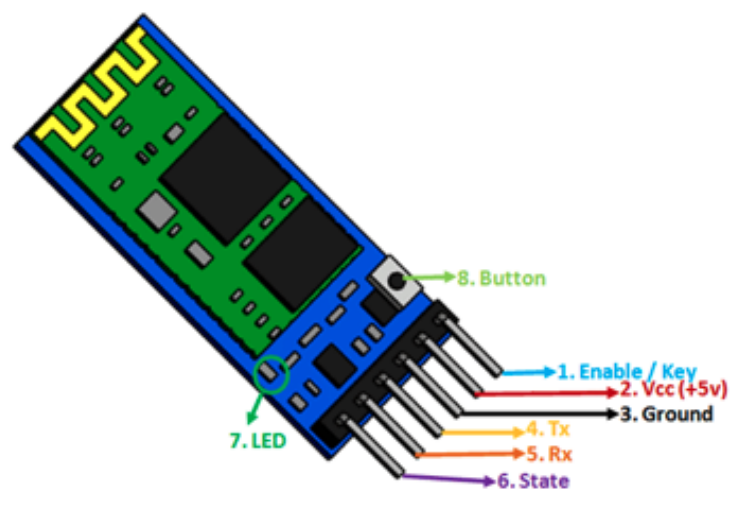

Figure 26. HC-05 Bluetooth Module Pinout (pending approval from components101.com)

To connect this module to our MCU boards should be simple. The ground (GND) pin will be connected to ground. The Vcc (5V or 3.3V) pin will be connected to Vcc on the board. The TX pin will be connected to TXD on the board (P3.4 on the MSP430FR6989 and P1.2 on the MSP430G2553). The RX pin will be connected to RX on the board (P3.5 on the MSP430FR6989 and P1.1 on the MSP430G2553). This is shown in Figure 27 below.

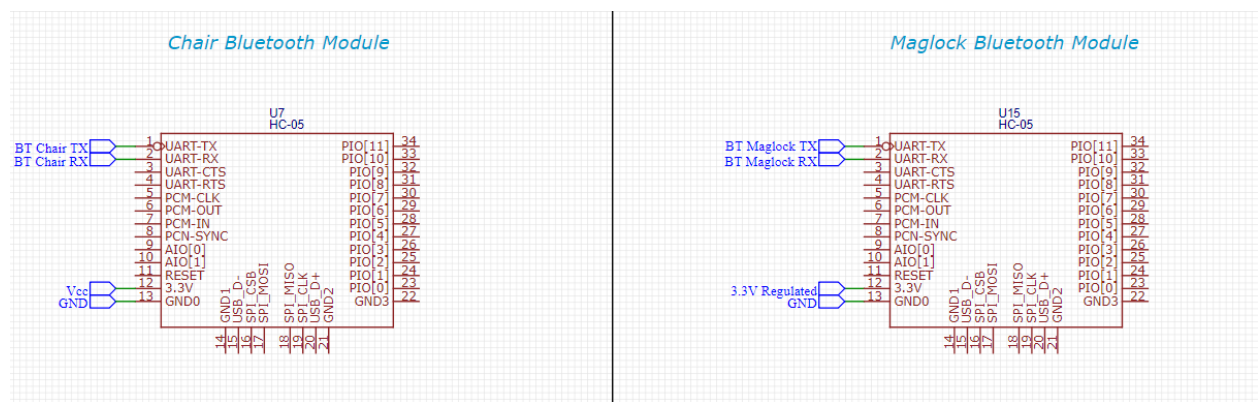

Figure 27. Bluetooth Module Pin Layout for Chair Module and Maglock Module.

The default name of this device will appear as “HC-05” and the default password will be either 1234 or 0000. The default communication is set to slave, but can be changed to operate in master or slave/master as well. The mode is defaulted to data mode which is used to send and receive data between devices. The other mode, command mode, is used to configure the device settings. The default data mode baud rate is set to 9600 and the command mode baud rate is set to 38400.

The HC-05 Bluetooth module uses USART to transmit data. Both the MCUs support UART serial communication. USART can run in synchronous mode, allowing the data rate to be much higher than the standard UART. For our project, UART should be able to handle the simple data transfers we need. USART has the same capabilities as a UART, so that is how we will use the bluetooth module to communicate between both MCUs.

5.5 Desk Chair Enhancements

The module that will be attached to the user’s chair will contain the hardware needed to provide feedback to the user when their attention drifts from the computer screen. The chair module will contain the vibration mechanism that will activate when the user has lost focus for an extended period of time, a pressure sensor that will determine whether or not the user is sitting in their chair, a Bluetooth module that will be used for communication with the computer, and a source to power all of the components of the chair module.

5.5.1 General Chair Module Flow Diagram

A flowchart depicting the breakdown of the process taking place within the chair module is shown below in Figure 28. The input to this system will be from the weight sensors to determine if the user is sitting down at their desk. From there, if they are seated, a signal will be sent to the main module indicating the module is ready to start the eye tracking system. Once the system has begun, the main computational module will be able to send a signal via bluetooth to the secondary computational module on the chair. This module will be connected to the vibration mechanism and will be able to turn it on and off depending on the input from the eye tracking software. The main module will signal the secondary module whenever the user looks away from the screen for longer than the set grace period, meaning the vibration mechanism needs to be initiated.

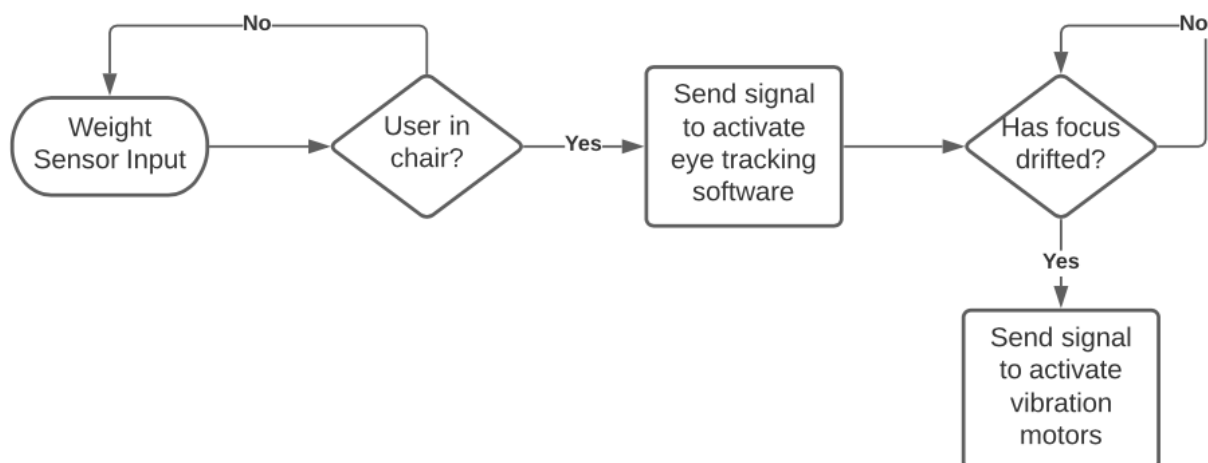

Figure 28. Block Diagram for Chair Module

5.5.2 Vibration Mechanism

The vibration motors are a key aspect of the project as they are needed to alert the user when their attention has drifted from what they are supposed to be focused on. If the vibration is too light, the user will not feel it and will not be alerted so that they return their attention to the screen. Upon researching different types of vibration motors, many of the selected styles of motors are commonly used in small electronic devices such as cell phones and smart watches. Anything this size will not provide enough of a vibration for the user to be able to feel. However, cylindrical eccentric mass vibration motors are available in a wide variety of sizes and are easily scalable to fit certain needs. They can be used in applications as small as handheld devices and as large as massage chairs. Considering that our need is inside a chair module, the cylindrical eccentric mass motor would be the best fit.

The vibration motor that we have chosen for our design is the “Black Shell DC 12V 5000RPM Vibration Motor for Massage Cushion 2pcs” available from the seller “xinyi yuan keji xian gongsi” on Amazon. These vibration motors with a rated voltage of 12 V each are designed for use in the cushions of massage chairs. This should work perfectly for our design as the vibration motors are going to be implemented into the cushion of the chair module. The use in massage chairs also tells us that it will have enough of a vibration to be felt by the user sitting in the chair. These motors, shown in Figure 29, come in an enclosed plastic case, meaning that it will be easier to implement them into the seat of the chair module as we will not have to worry about making space for the eccentric mass of the vibration motor to freely rotate without getting caught on some kind of impediment.

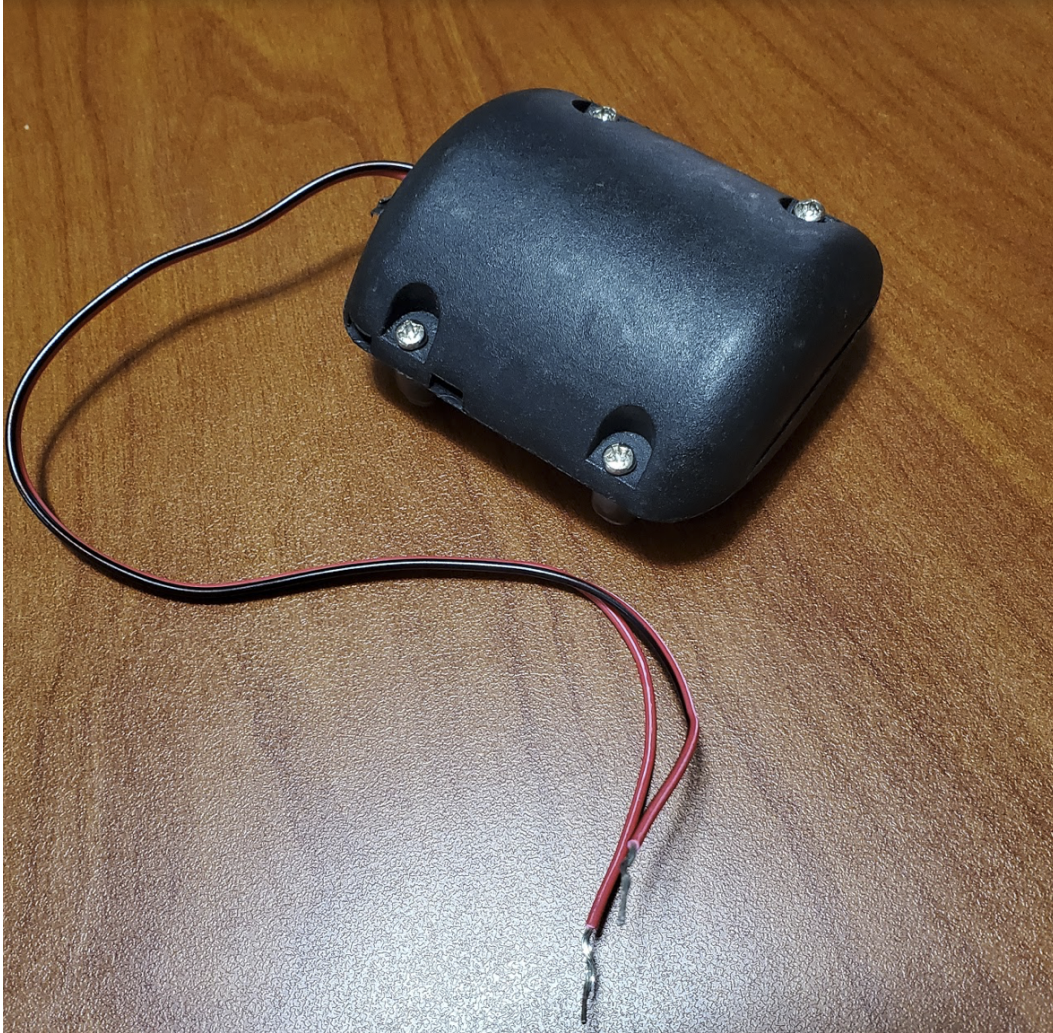

Figure 29. Encased Vibration Motor

5.5.3 Weight Sensor

The chair pressure sensor must be able to support the readings of relatively large weights as it will be sensing the user as they are sitting in the chair. For this purpose, we have chosen to use strain gauge load cells to measure the weight of the user when they are seated. Strain gauge load cells have a common use in household digital scales, so they will be able to read the weight of a human. Since the strain gauge load cell was decided to be the option that best suits our requirements, we then needed to find a product that would work for our design.

The product that was chosen was “4pcs 50kg Load Cell Half-Bridge Human Body Scale Weight Weighing Sensor + 1pc HX711 Amplifier AD Module for Arduino” which was purchased from the seller “DIYmalls” on Amazon. This product, shown in Figure 30, contains four strain gauge load cells that are individually capable of reading weights up

to 50 kg (about 110 lbs.). When the four cells are used together, they are capable of reading weights up to 200 kg (about 440 lbs.). The product purchased also includes an HX711 load cell amplifier which will be used to easily read the weight measured from the load cells for use on the microcontroller. Although the product is listed and described as being used for Arduino, it is not exclusively compatible with Arduino and can be implemented with the microcontroller chosen for the chair module.



Figure 30. 4pcs 50kg Load Cell Half-Bridge Human Body Scale Weight Weighing Sensor + 1pc HX711 Amplifier AD Module for Arduino

5.5.4 Power Source

The vibration chair module is to be powered by a single, 12V rechargeable 7AH lead acid battery. To ensure that the battery outputs a constant voltage of 12V instead of the varied output discharged over time, a 12V DC-DC voltage regulator will be implemented right after the battery in series. This ensures the constant 12V output from the battery throughout the lifespan of the battery's charge.

From this 12V output voltage, the DC motors will be powered. Set up in parallel, 4 switching circuits will be set up, much like that of the switching circuits of the electromagnetic locking mechanism. The power MOSFET being the main switching mechanism, a DC motor will be connected in series to the drain of the MOSFET, and

the source is connected to ground. To prevent the transistor from experiencing overvoltage at the gate, a flyback diode will be implemented in parallel to the DC motor.

Between the gate and source terminals of the transistor will be a 10k pull-down resistor, which effectively pulls the signal down to ground and takes all ambient charge out of the equation (i.e. the gate will not turn on without intention). Also connected to the gate terminal of the MOSFET will be the 10 ohm resistor, which ensures that only small current will be drawn from the microcontroller switching signal. Since the voltage coming from the microcontroller I/O signal is 3.3V, which is above the rated threshold voltage of the power MOSFETS intended on being used for the purpose of this project.

To power the microcontroller, the voltage from the lead acid battery must be stepped down to 3.3V, therefore another voltage regulator will be used. Branching from 12V battery source, the 3.3V regulator will be implemented, stepping the voltage down to a usable range for microcontroller operation. From the microcontroller, the weight sensors, bluetooth model and amplifier will be powered. Figure 31 is a schematic including the vibration module power and activation circuit.

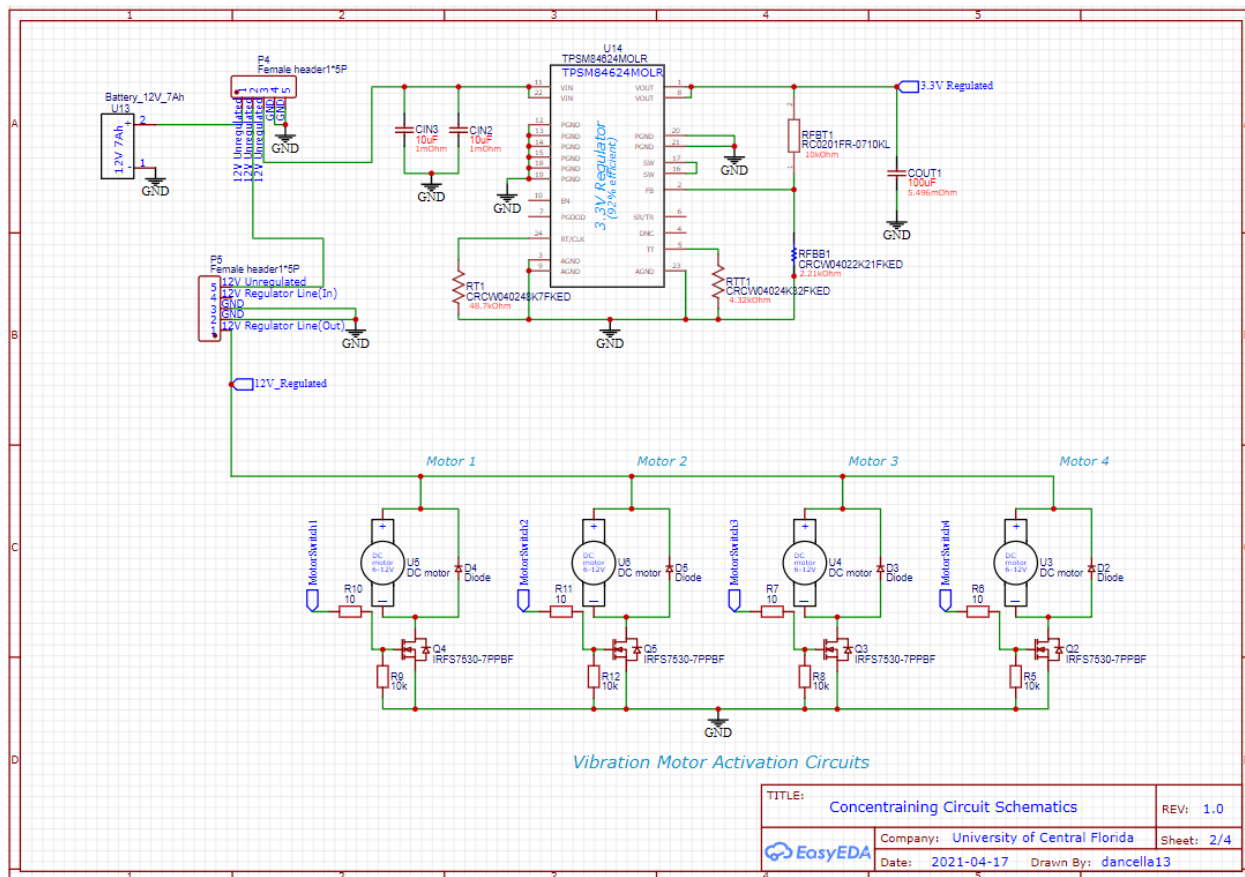

Figure 31. Vibration Module Power Circuit with Motor Activation Circuit

5.5.5 Mounting Apparatus

The vibration motors and weight sensor will be built into a separate seat cushion designed to be placed on top of the desk chair seat. This seat cushion will need to be secure so it does not slide around or fall off. Having this secure will also allow for the most accurate readings from the sensors and will ensure that the user will feel the vibration. The seat cushion will have straps attached on all four sides that will wrap around the bottom of the chair. By securing the cushion from the front, back and both sides it should not move. The straps will have velcro on the ends to connect the front and back straps and the side straps under the chair.

Since the microcontroller will not be housed inside the constructed seat cushion, it will have to be affixed to the chair in a different way. This will be done by using similar straps used on the seat cushion, but this time they will wrap around the back of the chair. The microcontroller and power supply will be attached to this strap in a pouch or similar fashion. Wires will need to run from this apparatus to the vibration motors and weight sensors in the seat cushion.

5.6 Phone Locking System

This section goes into detail describing the overall design of the smart lock jail system. Topics such as the lock box's physical design, locking system/power design, weight sensor and status symbols are all discussed in great detail, accompanied by design documents and diagrams.

5.6.1: General Lock-Box Logic Flow Diagram

This section provides a visual reference into the logic involved in how the hardware components of the smart lock box work together. The flowchart in Figure 32 shows the logic for these components. Further descriptions to each component and why they were selected for the purpose of this project are described after. This logic flow diagram shows the actions that will be taken by functions programmed into our system as a result of reactions from the current statuses of the lockbox in reaction to what our eye-tracking system is registering, alongside the status of our lockbox system. For example, different events should be triggered when the user is currently on a break versus when the user is not on break. Some of these actions coincide with those that could happen in the vibration chair module, whose events are represented in the logic flow diagram previously seen in Figure 28.

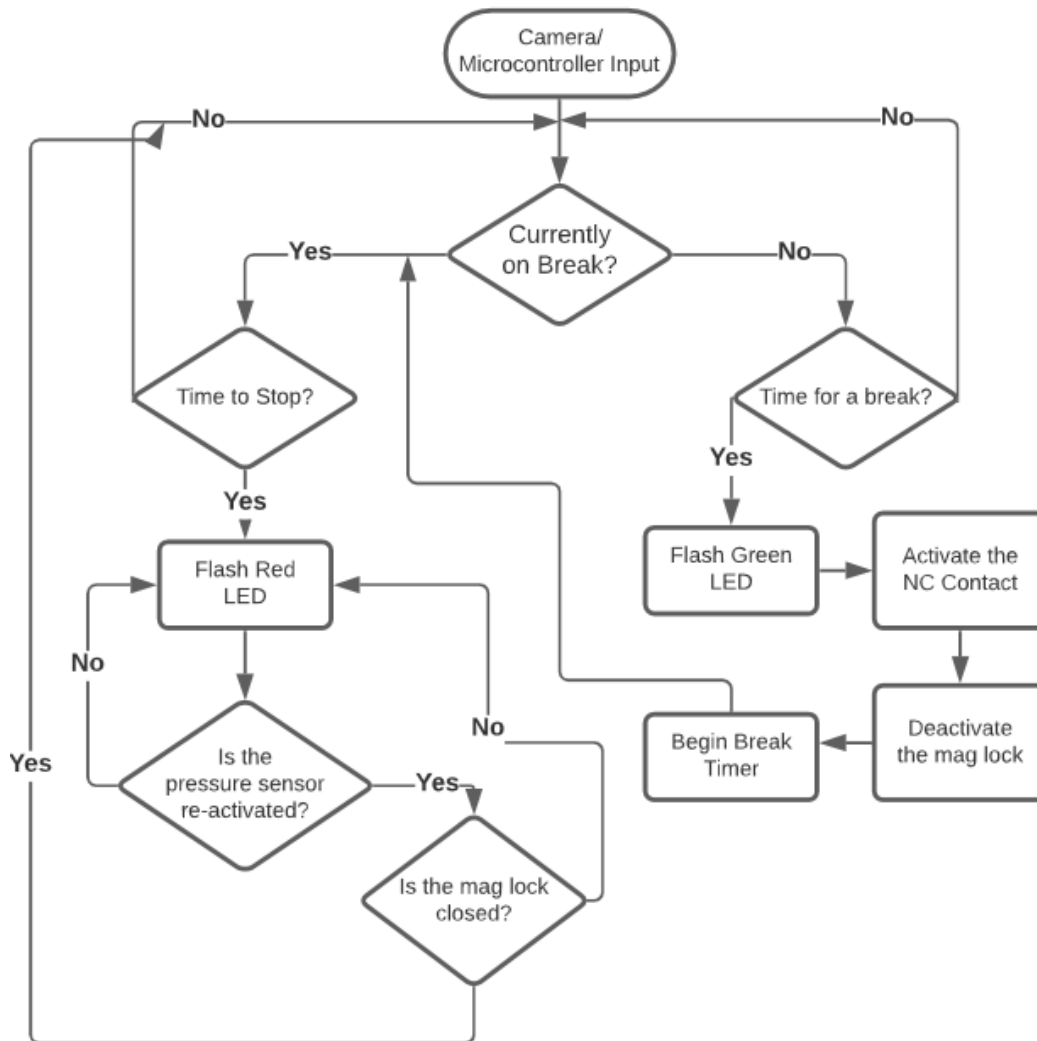

Figure 32. Smart Lock Box Logic Flow Diagram

5.6.2 Lock Box

This section dissects the design process related to the physical housing of the smart lock box. Some topics to be discussed in this section are the decision on box material, size, shape and opening/ closing mechanism of the box.

For the design of the box, we want to choose a material to construct the box that will be the most cost effective while also being able to support the features added on to the box. Cell phone lock boxes that are available for purchase tend to play into the theme of a “cell phone jail” by constructing the box to look like a jail cell with metal bars where the phone inside can be seen. For our design, this method would not be ideal as our goal is to keep the user free from all distraction that their phone may provide. If our box had gaps so that the user could still see their device, they could still be distracted by notifications they may receive. Keeping this in mind, it would be best for us to construct

the lock box out of a solid material. Potential options for the material of the lock box could be wood, metal, or plastic. Since both wood and plastic would be more cost efficient and easier to work with than metal, one of these would be the best choice to design our box.

With the material of the box chosen, the next big decision would be the orientation of the box and how the user would insert their phone. Since the lock box is meant to be placed on the user's desk, we want it to take up the least amount of room possible while still being able to contain various sizes of cell phones. The first possible orientation would be an upright box with a forward facing door for the user to insert their phone, similar to the prototype sketch shown in Figure 17. This design would take up minimal space on the desk as the user would stand their phone upright inside the box and lean it against one of the interior walls. With the upright box, one potential issue is that it may become off-balanced with the additional features that will be attached to it, such as the electromagnetic lock and the PCB. If the additional features cause the box to become unbalanced, there is potential for it to tip over easily, especially when opening and closing the door on the box. If the box were to tip over, some of the features on the box or the user's cell phone inside the box may become damaged.

Another option for the lock box design would be to lay the box down with a door on top so that the user would lay their phone down flat inside. This design would take up more room on the desk than an upright box, leaving less space on the user's desk for them to work. This design would be more stable but if we were to attach the PCB directly to the outside of this box, there would be less surface area to work with. One way to get around this issue would be to create a separate compartment below where the weight sensor would be to place the PCB in the base of the lock box. This could lead to some issues relating to overheating and needing to route wires inside the box.

One of the major concerns for this portion of the project is the exposure of the smart device and electronics to the electromagnetic locking mechanism. Taking this into consideration, we can take measures to protect these elements from electromagnetic interference. One way to do this would be to line the inside of the lock box with EMI shielding material. Taking this extra precaution will ensure the longevity of our components as well as the user's device.

5.6.3 Smart Locking System/Power Design

To implement a strong magnet into this design requires a higher voltage power supply than can be supplied by the typical computer USB port. The magnet to be utilized in this design, shown in Figure 34, is to be at least 12VDC in range, enough to withstand 60kg of force. Using such a strong magnetic lock amplifies the deterrent created by our

system, not only creating an effective locking safe, but allowing the user to focus more on their work rather than worrying about looking at their smart device.

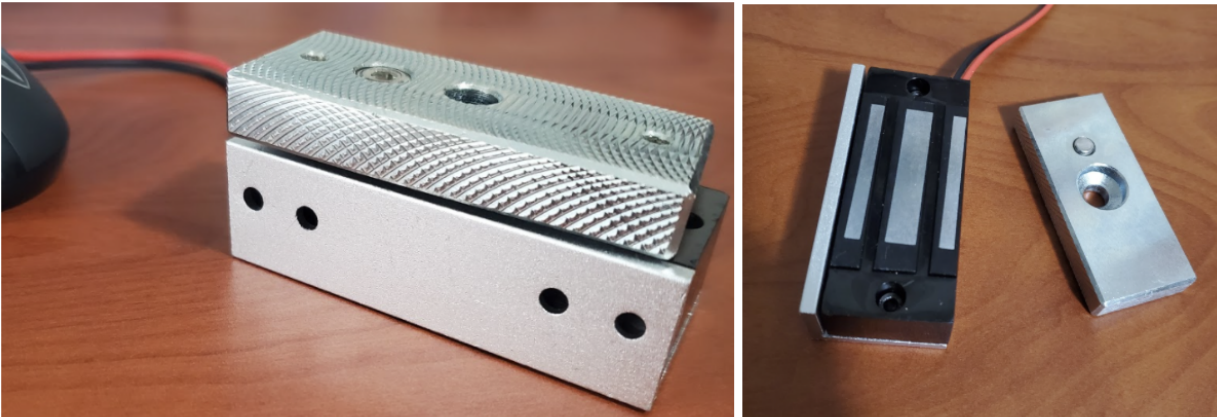

Figure 33. V Electromagnet

One benefit to using this type of lock specifically is seen in the little button on the metal bar counterpart (pictured right). It is essentially a small, spring loaded trigger. When the magnet is activated and the two plates are in flush contact, the trigger becomes compressed. However, when the magnetic circuit is deactivated and no more power is flowing, the force of the spring pushes the contact away from the magnet, minimizing any residual magnetic effect on the circuit.

To achieve this power, a 12V ACDC 2Amp Converter plug is to be utilized, solely providing power to the magnetic lock. If this source were to be connected to the microcontroller line, it could possibly cause damage to the brains of the smart lock box, given that it typically runs between 3.3 and 5V. The plug is shown below in Figure 34.

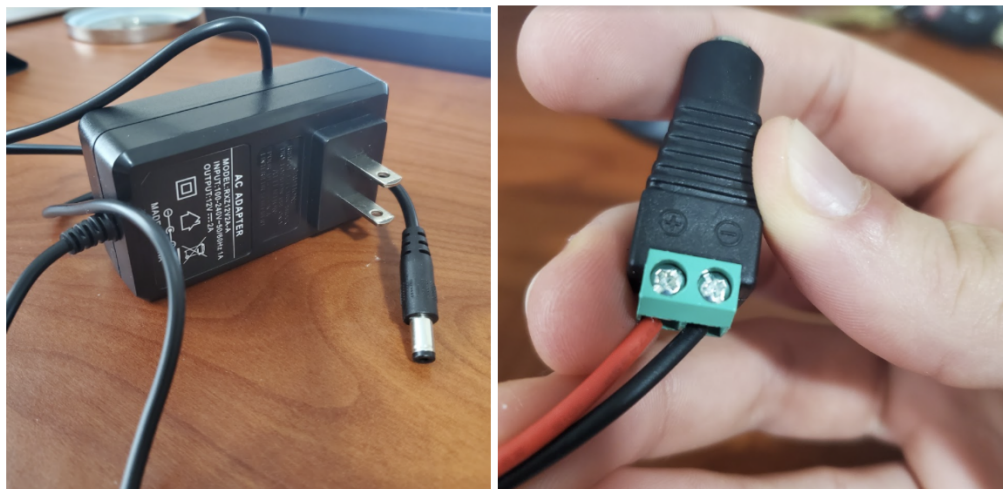

Figure 34. V 2A ACDC adapter with connector pin

To prevent the cross-power from occurring, a relay or a Power MOSFET will be implemented. In both cases, they would act as some sort of a “switch”, using the lower voltage level coming from the Microcontroller panel to determine whether or not the power from the plug should be flowing to the electromagnetic lock, completing the locking mechanism. This method allows for control between two different voltage level sources, without either of them interacting and harming each other. Figure 35 displays the circuit diagram for the magnetic locking switch circuit.

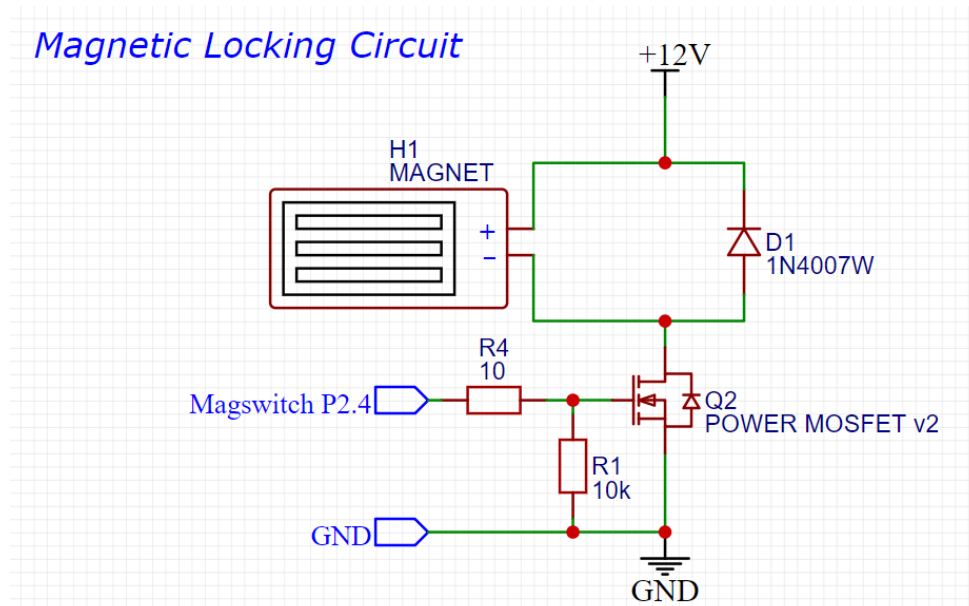

Figure 35. Magnetic Locking Switch Apparatus with Power MOSFET Integration

As seen here, a “flyback” diode has been implemented in parallel to the magnetic lock in order to prevent excess voltage being experienced at the drain of the MOSFET transistor. R1 represents a pulldown resistor between the gate and source of the MOSFET. This is essential for keeping the states of the switching mechanism distinct, because if this resistor were not implemented, then it would be possible to even the static energy in the air to trigger the switch when it does not want to be switched. A small resistor, 10 ohms, is placed on the same line as the trigger pin in order to limit the current flow experienced by the gate terminal.

5.6.4 Weight Sensor

The lockbox pressure sensor must be able to sense the weight of the user’s cell phone being placed in the box and then communicate that information to the microcontroller so the system knows when the lock should activate. For this weight sensor, we decided to use a homemade sensor design using velostat. Velostat comes in sheets that can be

cut to the desired size for use, which makes it ideal for implementing into the small space inside the lock box.

Velostat is also a piezoresistive material, meaning that it changes its resistance whenever a force is applied to it. This should work well for the lock box sensor as there will not be much weight applied in the form of a cell phone, but there will be enough force applied to the sensor to detect a change in the resistance. Also, since the phone will be stationary while in the box, we should not have to worry about fluctuations in the reading of the resistance.

To construct this weight sensor, additional supplies to the velostat will be needed. Some form of structure will be needed to form the top and bottom layers of the weight sensor. This structure must be sturdy so that it will not dampen any of the pressure applied to the sensor. If the structure chosen does dampen the force applied, we will not get an accurate reading from the sensor. Attached to these structural layers will be a conductive material.

For this sensor, we have decided to use copper tape. Copper tape is a conductive material that is adhesive on one side, which will allow us to easily attach it to the structure. On each of the two structural layers, multiple strands of copper tape will run parallel to each other with a single strand running perpendicular across the other strands. The strands that run perpendicular to the others will be used to attach wires to the sensor so that we can supply a voltage to it and read the change page in current when weight is applied.

The copper tape on one structural layer must not touch any of the copper tape on the other, as this would complete the circuit with the velostat's resistive properties not having an effect on the reading. To combat this, the copper strands of copper tape running perpendicular to the others will be placed on opposite sides of the sensor, while the strands running parallel to each other will have the velostat as the buffer between them. The image shown in Figure 36 below demonstrates a deconstructed weight sensor created using velostat and copper tape.

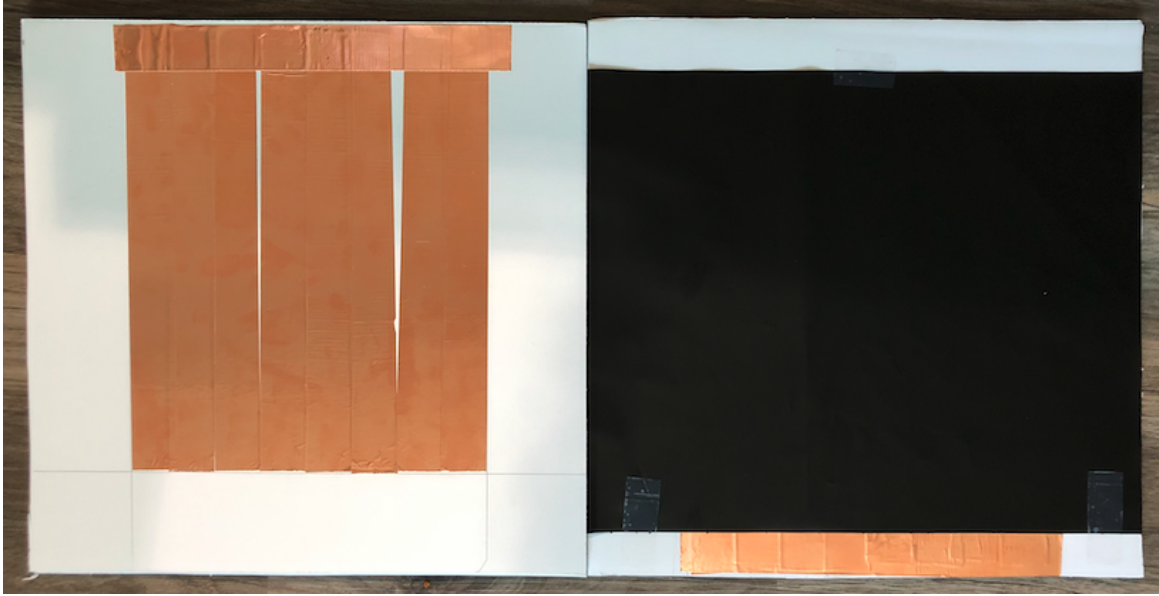

Figure 36. Deconstructed Velostat Weight Sensor

5.6.5 Status Light

To account for the status of the user's phone break accessibility, two status lights, connected to the microcontroller board via IO pins, will be utilized. Relatively simple in concept, the green LED would signal the user to enjoy their break for the time being, while the red LED would signal the user to place their phone back into the safe. To minimize distraction during periods of concentration, the status lights will be inactive until it is time for a break, and will remain on for the duration of the break. Figure 37 shows the circuit LED notification circuit, consisting of two lines of triple parallel LEDs.

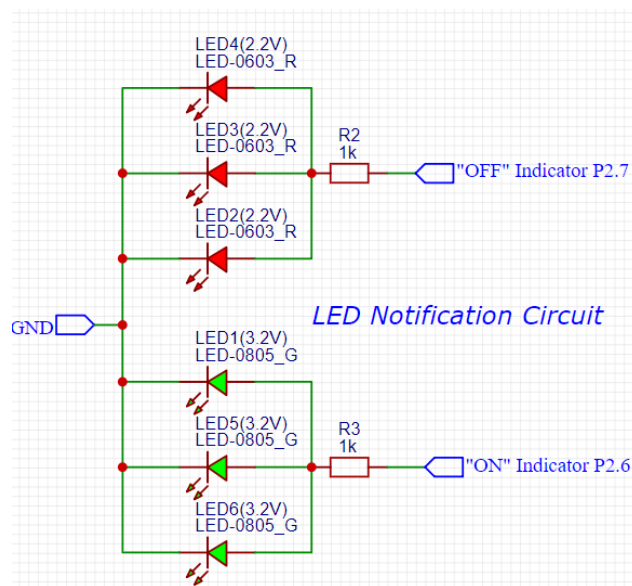

Figure 37. LED notification circuit

5.7: USB Power and Data Circuits

This section will be used to describe how USB power and data will be hooked up to each of the microcontroller devices, both in the maglock apparatus and the vibration chair module. Both will be the exact same circuit, as pictured below in figure XX, because both will be utilizing the same exact USB port and 5V-3.3V regulator circuit. Both are shown in Figure 38.

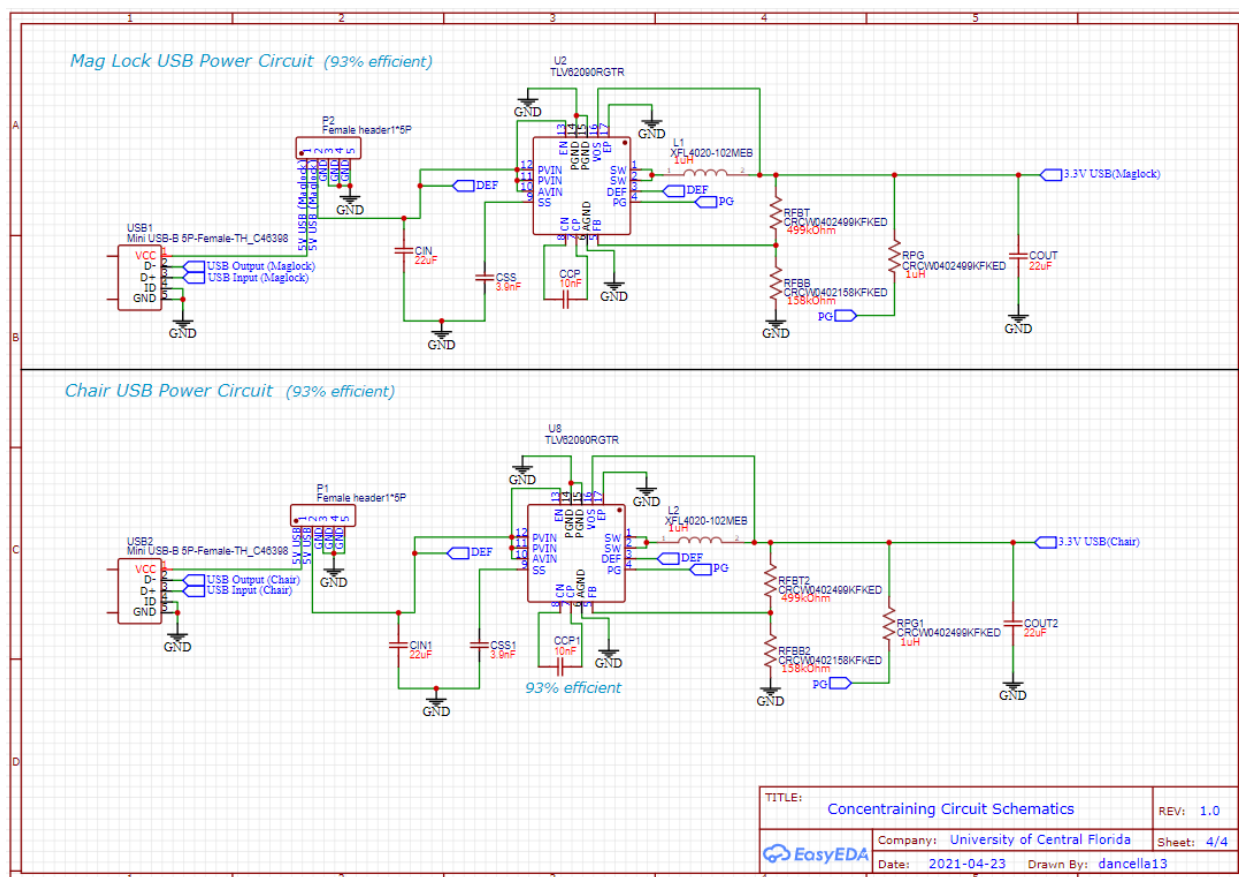

Figure 38. USB Circuit Diagrams for Both Modules

5.8 Potential Hardware Issues

With the amount of various hardware components that are going to be needed in our design, there is a possibility for numerous issues to arise. One potential hardware issue that could come up in our design is that the wires we use to connect various devices could prove to be faulty. This issue, albeit an easy one to fix as we would just need to replace the wires, could prove to be time consuming when it comes to finding where the fault has occurred. With the strict time constraints that we will have when it comes to completing our design, preventing small issues such as this will be a key factor to help us stay on schedule.

Another potential hardware issue that could arise is the weight sensors becoming deformed and not working properly. A deformation in the weight sensors, whether it be the velostat weight sensor used on the lock box or the strain gauge load cells used in the chair module, could prevent them from giving an accurate reading. When testing the chair weight sensor, we will need to determine a weight that will act as our baseline for determining if a person is seated in the chair or not.

For the lock box weight sensor, we will need to test different amounts of force on the velostat sensor to determine what resistance reading will signify if there is a phone placed on it or not. These readings will be crucial to our design as they are needed in the software when communicating to the rest of the system, whether that be to activate the eye tracking software when a person is seated or to engage the locking mechanism when the user's phone is placed inside the lock box. If at any point the sensors become deformed and do not give an accurate reading, this may prevent our system from working as intended. This would be a very time consuming issue to fix as we would need to redesign our system with new weight sensors, retest the new weight sensors to find our baseline measurements, and update the software with the new readings from retesting.

Within the chair module, there could also be more hardware issues than just with the weight sensor. The vibration motors that are used to alert the user when their attention has drifted also poses potential issues. The main issue that could come up with the vibration motors is that the motors may fail and not provide a strong enough vibration to alert the user. To fix this issue, we would need to purchase new motors and add them into the chair module. This would infringe upon both our time and budget constraints, as we would have to purchase the new motors and wait for them to be shipped.

5.9 Additional Hardware Features

Due to the time constraints, we are only able to add so many features to our design. If given more time we would like to have added more features to enhance our system and add to the user experience. One addition would be to design a state of charge indicator to display the battery life. This could have been done in a few ways. One way we considered would be using four LEDs to illuminate according to 25%, 50%, 75% and 100%. There could also be an LED to indicate that the batteries need to be replaced.

Another hardware feature we considered adding was a candy dispenser as a positive reinforcement tool. When the user has retained their focus for a set time, the dispenser would disperse a treat to encourage them to focus. This could be attached to the lock

box since that will already be on the user's desk or could be a separate optional module.

The use of flashing lights or an alarm was considered as a secondary way of regaining the user's attention. This could have been done on the software side by using the computer screen and speakers or externally by adding some lights and using the microcontroller to create an alarm sound.

6.0 Software

This section will go into detail about the software design for our project. The programming language will be determined and a flowchart will show the basic logic used in regards to eye tracking and the other hardware devices. The algorithm is discussed in detail below along with an overview of the user interface. Potential issues and additional features are also presented.

6.1 Software Design Summary

The design will include a settings menu for the user to access. The menu will include the ability to turn the software on or off along with other variable settings. The user will be able to set their unique specifications regarding how long they can look away from their screen. For example, if the user is taking notes, that might require a longer interval than watching a lecture or video. If positive reinforcement is being used, a minimum time requirement will be set that the user can adjust. Once the user has focused on the material presented for the desired time, they will be rewarded or reminded to take a quick break. The current design implements a place to lock the user's cell phone away on their desk to help them focus without distraction. To regain access to their phone, they will have to accrue a designated time with their eyes on the screen. A timer will start once they're focused with their eyes on screen and will pause every time they look away. The software will be designed to continually take input from the webcam to determine if the user is focused on the materials on screen or not. If the user is looking away from the screen there will be a time limit for them to return their focus to the screen. If that time elapses and their gaze is still off the screen, this will trigger the vibration in the chair to remind them to return to their laptop.

6.2 Software Block Diagram

Figure 39 shows a block diagram illustrating the basic logic for the software aspect of our project. The algorithm is described in more detail in section 6.3.

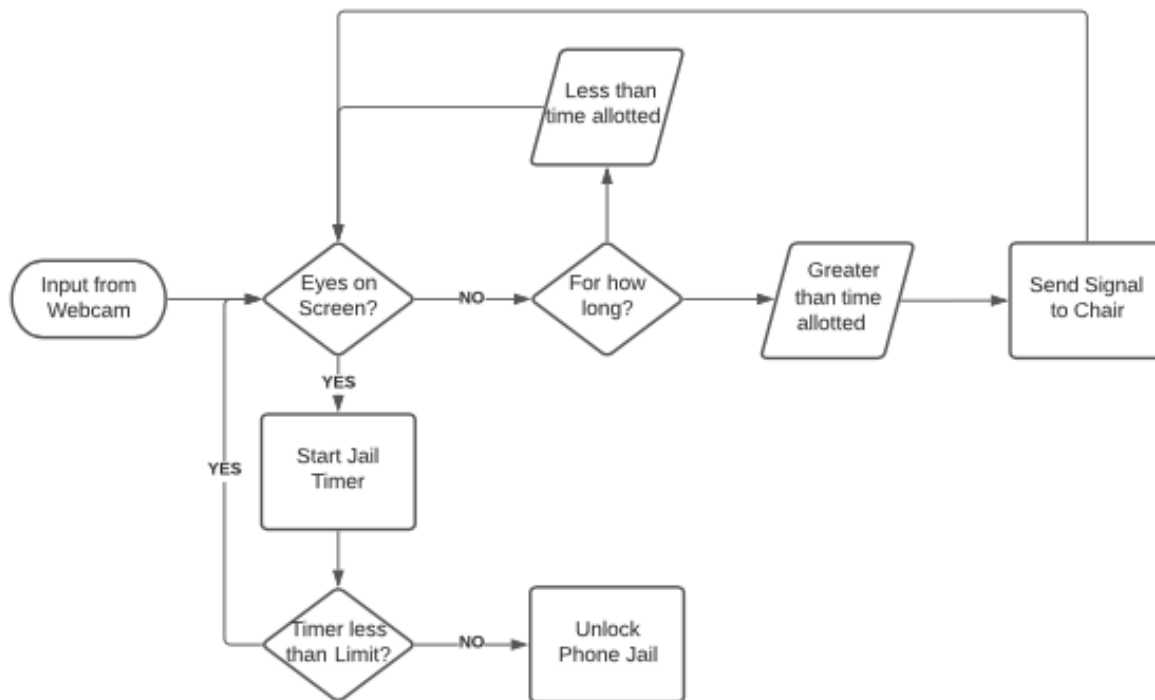

Figure 39. Block Diagram of Software Components

6.3 Algorithm Description

Once the user is sitting at their computer ready to work, they will start the system to begin the eye tracking. The weight sensor in the chair will help to determine whether there is an actual person in the chair and not just a pile of books to hit the weight requirement. The weight sensor will also be able to notify the system if the user steps away from their computer all together and not just distracted by something at their desk. The eye tracker will receive input of whether the user's eyes are detected. If the user is looking at the screen, the smart lock timer will begin. The smart lock timer will determine when the user has had their phone locked away in the smart lock box and continuously paying attention to their computer screen. Once this timer has reached the specified limit, the smart lock box door will open and allow the user to take a quick break or finish their study session. If the software does not detect eyes on the screen for more than the allowed threshold, the main communication module will send a signal to the chair module and the vibration motors will turn on briefly to regain the user's attention.

6.4 Necessary Functions

This section will describe functions our team intends to write to realize the algorithm as described above.

The core function around which the overall program will be built is the eye tracking function. As per the sample function Tobii has provided, this function takes input from the Tobii Eye Tracker 5's infrared camera and uses that input to determine where on the screen the user is looking. Each part of the screen is assigned a numerical value and for the sample function the program simply outputs the numerical values currently being observed to the user. For our program we may convert those numerical values back into a more visual chart within the app so that the user can verify that the eye tracking appears accurate.

Additionally to showing the user the eye tracking itself, our functions will be built around reading the numerical data provided by the eye tracker and taking corresponding actions based on the values given. For the purposes of our program we need only a binary set of values, 1 if the user is looking at any part of the screen and 0 if the user is not looking at the screen.

Another component of the program that many functions rely on is a timer or multiple independent timers. When our program receives a 0 feedback, i.e. that the user is not looking at the screen, our chair feedback function will begin a timer. The specifics of this timer will be configurable in the software so that users can determine what is best for them but a demonstrable value would be 10 seconds. If the user returns their attention to the screen within 10 seconds, the timer would stop, reset to 0 seconds passed, and wait for another lapse in the user's focus. If the user does not resume paying attention for more than 10 seconds, the program would then send a signal to the microcontroller on the user's chair which in turn would deliver vibration feedback to the user.

Another timer may be running at all times for the lockbox mechanism of our project. There will be two conditions necessary for this timer to count, the first is that the user did in fact place their device inside the lockbox and close the box. We aim to have a sensor inside the lockbox to detect the weight of the device so the program will get a true or 1 value from the lockbox if a device is inside. The second condition will be that the user is paying attention. If the user does not focus on the screen, i.e. the eye tracker function returns 0, our lockbox function will not count and therefore the time required before the user can access their device again will not decrease. Only after a certain amount of focused time will the timer reach its target and send a signal for the lockbox to unlock.

One additional function will be a monitoring function based on a weight sensor in the chair itself. This will be to check if the student is actually sitting in the chair and able to receive vibration feedback. Depending on the sensor we are able to get we may receive

a specific weight value from the sensor, in which case we would verify the weight based on appropriate weights for a living person. If we are unable to receive weight measurements we would simply receive a binary value from the sensor, true if there was weight present and false if there was not. In order to ensure the device is being used correctly our program will display a warning message and not run if the user does not sit in the chair while using the program.

6.5 Necessary Data Structures

Due to the nature of the program complex data structures will not be heavily utilized, many of the exchanges of information will be binary in nature, passing just a true or false value. With that said we will have the following objects. We will have an object called `Chair_Weight` that includes either a float value or binary value to indicate the response of the weight sensor in the chair. A similar object called `Box_Weight` will provide the same content based on the sensor in the lockbox. We will have an object called `User_Focus` that updates with the response of the eye tracking function to hold a float that indicates where the user is looking.

One of our more complex data structures will be `User_Settings` which will hold information about the customizable settings chosen by the user. Fields for this structure will include `Response_Latency` as an integer in seconds, as well as `Vibration_Length` as an integer in seconds. A char array called `User` will identify the user for instances of multiple profiles within a single device and a char array called `Color_Scheme` will allow users to select between Light and Dark modes in the user interface. `Use_Lockbox` will also be available in `User_Settings` as a binary value to let the program know if the user intends to take advantage of the lockbox device. Additionally `Locked_Time` will exist as an integer in `User_Settings` as a way for users to set a time in seconds that they would like the lockbox to be locked for.

6.6 Software Flow

The core function of the program will begin when the user selects “start eye tracking” from the user interface. A check will be performed to see if `Chair_Weight` holds an appropriate value, if it does not the user will receive a pop-up message informing them that they need to sit in the chair, if it does the program will begin. The `User_Focus` object will begin updating via the eye tracking function and the function monitoring `User_Focus` to apply vibration feedback will await a flag triggered by the monitoring function returning a 0 value to `User_Focus`.

If the flag is triggered, a timer will begin corresponding to `Response_Latency` within the `User_Settings` object, as well as enable a new flag to check for a non-zero value in

User_Focus. If the new flag is triggered before the timer has finished its count, then the program will reset to its earlier state, with associated timers and flags reset to their default positions. If the timer finishes its count a signal will be sent to the microcontroller on the chair to deliver appropriate feedback as per Vibration_Length in User_Settings. After this signal the program will reset to its earlier state as well with associated timers and flags reset to their default positions. The initial flag for a 0 value in User_Focus will not be reset until the vibration feedback has been delivered so as to not enter a feedback loop. Whether this is timer based or based on a response from the microcontroller will depend on the complexity of the microcontroller obtained by our team.

If the lockbox function is utilized by the user, that function will begin along with the eye tracking as well, the lockbox will not lock magnetically until the Box_Weight variable reads an appropriate value. If the user tries to begin the program with the Use_Lockbox variable set to 1 but with Box_Weight set to 0 the program will produce a pop-up to remind the user to place their device inside the lockbox. Once those two values line up correctly the lockbox will lock magnetically and a timer will begin. The rest of the functions will not begin until the lockbox function begins if Use_Lockbox is set to 1. As long as User_Focus is non-zero the timer will continue to count. When the timer reaches the value specified in Locked_Time the lockbox lock will release and a pop-up will appear to the user to congratulate them on reaching their studying goal. This will also pause the eye tracking until the user starts it again.

6.7 Choosing the Right Software

This section will review different software options our team considered and how we made decisions between them. Ultimately after weighing the options shown in Table 13 our team selected C and Java as our primary programming languages for this project. C will be the core of our programs functionality and Java will be the core of our programs design and User Interface. C and Java had an edge among the languages as our programmers had experience with them and they were the best suited for the purposes they have been chosen to serve.

Programming Languages	Pros	Cons
C	<ul style="list-style-type: none"> - familiarity/experience - Interfaces easily with microcontrollers - Existing C code provided by Tobii 	<ul style="list-style-type: none"> - Lack of automated functions like memory cleanup - Not as nice for UI

C++	<ul style="list-style-type: none"> - Existing C code provided by Tobii - Has some features of C and some features of more object oriented programming languages 	<ul style="list-style-type: none"> - Lack of experience/familiarity
C#	<ul style="list-style-type: none"> - Existing C code provided by Tobii - Has some features of C and some features of more object oriented programming languages 	<ul style="list-style-type: none"> - Lack of experience/familiarity
Java	<ul style="list-style-type: none"> - Great for UI - Lots of automated functions and helpful libraries - familiarity/experience 	<ul style="list-style-type: none"> - Lack of existing support from Tobii - May not interface with microcontrollers directly as easily
Python	<ul style="list-style-type: none"> - Very versatile - Lots of automated functions and helpful libraries - Some familiarity/experience 	<ul style="list-style-type: none"> - Lack of existing support from Tobii - May not interface with microcontrollers directly as easily

Table 13. Table comparing programming languages

6.8 User Interface Overview

The goal of the user interface will be a single web app to control the eye tracking software as well as any associated settings on the smart lock device and mechanisms on the chair.

The web app will be written primarily in Java though communicating with each associated mechanism of the chair and smart lock device may require programs in additional languages.

A stretch goal of the project is for the web app controlling the product to also be able to collect and display data about how the eye tracking and associated mechanisms have functioned. Stored data about when users lost focus in a studying session or how often they used the emergency release on the smart lock device can help users improve their own habits or be used in associated research on eye tracking and types of feedback.

One primary function of the web app will be a button to turn the eye tracking on and off. Depending on the eye tracking we are able to apply this may also require a button to calibrate the eye tracking for it to be more effective.

An additional function of the web app will be the ability to designate part of the screen for the eye tracking to track. Typically the default application of this product will be making sure the user is watching the screen in general, but if the user would prefer attention remain on a specific part of the screen, the product should allow for that.

Further configuration will also be done through the web app, such as adjustments to the vibration settings on the chair. Ideally this user interface will allow users to adjust how much the chair will vibrate in response to a period of inattentiveness by either adjusting the speed, power or duration of the vibration mechanism.

Similarly the user should be allowed to adjust how long they are allowed to be inattentive before any feedback is delivered.

Although the primary goal of this product is to serve students wishing to self improve, it may be the case that it is obtained by guardians who want students in their care to use it. For that we may allow a form of parental access in which the initial user who sets up the product can lock the settings behind a passcode, thus preventing a student in their care from making changes to the settings that would void the purpose of the product.

The web app should also allow for some configuration of the smart lock device, with the ability to lock and unlock the device both built in. For situations where the smart lock device should unlock automatically after a certain duration, that duration would be set in this app as well.

Shown below in Figure 40 is a mockup of what the web app could look like. This is a very basic mockup that leaves a lot of room for change but highlights the core functionality our team would like to include. There are four main buttons for the main functions, starting the eye tracking, stopping the eye tracking, calibrating the eye tracking and adjusting all the settings that are available for the user to adjust.

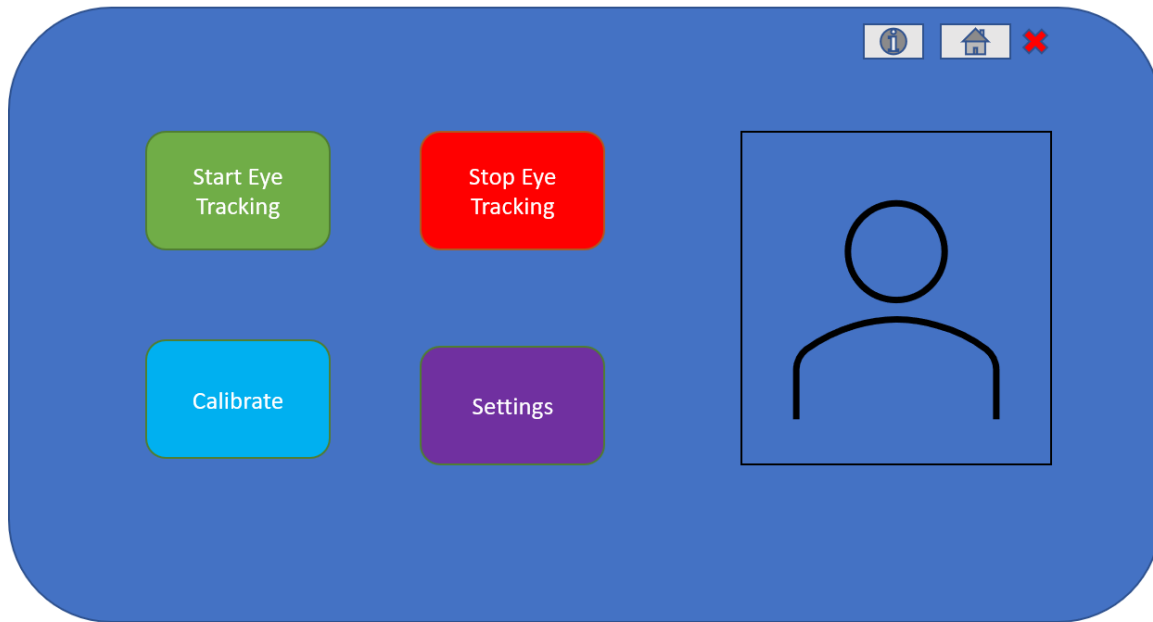

Figure 40. Minimal Design for the Web App

At the top right of the web app are a close button, a home button to return to this main screen from other views in the app and an info button for users struggling with navigating the app.

Below those three buttons is a screen that will in some way show how the eye tracking is going. Either a full head view or a window of the users eye placement on the chosen window will be displayed. Clicking on this screen will allow users to adjust the window that the eye tracking is applicable in.

The color scheme as demonstrated here is not final, bright contrasting colors have been used to easily identify the buttons and a blue background to differentiate the window from the white background of our paper. For the final product the web app will utilize a color scheme more consistent with the branding of this project and offer both light and dark modes in the settings tab as well as potentially other color schemes.

6.9 User Control and Security

For this project user security is a high priority. A rival project to Concen-Training known as HonorLock has come under a lot of scrutiny and received a lot of backlash regarding privacy concerns based on using the users camera to keep an eye on them while test taking. Concen-Training will take a few steps to mitigate security risks and give users more control over their privacy

One big differentiator that allows Concen-Training users to maintain their security is our use of infrared cameras like in the Tobii Eye Tracker 5. These infrared cameras focus entirely on recording eye movement without picking up footage of the user's body or background. Although users will still have to consent to having their eye movement tracked, the worries about having their face recorded or surroundings recorded are mitigated by this practice.

Another practice that helps keep users more secure is that Concen-Training has no plans to keep recordings of users or share recordings of users with anyone. Although we have a long term goal of being able to help users track their eye tracking goals and accomplishments, this would be done through analyzing data as obtained from the eye tracking software rather than holding onto footage of the users eyes or eye movement. Users will also have to opt-in to share data about their eye tracking behavior with others if they choose to, but will not be obligated to by our software at any point.

6.10 Class Diagram

Figure 41 illustrates the various classes and class attributes that will be used in our software design. There are currently just three classes, those being the User class, Calibration class and User Settings class. Each user will have their own userName to identify them as well as a profile which can include a picture and is the basis for which further data collection and tracking can be done. The user Type attribute will indicate if the user is a student or a Parent/Guardian setting options for the student as well as have a role option for admins should there be a need for any. Last but not least the isCalibrated option will identify whether or not this user has performed Calibration at this point.

The User Settings class will be linked to each individual user and will contain information about each setting that the user is able to change. At this moment we are planning to include some color schemes for the UI that the user can choose between such as a light and dark mode as well as different speeds for the eye tracking response so that users can adjust for their hardware. Additionally users should be able to control the strength/speed of the vibration response so that attribute is included as well and the latency timing refers simply to the amount of time spent idle before a vibration response is delivered to the user

The Calibration class is mostly handled by the Tobii software itself but will store any necessary information for calibrating the Eye Tracker for the user including information about the users eye movement, a profile to uniquely identify that information and information about the placement of the Eye Tracking device relative to the active monitor of the computer being used.

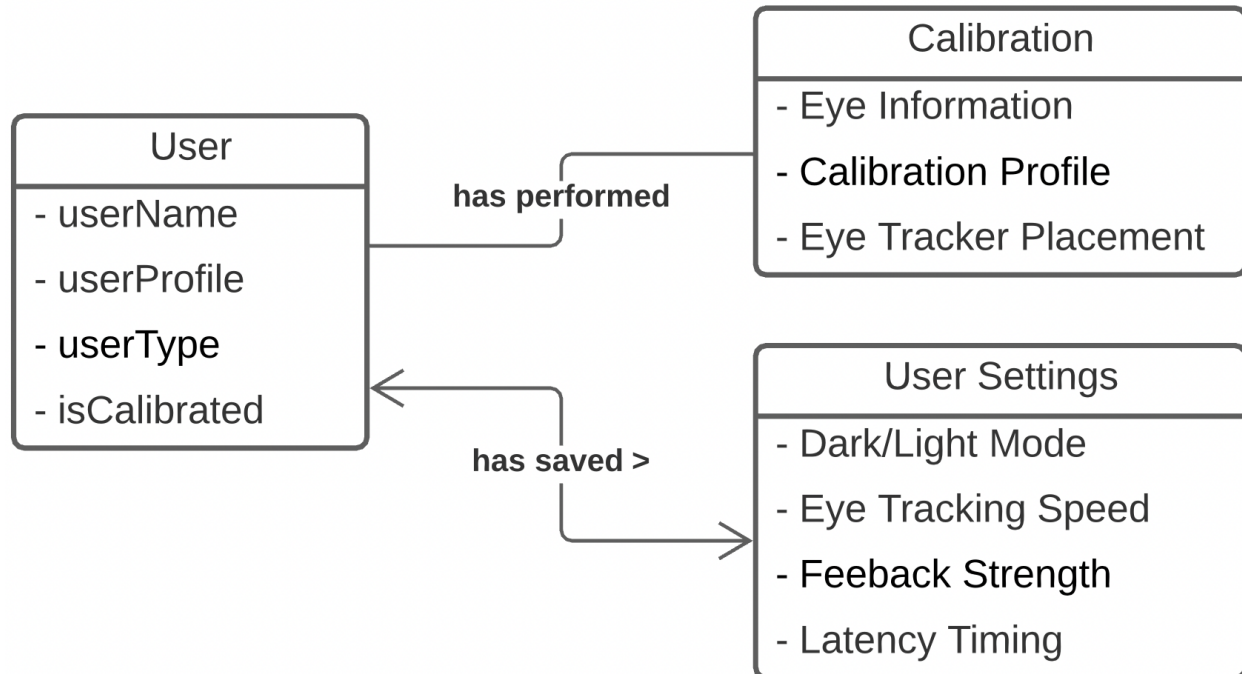

Figure 41. Class Diagram for the Concen-Training Software

6.11 Potential Software Issues

Due to both the nature of the technology around eye tracking being quite new and the inexperience of our software engineers, there are a large number of potential issues that could arise in our software.

One major potential issue has to do with the Tobii Eye Tracker 5 our team is using for this project. The Eye Tracker 5 is controlled out of the box primarily by pre-prepared programs provided by the Tobii company. Although Tobii has some sample code and a bit of documentation to help users write their own code for the device, there is no guarantee that what they allow users to do will be at the same speed and accuracy as their own program. Determining how much access users have with the device and the level of code they can write for it will determine how large of an issue we may have with the software design for this eye tracking device.

Another potential issue that our software may face is that the eye tracking device may place a heavy burden on the pc it is attached to. Adding further functionality on top of the eye tracking may cause computers with less RAM to struggle and potentially cause the program to crash.

There is also a potential issue with the eye tracking itself. Our system relies not only on detecting the movement of a user's eyes but specifically on detecting times where a user is not looking at their screen. Although preliminary testing of the Tobii Eye Tracker 5 appears to indicate the ability to do this, many alternate Eye Tracking Softwares do not have built in support for responding to eyes not being detected. Because of this there may be cases in which a user looks away but the software still thinks the user is looking at the corner of their screen, or cases in which a user looks at the corner of their screen but is registered as looking away. Both of these mistakes would result in a loss of appropriate functionality for the device and so our team will be thoroughly testing the Eye Tracker behavior for literal edge cases like these.

6.12 Additional Software Features

Given the time constraints, there are some features that we will not be able to implement at this time. If time allowed, some possible additional software features will be presented.

One additional software feature our team will examine adding is the ability to track trends in a user's eye tracking. Using data from our eye tracking software and response history, we would like to be able to show users where on their computer screen they tend to pay more attention to as well as how long they typically pay attention before needing a reminder.

Although tracking itself is one feature, another helpful feature that our team would like to add is data visualization. Automated graphs and charts to help the users understand the information collected would be a user friendly addition that made sure the tracking software wasn't prohibitively complicated for the average student.

Another feature that our team is considering for the Concen-Training software is shareable data. Although it is unlikely for a student to share their studying data on social media, we recognize a use-case for students to share this data with teachers, tutors or their parents for feedback or proof that the student studied effectively. Students can screenshot the Concen-Training application to share parts of any available data to others but having a built in share functionality may allow students to share more comprehensive information in an easier way.

7.0 Testing and Troubleshooting

The following section will lay out the procedures we will use to test the various components of our design to make sure that they will function up to the standards that we require of them.

7.1 Testing

When creating tests for our equipment, many factors will come into play. When comparing software and hardware, they will have to undergo multiple rounds of testing. We will have to ensure that the pieces work separately and together. We will determine the criterion that each product will have to reach to either pass or fail the testing stage. The overall approach to testing will be described along with any equipment needed and where the testing will take place.

One of the primary pieces of testing equipment to be used is a breadboard. With this piece of equipment, circuits for each of our PCB layouts can be tested without fear of permanent soldering or damage to existing equipment. Along with the breadboard, MM FF MF wires would be used in order to simulate permanent connections made by the PCB circuit. A voltmeter and Multimeter will also be useful to measure the voltage and current of the pre-existing circuits.

Before beginning all of our testing using a breadboard, we will run a continuity test on the breadboard to ensure that this element will not be the cause of any faulty testing results. To test the breadboard, we will need a multimeter and jumper cables. Each power and ground rails will be tested on opposite ends for continuity. Each of the numbered rows are tested for continuity as well. Once the breadboard has passed these tests, it can be used in further testing.

One final piece of equipment to be used in the testing process is an oscilloscope. An oscilloscope has the ability to measure and test varying voltages and currents on a 2 dimensional graphing display. The oscilloscope is useful for tracking and testing response times of certain circuit elements,

7.1.1 Power Testing

Two major components requiring external power are the smart lock box and the vibration chair module. This section dives deeper into how these systems can be tested.

7.1.1.1: Chair Power Testing

This section is primarily concerned with the testing of the power components associated with the vibration chair module. Our design currently consists of a power supply of 8 rechargeable AA 1.5V batteries, so a simple circuit can be created to test the voltage of each of these batteries. On a breadboard circuit, we can include an LED and resistor, connected in series to both terminals of the battery.

We will first test if each battery has some sort of initial charge with this circuit, indicated by the status of the LED light: if the light is turned on, then the battery is charged (at least charged enough to turn on the LED). More tests can be run in order to determine the specific charges of each battery, since none are technically the exact same.

One option to do this would be through acquiring a multimeter that has the ability to measure the voltage of batteries directly. This can be accomplished by directly placing the nodes of the multimeter on the positive and negative terminals of the battery being observed. Depending on the charge rating of the battery and its current state of charge, the voltage between each battery can differ. Table 14 gives a rough estimate on voltage rating and state of charge of the battery in question, as compared to pre-existing state of charge information from 12V batteries.

1.5V Battery Estimated SOC values	
Percentage Value	Voltage Level
100%	1.593V
90%	1.578V
80%	1.563V
70%	1.548V
60%	1.530V
50%	1.513V
40%	1.495V
30%	1.478V
20%	1.458V
10%	1.438V

Table 14. Estimated State of Charge Voltage Values for 1.5V batteries

7.1.1.2: Smart Lock System Power Testing

The major power source driving this portion of the device is the ACDC 12V 2A plug. In terms of testing, a continuity test needs to be done to ensure the functioning of this device. To do so, a simple circuit will be constructed on a breadboard, consisting of a series of high rated resistors. The plug will of course be inserted into the wall socket for proper environmental testing (when energized), and the adjuster cap that comes with the plug will be attached.

The two terminals of this plug will need to be utilized, one connected to ground, and one connected to the positive terminal, all done when de-energized of course. These connections will then be connected to the series resistor circuit. After these initial connections are made, then the circuit can be energized.

While the circuit is energized, the multimeter and ammeter will be utilized. The multimeter will check to make sure that the voltage reading out of the plug is 12V exactly, and any differences will be recorded. The same will go for the current reading of the ammeter, anticipating a 2Amp output.

In terms of power being delivered to the switching mechanism for the magnetic circuit, this will be discussed more in the microcontroller testing section.

7.1.2 Hardware Testing

In order to test our hardware equipment, we will need to go through testing each piece. The vibration module, smart lock and pressure sensors are a few of the main hardware products that will need to be tested.

7.1.2.1 Vibration Module Testing

When testing the vibration module, we will need to determine where the vibration can be felt, but is not overly aggressive. The selected vibration motors are rated for 12 V DC. The first step in testing the vibration motors will be to individually test each motor and make sure that they are functioning properly. To do this, we will connect each motor to the 12V AC/DC converter that will be used for the electromagnetic locking mechanism and plug that adapter into a wall outlet. Repeating this process for each of the purchased vibration motors to ensure that none are malfunctioning will allow us to move forward to additional testing for the motors.

If none of the motors are malfunctioning, we can then repeat the same test, but rather than using the adapter to a wall outlet, we will utilize a 12V battery pack consisting of 8 AA batteries. Since the vibration motors are going to be powered by a battery pack on the chair module rather than being plugged into an outlet, verifying that the motors work

as intended with the same strength of vibration will be important to make sure that they will serve their purpose.

After testing the motors to make sure that they function properly, we will then move into testing the strength of the motors. For the motors to meet our requirements, they must be strong enough for the user to feel them while they are seated. To test this, we will connect the motors to the power source and place them under a cushion on a seat. We will be able to add motors as needed to make sure the vibration can be felt by a person seated on the cushion. When performing this test, we can also test different thicknesses of cushioned material to see if one cushion will dampen the vibration more than another. This will help us in determining which materials to use for creating the seat of the chair module.

7.1.2.2 Smart Lock Testing

This section reviews portions of the smart locking apparatus and how they will be tested in our system.

The electromagnetic locking mechanism can be tested using a simple breadboard circuit, consisting of some wires and the previously tested, confirmed working AC/DC 12V 2Amp power plug. The two wires of the electromagnetic lock would be connected to the two terminals of the powerplug's connector. If the two poles of the electromagnet attract each other and "lock" together, then we know the magnet is functional.

Another testing apparatus must be done in order to find the optimal method of contact between the two plates of the magnet lock. For example, the magnet can be aligned at a variety of angles to the attracting plate, which can affect the effectiveness of the locking device. If deemed necessary, tests can be done where the metal plate is oriented at different angles to the magnetizing mechanism, and the user can rate on a desired scale from 1 to 10 how difficult it is to pry the plate from the magnet itself. This testing method is important for determining how the metal plate and magnetic component are to be oriented on the smart lock door and door frame.

To test the resistors of the circuit, this can be done in two different ways. The first of which is using the resistor color-identifying guide to ensure that the right ones appear to be in use. Then, using a multimeter, the ohmage of each resistor can be accounted for by switching to the ohmmeter and touching each end of the resistor with the probes and measuring.

To test the relay within the locking mechanism (the portion that essentially acts as a switch for the lock), another testing apparatus is to be used. If the 5V DC relay were to be used, a simple test with an LED could be implemented (if the proper equipment were not to be found). Using a 5V power supply, one line would run through the relay, acting as another nodal point completing the circuit for a simple LED. another line would run solely through the relay

7.1.2.3 Weight Sensor Testing

When testing the pressure sensor, we must identify a range of appropriate weights for which the sensor should trigger. A weight too light should not trigger the sensor.

7.1.2.3.1 Lock Box Weight Sensor Testing

For the smart lock box, velostat material will be used to construct the weight sensor. To do so, copper tape will be applied to two pieces of solid material such as thick poster board or wood. Between these two sheets, velostat will separate the copper tape so that none of it is touching. The negative terminal of a battery pack with two AA batteries will be connected to the negative terminal of a multimeter. The positive terminal will connect to one side of the sheet along the copper tape. The other sheet will be connected to a wire which connects to the positive terminal of the multimeter. We then will get a reading on the multimeter in amps. When there is no pressure applied to the sensor, it should read 0 amps. When pressure is applied it should increase the current reading. When we tried using poster board as the material to adhere the copper tape to, we would get a spike in current and then go back to 0 A. We believe that the thickness and material of the poster board may be dampening the force that is held on the sensor preventing us from getting the expected readings. Further testing will be conducted using different materials to see if we can obtain a constant current reading.

7.1.2.3.2 Chair Weight Sensor Testing

For the chair weight sensor, a set of four strain gauge load cells will be used to create a full Wheatstone bridge design. The weight read by the sensor will be used by the software to determine when the user is seated and ready to begin their study session. Testing this sensor will play a large part in the overall design of the system as we will need to know what the sensor reads when a person is not seated in the chair versus when there is a person seated in the chair. In order to test this, we will need to attach the four sensors to one another and to the HX711 amplifier, and mount this system onto some form of structural material, such as wood, metal or plastic. After mounting the cells properly, we will then need to connect the sensor to a microcontroller and calibrate them using an object of a specified weight. After completing the calibration, we will then be able to place the sensor on a seat and have people of different weights sit on it to see what it reads and if the weight tares after the user is off of the sensor. If we can

successfully obtain the readings from the sensor and have the reading reset when the user is no longer seated on it, the sensor would pass our test and we would know a certain weight that the software should use to determine when the user is seated. If any of the tests fail, we will need to determine the cause of the issue and retest after making whatever modifications may be necessary.

7.1.2.4 Computational Device Testing

This section is dedicated to testing both the main and secondary computational modules along with the wireless communication module that will be used on both devices. Both MCU boards will be put through multiple tests. The process and equipment required will be discussed below.

7.1.2.4.1 Main Computational Device Testing

The MSP-EXP430FR6989 LaunchPad Development Kit will be used in testing for the main MCU. By using the LaunchPad we can test out different connections and codes before making them permanent. This device will be connected to the user's laptop/computer and that will be its power source. A continuity test will be done to ensure that the pins are functioning properly. To do this, we will need a multimeter and some wires.

The weight sensor for the lock box will have to be tested with the board. The sensor will be connected to the board to determine the threshold for when a phone is placed on it. A simple code will be written in Code Composer Studio that will print out the values the sensor is reading. From these values we should be able to see the range when there is nothing on the sensor and then the values should increase when a phone is on the sensor. By determining the threshold, we will be able to set this as a trigger for when a phone is inside the box. More on this testing can be found in section 7.1.2.3.1.

The electromagnetic lock will also need to be tested by running a simple code to lock and unlock the box. We will be able to see if there is a delay and how long that delay is. If it is less than 60 seconds, the lock will pass the test. The same test will be run twice, once with the program telling the lock box to open after a set time, and the other will be the response time after the emergency release button is pressed. More on this testing can be found in section 7.1.2.2.

7.1.2.4.2 Secondary Computational Device Testing

The MSP-EXP430G2ET LaunchPad Development Kit will be used in testing for the secondary MCU. By using the LaunchPad we can test out different connections and codes before making them permanent.

The vibration motors will be connected to the board to see if they can be controlled by the MCU and how long the delay might be between turning them on and off. If the delay is less than 30 seconds, the motors will pass the test. More on this testing can be found in section 7.1.2.1.

The weight sensor in the chair will also need to be testing in a similar way to the lock box sensor. The threshold will need to be determined for when a certain weight has been applied. These sensors are different from the ones in the lock box and might need to be tested in a slightly different way. More on this testing can be found in section 7.1.2.3.2.

7.1.2.4.3 Wireless Communication Device Testing

The wireless communication device we will be using is the HC-05 Bluetooth module. One way to test the bluetooth device is to download a bluetooth terminal application on a smartphone and write a code that will turn the LED on or off based on the number sent from the phone. To write this basic code, Code Composer Studio, the IDE from Texas Instruments designed for MSP430s, can be used or Energia IDE can be used to interface Arduino code with MSP430 models. Using the MSP430G2ET to test this, we will connect the HC-05 as described above in section 5.4.3. Then we will write a short code and upload that to the board. The mobile application will need to connect with the HC-05 device. Once this has successfully connected, we can send data to the device. By sending a 0 from the phone, the LED should turn off. If a 1 is sent, the LED should turn on.

Another way of testing the HC-05 device will be done to see if we can communicate data from one MCU to the other. To perform this test, a bluetooth device will need to be connected to both MCUs as discussed in section 5.4.3. Similar to the test above, one MCU will send a signal to turn the LED on or off on the other MCU. This can be reversed to ensure that both devices can send and receive data as that will be necessary in our system. The device sending the data will be connected to a laptop/computer and a code to blink an LED will be written. This code will then be uploaded to the board and should send the signal to the other board. The other board will need a separate power supply.

7.1.2.5: Power MOSFET Testing

In terms of testing the power MOSFETs used throughout this system design, a simple circuit can be constructed consisting of a 12 volt DC power source accompanied by a large resistor and LED light at the drain gate, a pull down resistor between the gate and the source, and a small resistor (about 10 ohms) at the gate, connected to another

variable DC power source. The LED will be used as an indicator for whether or not the Drain to Source pathway is open or closed.

The first test would be measuring the threshold voltage at the gate node of the MOSFET, which can be done by slowly increasing the voltage experienced by the gate. Once the LED is excited, the voltage of the gate can be taken and compared to that of the data sheet of the component.

Another section that can be tested with this device is the switching time between off and on modes. This can be done using an oscilloscope, measuring the switching waveform by applying a sinusoidal voltage to the system. The time between each switching phase can be measured this way.

7.1.2.6: Regulator Testing

To test each of the regulators for functioning, the only apparent method is to do so after constructing each of the regulator circuits. We will know the circuit passes testing when each of the regulation circuits output their labeled voltage and current. If the tested values match that of what was expressed in our regulator comparison table, then we know the test was a success. If anything otherwise occurs, then we know that either the component is no good, or that the circuit was not wired up correctly as according to the schematic diagram.

7.1.3 Software Testing

To test the software of this product there will be several phases of testing. One major part will be testing the eye tracking software itself to make sure it is accurate and reliable. Once that much is achieved, we can test the User Interface to make sure users can configure the eye tracking properly, to begin and end sessions at their will and focus the eye tracking on the right content if need be. After these phases of testing are complete we will also need to test our communication modules to make sure our hardware mechanisms react to the software appropriately and in the correct time frame.

7.1.3.1 Eye Tracker Compatibility Testing

The Eye Tracker our team has chosen is the Tobii Eye Tracker 5 and so this is the device we will be doing our testing with at this stage as well as throughout the course of our project. There are a few things that need to be tested with this device both from a hardware perspective and a software perspective.

From a hardware perspective, the Tobii Eye Tracker 5 is almost a foot long and about half an inch wide and needs to be positioned in a way that it is able to view the face and eyes of the user of the computer it is plugged into. Tobii recommends positioning the

Eye Tracker below the screen of the computer and has developed software that relies on this positioning for calibration. One segment of our testing will be examining computers and laptops to ascertain whether or not they have enough space underneath their monitor for the Tobii Eye Tracker 5 to sit comfortably and whether that position will allow the device to see the face of the user across different types of computers. One immediate concern in this testing is the case of foldable 2-in-1 laptops like the Microsoft Surface series that may not have a large amount of space below the screen.

To mount the Tobii Eye Tracker 5, Tobii includes 2 magnetic mounting strips as well as an attachment for PC monitors to place the magnetic strip slightly below the screen and at an angle if need be. These magnetic strips have an adhesive back to attach to the computer and the Tobii Eye Tracker attaches magnetically to the front. We will need to test to make sure that the materials on our computers are all compatible with the adhesive used for the magnetic strips and that there isn't any inherent risk in attaching a magnetic strip to laptops that may use magnets for automatic sleep or lock functions.

The testing for the above concerns will consist of simply obtaining a variety of laptops and computers and attempting to mount the Eye Tracker onto each of these devices. Between the 4 members of this project team we have access to several computers from different companies and of different sizes that will represent a good starting sample size for testing, and if other styles or common types of computers remain after testing on our existing devices we will take the steps to obtain those devices for testing if possible. After mounting the device we will attempt to calibrate the Eye Tracking Software on the computer and make sure it is able to sense our eyes and face correctly from a comfortable sitting position, i.e. that we do not have to lean forward or backward in an uncomfortable way for the product to work.

7.1.3.2 Eye Tracker Functionality Testing

Once the Eye Tracker is installed correctly onto a computer our team will be testing its functionality as well as the functionality of any associated code we write for it.

First and foremost we've used the Tobii Experience application developed by Tobii to calibrate the eye tracker and gain a visual representation of our gaze. This application will allow us to attempt calibrating a variety of users so we can determine where any constraints lie with the device. If a user has small eyes or thick glasses, we need to determine whether or not the eye tracker can still be appropriately calibrated.

The next step is using what is known as the Tobii Concept Validation Tool to attempt a variety of tasks using our eyes alone. Things like navigating between pages, pausing and unpausing a video and highlighting parts of an image. This tool allows us to more

accurately record how well the eye tracker is picking up our gaze and how quickly our computer is able to respond to that gaze. We aim to use a stopwatch to attempt to record some benchmark tasks with this validation tool that we can use to compare the experience of different users as well as set reasonable expectations for the response time of our own functions.

Once we have determined that the eye tracker is working as specified we have to begin testing code we write for it. Tobii provides some sample code in their development kit as well as a library file to support custom applications of their hardware and software. Our team will attempt to run these sample code files and connect to this library to make sure that running code on our own computers for this device is possible. Also we can gain an understanding of response time for command line response from these tests which will factor in to our overall response time later in the development process

Once we have successfully run the sample code provided by Tobii our next test will be modifying that code. Adding additional outputs, modifying the input, monitoring outputs from parts of the code that may provide necessary intermediate data and other tasks are included in this stage of testing. We will also look at the library functions provided by Tobii and adjust or add more as may be necessary. In order to be able to write custom code for this Eye Tracker this test will need to be successful. A successful test means that the code still runs properly after we make changes to it and those changes are reflected as intended without any major repercussions to the performance of the device or the program.

7.1.3.3 User Interface Functionality Testing

Our goal is to control the mechanics and software of our project through a single webApp so that users are able to configure the final product as much as they are able to all in one place. Testing this user interface has two main parts, one being testing functionality and the other being testing user friendliness.

When it comes to functionality we will test that all buttons we create in the webApp function as expected. This starts from the very first button pressed by the user to open the webApp. Making sure the webApp opens and runs successfully and consistently is important and we will be testing for any crashes or failed starts that need to be fixed.

When the program starts any buttons, menus and displays need to be shown as expected including a button to start the eye tracking software, one to stop the eye tracking software and any controls for the associated hardware that we have created. We will test the start button and stop button by pressing them and making sure the software starts and stops as instructed, across different time intervals including very

short and very long ones. Additionally we will make sure users cannot press the stop button while the software is not running and cannot press the start button while the software is already running, as those actions if unchecked could cause problems.

Any other controls will be tested as well to make sure the appropriate response is seen in the corresponding hardware. For example if we have a setting to adjust vibration speed or strength on the chair, we will adjust the speed/strength and then trigger the vibration and observe any noticeable differences.

7.1.3.4 User Interface User Friendliness Testing

Testing the user friendliness of our user interface is also very important. This involves tests to determine how easy our user interface is for a new user to understand and testing for any sequences that may cause confusion.

We will need to bring in independent testers from our friends and family to try the product and observe their experience. To get these users to explore the tool in its entirety we may write a series of tasks we want the users to do and ask them which tasks were easy and intuitive to accomplish as well as which tasks they did not know how to do or struggled to figure out on their own. This feedback will allow us to make changes to make the controls of the user interface clear and easy to understand. Some users may not be given any instructions but may simply be asked to try to identify what the product does on their own. An ideal user interface would make its function and purpose apparent on its own and doing this test can help us reach that point.

7.2 Troubleshooting

Troubleshooting our project will entail responding to bugs and errors as we come across them. More troubleshooting steps will be added as we test and identify bugs but some general ones will be provided below.

For inaccurate eye tracking issues, some troubleshooting steps involve recalibrating the eye tracking device, resetting the display settings, closing and reopening the software and unplugging and replugging in the eye tracking device.

To recalibrate the device simply open the Tobii Experience app, click on the gear in the top right of the user interface and click on the button that says “Improve Calibration” to perform calibration testing again and reset it.

If the calibration does not work repeatedly, another good step is to reset the display settings by selecting the “Set Up Display” button underneath the “Improve Calibration”

button and helping the software correctly identify the position of the eye tracker relative to the screen being used. For a visual guide to these buttons, please see Figure 42.

If this step also does not work, closing and reopening the Tobii Experience app as well as uninstalling and reinstalling the Tobii Experience app are both options. If these steps also do not work, unplugging the eye tracker device and plugging it in again, or changing the location of the eye tracker device are additional troubleshooting steps that can be taken.

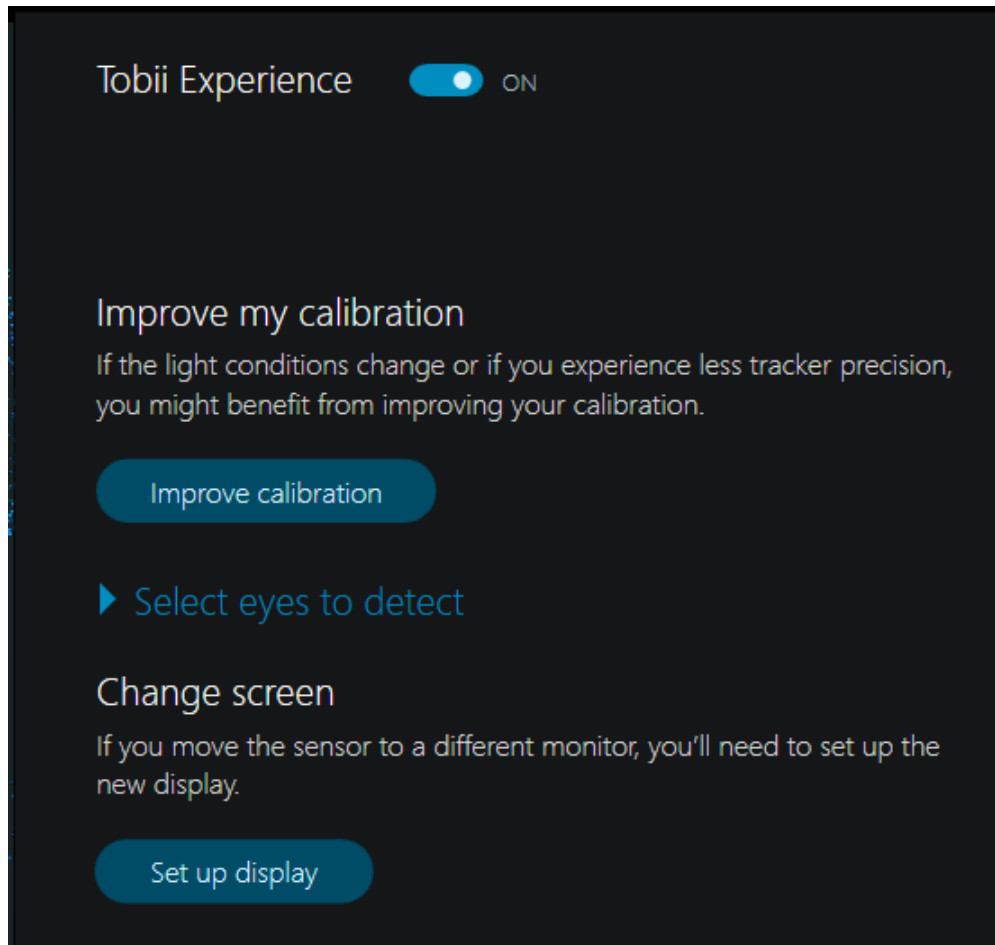

Figure 42. Tobii Experience Troubleshooting Options

8.0 Administrative Content

This section will be used to break down our milestone goals, projected budget and financial decisions.

8.1 Milestone Discussion

Described in the tables below is a collection of milestones designed to keep on track with the progression of Senior Design. Table 15 describes documents with specific deadlines to be submitted for grading. Table 16 describes group related milestones to keep on track with the development of the project overall. Table 17 specifies certain technical goals to be accomplished throughout Senior Design 1 in order to complete things in a timely manner. Table 18 specifies major milestones to be reached in Senior Design 2.

<u>Document</u>	<u>Start Date</u>	<u>End Date</u>	<u>Status</u>
Divide and Conquer 1.0	1/19/21	1/29/21	Complete
Divide and Conquer 2.0	1/30/21	2/12/21	Complete
1st Draft (60 Pages)	2/13/21	4/2/21	Complete
2nd Draft (100 Pages)	2/19/21	4/16/21	Complete
Final Draft (120 Pages)	2/19/21	4/27/21	Complete

Table 15. Senior Design 1 Deliverables

<u>Task</u>	<u>Start Date</u>	<u>End Date</u>	<u>Status</u>
Form Team	1/12/21	1/19/21	Complete
Brainstorm Project Ideas/ Decide Project Subject	1/14/21	1/29/21	Complete
Assign Project Roles / Define Weekly Meeting Times (M & F)	1/19/21	2/12/21	Complete
Table of Contents	2/13/21	4/20/21	Complete
Develop Stable Concept for Hardware/ Software Implementation	2/1/21	3/15/21	Complete
Order Components	2/28/21	4/26/21	In Progress

Table 16. Senior Design 1 Team Goals

<u>Task</u>	<u>Start Date</u>	<u>End Date</u>	<u>Status</u>
Eye-Tracking	1/19/21	2/28/21	Complete
Power Supply	1/19/21	3/15/21	Complete
Bluetooth System	1/19/21	2/28/21	Complete
Re-enforcement Apparatus Decision	1/19/21	2/3/19	Complete
Vibration System	1/19/21	4/16/21	Complete
PCB Hardware Design	2/1/21	4/16/21	In Progress
Software Design	2/1/21	4/16/21	In Progress
Pressure Sensing	2/1/21	4/16/21	Complete
Smart Lock Mechanism	2/1/21	4/16/21	Complete

Table 17. Senior Design 1 Technical Goals

<u>Task</u>	<u>Start Date</u>	<u>End Date</u>	<u>Status</u>
Recap Meeting/Project Review	1st week	1st week	Not Started
Gather Components	1st week	1st week	Not Started
Test All Components Individually	1st week	2nd week	Not Started
Fabricate and Test hardware apparatus (soldering, etc. . .)	2nd week	3rd week	Not Started
Construct Physical Apparatus	2nd week	3rd week	Not Started
Troubleshoot Software Implementation	3rd week	4th week	Not Started
Develop Project Presentation with Demonstrations, working results, etc. . .	1st week	4th week	Not Started

Table 18. Senior Design 2 Milestones

8.2 Project Economics

The following sections contain budget projections, constraints and expenditures from both the beginning of Senior Design 1 and the end. The first section, titled Budget

Projection, gives a brief overview of the projected costs of each component in our design. This can be compared with the next section, where conclusions can be drawn about the accuracy of inference we made as a team and how close we stuck with our budget.

8.2.1 Budget Projections

The maximum budget projected for our design project was agreed to be \$600 (\$150 by each student for contribution). No sponsors are currently funding this project, and all funds have been provided by the students. Therefore, there is incentive to stay within the budget and not go over the agreed upon amount. Table 19 describes a list of components to be included with this design project. The prices of these items are based on brief research of potential components to be utilized while fabricating this project, and no specific part numbers or prices will be included. These prices may fluctuate depending on availability, seller, and complexity.

<u>Item Number</u>	<u>Component Name</u>	<u>Estimated Cost (\$)</u>
1	Camera Sensor	200
2	Mounting Apparatus	20
3	Chair	100
4	Bluetooth Module	30
5	Vibration Module	30
6	Power Supply/ Power Converter	20
7	Remote Battery	20
8	Mounting Board	20
9	PCB	100
10	Microcontroller	0 (already owned)
11	Pressure sensor	15
12	Smart Locking Mechanism	30
13	Lock Box	15
Total Estimated Budget: \$600		

Table 19. Budget Projections

8.2.2 Financial Decisions and Expenditures (as of Senior Design 1)

The following section includes a table of actual expenditures for our Senior Design project so far. This will act as an active table, somewhat of a bill of materials.

Bill of Materials					
Part #	Item Name	Product #	Manufacturer	Quantity	Price (\$) (for total quantity)
1	EM Lock	N/A	LIBO Smart Home	1	16.89
2	Eye Tracking Camera	N/A	Tobii	1	229.00
3	DC Plugs	B077PW5JC3	SmoTecQ	2	11.99
4	12V Lead Acid Battery	ML7-12	Expert Power	1	21.34
5	Power MOSFETS	IRFS7530-7P PbF	Infineon	10	38.80
6	MSP-EXP430F R6989 LaunchPad Development Kit	MSP-EXP430 FR6989	Texas Instruments	1	Obtained (already owned)
7	MSP430FR6989 MCU	MSP430FR6989IPZ	Texas Instruments	1	9.45
8	MSP-EXP430 G2ET LaunchPad Development Kit	MSP-EXP430 G2ET	Texas Instruments	1	Obtained (already owned)
9	MSP430G2553 MCU	MSP430G2553IN20	Texas Instruments	1	2.95
10	HC-05 Bluetooth Module	HC-05	HiLetGo	2	12.59

11	Load Cell Weight Sensors	N/A	NEXTION	4	8.49
12	HX711 Amplifier AD Module	HX711	NEXTION	1	Included with load cells
13	LED Lights	N/A	EBOOT	100	6.55
14	Velostat	N/A	Adafruit	1	4.95
15	Copper Tape	N/A	LOVIMAG	1	10.99
16	Vibration Motors	N/A	XINYIYUAN	4	23.18
17	12V-12V Voltage Regulator	N/A	HOMELYLIFE	1	16.98
18	12V-3.3V Voltage Regulator	TPSM84624M OLR	Texas Instruments	1	5.35
19	5V-3.3V Voltage Regulator	TLV62090RG TR	Texas Instruments	2	2.62
Total Cost		\$422.12 (without housing systems included)			

Table 20. Total Cost Analysis at End of Senior Design 1

9.0 Team Collaboration

Teamwork was an essential part of this project. Without the use of online communication platforms, our collaboration and overall document would have suffered. Our team met virtually at least twice a week, typically on Mondays and Fridays. Our meeting would range anywhere from a quick check in to hour long discussions. The three main platforms that assisted us in completing this project were Discord, Zoom and Google Drive.

9.1 Discord

To be able to easily communicate at any time, a Discord server was created for our team. This platform allows for the creation of multiple text channels which helped us

organize our thoughts and notes into categories such as project ideas, meeting planning and next meeting goals. There is also a general text channel that is used most of the time to ask each other questions outside of our meetings and give updates throughout the week. Being able to set next meeting goals that we could all see and refer back to was very helpful for staying on track and making sure everyone had an assigned task to complete and discuss at the next meeting. Discord also has a voice chat feature which is how we would host most of our meetings.

9.2 Zoom

Zoom was used for video call meetings when we wanted to be able to share our screens with the team. This can be done on Discord but we ran into some issues a few times and would transition to a Zoom call.

9.3 Google Drive

The most important platform used to complete our project assignment was Google Drive. This platform allowed our team to create a shared folder to organize all our resources. The final paper was written in Google Docs because everyone can view and modify the document at any time and changes are saved automatically. It also has a comment feature in which team members can highlight a section and make reminders or ask questions for the person who wrote that section.

10.0 Appendices

This section is to contain a list of references used for the research and development of this project.

10.1 Appendix A: Image Permission Requests/Confirmations

This section contains a list of email screenshots either requesting permission for the use of certain images in this design document, or screenshots of granted permissions.

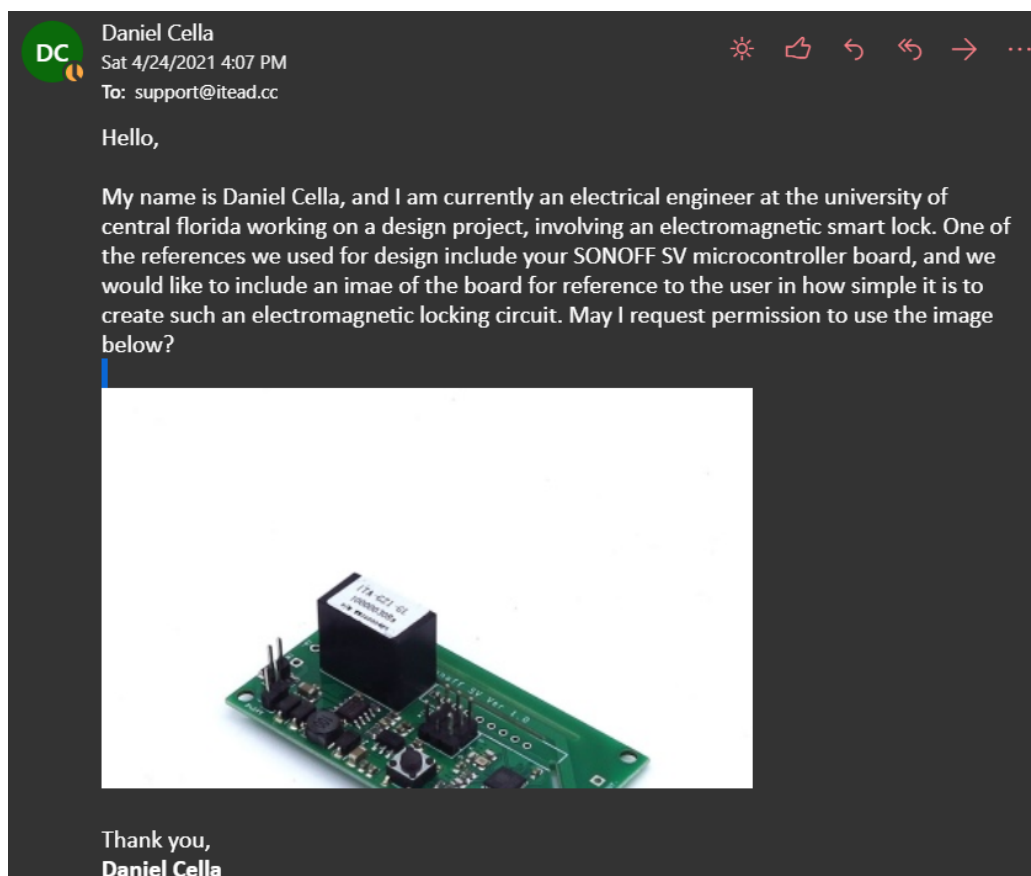

Figure 43. SONOFF SV Image Request

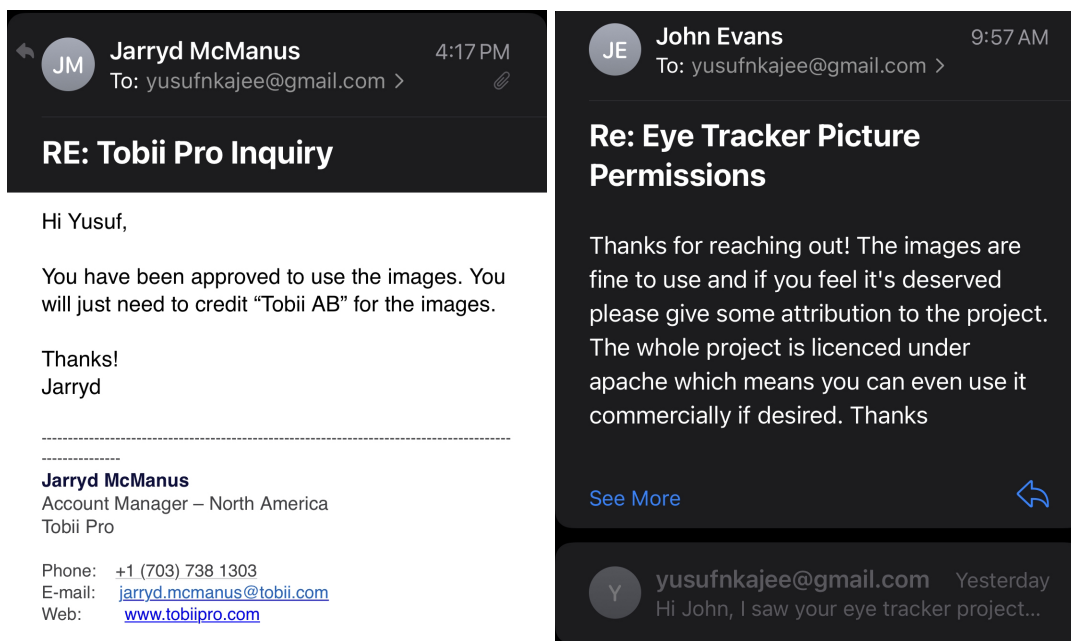

Figure 45. Tobi Image Request/Confirmation

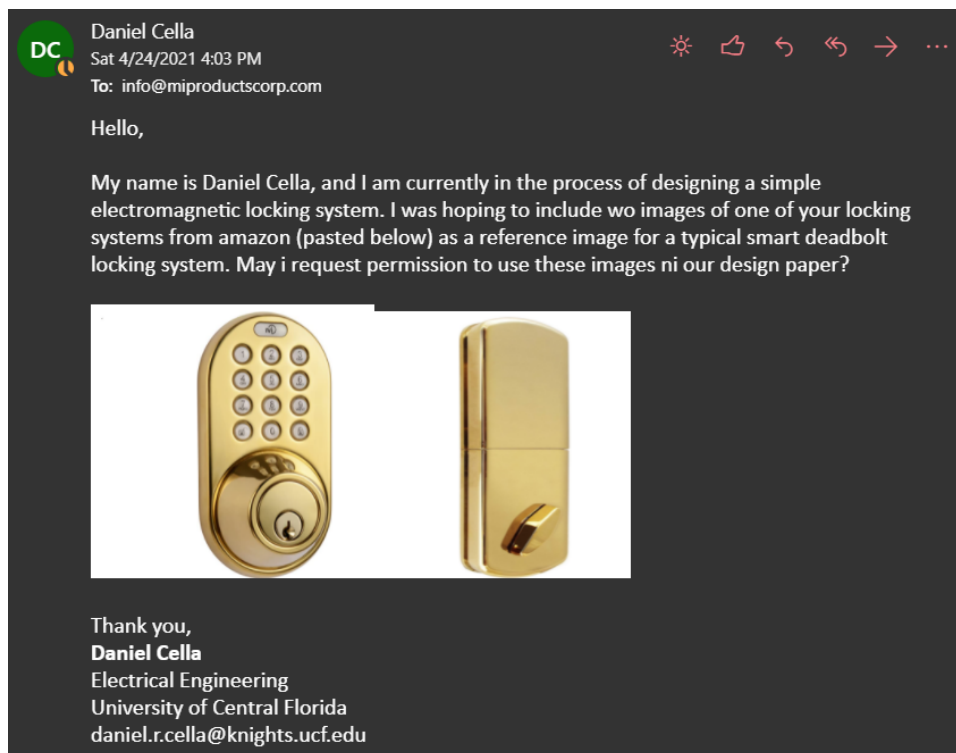

Figure 46. Milocks Image Request

Name

Daniel Cella

Phone

[Redacted]

Email

Daniel.r.cella@knights.ucf.edu

Comments

system for a design project. We would like to include a reference picture to the type of magnet we'd be implementing into our system, the Securitron SAM2 model to be exact, and we'd like to request permission to reproduce it in our paper

Submit

Figure 47. Locksmith Ledger International Image Request

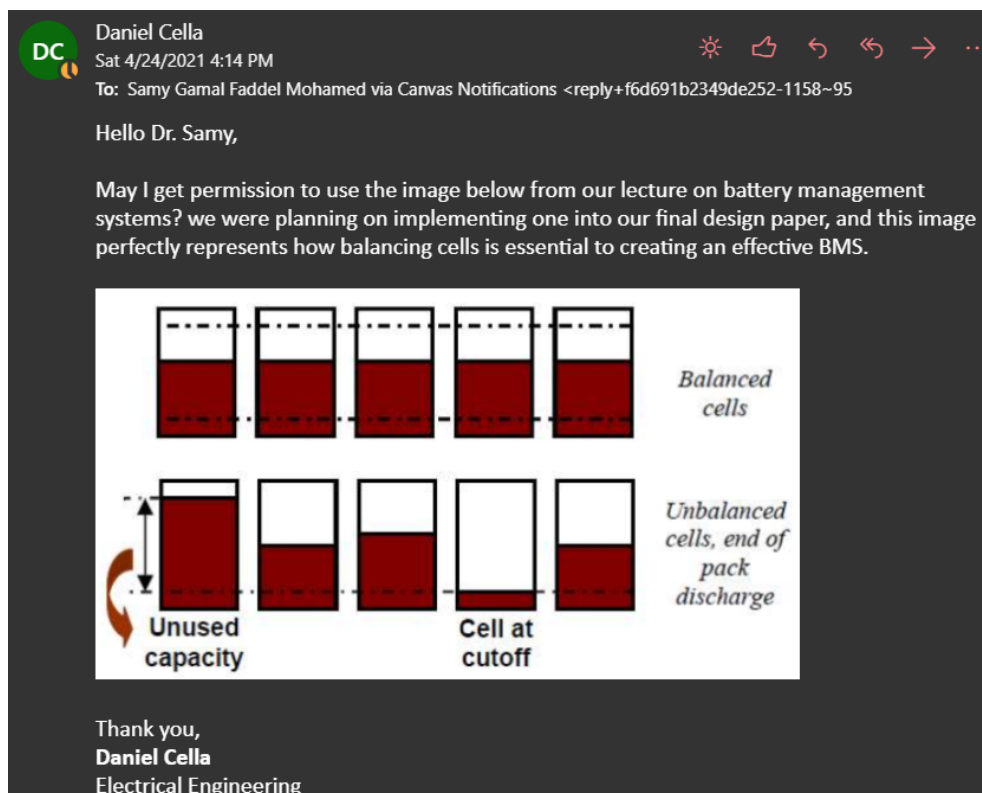

Figure 48. Battery Balancing Educational Image Request

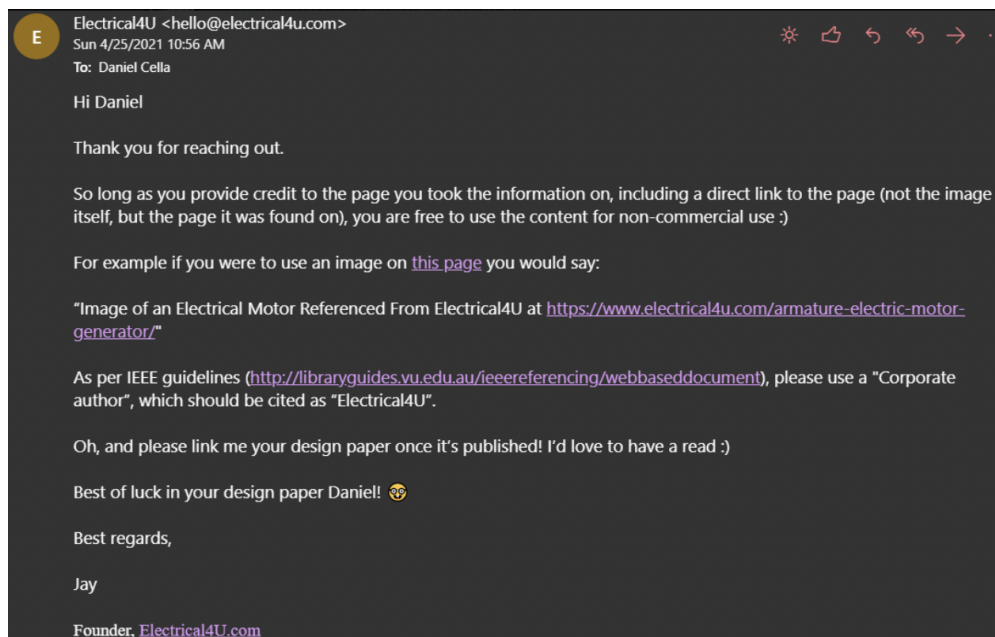

Figure 49. electrical4u.com Regulator Image Requests

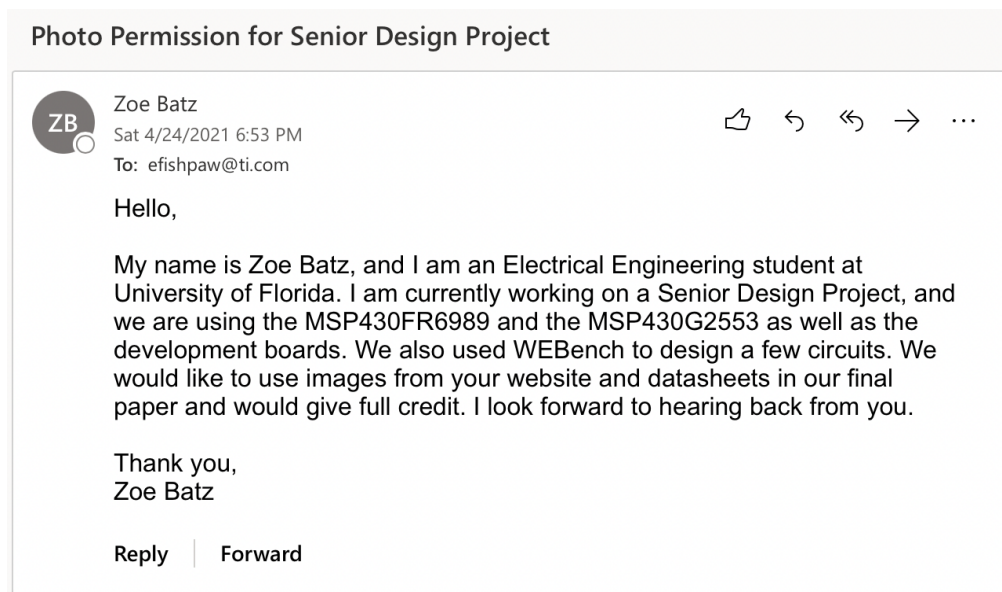



Figure 50. Texas Instruments Image Requests

 **Write to us:**

Your name

Your email

Subject

Message

Central Florida. I am working on a senior design project and will be using the HC-05 Bluetooth module. I was reaching out for permission to use images on your site regarding this product. I look forward to hearing back from you.

Captcha

7047

Submit

Figure 51. Bluetooth Module Image Requests

Product details inquiry from Amazon customer Mitchell Brown(Order: 111-0501992-1649060)

From: DIYmalls 04/12 17:28:08

Attachments :

1. 4pcs load cell 50kg+1pcs hx711 module.jpg
2. load cell size.jpg
3. no r3 connection.jpg
4. load cell connection.jpg
5. load cell wiring.jpg
6. hx711 connection.jpg

Hi Mitchell,
Thank you for confirming it with me.
You can use all images of the 4pcs load cell weight sensor.
Please check attachment.
Emma

Figure 52. Load Cell Weight Sensor Image Request Confirmation

10.1 Appendix B: References

Below is a list of the URLs used for research purposes in this project.

- [1] <https://patents.google.com/patent/US20030179073A1/en>
- [2] <https://hackaday.com/2018/05/05/low-cost-eye-tracking-with-webcams-and-open-source-software/>
- [3] <https://hackaday.io/project/153293/gallery#62dbf9b523b143ff1bfec1d964d9a38f>
- [4] <https://www.hackster.io/news/cheap-open-source-eye-tracking-you-can-build-yourself-7f4575d2d40f>
- [5] <https://gazerecorder.com/gazerecorder/>
- [6] <https://webgazer.cs.brown.edu/#>
- [7] https://www.researchgate.net/publication/220989434_Do-It-Yourself_Eye_Tracker_Low-Cost_Pupil-Based_Eye_Tracker_for_Computer_Graphics_Applications
- [8] <https://gaming.tobii.com/product/eye-tracker-5/#specs>
- [9] <https://www.locksmithledger.com/electronics-access-control/article/10856574/guide-to-electromagnetic-locks>
- [10] <https://patents.google.com/patent/US10515496B2/en?q=Electronic+Lock+System&oq=Electronic+Lock+System>
- [11] <https://patents.google.com/patent/US10127750B2/en?q=Electronic+Locking&oq=Electronic+Locking>
- [12] <https://www.doityourself.com/stry/how-a-deadbolt-works>
- [13] <https://www.autodesk.com/products/eagle/blog/wifi-vs-bluetooth-wireless-electronics-basics/>
- [14] <https://www.netguru.com/codestories/bluetooth-vs-wifi-comparison-for-the-iot-solutions>
- [15] <https://www.edgefxkits.com/blog/interfacing-hc-05-bluetooth-module-with-microcontroller/>
- [16] <https://core-electronics.com.au/tutorials/how-to-choose-a-bluetooth-module-for-your-project.html>
- [17] <https://www.youtube.com/watch?v=SLRYX879Py0>
- [18] https://batteryuniversity.com/learn/article/sharing_battery_knowledge
- [19] https://batteryuniversity.com/learn/article/charging_from_a_usb_port
- [20] <https://components101.com/articles/how-to-choose-the-right-microcontroller-for-your-project>
- [21] <https://circuitdigest.com/article/how-to-select-the-right-microcontroller-for-your-embedded-application>
- [22] <https://circuitdigest.com/article/how-to-select-the-right-microcontroller-for-your-embedded-application>

[23]

https://www.ti.com/lit/ug/slau772a/slau772a.pdf?ts=1614198796160&ref_url=https%253A%252F%252Fwww.google.com%252F

[24]

https://www.ti.com/lit/ds/symlink/msp430fr6989.pdf?ts=1614294882012&ref_url=https%253A%252F%252Fwww.ti.com%252Fproduct%252Fmsp430fr6989%253Futm_source%253Dgoogle%2526utm_medium%253Dcpc%2526utm_campaign%253Ddepd-null-null-GPN_EN-cpc-pf-google-wwe%2526utm_content%253DMSP430FR6989%2526ds_k%253D%257B_dssearchterm%257D%2526DCM%253Dyes%2526gclid%253DCj0KCQiAst2BBhDJARIsAGo2ldXWvEUda-6709re2S3nP6p6yYdB_GUeTVuEZ2feczMkyylsEKUMyRQaAi3KEALw_wcB%2526gclid%253Daw.ds

[25]

<https://www.nordicsemi.com/-/media/Software-and-other-downloads/Product-Briefs/old-versions/nRF52840PBv20.pdf?la=en&hash=516968A8D06D7F41C8B14B6639DD9E14099E2853>

[26] <https://lastminuteengineers.com/nrf24101-arduino-wireless-communication/>

[27]

<https://www.seeedstudio.com/blog/2019/09/25/uart-vs-i2c-vs-spi-communication-protocols-and-uses/>

[28]

https://www.ti.com/lit/ug/slau627a/slau627a.pdf?ts=1618227718070&ref_url=https%253A%252F%252Fwww.ti.com%252Ftool%252Fmsp-exp430fr6989

[29]

https://www.ti.com/lit/ug/slau627a/slau627a.pdf?ts=1615629127908&ref_url=https%253A%252F%252Fwww.google.com%252F

[30]

https://www.ti.com/lit/ug/slau772a/slau772a.pdf?ts=1618248163116&ref_url=https%253A%252F%252Fwww.ti.com%252Ftool%252Fmsp-exp430g2et%253Futm_source%253Dgoogle%2526utm_medium%253Dcpc%2526utm_campaign%253Ddepd-msp-430-prodfolderdynamic-cpc-pf-google-wwe%2526utm_content%253Dprodfolddynamic%2526ds_k%253DDYNAMIC%2BSEARCH%2BADSD%2526DCM%253Dyes%2526gclid%253DCj0KCQjw38-DBhDpARIsADJ3kjkGm_ydx5L_seBcu4yrfhrQO-JCNRDITEpQcWQtARVHu3rWkDxOvSsaAi40EALw_wcB%2526gclid%253Daw.ds

[31] <https://www.youtube.com/watch?v=rOwcxFERcvQ>

[32] <https://datasheets.raspberrypi.org/bcm2711/bcm2711-peripherals.pdf>

[33]

<https://www.raspberrypi.org/documentation/hardware/raspberrypi/frequency-management.md>

[34] <https://datasheets.raspberrypi.org/pico/pico-datasheet.pdf>

[35] <https://www.raspberrypi.org/documentation/rp2040/getting-started/>

[36] <https://datasheets.raspberrypi.org/rp2040/rp2040-datasheet.pdf>

[37] <https://www.link-labs.com/blog/bluetooth-vs-bluetooth-low-energy>

[38]

<https://www.seeedstudio.com/blog/2020/10/27/all-about-cpus-microprocessor-microcontroller-and-single-board-computer/>

[39] <https://www.electriciancourses4u.co.uk/useful-resources/ip-ratings-explained/>

[40] https://www.engineeringtoolbox.com/ip-ingress-protection-d_452.html

- [41] <https://www.coursera.org/lecture/battery-management-systems/1-4-4-what-are-cell-soc-and-battery-pack-soc-SZZJf>
- [42] <https://www.raspberrypi.org/documentation/hardware/raspberrypi/bcm2835/BCM2835-ARM-Peripherals.pdf>
- [43] <https://blog.matric.com/ipc-class-definitions-class-1-2-3-electronics>
- [44] <https://components101.com/wireless/hc-05-bluetooth-module>
- [45] <https://circuitdigest.com/microcontroller-projects/interfacing-hc-05-bluetooth-module-with-msp430-launchpad-to-control-an-led>
- [46] https://components101.com/asset/sites/default/files/component_datasheet/HC-05%20Datasheet.pdf
- [47] <https://www.electronicwings.com/ti-launchpad/hc-05-bluetooth-module-interfacing-with-msp-exp430g2-ti-launchpad>
- [48] <https://www.adafruit.com/product/2633>
- [49] <https://learn.adafruit.com/introducing-the-adafruit-bluefruit-spi-breakout/pinouts>
- [50] <https://www.adafruit.com/product/2479>
- [51] <https://learn.adafruit.com/introducing-the-adafruit-bluefruit-le-uart-friend/pinouts>
- [52] <https://components101.com/wireless/hm-10-bluetooth-module>
- [53] <https://www.electricaltechnology.org/2014/11/types-of-switches-electrical.html>
- [54] <https://electronics.howstuffworks.com/relay.htm>
- [55] <https://components.omron.com/relay-basics/basic#:~:text=%20The%20Three%20Actions%20of%20Electrical%20Relays%20.outputs%20with%20only%20one%20input%20.%20More%20>
- [56] https://www.epanorama.net/circuits/semiconductor_relays.html#:~:text=Solid%20state%20relay%20and%20semiconductor%20relay%20are%20both,switch%20electricity%20to%20a%20load%20in%20many%20applications.
- [57] <https://electronics.stackexchange.com/questions/401414/calculate-battery-state-of-charge-percentage>
- [58] <https://www.watelectrical.com/power-mosfet-basics-working-principle-applications/>
- [59] https://www.youtube.com/watch?v=GrvvkYTW_0k&t=399s
- [60] <https://modernsurvivalblog.com/alternative-energy/battery-state-of-charge-chart/>
- [61] <https://circuitdigest.com/electronic-circuits/simple-mosfet-switching-circuit-how-to-turn-on-turn-off-mosfets#:~:text=MOSFET%20Switching%20Circuit%20MOSFET%20is%20a%20transistor%20that,Semiconductor%20Field%20Effect%20Transistor%20C%20which%20has%20a%20gate.>
- [62] <https://www.ti.com/lit/an/snva558/snva558.pdf>

- [63] https://www.electronics-notes.com/articles/analogue_circuits/power-supply-electronics/linear-ps-u-shunt-regulator-circuit.php
- [64] <https://www.dimensionengineering.com/info/switching-regulators#:~:text=A%20switching%20regulator%20works%20by%20taking%20small%20chunks,the%20output%20%20%28hence%20the%20term%20%E2%80%9Cswitching%20regulator%E2%80%9D%29.>
- [65] <https://www.electrical4u.com/buck-converter-step-down-chopper/>
- [66] <https://www.electrical4u.com/boost-converter-step-up-chopper/>
- [67] https://www.digikey.com/en/products/detail/stmicroelectronics/L7805CV/585964?utm_adgroup=Supplier_STM&utm_source=bing&utm_medium=cpc&utm_campaign=EN_Product_SKU_MBR&utm_term=%2BI7805cv&utm_content=Supplier_STM&utm_id=bi_cmp-25179796_adg-2101804_405_ad-81295146303645_kwd-81295199128617:loc-190_dev-c_ext-_prd-&msclkid=cd208e0a7564168d4379ee76995baf25
- [68] https://www.youtube.com/watch?v=56p3_aORiJ0&list=LL&index=12&t=1063s
- [69] <https://www.youtube.com/watch?v=3PkpOeHTnfo&list=LL&index=10&t=131s>
- [70] <https://circuitdigest.com/electronic-circuits/simple-mosfet-switching-circuit-how-to-turn-on-turn-off-mosfets>
- [71] <https://webench.ti.com/power-designer/switching-regulator?update=1&powerSupply=0>
- [72] <https://www.precisionmicrodrives.com/vibration-motors/>
- [73] <https://www.precisionmicrodrives.com/vibration-motors/linear-resonant-actuators-lras/>
- [74] <https://www.precisionmicrodrives.com/vibration-motors/coin-vibration-motors/>
- [75] <https://www.precisionmicrodrives.com/vibration-motors/eccentric-rotating-mass-vibration-motors-erms/>
- [76] <https://www.youtube.com/watch?v=4JBShqUcaG4&t=196s>
- [77] https://www.youtube.com/watch?v=8SQOBF0_80Y&t=1s
- [78] <https://www.tekscan.com/flexiforce-load-force-sensors-and-systems>
- [79] <https://www.800loadcel.com/load-cell-and-strain-gauge-basics.html#:~:text=A%20strain%20gauge%20load%20cell%20is%20comprised%20of%20a%20solid,sturdy%20but%20also%20minimally%20elastic.>
- [80] <https://ieeexplore.ieee.org/document/8859679>
- [81] <https://ieeexplore.ieee.org/document/1016473>
- [82] <https://ieeexplore.ieee.org/document/9144691>
- [83] <https://ieeexplore.ieee.org/stamp/stamp.jsp?tp=&arnumber=7346375>
- [84] <https://ieeexplore.ieee.org/stamp/stamp.jsp?tp=&arnumber=8764712>
- [85] <https://standards.ieee.org/standard/1635-2018.html>
- [86] <https://ieeexplore.ieee.org/document/9363693/versions#versions>
- [87] <https://ieeexplore.ieee.org/document/26560>
- [88] <https://standards.ieee.org/standard/82079-1-2019.html>
- [89] <https://www.ipc.org/TOC/IPC-2221A.pdf>

[f=pd_di_sccai_3?pd_rd_w=TJCIF&pf_rd_p=c9443270-b914-4430-a90b-72e3e7e784e0&pf_rd_r=EG0GQP0S9RV7V0KWG1HE&pd_rd_r=d5a891ea-c2d9-47b9-9717-88f03cb04dcc&pd_rd_wg=zKIXZ&pd_rd_i=B07V8K6YZ6&psc=1](https://www.ti.com/lit/ds/symlink/tlv62090.pdf?ts=1619224721233)

[106] <https://www.ti.com/lit/ds/symlink/tlv62090.pdf?ts=1619224721233>

[107]

<https://www.ti.com/lit/ds/symlink/tpsm84624.pdf?HQS=dis-dk-null-digikeymode-dsf-pf-null-ww&ts=1619303257692>

[108] <https://datasheetspdf.com/pdf/842201/Aviasemiconductor/HX711/1>

[109]

https://www.amazon.com/gp/product/B07YHC8DNT/ref=ppx_yo_dt_b_asin_title_o01_s00?ie=UTF8&psc=1

[110]

https://www.amazon.com/gp/product/B071JKLFXX/ref=ppx_yo_dt_b_asin_title_o04_s00?ie=UTF8&psc=1

[111]

https://www.adafruit.com/product/1361?gclid=Cj0KCQjwyZmEBhCpARIsALizmnLfZG-kuq4R17owhrDefyM6MMd5T7_2w85UBxyGG8PxamHkEEESVv8aAt48EALw_wcB