

# Garbage & Recycle Automated Disposal (GRAD)

*Department of Electrical and Computer Engineering  
University of Central Florida  
Dr. Lei Wei  
Fall 2020*



## **Group B**

Sean Quinlan - Electrical Engineering  
Abdulsalam Khan - Computer Engineering  
Sadiyah Bhuria - Computer Engineering  
Heba Nassereddeen- Computer Engineering

## Table of Contents

1.0 Executive Summary .....	1
2.0 Project Description.....	3
2.1 Statement of Motivation.....	3
2.2 Initial Building Materials Guide/Plan .....	4
2.3 Deliverables & Requirement.....	4
2.3.1 Deliverables .....	4
2.3.2 Requirement Specifications .....	5
2.4 Block Diagram .....	5
2.5 House of Quality .....	7
3.0 Research of Technical Design .....	9
3.1 Related Projects.....	9
3.1.1 Smart Can .....	9
3.2 Relevant Technologies and Research.....	9
3.2.1 Photovoltaic Solar Cells .....	9
3.2.2 Voltage Regulators .....	10
3.2.3 Three vs. Four Wheel Drive Base .....	15
3.2.4 Types of DC Motors .....	16
3.3 Component & Part Comparison .....	18
3.3.1 Drive Systems .....	18
3.3.2 Selection of Garbage Bin.....	21
3.3.3 Selection of Swivel Caster Wheels.....	24
3.3.4 Motors.....	26
3.3.5 Printed Circuit Board.....	33
3.3.6 Power Supply.....	34
3.3.7 Batteries .....	37
3.3.8 Solar Panels .....	39
3.3.9 Voltage Regulator.....	41
3.3.10 PCB Design Software.....	42
3.3.11 PCB Manufacturers .....	43
3.3.12 Embedded Computer .....	44
3.3.13 Microcontroller Requirements.....	48
3.4 Possible Architectures and Related Diagrams .....	53

3.4.1 Communications .....	53
3.4.2 Path Planning.....	64
3.4.3 Selection of Sensors.....	66
3.4.4 Camera.....	70
3.5 Programming Architecture .....	76
3.5.1 Programming Languages .....	76
3.5.2 Integrated Development Environment Platform for Application .....	79
3.5.3 Stacks.....	84
3.6 Part Selection Summary .....	86
4.0 Applicable Standards & Realistic Design Constraints.....	88
4.1 Applicable Standards & Design Impact .....	88
4.1.1 IEEE Wireless Standards.....	88
4.1.2 Wi-Fi Standards .....	88
4.1.3 Printed Circuit Board Standards .....	90
4.1.4 Electrical Shock Standards .....	93
4.1.5 Battery Standards.....	93
4.1.6 Photovoltaic Battery Standards .....	93
4.1.7 Motor Standards .....	95
4.1.8 Power Supply Standards.....	96
4.1.9 Coding Standards.....	99
4.2 Realistic Design Constraints .....	101
4.2.1 Economic Constraints.....	101
4.2.2 Power Supply Constraints .....	101
4.2.3 PCB Constraints .....	101
4.2.4 Environmental Constraints .....	102
4.2.5 Social and Political Constraints.....	102
4.2.6 Ethical Constraints.....	103
4.2.7 Health and Safety Constraints .....	103
4.2.8 Time Constraints.....	104
4.2.9 Testing/Presentation Constraints .....	104
5.0 Project Hardware and Software Design.....	106
5.1 Physical Design.....	106

5.1.1 Drive Base Design Configuration.....	108
5.1.2 Motor Adjustment.....	109
5.2 Hardware Design and Power Flow.....	110
5.2.1 Power Supply & Voltage Regulation Design.....	111
5.3 Software Design.....	114
5.3.1 Software Logic Diagram.....	114
5.3.2 Application Overview.....	115
5.4 Microcontroller Design.....	117
5.4.1 DS3231 Real Time Clock Module.....	117
5.4.2 ESP8266-01 Wi-Fi Module.....	119
5.5 Line Following Algorithm.....	120
6.0 Design Testing and Implementation.....	121
6.1 Individual Systems Testing.....	121
6.1.1 Microcontroller Testing.....	121
6.1.2 Voltage and Breadboard Testing.....	122
6.1.3 Motor Testing.....	124
6.2 Proposed Schematic Implementation.....	124
6.3 Software Testing.....	128
7.1 Project and Finance Discussion.....	129
7.2 Project Milestones.....	130
7.3 Team Collaboration.....	132
8.0 Conclusion.....	133
9.0 References.....	134
Appendix: Copyright Permissions.....	141

## List of Figures

Figure 1: GRAD Bot Block Diagram .....	6
Figure 2: Photovoltaic Functionality .....	10
Figure 3: Series Voltage Regulator Topology .....	11
Figure 4: Shunt Voltage Regulator Topology.....	13
Figure 5: Buck Regulator Circuitry .....	14
Figure 6: Boost Regulator Circuitry .....	14
Figure 7: Three-Wheeled Drive controlled through angular velocities .....	15
Figure 8: Configuration of Brushless Motor [6].....	17
Figure 9: Diagram of a Gear Motor [7] .....	17
Figure 10: Standard Drive Base.....	18
Figure 11: Mecanum Drive Base .....	19
Figure 12: Track Drive Base.....	20
Figure 13: Blue Hawk Two-Wheeled Trash Can [9].....	22
Figure 14: Toter Two Wheeled Trash Can [10].....	23
Figure 15: Rubbermaid Four Wheeled Trash Can [11] .....	23
Figure 16: Conceptual diagram of a DC Motor [13] .....	27
Figure 17: Illustration of different forces acting.....	28
Figure 18: Illustration of forces to calculate Gradient Resistance.....	29
Figure 19: PCB Composition Diagram.....	34
Figure 20: Full Wave Bridge Rectifier Circuit With Output (Electronics Tutorials).....	35
Figure 21: Simple Solar Recharging Circuitry (No Voltage Regulation).....	36
Figure 22: Solar Panel Material Diagram .....	39
Figure 23: Solar Panel Types (EnergySage.com).....	40
Figure 24: The Raspberry Pi 4.....	46
Figure 25: NVIDIA Jetson Nano, Licensed under CC 2.0 .....	46
Figure 26: ODROID-XU4. Pending approval .....	47
Figure 27: Arduino Mega 2650. Reprinted with permission from www.arduino.cc.....	49
Figure 28: TI MSP430FR6989 .....	49
Figure 29: GeekNET ESP32. Licensed under CC0 1.0 .....	50
Figure 30: The iRobot Create 2. Reprinted with permission from iRobot .....	52
Figure 31: Breakdown of IEEE 802.11 Common Wi-Fi Standards .....	54
Figure 32: Wi-Fi Connection Process. Pending Approval.....	55
Figure 33: ESP8266. Licensed under CC by 2.0 .....	56
Figure 34: CC3120 TI Processor. Reprinted with Permission from.....	57
Figure 35: NVIDIA Jetson Nano Wi-Fi Adapter.....	58
Figure 36: FHSS Example in the ISM Band.....	59
Figure 37: Bluetooth Connection Process.....	62
Figure 38: (A) Environment with obstacles (B) One possible path from start to goal ....	64
Figure 39: IR transmitters and receivers in line following. ....	65
Figure 40: HC SR04 ultrasonic sensor. Reprinted with permission from thepihut.com ..	68
Figure 41: Working principle of the ultrasonic sensor. Pending Approval .....	69

Figure 42: Raspberry Pi Camera Module V2. ....	70
Figure 43: Raspberry Pi NoIR Camera Module V2.....	71
Figure 44: Front View of Pixy2CMUcam5 .....	72
Figure 45: Back View of Pixy2CMUcam5.....	72
Figure 46: Raspberry Pi Night Vision Camera with Fisheye 160 ° Lens. ....	73
Figure 47: Logitech HD Webcam C525. Pending Approval.....	74
Figure 48: Intel® RealSense™ D415. Reprinted with permission of sparkfun.com .....	74
Figure 49: Use Case Diagram for Mobile App.....	78
Figure 50: Printed Circuit Board Standards from IPC.....	92
Figure 51: Classification of Motor System from IEC [85].....	95
Figure 52: Visual depicting GRAD Holding Body & Standard Drive .....	106
Figure 53: Side view drawing Illustrating Compartment A & B.....	107
Figure 54: Visual depicting solar panel at the top side.....	108
Figure 55: Conceptual placement of Motors .....	109
Figure 56: Power Flow Design .....	110
Figure 57: Solar Panel and Battery Voltage Regulator Circuit with LM317 .....	111
Figure 58: Battery to Microcontroller Schematic .....	112
Figure 59: Voltage Regulation from 5V to 3.3 V .....	113
Figure 60: Software Logic Diagram .....	114
Figure 61: Login and Register page of the GRAD mobile application .....	115
Figure 62: Home Page and Schedule Time page of the GRAD mobile application.....	116
Figure 63: Arduino Mega to DS3231 Connection.....	117
Figure 64: Arduino Serial Monitor .....	118
Figure 65: ESP8266-01 and Arduino connection. Reprinted with permission.....	119
Figure 66: Logic for line following robots. ....	120
Figure 67: Output of i2c_scanner Program.....	121
Figure 68: Voltage Testing of the Battery .....	122
Figure 69: Solar Panel Voltage Testing .....	122
Figure 70: Voltage Testing of the Voltage Regulation Output of Solar Input.....	123
Figure 71: Voltage Regulation from Solar to Battery.....	123
Figure 72: Electrical Schematic into Subsystem .....	124
Figure 73: Voltage Regulation Circuitry, Overall Schematic Part 1 .....	125
Figure 74: Motor Control, Overall Schematic Part 2.....	126
Figure 75: Microcontroller Circuitry, Overall Schematic Part 3 .....	127
Figure 76: EnergySage Image Copyright Permission.....	141
Figure 77: Electrical4U Image Copyright Permission.....	141
Figure 78: IPC Image Copyright Permission.....	142
Figure 79: Sparkfun Image Copyright Permission .....	142
Figure 80: Electronic Tutorials Copyright Permission .....	143
Figure 81: DoITPoMS Image Copyright Permission .....	143
Figure 82: Solar Gain Copyright Permission.....	144
Figure 83: Raspberry PI Image Copyright Permission.....	144
Figure 84: Arduino Copyright Permission.....	145

Figure 85: iRobot Copyright Permissions.....	145
Figure 86: Endeavor Media/Microwaves&RF Image Copyright Permission.....	146
Figure 87: Cisco Meraki Image Permission.....	146
Figure 88: Texas Instruments Copyright Permission.....	147
Figure 89: Geekwork Image Copyright Permission .....	147
Figure 90: Rohde & Schwarz Copyright Permission.....	148
Figure 91: ShareTechnote Image Permission .....	148
Figure 92: Circuit Digest Copyright Permission .....	149
Figure 93: ElProCus Copyright Permission.....	149
Figure 94: Instructables Image Copyright Permission.....	150
Figure 95: How To Mechatronics Copyright Permission .....	151
Figure 96: Pi Hut Image Copyright Permission.....	152
Figure 97: Pi Shop Image Copyright Permission .....	152
Figure 98: Diagram of Gear Motor Copyright Permission.....	153
Figure 99: Classification of Motor System from IEC Copyright Permission.....	153

## List of Tables

Table 1: Project Selection Matrix .....	3
Table 2: Deliverable Table.....	4
Table 3: Requirement Specification Table .....	5
Table 4: House of Quality.....	8
Table 5: Comparison of Drive Systems .....	21
Table 6: Comparison of selected Trash Cans .....	24
Table 7: Comparison of Wheel Selection .....	26
Table 8: Selection of Motors.....	32
Table 9: Battery Analysis.....	38
Table 10: Voltage Regulator Analysis .....	42
Table 11: PCB Design Software Analysis .....	43
Table 12: PCB Manufacture Analysis .....	44
Table 13: Comparison of Embedded Computers.....	47
Table 14: Comparison of Microcontrollers.....	51
Table 15: Comparison of Bluetooth Power Classes .....	60
Table 16: Wireless Communication Comparison .....	63
Table 17: Comparison of Sensors [54] .....	69
Table 18: Camera Comparison .....	75
Table 19: Mobile Framework/ IDE Comparison .....	83
Table 20: Stacks Comparison .....	86
Table 21: Microcontroller and Modules Selection .....	87
Table 22: Power Supply Selection.....	87
Table 23: Sensor Selection.....	87
Table 24: Drive System Selection.....	87
Table 25: Voltage Classification.....	97
Table 26: Power Supply Classifications .....	98
Table 27: Pin Connection.....	126
Table 28: Project Budget .....	129
Table 29: Project Audit.....	129
Table 30: Senior Design I Project Milestone .....	130
Table 31: Senior Design II Project Milestone.....	131



## 1.0 Executive Summary

Taking the garbage and recycling cans to the curb can be easily forgotten during a busy schedule or when rushing to work in the mornings. For those with physical constraints, it can be demanding to accomplish such a task. Especially for vacation rental properties where guests forget to take out the trash/recycle bins to the curb on the correct schedule, and the pile-up of garbage creates extraneous work for the property manager. This project aims to eliminate the physical demands, incorporate ease, and facilitate efficiency by providing an automated controllable system to schedule trash bin curbside placement.

The GRAD requires path planning through line following. Implementing this element to the device ensures accurate collector placement and curbside positioning for collection. This would allow waste management to just pick and empty the trash can easily and would make it much faster as the trash can would be positioned. This smart trash system will allow the user to interact with the robot through an app from their phone. Two of the main features in the app include notifying the user if the trash can is full and allowing the user to drive the smart trash can to the curb. In addition, the user will be able to create a schedule depending on when their waste management picks up the trash, and the smart trash can will drive itself to the curb based on that schedule.

GRAD will be integrated into the garbage collectors. Due to modern environmental efforts, implementing solar panels into GRAD allows the decreased electricity usage from the home, and becomes self-operated. They will not require the user to have to plug the GRAD system in and out from an electrical outlet. This will allow the robot more independence and further fulfills the decreased user interaction with the robot. If the user forgets to plug in the robot or unplug GRAD, it would be unable to take the trash to the curb. Therefore, integrating a rechargeable battery alongside a solar system will allow for GRAD to charge during the day and implement curbside placement at any time. Monocrystalline Solar Panels and Thin Film Solar Cells seem to be the best choice for efficiency and for the project. Polycrystalline solar cells also seem to be reasonably priced. Further research will take place for the accurate determination of the solar-type. The battery will also have to be sufficient to support the GRAD system motors as well as the solar panel.

Implementing this system for public use would require the robots to be accurate, easy to maintain for the user (however maintenance from the company can be required). A mobile app will be implemented for user-friendly notifications, trash bin location, and waste management. Due to the fact of senior design, the project design, prototyping, testing, and final production will require an increased cost. As shown in Table 2, the cost for our model is set to be below \$600 yet if ever moved to production, this cost would have to decrease to maximize profit. Trash cans usually weigh about 25lbs and the goal is to keep the total weight (before accepting waste) to below 70lbs after implementing the device into the trash can. The GRAD robot will be able to carry a minimum of 20lbs of waste within the bin. Whenever the GRAD system determines when it should send a notification to the user (such as Trash picked up and GRAD successfully returned to the station), the user should be notified within less than two minutes after the notification has left from the robot.

The GRAD system will have an ultrasonic level sensor that will detect if the trashcan is 90% full. Once the trash can level is full, the data will be sent to the microcontroller and then the microcontroller will process the data and through the help of the Bluetooth module, it will send the data and notification to the app. The app will simply display the amount of trash in the trash can (measured by the percentage of the bin that is full) and it will also notify the user to empty the trash can if the weight or volume exceeds the specified amount. The user can also specify a weekly schedule for the GRAD system to specify when they want the garbage bin to be at the curb. For instance, if the trash day is every Tuesday and Thursday at 8:00 am, the user can set the arrival time for the garbage bin to match that time. The app will be flexible, so if trash day changes the user can update the schedule to reflect the new time at which the garbage bin needs to be at the curb. The user will also be able to cancel any scheduled times, in addition to being able to modify the dates and times the trash day. Also, the user will have the option to let the outdoor garbage bin to drive once it gets full as the user will be notified.

For the GRAD system to work properly, the user should also enter the location where they want the garbage bin to drive itself. Once the user sets the schedule for the GRAD system and establishes the destination location, the trash can will follow the appropriate directions to drive itself to the curb. A path planning algorithm will be required to navigate the trash bin from its starting position to the destination position. The microcontroller will transmit clock signals to the navigation software so that the GRAD system can operate in real-time.

The microcontroller that will be chosen for the GRAD system will most likely be an Arduino board. It should have enough I/O pins to satisfy the required connections that must be made to the motors, power source, sensors, and external clock. We will most likely utilize Python to implement the GRAD system's schedule planning algorithm, the final decision regarding which microcontroller and programming language to use will be made after conducting more research.

Besides programming the microcontroller, part of the research will focus on the software for the development of the phone application to be utilized by the user. The phone application will be integrated with the GRAD system to communicate over Bluetooth to send/receive signals. The application will be built using Android-based technologies including MERN stack due to the abundance of resources available online.

Due to all the capabilities for implementation and with a focus on the technical aspect of electrical engineering and autonomous drive system, this specific prototype will not deal with the factors of weather. Further research and implementation of weather protective measures can be implemented in another project. Due to technological advancements in the waste collection industry, the project will be implemented to include minimal device protection. The device components will be separated from waste, however with less human interaction and a more robotic type of trash collection, implementing this project into the future would allow less harsh movement of the trash bins. As previously stated, GRAD will be solar-powered, unlike its competitors saving money on the electric bill while staying environmentally friendly.

## 2.0 Project Description

### 2.1 Statement of Motivation

Before settling on the GRAD project, a few other project ideas were considered. Since our team consists of both computer engineers and electrical engineers, it was highly desirable to choose a project with equal amounts of hardware and software.

	Practicality	Difficulty	Cost	Interest
<b>Garbage and Recycle Automated Disposal Bot</b>	4	4	3	5
<b>Indoor Trash Collecting Robot</b>	3	4	3	2
<b>Automated Transportation System for Garbage Bins</b>	3	5	4	3
<b>Smart Shower</b>	2	5	4	3
<b>Smart Pet Feeder</b>	5	1	3	3

*Table 1: Project Selection Matrix*

As shown in Table 1, the practicality, difficulty, cost, and interest of five different project ideas were judged and carefully analyzed before making a final decision. As a team, we assigned a number 1 - 5 (with 1 being the lowest, and 5 being the highest) to our perceived values of each specification. We initially considered building a transport system for garbage bins rather than making the garbage bin itself smart- however, the difficulty of creating a mechanical body that is capable of lifting heavy weights made this idea undesirable, since our team does not have the same expertise as mechanical engineers regarding dynamics and rigid body motion. We also considered an alternative indoor robot that would navigate to the user upon command, however, this option did not interest all members since it would have leaned heavily towards software. GRAD was born out of these two ideas, it was the ideal middle-ground project that interested both the electrical and computer engineers on the team, and it combined elements that we liked (for example, implementing solar power into our design and path planning algorithms) while also eliminating difficult, unpractical elements (notably, the mechanical arm that is supposed to lift the heavyweight of a full garbage bin). Although a transport system would have been more scalable since it could be used to carry both recycle bins and garbage bins, it was deemed too impractical due to the mechanical aspects required.

The team also considered projects unrelated to garbage disposal: for instance, a smart shower system with features such as connecting to the user's internet to display water pattern usage, the ability to schedule showers ahead of time (which can optionally be accomplished by voice assistants such as Alexa), and precise control of temperature. Although everyone loved the smart shower idea, it seemed highly impractical since none of us had experience in controlling the flow of water through hardware, plus it would be difficult to test since that would require tapping into an already existing bathtub and shower. The last project under consideration was an RFID based smart pet feeder, which

automatically disposes the correct food to each animal in a household. Although this project is highly scalable and seemed the most practical to build, the team was not too interested in it since none of us are pet owners. After considering the practicality, difficulty, cost, and interest of all five options, it was decided that the GRAD project would be the most ideal option since it scored the highest across all the categories.

## 2.2 Initial Building Materials Guide/Plan

1. Solar Panel, Rechargeable Battery and Diodes for Power Supply. The solar panel and battery should allow the robot to take itself from placement to curb and back at least once per day.
2. Three or four Wheels
  - a. Use garbage can wheels with the addition of guide wheels in the front of the trash can.
3. Microcontroller and PCB to autonomously run the robot and control its electrical components
4. Phone app to schedule days/time for trash/recycle pickup
  - a. Bluetooth or Wi-Fi Module to connect with the phone using Bluetooth or across the home network
  - b. Implement two options: Scheduling and User Command
5. Two IR sensors used to implement line following
  - a. The goal is to be with five feet from accurate placement using line following
6. 1 Ultrasonic sensor for Trash monitoring.
  - a. Used to measure the capacity of the GRAD
  - b. Useful for waste management

## 2.3 Deliverables & Requirement

### 2.3.1 Deliverables

Requirement	Deliverable Description
GRAD System Movement Accuracy	The GRAD system should end up 5 feet from intended goal.
Solar Charging	Solar Panel Charges the Battery
Notification Optimization	Notification Latency: GRAD shall implement movement to the desired goal within two minutes of user implementing a desired action within the provided app (ex. when the user presses the button for the system to go to the curb, it should act within 2 minutes)

Table 2: Deliverable Table

### 2.3.2 Requirement Specifications

Requirement ID	Description
RS - 01	The robot shall have enough energy storage to hold at least 100Wh and solar to generate the battery daily dependent upon weather conditions.
RS - 02	GRAD will use a 12V Solar Panel System.
RS - 03	Notification Latency: User shall be notified within two minutes if the robot trash can tip over.
RS - 04	The phone application shall allow the user to schedule the GRAD bot for day and time it will drive to the curb.
RS - 05	The phone application shall notify the user once the trash is picked up within two minutes.
RS - 06	The phone application shall notify the user once the GRAD system has placed itself back to the user's desired location within two minutes.
RS - 07	Trash Robot Placement on the curb and on return will be within five feet of the desired location.
RS - 08	Trash can robot hold at least twenty pounds of waste.
RS - 09	Trashcan robot will work on a performance of 85% no obstacle collision.
RS - 10	GRAD system shall wait 10 seconds before continuing if stopped by an external object.
RS - 11	GRAD system shall stop a minimum of 6" from an obstacle.
RS - 12	GRAD trash storage bin shall be split into two bins (recycle & waste)
RS - 13	GRAD system shall have two motors.
RS - 14	GRAD shall traverse a maximum distance 500 feet from original placement location
RS - 15	GRAD System shall have two still location finders for robot destination planning

*Table 3: Requirement Specification Table*

### 2.4 Block Diagram

The block diagram in Figure 1 shows a high-level overview of the major components of the GRAD system. The GRAD system is divided into seven smaller subsystem blocks namely: Power System, Solar System, Drive System, Sensor system, Communication system, Software system, and lastly the Main Control system. Each of the system blocks is

assigned to a System Lead as if in the real engineering world who team members are based on their knowledge and expertise.

## Garbage & Recycle Disposal (GRAD) Bot

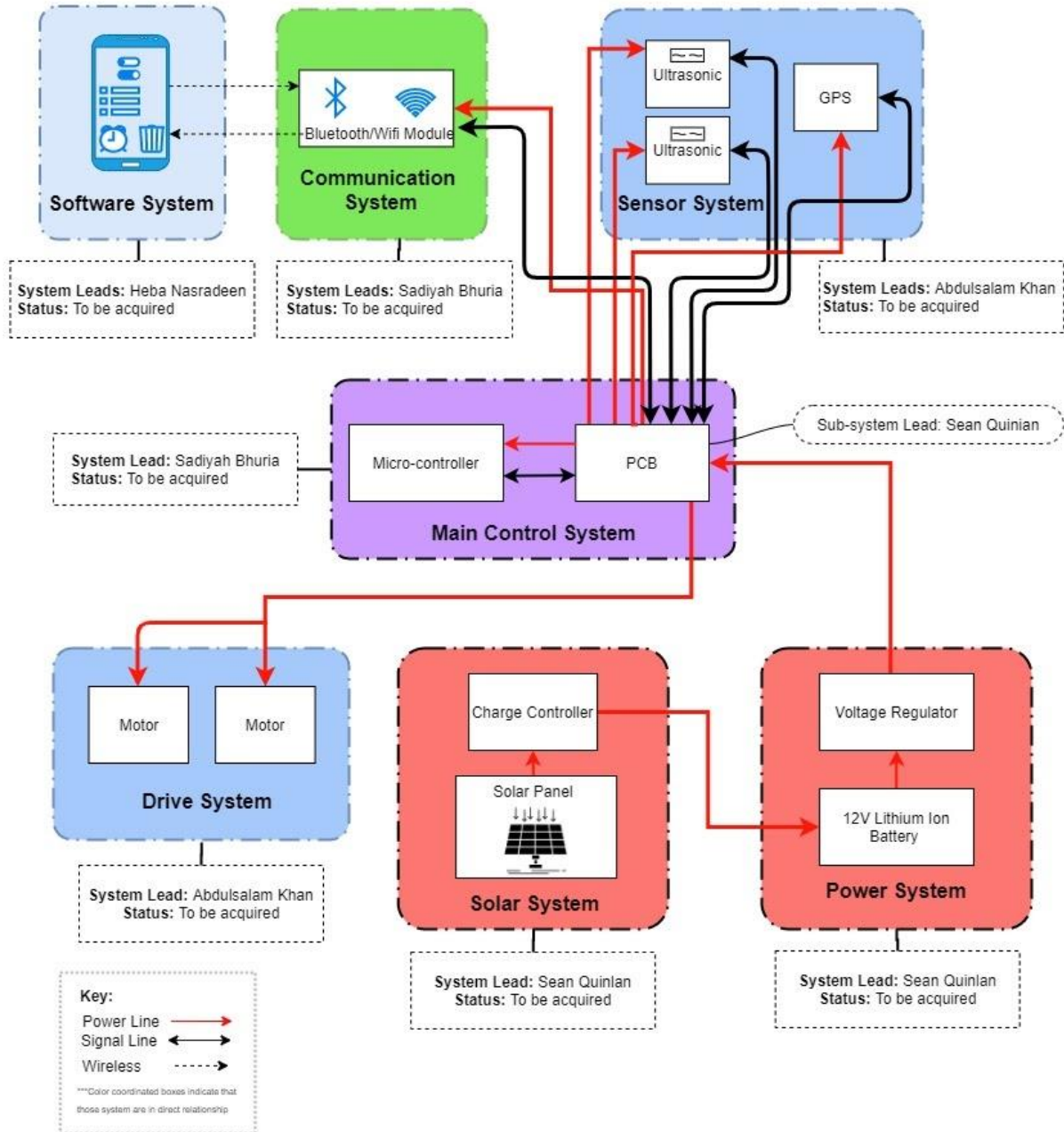


Figure 1: GRAD Bot Block Diagram

## 2.5 House of Quality

The house of quality is useful for defining and analyzing how the project can become more efficient in the desired attributes and reduce those that are not as significant. Table 4 is the Trade-off Matrix, or the House of Quality, for the Garbage Automated System. The table is comprised of positive and negative correlations with the increase or decrease of a requirement. The left side of the table labeled “Target”, shows the requirements that customers would consider for buying product. The blue section in the table depicts the engineering requirements/ trade-offs for which the team will have to achieve and execute upon the final product that will be built. The arrows assist in relating the correlation of requirements and the objectives. At the top of the “house” positives and negatives are displayed to show how each is affected by the other requirements.

Implementing a house of quality in the project assists in creating engineering requirements as well as a table for deliverables. When the team is designing, developing, prototyping and constructing the GRAD system, the house of quality matrix is useful to have at hand for the team to refer to. This can be useful when designing a system because increasing the efficiency of the system could easily increase the price of the system or changing the power source of the system could make an overall change to the efficiency or functionality of the system. This table assists the team in assessing positive and negative correlations in terms of the engineering and marketing requirements. This could assist in terms of unforeseen circumstances in design and functioning of the system, as if certain components must be interchanged then the overall correlations and relations could be affected across the system

The description of the arrows is shown in the Legend section.

### **Legend**

- ↑ = Positive correlation      ↑↑ = Strong positive correlation
- ↓ = Negative correlation      ↓↓ = Strong negative correlation
- + = Positive Polarity Increasing the Requirement
- = Negative Polarity Decreasing the Requirement

		Column #						
		1	2	3	4	5	6	7
Direction of Improvement		+	+	+	+	-	-	-
Maximum Relationship	Engineering Requirements	Efficiency	Power Usage	Control	Accuracy	Cost	Weight	Dimension
	Target							
+	Efficiency		↑↑	↑↑		↓↓	↑	↑
+	Durability	↓↓				↓↓	↑	↓↓
-	Dimension	↓				↓		
+	User-Friendly			↑↑		↓↓	↑	
+	Accuracy		↑	↑↑		↓↓		
-	Maintenance	↓		↓	↓↓	↓↓		↓
		Solar Only	100 Wh/day	85% Incident Free	5 Feet From Destination	<\$600	70lbs	6" Extended Build From Bin

Table 4: House of Quality



## **3.0 Research of Technical Design**

### **3.1 Related Projects**

#### **3.1.1 Smart Can**

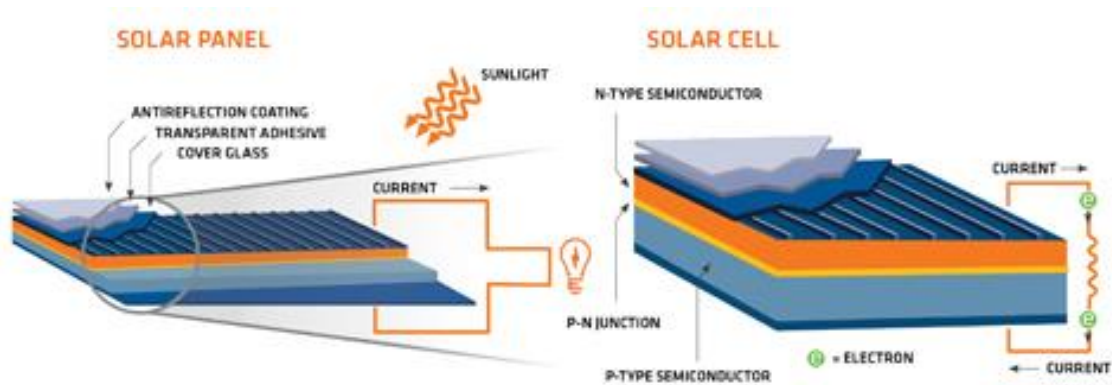
Smart garbage curbside robots are not actually on the market currently and are still in research and prototyping. These robots seem to offer limited functionality as the user has little capabilities and provides very little information that would be beneficial to the user. The robot will be able to report on the app the location and the actions it is taking. The Smart Can is a product by the company Rezzi that is currently being developed to go to market. The Smart Can is an automatic outdoor curbside trashcan system, that is independent of the garbage can, which will latch on the trash can. This system must be purchased for each garbage can and assembled on to it. There is no exact description on the device charging capabilities, its complete user capabilities (other than a mobile app which shows you where it is in terms of the driveway and scheduling of the device), and special features.

The goal of the GRAD system is to implement all the devices into a trashcan, which would require no assembly for the user. This will require less mechanical research and implementation for Group B and more time to focus on the electrical aspects and components of the system. However, GRAD goes a step further by implementing technologies that ensure the system is unique. The system implements line following, in combination with obstacle avoidance, to ensure proper and accurate movement of the system. The GRAD system will also detect the weight amount every time the trash or recycle is disposed, keeping track of disposal and recycling amount. Implementing this will help users become more environmentally friendly, as they become aware of how much waste they produce compared to recycling. As previously stated, GRAD will be solar-powered, unlike its competitors saving money on the electric bill while staying environmentally friendly.

### **3.2 Relevant Technologies and Research**

#### **3.2.1 Photovoltaic Solar Cells**

A photovoltaic solar cell is a type of device that turns light into electrical energy. These cells are composed of a semiconductor material and some type of insulation. Photovoltaic cell semiconductor material absorbs photons of light, which are emitted from the sun, which converts the light energy into an electrical energy. Each solar cell, which makes up the array, is made of wafers that are assembled into columns and rows. Each cell is connected using a metal. The metal between cells accumulate this energy and transfer it to the desired load. Below is a visual, Figure 2, showing how the solar cells gather the sun's energy and how each cell is incorporated into an array for generation [1].



*Figure 2: Photovoltaic Functionality*

The solar cells can be produced using many types of materials. The common types of photovoltaic systems are monocrystalline and polycrystalline, which are both silicon based, as well as thin-film, which are usually composed of either cadmium telluride or copper indium gallium diselenide. Organic photovoltaics are also beginning to be developed; however, these are not considered in GRAD system design. The silicon solar cells are considered to be low cost and highly efficient with a longer lifespan than other solar cells.

Photovoltaics are mainly used for powering homes and the electrical grid. However, recently they have started to be incorporated into everyday technologies and systems. Incorporating solar technologies into the GRAD system will allow the user more convenience in powering the GRAD system, as the system is less reliant upon wall outlets meaning no cables. While implementing solar is also convenient, “green energy” is an increasingly popular subject in today’s society and implementing these “greener” technologies into new products is essential for future environmental protection.

### **3.2.2 Voltage Regulators**

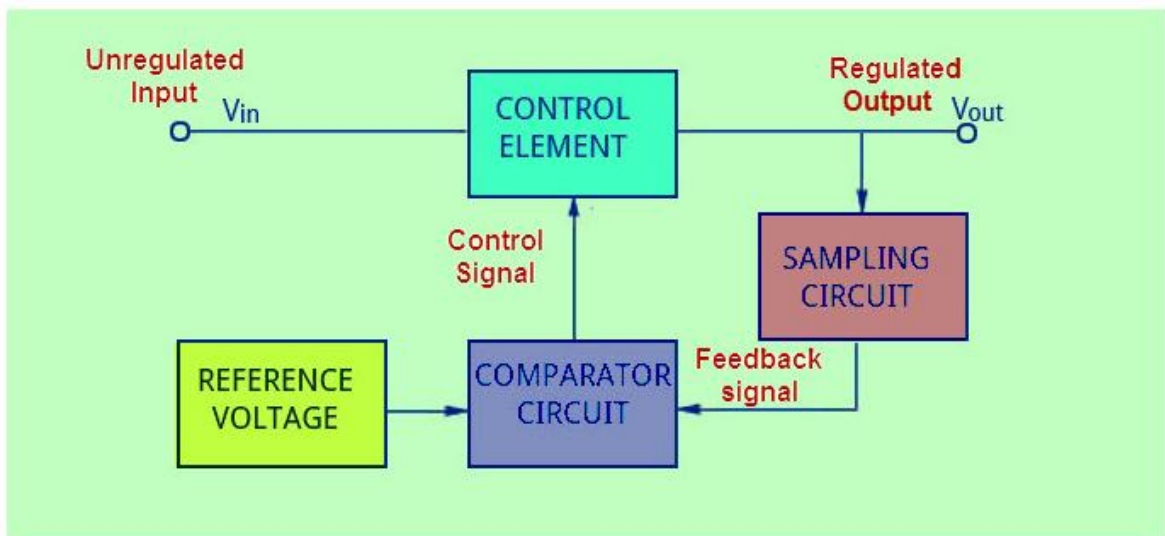
Voltage regulation within the PCB is required to ensure each component works accurately. Many systems and components of the GRAD system have different operating voltage ranges, as many sensors have a 3-5V operating range, whereas the battery and solar panel that is implemented is rated for 12V. Voltage regulation is required to ensure accuracy power flow within the system and ensure each system operates at the correct voltage level. Since the solar panel, battery and circuit run on DC voltage only DC to DC voltage regulation will be required. Within the PCB the voltage will have to be regulated for charging of the battery from the solar panel and then the battery will have to be regulated to operate the system. There are many different voltage regulators that can be used for different applications. Voltage regulators are integrated circuits that ensure proper voltage levels for a system. They work by keeping a set output voltage based upon a set input voltage range. The input to the regulators varies, however the purpose of this device is to ensure accurate and reliable output voltage for the desired system [97].

## Linear Voltage Regulator

Linear voltage regulators are step down converters (decrease the voltage) through a resistive feedback loop. They use either a BJT or a MOSFET in combination with an active high gain amplifier to achieve this. The purpose of this regulator is to maintain a constant output voltage, which is achieved by comparing the output and input voltage. Linear voltage regulators tend to be cheap, simple, quick to voltage change and little noise. However, they are inefficient as they produce heat. There are many types of linear voltage regulators to consider however they can be split into Series and Shunt regulators based upon how the load is connected [2].

### Series Voltage Regulator

Series voltage regulators place the variable controllable element in series with the load. The controllable element resistance changes therefore proportionally changing the voltage across that element. When this element's voltage is affected, then the output voltage on the load is changed according to the controllable element change (as the input voltage remains the same). Below is a visual of a series linear voltage regulator, Figure 3.



*Figure 3: Series Voltage Regulator Topology*

There are 3 basic series voltage regulators that are used: Standard Regulator, Low Dropout Regulator (LDO), and Quasi LDO Regulator.

### Standard

The first Linear Regulator is the Standard Linear Regulator sometimes called a NPN Darlington, since it uses the NPN Darlington configuration in the pass device. The transistor in this circuit requires a minimum voltage for operation:

$$V_D(\min) = 2V_{BE} + V_{CE}$$

The minimum input voltage to this regulator is in the range between 2.5-3V to ensure proper functionality. The dropout voltage will be somewhere between 1.5-2.2V for this type of voltage regulation circuit and the voltage across the regulated circuit tends to be about 3V. This regulator compared to the other 3 is best for AC powered applications. This system tends to be best for when the voltage difference across regulation tends to be higher than 3V [3].

### **Low Drop-Out Regulator**

The next linear voltage regulator is a Low Drop-Out regulator which is composed of a single PNP transistor, to which the voltage across the transistor must be

$$V_D(\min) = V_{CE}$$

The dropout voltage of the LDO regulator tends to be in the range between 0.6-0.8V, hence the term Low Drop-Out Voltage Regulator. Then tend to be used in battery powered systems implementing cost-savings. However, LDO regulators tend to be used in low voltage scenarios. LDO regulators tend to have a lower efficiency amount due to the heat that is produced from the system. The efficiency of an LDO regulator can be calculated through the input and output voltage, along with the output and the quiescent current in the below formula:

$$\text{Efficiency} = \frac{I_o V_o}{(I_o + I_q) V_i} \times 100$$

### **Quasi Low Drop-Out Regulator**

The last linear voltage regulator to be compared is the Quasi Low Drop-out regulator which is an alteration of the standard regulator. This regulator has a voltage across it:

$$V_D(\min) = 2V_{BE} + V_{CE}$$

This option is a middle ground between the LDO and the standard as the rated dropout voltage is 1.5V [3].

### **Shunt Regulators**

Shunt regulators are linear voltage regulators that regulate the voltage which is then attached parallel to a load. Hence, the voltage is controlled indirectly by the parallel attachment, the current is controlled from the regulation circuit element that is attached parallel to the load. Shunt regulators tend to use the functionality of a Zener Diode, which makes shunt regulators unique because of the Zener diode breakdown functionality that

regular diodes do not obtain. This allows the circuit to have a large current change with very little effect on voltage. A visual of the shunt regulator can be viewed below, Figure 4 [2].

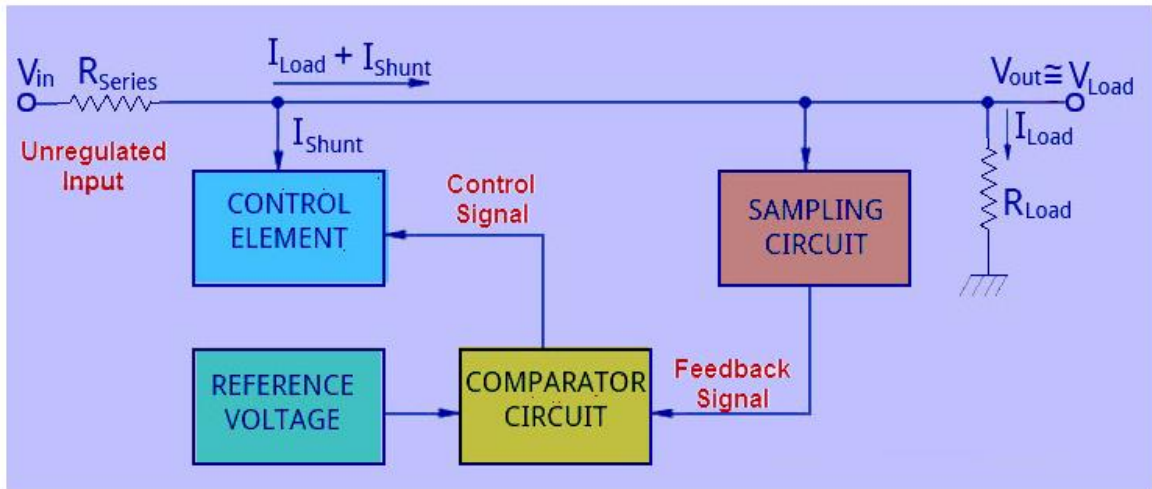


Figure 4: Shunt Voltage Regulator Topology

## Switching Regulator

Switching Regulators are the other type of voltage regulators. They are more efficient than the linear voltage regulators and offer higher voltage conversion for power systems. Linear voltage regulators tend to be around 50% efficient, whereas switching regulators can have up to 90% efficiency to barely no power loss. Most DC/DC converters are switching regulators. Implementing these into the GRAD system can increase power efficiency and ensure more accurate voltage values. This will allow better implementation and closer accuracy in terms of the voltage and current ranged. There are many types of switching regulators that can be analyzed. However, the components can be analyzed individually, while the technologies can be compared overall. Three common types of switching DC/DC regulators are Buck, Boost and Buck-Boost regulators. The Bust voltage regulator can also be defined as a step-down voltage regulator, the boost regulator can be defined as a step-up voltage regulator, and the buck-boost regulator can also be defined as inverting regulator. These regulators are displayed discussed in terms of their characteristics and components throughout the sections below.

### Buck (Step-Down) Voltage Regulator

The Buck voltage regulator converts a higher voltage into a lower one by using two semiconductors, usually a transistor that acts as a switch and a diode. The capacitors and inductors are implemented to decrease voltage change amounts, such as voltage ripples. These regulators tend to step voltages like 12V, 24V, and 48V and up to a lower voltage around 7V, 5V, or 1.8V. Buck voltage regulators also are very power efficient, usually about 90%, and are commonly used in computers and other applications for USB power input. The generic buck voltage regulator circuit can be seen in the Figure 5.

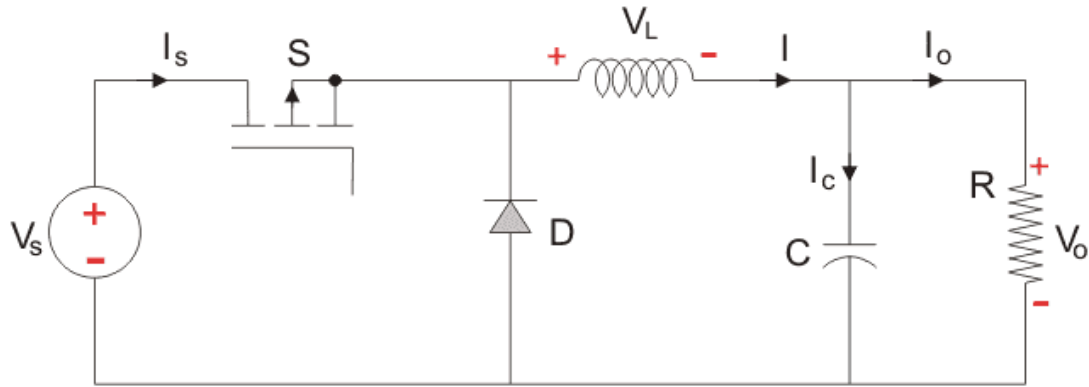


Figure 5: Buck Regulator Circuitry

(<https://www.electrical4u.com/buck-converter-step-down-chopper/>)

### Boost (Step-Up) Voltage Regulator

A Boost Voltage Regulator is similar to the Buck regulator however the Boost increases the output voltage from the input voltage. This regulator also tends to implement the use of a transistor and a diode into the system, as well as the capacitor and inductor. The generic circuitry of the regulator can be seen in Figure 6.

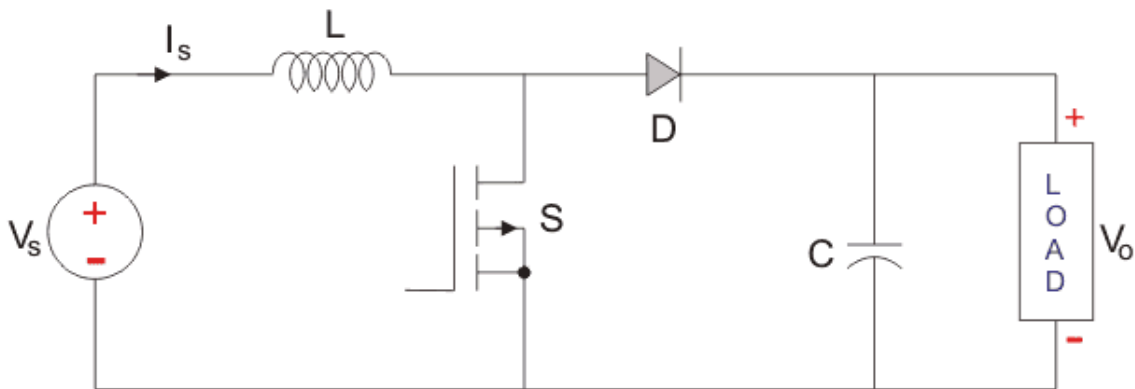


Figure 6: Boost Regulator Circuitry

(<https://www.electrical4u.com/boost-converter-step-up-chopper/>)

Boost voltage regulators tend to have very low losses due to the quickness of the switching of the devices. This would make the power in the system to remain the same. The output current of the system is lower than the input current, the voltage is increased due to the previous statement that the power must remain the same.

### Buck-Boost Voltage Regulator

The last common voltage regulator to be compared is the Buck-Boost Voltage Regulator, also called an Inverting Regulator. This voltage regulator output voltage can be either increased or decreased from the input voltage. However, the key component to this regulator is that the voltage output polarity is opposite that of the input polarity (Inverting

topology). This regulator is also composed of semiconductor devices (such as a transistor and a diode), as well as a capacitor and inductor [2].

### 3.2.3 Three vs. Four Wheel Drive Base

The three-wheel drive takes its basic roots from a four-wheel standard drive with two motorized wheels in the back used for the same purpose of applying force and making turns. Instead of another set of two wheels in the front, there will be one wheel for steering similar to a tricycle design. The three-wheel drive is also known as differential wheel drive and it is a most common design for basic robotics drive. The velocity difference between the two motors drive the robot in any required path and direction. As shown in the Figure 7 below, the differential drive can move forward, backward, make right and left turns by controlling the angular velocities.

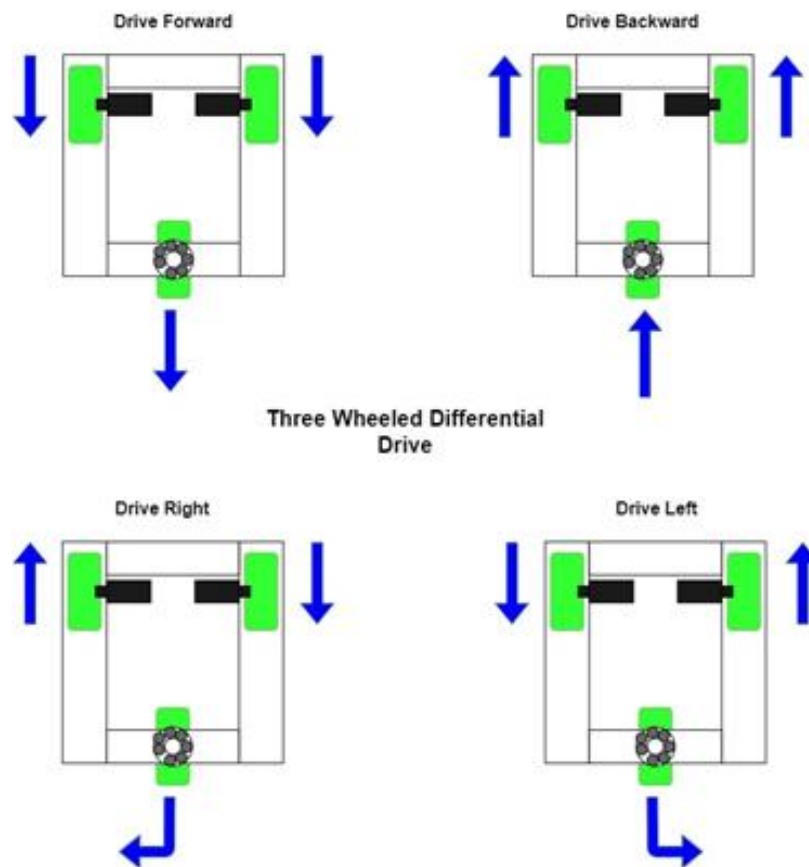


Figure 7: Three-Wheeled Drive controlled through angular velocities

The implementation of this design makes the mechanical construction as well as the control algorithm very simple [4]. However, one of the drawbacks of this design is that the drive is not always accurate due to DC motors. DC motors usually come in manufactured with a little difference in the number of rotations. This could be corrected after testing and evaluating the difference and accounting the correction factor in the program to either increase the speed of one wheel over the other or vice versa.

On the other hand, the four-wheel drive with two front swivel caster wheels provides a better weight distribution compared to a three-wheel drive on which the max force is exerted on the one wheel in the front. In terms of mobility, the standard drive with two swivel caster wheels would perform the same as the concept of a three-wheel drive. Another point to bring about the mechanics of a four-wheeled compared to three-wheeled is about the contact of the ground. The four wheels could easily lose stability if precision is compromised as one of the four wheels doesn't touch the ground exerting more stress on the other wheel. However, the three-wheel design seems to eliminate this with its third wheel in the middle always in contact with the ground providing extra stability.

As discussed above, the three wheeled design known as the differential drive which derives its inspiration of movement control from standard drive proves to be a better option. Not only are the key points discussed in the research above beneficial, the three wheels further reduce the cost of the drive base. Instead of two tires we needed to purchase, now we only need to purchase one swivel caster wheel.

### **3.2.4 Types of DC Motors**

We understood the basic configuration of a DC motor and how it works. There are different types of DC motors that utilize different techniques to provide certain benefits. The discussion below will focus on Brush DC motor, Brushless DC motor, Geared DC motor, and a Stepper motor. We will focus on the uses and advantages we could utilize for our project.

#### **Brushed DC Motor**

A brushed DC motor includes similar configurations to the rest of DC motors; however, it does not require a controller to switch current in the motor windings. The windings of a brushed DC motor are done mechanically where the commutator resides on the axle [5]. As the motor turns, dynamic magnetic field is generated inside the motor when a voltage is applied across the brushes. The brushes wear out as they slide each other and as a result, it is not used much in the industry as much in toys and RC servos. They are readily available and are inexpensive as they not as efficient as some other motor types and have low speed torque.

#### **Brushless Motor**

As the name states, it is indeed brushless. This motor type creates magnetic field in the rotor using permanent magnets attached to it. Compare to the brushed DC motor, it does not have any brushes to replace or wear out which makes it a top selection. As shown in the Figure 8 below, the configuration of the build is very similar to an AC motor having a synchronous property. Couple advantages over brushed DC motor include better efficiency, reliability, good speed control, and low noise [5]. Due to brushless motor's good speed control, it is used quite a lot in drone industry.

In terms of torque, brushless motors are not the best however, they can be modified to add gears in order to get a better torque. Many vendors sell attachable gear box which usually just fit in with the shaft of the brushless motor. For the purpose of our project, it would be good to have an efficient motor however, its probably not the best for torque.



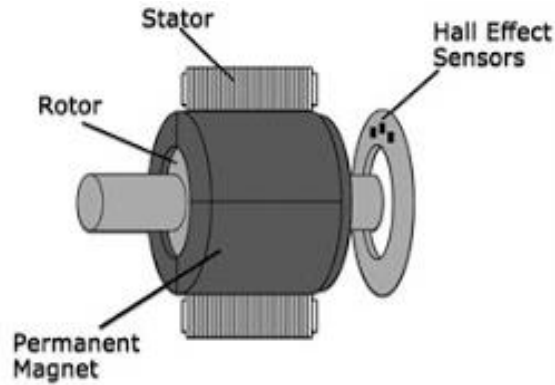


Figure 8: Configuration of Brushless Motor [6]

### Gear Motor

To simply describe a gear motor, it is a DC motor with gear assembled into the motor for better torque as show in Figure 9. With greater torque, it reduces the speed which is counted as rotations per minute (RPM). The high the input voltage, the more RPM it outputs. The working of the gears within the motor transfer more speed to the larger teeth rotating it which in return turns the smaller gear and so on until the shaft allowing it to conserve angular momentum. Gear motors are mostly used in robot drive trains, radio-controlled vehicles, etc. The only advantage it has over other motors is the ability to output increased torque.

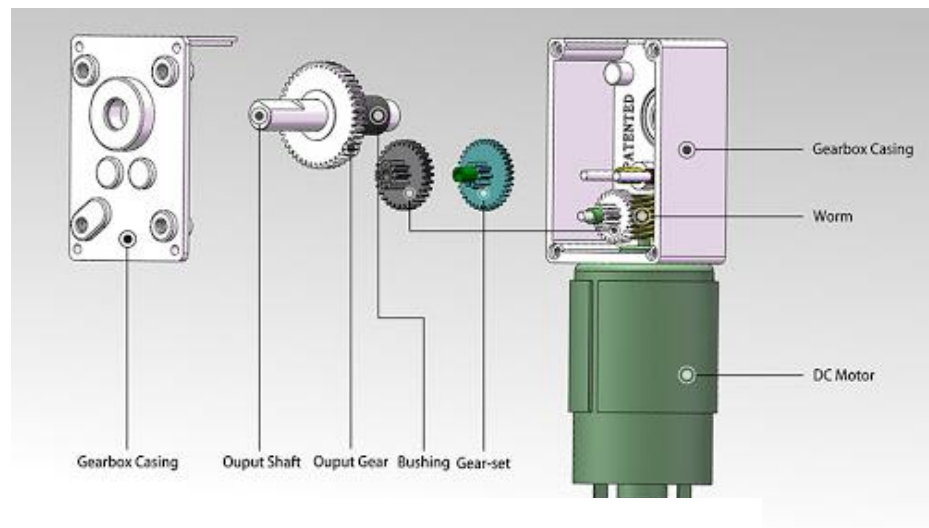


Figure 9: Diagram of a Gear Motor [7]

### Stepper Motor

As the name indicates, stepper motor moves in a discrete increment and does not rotate in continuous fashion like other DC motors. Similar to a brushless motor, it does not have a commutator and carbon brushes but uses many magnetic teeth like stator with individual windings. Due to its precise step movements, the stepper motor is widely used in technologies such as 3D printers, CNC machines, and robotics. Besides the advantage of

precision control, it has good holding torque to maintain its position and a slight disadvantage of low speed.

## 3.3 Component & Part Comparison

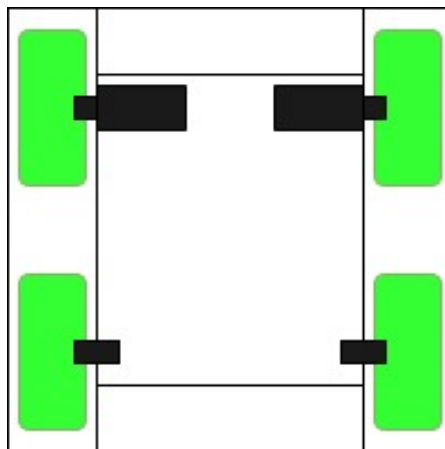
### 3.3.1 Drive Systems

A crucial part of a design for any type of a ground maneuvering robot is determining the type of drive system. Depending on the need of the robot, the goal of the drive system is to move the robot from one point to another while also being able to overcome obstacles on the way. There are different kinds of drive systems and each drive base has its own benefits. The drive base designs can allow the robot system more functionality, for example being able to move sideways while also turning and moving forwards and backwards. Some of the drive base designs considered for our needs included a standard drive, Mecanum drive, and track drive.

Our needs for the GRAD system included being able to go over different types of terrains such as concrete, grass, and go over small bumps such as mulch, little rocks, etc. Besides being able to drive over different terrains, it should be able to do basic maneuvers such as turning left and right, driving forward and backward. Overall, the drive base should be reliable and simple but also considerate of our budget of \$600.00 for the whole project. Below, we will discuss three of the drive bases under consideration in more detail while comparing to our needs.

#### Standard Drive

The Standard drive system is a common base drive that is usually powered by two motors from the back and two wheels in the front for steering as shown in Figure 10 below.



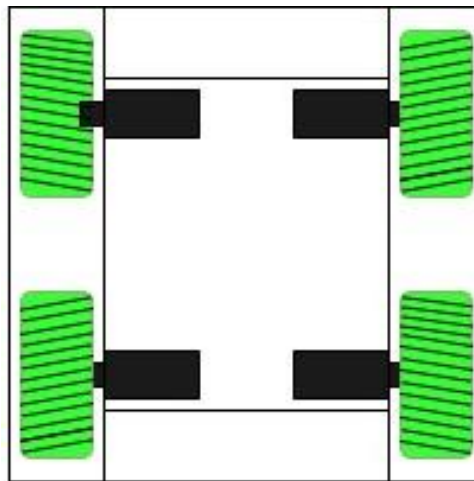
*Figure 10: Standard Drive Base*

The two motors in the back directly power the steer wheels in the front and depending on the load, the front wheel can also be motorized and act as a four-wheel drive similar to a car. Without any extra components, this drive system allows simple turns such as left and right and move backward and forward. It can be simply programmed to drive by controlling

each motor to drive back and forward, and power one motor to make simple right and left turns. This drive base allows the flexibility of adding motors for extra push force in case of high payload while also being able to easily integrate this design into an existing frame structure. With this drive system, our GRAD system can benefit from its simple design and maneuverability, flexibility that allows addition of four-wheel drive if needed, and does not require extra parts such as links or special tires. A 6-inch plastic wheel costs about \$8.00 per wheel and a motor between the range of \$25.00 to \$35.00 per motor, would total to a minimum of about \$82.00. Overall, it is cost efficient for our budget and simple design reduces complexity which makes it a favorable choice.

### **Mecanum Drive**

This drive system utilizes special types of wheels called Mecanum which allow the drive system to move sideways in addition to regular right turn, left turn, front drive, and back drive. The Mecanum wheels have rollers attached at an angle throughout the tire's surface which allows them to be omni-directional as depicted in Figure 11 below.



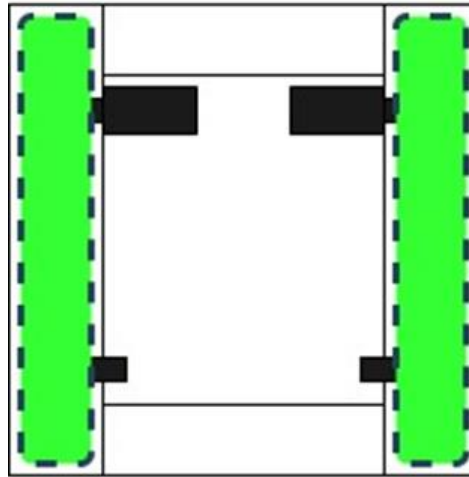
*Figure 11: Mecanum Drive Base*

The addition of sideway drive allows superior maneuverability and could be used in our GRAD system to make precise movements but it will also add complexity in the design, and additional cost. This drive system also requires a high torque motor for every Mecanum wheel to independently control each wheel which adds a lot to the cost on top special Mecanum wheels. A low quality 4" Mecanum wheel costs about \$30.00 per wheel and with four wheels, it will already cut our budget by \$120.00 without motors. The implementation of this drive system requires complex programming compared to a standard drive or tank drive as each wheel is controlled with addition to a fifth motion of sideway drive. Although this drive system offers maximum maneuverability with precise movements, it will create a burden on our budget which puts this option as the least favorable.

### **Track Drive**

Tank drive is known famously for going over obstacles such as military tanks. Instead of wheels like the standard drive or the Mecanum drive, track drive uses tank treads which

is like a belt connecting back and front wheel together on each side as shown in Figure 12 below.



*Figure 12: Track Drive Base*

But instead of wheels, it uses a set of four track sprockets which are connected to motors and these allow the tank tread to move. This formation of the drive allows the drive system to easily go over obstacles which is great for our GRAD system as it requires to go over different terrains. It can either be powered by two motors or four for extra torque. It can make turns, drive backward and forward, but it lacks traction which is dependent on the quality of tank treads used. In terms of programming the track drive system, it is very similar in simplicity to a standard drive in which each of the motors are independently programmed to make turns and work together for forward and backward motion.

This drive system meets most of our requirements however, the integration of track drive into a design is complex and costly. A good set of four sprockets cost about \$9.00 and a good quality tank tread chain costs about \$48.00 per foot, but we need at least four feet of tank tread so a rough total cost of this drive base cuts our budget by \$201.00 without motors. Compared to other drive systems discussed, track drive will cut our budget the most by 42% which puts this option at the bottom of the list.

After researching thoroughly and comparing each of the three different drive base systems, we have concluded that the Standard Drive system would be the best option for our project. Although the other two drive systems offer great alternatives and superior results in some areas, standard drive still remains as the top option because it meets all of the requirements for our needs set forth in the beginning of this research. As shown in Table 5, the standard drive option requires a minimum of two motors, it is able to maneuver basic turns, it can overcome obstacles, and go over different terrains. The two requirements that give this drive system an edge over the other two is its flexibility to adopt into a design and offering the lowest estimated cost which is just under \$90.00 compared to others where their cost is above \$200.00. The standard drive system also allows the design to choose between three wheel design or two wheel design. Overall, the standard drive system is the most cost efficient considering our limited senior design budget and it simply meets all of our requirements.

	<b>Standard Drive</b>	<b>Mecanum Drive</b>	<b>Track Drive</b>
<b>Min. Motors Required</b>	2	4	2
<b>Maneuverability</b>	Good	Excellent	Good
<b>Ability to Overcome Obstacles &amp; Terrains</b>	Very Good	Good	Excellent
<b>Drive Base Adaptability to overall Design</b>	Yes	No	No
<b>Programming Complexity</b>	Intermediate	Advanced	Intermediate
<b>Estimated Cost</b>	~ \$82.00	~ \$220.00	~\$251.00

*Table 5: Comparison of Drive Systems*

### **3.3.2 Selection of Garbage Bin**

We have considered many options including different types of trash bins currently in use. Currently, most of the communities that have waste management come to pick up daily trash or recycle material from their households use a 48-gallon size bin with two-wheels. For our design and prototype, we are considering using a similar trash can but smaller in size to reduce overall cost to meet our budget. The goal of using a similar trash can is to do a proof of concept and implementation that could be later scaled to various sizes of trash cans.

The chosen trash needs to be modifiable at the bottom to add a standard drive as chosen in our research. The addition of all of the components increases the weight of the GRAD system so we have to be very selective in choosing our trash can by looking into certain key aspects such as comparing weight, quality, base wheels, attached lids, and overall cost.

Below, we will discuss a few 32-gallon trash cans available in the market considered for our GRAD system body. The chosen trash cans for comparison are picked for their standardized design. Having a standardized design allows our trash can to be compatible with most automated waste management systems. The square shape allows easy picking up by lifting machines compared to a round shape that is prone to slide out of the claw more. We also want an attached lid so we can attach solar panels to the top side of our GRAD system. With an attached lid, a user can open the lid or if time allows, we thought about making the lid automated so it opens if the user approaches the trash can. Not having

an attached lid would create a problem in our design as it would make it more difficult to implement our requirement of solar panels. In the standardized design of outdoor trash cans, there are usually two or four wheels to easily drag the trash can to the curb and we have both types of trash cans in our research.

### **Blue Hawk Two Wheeled Trash Can**

This is a plastic two wheeled trash can that weighs about 7.6 pounds. It has an attached lid that secures the trash very well. The overall shape of the design is square, and all sides are flushed with small ridges. It has two wheels in the back as seen in Figure 13 (the picture is obtained from Lowes listing), however, the size is not mentioned in the product specifications. This is a budget-friendly product of Blue Hawk which is an entry-level brand of Lowes [8]. This is listed at Lowes for \$19.98 which is a great price for our budget, however considering it is not a known brand product, the quality of the material is questioned. The shell width seems thinner and it is utilized mostly for extra side trash can and not necessarily for industrial or residential homes. As the price is quite low for such a big sized trash can, it is expected that the quality of the plastic is not the best. Overall, this is trash is probably on top of our list considering the cost.



*Figure 13: Blue Hawk Two-Wheeled Trash Can [9]*

### **Toter Two Wheeled Trash Can**

This trash can is also a two wheeled and weighs about 20 pounds. The body of this trash can is built with an overall square shape but the design has deeper ridges that allow more flexibility as seen in Figure 14 (picture obtained from The Home Depot product listing) for it to be compatible with different types of waste management pickup systems. Toter trash cans are often found in residential community homes. Toter is a known famous brand for making different kinds of trash cans and sturdy products. This 32-gallon Toter trash can is also built using commercial-grade and recycled materials. It also has 8-inch rugged wheels that do not slide easily so it adds a good grip. Overall, it is one of the top-quality trash cans that withstand heavy usage and is built to last in tough weather conditions which makes it cost higher than the previous trash can discussed. We expect the sturdiness of the trash can to hold the solar component of our project well on the lid.



*Figure 14: Toter Two Wheeled Trash Can [10]*

The Toter two wheeled trash can is listed at \$59.98 at The Home Depot [10]. For our project, we could utilize the big wheels in the back with an addition of one or two caster wheels in the front to build our drive base. Although it costs more than the previous trash can, the decision will also be considered on the quality of the product.

#### **Rubbermaid Four Wheeled Trash Can**

This trash can is unique compared to the previous two discussed. Instead of just two wheels in the back, it also has two caster wheels in the front to distribute weight evenly for better mobility as seen in Figure 15 (picture obtained from Amazon listing by Rubbermaid) and doesn't need tilting.



*Figure 15: Rubbermaid Four Wheeled Trash Can [11]*

The body design of this trash can is also very similar to the Toter as it is standardized with deep ridges that make it compatible with waste management system lift equipment. The manufacturer, Rubbermaid, is also known for making quality trash cans that withstand rough conditions and this puts this trash can at the same level of quality as Toter. Due to higher quality material, the weight of this trash can is 20.7 pounds. It has an attached lid similar to the previous two trash cans, however it is very flushed making it a good surface

to attach solar panels. The wheels could be repurposed for our drive base however, they are not rigid as Toter wheels and could degrade their thread overtime when used on different terrains. The cost of this trash can amount to \$197.11 which is even higher than the previous Toter design as shown in Table 6. This trash can will cut our overall budget by almost 33% which we cannot afford as our electronic parts are expensive as well. Thus, this would be the least favorable of all of the three products.

	<b>Blue Hawk</b>	<b>Toter</b>	<b>Rubbermaid</b>
<b>Wheels</b>	2	2	4
<b>Weight (lbs.)</b>	7.6	19.9	20.7
<b>Quality</b>	OK	Great	Great
<b>Cost (\$)</b>	\$19.98	\$59.98	\$197.11

*Table 6: Comparison of selected Trash Cans*

As seen in table 6 above Comparison of selected Trash Cans, two trash can stand out as we narrow our options. The 32-gallon size trash cans from Blue Hawk and Toter are on top of our list however, the decision will come down to quality or cost. Both the Blue Hawk and Toter trash cans have 2 wheels, however, they differ very much in weight, quality, and cost. The weight reflects the quality and the quality reflects the cost for each of two narrowed choices. This is a harder choice to make as the Blue Hawk perfectly fits our budget and design goals but lacks in quality while the Toter trash can costs a lot but ensures the quality of the product. Due to our low budget, we might not select Toter trash can over Blue Hawk trash can unless we can find a used Toter trash can at a lower price. Nevertheless, we as a team still need to make a final decision once we have a chance of inspecting Blue Hawk quality to make sure it can withstand our modifications to meet our goals.

### **3.3.3 Selection of Swivel Caster Wheels**

In selecting the third swivel caster wheel, we need to note few factors in terms of size, weight load capacity, and design fitting. For the size of the caster wheel, we need to find one based on the sizes of the back two tires. We know from our selection of the Blue Hawk and Toter trash can that the size of the wheel is 8 inches and we want to lift the front side of the GRAD body off of the ground by the same height. Caster wheels come with metal casing that includes the swivel hub and a plate at the top to attach it to an object with screw.



Beside the size of the wheel itself, the casing also adds about 1 inch of height depending on the size of the wheel. Thus, we would need a caster wheel with a size of 3 – 4 inches with an addition of 1 inch of metal casing to match up with the wheels in the back or it could be a little below. It would be acceptable to have the front side of the GRAD body pointing down on an angle a little helping with the forward momentum.




Besides the size of the caster wheel, we need to also make sure the wheel can handle the maximum load. For the project prototype, our goal is to have the GRAD system weight no more than 40 pounds which includes the trash can body and all of the electronics; and be able to accept 20 pounds of trash at the least based on an average household trash bag weighing 22 pounds according to Zender Environmental Services [12]. Making our minimum weight to a 60 pounds. To meet our requirement, we want the wheel to be able to take a load of 60 pounds at the minimum and although not required, to a max of 90 pounds in total. Another element of we need to consider in choosing the best caster wheel for our project is the design fitting. Caster wheels come in variety of sizes and shape for multiple uses. Design of a caster wheel with a top plate for an attachment will suffice our need to attach it to the bottom of our GRAD body flushed to the surface. However, due to different sizes and shapes, we are expecting to make modifications in order make it work. With these basic standards set, we should be able to choose the most effective swivel caster wheel for our project drive base. Below we will discuss some chosen swivel caster wheels to make a final decision.

After researching tires in the market, we came across caster swivel wheels by Everbilt manufacturer that could be used for our project. We further filtered our results by load capacity of 175 pounds and wheel size of 3 inches. As seen in the Comparison of Wheel Selection table, all three Everbilt wheels are similar but still have minor differences. Wheel A has a total height of 3.75 inches including the wheel itself and the metal casting which is close to a 4 inch of needed height. It has plate mount easy installation to a flush surface. We could mount the plate to the bottom of the GRAD structure with four screws.

On the other hand, we have wheel B which has a total height of 3.64 inches and has two more features compared to wheel A and C. It has a stem mount which could be used to screw to the bottom surface and will require additional holding so the entire casting doesn't move itself. It also has a brake that could be used to lock the wheel from moving however, it is not necessary for our project to reduce human interaction when operating. The cost of wheel B is \$10.75 which is \$1.75 higher than wheel A. Although we could use the design of stem mount, it lacks the height we need so it will not be a top choice.

Finally, we have wheel C which has a total height of 3.94 inches. The height is very close to our needed requirement. It also has a plate mount like wheel A and has a thermoplastic rubber like wheel B. This swivel caster wheel could be easily attached to the bottom of the trash can or even added to an extension. The overall design that allows easy install as well as the thermoplastic rubber makes it a good choice considering whether conditions.

The above selected swivel caster wheels are summarized in Table 7 below with key differences to make final decision.

<b>Selection of Everbilt Caster Swivel Wheels</b>			
	(A)	(B)	(C)
<b>Total Height (in.)</b>	3.75	3.64	3.94
<b>Caster Mount Type</b>	Plate	Stem	Plate
<b>Wheel Material</b>	Soft Rubber	Thermoplastic Rubber	Thermoplastic Rubber
<b>Price (\$)</b>	\$9.25	\$10.75	\$10.41

*Table 7: Comparison of Wheel Selection*

To come to our final decision of selecting the best caster swivel wheel for our project, we will eliminate wheel B as it has the least height requirement. This leaves us with choices of wheel A and C. Wheel A and C both use plate mount however made with different materials and have a slight height difference. To prioritize our requirement of height, we would have to choose wheel C over wheel A. Although wheel A costs less than wheel C, wheel C uses thermoplastic rubber which provides sturdy, yet quiet operation and the cost is still less than wheel B.

### 3.3.4 Motors

There many essential parts to our GRAD system, however motors is one of the critical components that will allow our GRAD system the ability to move. In order for our GRAD system to go to the curb, the motors attached to the wheel will push the wheel forward from point A being near the house to point B which is the curb. As discussed in drive base designs, we will need two motors in the back to independently control each wheel. Figure 16 shows us the four basic movements required including moving forward, backward, left and right. The motors will work together to move wheel forward and backward, but they will move in opposite directions to each other in order to make left and right turns making it critical for the motors to be independently controlled.

The motors that will be used will have to handle the load while being able to precisely work together to go straight and also work with our electronic system. In researching for the ideal motors for our case, we will discuss the mechanics and basic physic calculations

needed to make motor selection requirements. Then we will research different types of motors and make the best selection. Since we are using a direct current source to power our GRAD system, we will look into DC motors.

### Motor Mechanics & Physical Calculations

A basic understanding of a motor consists of magnets, commutator, and rotor coil. In a DC motor, when a current is applied from a DC source such as a battery, the rotor coils become electromagnet. The commutator is an important component of the motor as it allows the spinning motion of the coil. Commutator acts as rotary electrical switch made out of copper with two key gaps. As shown in the Figure 16 below, once an electrical current pass through a brush which is usually made out of graphite, it gets in contact with the split-ring commutator which is connected to a looped coil.

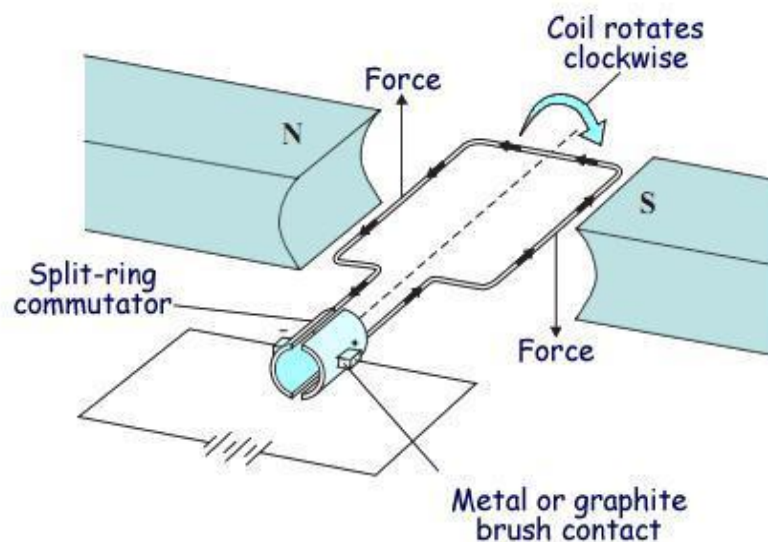


Figure 16: Conceptual diagram of a DC Motor [13]

As the current moves from one split of a ring to another, it moves the current in opposite direction in the coil. With external magnets encasing the coil, it reverses the polarity of electro-magnet created by the coil amateur. The opposite sides attract and like sides retract, creating a motion best explained using Flemings left hand rule. The continuous reversal essentially turns the battery's DC power supply into alternating current, allowing the armature to experience torque in the right direction at the right time to keep it spinning. The spinning of the coil continues as long as there is current. This spin force is utilized in many applications to either move something from one place to another or keep it stationary for an application.

From understanding the mechanics of a motor, we learn that power, voltage, and current are in relationship. The speed is proportional to the voltage applied and the power produced by the motor in return is proportional to the voltage times the current. This proportional relationship could be best stated with the following formula:

$$\text{Power} = \text{Voltage} \times \text{Current}$$

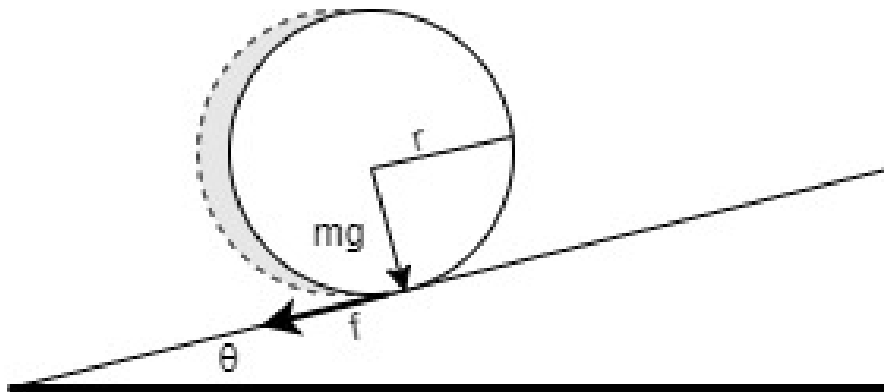
$$P_{\text{watts}} = V * I$$

Now we know that a voltage is a key indicator in selecting the motor. The other physical aspects of the environment must also be considered. One aspect of the physical environment of the motor used is the amount of load. Depending on how much load is placed, the motor draws electrical current with varying amps. One can estimate that the more load a motor takes, the more torque or the force to pull the object as it exerts its weight down will be needed to move the load. The greater the torque required, the more current the motor draws which show us that torque is related to current. In order to find out the torque required for our GRAD system, we have to first understand what exactly is torque and calculate the amount needed to pull the weight.

We understand that torque is related to the weight, but we are actually calculating the force the weights pushes downward. Torque is measured by multiplying the total force exerted by the distance as show in the formula below:

$$\text{Torque} = \text{Force} \times \text{Distance}$$

Torque is calculated in units of distance per weight such as foot per pound, ounces per inches, or of course using metric units. In order to calculate all of the forces, we will use the diagram on Figure 17 to guide us in calculations while illustrating all of mechanics.



*Figure 17: Illustration of different forces acting*

In order to understand the nature of forces better, we need to consider the gradient resistance. Gradient resistance is when our GRAD system moves up in the driveway incline with a certain degree, the weight will push in the opposite direction of its actual motion. In a case where there is not enough energy to propel the GRAD system up the incline, the whole body of the trash can will stall or torque of the motor is not able to hold its place, it will roll backward.

To avoid this, we will calculate the forces by considering the degree of angle, the weight exerting force along the road surface and perpendicular to the road as shown in Figure 18.

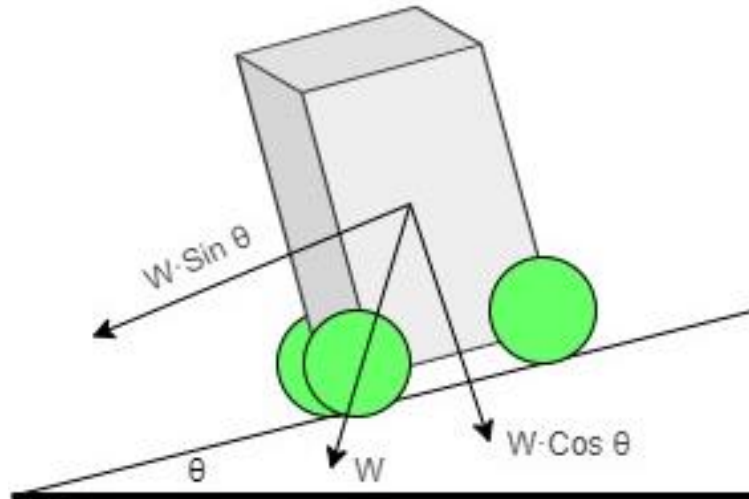


Figure 18: Illustration of forces to calculate Gradient Resistance

From the Figure x, one can calculate the gradient resistance by taking the force along the road surface ( $W \cdot \sin \theta$ ) and the weight of the whole GRAD structure. The two components of gradient resistance are best represented by the formula below:

$$F_G = W \cdot \sin(\theta)$$

We will use our requirement of at least 60 pounds of weight and max 75 pounds for the GRAD system should be able to handle in our calculation. In most driveways, there is usually some degree of incline requiring us to take this factor in our consideration. The incline of a road is generally measured in percent (%) grade instead of degrees to quickly assess the effort needed to go against the slope. The percent grade in mathematical terms is the tangent of the angle measured from the horizontal.

Typically, a road that rises 1-in-10, is otherwise called a 10% grade. For our calculations however, we will need to convert that to degrees. A 10% grade is about 5.7 degrees. The lowest incline is usually about 5% grade which is 2.9 degrees. To stay in a good range, will try to aim at 5 degrees incline in the calculations.

We will use the values discussed above in our calculation as follows:

$$F_G = w \cdot \sin \theta = mg \sin \theta$$

$$35.834 * 9.8 * \sin 5 = 30.6067N$$

Now we know that the gradient resistance force is about 30.6 newtons. Next, we need to consider the rolling resistance. It's known that there is a friction when you drive your vehicle on the road acting against the motion of the tires and in the same way, the wheels on the driveway will also encounter the same resistance force as the wheel roll down creating friction which is known as rolling resistance. The rolling resistance can be measured by multiplying the coefficient of the rolling resistance by the mass and the gravitational acceleration. This can be best expressed in the formula below:

$$F_R = RR \text{ coefficient} \times mg$$

We will use 0.01 as the rolling resistance coefficient and the max mass of GRAD system in kilo grams of 35.834 and 9.8 meters per second for the gravitational acceleration. The result of this calculation is as follows:

$$\begin{aligned} F_R &= 0.01 * 35.834kg * 9.8m/s \\ &= 3.511N \end{aligned}$$

In order to break the inertia and reach dynamic coefficient of friction, there is a third type of force which is usually four times the coefficient of the rolling resistance. Now will add all of the forces together to find the total resistance force.

$$\begin{aligned} \text{Total Resistance Force} &= 30.606 + 3.511 + 14.14 \\ &= 48.2N \end{aligned}$$

At this point, we now know the force need to move the GRAD trash can is 48.2 Newtons. This will allow us to calculate torque which will be used to select the motors. Now we will actually plug in the necessary numbers in the formula discussed earlier to calculate torque in metric units.

$$\begin{aligned} \text{Torque} &= 48.2N * 0.1015 \\ &= 4.886 Nm \end{aligned}$$

Now that we know torque we can go ahead and look at motors however, to get a good estimate of a commercially available motor that we can use for our project specification, we should also consider other variables. Another specification usually used to select motors is the revolution per minute (RPM). In order to calculate the revolutions per minute, we will need to find out the total time taken to cover the distance, rotations required, and we should know the time to cover the trip as well as the RPM.

We also need to consider the velocity which is the speed at which the GRAD system will move. We know the diameter of tires to be 8 inches, so about two rotations of the full tire will reach us over a foot of distance. We do not want the smart trash can to move too fast for safety concerns so we will consider a speed that is low enough for someone to walk with the trash can as an example.

We also know that an average driveway is about 24 feet so a round trip will be 48 feet. We will round the distance to 50 feet for easier calculation and considering any extra distance. Knowing that it takes about less than 2 full rotations to cover 1 foot, we can assume that going at about 7 to 8 inches per second is slow enough for safety reasons as well as good amount of speed to cover this short distance.

We will now take the above values and calculate the time to cover the total distance by using the formula below:

$$\text{Time taken} = \text{total distance} / \text{velocity}$$

Dividing the total distance of 50 feet by 0.656 feet per second, we get 76.2 seconds of time taken to cover the total distance. Now in order to find the rotation required, we have to first find the circumference of the wheel by making use of known formula of circumference.

$$C_w = 2 \times \pi \times \text{radius}$$

Half of 8 inches of diameter is 4 inches which is about 0.33 feet and we multiply that by  $2\pi$ , and we get 2.073 feet. Now we take the total distance again and divide by the circumference of the tire to find rounds per trip needed. This comes out to be 24.11 RPT which is about 18.95 revolutions per minute.

Now we have two very important variables that can help us find the motor we need. However, the calculation we did is the overall values of torque and not divided over the two motors we will use. So, for each motor, the torque we need to look for is about 2.8 Newton meters or 396 ounces of force per inch. This value of torque of a single motor and RPM should allow us to find a reasonable motor.

### **Motor Power Calculation**

We have researched into the physical nature of our drive system and made calculations that will help us determine how our motors should function. With those values calculated, we can also calculate the estimated power consumed by the drive system. The formula to calculate power includes the two critical values of torque and revolutions per minute for the motors. We will also use a mechanical efficiency of 60% in our calculation. The formula below expresses all three of the components discussed above to calculate power.

$$\begin{aligned} P_w &= (2\pi \times \text{RPM} \times T)/60 \\ &= (2\pi \times 18.95 \times 4.886)/60 \\ &= 9.7w \end{aligned}$$

The above power calculation results into 9.7 watts of drive system power used. We can assume that if the motors are run at their optimal value, the above wattage will suffice. However, we will add into account motor efficiency of about 75% to get a better estimate.

$$9.7w / 0.75$$

This gives us a power value of about 12 watts rounded down. We can now rest assure that our calculation accounts for all factors weather it is mechanical design or motor efficiency. With the above given wattage of the whole system, we can divide it between two motors to know how much each motor will use. A rough estimate gives us a value between 5-6 watts.





In order to conclude on which, type of DC motor we will be choosing; we will focus on what is required by our project. With varying weight, we want the motor to be able to handle torque and still be able to function well. This allows us to take out brushed motor type and brushless as they do not have a gear assembly in the motor to meet our torque requirement.

Although a gear box could be added separately, we are constrained by the space and adding a separate gear assembly will make it complex and costly. This leaves us with the option of stepper motor and gear motor. Stepper motor is great for precise position adjustments and holding torque however, it has a disadvantage of a low speed. With gear motor on the other hand, we can have the torque we require and adjust the speed with varying voltages

applied. Gear motor will be a better option as it used often in drive trains and meets our requirements.

### Selection of Motor

After doing research and calculation of what kind of motors we need for our project, we have concluded that DC gear motors would be best in our case as there is a heavy load that will require high torque. As determined in the *Motor Mechanics & Physical Calculations* section of this report, we will need DC gear motors with 2.8 Newton meters (Nm) or 396 ounces of force per inch (ozf-in) and 18.95 revolutions per minute (RPM). The motors available in the market do not have to meet the exact specification but it is preferred to find anything that is either exact or above the calculated values. Having a higher value ensures that it will still perform better in case the calculation values underperform. The preferred method of purchasing motors was online due to the current situation where local businesses are closed. We selected a few motors that were in our range from different vendors as show in the Table 8.

<b>12V DC Gear Motors</b>	 <b>Bringsmart Worm</b>	 <b>AndyMark NeveRest</b>	 <b>Sparkfun Standard Gearmotor</b>	 <b>ServoCity-Econ Spur Gear Motor</b>
<b>RPM:</b>	16	105	20	19
<b>Torque: (Nm)</b>	70 kg/cm 6.86 Nm	593 oz/in 4.18 Nm	185 oz-in 1.30 Nm	192 kgf-cm 18.82 Nm
<b>Price: (\$)</b>	\$28.24	\$28.00	\$24.95	\$14.99

*Table 8: Selection of Motors*

As seen in the Table 8 above, it is very difficult to find an exact match to our calculated values of motors needed however, there is a variety of motors with different ranges. The Bringsmart Worm Gear motor has 6.86 Nm torque and runs at 16 RPM. It is a good motor with torque but its RPM is below our requirement and cost is higher than other motors so this would be the last choice. Next, we have NeveRest gear motor from AndyMark manufacturer which has a torque of 4.18 Nm with a really high RPM rate of 105. The RPM is too much for our purpose however, it is a better choice than the Bringsmart Worm gear motor in terms of value and return output.



The next two motors are manufactured by Actobotics and are sold by different vendors. The standard Gearmotor runs at 20 RPM and only has a torque of 1.30 Nm which way below our required torque requirement so this will be put to the bottom of our list of choices. However, ServoCity Econ Spur Gear motor runs at 19 RPM which almost meets our exact specification but has a really high torque which is not bad quality. This makes the Actobotics Spur Gear motor and Andymark's NeveRest gear motor our top two choices as they both do not fall under our specifications and over meet some aspects of our requirements. To decide between these two motors, we have considered the third variable of price since torque and RPM requirements are met. The Actobotics Spur gear motor costs about \$15.00 and we can get two for about \$30.00. On the other hand, we have Andymark's NevRest gear motor which has a quite high price of \$28.00 and with a second pair, it will cost us about \$56.00. Although both motors are great, but considering our limited budget, we rather choose the Actobotics Spur gear motor as it is almost half the price of the other one. The high torque might make the motor slower but for the purpose of our project, we do not really need a high-speed motor either and it should do at least the minimum of what is required.

### **3.3.5 Printed Circuit Board**

A Printed Circuit Board (PCB) is used to control power flow in the system and connect the microcontroller or an embedded computer to all the components of our system, such as the sensors and motor. A PCB is the substitution for a breadboard-oriented circuit. Unlike a breadboard circuit, a PCB is a permanent solution where a material called solder is used to connect components such as resistors and capacitors permanently to the circuit. A PCB is also useful as circuit components can be in smaller size and soldered directly to the PCB eliminating unwanted space. A PCB can increase the accuracy of a circuit compared to a breadboard or wired circuit and decrease the amount of wires that would be required by otherwise. Having excess wires can increase the amount of connection issues with the system and may affect the functionality of the system. Making these wires into traces on the PCB decreases any human errors during wiring. The PCB also allows the system to be secure against user interference and can even increase the safety of the project as it decreases the possibility of loose wires. Overall, the main purpose is to connect the components of a system to send signals and power across physical hardware in an efficient process [14].

A PCB is composed of many layers as seen in Figure 19. According to SparkFun most PCBs are comprised of some type of top layer called a silk screen, followed by the solder mask (the material described above), copper (the main element of the PCB), and lastly followed by some type of Substrate (usually Fiberglass or FR4). If the PCB is a double layer then both sides of the substrate will be covered in the copper layer and then the solder mask. PCBs can even have up to 16 layers or more. The substrate is the structure of the PCB, it is essentially the bones of the system. The copper layer is then applied which will allow for current flow through the system and allow for connection to the board. Then the mask is layered on top of the copper layer to insulate the copper traces and separates metal parts to eliminate accidental contact. Then the silkscreen is applied which will allow for text and various other writing needs [14].

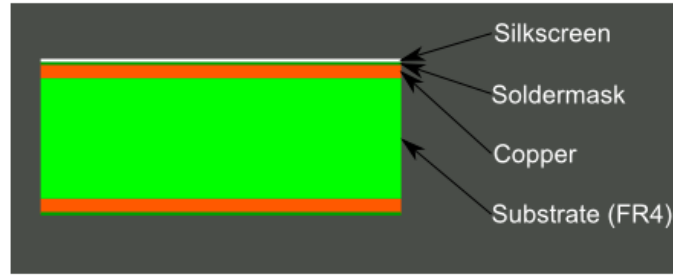


Figure 19: PCB Composition Diagram

### 3.3.6 Power Supply

The PCB will require some sort of power supply, which through the PCB will be regulated and altered for the GRAD system to function properly. To supply the system an external power supply, an internal power supply, and a combination of the two are considered in powering the GRAD system.

#### External Power Supply

The GRAD system can be powered using an external power supply from the household. The typical household outlet in America provides 120VAC at 60hz. Since 120VAC voltage is larger than 5 - 12V needed and microcontroller input is needed in DC voltage, the 120VAC voltage must be reduced using a transformer then put through an AC to DC converter. A transformer is a device that usually has an iron core with wire windings on opposite sides. Transformers use the idea of electromagnetic flux. A transformer has a winding to voltage or current ratio. The number of windings is directly proportional to the voltage level. Therefore, to obtain 12V from 120V would require a turns ratio:

$$\frac{12V}{120V} = \frac{1}{10} = \frac{N_{turn12V}}{N_{turn120V}}$$

Hence for every single turn on the 12V side there must be 10 turns on the 120V side. The next step is to change the AC voltage into a DC voltage. Diodes are a semiconductor device that act as a switch, if the voltage from the source is greater than that of its destination node it will act as a closed circuit. Once the voltage from the source is lower than the voltage at the destination it will act as an open circuit. Implementing diodes and the transformer into a bridge rectifier circuit. The bridge rectifier circuit is a full wave rectifier circuit which will transform the entire AC signal into DC voltage whereas if a half wave rectifier was used only half of the AC wave will change to the positive of the AC signal. Therefore, the full wave bridge rectifier would be chosen, which can be seen in Figure 20. The full wave bridge rectifier circuit is composed of 4 diodes. This will ensure the full AC wave is transformed into a positive AC wave. The next step is to add a capacitor to the circuit in parallel with the system output. Implementing the capacitor into the circuit will bridge the gap between AC peaks and create a DC voltage effect. The capacitor brings the voltage from a sinusoidal closer to that of a flat DC voltage [15].

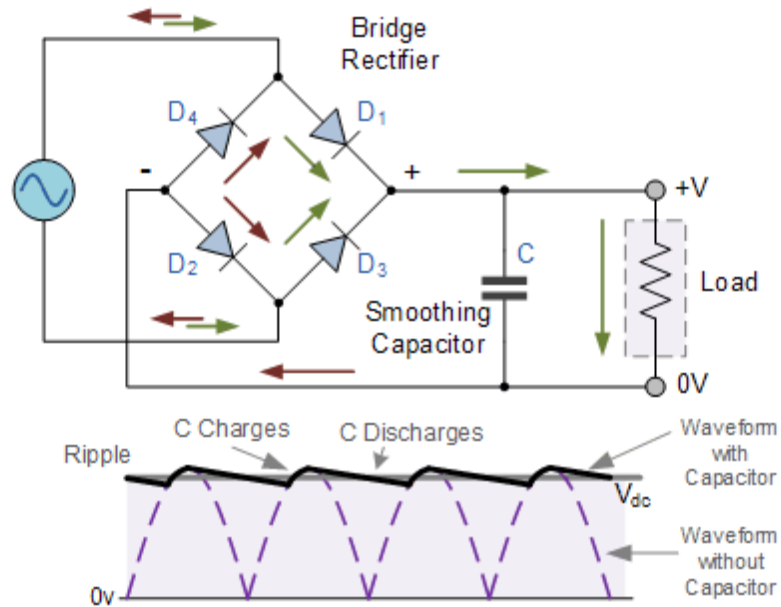


Figure 20: Full Wave Bridge Rectifier Circuit With Output (Electronics Tutorials)

For external conversion a power cable with an inverter can be easily acquired. This power cable will allow all the transformation from AC to DC and from 120V to the 5-12V range which would be necessary for the voltage regulation.

A solar panel is another option to consider for an external power source. A solar panel will eliminate the need to connect the GRAD system to an electrical outlet. This will increase the user ease and feasibility. The output of a solar panel is DC voltage, this would also not require an AC to DC conversion. Most solar panels also output a lower voltage between 3-12V. This would not require voltage regulation for the microcontroller, which requires a voltage input in the range 5-12V. However, with a solar panel alone as the power source, the energy from the source will be used as it is produced. The solar panel will not provide enough energy at the time of motor usage. This will require an internal battery storage system in combination with the solar panel (analyzed below).

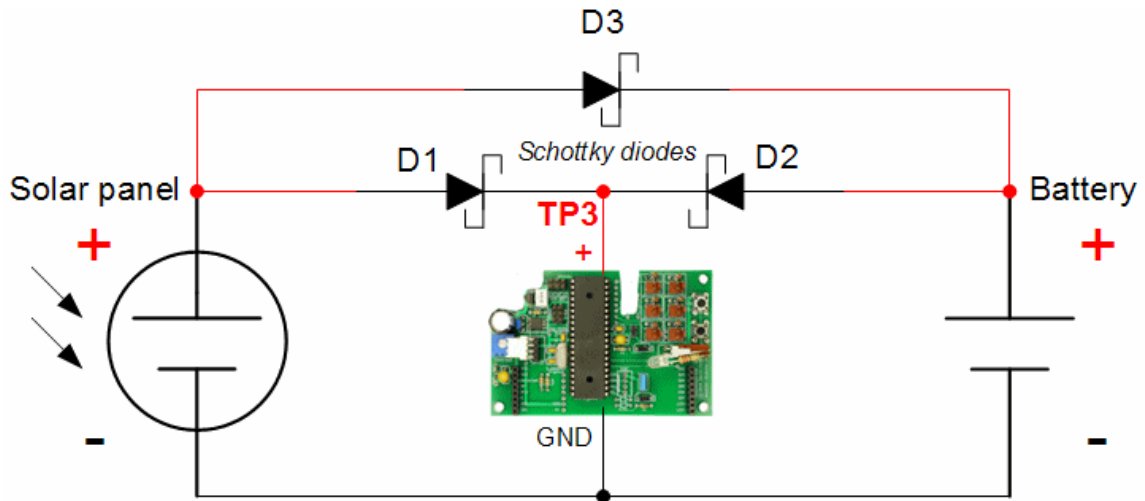
### Internal Power Supply

The GRAD system can be powered using an interval battery source. A battery is useful as the system's power source is transitable and is with the system at all time. No wire connection to outlet would be required. However, the problem is that a battery has only a limited source. Without recharging of the battery this would require constant battery changes when the total energy is used up. This methodology is not cost-effective and useful for the user of the system.

### External and Internal Power Supply

Both an external and Internal power source seem inconvenient as a standalone. Therefore, integrating them together is the best and most efficient option. Implementing solar energy as the power source and having an internal battery storage system will allow the robot to

operate when output of the solar panel is not enough to supply the system (such as evening time or early morning robot movement). The system could implement a charging cord from a typical household outlet. However, this would require the user to continuously plug the system in. A Schottky can be used to ensure battery and solar panel proper usage to the device implementing the circuit seen in Figure 21, will allow the solar panel to operate if needed when the battery is full. Diodes are useful for regulating the voltage level.



*Figure 21: Simple Solar Recharging Circuitry (No Voltage Regulation)*

A certain voltage threshold must be obtained between diode nodes to ensure proper functionality. Hence the battery is full the diode will turn into an open circuit to ensure the solar panel stops charging the battery. However, if the GRAD system wants to be operated at a time no sun is available hence, the solar panel is not operating, the GRAD system can rely fully on the energy stored within the battery. The reason a Schottky diode is being implemented in the circuitry is because of its functionality that separates it from a normal diode. A Schottky diode has a lower forward voltage drop than a regular diode, which means the voltage across it can be less than a regular diode leading to faster switching. A regular diode tends to have a forward voltage drop of about .6V to .7V, whereas a Schottky diode tends to be in the range of .15V to .46V. This leads to fast switching rates making the system more reliable while also increasing its efficiency [16].

Lastly, due monetary constraints the GRAD system will run from a combination of the Solar Panel and Battery Storage. This is the simple way of charging the battery while implementing the GRAD system. This simple circuit will be altered in the voltage regulation section for a more reliable and complex regulation of the circuit. Since Figure 10 is a simple circuit to allow the charging and recharging of the battery, it does not consider any voltage regulation. Overall, using only the battery and solar panel will result in the GRAD system operation time being reduced. It is expected to run out of battery storage within a few hours, therefore this product is used for research to further trash collection ease. Implementing the option to plug the system in allows for 24-hour activity or acquiring better and more expensive techniques could be used to improve this project (future goal). The plug-in option decreases the user ease and functionality of the system.

Hence, the proposed GRAD system will also have capability to run only during daylight to eliminate the user need to plug in.

### **3.3.7 Batteries**

There are multitudes of batteries within the market, many robotic systems are encouraged to use Lithium Ion or Polymer Batteries or Nickel-Metal Hydride Batteries. These batteries tend to have better charging and discharging capabilities, as well as they tend to be lightweight. Compared to lead batteries which are heavier, decreased shelf life, these lithium and nickel-metal batteries tend to be more expensive and have less choices to choose from [17]. However, Lead Acid batteries will also be considered in the analysis of the battery choosing due to the common popularity of the battery, the multitude of resources available to the team for design implementation, low price for user battery replacement, and commonality for purchasing. Different types of batteries that could be implemented into the GRAD system will be analyzed.

#### **Lithium Battery Power 12V 6AH LITHIUM BATTERY**

A Lithium Ion battery is a rechargeable battery that is commonly used for vehicles, boats, robotics and various other uses. Lithium Battery Power's 12V 6Ah lithium battery weighs 1.75lbs, and its dimensions are 5.75" L, 2.5" W, 3.75" H. It has a nominal voltage of 13.8V with a capacity of 84Wh. It contains a 10-year warranty. This battery is small and lightweight.

#### **Lithium Battery Power 12V 12AH LITHIUM BATTERY**

A Lithium Ion battery similar to the one discussed above however it contained double the capacity. This battery's energy capacity is 12V 12Ah and it weighs 3.2 lbs, and its dimensions are 5.9" L, 3.85" W, 3.75" H. It has a nominal voltage of 13.8V. It contains a 10-year warranty. This battery has double the storage of the previous one yet is small and lightweight still. It contains enough energy storage for the GRAD system.

#### **Polymer Li-ion Battery: 12V (133.2 Wh 4A rate) with Regulator (10.8)**

This polymer Lithium battery (similar to a regular Lithium Battery however polymer is used in the interior rather than an electrolyte) from Batteryspace.com is composed of 4 batteries, a regulator, and 5A PCB. This battery pack has a nominal voltage of 12V and contains a capacity of 9000 mAh or 133.2 Wh. It weighs about 1.9lbs and its dimensions are 6.37"L x 2.51" W x 2.67"H.

#### **AT: Tenergy 12V 10000mAh NiMH Rechargeable Battery Pack**

Tenergy Power's rechargeable Nickel hydride rechargeable battery pack is composed of Sub C batteries. This battery pack has a nominal voltage of 12V with a 10000 mAh capacity. Its total weight is 3.35 lbs and has a Wh capacity of 120. This battery pack has a charging rate of 1A. Tenergy recommends that Nickel Hydride batteries be changed once every six months to ensure proper voltage and proper operation. This battery pack has a unique shape of 12.8"L x 2.28"W x 1.18"H.

### Weize 12V 20AH Lead Acid Battery

The Weize 12V 20Ah battery system transitions into a capacity of 240Wh. This battery contains the most Wh capacity of all the batteries discussed. Since this battery is comprised of Lead Acid, this could reduce the efficiency of the battery and not result in a total of 240Wh. However, due to the high difference between this battery capacity and the other analyzed, this battery should still provide the most capacity. The Weize 12V battery weighs about 12.28lb which makes this battery the heaviest battery. The dimensions of this battery are 7.1” L x 6.6” W x 3” H. This battery also is the largest but will fit nice on the bottom of the trash can. Initially this battery should be eliminated from the overall product comparison but it considered for ease of the user.

Battery Comparison	Cost	Weight (lbs.)	Size Rank (1=smallest)	Capacity (Wh)	Additional Info
Tenergy 12V 10000mAh NiMH	\$96.99	3.35	1	120	Made of D Cells, build time required
Lithium Battery Power 12V 6AH LITHIUM	\$59	1.75	2	84	Lithium Tends to be explosive
Lithium Battery Power 12V 12AH LITHIUM	\$124	3.2	3	144*	Lithium Tends to be explosive
BatterySpace Polymer Li-ion Battery: 12V	\$204.95	1.9	4	133.2	Built in Regulator, Fire Retardant Bag
Weize 12V 20AH Lead Acid Battery	\$36.99	12.3	5	240	Heaviest, Cheapest and Most Capacity

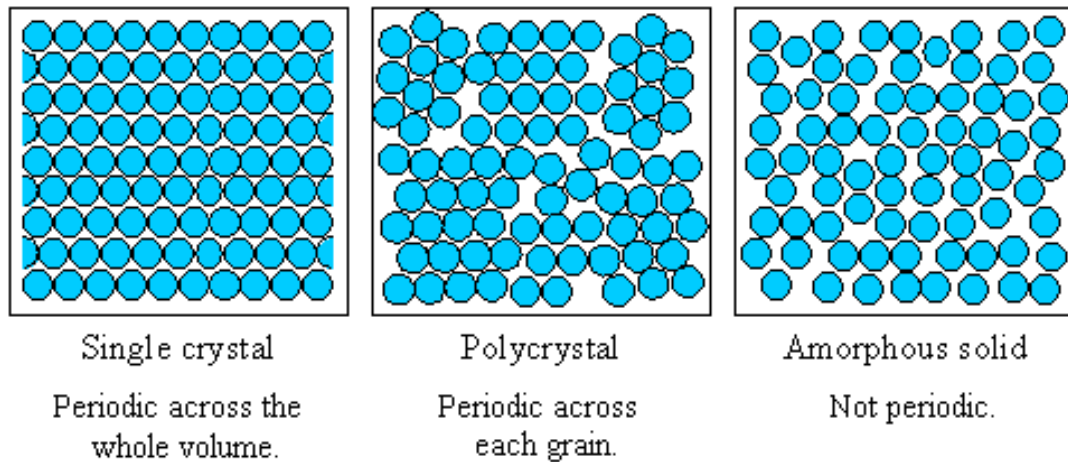
*Table 9: Battery Analysis*

The Table 9 above presents the categories that are most important when choosing between the presented batteries. One of the most important factors is cost in combination with capacity. Then comes weight and size, if the battery can be used for the GRAD system. The Nickel Metal Hydride battery would be chosen because it tends to be a safer choice than lithium, it has a large capacity. The battery itself is quite heavy compared to the rest, however the size of the battery is smaller than the others in area. However, due to monetary constraints and the power constraints the Group decided to implement a Lead Acid battery for more energy capacity at a lower cost. Therefore, the **Weize 12V 20AH Lead Acid Battery** is chosen for this project. This product results in 240 Wh which is higher than all

the above batteries and has a final cost of \$36.99. Like previously discussed, implementation of this battery will assist in any customer in terms of maintenance, device awareness and decreased cost for future battery replacement. The only downside to this battery is the weight of 12.3 lbs, which will may significantly impact upon the performance of the system. Lead acid is also another downside which could affect the efficiency of the system, as the battery may loose capacity overtime or due to heat.

### 3.3.8 Solar Panels

Polycrystalline, Monocrystalline and Thin-Film panels will be compared below. The organic solar cells will not be considered due to the fact that the above silicon cells tend to have a high efficiency, are more common and have been in the market for a longer period of time. This would increase the reliability of the solar panels. Monocrystalline has the highest efficiency of the three types of panels, followed by polycrystalline and Thin-Film. This is due to the fact that Monocrystalline are from pure crystalline whereas the silicon inside polycrystalline is separate fragments of silicon that is molded together through a heating process. Thin-Film solar panels are the least efficient of the three because of its composition. Usually, Thin-Film solar cells are composed of many different elements and compounds or it can be made from amorphous silicon. Amorphous silicon is a non-crystal version of silicon [18]. The figure below, Figure 22 displays the difference in the molecular structure of each solar cell type:



*Figure 22: Solar Panel Material Diagram*

(<https://www.doitpoms.ac.uk/tlplib/atomic-scale-structure/intro.php>)

In terms of cost, monocrystalline has a higher cost than polycrystalline. Thin film price varies in comparison due it being flexible, lightweight and portable. Thin-Film is also popular due to the cleanliness of its production, as their production does not result in toxic metals. In Figure 23, it shows the visual differences between the panels [1].

In terms of cost, monocrystalline has a higher cost than polycrystalline. Thin film price varies in comparison due it being flexible, lightweight and portable. Thin-Film is also popular due to the cleanliness of its production, as their production does not result in toxic

metals. Thin film is most often used in mobile applications, such as in a backpack or various other methods that require lightweight and portable functionality. These materials have different compositions which correlate into different visual appearances. In Figure 23, it shows the visual differences between the panels [1].

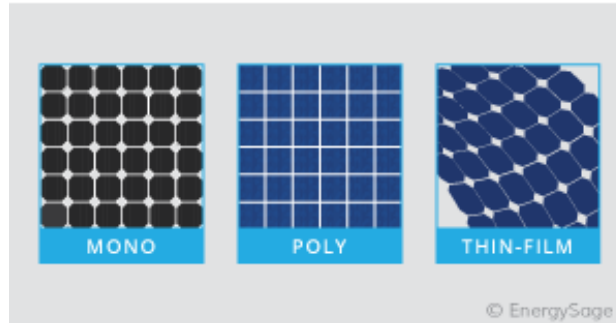


Figure 23: Solar Panel Types (EnergySage.com)

### **Solarland SLP010-12U Silver Poly 12 Volt Solar Panel**

Solarland's Polycrystalline silicon solar cells 12V solar panel operates at 12V with 10W of power. It contains 36 solar cell panels/connections. It weighs 4.63lbs with dimensions of 11.89"L x 14.06"W x 1.18"H. It outputs a current of 0.58A.

### **Renogy 10-Watt 12 Volt Monocrystalline Solar Panel**

Renogy's 10-Watt 12V Monocrystalline Solar panel operates with 12V and 10 W of power. Monocrystalline tends to have a higher efficiency than other solar cell compounds. This specific panel has a solar cell efficiency at 21%. It contains 32 solar cells, summing to a weight of 2.65 lbs and dimensions of 10.6" L x 13.4"W x 1.0"H. Renogy estimates this panel produces a daily output, depending on weather conditions, of 40Wh. It contains a 25-year power output warranty with a 5-year material and workmanship warranty. This panel is accompanied with a frame with pre-drilled holes for easy implementation into the GRAD system.

### **Renogy 30-Watt 12 Volt Monocrystalline Solar Panel**

Renogy's 30W 12V monocrystalline solar panel has a cell efficiency of 21%. It contains 32 solar cells per sectioned panel totaling 22.4" L x 13.4"W x 1"H. This panel has a total weight of 6.2lbs. Renogy estimates this panel produces a daily output, depending on weather conditions, of 120Wh. This panel also comes with the same warranty, frame and pre-drilled holes that Renogy's 10W panel offers.

### **Solar Power Calculations**

The National Resource Energy Laboratory (NREL) is a national lab dedicated to research, development and implementation of renewable resource materials. NREL has a database comprised of solar radiation per zip code (kWh/m<sup>2</sup>/day). The zip code for the University of Central Florida is 32817, which has an average solar irradiance of 5.09 kWh/m<sup>2</sup>/day. This is based on a yearly average, depending on the month and day this will fluctuate from 3.2 to 6.7. This number aims to include weather as it is based upon average and data



collection from the NREL [19]. However, numbers could fluctuate due to certain weather conditions. According to NREL the Normal Operating Cell Temperature (NOCT) derate factor is .731 [98]. The next step is to take solar panel data. For these calculations the Renogy 30-Watt 12 Volt Monocrystalline Panel will be chosen for analysis, as it is the best candidate for the GRAD system. With, the specifications sheet for this device states that the PDC, STC is 30W which is calculated with the assumption of STC Irradiance of  $1\text{kW/m}^2$  and operation temperature at  $25^\circ\text{C}$ . To calculate the amount of energy that the system will be supplied the equation below will be implemented:

$$\text{Energy}(Wh/d) = PDC,STC * \text{Derate Factor} * (h/d \text{ Peak Sun})$$

For calculation purposes the h/d Peak Sun is calculated assuming there is 1-sun insolation ( $1\text{kW/m}^2$ ), just as stated in the solar specifications sheet. Therefore, dividing  $5.09 \text{ kWh/m}^2/\text{day}$  will get 5.09 h/d of peak sun. Implementing these numbers into the equation results in:

$$\text{Energy}(Wh/d) = 30W * .731 * 5.09 = 111.6 Wh/day$$

This number will vary due to the weather and sunlight conditions, as well as the seasonal conditions. The tilt and position can also affect this number. Therefore, the estimated energy charge per day from the solar panel will be estimated to be  $100\text{Wh/day}$ .

However, the tilt of the solar panel as well as the azimuth angle will also affect the solar panel directly. This will alter the above calculation. Since the solar panel in the GRAD system design will be placed on top of the system and lay flat the tilt will be zero, as the panel will face directly up. This will reduce the efficiency of the panel and have a decrease in the daily energy production. Since, the GRAD system will travel to the end of the driveway on an estimated once per week alongside of implementing low power modes within the system, this should allow the battery storage to fully recharge before any desired movement. The azimuth is the angular position of the solar panel according to the coordinate North, East, South and West. For optimum results in the northern hemisphere it is calculated that the best azimuth be  $180^\circ$ , which is facing directly South.

### 3.3.9 Voltage Regulator

As previously discussed, there are many types of voltage regulators of both types linear voltage regulators and switching voltage regulators. Since the GRAD system has many components and different elements which require different voltage levels an analysis of different voltage regulators is required to ensure proper functionality of the system. The voltage from the solar panel to the battery must be regulated as well as the voltage from the battery to the microcontroller. Since the battery is a nickel-metal hydride battery, it is not as explosive as the Lithium options however the battery accepts a range of voltages. Overvoltage and overcharging of a battery can ultimately lead to damage of the battery, including life reduction or physical damage, or even the user. Components and other sensors will also have to be regulated, if needed, from the microcontroller pin output voltage. Table 10 displays different voltage regulators that are considered for the GRAD system PCB. As previously discussed, linear voltage regulators tend to be more applicable for lower options and have a lower efficiency, whereas the switching regulators are more efficient and can handle higher voltage application better.

Voltage Regulators	TL2575H V-05	LM1084IT-5.0	LM7805MP/NOPB	LM2748	LM2576T-12/NOPB
Input Voltage Min (V)	4.75	2.6	7.5	1	4
Input Voltage Max (V)	60	25	35	14	40
Output Voltage Fixed (V)	5	5	5	12	12
Output Current (A)	1	5	1	20 (max)	3
Price	\$1.32	\$2.59	\$2.77	\$0.90	\$2.77
Type	Switching Regulator	Linear/ Low Voltage Dropout	Linear Voltage Regulator	Switching Buck Regulator	Switching Regulator
Store	TI	Mouser	Mouser	TI	Digit-Key

*Table 10: Voltage Regulator Analysis*

From the above table, voltage regulators that are both switching and linear voltage regulators are considered for both voltage output levels of 5 and 12V. Voltage from the solar panel to the battery will require 12V to 12V regulation to ensure the proper DC voltage is acquired, as well as accurate current. Since the battery is charged with 1A or 5A (fast), the LM2576 will be chosen to go from the solar panel to the battery. For any components and dependent upon which microcontroller or embedded computer that is chosen will affect which regulator is chosen. The TL2575 switching regulator is a step-down regulator that gives a vast range of input voltages and would ensure a 5V 1A output. This regulator will be used for the 5V input components that would require any voltage regulation.

### 3.3.10 PCB Design Software

The Printed Circuit Board (PCB) used small components and decreased the size of the circuit completely. This requires prototyping and planning. Many softwares can be used to create the circuitry schematic and then create the printed circuit board design layout. Eagle, CircuitMaker, Kicad, Orcad, DipTrace and Altium Designer are different PCB design softwares that are useful for the construction and design of the GRAD system. Most of these software programs have different prices, constraints, and processes in terms of the software itself. These software programs contain the tools for the creation of the system schematic, which then can be transferred into a PCB board layout and altered to prepare the design for construction. The PCB layout will then have to be exported for PCB manufacturing. Table 11 compares the PCB design software that are considered in the selection process.

PCB Design Software	Cost	Constraints	Layer	Miscellaneous
<b>Eagle Standard</b>	\$100/yr or \$15/month	160 cm <sup>2</sup> 99 schematic sheets	4 layers	Layout, schematic and Autorouter
<b>Eagle Free</b>	\$0	80 cm <sup>2</sup> 2 schematic sheets	2 layers	Layout, schematic and Autorouter
<b>CircuitMaker</b>	Free		16 Signal + 16 Regular Layers	Importer for other programs, Autorouter, Multi-layer editor
<b>DipTrace Standard</b>	\$125	1000 pins	4 Signal Layers	
<b>DipTrace Lite</b>	Free	500 pins	2 Signal Layers	

*Table 11: PCB Design Software Analysis*

The Eagle Free software will be used for the PCB schematic and PCB board layout. Previous experience with Eagle has been acquired through various classes through UCF and is free to use. Eagle also has many resources since Autodesk is used by many people and professionals. CircuitMaker will be used if desired, to which the started schematic or board layout from Eagle can then be imported to finalize any design requirements.

### 3.3.11 PCB Manufacturers

After completing the schematic design and converting the design into a PCB board layout. The file will be exported from the selected PCB design software and uploaded to a PCB manufacturer. From here the design will be fabricated and assembled into the physical board layout.

Analyzing Table 11, which can be seen below, it shows the JLCPCB would be the best option in terms of price, whereas ALL PCB would be the best in terms of time. Due to recent events of the coronavirus, which is affecting travel and national affairs, OSH Park is chosen. OSH Park is located within the United States and is the second cheapest option. While shipping time may take longer than some other options, it may be just as fast since it is domestically sourced. OSH Park also charges per the size of the PCB; therefore, our size could change dependent upon final design. Osh Park website seems easy to navigate and is user friendly, all one has to do is upload their PCB design files, the PCB is sized and proofed and then ready for design and creation. Shipping is no extra charge and included in the final board price. Therefore, Osh Park is chosen as the PCB manufacturer and assembler due to low price, ease of use, customer service, and domestic location. These pros should ensure the board is accurate and shipped within a reasonable time due to the global pandemic COVID-19.

PCB Manufacturers (200mmx200mm)	Cost	Shipping Cost	Total Cost	Build Time	Shipping Time
<b>JLPCB</b>	Engineering -\$4 5PCB-\$13.40	\$16	\$33.40	1-2 days	15-20 days
<b>ALLPCB</b>	\$2/per 1 <sup>st</sup> order \$20	\$24	\$44	48-72 hours	3-4 days
<b>OSH Park</b>	3 PCB - \$40	Free	\$40	9-12 days	N/A
<b>PCBWay</b>	5 PCB- \$66	\$16	\$82	24 Hours	10-15 days
<b>Seed</b>	5-PCB-\$65	\$16	\$81	3-4 Days	10-15 days

Table 12: PCB Manufacture Analysis

### 3.3.12 Embedded Computer

The following section outlines what an embedded computer is, how an embedded computer is different than a microcontroller, and how it would be used in our project. *Update:* After exploring different options for implementing path planning- including GPS, robot vision, and line following- we have decided to use line following since it is the most simple and accurate method out of the three. As a result, there is no need to use an embedded computer in our project.

If the GRAD system's path planning system will be implemented using robot vision, it will require an embedded computer to process real-time data. Information transmitted by sensors or input from a camera will be used for object avoidance and location services- the embedded computer will need to store data from these devices and use the data to make decisions on whether to proceed with the initial planned path. For instance, if the GRAD system begins its travel to the user's curb, but all of a sudden a squirrel runs across the driveway and blocks the GRAD's path, then the GRAD should perform a full stop until the squirrel is no longer in its path. The same concept applies whether the object to avoid is a squirrel, another animal, a child, an adult, a car, or any other object that may appear on the user's driveway. Although we will not be using the entire board for the final project, it is still necessary to compare embedded computers so that we can translate its components to a PCB, and have the PCB emulate the embedded computer. In addition, the embedded computer can be used in its entirety for initial testing phases, then we can integrate the GRAD system with a PCB at a later time.

The embedded computer that will be chosen for this project needs to have a sufficient amount of I/O ports to handle information to and from sensors, cameras, clocks, motors, and the power supply. It will also need to support Bluetooth or Wi-fi modules in order for GRAD to communicate with the user about scheduling trash days and to send notifications to the user (for example, if a delivery was successful or not successful, or if the weight of

the trash exceeds the maximum limit). If robot vision is chosen to implement the path planning system, the embedded computer needs to have a faster CPU and a larger memory to support AI and machine learning capabilities.

Thus, the embedded computer is essential for GRAD'S path planning system (including the implementation of safety measures), and in transmitting and receiving information to the user. Three different embedded computers are currently under consideration, and after comparing the strengths and weaknesses of each one, a decision will be made regarding which embedded computer would be the best fit for GRAD.

The comparison of embedded computers is illustrated graphically in Table 13. The various embedded computers being considered- the Raspberry Pi 4 Model B, NVIDIA Jetson Nano, and ODROID-XU4- are compared according to the quality of CPU, GPU, RAM, number of GPIO pins, power source requirements, presence of a Bluetooth/Wi-Fi module, and cost. The most cost-effective option is the Raspberry Pi 4 Model B at \$35.00, and the most expensive option is the NVIDIA Jetson Nano. The Jetson Nano's high cost, however, is due to its very powerful 128 core NVIDIA Maxwell GPU- so it would be worth the investment if we were to implement GRAD's path planning system using computer vision. The highest amount of RAM offered by the Raspberry Pi 4 Model B and NVIDIA Jetson Nano is 4 GB, and the ODROID offers half the amount of RAM at 2 GB. All three embedded computers operate on a 5 Volt power supply and draw between 2 and 4 amps of current. In addition, all the embedded computers offer at least 40 GPIO pins.

The only embedded computer that comes with a built Bluetooth/Wi-Fi is the Raspberry Pi 4 Model B, and thus it would be necessary to purchase an external Bluetooth/Wi-Fi component if we were to choose one of the other embedded computers. The embedded computer with the largest community of support is the Raspberry Pi and having a wealth of documentation and tutorials available online would be a huge advantage. In essence, the choice of an embedded computer all depends on if we will implement GRAD's path planning system using robot vision- in that case, we will choose the Raspberry Pi 4 Model B- or if we will be using robot vision, because in that case the NVIDIA Jetson Nano would be the best option since it has the most advanced GPU.

## **Comparison of Embedded Computers**

### **1) Raspberry Pi 4 Model B**

The Raspberry Pi embedded computers are one of the most popular brands on the market due to their affordability, compact size, and user-friendly design. Because it is widely used, learning how to use the Raspberry Pi would be made easy through the wealth of documentation and tutorials available on the web. The Raspberry Pi 4 Model B is the latest generation of Raspberry Pi embedded computers, and some of its specifications include: 40 pin GPIO header, 1GB, 2GB or 4GB of RAM, 1.5GHz 64-bit quad-core processor, Broadcom VideoCore VI GPU, Bluetooth 5.0, wireless LAN, 0 – 50 degrees C operating temperature, 5 volts DC operating voltage (minimum 3 amps), and a camera port. Notably, this embedded computer has machine learning capabilities, which would offer flexibility if we decide to implement GRAD's path planning system with computer vision. The starting price

for the Raspberry Pi is set by the 1 GB version, which sells for \$35.00[20], and an image of the Raspberry Pi is included below in Figure 24.

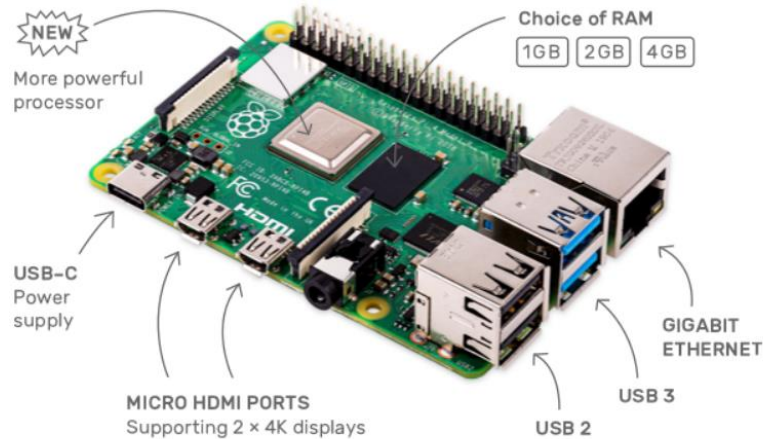


Figure 24: The Raspberry Pi 4  
Reprinted with permission from <https://www.raspberrypi.org/>

## 1) NVIDIA Jetson Nano



Figure 25: NVIDIA Jetson Nano, Licensed under CC 2.0

The NVIDIA Jetson Nano Developer Kit is a powerful embedded computer that supports applications for image classification and object detection. It is capable of running multiple neural networks in parallel, so it can simultaneously process input from multiple sensors. The Jetson Nano does not come with a Wi-fi or Bluetooth module, however, so an external Wi-fi or Bluetooth device will be needed in order to establish GRAD's communication system. Some specifications for the Jetson Nano include: 40 pin GPIO header, 4 GB of RAM, quad-core ARM A57 processor at 1.43 GHz frequency, and a 128-core NVIDIA Maxwell™ GPU[21]. An image of the NVIDIA Jetson Nano can be seen in Figure 25. Compared to the Raspberry Pi 4 Model B, the Jetson Nano has a much more powerful GPU- therefore, if the GRAD system's path planning will be implemented using computer vision, the Jetson Nano would provide faster and better support for the image processing required for GRAD to navigate to the user's curb. The Jetson Nano requires a 5-volt, 2-amp power supply to operate, and its starting cost is \$99.00. If the Jetson Nano is chosen for GRAD's embedded computer, it may be difficult to find supporting documentation and tutorials since it is relatively new embedded computer. Thus, compared to the Raspberry Pi, it is more expensive and has less support, but it also has a much more powerful GPU.

## 2) ODROID-XU4

The ODROID-XU4, which is manufactured by HardKernel, is a popular alternative to the Raspberry Pi. ODROID is a combination of the words “Open” and “Android”, and it supports modern operating systems such as Android and Ubuntu. Figure 26 shows a picture of the ODROID-XU4. The ODROID-XU4, similar to the Jetson Nano, does not come with a Wi-fi or Bluetooth module- therefore, an external Wi-fi or Bluetooth peripheral will be needed in order to establish GRAD’s communication system. Some specifications for the ODROID-XU4



Figure 26: ODROID-XU4. Pending approval

include: two GPIO headers, one containing 30 pins and the other containing 12 pins, 2 GB of RAM, quad-core ARM A15 processor at 2 GHz frequency, and an ARM Mali-T628 6 Core GPU[22]. It also comes with a cooling fan, which activates when the temperature of the board hits the minimum threshold temperature, or when the CPU is overloaded with tasks. The ODROID-XU4 requires a 5-volt, 4-amp power supply to operate, and its starting cost is \$49.00. As can be seen, the ODROID-XU4 boasts a higher clock frequency than the Raspberry Pi and Jetson Nano, and therefore its processing power is higher and it will be able to transfer data at a faster rate. Despite the higher performance of the processor, the ODROID line of embedded computers has less users than the Raspberry Pi line, and so it would be more difficult to troubleshoot problems and find supporting documentation for the ODROID.

	Raspberry Pi 4 Model B	NVIDIA Jetson Nano	ODROID- XU4
<b>CPU</b>	1.5GHz 64-bit quad-core processor	Quad-core ARM A57 processor at 1.43 GHz frequency	ARM A15 processor at 2 GHz
<b>GPU</b>	Broadcom VideoCore VI	128-core NVIDIA Maxwell™	ARM Mali-T628 6 Core
<b>RAM</b>	1GB, 2GB or 4GB	4GB	2GB
<b>GPIO Pins</b>	40 pin GPIO header	40 pin GPIO header	Two GPIO headers: 30 pins plus 12 pins
<b>Power Source</b>	5 volts, 3 amps	5 volts, 2 amps	5 volts, 4 amps
<b>Bluetooth/Wi-Fi Module included</b>	✓	✗	✗
<b>Starting Price</b>	\$35.00	\$99.00	\$49.00

Table 13: Comparison of Embedded Computers

**Note: Upon conducting further research, we have decided to not use any of these components**

### **3.3.13 Microcontroller Requirements**

If only sensors are used to implement GRAD's path planning system, it may not be necessary to use an embedded computer- a microcontroller may be sufficient for navigating the outdoor garbage bin to the user's curb, since it will not be processing large input streams from a video. The main difference between an embedded computer and a microcontroller is that an embedded computer is a complete computer that is built on a single board- unlike a microcontroller, it has an operating system, more storage for memory, and higher computing power. In essence, a microcontroller is the processor for an embedded computer.

The GRAD system would require the higher computing power of embedded computers if robot vision will be used for navigation- however, if no image processing will be implemented, then a microcontroller will be sufficient to complete the desired tasks for path planning. Similar to the requirements of an embedded computer, the microcontroller would need to process information transmitted by sensors and use that information to make decisions on whether to proceed with the initial planned path. The microcontroller also needs to have a sufficient number of I/O pins to accommodate motors, sensors, the power supply, real time clock module, and possibly an external Wi-Fi/Bluetooth module (if it does not already come with an internal Wi-Fi/Bluetooth support). The microcontroller will be responsible for gathering and processing information about GRAD's current location, desired destination, and any path obstacles in real-time, therefore, the selection of a proper microcontroller is essential for this project's success. Although we are not permitted to use the original microcontroller itself (in order to satisfy the implementation requirements of this project set by UCF), we can still use the board for initial testing phases, then we can emulate the microcontroller by designing our own custom PCB. Implementing a microcontroller with a PCB would be much simpler than implementing an embedded computer with a PCB.

Three different microcontrollers are currently under consideration, and after comparing the strengths and weaknesses of each one, a decision will be made regarding which one would be the best fit for GRAD. The microcontrollers that are under consideration are: 1) the Arduino Mega 2560, 2) the Texas Instruments MSP430FR9689 LaunchPad, and 3) the GeekNET ESP32 Development Board. The microcontroller does not necessarily need a Wi-Fi or Bluetooth module already built in, since it is possible to purchase an external module and connect it to the microcontroller. We are considering the Arduino microcontroller due to its friendly user interface and widespread popularity, and our team already has experience in programming the Texas Instruments microcontroller since it is used to teach UCF's Embedded Systems course. The ESP32 is also being considered due to the convenience of having a built in Wi-Fi/Bluetooth module. Many factors will influence our microcontroller selection, including CPU, compatible programming language, SRAM storage, number of GPIO pins, operating voltage, and total cost of the microcontroller.



# Comparison of Microcontrollers

## 1) Arduino Mega 2560

The Arduino platform is a very popular brand for boards due to its simple design and user-friendly IDE. Arduino has many software libraries available to install and use- they include built-in functions that make it easier to control sensors and outputs, and to perform other useful tasks. In addition, since a lot of people use Arduino, it is well documented, and a wide community of support exists. Having a solid support network could be helpful for debugging code or resolving problems similar to those that other people have previously experienced. Arduino uses its own programming language that is similar to C/C++, however, it is possible to use Arduino with other high-level programming languages such as Python. The Arduino Mega 2560, shown below in Figure 27, is an 8-bit board that operates at 5 Volts, and it has 54 digital I/O pins (15 of which have PWM output), 16 analog input pins, 4 UARTs, a 16 MHz clock speed, and 4 serial ports [23]. The Arduino Mega is available for purchase on the official Arduino website at \$38.50.

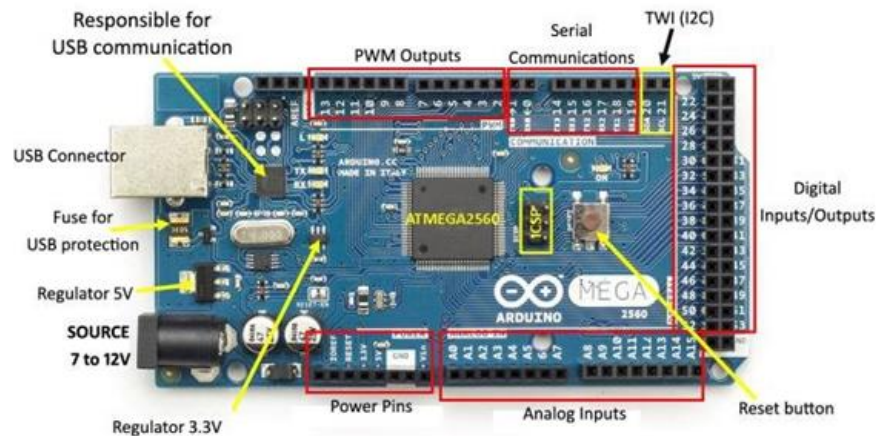


Figure 27: Arduino Mega 2560. Reprinted with permission from [www.arduino.cc](http://www.arduino.cc)

## 1) TI MSP430FR6989 LaunchPad

Another option for the microcontroller is the MSP430FR6989 LaunchPad MCU produced by Texas Instruments, as shown in Figure 28. This is the same microcontroller that is required for the Embedded Systems and Digital Systems courses at UCF, so each of our team members has laboratory experience in programming with this MCU. As a result of the prior experience in using this MCU, we are all adept in locating information in the official user's guide and chip data sheet. In addition, we would be able to refer to the lab manual for help, as well as other documentation available



Figure 28: TI MSP430FR6989

that is available online. Therefore, there would be a smaller learning curve if we were to choose this microcontroller. The MSP430FR6989 is a 16-bit microcontroller, and it supports a wide voltage range from 1.8 Volts up to 3.6 Volts. It also features 83 GPIO pins (including 2 I2C configurations, 4 SPI configurations, and 2 UART configurations), a 16 MHz system clock speed, 5 timers, multiple low power modes, 2 KB of SRAM, and 128 KB of FRAM [24]. This MCU is compatible with Texas Instrument’s software and hardware, so we could use the Eclipse based Code Composer Studio as an integrated development environment and, if needed, purchase additional booster packs to extend the hardware. The MSP430 uses TI’s C/C++ compiler, and its starting cost is \$27.99.

### 1) GeekNET ESP32 Development Board



Figure 29: GeekNET ESP32. Licensed under

processor, an ultra-low power co-processor, 2.4 GHz clock frequency, 36 GPIOs (including 4 SPI configurations, 2 I2C configurations, and 3 UART configurations), and 512 KB of SRAM [25]. The starting price for the ESP32 is \$10.99, making it the cheapest board out of each option being considered. The ESP 32 can be programmed in JavaScript, Python, C, or C++. There is also a variety of supporting documentation published online, including a free crash-course, videos, datasheet, modules, and forums to facilitate programming the ESP32.

The ESP32 board, which is produced by Geeknet, is yet another option for a microcontroller. The ESP32, shown in Figure 29, is engineered for IoT applications, mobile devices, and wearable electronics, so it should be suitable for implementing GRAD’S navigation system. The microcontroller features Wi-fi and Bluetooth functionality, and it can interface to other devices through its SPI, I2C, or UART interfaces. Its other specifications include an Xtensa dual-core 32-bit

The comparison of microcontrollers is illustrated graphically in Table 14. The various microcontrollers being considered- the Arduino Mega 2560, the TI MSP430, and the GeekNET ESP32- are compared according to the CPU, compatible programming languages, SRAM, number of GPIO pins, power source requirements, presence of a Bluetooth/Wi-Fi module, and cost. The most cost-effective option is the GeekNET ESP32 at \$10.99, and the most expensive option is the Arduino Mega 2560. The highest amount of SRAM is offered by the GeekNET ESP32 at 512 KB, while the MSP430 offers 2 KB and Arduino offers 8 KB of storage. Each microcontroller operates on a different voltage range- the Arduino Mega can withstand a maximum of 20 Volts, while the other two microcontrollers can withstand a maximum of 3.6 Volts. The only microcontroller that comes with a built Bluetooth/Wi-Fi is the GEEKNET ESP32, and thus it would be necessary to purchase an external Bluetooth/Wi-Fi component if we were to choose one of the other microcontrollers.

	Arduino Mega 2560	TI MSP430	GeekNET ESP32
<b>CPU</b>	8-bit ATmega2560 processor at 16 MHz	16-bit RISC Architecture at 16-MHz	Xtensa dual-core 32-bit processor at 2.4 GHz
<b>Programming Languages</b>	Cft, C++, Python	C, C++	C, C++, JavaScript, Python
<b>SRAM</b>	8 KB	2 KB	512 KB
<b>GPIO Pins</b>	54	83	36
<b>Power Source</b>	6 to 20V	1.8 V to 3.6 V	2.3 V to 3.6 V
<b>Bluetooth/Wi-Fi Module included</b>	✗	✗	✓
<b>Starting Price</b>	\$38.50	\$27.99	\$10.99

*Table 14: Comparison of Microcontrollers*

The microcontroller that we have chosen is the Arduino Mega 2560- due to its friendly user interface, existence of supporting documentation, and online popularity, we can find a wealth of information and tutorials on implementing line following into our project.

## Alternative Design Option

The iRobot Create 2 Programmable Robot is a pre-assembled mobile robot based on the Roomba brand of robotic vacuums. It is a STEM resource used by educators, developers, and students for programming with robots. The Create 2, shown in Figure 30, would simplify building the GRAD system by eliminating the need to assemble a drive system and deal with lower-level programming. In addition, the Create 2 comes with built in sensors that allow it to respond to its environment, which would take care of the GRAD object avoidance system. The Create 2 is also compatible with Roomba 600 Series accessories, including the Home Base, which is a designated hardware for the robot dock and recharge (the total time to recharge the battery is three hours). Because the Create 2 is capable of docking and recharging itself, which would make GRAD more user-friendly since the user would not need to worry about plugging in GRAD each time its battery gets depleted.



*Figure 30: The iRobot Create 2. Reprinted with permission from iRobot*

The Create 2 uses the Wavefront algorithm to implement path planning, and it is guided by proximity sensors and tactile sensors that implement dead-reckoning, which is the process of determining current location based on speed estimates from sensors [26]. The Create 2 has the following physical characteristics: it weighs approximately eight pounds, and it measures 13.39 inches in diameter and 3.62 inches in height [27]. Due to the small size of the Create 2, if we were to hack into this robot to repurpose it into the base of an autonomous garbage transport robot, we would need to decrease the size and weight of the garbage bin that would sit atop the Create 2 so that it can be safely supported. Therefore, we would only be able to produce a small prototype of our intended GRAD product.

In order to repurpose the Create 2 for our needs, we would need to attach an external computer/microcontroller to implement the communication system between the user and GRAD: the user needs to tell the GRAD system the exact dates and times it should transport the garbage bin to the driveway- which can be done through a Bluetooth or Wi-Fi module connected to the microcontroller/external computer- in order to program the robot's movements. If the Create 2 is chosen as a component for GRAD, it is likely we will use Python as our programming language and a Raspberry Pi as our embedded computer. The total price for the Create 2 is \$199.99, and it would come with a rechargeable battery, home base, and a connection cable. Thus, using the Create 2 as the base for the GRAD system would significantly decrease costs, since we would not need to purchase separate parts for the motors, sensors, and power supply. However, using the Create 2 as the base for GRAD would limit the size and weight of the garbage bin that could safely be fit on top of it. We also would not be able to use the path planning software that is already built in due to restrictions set by this course, so we do not have much advantage in using the Create 2.

## **3.4 Possible Architectures and Related Diagrams**

### **3.4.1 Communications**

GRAD requires a communication system to transmit and receive information between the user and the garbage bin. For instance, the user must specify the dates and times that they would like GRAD to travel across their driveway and to the curb. In addition, the garbage bin requires a method to notify the user of any anomalies that require attention- such as when the garbage bin is carrying more than the maximum weight, if the garbage bin tips over, or if the garbage bin was not successfully deployed to the curb. GRAD's communication system can be accomplished through the implementation of a Wi-Fi or Bluetooth module. The main purpose of the communication module is to allow the user to notify GRAD when to deploy the garbage bin to the curb. The user should be able to deploy GRAD through an application which communicates with the microcontroller. We will now explore how each of these modules would work and carefully analyze the pros and cons of each one to decide on which would be the best fit for GRAD.

If we decide to implement GRAD's communication system using Wi-Fi, our biggest fear is the unreliability of UCF Wi-Fi during presentation day- communication between the application and the microcontroller is very important, and without a proper connection between the two, we would not be able to deploy GRAD to take the trash to the curb. A solution to this would be to record an instance of GRAD successfully transporting trash to the curb on video, just in case UCF Wi-Fi fails us on our big day.

### **Wi-Fi Technology**

Wi-Fi, also known as “wireless fidelity”, is a wireless networking technology that is used for accessing the internet and for networking local area devices. The term “Wi-Fi” is synonymous with the IEEE 802.11 family of standards, which defines the most commonly used wireless computer networking standards around the world. IEEE 802.11 is used by many different devices including desktops, laptops, smartphones, tablets, drones, remote sensors, cameras, and more. IEEE 802.11 standards are discussed in further detail in the Applicable Standards & Design Constraints Section and are illustrated below in Figure 31 [30]. As its name implies, Wi-Fi does not require any wires to establish a connection between local area devices and the internet.

Wi-Fi uses radio waves to transmit and receive digital signals/data. Radio waves that are used for Wi-Fi can be categorized within several frequency bands: 900 MHz, 2.4 GHz, 3.6 GHz, 4.9 GHz, 5 GHz, 5.9 GHz and 60 GHz [28]. Each frequency range is divided into channels, each channel is identified with a number that refers to its center frequency. The main bands used for carrying Wi-Fi are 2.4 GHz and 5 GHz, with the 5 GHz Wi-Fi providing more bandwidth, less interference, and a shorter range than the 2.4 GHz Wi-Fi.

A wireless network can be created through a router and wireless access point, which can be an independent device or integrated within the router. The router acts as the traffic police

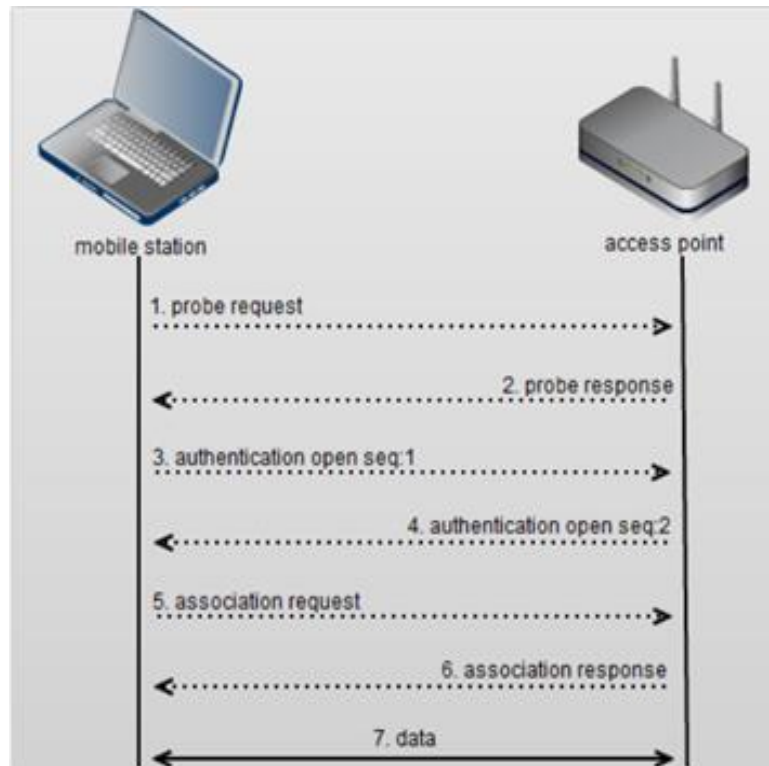
of the network, and it uses a wire to send signals/data to the Internet and an antenna to send signals/data to devices in the network. Some routers use a combination of different 802.11 standards, with 802.11n routers being the most common. The cheapest router is the 802.11b router, and it is slower than the 802.11a, 802.11g, 802.11ac, and 802.11n routers [29].

Standard	Frequency Band	Bandwidth	Modulation Scheme	Channel Arch.	Maximum Data Rate	Range	Max Transmit Power
802.11	2.4 GHz	20 MHz	BPSK to 256-QAM	DSSS, FHSS	2 Mbps	20 m	100 mW
b	2.4 GHz	21 MHz	BPSK to 256-QAM	CCK, DSSS	11 Mbps	35 m	100 mW
a	5 GHz	22 MHz	BPSK to 256-QAM	OFDM	54 Mbps	35 m	100 mW
g	2.4 GHz	23 MHz	BPSK to 256-QAM	DSSS, OFDM	54 Mbps	70 m	100 mW
n	2.4 GHz, 5 GHz	24 MHz and 40 MHz	BPSK to 256-QAM	OFDM	600 Mbps	70 m	100 mW
ac	5 GHz	20, 40, 80, 80+80=160 MHz	BPSK to 256-QAM	OFDM	6.93 Gbps	35 m	160 mW
ad	60 GHz	2.16 GHz	BPSK to 64-QAM	SC, OFDM	6.76 Gbps	10 m	10 mW
af	54-790 MHz	6, 7, and 8 MHz	BPSK to 256-QAM	SC, OFDM	26.7 Mbps	>1km ?	100 mW
ah	900 MHz	1, 2, 4, 8, and 16 MHz	BPSK to 256-QAM	SC, OFDM	40 Mbps	1 km	100 mW

*Figure 31: Breakdown of IEEE 802.11 Common Wi-Fi Standards  
Reprinted with permission from Endeavor Media/Microwaves&RF*

Most routers allow you to customize the SSID (the name of the network), the channel the router uses (channel 6 is the default option on the 2.4 GHz band), and the security options (if the Wi-Fi network is publicly available, or if it is secured with a username and password). The Wired Equivalency Privacy (WEP) security measure used to be the standard security algorithm for IEEE 802.11 wireless networks, and it was intended to provide security in computing on a similar level to that of a traditional wired network. However, WEP security proved to be weak after hackers discovered how to crack a WEP protected network [[https://en.wikipedia.org/wiki/Wired\\_Equivalent\\_Privacy](https://en.wikipedia.org/wiki/Wired_Equivalent_Privacy)]. As a result of the vulnerability of WEP security, WPA- or Wi-Fi Protected Access- and WPA2 have been developed to provide increased security to wireless networks. These standards use TKIP (Temporal Key Integrity Protocol) encryption, which is an improvement from WEP security, however TKIP is now deprecated and is not considered secure anymore. The strongest and most robust data encryption standard available today is AES, also known as Advanced Encryption Standard. The AES standard has been adopted by the US government, and it is also used by the WPA2 standard. [31].

For security reasons, an access point must have an established connection with a device before data can be sent through it. IEEE 802.11 defines three connection states: Unauthenticated and Unassociated, Authenticated, Unassociated, and Authenticated, Associated. A device must pass through all three states in order to form a complete association with a particular access point [33], which is done by exchanging a series of 802.11 management frames. A device starts off in Unauthenticated and Unassociated, which is the first state of authentication. The next steps for establishing a connection are listed below [32] and are shown in Figure 32:



*Figure 32: Wi-Fi Connection Process. Pending Approval*

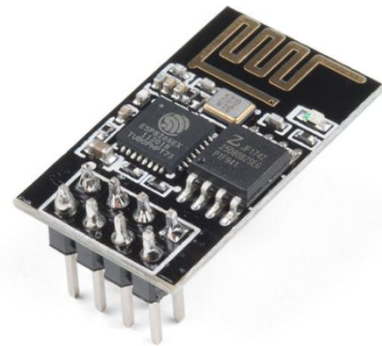
- 1) **Probe Request:** A device sends out probe requests to find any 802.11 networks that are in range.
- 2) **Probe Response:** The access point receives a probe request from a device, and it checks for at least one common supported data rate with the device. If found, the probe responds to the device with the SSID, support data rates, encryption types (if applicable), and other 802.11 capabilities.
- 3) **Authentication Request:** The device receives the probe response, and it selects a SSID/network. The device also checks the compatibility of the encryption types. If a compatible network is found, the device will send a low-level 802.11 authentication frame to the access point, which results in the authentication being set to open and its sequence set to 0x0001.

- 4) **Authentication Response:** The access point acknowledges the authentication frame sent by the device. If the authentication is successful, the access point will send an authentication sequence to the device, putting the device in an authenticated and unassociated state. Otherwise, it will respond with a deauthentication frame, which would place the device in an unauthenticated and unassociated state.
- 5) **Association Request:** An association request is sent by the device after it has been authenticated- it contains information such as the chosen encryption type and other 802.11 capabilities.
- 6) **Association Response:** The association request is acknowledged by the access point, and it sends an association response back to the device. If the association is successful, the response frame will contain the status code for success. Otherwise, if the status code is not successful, the device becomes deauthenticated.
- 7) **Data:** The device has successfully passed through the three connection states and is now in the success state- authenticated and associated. At this point, the connection between the device and access point is established, and data transfer can occur.

## Comparison of Wi-Fi Modules

### 1) ESP8266

The ESP8266 Wi-Fi Module, shown in Figure 33, is a system on a chip (also known as SOC), which means it is an integrated circuit that contains all the components of a computer. SOCs generally consist of a CPU, secondary storage, memory, I/O ports, as well as digital/analog/radio signal frequency processing functions. In the case of the ESP8266 Wi-Fi Module, it features 802.11 b/g/n, Wi-Fi Direct (P2P), soft-AP, an integrated TCP/IP protocol stack, a low power 32-bit CPU that can be used as an application processor, 1MB of flash memory, as well as SPI, I2C, and UART capabilities [34]. The ESP8266 is compatible with any microcontroller and can provide a microcontroller with access to a Wi-Fi network. It can connect to networks of varying security, including open, WEP, WPA and WPA2 networks [35]. The maximum data transfer rate is 72.2Mbps using a 2.4 GHz band. This module can be used to host an application, or it can be used to offload Wi-Fi networking functions from another application processor.



*Figure 33: ESP8266.  
Licensed under CC by 2.0*

The ESP8266 can be integrated with sensors and other application-specific devices through its GPIOs, and it also supports Bluetooth co-existence interfaces and APSD for VoIP applications. Regarding the power supply, it runs on VCC-3.0-3.6 Volts, and draws an average current of 80 mA. However, the ESP8266 is not capable of 5-3V logic shifting, and therefore needs an external Logic Level Converter. The



ESP8266 can work under all operating conditions and does not require external RF parts, since it contains a self-calibrated RF. With a cost of \$6.95, the ESP8266 is a very cost-effective module, making it a competitive option for a Wi-Fi module. Equally important, the ESP8266 also has a large community of users, so there is a wealth of resources and support available online to help us in using the module. The ESP8266 can be integrated with sensors and other application specific devices through its GPIOs, and it also supports Bluetooth co-existence interfaces and APSD for VoIP applications. Regarding the power supply, it runs on VCC-3.0-3.6 Volts, and draws an average current of 80 mA. However, the ESP8266 is not capable of 5-3V logic shifting, and therefore needs an external Logic Level Converter. The ESP8266 can work under all operating conditions and does not require external RF parts, since it contains a self-calibrated RF. With a cost of \$6.95, the ESP8266 is a very cost-effective module, making it a competitive option for a Wi-Fi module. Equally important, the ESP8266 also has a large community of users, so there is a wealth of resources and support available online to help us in using the module. After collecting information on each Wi-Fi module, we have decided to select the ESP8266-01 as for GRAD.

## 2) CC3120 TI SimpleLink Wi-Fi Network Processor



*Figure 34: CC3120 TI Processor. Reprinted with permission from ti.com*

The second option for a Wi-Fi module is the CC3120 SimpleLink Wi-Fi Network Processor, produced by Texas Instruments, shown in Figure 34. This subsystem also contains embedded TCP/IP, embedded TLS/SSL stacks, an HTTP server, and a multitude of Internet protocols. As part of TI's second generation of SimpleLink Wi-Fi, the CC3120 introduces upgrades such as support for a RESTful API using an internal HTTP server. Moreover, UART and SPI can be configured with this device. Regarding power consumption, the CC3120 requires between 2.1 V and 3.6 V to run, with typical current consumption in the milliamp and microamp range. Compared to the ESP8266, the CC3120's data rate is much lower with a maximum of 16 Mbps throughput. The cost for the CC3120 is \$5.02, and it can be purchased directly from the Texas Instruments website. <sup>TM</sup> microcontroller platform. The ROM of the CC3120R implements the Wi-Fi and Internet protocols, which runs from the on-chip ARM Cortex-M3 network processor and offloads a number of networking activities from the application MCU. Any microcontroller can be connected to this device to enable the microcontroller to access Wi-Fi or the Internet of Things (IoT) cloud. Some other important technical specifications of the CC3120 include: 802.11b/g/n radio, secure internet connection with 256-bit encryption, power saving low power modes, different Wi-Fi modes (station, AP, and Wi-Fi direct) and various supported protocols (WPA2 Personal and Enterprise Security: WEP, WPA/WPA2 PSK,

WPA2 Enterprise (802.1x)) [36]. This subsystem also contains embedded TCP/IP, embedded TLS/SSL stacks, an HTTP server, and a multitude of Internet protocols. As part of TI's second generation of SimpleLink Wi-Fi, the CC3120 introduces upgrades such as support for a RESTful API using an internal HTTP server. Moreover, UART and SPI can be configured with this device. Regarding power consumption, the CC3120 requires between 2.1 V and 3.6 V to run, with typical current consumption in the milliamp and microamp range. Compared to the ESP8266, the CC3120's data rate is much lower with a maximum of 16 Mbps throughput. The cost for the CC3120 is \$5.02, and it can be purchased directly from the Texas Instruments website.

### 3) **Geekworm NVIDIA Jetson Nano Wi-Fi Adapter**

The NVIDIA Jetson Nano Wi-Fi Adapter, shown below in Figure 35, can be connected to the NVIDIA Jetson developer kit to provide it access to Wi-Fi. It is a dual-band adapter with a data transfer rate of 1200 Mbps. Connecting the adapter to the board is made simple by plugging it into the NVIDIA's USB 3.0 port- so no soldering is necessary to integrate the adapter to the developer kit. However, it is necessary to install the driver for the adapter before it can be used with the developer kit. The NVIDIA Jetson Nano Wi-Fi Adapter supports the IEEE 802.11 a/b/g/n/ac protocols using 2.4 GHz or 5 GHz frequency bands. It also comes equipped with 64/128 bit WEP, and WPA-PSK/WPA2-PSK wireless security measures[37]. The adapter is compatible with some of the most popular operating systems, including Windows XP/vista/7/8/10, Linux2.6, Ubuntu, and Mac OS X. The hardware features a 5dBi sma antenna and a Realtek RTL8812BU chipset. The cost for the NVIDIA Jetson Nano Wi-Fi Adapter is \$18.99, and it can be purchased directly from the Geekworm website.



*Figure 35: NVIDIA Jetson Nano Wi-Fi Adapter.  
Reprinted with permission from geekworm.com.*

The Wi-Fi adapter contains a Realtek RTL8812BU chipset and is easy to use, only requiring two steps: plugging in and installing the driver. The Wi-Fi adapter uses a 5 dBi SMA antenna. It uses DBPSK, DQPSK, CCK, OFDM, 16-QAM, 65-QAM modulation technology. The Jetson Wi-Fi adapter transmits power less than 20 dBm.

## Bluetooth Technology

### Overview

Bluetooth technology, also known as IEEE 802.15.1, is a wireless technology standard that is used for exchanging information between Bluetooth-compatible devices. Similar to Wi-Fi, Bluetooth uses radio waves as a medium for exchanging information. Bluetooth communicates on a frequency of 2.4 GHz (or 2400 to 2483.5 MHz, to be more precise), which falls under one of the frequencies set aside by international agreement for ISM devices- also known as industrial, scientific, and medical devices [38]. Using the 2.4 GHz ISM band is advantageous in that it is available worldwide and it provides a good balance between range and data throughput- making Bluetooth a popular option for wirelessly connecting low-power devices over a short range.

Bluetooth uses frequency hopping spread spectrum (FHSS) technology for transmissions to avoid interference issues that arise due to other technologies using the same frequency band (for example, the 802.11b/g/n wireless local area network, or WLAN, standard). Within the 2.4 GHz ISM band, Bluetooth uses a total of 79 radio frequency channels, starting with 2402 MHz and with an interval of 1 MHz. This is the range of frequencies that Bluetooth “hops”, or changes, over. An illustration of FHSS technology in the ISM Band is shown below in Figure 36, with the bad channels indicating the presence of a co-existing WLAN channel [39]. Bluetooth changes frequency at different rates depending on the type of transmission: it changes at 1600 times per second for data/voice links, and 3200 times per second for page/inquiry scanning [41]. Each channel is visited for a short amount of time- for instance, for data/voice links the time period layover is 625 microseconds before hopping to the next channel in a pre-determined, pseudo-random sequence.

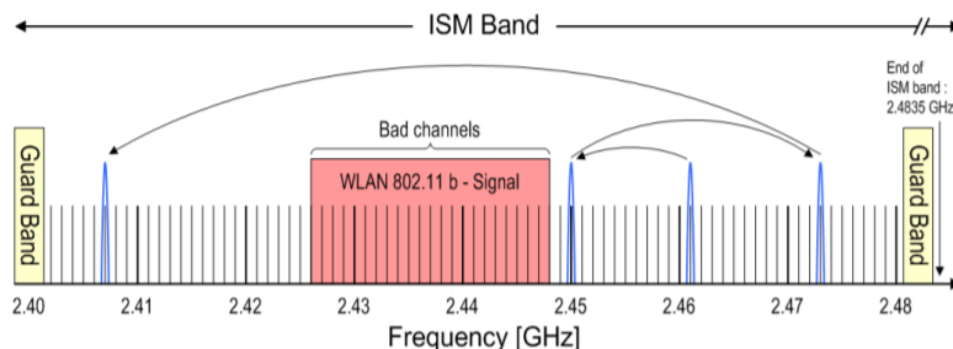


Figure 36: FHSS Example in the ISM Band

A Bluetooth device can connect with a minimum of one other device and a maximum of seven other devices in a personal-area network (PAN), also known as a “piconet.” Therefore, Bluetooth consists of a single master device and up to seven slave devices, and each device may be a member of different piconets at the same time. After a piconet is established, each connected device employs FHSS technology to hop frequencies in unison and remain connected with one another. Because Bluetooth uses FHSS technology, the likelihood that two transmitters will be on the same frequency at the same time is very small. FHSS technology also minimizes the chances of other devices interfering with Bluetooth connections, since any interference at a particular frequency would only last for about a fraction of a second [40].

Another characteristic of Bluetooth technology is that it provides for radio link power control, which allows each device to optionally vary its transmitted power. Devices with this capability can conserve power, and they can also maintain a preferred range of received signals. Radio power adjustments are made according to received signal strength measurements, or RSSI- each device in a network can measure its own RSSI and request that other devices in the network increase/decrease their radio power levels to match its own. The combination of FHSS technology and radio link power control provides Bluetooth with some protection against spying and remote access. Although the frequency-hopping scheme is mainly used to avoid interference with other devices, it also makes it more difficult for devices with malicious intent to locate and capture Bluetooth transmission when compared to fixed-transmission technology [41].

## Bluetooth Power Classes

The range of Bluetooth is determined by the power of the transmitter, and the maximum distance that Bluetooth devices can transmit data over determines that device’s class. At the highest level, there are three main power classes of Bluetooth- class 1 is rated as the most powerful, and class three rated as the least powerful Table 15 [41], which is included below, describes some characteristics of the three classes of Bluetooth, including power rank, maximum power level, the range of operation, and applications.

Class	Power Rank	Maximum Power	Range of Operation	Applications
1	High	100 mW, or 20 dBm	~100 m, or 328.1 ft	Industrial use, access points, USB adapters
2	Medium	2.5 mW, or 4 dBm	~10m, or 32.8 ft	Mobile devices, smart card readers
3	Low	1 mW, or 0 dBm	~ 1m, or 3.3 ft	Bluetooth adapters

*Table 15: Comparison of Bluetooth Power Classes*

Class 1 devices can achieve a maximum power of 100 mW, while class 2 can reach 2.5 mW and class 3 maxes out at just 1 mW. Class 1 devices also have the longest communication range at 100 m, while class 2 devices can reach 10 m and class 3 can extend just 1 m out. As can be seen by the maximum power ratings and range of operation, Class 1 significantly outranks the other two classes. For all the benefits of Class 1, however, there is a cost for having a larger transmission range- power. Power may not be a problem if it is readily available- for instance, if devices can be plugged into nearby power outlets- however, power may not always be an accessible resource, which may pose a problem.

In the case of the GRAD system, it is supposed to run for hours without needing to be plugged back in for recharging, so the power consumption of Bluetooth is an important consideration. For the purposes of our project, the only option for Bluetooth that would satisfy the specifications of GRAD is Class 1, due to operating range considerations. The average length of a standard single-car driveway is 18 to 20 feet[42], so the minimum range for GRAD's communication system must be 20 feet plus the distance from the user's phone to an arbitrary point inside the user's home. Since the average length of a single-car driveway exceeds the maximum operating ranges of class 2 and class 3, that leaves class 1- with an operating range of 100 m- as the only viable option for Bluetooth, especially if we were to account for physical barriers or environmental factors that reduce the intended range of Bluetooth.

## Connection Process

A process known as Bluetooth pairing is used to easily and quickly connect devices together. Once Bluetooth pairing has occurred, data can be exchange between the devices. The details of the connection process are depicted in Figure 37 [43], and the steps for establishing a Bluetooth connection between devices is further explained below [44].

1. **Inquiry-** If two Bluetooth devices are pairing for the first time and have no information on each other, one device must run an inquiry to discover the other. When one device sends an inquiry request, the other device receives it and responds with its address.
2. **Paging (Connecting)-** In this stage, a connection is formed between the two devices. For this connection to occur, each device needs to know the address of the other- this information is retrieved during the inquiry process.
3. **Connection-** After the paging process is complete, it enters the connection state. There are four different connection modes: active mode, sniff mode, hold mode, and park mode. Each mode allows devices to adjust their power consumption, performance, and the role of each device in the piconet.
  - o **Active Mode:** Each device is actively participating in transmitting or receiving data- the master device continuously polls slave devices for transmissions in this regular connected mode [45].

- **Sniff Mode:** A slave device listens to the piconet, but only at a set interval of time (for example, 150 ms). This is a power-saving mode that reduces the duty cycle of the slave devices.
- **Hold Mode:** This is another power-saving mode in which a device sleeps for a set time interval and then returns back to the active mode. The master device can command a slave device to enter hold mode, or a slave device can request to enter hold mode. The hold mode has a lower duty cycle than the sniff mode.
- **Park Mode:** In this mode, a slave device is put to sleep until it is woken up by the master device. Park mode is the highest power-saving mode, and thus it has the lowest duty cycle of all the modes.

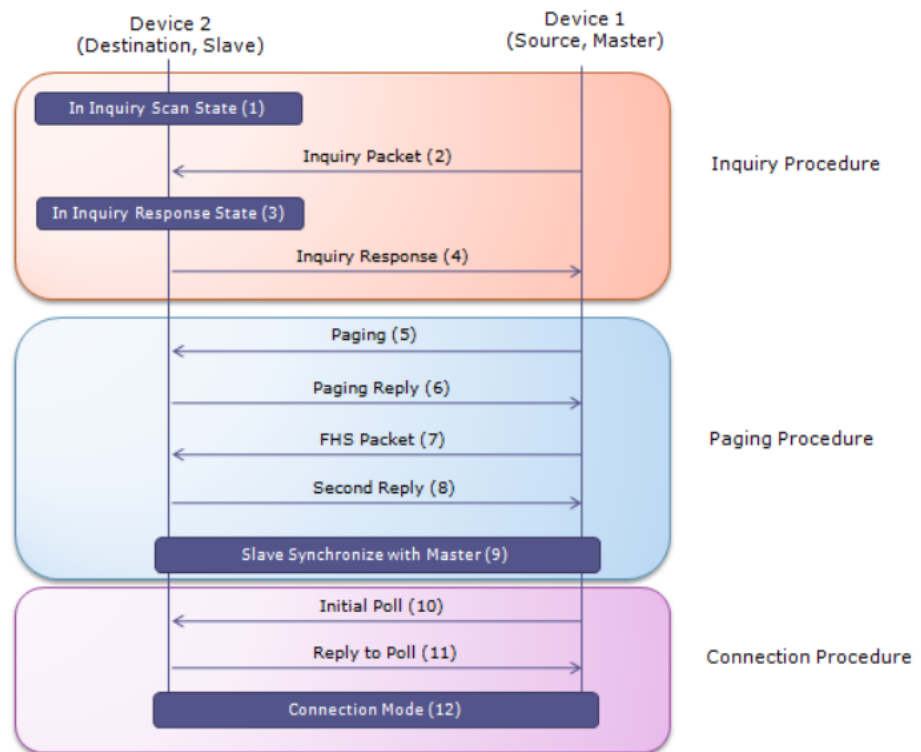


Figure 37: Bluetooth Connection Process.  
 Reprinted with permission from [www.sharetechnote.com](http://www.sharetechnote.com)

## Overall Comparison of Wireless Communication

In order to decide which form of wireless communication would be best suited for GRAD- Wi-Fi or Bluetooth- several characteristics were compared. The most important variable in comparing each wireless standard is the operating range, since GRAD must be able to access the database containing personalized information for each user during the entire time that it is transporting itself to the user's curb. GRAD must be able to retrieve

information stored in the database regarding the date and time to take out the trash (as specified by the user through the mobile/web application), and it must be able to add information into the database whenever it needs to send a notification to the user (for instance, if GRAD was unable to reach the user’s curb for any reason). Many other factors were considered in addition to range, as shown in Table 16 below. Other considerations included power consumption, size of network (number of supported devices), rate of data transmission, and security.

	Wi-Fi	Bluetooth Classic
<b>Standard</b>	IEEE 802.11b/g/n	IEEE 802.15.1
<b>Applications</b>	High speed access to the Internet	Small media transfers
<b>Frequency Band</b>	2.4 GHz, 5 GHz	2.4 GHz
<b>Number of RF Channels</b>	14 (2.4 GHz) 23 (5 GHz)	79
<b>Range</b>	20 m – 150 m	100 m (Class 1) / 10 m (Class 2)
<b>Power Consumption</b>	High	Medium
<b>Network Size (number of devices)</b>	255	1 master device, up to 7 slave devices
<b>Data Rate</b>	b: 11 Mbps/ g: 54 Mbps /n: 600 Mbps	1-3 Mbps
<b>Security</b>	WEP, WPA,WPA2, AES (More Secure)	Bluetooth Security Modes 1-4 (less secure)

*Table 16: Wireless Communication Comparison*

Since Wi-Fi has a larger range, better security measures, and a higher rate of data transmission than Bluetooth, we will be using a Wi-Fi module rather than a Bluetooth module to implement GRAD’s wireless communication system. Although Wi-Fi surpasses Bluetooth regarding speed, security, and range, it comes at a cost- it consumes more power and thus drains the battery life more quickly than Bluetooth. In particular, the Wi-Fi module that we will be using is the ESP8266 since it is one of the most widely used Wi-Fi module for microcontrollers. Since none of us have experience in using Wi-Fi modules, there will be a learning curve in figuring out how to use the ESP8266.

### 3.4.2 Path Planning

Path planning- or the process of driving a robot from a specified start point to a specified end point- is an integral part of GRAD. In order for GRAD to be autonomous, it must be able to distinguish free space from space with obstacles to avoid collisions with nearby objects and safely transport itself to the user's curb [46]. As stated in RS-07 and RS-14 in the Requirement Specifications Table, the trashcan robot must traverse a maximum distance of 500 feet and transport itself within five feet of the desired location. In addition, as stated in RS-09, the trashcan robot will work achieve an 85% rate of no obstacle collision. GRAD's path planning system must be carefully designed to meet these requirement specifications.

There are different types of path planning, and they are distinguished by the information available about the environment, for example: fully known/structured environment, partially known environment, and fully unknown/unstructured environment. In most practical applications of path planning, the environment is only partially known- which means that the robot is designed for exploratory purposes, or that the robot must travel from a start point to an end point without the help of a floorplan or terrain map. Current methods for navigating a robot in a partially-known or unknown environment involve planning an initial path based on known information, then making changes to the path as the robot discovers new obstacles with its sensors [47]. Path planning can be either local or global. In the case of global path planning, the environment is fully known, so the path planning algorithm can pre-compute a set path from the start and end points before the robot even starts moving. On the other hand, local path planning occurs on a smaller level and is performed after the robot has started moving and collecting information on the environment from its sensors. Figure 38 below illustrates how path planning will be used in our project- to drive GRAD from a start point to an end point while avoiding obstacles in its environment.

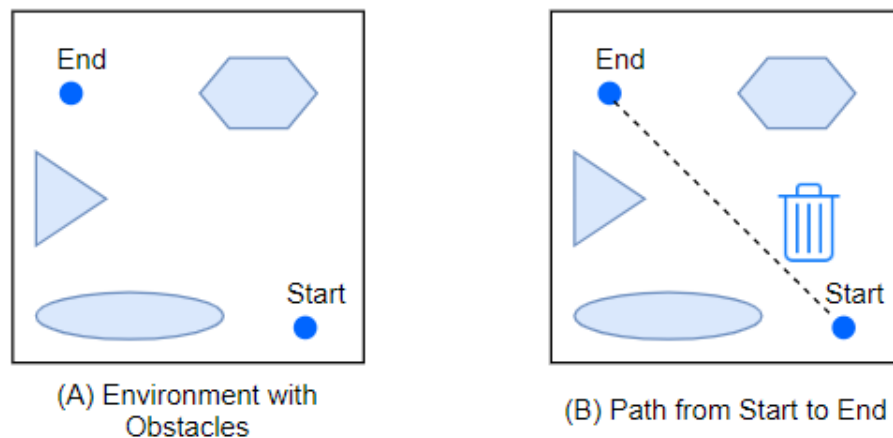


Figure 38: (A) Environment with obstacles (B) One possible path from start to goal

We are currently considering various methods of implementing path planning into our project including line following, GPS, and computer vision. A decision will be made after researching the required components, accuracy/precision, cost, complexity of algorithms,

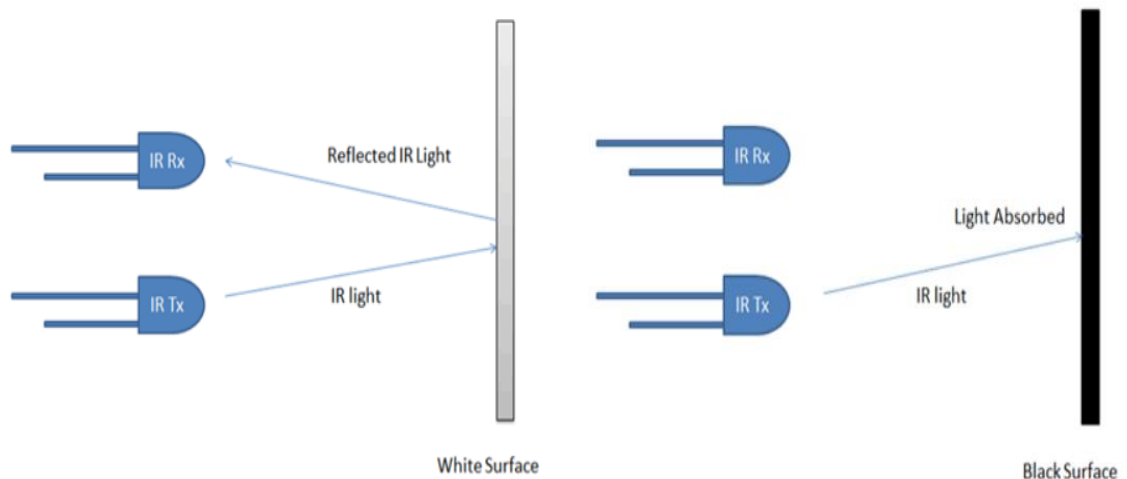


and implementation details for each method. The ideal path planning method for GRAD would be the one that is the easiest to implement while providing accuracy that satisfies the maximum allowed error of 5 feet.

## Line Following Robot

A line following robot is a machine that follows a line, usually a black line in a white background or a white line in a black background. Line following robots can distinguish the line from their background and run over it, hence the reason for choosing contrasting colors for the line and background. To incorporate line following into GRAD, the user would need to outline the desired path from their garage to the curb by placing tape on the ground that define the trashcan's path. In this case, the path planning environment is fully known since it is defined before the robot starts moving.

IR sensors- either two individual sensors or an array sensor- are commonly used to implement line following by calculating the reflectance of the surface beneath them, as shown below in Figure 39 [48]. A white line would almost completely reflect any light that falls on it, while a black line would absorb most of the light that falls onto it. The value of reflectance detected by IR sensors is used as a parameter to detect the position of the line. The IR sensors emit a light that strikes the surface of the line and is reflected back to the IR photodiode. The photodiode then responds by producing either a high or low value for output voltage (high for light surfaces, low for dark surfaces) proportional to the level of reflectance of a surface [49] Thus, the IR sensors allow the robot to “see” the line and notify the robot if any adjustments need to be made if it strays from the path. Line following robots estimate if the line beneath them is shifting too much to the right or left, and based on these estimations, it signals the motors to turn left or right in order to keep the line at the center of the robot.



*Figure 39: IR transmitters and receivers in line following.  
Reprinted with permission from circuitdigest.com*

### **3.4.3 Selection of Sensors**

In order to meet the specification requirements of the GRAD system, researching and choosing accurate sensors that would be the best for detecting and avoiding objects is crucial. The difficult task is to eliminate all the wrong choices for the sensors based on a series of interrogation that aims to eliminate the technology behind the sensors and then the product which is being built does not fit the requirements [50]. In this section, all types of sensors will be explored that are potentially used to detect objects. The GRAD system will require sensors that will be able to detect the level of waste in the trashcan which will be placed inside the lid of the trash can. Apart from the waste level detection in the trash can, the GRAD system will require more than one sensor. The other sensors will be placed on the front, back, left and right side of the trash can in order to detect any object near it. These sensors will be integrated into the GRAD navigation system in order to avoid obstacles.

In order to select or choose the best sensor from a variety of sensors available in the market, the sensor must be selected such that it will meet all the requirements for the GRAD system. Also, choosing accurate sensors for the GRAD system is important because of the reliability and perfection of the sensor that affects the performance of the GRAD system. There are different types of proximity sensors that are good at detecting the presence of an object. In this section different types of sensors used for obstacle or object detection is discussed.

#### **Infrared sensor**

An infrared sensor is one of the sensors used to detect an object by measuring the IR light that is transmitted in the environment. In other words, the infrared sensor is used as an object detector or obstacle detector by transmitting the infrared signal, and if this infrared signal bounces from the surface of the object that is present in the surrounding the signal is received at the infrared receiver indicating that there is an obstacle. The light from the infrared is emitted from the Infrared LED emitter.

Infrared sensors are used mostly in robots that require avoiding obstacles. Some applications of these sensors include distance measurement, edge detection, security system, human body detection, and counter devices. Infrared sensors are also used in smartphones in order to find the distance of the object by a principle known as Reflective Indirect Incidence. There are some advantages of infrared sensors, one of them being that the sensor does not require any contact with the object to be detected or sensed. These sensors are also good at measuring the distance to soft objects easily as compared to other sensors [51]

Even though infrared sensors seem to be a good choice for object detection it also has some disadvantages. The outdoor garbage bin might come across humans, animals or any other object while navigating itself to the curb and the infrared sensor has high power waves that can damage eyes [51]. Also, infrared sensors are compatible with longer distances which is a huge drawback for the outdoor garbage bin.

## **Lidar Sensor**

LIDAR – Light Imaging Detection and Ranging is a sensor that uses a laser in order to measure the distance of the object. Lidar sensor is also referred to as active laser scanning because it works remotely that can be used to detect an obstacle over a large region. The basic principle behind this sensor is that the light or laser signals are emitted from the sensor and the signals hit an obstacle, the signal reflects back from the obstacle and returns to the receiver triggering a laser pulse [52]. Lidar has a shorter wavelength which allows the detection of small obstacles. Lidar sensors are quite expensive. However, they have great accuracy in detecting and measuring the distance of an obstacle.

The advantage of using a Lidar sensor is that the sensor can be used in daylight as well as at nighttime. Also, the sensor has a great accuracy to collect data even in extreme weather conditions [52]. The outdoor garbage bin does not really require the measurement for the detection of an obstacle. The main purpose of the outdoor garbage bin is to just detect the obstacle which it might encounter when it navigates or drives itself to the curb. At this point, the team has not decided whether to use a computer vision for detecting an obstacle or just use simple sensors. Lidar sensors would be helpful if the team chooses to go with the computer vision idea however it will be expensive. Also, in order to use the lidar sensor the team must be very confident as these types of sensors are not easy to use.

Although lidar has some great advantages it also has some disadvantages. The Lidar sensor is not suitable for water surfaces as the data will not be accurate. The main disadvantage of this sensor is that the laser beams produced may affect the human eye.

## **RADAR Sensor**

RADAR which stands for Radio Detection and Ranging is a sensor that uses radio waves to detect an obstacle at a certain distance and also measures the speed of the object. The working principle behind a RADAR sensor is similar to an ultrasonic sensor, the only difference is that the ultrasonic sensor uses sound waves whereas the RADAR sensor uses radio waves. Moreover, the radio waves in a RADAR sensor like the ultrasonic sensor are undetectable to human beings to hear. Also, the speed of the radio waves and light waves are similar to each other [52].

RADAR sensors are used in many applications. These sensors are widely used in military purposes. Apart from military purposes, RADAR sensors that are installed in some aircraft help to measure other aircraft nearby and measure the attitude. Moreover, these sensors are also being used in the marine industry to detect any obstacle such as a rock or other ship nearby [52].

The advantage of using a RADAR sensor is that it is really helpful and precise in the longer distance. Furthermore, RADAR sensors are feasible to use in cloudy weather conditions and are precise to detect and measure the distance of the obstacle. Even though the RADAR sensor is accurate in detecting an obstacle, these sensors are quite more expensive than ultrasonic sensors [52].

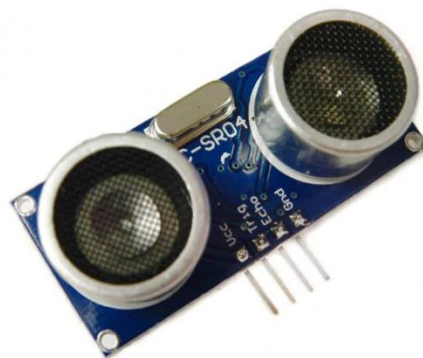
The outdoor garbage bin the team is designing does not require the measurement of the distance of the detected obstacle. RADAR sensors have a longer wavelength which does not make a good candidate for the outdoor garbage bin. The outdoor garbage bin uses solar power to charge itself and because the RADAR sensor requires a higher power consumption and the high cost the team decided not to use this sensor.

## Ultrasonic Sensor

An ultrasonic sensor is one of the sensors that measure the distance of an object by sending the soundwave of a specific frequency. The frequency is too high for humans to hear. The ultrasonic sensor waits for the sound waves to be reflected back when it detects an object and also calculates the distance based on the time required. Ultrasonic sensors are accurate in measuring short distances. The ultrasonic sensor comprises a transmitter that transmits the ultrasonic waves and a receiver that receives the ultrasonic waves, and both are operated at a specific and same frequency.

Ultrasonic sensors have some advantages. Ultrasonic sensors can detect objects easily because of high frequency. They are also easily compatible with microcontrollers. Everybody considers safety as a priority, these ultrasonic sensors are feasible to use also they are not dangerous and do not harm any person, object or material nearby it [53].

Ultrasonic sensors are used in many applications such as level detection on water, milk, chemical or oil in order to measure the liquid level control. Ultrasonic sensors are also widely used in the robotic industry, car washing systems for washing and detecting the car [53]. In the GRAD system, the main purpose of using ultrasonic sensors is to detect an object nearby. The ultrasonic sensor the team is planning to use is HC -SR04 shown in figure 40 below.



*Figure 40: HC SR04 ultrasonic sensor. Reprinted with permission from thepihut.com*

## Ultrasonic Sensor Theory

As shown in figure 1, the HC-SR04 ultrasonic sensor has 4 pins and 2 round shaped openings. One opening of the sensor acts like a speaker that sends or transmits soundwaves and the other opening receives the soundwave back when it encounters an object within its

range. The 4 pins consist of GND (Ground), Echo (Echo Pulse Output), Trig (Trigger Pulse Input) and VCC (5V supply). The ultrasonic sensor will be integrated with a microcontroller (typically Arduino or Raspberry Pi, depending on the approach the team decides). The main advantage of this ultrasonic sensor is that it is compatible with both Arduino and Raspberry Pi microcontroller which makes it easier for the team to decide which microcontroller among these two we will be using. The ultrasonic sensors are very reliable in indoor as well as outdoor environments. The comparison between different types of sensors required for the GRAD system is discussed in Table 7.

Features	Infrared Sensor	Ultrasonic Sensor
<b>The range for detecting an object</b>	Detects objects which are closer than 10mm.	Detects objects which are 1 m away from the sensor. Has more detection range than infrared sensor
<b>Interference of natural light</b>	Very sensitive to sunlight and not good for outdoors	Insensitive to light, dust smoke, color and good for outdoors
<b>Accuracy in detecting an object</b>	Not completely accurate and reliable. Helpful only to know if an object is present.	More reliable and provides more accurate data of the distance of the object
<b>Cost</b>	Cheaper in price	Not cheaper

Table 17: Comparison of Sensors [54]

The team will be using ultrasonic sensors in order to detect an obstacle as the sensor is cheap and the working principle behind it is easy to understand. A simple figure illustrating how ultrasonic sensor works is shown in the figure.

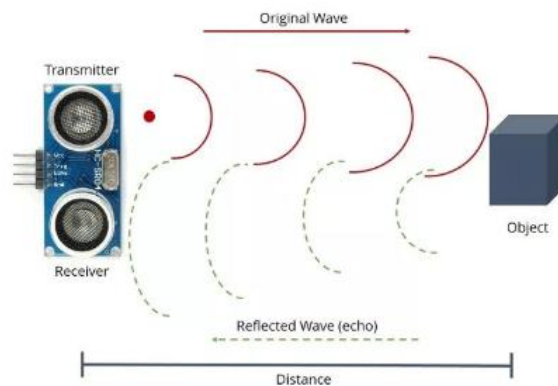


Figure 41: Working principle of the ultrasonic sensor. Pending Approval

### 3.4.4 Camera

In this section, different types of cameras required for obstacle avoidance will be discussed. In order to meet the specification requirements of the outdoor garbage bin system, researching and choosing a precise camera that would be the best for avoiding obstacles with the help of computer vision to navigate the outdoor garbage bin safely and smoothly to the curb. The choice of the camera being selected is crucial as it affects the success of the outdoor garbage bin system. A brief explanation of each camera available in the market will be discussed and accordingly, the best camera that would match the requirement for the outdoor garbage bin system will be explored more in-depth.

The outdoor garbage bin requires a camera so that it can navigate itself from its starting position to the destination position avoiding all the obstacles nearby it. A path planning algorithm using line following will be required to navigate the trash bin. The camera selected will help with the implementation of a path planning algorithm with avoiding obstacles using computer vision.

#### Raspberry Pi Camera V2

The Raspberry Pi camera module V2 is a product manufactured by the Raspberry Pi Foundation. The Raspberry Pi camera module V2 has a high 8-megapixel resolution with a fixed focus lens. The camera is fixed on a tiny board with around 25 x 24 x 9 mm size and weighs around 3g that makes it feasible for smartphones and other small applications. The Raspberry Pi Camera module V2 has amazing specifications. The Raspberry Pi Camera module V2 supports 1080p at 30 frames/sec, 720p at 60 frames/sec and 640x480p60/90 video modes. The Raspberry Pi Camera V2 has a high-quality Sony IMX219 sensor with 3280 x 2646-pixel resolution and a 3.68 x 2.76mm sensor image area. It can easily be connected to the microcontroller Raspberry Pi by a short ribbon cable [55].

The Raspberry Pi camera module V2 is very popular and in demand, because it is cheap and easy to use for beginners who want to gain knowledge on using this product. One of the applications of the Raspberry Pi camera module V2 is home security. The Raspberry Pi camera V2 has a drawback that it does not work in dark places such as nighttime.



*Figure 42: Raspberry Pi Camera Module V2.  
Reprinted with permission of thepihut.com*

## Raspberry Pi NoIR Camera Module V2

The Raspberry Pi NoIR Camera Module V2 has similar specifications as the Raspberry Pi Camera module V2. The Raspberry Pi NoIR camera module V2 also has an 8-megapixel resolution with a fixed focus lens. Moreover, like Raspberry Pi NoIR camera module V2 is specially designed for high-quality videos and pictures so that it can be used in different types of applications. The Raspberry Pi NoIR Camera Module V2 is compatible with Raspberry Pi and can be attached to Raspberry Pi by a small socket on the Raspberry Pi board. The dimensions and weight of the Raspberry Pi NoIR Camera Module V2 is the same as the Raspberry Pi NoIR Camera Module V2. The only difference between Raspberry Pi NoIR Camera Module V2 and Raspberry Pi Camera Module V2 is that the NoIR camera module specially designed for better pictures and video in the low light environment and also for capturing infrared photography the NoIR camera has no Infrared filter [56].

The Raspberry Pi NoIR Camera Module V2 captures better quality pictures and videos in the low light environment which makes it a good product for applications like drones used in the night time, night surveillance systems, keeping tracking of plant growth and for other security systems [57]. The Raspberry Pi NoIR Camera Module V2 cost the same as the Raspberry Pi Camera Module V2.



*Figure 43: Raspberry Pi NoIR Camera Module V2.  
Reprinted with permission of pishop.us*

## Pixy2 CMUcam5

The Pixy2 CMUcam5 camera detects and tracks objects rapidly nearby it. Pixy2 is the latest version of Pixy with more features than older Pixy. Pixy2 is small, feasible and if you press a button the Pixy2 will be able to detect objects that you teach it. This involves computer vision knowledge and more information about computer vision will be discussed in another section. Pixy2 includes new features such as algorithms that detect and track lines with the help of line following robots that weren't available in the older version of Pixy. The new algorithms are helpful and rapidly tell the robot to detect intersections and road signs such as turning right, left or slowing down itself [58].

The Pixy2 CMUcam5 has a dimension of 1.5 x 1.65 x 0.6 inches and weighs about 10g which makes it small and light-weighted. The Pixy2 CMUcam5 has an integrated light source and the frame rate is 60 frames per second which means that the user gets an entire update of all detected objects positions within its range every 16.7 ms. This makes the robot move or drive faster. The Pixy2 CMUcam5 is compatible with Arduino, Raspberry Pi, LEGO Mindstorms EV3 and other similar microcontrollers. Based on the microcontroller the user chooses the Pixy2 CMUcam5 communicates through one of the interfaces that include SPI, UART, I2C, USB or digital/analog output. Moreover, all libraries for the microcontroller are provided. The Pixy2 CMUcam5 has a processor NXP LPC4330 with dual-core and 204 Mz. The Pixy2 CMUcam5 can be programmed in a variety of software programming languages such as C++/C and Python [58]. The Pixy2 CMUcam5 supports 40 degrees vertical and 60 degrees horizontal lens field of view [59].

The Pixy2 CMUcam5 is the best camera for tracking and detecting objects. For instance, if you want to teach Pixy2 to learn about a blue ball then you have to simply place the blue ball in front of the Pixy2 camera and then press the button on the Pixy2. Once the Pixy2 learns the object when you bring the blue ball in front of the Pixy2 the LED turns blue. When the button is released the Pixy2 generates a statistical model of the colors within the blue ball and it stores it. However, the Pixy2 CMUcam5 camera is expensive because of the variety of features. The Pixy2 CMUcam5 uses an algorithm that is color based to detect and track certain objects [58]. The Pixy2 CMUcam5 can be used to create a robot that performs several tasks like following certain objects, locating a specific location by having a sign or flag on it. The Figure 44 & 45 is reprinted with the permission of sparkfun.com.



*Figure 45: Front View of Pixy2CMUcam5*      *Figure 44: Back View of Pixy2CMUcam5*

### **Raspberry Pi Night Vision Camera with Fisheye 160 ° Lens**

The Raspberry Pi Night Vision Camera delivers a crystal clear 5 Megapixel resolution image. The Raspberry Pi Night Vision Camera has a unique feature that makes it different from the normal Raspberry Pi camera. The Raspberry Pi Night Vision Camera has two high-intensity Infrared LED spotlights that turn on automatically in the low light environment. The Raspberry Pi Night Vision camera captures a better view of its surroundings when it is dark and is a good camera for nighttime recording. The name of Raspberry Pi Night Vision Camera itself suggests that it is a night vision camera.



The Raspberry Pi Night Vision has a 3.6mm adjustable focal length lens and a diagonal degree viewing angle of 160 and 120 horizontally. This camera has an HD resolution of 1080p at 30 frames per second which delivers a great quality nighttime video. The Raspberry Pi Night Vision Camera has two Infrared LED spotlights and those LEDs get power from the CSI port allowing them to light up when it is dark for up to a distance of 8m. The Raspberry Pi Night Vision camera has an onboard photoresistor to detect light in its surroundings so that if it is dark the infrared LEDs turn on. The weight and dimension of the Raspberry Pi Night Vision are 0.8-ounce approx., and 25mm x 24mm respectively [60]. It is not as lightweight as other Raspberry Pi cameras. Also, it provides 3.3 V of a power outlet. The Raspberry Pi Night Vision camera costs \$33 currently which is still not bad as compared to the Pixy2 CMUcam5.

The Raspberry Pi Night Vision camera is compatible with all the versions of Raspberry Pi. The Raspberry Pi Night Vision Camera is an excellent camera product if the robot wants to identify and capture images or videos at night time because of its cool features.



*Figure 46: Raspberry Pi Night Vision Camera with Fisheye 160 ° Lens.  
Reprinted with permission from thepihut.com*

### **Logitech HD Webcam C525**

The Logitech HD Webcam C525 has a high-resolution of 1280 x 720 pixels. The Logitech Webcam is the best sensor among the other digital cameras with the USB 2.0 port. The Logitech HD Webcam C525 delivers 720 pixels resolution for capturing video. The Logitech HD Webcam is designed to be a portable and fold-and-go webcam that can easily be carried anywhere. Moreover, the weight and dimension of the webcam are 5.3 ounces and 8.2 x 3 x 6 inches respectively. The Logitech HD Webcam C525 has a lot of features including HD light corrections that turn the lighting conditions in order to deliver better quality brighter images if the background is low light [61]. Also, the webcam delivers a smooth quality of the video at 30 frames per second.

Unfortunately, due to the weight of the Logitech HD webcam, the team decided not to choose this product for the outdoor garbage bin. Also, the Logitech HD Webcam C525 does not meet all the specifications and requirements for the outdoor garbage bin. Furthermore, if the Logitech HD Webcam C525 is connected to Raspberry Pi microcontroller via USB 2.0 Port, likely, it will not deliver better quality video or images. The Logitech HD Webcam C525 figure is shown below with the permission of Sparkfun.



*Figure 47: Logitech HD Webcam C525. Pending Approval*

### **Intel RealSense Depth Camera D415**

The Intel® RealSense™ D415 is an amazing camera for accuracy. The Intel® RealSense™ D415 has a vast number of features. The specification of this camera is fascinating and is used in robotics. The Intel® RealSense™ D415 can be used indoors as well as outdoors. This feature in the Intel® RealSense™ D415 is useful for the outdoor garbage system. Also, in the future, the team might decide to create an autonomous indoor garbage system allowing this camera to be a very good candidate. The Intel® RealSense™ D415 is equipped with the depth sensors and has up to 1280 x 720 active stereo depth resolution and a frame rate of 90 frames per second. This depth camera uses stereo vision for calculating depth. The Intel® RealSense™ D415 has  $(65^{\circ}\pm 2^{\circ} \times 40^{\circ}\pm 1^{\circ} \times 72^{\circ}\pm 2^{\circ})$  depth of field view [96]. Furthermore, the Intel® RealSense™ D415 has an advanced stereo depth algorithm for accurate depth perception and long-distance range.

The Intel® RealSense™ D415 is a great camera for 3D scanning, facial detection or capturing a film in 3D for viewing in virtual reality. The Intel® RealSense™ D415 is used in many applications such as drones, robots, home or bank surveillance, etc. The Intel® RealSense™ D415 has an integrated RGB sensor that has up to 1920 x 1080 RGB resolution. The RGB sensor is useful if you are trying to train object recognition software with color images. This camera also has a dual rolling shutter sensor for up to 90 frames per second depth streaming [96]. The Intel® RealSense™ D415 can be connected to Raspberry Pi via USB port. The cost of the Intel® RealSense™ D415 is high compared to the other cameras because it offers a variety of features.



*Figure 48: Intel® RealSense™ D415. Reprinted with permission of sparkfun.com*

Camera	Raspberry Pi camera module V2	Pixy2 CMUcam5	Raspberry Pi Night Vision Camera	Intel® RealSense™ D415
Dimensions	25 x 23 x 9mm	43 x 39 x 16mm	25 x 24mm	99 x 20 x 23mm
Weight	3g	10g	23g	72g
Resolutions	-8MP still resolution - HD quality Sony IMX219 sensor with 3280 x 2646 pixel resolution	-Aptina MT9M114 Image sensor with 1296 x 976 resolution	-5 Megapixel resolution image -1080P sensor resolution	-1280 x 720 active stereo depth resolution - RGB sensor that has up to 1920 x 1080 resolution
Key Specifications	- Compatible with Raspberry Pi models - Great images captured in a good lighting environment	-Compatible with Arduino, Raspberry Pi, LEGO Mindstorms EV3 - Detects and tracks lines	-Compatible with Raspberry Pi - Equipped with two Infrared LED spotlights - Night vision compatibility	-Compatible with Raspberry Pi - Has advanced stereo depth algorithm - Has a dual rolling shutter sensor
Cost	\$29.95	\$59.95	\$33	\$199.95

*Table 18: Camera Comparison*

After analyzing different types of cameras, the best camera for the outdoor garbage bin system would be Pixy2 CMUcam5 because of the great features the camera provides. Also, the Pixy2 CMUcam5 camera is compatible with a variety of microcontrollers, so if the team decides to switch to any other microcontroller it will not be a problem. Since the Pixy2 CMUcam5 meets all the specifications for the outdoor garbage bin the team will choose Pixy2 CMUcam5 if the team decides to do computer vision.

The team decided not to choose computer vision for path planning for the GRAD system. Hence, **the team decided not to utilize any camera for the GRAD system.** An infrared sensor for path planning was chosen as an alternative. The final decision about the parts that are selected is discussed in the conclusion section of this document.

## **Software Development**

Software engineering is a dynamic process that involves designing, developing, and testing computer software applications that meet the needs of end-users and customers. Developing software solutions to solve complex problems is accomplished by 1) analysis, which is splitting one large problem into several smaller sub-problems that are more easily solved, and 2) synthesis, which is composing smaller software components together into one unified component. To develop quality software, software engineers must consider the perspectives of the end user and the manufacturer- for instance, users determine the quality of software based on its functionality and smooth operation (minimal number of failures) while manufacturers also consider how cost-effective the solution is. Therefore, software engineers must integrate the user's external views and developer's internal views to deliver the best possible solution to a problem. Even after the completion of a product, the software is not really done since unexpected faults and failures may be discovered by the end user that require fixing.

Software development is a very crucial part for the development of the autonomous outdoor garbage bin. The main task of the autonomous outdoor garbage bin is to navigate itself to the curb when the user tells it to. In order to make that happen path planning, algorithms have to be implemented. It is important to decide on how the software will be developed for this project work. The autonomous outdoor garbage system also requires an app that will be connected through the Wi-Fi or Bluetooth module. Therefore, software development will also be needed for app development. In this section, all the software development utilized in this project will be discussed.

## **3.5 Programming Architecture**

### **3.5.1 Programming Languages**

In this section, different types of programming languages will be discussed that are potentially used for obstacle avoidance and path planning. Depending upon which path planning algorithm and the microcontroller the team chooses, the programming language which is compatible for both will be utilized. The team needs to know the programming language that will be utilized in this project. The programming languages the team will be utilizing for the mobile application development is the most important part of this project. The most widely used programming languages used in the industry are discussed below.

#### **C++ Programming Language**

C++ is an object-oriented programming language that is basically an extension of C language. In simple words, C++ is a superset of C. The reason why C++ is called an extension of C language because before it was called "C with classes" as it had the concept of classes and consisted of all the basic properties of the C programming language [63]. Both C and C++ programming languages use similar syntax with few changes. C++ supports multiple inheritance and header files. All the team members working on this project are familiar and have good knowledge about the C++ programming language

because this is an easy programming language to learn as beginners. It is easier to learn and understand other object-oriented programming languages such as Java and Python once you get familiar with the C++ programming language. C++ programming language is still being used widely in the software and hardware industry.

### **Java Programming Language**

Java is also an object-oriented programming language. Java is one of the most commonly used and great programming languages. Java programming language is an improved version of C++ programming language that is strong and easy to use. Java programming language is used for Android app development. Therefore, this is the reason the team will be using Java for developing the app for the outdoor garbage bin. The main advantage of the Java programming language is that Java code can run on all software platforms that potentially support Java without the requirement of recompilation. Therefore, Java is platform-independent [62]. Java does not support header files like C++, instead, it uses the import keyword to include classes. Furthermore, Java programming language automatically manages the memory so that the user does not have to worry about the memory like in C. However, Java programming language is slower compared to C++.

### **C Programming Language**

C is one of the oldest programming languages. C programming language is also a base language for several other programming languages that means that once we have the knowledge of how to code in C language it will help us to study and learn other programming languages. As discussed in the section above, Java and C++ are developed from C programming language [64]. C programming language is widely used in the implementation of the embedded system. Moreover, C is also utilized in developing operating systems. Memory management in C is very important and is not easy compared to Java. The team will be using C programming language for hardware development. The microcontrollers support C programming language. Also, all the team members are familiar with C programming language.

### **Python Programming Language**

Python is also an object-oriented programming language like C++ and Java. Currently, Python is the most trending and widely used programming language in the industry. Python programming language is the best known and well-support language for machine learning. Python programming languages comprise a vast number of libraries for machine learning which helps the programmers to code easily. For this reason, Python programming language is used in Image processing, Scientific computing, GUI application, etc. Python programming language is easier to learn if a person has some knowledge about programming. The only drawback of Python is that is slower than C++ and Java. Python is an interpreted, high-level programming language [65]. The reason why Python is easier because it has a similar syntax to the English language. It is easier for beginners to learn the Python programming language because of its simplicity. Also, memory management is not an issue in Python like C. The user can code in a few lines in Python than C/ Java / C++. The most important thing in the Python programming language is indentation.

The programming language selection for hardware development will depend on the microcontroller the team chooses. If the team chooses to go with the computer vision technique for obstacle avoidance, then Python programming language will be a good candidate because it has a vast number of open source modules and is free to use. Moreover, Python is a well-known programming language for computer vision.

## Mobile Application Development

The autonomous outdoor garbage bin system requires a mobile app so that the user is notified when the trashcan is full. The main purpose of creating a mobile app is that the user can keep track of the outdoor garbage bin remotely. It is really important to choose the best and suitable platform for the development of the mobile application for the autonomous outdoor garbage bin. In this section, the platform used for the development of the mobile application will be discussed. The use case diagram- which is a graphic representation of the user's interaction with the system- is displayed below in Figure 49.

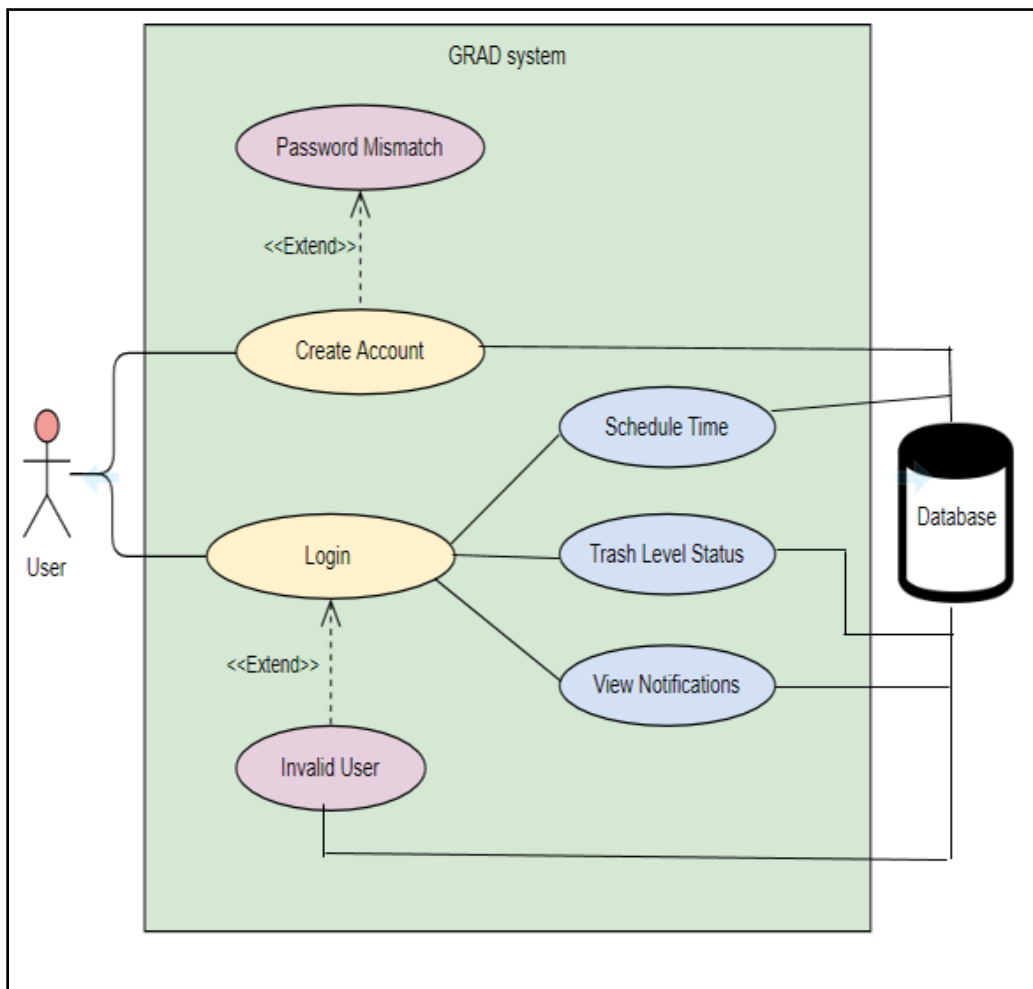


Figure 49: Use Case Diagram for Mobile App

In order for the mobile application to be completely functional as per the requirements, the mobile app will need to have the ability to connect and retrieve information from the microcontroller that will be attached to the outdoor garbage bin. The mobile application will have the capability to navigate itself to the curb according to the time that will be set by the user. Initially, the intention is to utilize Mongo Atlas as the database storage service. The database is required for the mobile application so that the application can have access to all information stored in the database. In this case, the information stored would be the user's login information. Moreover, the mobile application should also have the ability to add the schedule time information to the database. It will be very crucial for the software of the mobile application to work consistently with the database.

Apart from running the application, the software of the application must be designed in order to collaborate and work with the user's phone notification system. This notification system is simply to notify the user when the level of trash in the outdoor garbage bin is full. In other words, the application will simply relay the notification when the level of trash reaches the max limit that will be defined in the code.

### **3.5.2 Integrated Development Environment Platform for Application**

#### **Android Studio**

Android Studio IDE is an officially supported Google developing Android app. This IDE offers a variety of developer tools and a strong coding editor. It supports programming languages such as C++, Java, Go (with extension) and Kotlin. The IDE has a built-in debugger. Android Studio has a fast emulator that allows the user to see how the application will look like in actual physical devices such as phones, tablets, and Android TV devices. The Android Studio has an intelligent code editor that allows the user to write better code and it also offers advanced code completion. The Android Studio gives suggestions as the user is typing the code. The Android Studio uses Gradle based builds that provide the flexibility to generate APKs for all device types [66]. Android Studio uses Gradle through a plug-in.

Android Studio is designed for teams so that they can collaborate easily. It integrates with GitHub and Subversion so that the teams can sync with the project and build changes as they code [66]. This is a very great feature in Android studio as it allows to share code and makes sure that no code is overwritten by other changes. This is the major reason why Android studio is very popular in mobile application development. Android studio might be slow while developing mobile app, but it also has some benefits.

As mentioned earlier, Android Studio is well-liked integrated development environment (IDE) used for mobile application development only for Android devices which means that this application is only supported for Android devices. This is a major drawback of Android Studio. On the other hand, Android studio is used by a vast number of software developers because it allows the developers to develop a mobile application easily with tons of libraries and templates provided. In addition, the users have a developer-friendly environment which is very useful even if the user is a beginner. The programming languages supported by the Android studio provide the software developer with options.

Android Studio like other tools that will be discussed in the next sections has its advantages and disadvantages but is an excellent mobile application development tool that is used in the industry.

## **Flutter**

Flutter is Google's other mobile application software development UI toolkit. It is widely utilized for creating or building amazing, natively compiled for both Android applications and iOS applications from a single codebase. Flutter is open-source and allows the development of applications for web and desktops as well. The main feature of Flutter is that it gives the ability for software developers to build mobile/ web applications that can run on different platforms [67]. This way the software developers do not need to develop Android and iOS apps separately.

The software developers utilize Dart programming language when developing an application using Flutter. Dart is an object-oriented programming language similar to other programming languages like Java and JavaScript. Just like Flutter, Dart programming language was also introduced by Google and because it is a new programming language it is rarely used by software developers [68]. However, software developers who are familiar with JavaScript and Java programming languages for mobile application development easily catch up with Dart. Dart is an effective and modern programming language that provides high performance for the app. The three main features of Flutter are that it provides fast development, it has an expressive and flexible UI and has native performance [67]. Flutter has a hot reload feature that allows the software developers to easily and quickly build UIs, fix bugs and add features. Flutter is richer in components. In other words, the Flutter framework is bundled with UI rendering components, device API access, navigation, a vast number of libraries, stateful management, and testing [68]. In other words, the Flutter framework is bundled with UI rendering components, device API access, navigation, a vast number of libraries, stateful management, and testing [68]. The main advantage of the Flutter framework is that it will provide everything that is required for software developers to develop mobile apps.

As stated in the previous paragraph, Flutter is a cross-platform that allows the mobile development for both iOS and Android from a single codebase. In addition, Flutter has widgets for Cupertino and Material Design that allows software developers to easily render the UI on both Android and iOS platform [68]. Even though Flutter is new to beginners and some of the software developers, the community is still growing rapidly. Flutter also helps to reduce the code development time and this feature is crucial for software developers who are developing mobile apps. One another great benefit of Flutter is that it allows the software developer to do a lot of stuff while developing their app that is not available on other platforms. There are several advantages of using Flutter.

Flutter provides a fast code development by the "hot reload" feature. Flutter is for business purposes that have short deadlines because it helps the software developers to code quickly and easily that helps them to develop mobile applications in a short amount of time provided. This means that Flutter is also good for this project because of the short deadline. Furthermore, during the development of the application in case, if the application crashes at any point, the software developers have the ability to fix the crash at that point and



continue to debug from right after the application was left off. These features and abilities of Flutter allow it to be the best match for the cross-platform mobile development.

## **Ionic**

Ionic is an open-source software development UI toolkit that is aimed to develop hybrid mobile apps. The Ionic framework allows the software developers to build applications on cross-platform such as desktops, Web, native iOS, Android through all one code base that means the developer can write the code once and run anywhere. Ionic supports standardized web development languages including CSS, HTML5, and JavaScript by utilizing modern Web APIs such as Custom Elements and Shadow DOM [69]. Ionic allows software developers to create web pages that can run and function on a device that is simply called WebView. The main purpose of Ionic is simplicity that allows developers to create apps that is easy to learn, enjoyable and easily accessible to those with some web development skills.

Ionic is a good choice for developing an application with basic native functionalities within it so that the application can run on various devices. According to the web technologies Ionic uses, Ionic focuses on the front-end UI framework that handles the UI interactions of the mobile app that is being developed so that the app looks amazing. Ionic utilizes Ionic Native like PhoneGap or Cordova or Trigger.io so that it can run as a native app [70]. This can be simply done by referencing the Ionic JS and CSS files from the web root of the mobile app and adding the Ionic to Trigger.io, PhoneGap, or Cordova project. Ionic comes with optional JS framework extensions and Sass files. Moreover, a compiled CSS and JavaScript for the app are included. Ionic has node.js utility that is utilized to start a quick Ionic project [71]. Currently, Ionic requires AngularJS so that it can work at its full potential. There is an option for the software developers to utilize the CSS part of the framework. However, using CSS will not provide powerful and amazing animations, UI interactions, and other things that Ionic can provide initially [71].

There are currently two different available versions of Ionic for mobile app development. The first version is Ionic 1 provides tools that are mainly focused on creating a hybrid or native mobile application rather than mobile websites. On the other hand, the second version of Ionic, Ionic 2 provides the tools that help to build a hybrid or native application through Cordova additionally adding the ability for Electron and progressive Web Apps [71]. Ionic 1 supports UIWebView for the older version for iOS and Android. For improved performance on the older versions using Crosswalk is recommended. Ionic 2 supports a newer version for iOS, Windows 10 and Android.

As priorly stated, the benefit of using the Ionic framework is that it allows software developers to build mobile applications across various platforms through a single codebase. The testing process is very convenient in Ionic because of the built-in testing and debugging tools the browser offers. There are several advantages of using the Ionic framework because it allows cross-platform app development, open and free source, user-friendly UI and the use of AngularJS provides powerful, rich and robust mobile applications. On the other hand, software developers need specific skills and knowledge when developing an application on the Ionic framework as it can be more difficult than Flutter.

## ReactNative

ReactNative is another great framework that allows software developers to develop exciting and real mobile applications using JavaScript. ReactNative was originally developed by Facebook in 2015. ReactNative framework is the most popular and widely used cross-platform mobile application development that supports both iOS and Android platforms [72]. Both JavaScript and React is allowed while using ReactNative for the development of the mobile application. Reacts' JSX syntax is utilized by the software developers for developing the mobile app's UI. The code is compiled into JavaScript while runtime [72]. Similar to Flutter and Android Studio, ReactNative is also an open-source framework. Facebook, Instagram, Tesla, etc are the most popular and commonly used mobile applications used in day to day life and are developed using ReactNative.

ReactNative is a great choice for those software developers who have experience and knowledge about the language JavaScript. One benefit of using ReactNative is focused more on UI that makes the mobile applications load quickly and give a nice smooth look. As stated before, the main advantage of using ReactNative is that it utilizes cross-platform that help to develop mobile apps using a single codebase for both Android and iOS platform simultaneously that increased that popularity of ReactNative more in the software industry. The benefits of using ReactNative include ease of maintenance, ability to reuse components and faster development of mobile applications [73]. Many software developers mostly prefer to use ReactNative to develop mobile applications because it is easy with high efficiency and lower cost while developing the applications. Moreover, it gives the software developers the confidence to work with robust tools while developing mobile applications. The intelligent debugging and error reporting tools are an advantage of using ReactNative. React Native like Flutter also has a "Hot Reload" feature. Hot reloading feature allows the software developers to load libraries into the mobile application when executing without affecting the application. React Native can be coded in any text editor that act as IDE. The most commonly used IDE to develop applications using ReactNative are Atom, Visual Studio Code and Sublime.

Despite having many advantages there are also some drawbacks of using React Native. It depends on the developers and the team whether React Native is a good choice for mobile application development. As compared to Flutter, React Native's architecture is poor [72]. React Native uses JavaScript bridge in order to communicate with the native modules which degrade the performance of React Native as compared to Flutter. React Native can be quite complicated and complex for beginners that do not have experience with JavaScript or web development. Some of the custom modules are underdeveloped in React Native.

The community support for React Native is strong as compared to Flutter and Ionic. A lot of companies in the software industry rely on the React Native framework to develop and create real and exciting mobile applications that allow people to use it in their everyday life. Learning about how to use ReactNative will really help the team to learn new skills as ReactNative is very trending in the industry. Moreover, mobile apps created using ReactNative are very responsive and faster by providing the user with impressive experience. ReactNative are really beneficial of Hybrid apps and cheaper compared to the Native apps.

## NativeScript

NativeScript is another JavaScript based framework like React Native that is used for developing native cross-platform mobile applications. NativeScript is an open-source framework. NativeScript uses Angular or Vue to share existing web-based code [74]. NativeScript utilizes cross-platform that help to develop native mobile apps using a single codebase for both Android and iOS platform. All native platform APIs can be accessed directly on both iOS and Android from TypeScript, JavaScript or Angular. NativeScript provides a truly native experience because it utilizes the native platform's rendering engine. The performance is dependent on the platform because the program is natively rendered. Some apps developed using NativeScript are Dwitch, Daily Nanny, Strudel, BitPoits Wallet and Rengelneef [75].

The drawback of using NativeScript is that it has a pure native nature that means that the developer can only test the app on an emulator or an actual device. Moreover, some UI components are not available for free and need to be purchased if the developer requires it.

Category	React Native	Flutter	Android Studio	Ionic
Language	React & JavaScript	Dart	C++ & Java	HTML, CSS, JavaScript
Nature of apps	Cross-platform	Cross-platform	Native app	Hybrid cross-platform
Developer	Facebook & Community	Google & Community	Google & Community	Drifty Co.
Community Support	Strong	Not very popular	Strong	Strong
Supported Platform	Android, UWP, iOS	Android, Google Fuchsia, iOS	Android	Android, iOS & Web

*Table 19: Mobile Framework/ IDE Comparison*

After analyzing the different types of mobile frameworks/ IDEs, the team decided to choose Android Studio as an IDE to develop a mobile app for the outdoor garbage bin. The team is familiar with Java and C++ programming language, which makes it easier to code in Android Studio. While developing the app, we can test it easily on the emulator even if we do not have the actual Android device.

### **3.5.3 Stacks**

Stacks are basically some related technologies that are/can be used to create applications. There are two sides to web development: the client-side and the server-side. The client-side is the front end which can be seen by the user. The server side is the back end which involves some programming, database, and server. The stack consists of an operating system for the server, software to manage web server and the database, and a programming language for the user using the website.

A lot of things have to be taken into account while choosing a stack in order to develop a perfect web application. There are some popular stacks that software developers utilize such as LAMP, MEAN, WISA and MERN. Each stack will be discussed in brief to have a better idea of stacks.

#### **LAMP stack**

The most popular stack is the LAMP stack. A LAMP stack is a bundle of an open software tool that can be used to create web applications or websites. LAMP stack consists of Linux operating system, Apache HTTP web server, MySQL database management system and the PHP programming language. The advantage of LAMP stack is that it is completely open-source and easier to customize whenever you feel to. Nowadays people often use Linux, as it is the best operating system for web developers. However, LAMP is an older stack and is not best at performance and has compatibility issues. Also, LAMP is difficult to learn as it requires knowing everything about Linux and Apache server, and a few other languages.

LAMP stack is a great platform of choice for the development of high-performance web applications that require a reliable base. LAMP stack is a good choice for business because of the benefits it offers. LAMP stack is beneficial in many ways such as more secure, easy to develop, more community support, great flexibility, and customization. Moreover, if the developer uses the LAMP stack there will be only a few lines of code to write and helps to debug easily. The drawback is using LAMP stack is that it is not as efficient as MEAN and MERN stack. In the future, MERN and MEAN stack will be adopted more as LAMP might get outdated.

#### **WISA stack**

WISA stack consists of Windows operating system, International Information System web server, SQL database management system, and Active Server Pages.NET programming language. The benefit of this stack is that all of the pieces come from the same provider: Microsoft and they have the advantage of being designed to work together and the installation of the software is easy. The main purpose of the WISA stack is the IIS server that runs the webserver within windows. The developer can design web pages in a browser that runs on a local IIS web server. The reason why designers prefer WISA stack is that it helps them in faster development. WISA stack is more commonly used in enterprise-level systems looking for features such as security, business intelligence, etc. However, this means that one needs to have licenses to use the software for business and is expensive.

## **MEAN stack**

MEAN stack consists of MongoDB database that is used by back-end applications to store its data as JavaScript Object Notation documents, ExpressJS that is basically a framework used to build web applications in Node, AngularJS is a JavaScript framework scripting language and Node.js is server-side JavaScript execution environment. The benefit of MEAN stack is that it supports programs that are written in one language that is JavaScript. Using the same language for both sides of development makes it easy for front-end and back-end developers to communicate and understand each other's work and eliminates the need to learn additional programming languages. MEAN stack is growing in popularity and is valued for its flexibility, scalability and consistent language (JavaScript) that allows it to be fast and easy to scale. However, MEAN doesn't have a large community which means it provides less support than LAMP or WISA stack. There are possibilities of having faults. Also, it has poor isolation of server from business logic.

There are several benefits of using a MEAN stack. The architecture of MEAN stack is simple and basic to utilize for both front and back end technologies. The applications using MEAN stack are easier to develop. The amazing feature of MEAN stack is that it allows the software developers to write the code in one language that is JavaScript. Software developers that have expertise in JavaScript language make it easier for them to use the MEAN stack. It also has a vast number of module libraries for Node.js that help the developers to save their time as they don't have to create any module from scratch. Most of the popular mobile application development companies utilize the MEAN stack for creating mobile applications. As priorly stated, the data is stored as JSON format that does not require reformatting.

## **MERN stack**

MERN stack consists of a MongoDB, ExpressJS, React and Node.js. MongoDB is a non-SQL database that is used by the back-end application to store data as JSON objects. ExpressJS is a back-end framework for Node.js. React is a front-end JavaScript framework that is utilized for building UI. Node.js is a cross-platform Javascript runtime environment. The MEAN stack is very similar to the MERN stack. The only difference is that the MERN stack utilizes React to build the front-end whereas MEAN stack uses Angular. Nowadays, most of the software developers prefer to React over Angular. Node.js is highly scalable and provides a fast code execution feature.

The MERN stack is a great choice because of React that has the ability to develop mobile applications. The technologies utilized for the MERN stack are open-source and free. A huge community of software developers supports the MEAN stack. The entire development cycle of an application is covered using the MERN stack i.e. starting from back-end to front-end development. MERN stack has better performance than MEAN stack because ReactJs helps develop the code faster than Angular. For the faster development of small applications, the MERN stack is a great choice. Moreover, the MERN stack is cost-effective.

Category	LAMP Stack	MERN Stack
Operating System	Linux OS only	Cross-platform
Technologies involved	Linux, Apache, MySQL, PHP/Python/Ruby	MongoDB, Express.js, React, Node.js
Database	MySQL, a 'Relational Database	MongoDB, a 'Non-Relational Database
User Development	Multiple layers with different syntax and files for front end development	JavaScript is utilized for both front-end and the back-end development
Scalability	Low	High
Cost	High, as it requires specialists for both front-end and back-end	Low, as only JavaScript specialist is required

*Table 20: Stacks Comparison*

After analyzing each stack, mainly LAMP and MERN stacks, the team decided to use the MERN stack *if* the application will be implemented on web. A web application is a backup plan if the mobile application proves unsuccessful.

### **3.6 Part Selection Summary**

The overall system is comprised of many components that ensure the proper functionality and reliability of the GRAD system. The previous sections outlay the comparison of each component of the GRAD system from the hardware, including power supply, motors, sensors, and microcontrollers, to software, including different programming and implementation techniques for the GRAD operation and the connected app. This section summarizes the previous sections and explicitly states which components were chosen. The overall component status and summary are broken down by subsystem: Table 21: The Microcontroller, Table 22: The Power Supply, Table 23: Sensor Selection, Table 24: The Drive Selection.

Microcontroller and Modules Selection		
<b>Microcontroller</b>	Arduino Mega 2560	Received
<b>Real Time Clock Module</b>	DS3231	Received
<b>Wi-Fi Module</b>	ESP8266	Received

Table 21: Microcontroller and Modules Selection

Power Supply Selection		
<b>Power Source</b>	Renogy 12V 30W Monocrystalline Panel	Received
	Weize 12V 20AH Lead Acid Battery	Received
<b>PCB</b>	Eagle Free Software	N/A
	OSH Park PCB Manufacturer/Assembler	SD2
<b>Voltage Regulation</b>	LM317 (Solar to Battery)	Received
	LP2985 (5v to 3.3V for Components)	N/A
	L298N (Motor use and Voltage Regulation)	N/A

Table 22: Power Supply Selection

Sensor Selection	
<b>Ultrasonic Sensor</b>	HC - SR04 5V 15mA sensor
<b>IR Sensor</b>	OSOYOO IR Infrared Obstacle Avoidance Sensor Module

Table 23: Sensor Selection

Drive System Selection		
<b>12V DC Gear Motor</b>	Servo City-Econ Spur Gear Motor	In Transit (being shipped)
<b>Garbage Bin</b>	Toter 32G Two Wheeled Trash Can	N/A
<b>Swivel Wheel</b>	Everbilt Thermoplastic Rubber Swivel Wheel	In Transit (being shipped)

Table 24: Drive System Selection

## **4.0 Applicable Standards & Realistic Design Constraints**

Standards play a key role in the development of any type of product. From research to actual realization, implementation, and use of the product in the marketplace is affected in one way or the other by standards regulated nationally and internationally. It is very important for our group to abide by standards applicable to the technologies used in our research and development to bring product success to the marketplace. By utilizing standards, we hope to enhance our group project with the best engineering methods but also be part of a newly developed concept of our product not found in the market and settings standards to be developed.

Our group will utilize various standards such as the Institute of Electrical and Electronics Engineers (IEEE), The American National Standards Institute (ANSI) and The National Resource for Global Standards (NSSN). With the use of these highly regarded institution standards, we hope to gain guidance and applicable resources in the research and development of our project.

While following the standards, we will also be mindful of the impact by the constraints put by the standard institutions on the design and development. Overall, our project's goal for GRAD system is to eliminate the physical stress and time demand while also considering for the health, safety, social and economic reasons.

### **4.1 Applicable Standards & Design Impact**

#### **4.1.1 IEEE Wireless Standards**

The Institute of Electrical and Electronics Engineers (IEEE), is an association that regulates and mandates numerous standards in engineering projects. One of important standards set into place is standard 802.11. This standard is extremely important to this project because the user will communicate with the GRAD system wirelessly using an application on the phone. In the market, products that implement this standard must pass tests in order to be considered "Wi-Fi certified." The common Wifi used is of the 2.4 GHz wireless spectrum and this will be sufficient for our project.

#### **4.1.2 Wi-Fi Standards**

IEEE 802.11 specifies a set of guidelines for implementing Wi-Fi, and it is a subset of the IEEE 802 set of LAN (local area network) protocols. IEEE 802.11 details MAC (media access control) and PHY (physical layer) protocols used for implementing WLAN (wireless local area network) communication. These standards apply to Wi-Fi across multiple frequencies, including the 2.4GHz and 5GHz frequency bands. The development of the first IEEE 802.11 standard occurred in the year 1997, and the standards have been built upon and expanded through the addition of new standards and modification of old ones. An outline summarizing the specifications of IEEE 802.11 family is outlined below [76]:



- **802.11**- This standard applies to wireless LANs, and it gives 1-2 Mbps transmission using either FHSS (frequency hopping spread spectrum) or DSSS (direct sequence spread spectrum) in the 2.4 GHz band.
- **802.11a**- Extends the 802.11 standard by providing up to 54 Mbps in the 5 GHz frequency band. Rather than using FHSS or DSSS, it utilizes an orthogonal frequency division multiplexing encoding scheme.
- **802.11b (also known as Wi-Fi or 802.11 High Rate)**- Another extension of 802.11 that applies to wireless LANs. Using only DSSS, it provides 11 Mbps transmission in the 2.4 GHz band. This standard enabled wireless functionality similar to Ethernet.
- **802.11e**- This standard outlines the Quality of Service (QoS) support for LANs. It also adds multimedia support to the older 802.11a and 802.11b wireless LAN specifications while maintaining full backwards compatibility.
- **802.11g**- This standard applies to wireless LANs and provides a maximum transmission rate of 54-Mbps over short distances in the 2.4 GHz band.
- **802.11n**- This standard added multiple-input-multiple-output, or MIMO, thus allowing for a higher data throughput due to additional transmitter and receiver antennas that allow spatial multiplexing. Compared to 802.11g, 802.11n is 4 to 5 times faster, and it also has a larger range.
- **802.11ac**- Building upon the previous 802.11 standards, the 802.11 standard provides data rates of 1.3 Gbps in a three-antenna design (three stream) or 433 Mbps per spatial stream. This standard only applies to the 5 GHz frequency range, and it provides to wider channels such as the 80MHz and 180MHz channels.
- **802.11ac Wave 2**- An update to the 802.11ac standard, the 802.11ac Wave 2 standard uses MU-MIMO technology to increase maximum wireless speeds to up to 6.93 Gbps.
- **802.11ad**- With a theoretical maximum data transfer rate of 7 Gbps, this standard in development will operate in the 60 GHz band and provide much higher data transfer rates than its predecessors.
- **802.11ah (also known as Wi-Fi HaLow)**- This is the first Wi-Fi standard to operate in frequency bands below 1 GHz. The range it provides is nearly double that of other Wi-Fi technologies, and it is also able to better penetrate physical barriers such as walls.
- **802.11r (also known as Fast BSS Transition)**- An addition to the 802.11 standard that supports Vo Wi-Fi. It allows for fast and secure roaming on a Wi-Fi network using 802.1X authentication.
- **802.1X**- This standard applies to port-based Network Access Control. It provides extra security for communication between authenticated and authorized devices by allowing network administrators to restrict the use of IEEE 802 LAN service access points.

The standards that apply the most to GRAD are the 802.11a, 802.11b, and 802.11g standards since they apply to home users. Implementing these Wi-Fi standards into the GRAD system will ensure proper functionality and connectivity of the communication systems within. This ensures the system will run when desired and provide an execution of the required deliverable as previously laid out in the engineering requirements section.

### 4.1.3 Printed Circuit Board Standards

Printed circuit boards are used in many electronic systems today. The Institute for Printed Circuit (IPC) is a trade association that was developed in 1957. They create standards that assist the assembly and creation of electrical devices. The IPC has four main goals which are standards, education, advocacy, and solutions. Due to their efforts, there has been a set of standards for the printed circuit board as well as other electrical components that have been created. These standards assist in the components that are created for PCBs, the software that companies create for the design of PCBs, to even how the manufactures assemble and develop the created printed circuit board. Following these set of standards can ensure proper functionality of the circuit board, as well as increase longevity of the devices. Certain standards such as the IPC 2221 which is the Generic Printed board standard from the IPC, which covers all aspects of a general PCB including the materials, physical components, thermal requirements, quality and more. Other standards such as the IPC-A-600 or IPC 6012 can be considered in the acceptability and qualifications, respectively, of the circuit board [77]. In Figure 50, on the second to next page, which is provided by the IPC, displays all the standards and qualifications that have been established from start to end when designing a product. For this current project these standards will not necessarily relate directly to the design group, as the software and the board manufacturers that will be used to complete the PCB will abide by these standards [78].

The IPC defines electronics into three classes. The first Class is defined as General Electronic Products, which includes many electronics that many people use day to day. This class is electronics that the main function and operation of the system comes fully assembled. Class II electrical systems are defined by the IPC as dedicated service electrical products. This class of products prefers no interruption to the service; however, this specification is not a requirement. These systems also should have an extended lifetime and increased reliability. Lastly, Class III products are labeled by the IPC as electrical products are high performance. These systems are expected to consistently and continuously run without interruption. These devices are required operate upon demand, such as a life support system. Class III devices require full reliability and stable functionality, however there is no stated lifetime expectancy [79].

These classifications allow system to follow a set standard and help in the design process of the PCB. Applying an electronic class helps a user, designer, or manufacturer in understanding the overall functionality of the device. Applying these standard classifications to the GRAD system, Class I would apply as this device does not require continued service or uninterrupted service. Since the GRAD system will only be operating to take the trash from the curb and back to the house, interrupted service is allowable in the sense of overall safety. Interruption of the service of the GRAD does not harm a user or the environment around. While, interrupted service can be inconvenient to the user or to the environment at hand, the GRAD system will also be moveable without the full functionality of the system. This ensures that the GRAD system can be moved if in the endangering of the environment or user. However, the system itself, falls into Class I as uninterrupted service is not required and the GRAD system can be moved without operation of the system by the user.

Before analyzing the defined standards for the Printed Circuit Board, as displayed in Figure 50, a few definitions that apply to the standards are required to fully standardize a system. It is essential that both the user and the developer, as well as a mechanic to understand these definitions to comprehend the testing and acceptance levels of the designed system. If there are issues with the system understanding the standards and tests that were implemented could assist the user in creating a process and technique for problem solving. These definitions are outlined below:

- **Acceptance Tests** are agreed upon test by the purchaser and manufacturer that determine the adequacy of a device (in this case a PCB).
- **Assembly** is the joining of all the components and various parts together (to create a PCB).
- **Resist** is a material that is implemented to protect a device or system from the testing and manufacturing aspects of the design and assembly period, such as soldering.
- **Integrated Circuits** are those that are comprised of smaller inseparable circuit elements which overall combined achieve a desired function. They are connected using some base.
- **Flexural Strength** is how flexible and the strength of the exterior layer of a bendy material.
- **Critical Operation** is the most critical function of the entire system of circuit which can have influence on the characteristics of the system (for the GRAD PCB this would be power flow and regulation).

All these definitions and standardization categorizations can be applied to the GRAD system for individual parts including the PCB [79]. Implementing these standards and providing these definitions provide the user with the tools to understand the safety and design of the system to better equip them during usage of the product. Since the PCB will be assembled and manufactured from OSH Park and designed in Eagle Free from AutoDesk, the software program and the PCB manufacturer and assembler will implement and abide by these above standards to ensure proper functionality of the system. Each component of the PCB follows the standards that the company who manufactures and distributes the system abides by.



## IPC STANDARDS — EVERYTHING YOU NEED FROM START TO FINISH

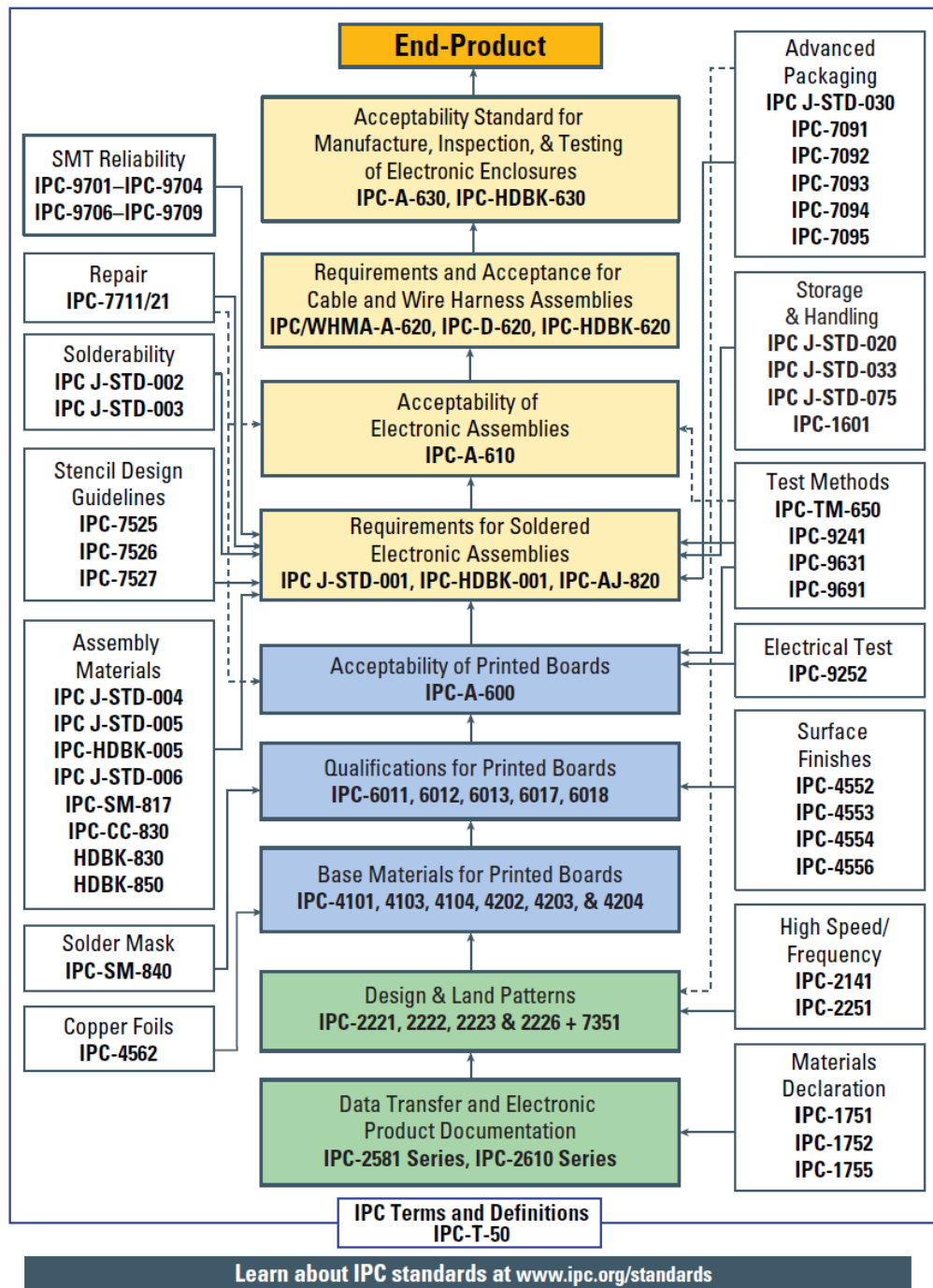


Figure 50: Printed Circuit Board Standards from IPC

#### **4.1.4 Electrical Shock Standards**

IEC 61140 is an international standard for protection against electrical shock. The International Electrotechnical Commission (IEC) is an international standards organization that implements standards for electrical and electronic technologies. The IEC 61140 standard is implemented to protect humans and animals from the electrical shock of systems and applications. Installation, equipment, coordination is covered in this standard as well as ensuring proper functionality and protection of the system [80].

The classification of power sources is outlined in the power supply section. However, to comply with standards and to ensure the safety of the users and any obstacle that may encounter the GRAD system. Class I power supply will be implemented. Upon this classification, the GRAD system is run on voltage not exceeding 20V. This allows the system to not be labeled as a hazardous voltage.

#### **4.1.5 Battery Standards**

The battery used in the systems is a Lead Acid that is 12V, which requires certain procedures and steps for proper functionality. American National Standard Institute (ANSI) is a non-profit organization that focuses on standardizing processes, systems, and components for the United States. ANSI C18.2M: Portable Rechargeable Cell and Batteries is an ANSI standard relating to rechargeable batteries, in this project the rechargeable Lead Acid battery. There are two parts of the standard, which are both developed by ANSI and the National Electrical Manufacturers Association (NEMA).

The first part of the standard is the general specification as well as the types of batteries. The second part of the standard is related to the safety and guidelines behind portable lithium and nickel batteries. This standard includes hazard avoidance as well as specifications for testing in terms of altitude, shock, overcharge, physical and chemical usage. This ensures proper functionality and reliability of the system to increase the safety of the device. Implementing these standards into the battery subsystem allows proper functionality and safety of the overall system due to the Lead Acid battery being placed within the GRAD system [81].

The battery is essential to the operation of the system to ensure that the motors and the rest of the system have enough load at the time of operation. If the system is to operate later in the day, the solar panel will be tasked with charging the battery to which the battery is the main source of power if the load is greater than what the solar panel produces at a given time [81].

For proper functionality of the battery, the use of voltage regulators and Schottky diodes are implemented into the system to ensure the battery does not experience either over or under voltage as well as overcharging [81].

#### **4.1.6 Photovoltaic Battery Standards**

IEEE 1562 Guide for Array and Battery Sizing in Stand-Alone Photovoltaic Systems is a standard by IEEE in aims to provide users with proper sizing and installation of stand-alone PV systems as well as the batteries that accompany them. A stand-alone photovoltaic

system is a PV system that is not connected to the electrical grid. The standards for battery sizing, as well as solar array standards, are different from stand-alone compared to when they are connected to the electrical grid due to various other standards and requirements needed to ensure reliability of the electrical grid. Since the system is not connected to the grid it must rely solely on the solar panel as well as any other generation or storage that the system contains. This requires a specific set of standards that ensure its reliability, functionality and safety. This standard, IEEE 1562, covers details to ensure the battery has adequate controls to ensure that it is not under or over charged as well ensuring efficiency and performance of the system due to type and size of both the battery and the solar panel.

IEEE 937 and IEEE 1013 are standards that ensure proper functionality of Lead-Acid batteries along with photovoltaic systems. IEEE 937 standard covers proper practices for the installation and maintenance of the batteries associated with the photovoltaic systems, whereas IEEE 1013 discusses the proper requirements in sizing of the lead acid battery for a photovoltaic. Both do not include various analysis of the weather associated with the system. They both however provide assembly, ventilation, sizing and maintenance recommendations for the battery and the panel.

IEEE 1013 and 937 as well as the other standards associated with this do not consider other battery types. However, this project implements a Lead Acid battery rather than these other types due to our project monetary constraints. The standards can be used as a guideline in the design, construction and maintenance of the GRAD system [82].

These standards outlaid above provide as a resource for connecting batteries to solar panels but do not provide depth analysis to individual commonalities or variances. The weather, climate or other locational aspects of a system that could have an affect upon the battery and the efficiency of the overall product is not implemented or considered. These standards also do not provide a depth analysis in the comparison between batteries and the functionality of them in terms of the solar panels. These standards provide knowledge and suggested rules and guidelines that should be followed when implementing a desired product as described through the standards. This could include guidelines for a specific battery as each battery will require different components and installations guidelines for efficient use. These standards do not describe the maintenance of the system, however continual maintenance and checks of the batteries aligned with the system should take place.

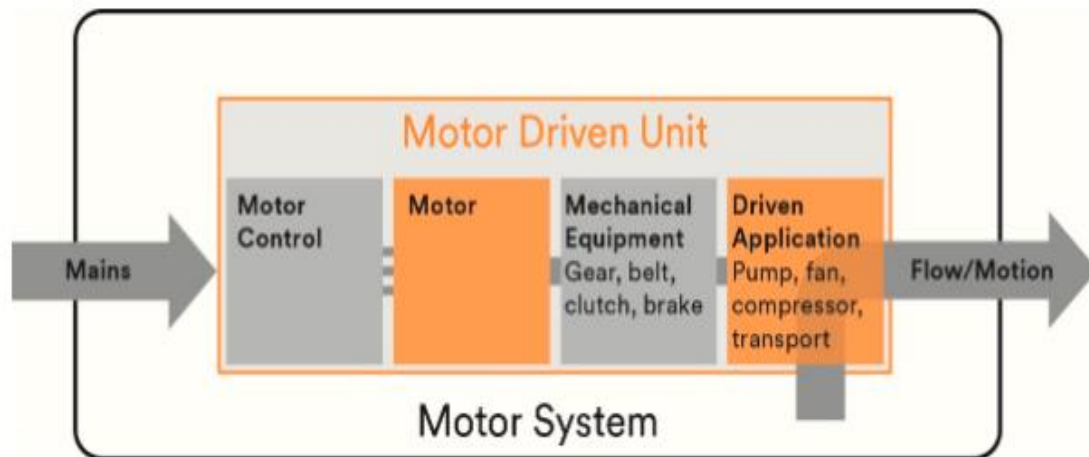
These standards also provide an analysis to Stand-Alone photovoltaic systems. At no point should the user connect the solar panel or the battery to the electrical grid as this could result in physical harm or even death. Different standards and design implementation must be considering in connecting the GRAD system or individual components to an electrical grid. At no point should the GRAD system solar panel be used or connected to the house hold as the system operates at a different voltage than the common household. These standards do not provide the information for this.

Combining these standards into a system would ensure accurate, reliable and safe practices of the system. This would minimize the harm of the user, bystanders and the physical device itself.

## 4.1.7 Motor Standards

With varying sizes of motors and uses, the International Electrotechnical Commission (IEC) has standardized practices of testing and certifying electric motors on energy efficiency and created standards on basic characteristics and motor performance. The IEC works with many governments to harmonize their national standards with the international standards and classifies with four levels of motor efficiency in IE-code 60034-30-1. Currently, United States with many other first-world countries meets the premium efficiency class code IE3.

This shows that motorized products produced within United States and the ones imported are regulated by classification standards. It is crucial for the success of our GRAD system to integrate the best quality and high energy efficient parts to meet global demands. The IEC goal of standardizing a one test method to classify motors has led to an understanding of a motor system consisting of different subcomponents such as the motor control, motor, mechanical gears, and uses of the motor unit as shown in Figure 51 below:



*Figure 51: Classification of Motor System from IEC [85]*

We ensured to follow standard guidelines when ordering the motors for our drive system. While the motors come with built-in mechanical gear, and other components, we are purchasing a separate motor controller to control the current, speed, and torque of the motor. The motors that we purchase come from a vendor known as a ServoCity within the United States who sell products from manufacturers such as Hitec and Futaba which are also US-based. The manufacturers follow the national standards which in return also comply with the IEC ensuring standard requirements are met in terms of labeling of the motors including the specifications such as operation modes in high temperature, voltage, current, frequency, speed, torque, etc.

While the motor manufacturers ensure standards are met, we are also taking notice while testing of IEC basic characteristic standards [83] such as enclosure protection (IEC 60034-5), motor mounting (IEC 60034-7), motor noise (IEC 60034-9), and explosive atmospheres (IEC 60079-0) to ensure the safety and operation of motors in our system.

## 4.1.8 Power Supply Standards

A power supply is essential to the operation of the system and implementing standards across the complete power source ensures proper functionality and reliability, as well as increased safety. The purpose of power supply standards is to ensure that the users and the electrical equipment involved are protected from any type of hazard such as fire, electrical shock, chemical exposure, or injury. The main agencies that oversee that electrical safety standards are The International Electrotechnical Commission (IEC) as well as the International Organization for Standardization (ISO). While there are more agencies and companies which oversee electrical standards, these are the primary agencies. These agencies have partnered with CUI INC to establish a list of mark and qualifications as well as definitions that apply to the safety of electrical power supply products.

There are three types of classes that electrical power sources can be categorized into. Class I is the category to which electrical equipment and all conductive parts are protected through insulation and connected to the Earth's true ground. This labels all conductive parts of this piece of equipment as hazardous voltage. The second class enables double and/or reinforced insulation, which allows no ground to the Earth to be required. Lastly, Class III systems operate at a very low voltage level, which can be described as SELV (Safety Extra Low Voltage). This type of equipment within this class has voltage low enough that it would protect itself again electrical shock, meaning it does not fall within the hazardous voltage categorization.

Classification of the voltage level of the system is essential and beneficial when producing a design from the designers, manufacturers, technicians, and users of the products. Labeling certain voltage levels into classes allows the user that is coming in contact with the system knowledge of the power systems.

Designing and producing a product, such as the GRAD system, requires standards to be implemented and it also requires defining certain aspects of the system. Table 25 and Table 26 defines standardized terms that apply to power sources, which allow the user to know about the system and the safety of it. Table 25 defines the voltage definitions that apply to this circuitry, whereas Table 26 focuses on the limiting factors of circuitry to ensure safety [84].

After labeling the voltage classes into different levels and labeling them, this provides the user and anyone who operates maintenance upon the system knowledge in terms of proper safety. Applying the classification of voltages into the GRAD system, the GRAD system will operate on voltages that are under that of  $60V_{DC}$ . This means the system will be operating on levels that are considered non-hazardous. Non-Hazardous voltages can still be a threat to any user and all electrical components should be approached with caution. However, since the voltage of the system does not exceed the voltage labeled as Hazardous, the GRAD system level could cause harm, but it is unlikely to cause harm and/or death. Certain measures will still be taken to ensure that the battery and solar panel components will be protected for the user in mind. The battery will be compartmentalized to ensure that the user does not interact with it on a day to day basis.



<b>Power Supply Standards (Voltage)</b>	<b>Definition</b>
Hazardous Voltage	Applies to a voltage that exceeds 42.2 V <sub>ac</sub> peak of 60 V <sub>dc</sub> . This voltage must apply to the circuit and the circuit must not be a limited current circuit.
Extra-Low Voltage	Extra-Low Voltage (ELV) applied to secondary circuit that as a voltage that does not exceed the hazardous voltage (ELV circuits do not exceed 42.4 V <sub>AC</sub> peak of 60 V <sub>DC</sub> ). The circuit that this definition applies to must obtain some basic insulation to which the circuit is separated from some hazardous voltage.
Safety Extra-Low Voltage Circuit	<p>Safety Extra-Low Voltage Circuit (SELV) is similar to Extra-Low Voltage however contains more requirements. This type of circuit is one that cannot obtain a hazardous voltage between two parts/components or a part/component and the true ground (earth) under its standard operations conditions. The circuit may also experience a fault and these conditions must still apply. During this fault each component must be under the hazardous voltage as defined in the Extra-Low Voltage above (42.4 V<sub>ac</sub> peak of 60 V<sub>dc</sub>) for less than 200ms or a total of 71 V<sub>AC</sub> peak of 120 V<sub>DC</sub>.</p> <p>Each circuit must have basic insulation integrated with a barrier that is grounded conductive or a double insulation. This ensures protection of the circuits and of the users. Due to this factor these are considered safe for a user to operate and do not require extensive testing or strict evaluations due to the enhanced safety and protection behind the design.</p>

\*Information from CUI.com [84]

*Table 25: Voltage Classification*

After analyzing the different voltage classification definitions for the PCB, not to be confused with voltage classes of a device, the circuitry of the system and power source can also be classified. Implementing classification upon the source and circuitry implements a higher level of safety upon the system. The GRAD system will not be labeled as a Limited Current Circuit or a Limited Power Supply, however this doesn't disqualify the system from displaying the characteristics of these classifications. Implementing limiting characteristics of the system can be useful to ensure proper amps or power flow is applied throughout the system. This is useful for certain applications where current or power is a problem. These applications are applied where faults can occur, and protection can be implemented into the system. The Table 26, which is displayed on the next page, outlays the specific limited source and current technologies that could be implemented. Implementing these limiting technologies, the specified classifications can be labeled as non-hazardous.

The definitions displayed in Table 26 outlines the required components when it comes to the current, voltage and power of the limited supply and systems. The ensure proper classification of the system, these guidelines must be implemented to label a system as defined. Since the GRAD system will not implement any limitation circuitry, proper limitation classification of the system will not be implemented. While the system will not be directly labeled with these classifications on the outward appearance of the system, it does not eliminate the GRAD system from displaying these characteristics.

<b>Power Supply Standards (Limited)</b>	<b>Definition</b>
Limited Current Circuits	<p>These circuit are created for when the voltage of the circuits are outside the condition (higher) of the SELV circuits. Limited Current Circuits limit the current of the system. They are designed to handle faults of the circuitry, in which during the fault the current is not hazardous. There are also certain requirements for the system to be a Limited Current Circuit, which are detailed below:</p> <ul style="list-style-type: none"> <li>• Current must be below .7 mA Max AC or 2 ma DC for a frequency below one kilohertz. For those circuits that are above the one kilohertz range multiply the .7 mA by the proportional increase of the kilohertz maxed at 70 mA.</li> <li>• Maximum capacitance of a component must total to no more than 0.1<math>\mu</math>F, for those components of the system which do not exceed 450 both <math>V_{ac}</math> and <math>V_{dc}</math>.</li> <li>• For those components which exceed the above and do not exceed 1500 both <math>V_{ac}</math> and <math>V_{dc}</math>, the components may not exceed a total of 45<math>\mu</math>C or 350mj.</li> </ul> <p>Lastly the Limited Current Circuits must follow the same insulation and separation guidelines as laid out by the SELV circuits above.</p>
Limited Power Source (LPS)	<p>These sources are designed using various methods to have a specific output voltage, current, and power. Due to this is short circuit current also is limited. These systems that obtain LPS have decreased chances of shock, fire or user harm and hence are not labeled as hazardous. These sources must have internal limiting factors or have external systems that limit the current that the output receives. Limited the internal power can be achieved by limiting the power through the components of the power supply, through linear or non-linear impedance components, or a regulating network. Lastly, fuses or circuit breaker can be implemented however certain requirements apply if used.</p>

\*Information from CUI.com [84]

*Table 26: Power Supply Classifications*

## 4.1.9 Coding Standards

Certain standards will have to be followed while coding to have a successful project. A well-defined and standard style of coding known as coding standards are needed to be maintained by the team to have good software development for the project. The coding standards are important in any software development to avoid certain negative effects such as performance issues and security concerns [86]. The main purposes of having coding standards are [87]:

- It helps to detect error and reuse the code easily
- It helps to increase the efficiency of the software developers
- It gives a consistent appearance to codes that are written by different software engineers
- It helps to reduce the complexity of the code
- It helps and improves the code so that it is easily readable and easy to maintain

To summarize, the goal of coding any program is to make the task efficient and faster which can be achieved by identifying the problem correctly in the first place. The second step is to design your code in such a way that is it readable to the other user that is going to use your program that includes good comments in your code. If you write a code that works perfectly the way you expected it to, and the user does not understand your code, likely, they will not consider using your code.

Each organization has some specific coding standards. Some simple and most important coding standards will be discussed in this section. The usage of limited global variables standards tells about which data types cannot and can be declared globally. The value of the variable might get overwritten unknowingly if the variable is declared globally. Having a proper indentation is mandatory to improve and increase the readability of the code. White spaces should be used properly by coders to make the code readable. There are some of the spacing conventions such as a proper indentation should be maintained at the beginning and the end of each block in the code, there must be a space after giving a comma between two function arguments, if there is a nested block in the code it should be properly spaced and indented. Additionally, all braces should start from a new line and the code following the end of braces also start from a new line [87]. When another developer is reading the code, the code written by a programmer should be following some name conventions.

As mentioned in the prior paragraph, using an understandable and meaningful name for a variable helps others to understand the reason for utilizing it. While using constant names the programmer should always be using all capital letters for it. It is best to use camel case that starts with small letters when naming a function or a method. Also, the function or method name must be describing the purpose of using that function. The function should not be lengthy because it becomes difficult to understand, so it is better to break a large function into smaller functions. This will ensure to manage bugs easily. The code should also be well documented. The code should have comments for every functional line. The comments should describe what is happening and how it is being done. It is easier to return

0 or 1 for a function when an error is encountered in the function which makes it easier to debug. The conventions and standards discussed in this paragraph are general.

There are several advantages of using coding standards. It helps to reduce the development time and also increases the efficiency of the software that is being developed. The coding standards also helps to detect errors in the early stages, so that the developer can correct the bugs in the source code easily. By following the coding standards appropriately, anyone can understand the code as it is consistent and is easily maintained. Also, anyone can modify the source code at any point. One more advantage of utilizing a coding standard is that it is cost-efficient. The developers have the opportunity to reuse the code whenever needed if the code is clear and understandable. This reduces the efforts that would be put into the development and thereby reduces the cost. To avoid the risk of failing a certain project, implementing coding standards will reduce many problems in developing the project.

You must choose a language with which you are familiar from before. If you write a program in a language in which you only have little knowledge might get you in trouble if bugs are found in the program. It is better to stick with the language you are aware of. When writing a program, make sure to test it. Here is where unit testing plays an important role. As you write your program is it important to test your program part by part which makes it easier to fix if any bugs are found. This way you will save time and your program will likely work as expected. Once you are done with testing individual portions of your program, it is important to test your program in the integration process, that being said integration testing is an intermediate step before the final testing. The way you write your program determines your ability to solve the problem. Once your program passes the integration testing, you will need to combine and do the end to end testing to ensure that the final product performs as expected. As you can see, I have mentioned a lot about testing, this is because in real-world your program depends on how it performs. Moreover, when you write your program you should make sure that it can be altered for future additions.

There might be some pitfalls that may occur such as lack in confidence while writing your program. You might get frustrated and may not have confidence while writing your program if you won't be able to solve a bug in your program. You should keep in mind that programming takes time and requires patience. The best way to avoid this pitfall is to keep debugging your program and asking for help from others if possible. Another pitfall that might occur is that the program you wrote might not perform the way you expected. In order to make sure it performs as required make sure to check every step in your program while coding it. It is very important that you use the resources in order to get your program working. Apart from the pitfalls mentioned above, there may be several other pitfalls that might occur in your program. The best way to avoid any pitfall is to test your program at each step.

The team will strictly be following all the coding standards that were discussed in this section to build the GRAD system. As stated in the prior paragraph, in order for the project to be successful the coding standards must be followed. Therefore, by obeying the coding standards it will ensure that the team will be able to do all the coding utilized in building the GRAD system. successfully. In a nutshell, a software developer should always follow the coding standards as they play an important role in any software development.

## 4.2 Realistic Design Constraints

### 4.2.1 Economic Constraints

Economic constraints are the limitations put upon the design, assembly and creation of the system due to monetary constraints. These constraints put on the systems factor into the part selection due to component prices, system assembly, and shipping. With this factor being implemented certain parts or technologies that are desired cannot be implemented into the system given the cost constraints. After assessing the current financial situation through Group B, a decision has been made for a strict aim of \$600, which will be capped at \$700. This provides \$100 barrier for any desired or last-minute design changes. Overall, implementing these required constraints upon the system may have some impact upon the operation of the system.

### 4.2.2 Power Supply Constraints

Power Supply constraints are the limitations of the system due to the power that the system is provided. Due to the monetary constraints the GRAD system is only implementing a solar panel into the system integrated with a battery storage system. No other power sources will provide power to the system. Implementing another external power supply, such as a house electrical outlet, would be an expansion of the current project as it would increase the price and complexity of the system. The group decided implementing solar power into the system displays the projects aim toward newer and greener technologies. However, this will limit the power supply for system usage. The solar charging totals will greatly depend upon the world location of the GRAD system to how much solar energy will reach the system. Solar panels are also greatly affected day to day due to certain weather conditions that can occur. This will have an impact upon the GRAD system power generation. The system will implement low power techniques and systems across the GRAD robot to extend the battery life of the system, however constant uninterrupted power is not likely for this current design. These factors could affect the performance of the system, however full functionality of the GRAD system is expected.

### 4.2.3 PCB Constraints

When designing a schematic there aren't many constraints when it comes to designing and spacing because of the breadboard. However, when transferring the schematic circuit into a printed circuit board more requirements and constraints come into play to ensure proper functionality of the circuit, as well as increased safety for the user and of the components of the system. The traces of a PCB are essentially the lines on a circuit board, they are the wiring, the copper, the insulations and even the fuses within that make up the circuit board. The PCB traces just like any other element (such as a wire) have resistance to them, which can be calculated using:

$$Resistance = P \text{ (Resistivity of the Material)} * Area$$

This formula can be used to calculate a base restiveness of the circuit due to the material of the traces. The traces also have a certain width in the trace itself and should have a

certain distance from trace to trace to ensure proper functionality of the circuitry. The trace width can be calculated by first finding the area that would be associated with the traces, then that area can be used to find the width of the traces. To find the area the equation below is used:

$$Area \left[ \text{mils}^2 \right] = Current \left( k * (\text{Temperature Rise})^b \right)^{1/c}$$

The constants “k”, “b”, “c” are for the IPC standard 2221 and k is different depending if the layer is external or internal. For an external layer k=0.024, b=.44, c=.725. The internal layer has the same “b” and “c”, however the constant k=0.048 After the Area is calculated this can then be used to calculate the width of the traces [88]. The requirement for finding the total width of the traces requires the thickness of the material in ounces. The formula is displayed below:

$$Width \left[ \text{mils} \right] = \frac{Area \left[ \text{mils}^2 \right]}{Thickness \left[ \text{oz} \right] * (1.378 \text{ mils/oz})}$$

These formulas can be used to calculate the constraints of the PCB. Overall, the traces can affect many components of the PCB board. The resistance can be affected as seen from the equations above which can affect the efficiency of the entire system. The width, thickness, and area of the traces can end up affecting the size of the board.

#### 4.2.4 Environmental Constraints

The GRAD system will not negatively affect the environment. The main purpose of creating an autonomous outdoor garbage bin is to ease people's lives. Initially, the design of the power will be coming from the solar panel. Due to the system running off solar power, the weather could affect the generation of the solar panel day to day, affecting the overall efficiency of the GRAD system. Also, the use of an Infrared sensor might harm human's eyes. The team is doing its best to not harm any person or animals when they are nearby the sensor. The IR sensor runs on a high contrast differential gradient, which will require lines to be put into the environment. Certain environments may make this difficult and could affect the overall functionality of the GRAD system. With implementation of the line following technique, as previously discussed requires the high contrast line to be laid throughout the environment, this could cause decreased visual appearance to the environment. This could cause issues in neighborhoods with Homeowner Associations.

#### 4.2.5 Social and Political Constraints

The primary goal of this garbage and recycle autonomous disposal system is to eliminate the physical demands, incorporate ease, and facilitate efficiency by providing an automated controllable system to schedule trash bin curbside placement. Socially and politically, the nature of this project does not affect any specific job market. This project is entering into

a new sphere of home automation for the user's ease. It has a positive impact on users such as the elderly to whom this autonomous system elevates the physical demand of pushing the heavy garbage out. There is no huge impact on the change of life however it helps reduce the task load of a user and brings ease to everyday life.

#### **4.2.6 Ethical Constraints**

The ethical constraints of the system are those put on the system that displays integrity of the device and implements "what is right". The GRAD system implements features to the device that will protect the user and other objects from harm, such as object avoidance sensors, implementing no hazardous voltage into the system, and storing the majority of the electronics in a compartment within the GRAD system. These constraints as well as those defined in the Health and Safety section below impact the overall design and functionality of the system. In terms of the GRAD system implementing compartmentalizing of our devices to keep the user free from harm increases the cost of the system as well as the weight of the system, which would decrease the efficiency of the system. The system will be assembled by the team, Group B, however, the parts will be ordered from manufacturers and assemblers, which follow strict standards and guidelines for safety and protection. Implementing these devices into the system and by Group B also aligning to these standards and guidelines implement ethical practices within the system. The system has been created and designed to assist humans in their everyday lives, and each step taken in the process is to assist in everyday life, not to harm it.

#### **4.2.7 Health and Safety Constraints**

We are adding different types of technologies in our GRAD system to ensure the health and safety of our customers and in the development of this project. Our design includes sensors to detect objects such as humans, animals, vehicles, etc., to stop at a safe distance to avoid physical contact. It is very important for the health and safety of the customer as well as other objects in the environment of the GRAD system to detect where it is going. Since the GRAD system will move from its docking location to the curbside to deliver the trash can, it could become a safety hazard if the GRAD system is not able to sense the object around itself. It will need to know its current position as it moves while avoiding objects in the way by using ultrasonic sensors, or a camera vision system.

Besides the risk of physical contact, there is also a risk of electric mishap. We are following standard guidelines and taking steps to ensure the electronic components of our GRAD system are designed and tested with safety in mind. The power supply implements voltage and charges regulation to ensure the proper functionality of the solar panel and the internal battery. The PCB is designed and created using EAGLE, an Autodesk product, which is standards approved software. Then after design and creation, the PCB is sent to OSH Park for design, manufacturing and then assembly. The manufacturer will follow these standards to ensure proper functionality and safety of the system.

While ensuring the safety of the customer and environment objects through creating a safe design and implanting good standards, we will also focus on the health and safety of the group members especially with the current pandemic of Coronavirus disease. To ensure everyone's health, we will be adapting the guidelines of the Center for Disease Control and

Prevention. Keeping parts of our project clean and disinfect, avoiding close contact with group members, and being proactive in taking measures to safeguard the health of our group members.

#### **4.2.8 Time Constraints**

Time constraint was not a big problem until later in the semester. We as a group had a strict timeline planned to have our project completed on time with the maximum amount of testing and verification done. However, due to the COVID-19 outbreak, ordering and receiving design parts on time will affect the overall design and construction timeline of the project. It has already impacted our ordered parts in Senior Design 1 for some parts. We intend to make up for the time in Summer as we are going to take Senior Design 2 in Fall.

In regard to the paper report for this Spring semester, we have successfully met our goals of completing all milestones on time with research and some testing of the parts while enduring the current pandemic.

In terms of the second phase of building our project in Senior Design 2, we predict the current situation will negatively affect the timeline due to the uncertainty of having lab resources available necessary for the construction of our project. Due to this time constrain, the requirement to have an implemented PCB in our project has to be waived. Although we will still design the PCB but due to the closing and slowdown of some fabrication manufactures, it will not be possible to receive the PCB on time or delivered at all. Instead, we are will be doing putting together our electronics by breadboarding. There is also the uncertainty of how long the social distancing will continue which will impact our group from meeting up to work together on the project.

To mitigate the impact on our timeline, we as a group have actively sought ways to make up for the loss of time. Although not having lab resources will affect the quality of our testing and building, we are planning to purchase basic tools such as multimeter, soldering machine, and additional small equipment that we can afford to still work on our project. This time constrain not only has affected our timeline but also affects our budget as now we have to purchase extra equipment that would have been available to use in the UCF laboratory. While we cannot meet up to work together until further notice on social distancing, we as a group have made some plans to work independently from our house environments on sub-systems and possibly have most parts assembled together by shipping to each other.

#### **4.2.9 Testing/Presentation Constraints**

With the current pandemic outbreak of the Coronavirus disease (COVID-19) affecting the daily livelihood, it also has impacted education intuitions. It has a direct impact on our project as we are not able to currently meetup as social distancing is advised to avoid the spread of Coronavirus. We are trying to adapt to a new way of learning, working together online due to current circumstances and as a result, we are limited to some aspects. Depending on how long until a vaccine is found to reduce the spread, we would have work on our own in building subparts of the project. It could also impact our presentations as it will be done online and not have physical interaction. We are limited in the use of



laboratories as public-school institutions are closed making it hard to access equipment and tools to build and test our project. We would need to find ways of purchasing our tools.

As discussed previously, testing is a critical part of constructing our project. We have already experienced the impact during Senior Design 1 as we were not able to receive some parts on time and did not have the lab equipment to thoroughly test. We predict that we will be facing more constraints as the uncertainty of the current worldwide pandemic situation worsens. However, we as a group are trying to do our best to lower the negative effect on our testing by purchasing our tools. The group will not be able to meet up to troubleshoot and work together on resolving issues, however, planning on shifting to regularly meet online and work on sub parts individually.

In terms of the presentation, since everything is moved to an online standard, we have to make some necessary changes to adapt to online conferences. The university has provided access to Zoom online conference service that allows us to discuss our project within the group as well as meeting with the faculty. We predict that much of our presentations and meeting will be done through Zoom and depending on how long the shutdown of school continues, we might be submitting videos to demo our project. The current situation has placed many constraints to our usual way of working, however with the team's flexibility to move online and willingness to adapt with the current situation, there is an optimistic outlook in our ability to complete this project.

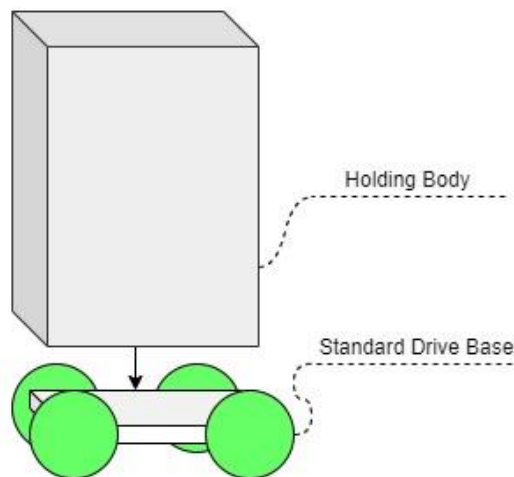
## 5.0 Project Hardware and Software Design

The design of the system is essential to the proper functionality, safety and efficiency of the system. The design of a system is broken between the hardware and software of the system. This section outlines the physical components and design that are implemented in the GRAD system, such as the power supply (including the battery and solar panel), the printed circuit board, as well as motor integration. The GRAD system also relies heavily on software for proper functionality, action, and communication. The contents in this section also present the software design and functionality behind the design of the GRAD system.

### 5.1 Physical Design

The physical design of the GRAD system has to be simple but effective in its use. We want a prototype that is very close to actual trash bins used by most households. While also considering our tight budget, we shifted our thoughts of designing the physical structure to what is currently used in most households and also utilize readily available trash cans to modify to our needs in order to reduce our overall cost. The GRAD overall body being a trash can has to be modified to add a drive system, store electronics securely, and add solar panels for battery charging.

The drive base has to be added at the bottom of the GRAD system and has to be sturdy enough to hold all of the weight above. As per our research finding in our previous section about the drive systems, we need to integrate the standard drive with the rest of the structure being a trash can. From our research, we know that standard drive is very flexible in manipulating to a design so our approach of integration will focus on finding the best available trash can body to easily combine the drive base with the trash holding body as depicted in the Figure 10 below for visual purposes. While finding the best trash can body for our GRAD system, we will also consider looking into trash cans with built in wheels which will also further reduce cost and allow us to easily modify and implement standard drive.



*Figure 52: Visual depicting GRAD Holding Body & Standard Drive*

The electronics including the microcontroller, PCB, and batteries should have a separate compartment from a trash holding compartment. The body of the GRAD system should be divided into two separate compartments, one located at the bottom for the main electronics and one right above for holding the trash. The trash compartment at the top will create ease in designing as it will allow the user to use it as any other normal trash can but it will serve a greater purpose for our electronics. It will secure and safeguard the electronics from daily trash use by the user and avoid any mishap into damaging the electronics. Although the main electronics will be secured at the bottom compartment, it will create unease in access for maintenance. In order to safeguard the electronics but also make it accessible, the top compartment will be designed as such to be easily removable and attached back with the GRAD body.

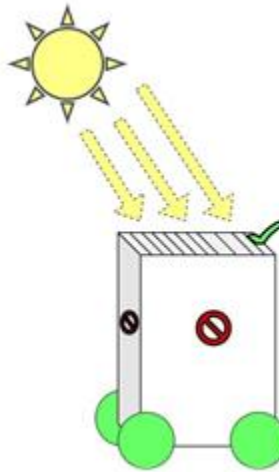
Besides securing the main electronics, our design of the GRAD system will also hold different types of sensors at different locations mostly at the external side of the structure. The wiring has to be appropriately sealed and should be placed on the inside of the GRAD body to avoid any damage from wear and tear and also tough weather conditions.



*Figure 53: Side view drawing Illustrating Compartment A & B*

Another important component of our design is considering the placement of the solar panels. In order to gain the optimal sunlight to have our solar panels charge the batteries, we think the solar panel should be placed at the top on the lid instead of the sides. The GRAD system's position will be stationary for most of the time and as the Sun moves across the sky, the sides of the GRAD body have a lower chance of receiving the maximum sunlight compared to the top side. No matter what position the sun is throughout the day, we know that the top side of the GRAD system will receive the most sunlight as seen in Figure 54. As our project includes a renewable resource and especially on a part of the GRAD body where it is used quite often for opening, we are thinking of creating the lid automated. So whenever a user approaches the GRAD system, the lid will open automatically avoiding the user from accidentally tampering with the solar panels. This is

not necessary; however, it will be one of our stretch goals. It will require two additional servos and a mechanism to extend as servos push to open in controllable fashion.



*Figure 54: Visual depicting solar panel at the top side*

Besides the position of the solar panel placement, the quality of the lid holding the solar panel has to withstand the daily use while also holding solar panels intact. Although a few ideas were discussed for opening the lid at a different position in order to avoid opening the lid from top with solar panels, we thought to stick with the original idea of making our design as similar as possible to our current trash cans used. It will also reduce the amount of modification made on the trash can body however makes the task of adding a solar panel on the lid difficult. Our design will allow the user to use the GRAD system to put in trash as any other trash can but smarter in taking the trash out.

The complexity of modifying a readily available trash can body with a drive base, adding electronics into compartments, and fitting solar panel and sensors will require attention in selecting the parts. As a result, necessary research will be done to acquire the best available and cost-effective parts.

### **5.1.1 Drive Base Design Configuration**

#### **Integration of Standard Drive**

Knowing that standard drive is very flexible to integrate with different designs, our GRAD base design will manipulate the use of trash can built-in wheels with addition of front wheels. With already built-in wheels in the back, the drive base would need either two or one wheel in the front for steering. A standard drive usually has four wheels with back wheels powered by a motor source and front two with a mechanism to control the steer. Adding a steer mechanism to our drive base design will be difficult due to our budget constraints.

To overcome our budget constraint of adding a steering mechanism, we will discuss a possible solution. We know we can't use a wheel that is constrained by its ability to turn and want a wheel that is independent in its movement. For a wheel to be independent in its

movement, the wheel should be able to rotate freely in 360 degrees under a load. This rings a bell from our daily use of office chairs which have wheels known as casters that allow the chair to move in any direction free of constraints when a force is applied to a desirable direction. As described in a blog by Douglas Equipment, the exact type of wheels we are looking for are called swivel casters. Swivel caster allows the wheel to move freely in any direction due to the center hub with ball bearings. We can utilize the kinetic mechanics of a swivel caster wheel to our benefit to avoid adding a costly steering mechanism.

The decision on using swivel caster wheels for the front steering rises another point in our design of the number of wheels needed. Due to the added benefits of a swivel caster wheel being able to rotate in any direction while also being able to handle load, we can also consider a design with just one wheel in the front middle for steering and back two motorized wheels for push force. We will discuss in the next section of our research of the pros and cons with three wheels versus four-wheel drive.

### **Utilizing Trash Can Wheels for Standard Drive Base Design**

After researching different types of trash cans, we noticed most outdoor trash cans sold have built-in wheels to easily roll the trash can. With our design goal of minimizing cost while still meeting our goals, we think our drive base design of standard drive should utilize the built-in trash can wheels to further reduce cost. From our drive systems research, we know an estimated cost of building a standard drive to be about \$82.00 which includes four 6 inch tires and two motors, however if the trash can wheels are considered in our drive base design, the cost could be further reduced by subtracting the cost of two wheels which is about \$16 - \$20. This cost reduction will help us stay under or budget or utilize the money saved for another better-quality part.

### **5.1.2 Motor Adjustment**

In order to attach two motors to the GRAD body, we have to take precise measurements of the space available. The shaft that connects the two tires has to be taken out and each motor will be attached to each tire. In order to hold the motor in place, we will have to create a motor casing that will attach it to the body. We are also looking into design 3-D printed motor housing but due to the current COVID-19 pandemic and the university being closed, we might not rely on this option. The Figure 55 below shows a conceptual placement of the motors on the backside of the GRAD body with the two tires.

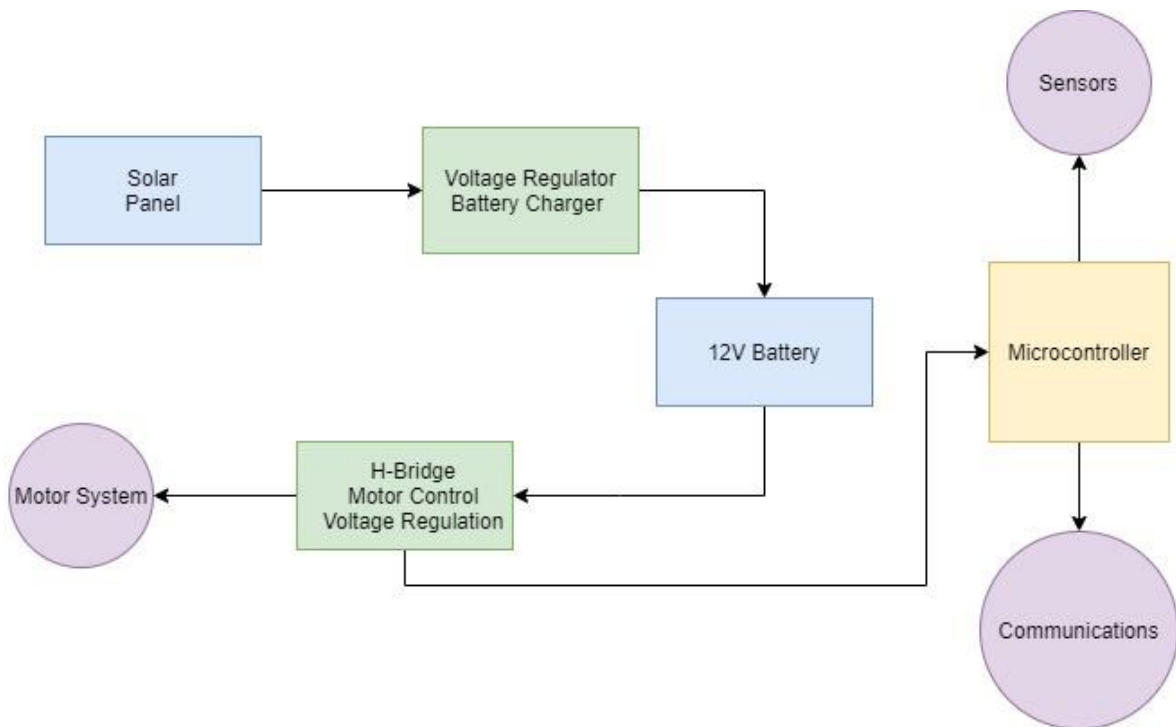


*Figure 55: Conceptual placement of Motors*

The motor's shaft will be connected to a hub which will be screwed into the wheels. The motors usually come with a small shaft and depending on the fitting, there might be a need to make it longer by attaching another shaft. Once the motors and the wheels are connected and attached to back of the trash can body, the wires will be run into hole created in the trash can to the motor controller inside.

## 5.2 Hardware Design and Power Flow

The hardware of the system is the backbone to the system, it allows for the operations to happen. The main functionality of the hardware design is to ensure proper power supply to the system, with consistent regulation, while also ensuring proper action when the system requires it. The hardware is any physical needs of the system, without the hardware functioning properly the system cannot operate. The hardware can be divided into different subsystems. As seen below in power flow block diagram, Figure 56, the solar panel is the main source of power within the system.



*Figure 56: Power Flow Design*

Each of the subsystems can be broken down and discussed as individual systems. The testing of the components of each subsystem will be done to ensure the accurate functionality of each system. This will ensure that when integration of the system happens, the system's individual parts are functioning properly. If the integrated system has issues, but each subsystem properly works, then certain testing and diagnostic systems can be implemented to determine, examine, and correct the issues which arose during system integration.

The first section to analyze is the power supply and voltage regulation components of the system. This is the backbone of the project, the power flow of the system ensures that the external devices and software components have the correct current, power, and voltage to ensure proper functionality. Since the GRAD system runs solely based on solar power and a battery it is essential to ensure proper power flow within the system to allow the system to operate as planned with reliable functionality.

## 5.2.1 Power Supply & Voltage Regulation Design

### Solar Panel Battery Charging Circuitry

The GRAD system implements the use of a solar panel to charge the battery. The battery is used to run the system. The solar panel for the GRAD system is a 12V 30W system. According to its data sheet the optimum voltage is about 19.5V. Testing the circuitry to charge the battery with a 19.5V optimum of the solar panel is displayed below. The circuit with LM317 was tested initially below due to limited resources at the time of testing. The LM317 was the only linear voltage regulator provided by this circuitry testing software that was used at the time. Without on-campus resources provided by UCF such as Multisim. Multisim Live was used to construct and test the circuit below. A diode can also be implemented within the circuitry before the BJT for visual inspection of proper functionality. When testing the system during charging the battery should obtain a voltage that is above that of 12V. This part of the testing will be included in the physical tests of the parts.

The battery requires a charging voltage around 13.8-14.1V to ensure proper charging. The 5K resistor will be reduced to 4K ensure proper charging of the battery. The circuit in Figure 57 is tested through breadboard testing to ensure proper voltage analysis. From the below circuitry both the voltage and current for the battery that is being charged are met. A diode is place before entering the voltage regulator to ensure the proper functionality of the solar panel and the battery charging. This should help eliminate any over and/or undercharging and/or voltage to the system.

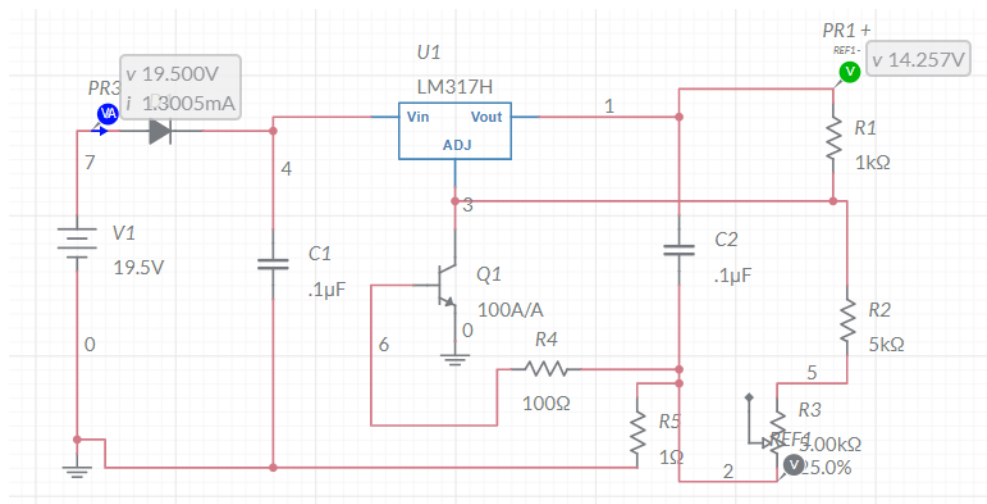


Figure 57: Solar Panel and Battery Voltage Regulator Circuit with LM317

This voltage regulator circuit is the first circuit to be tested. The next circuits to be tested are the other voltage regulators laid out in the part selection. Choosing the best voltage regulator will be essential in the operation of the system.

### Battery to Microcontroller Voltage Regulation Circuitry

The microprocessor has a normal input voltage between 6-20V, however the chip itself has an input voltage around the 5V range. Implementing a voltage regulator circuit will be designed into the PCB for optimal usage. Having these voltage regulators from the battery into the PCB system will be used to ensure proper voltage into the system itself from the battery. The LM7805 voltage regulator has a fixed output of 5V from an input range of 7.5-35V. This voltage regulator steps the voltage down to allow for proper input voltage to the ATmega2560.

This voltage regulator circuit in Figure 58 displays an input of 12V from the rechargeable battery that will be supplied by the solar panel, then step down to a voltage of 5V to ensure proper voltage into the microcontroller. From the battery to the microcontroller subsystem, the LM7805 voltage regulator can be implemented into the system.

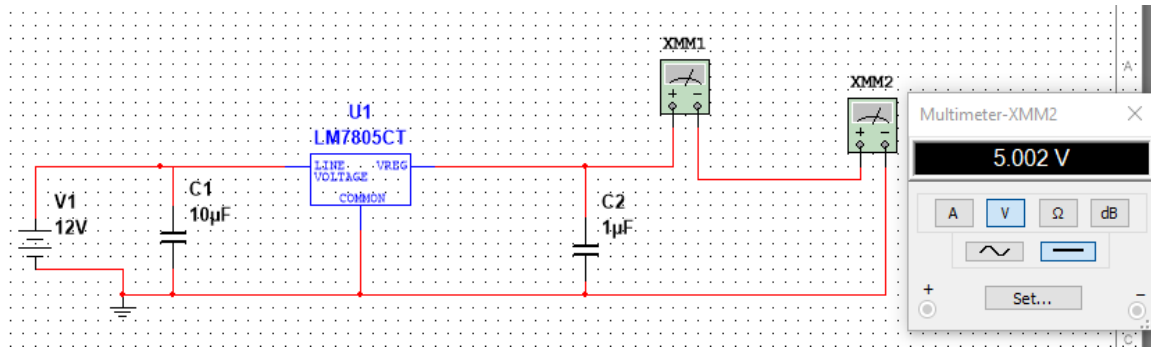


Figure 58: Battery to Microcontroller Schematic

After the microcontroller receives proper voltage regulation the output of the microcontroller pins will be assigned certain devices or components such as the HC-SR04 sensors and any Wi-Fi modules. These systems and devices are connected to ensure proper voltage and functionality within the system. The output voltages from the microcontroller have the same voltage levels that are required for some of the components that will be connected. Since a layer of the PCB will be 5V it ensures that no more voltage regulators are needed for the connection of those sensors to the microcontroller that operates at the 5V voltage level. Once the regulation happens once, these sensors can be connected to the net 5V value.

### Sensor Voltage Regulation

However, some of the sensors that the system requires operate at a voltage level that is of 3.3V rather than the typical 5V which the system operates on. This will require voltage regulation to ensure the proper functionality of these sensors. This requires the implementation of a voltage regulator. The circuitry simulation in Figure 59 implements the LP2985, which is a low-dropout (LDO) fixed voltage regulator. The input voltage for this regulator can range anywhere between 2.2V to 16V and it will regulate a fixed output



voltage of 3.3V no matter the input voltage within the specified range. Implementing the below regulator is beneficial to the system as other components except the capacitor are required. This makes the system easier to regulate with less failure of other components.

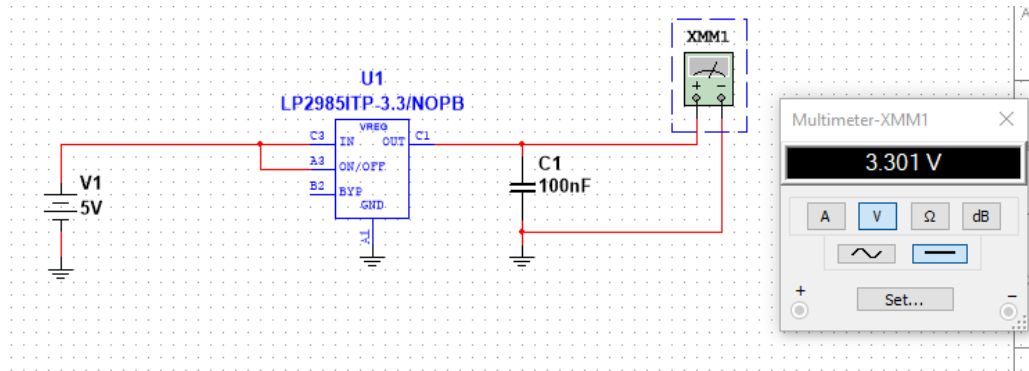


Figure 59: Voltage Regulation from 5V to 3.3 V

### Alternate Circuitry for Battery to Microcontroller Voltage Regulation

The motors that the system uses also require a specific voltage that can be drawn from the battery. The motors require 12V, aligning these motors in parallel with the battery will ensure the correct voltage of the motors. For proper operating functionality and control of the motors, an H-bridge is implemented into the system. An H-bridge is a circuit that allows for the polarity to be easily changed, allowing for control of the motors. The L298N motor control circuitry includes motor control for the proper voltage but it also includes voltage regulation from the input voltage to an output voltage of 5V. This voltage regulation included in the L298N will ensure proper voltage regulation between both the battery and the microcontroller and ensure the proper functionality of the motors. Since the L298N device will already be implemented into the system, the voltage regulation from the input 12V to the output of 5V that is contained in this device will be implemented. Rather than having both the previously analyzed voltage regulation circuitry and a motor control system separate, implementing the L298N integrates both circuitry into one device which allows the system more efficient, economical, and reliable while requiring less space. This will ensure proper functionality and reliable voltage regulation. This device can be implemented to the PCB and will be placed between the battery and the microcontroller.

### Power Supply Integration

After simulation of the regulation from the solar panel to the battery as well as the simulation from the battery to the microcontroller, the overall system can be integrated for simulation and testing. These two circuit element subsystems are integrated together to form the voltage regulated power supply to ensure proper voltage throughout the GRAD system and proper charging of the battery. Since many voltages are implemented throughout the system, proper and accurate voltage regulation and control is required. Since the solar panel has an output of 19.5V, the battery obtains a 12V-14V range, the microcontroller and certain sensors operate at 5V and the communications systems operate in the 3.3V range, supplying proper voltage throughout the system is essential. After

receiving final products, including the PCB, voltage testing is applied at each point in the overall GRAD system to ensure the voltage level is correct and the system is operating accordingly. Even if the system is operating properly once constructed, operating at voltages above or below the intended system voltages can cause harm the device itself or a user. It could also decrease the life of the system.

## 5.3 Software Design

A major component of the GRAD system is the accompanying mobile application that allows the user to schedule the time for the outdoor garbage bin to drive itself to the curb. Furthermore, the mobile app will also allow the user to check the trash level if it is empty or full. The notification system will be a bonus for the mobile app that will inform the user if there is any obstacle detected in the way. The software needs to prioritize user's safety apart from the general functionalities of the mobile application. In this section, various functionalities and the logic behind the software will be discussed. The mobile application will be developed using Android Studio platform for ease in development for the mobile app.

### 5.3.1 Software Logic Diagram

The Figure 60 shown below illustrates an outline of the logic that will be managed by the back end of the mobile application with the notification system. Apart from displaying or notifying the user, algorithm and other functions will be coded in order to compare the scheduled time that will be obtained from the database and the current time so that notification with a message is popped on the mobile application and then the outdoor garbage bin will drive itself. The logic process shown in the figure will be occurring every minute to read the time from the database.

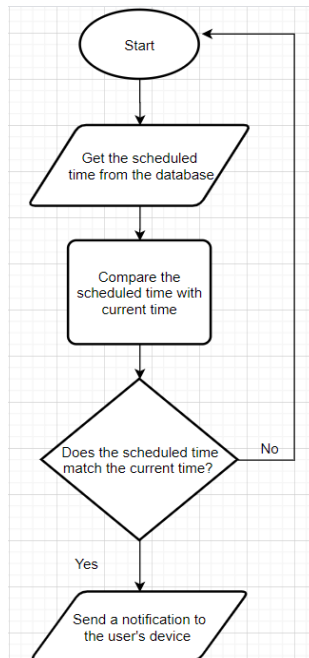


Figure 60: Software Logic Diagram

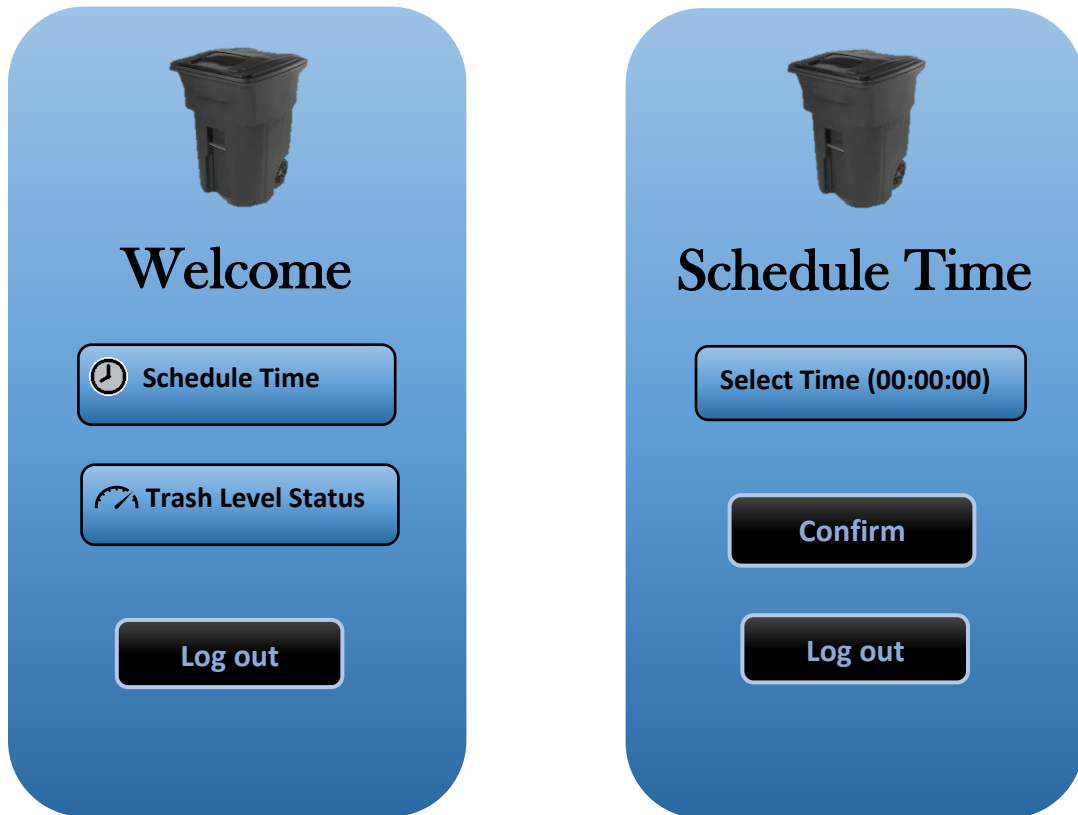
### 5.3.2 Application Overview

The accompanying mobile application for the GRAD system will comprise of some displays and functionalities. For any basic mobile application that is account-based, the mobile application for GRAD system will have a secured login page that will allow the user to login to a specific account. By having a secured login page, it will ensure that the data or information stay confidential so that the privacy is maintained. When a new user is trying to schedule the time for the outdoor garbage bin to drive to the curb, the new user has to register first. Different users will be able to login to their secured accounts once their account is registered. The outline of the mobile application for the login page for the GRAD system is shown in Figure 61 below. Several features can be added to the register and the login page of the mobile application to make it more fancy and secure. For instance, a security question can be asked to the during registering or if the user forgets the password while logging in it can change its password by answering the security question the user answered while registering. If the time permits, the team will decide to implement these extra features for the login and registering page. A simple outline of the registration page of the GRAD mobile application is shown in Figure 61 below. The mobile app is going to be developed in Android Studio. The mobile application for GRAD system will communicate with the microcontroller through WIFI module.



Figure 61: Login and Register page of the GRAD mobile application

Once the user has registered by entering their credentials, the mobile app will redirect the user back to the login page to log in with the credentials that the user used while registering username and password. Once the login is successful, the app will redirect to the main page where the user will be able to schedule the time and see if the trash is full. A simple outline of the main page of the GRAD mobile application is shown in Figure 62 below. The two tabs on the main page as shown in the Figure 62 allows the user to select between two options: Schedule time and Trash Level Status. When the user chooses to press the schedule time button on the homepage, it will redirect the user to the schedule time page. A simple outline of the Schedule Time page of the mobile application is also shown in Figure 62 below. The Schedule Time page has a select time box where the user enters the time it wants the outdoor garbage bin to drive itself. The user then has to select the button to confirm once it enters the time. As shown in the Figure 62 below, the page also has a log out button which allows users to log out of their account if they wish to.



*Figure 62: Home Page and Schedule Time page of the GRAD mobile application*

The homepage also has a “Trash Level Status” button which redirects the user to the trash level status page, where the user can see if the trashcan is empty or full. The trash level status page has a button “Drive to the curb”. If the status of the trash level shows full, the user presses the “Drive to the curb” button that will allow the outdoor trash bin to drive itself to the curb. This is another option for the user to operate the outdoor trash bin manually.

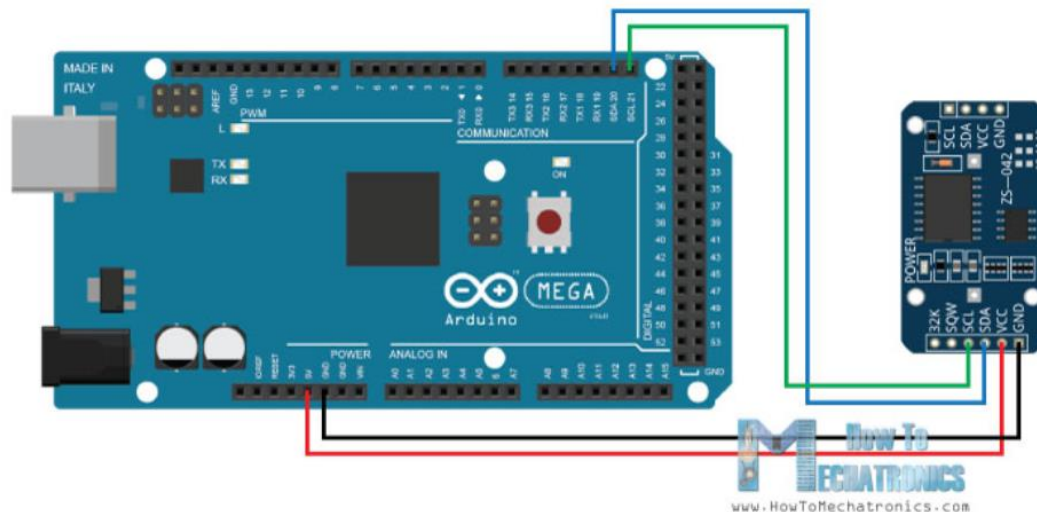
## 5.4 Microcontroller Design

The microcontroller that we have chosen, the Arduino Mega 2560, will have to be interfaced with a Wi-Fi module, real-time clock module, motor drivers, and power supply. The schematic showing the wired connections between the Arduino Mega 2560 and real time clock/Wi-Fi modules are shown below.

### 5.4.1 DS3231 Real Time Clock Module

A real time clock module is necessary to deploy GRAD to the curb at a specific date/time. Although the Arduino Mega 2560 has its own built in clock, a separate RTC is needed to keep track of the current time in case the microcontroller is reprogrammed or in case it is disconnected from the main power. The RTC module that we have chosen is the DS3231- it is an accurate, low-cost I2C device with an integrated temperature compensated crystal oscillator (TCXO) and crystal. The DS3231 operates on 3.3 to 5 Volts, so a simple CR2032 battery would suffice as a power source. The RTC keeps track of time in seconds, minutes, hours, days, months, and years [89]. In addition, the RTC takes leap years into account and it adjusts for months with less than 31 days. The clock can be set to follow either the 24-hour format or 12-hour format with an AM/PM indicator. Moreover, the module comes with a programmable square wave input in addition to two programmable time-of-day alarms.

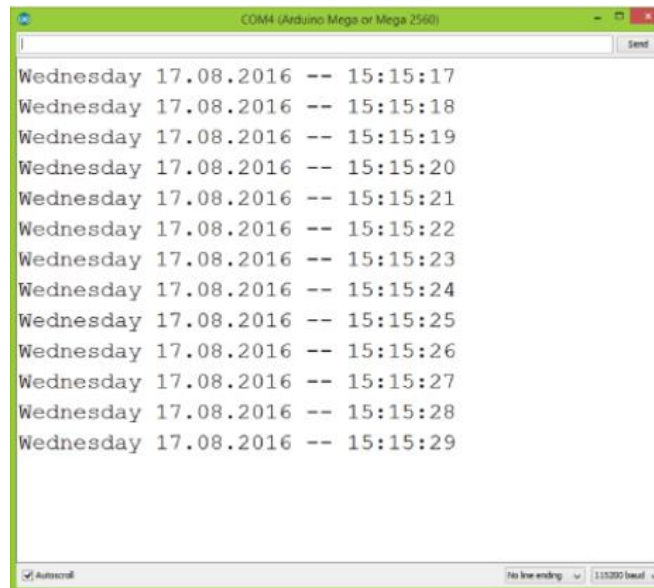
An I2C bidirectional bus is used to serially transfer address and data. The connection to the Arduino Mega 2560 is simple and only requires four wires, as shown in Figure 63 [90]. One wire is used to connect the two grounds together, the second wire connects the module's VCC to the Arduino's 5 V power pin, the third wire connects the serial clock pin (SCL) to Arduino's D21 pin, and the last wire connects the module's serial data (SDA) pin to Arduino's D20 pin.



*Figure 63: Arduino Mega to DS3231 Connection.  
Reprinted with permission from HowToMechatronics*

After the pins of the RTC module and the Arduino Mega 2560 have been connected, they must be programmed to work together. To make the programming between the Arduino and I2C module easier, we will use an existing library for the DS3231 RTC which can be found online. One option is to use the library created by Henning Karlsen, which can be downloaded from his website, Rinky Dink Electronics [91]. The library is licensed under a CC BY-NC-SA 3.0 (Creative Commons Attribution NonCommercial-ShareAlike 3.0 Unported) License, which means that users have a right to share, use, and build upon the library.

The first step to programming the RTC module is to create a `setup()` function that establishes the serial connection and sets the baud rate, initializes the RTC object, and sets the current date and time. There are built in functions to assist with each of these tasks: the `Serial.begin()` function establishes the serial connection and it takes in the baud rate as input (115200); the `rtc.begin()` function initializes the RTC object; and the `rtc.setDOW()`, `rtc.setTime()`, and `rtc.setDate()` functions set the day of the week, time in 24-hour format, and date in month/day/year, respectively. To check if the RTC module is correctly configured to the Arduino microcontroller, the Arduino serial monitor can be used. The serial monitor is part of the Arduino IDE- it is a separate pop-up window that acts as a terminal and sends/receives serial data. Data can be sent in both directions- from the Arduino Mega 2560 to the RTC module, and from the RTC module to the Arduino Mega 2560- and it is represented as a series of 1s and 0s sent over a wire. Inside of an infinite loop, it is possible to print helpful information to the serial monitor to check the accuracy of the RTC module, as shown in Figure 64 [90].



*Figure 64: Arduino Serial Monitor  
reprinted with permission from How To Mechatronics*

The Arduino Serial Monitor prints the results of the `rtc.getDOWStr()`, `rtc.getDateStr()`, and `rtc.getTimeStr()` functions which retrieve the day of the week, the current date in dd:mm:yy

format, and the current time in hh:mm:ss format. A delay of one second exists between printing each line. Even if power is disconnected from the microcontroller, the Arduino Serial Monitor will continue to print out the dates and times as before.

In order to reduce battery consumption of the microcontroller, it is possible to engage low-power modes while waiting for interrupt events to occur. The RTM module has two programmable alarms, represented in hardware as two sets of registers. To wake up the microcontroller, all that is needed is to write the time of the required alarm, enable the interrupt for the RTM module's alarm, and connect the RTM module's INT output pin to the microcontroller's interrupt input pin. According to the official Arduino Reference text [92], the digital pins that can be used for interrupts on the Arduino Mega 2560 are pins 2, 3, 18, 19, 20, and 21. After the pin connections for the interrupt have been made, the RTM module can fire an interrupt signal at the specified time to wake the microcontroller from sleep mode. After the microcontroller detects the interrupt, it will be necessary to process the interrupt and activate any events that are supposed to occur- in the case of GRAD, we could use an interrupt to keep the microcontroller in low power mode when it is not being used to transport garbage. When the current time equals to the time specified to the RTM's programmable alarm, an interrupt can be sent to the microcontroller to wake it from sleep mode, activate the motor and sensor subsystems, and begin following the line to the curb.

## 5.4.2 ESP8266-01 Wi-Fi Module

The ESP8266-01 has eight pins, making it the smallest ESP8266 module. To connect the Arduino Mega 2560 to the ESP8266-01, we must use six wires to establish six different connections. The first wire connects the ground pins of the two devices, the second wire connects the ESP8266's chip select pin (CH\_PD) to the microcontroller's VCC pin of 3.3 V, the third wire connects the ESP8266's GP0 pin to the microcontroller's ground pin, the fourth wire connects the ESP8266's RXD pin to the microcontroller's RX pin, the fifth wire connects the ESP8266's TXD pin to the microcontroller's TX pin, and the sixth and wire connects the ESP8266's VCC to the microcontroller's VCC pin of 3.3 V. The connections are illustrated below in Figure 65 [93].

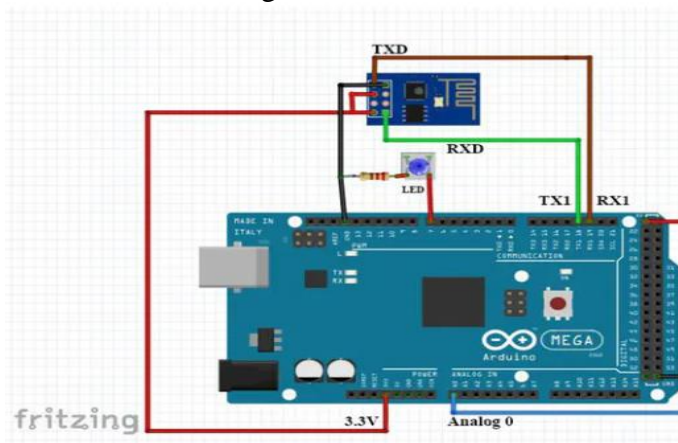


Figure 65: ESP8266-01 and Arduino connection. Reprinted with permission from <https://create.arduino.cc>

## 5.5 Line Following Algorithm

The basic algorithm that line following robots use is outlined in pseudocode below [94] and is illustrated in Figure 66 [95]. To summarize, if the robot senses that the line is too much to the left, then it will compensate by moving to the right. Similarly, if the robot senses that the line is too much to the right, then it will compensate by moving to the left. If the robot is not too much to the left or too much to the right, then it will keep driving itself forward. If the robot detects a junction- meaning that the left and right sensors are on the line- then the robot comes to a stop.

### Pseudocode:

if (robot is to the left of the line)

    turnRight()

if (robot is to the right of the line)

    turnLeft()

else

    moveStraight()

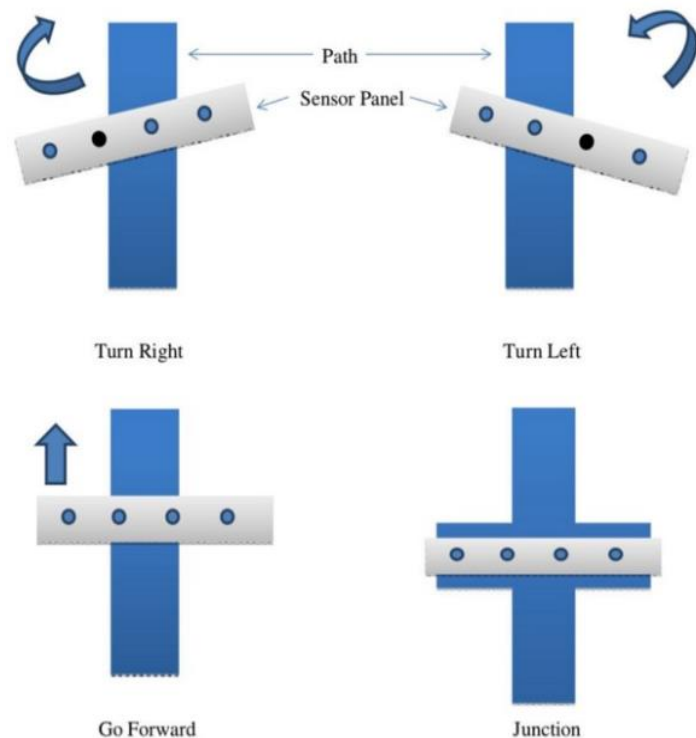


Figure 66: Logic for line following robots.  
Pending Approval

In order to make the robot's movement more precise and flexible, an array of at least two IR sensors should be used to implement line following. The particular sensor that we are using is the IR Infrared Obstacle Avoidance Sensor Module by OSOYOO. The more IR sensors inside the array, the more accurate and smooth the robot's movement will be. Precision is important so that the robot has minimized shaky movements and sharp turns, thus increasing the stability of the robot and ensuring that the robot's technological components do not move out of place while the robot is in motion. The overall flow of the line following robot is as follows: IR sensors detect the path and junction, and the corresponding digital values are sent to the microcontroller. The microcontroller then makes decisions on the movement of the robot and provides signals to the motor driver.



## 6.0 Design Testing and Implementation

### 6.1 Individual Systems Testing

#### 6.1.1 Microcontroller Testing

Due to current circumstances that have resulted from the covid-19 pandemic, we do not have access to any labs or facilities on campus. As a result, our ability to test components has been hindered as we do not have access to necessary equipment: some electrical equipment that we need but are not accessible from home include a power supply, oscilloscope, voltmeter, ammeter, and basic circuit components such as a breadboard, resistors, transistors, and capacitors.

We were still able to test some components, however- for instance, we connected the Arduino Mega 2560 board to our computer with a USB cord and uploaded some sample programs to check that it is properly functioning. We used a sample program provided through the Arduino IDE, called `i2c_scanner`, to test the functionality of our board. With no i2c device connected, the program correctly printed out “No I2C devices found,” rather than printing out the address of any non-existent I2C devices. The output of the Arduino Serial Monitor is shown below in Figure 67. Inside of an infinite loop, the program keeps checking for the presence of I2C devices using predefined functions in the Wire library, including the `Wire.beginTransmission()` and `Wire.endTransmission()` functions. The `Wire.beginTransmission()` function takes the 7-bit address of the device to transmit to as a parameter, and it uses that address to start the transmission to the I2C slave devices. The `Wire.endTransmission()` function ends a transmission to a slave device that was started by the `Wire.beginTransmission()` function.

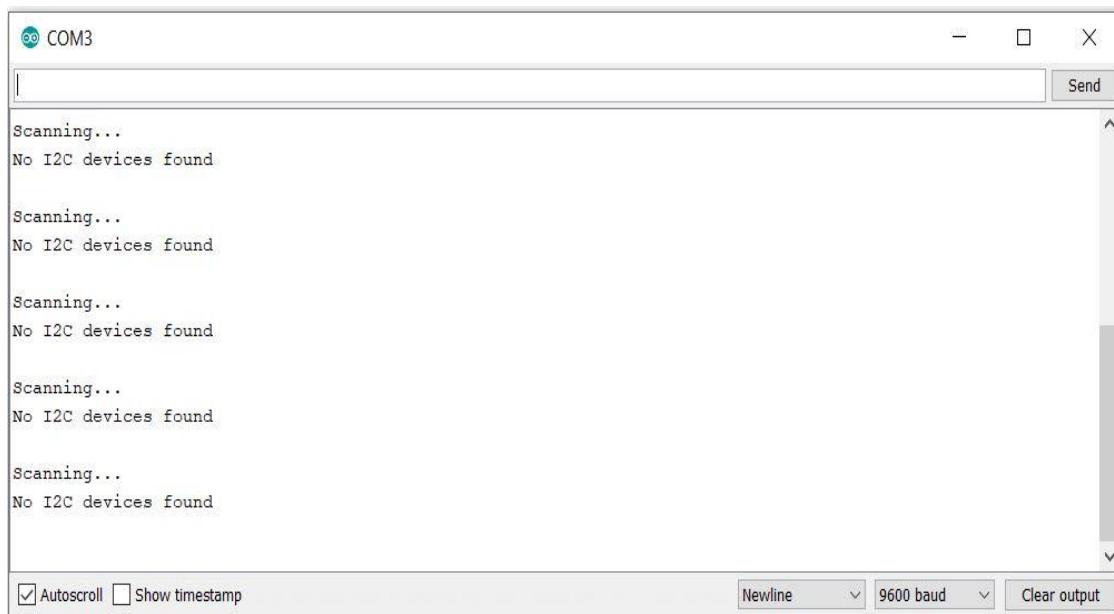


Figure 67: Output of `i2c_scanner` Program

## 6.1.2 Voltage and Breadboard Testing

The voltage of individual components is a key detail to ensure the proper functionality of the system. This section outlays the various voltage testing for the hardware within the system, such as the output voltage from the solar panel, the battery, the voltage regulation between the solar panel and the battery, and various other key components of the system.

Battery voltage is testing is performed to determine the fully charge voltage of the battery this can be used to ensure that the output from the voltage regulation is large enough to ensure proper charging of the battery. This can also be used to test if the solar panel is charging the battery. First measuring the voltage of the battery and then allowing the solar panel to charge the battery, will then allow the tester to remeasure the voltage after charging. If the voltage is higher after charging this displays that the battery actually experienced a charge. Figure 68 displays the initial voltage of the battery when received.



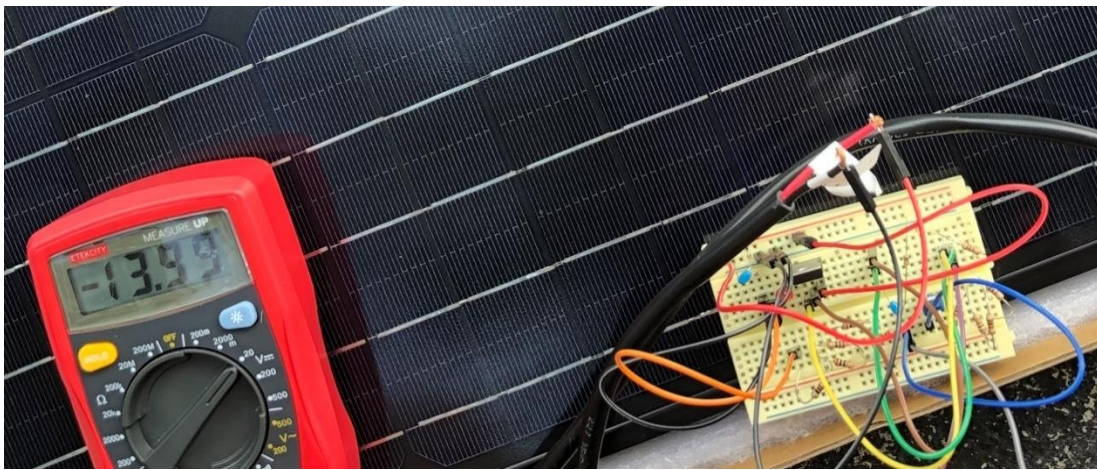
*Figure 68: Voltage Testing of the Battery*

Testing the solar panel to ensure proper voltage output is necessary. While the solar panel is rated as a 12V solar panel, the output of the solar panel is 19.5V, as seen in Figure 69. Through the testing of the voltage seen below, the panel is around the 19.5V range however can be above or below this range. The digital voltmeter displays a negative 19V to show power output by the solar panel.

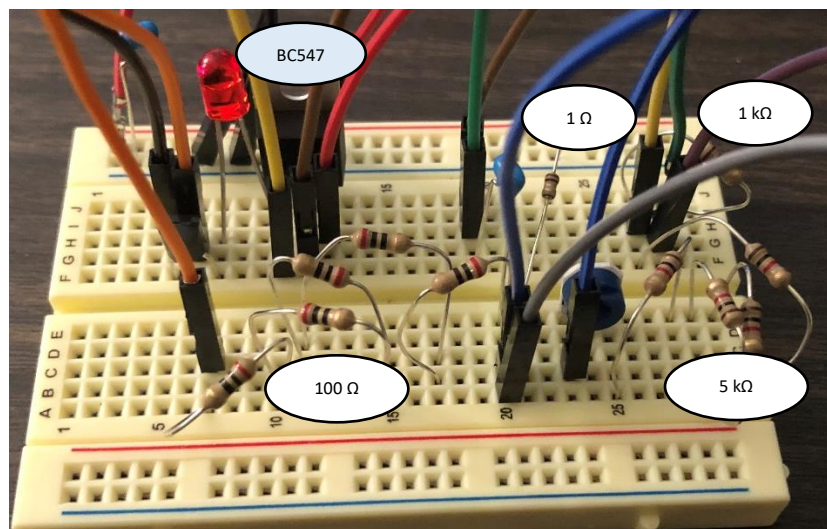


*Figure 69: Solar Panel Voltage Testing*

After testing the circuitry in Figure 71, testing of the voltage regulation schematic from the solar panel to the battery occurred. This testing will ensure the proper voltage for the battery, allowing it to recharge. The Figure 71 shows the voltage regulation circuit that is realized from the design section using the LM317 voltage regulator and the BC547 NPN BJT. The resistors at the end of the circuitry contain a 1kOhm and 4kOhm and 5K ohm potentiometer to ensure proper voltage regulation relationships. The voltage regulator was attached to the solar panel during the same date and time as previous solar panel voltage testing. Figure 70 displays the testing of the full first subsystem, without the battery. The output voltage of the voltage regulator with the input voltage in the 19-19.5V range was 13.99. This is optimal results for a 12V battery which has a charging voltage range from 13.8-14.4V. During testing the LED light within the circuitry did not illuminate, however, this was implemented into testing for further design goals. Further testing will be needed to test and optimize an indication of battery charging.



*Figure 70: Voltage Testing of the Voltage Regulation Output of Solar Input*



*Figure 71: Voltage Regulation from Solar to Battery*

### 6.1.3 Motor Testing

As a result of the current situation, the motors could not be delivered on time for testing. However, we have made plans to test once parts are procured. In order to test the motor, a battery source and a motor controller will be needed. The motor wires will be properly connected to the motor controller with output pins. The motor controller will be connected to the battery source and with the use of a microcontroller, we will control the PWM inputs into the motor. With this setup, we can run basic code to turn the motor on and off as well as run different speeds.

Once the motor's basic operation is ensured, the next step is to test motor torques. We would need to assemble a drive base and connect the motors with wheels. This will allow us to place different weights to test how much weight it can handle and whether it meets our requirements. These two tests will ensure the basic operations of the motor before testing other aspects.

## 6.2 Proposed Schematic Implementation

The system schematic is the backbone of the system. Implementing a schematic for all necessary components of the system is necessary to ensure proper implementation and functionality of the system. The schematic designed in Eagle will be implemented and transferred to a board layout PCB to create the required PCB. The schematic and PCB will implement all necessary components and other certain devices, such as motor control, that can be implemented within the PCB itself. Exterior devices will be implemented as required, such as the HC-SR04 sensor, as the placement of these sensors must be on the outside of the system to ensure proper obstacle avoidance.

The overall schematic will be broken into three sections as seen in Figure 72. The first two sections will be for voltage regulation and motor control, whereas the last section of the schematic will be for all microcontroller components and sensors or other necessities. These schematics will be broken by voltage regulation from the solar panel into the battery, from the battery to the motors, through the L298N H-bridge motor control. This will generate a 5V output that can be inserted into the next part which is the microcontroller and other devices, such as sensors and communications.

The final part of the schematic contains voltage regulation to move 5V into a 3.3V output for certain components that require it such as the WIFI-Module. This section contains connectors to hook up any external sensors such as the HC-SR04 sensors for trash level detection, as well as, object avoidance systems, and the IR sensors for line detection.

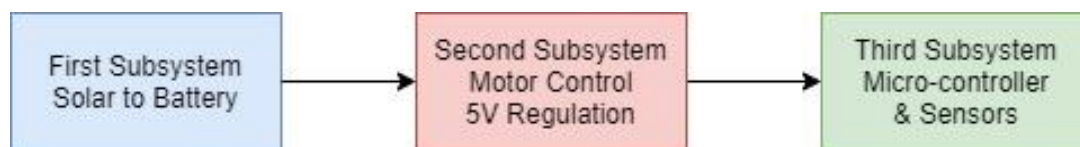


Figure 72: Electrical Schematic into Subsystem

Figure 73: displays the voltage regulation, which is the first part of the schematic. This contains the LM317 voltage regulator to step down the 19.5V from the solar panel to a 13.8-14.4 voltage range for the battery to charge. During testing, the best resistors for the end of the circuit resulted in 1k Ohm and 4k Ohm resistors, respectively for the circuitry, followed by the 5k potentiometer resistor. Once lab access becomes available full testing will be done to ensure proper functionality of the above circuitry. While the voltage of the above circuitry is correct, the battery must charge adequately.

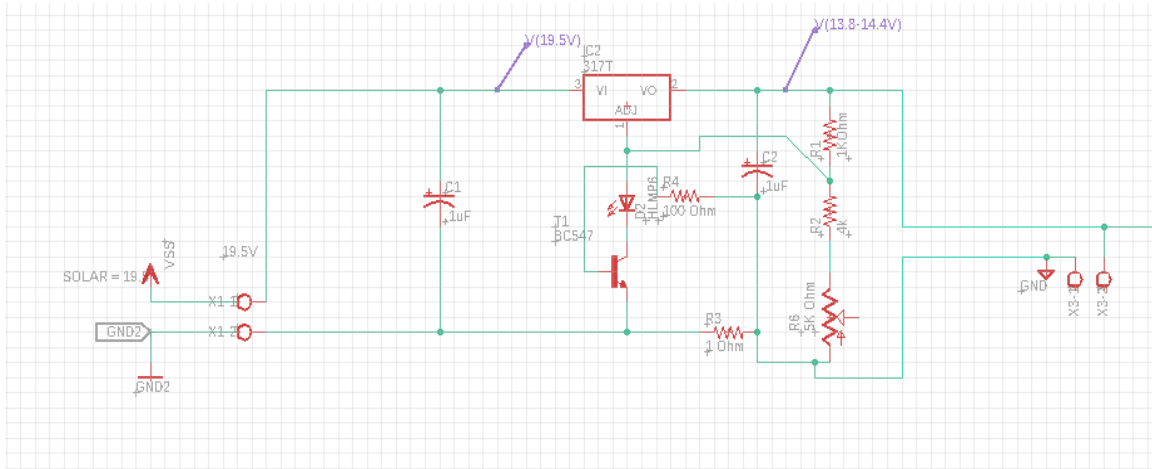


Figure 73: Voltage Regulation Circuitry, Overall Schematic Part 1

The Figure 74 represents the second stage of the schematic. The left part of the above figure connects to the right part of the previous circuitry, Figure 74, which is the voltage regulation schematic. The voltage coming into this section of the circuitry will be around the 12V range. The voltage could be higher or lower dependent upon the battery, rather than it being charging or discharging. This will raise or lower the voltage level respectively. The L298N motor control will act both as a motor control system, as well as a voltage regulation system. From the below circuitry, the voltage is entering the component from the left at 12V; the component uses this voltage to control the motors. The direction of the motors comes from the microcontroller in the L298N input pins. The Vcc of the L298N will display a 5V value. This voltage will be used for to insert into the 3<sup>rd</sup> subsystem of the circuitry.

Therefore, the group has decided to purchase the L298N board itself to implement into the design. Since this component will have no change and can experience a high temperature during motor control, this component causes the schematic to be split into three subsystems. The board is purchased over designing a PCB for this subsystem due to monetary constraints and no change in the L298N circuitry. This also allows the group to buy multiple at a cheap price for testing and accuracy. This will ensure that if one of the motor controls overheats and burns the board that more than one is accessible for continual design and testing. It is easier, more reliable, and cheaper to order an L298N motor control board than to design our own PCB for the motor control and purchase between one and three.

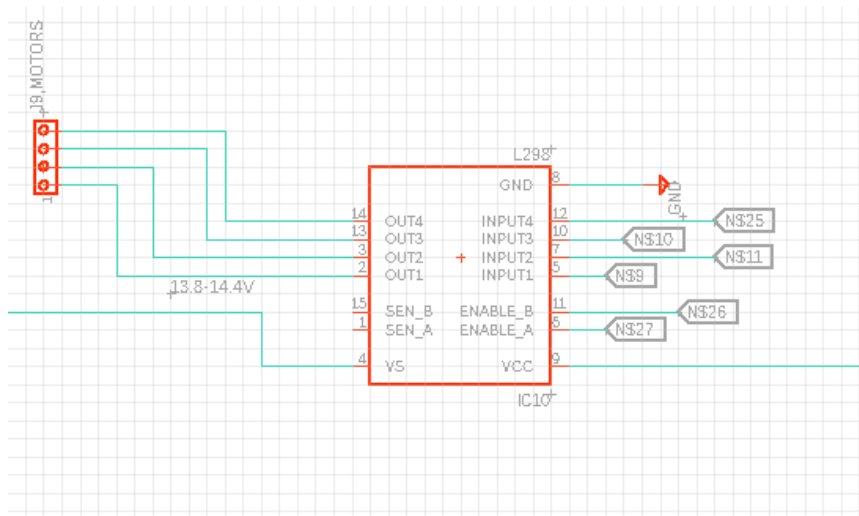


Figure 74: Motor Control, Overall Schematic Part 2

Figure 75 displays the third subsystem of the overall schematic. The output of the second subsystem is the input of the third subsystem. In this subsystem there are two voltages the 5V and the 3.3V which is was stepped down from the 5V. This subsystem also has all the sensor and communication input pins. Each of the output pins are set to be connected to the desired sensors. Therefore, each pin contains the required voltage and ground for the sensor that responds to the pin. The pin connections can be seen in Table 27. Figure 75 displays the third subsystem of the overall circuitry, related to the pinout in Table 27.

Pin Connection	
Assignment	Pin Number
Clock Module SCL	Digital Pin 21 (SCL)PD0
Clock Module SDA	Digital Pin 20 (SDA)PD1
Line Following IR Left Sensor	Analog Pin 8 (ADC8)PK0
Line Following IR Right Sensor	Analog Pin 9 (ADC9)PK1
Wi-Fi Module RXD	Digital Pin 19 (RXD1/INT2)PD2
Wi-Fi Module TXD	Digital Pin 18 (TXD1/INT3)PD3
Motor Control Input 2 (11)	Digital Pin 3 (OC3C/INT5)PE5
Motor Control Input 1 (9)	Digital Pin 2 (OC3B/INT5)PE4
Motor Control Input 4 (25)	Digital Pin 5 (OC3A/INT5)PE3
Motor Control Input 3 (11)	Digital Pin 4 (OCB)PG5
Enable_B (26)	Digital Pin 9 (OC2B)PH6
Enable_A (27)	Digital Pin 8 (OC4C)PH5
HC-SR04 #2 Sensor Trig	Digital Pin 7 (OC4B)PH4
HC-SR04 #2 Sensor Echo	Digital Pin 6 (OC4A)PH3
HC-SR04 #1 Sensor Trig	Digital Pin 12 (OC1B/PCINT6)PB6
HC-SR04 #1 Sensor Echo	Digital Pin 11 (OC1A/PCINT5)PB5
HC-SR04 #3 Sensor Trig	Digital Pin 46 (OC5B)PL4
HC-SR04 #3 Sensor Echo	Digital Pin 45 (OC5A)PL3

Table 27: Pin Connection



## 6.3 Software Testing

Software development is the process of developing software through consecutive phases in an orderly manner. This process includes writing, testing, delivering, and managing projects. To begin with any project, it is important to manage the project so that it meets the requirements. Writing is the basic step of software development and it is the actual writing of the code. Testing in the project is very crucial in order to ensure that the program is fault and bug-free. Testing is the process that undergoes multiple testing techniques such as unit testing, integration testing, and end-to-end testing. Apart from the testing of hardware, it is crucial that software testing is also done in order to ensure that the entire GRAD system is functioning appropriately.

The project includes software not only for the mobile application but also for the functionalities of the microcontroller and its connection with the database by transferring the data or command from the app to the microcontroller. A set of testing of the software will be required throughout the entire software development in order to verify or confirm that every single part of the software involved in this project is functioning properly individually as well as after integrating.

The software test will be conducted in parts through unit testing. Unit testing is a crucial step for all software development. Developers have to test their own code in order to make a bug free code. Unit testing is a software testing method that tests individual units of source code to determine if they are ready and fit for use. It is important as, the testing team and the development can work more together to first design, test and produce a perfect application. Unit testing is small, so it is easier to execute, design and analyze the test results rather than larger code. Unit testing allows the automation of the testing process. Automated testing is the practice of writing code to test our code and then run those tests in an automated fashion. Faults found from the unit test are easy to find and easy to fix or repair. The aim of unit testing is to sort out each part of the program and test that each individual part is working correctly. This composes of checking if the buttons are functioning properly when pressed and that specific button will redirect to the appropriate page and store information.

The second step after unit testing is integration testing. Integration testing is where individual units are combined in order to be tested as a group. It is an extension of unit testing. Hence it takes longer times to execute but confidence in the development is higher than unit testing. The objective of integration testing is to detect bugs or faults that occur between the integrated units. The integration testing will be done by connecting the microcontroller and the mobile application to the database. The motors will have to be observed to ensure that they work on the designated time stored in the database by the user from the mobile application. Also, the connection between the WIFI module, mobile application, and microcontroller will have to be tested to ensure that they are connected.

In addition, to test whether the flow of the application from start to finish is behaving or performing as expected, an end-to-end testing technique is also mandatory. The aim of performing or utilizing the end-to-end testing is to detect the system dependencies and to make sure that the integration between the data is maintained among various systems.



## 7.0 Administrative Material

### 7.1 Project and Finance Discussion

During the beginning of senior design during design idea choosing and implementation, the team decided to implement a project without a sponsor due to the lack of sponsor projects. The team decided to choose a project which would benefit everyone in their daily life. The GRAD system in future might be in a great product where people would want to buy it. Due to the monetary constraints of the members, the budget set for the design was set at \$600 with \$100 for unforeseen circumstances. This totals the overall budget to \$700. The overall budgeting and audit of the project were broken into two tables. The first, Table 28, outlays the project budget, whereas the Table 29 outlays the audit. The audit displays the money spent on each component for the project. These two aspects of the tables can be compared to ensure the project remains within the budget range. The current estimated and rolling budget is displayed in the project budget Table 28 and 29 below:

Project Budget	
<b>Baseline Budget</b>	\$600
<b>Unforeseen Circumstances Budget</b>	\$100
<b>Total Budget</b>	\$700

Table 28: Project Budget

Project Audit					
Part #	Description	Vendor	Unit Price	Units	Total Price
1	Renogy Solar Panel 30W 12V	Renogy	\$56.99	1	\$56.99
2	Wei 12V Battery 20Ah	Amazon	\$36.99	1	\$36.99
3	HC-SR04 Sensors (5 Pack)	Amazon	\$7.99	1	\$7.99
4	19 RPM Econ Spur Gear Motor	ServoCity	\$14.99	2	\$29.98
5	L298N H-Bridge Motor Driver	Amazon	\$6.49	1	\$6.49
6	Arduino Mega 2560	SparkFun	\$38.95	1	\$38.95
7	ESP8266 Wi-Fi Module	Amazon	\$2.71	4	\$10.84
8	HiLetgo DS3231 Real Time Clock Module	Amazon	\$2.30	5	\$11.50
9	OSOYOO IR Obstacle Avoidance Sensors	Amazon	\$0.99	10	\$9.90
10	PCB	OSH Park	\$16.67	3	\$50.00
11	Toter Trash Can	Home Depot	\$59.98	1	\$59.98
<b>Total</b>					\$322.61

Table 29: Project Audit

## 7.2 Project Milestones

Senior design I focuses on research, product comparison and design. Table 30 outlays the timeline as proposed by the group and the research, design and comparisons completed by the group. Implementing this tabled timeline assists in progression of the GRAD system in overall construction and design. The assignment dates and due dates are below to ensure progression of the project including the first draft (60 pages) and the final draft (120+ pages).

Number	Task	Start	End	Status	Responsibility
<b>Senior Design 1</b>					
1	Ideas	1/8/20	1/17/20	Completed	Group B
2	Project Selection & Role Assignment	1/8/20	1/17/20	Completed	Group B
<b>Project Report</b>					
3	Divide & Conquer	1/17/20	1/29/20	Completed	Group B
4	Table of Contents	1/29/20	4/15/20	Completed	Group B
5	First Draft	1/29/20	3/16/20	Completed	Group B
6	Final Draft	1/29/20	4/19/20	Completed	Group B
<b>Research, Documentation &amp; Design</b>					
7	Schematic	2/1/20	2/15/20	Completed	Sean Quinlan
8	GRAD Structure/Packaging	2/1/20	2/15/20	Completed	Abdulsalam Khan
9	Object Avoidance	2/15/20	2/28/20	Completed	Sadiyah Bhuria
10	GRAD Drive system	2/15/20	2/28/20	Completed	Abdulsalam Khan
11	GRAD Detection	2/1/20	2/15/20	Completed	Sadiyah Bhuria
12	Microcontroller	2/15/20	2/28/20	Completed	Heba
13	PCB Design/Layout Research	2/28/20	3/22/20	Completed	Sean Quinlan
14	Path Planning	2/1/20	2/15/20	Completed	Heba
15	Power Supply (Solar Panel & Battery)	2/15/20	2/28/20	Completed	Sean Quinlan
16	App Development	2/28/20	3/22/20	Completed	Sadiyah Bhuria
17	Wifi/Bluetooth for connectivity	2/28/20	3/22/20	Completed	Heba
18	Standards/Other Report Aspects	3/28/20	4/15/20	Completed	Group B
19	Order Parts	4/30/20		Completed	Group B

*Table 30: Senior Design I Project Milestone*

Senior Design II focuses on the implementation of the overall design of the system and ensuring proper functionality of the system including ensuring deliverable functions. The Table 31 outlays the major milestones of Senior Design II and the estimated dates to ensure proper progression throughout the semester. This will ensure proper time management throughout the group and implements a certain milestone to achieve at each point.

Number	Task	Start	End	Status	Responsibility
<b>Senior Design 2</b>					
20	Prototype	8/1/20	9/15/20		Group B
21	Test/Redesign	9/15/20	10/1/20		Group B
22	Final Product	10/1/20	11/15/20		Group B
23	Peer Presentation	TBD	TBD		Group B
24	Final Report	TBD	TBD		Group B
25	Final Presentation	TBD	TBD		Group B

*Table 31: Senior Design II Project Milestone*

These two tables provide the group with an overall design plan. This keeps the team on task, up-to-date, and organized. The GRAD system has many elements and components to go into both the hardware and software at the system. With a group of 4 members, implementing two tables with detailed information such as assignment, due dates, start dates, and detailed task assists all the members in knowing which tasks are assigned to them and when each task should be started and completed. This will ensure no two group members work on the same task and waste time in development and production. The GRAD system has too many elements and moving parts for duplicate work. However, it is recommended that the group still assists and collaborates on all section of the project. This will ensure the best and most efficient results of the system. Since the group consists of computer and electrical engineers, splitting the tasks according to each member's major and track is useful. Assigning tasks for the GRAD project results in a better project if each task assigned to each group member plays to the advantage of the group member. These milestones with assignments are geared towards achieving this goal.

## **7.3 Team Collaboration**

This year because of the spread of the COVID-19, the team could not meet up in person and had to make arrangements to collaborate remotely to get the work done and help reduce the risk of spreading of COVID-19. Team collaboration was achieved by selecting tools that made the team more effective. There are several tools in the industry that offers excellent service. Many factors were taken into account while choosing the best tools that supported mobile platforms and different operating systems. The most crucial part to consider is to choose tools that are easily understandable and simple to use those support deadlines and task management as well. The different tools utilized in this project are discussed in this section.

### **Discord**

Firstly, the team had to choose a platform where they could instantly message, share images and memes. Also, Discord is supported on Android as well as iOS, desktop app, and in-browser messaging. The team chose Discord for several reasons including the above. All the members of the team already had discord on their mobile phones and desktops. Moreover, Discord also has voice and video communication features. The scheduling of meetings was done by messaging on discord. Furthermore, Discord was a great tool utilized by the team in this senior design 1 course and is looking forward to using the same in senior design 2 as well.

### **Google Drive**

Various types of file sharing were made easier by utilizing Google Drive. The team had to refer to other documents to start writing this paper to get a better idea. Both Android and iOS have Google Drive mobile apps that allowed the team to work remotely. The schematics of hardware, flowcharts, and design documents were shared using Google Drive. Also, it was easier to download all the documents from the drive as everyone had their Gmail accounts. For a while, the team utilized Google drive for editing the documents and spreadsheets that allowed the team to work more efficiently in real-time. However, some problems relating to formatting occurred and the team had to use another tool to share the Word document.

### **Zoom**

As stated at the beginning of this section, the team was not able to meet up in person to discuss the paper because of the spread of the COVID 19. Zoom has great features of video calling and screen sharing. The team set up a Zoom meeting where they could talk to each other about their progress and fix issues.

### **Share Point**

SharePoint allowed the team to collaborate on this document. Each team member could open the document and edit it. Every edit being made and saved could be seen by other team members as well.

## 8.0 Conclusion

The team faced and conquered a few challenges during the research, part selection and development of the GRAD system. Initially, the team decided to have tons of features for the GRAD system. However, due to the spread of the COVID-19 this year the team had to discuss and come up with a better plan to reach the goal of the project. The team's main goal is to eliminate the physical demands, incorporate ease, and facilitate efficiency by providing an automated controllable system to schedule trash bin curbside placement. Although this project seemed intimidating at first, it seems more doable after conducting the necessary research and starting to design and test individual components. After building this project, we will gain experience in designing PCBs, robotics, renewable energy, path planning algorithms, and software development for applications.

The GRAD system will be solar-powered while staying environmentally friendly. The GRAD system design also has an app that assists the user to schedule a time for the GRAD to drive itself to the curb. GRAD was designed with user safety in mind- for example, research was conducted on electrical shock standards and battery standards to ensure that GRAD complies with established safety protocols. In addition, the GRAD should be able to successfully detect any obstacle while driving itself to the curb. The parts selected for the design of the GRAD system is discussed in the part selection summary section. This was the most important part of the project as the budget was given by each team member in the group.

The implementation of GRAD will be feasible once all the individual subsystems are working: the power supply, microcontroller, Wi-Fi module, real-time clock, motors, and the app should be individually tested and verified to be working correctly before integrating them into a unified system. Due to current circumstances under COVID-19, we were unable to conduct as much testing as we would have liked since we do not have access to any on-campus labs or other facilities, and therefore no access to equipment such as a power supply, oscilloscope, multimeter, and basic circuit components- however, we were able to perform some tests at home to verify the functionality of the microcontroller, battery, and solar panel.

The individual testing of each part for the GRAD system will allow the team to deliver the goal of the project. The hardware and software design of the GRAD system has been distributed evenly among our team, which consists of three computer engineers and one electrical engineer.

Maintaining clear communication is especially important since our team is unable to meet in person due to stay at home orders enforced in Florida. To stay in touch throughout the design process, our group has met virtually each week through Zoom to ensure that everyone is on track and making progress in writing their pages. We have also been using Discord for general text messaging purposes, Google Drive for large file sharing, and SharePoint to collaboratively write this manuscript. These virtual platforms have made contacting each other easy and has somewhat negated the effects of the social distancing on our project.

## 9.0 References

- [1] Types of solar panels. (2020, January 1). Retrieved March 18, 2020, from <https://www.energysage.com/solar/101/types-solar-panels/>
- [2] Katherine, Agarwal, T., Katherine, Agarwal, T., Agarwal, T., Katherine, ... Agarwal, T. (2019, November 11). Different Types of Voltage Regulator and Working Principle. Retrieved April 12, 2020, from <https://www.elprocus.com/types-of-voltage-regulators-and-working-principle/>
- [3] Simpson, C. (2011). Linear and Switching Voltage Regulator Fundamental Part 1. Retrieved April 12, 2020, from <http://www.ti.com/lit/an/snva558/snva558.pdf>
- [4] Robot Platform: Knowledge: Wheel Control Theory. (n.d.). Retrieved March 20, 2020, from [http://www.robotplatform.com/knowledge/Classification\\_of\\_Robots/wheel\\_control\\_theory.html](http://www.robotplatform.com/knowledge/Classification_of_Robots/wheel_control_theory.html)
- [5] Instructables. (2017, October 2). Complete Motor Guide for Robotics. Retrieved March 30, 2020, from <https://www.instructables.com/id/Complete-Motor-Guide-for-Robotics/>
- [6] (n.d.). Retrieved from <http://www.e-jpc.com/blog/?p=171>
- [7] *Diagram.* (n.d.). Retrieved from <http://www.etonm.com/support/i=33&comContentId=33.html>
- [8] Best Wheeled Trash Cans: Choosing the Right Trash Can For You. (2020, January 9). Retrieved March 3, 2020, from <https://unclefredsfarm.com/best-wheeled-trash-cans/>
- [9] *Blue Hawk 32-Gallon Black Plastic Wheeled Trash Can with Lid.* (n.d.). photograph. Retrieved from <https://www.lowes.com/pd/Blue-Hawk-32-Gallon-Black-Plastic-Wheeled-Trash-Can-with-Lid/1001429702>
- [10] *32 Gal. Greenstone Trash Can with Wheels and Attached Lid.* (n.d.). photograph. Retrieved from <https://www.homedepot.com/p/Toter-32-Gal-Greenstone-Trash-Can-with-Wheels-and-Attached-Lid-79232-R2968/202893770>
- [11] *Rubbermaid Commercial Products Brute Rollout Trash/Garbage Can with Caster Wheels, 32-gallon, Blue (1971949).* (n.d.). photograph. Retrieved from <https://www.amazon.com/dp/B01N5D99W8?creativeASIN=B079TZMD4V&imprToken=iYmoS4HuydAnOdSOV7Ms3Q&slotNum=31&tag=unclefreds-20&linkCode=ogi&th=1>
- [12] Zender, L., & Sebalo, S. (n.d.). *Counting Your Community's Trash.* Zender Environmental Services.
- [13] *Arrangement of the brushless Dc motor.* (n.d.). Retrieved from <http://www.cyberphysics.co.uk>
- [14] PCB Basics. (n.d.). Retrieved March 18, 2020, from <https://learn.sparkfun.com/tutorials/pcb-basics/all>

- [15] Full Wave Rectifier and Bridge Rectifier Theory. (2020, March 31). Retrieved April 9, 2020, from [https://www.electronics-tutorials.ws/diode/diode\\_6.html?nab=1](https://www.electronics-tutorials.ws/diode/diode_6.html?nab=1)
- [16] Cook, D. (n.d.). Simple Solar Power Circuit with Rechargeable Battery Backup. Retrieved April 9, 2020, from <https://www.robotroom.com/Solar-Recharging.html>
- [17] Schaffer, S. (2020, March 6). Types of Battery Systems for Robots: Custom. Retrieved from <https://maker.pro/custom/tutorial/battery-systems-for-robots>
- [18] Solar Photovoltaic Cell Basics. (n.d.). Retrieved from <https://www.energy.gov/eere/solar/articles/solar-photovoltaic-cell-basics>
- [19] PVWatts. (n.d.). Retrieved from <https://pvwatts.nrel.gov/>
- [20] Raspberry Pi 4 Model B specifications – Raspberry Pi. (n.d.). Retrieved February 24, 2020, from <https://www.raspberrypi.org/products/raspberry-pi-4-model-b/specifications/>
- [21] Jetson Nano Developer Kit. (2020, February 21). Retrieved February 24, 2020, from <https://developer.nvidia.com/embedded/jetson-nano-developer-kit>
- [22] ODROID-XU4. (n.d.). Retrieved February 24, 2020, from <https://www.hardkernel.com/shop/odroid-xu4-special-price/>
- [23] “Arduino Mega 2560 Rev3.” Arduino Mega 2560 Rev3 | Arduino Official Store, Arduino, [store.arduino.cc/usa/mega-2560-r3](https://store.arduino.cc/usa/mega-2560-r3).
- [24] “MSP430FR6989 .” Texas Instruments, Texas Instruments, [www.ti.com/product/MSP430FR6989](https://www.ti.com/product/MSP430FR6989).
- [25] “The Internet of Things with ESP32.” The Internet of Things with ESP32, ESP32net, [esp32.net/](https://esp32.net/).
- [26] Littler, Neil, and Stephanie Littler. “The IRobot® Create®2 - Raspberry Pi - Camera - Web Interface Project .” [Https://Www.irobotweb.com/](https://www.irobotweb.com/).
- [27] “IRobot Create® 2 Programmable Robot.” IRobot, IRobot, [store.irobot.com/default/create-programmable-programmable-robot-irobot-create-2/RC65099.html](https://store.irobot.com/default/create-programmable-programmable-robot-irobot-create-2/RC65099.html).
- [28] “List of WLAN Channels.” *Wikipedia*, Wikimedia Foundation, 16 Mar. 2020, [en.wikipedia.org/wiki/List\\_of\\_WLAN\\_channels](https://en.wikipedia.org/wiki/List_of_WLAN_channels).
- [29] Wilson, Tracy V., et al. “How WiFi Works.” *HowStuffWorks*, HowStuffWorks, 30 Apr. 2001, [computer.howstuffworks.com/wireless-network3.htm](https://computer.howstuffworks.com/wireless-network3.htm).
- [30] DeLisle, Jean-Jacques. “What’s the Difference Between IEEE 802.11af and 802.11ah?” *Microwave&RF*, Endeavor Business Media, LLC, [www.mwrf.com/technologies/active-components/article/21846205/whats-the-difference-between-ieee-80211af-and-80211ah](https://www.mwrf.com/technologies/active-components/article/21846205/whats-the-difference-between-ieee-80211af-and-80211ah).

- [31] Hoffman, Chris. “Wi-Fi Security: Should You Use WPA2-AES, WPA2-TKIP, or Both?” *How, How-To Geek*, 21 July 2017, [www.howtogeek.com/204697/wi-fi-security-should-you-use-wpa2-aes-wpa2-tkip-or-both/](http://www.howtogeek.com/204697/wi-fi-security-should-you-use-wpa2-aes-wpa2-tkip-or-both/).
- [32] “802.11 Association Process Explained.” *Cisco Meraki*, Cisco, 26 Mar. 2019, [documentation.meraki.com/MR/WiFi\\_Basics\\_and\\_Best\\_Practices/802.11\\_Association\\_Process\\_Explained](https://documentation.meraki.com/MR/WiFi_Basics_and_Best_Practices/802.11_Association_Process_Explained).
- [33] Chaouchi, Hakima, and Maryline Laurent-Maknavicius. *Wireless and Mobile Network Security: Security Basics, Security in on-the-Shelf and Emerging Technologies*. ISTE, 2009.
- [34] R. Michael Rogers. “WiFi Module - ESP8266.” WRL-13678 - SparkFun Electronics, SparkFun Electronics, [www.sparkfun.com/products/13678](http://www.sparkfun.com/products/13678).
- [35] “ESP8266 Module (WRL-13678).” Sparkfun Electronics.
- [36] “CC3120 SimpleLink™ Wi-Fi® Wireless Network Processor, Internet-of-Things Solution for MCU Applications.” Texas Instruments, Feb. 2017.
- [37] “Geekworm NVIDIA Jetson Nano Dual Band Wireless USB 3.0 WiFi Adapter 5GHz+2.4GHz 1200M.” *Geekworm*, Geekworm, [geekworm.com/products/geekworm-nvidia-jetson-nano-dual-band-wireless-usb-3-0-adapter-5ghz-2-4ghz-1200m](http://geekworm.com/products/geekworm-nvidia-jetson-nano-dual-band-wireless-usb-3-0-adapter-5ghz-2-4ghz-1200m).
- [38] Kramer, Steven. “Understanding Bluetooth Range.” *Bluetooth® Technology Website*, Bluetooth, [www.bluetooth.com/learn-about-bluetooth/bluetooth-technology/range/](http://www.bluetooth.com/learn-about-bluetooth/bluetooth-technology/range/).
- [39] “Bluetooth Adaptive Frequency Hopping on a R&S CMW .” Rohde & Schwarz.
- [40] Franklin, Curt, and Chris Pollette. “How Bluetooth Works.” *HowStuffWorks*, HowStuffWorks, 11 Nov. 2019, [electronics.howstuffworks.com/bluetooth2.htm](http://electronics.howstuffworks.com/bluetooth2.htm).
- [41] Padgette, John & Bahr, John & Batra, Mayank & Holtmann, Marcel & Smithbey, Rhonda & Chen, Lily & Scarfone, Karen. (2017). NIST Special Publication 800-121 Revision 2, Guide to Bluetooth Security. 10.6028/NIST.SP.800-121r2.
- [42] “What Are Standard Driveway Lengths and Widths?” *What Are Standard Driveway Lengths and Widths?*, Ask Media Group, LLC, [www.reference.com/world-view/standard-driveway-lengths-widths-6cff697bf6814959](http://www.reference.com/world-view/standard-driveway-lengths-widths-6cff697bf6814959).
- [43] “Bluetooth - Protocol .” *ShareTechnote*, [www.sharetechnote.com/html/Bluetooth\\_Protocol.html](http://www.sharetechnote.com/html/Bluetooth_Protocol.html).
- [44] “Bluetooth Network Connection & Pairing.” *Electronics Notes*, [www.electronics-notes.com/articles/connectivity/bluetooth/network-pairing-connection.php](http://www.electronics-notes.com/articles/connectivity/bluetooth/network-pairing-connection.php).



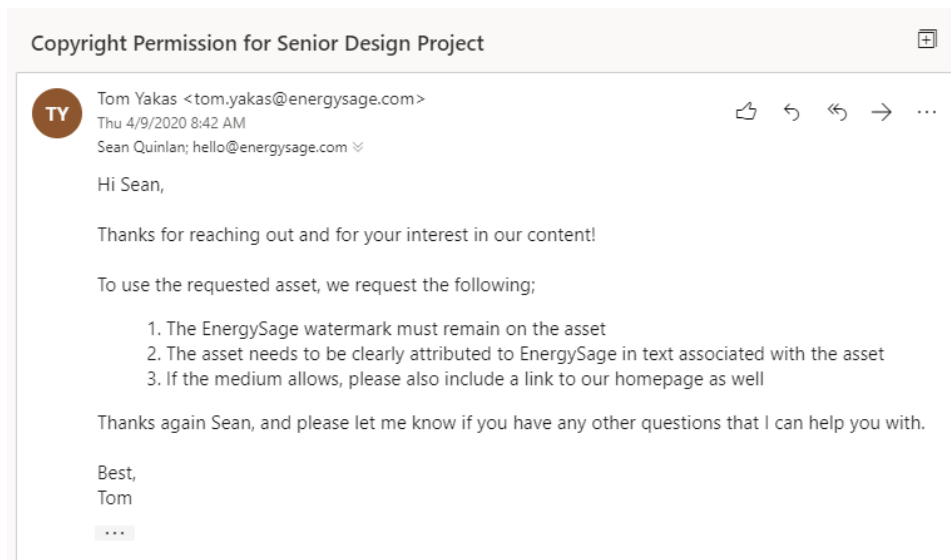
- [45] “Bluetooth Basics .” Paul G. Allen School of Computer Science & Engineering, University of Washington.
- [46] “Path Planning.” *Path Planning - an Overview | ScienceDirect Topics*, ScienceDirect, [www.sciencedirect.com/topics/engineering/path-planning](http://www.sciencedirect.com/topics/engineering/path-planning).
- [47] Stentz, Anthony. “Optimal and Efficient Path Planning for Partially-Known Environments.” Carnegie Mellon University.
- [48] Saddam. “Line Follower Robot Using Arduino.” *CircuitDigest*, CircuitDigest, 18 June 2015, [circuitdigest.com/microcontroller-projects/line-follower-robot-using-arduino](http://circuitdigest.com/microcontroller-projects/line-follower-robot-using-arduino).
- [49] Sanjeev, Arvind. “How to Make a Line Follower Robot in 10 Minutes: Arduino.” *Maker Pro*, Maker Pro, 17 Apr. 2020, [maker.pro/arduino/projects/make-line-follower-robot](http://maker.pro/arduino/projects/make-line-follower-robot).
- [50] “Types of Sensors for Target Detection and Tracking.” *Into Robotics*, 20 Nov. 2013, [www.intorobotics.com/types-sensors-target-detection-tracking/](http://www.intorobotics.com/types-sensors-target-detection-tracking/).
- [51] RF Wireless World. (n.d.). Retrieved March 11, 2020, from <https://www.rfwireless-world.com/Terminology/Advantages-and-Disadvantages-of-Infrared-Sensor.html>
- [52] LIDAR vs RADAR Comparison. Which System is Better for Automotive? (2019, August 21). Retrieved March 11, 2020, from <https://archer-soft.com/en/blog/lidar-vs-radar-comparison-which-system-better-automotive>
- [53] “Ultrasonic Sensor Working Applications and Advantages.” *Microcontrollers Lab*, 30 May 2017, [microcontrollerslab.com/ultrasonic-sensor-working-applications-advantages/](http://microcontrollerslab.com/ultrasonic-sensor-working-applications-advantages/).
- [54] “RF Wireless World.” *RF Wireless Vendors and Resources | RF Wireless World*, [www.rfwireless-world.com/Terminology/Ultrasonic-vs-Infrared.html](http://www.rfwireless-world.com/Terminology/Ultrasonic-vs-Infrared.html)
- [55] Camera Module. (n.d.). Retrieved March 13, 2020, from <https://www.raspberrypi.org/documentation/hardware/camera/>
- [56] Miller, J. (2019, May 9). Setting up the Pi NoIR Camera with Raspberry Pi : Raspberry Pi. Retrieved March 15, 2020, from <https://maker.pro/raspberry-pi/tutorial/how-to-interface-pi-noir-v2-camera-with-raspberry-pi>
- [57] Raspberry Pi NoIR Camera Module V2. (n.d.). Retrieved March 15, 2020, from <https://www.pishop.us/product/raspberry-pi-noir-camera-module-v2/?src=raspberrypi>
- [58] pixycam (Ed.). (2019, February 18). Documentation. Retrieved March 16, 2020, from <https://docs.pixycam.com/wiki/doku.php?id=wiki:v2:overview>
- [59] SparkFun Electronics. (n.d.). Pixy2 CMUcam5. Retrieved March 16, 2020, from <https://www.sparkfun.com/products/14678>



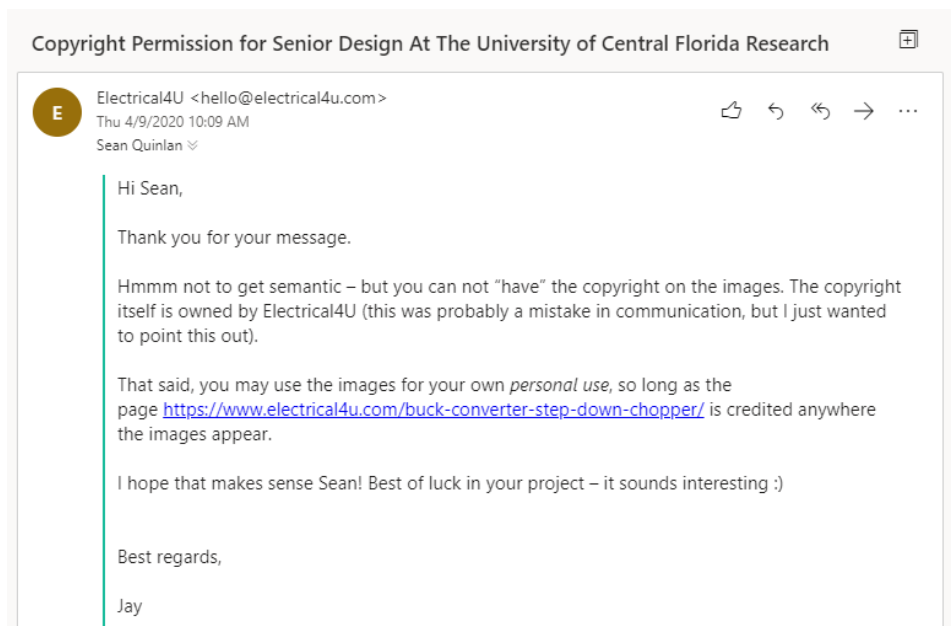
- [74] Progress Software. (n.d.). Native mobile apps with Angular, Vue.js, TypeScript, JavaScript - NativeScript. Retrieved April 3, 2020, from <https://www.nativescript.org/>
- [75] Patel, R. (2019, April 16). NativeScript V/s React Native: What To Choose For Cross-Platform App Development. Retrieved April 3, 2020, from <https://dev.to/ronakpatel70/nativescript-v-s-react-native-what-to-choose-for-cross-platform-app-development-d20>
- [76] Beal, Vangie. "802.11 IEEE Wireless LAN Standards." What Is 802.11 Wireless LAN Standards? Webopedia Definition, Webopedia, [www.webopedia.com/TERM/8/802\\_11.html](http://www.webopedia.com/TERM/8/802_11.html).
- [77] Generic Standard on Printed Board Design. (1998, February). Retrieved March 31, 2020, from <http://www.ipc.org/TOC/IPC-2221.pdf>
- [78] Iantosca, L., Radcliff, katy, & BEST Inc. (2020, March 11). IPC-6012 or IPC-A-600: Which Standard Should You Use? Retrieved March 31, 2020, from <https://www.protoexpress.com/blog/ipc-6012-ipc-600-standard-use/>
- [79] Guide to IPC Standards for PCBs. (2020, March 13). Retrieved March 31, 2020, from <https://www.mclpcb.com/ipc-standards-for-pcbs/>
- [80] Develop, test and integrate batteries according to the standards. (n.d.). Retrieved March 31, 2020, from <https://www.batterystandards.info/node/1046>
- [81] Kelechava, B. (2019, July 8). ANSI C18.2M: Portable Rechargeable Cell and Batteries - Specifications and Safety - ANSI Blog. Retrieved March 31, 2020, from <https://blog.ansi.org/2017/10/ansi-c182m-portable-rechargeable-cell-batteries/#gref>
- [82] IEEE SCC21 Photovoltaic Standards. (n.d.). Retrieved March 31, 2020, from [http://grouper.ieee.org/groups/scc21/pv\\_series/1562.html](http://grouper.ieee.org/groups/scc21/pv_series/1562.html)
- [83] Brunner, C. U., Evans, C., & Werle, R. (2014, February 11). PDF.
- [84] POWER SUPPLY SAFETY STANDARDS, AGENCIES, AND MARKS. (n.d.). Retrieved March 31, 2020, from <https://www.cui.com/catalog/resource/power-supply-safety-standards-agencies-and-marks.pdf>
- [85] Electric motors. (n.d.). Retrieved April 15, 2020, from [https://www.iec.ch/perspectives/government/sectors/electric\\_motors.htm](https://www.iec.ch/perspectives/government/sectors/electric_motors.htm)
- [86] Importance of Code Quality and Coding Standard in Software Development. (2020, March 06). Retrieved April 16, 2020, from <https://www.multidots.com/importance-of-code-quality-and-coding-standard-in-software-development/>
- [87] Kumar, S. (2019, July 02). Coding Standards and Guidelines. Retrieved April 16, 2020, from <https://www.geeksforgeeks.org/coding-standards-and-guidelines/>

- [88] Advanced Circuits. (n.d.). Retrieved March 19, 2020, from <https://www.4pcb.com/trace-width-calculator.html>
- [89] “DS3231 Extremely Accurate I2C-Integrated RTC/TCXO/Crystal.” Maxim Integrated.
- [90] Dejan. “Arduino and DS3231 Real Time Clock Tutorial.” *HowToMechatronics*, HowToMechatronics, 15 Dec. 2019, [howtomechatronics.com/tutorials/arduino/arduino-ds3231-real-time-clock-tutorial](http://howtomechatronics.com/tutorials/arduino/arduino-ds3231-real-time-clock-tutorial).
- [91] “Library: DS3231.” *Rinky-Dink Electronics*, [www.rinkydinkelectronics.com/library.php?id=73](http://www.rinkydinkelectronics.com/library.php?id=73).
- [92] “AttachInterrupt()” *Arduino Reference*, [www.arduino.cc/reference/en/language/functions/external-interrupts/attachinterrupt/](http://www.arduino.cc/reference/en/language/functions/external-interrupts/attachinterrupt/).
- [93] YasithLokuge. “Connecting ESP8266-01 to Arduino UNO/MEGA and BLYNK.” *Arduino Project Hub*, [create.arduino.cc/projecthub/user720003162/connecting-esp8266-01-to-arduino-uno-mega-and-blynk-194f17](http://create.arduino.cc/projecthub/user720003162/connecting-esp8266-01-to-arduino-uno-mega-and-blynk-194f17).
- [94] “How to Build a Robot - Line Follower - Projects.” *All About Circuits*, [www.allaboutcircuits.com/projects/how-to-build-a-robot-line-follower/](http://www.allaboutcircuits.com/projects/how-to-build-a-robot-line-follower/).
- [95] Lokuge, Yasith. “Complete Guide to Design a Basic Line Follower Robot.” *Medium*, Towards Data Science, 12 Apr. 2020, [towardsdatascience.com/complete-guide-to-design-a-basic-line-follower-robot-318365c00bd1](https://towardsdatascience.com/complete-guide-to-design-a-basic-line-follower-robot-318365c00bd1). [52] LIDAR vs RADAR Comparison. Which System is Better for Automotive? (2019, August 21). Retrieved March 11, 2020, from <https://archer-soft.com/en/blog/lidar-vs-radar-comparison-which-system-better-automotive>
- [96] Intel® RealSense Depth Camera (D415). (n.d.). Retrieved April 18, 2020, from <https://www.sparkfun.com/products/14946>
- [97] Electronics Fundamentals: Voltage Regulator. (n.d.). Retrieved from <https://www.jameco.com/Jameco/workshop/learning-center/voltage-regulator.html>
- [98] Marion, B, et al. “Performance Parameters for Grid-Connected PV Systems.” *NREL.gov*, 2005, [www.nrel.gov/docs/fy05osti/37358.pdf](http://www.nrel.gov/docs/fy05osti/37358.pdf).

## Appendix: Copyright Permissions



*Figure 76: EnergySage Image Copyright Permission*



*Figure 77: Electrical4U Image Copyright Permission*

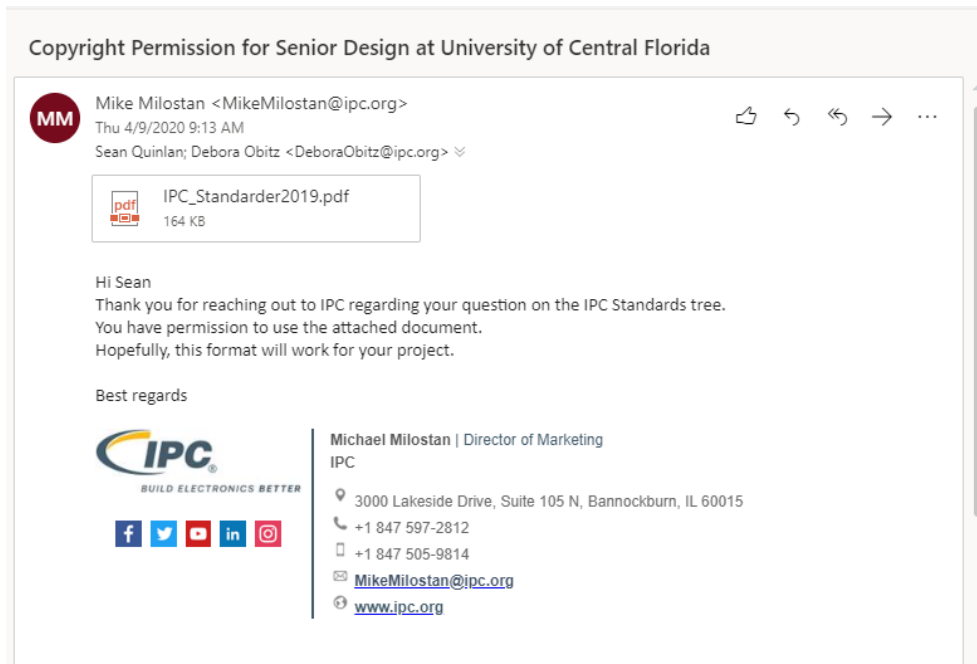


Figure 78: IPC Image Copyright Permission

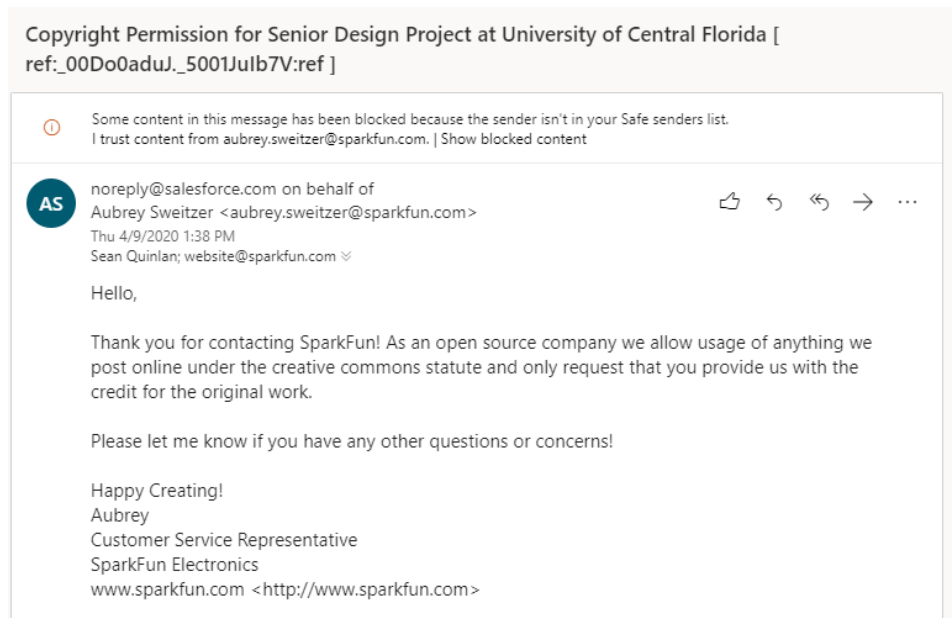
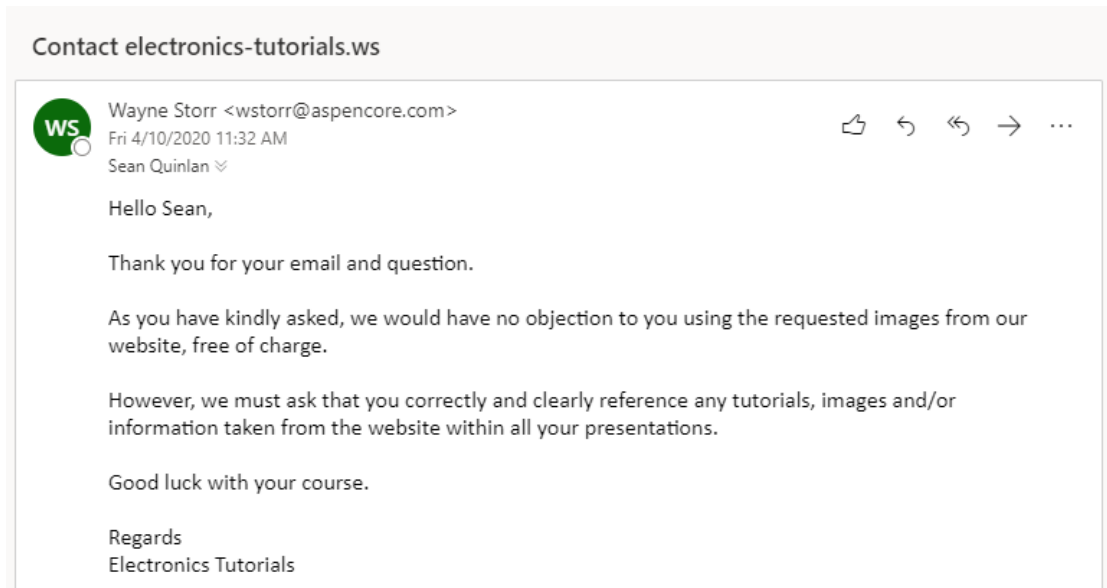
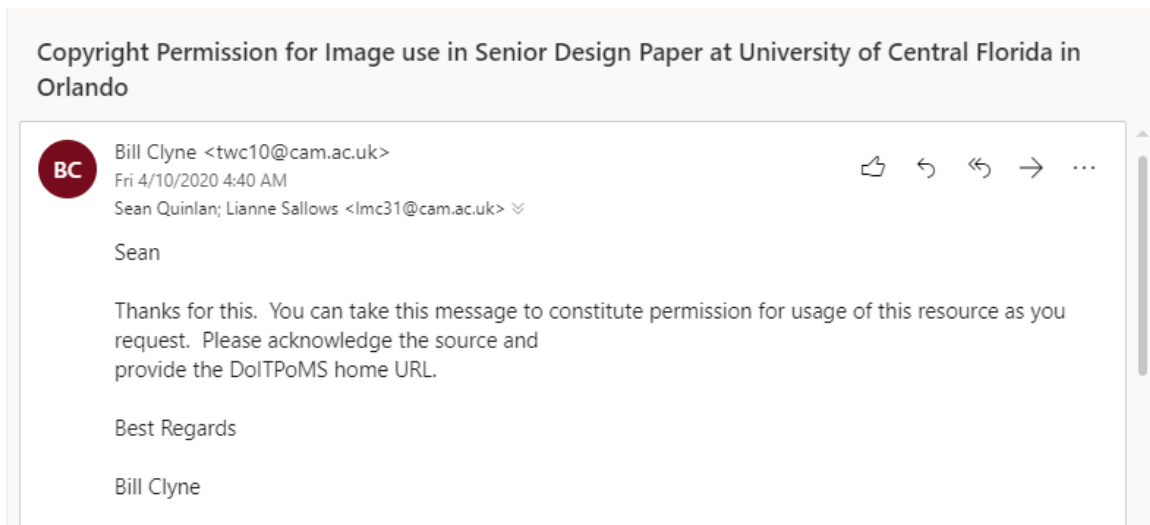


Figure 79: Sparkfun Image Copyright Permission



*Figure 80: Electronic Tutorials Copyright Permission*



*Figure 81: DoITPoMS Image Copyright Permission*

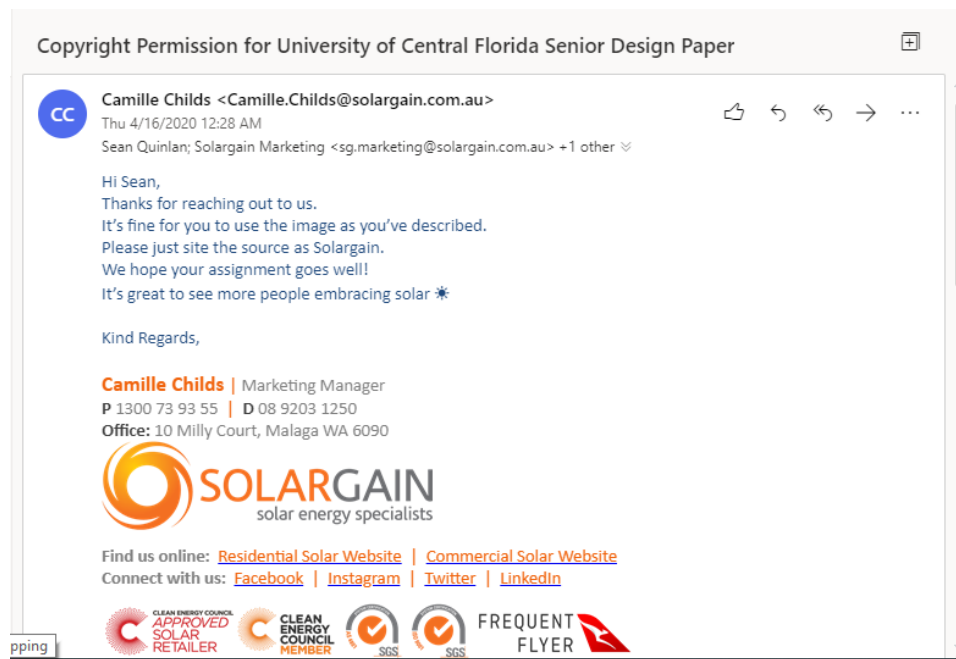


Figure 82: Solar Gain Copyright Permission

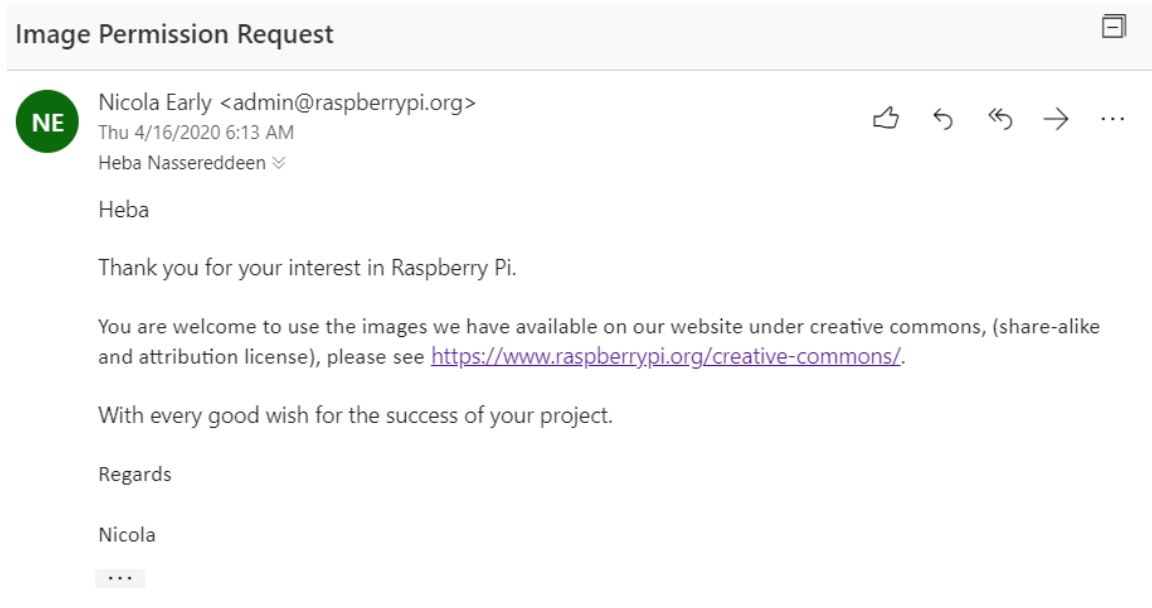


Figure 83: Raspberry PI Image Copyright Permission



## Arduino Logo & Trademarks

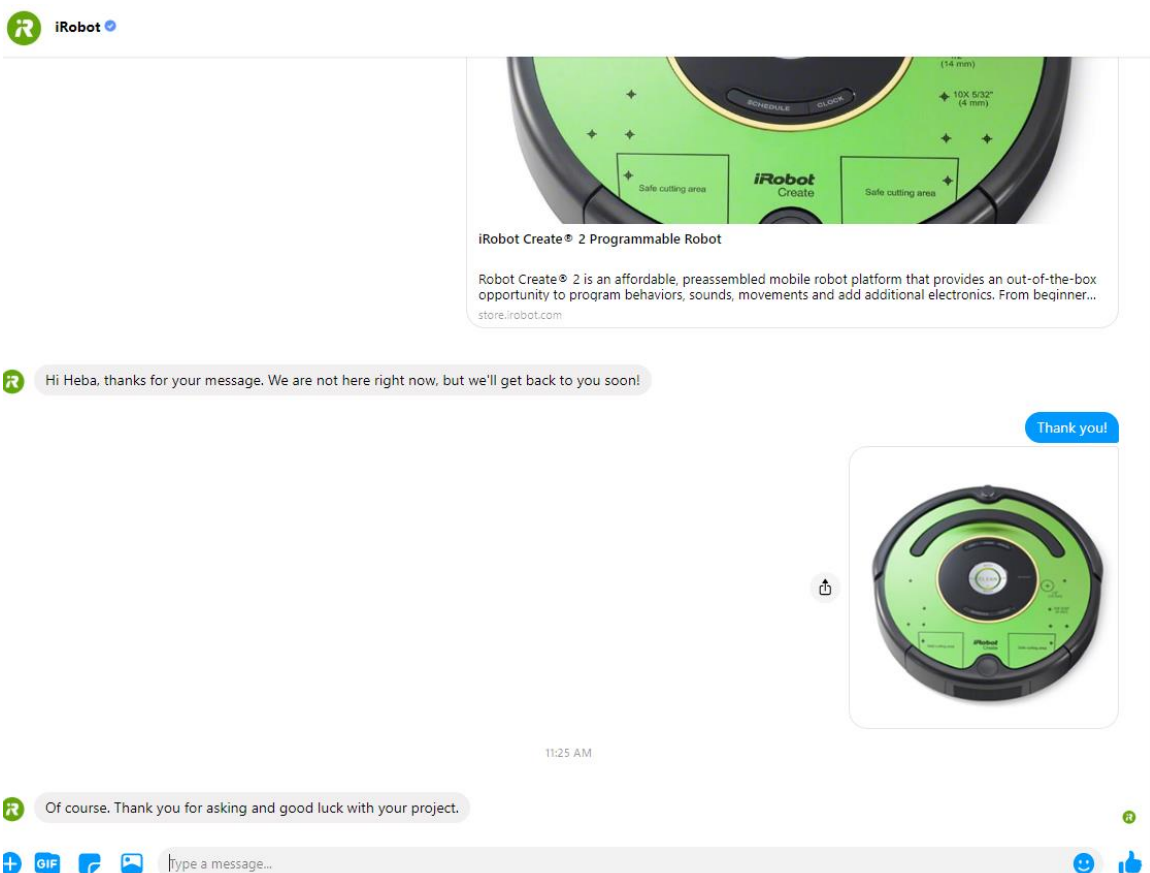
Can I use the Arduino logo to identify non commercial content?

If you're creating tutorials, managing a local community of Arduino users, opening up an Arduino-focused page online (ie. social networks) you can use the [Arduino Community Logo](#)! This will allow people identify better what comes directly from us, and what comes from the community.

I want to design my own board, what should I do?

The reference designs for the Arduino boards are available from their specific product pages. They're licensed under a [Creative Commons Attribution Share-Alike license](#), so you are free to use and adapt them for your own needs without asking permission or paying a fee. If you're looking to make something of interest to the community, we'd encourage you to discuss your ideas on the [hardware development forum](#) so that potential users can offer suggestions.

*Figure 84: Arduino Copyright Permission*



*Figure 85: iRobot Copyright Permissions*

## Image Permission Request



Bill Wong <bwong@endeavorb2b.com>  
Thu 4/16/2020 3:41 PM  
Heba Nasserdedeen ✓

Yes. Please indicate the it is provided by Endeavor Media/Microwaves&RF.

-Bill Wong

William Wong  
Senior Content Director  
Editor/Electronic Design  
Electronic Design, Microwaves&RF, Evaluation Engineering  
Endeavor Business Media

1333 Moon Drive  
Yardley, PA 19067  
T: +1 215-736-2449  
M: +1 267-575-7701  
[bwong@endeavorb2b.com](mailto:bwong@endeavorb2b.com)

...

Are the suggestions above helpful? Yes No

*Figure 86: Endeavor Media/Microwaves&RF Image Copyright Permission*

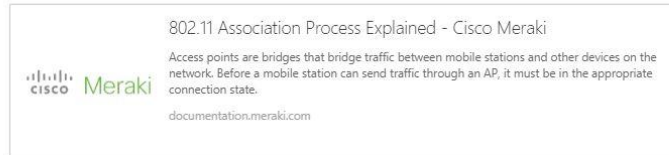
## Image Permission Request



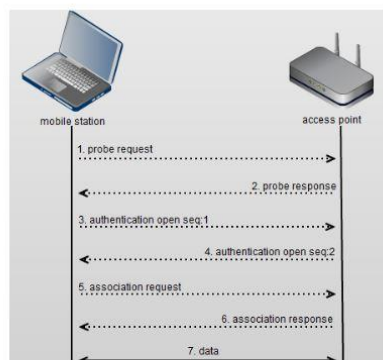
Heba Nasserdedeen  
Thu 4/16/2020 3:05 AM  
[support@meraki.com](mailto:support@meraki.com) ✓

Hello,

I am a student at the University of Central Florida working on a Senior Design Capstone Project. I wanted to request permission to use an image from your page at [https://documentation.meraki.com/MR/WiFi\\_Basics\\_and\\_Best\\_Practices/802.11\\_Association\\_Process\\_Explained](https://documentation.meraki.com/MR/WiFi_Basics_and_Best_Practices/802.11_Association_Process_Explained)



for our research paper. The image is copied below.



Thank you,  
Heba Nasserdedeen

*Figure 87: Cisco Meraki Image Permission*

TI Home > Copyright

## Copyrights

Texas Instruments is pleased to provide the information on these pages of the World Wide Web. We encourage you to read and use this information in developing new products.

TI grants permission to download, print copies, store downloaded files on a computer and reference this information in your documents only for your personal and non-commercial use. But remember, TI retains its copyright in all of this information. This means that you may not further display, reproduce, or distribute this information without permission from Texas Instruments. This also means you may not, without our permission, "mirror" this information on your own server, or modify or re-use this information on another system.

TI further grants permission to non-profit, educational institutions (specifically K-12, universities and community colleges) to download, reproduce, display and distribute the information on these pages solely for use in the classroom. This permission is conditioned on not modifying the information, retaining all copyright notices and including on all reproduced information the following credit line: "Courtesy of Texas Instruments". Please send us a note describing your use of this information under the permission granted in this paragraph. Send the note and describe the use according to the request for permission explained below.

*Figure 88: Texas Instruments Copyright Permission*

### Re: Image Permission Request



cindy@geekworm.com  
Thu 4/16/2020 5:26 AM  
Heba Nasserreddeen; shopify <sp@geekworm.com> ▾

Hello friend,  
Thanks for your email.  
Yes, of course you can use the photo for research paper, it is ok to use just not for sale.  
Also we are glad that you can introduce our product.  
Best regards,  
Cindy/Geekworm

---

**Cindy Ding**  
Shenzhen Tongban Technology Co., Ltd.  
m: 0086 18565727529  
w: [geekworm.com](http://geekworm.com) e: [cindy@geekworm.com](mailto:cindy@geekworm.com)

...

Are the suggestions above helpful? Yes No

*Figure 89: Geekwork Image Copyright Permission*

Image Permission Request



Heba Nasserdeedeen  
Thu 4/16/2020 3:47 AM  
Info@rsa.rohde-schwarz.com

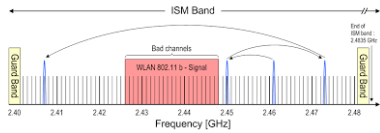


Hello,

I am a student at the University of Central Florida working on a Senior Design Capstone Project. I wanted to request permission to use an image from your document at [https://scdn.rohde-schwarz.com/ur/pws/dl\\_downloads/dl\\_application/application\\_notes/1c108/1C108\\_0e\\_Bluetooth\\_BR\\_EDR\\_AFH.pdf](https://scdn.rohde-schwarz.com/ur/pws/dl_downloads/dl_application/application_notes/1c108/1C108_0e_Bluetooth_BR_EDR_AFH.pdf) for our research paper. The image is copied below:

Hopping on a R&S CMW Application Note

Basic Ideas 1C108\_0e Rohde & Schwarz Bluetooth Adaptive Frequency Hopping on a R&S CMW 7 2.1.2 Channel Map  
The channel map is provided by the master and contains the relevant information about the 79 frequency channels of the piconet:  
scdn.rohde-schwarz.com



Thank you,

Heba Nasserdeedeen

Figure 90: Rohde & Schwarz Copyright Permission

Image Permission Use

Flag for follow up.



Jaeku Ryu <jaekuryu@gmail.com>  
Thu 4/16/2020 9:45 AM  
Heba Nasserdeedeen

Hello Heba

Sure... you can use the diagram.  
thank you for asking.  
Good Luck !

Best Regards

Jaeku

...

Thank you so much! I really appreciate it! Great, thank you so much! Thank you so much! I appreciate it!

Are the suggestions above helpful? Yes No



Heba Nasserdeedeen  
Thu 4/16/2020 3:54 AM  
jaekuryu@gmail.com

Hello,

I am a student at the University of Central Florida working on a Senior Design Capstone Project. I wanted to request permission to use an image from your page at [http://www.sharetechnote.com/html/Bluetooth\\_Protocol.html](http://www.sharetechnote.com/html/Bluetooth_Protocol.html) for our research paper. The image is copied below:

ShareTechnote

Bluetooth - Protocol Home : www.sharetechnote.com. Overall State Transition . Overall state flow of bluetooth communication is as follows. When you see this kind of circular state diagram, you'd better select one of the starting point and end point.  
www.sharetechnote.com

Figure 91: ShareTechnote Image Permission

## Image Permission Request



Circuit Digest <contact@circuitdigest.com>

Thu 4/16/2020 4:27 AM

Heba Nasserreddeen

Dear Heba, yes you can use the image for your research paper.

...

Okay, thank you!

Great, thank you so much!

Ok, thank you very much.

Thanks for your feedback. It will help us improve Outlook.

Figure 92: Circuit Digest Copyright Permission

Copyright Permission Senior Design Project at University of Central Florida

Sean Quinlan  
Wed 4/15/2020 9:19 PM  
team@elprocus.com

Hello EL-PRO-CUS,

I am an undergraduate student at The University of Central Florida, designing a automated garbage can for my Senior Design Class. I am implementing voltage regulators into the project and would like copyright permission to use pictures on your website. I would like to have copyright for all of the pictures on "Different Types of Voltage Regulators with Working Principle". I am looking to use the overall block diagrams within my project.

Link: <https://www.elprocus.com/types-of-voltage-regulators-and-working-principle/>



Different Types of Voltage Regulator and Working Principle

Different Types of Voltage Regulators with Working Principle A voltage regulator is used to regulate voltage levels. When a steady, reliable voltage is needed, then the voltage regulator is the preferred device. It generates a fixed output voltage that remains constant for any changes

www.elprocus.com

Figure 93: ElProCus Copyright Permission

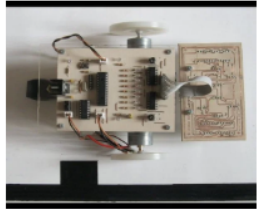
Image Permission Request



Heba Nasserreddeen  
Thu 4/16/2020 11:01 PM  
info@instructables.com

Hello,

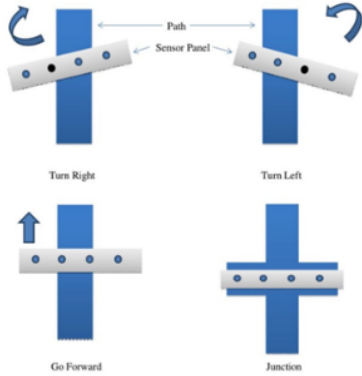
I am a student at the University of Central Florida working on a Senior Design Capstone Project. I wanted to request permission to use an image from your page : [Follower/](#) for our research paper. The image is copied below:



Complete Guide to Design an Advanced Line Follower Robot : 5 Steps (with Pictures) - Instructables

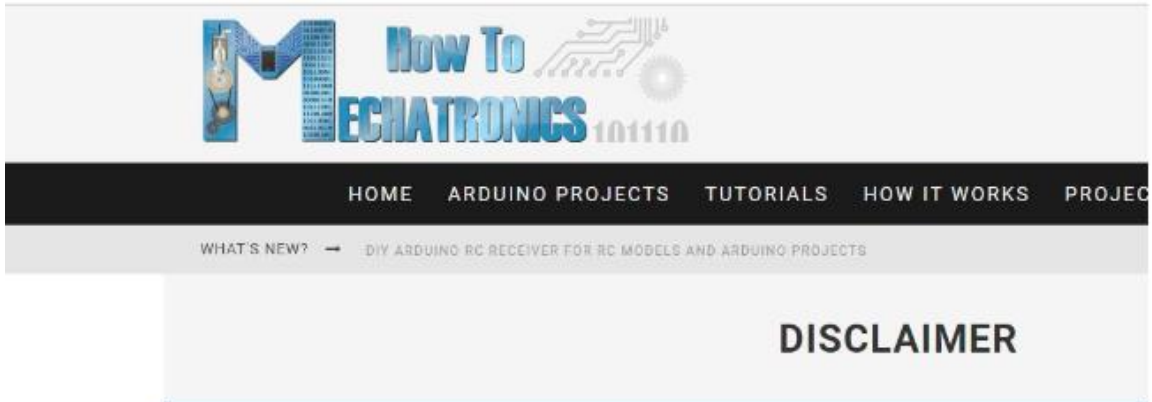
Complete Guide to Design an Advanced Line Follower Robot : Line follower is an autonomous robot which can detect a specific colored line painted on a surface of different contrast, such as white on black. In this project I used infrared transmitters and receivers to track the black strip on white surface....

www.instructables.com



Thank you,  
Heba Nasserreddeen

Figure 94: Instructables Image Copyright Permission



The information contained in this website is for general information purposes only. The information is provided by How to Mechatronics and while we endeavor to keep the information up to date and correct, we make no representations or warranties of any kind, express or implied, about the completeness, accuracy, reliability, suitability or availability with respect to the website or the information, products, services, or related graphics contained on the website for any purpose. Any reliance you place on such information is therefore strictly at your own risk. Every material on this website may not be the original idea of the webmaster and may have been borrowed ideas and/or submitted by visitors.

The information provided on the HowToMchatronics.com may be used, copied, remix, transform, build upon the material and distributed for any purposes only if provided appropriate credit to the author and link to the original article.

In no event will we be liable for any loss or damage including without limitation, indirect or consequential loss or damage, or any loss or damage whatsoever arising from loss of data or profits arising out of or in connection with the use of this website

*Figure 95: How To Mechatronics Copyright Permission*

[The Pi Hut Support] Re: Copyright Permission



Support <contact@thepihut.com>  
3/17/2020 10:17 AM



To: Sadiyah Bhuria

##- Please type your reply above this line -##

Your request (58755) has been updated. To add additional comments, reply to this email.



Jamie Mann (The Pi Hut Support)

Mar 17, 14:16 GMT

Of course, I hope the design project goes well



Sadiyahsalim

Mar 17, 04:30 GMT

I'm a Senior student studying at the University of Central Florida and I am writing documentation for my Senior Design 1 Project that includes the information of your products.

May I have permission to use the information and images of the products from your website?

Looking forward to hearing from you.

Thank you

Sadiyah Bhuria

Figure 96: Pi Hut Image Copyright Permission

Re: Copyright Permission



PiShop.us - Support <support@pishop.us>  
3/16/2020 8:01 AM



To: Sadiyah Bhuria

Hello Sadiyah,

Thank you for contacting us! We really appreciate your taking the time to ask us.  
Feel free to use any descriptions and pictures from our website.

How would you rate my reply?

[Great](#) [Okay](#) [Not Good](#)

Best regards,

Anneline Kraemer  
[PiShop.us](#) Support Team  
[support@pishop.us](mailto:support@pishop.us)

On Sun, Mar 15, 2020 at 9:56 PM UTC, Sadiyah Bhuria <[sadiyahsalim@knights.ucf.edu](mailto:sadiyahsalim@knights.ucf.edu)> wrote:  
To whom it may concern,

I'm a Senior student studying at University of Central Florida and I am writing documentation for my Senior Design 1 Project that includes the information of your products.

May I have the permission to use the information and images of the products from your website?

Looking forward to hearing from you.

Thank you  
Sincerely,  
Sadiyah Bhuria

Figure 97: Pi Shop Image Copyright Permission



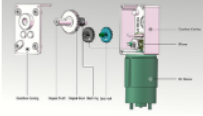
Hello,

I am working on my Senior Design paper and I wanted to use a diagram from your website to explain how gear motors work. I want to ask permission if I can use the diagram on my paper for educational purpose. With your permission, I intend to correctly cite your website in my paper.

Below is the link of the page where I found this diagram:

<http://www.etonm.com/support/i=33&comContentId=33.html>

I am also adding the image here for reference as well.




Thank you,

Abdulsalam Khan  
University of Central Florida

*Figure 98: Diagram of Gear Motor Copyright Permission*

Permission request for reproduction of a Diagram



Hello,

My name is Abdulsalam Khan and I currently an undergraduate student at the University of Central Florida, US. I am asking for permission to use a diagram of motor system in my Senior Design class report for a project to explain the IEC motor standards. With permission, I intend to only reproduce the diagram in my report for educational purpose and correctly cite the source of your website.

The diagram I am asking the permission for is found on the following link:  
[https://www.iec.ch/perspectives/government/sectors/electric\\_motors.htm](https://www.iec.ch/perspectives/government/sectors/electric_motors.htm)

Examples by industry sector: Electric motors - measuring efficiency  
IEC - Governments & International Organizations  
[www.iec.ch](http://www.iec.ch)

I have also attached an image of the diagram.

Please let me know if you need more information.

Thank you,

Abdulsalam Khan  
University of Central Florida  
4000 Central Florida Blvd,  
Orlando, FL 32816, US  
Email: [Abdulsalam.Khan1@Knights.UCF.edu](mailto:Abdulsalam.Khan1@Knights.UCF.edu)

*Figure 99: Classification of Motor System from IEC Copyright Permission*