

Object Detection Drone



**University of Central Florida EECS
Senior Design 1
Summer 2020**

GROUP 13

Kristian Aspi - Computer Engineering
Jacob Bendele - Computer Engineering
Hussain Mohammad - Electrical Engineering
Anthony Pionessa - Computer Engineering

Table of Contents

1.0 Executive Summary	1
2.0 Project Description	2
2.1 Project Motivation and Goals	2
2.2 Objectives	2
2.3 Requirements Specifications	4
2.3.1 Engineering Requirements	4
2.3.2 Hardware Requirements	5
2.3.3 Software Requirements	6
2.3.4 Cost Requirements	6
2.4 Quality of House Analysis	8
2.5 Block Diagrams	9
3.0 Research Related to Project Definition	12
3.1 Existing Similar Projects and Products	12
3.1.1 Consumer Market	12
3.1.2 Commercial Market	12
3.2 Relevant Technologies	13
3.2.1 Inertial Measurement Unit (IMU)	13
3.2.2 Flight Controllers	15
3.2.2.1 Flight Controller Firmware	18
3.2.3 Transmission Technologies	20
3.2.4 Receivers and Transmitters	22
3.2.5 Motors	22
3.2.6 Propellers	25
3.2.7 Electronic Speed Controller (ESC)	28
3.2.8 Lithium Polymer Batteries	30
3.2.9 3D Printing	33
3.2.9.1 ABS vs PLA	34
3.2.10 Power Distribution Boards	35
3.2.11 Cameras	35
3.2.12 Computer Vision	37
3.2.12.1 Object Detection	38
3.2.12.2 Neural Networks and Convolutional Neural Networks	39
3.2.12.3 Algorithms & Detectors	40
3.2.13 Application Development	45
3.2.14 Mechanism and Motion	46
3.3 Parts Selection	47

3.3.1	Frame Materials	47
3.3.2	Motor and Propeller Selection	48
3.3.3	ESC	50
3.3.4	Camera	51
3.3.5	Battery	56
3.3.5.1	Cell Chemistries	56
3.3.5.2	Lithium Polymer Battery Choice	58
3.3.6	Video Transmission	59
3.3.6.1	Transmission Technology	59
3.3.6.2	Video Transmitters	62
3.3.6.3	Video Receivers	66
3.3.7	Drone Controller	68
3.3.8	Flight Controller	71
4.0	Related Standards & Design Constraints	74
4.1	Related Standards	74
4.1.1	Battery Standards	75
4.1.2	Design Impact of Battery Standards	77
4.1.3	Drone Standards	78
4.1.4	Design Impact of Drone Standards	79
4.1.5	Additive Manufacturing Standards	80
4.1.6	Additive Manufacturing Standards	80
4.1.7	Radio Frequency Standards	80
4.2	Design Constraints	83
4.2.1	Economic and Time Constraints	83
4.2.2	Environmental, Social, and Political Constraints	83
4.2.3	Ethical, Health, and Safety Constraints	84
4.2.4	Manufacturability and Sustainability Constraints	84
5.0	Project Hardware Design Details	86
5.1	Drone Subsystem	86
5.1.1	Frame Material	87
5.1.2	Frame CAD	87
5.1.3	Motor Mount CAD	88
5.1.4	Body Component Placements	89
5.2	Flight Subsystem	91
5.2.1	Flight Controller	91
5.2.2	Flight Controller Breadboarding	92
5.2.3	Motor and Propeller Thrust Calculations	93
5.3	Power Subsystem	93

5.3.1	Power Supply	93
5.3.1.1	Flight Time Calculations	94
5.3.1.2	Full Throttle Analysis	94
5.3.2	Power Distribution Board	95
5.3.2.1	Voltage Regulator Design	96
5.4	Detection Subsystem	98
5.4.1	Camera	98
5.4.2	Ground Control System Design	102
5.4.2.1	Remote Transmission	102
5.4.2.2	Video Receiving	103
5.5	Overall Component Mass	104
5.6	System Overview	105
6.0	Project Software Design	106
6.1	Mobile Application	106
6.1.1	Development Environment and Platform	106
6.1.2	Pilot Companion Application Design	107
6.1.3	Pilot Companion Application Development Paths	110
6.2	Firmware Tuning	112
6.2.1	PID Tuning with Cleanflight	112
7.0	Project Prototype and Testing Plan	114
7.1	PCB Prototype and Sourcing	114
7.2	3D Printing	117
7.2.1	Motor Mount Prototype	118
7.3	Hardware Test Environment	118
7.4	Hardware Specific Testing	119
7.4.1	Motors	119
7.4.1.1	Internal Shorts or Damaged Windings Test	119
7.4.1.2	Broken Magnets or High Friction Test	120
7.4.2	ESC	121
7.4.2.1	Output Waveform Test	121
7.4.3	Flight Controller	123
7.4.3.1	Power on Recognition Test	123
7.4.4	Camera	123
7.4.4.1	Video Signal Test	123
7.4.5	Remote Control Transmitter and Receiver	125
7.4.5.1	Remote Controller TX/RX Test	125
7.4.5.2	CPPM Signal Test	126
7.4.6	Video Transmitter and Receiver	127

7.5	Software Test Environment	128
7.6	Software Specific Testing	129
8.0	Administrative Content	130
8.1	Milestone Discussion	130
8.2	Budget and Finance Discussion	131
9.0	Project Summary and Conclusion	132
	Appendix A - Copyright Permissions	133
	Appendix B - References	143

List of Figures

Figure 2.1: House of Quality	8
Figure 2.2: Hardware Block Diagram	10
Figure 2.3: Pilot App Software Block Diagram	10
Figure 2.4 Embedded Software Block Diagram	11
Figure 3.1: Example of a Commercial Drone	13
Figure 3.2: Overview of an Inertial Measurement Unit	14
Figure 3.3: Calculating DR position using Drift angle	15
Figure 3.4 Flight Controller Loop Depiction	19
Figure 3.5: Example of Channel Interference by Same Frequency	21
Figure 3.6 Dominant vs Non-Dominant Interferences	22
Figure 3.7: Brushed and Brushless DC Motors Comparisons	23
Figure 3.8: Front view of a BLDC motor rotor and stator	24
Figure 3.9: 6 Coil Configuration with Corresponding Current Waveform	24
Figure 3.10: Carbon Fiber Propellers	26
Figure 3.11: Different prop pitches	27
Figure 3.12: Different prop blade amounts	28
Figure 3.13: Electronic Speed Controller Internal Workings	29
Figure 3.14: Electronic Speed Controller	30
Figure 3.15: Lithium Ion Example 1	31
Figure 3.16: Lithium Ion Example 2	31
Figure 3.17: Li-Ion vs. Li-Po	32
Figure 3.18: Power Distribution Board with FC	35
Figure 3.19: Resolution Comparison	36
Figure 3.20: Camera with Builtin Transmitter	37
Figure 3.21: 3D Printed Camera Mount	37
Figure 3.22: Classification	38

Figure 3.23: Pedestrian Detection Results Using Different Techniques	39
Figure 3.24: Feature Learning and Classification	40
Figure 3.25: Image and Convolved Feature	40
Figure 3.26: Regions with CNN Features	42
Figure 3.27: YOLO Grid Cell Example	43
Figure 3.28: Single Shot Multibox Detector (SSD)	44
Figure 3.29: Types of Motion of a Drone	46
Figure 3.30: Overall Components	47
Figure 3.31: EMAX RS2205-S 2300KV	50
Figure 3.32: AKASO EK70000 and GoPro HERO	53
Figure 3.33: RunCam Phoenix 2, BETAFPV Z02, and Caddx Firefly	55
Figure 3.34: Examples of Wi-Fi Signal Pathing	60
Figure 3.35: GOQOTOMO E-600 Video Transmitter	63
Figure 3.36: TBS Unify Pro32, TBS Unify Pro 5G8, and Eachine TX805	64
Figure 3.37: Eachine ROTG01, Eachine ROTG02, Skydroid OTG, RC832HD	68
Figure 3.38 Navio2 HAT Attached to Raspberry Pi 3 and X-Racer F303 Flight Controller	72
Figure 5.1: Common Quadcopter Frame Shapes	86
Figure 5.2: Two 2 Feet 1/2" Inch Sch 40 Pipes and 4 1/2"x1/2"x1/2" Tees	87
Figure 5.3 PVC H Frame Design Dimensions	88
Figure 5.4: Motor Mount CAD	88
Figure 5.5: Stress Test Analysis	89
Figure 5.6: CAD Model of Our Top Mounted Battery Drone	90
Figure 5.7: Naze32 Components	92
Figure 5.8: Lipo + FC + Motor Breadboard Demo	92
Figure 5.9: Voltage Regulator Schematic	97
Figure 5.10: 5V Regulator Breadboard	97
Figure 5.11: Mobius Action Camera	98

Figure 5.12 Inside of the Mobius Action Camera	99
Figure 5.13: Mobius Action Camera Breakout Cable	99
Figure 5.14: Mobius Action Camera Breakout Cable and Breadboard	100
Figure 5.15 Eachine TX805 Schematic	101
Figure 5.16: Camera System Design	101
Figure 5.17: Flysky FS-i6x Controller and Receiver	102
Figure 5.18: Drone Controller Receiver Connection Design	103
Figure 5.19: Example of the Video Receiver and Phone Connection	103
Figure 5.20: Overall Electronic Design Schematic	105
Figure 6.1: Pilot Companion App Use Case	107
Figure 6.2: Pilot Companion App Class Diagram	108
Figure 6.3: GUI Home Screen (background: unsplash x)	109
Figure 6.4: GUI Menu Screen (unsplash x)	109
Figure 6.5: GUI Detection and Stats Screen (unsplash x)	110
Figure 7.1: PCB Design on Eagle	116
Figure 7.2: Design for Manufacturability (DFM) Report	116
Figure 7.3: Gerber Files Returned from Manufacturer	117
Figure 7.4: Motor Mount Prototype	118

List of Tables

Table 3.1: STM32 F1, F3, F4, and F7 Processors on Flight Controllers	15
Table 3.2: ABS and PLA Printing Properties	34
Table 3.3: Different materials and their properties	48
Table 3.4: Motor Comparison Summary	50
Table 3.5: ESC Comparison Summary	51
Table 3.6 Possible Camera Summary	56
Table 3.7: Battery Cell Technology Comparison	58
Table 3.8: LiPo Battery Comparison	59
Table 3.9: Possible Transmitter Technologies Summary	62
Table 3.10: Possible Video Transmitter Comparison Summary	66
Table 3.11: Possible Video Receiver Specifications Summary	68
Table 3.12: Possible Drone Controller Specifications Summary	71
Table 3.13: Different versions of the Naze32 FC	73
Table 5.1: Motor + Prop Thrust Calculations	93
Table 5.2: Overall Component Mass Table	104
Table 7.1: Ender 3 Print Settings	117
Table 7.2: Motor Generation Test	120
Table 7.3: Motor Temperature Test Results	121
Table 7.4: Flight Controller Power On Recognition Test Results	123
Table 7.5: TX805 Power On Test Results	128
Table 8.1: Project Milestones	130
Table 8.2: Project Budget	131

1.0 Executive Summary

The first use of the term drone to describe an unmanned radio controlled aircraft dates back to as early as the 1920's. These early drones were not like what one imagines flying through the sky today. In fact, they were full sized planes used primarily for target training by the military. Drones have come a long way since then and have cemented their form in a 4 rotor design called a quadcopter. These quadcopter designs can range from sizes small enough to fit in the palm of your hands to sizes large enough to need both hands to carry. The quadcopter blueprint rapidly developed when electronics were able to keep up with the lightweight, cheap, sensor packed boards used for flight control. These flight control boards emerged around the mid 2000's and are the brains to every modern drone. Following the development of flight controllers, the consumer drone market really started to take off in 2013 with camera mounted drones directed at film makers.

Concurrent to the drones development in the past decade, computer vision has been making its rise as a forefront topic in research and industry. Computer vision publications have been rising rapidly especially in fields, such as object detection. Just last year the amount of publications containing *Object Detection* in the title surpassed 2000.^[70] Companies like Uber and Tesla are funding and developing advanced computer vision systems for cars in a race to create fully autonomous vehicles. Even in your local retailers you might see security monitors tracking your face as you walk through the doors. So what does this all mean?

To us, drones are a modern technology that have only broken into the consumer market as of very recently. This provides us the ability to explore creating a drone in an era where there is a lot of previous research and information, but still many more new things to discover. Additionally, computer vision has seen its own rise in popularity in today's industry. Computer vision and object detection have been featured in drones before, but there are many problems that can still benefit from this duo. We want to start from the ground up, building a drone, computer vision detection system, and pilot application.

The goal is to utilize our drone system to count objects and relay them back to the pilot via a phone application. Some examples of objects we have proposed are cars, people, boats, etc. The detection systems currently on the majority of consumer drones are meant for object avoidance and tracking people for photography. By using the drones aerial view capabilities we can capture video and images of the scene. The proposed detection system will utilize these images and videos to detect and count objects. The pilot application will present the live camera view for navigation. Once the camera is situated over the scene the pilot will see bounding boxes around the detected objects in the live view.

2.0 Project Description

This section will serve to provide a description for our Object Detection Drone, as well as discuss the motivations behind the project as a whole. Additionally, discussion on the objectives we hope to accomplish as well as the requirements that we have set forth for our project will be available here.

2.1 Project Motivation and Goals

The motivation for pursuing this project stems from the teams mutual interest in drones as well as computer vision. Prevalent companies in today's industry like Amazon, Shell, Google, Tesla, and too many more to name, are researching, developing, and realizing applications in both the fields of drones and computer vision. Having the opportunity to work as a team and develop skills in these domains is a major goal for all of us. Additionally, we want to push ourselves to fully utilize what we have all learned at the University of Central Florida. Another of our goals is to properly research, design, and create a tangible prototype. By doing so each team member will be one step further into developing their careers and personal interests. Lastly it is a fun engineering project that encompasses both CPE and EE knowledge!

2.2 Objectives

Overall our Object Detection Drone Project will consist of four subsystems: The Drone Subsystem, Flight Subsystem, Power Subsystem, and Detection Subsystem. In addition to the four subsystems above, there will also be a companion smart phone application for the pilot. The objectives for each of the subsystems as well as the pilot companion app will be reviewed here, but more in depth details for each individual component can be found in section 5.0 Project Design Details.

The Drone Subsystem encompasses all of the physical design of the Object Detection Drone. Our objective for the chassis is to design a lightweight, medium sized aerial drone based on the well known quadcopter blueprint. The Drone Subsystem should be capable of carrying a camera as a payload. Additionally, the physical structure of the drone should adhere to a modular design supporting swappable hardware components. By considering modularity to be one of our objectives we aim to create an easily serviceable prototype when it comes to the battery, propellers, and motors.

Our Flight Subsystem consists of the brains and flight controls of the Object Detection Drone. Our number one objective with this subsystem is simply to get the drone off the ground under its own power. Getting off of the ground can be broken down into three main tasks: takeoff, flight, and landing. Within these tasks

we have smaller, but equally important objectives for the Flight Subsystem. Ultimately during takeoff and landing we want to make sure the drone does not suffer any catastrophic damage. While our goal for both takeoff and landing pertain to not damaging the drone, our inflight goals pertain to the flyability of the drone. To us flyability consists of the drone reacting to the commands sent to it, as well as the drone's ability to hover and maintain altitude.

Responsible for powering the entire project is the Power Subsystem. Our objective for this subsystem is to design a reliable powering method for all of the electronic components of the drone. This subsystem can be broken down into two major parts. The first of the two parts that compose the Power Subsystem is the power source. An objective regarding the power source is to make sure it is sufficient for the power draw of the drone electronics and flight times we are looking to achieve. The second part is the power distribution. We must make sure the distribution for the power source is accurate for components being driven, as well as its ability to handle power draw for all systems onboard the drone.

The last drone system to discuss is the Detection Subsystem. When taking a look at the consumer market almost every drone has an integrated camera for taking still images as well as video. This is shared with our design, but our main objective for the Detection Subsystem is to pursue utilizing the affixed camera for a more interesting use case; object detection! The computer vision implementation is what sets our drone apart from many of the others found on the market. While other drones have gone fully into the photography and videography realms with hovering for a photo or tracking a face, we wanted to leave our design more open ending. By having the ability to train the detection model on many classes our drone can be extensible in the types of objects detection tasks. This system will be composed of the camera as well as the transmission hardware necessary to relay the video from the drone to the pilot companion app. Our main objective with this subsystem is creating a stable video transmission. Without a stable video transmission our drone pilot will be flying by sight only and our detection software will have no input to run against.

In addition to the drone our project will also have a companion smart phone application for the pilot. This application will showcase a live feed view from the camera of the drone. This live feed will be processed using the phone's resources to implement the object detection software. The phone application will show bounding boxes around detected objects, object count, and in the case of multiclass object detection, assign a color corresponding to class type.

2.3 Requirements Specifications

Before a system or project can start the design process, requirement specifications must be established and be detailed enough to make analysis and design possible. The following subsections include the Engineering, Hardware, Software, and Cost Requirements of our project. The Engineering Requirements describe measurable aspects of what our project aims to do. The Hardware Requirements describes the physical hardware of our project which is mostly the quadcopter drone aspect. The Software Requirements describes the computer vision, drone communications, and phone applications aspects of our project. The Cost Requirements estimates the costs of the entire project along with any constraints.

2.3.1 Engineering Requirements

- Detect object in real time which is within 2 minutes
- Counting detected objects with 80% or greater accuracy
- Main components of drone shall be easily replaceable/modular
- Have at least a 2:1 thrust power to weight ratio
- Flight time greater than or equal to 5 minutes
- Flight altitude less than or equal to 400 feet
- Object detection with 80% or greater accuracy
- The power source shall be capable of charging via power outlet
- The drone shall not exceed 2 kilogram
- The output current for the flight controller/escs shall be greater than the combined draw of the motors 122 amount of amps
- The power distribution board regulators shall be rated for 15% or greater headroom of maximum current draw
- The drone camera shall record at a high enough resolution for object detection; greater than or equal to 720p
- The drone shall reach a speed of greater than or equal to 10 mph or 4.47 m/s
- The drone will be capable of stable hover for at least 5 minutes
- The drone must have landing gear that creates at least 3" of ground clearance
- The drone must be able to land safely on both concrete and short grass
- The pilot companion app shall work on the android operating system
- The pilot companion app shall consist of a live drone view and a basic menu system
- The pilot companion app shall be no larger than 200 MB
- The flight controller shall have at least 2 available UART ports for accessories
- The onboard antennas shall be mounted in a V or L shape in reference to each other
- The onboard antennas shall be free from metal or carbon obstructions
- The motor size in kv shall not exceed 4000 kv

- The propellor size shall be no smaller than 2 inches in length
- The drone subsystem (chassis) shall provide basic weather protection to the electronic components
- The drone subsystem (chassis) shall have adequate open spacing and/or ducts for cooling of the electronic components
- The drone shall operable at a distance of at least 50 feet

2.3.2 Hardware Requirements

Frame: Frame size measured from two opposing motors. Our drone project will most likely fall under the medium to large drone size.

- 80 - 100 mm nano-drone
- 100 - 150 mm micro-drone
- 150 - 250 mm small-drone
- 250 - 400 mm medium-drone
- +400 mm large-drone

Flight Controller: Acts as the pilot of the drone which handles flight response by controlling the direct RPM of each motor in response to input.

Electronic Speed Controller: Four Electronics Speed Controllers (ESC) will be needed. The ESC accepts a DC input voltage and produces three out of phase voltages that feed the motor's inputs.

Motors: Four brushless motors will be used. Brushed motors, though cheaper, are not as efficient and wear faster.

Propellers: Standard propellers will be bought and size will be determined by the estimated frame size, weight, and motors.

Remote Controller: Will either be a bought or built controller. A standard bought controller is ideal for reliability and precision for control. An attachment to mount a phone on the controller can be made via 3D printing. The phone will display the aerial feed from the camera systems on the drone. The physical controller will allow more precise control of the drone.

Power Distribution Board: Breaks out the power source into multiple different connection points for a cleaner wiring and build. Additionally, provides DC-DC conversion for components that do not operate at power source voltage.

Battery: Our battery pack will have to sustain all of the drone functions from motors to sensors. The size of the battery will depend on multiple things:

- Desired flight distance
- Desired flight speed: Dependent on motor power
- Flight Controller and electronics

- **Weight:** the bigger the drone and the heavier components will affect the battery size necessary to reach desired flight distance. Battery weight must also be taken to account.

Camera: Used to get point of view from drone for video processing and flight navigation.

Video Transmitter: Allows transmission of video feed from the drone to the ground. Video is from the camera onboard the drone.

2.3.3 Software Requirements

Camera Detection System: The pilot companion application will utilize the host phone's computational power to implement the detection algorithm. The system will have to see the lower surroundings of the drone while hovering and detect obstacles (people or otherwise) via Artificial Intelligence/ Machine Learning. We plan to utilize an open source detection program.

Phone Display Feed: The user's phone will display the camera feed from the drone in a landscape style that will occupy the entirety of the user's phone screen. On the camera feed will be a visual representation of what the drone is seeing through the use of Artificial Intelligence/Machine Learning. A color coordinated indication system will be in place to alert the user of detections by the drone.

App: The app will display the camera feed of the drone with the features of the phone display feed. The camera feed will not have any user interactivity. On top of the camera feed will be a translucent set of control areas that will have touch sensitivity to control the drone. The controls will control the height, the movement, and the camera of the drone. The translucent control buttons through the app might not offer as precise of control of the drone compared to using a physical controller made for drones.

Firmware: The multitude of hardware components that will be needed will require parameter tuning and integration together. This will be done via programming parameters into the hardware's firmware. Additionally, by utilizing protocols between the hardware devices we can communicate data between them.

2.3.4 Cost Requirements

The Cost analysis for the drone gives us great insight and enables us to make intelligent decisions. These enable us to choose the best components for the drone while following the financial boundaries of the project.

Owing to the fact that drones are modern technologies, they are expensive as well. So our aim is to manufacture the best possible drone in the least possible budget with maximum features.

The material used in the frame of the drone will be of great importance as the material will have a great impact on the budget of the drone.

The most expensive yet having high strength to weight ratio material is carbon fiber. This will make the drone lighter as it has very low weight which affects the other components of the drone to exert less thrust and the motors used will be of less power which will lessen the cost but to the fact that carbon fiber is very expensive we can compensate on the other components.

The motors we use in the drones will be brushless DC motors which will have an advantage for high torque to weight ratio and increased reliability and smooth flight. This causes the drone to operate on less energy consumption which in turn requires a smaller battery. On the other hand, brushed motors require high power which will drain more energy. This causes flight time to decrease, while also increasing the cost for other components.

Batteries which are used are Lipo batteries which are cheaper and are more effective than acid electrolyte batteries. Moreover, they are also lighter than acid electrolyte batteries which makes it perfectly suitable for the drones.

Moreover, Lipo batteries are a bit more expensive than Lead acid batteries but they compensate for higher capacity, depth of charge, and efficiency. It makes the lifespan of the batteries longer and the overall performance of the drone better.

We are using the Naze32 flight controller which is cheaper than others. We have an option for advanced autopilot flight controllers which have integrated power distribution boards and ESC, but they are expensive and would breach our financial boundaries.

Propellers are important to the drone's flight effectiveness. The hard plastic propellers are much lighter than any metal propellers such as aluminum.

The aluminum propellers can be cheaper but the Plastic propellers, owing to the fact that they are lighter and provide much more thrust makes the suitable option. Moreover, they would contribute less to the overall weight of the drone.

Camera selection will be based mainly on the price, resolution, and weight of the camera. Most higher resolution cameras are more expensive. However, choosing to go with a less expensive camera might not affect the resolution too much while decreasing the cost. Moreover, some cameras designed for drone FPV are lightweight, and have enough resolution for our purposes. This decreases our

cost and the overall weight of the drone. This in turn will help us not require more powerful motors either.

The Base Plate of a Drone plays a major role in smooth flight and sustainability of a drone. It is mostly made of Aluminum for greater stability. Carbon Fiber is lightweight but the frame needs stability with precise strength to weight ratio which Aluminum metal can provide easily.

Receivers and Transmitters can be easily chosen as it has very limited variety and it is cheap so it can be chosen easily and more conveniently.

2.4 Quality of House Analysis

The following section will have the house of quality breakdown for the project. The figure compares the correlations between the engineering requirements and the user requirements.

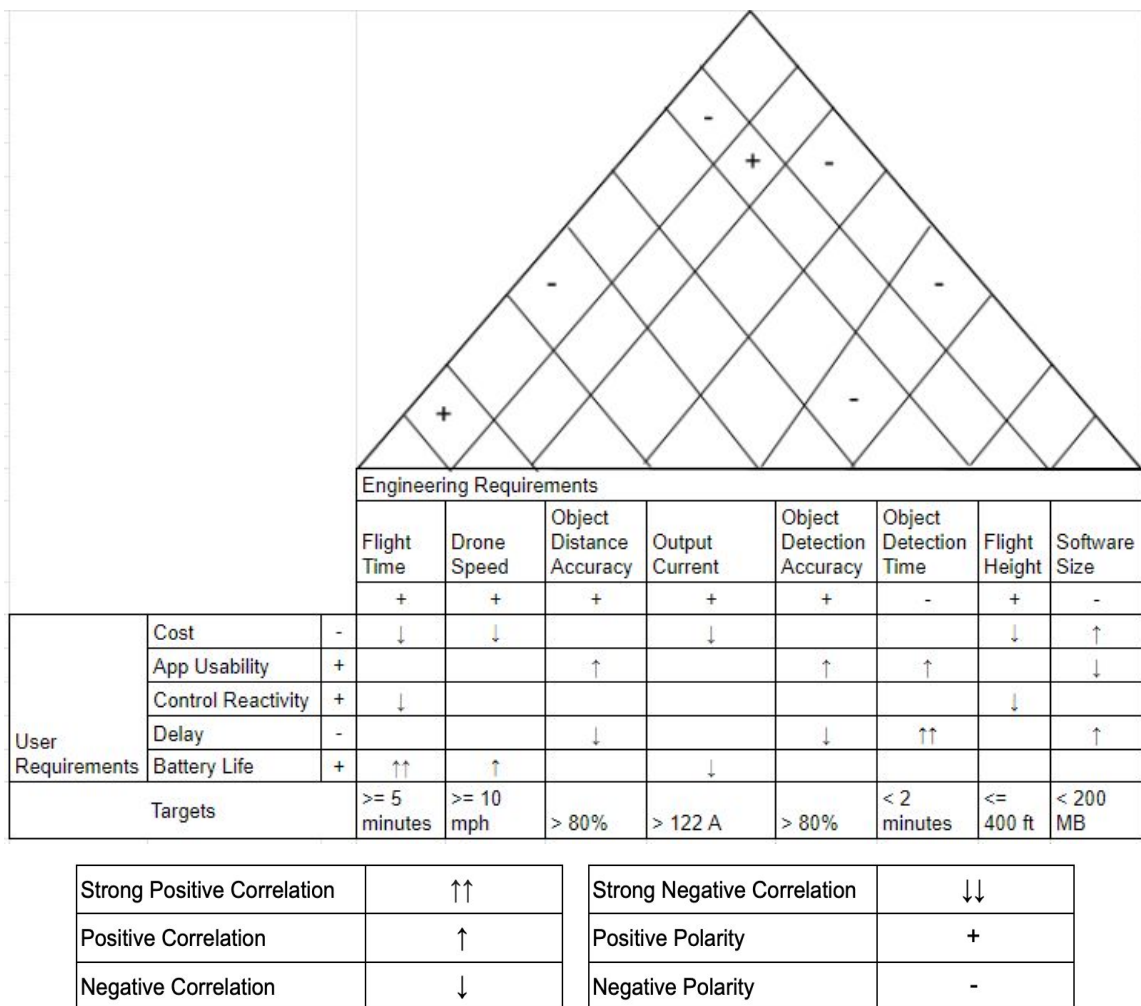

Figure 2.1: House of Quality

The user requirements are requirements that we have set in which we believe they will improve the quality of use for the customer. These requirements include properties such as the overall cost of the product since the more affordable the product is, a wider range of customers can be targeted for it. Another user requirement that we chose to pursue is the control reactivity of the drone. If the controls do not react as quickly as they should or if the controls are too sensitive, then the user can have a negative experience flying the drone, especially if they are not an experienced pilot. The user requirement for application usability is a significant one due to our goal of providing a positive experience for the consumer. We want the application to be easy to use so everyone can have the ability to download the application, start running it, and have success with the minimum amount of assistance as we can.

On the other side of the requirements, the engineering requirements is the list of requirements that we want to meet or exceed on the design and technical side of the project. The engineering requirements also provide our requirements that we plan on testing and are able to be tested in a demonstration. When we demonstrate our project, we want to have several requirements that we can show within the time that we take for our demonstration. One of these engineering requirements is the requirement for the object detection time, so the time that it takes our application to process and detect the objects that we are looking to detect. We want to have the ability to output the finished detection within a couple of minutes which is a timeline that would be appropriate to a demonstration. The flight height of the drone is another engineering requirement that is able to be demonstrated and tested. We want to have the ability of the drone to travel at a height that is suitable for obtaining an excellent vantage point where the drone's camera can capture a significant amount of ground to simulate an event, such as an outdoor concert or music festival.

2.5 Block Diagrams

The hardware block diagram below shows the relationship between the components that were overviewed in section 2.3.2 Hardware Requirements as well as the division of work for which member(s) are responsible for the component.

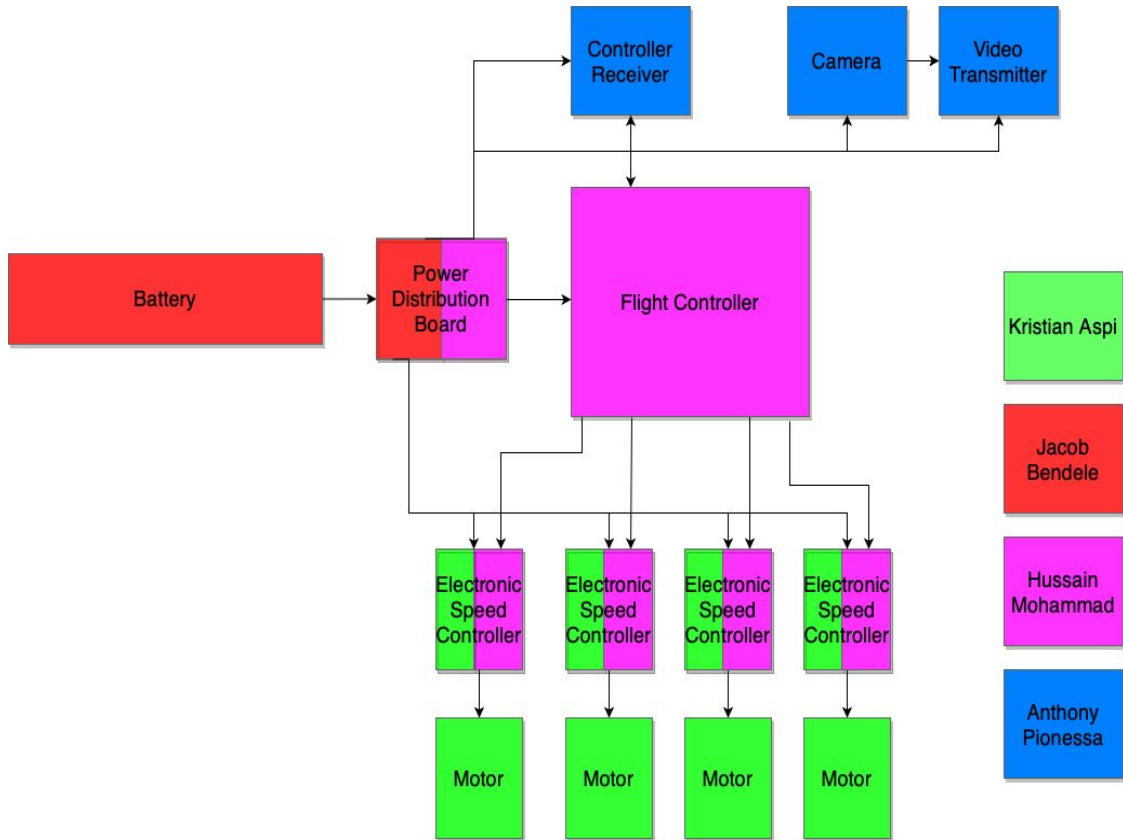

Figure 2.2: Hardware Block Diagram

The pilot application software block diagram below shows an overview of the system as well as the division of work for which member(s) are responsible for the block. The details of which are mentioned in section 2.3.3 Software Requirements.

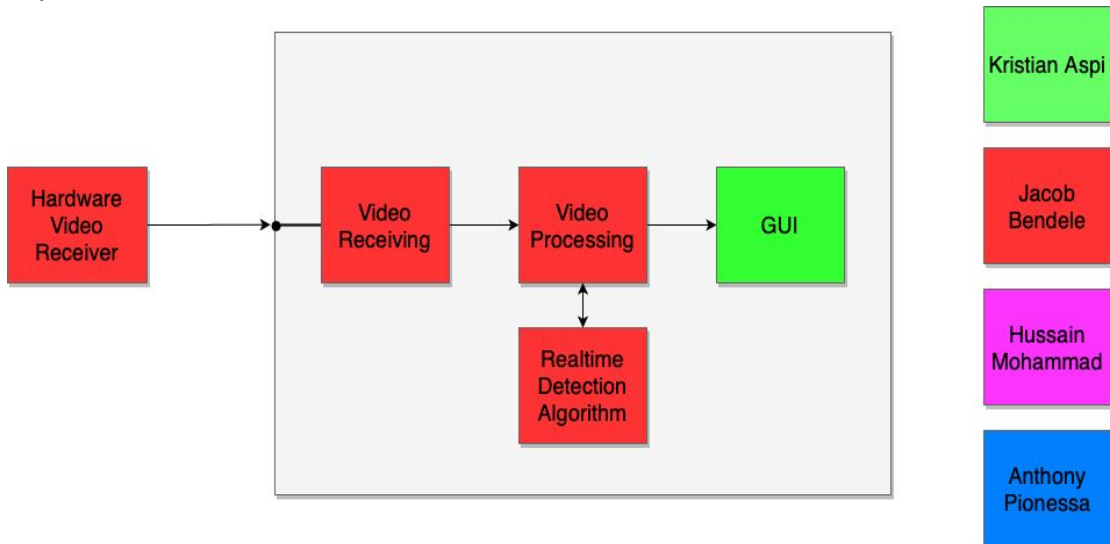

Figure 2.3: Pilot App Software Block Diagram

The embedded software block diagram below shows an overview of what software is necessary to integrate our hardware components as well as the division of work for which member(s) are responsible for each component. The details of which are mentioned in section 2.3.3 Software Requirements.

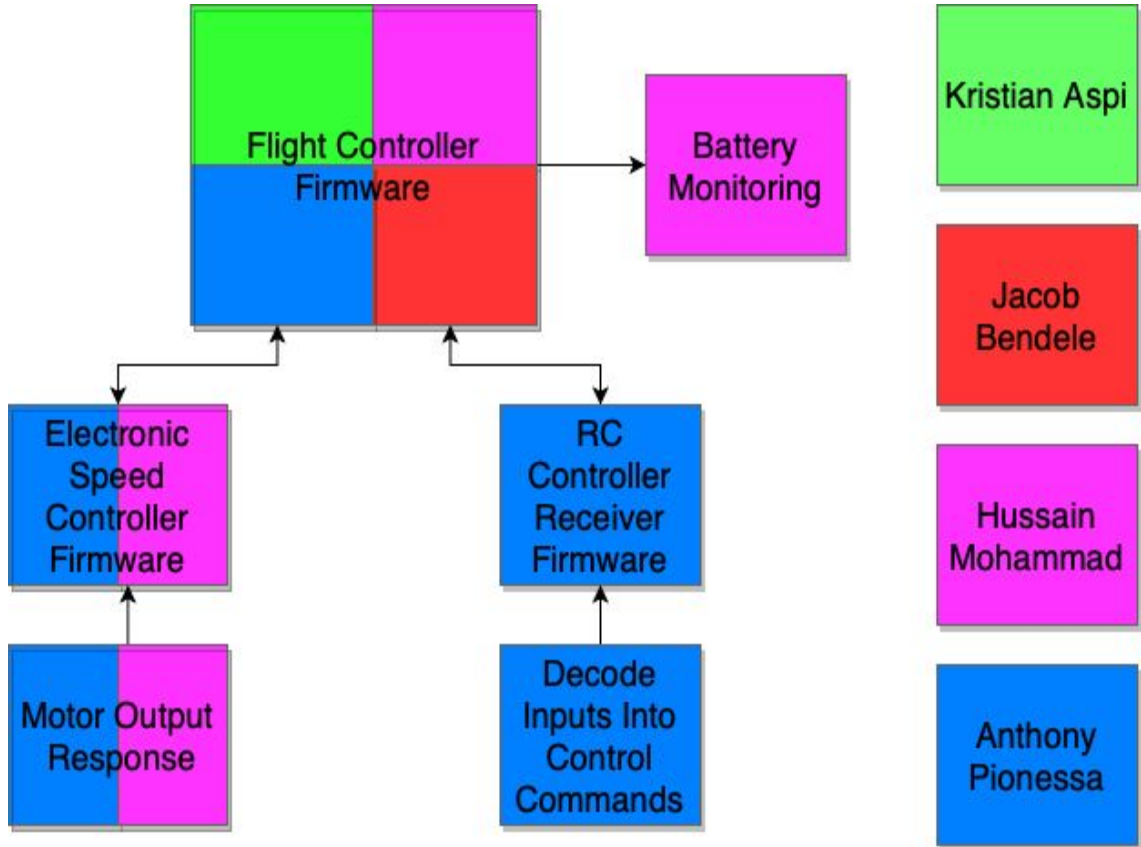

Figure 2.4: Embedded Software Block Diagram

3.0 Research Related to Project Definition

The following section includes the groups research developed by each member. This section is split into three subsections: Existing Similar Projects and Products, Relevant Technologies, and the Parts Selection Summary. The research within this section will help guide the decisions of designs and optimize the building process of our project.

3.1 Existing Similar Projects and Products

The idea of drone technology has been around for almost a century dating back to 1917 with the first unmanned winged aircraft in history, the Ruston Proctor Aerial Target. The market has expanded exponentially since then, pursuing the wake of the massive innovations within the field of electronics. As electronics became smaller, cheaper, faster, and more reliable so did the drone. Today a plethora of projects and products exist concerning drone technology. Further analysis into the comparison between our Object Detection Drone and today's drone market will follow.

3.1.1 Consumer Market

Mainly, drones produced for the consumer market today are for hobby, racing, and capturing images/videos. When visiting popular online retailers this is very apparent, as a simple query for the word “drone” results in hundreds of listings primarily boasting camera equipped drones. The cameras affixed to these drones satisfy being the eyes for the pilots, as well as taking photos and videos from the sky. But out of the hundreds of listings, only a handful of drones utilize computer vision. Similar to our Object Detection Drone these more premium drones also implement a form of object detection. What sets them apart? The consumer market drones focus on applying object detection to follow a person or take a picture when the subject is in frame. These tasks are fundamentally directed toward photography and cinematography. Our Object Detection Drone on the other hand, attempts to detect objects of multiple classes while additionally relaying the detected objects and count to the pilot. Overall, the key difference between our drone project and the current consumer market is the application of object detection.

3.1.2 Commercial Market

However, a range of projects within the commercial market also exists. Applications include using drones for transportation of medical supplies to remote areas, logging distances using GPS, and using IR sensors to detect heat signatures of humans in search and rescue scenarios. Although we were not

able to find a comparable commercial project, our drone fits well in this market. With venue managers needing a way to track hot spots within their locations or city workers requiring a traffic count on a busy intersection, we can derive that our drone's use cases are more similarly aligned with the commercial market. All in all, use of drones commercially is a popular topic today. However, to be readily used by industries, they must be reliable, fully compliant with safety and regulatory standards, fully autonomous, fully aware of airspace and be able to act on its own (take-off, landing, etc.).



Figure 3.1: Example of a Commercial Drone [52]

3.2 Relevant Technologies

A drone, defined by Merriam Webster, is “an unmanned aircraft or ship guided by remote control or onboard computers.” Something that was originally used as a weapon, in the form of Unmanned-Aerial-Vehicle (UAV) missile deployers, has trickled down to the commercial markets and used in a wide variety of applications. Drone growth is expected to increase even more in the upcoming years as technology and drone capabilities improve.

This section will incorporate the technologies that make up a drone along with the camera and computer vision aspects of our project.

3.2.1 Inertial Measurement Unit (IMU)

When in flight a drone requires a way to measure the external world acting on it. With enough information about these forces the drone can make decisions on how to stay in the air. Whether it is hovering, moving forward, or landing, one key device is very integral to the ability of a drone to perform its aerial maneuvers. This device is a combination of many sensors and is known as the inertial

measurement unit. The IMU is historically composed of gyroscopes and accelerometers. An IMU's functionality is measured in degrees of freedom (DOF). The 3D physical world as we know it has at maximum 6 DOF. This means that any object in its 3D space can translate in the x, y, and z directions along a plane, as well as rotate about the x, y, and z axes. Although there are only 6 DOF in physical movement in a 3D space, many IMUs advertise greater than 6 DOF capability as they combine other sensors to measure more than just movement. These additional sensors are usually in the form of magnetometers, thermometers, and barometers. It is the responsibility of the IMU to measure the most minute changes in these DOF. Using the data generated by the IMU a flight controller can take into account external forces, direction of travel, and angular orientation allowing the drone to react accordingly.

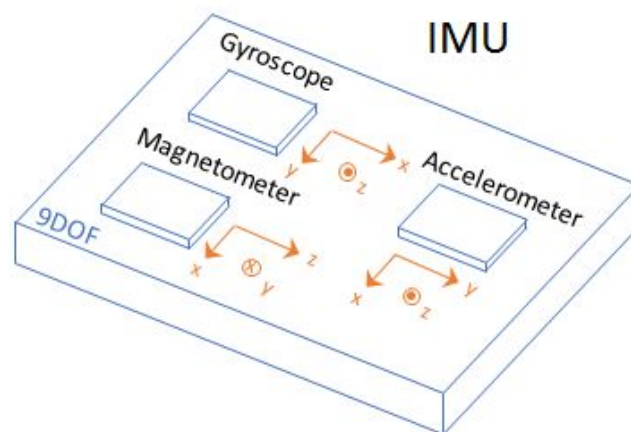

Figure 3.2: Overview of an Inertial Measurement Unit [53]

There is a major drawback to the operation of an IMU. The method for creating usable data from the internal sensors is via continuous integration. This goes back to physics where the integration of acceleration is velocity and the integration of velocity gives us position. Just like pencil and paper math the IMU only has so many givens to work with i.e the sensors' readings. The rest are unknowns that it must compute. The drawback is not in the physics, but in the paradigm of computation followed known as Dead Reckoning. Dead Reckoning is the process of determining position based upon estimations of speed and course over time. It was widely used in sea navigation. The worst part is that you are basing your calculations purely on estimations. Dead reckoning does not account for drift and IMUs are prone to this drifting effect. In addition to not accounting for the drift, by integrating this error gets compiled on top of each subsequent error.

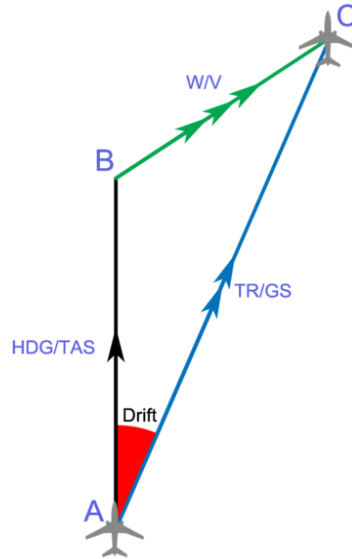

Figure 3.3: Calculating DR Position Using Drift Angle [54]

3.2.2 Flight Controllers

A flight controller is a small circuit board having a complex circuit inside. Its function is to manage the rpm of each motor individually according to the input signal provided by the receiver which receives signals from the transmitter.

One of the first known flight controllers was created by a Software Developer by the nickname 'Alexinparis'. Utilizing the Nintendo Wii MotionPlus remote connected to an Arduino Pro Mini, he developed control firmware and created the MultiWii controller board. This gave the idea of integrating all the components on one board and creating the modern flight controller we see today. This triggered the rise of the Naze32 flight controller boards.

Drone flight controllers can be found with various processors. Most drones used today operate on STM32 microcontrollers. Some of the various types of processors with STM32 MCU are F1, F3, F4, and F7.

Processor	Processor Speed	No. of UART Ports	Flash Memory
F1 (STM32F103CBT6)	72MHz	2	128KB
F3 (STM32F303CCT6)	72MHz	3	256KB
F4 (STM32F405RGT6)	168MHz	3	1MB
F7 (STM32F745VG)	216MHz	8	1MB

Table 3.1: STM32 F1, F3, F4, and F7 Processors on Flight Controllers [55]

F1 processors have the lowest processing power out of the four processors. They run at 72MHz clock rate and 128KB of flash memory. They can go up to 500 μ s looptime (2kHz). While it has the lowest processing speed, simple computations can be done with an F1 processor just fine. But due to delays caused by gyro and looptime plus other components, the physical reaction time of the motors to change speeds will be affected. Also, F1 processors include 2 UART ports. Lastly, one of the downsides to F1 flight controllers is that one of the two UART ports available is shared with the FrSky telemetry pins and the USB port. This means if we use UART 1, we cannot use the USB port for configuration; and if we use the telemetry pins, we cannot use the USB either. There are other ways, however. Soft Serial pins can be used for additional components, however this will increase looptime (2KHz will be unattainable).

The next type of processor is the F3. While it is the successor, it has the same clock rate of 72 MHz as the F1 processor and 256KB flash memory. However, it has faster floating point calculations due to the dedicated floating point unit (FPU). Moreover, F3 boards easily get up to 250 μ s looptime (4KHz), while running other peripherals such LED strips, accelerometer, Soft Serial, etc. A looptime of 125 μ s (8KHz) is also attainable with the accelerometer disabled. Lastly, the F3 offers three UART ports that are fully functional independently. This means all three can be used while also using the USB port. Another thing that sets these UART ports apart from the ones on most F1 boards is the built-in hardware inversion on them. This eliminates the need to use hacks and workarounds to run SBUS and SmartPort communication protocols.

The F4 processors were introduced shortly after the F3. These processors have approximately over twice the processing power of the F1's. The clock rate can reach up to 168MHz, with 1MB of flash memory and in some cases up to 180MHz with 512 KB or 2MB flash memory. Similar to F3 boards, these boards have a dedicated FPU. The looptime this processor offers varies depending on the configuration. If a MPU600 IMU is used with SPI protocol, the sampling ramping rate would be at 8KHz. However, with the ICM-20602 32KHz can be achieved. This is the restriction that limits the F4 board's looptime. The Gyro sampling rate must be higher or equal to the looptime; so if the Gyro sampling rate was 8KHz, the looptime cannot be set to 32KHz. Moreover, most F4 boards have three UART ports available. While others may have up to five UART ports. This allows you to utilize the full capabilities of the extra processing power. Similar to most F1 boards, F4 boards do not have built-in inversion capabilities.

Finally, the F7 processor. This is the fastest processor out of the above-mentioned four. It offers a clock rate of 216MHz, and flash memory of 1MB. The F7 can offer a looptime of 32KHz without overclocking as is done with F4 boards. However, this is not completely true due to the limiting of the Gyro sampling rate as mentioned above. An ICM-20602 IMU would be needed to

provide a higher sampling rate. Lastly, these boards can have up to eight UART ports with built-in signal inversion capability.

Flight controllers are usually equipped with sensors that allow us to control the drone. This is done by providing useful feedback control information concerning the surrounding environment of the drone and the orientation of the drone itself relative to the ground.

The barometer is a pressure sensor that is able to detect the air pressure around the drone. They are very sensitive. Enough so to detect slight changes in air pressure when the drone is moved vertically and changes altitude. This allows us to obtain accurate readings of the altitude the drone is being flown at. 'Acro' model flight controllers do not usually have a barometer. The reason for this is that there is no need for a barometer if the goal is just First Person View flight. Barometers come in handy when the drone needs to be somewhat autonomous and be able to stay at a constant altitude.

The function of the magnetometer (compass) is to detect the orientation of the drone during the flight. The orientation can be absolute or relative according to the references we set for the drone. This sensor is not vital to use for regular FPV flight. However, it is very useful for applications such as aerial photography since the accelerometer and gyroscope do not provide directional heading information but the magnetometer does. Magnetometers commonly work by detecting the difference in magnetic field of earth and accurately measuring the magnetic field of a specific reference we set prior to the flight. In this way it provides the perfect orientation of the drone. All drones must have some method of measuring heading accurately in order to be able to complete a mission safely. Usually this heading information is supplied by a magnetometer and supported by the gyroscope.

Most flight controllers have an IMU (inertial measurement unit). As previously mentioned an IMU mainly consists of a gyroscope and an accelerometer. Gyroscopes are responsible for stabilizing the drone when subjected to external forces such as wind. Wind can affect the drone's roll, pitch and yaw positions making it difficult to control. However, the gyroscope can instantly detect the changes in the position of the drone caused by external forces and compensates for it so that the drone seems unaffected. Most gyroscopes used today in drone technology operate around three axes. Specifically, it measures the rotation rate around each of three (roll, pitch and yaw) axes. In other words, the gyroscope will continuously give zero readings as long there is no rotation around the axes.

Many sources mention a six-axis (6DOF) 'gyroscope', however this is a misinterpretation since there are only three possible axes for a gyroscope to measure. This misinterpretation came to rise when many FPV drone users decided to disable the accelerometer sensor on their IMU to free up processing

power on the flight controller. Gradually, IMU's were being referred to as 'gyroscopes'. This brings us to the correct interpretation of the six-axis IMU. This refers to a three-axis gyroscope and a three-axis accelerometer.

An accelerometer's function is to determine the orientation and position of the drone relative to earth's surface. This is done by sensing the acceleration of gravity, including the direction of the gravitational force. Accordingly, in a three-axis accelerometer the sensor compensates for any displacement caused by external factors and reorients the drone to the original position. Utilizing the six-axis IMU diminishes the chances of interference from wind affecting the drone's position. Also, it helps in case the drone is too high and needs to be lowered, or if it tumbles (upside down) it helps the drone to reposition to an upright position; this is done by applying throttle and centralizing other controls.

As far as peripherals go when it comes to flight controllers and drone technology, there is a wide range to choose from. LED strips can be useful to maintain visual on the drone in the dark and to maintain orientation when flying in line of sight. They can also be used as status indicators. The downside to the LED strip is that it would decrease battery life.

Another popular peripheral of choice is a buzzer. The buzzer has a range of uses. One of the useful features is if it is used as an indicator for certain procedures and statuses. It can indicate when the battery is low, when sensor calibration is complete, when the drone is armed/disarmed, and this is only some of the indicators it can be used for. Moreover, it can be used to find the drone in case it falls or crashes in an area where it would be hard to find like trees or bushes.

Last but not least, the ultrasonic sensor is another popular peripheral that can be used. Ultrasonic sensors can be very useful due to all the applications they can be used for. They can be used to measure distances between the drone and objects around it, for object detection/avoidance which can help avoid collisions, and sometimes placed underneath the drone to help execute precise and safe landings.

The motions of a drone are a result of correct functioning of the flight controller. A flight controller manages each motor individually with the aid of the ESC, resulting in the different types of motion of a drone. While doing so, it provides the capabilities to receive information from the RC transmitter through our RC receiver which enables us to control the drone and maneuver it.

3.2.2.1 Flight Controller Firmware

Flight controllers require firmware to take in all of the sensor data and generate useful control signals for the ESC's to relay to the motors. These firmwares use a

flight control loop to counteract external factors such as wind, drift, etc. Additionally, these flight control loops provide the drone the ability to maintain altitude, correct position, and provide controls to the pilot. Below is an illustration of a flight control loop that shows the integration of the flight controller, sensors, and the software algorithms to achieve these goals.

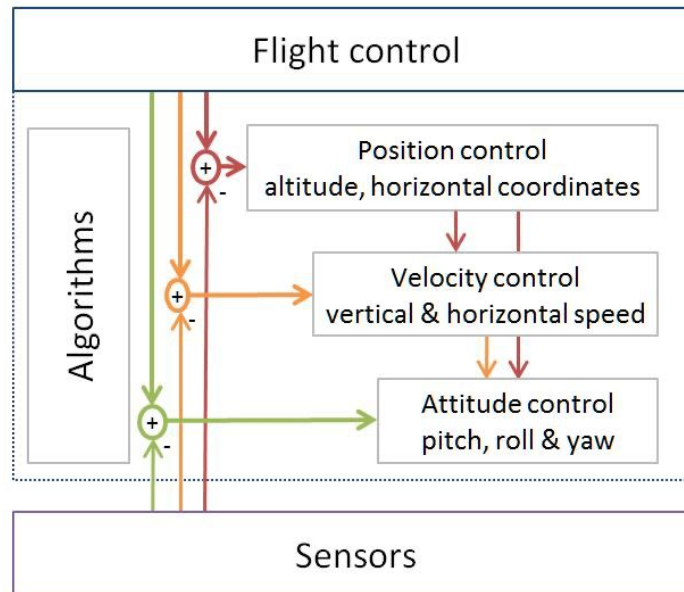

Figure 3.4: Flight Controller Loop Depiction [56]

Ten years is a long time, especially for software. But flight controller firmwares have proven to stand the test of time with some of the earliest examples released before 2010. During these years of development flight controller firmwares found their way into two distinct niches. Today there are firmwares specific to autopilot functionality and firmwares specific to racing applications. The differences lay within the features and focus of the development of each type. The autopilot firmwares tend to be used for surveying type drones that need the ability to autonomously route themselves to way points. On the other hand, the race firmwares are more hands on. They focus on providing point of view flying to the pilots through front mounted cameras and pilot worn goggles. This allows for easy transmission of video feed being supported at a software level, providing better integration of hardware components. It is worth noting that both of these types of firmwares also lend themselves to general flight as well. The mentioned features barely scratch the surface of what these flight controller firmware are capable of. These firmwares' plethora of features is largely attributed to their development architecture. Almost every major firmware in the community is based on open source software principles. Open source software means these firmwares are free and modifiable by the community. This provides the ability to see the source code and tweak certain aspects of the software as needed.

There are many flight control firmwares that exist:

- ArduCopter
- OpenPilot
- PX4
- Paparazzi
- MultiWii
- Betaflight
- Cleanflight

Due to the open source nature of these projects many of them are now the basis for other more advanced firmwares. For instance, MultiWii was developed in 2011 and used the accelerometers and gyroscopes from the Nintendo Wii remote controller. MultiWii would later go on to be the development foundation for almost every modern racing drone firmware to date.

3.2.3 Transmission Technologies

To communicate between the drone and the pilot, we need to have a way to transmit the data. In order to do this, a transmitter and receiver combination is utilized which connect to each other and then transmit the data between them. For transmitting information and data between the drone and the pilot, there are several different technologies that can be used. Each technology has the same key characteristics of a frequency range that the technology uses to transmit the signal, a distance that the signal can travel without failure, and an antenna that transmits and receives signals from each other.

A significant difference between the technologies is the frequency that they utilize to transmit the data from the transmitter to the receiver. The frequency also has a large impact on the distance that the signal will be able to travel without the signal losing power and weakening until it is unable to reach the other end of the transmission. Of all of the frequencies, the frequencies with the longer wavelengths are able to travel the longest distances compared to the frequencies with shorter wavelengths. This means that the lower the frequency is, the farther the signal will be able to travel. However, the longer the wavelength is, the less data will be able to be transmitted over the signal at one time. So while the signal will be able to travel a farther distance, it will not be able to transmit the same amount of data at the same time. That is a reason for having technologies that have a similar range of frequencies so it is consistent.

If the technologies are using the same range of frequencies within the technology, how are they able to assist in combating interference? One way that they are able to help against interference is the use of changing the frequency of the device ever so often so the frequency is not the same. If you take all of the frequencies that the hardware is changing to within the range, the average frequency will be what the range is characterized. For example, if you take the

range 5.725 GHz - 5.875 GHz, you will end up with the frequency of 5.8 GHz since it is in the center of the range that you are using.

Different technologies can also be affected differently by interference. Interference is when the signal is disrupted by an outside object or signal. For example, a Wi-Fi signal can experience interference if there are a significant amount of other Wi-Fi sources within the same area. If the sources are using the same frequency then the signals can experience delays, loss of signal, or even one signal can take over the second one and the receiver for the second signal will receive the first signal. A second cause of interference can be buildings or environmental factors such as clouds, rain, or trees. Buildings can cause a signal to reflect off of the services of the building and that can redirect the signal to a different area than where the receiver is. Signals can also have a difficult time penetrating the building, which is a reason for losing a mobile phone signal when in certain stores or buildings. The signal is unable to reach its receiver since the signal is not strong enough to get through the materials that the building is created out of.

Interference – Co-Channel Distortion

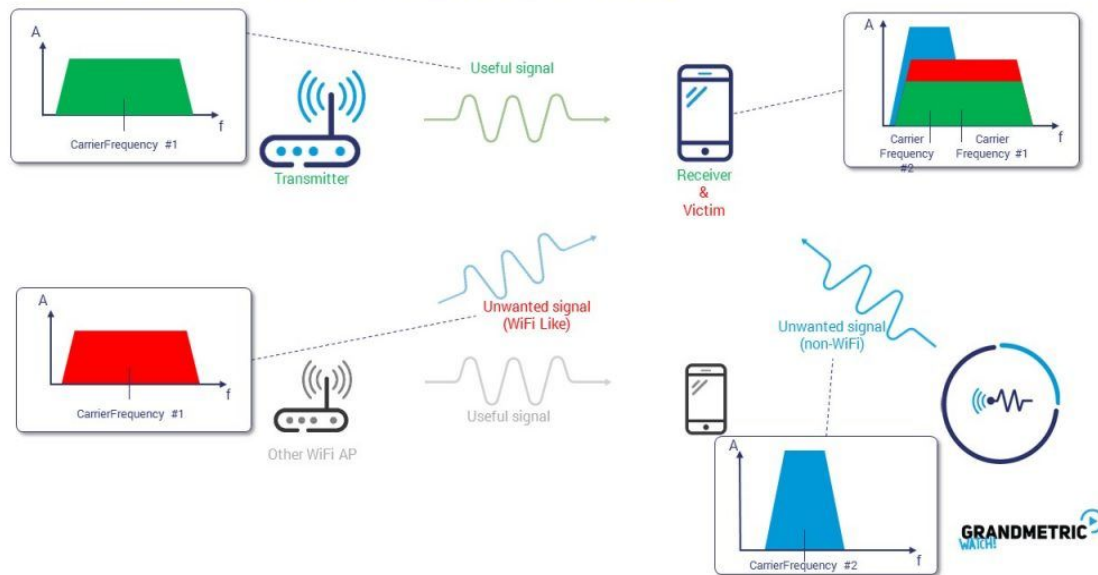

Figure 3.5: Example of Channel Interference by Same Frequency (Permission Granted to Reproduce)

To receive interference, there could be several weaker sources of signals also instead of just one other source of a stronger signal. The two different types of interference are called non-dominant and dominant.^[1] The dominant type of interference is easier to solve since there is only one source so you can just change the frequency that you are using to be different than the one that was causing the interference. Non-dominant is a little more difficult to solve since

there are multiple sources so if you change the frequency you are using then you might just change the frequency to one that another source is using.

Interference – Dominant vs Non-Dominant Interferers

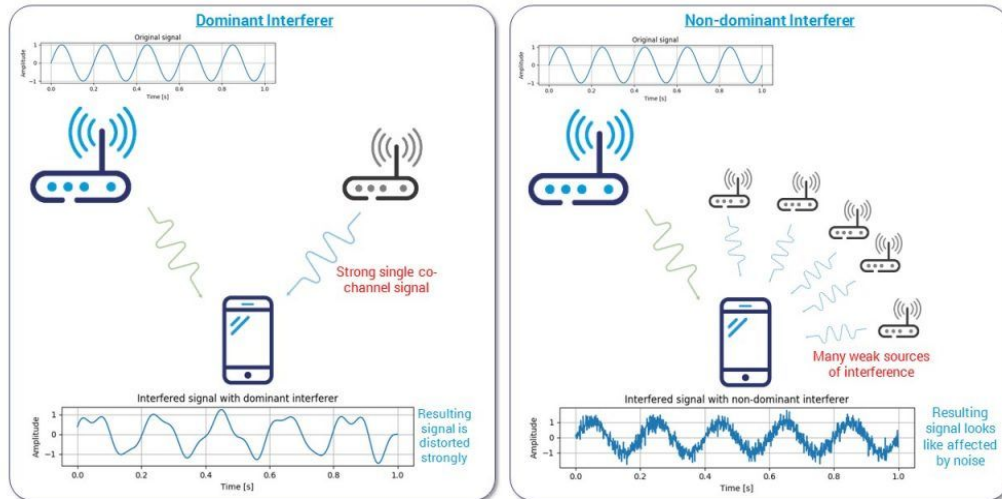

Figure 3.6: Dominant vs. Non-Dominant Interferences (Permission Granted to Reproduce)

3.2.4 Receivers and Transmitters

A receiver is used for receiving radio frequency waves sent with a transmitter which will command the ESC for different operation by altering the motor speed of each propeller.

The use of Internet of Things as a source to control the drone using smartphones using a WI-FI module chip would be one of the most efficient ways to implement communication as this would cut off a very hefty amount of the controller and the receiver. and it would not only lower the manufacturing cost of the drone but would also help to strengthen the purchase ability of the consumer.

Another important thing is that the mobile application synced with a WI-FI module chip is a user-friendly open platform software. It would give access to any user located in any part of the world compatible with any built-in smartphone software. Instead of taking several days and getting a thorough insight of the functionalities for operating the drone on a multi-button transmitter a layman would easily be able to operate the drone on his/her smartphones with the choice of positioning the controls on the screen wherever they want.

3.2.5 Motors

Motors convert electrical energy to mechanical energy. The resulting motion and torque drives the load. The load in our case would be the propellers. There are

two common types of DC motors used in drones; brushed and brushless. The varying differences between the two motors determine the type of drones it is used on.

In the beginnings of our research, we noticed that brushless motors seem to be the favorite choice of use for quadcopter drones, but its counterpart, brushed motors, is also commonly used along with being the cheaper option. Being the cheaper option and with our focus on staying below budget, brushed motors became our initial preference until we delved more into the differences between the two motor types.

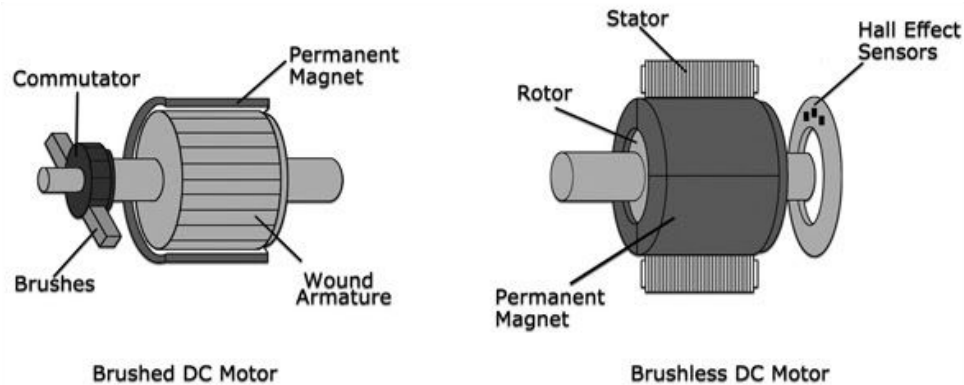

Figure 3.7: Brushed and Brushless DC Motor Comparisons (Permission Granted to Reproduce)

The brushed motor is the typical DC motor that involves a permanent set of magnets on the outside and a spinning armature on the inside. The stationary set of permanent magnets is called the stator and provides a constant magnetic field. The armature that rotates is called the rotor. The armature contains the coil wire windings around a metal core, creating an electromagnet. The wire ends are connected to the commutator. Each armature coil is energized through the commutator ring by the brushes that are connected to the power supply. The resulting current through the coils induces an electromagnetic force that makes the coils rotate. The brushes and commutator work together to continuously “flip the electric field” to keep the armature spinning.

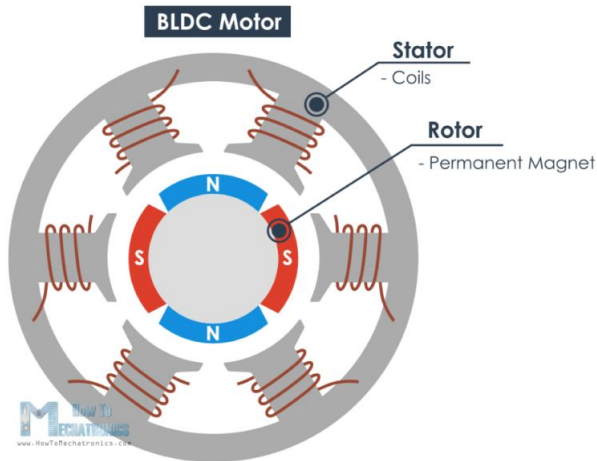

Figure 3.8: Front View of a BLDC Motor Rotor and Stator (Permission Granted to Reproduce)

Brushless motors eliminate the use of brushes and turn the motor “inside out” in comparison to brushed motors. In brushless DC motors (BLDC), electromagnets are located on the stator and the permanent set of magnets are located on the rotor. Applying current through the coils will generate a magnetic field which will either attract or repel the rotors permanent magnets. The motor controller will sense the rotors position, via a hall effect sensor or a similar device, and handle the timing and phase of the coils to keep the rotors spinning.

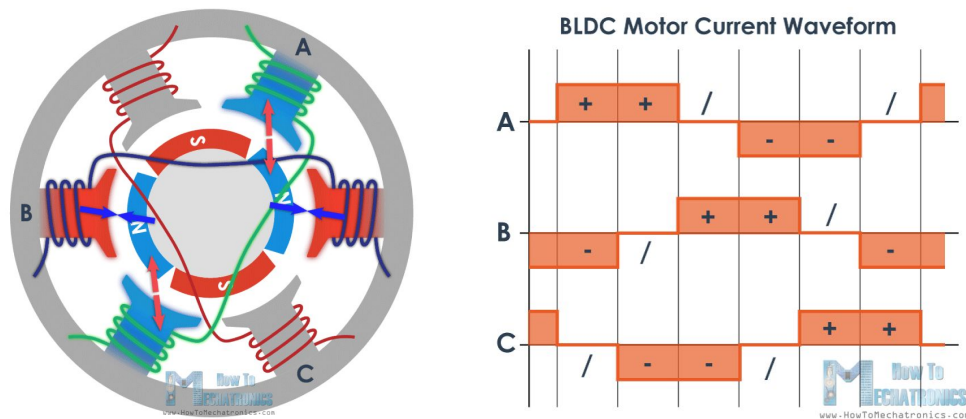

Figure 3.9: 6 Coil Configuration with Corresponding Current Waveform (Permission Granted to Reproduce)

The above figure is an example configuration of a BLDC motor and its waveform intervals that makes the rotor do a full 360 cycle. This involves energizing the coils in a way that both attracts and repels the rotor, increasing efficiency ^[60].

Brushed motors low initial cost, and simple control of speed may make it seem like a compelling choice over brushless motors but this becomes less apparent in terms of long term reliability. There is a spring that applies constant pressure onto the brushes as it shortens due to perpetual contact with the commutator and

will eventually need to be replaced. Brushed motors come with a high degree of maintenance in the long run which is not ideal. Brushed motors are also less efficient as they are constantly creating and breaking inductive circuits. This also causes a lot of Electromagnetic Interference (EMI). Since brushless motors have no brushes to wear out, they have lower maintenance and longer durability. Brushless motors are also more efficient, 85-90%, compared to brushed motors 75-85%.

Along with generating more power, being smaller and lighter, having wider speed ranges, low electrical noise and better heat dissipation, brushless motors solve many of the limitations brushed motors have and this is worth the price difference. The use of brushless motors for our quadcopter drone is an easy choice. The next question of which brushless motor we should use is not.

Owing to the fact that brushless DC motors have a higher thrust to weight ratio, they are used in most drones throughout the world. The system of drones operates by separately adjusting the speed of each motor at four ends for the specific type of motion from the three previously discussed.

The variation in the motors produces rotation, torque and thrust for the drone. Each motor's commutator is controlled electronically through speed controllers. For the specifications of Brushless DC motor, we use current and Kv ratings. This is the main criteria for selecting a motor.

The max current drawn by the motor is represented by current rating while the relation between voltage and rpm of motor is represented by Kv rating. The torque determination can also be used through Kv rating.

3.2.6 Propellers

Propellers spin and cut through the air directing it in a downward direction. This displaced air is what generates lift giving a drone the ability to lift off the ground. Additionally, the propellers are also responsible for all other aerial maneuvers as they generate thrust. Thrust is what allows the drone to move in any given direction. In aerial drones propellers are often driven by brushless DC motors. These DC motors are driven at different speeds and directions in order to perform the previously mentioned aerial maneuvers. Without propellers aerial drones would not be very aerial, therefore the right propeller design is a critical aspect of engineering a drone.

Propellers seem to be simple devices, but there are actually many engineering parameters to consider. There are two formats manufacturers use:

L x P x P or LLPP x B

L - length, P - pitch, B - number of blades

A 6 x 4.5 (also known as 6045) propellers are 6 inch long with a 4.5 inch pitch.

Other factors in choosing a propeller is the material shape. These defining properties of a propeller are considered below.

Material: There are two common materials for propellers plastic and carbon fiber. Plastic is cheap and flexible, but due to this flexibility can vibrate under load causing inconsistencies in lift and thrust. While this loss of efficiency is a negative the advantage is the flexibility makes them harder to break upon impact. Carbon fiber propellers on the other hand are much more rigid and expensive. This rigidity creates a consistent, efficient thrust at the tradeoff of being expensive. Contrast to the flexibility of plastic blades, carbon fiber blades break much easier.



Figure 3.10: Carbon Fiber Propellers

Shape: There are two prevalent shapes for propellers tapered tip and bullnose tip. Tapered noses are identified by the decrease in width to a point from the base to the edge of the propellor blade. This taper creates a lighter propeller that requires less torque to spin. In addition to needing less torque they also generate less lift and thrust because of their smaller surface area. One of the major benefits of tapered tips is the stability they provide. By reducing mass further away from the hub of the motor, tapered tips take advantage of rotational inertia. On the other hand bullnose tips do not taper down their lengths. They instead have a constant width profile that has either a flat tip of slightly angled tip. This more lift comes at the cost of more mass further away from the hub causing more load and higher amperage draw. But by having these wider profiles they can aid in quick aerial maneuvers by providing extra braking force.

Pitch: One of the most important factors when it comes to prop selection is the pitch of the prop. Prop pitch is dependent on the pitch angle or how flat the propeller cuts through the air. In the case of a very flat pitch angle, the prop will slice through the air with relatively low resistance in turn generating very little lift.

Additionally, the lower pitched props will provide more torque and responsiveness, albeit at low top speeds. As the pitch angle increases the resistance of the air becomes greater as more is pushed, generating more lift. In contrast to the low pitched props, larger pitch angles result in low torque, high top speed drones. Eventually there is a point of diminishing returns as too much of angle will not be beneficial to the downward push of air, instead pushing air to the sides. The measurement for pitch is done in distance traveled per one rotation and a common sizing is between 4 and 4.5 inches of pitch.



Figure 3.11: Different prop pitches (Permission Requested to Reproduce) [64]

Diameter: The measurement of propellers is measured in diameter from one blade tip to the other. Similarly to prop pitch, the diameter will affect the lift, thrust, and load characteristics on the motor. A smaller diameter prop will spin faster but generate less lift and thrust. The converse is true for larger diameter props. The larger the prop, the harder it is to spin.

Blade Count: The number of propeller blades for drones is a choice that can be made for even cheaper commercially available drones. By changing the number of blades on a propellor more lift can be generated. The tradeoff is however weight and load. The more blades pushing air the more air resistance the propellers will fight against. When increasing the forces on the propellers the motor load will increase causing reduced battery life. However, this increased lift can outweigh the disadvantages based on the required application. An interesting finding is that although it is hard to find 6 blade propellers sold, this blade count is considered the point of diminishing returns as far as weight is concerned.

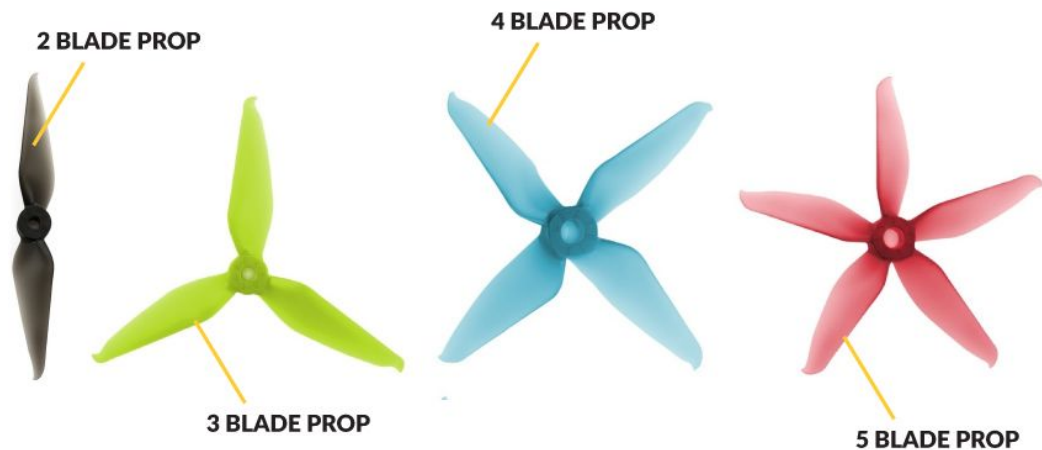

Figure 3.12: Different Prop Blade Amounts (Permission Requested to Reproduce) [64]

3.2.7 Electronic Speed Controller (ESC)

Most drones utilize brushless motors that require three control signal wires unlike their brushed counterparts. Electronic speed controllers (ESCs) are the middleware between the receiver and the motors that generate these control signals. Each motor requires its own electronic speed controller as the ESC is responsible for determining many parameters of the motor's operations. The electronic speed controller will determine how fast the motor spins, voltage, and the direction the motor spins. The ESC will be connected directly to the battery. They consist of Two main functions known as battery Eliminator Circuit which is used by connecting them to motors and receivers to a PDB in order to be used in harmony for a smooth flight operation. The ESC creates a three-phase power supply to the brushless motor using the DC input voltage it gets.

Electronic speed controllers receive the signals through the flight board and send the right amount of current required to the motors which in turn produces the correct amount of thrust for the drone. The specific amount of thrust produced from different propellers causes different types of motion which include rotation, pitch and yaw. PWM signals are given for the ESC of each motor which in turn alters the speed of each motor as desired.

The ESC provides these functionalities via an array of MOSFETs. These mosfets are what the ESC drives in order to induce magnetic fields within the brushless motors strators, allowing it to spin. This array of MOSFETS needs to be precisely timed. The precise timing requirement is why ESCs have their own integrated microcontroller. By using either Hall Effect sensors or Backfeed EMF the microcontroller can measure at what point in a full rotation the brushless motor is currently at. This gives the ability for the ESC to command the array of MOSFETs in a dynamic way, such as relying on external inputs like throttle. This

process is depicted below. The strators within the brushless motor are represented by the A, B, and C poles on the right. The middle is the MOSFET array and gives a better understanding of how timing comes into effect. The leftmost side is the MCU, driving, and sensing circuitry block diagram.

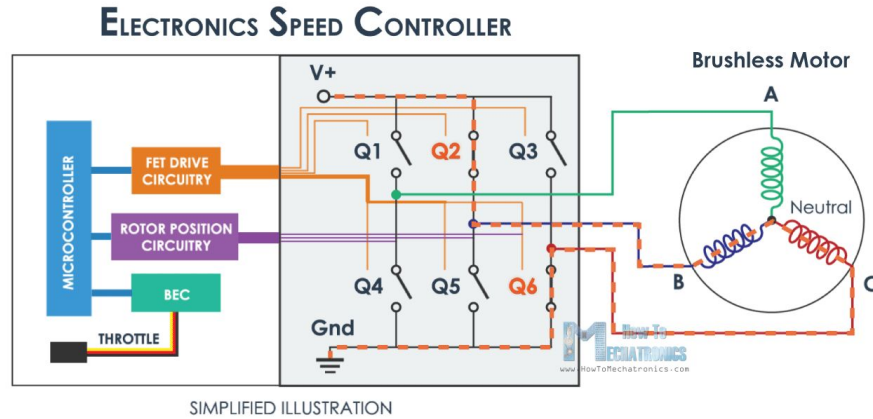

Figure 3.13: Electronic Speed Controller Internal Workings (Permission Requested to Reproduce) [60]

Electronic speed controllers today have a set of important features that are commonly marketed. Power rating, weight, size, form factor, and firmware are all part of this feature set. Additionally, all of these features carry weight in what might make one ESC more suitable than another for a given application. Therefore, each of these features will be evaluated further to get a better understanding of ESCs.

Power Rating: Like all electronic components power ratings are very important, but it is especially important when the intended load is high, such as a motor. Each ESC has a rating for its maximum current draw. Normally the maximum current drawn by the motor is less than the ESC rating of current for that specific motor. The current cannot exceed the ESC limit otherwise there will be overheating issues causing damage to the motor as well as ESC.

Weight & Size: Weight and size of an ESC are primarily based on the rated maximum current draw. The more current an ESC can handle the more heat it should be able to dissipate, in turn causing it to be larger and weigh more.

Form Factor: There are two form factors of ESCs commonly found today. The first of which is a standalone ESC that will work with one motor. The second type is an all in one ESC that will have 4, 6, or even 8 ESCs integrated on one circuit board. These all in one boards are useful for keeping projects clean and trimming down on weight, but have a major cost drawback. Unlike standalone ESCs that can be easily replaced upon failure, all in one ESCs do not have the same benefits of modularity. If one ESC on the all in one board gets fried there is very

little chance at fixing the board. Because of this many drone hobbyists do not use all in one ESCs, but choose to stick to standalones due to cost of replacement.

Firmware: Due to their onboard microcontroller an ESC needs firmware to operate. Originally this firmware was in the form of BLheli, SimonK and KISS a few popular open source and closed source options. But as time went on the open source options turned closed source and required royalties for ESC manufacturers to use. Communication protocols like PWM control were also commonplace, but as microcontrollers became more advanced more features were warranted. When 32 bit microcontrollers became readily available the firmwares had to change to support the new technology. With this change came updates in protocol that the previous 8 bit predecessors could not keep up with. These changes were in the form of protocols being updated from just basic PWM to newer protocols like DShot, OneShot, and MultiShot. These new protocols reduce response times from roughly 2ms to as little as 15us.



Figure 3.14: Electronic Speed Controller (Permission Requested to Reproduce) [65]

3.2.8 Lithium Polymer Batteries

Every electronic system requires some form of power source and in a vast majority of today's cordless consumer electronics this power source is in the form of lithium chemistry batteries. Unless specifically differentiated, lithium polymer and lithium ion batteries are often wrongly used as interchangeable terms. As far as the chemistry of each goes, they are both highly similar with one major difference being the electrolyte in between the electrodes. In regards to the lithium ion battery a liquid based electrolyte is used. In order to get the most energy density as well as counteract vibrations, heat expansion, etc. the liquid electrolyte is manufactured by encasement in a metal cylindrical shell. By manufacturing the lithium ion batteries in this fashion production costs go down, but engineers are left working around the weight of the metal casing and shape, especially in small or portable products. Although the lithium ion battery has weight and size working against it, there are many desirable qualities that make

them a great choice as a power source. For instance, lithium ion batteries do not suffer from what is known as the memory effect. Further, their energy density is one of the highest out of all the currently available battery technologies allowing it to be used in high discharge applications.



Figure 3.15: Lithium Ion Example 1

Unlike the lithium ion battery, lithium polymer batteries are manufactured either with a solid or semi-solid (gel) electrolyte. Today the solid electrolyte is not very common and most designs feature the latter gel based electrolyte. So far the lithium polymer battery has not had any major successes in its manufacturing process, resulting in LiPo technology costing more to manufacture. Even with this shortcoming gel based electrolytes provide the lithium ion battery its key advantage and reason why it is so widely used in many of today's products, malleability. This semi-solid gel has the ability to be shaped into almost any shape a designer might need. In laptops, phones, tablets, and just about every other razor thin device the lithium polymer battery takes shape as a long thin rectangle. Furthermore, the lithium polymer battery shares much of its chemistry with lithium ion batteries allowing it to also have a high energy density, albeit lower than its counterpart.

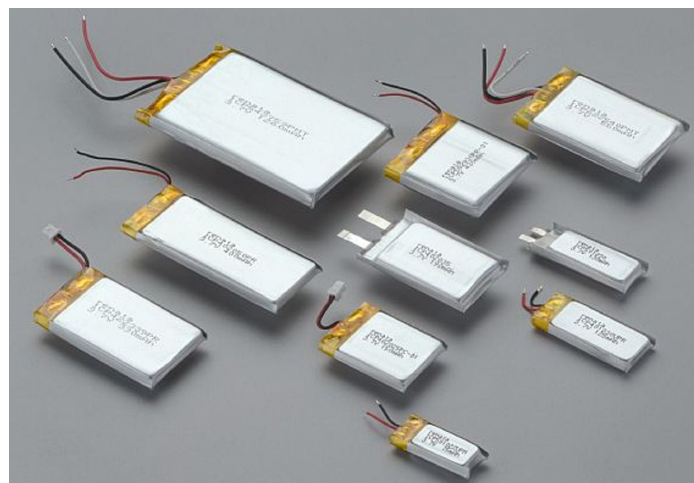

Figure 3.16: Lithium Ion Example 2

So where does this leave drones? Unanimously lithium polymer chemistry batteries have been the go to. The choice is rooted in the history of remote control vehicles, but other than history there are beneficial engineering attributes that make the lithium polymer batteries desirable. These attributes consist of dimension, energy density, voltage per cell, and discharge rate. In regards to dimension the lithium polymer battery can be molded into more shapes than its counterpart the lithium ion battery. The shape in particular that is beneficial to drones is the flat rectangle shape of the cells. This cell shape is easier to physically integrate and ends up weighing less than a lithium ion battery. The de facto quadcopter design implements four motors. Generating lift is and maintaining altitude for extended periods of time is a very energy draining. Additionally, motors are historically power hungry components and require a power source that can keep them running long enough to provide useful work.



Figure 3.17: Li-Ion vs. Li-Po (Permission Requested to Reproduce) [66]

The most common method to power the drones having relatively small sizes includes Lithium-polymer batteries. Lithium-polymer batteries power small electrical brushless DC motors which are attached to each end to propellers separately.

These batteries' requirements for drones include high energy /weight ratio. It gives the advantage for decreasing the overall weight of the drone which in turn makes it easier to provide thrust and less energy is required to operate the drone.

These batteries have high discharge rates ranging from five minutes to two hours. These batteries are independent of shock and vibration, which decreases the vibration in the drone, providing a smooth ride.

These batteries also provide fuel grading which mentions the real time battery percentage monitoring. The fuel grade is critical in drone flights as the flight depends mainly on the battery and higher the battery percentage higher leverage for its functionality.

Power supply in drones should be carefully engineered due to the hazard of being environmentally hazardous materials in batteries and the liability of battery rupture causing serious damage to the drone. If the load on batteries increases past the safety limit, the temperature of Lithium batteries increases and thermal runaway continues. As a result, the flammable gases from the battery materials which also includes the organic electrolytes starts to accumulate in the battery causing the rupture of battery.

The battery packs are protected by a safety circuitry which protects the battery with a rapping of plastic or PVC wrapper. The plastic covering protects the battery from external metal contact which provides safety from accidents.

Lithium Polymer (LiPo) batteries have higher capacities and low weights. One cell of a LiPo battery provides 3.7 volts. So by combining several cells in series and parallel combinations, desired voltage and desired charge capacities can be achieved.

The C-rating of the battery is also considered that tells us about the rate at which the battery is discharged. For 12kg payload, 20000mAH 6s battery is used. The number of cells used are directly proportional to the power supplied to the drone. For an average drone six cells i.e. 22.2V battery is used.

3.2.9 3D Printing

3D printing is an additive type of manufacturing that has been getting more popular over the years, in the industrial, commercial, and hobbyist markets. 3D printing involves modeling the object in CAD allowing the creation of complex shapes and geometries that traditional subtractive manufacturing can not. It is often used as a form of rapid prototyping and in most cases considered a synonym for 3D printing in the industry. Obtaining a competitive advantage in a fast paced industry can come down to the speed of innovation and 3D printing is a perfect catalyst to do that.

In the drone community, 3D printing is a core aspect that made builds cheaper and more accessible to the average consumer. CAD models of frame parts or

mounts are created and shared freely online for the rest of the community to use. 3D printing services are also experiencing rapid growth due to manufacturing and consumer needs. Not everyone has their own personal 3D printer, but anyone can create a 3D CAD model since there are many free CAD software. In our project, we will utilize SolidWorks 2019 Student Edition provided by UCF.

Advancements in 3D printing are present not only in techniques but also in the materials used. These days, 3D printing with metal is used frequently for parts in the space industry and even engines in exotic cars. A 3D printed community made from concrete was recently under construction in Mexico. Printing with plastic is no longer the limit. The prime of 3D printing has occurred since 2011, and as investment and interest rise, it will continue to advance for the foreseeable future.

3.2.9.1 ABS vs PLA

ABS (Acrylonitrile Butadiene Styrene) and PLA (Polylactic Acid) are the two most common Fused Deposition Modeling (FDM) desktop printing materials. As thermoplastics, they enter their moldable states when heated, and return to a solid when cooled. The following table compares the main printing properties of both materials.

Properties	ABS	PLA
Printing Temperature	210-250°C	180-230°C
Print Bed Temperature	80-110°C	20-60°C
Print Bed	Mandatory	Optional
Enclosure	Optional	Recommended
Clogs/Jams Nozzle	Occasionally	Never
First Layer Adhesion	Minor problems	Minor problems
Fumes	Little to none	Band and intense
Absorbs Moisture	Yes	Yes
Spool Price	\$21.99	\$22.99

Table 3.2: ABS and PLA Printing Properties [67]

PLA printers at a lower temperature and is less likely to warp. The final product will generally look better than its ABS counterpart while also being easier to print for beginners. PLA's stiff characteristic is met by its brittle nature. ABS is a lighter material that boasts a slightly higher strength, flexibility and durability. It is more

weatherproof and does not deteriorate as easily as PLA. but it is more difficult to print.

In regards to 3D printing drone parts, either material should suffice. In our case, the decision of which material to choose comes down to our accessibility to 3D printers that uses either material.

Some components of the drone that we will be 3D printing include:

- Motor mounts
- Landing gear
- Camera mount
- Antenna holder
- Battery pack casing

3.2.10 Power Distribution Boards

In order to power the numerous components that are in a drone the power source, most often a LiPo battery, must be distributed and regulated. This is commonly accomplished via a PDB or power distribution board. These boards allow for a cleaner overall drone as they centralize the wiring away from the power source and usually in a circular distribution. Additionally, some boards are manufactured with voltage regulators in a buck configuration that can provide a constant 12v or 5v output. These bucked voltages are useful for on board transmitters, cameras, LEDs, etc. as they cannot run off the higher 14.8v output from 4 series cell LiPo batteries. An example of a basic power distribution board is shown below.

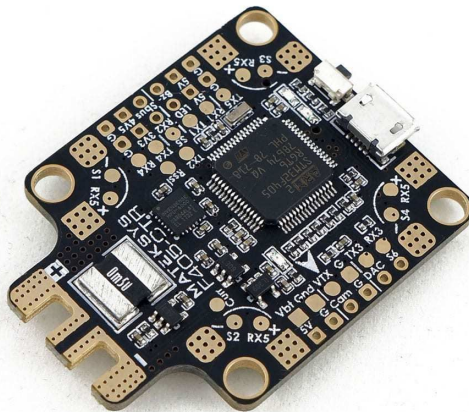

Figure 3.18: Power Distribution Board with FC (Permission Requested to Reproduce) [68]

3.2.11 Cameras

In order for object detection software to function, it needs to have some sort of input that the program can analyze for the object it is trained to detect. For our project, the input that we are going to use is a camera that is attached to the drone and then transmits the video signal to the pilot on the ground. Someone may think that any camera would be able to be used for a case like this but that is not true. To achieve a more accurate detection rate, the camera that is used should have a higher resolution which aids in the object to be detected from a greater distance away.

Now what does a camera's resolution mean? A camera's resolution is "the amount of detail that the camera can capture."^[26] Resolutions are commonly measured by the number of vertical pixels in the image. For example, a resolution of 1280 x 720 pixels would be stated as a 720p resolution. There is a second measurement system that some camera manufacturers use for the resolution of their cameras. The second form of measurement is the number of horizontal pixels in the image. An example would be if a camera's picture has one thousand pixels in each horizontal row, the resolution would be stated as 1000TVL.



Figure 3.19: Resolution Comparison (Permission Requested to Reproduce)

Images with a higher resolution generally have a better accuracy for object detection.^[24] From a farther distance away, the lower resolutions will have less detail in the image and the object detection will have a decreased accuracy, which is why we desire to have a camera with a resolution of at least 720p.

Cameras commonly used on drones are designed for a first person view while piloting the drone. Those types of cameras are smaller and lighter in size compared to what someone might imagine as a camera. Some manufacturers of the first person view cameras also include a video transmitter built into the

camera. These cameras commonly have a resolution less than or equal to 1000TVL.



Figure 3.20: Camera with Built-in Transmitter (Permission Requested to Reproduce)

Other cameras that are designed to be used with photography are larger and not commonly used with drones. These cameras do not have built in transmitters but they commonly have a 720p and 1080p resolution options that we can choose from. The cameras used for photography are larger than the first person view cameras and are a little more difficult to mount onto a drone. Drone pilots will often design their own mount for a camera on their drone so they are able to use a camera with a better resolution. Some manufacturers of the cameras will also have an option to purchase a mount that is designed to fit their camera.



Figure 3.21: 3D Printed Camera Mount (Permission Requested to Reproduce)

3.2.12 Computer Vision

The computer vision aspect of our project involves identifying and counting objects that are seen by our drones overhead camera and relaying that information back to our in-house built phone application. Objects could include things like cars, people, pets, etc. It does not necessarily matter what type of object it is, as long as our computer vision program is trained and optimized to detect the object.

3.2.12.1 Object Detection

This process of identifying objects is known as object detection. Object detection is a rapidly growing subsection of computer vision. Hot topics like self driving cars, factory automation, and city functions like parking space tracking are all at the forefront of object detection. Object detection is actually composed of two separate computer vision tasks, localization and classification. Localization is the process of determining the area of the image that an object resides in or the “where”. Classification is determining the objects title or the “what” the object is.

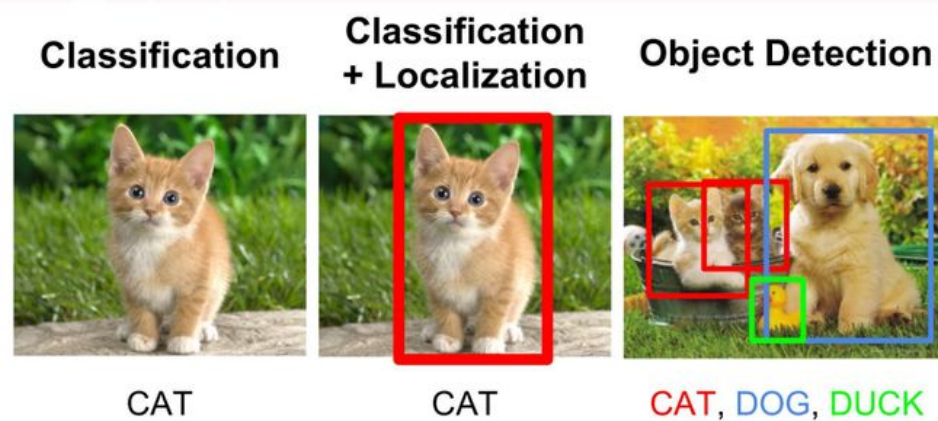

Figure 3.22: Classification [76]

Machine learning is consistently leveraged as a main paradigm for developing object detection systems. Overall, there are traditional machine learning methods and deep learning methods. Today deep learning methods are more prevalent in object detection applications as more and more require very fast computation times. The differentiation between traditional machine learning and deep learning are neural networks.

Detection can be further divided into three different types: (a) Monolithic, (b) Part-based, and (c) Shape matching. Monolithic Detection is trained by using full body appearances and as such benefits from sparse crowds. This type of detection technique cannot be applied by our system; our camera angle is positioned overhead of people and not horizontally on the level of the crowd's height. Parts-based detection is a better suite of our needs as instead of taking the entire body for the classifier, parts such as the head and shoulder are enough to detect the presence of a person. Shaped matching is similar but instead uses ellipses as the boundaries of the human body that is being detected. Part-based detection works at a steeper angle view and with denser crowds making it a good candidate method to use for our project.

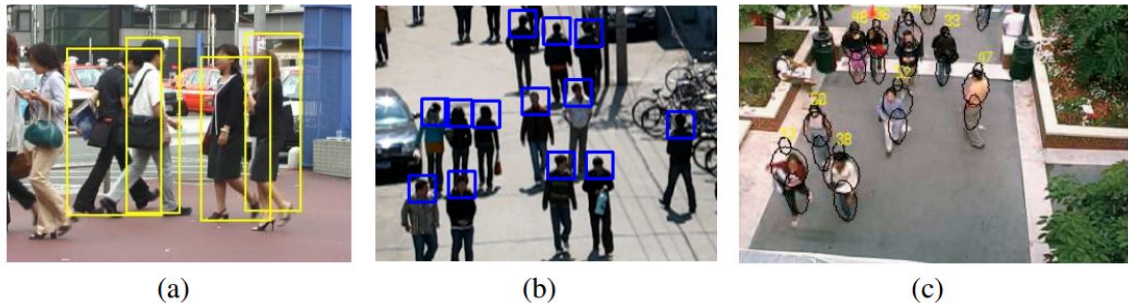

Figure 3.23: Pedestrian Detection Results Using Different Techniques

3.2.12.2 Neural Networks and Convolutional Neural Networks

Neural networks are loosely modeled after the human brain. They consist of thousands or even millions of densely connected nodes. These nodes are also referred to as perceptrons or neurons and are responsible for simple processing. These nodes each have an associated weight and are arranged in layers that compose a network. When a node receives input it will multiply it by its weight and sum the connections coming into it before checking against a threshold value. If the nodes calculation and the threshold agree, the node will feed its value forward. All of these values will eventually come down to one number, the prediction the network computed.

This process is tuned or trained in order to make the nodes calculations produce worthwhile output. In our interest of object detection, positive examples would be passed through the network. For instance if we were trying to detect a person, images of various people would be fed to the network. Each of these examples would have to be further broken down into their most prevalent features for the network to make any sense of them. Features would be handcrafted by the programmer and could include areas of interest like two eyes, a nose, and mouth. These features would actually be numerical representations that targeted specific areas of the image. Additionally, each of these examples would be labeled, such that the network would know when its predictions are correct and when its predictions are wrong. By using this information the nodes weights are adjusted until a desired output accuracy can be achieved.

Neural networks in their basic form provide a solid foundation for tweaking and innovation. In the case of object detection, researchers applied this theory to create the convolutional neural network (CNN). A convolutional neural network utilizes a convolutional layer in conjunction with the common layers of a basic neural network. Convolutional neural networks had been relatively stagnant after their creation and it was not until 2012 when a machine learning architecture called AlexNet really proved their usefulness in the field of computer vision. The key to their effectiveness lies in the convolutional layers ability to extract features

from the input image. This means that there is almost no need to hand craft features for the input examples.

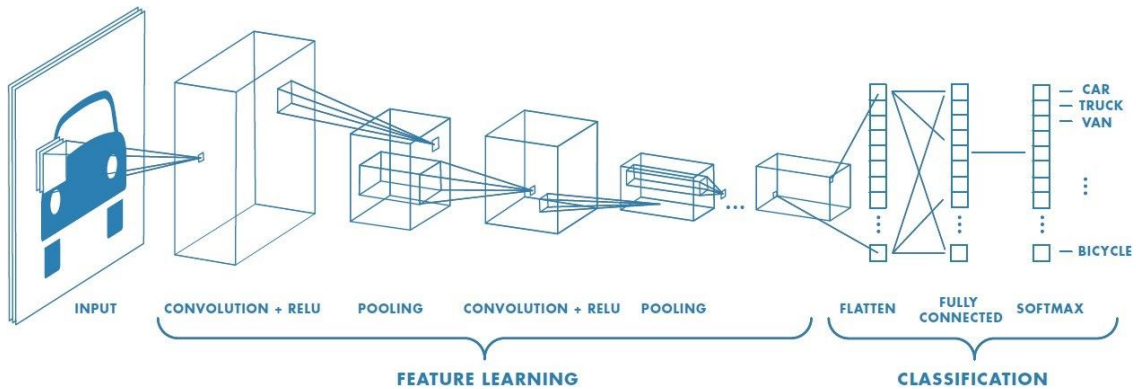

Figure 3.24: Feature Learning and Classification

Feature extraction is accomplished by using the mathematical operation of convolution. The image's pixel values are analyzed against many filters. These filters are commonly referred to as kernels and slide or step over the pixel values of an image convolving along the way. Kernels are always smaller than the image, such that the spatial information of surrounding pixel values is taken into consideration. The process of convolving the image with the kernels results in feature maps. These feature maps are what represent the extracted features and get vectorized. When the feature maps are vectorized the remaining layers can utilize the features for predictions. Below is a depiction of this process that includes the kernel in yellow, the image pixel values in green, and the resulting feature map/convolved feature in red. The yellow window will slide over the green pixel values to create the red feature map.

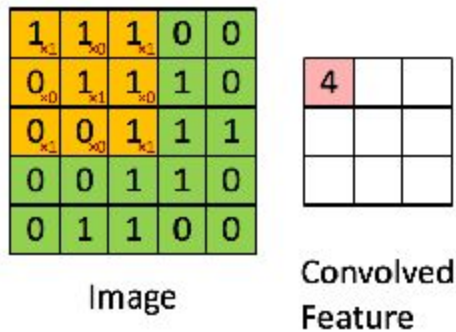

Figure 3.25: Image and Convolved Feature [77]

3.2.12.3 Algorithms & Detectors

Today object detection algorithms and network architectures are split up into two categories Two-Stage Detectors and Single-Stage Detectors. Two-Stage Detectors were first. As the name suggests the architecture of a two-stage

detector is divided into two discrete components. The first part of a two-stage detector takes the image in question as input and finds regions of interest. These regions are then proposed to the second layer as input. These inputs are then run through Convolutional Layers to extract features, before being sent to a Support Vector Machine (SVM) to classify the objects based on the extracted features. The ultimate result would be bounding boxes and classifications for each object in an image. These two stages make up the fundamental definition of object detection as both localization (*where*) and classification (*what*) are occurring. Two-stage detectors are known for having high localization and classification accuracy but suffer from slower prediction times not suitable for fast real time applications. This is the general idea of a two-stage detector and below are some examples of the most staple two-stage detector architectures. Additionally, a figure depicting a convolutional neural network (CNN) can be seen below as almost all deep learning detector architectures rely on

R-CNN

Ross Girshick *et al.* introduced the use of CNNs in object detection in 2014 with a region based CNN method named R-CNN.^[73] The R-CNN architecture is a two-stage detector and is depicted in figure 3.26. It starts with a region proposal algorithm, selective search in the case of [73], that scans the image and provides 2000 Rols. These Rols are then fed into the CNN to extract a 4096-dimensional feature vector from each region. Lastly, the feature vectors are ranked by class specific linear support vector machines (SVM). The SVMs determine the likelihood of an object in a proposed region and if an object is present its category/classification. R-CNN was tested against the PASCAL Visual Object Classes (VOC) Challenges datasets. At the time these datasets were a definitive showcase to prove object detection methods. R-CNN demonstrated a 30-point improvement in the VOC 2012 dataset over the previous leading method, scoring a 53.3% mean average precision (mAP).

A 30-point jump is very large on almost any dataset, especially in the field of object detection. Additionally, this was during a time preceded by a lull in the progress of computer vision as a whole.^[73] However, R-CNN was not without its faults. Later iterations of two-stage detectors, such as Faster R- CNN [74] will identify the region proposal stage as a speed bottleneck. Because of the 2000 proposed regions in [73], performance was only able to reach 14 secs per image even while leveraging the GPU.

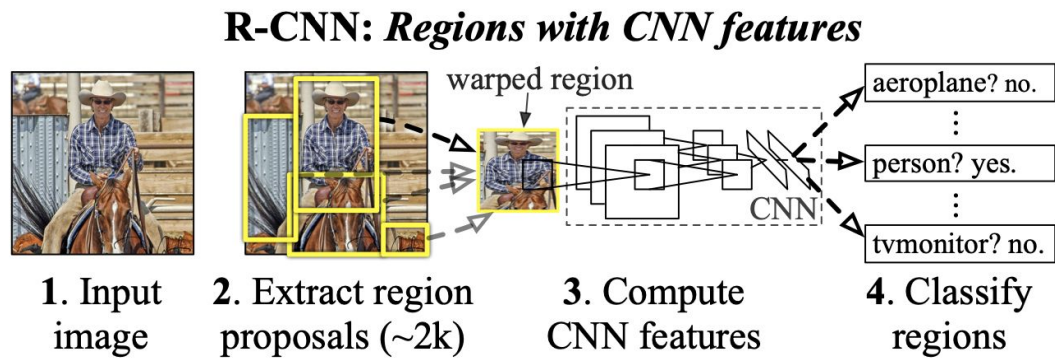

Figure 3.26: Regions with CNN features [73]

Faster R-CNN

Recognizing the slowdown of region proposal algorithms, Shaoqing Ren *et al.* implemented Faster R-CNN in 2015.^[74] Faster R-CNN is one of the newest iterations of R-CNN, implementing a more novel approach to speeding up the original method. Instead of using the Selective Search algorithm like iterations before it [73], Faster R-CNN combats the bottleneck of region proposal by creating a CNN based network called a Region Proposal Network (RPN). The region proposal network takes care of rectangular object proposals as well as objectness score (object vs background confidence). The RPN is also implemented in a way that shares convolutional layers with the base network structure of R-CNN.

With the novel implementation of region proposal as an RPN, Faster R-CNN was able to achieve a 5fps inference speed for the whole system. This speedup was making way towards real time applications for the time. Furthermore, achieving a 73.2% mAP on VOC 2007 and 70.4% on VOC 12 surpassed the accuracy of preceding iterations.^[73]

Single-Stage Detectors appeared shortly after Two-Stage Detectors and take a different approach to object detection. They still consist of more than one network layer, but they are not regarded as discrete parts. Instead these combinations of neural net layers are regarded as a whole architecture or system. The goal of Single-Stage detectors is the same as that of Two-Stage detectors. Localize the object in the input and classify it. However, the methodology eliminates the region proposal aspect by instead dividing the image into regions before using it as input. These divided sections then have bounding boxes and classifications predicted. This elimination of region proposals speeds up one-stage detectors, such that they are fast enough for real time systems. However, this speed up comes at the cost of detection and classification accuracy which lags behind that of their two-stage counterparts. Examples of the most prevalent architectures are discussed below.

YOLO

You Only Look Once (YOLO) is a one-stage detector that frames object detection as a regression problem.^[72] Developed by Joseph Redmon *et al.* in 2015 YOLO is composed of a single neural network that predicts bounding boxes and class probabilities directly from full image input. The network design consists of 24 convolutional layers followed by 2 fully connected layers. As mentioned, YOLO's input is a full image. This image is split into a $S \times S$ grid. If an object center falls within a grid cell, that grid cell will then be responsible for detecting that object. Each grid cell predicts B bounding boxes and confidence scores for the boxes. These confidence scores are related to the bounding box containing an object and the score for the accuracy of the bounding box itself. YOLO's confidence parameter is evaluated using intersection over union (IoU) between the predicted box and the ground truth. Each grid cell also has the task of predicting C conditional class probabilities, based on the condition the cell contains an object. The parameters S , B , and C are experimental and defined in [72] as 7, 2, and 20 respectively. The combination of both localization and classification into a single system allows for one evaluation per image. The result is a fast, end-to-end system architecture. YOLO exhibits real time performance far surpassing the performances of two-stage detectors. Training YOLO on PASCAL VOC 2007 and 2012, led to a mAP of 63.4% at 45fps. There are now two newer iterations of YOLO called YOLOv2 and YOLOv3. Ultimately these improvements are meant to increase the accuracy that single stage-detectors historically lacked.

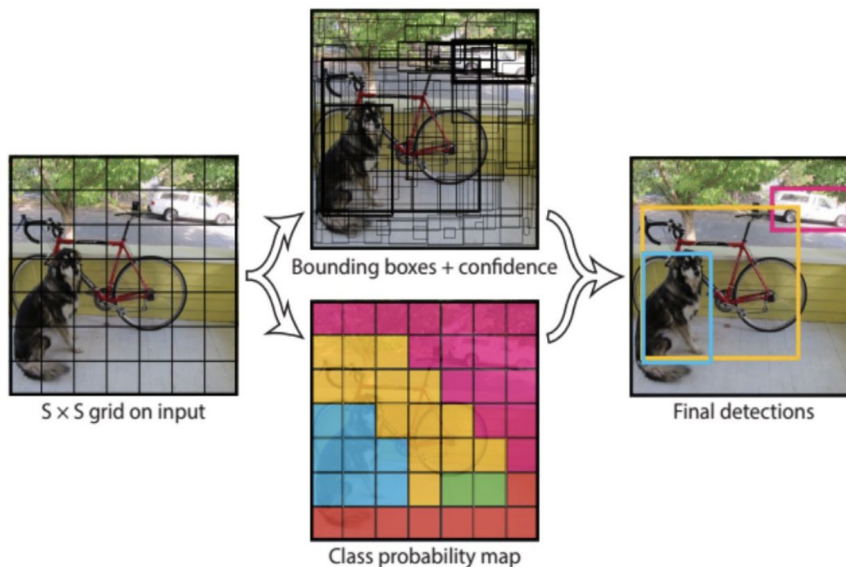

Figure 3.27: YOLO Grid Cell Example [72]

SSD

The second one-stage detector called Single Shot Multibox Detector (SSD) was introduced by Wei Liu et al. shortly after YOLO in 2015.^[71] Similar to YOLO and keeping in line with the idea of one-stage detectors, SSD consists of a single deep neural network. This deep neural network utilizes a similar structure to that of YOLO, but trades the fully connected layers for extra convolutional feature layers. A framework overview is depicted in fig. 5. The key points of the SSD method are as follows:

- **Default Bounding Boxes:** SSD utilizes default bounding boxes with different aspect ratios and scales. Each feature map cell is tiled with these bounding boxes such that they are fixed in relation. The feature map cell position is then used when predicting offsets. This process is depicted in fig. 5(b).
- **Scaled Feature Maps:** Utilizing outputs at different levels of the network provide scaled variations of the feature map. These scaled variations can then be used to make predictions for different scaled objects.

Based on the two main features above, SSD sets itself apart from YOLO. It runs detection on different scales found on different layers within the network vs a single top layer tackling the previous issues YOLO had with small scaled objects. Additionally, by using fixed default boxes the issue of object aspect ratio seen in YOLO is remedied as well. With the improvement in detecting small scale and unique aspect ratio objects comes a boost in overall accuracy. SSD achieved a mAP of 76.8% in VOC 2007 and a mAP of 74.9% in VOC 2012 both of which surpass the scores of YOLO and Faster R-CNN in the same datasets while averaging 59fps.

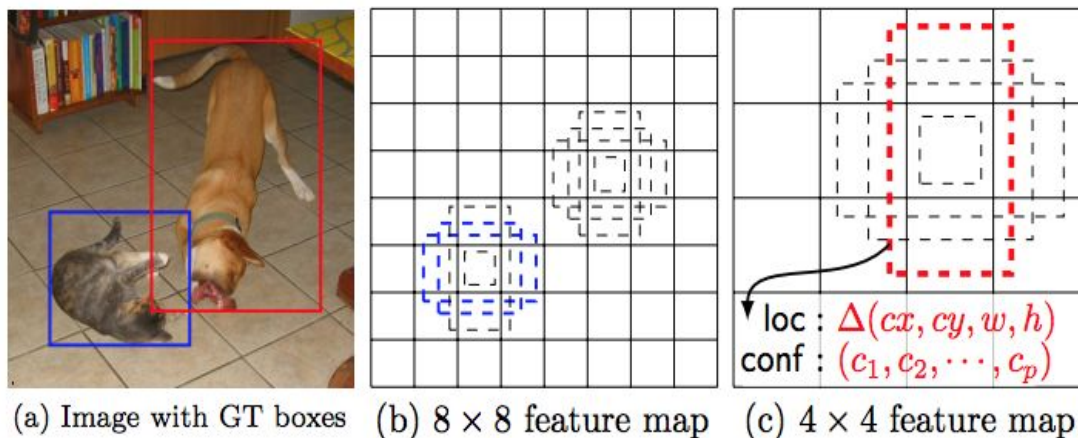

Figure 3.28: Single Shot Multibox Detector (SSD) [71]

3.2.13 Application Development

Application development can be for a multitude of platforms. Currently, software applications that interact with drones are mostly mobile based with a few notable examples running on personal computers such as desktops and laptops. As far as mobile applications go there are really only two largely supported platforms, Android and iOS.

The Android operating system gets its official applications from the Google Play Store. When searching the term drone on the Play Store a multitude of results are found ranging from games, simulators, information, and companion apps for specific store bought drones. Additionally, when searching other similar terms with object detection there does not appear to be any specific application regarded for object detection with drones.

Application development on the Android platform has a low bar of entry that allows anyone with a computer to develop for it. Almost all major operating systems, such as Windows, Linux, and Mac are supported. By having access to Android Studio, which is a free integrated development environment (IDE), a developer automatically gets access to the Android SDK. The parent language for Android development is Java, but other languages like Kotlin, Dart, and many others are now in use. In order to publish applications on the Google Play Store a developer account is needed. Google makes these developer accounts a one time payment of \$25 USD. Additionally, for smaller scale software applications android supports side loading apps. This means that the Android operating system will allow apps from third party distributions run on the device.

Apple's iOS has its own first party app store simply called the "App Store". When searching for the term drone the results are identical to the Google Play Store. Most of the options returned consist of games, simulators, information, and companion apps for specific store bought drones. Also, identically we have no specific results for object detection drone applications.

As far as development for iOS, it is a much more locked down ecosystem making development a bit more of a rigorous process. In order to develop an iOS application for a mobile Apple device a Mac with Xcode (IDE) is necessary. Similarly to developing for Android, a developer account is also a requirement for uploading to the App Store. One of the biggest barriers is that a \$100 yearly fee is necessary to acquire this Developer account. For smaller projects an iOS app can be hosted for download from third parties, thus bypassing the developer account. But these sideloaded apps are only valid for 7 days on the device.

3.2.14 Mechanism and Motion

The major operation involved in the operation of drone are as follows:

- Movement in Forward direction
- Movement in Backward direction
- Maneuvering right
- Maneuvering left
- Takeoff
- Landing

These movements are the result of a combination of different thrusts for each propeller. Variation in the propeller's speed causes variation in the thrust which in turn produces different types of motions.

In order to move forward the speed of two rotors in the front is increased relative to the two in back which causes the drone to move in forward direction. Similarly, in order to move backwards, the speed of the back two rotors is increased relative to the front two which causes the drone to move in a backward direction.

Similarly, to move in the right or left direction of the drone the speed of the right two or left two rotors is increased respectively. The movement of the rotors results in different types of motions of the drone which includes rotation around axis (pitch), movement in left and right direction (roll) and rotation in counter clockwise and clockwise direction (yaw).

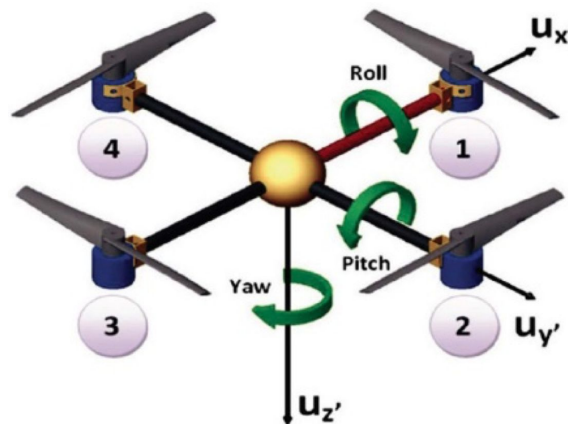

Figure 3.29: Types of Motion of a Drone

Finally, for landing, the thrust of all the propellers is decreased causing the drone to decrease its altitude and in order to lift the drone, the thrust of all the rotors is increased. The rotation of a drone about its axis is caused by varying the clockwise and counterclockwise motion of propellers.

3.3 Parts Selection

This section will describe why some of the components were selected. Each item selection is based on research, budget, and availability. The overall price summary for all the parts selected will be located in the 8.2 Budget section.



Figure 3.30: Overall Components

3.3.1 Frame Materials

The following are possible materials our drone frame can be made out of and related considerations:

- Carbon Fiber: This is the ideal material any quadcopter drone should be made out of as it provides the highest strength and lowest weight ratio but it is expensive. Carbon fiber is also known to block transmission signals so the position of any antennas should be carefully considered.
- Wood: This is the most attainable out of all the other materials. It is cheap and easy to build with. Its properties are also quite strong and light along with being Radio Frequency (RF) transparent. If made by wood, wear from extended use outside could be a factor in reducing the drone frame's longevity such as due to the expansion/ softening of wood due to humidity.

- Aluminum: This material is very attainable, cheap, and light. However, the tools necessary to build with this material could be expensive. Machinery is necessary to cut bigger pieces of aluminum into more complex forms. Additional tools are also needed when bending thin pieces of aluminum.
- Plastic & PVC: Plastic frames are usually made via 3D printing. This method of manufacturing offers customizable design structures that could be optimized for strength and lighter weight. PVC also offers customizable design as there are many PVC sizes and fitting types. Both materials are suitable to be either used for rapid prototyping or as part of the final design.

Material	Benefits	Density	UTS	Price
Balsa Wood	Sound, heat and vibration insulation	40-340 kg/m ³	1MPa	Cheap
Expanded Polypropylene	Lightweight, enhanced durability and recyclable	20-200 g/L	270 to 1930 kPa	Moderate
Aluminum	Heavier with increased strength	2710 kg/m ³	210 MPa	Cheap
Carbon Fiber	Very high strength to weight ratio	1800 kg/m ³	3.5 GPa	Expensive

Table 3.3: Different Materials and Their Properties

3.3.2 Motor and Propeller Selection

It is crucial to have the proper motor and propeller combination for the selected drone frame size of the drone. Having a motor that is too large for the propeller will be unnecessary weight, but having a motor that is too small for the propeller will have poor performance and will increase the risk of motor burning up. In general, larger propellers will need low RPM motors with high torque while smaller propellers need high RPM motors to generate equivalent thrust in an efficient manner. Larger propellers means more material to move, hence the necessity of high low end torque motors. The opposite applies for smaller propellers.

There will most likely be a better combination of motors and propellers than the combination we end up selecting but that is the case for things where there are a large variety of options. The best we could do is select the best we can based on research and availability.

A good rule to follow is to have a quadcopter that has a minimum of a 2:1 power to weight ratio. This 2:1 power to weight ratio allows for the drone to hover at half throttle which improves power efficiency. In our case, we are aiming for a 2.5:1 power to weight ratio for better control and extra room for payload in the future.

The total weight of our quadcopter will include everything from the frame, motors, propellers, battery, electronics, and camera attachments.

Since reliability and high flight times is the goal, brushless motors for a quadcopter is a no brainer. It offers greater efficiency, compared to its brushed motor counterpart, meaning that more power used by the motor is converted into rotational force instead of being lost to heat.

Knowing the type of motor we wanted to purchase, we now need to find one with enough power for our drone. When considering which motor to purchase it was helpful to have a reference for our target weight and thrust ratio. We were able to find a chart that led us to consider options that generated roughly 600 grams of thrust per motor. Additionally, this reference also mentioned a motor with roughly 2300 down to 1600 revolutions per volt or KV. This is due to the direct relation between torque and RPM. With these parameters we were able to find 3 motors that seemed to fit our criteria. The EMAX RS2205-S, iFlight 4pcs XING-E 2306, and Racerstar 2207 BR2207S.

The EMAX was chosen over the two other possible motor selections in the table below as it satisfies all the factors we need for our drone. The iFlight motor is similar to the EMAX but with a higher KV, which is unnecessary. It offers less torque in the low end and will consume more battery power as well as being more expensive. The Racestar motor was a good choice as well as its lower KV means that it can support bigger propellers for more efficient flight. It was not chosen as it was not readily available to purchase along with its recommended ESC be rated at 45A. A 45A ESC is also more expensive and not as available to purchase as a 35A rated ESC.

The EMAX RS2205-S 2300KV is the updated version of the RS2205 which was known to be fast, reliable, and durable in the drone racing community. The updated RS2205-S cranks out an additional 100g of thrust while keeping the motor height lower and being lighter for only an extra five dollars. There is also no difference between CW and CCW motors in the updated version unlike in the previous versions where the direction is specified for each motor. Reversing the motor direction can be done by simply swapping the two of the three wires that connect to the ESC or through the ESC settings. This convenient feature is one less thing to be confused about for first time quadcopter builders.



Figure 3.31: EMAX RS2205-S 2300KV

	Voltage (v)	Propeller Used	Max Thrust (grams)	Weight (grams)	Constant Velocity (Kv)	Price (USD)
EMAX RS2205-s	11.1 - 16.8 3 - 4S	HQ v1s 5X4X3	1126.49	28.8	2300	\$58.00
iFlight 4pcs XING-E 2306 2450KV	11.1 - 16.8 3 - 4S	HQ v1s 5X4X3	1379.15	33.8	2450	\$60.99
4X Racerstar 2207 BR2207S	11.1 - 22.2 3 - 6S	HQ 7042	1343	35	1600	\$51.50

Table 3.4: Motor Comparison Summary [43] - [48]

The thrust values in the table above are estimates and vary greatly, depending on the prop selection. The chosen propeller is the QProp Ethix S3 5 x 3.1 x 3 Tri-Blade Propeller. A 5 inch propeller is standard for the motor we have chosen. The low pitch of 3.1 in comparison to other standard 4 to 5 pitch propellers was an intentional decision. A lower pitch will often result in more torque and less turbulence for lifting, creating less work for the motor when carrying a heavy payload. The lower pitch of our chosen props will result in lower maximum thrust compared to what's advertised in our motor comparison table. Higher pitch propellers move more air creating higher maximum thrusts but our quadcopter does not need that. Since our drone will be mostly hovering, a lower pitch is more efficient, prolonging flight time.

3.3.3 ESC

It is important to select the proper ESC suited for our motor and propeller combination. It is generally a good idea to select an ESC that offers a current rating of 10A over the maximum current draw of our drone to avoid burnouts. Our motor and 5" propeller setup's maximum current draw is estimated to be around 25A. For bigger 6" props, current draw could go over 35A.

The 4 in 1 ESC was a good option as well but it is more than we need. It can save some complexity in wiring and weight but the 35A is more cost effective in the long run. If a 4 in 1 ESC burns out or crashes, the entire board becomes useless. This is not the case of Individual ESC's as they can be individually replaced when broken.

Taking all these into consideration, we have selected to use highlighted ESC in the table below.

ESC	Type	Current Rating (A)	Price (USD)
30A RC Brushless Motor Electric Speed Controller ESC 3A UBEC	Individual ESC	30	16.49
NIDICI BLHeli_32 Bit 35A ESC 2-5S Brushless ESC	Individual ESC	35	50
HGLRC Forward FD60A 4in1 ESC Electronic Speed	4 in 1 ESC	60	59.99

Table 3.5: ESC Comparison Summary

3.3.4 Camera

The following section will go in depth of the requirements we are looking for in our desired camera along with an in-depth look at each of the cameras we researched to take into consideration. The camera selection will be in a later section of this document.

The camera is an integral component of the detection system since the camera feed is what the software will be detecting the objects from. The requirements of the camera is that it's weight is light enough for the drone to be able to fly with the camera attached with no problems, the quality of the camera is enough where object detection is possible, it is able to transmit a live video feed from the camera itself on the drone down to the phone of the pilot either by itself or with the help of a separate video transmitter, and the camera has to be within the budget of the project. Taking all of these requirements into account, we looked at numerous cameras of types commonly used alongside drones to determine the camera that was most suitable for our needs.

The first type of cameras that we looked into were ones that are more commonly used with drones when used for recording video or taking pictures since we thought those would have the best quality compared to other cameras. Of those, the first camera we researched were the GoPro style cameras which were the GoPro HERO series and the AKASO action camera. The GoPro style of camera consists of a rectangle design with a large lens compared to the body of the camera and are commonly used with extreme sports to capture video footage.

The GoPro HERO comes with a price point of between thirty and forty dollars and is in the lower range of prices for a GoPro HERO series camera. The camera can capture video footage at a resolution of 1920 x 1080 pixels at thirty frames per second or at 1280 x 720 pixels at sixty frames per second.^[42] The GoPro HERO has a weight of just under four ounces and the dimensions were not given for the base model.^[25] The dimensions are around 1.5 x 2.4 x 1.2 inches and the weight for the HERO 1 model is the same as the base HERO model.^[32] After doing some research, the only way to view the footage from the GoPro in real time is through their app and using WiFi. The GoPro HERO also came in a waterproof case from the manufacturer and is unable to be removed which results in extra protrusions from the camera case at the bottom.

The second GoPro style camera we researched was the AKASO EK7000 action camera which, like the GoPro HERO, can capture video footage at a resolution of 1920 x 1080 pixels at sixty frames per second.^[4] We can get this camera for fifty two dollars which is slightly more than the GoPro HERO. The AKASO EK7000 action camera has a weight of twelve ounces and the dimensions of 0.9 x 2 x 1.5 inches which is double the weight of the GoPro HERO but it's also a little bit smaller overall in its dimensions. Unlike the GoPro HERO, the AKASO action camera comes as just the camera and can be inserted into a waterproof case where the camera can be used without any worry of an extra part of the case being in the way or the weight of a case. Just like the GoPro HERO, the AKASO action camera's video feed can only be seen through the manufacturer's phone app using WiFi.

Both GoPro style cameras have resolutions that make the desired quality and both could be attached to a drone, the GoPro HERO needing a little extra to consider with the case that is unable to be removed. Both cameras can also be used on a drone, while the weight is on the high end for cameras, given the drone is designed to carry the weight and the cost of both are also within the desired budget. Where both cameras fall flat is the need to only view the video footage in real time over WiFi where the range is greatly decreased compared to other transmitters and receivers that are commonly used with drones. We had to look at other cameras to accomplish what we were looking for.



Figure 3.32: AKASO EK7000 (left) and GoPro HERO (right) (Permission Requested to Reproduce)

The next camera we decided to look into was the Mobius action camera which we can get from the manufacturers website in a basic package for eighty three dollars.^[27] The Mobius action camera can capture video footage with a resolution of 1920 x 1080 pixels and thirty frames per second or a resolution of 1280 x 720 pixels at sixty frames per second, much like the GoPro HERO camera. The manufacturer also has the dimensions of the Mobius action camera listed as 1.38 x 2.4 x 0.72 inches which is thinner in height than the GoPro style cameras but is also longer in it's length. The manufacturer's website does not have a weight listed but the Amazon listing has the weight as one ounce which is significantly lighter than the GoPro style cameras.^[6] Unlike the GoPro style cameras, the Mobius action camera's manufacturer does not have a phone app that is capable of viewing the live video feed from the camera.

To view the live video feed from the camera, we would need to connect the camera to an independent video transmitter which can then be received on the ground using the pilot's phone. To achieve this, the Mobius action camera's manufacturer makes a separate cable which can be used to connect the camera to a transmitter with or without modification. The cable connects to the USB connector on the camera and separates into a video out cable, an audio out cable, and a voltage input cable.^[49] Each cable can be detached from the main cable if it is unused and the end connectors can then be connected to the transmitter. Depending on the transmitter, the cable can be modified to match the transmitter input if needed. Having to purchase a separate transmitter and connector cables does add a significant amount to the cost of the camera which would push the cost close to being out of the budget if it does not go over.

The Mobius action camera has a video resolution that is the desired quality and the camera itself is able to be mounted to a drone. The camera can be used on a drone since the weight of the camera is only one ounce. The Mobius action camera being able to be transmitted from the drone without WiFi is a big advantage compared to the GoPro style cameras. The price of the Mobius action camera is on the high side of the desired price for the camera but it is still within

the budget. The one concern with the Mobius action camera is the length of the camera being almost two and a half inches and the need for an external transmitter and connector cable which adds a significant cost to the camera. A mount can be designed for the camera but it would require extra time and attention compared to a smaller camera like one commonly used for first person views of drones while in use which we looked into after researching the Mobius action camera.

The third type of camera that we researched was the first person view style of camera that is commonly used when piloting racing drones. The first person view style cameras are commonly more compact and not as large compared to the three other cameras we researched before and they also can have the transmitter built onto the camera itself which can make the implementation of the camera more simple than the other cameras we looked at.

The first camera we looked at that is a first person view style of camera was the RunCam Phoenix 2 that can be purchased from Amazon for thirty seven dollars.^[50] The manufacturer's website lists the weight of the camera as a little under one half of an ounce which is significantly less than the Mobius action camera.^[23] The RunCam Phoenix 2 camera's dimensions are also 0.75 x 0.75 x 0.8 inches which is, again, significantly smaller than any of the other cameras that have been looked at so far. This camera does not have a built in transmitter but it does come with a connection wire that can be connected to a separate transmitter much like the Mobius action camera.

The first person view style cameras do not list resolutions like the other cameras we researched before but, instead, they list the aspect ratio and the horizontal resolution. The RunCam Phoenix 2 has an aspect ratio of 4:3 or 16:9 that can be switched between the two and a horizontal resolution of 1000TVL.^[23] The aspect ratio 16:9 is the same ratio as the resolutions 1280 x 720 pixels and 1920 x 1080 pixels.^[51] The horizontal resolution is not the same as the resolution listed for the other cameras so far, instead it would be equivalent as taking just the horizontal pixel count from the other resolutions. So for 1280 x 720 pixels, the horizontal resolution is 1280TVL and for 1920 x 1080 pixels the horizontal resolution is 1920TVL.^[19]

The second first person view style camera we looked into was the BETA FPV Z02 camera with the built in transmitter. This camera can be purchased on Amazon for thirty one dollars and also includes a mounting bracket for the camera.^[5] The BETA FPV Z02 camera has a weight of just over a tenth of an ounce which is even lighter than the RunCam Phoenix 2 first person view camera we looked at. This camera also has the dimensions of 0.71 x 0.55 x 0.18 inches which is, again, smaller than any of the other cameras we looked at before this one. The BETA FPV Z02 has a camera with a horizontal resolution of 600TVL which isn't as clear of a resolution compared to the RunCam Phoenix 2 camera.

The BETAFPV Z02 is the first camera we looked at that also had its own transmitter built into the camera. The transmitter that is built into this camera is a copper antenna and has a frequency of 5.8 GHz which is pretty standard for video transmitters. This transmitter has six bands with forty eight total channels. More information about transmitters will be found within the transmitter selection section. We did look at a second first person view style camera with a builtin transmitter.

The third first person view style camera with a builtin transmitter we looked at was the Caddx Firefly camera. On Banggood, this camera can be purchased for between twenty seven to thirty three dollars.^[12] The Caddx Firefly camera has an aspect ratio of 16:9 and a horizontal resolution of 1200TVL which is almost the same as a 1280 x 720 pixels resolution and is quite a bit better than either of the other first person view cameras we looked at before this one. The camera also has a weight of just under 0.14 ounces and has the dimensions of 0.55 x 0.55 x 0.63 inches. The Caddx Firefly camera has a transmitter that has very similar specifications as the transmitter that is built into the BETAFPV Z02 camera.

The first person view style cameras are all within the desired budget for the camera on the drone. All three of them are also relatively small compared to the first three cameras we researched. The weights all three are under a half of an ounce which is significantly lighter than the larger cameras we looked into. Where the first person view style cameras fall short is the video resolution. The best of the first person view style cameras is the Caddx Firefly camera which has a resolution a little under what a 1280 x 720 pixels resolution would be.



Figure 3.33: RunCam Phoenix 2 (top left), BETAFPV Z02 (top right), and Caddx Firefly (bottom) (Permission Requested to Reproduce)

Below is a table which summarizes the main specifications of each camera for easy comparisons.

	Cost (\$)	Weight (ounce)	Dimensions (inch)	Resolution (TVL)	Able to Have a Live Feed
GoPro HERO	30 - 40	~4	1.5 x 2.4 x 1.2	1920/1280	Yes (WiFi + Phone App)
AKASO EK7000	52	12	0.9 x 2 x 1.5	1920	Yes (WiFi + Phone App)
Mobius Action Camera	83	1	1.38 x 2.4 x 0.72	1920/1280	Yes (External Transmitter)
RunCam Phoenix 2	37	~0.5	0.75 x 0.75 x 0.8	1000	Yes (External Transmitter)
BETA FPV Z02	41	~0.1	0.71 x 0.55 x 0.18	600	Yes (Builtin Transmitter)
Caddx Firefly	27 - 33	0.14	0.55 x 0.55 x 0.63	1200	Yes (Builtin Transmitter)

Table 3.6: Possible Camera Summary

3.3.5 Battery

3.3.5.1 Cell Chemistries

When choosing a battery for the Object Detection Drone the cell technology was about as close to chosen for us as it could get. From our research, out of all of the battery technologies lithium polymer was almost exclusively used for any RC vehicle. This made choosing the cell to power our drone an easy choice, but more information was needed before blindly following those before us. There are plenty of cell technologies available today from Lithium Ion, Alkaline, NimH, Lead Acid, and the mentioned Lithium Polymer. In regard to our application we had to take a big picture view and determine what would be a make or break attribute of a battery. This exercise made us take into consideration weight before anything else. If the battery chemistry was overly heavy it was likely not worth analyzing any of the other features.

First up for weight analysis is alkaline batteries. A standard alkaline cell is approximately 22 grams making it relatively light compared to our other components. The next closest battery technology to that of alkaline is NimH. It boasts better recharability and comes in at roughly 23 grams per cell which is almost equivalent to that of alkaline, therefore making it another possible choice. First to be disqualified was the lead acid. The analysis regarding lead acid was almost nonexistent as a standard cell is about 680 grams. For instance, a standard 12v lead acid battery used in almost all vehicles has about 19lbs (8.618

kg) of lead alone. Lastly, Lithium Ion and Lithium Polymer were examined. Lithium polymer and Lithium Ion have very similar chemistries. Their biggest difference comes from physical aspects and composition as gone over in our earlier research. Lithium Polymer battery technologies use gel based electrolytes vs liquid based electrolytes. These physical differences lead to different manufacturing processes. In the case of lithium ion cells they are encased in a metal, cylindrical shell. The weight of lithium ion batteries comes primarily from this metal encasing and makes it heavier than its lithium polymer counterparts. A standard 3.7v lithium ion cell weighs in at approximately 45 grams. The lithium polymer cell is often constructed in a pouch form. This gives it the ability to remain lighter as the pouch is generally made of a puncture resistant lightweight plastic. A typical 3.7v pouch cell weighs in at approximately 28 grams. Additionally, this pouch can be molded into almost any shape. Overall, most of the battery technologies could power a drone, but more parameters had to be considered before we made our final decision.

Another major consideration for battery technologies is the Specific Energy or the amount of stored energy per kg. Alkaline batteries come in at 163 Wh/kg making them relatively energy dense. Nimh batteries lag behind that of the alkaline batteries at only 100 Wh/kg. Next was lithium polymer and lithium ion, because of the similarities in their chemistries both have anywhere from 100 to 260 Wh/kg. Even with this large of a range it is not uncommon for these technologies to be on the upper end of the spectrum. Lead acid was previously ruled out on its weight alone and has no further analysis. Through this analysis of the energy density or specific energy we were left with a good idea of which battery technologies might be viable. Alkaline, Lithium Ion and Lithium Polymer are still in contention. While Nimh was ruled out for its low 100 Wh/kg rating.

To finalize our choice on battery technology we finally considered the nominal cell voltage and short circuit current ratings. Alkaline can be ruled out with some simple math. Knowing a typical drone motor requires an input voltage of roughly 12v to 20v, we determined the number of alkaline cells required. With 9 1.5v cells in series the voltage for the motors could be met, but from a weight perspective you would need a minimum of 9 cells x 22 grams (198g). This means about a half pound of alkaline cells would be necessary. This is a bit hefty but not awful considering our drone requires 4 motors. However, from our previous research we know that motors draw a lot of current. Following in the example of a typical drone motor 20 to 30 amps is not an uncommon max current draw. By analyzing the short circuit current rating, a standard alkaline cell can tolerate a burst of around 10 amps. This would not be enough to satisfy the drone power requirements. With only lithium ion and lithium polymer technologies left to evaluate, what makes the lithium polymer so popular in the RC world? Both battery technologies can tolerate roughly 30-50 amps per cell so the deciding factor comes back down to weight. The lithium polymer battery has the overall

advantage as it has almost all of the same parameters as that of a lithium ion, but in a much lighter form factor.

	Nominal Cell Voltage (v)	Specific Energy (Wh/kg)	Cell Weight (grams)	Short Circuit Current Rating (Amperes)	Rechargeable
Alkaline	1.5	163	~22	~10	Dependant on Type
Lead Acid	2.0	30-40	~680	~50-100	Yes
Lithium Ion	3.7	100-265	~45	~30-50	Yes
Lithium Polymer	3.7	100-260	~28	~30-50	Yes
Nickel Metal Hydride	1.2	100	~23	~10	Yes

Table 3.7: Battery Cell Technology Comparison

3.3.5.2 Lithium Polymer Battery Choice

After the analysis of the common available battery technologies, we were able to make a much more confident decision in our choice of lithium polymer batteries. Among the hundreds of listings for lithium polymer batteries many are for all sorts of consumer electronics, other RCs, and specific manufactured drones. Upon further searching it was found that there are numerous companies that sell lithium polymer batteries targeted at the RC and drone market. This narrowed down the options, but there were still many battery parameters to consider. These parameters consist of: cells in series, voltage, capacity, weight and dimensions.

Knowing roughly what we were looking for and looking through some of the top listings we were able to come up with a set of batteries to choose from. As previously mentioned the average drone motor is going to accept somewhere between 12 to 20 volt input and draw 20 to 30 amps. Knowing this we were able to disqualify any 2s options such as the RC LiPo Battery Hard Case by POVWA. A 2s cell configuration only results in a charged voltage of 8.2 and nominal voltage of 7.4. In this case the voltage is under that of the 12v lower bound of a drone motor. The HOOVO Lipo Battery with a 3s cell configuration was close to the cusp, but would still work as its charged voltage would be 12.6 volts. However, when the battery discharges during the flight the voltage will sag and go below the power requirements of a typical drone motor. This would greatly

impact our flight and usability. The other two available options were from the same manufacturer and came in 4s cell configurations. Both of these cells work well in regards to voltage so we furthered our analysis into capacity and discharge rating. Four drone motors at 30 amps a piece is a total of 120 amps. This figure is on the high end and would not be sustained during flight, but could be achieved during small bursts. Regardless, the power source needs to be able to safely deliver this current figure without damaging itself or other components. The C-rating and capacity in batteries is what we need to analyze further in order to determine which can accomplish these sustained high outputs. All batteries can sustain a C-rating or discharge rating of 1C. This means that the capacity, such as in the case of HRB RC LiPo 2200 mAh battery, would be able to sustain a 2200 mA output. Battery technologies have come a long way and many batteries can sustain much higher C-ratings. In our case we have one option of 2200 mA x 30C = 66 A and another at 3300 mA * 60C = 198 A. We picked the HRB RC LiPo 3300mah since it fit the criteria to power all four drone motors. In regards to price, dimensions and weight, all options were similar enough, such that they did not pose much consideration.

	Voltage (v)	Capacity (mAh)	Mass (g)	Series Cells (S)	Discharge Rating (C)	Dimensions (LxWxH)	Price (USD)
HRB RC LiPo	14.8	2200	250	4	30	115mm x 34mm x 34mm	\$27.99
HRB RC LiPo	14.8	3300	330	4	60	135mm x 42mm x 30mm	\$37.99
HOOV O LiPo Battery	11.1	5200	403	3	40	156mm x 44mm x 26.5mm	\$33.99
POVW A RC LiPo Battery	7.4	5200	281	2	50	139mm x 47mm x 27mm	\$32.99

Table 3.8: LiPo Battery Comparison

3.3.6 Video Transmission

3.3.6.1 Transmission Technology

To transmit the data and information between the drone and the pilot, we have to decide on how we want to transmit the signals. Between the transmitter and receiver hardware, there are several different technologies that can be used to transmit wireless signals. The technology options we want to research for use in our project are Wi-Fi, Bluetooth, and radio frequency transmissions. For us to select one of the technologies to use, we decided on a couple of requirements that we want the technology to meet. The requirements are the distance that the signal can travel is at least fifty feet without failure, the signal will experience minimum latency and delay, and the hardware required to use the chosen technology is not difficult to be included on a drone.

One of the technologies that can be used to transmit data signals is Wi-Fi which is something that almost everyone uses on, practically, and daily basis. Wi-Fi is commonly used in houses and shorter ranged data transmission such as the GoPro HERO camera using Wi-Fi to send its video feed from the camera to a phone. Wi-Fi provides a high speed form of data transmission and it is also accurate.^[2] Wi-Fi signals can reach anywhere from nine hundred feet to six thousand feet, which is a shorter distance compared to other technologies, depending on the hardware that is used and the environmental conditions.^[3]

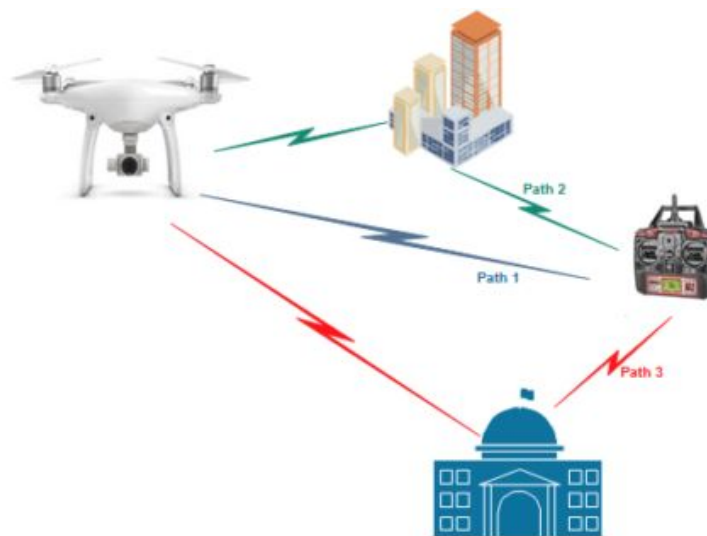

Figure 3.34: Examples of Wi-Fi Signal Pathing (Permission Requested to Reproduce)

There are some disadvantages to using Wi-Fi also. A significant downside to using Wi-Fi for signal transmission is the possibility of receiving interference, especially in a crowded area. Other devices using Wi-Fi can interfere or even replace the signal coming from our drone, commonly large crowds of people will also include a large number of mobile phones which can also be Wi-Fi hotspots and each one of those can be a source of interference. A way to combat this would be changing the frequency of the transmitter and receiver to be a frequency away from what was being interfered with. Wi-Fi can also be highly

affected by the physical environment surrounding the drone and the pilot. The transmitted signals can get reflected off of buildings and other structures which can cause a delay in the signal or even signal drops.

The second of the technologies that we researched was Bluetooth, which is not as commonly used as Wi-Fi but is still commonly used by a larger number of people. Bluetooth is often used in conjunction with mobile phones to connect the phone to external devices such as a speaker to play music or to a smartwatch. Bluetooth has a shorter range than Wi-Fi with a signal distance of around three hundred feet.^[28] That range is without any sort of interference.

Bluetooth has similar disadvantages as Wi-Fi. The signal for Bluetooth can be interfered with from other mobile phones that are using the same frequency. Bluetooth does actively change the frequency that it operates at to try and combat interference problems that can arise and newer Bluetooth versions use a higher frequency range to combat interference from other technologies.^[22] It can use the lower frequencies still to communicate with older hardware that does not support the higher frequencies. Bluetooth's bandwidth is also quite small compared to other technologies, such as Wi-Fi, which decreases the rate that the data can be transmitted.^[21] That can result in a higher latency and delays in the video feed that the pilot is able to visualize.

We decided to research a third type of transmission technology that is commonly used for data transmission, which is radio communication. Radio is one of the most commonly used technologies to use alongside a drone for controlling and video transmission. If the hardware that you use is able, you can achieve a distance of around twenty one thousand feet.^[33] That is a significant increase in distance from both Wi-Fi and Bluetooth.

Just like both of the other transmission technologies we researched, radio communication is affected just the same by interference. If anyone else is using the same frequency as you, the signals can become interfered with or sometimes blocked. That can cause data loss in the transmission or even having the wrong signal being received completely. If there are other individuals piloting their drone or environmental factors blocking the signal, that can cause delay in the video feed or loss of the video feed.

	Range (feet)	Frequency (GHz)
Wi-Fi	~900-6000	2.4 or 5
Bluetooth	~300	2.4 or 6-9
Radio	~21000	2.4 or 5.8

Table 3.9: Possible Transmitter Technologies Summary

3.3.6.2 Video Transmitters

The following section will go in depth of the requirements we are looking for in our desired video transmitter along with an in-depth look at each of the video transmitters we researched to take into consideration. The video transmitter selection will be in a later section of this document.

To transfer the live video feed from the camera to the pilot, we need to attach a video transmitter to the drone. The requirements for the transmitter are that its weight is light enough for the drone to be able to fly when the transmitter is attached with no problems, the range that the transmitter can transmit the video signal is at least fifty feet, the transmitter is able to transmit the video signal in real time with minimal latency so the pilot does not have problems flying the plane, and the video transmitter has to be within the budget of the project. Taking all of these requirements into account, we looked at numerous video transmitters of types commonly used alongside drones to determine the transmitter that was most suitable for our needs. Some of the cameras we researched had builtin transmitters which we looked at more in depth in this section.

There are several different types of video transmitters that can be used but each type has its own common use. The first style of transmitters we researched were larger transmitters that are not targeted to being used on drones. They are commonly larger and come with video connectors instead of bare wire connectors. Transmitters that are not targeted for drone use commonly use a frequency of 5.8 GHz for video transmission. They are also designed to connect to a monitor on the receiver end instead of a phone.

The first transmitter we researched was the GOQOTOMO E-600 video transmitter which also comes with a receiver for twenty dollars on Amazon.^[9] This set of transmitter and receiver is targeted to be used in combination with a backup and rear view parking camera on a car. The transmitter cable comes with a connector for the video signal, a connector for the camera power, and a voltage cable. The GOQOTOMO E-600 video transmitter also includes the antenna which is 5.8 GHz and can transmit over a distance of fifty feet. The transmitter

has a weight of a little more than five and a half ounces and has the dimensions 4.6 x 4.6 x 1.8 inches which is a significant size.



Figure 3.34: GOQOTOMO E-600 Video Transmitter (Permission Requested to Reproduce)

The GOQOTOMO E-600 transmitter has a good weight where it is not terribly heavy and could significantly weigh down the drone. It has the ability to transmit a video signal over a decent range, it is at the minimum distance we are looking to transmit over. The transmitter can also be attached to a camera using its included video connector wire but it might be more intensive to connect it to one of the cameras that do not have the standard video connection. The GOQOTOMO E-600's size is also significantly large where it has a greater likelihood of not being able to fit on a drone that is smaller in size. After this transmitter, we decided to look at ones that are smaller and would be easier to fit on a drone.

The second style of transmitters we decided to look into were smaller ones that are designed to be used on drones, primarily for first person view cameras. These transmitters are significantly smaller in size compared to ones not designed for drone use which also means that these transmitters have a lighter weight than the first type of transmitters we researched. They do use the same frequency to transmit the video signal as the first type of transmitters we looked at. We decided to focus on this type so we researched a greater number than we did the first type of transmitters we looked at.

The first of the transmitters designed for use with first person view cameras we researched was the Eachine TX805 transmitter. This transmitter can be bought for between twenty one and twenty eight dollars on Banggood.^[15] The dimensions of this transmitter targeted for use with a first person view camera is 1.42 x 0.87 x 0.2 inches which is significantly smaller than the first video transmitter we looked into. With the Eachine TX805 transmitter being so much smaller, the transmitter is also lighter with a weight of just under three tenths of an ounce. Using a frequency of 5.8 GHz, this transmitter can transmit a video signal over at least

three thousand feet.^[31] That is a significant increase in range compared to the GOQOTOMO E-600 transmitter.

A second transmitter that is designed to be used with a first person view camera that we looked at was the TBS Unify Pro32 video transmitter. For a higher price of fifty dollars, this transmitter can be bought on GetFPV and is one of the highest priced transmitters we researched.^[57] We also looked at a less expensive version of the same transmitter which will be discussed after this one. The TBS Unify Pro32 has a weight of a little over three tenths of an ounce which is just a tad over the weight of the Eachine TX805 transmitter. The dimensions are also just a tiny bit greater than the Eachine TX805 transmitter as 1.46 x 0.98 x 0.23 inches but is still relatively small and within the desired dimensions. With a frequency of 5.8 GHz, the TBS Unify Pro32 can transmit a video signal over at least nineteen thousand feet, which is a significant increase from the Eachine TX805 and the GOQOTOMO E-600 transmitters we looked at before this one.^[58]

The third first person view camera designed transmitter we researched was the less expensive version of the TBS Unify Pro32, the TBS Unify Pro 5G8 HV. You can purchase this transmitter for thirty dollars on GetFPV which is almost half the price of the Pro32 version.^[59] The Pro 5G8 HV version is over half of the weight at 0.15 ounces and has the dimensions of 1.06 x 0.79 x 0.16 inches which is smaller than the Pro32 version of the transmitter by a small amount. The frequency that this transmitter uses is the same as the others at 5.8 GHz according to the frequency table in the transmitter manual and can transmit the video signal up to around six thousand and five hundred feet. Some of the cameras we researched had builtin transmitters.

All of the transmitters that are designed to be used with a first person view camera are compact and are able to transmit over a considerable distance. The TBS Unify Pro32 was a little more expensive but the TBS Unify Pro 5G8 HV was within the budget along with matching the requirements like the more expensive version. All three of the transmitters are able to be wired up to an antenna if they do not come with one and they are also able to be connected to a camera without any issue. We also wanted to look more in depth into those transmitters to determine if they would be an option or not.



**Figure 3.36: TBS Unify Pro32, TBS Unify Pro 5G8, and Eachine TX805 (left to right)
(Permission Requested to Reproduce)**

Two of the cameras we researched have video transmitters built in with the camera. Visually, the built in transmitters look very similar to the other transmitters made to be used with a first person view style camera. The main difference is that the camera and antenna are both attached before shipment and take a little more effort to modify than having the ability to modify the connections and wires before connecting the components.

The first camera we looked into that included a built in transmitter was the BETA FPV Z02 camera with a total price of thirty one dollars.^[5] The transmitter included with the camera has a frequency of 5.8 GHz and a range of at least three thousand feet. The weight of the transmitter is included in the weight of just over a tenth of an ounce that was stated in the description of the camera. The dimensions of the transmitter are different from the camera with the only dimension given by the manufacturer is the length of the transmitter which is 0.91 inches. The transmitter that is built in with the BETA FPV Z02 camera is a little bit shorter than any other transmitter we have looked at up to this point.

The second camera that we researched with a built in transmitter was the Caddx Firefly with a purchase price of between twenty seven to thirty three dollars.^[12] The transmitter that is built into this camera uses a frequency of 5.8 GHz and has a range of at least three thousand feet. The dimensions listed in the manual for the transmitter are 0.59 x 0.55 inches which is the smallest transmitter out of all of the other ones that we researched.^[61] The weight of the transmitter that is built into the Caddx Firefly is included in the just under 0.14 ounces that was stated in the weight for the camera.

The two transmitters built into cameras that we looked into check all of the boxes that we desire for a transmitter. They are compact and do not take up much room and they are able to transmit video over a good distance. We would not have to worry about connecting the transmitter to the camera with either of these two since they do come built into the camera but if we need to modify them in any way it would be more effort compared to having the ability to modify them from the start. The distance that they can transmit is pretty standard for the power configuration that they both output but it is a shorter distance than some of the transmitters we researched that were not built onto a camera.

Below is a table which summarizes the main specifications of each transmitter for easy comparisons.

	Cost (\$)	Weight (ounce)	Dimensions (inch)	Range (feet)	Frequency (GHz)
GOQOTOMO E-600	25	~5.5	4.6 x 4.6 x 1.8	50	5.8
Eachine TX805	21 - 28	~0.3	1.42 x 0.87 x 0.2	>3000	5.8
TBS Unify Pro32	50	~0.3	1.46 x 0.98 x 0.23	>1900 0	5.8
TBS Unify Pro 5G8 HV	30	0.15	1.06 x 0.79 x 0.16	~6500	5.8
BETA FPV Z02 Transmitter	31	~0.1	0.91	>3000	5.8
Caddx Firefly Transmitter	27 - 33	~0.14	0.59 x 0.55	>3000	5.8

Table 3.10: Possible Video Transmitter Comparison Summary

3.3.6.3 Video Receivers

The following section will go in depth of the requirements we are looking for in our desired video receiver along with an in-depth look at each of the video receivers we researched to take into consideration. The video receiver selection will be in a later section of this document.

To match the video transmitter, we have to have a video receiver that will receive the signal from the drone. The requirements for the video receiver are that the receiver is able to receive the video signal in real time with minimal latency so the pilot does not have problems flying the plane, the receiver is capable of receiving a frequency that matches with the frequency range of the selected video transmitter, and the video receiver has to be within the budget of the project. Taking all of these requirements into account, we looked at numerous video receivers of types commonly used alongside drones to determine the receiver that was most suitable for our needs.

The first video receiver that we researched was the Eachine ROTG01 which can be purchased on Banggood for thirteen dollars.^[13] The frequency range that this receiver can cover is 5.6 GHz - 5.9 GHz which contains the frequency of all of the video transmitters that we researched. The Eachine ROTG01 also provides one hundred and fifty channels which can be utilized to search various frequencies for an active signal within the frequency range. To connect the

Eachine ROTG01 video receiver to a phone, the receiver has a USB connection included that can be used with a USB to mini USB or USB to USB C cable to connect it to the phone. There is only one antenna connection available on the receiver and that results in the receiver being more easily affected by interference and having a shorter distance than one that has more than one antenna connection available for use.

The second receiver that we looked into was the Eachine ROTG02 which is a more advanced version of the previous receiver. On Banggood, you can purchase this video receiver for twenty four dollars which is almost double the price of the lower model of receiver.^[14] The frequency range that the Eachine ROTG02 can cover is the same range as the ROTG01 which is 5.6 GHz - 5.9 GHz. The Eachine ROTG02 also includes the same amount of channels as the ROTG01, one hundred and fifty, for scanning the frequency range for an active signal from the video transmitter. The Eachine ROTG02 also connects to the phone of the pilot with the same method as the ROTG01 that we looked at before this receiver. The main difference between the two video receivers is that the Eachine ROTG02 has two antenna connections instead of just a single one. Having two antenna connections allows for more stability with the signals that the receiver is receiving and allows the Eachine ROTG02 to be less vulnerable to signal interference unlike the ROTG01.

The third video receiver that we researched was the Skydroid OTG receiver which can be purchased for twenty eight dollars on GetFPV.^[34] Even with a different manufacturer than the other two video receivers that we have researched so far, the Skydroid OTG receiver has almost identical specifications as the Eachine ROTG02. The Skydroid OTG can receive frequencies in the range of 5.6 GHz - 5.9 GHz much like the other two receivers. Also like the other two video receivers we researched before this one, the Skydroid OTG provides one hundred and fifty channels that can be utilized to search the frequency range for an active signal that can be received. This video receiver also connects to the phone of the pilot through a USB connection on the receiver. That connection can connect to the phone's USB port whether it is a mini USB or a USB C port through a cable that converts from USB to the desired port. Lastly, the Skydroid OTG provides two antenna connections which provides an improved signal stability for a greater quality of signal.

The last video receiver could be bought for a price on Banggood of thirty dollars and it was the RC832HD receiver.^[17] The RC832HD video receiver is able to receive the frequency of 5.8 GHz which does match all of the video transmitters that we researched. That is not as broad of a range as the other three video receivers we have looked at up to this point, however. As a large decrease compared to the other three receivers we researched before the RC832HD, this receiver only provides forty eight channels compared to the other three receivers one hundred and fifty. Another difference that the RC832HD has compared to the

other three video receivers is that it does not have a USB connection that can be used to connect to the phone of the pilot. Instead, this receiver has a HDMI connect that can be utilized if we have a cable that can convert from HDMI to mini USB or USB C. The RC832HD provides one antenna connection which can cause the signal connection to the receiver to be more susceptible to interference compared to the two video receivers we researched that provided two antenna connections.



Figure 3.37: Eachine ROTG01, Eachine ROTG02, Skydroid OTG, RC832HD (left to right) (Permission Requested to Reproduce)

	Cost (\$)	Number of Channels	Frequency Range (GHz)	Number of Antenna Connections	Output Connection Type
Eachine ROTG01	13	150	5.6-5.9	1	USB
Eachine ROTG02	24	150	5.6-5.9	2	USB
Skydroid OTG	28	150	5.6-5.9	2	USB
RC832HD	30	48	5.8	1	HDMI

Table 3.11: Possible Video Receiver Main Specifications Summary

3.3.7 Drone Controller

The following section will go in depth of the requirements we are looking for in our desired drone controller along with an in-depth look at each of the drone

controllers we researched to take into consideration. The drone controller selection will be in a later section of this document.

To pilot the drone, we need to have a controller that the pilot can use from the ground. The requirements for the controller that we desire are the ability to control the drone from a distance of at least fifty feet, for there to be minimum latency from the controller to the drone for accurate flight control, and the controller has to be within the budget of the project. Taking all of these requirements into account, we looked at numerous controllers of different types that are commonly used for drones to determine the controller that is most suitable for our needs. All controllers used for drones use radio transmitters and receivers to communicate and control the drone.

The first style of controller we researched was the traditional style of radio controller that people might think of when they think of a controller for a drone. The controllers are commonly larger and resemble a square or rectangle for their shape. Some have a LCD screen built into the controller that can display information about the drone and/or the controller.

The first controller that we researched was the Taranis Q X7 can be purchased on Amazon for one hundred and thirty nine dollars.^[8] In our research, we could not find an official range stated but the user DronesGator on YouTube tested the range of the Taranis Q X7 and found it to be around four thousand and nine hundred feet.^[20] This radio controller has a weight of 33.6 ounces and has the dimensions of 8 x 8 x 4 inches. The Taranis Q X7 uses a frequency of 2.4 GHz which is commonly used for radio controllers. The controller also provides sixteen channels that can be used to send commands or inputs to the drone.

The second radio controller we looked into was the Flysky FS-i6X which is more than half the price of the Taranis Q X7 at fifty seven dollars on Amazon.^[7] Like the Taranis Q X7, we could not find an official distance that the controller can go until the signal becomes unusable. The user Matt Gholson on YouTube performed a test with the controller and found that it could go about three thousand and seven hundred feet.^[29] This radio controller weighs almost ten ounces lighter than the Taranis Q X7 at a weight of just under twenty five ounces. The Flysky FS-i6X is a tiny bit larger than the Taranis Q X7 with the dimensions 9.45 x 8.27 x 4.33 inches. The Flysky FS-i6X and the Taranis Q X7 do use the same frequency of 2.4 GHz and the Flysky FS-i6X has six to ten channels that can be used compared to the sixteen channels of the Taranis Q X7.

A third radio controller we researched was the Turnigy 9X which can be found on HobbyKing for seventy four dollars.^[62] This controller has nine channels and uses a frequency of 2.4 GHz which is about the same number of channels as the Flysky FS-i6X but less than the Taranis Q X7. A little under the weight of the Flysky FS-i6X, the Turnigy 9X weighs just above twenty four ounces and its

dimensions are 7.48 x 4.41 x 10.12 inches. During our research, we could not find an official range for the controller but FPV Frenzy has an article on their website that states the max range for the Turnigy 9X is about one thousand, six hundred, and forty feet.^[30]

All of the traditional style of radio controller makes every mark that we are looking for in our desired controller. All three of the controllers are able to transmit the inputs over at least one thousand feet. The Taranis Q X7 is quite far out of our budget and the Turnigy 9X is at just out of our price range but the Flysky FS-i6X is within our price range. The main requirement that the traditional style radio controllers fail is the price with the cheaper ones still being towards the higher edge of our budget. The next style of controller we researched were ones that resembled video game controllers.

The radio controllers that resemble video game controllers are smaller and more compact compared to the three controllers we looked into before this. Other than the design and layout of the controller, there is no hardware difference between the video game controller style and the traditional style of radio controllers.

The first video game controller style of radio controller that we researched was the Taranis X-Lite. On Banggood, we can purchase this controller for one hundred and forty either dollars.^[16] According to the test performed by DronesGator on YouTube, the range of the Taranis X-Lite is a few feet better than the Taranis Q X7 with a range of around four thousand and nine hundred feet and they use the same frequency of 2.4 GHz.^[20] The Taranis X-Lite is significantly lighter compared to the other three controllers we looked at before with a weight of just under eleven ounces. The manufacturer does not have the dimensions listed but by reviewing a listing on Banggood for the Realacc X-Lite Drone Shoulder Bag, we can estimate the size of the controller to be 8.66 x 6.3 x 3.94 inches.^[18] The Taranis X-Lite has the same amount of channels that it can use as the Taranis Q X7 controller with sixteen channels.

The second video game controller style of radio controller we looked into was the Turnigy Evolution that can be purchased on Amazon for ninety dollars.^[11] With a weight of just over twelve ounces, this controller is just slightly heavier than the Taranis X-Lite. The Turnigy Evolution also has the dimensions of 7.48 x 6.69 x 3.35 which is about the same as the other video game controller style of radio controller. The Turnigy Evolution has half the amount of channels as the Taranis X-Lite with eight channels that it can use. According to Sleepwalker FPV on YouTube's range test, the Turnigy Evolution has a range of about six thousand and five hundred feet.^[35]

The video game controller style of radio controllers have similar specifications as the traditional style of controller. The main difference is the video game controller styles are smaller and more compacted. The Taranis X-Lite is over our desired

budget for the controller by a significant amount and the Turnigy Evolution is also over by just a little bit. Other than the price, both controllers meet our requirements for a controller. One last option that we researched was using our phone either through an app or programming the controller into the same program as our object detection.

After reviewing several phone apps that claim they can be used to control a drone, the majority of the reviews state that the apps do not work. Even if the apps did work, the app uses WiFi to connect from the phone to the drone which does not have a range as long as we desire. Programming a controller ourselves would yield the same distance result since WiFi is the most common method to connect from a phone to a drone, except if we use an external transmitter and receiver much like acquiring the camera feed on the phone of the pilot of the drone. We determined that the phone was not going to be a viable option for our drone controller.

Below is a table comparison of the transmitters taken into consideration. The comparisons include cost, weight, dimensions, number of channels, range, and frequency.

	Cost (\$)	Weight (ounce)	Dimensions (inch)	Number of Channels	Range (feet)	Frequency (GHz)
Taranis Q X7	139	33.6	8 x 8 x 4	16	~4900	2.4
Flysky FS-i6X	57	~25	9.45 x 8.27 x 4.33	6 - 10	~3700	2.4
Turnigy 9X	74	~24	7.48 x 4.41 x 10.12	9	~1640	2.4
Taranis X-Lite	148	~11	~8.66 x 6.3 x 3.94	16	~4900	2.4
Turnigy Evolution	90	~12	7.48 x 6.69 x 3.35	8	~6500	2.4

Table 3.12: Possible Drone Controller Specifications Summary

3.3.8 Flight Controller

First flight controller that was attention grabbing was the Navio2. This is due to its impeccable features and specifications. The Navio2 is a HAT (Hardware attached on top) created to be attached to a Raspberry Pi. It is most popularly used with the Raspberry Pi 3. This flight controller setup offers a 1.2GHz, 64-bit quad-core ARMv8 CPU and 1GB RAM. The processing power provided would be unparalleled for a drone build. It offers a variety of high quality sensors that

include: MPU9250 9DOF IMU, LSM9DS1 9DOF IMU, MS5611 Barometer, GPS, and an RC I/O co-processor. The two IMU's improve the flight experience and redundancy. This is highly efficient and will lower delay time for the drone to execute control demands. The MS5611 Barometer offers altitude measurement accuracy of up to 10cm. Moreover, the triple redundant power supply on this setup provides overvoltage protection and a power module port for voltage and current sensing. This setup allows for a wide range of possible applications the drone can be used for given its computational power. However, the price of the Navio2 HAT itself is at \$168 on the official website. Additionally, a Raspberry Pi 3 computer is priced approximately at \$35. For our purposes this flight controller exceeds our needs and our cost requirements.

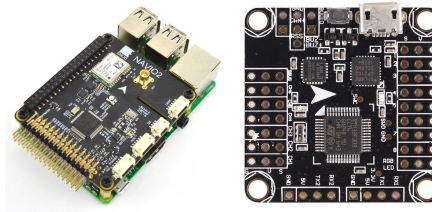

Figure 3.38: Navio2 HAT Attached to Raspberry Pi 3 (left) and X-Racer F303 Flight Controller (right)

The next flight controller researched was the X-Racer F303 v2.0 flight controller. This flight controller although not as robust as the Navio2, the processing power is just fine for our purposes. It carries an STM32 F3 MCU that runs at a clock rate of 72MHz. This setup offers 256KB flash memory and 48KB RAM. The features and sensors integrated on the flight controller are as follows: Battery Voltage monitoring (as opposed to its v1.0 predecessor), RSSI support to detect RF signal strength, RGB LED support, and MPU6050 Accelerometer and Gyroscope. However, it does not offer a barometer or a magnetometer. It does not offer a way to add these sensors to the board either. Since our purpose is not racing or recreational FPV flight, this is a big downside to this board.

The Naze32 is a small (36x36mm) flight controller based on a 32-bit STM32 processor running at 72MHz. Compared to other popular FC such as the KK2, APM2, and Crius AIO, which are all based on 8-bit platforms running at 16Mhz, the Naze32 provided the computational power we need. It comes in various versions, the one we will be using is the Naze32 Full version. It comes with a MS5611 barometer and a HMC5983 magnetometer.

Other versions of the Naze32 flight controller include the Naze32 6 DOF, Naze32 Acro, and Naze32 10 DOF. The Naze32 6 DOF is the most basic version of the Naze32 boards and the cheapest. The '6 DOF' implies it has six degrees of freedom. Which means it has a 3-axis accelerometer and a 3-axis gyroscope. This is most suitable for experienced drone pilots as there is no function to hold the drone at specific altitudes.

Component	6DOF	Acro	10DOF	Full
Barometer	None	BMP280	BMP280	MS5611
IMU	MPU6500	MPU6500	MPU6500	MPU6500
Magnetometer	None	None	HMC5883	HMC5983

Table 3.13: Different Versions of the Naze32 FC

There is not much of a difference in the price of most Naze32 versions. The Naze32 Full version comes with a better quality barometer and magnetometer than other less elaborate versions of it. Therefore, additional external components equivalent to the barometer and magnetometer can be compensated while also allowing for more open-ended design.

The Naze32 Full version is better than other flight controllers in a way that it has better flight stability and reliability of the chipset. There are multiple options for different configuration in terms of peripheral connections and features. Moreover, better performance can be achieved by adding features in this flight controller board. It has sufficient processing power and has a fine precision which adds to the performance and stability of the flight.

The other advantage of this Flight controller is that it has higher idle time i.e. 75% idle time the whole flight which is better for battery timing and performance during the flight.

The Naze32 is more compatible due to its small size and higher functionality. It has excellent performance and less weight which makes it perfect for drones. A visual representation of Naze32 full version is shown below:

4.0 Related Standards & Design Constraints

The following standards, regulations and constraints are to be adhered to in the design and operation of the drone as well as the software application.

4.1 Related Standards

Standards are one of the most important aspects of designing and engineering. Without standards safety would be compromised, devices would have a much harder time communicating and many other ill effects would arise. For our Object Detection Drone we have a mixture of software and hardware standards that will influence our design decisions in direct and indirect ways. These standards are developed and touched by numerous different governing bodies. What will follow is an overview of some key bodies that will have guided us and influenced us in the development of our Object Detection Drone.

ANSI a not for profit organization oversees and accredits the development of standards. Without ANSI and other governing bodies there would be no standardized process for the development of standards. For finding standards the National Institute of Standards and Technology (NIST) whose mission is to “promote U.S. innovation and industrial competitiveness by advancing measurement science, standards, and technology in ways that enhance economic security and improve our quality of life” provides many great searching tools.

In order for the level of interoperability the world currently enjoys whether it be cellular communications and charging ports or paper sizing, international standards are necessary as well as bodies that govern them. Standards for electronics and technology can be found through the International Electrotechnical Commission (IEC) as well as the International Organizations for Standardization (ISO). Additionally these two bodies also work closely together on standards as the ISO/IEC. The IEC takes an approach of achieving worldwide conformity to “...ensure the safety, efficiency and interoperability of electrical, electronic and information technologies, to enhance international trade, facilitate broad electricity access and enable a more sustainable world.” With this mouthful of a mission statement we can understand further that these organizations strive to meet larger goals than that of just standards. These organizations use standards as a means to have far reaching, positive influence on the products of the world.

As it can be seen, there are numerous bodies that write and oversee development of standards, but there are many more not mentioned for all sorts of industries. The remainder of this section will address some specific standards that have influenced the design of our Object Detection Drone.

4.1.1 Battery Standards

Following are the Battery Standards used for the Lithium Polymer batteries which are also a global practice for using Lipo batteries in Drones.

e-Stewards

The “e-Stewards Standard for Ethical and Responsible Reuse, Recycling, and Disposition of Electronic Equipment and Information Technology” is a standard that incorporates the well known ISO14001 standard. It focuses on certifying electronic recyclers and companies in the process of managing electronic wastes. The e-Stewards standard focuses on what a responsible recycler should be doing while the incorporation of the ISO14001 standard takes into consideration the processes of how the recycler should design their environmental management systems. The e-Stewards standard features focus on: protection of data, prevention of pollution, reduction of environmental impacts, etc. In regard to lithium batteries the e-Stewards standard provides procedures and tools for determining their reusability.

IEC62133

IEC62133 is an International Safety Standard for Lipo Batteries. Its second edition was published in 2012 and it is practiced globally for the safety of Lipo batteries for usage as well as Transportation.

This safety standard is used for single cell batteries as well as battery packs which contain alkaline batteries and non acid electrolytes batteries. Lipo Batteries also comes in the range of these standards.

The testing for these batteries are followed by a series of standard procedures. For Lipo batteries, these batteries should be charged at room temperature (20-25 °C). In the next step these batteries are charged at two extremes of temperatures which are 10C and 40C and observe the change in charging and battery health.

Another test for Lipo batteries includes a constant voltage test which again follows two procedures. One at the recommended by the manufacturer and other by applying the condition at both extremes for observing the changes in battery. For this purpose, a battery is charged for 7 days at constant voltage as recommended by the manufacturer and then in another experiment, the extreme voltages are applied.

These Standards also include the crushing of the batteries and observing its effects on the environment, which includes the release of harmful materials such as lead.

The experiment for short circuiting of batteries is also performed and the safety precautions are proposed accordingly. Moreover, Nickel cadmium batteries and Nickel hydrogen batteries also follow these standards.

UN38.3

UN38.3 sub-section from a standard known as “Recommendations on the Transport of Dangerous Goods, Manual of Tests and Criteria.” It proposes safety tests for the transportation of lithium metal and lithium ion batteries. The procedure indicates eight individual tests for the qualification of a battery to be transported.

These test procedures include:

- 1) Altitude Simulation
 - a) This test is meant to simulate air transport under low-pressure conditions. Test cells and batteries shall be stored at a pressure of 11.6 kPa or less for six hours at ambient temperature 15 to 25 degrees celsius. To pass the units under test (UUT) should not leak, vent, disassemble, or rupture.
- 2) Thermal Rest
 - a) This test is meant to assess battery seal integrity and internal electrical connections. The test stores cells and batteries of r six hours at a test temperature of 70 to 72 degrees celsius. This heat cycling is repeated 10 times with less than 30 minutes between cycles. The UUTs are then stored for 24 hours. To pass UUTs should not leak, vent, disassemble, or catch fire.
- 3) Vibration
 - a) This test is meant to simulate vibrations during transit. Test cells and batteries are affixed to a vibrating machine. The vibration is a sinusoidal waveform with a logarithmic sweep between 7 Hz and 200 Hz over 15 minutes. This test is repeated 12 times over the course of 3 hours. To pass the UUTs should not leak, vent, disassemble, or catch fire.
- 4) Shock
 - a) This test is to assess the robustness of cells and batteries against cumulative shocks. Test cells or batteries are subjected to a half-sine shock of peak acceleration depending on the mass of the battery. The pulse duration shall be 6 milliseconds for smaller batteries and 11 milliseconds for larger batteries. The test is repeated 3 times in 6 directions for a total of 18 shocks. To pass the UUTs should not leak, vent, disassemble, rupture, or catch fire.
- 5) External Short Circuit
 - a) This test simulates an external short circuit. Test cells or batteries shall be heater for a period of time necessary for the external case

to reach a stabilized temperature between 53 and 61 degrees celsius. The UUTs will then experience a short circuit condition of a total external resistance less than 0.1 ohm. This short circuit condition will last for at least one hour after the encasement has returned to 53 to 61 degrees celsius. The short circuit and cooling phase shall be conducted in at least ambient temperatures. To pass the UUTs should not exceed 170 degrees celsius and there is no disassembly, rupture, or fire.

6) Impact/Crush

- a) This test simulates mechanical abuse from an impact or crush that may result in an internal short circuit. Test cells or batteries shall be placed onto a flat smooth surface. A 316 stainless steel bar is to be placed across the center of the sample. A 9.1 kg mass is to be dropped from a height of 61 cm at the intersection of the bar. After a single impact the UUT will then experience a crush force of 13 kN applied by a hydraulic ram. To pass the UUTs should not reach an external temperature of 170 degrees celsius, there is no disassembly, or fire.

7) Overcharge

- a) This test evaluates the ability of a rechargeable cell or battery to withstand an overcharge condition. Test cells or batteries shall endure a charge current twice the manufacturer's recommended maximum continuous charge current. The minimum voltage shall be the lesser of 22 V or two times the manufacturer's recommendation if under 18 V. Otherwise, the voltage shall be 1.2 the max charge voltage. The duration of the test is for 24 hours. To pass the UUTs should not disassemble or catch fire.

8) Forced Discharge

- a) The test evaluates the ability of a rechargeable cell or battery to withstand a forced discharge condition. Test cells or batteries shall be forced to discharge at a rate greater than or equal to the maximum discharge current specified by the manufacturer. This is accomplished by connecting the UUT in series with a DC power supply attached to a resistive load at the maximum discharge current. This test continues for hours equal to the rated capacity divided by the test current. To pass the UUTs should not disassemble or catch fire.

4.1.2 Design Impact of Battery Standards

The design impact of e-Stewards, IEC62133, and UN38.3 are far reaching in our project. The lithium polymer battery pack is the power source for the entire system. Without it our Object Detection Drone would be non functional. With

such a large role it is necessary for us to make sure we take the information provided within these standards and apply it to our operations and design.

Lithium polymer batteries do not last forever and will eventually need to be disposed of in a proper way to avoid harmful environmental and health effects. IEC62133 makes note of the harmful impact lithium ion batteries can have during its crush testing. The e-Stewards standard provides a lot more information on the procedures and management surrounding recycling rechargeable batteries, such as our lithium polymer battery. Although we can not adhere to establishing environmental management systems on an organizational level as defined within the standard, we can still allow this information to influence our decisions on handling all of our electronic waste during the design of our Object Detection Drone.

The IEC62133 and UN38.3 standards provide a plethora of information regarding the testing of lithium batteries before transportation. During our testing of our design the batteries will be transported to and from testing destinations. The standards provide us with insight on what scenarios to avoid when handling our Object Detection Drone. For instance, avoiding leaving our lithium batteries in hot vehicles or in direct sunlight where they have the potential to overheat or degrade. Although we will not be repeating the tests proposed, we can still draw parallels from these standards that will allow us to improve the safety of our design. In the case of the battery falling out of the drone, such as in the impact tests, we can design a secondary safety harness. Another choice we can make is to further insulate the batteries contacts in case of the drone crashing. This will help prevent the external short circuit conditions mentioned in UN38.3 that could potentially result in a fire.

4.1.3 Drone Standards

The following are standards pertaining to the growing Unmanned Aircraft, Unmanned Aircraft Systems, and Drone markets.

ISO 21384-3:2019

ISO 21384-3 is “Part 3: Operation procedures” of the parent standard ISO 21384 “Unmanned aircraft systems.” This standard is developed to provide a minimum safety and quality to the unmanned aircraft systems (UAS) field. This standard also aims to provide coordination and organization in the airspace. It is similar in scope to regulatory bodies like the Federal Flight Administration (FAA), but on a smaller level. This standard’s main focusing points are on the safe operation of a drone or UAS.

Information is provided on the terminology associated with UAS, such as what is defined as an “unmanned aircraft accident”, what does “remote pilot in

command” (RPIC) mean. After clearing any obscurity within the terminology the standard proposes that all operators have the appropriate documentation in regards to permission to fly, relevant certifications, and any other related documentation. From an accountability perspective the standard goes over insurance for the UAS operators as well.

For safe flight operations of UAS ISO 21384-3 adheres to a very similar structure to that of an actual manned aircraft. Including sections for Flight Preparation, In Flight Operations, and Maintenance. Flight preparation is broken down into two operations: a preflight inspection and communications planning. A preflight inspection checks the UAS for any damage that would make it unworthy to fly or a possible safety concern. The establishment of communications allows for UAS operators to have direct communication with other UAS operators or in some circumstances an air traffic control tower. In flight operations go over many topics, including Operational Limitations, Autonomous Operation, Handovers, Operations at Night, Abnormal and Contingency Procedures, etc. All of these topics sum up to making sure the drone or UAS is operated by qualified personnel and operated in a way that provides the most safety to the property and persons of those around it. The last main topic is covered is maintenance. Maintenance for a UAS comes in the form of updating software and hardware as things break or improvements are released for safe flight operations. Additionally, the maintenance section goes over the configuration of the UAS as many run custom configurations.

4.1.4 Design Impact of Drone Standards

The ISO 21384-3 standard provides us insight into the safety of operating and designing the Object Detection Drone. To ensure we can adhere to this standard we have agreed on incorporating many of topics into our own testing and design processes. Adoption of preflight inspections, night operation guides, pilot documentations, and maintenance guidelines have been in discussion amongst the group when the Object Detection Drone is to be test flown.

Preflight inspections of the UAS will allow us to find potential failures or safety concerns before each test flight. This should also result in more stringent test procedures, as the inspection can provide a means for examining any changes between tests.

Due to the nature of our drone requiring light to take imagery and regulations, it is unlikely that it will be flown during night. However in the case of low light situations, such as overcast or dusk, we have considered design improvements. Taking into account that in these situations flight via the onboard camera alone may not be sufficient, we have decided on the addition of LEDs for constant visual aid on the location of the drone. These LEDs can also improve the safety of the drone in other ways. Indication for low battery, angle, and other diagnostic

concerns can emit a given status color. This will allow the operator to bring the drone down from the air prior to any failure or uncontrolled landings.

In regards to the adoption of the regular maintenance and documentation, we will adhere to both during the course of our development. By making sure all of the software and hardware are functioning as intended we can limit the chances of any accidents or destruction of hardware. Additionally, by always having appropriate documentation when test flights are necessary we will have no hiccups with local regulations and be able to operate in a safe manner.

4.1.5 Additive Manufacturing Standards

The following are standards pertaining to additive manufacturing. Additive manufacturing is a term mostly reserved for large scale manufacturing. However 3D printing with plastic filaments can be considered a type of additive manufacturing. Frame and mount components of our Object Detection Drone are constructed with 3D printing methods.

ISO/ASTM 52910:2018

ISO/ASTM 52910 is the standard for “Additive manufacturing -- Design -- Requirements, guidelines and recommendations.” This standard is meant to provide guidance “...during the design of all types of products, devices, systems, components or parts that are fabricated by any type of AM system.” The standard is broken down into two major components Design Opportunities and Limitations as well as Design Considerations. In the Design Considerations section discussion for consideration in usage, sustainability, business, geometry, material property, etc. can be found. Exposures to the radiation, chemical, and thermal environments as well material properties are focused on throughout most of the standard.

4.1.6 Additive Manufacturing Standards

Although not all of the information within ISO/ASTM 52910 is relevant to one off productions and filament based 3D printing, it was still able to spark new considerations for our Object Detection Drone design. Knowing the amount of thrust that will be generated by each individual motor we needed to make sure the mechanical properties of our filament can sustain the force exerted. Additionally the thermal properties of our filament must be able to sustain the combination of direct sunlight and the heat without breaking down or becoming brittle.

4.1.7 Radio Frequency Standards

For wireless communication, radio frequencies are separated into ranges that are sectioned off even more into channels. Each channel is separated by 5 MHz and

the number of the channel is determined by the frequency that is at the center of the channel. The IEEE 802.11 standard provides these ranges and multiple sections of this standard are ones that apply to the frequencies we are going to be using in our project.

IEEE 802.11a

Section a of the 802.11 IEEE standard operates in the 5 GHz radio frequency range and is an orthogonal frequency-division multiplexing based air interface. The throughput that is achieved by this section of the standard is in the mid 20 Mbit/s with a maximum data rate of 54 Mbit/s. It uses the 5 GHz frequency range due to the crowding of the 2.4 GHz frequency range but is more susceptible to the transmission being absorbed by objects since it can not penetrate them as easily. It also has a longer distance range as the 2.4 GHz frequency range and a lower chance of experiencing interference since the 5 GHz frequency range is less crowded.^[40]

IEEE 802.11b

Section b of the 802.11 IEEE standard operates in the 2.4 GHz radio frequency range and has a maximum data rate of 11 Mbit/s. Devices using this standard have a wide array of other devices that can cause interference with it since the 2.4 GHz frequency range is vastly crowded with devices utilizing it. Anything that is an unlicensed international radiator has to not interfere with users of the 2.4 GHz frequency range that have an allocation and must also have the ability to tolerate interference from those same users.^[40]

IEEE 802.11g

Section g of the 802.11 IEEE standard operates in the 2.4 GHz radio frequency range but utilizes the same orthogonal frequency-division multiplexing as section a. This section of the standard is capable of a maximum data rate of 54 Mbit/s with a throughput of around 22 Mbit/s. This section is affected by interference from other devices using the same 2.4 GHz frequency range much like section b of the 802.11 standard.^[40]

IEEE 802.11n

Section n of the 802.11 IEEE standard was the first draft of certification which added multiple-input multiple-output antenna support. It utilizes both the 2.4 GHz frequency range and the 5 GHz frequency range. The range for its data rate is from 54 Mbit/s to 600 Mbit/s.^[40]

IEEE 802.11ac

Section ac of the 802.11 IEEE standard expands on section n which expanded the channels of the 5 GHz frequency range from 40 MHz to 80 MHz or 160 MHz.

This section also added multi-user multiple-input multiple-output and a higher-order modulation of 256 quadrature amplitude modulation from 64 quadrature amplitude modulation.^[40] It has a throughput of at least 500 Mbits/s with a single-link or a throughput of at least 1 Gbit/s with a multi-station link.^[41]

IEEE 802.11ax

Section ax of the 802.11 IEEE standard is the successor of the ac section of the standard. This section is not officially adopted yet by the 802.11 standard but is expected to in September of 2020. It is set to increase the throughput of section ac by four times the amount and also decrease the amount of interference that can be experienced since the increased throughput allows for multiple devices to receive data at simultaneously. It is introducing orthogonal frequency-division multiple access which enables the splitting of a channel to enable multiple devices to receive different data. To handle that addition, the number of subcarriers are also going to be increased by a factor of four and the spacing of the subcarriers is decreased by the same factor.

2.4 GHz - IEEE 802.11b/g/n/ax

802.11b/g/n/ax are the sections of the 802.11 standard that are relevant to the frequency range of 2.4 GHz which we use for the transmission and reception of the drone controller. There are fourteen channels that are designated for the 2.4 GHz frequency with a spacing of 5 MHz between the start of each channel range. For North America, eleven of the fourteen channels can be used where the last three channels are not allowed. That means we are unable to utilize the frequency range of 2456 MHz - 2495 MHz, which are channels twelve through fourteen, and are limited to the frequency range of 2401 MHz - 2473 MHz, which is channels one through eleven.^[39]

Each channel's range overlaps the channels before and after ranges which can cause interference. To help alleviate interference, it is recommended that the channels used within close proximity of each other are separated to every fourth or fifth channel. The separation can result in none or a very minimal amount of frequencies to be shared among channels in use which also minimizes the change for interference.

5 GHz - IEEE 802.11a/h/j/n/ac/ax

802.11a/h/j/n/ac/ax are the sections of the 802.11 standard that are relevant to the frequency range of 5 GHz which we use for the transmission and reception of the video data. This frequency range has a vast increase in the restrictions for its channel use by the United States. The ranges of 5.25 GHz - 5.35 GHz and 5.47 GHz - 5.725 GHz are restricted to use only with dynamic frequency selection and transmit power control capabilities which is to decrease the interference with military applications and weather-radar. The frequency ranges that can be used

without restrictions in the United States are 5150 MHz - 5250 MHz and 5735 MHz - 5835 MHz.^[39]

4.2 Design Constraints

The following section will discuss design constraints for the Object Detection Drone. The economic, time, environmental, social, political, ethical, safety, manufacturability, and sustainability constraints will all be evaluated. Inclusion and analysis of the effects of federal and local regulations will also be considered in these constraints.

4.2.1 Economic and Time Constraints

Economic and time constraints played a factor in how we chose to design our Object Detection Drone. Due to the summer semester's 12 week length there was not as much time for design work as if we had a standard 16 week semester. Additionally, there are not very many sponsors if any at all during the summer which means all of the project expenses were out of pocket for our group. With the financial burden resting on the team's shoulders we had decided to save some design cost by developing our own drone chassis. The chassis is designed with common, cheap PVC. Any further mounts, cases, or protective covering are modeled or in the process of on an as needed basis. These models can then be 3D printed for use on the drone. By doing this we were able to save roughly \$50 - \$100 dollars on the frame alone.

Additional time constraints come in the form of individual obligations for each member of the group. The entire design has been developed through other course loads and jobs resulting in less than 100% time dedication to the Object Detection Drone. With an approaching deadline for a working solution by December of 2020 we will have to make sure to keep on track. Our development process and time to iron out any bugs or flaws will also be constrained by this same deadline.

4.2.2 Environmental, Social, and Political Constraints

Environmental constraints were addressed earlier in the standards section above. Overall, our team has decided that during the design process we will aim to recycle any electronic waste product through the appropriate avenues.

As drones are becoming more and more popular as recreational hobbies, they are also slowly becoming more accepted by the general population. However, there is still animosity towards drones and privacy concerns regarding them. Peoples apprehension towards drones as well as Florida wiretapping laws puts a social design constraint on our project. To utilize computer vision for object detection we will need onboard video capture. This onboard video camera is the

Mobius Action Camera as dictated in section 3 parts selection. The Mobius also records audio, therefore to meet this social design constraint the audio will have to be disabled on the camera before testing the system.

In regards to aviation rules and regulations the Federal Aviation Administration (FAA) is the go to source. With drones becoming more popular and more reported incidents, the FAA has in the last decade authored many new regulations. These regulations impose political constraints on the Object Detection Drone. In title 14 chapter 1 subchapter f part 107 from the FAA covers all regulations on the general operation of unmanned aircraft systems. Within part 107 we would be defined as recreational flyers. This will affect our design as we must limit the flight altitude to under 400 feet in class G airspace. Additionally, for flying in other class airspace we will have to contact the air traffic control tower. Part 107 also dictates that the Object Detection Drone will have to be registered with FAA and the registration number be affixed and visible on the drone. Moving down a level to local regulations, the city of Orlando also poses political constraints on the design and development of the Object Detection Drone. Test flight anywhere with the city limits of Orlando requires a \$25 permit. This permit means we will be required to test outside of city limits.

4.2.3 Ethical, Health, and Safety Constraints

Operating a drone is not inherently unethical or dangerous, but there are some situations where these factors could pose design constraints. The Object Detection Drone will have a camera attached to it and therefore operation and testing will have to be conducted outside of areas where one might have the reasonable expectation of privacy. Examples would include backyards, phone booths, business areas, hotels, etc. A remote triggered toggle for the camera could be fitted to the drone, but is not a design choice we are considering.

From a safety standpoint the drone should be uncomplicated to operate. This means the controls should be intuitive for those who have flown a drone before. We have incorporated this into our design by utilizing a common form factor RC controller which many drones use. Additionally, when tuning flight parameters via the flight controllers firmware we will make the design respond in a reasonable way. Examples would include turning response and throttle response which will be configured, such that the drone is easy to control. By tuning these flight parameters we will be able to make a drone that is safer to fly and easier to operate. In regards to other safety aspects of the drone some discussion has taken place before in the standards section.

4.2.4 Manufacturability and Sustainability Constraints

Manufacturability of the drone and its subsystems is a key priority in our design. When considering manufacturability constraints from the beginning we had come

up with the idea of having a modular frame. The frame itself as well as the motor mounts and other frame pieces are made of easily sourced materials. The frame itself is made from PVC which can be found at almost any hardware store and has been a common building component since the mid 1900's. Our other frame pieces are all self manufactured with quick turn around times using 3D printing. Additionally, our design incorporates mostly large electronic components that have many alternatives as well. For instance, there are numerous brushless motor manufacturers. In the instance that our selected motor is no longer available our manufacturability will not be affected as we can find a substitute. Overall, our design from the beginning was focused on having a high manufacturability in order to overcome the common manufacturing constraints of broken, hard to source, and specialty components.

The lightweight nature of drones makes them very heavily based around plastics. In addition to plastics the basis of getting a drone in flight is a power hungry operation resulting in large batteries. Both of these tasks are in conflict with the sustainability of a drone and lead to particular design choices on our part to better address the sustainability constraints of our project. By designing our frame out of PVC we were able to have a lighter weight plastic frame and retain recyclability. As mentioned our design incorporates 3D printed components as well. In section 3.2.8.1 we discuss the differences in printable filaments. In our design we have decided to go with PLA as it is a bioplastic made from plants and is industrially compostable.

In regards to the sustainability of our power source, our design opts to use a rechargeable lithium polymer battery. The process of mining lithium is very environmentally impactful. If there were other alternative battery technologies with less of a sustainability cost then we would have preferred to use those instead. However, lithium polymer batteries are one of the only power sources that fit the criteria for the design of a remote controlled drone. Sustainability is important to us, so in order to be as least impactful as we could we made sure to only incorporate a lithium polymer battery that had a high recharge cycle count. In general lithium ion batteries typically get 300 to 500 cycles. In a high draw application, such as our Object Detection Drone this cycle count could be much less as the battery encounters more stress. The battery we chose has a manufacturer guarantee of at least 150 cycles.

5.0 Project Hardware Design Details

The following section will focus on the hardware design of our project and how it will be constructed. Each subsection will be categorized by the following: Drone Subsystem, Flight Subsystem, Power Subsystem, and Detection Subsystem.

5.1 Drone Subsystem

The Drone Subsystem describes the physical aspects of our drone. This mainly includes the frame and mounts the electronic components are attached to.

Deciding on the frame design for our drone was simple. Since our drone has to carry a camera as load, the best option is to use a multi motor frame design. Specifically with four motors; a quadcopter. This quadcopter design will offer great mobility over an area along with great camera control with it's vertical take-off and landing (VTOL) and hovering capabilities.

A quadcopters frame can take on five distinct shapes: True-X, Square, Hybrid X, H, and Stretched X ^[63]. While any shape could be used and made to work, choosing the best frame design based on our needs can help save material and weight while offering a good deal of strength.

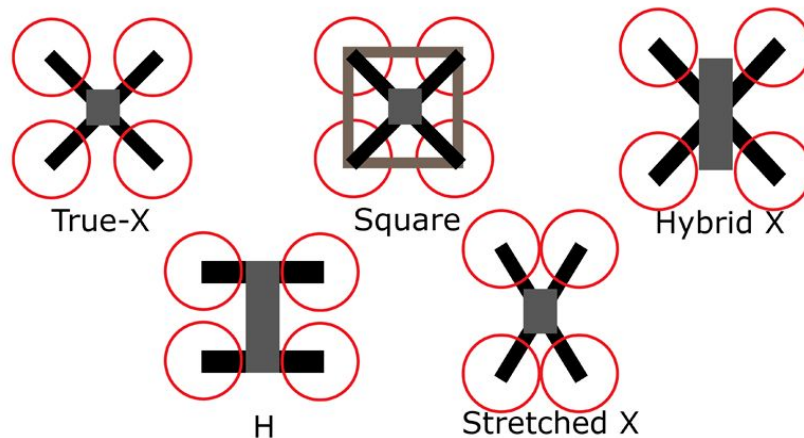

Figure 5.1: Common Quadcopter Frame Shapes (Permission Requested to Reproduce)

The True-X shape offers high torsional rigidity with low material weight. The Square is similar with additional support material to further increase rigidity but with the cost of added material weight. The H shape is heaviest, due its body size, and has problems with torsional stiffness. The others are hybrids of these two main shape designs and are more complex to build DIY, and therefore will not be used.

We have decided on incorporating the H shape design mainly due to its larger body size and its simple build. The larger size is necessary to mount our selected 3300 mah lipo battery, which is relatively long, along with other components.

5.1.1 Frame Material

The next step would be to decide on the material the frame will comprise of. As a group, we have decided to make the frame ourselves and will have it constructed mostly out of 1/2" Schedule 40 PVC with proper sized fittings. PVC pipes are strong, relatively lightweight, and cheap. The fittings also allows us to incorporate the two main frame designs easily. The cross fittings can be used to create the True-X structure, while Tee fittings can be used to create the H structure.

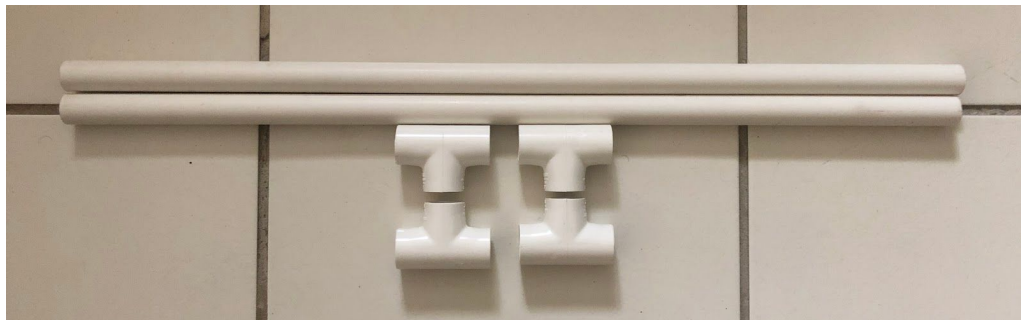

Figure 5.2: Two 2 Feet 1/2" Inch Sch 40 Pipes and 4 1/2"x1/2"x1/2" Tees

Selecting our frame material to be made out of PVC is a big reason why we chose the H shape design over the True-X shape. Although it may seem like weight and torsional stiffness is compromised by this decision, that is not the case in reality. The double horizontal bar design and tight connections of the PVC pipes and fittings are stiff enough for our needs. This only becomes a problem if our goal is to create a racing drone, where light weight and stiffness is top priority for speed, which ours is not. The objective that our frame needs to complete is to safely support the entire quadcopter to be flown smoothly across the sky as well as being cheap/easy to repair if accidental crashes were to occur.

5.1.2 Frame CAD

After choosing PVC as the material we want to build our quadcopter frame out of and choosing the H design shape, it is now time to convert it into a CAD model. Converting our sketches into a CAD model through SolidWorks will help us better visualize the project. It will also help us estimate the overall size and weight of our drone so our flight system hardware is optimally chosen. Modeling our drone will help us better plan and minimize building error even before physically obtaining the parts.

The figure below consists of 8 1/2" PVC cuts. The long vertical pipes are both 7 inches long. The remaining size horizontal pipes are 2 inches long.

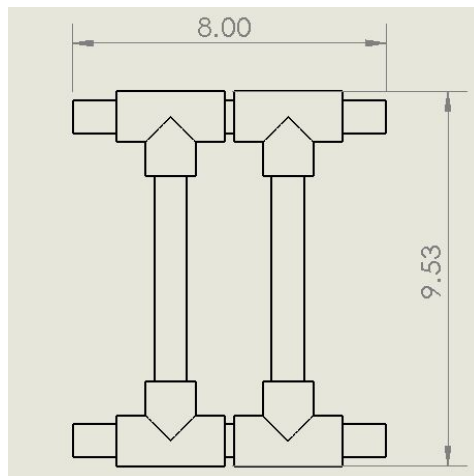

Figure 5.3: PVC H Frame Design Dimensions

5.1.3 Motor Mount CAD

The motor mounts were designed through SolidWorks to be 3D printed. It will mount at the ends of the PVC pipe arms in C-clamp manner and be tightened by Nylon nuts and bolts. The C-clamp design of the motor mounts were made to meet the modularity specification of our drone. It can be easily assembled and adjusted for proper motor balancing. It can also be easily removed which is beneficial for portability and replacement repairs. The long nylon bolts also serve as landing pillars further simplifying the design. The motor screw hole dimensions were taken via a GrabCAD model of the brushless motor.

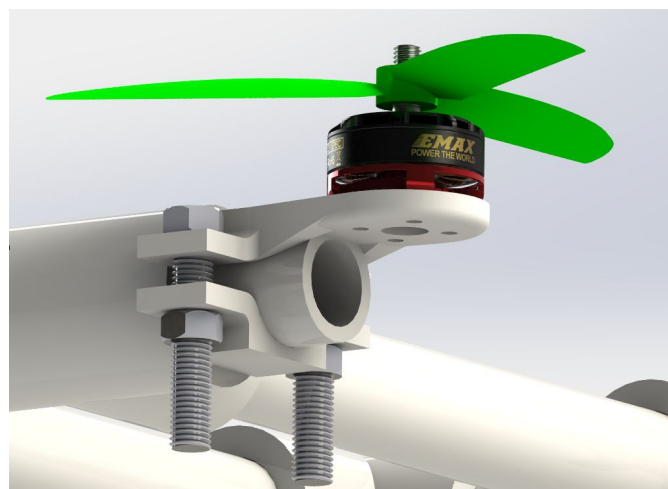

Figure 5.4: Motor Mount CAD

The below figure is a stress test analysis of our 3D printing motor mount. The green arrows are the fixture points. The purple arrows is 1kg of force representing the max thrust forces that is applied on the mount by the motors. As shown in the von Mises stress plot, most of the stress is concentrated where the bottom face is connected to the rib extrude, the weakest point. The rib extrusions were added to strengthen the entire mount and this is proven as highest stress concentrations, the red areas, are minimal.

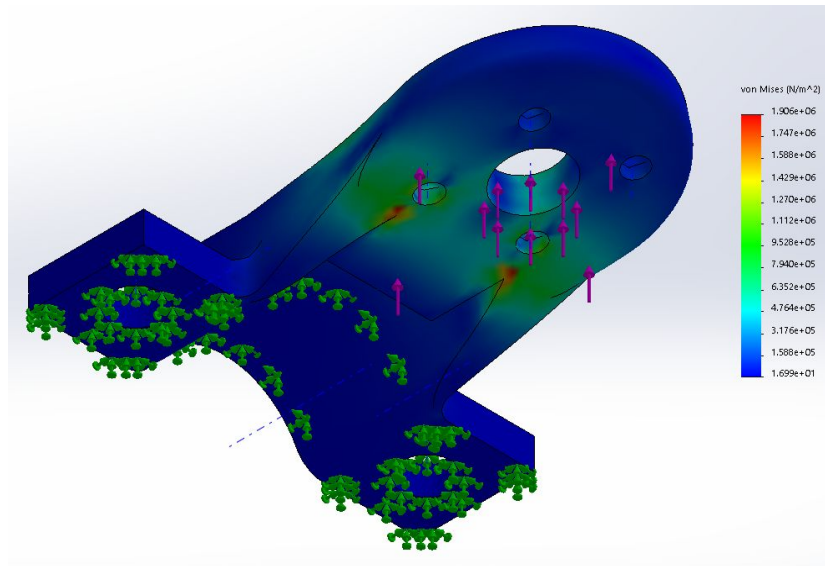

Figure 5.5: Stress Test Analysis

5.1.4 Body Component Placements

There are four major components that our drone must be able to carry within its body: the battery, camera, flight controller, and video transmitter. The biggest and heaviest component is the battery. The other components are placed depending on how the battery is placed. The battery can be top mounted or bottom mounted.

A top mounted battery configuration, usually requires two planes for the components to attach to. The planes are usually stacked plates separated via standoffs. The top plate holds the battery, while the bottom plate holds the rest of the components. Having a large mass above the propellers, this configuration will have a higher center of gravity (CoG). This could serve to be beneficial for the stability and responsiveness of a quadcopter due to having the CoG be closer to the center of thrust (CoT) - the intersection point of all the prop where the thrust is generated.

The bottom mounted battery configuration has the components mainly attached onto one plane. Components are attached both above and below this plane, with the battery attached below. This keeps the design simple and compact as there

is less top space required. This lowers the CoG of the drone which could cause the quadcopter to experience more rotational inertia causing less stable and agile flight.

The top mounted battery configuration was the chosen design for our drone because of its benefits of better flight stability and convenience. Having the battery top mounted allows easier access to the battery and requires less ground clearance for landing.

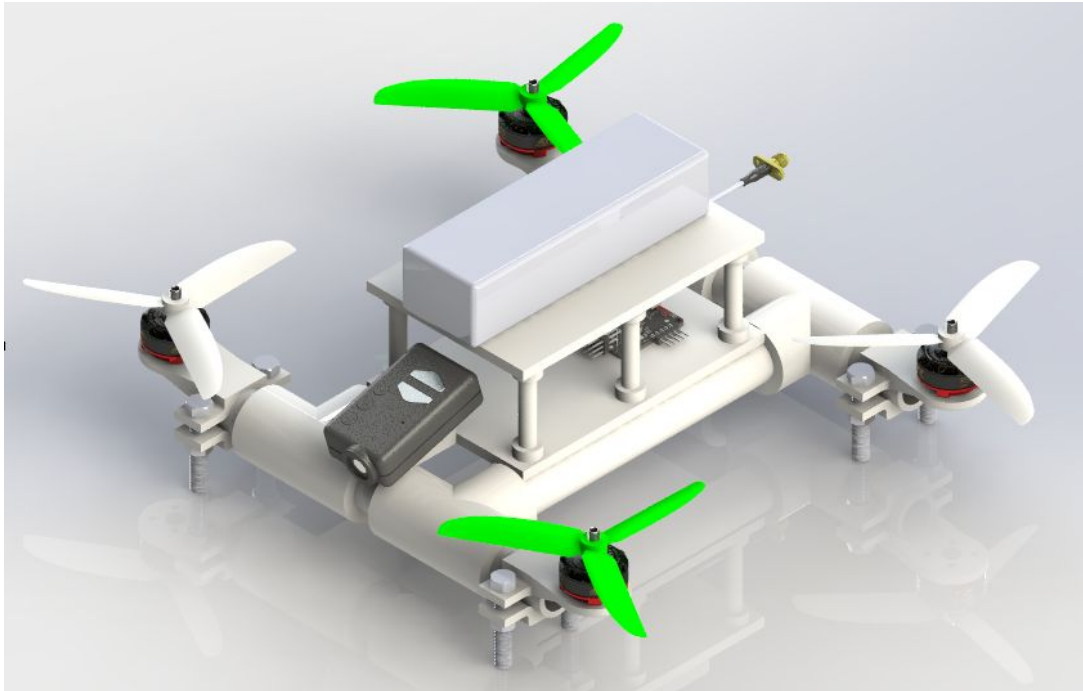

Figure 5.6: CAD Model of Our Top Mounted Battery Drone

The body plate will consist of two part prints. The lower plate will include the standoffs and angled camera mount located towards the front of the drone. The second part will be the top plate which will include extruded holes that the bottom plate standoffs will be inserted in.

The plan is for the base of the plate to be attached to the PVC pipes by either hot glue, screws, or a combination of both methods. The bottom plate standoffs will be glued and inserted into the extrusion holes of the top plate where the battery will be placed and held down by velcro waps. The Naze flight controller and video transmitter will be mounted on the top face of the bottom plate and bottom face of the top plate respectively with two sided foam tape. The two sided foam tape will act as an easy and cheap anti vibration mount for these components. Zip ties will be used to hold down any wiring to the body.

5.2 Flight Subsystem

Once the frame was decided, we must determine the hardware that will make up the flight system of our drone. This includes the flight controller, motors, and propellers.

5.2.1 Flight Controller

The Naze32 board's pinout offers a 3x6 header section to connect the ESC's signal servo to signal rail, 5V output rail, and ground rail. Moreover, a 10-pin section on one edge that can be used for various peripherals. These pins offer connectivity for RC input using PWM/PPM communication protocol, can be used to connect LED's, to connect RC input using SBUS protocol, and also offer soft-serial capabilities in case more UART connections may be required. Led connections can be useful as status indicators for various processes or simply for night-time visibility. When used as an indicator an LED can detect when the battery charge is getting low. This is extremely helpful as it helps avoid running out of battery while in-flight and crashing the drone.

One of the downsides of the Naze32 board is that with F1 processors, the use of UART1 port may cause a few issues, so avoiding using this port and using UART2 may be a better idea. If UART1 is in use, we are unable to use the USB port for board configuration. This is due to the fact that the UART1 port is also shared with the USB port. Moreover, the Fryskey telemetry pins also share UART1 with the USB port. This means to use Fryskey telemetry, we cannot use UART1 and vice versa. This is also true with Fryskey telemetry and the USB port. Instead, Fryskey telemetry can be moved to a soft-serial port.

This brings us to the last pin section on the Naze32. A pin section of 2x5 is available to use for a few specific peripherals. These pins can be used to setup Fryskey Telemetry, like mentioned earlier is not the best idea. It offers a 3.3V output with 100mA for smaller peripherals, a buzzer connection, an I2C port, and pads for battery voltage monitoring. Additionally, the board offers two sets of GPIO pins; one offers a 5V and the other 3.3V. These pins can come in handy when adding extra peripherals such as a sonar sensor requiring 5V.

Moreover, this flight controller is embedded with a 2MB of flash memory that can be used with a useful feature called Blackbox in the Cleanflight configurator application. Blackbox data logging can be used to help in tuning PID controls or other issues related to performance during flight. With that said, since the Naze32 only offers 2MB of flash storage for this use, only 3 to 4 minutes of flight time can be logged running at approximately 2.5kHz looptime. Conversely, the Acro version of the Naze32 does not contain these 2MB of flash storage. To use

Blackbox on the Acro version it would need an external data logger and an SD card. While this may mean more components are connected to the board, increasing weight and strain on the power system, more data can be logged on an external SD card with more storage.

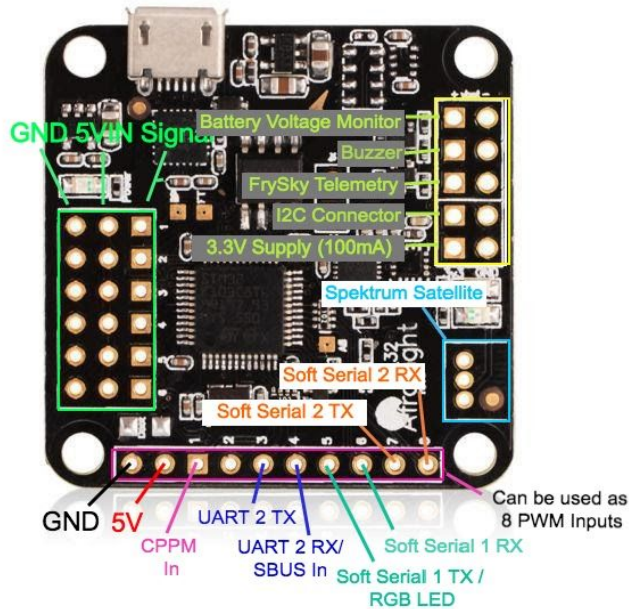

Figure 5.7: Naze32 Components

5.2.2 Flight Controller Breadboarding

Below is a demo where we ran one of the motors through our Naze32 flight controller. The flight controller is powered by a 5V power source (the breadboard) and the motor is powered by the lipo battery.

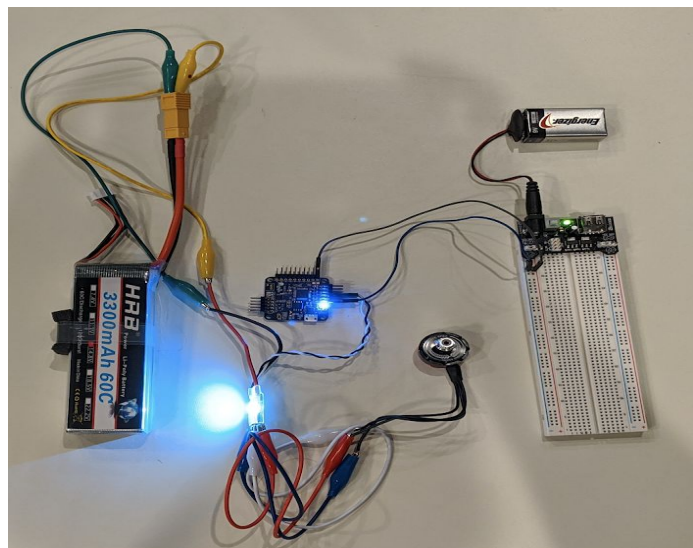

Figure 5.8: Lipo + FC + Motor Breadboard Demo

5.2.3 Motor and Propeller Thrust Calculations

Our motor thrust calculations with the HQProp are pending. Our calculations are based on *miniquadtestbench.com* test results for the EMAX and HQ v1s prop with a 4" pitch combination^[46]. We will be using a prop with a 3" pitch so it is expected to produce overall less thrust but also draw less current.

EMAX RS2205 S 2300 KV + HQ v1s 5X4X3			
	Thrusts (g)	Current (a)	Voltage
IDLE	27	0.74	16.05
25%	120	2.03	16.03
50%	369	6.05	15.95
75%	719	13.75	15.81
100%	1127	26	15.58
EMAX RS2205 S 2300 KV + HQProp Ethix S3 5x3.1x3			
IDLE	Pending	Pending	Pending
25%	Pending	Pending	Pending
50%	Pending	Pending	Pending
75%	Pending	Pending	Pending
100%	Pending	Pending	Pending

Table 5.1: Motor + Prop Thrust Calculations [46]

5.3 Power Subsystem

The Power Subsystem of our drone includes two main components: the power supply and a power distribution board. The functionality and details of these components are described below.

5.3.1 Power Supply

As evaluated in the parts selection section in 3.3.4 we chose the HRB 4S 14.8V 3300mAh lithium polymer battery as the power supply for the Object Detection Drone. Using this battery as our power platform allows us to achieve our desired flight time as well as sustain the power draw of all of the components. Originally we had used a guideline table to determine a rough idea on what battery to choose. In order to be confident in our power source's capabilities the design choice was modeled by calculations.

5.3.1.1 Flight Time Calculations

To ensure our power source design is to meet our engineering requirement of a 5 minute or greater flight and hover time we need two variables. The first is the capacity of the battery and the second is the total current draw of all of our components. We know the capacity of our battery is 3300 mAh, but to determine our current draw we will need to sum all of the components current draw.

Using the weight determined in table 5.2 of 945.20 grams and the fact that we are using 3.1 pitched tri-blade propellers we can determine the current draw of each motor. The current references are located in the manufacturer's datasheet for our EMAX RS2205-S motors. To determine the reference current we first need to calculate the thrust that each motor needs to produce for hovering. This can be done by simply dividing the gross weight of the drone by four. This comes out to roughly 237 grams of thrust per motor. In the manufacturer's reference we are told that the motor draws 5 amps per every 326 grams of thrust. Proportionally, we would be drawing close to 4 amps to reach our 237 grams per motor of thrust. The Mobius action camera can be run from a 5V USB cable. The standard for USB 2.0 states that a compliant port will be able to provide 500mA and testing shows that the Mobius while outputting video and not recording will draw about 250mA. The Naze32 flight controller also has a 5V input, but testing shows on average it draws only about 150 mA. The video transmitter at our intended use of 25mW setting draws a maximum of 120mA according to its data sheet. Our last major component, the FlySky receiver draws about 300mA. For our modeling since many of these figures are max draws or tested measurements during intended use we take the ratings at their face values .

Total Current = motor + receiver + video transmitter + flight controller + camera
 $16.82A = 4A \times 4 + 250mA + 120mA + 150mA + 300mA$

Our major components at hover will draw a total current of 16.82A. As discussed in the design of our flight system our use case results in primarily hovering. Using the lithium polymer battery's rated capacity of 3.3Ah we can determine that flight time as follows:

Flight Time = Battery Capacity / Total Current Draw x 60 (minutes per hour)
 $11.77 \text{ min} = 3.3Ah / 16.82A \times 60\text{min}$

Our calculations show that the power source is sufficient for roughly a 11.8 minute flight hover time which meets our engineering requirements.

5.3.1.2 Full Throttle Analysis

A quick glance at the manufacturer's reference table will show that the motors at full throttle can draw 33.6A. Given our quadcopter design this current will have to be multiplied by four resulting in a peak current draw at full throttle of 134.4A for the EMAX RS2205-S motors. The HRB 4S 14.8V 3300mAh lithium polymer battery has a 60C discharge rate. Therefore we can verify that our power source will be able to handle these bursts without damaging itself or other components.

Power Source Max Current = C-Rate x Capacity (Ah) / 1h
198A = 60C x 3.3A

The result of 198A gives our power source head room when under full throttle conditions of 134.4A load.

5.3.2 Power Distribution Board

One of the most critical components in a drone is the battery as it serves as the power source which will supply power to all components on the drone. We alter the size and weight of the drone in order to conserve the fuel and extend the flight time of a drone for a specific battery. The conservation of fuel through design changes is just as important as the right distribution and management of the battery. For this purpose, a Power Distribution Board is used.

The Power Distribution Board divides the electrical power feed into subsidiary circuits as well as provides a protective fuse and circuit breaker for the safety of the drone. Some Advanced Features use the Power Distribution board, ESC and Flight Controller Integrated with each other while also using an auto pilot, such as PIXHAWK PX4 version 2.4.8 which is rather expensive and exceeds the budget of our project. We are using a separate Power Distribution board, with the ESC and Flight Controller connected to it.

A PDB is a simple basic circuit board which connects all of the ground connectors to each other and connects all positive connectors to one another allowing specifically designed power flow to all of the components in the drone in an organized manner instead of having a birds nest of cables going between all the components.

Voltage Regulators are used on Power Distribution boards which are also known as Battery Eliminator Circuits (BEC). It regulates the voltage from 14.8V (in the case of a 4S Lipo) to 12V or 5V as per requirement.

It also regulates and channels the voltages coming from the battery. As we are using a 4S Lipo battery which will give us ~14.8 Volts, the power Distribution Board converts the 14.8V into 5V or 12V per the requirement of the component. The Main components which require power in a drone and power is delivered to through the Power distribution board will be the ESC for each motor, flight

controller, camera and the Receiver/Transmitter. This is very useful as otherwise all the components on the drone should be working on 14.8 V, i.e. the voltage delivered by the battery.

The power distribution board in our Object Detection Drone will be our own design including a 5V regulator. The design will distribute the power source for easy connections and clean wiring. It will be designed to withstand the large current ratings that can occur when the drone is in flight.

The PDB was designed in a way such that the ESC's can be connected to the pads on the PDB in an organized manner. This was done by placing two sets of solder pads for Vin and GND on either side of the board. That way the left side and right side can be connected to two ESC's each.

Moreover, an extra 5V output was added in the design for open-endedness with a set of solder pads (5V and GND) at the front of the boards.

5.3.2.1 Voltage Regulator Design

Here we can see the design schematic for our 5V voltage regulator. Moreover, an extra 5V output was added in the design for open-endedness with a set of solder pads (5V and GND) at the front of the boards. For our design we had decided to go with the switching voltage regulator TPS56339DDCR from Texas Instruments. This IC has a sustained current rating of 3A which is far higher than our 5V components draw requirement. Additionally, it can take a large input range from 4V to 24V. All of this can be accomplished while still boasting high efficiency ratings in the 90% regions.

During our design process we also saw many linear voltage regulators. However, when researching further it was clear to see that linear voltage regulators are much simpler to implement, but come at the cost of efficiency. This loss of efficiency was a design compromise we were not interested in making. Losing efficiency meant losing flight time in regards to our Object Detection Drone.

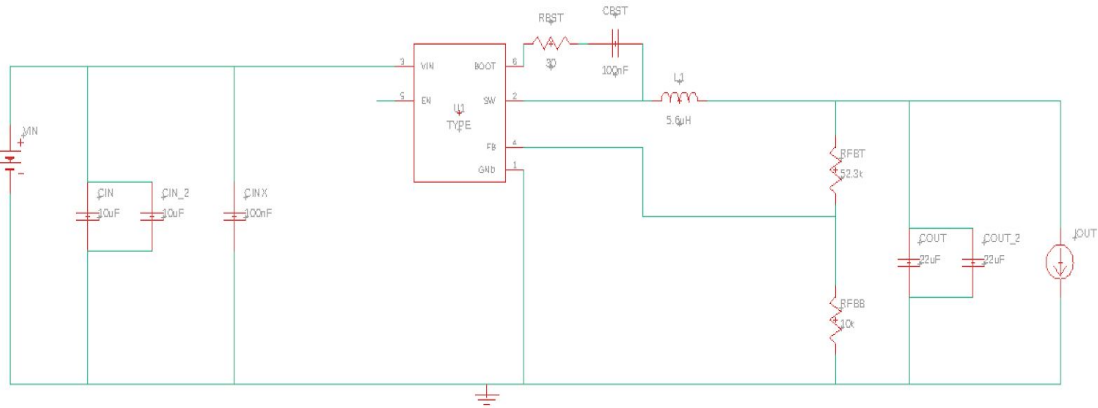

Figure 5.9: Voltage Regulator Schematic

Once we knew our design, we were able to order our parts. When the parts arrived we decided to test our designs functionality on a breadboard. An oversight on the ordering list left us with a very small IC voltage regulator and other SMDs. In the spirit of working with what we had, high gauge lead wires were carefully soldered to the pins of the TPS56339DDCR. This process was repeated with other electronic components that we did not have through-hole versions of. Care was taken to solder quickly and accurately in order to not burn out the components with high heat exposure.

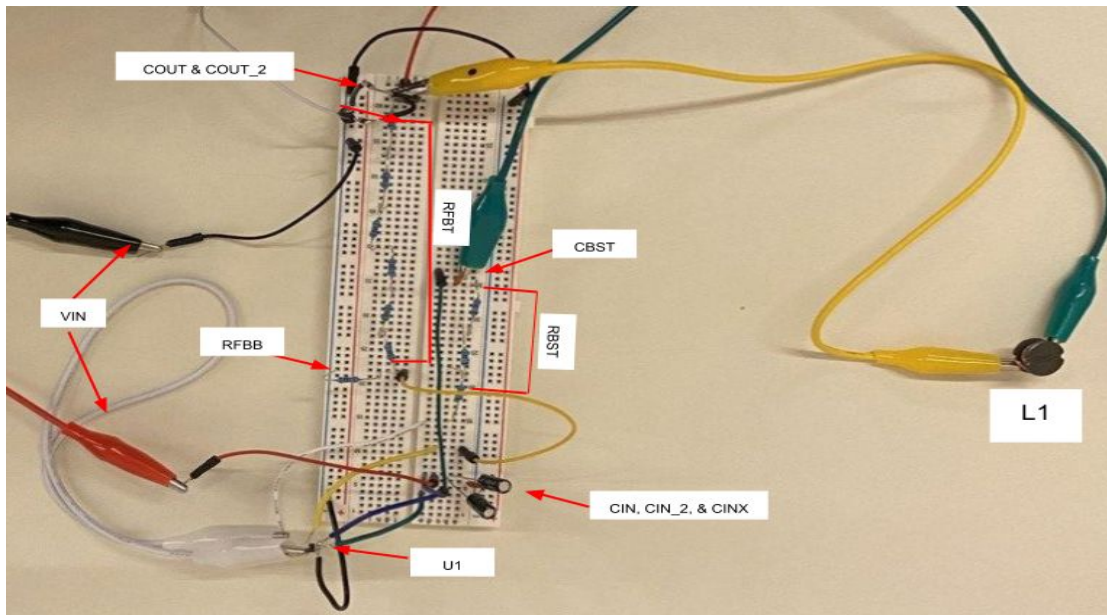

Figure 5.10: 5V Regulator Breadboard

5.4 Detection Subsystem

The following section will give an in depth look at the design of the camera system and how all of the components are connected. We will also discuss which components we chose for our project and why from the components we compared in an earlier section.

5.4.1 Camera

After the research we conducted to compare several options for the components of our camera system, we concluded on which we would use and how they would be used to make up our camera system. Our camera system will run independent from our drone system due to differences in the transmission frequency utilized to transmit the video signal and the transmission frequency utilized to transmit the controller signal to and from the drone. For the camera itself, we decided to go with the Mobius action camera that we researched in the camera selection section of this document.

The Mobius action camera meets our requirement of having a camera resolution of at least 1280 x 720 pixels by having a resolution of 1920 x 1080 pixels at thirty frames per second or a resolution of 1280 x 720 pixels at sixty frames per second. The Mobius action camera has the ability to utilize both resolutions and can be programmed to use our preferred resolution.^[27] Through testing we will determine which resolution we will utilize since both resolutions can affect the object detection time and accuracy.

The Mobius action camera also meets our physical requirements of the camera's size and weight. The Mobius action camera has a weight of one ounce which is not even one tenth of a pound which is well within our weight requirement for the drone. The size for the Mobius action camera of 1.38 x 2.4 x 0.72 inches provides a convenient size to have the ability to mount the camera to the bottom of the drone without having to worry about if it is too large.^[27]



Figure 5.11: Mobius Action Camera (Permission Granted to Reproduce)

The Mobius action camera does not have to be connected to the battery of the drone since the camera itself has an internal battery that can be charged and can stay charged for around eighty minutes. There is no official schematic for the Mobius action camera from the manufacturer that I could find. There is not one provided in the user manual or anywhere on any website from my research. The closest I could find is a picture of the board for the camera when it is removed from the casing.

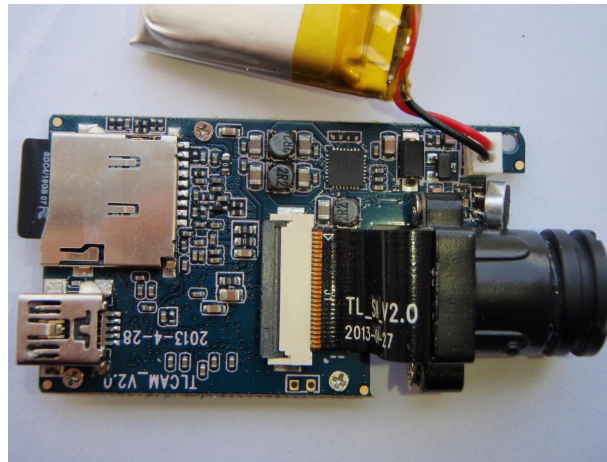

Figure 5.12: Inside of the Mobius Action Camera (Permission Granted to Reproduce)

The Mobius action camera does not have the ability to connect to the video transmitter with the contents that come with the purchase of the camera. The manufacturer of the camera also creates a breakout cable that you can connect to the camera which splits into different cables with the ability to connect them to a transmitter. This breakout cable can be modified to fit our needs to connect the camera to the video transmitter.



Figure 5.13: Mobius Action Camera Breakout Cable (Permission Requested to Reproduce)

This cable splits up the mini USB connection into three different connections, one for video output, one for audio output, and one for a voltage source. In the USB connector on the Mobius action camera, the manual states that the connector pin four is used as a sense pin and then the connector pin five is a ground pin.^[49] If

both of those pins are connected to each other, then the connector pin two will be switched by a builtin USB switch to be the video out pin and the connector pin three will also be switched to be the audio out pin. The breakout cable provides the needed connection to switch the USB connector pins and then also provides access to the cables which can be modified as needed to fit the video transmitter we decided on.

After we received the Mobius action camera, we wanted to test the camera with the breakout cable to verify that the two worked together as intended. To perform this, we decided to use a breadboard that we connected the camera to through the breakout cable to test the video out connection along with the five volts input to the camera.

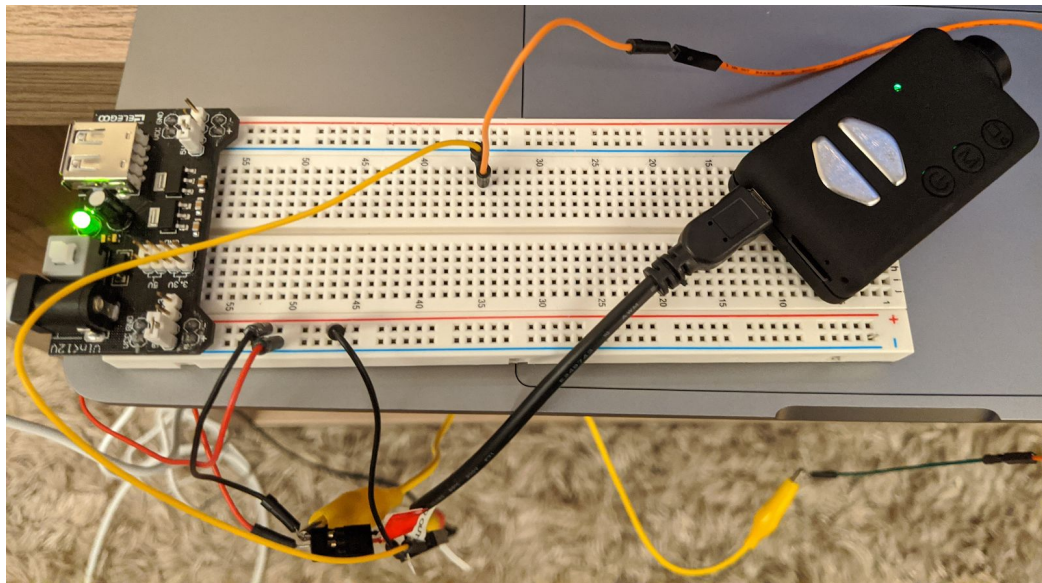

Figure 5.14: Mobius Action Camera with Breakout Cable and Breadboard

In the picture, the yellow wires are connected to the video out wire from the breakout cable, the red wire is connected to the five volts input, and the black wires are connected to the ground.

We then decided that the video transmitter that we will use for our project is the Eachine TX805 transmitter. This video transmitter provides an area to connect the wires from the Mobius action camera to the transmitter. Excluding the connections for the transmitters power, a voltage in and a ground connection, the connections that are provided are an audio in connection, a voltage in connection from the camera, a ground connection from the camera, and a video in connection. All of the connections will be soldered in place. The Eachine TX805 transmitter also includes a connection for an antenna built onto the transmitter where the antenna will be mounted.

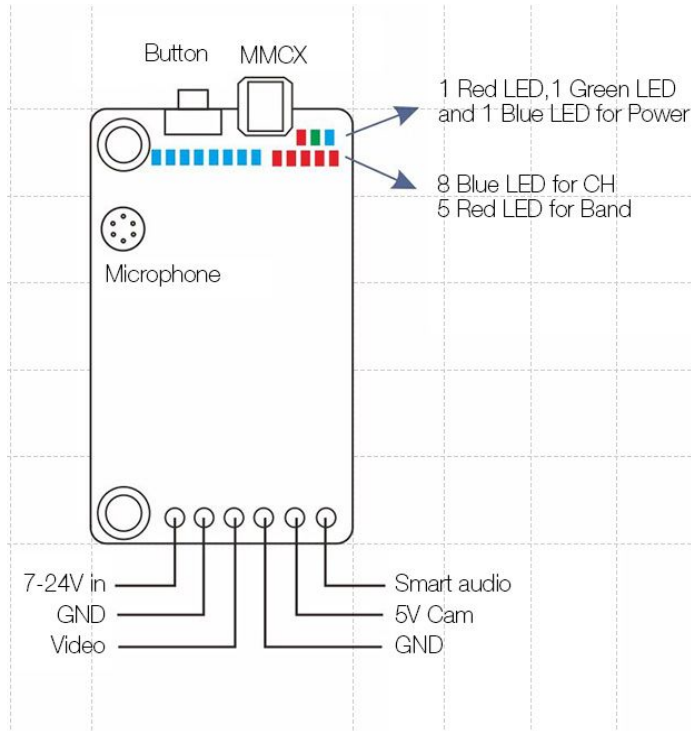

Figure 5.15: Eachine TX805 Schematic (Permission Requested to Reproduce)

If we connect all of these components together, the result is the entire design for our camera on our drone and the transmission of the video feed. This is what will be located on the drone.

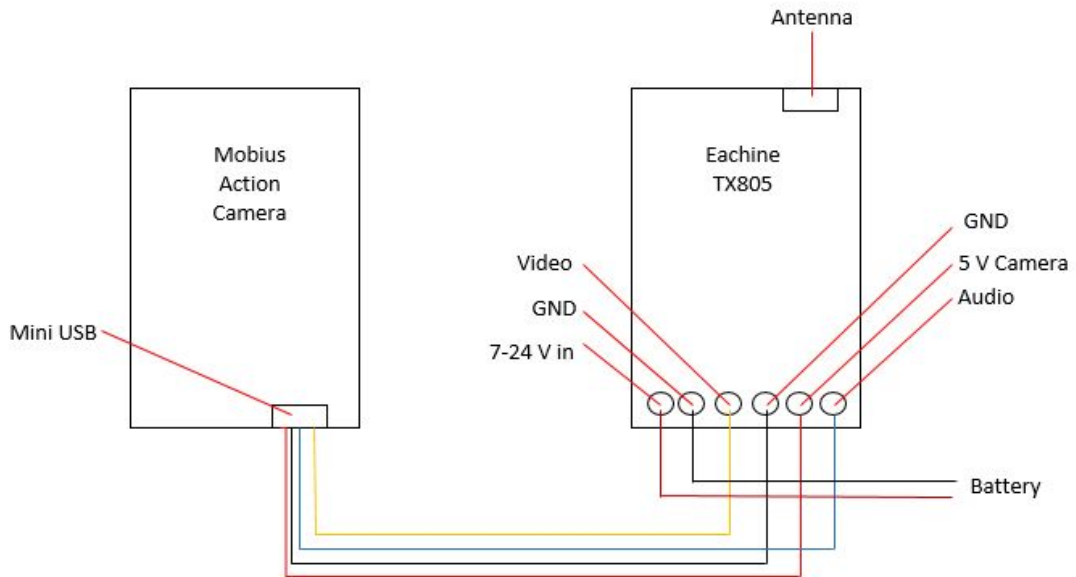

Figure 5.16: Camera System Design

5.4.2 Ground Control System Design

The following section will give an in-depth look at the design of the control system for the drone on the ground and how all of the components are connected. We will also discuss which components we chose for our project and why from the components we compared in an earlier section.

5.4.2.1 Remote Transmission

For transmitting and receiving the controls to the drone, we researched multiple different models and styles of drone controllers. After our research, we decided on using the Flysky FS-i6X controller with a matching receiver. The Flysky FS-i6X controller itself provides us with a choice of six to ten channels which we can utilize for different commands and other actions we would want to transmit to the drone. The controller uses a frequency of 2.4 GHz which should not interfere with our video transmitter signal.

The receiver that is included with the Flysky FS-i6X controller is the Flysky FS-iA6B receiver. The receiver provides the ability to receive six channels which is the lowest amount of channels that the controller is able to utilize. The Flysky FS-iA6B receiver also has the ability to receive a frequency in the range of 2.4055 GHz - 2.475 GHz which matches with the controller's frequency of 2.4 GHz.^[7] The receiver comes equipped with a dual antenna set up which assists with the combating of signal interference and helps provide a more stable signal connection.



Figure 5.17: Flysky FS-i6X Controller (left) and Flysky FS-iA6B Receiver (right) (Permission Requested to Reproduce)

We are able to connect the Flysky FS-iA6B receiver to the Naze32 flight controller that we chose. To be able to connect the two, we have to connect a cable that flows between the SBUS pin section on the Flysky FS-iA6B receiver

and some of the hole connections on the Naze32 flight controller. Below is a visualization of how the two will be wired together.

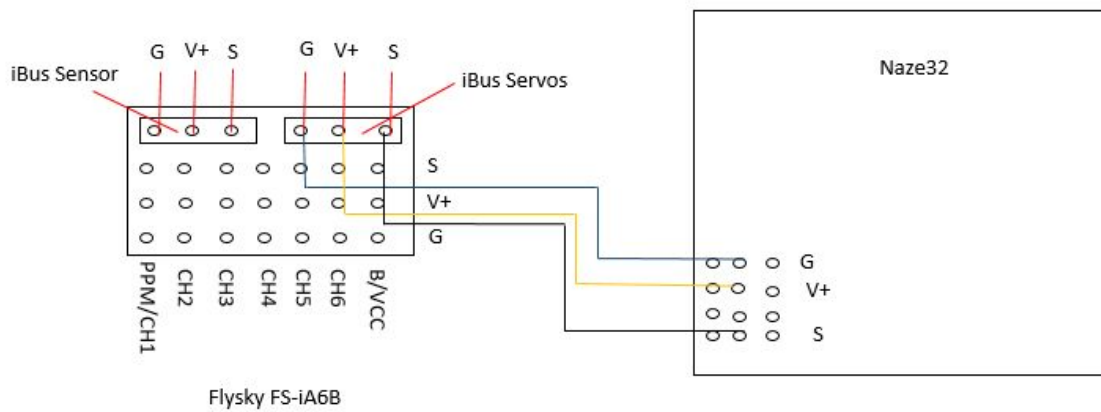

Figure 5.18: Drone Controller Receiver Connection Design

5.4.2.2 Video Receiving

For receiving the video feed from the drone, we researched multiple different video receivers that have the ability to connect to the phone of the pilot. The receiver that we decided to use for our project was the Eachine ROTG02 which we chose over the Eachine ROTG01 for the reason of having the second antenna connection which provides a greater stability to the signal compared to just one antenna connection. How we are going to connect the video receiver to the phone of the pilot is through a simple USB to mini USB or USB C cable with the USB connection on the receiver. Below is an example of the type of connection we are going to use.



Figure 5.19: Example of the Video Receiver and Phone Connection (Permission Requested to Reproduce)

5.5 Overall Component Mass

Item	Mass/Item	Amount	Total Mass (g)
1/2" PVC Tee	0.032lbs or 14.5g	4	58
1/2" x 2' PVC Pipe	0.16 lb/ft or 72.57 g/ft	26 inches	157.24
1/4" x 1-1/2" Nylon Hex Bolt + Nut Nylon 1/4	1.5g	4	6
3D Printed Motor Mounts (Assembly)	24g	4	96
3D Printed Body Plate Assembly	80g	1	80
EMAX RS2205-S 2300KV	30g	4	120
HQProp Ethix S3 Prop	3.6g	4	14.4
HRB 4S 3300mAh 14.8v Lipo RC Battery	330g	1	330
Mobius Camera	1.3oz or 36.85g	1	36.85
Naze32 Rev6 Full	10g	1	10
ESC	5.89g	4	23.56
Miscellaneous	50g	1	50
Total			945.20

Table 5.2: Overall Component Mass Table

5.6 System Overview

The following is a schematic based overview of the entire design.

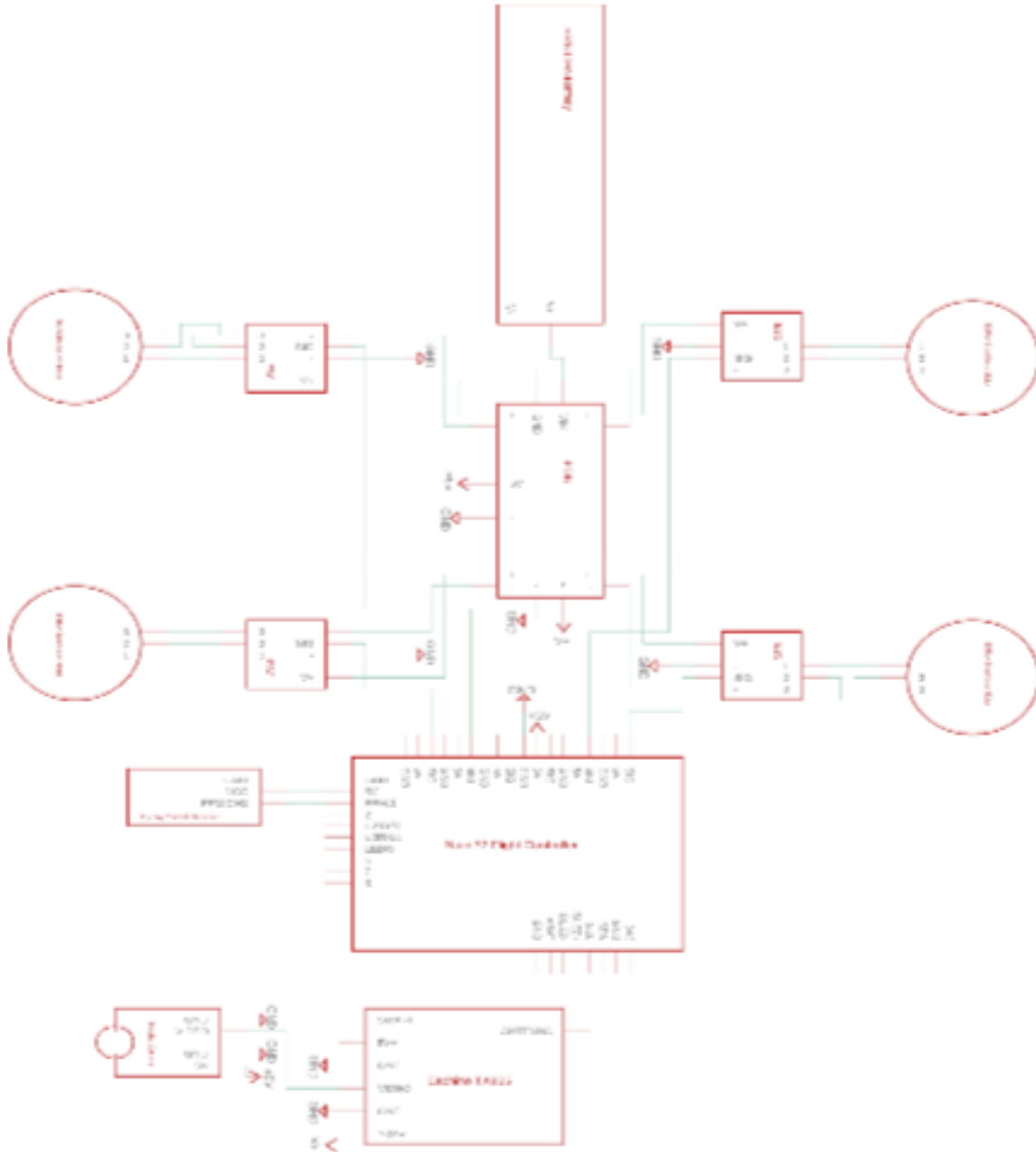

Figure 5.20: Overall Electronic Design Schematic

6.0 Project Software Design

The following section will go over the design regarding the software aspects of the Object Detection Drone. The largest component of which is the pilot application. There are additional software aspects in regards to configuring the flight controllers firmware as well as tuning parameters for flight performance.

6.1 Mobile Application

Discussion regarding the design of the mobile pilot companion app will follow. Topics such as the intended development environment, target platform, methodologies, and design paths will be covered.

6.1.1 Development Environment and Platform

The pilot companion application is intended to be developed for a mobile Android device. This design choice was due to the analysis of both the iOS and Android platforms in section 3 relevant technologies. Some specific advantages include the ability for unrestricted side loading of applications, the lower cost of a developer account for the Google Play Store, and the openness to development hardware. These advantages made the choice a no brainer as our team would have an easier time testing and developing without having to worry about work arounds. Overall, we preferred the lower barrier to entry that Android development poses.

In order to develop applications for the Android operating system we need access to the Android SDK. The Android SDK is a software development kit that provides access to the underlying features of Android, such as system calls, drawing geometry to the screen of a device, accessing files, etc. The Android SDK can be downloaded as a standalone software for development purposes, but it also comes packaged with Android Studio IDE. Android Studio is a full fledged Integrated Development Environment and our choice for development environment. Using Android Studio provides our team a uniform development environment which in turn will allow members working on the pilot companion app to collaborate efficiently. Additionally, Android Studio provides many useful specialty features and tools. A great example of one of these tools is emulators. These emulators will allow a developer to mimic a fully featured Android device on their computer. This reduces development costs as to test for functionality amongst devices we can emulate instead of purchasing them.

There is more than one programming language supported by Android Studio. This leaves us with the option of using Java, Kotlin, C++, C#, and many other popular programming languages. However, the official language for Android development is Java and that is what we will develop in. By using Java we will

have access to a wide range of online forums, tutorials, and documentations regarding developing applications for an Android system. In addition to this wide range of information, most of our team has experience with Java from previous courses.

6.1.2 Pilot Companion Application Design

6.1.2.1 System Overview and Use Case

The pilot companion application is intended to provide a live view video stream to the pilot. This video stream will come from the drone's camera through the Eachine TX805 video transmitter and to the phone via the Eachine ROTG02 5.8G Video Receiver. If object detection is toggled once the video is received by the phone a machine learning model based on the popular real time YOLO algorithm will analyze the frames in order to detect objects. These objects will be represented to the pilot with bounding boxes and class labels. Additionally, smaller features like object counts will also be available in the application. Below we can see this interaction modeled.

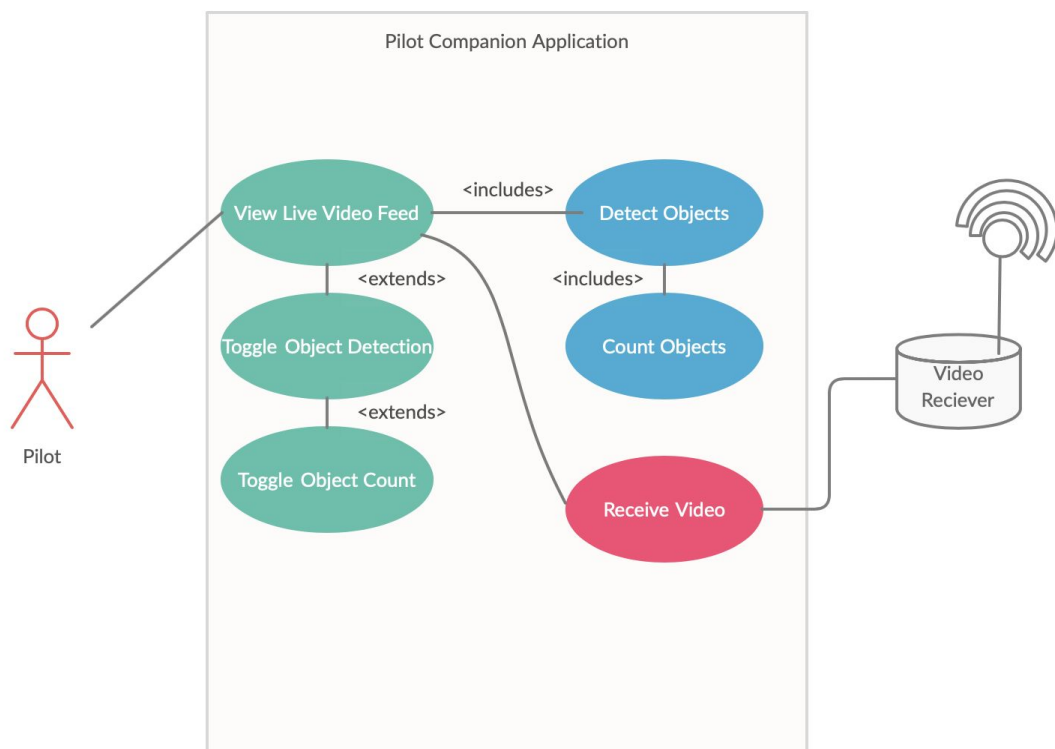

Figure 6.1: Pilot Companion App Use Case

6.1.2.2 Class Structure

With a better understanding about how the pilot utilizes the companion app and the flow of data, we can discuss the architecture necessary to support these functions. Classes are a very important concept of object oriented programming and are how we will implement the pilot companion apps functionality. In Java classes are the programmer's defined prototypes that can be used to make objects. The pilot companion app will need a GUI class for interfacing with the user. This class will be instantiated when the application is launched and will take care of the positions of on screen objects, such as toggles, options, and the frame that the live view video feed resides in. To communicate the frames to the detection algorithm a video handler class will be necessary. It will take care of any connection establishment or preprocessing for the video. Additionally, a detector class will be necessary and will accept the frame data and run a version of a YOLO-like algorithm to detect the objects in each frame. The YOLO algorithm was discussed in section 3. The detector class would also have fields to toggle certain behaviours like keeping a count of objects. These classes and their interactions can be seen modeled below in figure.

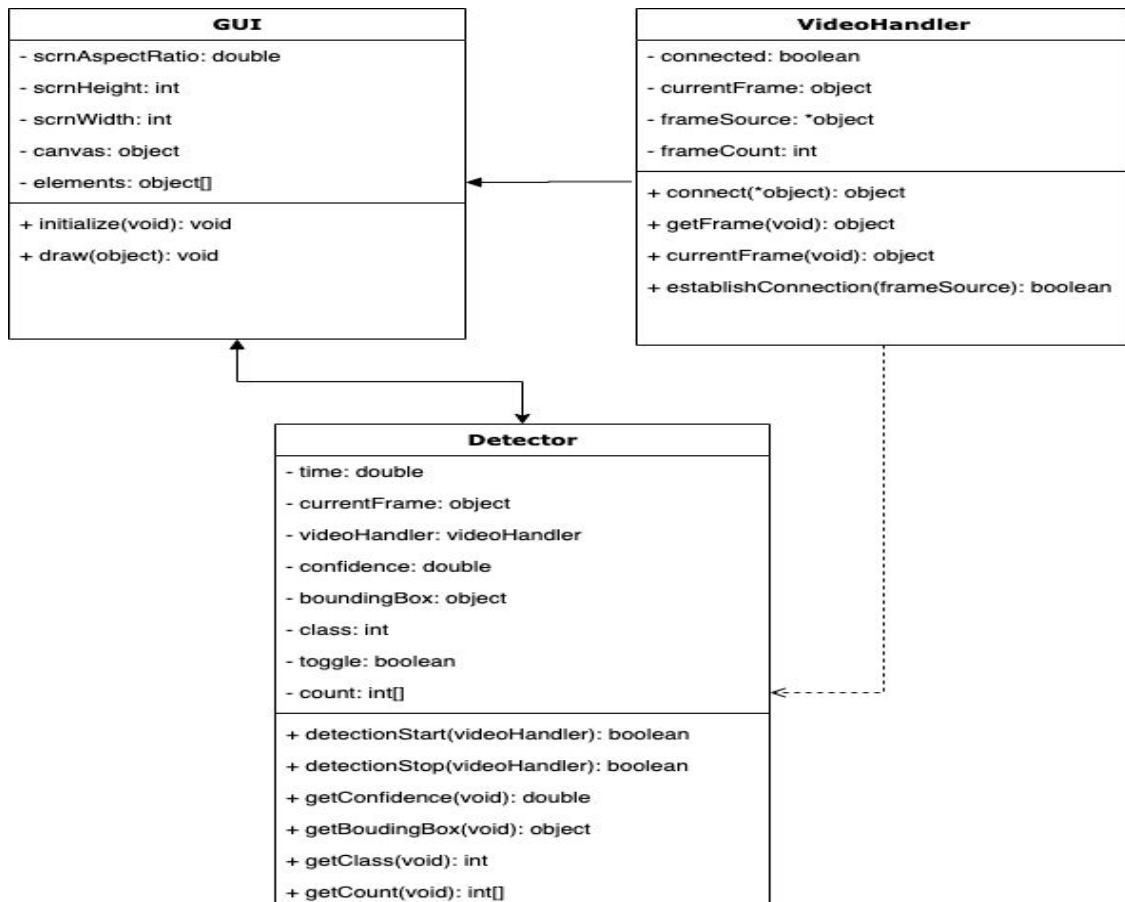

Figure 6.2: Pilot Companion App Class Diagram

6.1.2.3 GUI Design

Designing a good GUI is equally as important as the software itself. In order to provide intuitive user experience our app needs to be more than just a command line interface and video feed. Without ease of use the application will be cumbersome and painful. This will inevitably result in the scientific aspects of the design being disregarded. In order to avoid such a situation we have designed an agnostic mockup for the pilot companion application's GUI. The designed GUI will be a viable solution regardless of the course of the backend development.

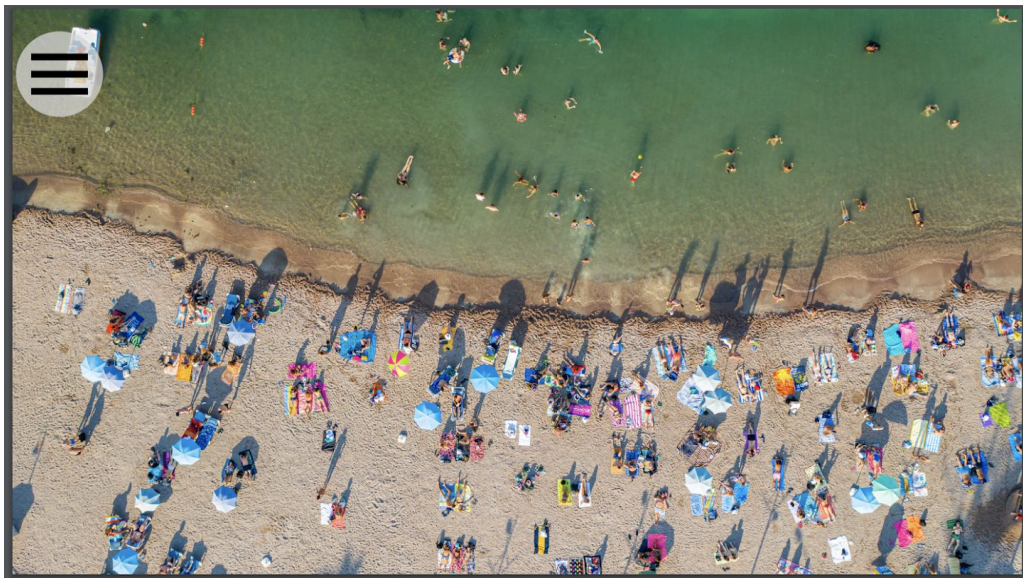

Figure 6.3: GUI Home Screen (background: unsplash x)

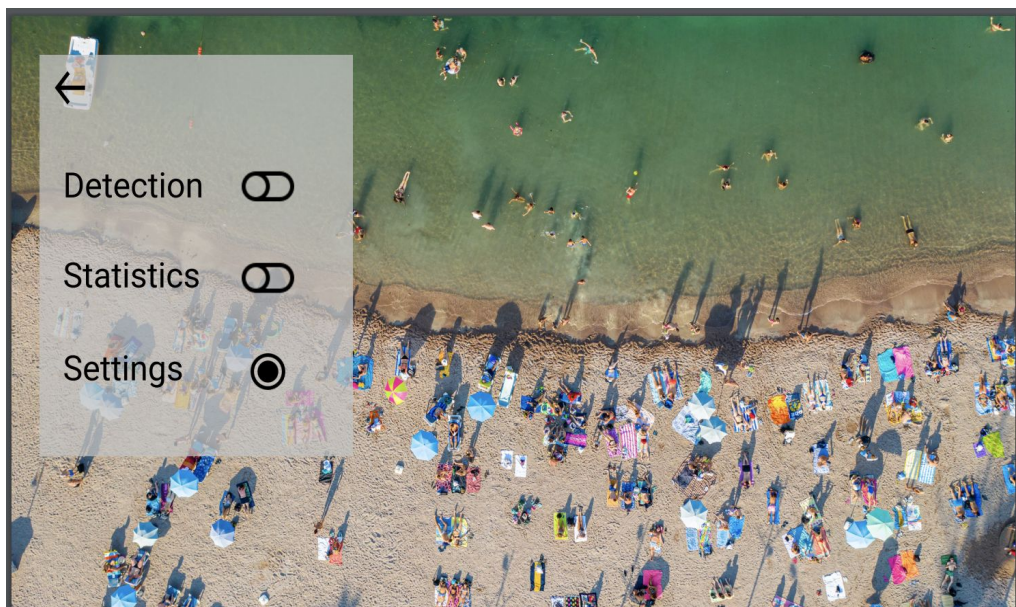

Figure 6.4: GUI Menu Screen (unsplash x)



Figure 6.5: GUI Detection and Stats Screen (unsplash x)

6.1.3 Pilot Companion Application Development Paths

6.1.3.1 Path 1: Manufacturer Driver

Our first potential path in the development of the pilot companion application involves utilizing the Eachine ROTG02 5.8G Video Receiver's driver. This would allow direct access to the receiver on a hardware basis. We could directly access either the frame buffer or some form of onboard memory in order to fetch the frames. This would be our ideal approach. However, the manufacturer does not provide the driver on the products webpage. Our current goal is to get into contact with Eachine and ask them if they could provide us a driver. Additionally, if the driver cannot be provided we will also request if they have a software developer kit. Understanding that it is likely they will not divulge this information freely we are also accepting of any tools they may be able to provide, even if in a stripped down capacity.

In the case that we can get our hands on some form of tool, the pilot companion application would be able to have very fine control over the video receiver. In terms of algorithmic design we would be able to initialize the device and collect its output directly. Here is an overview of how our applications algorithm would work in the case that object detection is currently running.

- START
- Initialize GUI
 - Initialize Receiver
 - Display Receiver Frames On Screen

- Toggle Detection “On” in Menu
- Detector Takes Receiver Frames
 - Edits Frame w/ Bounding Box and Class
 - Sends Frame to be Drawn by GUI
- Repeat Till Condition or Exit
- END

This results in a very clean and concise implementation of the required functionality. As previously mentioned, this is our preferred development path. In the worst case and possibly more likely case that Eachine does not provide us with any tooling, drivers, etc. There is an apk or Android Package file on the products page. This apk file is essentially a third party app that we can download onto our test Android phone and run with their hardware. Alternative development paths utilizing this apk will be analyzed.

6.1.3.2 Path 2: Overlay Application

An alternative method is to utilize the apk file located on the product page as well as Android system features. Android has permission settings to allow apps to draw over other apps. This means that images, buttons, text, and many other functionalities appear to float over any other open app. These “floating” elements still have all the same functionality. Additionally, this permission allows drawin to the screen. This would allow us to keep the exact same GUI. The difference for this development path would be that the Eachine app will have to be downloaded and run before we run our pilot companion app. While the Eachine app is outputting video to the screen our app can be run overtop of it. This would give an effect of an overlay. Another Android system feature we would utilize is screen recording. By combining both of these methods we would still be able to implement the same functionality. The algorithm would change in the following ways.

- START
- Run Eachine Application
 - BlackBox Details
 - Initialize Receiver
 - Display Receiver Frames On Screen
- Run Pilot Companion App
 - GUI Initialized as Overlay on Top of Eachine App
- Toggle Detection “On” in Menu
- Detector Reads Android Device Screen Frames
 - Calculates Bounding Box and Class
 - Sends Bounding Boxes and Class to be Drawn by GUI
- Repeat Till Condition or Exit
- END

This results in a slightly more obfuscated implementation of the required functionality. This is not our first choice method, but does accomplish the same goals and utilizes well documented features of the Android system.

6.1.3.3 Path 3: Reverse Engineering

The final development consideration is reverse engineering the provided apk file. This poses no legal troubles as there are no laws expressly banning the decompilation of software. However from a copyright perspective this could pose issues, but it is to be noted we are only reverse engineering as a means of learning how to access the hardware and no code will be expressly copied. Additionally, the application will not be a paid application if it were to be publicly available. Now that our intentions are very clear we can further analyze this development path.

Decompiling software is not specific to the Android platform and has been done in many different domains and with many different languages. It is to our benefit that in this case scenario we would likely be decompiling Java bytecode since the apk is an Android based application. Java compiles to a bytecode that is then run by the Java Virtual Machine (JVM). Usually, bytecode is more likely to have a higher success of decompilation to something useful. There are numerous tools that can help us with this process, such as reverse engineering apk tools, java decompilers, etc.

Overall, this is our last choice for a development path. However, from an algorithmic standpoint once we know how our device communicates with the Eachine video receiver we should be able to simply reproduce our first algorithm as if we had the tools provided by Eachine.

6.2 Firmware Tuning

Many of our hardware components have updateable firmwares. This allows us to pick and choose for better support and features. The most configurable firmware is for our Naze32 flight controller board. This board has many different firmwares from different developers. With so many options there are a plethora of new features, bug fixes, and beta access features. However, we chose Cleanflight as our flight controller firmware. This section will go over some of the tuning features available in Cleanflight.

6.2.1 PID Tuning with Cleanflight

Not every flight controller is the same and this leads to small error values known as drift. Drift is when the onboard flight controller sensors, such as the accelerometer are being read too sensitively. This means even though the flight

controller is stationary, the accelerometer could be reading a slight motion or drift in a given direction. These drifts are a result of small errors in the PID loop. PID stands for proportional integral derivative controller. It is a sensor loop that takes a target value and current value calculating errors between these two values in an attempt to correct behaviour towards the target value. These corrections when not properly calibrated or tuned can come in the form of undershooting and overshooting. In the circumstances of undershooting a correction, the system will be sluggish to respond. In the instance of our flight controller it is possible the control signals would not respond quick enough to correct in midair, thus causing a crash. On the other hand, overshooting takes form in constant over corrections. In a drone it would be observed as jittering, because the PID loop consistently overcorrects.

To fix these errors Cleanflight provides a command line interface allowing tuning of the PID parameters. In their documentation they describe tuning the P, I, and D parameter and what is affected when each parameter is adjusted. The following is an excerpt from their documentation:

“**The P term** controls the strength of the correction that is applied to bring the craft toward the target angle or rotation rate. If the P term is too low, the craft will be difficult to control as it won't respond quickly enough to keep itself stable. If it is set too high, the craft will rapidly oscillate/shake as it continually overshoots its target.

The I term corrects small, long term errors. If it is set too low, the craft's attitude will slowly drift. If it is set too high, the craft will oscillate (but with slower oscillations than with P being set too high).

The D term attempts to increase system stability by monitoring the rate of change in the error. If the error is rapidly converging to zero, the D term causes the strength of the correction to be backed off in order to avoid overshooting the target.” [69]

There are many other configurable and programmable settings within the flight controllers firmware. We plan on exploring them as necessary to further improve our designs response and features.

7.0 Project Prototype and Testing Plan

This section encompasses the prototyping, hardware and software testing aspects of our project. The PCB manufacturing details will be discussed here. Additionally, the test procedures for each hardware component can be found in this section including results for functionality as well as proper performance.

7.1 PCB Prototype and Sourcing

To create the Power Distribution Board, Autodesk's Eagle software was used to create the schematic of the circuit, then afterwards the design of the printed circuit board (PCB). Before getting started with the design, however, the libraries for each specific component had to be searched for since Eagle did not always have all the parts available. Websites like ultralibrarian and SnapEDA were used to acquire these library folders. These libraries are added to the Eagle design project and are saved. These are very useful since all the details on the component are included in the libraries which allow us to actually purchase the design.

Most library folders offer the name of the component, the value, the tolerance (heat, voltage), a footprint, size of the component, and a symbol which can be used for schematics to represent the component, and finally PCB version of the component to be used in PCB design.

After adding the libraries for the components we needed, the schematic design was drawn and exported to a .brd file to start working on the PCB. A two layer PCB was implemented to fully utilize the board. Six solder pads were added at the input terminal providing six terminals for VBAT (battery voltage). Moreover, the IC TPS56339DDCR was chosen as our voltage regulator design; this was obtained from Texas Instruments' Webench Power Designer. The design handles 8-18V input voltage to provide an output of 5V at 3A. Since we are using a 4S Li-Po cell battery, our input voltage VBAT should be 14.8V which works with our design. A smaller solder pad was placed and connected to the output of our circuit to provide us with a 5V output.

The VBAT pads and their grounds will be used for the ESC's and the video transmitter. That being said, they require a high current draw. Therefore to increase efficiency of the conductance and alleviate the board heating up, 30 mil copper trace was connected to each of the input VBAT pads and their corresponding ground connection pads. For the same reason, for the smaller pads outputting the 5V and its corresponding ground pad, 20 mil copper trace was used. The rest of the board uses copper traces of 0.01 mil width, since current drawn by the surface-mount components is relatively small.

To avoid issues with increased impedance due to narrow or acute angles when adding copper traces, all copper traces were connected at obtuse angles, this would also help keep the board cooler. Furthermore, some components could not be routed without crossing over other copper traces, this where Vias come into play. Vias are represented on the PCB design by small blue holes. Their functionality allows us to extend a copper trace from our top layer, down to the bottom layer through a conductive hole that is drilled into the hole. In our case the vias are approximately 28.8 mil in diameter.

There are different types of connections that can be made through a via. First one is Through-hole via. This connects traces from the surface of one layer to the surface of another layer (under or above). Second type is the Blind Vias. This is seen in PCB's with more than three layers. It can connect a trace from the surface of a layer to the surface of a layer that is internal and cannot be seen. For example, in a three layer PCB, that would be from the top to middle layer - or bottom to middle layer. The third type are the Buried Vias. These vias cannot usually be seen as they connect traces from one internal layer to another. This is usually implemented in PCB's with four layers or more. Lastly, there are the Microvias. These holes are drilled with a laser into a copper contact creating smaller via holes than the other types. This is usually used in High-Density Interconnection (HDI) PCB's . Microvias can be classified into three different types: Stacked, Staggered, and Skipvias. Stacked vias are piled on top of each other in different layers. Staggered vias are scattered in different layers, this usually increases production price. Finally, Skipvias are used when a connection needs to be made from one layer to a layer that is one or more layers away, allowing it to skip layers without creating any electrical connection with said layers. In our case with a two layer PCB, Through vias were used to simplify connections between components.

Moreover, a good practice when designing PCB's is to create copper planes. Not only does this provide a reliable connection between components and pads, it can act as a heat sink, spreading heat away from components and plastics. It can aid in more efficient conductivity when speed and frequency of signals matters, helps reduce the possibility of the board warping, and reduces the amount of etching needed in the PCB fabrications process. In the case of our PCB, the top layer was traced with a copper plane to provide a ground signal, and a copper plane on the bottom layer to provide the battery input signal (VBAT). This has been an increasingly sought after practice not only to provide efficiency for the circuitry, but is also aesthetically pleasing - which people use to their advantage when trying to make a board look nicer and more organized.

After finalizing the design on Eagle, the ERC (Electrical Rule Check) and DRC (Design Rule Check) were used to check for any discrepancies in the design, errors and warnings. The DRC tool is very useful when designing the PCB as

you can set the values wanted for width between traces, holes, pads and other things on the board that may cause issues when manufacturing the PCB.

To be able to send the PCB design to a vendor, the most commonly accepted method is by using the Gerber file format. Eagle makes it simple by providing a zip folder entailing three files - one including the bill of materials, one including the various layers of the boards, and the last file includes the drill information for the board (size, location, etc.). This is done by accessing File -> CAM Processor... This will show details about the different layers to fabricating the PCB, and certain aspects of it that you can modify. Top/Bottom Copper layer, Top/Bottom Silkscreen layer, Top/Bottom Soldermask layer, Top/Bottom Solderpaste layer, board profile, and the drilling details.

These gerber files were exported and were sent to the Advanced Circuits company. The company usually offers a free quote, however they have recently been unavailable to provide that specific service. On the contrary, a DFM (Design for Manufacturability) report was received stating the board is free of issues (No showstoppers, No problems they had to automatically fix).

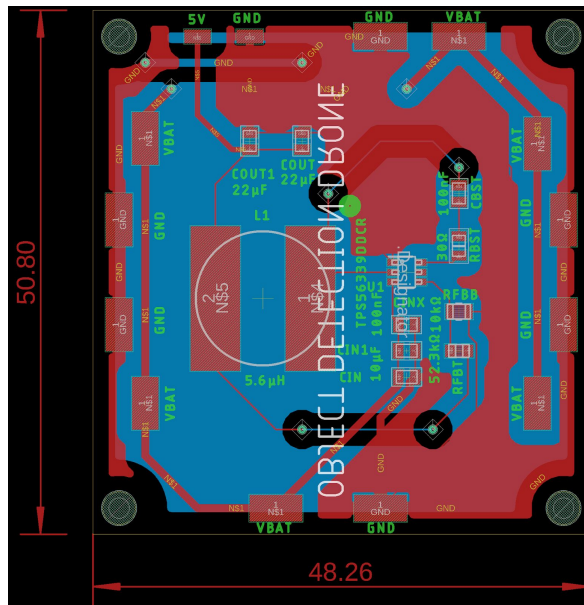

Figure 7.1: PCB Design on Eagle

Congratulations!

No DFM problems were found on your board!

Show Stoppers

We Found None!

Problems Automatically Fixed by FreeDFM

We Found None!

Figure 7.2: Design for Manufacturability (DFM) Report

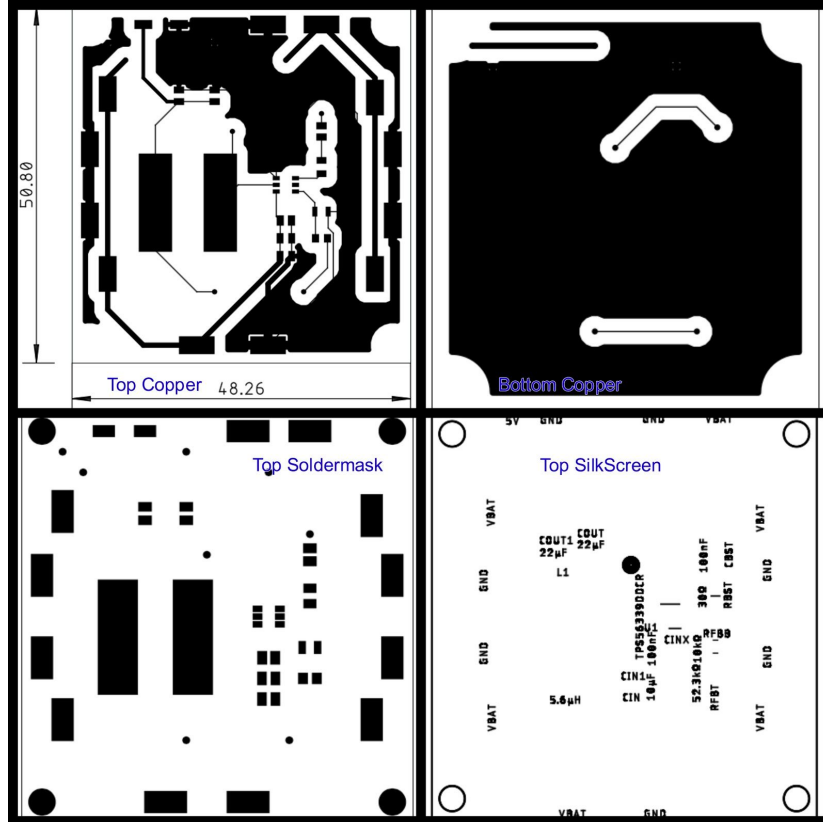

Figure 7.3: Gerber Files Returned from Manufacturer

7.2 3D Printing

The Ender 3 3D printer will be used to create our drones motor mounts and body plate. PLA is the material chosen to print with because of its ease to work with and its current availability. The cooling fans will be turned on as PLA produces the best results when properly cooled.

The Ender 3 printer is also capable of printing with ABS and Pet-g and could be used for future prints. The table below shows the main print settings used with PLA.

Print Setting	Value
Layer Height	0.2mm
Infill Density	20%
Printing Temperature	200 C
Build Plate Temperature	50 C

Table 7.1: Ender 3 Print Settings

7.2.1 Motor Mount Prototype

Prototype motor mount with motor and propellor affixed. The design of which can be found in section 5.



Figure 7.4: Motor Mount Prototype

7.3 Hardware Test Environment

Due to the lack of access to actual testing labs located at UCF during the Summer 2020 semester. A temporary lab was established at a team member's home. All tests including temperature were conducted at room temperature. The equipment and software used during test procedures include the following:

Testing Equipment

- Analog Discovery 2: 100MS/s USB Oscilloscope, Logic Analyzer and Variable Power Supply by Digilent
- QW-MS305D 30V 5A Adjustable DC Stabilizer Power Supply
- Cen-Tech 7 Function Digital Multimeter
- HK 936 Electronic Soldering Station
- AMES Instruments Infrared Thermometer 12:1
- Ryobi D43 3/8 in Corded Drill 1600RPM

Testing Software

- Waveforms by Digilent
- LTSpice
- AutoDesk EAGLE

7.4 Hardware Specific Testing

7.4.1 Motors

7.4.1.1 Internal Shorts or Damaged Windings Test

Objective: The objective of testing the motors is to ensure their proper functionality and safety. This test will use the generative properties of the motors when a mechanical force is spinning the motor. Measurements of generated voltage across terminal pairs will be utilized to determine if internal coil winds are damaged.

Environment: The motor hardware testing will take place in the environment described in section 7.3. The Ryobi D43 $\frac{3}{8}$ in Corded Drill 1600RPM, Cen-Tech 7 Function Digital Multimeter, and Analog Discovery 2: 100MS/s USB Oscilloscope, Logic Analyzer and Variable Power Supply by Digilent will be utilized in this test procedure.

Procedure: To test the motors for proper functionality and safety the procedure is as follows:

- 1) Start by connecting two terminals of the three terminals located on the motor to a voltmeter set to AC, making sure to keep the terminal connections isolated from each other.
- 2) Attach the drill chuck to the motor shaft.
- 3) Drive the motor with the drill at a speed of 1600RPM for 30 seconds.
- 4) Take note of the AC voltage reading produced by the motor while being driven by the drill.
- 5) Stop the drill.
- 6) Connect the voltmeter leads to two other terminal pairs. There are three total combinations of pairings. Terminals 1,2 ; 1,3; and 2,3.
- 7) Repeat steps 2 through 6 until no more pairs are available.
- 8) Repeat steps 1 through 7 until no more motors are left to test.

Results:

Motor	Terminal Pair Tests (AC rms)	Duration	Driving RPM
Motor 1	1,2 = 455 mV 2,3 = 467 mV 3,1 = 469 mV	30 seconds	1600 rpm
Motor 2	1,2 = 462 mV 2,3 = 458 mV 3,1 = 469 mV	30 seconds	1600 rpm
Motor 3	1,2 = 462 mV 2,3 = 466 mV 1,3 = 470 mV	30 seconds	1600 rpm
Motor 4	1,2 = 463 mV 2,3 = 466 mV 3,1 = 469 mV	30 seconds	1600 rpm

Table 7.2: Motor Generation Test

Conclusion: If the measurements for each terminal pair are similar than the motors have passed the test. In our results we can see that each motor on average was within $\pm 7\text{mV}$. During researching this testing procedure discrepancies of large values close to 100mV were present for known failed motors.

7.4.1.2. Broken Magnets or High Friction Test

Objective: The objective of testing the motors is to ensure their proper functionality and safety. This test will use an external mechanical force to spin the motors. The temperature of the motors will be measured throughout the test to make sure an overheat condition is not reached.

Environment: The motor hardware testing will take place in the environment described in section 7.3. The Ryobi D43 $\frac{3}{8}$ in Corded Drill 1600RPM and AMES Instruments Infrared Thermometer 12:1 will be utilized in this test procedure.

Procedure: To test the motors for proper functionality and safety the procedure is as follows:

- 1) Take the temperature of the inner coils of the motor at ambient temperature and note it.
- 2) Attach the drill chuck to the motor shaft.
- 3) Drive the motor with the drill at a speed of 1600RPM for 90 seconds.
- 4) Stop the drill.
- 5) Take the temperature of the inner coils of the motor after the test and note it.

6) Repeat steps 1 through 5 until no more motors are left to test.

Results:

Motor	Starting Temperature (Fahrenheit)	Ending Temperature (Fahrenheit)	Duration	Driving RPM
Motor 1	78	84	90 seconds	1600 rpm
Motor 2	76	82	90 seconds	1600 rpm
Motor 3	77	80	90 seconds	1600 rpm
Motor 4	77	83	90 seconds	1600 rpm

Table 7.3: Motor Temperature Test Results

Conclusion: If the during the procedure the motors do not make noises unrelated to operation (grinding, metallic, etc.) and do not become hot then they are safe to operate and free of defects, such as dislodged magnets or internal frictions and shorts. Our motors only increased in temperature by a few degrees and were not hot to the touch deeming them passed.

7.4.2 ESC

7.4.2.1 Output Waveform Test

Objective: The objective of testing the electronic speed controllers is to ensure their proper functionality and safety. This test will provide an input signal using the DShot600 protocol from the motor controller pin on the Naze32 board.

Environment: The ESC hardware testing will take place in the environment described in section 7.3. The Analog Discovery 2: 100MS/s USB Oscilloscope, Logic Analyzer and Variable Power Supply by Digilent and QW-MS305D 30V 5A Adjustable DC Stabilizer Power Supply will be utilized in this test procedure.

Procedure: To test the ESC for proper functionality the procedure is as follows:

- 1) Start by connecting the ESC to the power supply and set the voltage to the nominal voltage of the power source. In our case the nominal voltage is 14.8V.
- 2) Connect the control wire from the Naze32 flight controller to the control line on the ESC.
- 3) Connect the 3 terminals on the ESC to the terminals on one of the brushless EMAX motors.
- 4) In the Cleanflight software set the motor driver output to 2100.

- 5) Using the Analog Discovery 2 or another oscilloscope to measure three terminal outputs of the ESC.
- 6) Record the results.
- 7) Repeat steps 1 through 6 for each ESC for verification.

Results:

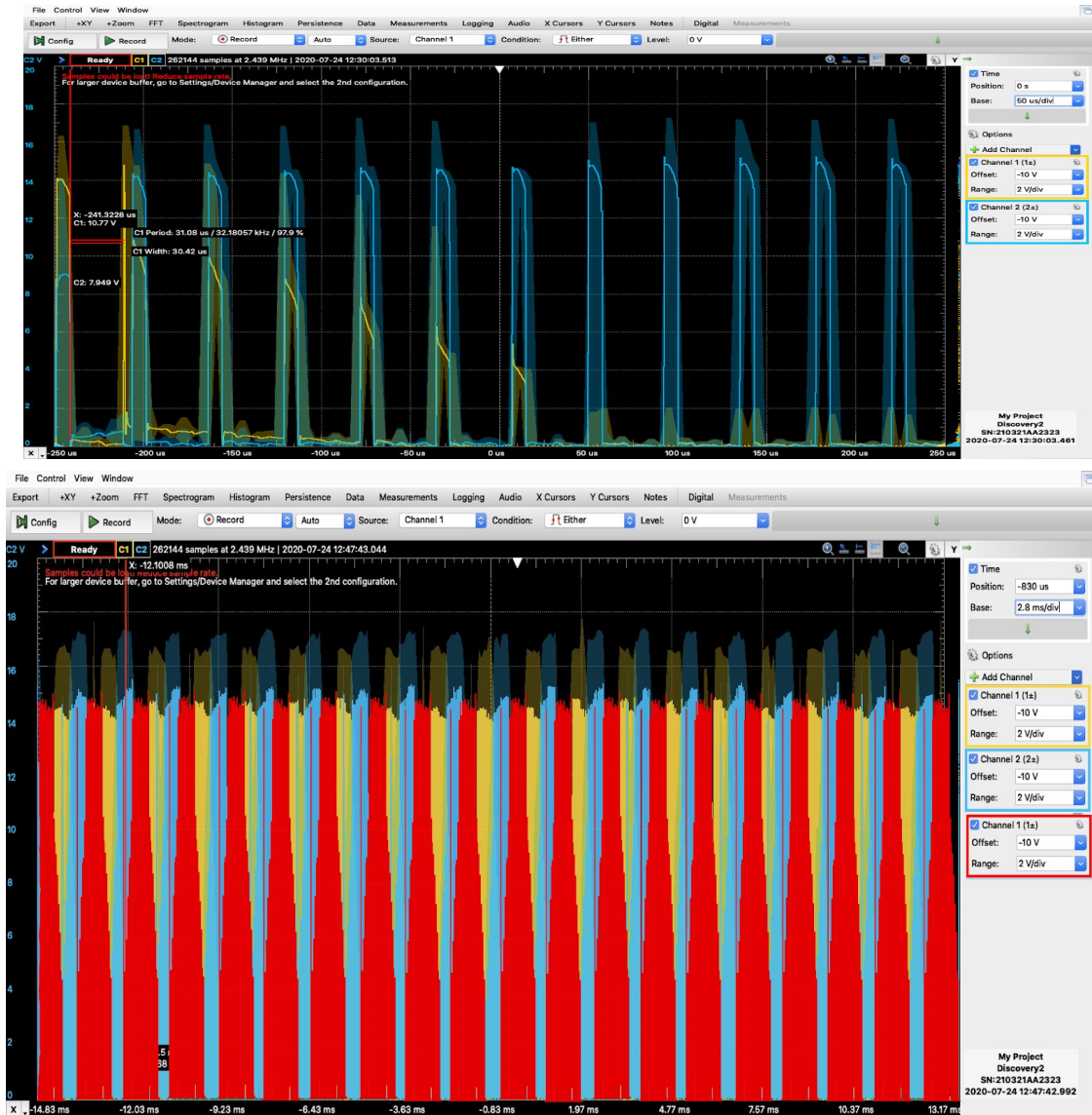

Figure 7.5: ESC Waveform Output

Conclusion: If during the procedure the phases can be seen and the motor is operating as intended then the ESC can be deemed operational. Some further analysis of the photos can tell more about the ESC operation. In the first output figure we can see the constant duty cycle in both the blue and yellow waveform. This corresponds with the test procedure as we have set a constant output of 2100 in Cleanflight. Additionally, in the first figure it can be seen where the output transitions from one section of the motor to the next where the yellow wave form

drops out and the blue waveform takes precedence. In figure 2 we can see all three phases of the motor and their overlap. As one section of the magnets in the motor are activated another deactivates thus spinning the motor. All of these measurements are indicative of a properly functioning ESC.

7.4.3 Flight Controller

7.4.3.1 Power on Recognition Test

Objective: The objective of testing the Naze32 flight controller board is to verify basic functionality. This test is simple power on test that includes attaching the controller to a PC and validating Cleanflight firmware is operational.

Environment: The Naze32 hardware testing will take place in the environment described in section 7.3. A computer and Cen-Tech 7 Function Digital Multimeter will be utilized.

Procedure: To test the Naze32 for basic functionality the procedure is as follows:

- 1) Start by connecting the Naze32 flight controller board to a PC.
- 2) Verify 5V power is good via multimeter and power indicator.
- 3) Launch the Cleanflight application.
- 4) Check that the Naze32 flight controller is recognized by Cleanflight.

Results:

Test	Expected (V)	Measured (V)	Recognized
Power	5.0	4.92	N/a
Recognition	N/a	N/a	Yes

Table 7.4: Flight Controller Power On Recognition Test Results

Conclusion: If during the procedure a stable 5V power line can be verified with a multimeter and the Naze32 flight controller is recognized in the Cleanflight software, basic functionality can be verified. As can be seen in results both criteria were accomplished and our Naze32 flight controller can be considered verified working.

7.4.4 Camera

7.4.4.1 Video Signal Test

Objective: The objective of testing the camera video output is to ensure their proper functionality and signal integrity. This test will analyze the composite video signal from the Mobius camera.

Environment: The Mobius hardware testing will take place in the environment described in section 7.3. The Analog Discovery 2: 100MS/s USB Oscilloscope, Logic Analyzer and Variable Power Supply by Digilent and QW-MS305D 30V 5A Adjustable DC Stabilizer Power Supply will be utilized in this test procedure.

Procedure: To test the camera for proper functionality the procedure is as follows:

- 1) Start by connecting the Mobius break out power and video cable to the camera.
- 2) Connect the power and ground to the power supply and set the voltage to 5V.
- 3) Turn the Mobius camera on.
- 4) Probe the composite video signal wire with the Analog Discovery 2 or another oscilloscope.
- 5) Record the results.

Results:

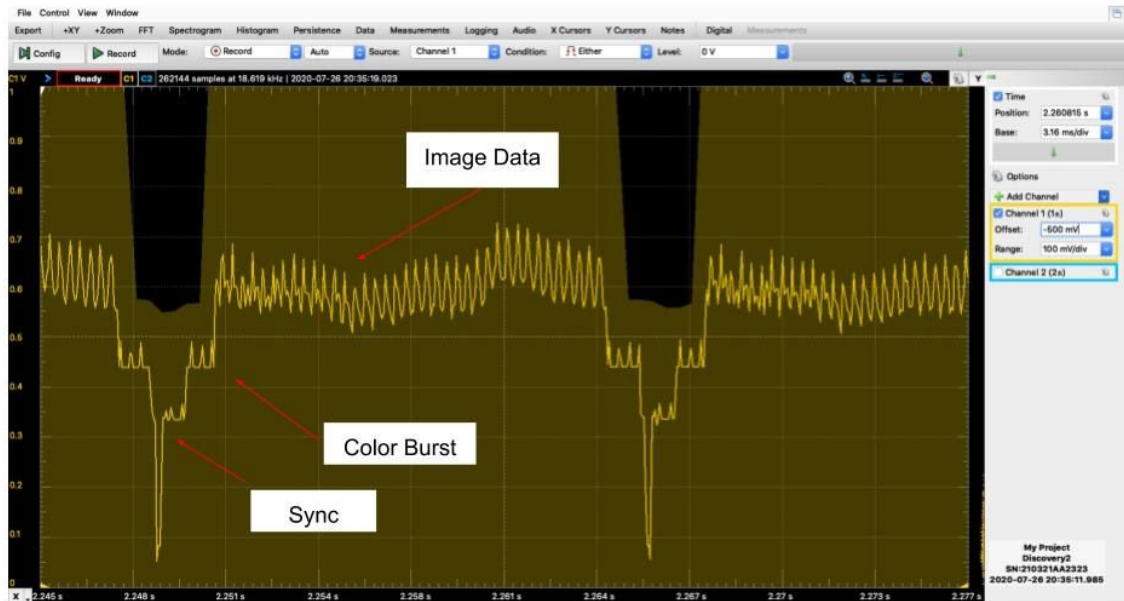

Figure 7.6: Camera Video Signal Test Result

Conclusion: If during the procedure a standard composite signal can be captured on the oscilloscope then the camera's output is functioning. However during testing the camera would not stay powered on. Test data could be gathered for a duration and video output could be achieved during testing, but soon the camera would turn off. Overall, we concluded the camera passed the composite output test, but is obviously not fully functioning as intended.

7.4.5 Remote Control Transmitter and Receiver

7.4.5.1 Remote Controller TX/RX Test

Objective: The objective of testing the FlySky remote control transmitter and receiver is to verify functionality.

Environment: The FlySky RC hardware testing will take place in the environment described in section 7.3. The Analog Discovery 2: 100MS/s USB Oscilloscope, Logic Analyzer and Variable Power Supply by Digilent and QW-MS305D 30V 5A Adjustable DC Stabilizer Power Supply will be utilized in this test procedure.

Procedure: To test the RC for proper functionality the procedure is as follows:

- 1) Ensure battery power for the controller is supplied in the form of four AA batteries.
- 2) Connect the power and ground to the RC receiver power supply and set the voltage to 5V.
- 3) If the RC transmitter and receiver are not paired, proceed to pair them. Otherwise, skip this step.
- 4) Connect the CPPM wire to the Naze32 flight controller.
- 5) Open the Cleanflight software and navigate to controller configuration.
- 6) View the RC transmitter input maps.
- 7) Modulate throttle, yaw, and roll verifying that the input mapping is being processed in Cleanflight.
- 8) Record the results.

Results:

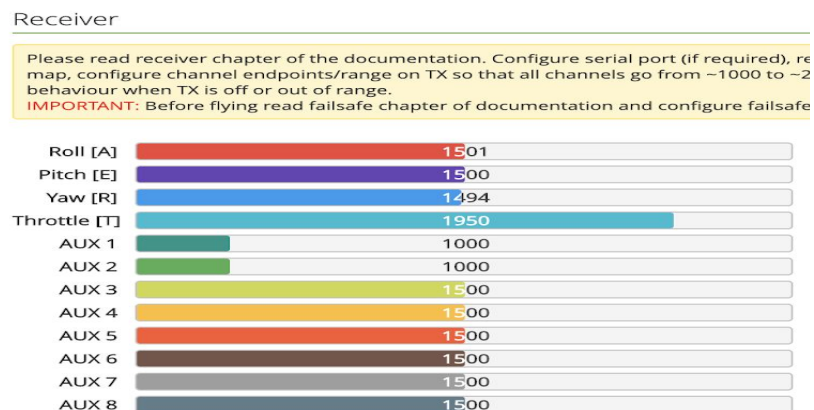

Figure 7.7: Remote Controller TX/RX Test Result

Conclusion: If during the procedure input can be verified via the input mapping tool provided in Cleanflight then the transmitter is operational. We can see in our

results that most of the transmitters control signals are defaulted at 1500. However max throttle was indicated on the RC control transmitter as well as AUX 1 and AUX 2 at minimum. In Cleanflight we see that the max throttle is read at 1950 Cleanflights maximum is 2000. Additionally, our two AUX controls are reading as 1000 which is their minimum. This test procedure verifies the functionality of our RC transmitter and receiver hardware.

7.4.5.2 CPPM Signal Test

Objective: The objective of testing the FlySky receiver CPPM control signals is to verify signal integrity and conformance. This test will utilize the CPPM channel of the FS-iA6B remote control receiver.

Environment: The FlySky RC hardware testing will take place in the environment described in section 7.3. The Analog Discovery 2: 100MS/s USB Oscilloscope, Logic Analyzer and Variable Power Supply by Digilent and QW-MS305D 30V 5A Adjustable DC Stabilizer Power Supply will be utilized in this test procedure.

Procedure: To test the CPPM signal for proper integrity and conformance the procedure is as follows:

- 1) Ensure battery power for the controller is supplied in the form of four AA batteries.
- 2) Connect the power and ground to the RC receiver power supply and set the voltage to 5V.
- 3) If the RC transmitter and receiver are not paired, proceed to pair them. Otherwise, skip this step.
- 4) Connect the CPPM wire to the Naze32 flight controller.
- 5) Open the Cleanflight software and navigate to controller configuration.
- 6) Send a command from the RC transmitter.
- 7) Using the Analog Discovery 2 or another Oscilloscope probe the CPPM output of the RC receiver connected to the Naze32 flight controller.
- 8) Record the captured waveforms.
- 9) Compare the captured results.

Results:

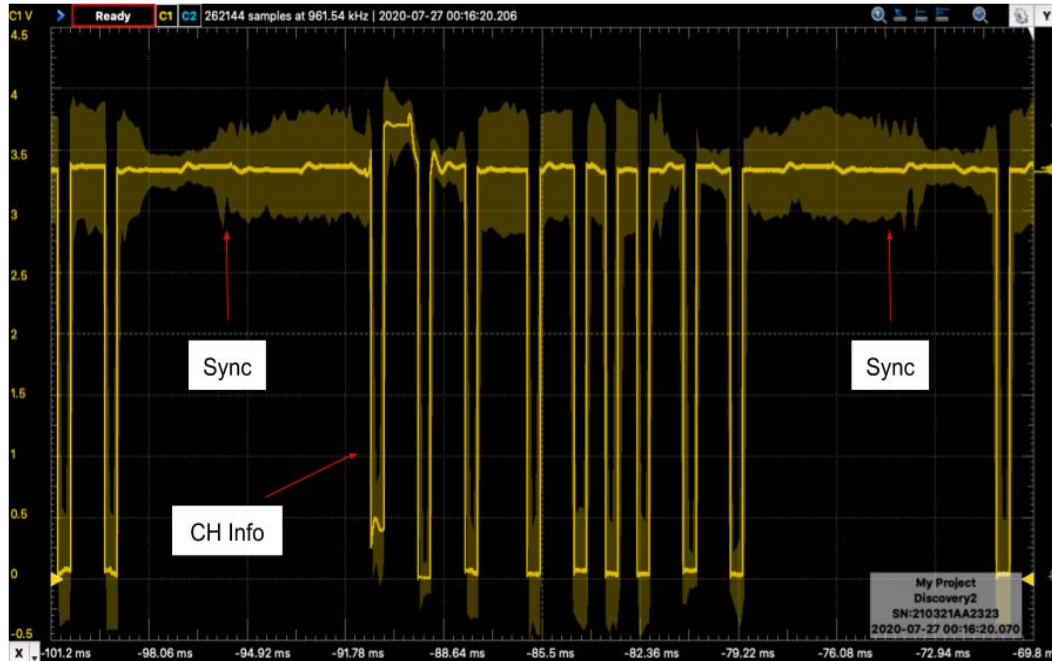

Figure 7.8: CPM Signal Test Result

Conclusion: If during the procedure a clear CPM signal can be captured from the CPM line with well defined regions then the integrity and conformance of the signal to a standard CPM signal can be verified. In our results we can see that when given a command our receiver outputs a CPM signal. The sync regions are well defined at approximately 10ms in width. The channel train or CH Info are also well defined with roughly 1ms per channel. Overall, our FS-iA6B receiver’s CPM output passed.

7.4.6 Video Transmitter and Receiver

7.4.6.1 Video Transmitter Power On Test

Objective: The objective of testing the Eachine TX805 video transmitter is for basic functionality.

Environment: The Eachine TX805 video transmitter hardware testing will take place in the environment described in section 7.3. The Cen-Tech 7 Function Digital Multimeter and QW-MS305D 30V 5A Adjustable DC Stabilizer Power Supply will be utilized in this test procedure.

Procedure: To test the Eachine TX805 for basic functionality the procedure is as follows:

- 1) Start by connecting the TX805 video transmitter to the power supply set at a voltage of 7V.

2) Verify 7V power is good via multimeter and power led indicator.

Results:

Test	Expected (V)	Measured (V)
Power	7.0	6.92

Table 7.5: TX805 Power On Test Results

Conclusion: If during the procedure a stable 7V power line can be verified with a multimeter and the Eachine TX805 video transmitter has power and status indication basic functionality can be verified. As can be seen in results a small amount of voltage sag is witnessed as the load is added, but the TX805 status LEDs were indicating OK. Therefore we can verify basic turn on functionalities for our TX805.

7.5.6.2 Encountered Issues Related to VTX and VRX Testing

We were interested in performing more than just a basic power on test for our video transmitter, but due to the issues discussed in the camera testing section with the Mobius camera intermittently turning off it was not possible. Additionally, as of July 27th, 2020 we have still not received our video receiver. The receiver was ordered on July 10th, 2020 and customer service has been contacted to attempt to expedite this process.

7.5 Software Test Environment

The test environment for the software side of our project can be done anywhere a computer and internet connection are present. The Android IDE will be necessary for its debugger, android API, and emulated android devices. Additionally, a Google Pixel 2 Android Phone will be used as the physical testing device.

Testing Equipment

- A Windows, Mac, or Linux based computer
- Google Pixel 2
- USB Data Cable

Testing Software

- Android IDE
- Java Debugger JDB
- Latest Java Release

7.6 Software Specific Testing

The design and implementation details of our software are found in section 6.0. Unlike the hardware, our software development is not yet underway. Therefore, this section is used to briefly describe the planned testing methods that can be utilized when our software is written.

7.6.1 Software Testing Plan

The software testing plan for future development of the pilot companion app as well as firmware tuning are as follows:

1. Tests will be conducted throughout the development lifecycle and not only at the ending stages for quality assurance.
2. These tests will purposefully be designed for as much use case coverage as possible. This means utilizing edge cases and problematic inputs in addition to known good inputs for testing.
3. Versioning control, such as git will be utilized for code and test code organization.
4. Bug tracking will be used to generate high level visibility of issues and errors.
5. Utilization of logical testing progression procedures, like Unit Testing, Integration Testing, and System Testing.

By providing a set of five important testing pillars the team can have a more standardized approach to software testing. These pillars are concise enough to be easily remembered and referenced. Overall, this is the software testing plan we will adhere to.

8.0 Administrative Content

The following section will be dedicated to the administrative components of the project such as the project milestone and the budget for the project. We will determine our own budget and fund the project ourselves.

8.1 Milestone Discussion

The milestone breakdown of our project will start at the beginning of Senior Design 1 in the summer 2020 semester, with the generation of ideas, to the end of the fall semester of Senior Design 2, with the final presentation of the project.

Senior Design 1		
Description	Duration	Date(s)
Generate Ideas	1.5 weeks	May 14 - May 26
Divide & Conquer 1.0	1 week	May 22 - May 29
D&C Group Meeting	30 min	June 2
Divide & Conquer 2.0	1 week	May 29 - June 5
Finalize group member roles	2 weeks	May 22 - June 5
Begin extensive research based on assigned roles	2 weeks	June 5 - June 19
60 Page Draft Documentation	4 weeks	June 5 - July 3
Choose Components	3 weeks	June 12 - July 3
Begin design for PCB	3 weeks	June 12 - July 3
60 Page Group Meeting	30 min	July 8
100 Page Documentation Updated	2 weeks	July 3 - July 17
Begin ordering parts		TBD
Final Document	1.5 weeks	July 17 - July 28
Senior Design 2		
Description	Duration	Date(s)
Prototype Building	4 weeks	Aug. 24 - Sep. 21
Testing	2 weeks	Sep. 21 - Oct. 5
Final Prototype	2 weeks	Oct. 5 - Oct. 19
Peer Presentation		TBD
Final Report		TBD
Final Presentation		TBD

Table 8.1: Project Milestones

8.2 Budget and Finance Discussion

The following section will showcase each of the selected parts, the quantity of the part needed, where we will acquire the part, and the estimated cost of the part.

Bill of Materials (BOM)			
Item	Price (\$)	Amount	Total (\$)
Mobius Action Camera	83	1	83
Breakout Cable for Mobius	5	1	5
Eachine TX805	39	1	39
Flysky FS-i6X	57	1	57
1/2" PVC Tee	0.46	4	1.84
1/2" x 2' PVC Pipe	1.31	3	3.93
1/4" x 1-1/2" Nylon Hex Bolt	0.96	4	3.84
Nut Nylon 1/4	0.87	4	3.48
4cs EMAX RS2205-S 2300KV	63.99	1	63.99
HQProp Ethix S3 Prop (16 pcs)	17.99	1	17.99
HRB 4S 3300mAh 14.8v Lipo RC Battery	37.99	1	37.99
Naze32 Rev6 Full	19.99	1	19.99
NIDICI BLHeli_32 Bit 35A ESC (4 pack)	50	1	50
Eachine ROTG02 UVC OTG 5.8G 150CH Diversity Audio FPV Receiver	23.99	1	23.99
			411.04

Table 8.2: Project Budget

9.0 Project Summary and Conclusion

Numerous engineering challenges were taken into account while developing and researching the Object Detection Drone. The engineering requirements were determined during the entire process and evolved over time to fit the project more as we gained a better understanding of the project as a whole. Each requirement was designed to take into account every piece of the project that will be used.

The Object Detection Drone is made up of components that might not be much separately, but when combined create an easy to use product that can be used by a wide variety of customers. The ease of use for the product was taken into account during the design phase to improve the useability for the user. One of our goals was to design it in a way that anyone can pick up our product and be able to operate it with little issues along with having easy repair to the product if it is damaged in any way.

The workload was distributed pretty evenly from electrical engineering and computer engineering to provide a suitable product that can showcase all of our strengths and improve our understanding of concepts that we might have been weaker on. The design of our physical parts and the software would allow the team to contribute effectively using our strengths, interests, and our input.

Appendix A - Copyright Permissions

Permission to Use Picture

sSasquatch, horaceCJ · Yesterday at 10:59 PM

Edit Star Mark unread Leave

Yesterday at 10:59 PM

Good afternoon,

I am a Computer Engineering student enrolled in senior design at the University of Central Florida. I am writing to request your permission to reference figures/images from your picture in the thread "Sd Card won't lock in" in a design paper that will not be published, with proper attribution to you.

Thank you very much,

Tony

Report

+Quote Reply

sSasquatch
New Member
Joined: Jul 27, 2020
Messages: 0
Reaction score: 0
Location: ga
Country: United States

1 minute ago

Hello,

Of course you can use it, no problem at all.

Report

+Like +Quote Reply

horaceCJ
Active Member
Joined: Mar 15, 2013
Messages: 197
Reaction score: 210
Country: Romania
Dash Cam: Mobius A/B/C / 808 #16D



Tue 7/28/2020 5:21 AM

Marcin Dryjanski <marcin.dryjanski@grandmetric.com>

RE: Permission to Use Figures

To: Anthony Pionessa

Cc: info

Dear Anthony!

Thanks for your email and request. We hereby agree that you can use our figures from that section if our web is quoted. Are you going to use all of the figures from that section or a subset?

Best regards,

Marcin Dryjanski, Ph.D.

Technical Advisor // Distinguished Engineer



+48 515 260 400

marcin.dryjanski@grandmetric.com

ul. Metalowa 5
60-118 Poznan, Poland

www.grandmetric.com

www.grandmetric.com/blog

From: Anthony Pionessa <apionessa8@Knights.ucf.edu>

Sent: Tuesday, July 28, 2020 4:44 AM

To: info <info@grandmetric.com>

Subject: Permission to Use Figures

Good afternoon,

I am a Computer Engineering student enrolled in senior design at the University of Central Florida. I am writing to request your permission to reference figures/images from the section "12. Interference & Noise" on your website in a design paper that will not be published, with proper attribution to you/your website.

Thank you very much,

Anthony Pionessa

apionessa8@knights.ucf.edu



Mon 7/27/2020 10:46 PM

Anthony Pionessa

Permission to Use Figures

To support@arcdyn.com

Good afternoon,

I am a Computer Engineering student enrolled in senior design at the University of Central Florida. I am writing to request your permission to reference figures/images from the article "What does 1000TVL mean? Avoiding Misleading Resolutions" on your website in a design paper that will not be published, with proper attribution to you/your website.

Thank you very much,

Anthony Pionessa
apionessa8@knights.ucf.edu



Mon 7/27/2020 10:48 PM

Anthony Pionessa

Permission to Use Figure

To oscarliang@outlook.com

Good afternoon,

I am a Computer Engineering student enrolled in senior design at the University of Central Florida. I am writing to request your permission to reference figures/images from the article "How to Choose FPV Camera for Quadcopters and Drones" on your website in a design paper that will not be published, with proper attribution to you/your website.

Thank you very much,

Anthony Pionessa
apionessa8@knights.ucf.edu



Mon 7/27/2020 10:57 PM

Anthony Pionessa

Permission to Use Figures

To techplayon@gmail.com

Good afternoon,

I am a Computer Engineering student enrolled in senior design at the University of Central Florida. I am writing to request your permission to reference figures/images from the article "Drone Wireless Video Transmission – Technologies, Challenges and Probable Solutions!" on your website in a design paper that will not be published, with proper attribution to you/your website.

Thank you very much,

Anthony Pionessa

apionessa8@knights.ucf.edu

Tony

Captcha:

11 + 8 = 19

apionessa8@knights.ucf.edu

Permission to Use Images

Good afternoon,

I am a Computer Engineering student enrolled in senior design at the University of Central Florida. I am writing to request your permission to reference figures/images from listings on your website (such as "Mobius Video/Audio-Out Cable") in a design paper that will not be published, with proper attribution to your website.

Thank you very much,

Anthony Pionessa

apionessa8@knights.ucf.edu

SUBMIT

RESET



Mon 7/27/2020 11:10 PM

Anthony Pionessa

Permission to Use Images

To amazon-pr@amazon.com

Good afternoon,

I am a Computer Engineering student enrolled in senior design at the University of Central Florida. I am writing to request your permission to reference figures/images from listings on your website (such as "JMT 3D TPU Camera Mount Action Camera Protector Holder for iFlight MegaBee FPV Racing Drone (Red)") in a design paper that will not be published, with proper attribution to your website.

Thank you very much,

Anthony Pionessa

apionessa8@knights.ucf.edu



Mon 7/27/2020 11:14 PM

Anthony Pionessa

Permission to Use Images

To lawservice@banggood.com

Good afternoon,

I am a Computer Engineering student enrolled in senior design at the University of Central Florida. I am writing to request your permission to reference figures/images from listings on your website (such as "Caddx Firefly 1/3" CMOS 1200TVL 2.1mm Lens 16:9 / 4:3 NTSC/PAL FPV Camera With VTX For RC Drone - PAL 4:3in a design paper that will not be published, with proper attribution to your website.

Thank you very much,

Anthony Pionessa

apionessa8@knights.ucf.edu



Tue 7/28/2020 9:09 AM

GetFPV Support <support@getfpv.com>

Re: Permission to Use Pictures

To: Anthony Pionessa

If there are problems with how this message is displayed, click here to view it in a web browser.
Click here to download pictures. To help protect your privacy, Outlook prevented automatic download of some pictures in this message.

Blake replied

Jul 28, 9:08

Hello again,

That won't be a problem at all so long as the material is properly cited. We wish you the best of luck with your paper!

Best Regards,
Blake

—
Blake Miller
Customer Service Representative
support@getfpv.com
GetFPV / <http://www.getfpv.com> - the online retailer and distributor of the finest FPV products.

How would you rate my reply?

Blake replied

Jul 28, 6:44

Hello Anthony,

Possibly - I've reached out to management to check, and will be back in touch ASAP either way.

Best Regards,
Blake

—
Blake Miller
Customer Service Representative
support@getfpv.com
GetFPV / <http://www.getfpv.com> - the online retailer and distributor of the finest FPV products.

Anthony Pionessa sent a message

Jul 27, 2:16

Good afternoon,

I am a Computer Engineering student enrolled in senior design at the University of Central Florida. I am writing to request your permission to reference figures/images from listings on your website (such as "TBS Unity Pro 5G8 HV - Race 2 (MMCX)") in a design paper that will not be published, with proper attribution to your website.

Thank you very much,

Anthony Pionessa
apionessa8@knights.ucf.edu



Tue 7/28/2020 8:23 AM

Ben Harris <ben@harrisaerial.com>

Re: Permission to Use Image

To Anthony Pionessa

Cc info@harrisaerial.com

Sure

On Mon, Jul 27, 2020 at 11:17 PM Anthony Pionessa <apionessa8@knights.ucf.edu> wrote:

Good afternoon,

I am a Computer Engineering student enrolled in senior design at the University of Central Florida. I am writing to request your permission to reference figures/images from listings on your website (such as "Mobius ActionCam Wide Angle 1080P 30FPS") in a design paper that will not be published, with proper attribution to your website.

Thank you very much,

Anthony Pionessa

apionessa8@knights.ucf.edu

--

Benjamin Harris
President - Harris Aerial
850-380-4748





Tue 7/28/2020 6:06 AM

Dejan Nedelkovski <dejan_nedelkovski@hotmail.com>

Re: Permission to Use Image

To Anthony Pionessa

 Click here to download pictures. To help protect your privacy, Outlook prevented automatic download of some pictures in this message.

Hey,

Thanks for contacting me. Sure, as long as you give proper attribution you can use the images.

Cheers,
Dejan

From: Anthony Pionessa <apionessa8@Knights.ucf.edu>

Sent: Tuesday, July 28, 2020 5:39 AM

To: dejan_nedelkovski@hotmail.com <dejan_nedelkovski@hotmail.com>

Subject: Permission to Use Image

Good afternoon,

I am a Computer Engineering student enrolled in senior design at the University of Central Florida. I am writing to request your permission to reference figures/images from the article "How Brushless Motor and ESC Work" on your website in a design paper that will not be published, with proper attribution to you/your website.

Thank you very much,

Anthony Pionessa
apionessa8@knights.ucf.edu



Tue 7/28/2020 8:49 AM

Terry O'Grady <togrady@e-jpc.com>

RE: Permission to Use Image

To: Anthony Pionessa

Action Items

+ Get more ad

Hello Anthony,

That is no problem – best of luck.

Terry O'Grady
Manager Inside Sales

Note that we now have an e-mail address for purchase orders only.
Please send all purchase orders to purchaseorders@e-jpc.com



JPC (Japanese Products Corporation) Division of Elinco is North America distribution of Nidec Servo Motors and fans
1525 Kings Highway East, Fairfield, CT 06824
Ph: 203-334-7537 Ext. 104 Fx: 203-334-7792
WEBSITE www.E-JPC.com
QMS ISO 9001:2015 CERTIFIED

From: Anthony Pionessa <apionessa8@knights.ucf.edu>
Sent: Monday, July 27, 2020 11:42 PM
To: Terry O'Grady <togrady@e-jpc.com>
Subject: Permission to Use Image

Good afternoon,

I am a Computer Engineering student enrolled in senior design at the University of Central Florida. I am writing to request your permission to reference figures/images from the article "Construction Difference of Brushless vs Brushed Motor" on your website in a design paper that will not be published, with proper attribution to you/your website.

Thank you very much,

Anthony Pionessa
apionessa8@knights.ucf.edu

Email:

apionessa8@knights.ucf.edu

Content:

Good afternoon,
I am a Computer Engineering student enrolled in senior design at the University of Central Florida. I am writing to request your permission to reference figures/images from listings on your website (such as "[Eachine TX805 5.8G 40CH 25/200/600/800mW FPV Transmitter TX LED Display Support OSD/Pitmode/Smart Audio - RP-SMA Female](#)") in a design paper

that will not be published, with proper attribution to your website.
Thank you very much,
Anthony Pionessa
apionessa8@knights.ucf.edu

Contact

Your Name (required)

Kristian Aspi

Your Email (required)

kristian.aspi@knights.ucf.edu

Subject

Permission to Use Image

Your Message

Hello,

I am a Computer Engineering student enrolled in Senior Design at the University of Central Florida. I am writing to request your permission to reference figures/images from listings on your website (<https://dronenodes.com/drone-frame-racing-freestyle/>) in a design paper that will not be published, with proper attribution to your website.



To

support@ravpower.com

Cc

Subject Permission to Use Image

Hello,

I am a Computer Engineering student enrolled in Senior Design at the University of Central Florida. I am writing to request your permission to reference figures/images from listings on your website (<https://blog.ravpower.com/2017/06/lithium-ion-vs-lithium-polymer-batteries/>) in a design paper that will not be published, with proper attribution to your website.

Thank you,
Kristian Aspi

Appendix B - References

- [1] "12. Interference & Noise - Grandmetric," Grandmetric.com. [Online]. Available: <http://www.grandmetric.com/topic/12-interference-noise/>. [Accessed: 27-Jul-2020].
- [2] admin, "Different types of wireless communication technologies," Typesnuses.com, 09-Dec-2019. [Online]. Available: <http://www.typesnuses.com/different-types-wireless-communication-technologies/>. [Accessed: 27-Jul-2020].
- [3] admin, "Drone wireless video transmission - technologies, challenges and probable solutions ! - techplayon," Techplayon.com, 15-Dec-2017. [Online]. Available: <http://www.techplayon.com/drone-wireless-video-transmission-technologies-challenges-probable-solutions/>. [Accessed: 27-Jul-2020].
- [4] Amazon.com. [Online]. Available: https://www.amazon.com/AKASO-EK7000-Sports-Waterproof-Camcorder/dp/B01LMVIS18/ref=sr_1_14?dchild=1&keywords=dbpower%2Baction%2Bcamera&qid=1593318556&sr=8-14&th=1. [Accessed: 27-Jul-2020].
- [5] Amazon.com. [Online]. Available: https://www.amazon.com/BETAFPV-Transmitter-SmartAudio-Beta65S-Pin-Connected/dp/B07X96YBJT/ref=sr_1_4?camp=1789&creative=9325&dchild=1&keywords=BetaFPV+Z02+camera&linkCode=xm2&linkId=693f79b3e4ba39666428da875124f383&qid=1593479929&sr=8-4&tag=oscar0f7-20. [Accessed: 27-Jul-2020].
- [6] Amazon.com. [Online]. Available: <https://www.amazon.com/Black-Box-Mobius-Action-Camera/dp/B00N6AWQ5I>. [Accessed: 27-Jul-2020].
- [7] Amazon.com. [Online]. Available: <https://www.amazon.com/Flysky-FS-i6X-Transmitter-FS-iA6B-Receiver/dp/B0744DPPL8>. [Accessed: 27-Jul-2020].
- [8] Amazon.com. [Online]. Available: <https://www.amazon.com/FrSky-Taranis-Channels-Transmitter-Controller/dp/B06XQWQ7C3>. [Accessed: 27-Jul-2020].
- [9] Amazon.com. [Online]. Available: https://www.amazon.com/GOQOTOMO-Wireless-Transmitter-Receiver-Vehicle/dp/B07T8HMCMN/ref=sr_1_15?dchild=1&keywords=video+transmitter&qid=1593228178&sr=8-15. [Accessed: 27-Jul-2020].

- [10] Amazon.com. [Online]. Available: <https://www.amazon.com/JMT-Printed-Protector-iFlight-MegaBee/dp/B083TXRWMZ>. [Accessed: 27-Jul-2020].
- [11] Amazon.com. [Online]. Available: <https://www.amazon.com/Turnigy-Evolution-Digital-TGY-iA6C-Receiver/dp/B07TD7VM6P>. [Accessed: 27-Jul-2020].
- [12] Banggood.com, "Caddx firefly 1/3" CMOS 1200TVL 2.1mm lens 16:9 / 4:3 NTSC/PAL FPV camera with VTX for RC drone RC parts from toys hobbies and robot on banggood.Com," Banggood.com. [Online]. Available: http://www.banggood.com/Caddx-Firefly-13-CMOS-1200TVL-2_1mm-Lens-169-43-NTSCPAL-FPV-Camera-With-VTX-For-RC-Drone-p-1339731.html?p=OY2106728901201408U4. [Accessed: 27-Jul-2020].
- [13] Banggood.com, "Eachine ROTG01 UVC OTG 5.8G 150CH full channel FPV receiver for android mobile phone tablet smartphone RC parts from toys hobbies and robot on banggood.Com," Banggood.com. [Online]. Available: http://usa.banggood.com/Eachine-ROTG01-UVC-OTG-5_8G-150CH-Full-Channel-FPV-Receiver-For-Android-Mobile-Phone-Smartphone-p-1147692.html?ID=224. [Accessed: 27-Jul-2020].
- [14] Banggood.com, "Eachine ROTG02 UVC OTG 5.8G 150CH Diversity Audio FPV Receiver for Android Tablet Smartphone RC Parts from Toys Hobbies and Robot on banggood.com," Banggood.com. [Online]. Available: http://www.banggood.com/Eachine-ROTG02-UVC-OTG-5_8G-150CH-Dual-Antenna-Audio-FPV-Receiver-for-Android-Tablet-Smartphone-p-1242422.html?rmmds=search. [Accessed: 27-Jul-2020].
- [15] Banggood.com, "Eachine TX805 5.8G 40CH 25/200/600/800mW FPV Transmitter TX LED Display Support OSD/Pitmode/Smart Audio RC Parts from Toys Hobbies and Robot on banggood.com," Banggood.com. [Online]. Available: http://www.banggood.com/Eachine-TX805-5_8G-40CH-25-or-200-or-600-or-800mW-FPV-Transmitter-TX-LED-Display-Support-OSD-or-Pitmode-or-Smart-Audio-p-1333984.html?akmClientCountry=America. [Accessed: 27-Jul-2020].
- [16] Banggood.com, "FrSky Taranis X-lite ACCST 2.4GHz 16CH Mode2 radio transmitter with 18650 battery black caps for RC drone FPV racing muliti rotor RC parts from toys hobbies and robot on banggood.Com," Banggood.com. [Online]. Available: http://www.banggood.com/FrSky-Taranis-X-Lite-ACCST-2_4GHz-16CH-M

ode2-Radio-Transmitter-with-18650-Battery-Black-Caps-for-RC-Drone-FPV-Racing-Muliti-Rotor-p-1257443.html?ID=224. [Accessed: 27-Jul-2020].

- [17] Banggood.com, "RC832HD 5.8GHz 48CH high sensitivity 1080P HDMI AV FPV receiver with SMA antenna for RC drone RC parts from toys hobbies and robot on banggood.Com," Banggood.com. [Online]. Available:
http://www.banggood.com/RC832HD-5_8GHz-48CH-High-Sensitivity-1080P-HDMI-AV-FPV-Receiver-With-SMA-Antenna-For-RC-Drone-p-1535558.html?rmmms=search. [Accessed: 27-Jul-2020].
- [18] Banggood.com, "Realacc X-lite transmitter edition FPV RC drone shoulder bag handbag for FrSky X-lite/ X-lite S/ X-lite pro RC parts from toys hobbies and robot on banggood.Com," Banggood.com. [Online]. Available:
<http://www.banggood.com/Realacc-X-lite-Transmitter-Edition-FPV-RC-Drone-Shoulder-Bag-Handbag-for-FrSky-X-lite-X-lite-S-X-lite-Pro-p-1331474.html?akmClientCountry=America>. [Accessed: 27-Jul-2020].
- [19] B. Dofflemyer, "What does 1000TVL mean? Avoiding Misleading Resolutions - Arcdyn Articles," Arcdyn.com, 02-Jan-2017. [Online]. Available: <http://www.arcdyn.com/articles/what-does-1000tvl-mean/>. [Accessed: 27-Jul-2020].
- [20] DronesGator, "Taranix x lite review vs Taranis qx7 - Range test at the end," 07-Sep-2018. [Online]. Available:
<https://www.youtube.com/watch?v=EF-UjLTQ4QY>. [Accessed: 27-Jul-2020].
- [21] Author: Technical Editor, "Advantages and disadvantages of Bluetooth - polytechnic hub," Polytechnichub.com, 29-Apr-2017. [Online]. Available:
<http://www.polytechnichub.com/advantages-disadvantages-bluetooth/>. [Accessed: 27-Jul-2020].
- [22] Techwalla.com. [Online]. Available:
<http://www.techwalla.com/articles/the-effective-range-of-bluetooth>. [Accessed: 27-Jul-2020].
- [23] D. Falkjar, =SUBROSA=, ksa_maxx, Unknown, and M. L. Massar, "RunCam Phoenix 2," Runcam.com. [Online]. Available:
<http://shop.runcam.com/runcam-phoenix-2/>. [Accessed: 27-Jul-2020].
- [24] K. Fessel, "5 significant object detection challenges and solutions," Towards Data Science, 21-Sep-2019. [Online]. Available:

- <http://towardsdatascience.com/5-significant-object-detection-challenges-and-solutions-924cb09de9dd>. [Accessed: 27-Jul-2020].
- [25] J. Goldman, "Stripped-down GoPro Hero still pumps out good video," CNET, 11-Nov-2014. [Online]. Available: <http://www.cnet.com/products/gopro-hero/specs/>. [Accessed: 27-Jul-2020].
- [26] T. V. W. & G. G. Karim Nice, "How Digital Cameras Work," Howstuffworks.com, 29-Nov-2006. [Online]. Available: <http://electronics.howstuffworks.com/cameras-photography/digital/digital-camera3.htm>. [Accessed: 27-Jul-2020].
- [27] V. LaManna, "Mobius Basic ActionCam," Mobius-actioncam.com. [Online]. Available: <http://www.mobius-actioncam.com/store/products/mobius-basic-actioncam-3/>. [Accessed: 27-Jul-2020].
- [28] Mario, "Can drones fly without Wi-Fi? | Tips For Drones," Tipsfordrones.com, 03-Jan-2019. [Online]. Available: <http://tipsfordrones.com/can-drones-fly-without-wi-fi/>. [Accessed: 27-Jul-2020].
- [29] Matt Gholson, "Flysky FS-i6X Range Test FPV Inside Car," 08-Dec-2018. [Online]. Available: https://www.youtube.com/watch?v=Zwaww_n61k4. [Accessed: 27-Jul-2020].
- [30] Oliver, "Best RC transmitter for FPV quadcopters (2020 updated)," Fpvfrenzy.com, 02-Jan-2020. .
- [31] Oscar, "How to choose FPV camera for quadcopters and drones - Oscar Liang," Oscarliang.com, 18-Oct-2019. [Online]. Available: <http://oscarliang.com/best-fpv-camera-quadcopter/>. [Accessed: 27-Jul-2020].
- [32] "Reviews Cameras, Lenses and accessories | JuzaPhoto," Juzaphoto.com. [Online]. Available: <http://www.juzaphoto.com/recensione.php?l=en>. [Accessed: 27-Jul-2020].
- [33] 911 security, "Drone Communication - Data Link," 911Security.com. [Online]. Available: <http://www.911security.com/learn/airspace-security/drone-fundamentals/drone-communication-data-link>. [Accessed: 27-Jul-2020].
- [34] "Skydroid 5.8GHz OTG Dual Antenna FPV Receiver for Android Smartphone," Getfpv.com. [Online]. Available:

- <http://www.getfpv.com/skydroid-5-8ghz-otg-dual-antenna-fpv-receiver-for-android-smartphone.html>. [Accessed: 27-Jul-2020].
- [35] Sleepwalker FPV, "Turnigy Evolution range test 1.7 Km," 16-Oct-2017. [Online]. Available: <https://www.youtube.com/watch?v=LMZoQwq43p0>. [Accessed: 27-Jul-2020].
- [36] "TBS Unify Pro 5G8 HV - Race 2 (MMCX)," Getfpv.com. [Online]. Available: <http://www.getfpv.com/tbs-unify-pro-5g8-hv-race-2-mmcx.html>. [Accessed: 27-Jul-2020].
- [37] "TBS Unify Pro32 HV 5.8GHz Video Transmitter (MMCX)," Getfpv.com. [Online]. Available: <http://www.getfpv.com/tbs-unify-pro32-5-8ghz-video-transmitter.html>. [Accessed: 27-Jul-2020].
- [38] "Turnigy 9X 9Ch Mode 2 Transmitter w/ Module & iA8 Receiver (AFHDS 2A system)," Hobbyking.com. [Online]. Available: http://hobbyking.com/en_us/turnigy-9x-9ch-mode-2-transmitter-w-module-i-a8-receiver-afhds-2a-system.html. [Accessed: 27-Jul-2020].
- [39] Wikipedia contributors, "List of WLAN channels," Wikipedia, The Free Encyclopedia, 26-Jul-2020. [Online]. Available: https://en.wikipedia.org/w/index.php?title=List_of_WLAN_channels&oldid=969608246. [Accessed: 28-Jul-2020].
- [40] Wikipedia contributors, "IEEE 802.11," Wikipedia, The Free Encyclopedia, 25-Jul-2020. [Online]. Available: https://en.wikipedia.org/w/index.php?title=IEEE_802.11&oldid=969403993. [Accessed: 28-Jul-2020].
- [41] Wikipedia contributors, "IEEE 802.11ac," Wikipedia, The Free Encyclopedia, 18-May-2020. [Online]. Available: https://en.wikipedia.org/w/index.php?title=IEEE_802.11ac&oldid=957409110. [Accessed: 28-Jul-2020].
- [42] Amazon.com. [Online]. Available: <https://www.amazon.com/GoPro-CHDHA-301-HERO/dp/B00NIYNUXO?th=1>. [Accessed: 28-Jul-2020].
- [43] *Amazon.com*. [Online]. Available: <https://www.amazon.com/EMAX-RS2205-S-Brushless-Multicopter/dp/B07B498BTB>. [Accessed: 27-Jul-2020].

- [44] *Amazon.com*. [Online]. Available: <https://www.amazon.com/iFlight-2450KV-Brushless-Racing-Quadcopter/dp/B07TL6R8GK>. [Accessed: 27-Jul-2020].
- [45] *Amazon.com*. [Online]. Available: <https://www.amazon.com/Racerstar-BR2207S-1600KV-Brushless-200-300mm/dp/B07PDD6JNC>. [Accessed: 27-Jul-2020]
- [46] “MQTB - Motor Data: Emax RS2205S 2300kv Retest,” *Miniquadtestbench.com*. [Online]. Available: <https://www.miniquadtestbench.com/assets/components/motordata/motorinfo.php?uid=144>. [Accessed: 27-Jul-2020].
- [47] “MQTB - iFlight Xing 2306 2450kv,” *Miniquadtestbench.com*. [Online]. Available: <https://www.miniquadtestbench.com/iflight-xing-2306-2450kv.html>. [Accessed: 27-Jul-2020].
- [48] “thrust results table BrotherHobby RACERSTAR BR2207-1600KV.xlsx,” *Dropbox.com*. [Online]. Available: <https://www.dropbox.com/s/5vbxz983n757w5q/thrust%20results%20table%20BrotherHobby%20RACERSTAR%20BR2207-1600KV.xlsx?dl=0>. [Accessed: 28-Jul-2020].
- [49] V. LaManna, “Mobius Video/Audio-Out Cable,” *Mobius-actioncam.com*. [Online]. Available: <https://www.mobius-actioncam.com/store/products/videoaudio-out-cable/>. [Accessed: 28-Jul-2020].
- [50] *Amazon.com*. [Online]. Available: https://www.amazon.com/RunCam-Phoenix-Camera-1000TVL-Freestyle/dp/B084FSDY5D/ref=sr_1_2?camp=1789&creative=9325&dchild=1&keywords=micro+eagle+fpv+camera&linkCode=xm2&linkId=a837fa39cece64e3dbfb39cd46197d46&qid=1593292245&sr=8-2&tag=oscar0f7-20. [Accessed: 28-Jul-2020].
- [51] “What is the Screen Resolution or the Aspect Ratio? What do 720p, 1080i & 1080p Mean?,” *Comtech-networking.com*. [Online]. Available: <https://www.comtech-networking.com/blog/item/4-what-is-the-screen-resolution-or-the-aspect-ratio-what-do-720p-1080i-1080p-mean/>. [Accessed: 28-Jul-2020].
- [52] “File:Quadcopter camera drone in flight.jpg - Wikimedia Commons,” *Wikimedia.org*. [Online]. Available:

- https://commons.wikimedia.org/wiki/File:Quadcopter_camera_drone_in_flight.jpg. [Accessed: 28-Jul-2020].
- [53] “Model IMU, GPS, and INS/GPS - MATLAB & Simulink,” *Mathworks.com*. [Online]. Available: <https://www.mathworks.com/help/fusion/gs/model-imu-gps-and-insgps.html>. [Accessed: 28-Jul-2020].
- [54] “File:Wind drift.png - Wikimedia Commons,” *Wikimedia.org*. [Online]. Available: https://commons.wikimedia.org/wiki/File:Wind_drift.png. [Accessed: 28-Jul-2020].
- [55] Oscar, “F1, F3, F4, F7 and H7 Flight Controller Explained - Oscar Liang,” *Oscarliang.com*, 22-May-2019. [Online]. Available: <https://oscarliang.com/f1-f3-f4-flight-controller/>. [Accessed: 28-Jul-2020].
- [56] “File:UAV Flight control.jpg - Wikimedia Commons,” *Wikimedia.org*. [Online]. Available: https://commons.wikimedia.org/wiki/File:UAV_Flight_control.jpg. [Accessed: 28-Jul-2020].
- [57] “TBS Unify Pro32 HV 5.8GHz Video Transmitter (MMCX),” *Getfpv.com*. [Online]. Available: <https://www.getfpv.com/tbs-unify-pro32-5-8ghz-video-transmitter.html>. [Accessed: 28-Jul-2020].
- [58] R. 2019-11-, “High quality, license-free, ultra-tiny vtx,” *Team-blacksheep.com*. [Online]. Available: <https://www.team-blacksheep.com/tbs-unify-pro32-manual.pdf>. [Accessed: 28-Jul-2020].
- [59] “TBS Unify Pro 5G8 HV - Race 2 (MMCX),” *Getfpv.com*. [Online]. Available: <https://www.getfpv.com/tbs-unify-pro-5g8-hv-race-2-mmcx.html>. [Accessed: 28-Jul-2020].
- [60] “How Brushless Motor and ESC Work - HowToMechatronics,” *Howtomechatronics.com*, 04-Feb-2019. [Online]. Available: <https://howtomechatronics.com/how-it-works/how-brushless-motor-and-esc-work/>. [Accessed: 28-Jul-2020].
- [61] *Banggood.com*. [Online]. Available: <http://img.banggood.com/file/products/20180724023109FireFlyVTXCameraManual.pdf>. [Accessed: 28-Jul-2020].
- [62] “Turnigy 9X 9Ch Mode 2 Transmitter w/ Module & iA8 Receiver (AFHDS 2A system),” *Hobbyking.com*. [Online]. Available:

- https://hobbyking.com/en_us/turnigy-9x-9ch-mode-2-transmitter-w-module-ia8-receiver-afhds-2a-system.html. [Accessed: 28-Jul-2020].
- [63] DN, “How to choose drone frame for racing or freestyle? - Drone Nodes.”
- [64] B. GetFPV, “All about Multirotor FPV Drone Propellers | GetFPV Learn,” *Getfpv.com*, 03-Feb-2018. [Online]. Available: <https://www.getfpv.com/learn/new-to-fpv/all-about-multirotor-fpv-drone-propellers/>. [Accessed: 28-Jul-2020].
- [65] Oscar, “FPV Drone ESC Buyer’s Guide - Oscar Liang,” *Oscarliang.com*, 01-Feb-2020. [Online]. Available: <https://oscarliang.com/choose-esc-racing-drones/>. [Accessed: 28-Jul-2020].
- [66] Team RAVPower, “Lithium ion vs. Lithium polymer batteries – which is better? - RAVPower,” *Ravpower.com*, 20-Jun-2017. [Online]. Available: <https://blog.ravpower.com/2017/06/lithium-ion-vs-lithium-polymer-batteries/>. [Accessed: 28-Jul-2020].
- [67] PLA vs ABS – filaments for 3D printing compared. (2019, March 19). Retrieved July 28, 2020, from All3dp.com website: <https://all3dp.com/1/pla-vs-abs-filament-3d-printing/>
- [68] DN. (n.d.). *Power Distribution Board PDB - drone nodes*. Retrieved from <https://dronenodes.com/pdb-power-distribution-board/>
- [69] PID tuning - cleanflight. (n.d.). Retrieved from Readthedocs.io website: <https://cleanflight.readthedocs.io/en/latest/PID%20tuning/>
- [70] Z. Zhou, Z. Shi, Y. Guo, et al. 2019, Object Detection in 20 Years: A Survey, arXiv:1905.05055 [cs.CV], (May, 2019). This work has been submitted to the IEEE TPAMI for possible publication.
- [71] W. Liu, D. Anguelov, D. Erhan, C. Szegedy, S. Reed, C.-Y. Fu, and A. C. Berg, “Ssd: Single shot multibox detector,” in European conference on computer vision. Springer, 2016, pp. 21–37
- [72] J. Redmon, S. Divvala, R. Girshick, and A. Farhadi, “You only look once: Unified, real-time object detection,” in Proceedings of the IEEE conference on computer vision and pattern recognition, 2016, pp. 779–788.
- [73] R. Girshick, “Fast r-cnn,” in Proceedings of the IEEE international conference on computer vision, 2015, pp. 1440–1448.

- [74] S. Ren, K. He, R. Girshick, and J. Sun, "Faster r-cnn: Towards real-time object detection with region proposal networks," in Advances in neural information processing systems, 2015, pp. 91–99.
- [75] R. Girshick, J. Donahue, T. Darrell, and J. Malik, "Rich feature hierarchies for accurate object detection and semantic segmentation," in Proceedings of the IEEE conference on computer vision and pattern recognition, 2014, pp. 580– 587.
- [76] Object detection and image classification with YOLO - KDnuggets. (n.d.), Retrieved from Kdnuggets.com website:
<https://www.kdnuggets.com/2018/09/object-detection-image-classification-yolo.html>
- [77] Feature extraction using convolution - Ufldl. (n.d.). Retrieved from Stanford.edu website:
http://deeplearning.stanford.edu/wiki/index.php/Feature_extraction_using_convolution

