

University of Central Florida



Department of Electrical & Computer Engineering

2

**H.E.A.T.**  
Heat Emitting Automatic Temperature  
**SQUARE**

Senior Design 1 Paper

Senior Design 1 - EEL 4914 - Summer 2020

7/27/2020

Group 8

David Berlino - EE  
Arjune Toolsie - EE  
Devin Singh - CE  
Bobby Federici - EE

# Table of Contents

List of Figures.....	5
<b>1. Executive Summary.....</b>	<b>7</b>
<b>2. Project Description.....</b>	<b>8</b>
2.1. Motivation.....	8
2.2. Objectives and Goals.....	9
2.3. Requirements and Specifications.....	9
2.4. Standards.....	13
2.4.1. Electromagnetic Interference (EMI) Standards.....	13
2.4.1.1. Federal Communications Commission.....	14
2.4.1.2. ANSI C63.4.....	14
2.4.1.3. IEC EN61000.....	14
2.4.2. Sensor Standards.....	15
2.4.2.1. IEC Standards.....	15
2.4.3. Printed Circuit Board Standards .....	15
2.4.3.1. IPC-2152.....	15
2.4.3.2. Soldering Standards.....	16
2.4.3.3. IPC J-STD-001 & IPC-A-610.....	16
2.4.3.4. NASA-STD-8739.3.....	17
2.4.4. Insulated Conductors Standards.....	17
2.4.4.1. Receptacle & Connector Standards.....	20
2.4.5. Power Switchgear, Circuits, and Fuses.....	20
2.4.6. Power Systems Communications Standards.....	21
2.4.7. Surge Protection Device Standards.....	23
2.4.8. Power Testing, Instrumentation, and Measurements Standards.....	24
2.4.9. LED Light Flickering and Potential Health Concerns.....	26
2.4.10. Minimum Lighting Standard.....	28
2.4.11. Safety Standards for LED Products.....	28
2.4.12. ANSI Common Terminology.....	29
2.4.13. Bluetooth Standards.....	30
2.4.14. Wi-Fi Standards.....	30
2.4.15. RFID Standards.....	30
2.5. Constraints.....	31
2.5.1. Economic Constraints.....	31
2.5.2. Environmental Constraints.....	31
2.5.3. Safety Constraints.....	32
2.5.4. Ethical Constraints.....	32
2.5.5. Political Constraints.....	33
2.5.6. Cultural Constraints.....	33
2.6. Block Diagram.....	33
2.6.1. Hardware.....	34
2.6.2. Software.....	35
2.7. House of Quality.....	35
<b>3. Research.....</b>	<b>37</b>

3.1.	Microcontroller.....	37
3.2.	Communication Considerations.....	38
3.2.1.	RFID.....	38
3.2.2.	Bluetooth.....	40
3.2.3.	Wi-Fi.....	41
3.2.4.	Microcontroller Communication Conclusions.....	42
3.3.	Application Considerations.....	42
3.3.1.	No Application.....	42
3.3.2.	Web Application.....	43
3.3.3.	Mobile Application.....	44
3.3.4.	Application Conclusions.....	45
3.4.	Power Considerations.....	45
3.4.1.	Solar Power.....	45
3.4.1.1	Solar Panel.....	46
3.4.1.2	Photovoltaic (Solar PV) Panels.....	47
3.4.1.3	Solar Thermal Panels.....	47
3.4.2.	Battery Power.....	48
3.4.2.1.	Capacity and Power.....	49
3.4.2.2.	Depth of Discharge (DoD).....	49
3.4.2.3.	Round-Trip Efficiency.....	50
3.4.2.4.	Battery Life, Warranty & Manufacturers.....	50
3.4.3.	Battery Types.....	52
3.4.3.1.	Lead-Acid Batteries.....	52
3.4.3.2.	Lithium Ion Batteries.....	52
3.4.3.3.	Nickel Cadmium (NiCd).....	53
3.4.3.4.	Nickel Metal Hydride (NiMH).....	53
3.4.3.5.	Reusable Alkaline Battery.....	53
3.4.4.	Power Outlet.....	54
3.4.5.	Heating System Power.....	56
3.4.5.1.	Heating System Power Pros.....	57
3.4.5.2.	Heating System Power Cons.....	58
3.5.	Sensors.....	59
3.5.1.	Resistance Temperature Detector (RTD) Sensors.....	59
3.5.2.	Thermistors.....	61
3.5.3.	Thermocouples.....	62
3.5.4.	Side by Side Comparison of Temperature Sensors.....	64
3.5.5.	Thermal Humidity Sensors.....	64
3.5.6.	Capacitive Humidity Sensors.....	65
3.5.7.	Resistive Humidity Sensors.....	66
3.5.8.	Side by Side Comparison of Humidity Sensors.....	66
3.6.	Heating System.....	67
3.6.1.	Electric Heating System.....	67
3.6.2.	Hydronic Heating System.....	69
3.6.3.	Side by Side Comparison of Heating Systems.....	69
3.7.	Lighting.....	70

3.7.1.	Incandescent.....	70
3.7.2.	Fluorescent.....	70
3.7.3.	LED.....	71
3.8.	LED Drivers.....	72
3.8.1.	Internal vs External LED Drivers.....	73
3.9.	Lighting Control Protocols.....	73
3.9.1.	Phase Dimming.....	73
3.9.1.1.	Forward Phase.....	74
3.9.1.2.	Reverse Phase.....	74
3.9.2.	0-10V Dimming.....	75
3.9.3.	DMX-512.....	75
3.10.	Structure.....	75
3.10.1.	Material of Top Structure.....	76
3.10.1.1.	Pavers Over Heated Wires.....	78
3.10.1.1.1.	Paver Base.....	78
3.10.1.1.1.1.	Sand.....	78
3.10.1.1.1.2.	Concrete Fines.....	78
3.10.1.1.2.	Transparent Covering Over LED.....	79
3.10.1.2.1.	Plexiglass.....	79
3.10.1.2.2.	Fiberglass.....	80
3.10.1.2.3.	Water Sealant.....	80
3.10.2.	Material of Bottom Structure.....	80
3.10.2.1.	Wood.....	82
3.10.2.1.1.	Epoxy Resin Sealant.....	83
3.10.2.1.2.	Polyurethane Sealant.....	84
3.11.	Net Metering.....	85
3.12.	PCB Vendors.....	86
3.12.1.	Gold Phoenix PCB.....	87
3.12.2.	4PCB.....	87
3.12.3.	Express PCB.....	88
3.12.4.	Side by side comparison of PCB Vendors.....	88
3.13.	Existing Products and Technologies.....	89
3.13.1.	Solar Roadways.....	89
3.13.2.	Existing Technologies.....	90
<b>4.</b>	<b>Design.....</b>	<b>90</b>
4.1.	Software Design.....	90
4.1.1.	Microcontroller Logic.....	90
4.1.2.	Phone Application.....	91
4.1.3.	Communications.....	93
4.2.	Hardware Design.....	93
4.2.1.	Power Design.....	94
4.2.2.	Sensor Design.....	95
4.2.2.1.	Temperature Sensor .....	95
4.2.2.2.	Humidity Sensor.....	97
4.2.3.	Heating Element Design.....	98

4.2.4.	Lighting Design.....	98
4.3.	Structure Design.....	100
4.3.1.	Top Of Structure.....	101
4.3.2.	Bottom of Structure.....	103
<b>5.</b>	<b>Prototype and Testing.....</b>	<b>104</b>
5.1.	Software Standards and Testing Procedures.....	105
5.1.1.	Microcontroller Testing.....	105
5.1.2.	Phone Application Testing.....	107
5.1.3.	Communications Testing.....	109
5.2.	Hardware Testing.....	110
5.2.1.	Power Testing.....	111
5.2.2.	Sensor Testing.....	114
5.2.2.1.	Temperature Sensor Testing.....	114
5.2.2.2.	Humidity Sensor Testing.....	117
5.2.3.	Heating System Testing.....	120
5.2.4.	Lighting Testing.....	123
<b>6.</b>	<b>Administration Content.....</b>	<b>125</b>
6.1.	Milestones.....	125
6.2.	Budget.....	127
<b>7.</b>	<b>Conclusion.....</b>	<b>128</b>
<b>8.</b>	<b>Appendices.....</b>	<b>130</b>
8.1.	References.....	130
8.2.	Datasheet Links.....	136
8.3.	Permissions.....	137

# List of Figures

1. Requirements Table
2. Comparison of Conductor Coatings
3. Useful Conductor Properties and Comparisons
4. Power Communication Between Old to New Upgradable Options.
5. Common Problems and steps to Troubleshoot the Tile System
6. Common Problems and steps to Troubleshoot the Tile System Cont.
7. Photosensitive Epilepsy Patients EEG Response to Flickering Light
8. Hardware Block Diagram
9. Software Block Diagram
10. House of Quality
11. Comparison of the different RFID frequencies
12. Block diagram displaying the microcontroller's data path
13. Phone to web app to microcontroller data flow
14. Solar Power System Basics
15. Alkaline Battery Specifications
16. Diagram of Power Outlet Connection
17. The unit kcal (kilocalorie) is a unit of energy
18. Three Wire RTD Circuit with Wheatstone Bridge
19. Thermocouple Table Comparison Table
20. Temperature Sensor Data Comparison
21. Humidity Sensor Data Comparison
22. Comparison of Heating Installation Method
23. Heating System Comparison
24. Comparison of LED vs CFL vs Incandescent
25. Forward Phase dimming waveform vs. Reverse Phase dimming waveform
26. Top View of Structure with descriptions
27. Top View of Structure with dimensions
28. Top View of Structure with Separation of Materials
29. Side View of Structure with Descriptions
30. Side View of Structure with Dimensions
31. Side View of Structure with Separation of Materials
32. Net Metering Diagram
33. PCB Vendor Comparison
34. Mobile Application Mockup
35. Design Schematic
36. Design Schematic with labels of areas
37. Temp Sensor Datasheet
38. Temperature Sensor Schematic Snip
39. Humidity Sensor Schematic Snip
40. Typical application circuit of a WS2812B LED strip.
41. Top View of Structure with descriptions
42. Top View of Structure with dimensions
43. Side View of Structure with Descriptions
44. Side View of Structure with Dimensions
45. Microcontroller Testing Plan
46. Mobile Application Testing Plan
47. Communications Testing Plan
48. Hardware Testing Plan
49. Power Testing Plan
50. Temperature Sensor Testing Circuit
51. Initial Temperature Sensor Testing Plan

52. Prototype Circuit Temperature Sensor Test
53. Humidity Sensor Testing Circuit
54. Initial Humidity Sensor Testing Plan
55. Prototype Circuit Humidity Sensor Test
56. Heating System Sensor Test
57. Heating System Cable Test
58. Table to Describe Lighting Testing
59. Testing hardware design for LED
60. Project Milestones
61. Project Budget

# 1. Executive Summary

Snow and ice are a significant problem for roadways in colder climates. These conditions often result in school and business closures and require a lot of work to keep people safe and roads usable. It can take hours to shovel and spread salt and sand to keep properties safe and clear of snow and ice. The Department of Transportation (DOT) hires plow drivers that move snow while dropping sand and salt to keep roads safe. In the process of removing snow and ice the pavement on roads and driveways tend to get ripped up, the salt and sand put on the roads increase the rate that rust on the underside of cars forms. With technology advancing there should be an easier and smarter way to deal with these conditions.

The idea for this project is to create a new smart pavement tile that can be used for a driveway, walkway or roadway. This tile will incorporate external solar panels, integrated heating components, LEDs integrated into each panel and accurate sensors that can aid in automation. These tiles will be able to interlock into each other and make up a surface of any dimension. Along with these tiles there will be a user-friendly smartphone application that allows the owner to configure and manually control the main features of these tiles.

One of the most important features of this project is a heating system that is hot enough to melt snow and ice but will not burn or harm anything that makes contact with the tile. Another important feature of this tile is the ability to automate the heating system, in order to automate the heating system a system of accurate sensors is necessary. A temperature sensor and humidity sensor will be used and feed data to a microcontroller, based on the data provided the microcontroller will apply power on and off to the heating system. In order to power these tiles, a battery will be used along with external solar panels. The solar panels will be sized large enough to provide enough energy to maintain the battery. In a situation when the solar panels have not provided enough energy the battery can also be directly connected to an AC wall adapter. During the warmer months of the year when this system would not be used the solar panels would have the ability to inject power back into the grid through net metering and reduce energy costs for the home or business owner. Net metering would require additional components that would have to be provided by a power and energy company. Another main feature of these tiles are the integrated LED panels. Depending on the application of the tile the LEDs can be used for caution or road signs, Advertisement or open/closed signs for businesses or home decorations for holidays or events. Each LED panel will be configurable by the user-friendly smartphone application. The smart phone application will communicate between each tile using a Wi-Fi or Bluetooth connection.



The technology behind this project already exists and there are companies out there trying to produce similar products. This project as a product would be very marketable, if purchased by a homeowner there are huge benefits throughout the year, during the winter months their property is snow and ice free and during the warmer months their energy bill is cheaper if they are configured with net metering, if not the product would be most beneficial in cold climates. Similarly, business owners in cold climates would benefit because their parking lot and storefront can be snow and ice free along with utilizing the LEDs for advertising and information such as hours or whether they are open or closed. The DOT would benefit the most out of this product because they have the most roadways, if this product was used, they would no longer need plows, sand or salt. Along with these benefits the DOT would no longer need to paint or repave roadways and could save money on street signs, if these panels were connected directly to solar panels, they could generate power and aid energy companies operate more efficiently.

## **2. Project Description**

This section discusses the motivations, objectives and goals of the project along with the requirements and specifications that this project will have to meet in order to be successful. A verification statement is included with each requirement in order to determine what satisfies each requirement.

### **2.1. Motivation**

Colder climates are usually accompanied by snow and ice, these weather conditions can often be very dangerous to pedestrians and drivers. Aside from being a huge hazard making conditions dangerous they cause schools and businesses to close due to poor road conditions. Home and business owners spend hours shoveling and the DOT spends money on plows, this time and money can be spent more effectively with an automated pavement tile that is capable of removing snow and ice at easy and maintaining safe conditions.

The motivation for this project is to design and create a highly functional project that can change the way colder climate places deal with snow and ice on roadways, driveways and walkways. This project also provides a valuable opportunity to gain experience designing and integrating various hardware and software components. This project also provides the skills necessary to work as a successful engineer in the field after graduation such as communication, project management, time management and working as a team.

## **2.2. Objectives and Goals**

The objective of this project is to design and create a prototype pavement tile that has an automated system capable of melting snow and ice. The prototype tile will also include external solar panels and LEDs. These LEDs and the heating system can be manually configured by a smartphone application.

The automated system will be able to take accurate temperature and humidity readings based on sensor data and decide based on this data if the heating system is necessary. Another objective of this project is to design and create smart phone software capable of manually controlling the functionality of the prototype smart tile. This software will use a Wi-Fi or Bluetooth connection to communicate between the smartphone and tile. The software created should be user-friendly and intuitive to use by all users. In case an override is necessary the software should allow the user to fully control the heating and LED components of the tile. Another objective of this prototype is to utilize solar power to charge a battery capable of powering the tile. In order to achieve this a solar panel will be mounted external to the tile and wired into the internal battery of the tile, all power generated by the solar panel will be used to charge and maintain the battery. In a net metering configuration, the power from the solar panel would also be directed into the grid.

## **2.3. Requirements and Specifications**

The requirements and specifications were broken up into separate sections based on part of the project they are for. These requirements can be met by satisfying the verification statements included with each requirement. The Requirement ID can be used for traceability purposes and to keep track of each of these requirements. The proposed test section serves as a description of the test suitable to satisfy the requirement. These requirements and specifications are necessary and provide the value needed for the core functionality of this project to work properly and safely. Figure 1 displays all the hardware requirements, Figure 1 displays all the software requirements, Figure 1 displays the functionality requirements and Figure 1 displays the structural requirements.

**Figure 1 - Requirements Table**

<b><u>Req. ID</u></b>	<b><u>Requirement/Specification</u></b>	<b><u>Verification Statement</u></b>	<b><u>Proposed Test</u></b>
Req. 1	Temperature sensor shall provide accurate temperature readings within +/- 3 degrees of the actual temperature on the surface of the tile.	This requirement is satisfied if temperature data provided is within the specified +/- 3 degrees of actual temperature	Use an infrared laser thermometer to provide surface temperature compared to data provided from the temperature sensor.
Req. 2	Humidity sensor shall provide accurate readings of humidity in the air.	This requirement is satisfied if the humidity sensor provides a reading close to outdoor humidity	Compare sensor data to weather data provided from weather.com or other sites
Req. 3	Heating system shall not exceed a temperature of 50F	This requirement is satisfied if the heating system turns off at a temperature of 50F	While heating system is on monitor temperature with infrared laser thermometer and make sure it does not exceed 50F
Req.4	Each tile will include a rechargeable battery	This requirement is satisfied if the battery is able to be charged.	Use a current sensor clamp around the wires of the battery and see if there is a current draw from the solar panel to the battery.

**Figure 1 cont.**

<b><u>Req. ID</u></b>	<b><u>Requirement/Specification</u></b>	<b><u>Verification Statement</u></b>	<b><u>Proposed Test</u></b>
Req. 5	Sensor data is displayed on the smartphone application.	This requirement is satisfied if the smartphone application can display data from the temperature and humidity sensor.	Open the smart phone application and check sensor data.
Req. 6	A user- friendly smartphone application will be developed and used to control the main functionality of these tiles	This Requirement is satisfied if a smartphone application is used to control the heating system and LEDs of the tile.	Open the smart phone application and toggle the heating system and LEDs on and off
Req. 7	Each tile will be able to communicate with the tiles around them	This requirement is satisfied if 2 tiles can turn on LEDs at a time.	TBD

**Figure 1 cont.**

<b><u>Req. ID</u></b>	<b><u>Requirement/Specification</u></b>	<b><u>Verification Statement</u></b>	<b><u>Proposed Test</u></b>
Req. 8	The heating system shall turn on when the temperature is less than or equal to 38F and the Humidity is above or equal to 25%	This requirement is satisfied if the Heating system turns on when the sensor data is within the listed specifications.	Lower the temperature on the surface of the tile and add humidity to the air by misting water near the humidity sensor.
Req. 9	Each Tile contains indicator LEDs to let the user know what is happening, Green for Charging/Maintaining and Red for heating system on.	This requirement is satisfied if there are indicator LEDs that are capable of turning on for charging and heating.	While the system is connected to the solar panels the Green LED indicator light is on, while the heating system is on the Red LED indicator LED is on.
Req. 10	Each Tile will contain an integrated LED panel that is easily configurable through software.	This requirement is satisfied if the LEDs can be toggled on or off through software.	Toggle LEDs on and off through software.

**Figure 1 cont.**

<b><u>Req. ID</u></b>	<b><u>Requirement/Specification</u></b>	<b><u>Verification Statement</u></b>	<b><u>Proposed Test</u></b>
Req. 11	The tiles will be able to interconnect to other tiles in order to make up a driveway, walkway or roadway	This requirement is satisfied if 2 or more tiles can be connected.	Build multiple prototype housings and connect them together.
Req. 12	Each tile shall be durable	This requirement is satisfied if the tile can withstand rain, wind, snow and weight.	Water will be poured on the tile; other tests are not feasible for a prototype.

## **2.4 Standards**

There are many standards to take into account when designing a new system or project. This section will discuss the applicable standards for this project and how these standards were accounted for in the design and implementation of this project.

### **2.4.1 Electromagnetic interference (EMI) standards**

Electromagnetic interference is inevitable when working with electronic devices and electrical components. Electromagnetic interference can travel through the air as a radio frequency wave or can be generated by active conductors. This type of interference can result in poor performance or failure of operation of nearby electronic devices. In some situations electronics and electronic devices or components can be the difference between life and death. Due to this industries and government groups have worked together to develop standards necessary for Electromagnetic interference for electronic devices. Since this project utilizes electronic devices and utilizes Bluetooth as a transmitter and receiver, it is important to understand and adhere to these standards [1].

## **2.4.1.1 Federal Communications Commission**

The federal communications commission is a government agency that is in charge of all communication systems and any interference or issues related to communication systems. Part 15 of the federal communications commission covers radio frequency devices and electromagnetic interference standards. Part 15 is separated into eight subparts, of these eight subparts three are applicable to this project, Subpart A, Subpart B and Subpart C. Subpart A is an overview of general radio frequency information, Subpart B covers unintentional radiators or unintentional emission, and Subpart C includes intentional radiators and intentional emission. The electronics included with this project will fall into Subpart B and Subpart C of part 15 of the federal communications commission. All measures will be taken to reduce and provide the lowest radiation and emission of radio frequency waves and noise as possible to prevent interference of electronic devices nearby. This project will be utilizing a Bluetooth module to connect to a smart phone application, in this case there will be some intentional emission however they will comply with subpart C of the federal communication commission [1][2].

## **2.4.1.2 ANSI C63.4**

ANSI stands for American National standard institute, this institute produced the necessary testing standards for electromagnetic interference testing. The ANSI C63.4 goes hand and hand with the federal communications commission part 15 and provides the necessary testing standards to comply. This testing standard includes methods for testing radio frequency emissions from electronic devices and components that operate in the frequency band of 9 kHz up to 50GHz. This testing standard is applicable for industrial, commercial and residential use of electronic devices, the intended test is to vary the frequency from 9 kHz up to 50 GHz and measure the electric field emission and magnetic field emission. This standard is applicable to this project to test the emission of electromagnetic interference from the electronics utilized [3].

## **2.4.1.3 IEC EN61000**

IEC stands for the International Electro-technical commission, this agency is responsible for coming up with standards necessary for all electrical devices and electronic technologies. The IEC 61000 is part of the generic Electromagnetic capability standards that covers the electromagnetic compatibility (EMC) emission standards for residential, commercial and light industrial environments. This standard is broken up into six subparts that cover different situations and frequency bands. IEC 61000 6-1 covers the immunity for residential, commercial and light industrial environments operating at frequency of 0Hz to 400Hz. This

section is applicable to this project because the project will mostly be used in a residential area between the specified frequencies, the standard states that if there is no emission requirement then there is no test needed. IEC 61000 6-3 is applicable because it covers emission standards for commercial, residential and light industrial environments, it states that unless a requirement is specified that testing is not required for emissions. For this project the electromagnetic interference should be minimal to none [4].

## **2.4.2 Sensor standards**

Sensors are used in most modern day systems to help gather data and make smarter devices capable of improving performance and automation of tasks. In this project two types of sensors were used to automate the process of turning on and shutting off the heating system. These sensors had to adhere to necessary standards before they were put to use, this section discusses these standards.

### **2.4.2.1 IEC standards**

The International Electro-technical Commission put in place standards that address a sensor's ingress protection against the water and dust in the environment when in use. This standard is often referred to with IPXX where the 'X's represent numbers, the first number is how dustproof the sensor is. Dust proofing ranges on a scale of 0 up to 6 with 6 meaning the sensor is completely dust proof. The second digit in the standard represents water protection and ranges from 0 up to 9k with 9k meaning the sensor is completely water protected at high pressures and high temperatures. The sensors utilized in this project adhere to these specifications and are both dust and water protected on the ranges listed in this standard [5].

## **2.4.3 Printed circuit board standards**

A printed circuit board or PCB is a flat board composed of composite, fiberglass, epoxy or other laminate materials, this board contains etched pathways that conductors can be printed or laid in. Most modern day electronic devices utilize a PCB in order to consolidate and connect their electrical components in one place. The use of PCBs makes it easier to make smaller electronic devices and swap out components if one fails. In this section some of the applicable PCB standards will be discussed.

### **2.4.3.1 IPC-2152**

IPC stands for Institute of printed circuit boards (PCB) IPC-2152 is a standard developed for the current carrying capacity in a PCB. This standard was put in



place to properly size traces within PCBs to allow proper current flow. This standard states that the size of a conductor within a PCB is determined by the cross-sectional area. As the cross-sectional area increases the current carried in the conductor also increases. The current carried through a trace on the PCB is affected by many different factors including the material the board is made out of, thickness of the board, the number of copper planes throughout the board and the environment. This standard also states that for manufacturing purposes the conductor width should be maximized and the conductor spacing requirements should be satisfied. The minimum conductor width stated in this standard is 0.1mm wide and the maximum width is as large as the PCB will allow while maintaining spacing. For this project the PCB will be designed using a software tool and the actual PCB will be subcontracted and manufactured by a company separate from the team working on this project. The company that manufactures the PCB will have to adhere to these standards in order to produce a quality product capable of meeting this project's requirements [6].

### **2.4.3.2 Soldering standards**

Soldering is a technique used to join electrical connections together, for this project the printable circuit board (PCB) will utilize solder joints to mount and connect circuit components. In this section the applicable soldering standards will be discussed along with how they impact this project. This is important because these solder joints are responsible for the electrical connections and integrity of the system. If these solder joints are not done properly or up to these standards the system has the potential to be inoperable or cause other components to fail.

### **2.4.3.3 IPC J-STD-001 & IPC-A-610**

IPC stands for institute for printed circuits and is responsible for some of the standards necessary for PCB design and manufacturing. IPC-J-STD-001 is a standard in place for material and processing requirements, this standard is crucial for manufacturing. This standard includes the materials, methods and verification standard for creating high quality solder interconnections. This standard focuses on the hand skills necessary to produce high quality solder connections and recommends taking a course with a certification to enhance performance and credibility. IPC-A-610 is a standard in place for post assembly utilized to verify that the assembly meets the acceptance requirements. IPC-A-610 goes hand and hand with IPC-J-STD-001, both of these standards are applicable to this project because components will need to be hand soldered to a PCB and their physical connections along with the appearance of the PCB are important to achieving the goal of creating a success project.

### **2.4.3.4 NASA-STD-8739.3**

NASA stands for the National Aeronautics and Space Administration and is responsible for most of the United States space travel and exploration. The NASA-STD-8739.3 is a standard put into place to ensure that soldered electrical connections are reliable and provide physical integrity capable of space travel. In order to comply with this standard, other standards must also be followed and satisfied, this includes preparing the material being soldered with Isopropyl alcohol, Ethyl alcohol and methyl alcohol following standards TT-I-735, O-B-760, and O-M-232. Aside from preparing the material another standard that must be satisfied is NHB-5300.4 which is a standard in place for electrostatic discharge control. NASA also follows NHB 1700.1 which is a safety policy and requirements document and standard NHB 8060.1C which covers flammability, odor, off gassing compatibility and test procedures for materials that support combustion. Adhering to this standard goes well above and beyond this project's expectations however if a solder joint can stand up to extended space travel and combustion, then it should be strong enough to last on this project [7].

### **2.4.4 Insulated Conductors Standards**

Choosing the right conductors for our Tiles will be very important because, depending on the amount of Tiles that are connected, this will change the amperage running through each. We currently plan to use insulated wires that are capable of carrying a minimum limit of 15 Amp, which is the average standard electrical outlet standard before tripping a circuit breaker. This will allow the ability to daisy chain tiles together before needing another circuit breaker and outlet to use. The insulated wires will need to be an industry standard, that is capable of working in Low and high temperatures, and can be able to withstand bends, pressures and a long lifespan of unplugging and replugging connection. Standards were developed and used in practice everyday by leading industries which can help us choose the right conductor and insulator combination. [8]

**Figure 2** - Comparison of Conductor Coatings

Comparison of Conductor Coatings			
Characteristics	Tin Plate	Silver Plate	Nickel Plate
Life Stability	Conductivity and solderability deteriorate with heat aging at rated temperature due to migration of tin and copper and tin oxidation	Excellent - No loss of conductivity with heat aging at rated temperature. Solderability shelf life remains good.	Conductivity remains stable with heat aging at rated temperature.
Crimp Terminability	Good - But contact resistance increases with time and can be variable.	Excellent - Contact resistance remains low.	Good - But contact resistance may vary with time. Use plated steel terminal in some cases.
Solder	Good originally. Deteriorates with shelf life.	Excellent.	Requires active Flux.
Service Temperature	150°C	200°C	250°C

**Figure 3 - Useful Conductor Properties and Comparisons**

<b>Conductor Properties and Comparisons</b>					
Material	Max Operating Temp.	Corrosion Resistance	Solderability	Flex Life	Price
Copper	150°C	Good, poor Oxidation Resistance	Fair	★★	\$
Tin Plated Copper	150°C	Good	Good	★★	\$
Silver Plated Copper	200°C	Poor	Good	★★	\$\$\$
Nickel Plated Copper	260°C	Good	Poor	★★	\$\$
Copper Covered Steel	200°C	Good	Fair	★★	\$\$
High Strength Alloy	200°C	Poor	Good	★★★	\$\$\$\$
Stainless Steel	870°C	Good	Poor	★★★	\$\$\$

The IPC-2221 conductor width standard was developed to guarantee safe communication of electric current into a conductor on a printed circuit board (PCB). This standard maintains printed circuit board Manufacturers to use a simple power draw calculation to plan a suitable width for the conductive traces for the printed circuit board. If conductor traces are not up to scale and do not have a wide enough area, it can cause intermittent problems that do not allow enough current to flow or may cause the trace to overheat which may also lead to a safety risk. [9]

### **2.4.4.1 Receptacle & Connector Standards**

Since the Tile will incorporate the use of an electrical outlet or receptacle, we would need to use the correct outlet mated to the correct connector. The Power for the system will mainly come from the receptacle, and will supply most of the high voltage and current needed for the Tile system. The receptacle will not be supplied with this project, however will need to be utilized by the Tiles. The Tiles will connect to the receptacle with an electrical cord with a plug on the end to mate into the connector. Common household electrical outlets supply 15 amps to 20 amps. The Tiles will most likely utilize the 15 Amp plug, because this will allow the plug to fit into both a 15 amp and 20 amp electrical outlet. If the Tile were to utilize a 20 Amp plug, it can only fit into the 20 amp electrical outlet and not a common 15 amp outlet due to the rotated pin on a 20 amp plug. The 2 main plus we will consider for the Tiles are the 15 amp two prong plug that has a Neutral Pin which is oversized for correct polarity connection, and the 15 amp three prong plug that includes an additional prong called the ground pin, both plugs have a Line pin. [10]

### **2.4.5 Power Switchgear, Circuits and Fuses Standards**

Choosing the right Electrical Protection for any Electrical circuit is key for safety and long life. Since the Tiles will incorporate a system of various voltages, such as high voltage up to 120 V and low voltage as low as 5 V, we would need a well designed electrical switchgear, that can regulate, meter and control the electrical power system. Like all electrical devices, it is extremely important to monitor and control every single aspect, doing this can save a business money, time and increase safety. The possibilities of an overload in a system is great, because once the Electrical power is generated, it needs to be transmitted, distributed and converted to useful energy sources with correct voltage and amperage ratings to be used in electrical equipment. If any part of this chain is overloaded, for whatever reason, it is of crucial importance that a switchgear is used to protect all components inside this chain of devices. Having a robust system can save one from catastrophic consequences of expensive equipment and endless hours of labor cost. Switchgears are commonly made up of electrical disconnect switches, fuses and circuit breakers, all of these work together to ensure the device will be protected in case of faults. The Tiles will incorporate its own type of circuit protection for each the low voltage and high voltage areas. The heating element will be supplied by the high voltage side, and this voltage will be from the home voltage, which is recommended to already have its own circuit breaker for the outlets being used. The control side, or low voltage side will implement its own circuit breaker but rated for lower voltage. Both sides of the circuit will also use an inline fuse to help with additional safety measures, this will allow the fuse to

break contact in case the circuit breaker fails. The fuse for the low voltage side will be inline close to the battery, less than 18" away. The closest the fuse is to the terminals will ensure the maximum reliability. Circuit breakers and fuses are not interchangeable for all power applications. For instance, a fuse should not be used in situations that require a Ground-Fault Circuit Interrupter (GFCI). This Tile Project will incorporate its very own circuit protection. [11]

Fuses:

- One time use only, but cheaper than Circuit breakers
- Various voltage and current ratings
- Faster current interrupting device than a circuit breaker
- Readily available and easy to replace

Circuit Breakers:

- Multiple Use after resetting, more expensive than fuses
- Various voltage and current ratings, safer and can prevent electric shock with a GFCI circuit rather than just overheating protection.
- Slower current interrupting device than a Fuse protected device
- Easy to reset

## **2.4.6 Power Systems Communications Standards**

Power system communication is a protocol that will be very helpful in the growth of the Tile product, the main objective to achieve with a communication standard is the ease of upgradability by saving time and minimizing system configuration. IEC-61850 is a standard that can help with the adaptability of a communication system. These standards were started to be introduced in the late 1970's, and soon after quickly adapted to power system configurations. The main purpose was to have various computer systems and the ability to exchange information between each other, by various vendors to simplify the integration of parts and communication networks, this was a term referred to as interoperability. Interoperability leads to more efficient designs by allowing products to be modified in the future, lower installment cost and for independent testing. This is something which can benefit any product over a long period, because while it is best to design a system for its intended use right now, without room for upgradability in the network and software, there will not be room for growth of that product. However, if we build a software that can adapt, and be modified to accept new power modifications then we can always expand. For example, the Tile system will need a way to communicate with other Tiles, since the Tiles will be connected to each other, the power flow through each would need to be accounted for. Typically all interconnected networks that connect the generation, transmission and distribution should be able to communicate with each other. However, sometimes this can lead to security concerns and it is sometimes recommended to design by subsystems. This standard IEC-61850 takes account

for the communication networks usually has greater technology advances at a much higher rate than the power system infrastructure, so allowing room to expand to a new power system with the least amount of effort will benefit greatly. [11]

Since the Tile system will allow power transfer from one Tile to the next, we can implement a system and follow IEC-61850 to allow future upgrades with much ease as possible. The Tiles will implement various protocols of communications, and various power transfer methods. To begin, the Tiles will need to read the voltage of the solar panel output to allow proper charging of the battery and to let users know through the application when the battery is fully charged or if the battery is depleted. This can also let the user know if the batteries are even receiving a charge to help troubleshoot power connections. The Tile will also be supplying voltage to various sensors and reading various voltage changes in these sensors to allow proper voltage transfer from the battery or mains supply. The Tiles will need to also know when power transfers occur, and following a standard such as the IEC-61850, makes it very easy to stay updated in a competitive market, allowing expandability by being able to use these voltage readings to implement new vendors, aftermarket or OEM add ons. Figure 4 shows how adding a new accessory from another vendor can easily communicate with the original inputs, and power output controls.

**Figure 4** - Power Communication Between Old to New Upgradable Options.

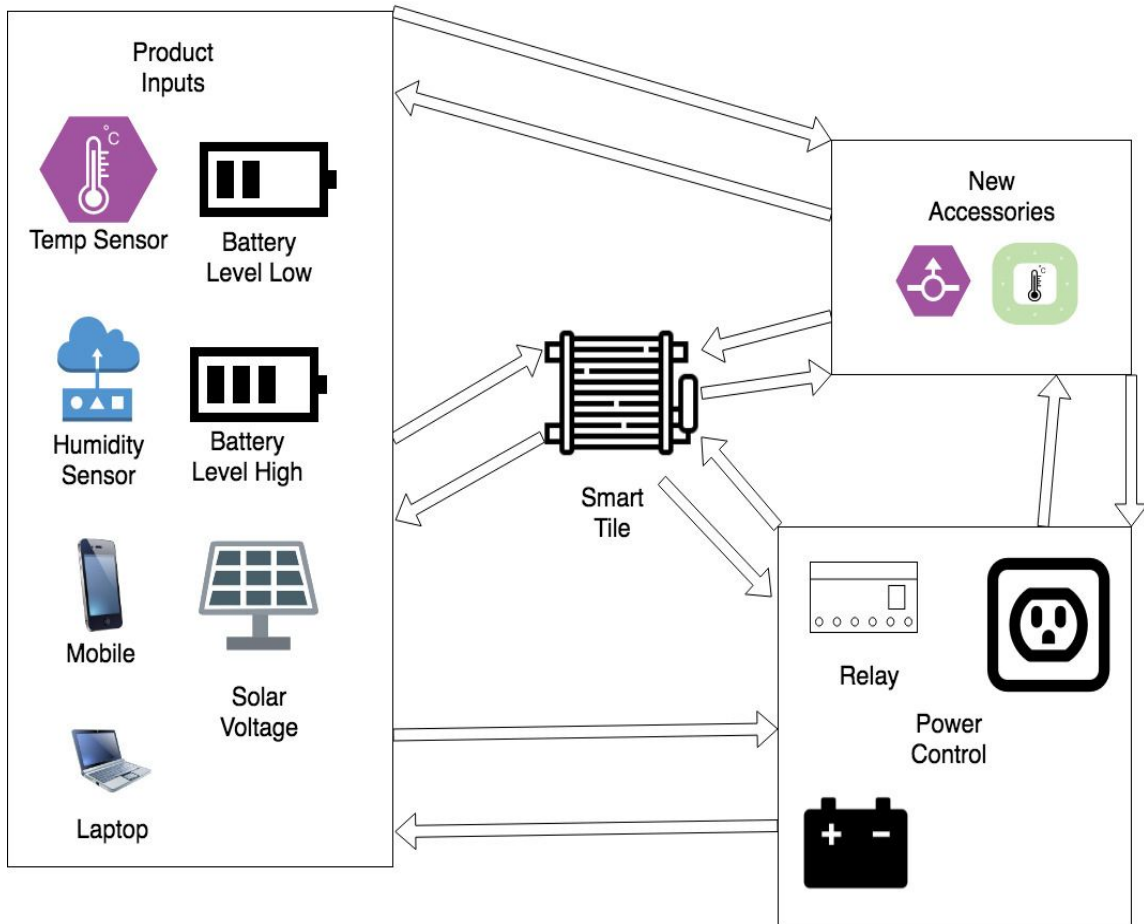

## 2.4.7 Surge Protection Devices Standards

It is common to supply various voltages to various subsystems on a circuit, due to components that work in a certain voltage range. The power supply is an essentially critical part of the Tile system, and protecting the circuit and all components is highly recommended. Even though the Tile system will incorporate its very own internal protection like many other manufacturers recommend protecting all outlet circuit devices with a surge protector. The Tile will also need to be used with a surge protection device such as a surge protector that can defend against potential voltage spikes that could harm the Tiles electronics and internal components. It is important to know that the Tile may use a lot of power and in a case of an electrical surge, the high current pull may cause fluctuation in power flow. Anytime the stream of electricity is changed or interrupted, a surge can occur. There are many internal causes of surges as well. Internal surges can be made by the process of contactors, relays, or breakers. The switching of capacitor banks, discharge of inductive devices, starting and stopping of any electric loads are also causes. [12]



## **2.4.8 Power Testing, Instrumentation and Measurement Standards**

Having a safe way to diagnose and test the Tiles and all subsystems of the Tile Product will need to be understood fully before attempting any repairs or replacement. Mostly all the components that will be used in the Tile systems will for the most part be serviceable to the end user, doing this will increase the lifespan, and overall value and quality of the product. From previously mentioned before, by having a system that can be used to communicate with all other subsystems will really help with diagnosis of the Tile. For instance, a problem occurs to an end user such that the Solar Panels will generate electricity, however the battery does not charge. The user, or technician should be able to troubleshoot this problem rather quickly. First we can start by measuring the voltage coming into the battery, and compare it with the specifications of the solar panel/ inverter, If this is within specifications we can move on to say there may be a drain in the system elsewhere, or a faulty battery. If the Voltage is not within specifications, we can look at the solar panels / inverters as being faulty. The application will be used to also keep track of data that can help visualize this communication process to help find and fix any intermittent or faults. Looking at Figure 5 below can summarize some common problems and lead to quick repairs.

**Figure 5:** Common Problems and steps to Troubleshoot the Tile System.

Problem:	TroubleShoot / Solutions
No Power	<ol style="list-style-type: none"> <li>1. Ensure Home Circuit Breaker is not Tripped</li> <li>2. Verify Operation of Outlet Circuit Breaker</li> <li>3. Verify Battery is connected</li> <li>4. Check Internal Fuse Continuity</li> </ol>
Battery Does Not Charge	<ol style="list-style-type: none"> <li>1. Check connections and polarity from Solar Panels to battery</li> <li>2. Measure voltage output with DMM from Solar Panel (Check Required Specifications)</li> <li>3. Load Test Battery</li> <li>4. Using DMM, Test battery for any Parasitic draw</li> </ol>
Heating Element Not Working.	<ol style="list-style-type: none"> <li>1. Verify Tile is On with APPLICATION</li> <li>2. Verify the proper conditions have been met through application</li> <li>3. Ensure Battery, and Outlet are connected properly</li> <li>4. Using DMM check voltage of Battery and Outlet, is within specifications</li> <li>5. Disconnect Power,</li> <li>6. Verify Relay operation Using DMM</li> <li>7. Using DMM Check Continuity of Heating Element</li> </ol>

Continuing off of power testing, the Tiles will have various sensors, LEDs, Heating elements and other options to choose from that will need their own power source and power Voltage, Knowing these voltages can help with troubleshooting to find problems, intermittents and faults much faster. Figure 5 shows the major components and their working input and output voltages.

**Figure 6** - Common Problems and steps to Troubleshoot the Tile System Cont.

Component	Input Voltage	Output
Microcontroller	5 V	0-5 V (Analog Read)
Relay	5 V (Low Voltage Side)	120 V (Switching Side)
Solar Panel	-	TBA
Battery	TBA	12 V
Heating Element	120 V	TBA
Temperature Sensor	5 V	0-5 V (Analog Read)
Humidity Sensor	3.3V to 5 V	0-5 V (Analog Read)
Transformer 1	TBA	TBA
Transformer 2	TBA	TBA
AC to DC Convertor	AC Voltage TBA	DC Voltage TBA
DC to DC Convertor	DC Voltage TBA	DC Voltage TBA
LED	TBA	TBA
LED Driver	TBA	TBA

## 2.4.9 LED Light Flickering and Potential Health Concerns

LED flickering was a health concern around 2010; therefore, the IEEE Standards Working Group formed IEEE PAR1789 to advise the lighting industry of some of these concerns. The health effects from flickering can essentially be separated into two categories: immediate results and results of long-term exposure. The main immediate result of just a few seconds of exposure can be symptoms of epileptic seizures, whereas the results of long-term exposure are symptoms such as headaches, migraines, and impaired visual performance.

In the world, there are around 1 in 4000 people that live with photosensitive epilepsy. Flickering or repetitive flashing lights could trigger a seizure in these individuals. Flash frequency is one of the factors that may affect the likelihood of seizures. It is any repetitive change in a visual stimulus within the frequency range 3 Hz to 70 Hz. In Figure 7 below, results from a study show the

percentage of patients with photosensitive epilepsy exhibiting epileptiform EEG responses to the flicker from xenon gas discharge lamp shown as a function of flash frequency. A few of the other factors that contribute to this are brightness, contrast, distance, location, wavelength, and even open or closed eyes. Bright flickering lights are actually more dangerous when one's eyes are closed because the entire retina is then stimulated. In America, the frequency of alternating current electricity supply is 60Hz. With that being said, that is the "danger zone" so to say of a frequency that could cause a seizure in someone that is susceptible to them. Therefore, the drivers that control LED's must be adjusted such that the frequency is higher to not affect these individuals, or if the frequency range is to stay in the 3-70hz range then flickering must be eliminated. [13]

**Figure 7** - Photosensitive Epilepsy Patients EEG Response to Flickering Light  
(Permission requested from IEEE Xplore)

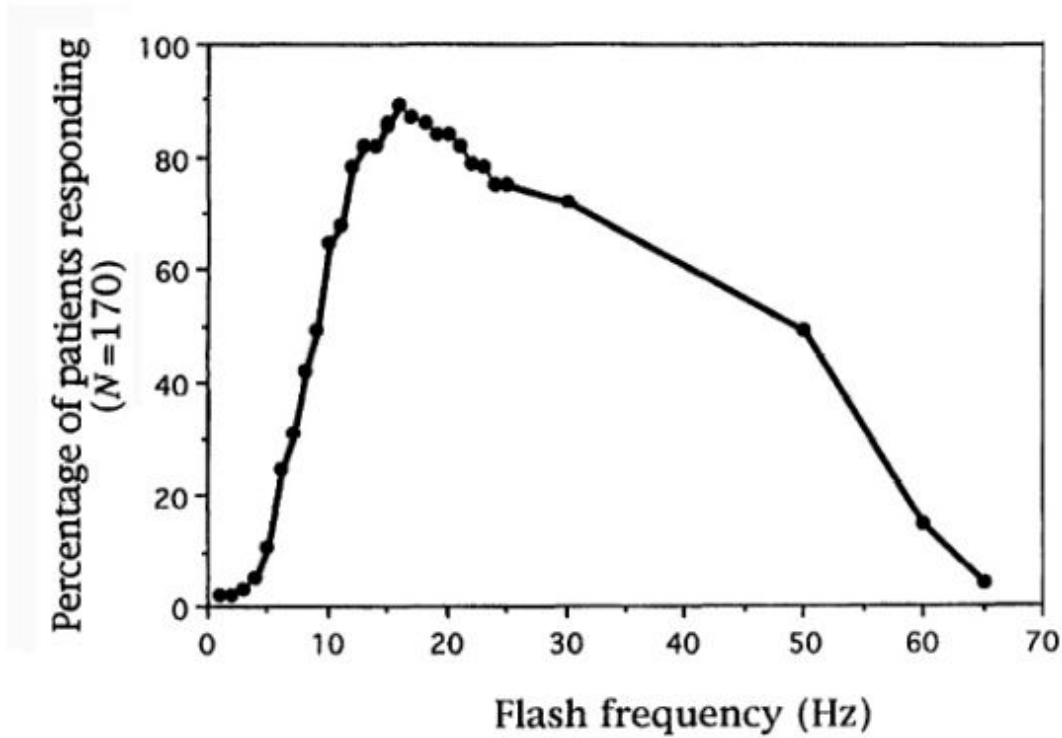

## 2.4.10 Minimum Lighting Standard

Lighting has been recognized as a very important factor when it comes to construction. Especially in the workplace, lighting contributes to organizational production and efficiency. The OSHA (Occupational Safety and Health

Administration) has established guidelines in lighting, specifically for the minimum amount of lighting that is required. There are 4 different areas that have been designated as needing a minimum lighting requirement in terms of footcandles (ftc). In general construction such as warehouses, corridors, hallways, and exit ways, the minimum amount of lighting needed is 5ftc. For concrete placement, evacuation and waste areas, loading platforms, active storage areas, refuelling, and field maintenance areas must be lit to a minimum of 3ftc. General construction plants and shops, indoor bathrooms, and mess rooms must be lit to 10ftc. Lastly, first aid stations, infirmaries, and offices must be lit to 30ftc. The main goal for this project is to create a prototype that can be expanded at a later time. If this project were to be expanded for use as a commercial construction walkway for instance, then the 3ftc requirement would have to be met. [14]

## **2.4.11 Safety Standards for LED Products**

Back in 2007, many agreed that of the up and coming revolutionary technologies in the lighting industry, LED's would most radically change the market in the foreseeable future. Those people ended up being correct, and LED lighting took the lighting market by storm in the coming decade. Like all new products, requirements for safety had not yet been identified; therefore, UL worked on many sets of requirements specifically for LED lighting to ensure that this new technology enjoys the same level of acceptance and consumer confidence as other lighting technologies. There are three specific risks that UL touched on that LED manufacturers must consider when designing their products: risk of shock, risk of fire, and biological hazards. For risk of shock, there are two installation applications that need to be considered: LED's supplied by a Class 2 supply, and LED's that are connected by a non-Class 2 supply or otherwise known as line connected. Due to voltage and current limitation in Class 2 there is not much of a shock hazard. However, non-Class 2 applications must comply with standard insulation and accessibility requirements. When it comes to the risk of fire, like it was with the risk for shock, Class 2 power supplies reduce the risk due to the limited electrical energy used in those devices. However, there has been evidence that an LED itself can exceed 90 degrees C due to the thermal energy dissipated by an LED when converting electrical energy to light. This issue causes concern because 90 degrees C is the maximum that is allowed per building code in the US on combustible surfaces. LED designers must take this into account to ensure that all components within an LED luminaire and the outside surfaces are operating within their specific temperature ratings. Lastly, biological hazards are considered by UL to be something that needs to be accounted for when designing LED's. Most lighting before LED's had some health issues whether it was retina damage or some causation of headaches and migraines, but there isn't any conclusive research that proves biological hazards to be a significant risk when using LED technology. Just like all other light

sources, a diffuser can possibly mitigate personal injury risks from electromagnetic radiation that is produced. [15]

## 2.4.12 ANSI Common Terminology

The American National Standard Institute (ANSI) worked on a datasheet that would apply to white LEDs used for general illumination. Unlike incandescent and fluorescent light, LED is not standard per device. It depends on the chip that the LED is made on. Because of that, there were some issues when LED's first came out when it comes to standards in light output, color correlated temperature (CCT), and dimming capabilities. This datasheet that ANSI decided to create does not standardize LED package shape, footprint, or other physical parameters but rather the information being communicated between LED manufacturers and the rest of the lighting industry. This is to ensure consistent and fair comparisons.

In the performance characteristics area, most datasheets address photometric performance: lumens and CCT. Most LED manufacturers post information in their own datasheets for CCT vs luminous flux, color binning, luminous intensity distribution, luminous efficacy, etc. Some info is presented as a table and others are listed in graphical formats. There are a few other issues that must be included in datasheets. One of the main issues is thermal degrading since LEDs are temperature dependent devices. Most of the time all temperature related characteristics are provided in LED datasheets in a graph. Operational characteristics such as thermal and electrical characteristics, and dimming type, forward voltage vs forward current, forward voltage binning, forward current versus temperature, and forward voltage vs temperature are all included as well. Next thing that is typically covered in a datasheet is physical and electrical connection characteristics. This is typically in the form of a block diagram or a one line. This is for installers of the products to ensure proper connection points. Most of the time just the external connection points are included; however, it is recommended that the diagram of the internal diode is also included. The last couple of items that are included are usage recommendation (which is self explanatory) and packaging information. This is important because LED lighting, especially in commercial construction applications, is typically bought in bulk and shipped in large amounts. Storage is a very important topic for installers.

The ANSI LED standard datasheet intent is to ensure more accurate, consistent, and reliable data is provided by LED manufacturers to consumers. ANSI does not intend for this to put additional burdens on LED manufacturers when establishing their own datasheets. Ideally there is a balance to the benefits and burdens of such a standardization. The end hope is this: consistent communication between LED manufacturers and users provides a valuable tool to further assist and grow the LED industry. [16]

## 2.4.13 Bluetooth Standards

Standardization of Bluetooth devices used to be managed by the IEEE 802.15.1 specification until the supergroup Bluetooth Special Interest Group (SIG) took over managing the standards required to produce and manufacture bluetooth devices. Bluetooth is a trademarked name and all Bluetooth devices must be tested and qualified by Bluetooth SIG. Bluetooth SIG is in charge of qualifying and giving the go-ahead for companies to manufacture Bluetooth devices safely. The microcontroller that will be used uses the WiFiNINA module that has an integrated Bluetooth 4.2 component. The manufacturer of WifiNINA, being a product that is sold on the market, has passed Bluetooth SIG's qualification test since it is available for the general use. [17]

## 2.4.13 Wi-Fi Standards

The microcontroller will have the ESP8266 Wi-Fi module that the microcontroller will communicate over WPAN. Wi-Fi usage for WPAN (Wireless Personal Area Network) standards fall under IEEE 802.15 specifications. It is self-contained and follows the SOC TCP/IP model that the IEEE specification requires. This model ensures that the connection is secure to prevent bad actors with malicious intent to tamper with the data transmission. TCP/IP is a layered model that includes the Application Layer, Transport Layer, Internet Layer, and Network Layer. This is a worldwide standard developed to make communication across Wi-Fi systems cohesive and simplified across devices so that each manufacturer doesn't have their own model that must be translated per device. [18]

## 2.4.14 RFID Standards

RFID has many differing standards depending on the type of RFID transmitter/receiver combination, frequency used, and type of application that the RFID system is used for. The class of RFID that would be considered for this project would be "Class 4: an active tag that uses a built-in battery to run the microchip's circuitry and to power a transmitter that broadcasts a signal to a reader," therefore the RFID tag and transmitter would be implemented in such a way that it meets the criteria for it to be used under the Class 4 standardizations for RFID. [19]

Another standard RFID has depends on the frequency that the RFID is using for communication. The ISO 18000 series of standards defines these ranges. Since the communication would happen over a high frequency RFID transmitter/receiver, the 18000-3 class of standards would be required since it designates these types of transmitter/receiver couples as outputting signals at 13.56 MHz [19]

## **2.5 Constraints**

Constraints can often make a project or task more difficult than it needs to be. In this section the constraints that are applicable to the implementation and design of this project will be discussed along with the Impact that they had on the project.

### **2.5.1 Economic Constraints**

The cost of designing and implementing this system is being funded by the group without any help from the University or sponsors. Due to this constraint testing of many different circuit components and heating elements is limited. This makes it difficult to select the right component on the first attempt. In order to mitigate the risk of choosing less effective or bad components and still maintain a cost effective functional prototype, extensive research was performed during the design phase of this project. Aside from extensive research a lot of modeling and planning was performed to make sure the components chosen were the correct components for the task. Another economic constraint at the time this project is being designed is COVID19. Due to COVID19 more people are out of work or home quarantining causing a shortage on the supply of components which directly affects the cost of the components that are available.

More extensive testing and higher quality components could be used in the production version of this product however the cost of the tile may increase to compensate for these changes.

### **2.5.2 Environmental Constraints**

In order to protect and preserve our planet more and more people are switching to a renewable energy source and utilizing “green” clean energy and technology. By switching to renewable energy sources and utilizing “green” technologies people are able to reduce emissions into the atmosphere, while designing this project these concerns were kept in mind and taken into account. The system was designed to utilize a solar panel as a renewable energy source.

The initial plan for this project was to provide power to the entire system solely through a solar panel and battery. Unfortunately some of the components used in this project required more power and would drain the battery at a substantial rate. Due to this constraint AC power was required from a wall outlet. Upon realizing this a compromise was made that AC power from the wall would not be the primary power source and only provide power to the components that require it or in a situation when the battery is very low or dead it can be used as backup power. In all normal operating cases a solar panel will be used to charge the battery and the battery will be used to power the system with the exception of the



heating element. Aside from utilizing a solar panel to charge the battery, all of the components aside from the heating element do not require a lot of power to operate.

### **2.5.3 Safety Constraints**

Snow and ice can be very dangerous and the removal of snow and ice is necessary in colder climates to maintain safe conditions. One of the primary goals of this project is to provide a product that aids homeowners, business owners and potentially the department of transportation remove snow and ice off the pavement in a quick and effective manner.

One of the constraints for the design of this project is the temperature that the tile can heat up to. When designing this project, the temperature of the tile was one of the most important things to take into account and designed very carefully. Not only will humans be stepping on the surface of these tiles but also insects and animals. In order to mitigate the risk of injury or harm the temperature of the tile has a fixed range and a maximum temperature that can be reached. Along with the temperature limit there is also an indicator LED specifically used for the heating system, when the heating system is in use the LED indicator will illuminate and when the heating system is off the LED is also turned off. Another safety feature that was added due to the concern of snow and ice was a backup power source, in the event that the battery dies a relay will switch the power source to AC power from the wall outlet. Snow and ice should be removable in any situation with this product. Another feature added in to ensure the safety was a manual override, this feature will allow the user to manually turn on and off the heating system from the smartphone application. In the event of an emergency where there are damaged components the system can be manually shut down.

### **2.5.4 Ethical Constraints**

One ethical constraint of this project was to keep people safe by creating a product that promotes safe road conditions. Another ethical constraint of this product was to utilize clean “green” energy, this was done by implementing a solar panel to charge the battery. Over all the intentions and decisions made for this project by each group member were ethical.

### **2.5.5 Political Constraints**

For the prototype and completion of the initial project it was determined that no political constraints are applicable. Being that the department of transportation is a part of the government, in the future if this project is manufactured and turned into a product funding from the department of transportation for roadway tiles would be a political constraint.

## **2.5.6 Cultural Constraints**

Through thorough research it has been determined that there are currently no applicable cultural constraints that affect the design or implementation of this project or prototype.

## **2.6 Block Diagrams**

Below are the block diagrams for the hardware and software components of this project. They provide a high level view of the system and how each component communicates with each other to form the internals of the smart tile system. The hardware and software block diagrams show by arrow direction which way the flow of communication goes between each part of the system.

## 2.6.1. Hardware Block Diagram

Figure 8 - Hardware Block Diagram

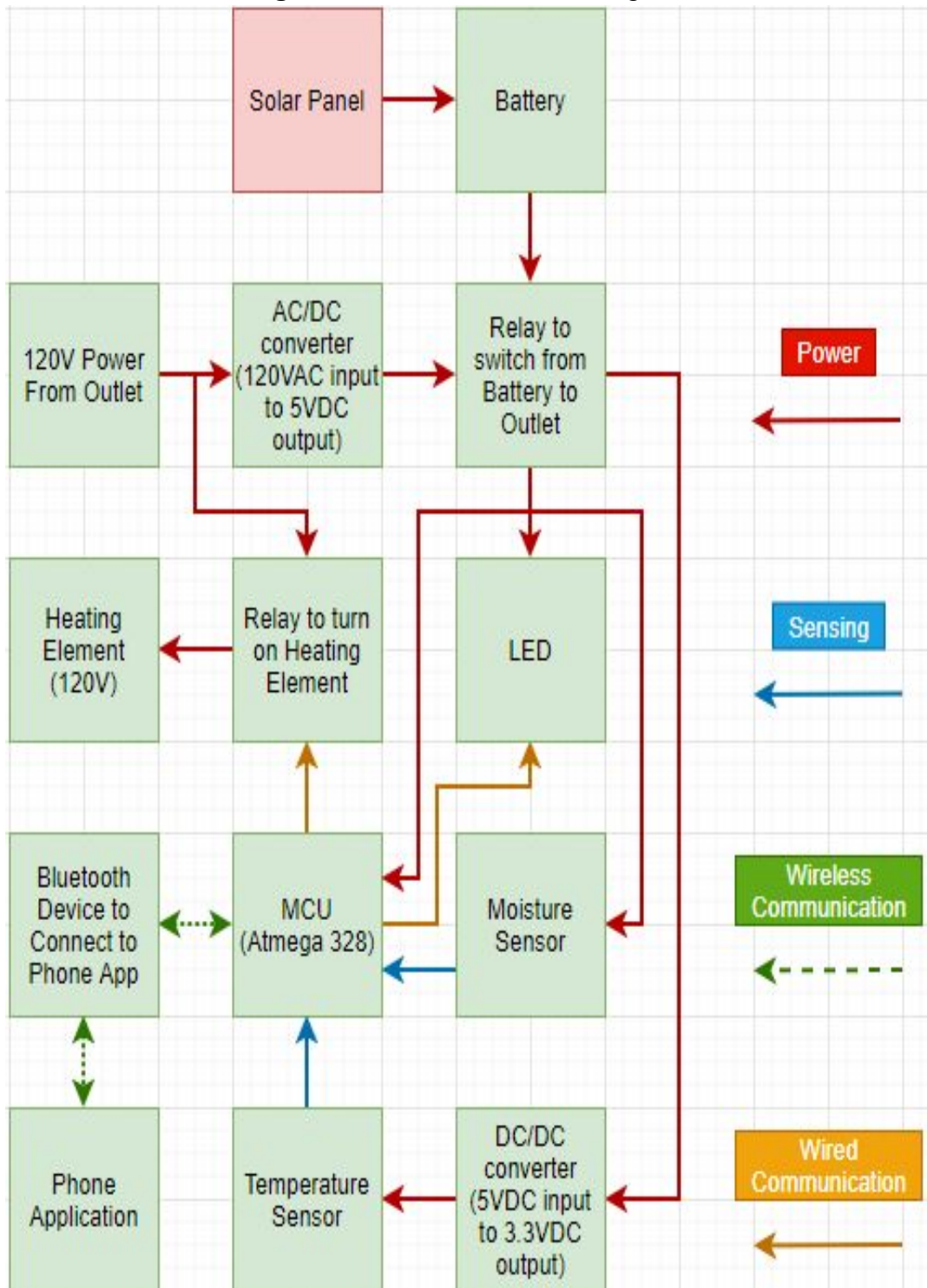

## 2.6.2. Software Block Diagram

**Figure 9** - Software Block Diagram

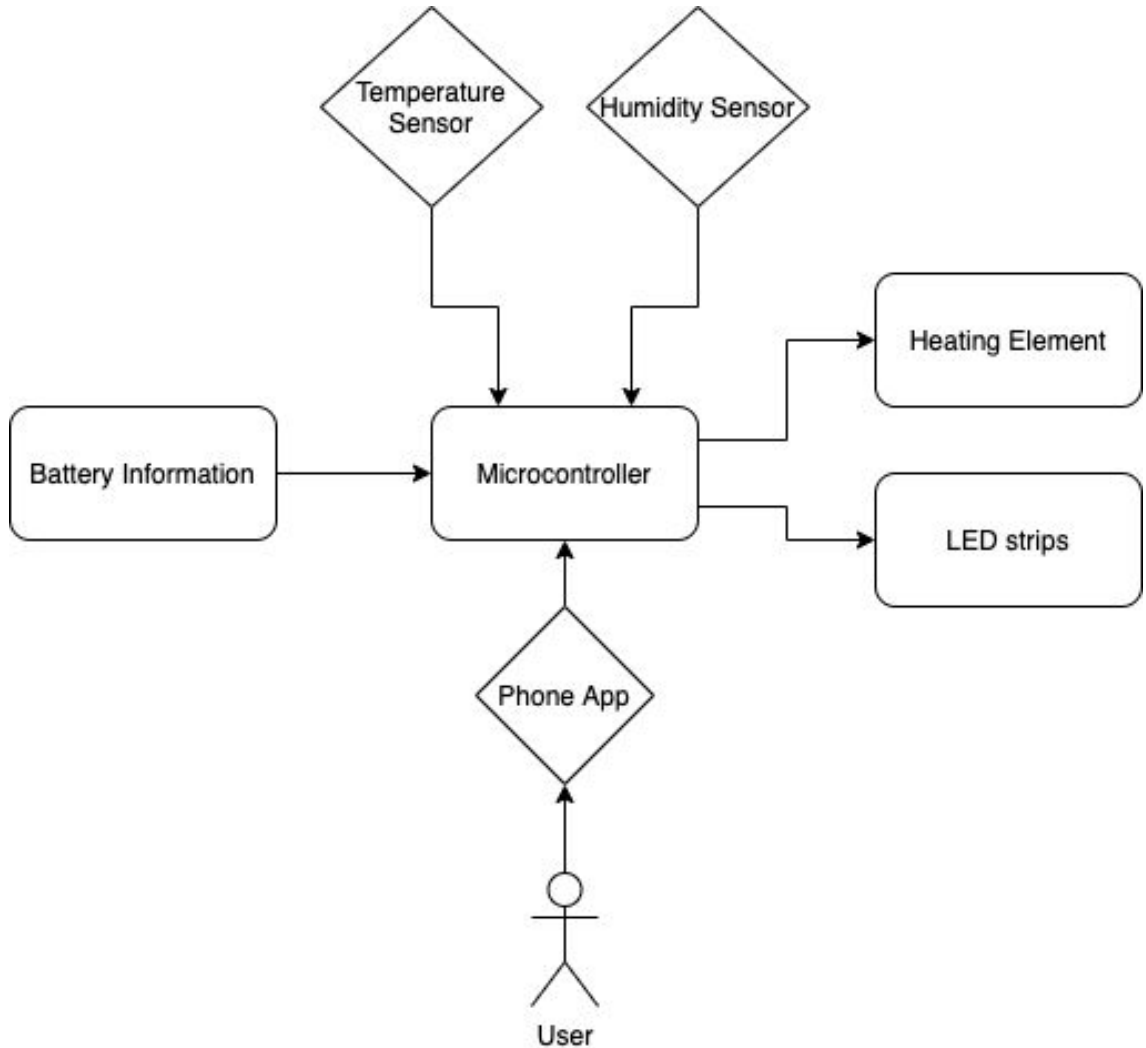

## 2.7 House of Quality

Below is a diagram (Figure x.) of the House of Quality for this project. It outlines our main Engineering Requirements as being Power Efficient, having Accurate Sensors, providing Self-Sustaining Power, Reliability, Product Size, and having a Mobile Application. Together with the Marketing requirements of being Cost Effective, Safe, Durable, Accurate, the Mobile Application being intuitive, and the features associated with the tile system, we were able to determine whether the combination of any two requirements have a strong or weak positive or negative

correlation. This lets us figure out where resource and time strain might appear when designing the system.

**Figure 10** - House of Quality

# House of Quality

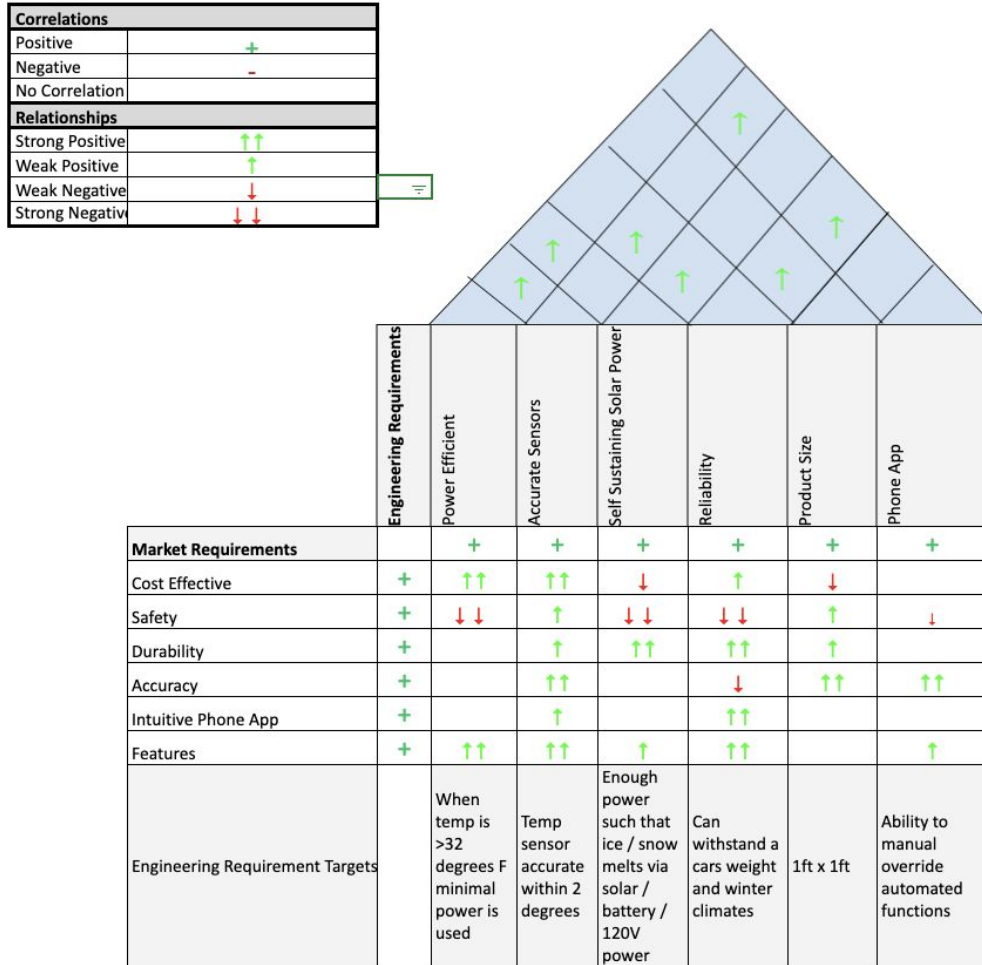

## 3. Research

Research is an integral part of a product design project. There is an old saying that states, “There are many different ways to skin a cat.” That is a great way to explain this. From the start of any project, if 10 engineers work on their own designs, then there will be 10 different designs. Everyone does things differently, but that does not necessarily mean that 1 is right and the rest are wrong. It just means that there are multiple factors.

For the hardware portion of the project, we need to decide what products are best for each subsystem. In this section, we will discuss different options for power, sensors, heating, lighting, and the structure itself. The goal here is to weigh all the pros and cons of each option so that an educated decision can be made on which products should be chosen and which way this will get designed. For instance, is it better to use solar power, batteries, a power outlet, or a combination of the three? Is an electrical heating system best or is a hydronic system better? Which type of temperature and humidity sensors are best for this project? All of those options and more will be discussed in this section.

For the software portion of the project, research into which microcontroller fits our requirements, the best way to communicate with the microcontroller, and how the user interacts with the system as a whole is explored. The microcontroller is the heart of the project as it controls every aspect of the device, so heavy consideration must go into finding the right microcontroller that meets the needs. There are multiple ways to communicate with the microcontroller, so research into each feasible method must be conducted to decide on the most promising one. Each subsection will outline the pros and cons of each communication method and how they would fit within the project.

Another huge software aspect of this project is how a user can interface with the microcontroller and to an extent the entire system through it. Three options come up when planning this type of communication, no application or interface, a web application, or a mobile application. Ideally, the user should have an easy and intuitive experience when setting up and managing their system. The user should also be able to control the system without having to physically interact with it. These considerations are all explored under each sub-section and will weigh heavily in the final determination on which mode of how the user interfaces with the system.

### 3.1 Microcontroller

The Smart Driveway’s microcontroller has a requirement of being able to take inputs and output data from the temperature sensor, humidity sensor, battery, heating element, and LEDs. It also requires that the user be able to communicate

with it wirelessly. The microcontroller must also be compact enough to fit in its own isolated area to prevent water and other potential ambient weather damage.

For these requirements, the Arduino Uno Wi-Fi satisfies the conditions with the fourteen input/output ports and 6 analog ports. The temperature and humidity sensor require the analog ports and the LEDs and heating element will be controlled by the normal input/output ports. It has a port for an AC to DC connection with which the battery within the tile will be connected to. Size of the microcontroller is important since the microcontroller will be seated inside the tile. The dimensions are 3.15 x 2.17 x 0.98 inches, which will fit well within the tile while also giving the rest of the elements that must be within the tile enough room. [20]

To manage communication, WiFi or Bluetooth is necessary since a wired connection to a phone or computer is not reasonable. The Arduino Uno WiFi has both WiFi and the possibility to add a bluetooth module. Communication to the microcontroller is important because control over the heating element and LEDs will not be fully automated.

## **3.2. Communication Considerations**

For communication between the device and the user a remote connection is necessary. Having the user operate the tile system through a wired connection would cause complications in the design of the tile. The multiple ways the smart tile design could incorporate a wireless connection between a phone, computer, or other device that have been considered. The three top contenders for this system and its needs are RFID, Bluetooth, and WiFi. Each method has its own merits and drawbacks, as listed in the subsections below.

### **3.2.1. RFID**

RFID was the initial communication method that was decided upon when coming up with the idea for a smart driveway. The ideal scenario would be that a vehicle would have an RFID chip attached to the underside of the car and the RFID tag would be inside the smart driveway tile. As the car passed over the tile, certain functions within the tile would activate or deactivate based on the sensor data.

In reference to Figure 4 below, low frequency RFID would be a good solution in regards to having the signal given by the reader with its property of material penetration. In terms of whether or not the reader could read from a car's body distance, low frequency RFID does not typically have a range up to the required 1 meter distance. In order to reach that range, the reader would need an amplifier which would increase the cost of the end product and draw more power, reducing the efficiency.

**Figure 11** - Comparison of the different RFID frequencies [21] (Permission Requested)

	LF	HF	UHF	Active
<b>Frequency</b>	125 – 134.2 KHz	13.56 MHz	850 – 960 MHz	100 KHz – 2.45GHz
<b>Range</b>	0.2 – 2m	Up to 1m	Up to 3m	Up to 100m
<b>Cost</b>	Typ. 3 GBP	(Typ. 0.50 GBP)	(Typ. 0.30 GBP)	(Typ. 20 GBP)
<b>Memory</b>	Typ. 64 bits	Typ. 2048 bits	Typ. 96 bits	Typ. 32 bits
<b>Penetration of Materials</b>	V. Good	Good	Poor	V. Good
<b>Data Rate</b>	Slow	Fast	Fast	Fast
<b>Reader Cost</b>	50 – 500 GBP	50 – 3000 GBP	1000- 3000 GBP	200-600 GBP
<b>Read Multiple Tags</b>	Poor	Good	Very Good	Good
<b>Applications</b>	Animal Tags, Vehicle Immobilisers, Industrial Applications	Item Tracking, Access Control, Smart Labels	Box and Pallet tracking Some Item Tracking	Industrial Applications. Asset Tagging Location Systems

Ultrahigh Frequency’s base cost for a reader is orders of magnitude higher than low frequency or high frequency which would drive up the total cost of manufacture and design for the smart tile and make it not marketable. Even though it would be the best option for the distance required, it also is rated to be poor for penetration of materials as shown above in Figure 4, which makes UHF not suitable for a design where it would inherently have to pass through at least pavers, wood, glass, and snow or ice.

High frequency RFID’s range and pricing for a reader makes it the right decision for what the smart driveway tile would try to achieve with a car passing over it and activating certain features. As seen in Figure 4, High frequency’s range, around 1 meter, is about the distance between a vehicle’s body and the ground. Overall, having a high frequency RFID reader is limited with the functionality that could be achieved. In the grand scheme of the smart tile design, the functionality it would serve can be achieved with the other two wireless transmission options. It also is the frequency band that is most affected by metal [21], which could lower the total range of the reader and cause a lack of response from the tile when a car would need to be sensed. This is w A high frequency RFID reader would be a great option for the functionality required of a communication device if the frequency band was not affected so much by the presence of metal. This is typically why high frequency RFID readers are mounted on a structure, unimpeded from any object that could block its path.



## 3.2.2. Bluetooth

Bluetooth could serve as a direct communication method from a mobile or web application or vehicle to the microcontroller. Almost all modern phones and cars have bluetooth technology which allows for ease of access to the tile. With a device connecting the microcontroller through bluetooth, there are two options for managing the functionality.

Option 1 is a binary on-off mode that is toggled by connectivity. If a device connects to the microcontroller through bluetooth the device will turn on the heating element or LEDs, or both depending on the target goals for the smart tile. This limits the overall functionality of the device and the modularity of what it can be capable of. It also inhibits the user's control over the device when the user wants to control it manually by only giving the option of an on-off. Option 2 is a mobile or web application that controls the smart tile when it's connected to the microcontroller through bluetooth. The mobile or web application could give a visual representation of the status of the smart tile. A mobile or web application would allow for better control over the heating element and would enable the LEDs to have more customizable options for their use.

The best user experience for controlling the smart tile would end up being Option 2 where a mobile or web application is involved. It would require more setup than simply toggling the sensor, but the accessibility to the functionality of the smart tile would end up being more marketable. For the Arduino Uno Wi-Fi to have bluetooth capability, it would require an external bluetooth module or a USB bluetooth receiver. With an external bluetooth module, it would occupy 4 of the input/output pins that the temperature and humidity sensors might need to be connected to depending on the hardware. The USB bluetooth receiver would take up the valuable one USB slot on the Arduino Uno Wi-Fi. Depending on how many input/output ports that the sensors take up, the external bluetooth module would likely be the most efficient use of resources on the microcontroller.

Overall, Bluetooth is a solid communication method that gives great accessibility and control over the microcontroller in the smart tile. The main drawback is that the user controlling the device connecting to the microcontroller has to manually pair their device with the microcontroller every time they would want to access the phone or web application's features. Another drawback would be a security concern that anyone nearby could connect to the smart tile. This can be mitigated by having the bluetooth require the mobile or web application type in a PIN or passphrase to be able to change any settings on the smart tile.

### 3.2.3. Wi-Fi

For communication from the microcontroller to a mobile or web application, Wi-Fi may serve as the best means to do so. The microcontroller can be configured to connect to the home network. When the user's device is also connected to the home network they can access the mobile or web application to send and retrieve information from the microcontroller. This may prove to be the most marketable route as well, since most users who would be interested in such a device most likely have other smart home technologies that are connected through their Wi-Fi.

After looking into RFID and Bluetooth Wi-Fi seems to be the most logical method of communication. The Arduino Uno Wi-Fi comes with an integrated ESP8266 Wi-Fi Module. The only issue is that the ESP8266 Wi-Fi Module's range is about 5m. This means that unless the tile is close enough to the router's signal, it may need an external antenna or to act like a hotspot.

**Figure 12** - Block diagram displaying the microcontroller's data path

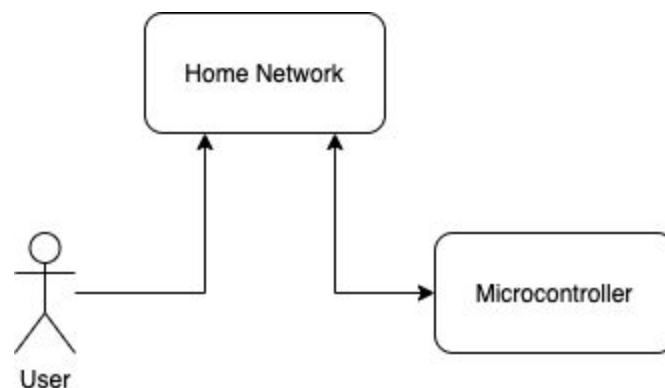

Connecting to the home network would end up being the easiest method for the user to control the features planned for the smart tile. The smart tile would already be on the home Wi-Fi and there would not need to be any extra steps required when initially connecting to the smart tile. Whenever the user's device is connected to their Wi-Fi, the phone or web application would recognize this and allow them to make changes to the status of the LEDs and let them manually turn on or off the heating element.

If the microcontroller does not have enough range or the capability to mount an antenna to extend the range, the Arduino Uno Wi-Fi can use the ESP8266 Wi-Fi Module to act as a Wi-Fi hotspot. This allows the user's device to connect to the microcontroller directly, and in the same way as if the microcontroller was connected directly to the home network, it can read inputs from a mobile or web

application. The main drawback of this is the same as the bluetooth option, where the user would have to disconnect or turn on their Wi-Fi to connect directly to the microcontroller. This is considerably less marketable than if the smart tile were able to connect to the house's network.

### **3.2.4 Microcontroller Communication Conclusions**

In summary, due to the fact that the Arduino Uno Wi-Fi comes with an integrated Wi-Fi module, communicating to a mobile or web application through Wi-Fi would be a much better alternative than RFID or Bluetooth. RFID's base cost and lack of penetration through materials for high frequency RFID makes it unsuitable for this design. Bluetooth suffers from two issues. The first being that it would require extra resources on the microcontroller by using 6 of the input/output ports or using a third party bluetooth USB. The second issue is that the user would have to turn on their bluetooth and pair with the microcontroller every time they want to change the non-automated functionality.

Using Wi-Fi on the microcontroller that is connected to the home's Wi-Fi is the best way for the user to interact with the microcontroller. As long as they are connected to their home Wi-Fi, they can use the phone or web application without having to toggle on or off any other settings.

## **3.3. Application Considerations**

For the smart tile device a mobile or web application needs to be able to control certain functions. Its requirements include viewing battery level, turning on LEDs and changing the LED colors, and manually overriding the automated sensor for heating. The application needs to have an intuitive user interface and be able to communicate reliably to the microcontroller. In the following subsections, the research on the pros and cons of a web application versus a mobile application will be laid out.

### **3.3.1. No Web Application**

If the smart tile system were to not have a mobile or web application, it would rely only on the automated features programmed to the microcontroller. This limits the amount of control the user would have over the system by not allowing them to turn the heating element off when the user would like to leave the snow or ice on the smart tile sections. The user would also not have the option of turning the LEDs on or off. Changing the LED colors by the user would not be an option and the LED strip would have to be controlled only by the inputs from the data sensors.

In short, having just the smart tile with no external method of controlling the features would lower the marketability of the smart tile system. The smart tile would still have all the functionality of heating the snow or ice to its melting point, but the user would not be able to make decisions on when or how the device operates beyond what it has been programmed to do.

### 3.3.2. Web Application

A web application hosted either locally or the internet would be able to satisfy all the requirements. The web application would use the Flask framework which uses Python for the backend and HTML/CSS for the frontend. A database may be needed to keep a log of important temperature, humidity, or user access data.

**Figure 13** - Phone to web app to microcontroller data flow

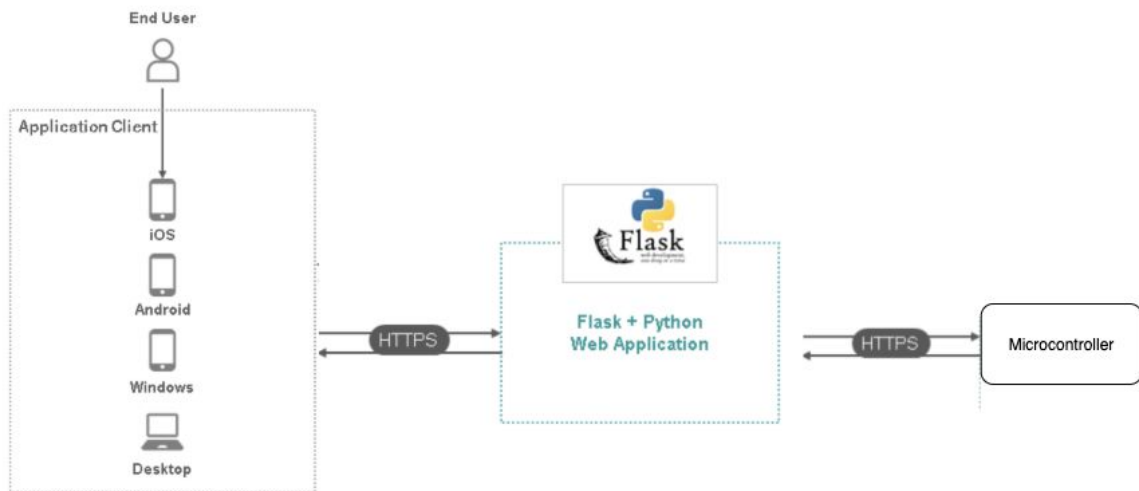

The flow of information would stem from the microcontroller, be sent to the Flask web application over HTTPS using the microcontroller's Wi-Fi, to the end user's device where they would view the data which would be connected to the same network. The Flask web framework can also be utilized as an Application Programming Interface (API) to send and receive data to the device over the Wi-Fi connection. The API would serve as the information intermediary that would tell the device when to turn on the heating and LEDs, what color to change the LEDs to, and request information on battery, temperature, and humidity levels.

For the web app to be hosted online, there would have to be a process of pairing the smart tile system to an account. This could be done by a PIN or code unique to each smart tile system that, once a registered user's account is prompted to

enter their code, the tile system would be then paired after the corresponding code is entered.

The pairing would require extra and possibly unnecessary software engineering hours to add this functionality. It may drive down the marketability of the system due to the added steps of registering an account and the PIN before ever being able to access the interface to alter the system. For this reason, a web app would be less marketable and require more overhead in terms of development hours to make it feasible.

### **3.3.3. Mobile Application**

A mobile application would allow the user to connect directly to the smart tile's microcontroller when the microcontroller is also connected to the home's Wi-Fi. The mobile application would use the Kivy framework, which uses Python as its backend language. Kivy is a cross-platform framework for mobile application development that can be run on both iOS and Android. It also allows for the application to have a native graphical user interface (GUI) without using any other frameworks.

Kivy acts as an all-encompassing solution to writing both the backend and frontend of the mobile application. From Kivy's website, "Kivy is 100% free to use, under an MIT license (starting from 1.7.2) and LGPL 3 for the previous versions. The toolkit is professionally developed, backed and used. You can use it in a commercial product [22]," This allows us to use Kivy in our final product as long as we include their MIT licensing.

Figure 3's diagram shows a very similar layout as to how the mobile application's communication transmission would work. The only difference would be replacing the "Flask + Python Web Application" section with "Kivy + Python Mobile Application." Kivy would replace the need for third party hosting of a web application while also eliminating the need for the user to navigate to a website to log in and pair with the device with a PIN. This simplifies the engineering requirements of having to address each smart tile with a unique passphrase or PIN and reduces the likelihood of a user not being able to pair their smart tile system.

The mobile application would utilize the user's Wi-Fi connection to communicate to the microcontroller which would also be connected to the Wi-Fi through the Arduino Uno ESP8266 Wi-Fi Module. This provides a secure connection that cannot be accessed by anyone who isn't on the network, unlike Bluetooth where anyone near the device would be able to connect without added security measures.

### **3.3.4. Application Conclusions**

In summary, a mobile application provides all the benefits of having an external GUI. This allows the user to have extra management controls over the smart tile system while giving the user an easy to use and intuitive setup process. Having no application would severely limit the user experience and versatility the smart tile system could provide if the user could decide to manually control the features. A web application gives the same amount of control as a mobile application but has a significantly larger overhead to set up and have a secure smart tile to device connection. For this design, a mobile application written in Python using the Kivy framework would be the most efficient and least resource intensive option.

## **3.4. Power Considerations**

In choosing a power source for this project, there are many different power technologies to consider such as Solar power where it has the ability to harness the power of the sun and in turn generate electricity. Battery power which allows portability, quick installation and energy storage if used in combination with the solar power option. Another method to consider is AC Outlet power which allows the consumer to have maintenance free operation, stable and reliable power connection.

### **3.4.1. Solar Power**

The Main use of these Heated tiles will be for melting snow and ice either on a consumers driveway or walkway. This can be done in a green way such as solar power, which will ultimately help the consumer keep down maintenance of the tiles and add the benefit of free energy to keep the cost down. This will work by having external power generation through the panels which will harness the power of the sun and store the generated power into a smaller battery that will either be internal to the tiles, or a larger battery that can be external to the tiles. If using a larger battery with a higher storage capability it allows for a lower cost if using multiple tiles for a driveway or walkway where all the solar power generated can be linked to one battery. The tiles will need to incorporate solar panels to allow this power generation to work. The tiles will charge the battery all day, and when coupled with humidity and a temperature sensor this will allow the power to flow to the heater system when the proper conditions are met. In turn the energy is converted to heat and will melt the snow or ice when the temperature and humidity is within the range we specify. Using Solar energy will be a great benefit for the consumer because it is becoming highly popular and it is currently one of the better eco-friendly choices that offers many benefits to homeowners and businesses. Due to the advantages of saving money, being

robust and helping the environment this option makes it a standard option for the tiles. When Dealing with solar power, many options, disadvantages, and advantages may come along with this type of system. Various panels will vary in performance and ratings. Some types may use different technologies to convert the sun's energy into more useful energy. [23]

### **3.4.1.1. Solar Panel**

Solar panels are becoming more solar efficient and after the initial cost of the solar panel itself they will be completely free to run. Coupled with the fact that they are a green and a renewable energy source. The price for solar panels may be high, but have fallen drastically over the years, but once the initial cost of the solar panels are accounted for the rest would be savings. These solar panel tiles if permanently installed in a driveway or walkway may help consumers' home values, because homes installed with solar panels tend to sell faster and at a higher price than a standard home without. Solar panels on the tiles would be for mainly charging the internal or external battery, supplying the tile with enough power to melt and defrost the ice and snow, so maintenance would need to be almost close to none for the consumer. Generally speaking, solar panels require no solar maintenance once installed. Consumers would generally have to make sure they are kept clean and not shaded, however rain usually helps remove dirt. Solar panels themselves come with a very long lifespan typically 30-40 years. Solar panels are very versatile in ways they work, such that they do not require direct sunlight to work. Although maximum efficiency is reached when in direct sunlight. Electricity will continue to be generated during cold climates, winter and when cloudy. However no electricity will be produced at night, So having a way to store energy such as a battery from the day will be the best route to take for the tiles. There are 2 types of solar panels such as solar thermal panels which absorb the sun's warmth and the Photovoltaic Panels that convert sunlight into electricity. [24]

For the tiles, we chose initially to have a solar panel built into each tile, however careful consideration to cost, functionality and maintenance led us to choose an external solar panel option. This would lead the design of the tiles to be much more simpler. The Tiles should be interlocking in both shape and electrical connection via a bus type system to feed power from the solar panels to the internal batteries of the tiles. Since the solar panel(s) would be mounted externally, typically the roof, the slope of the roof should be 30 degrees for optimum performance. However, this is not a requirement because solar panels are able to operate in many different conditions and settings. It would be best to try to keep them away from shade from trees and other external interferences that can alter performance or scratch and damage the surface of the solar panels.

### **3.4.1.2. Photovoltaic (Solar PV) Panels**

These solar panels are made of solar cells that are electrically connected called photovoltaic cells that convert sunlight into electricity. These cells are silicon semiconductors, when light collides with the surface of the cells, the electrons are then split from their atom and this will generate electricity through the panel. Today's solar cells can convert about 20% of the sunlight into electricity, and commercial solar cells are able to get about 40%. While this may not seem very efficient, in fact Panels are becoming more and more efficient. The very first solar cell was created in the 19th century with solar efficiency of 1%. Solar panels on average reduce carbon dioxide by 35 million tons and save 75 million barrels of oil annually. The amount of energy received from the sun on the Earth in one hour is more energy than the energy the earth consumes in an entire year. Solar cells surprisingly operate better when the climate is cooler, and not hot. They tend to perform better because solar cells harness sunlight and the efficiency of these cells are decreased with higher climate temperature. The Photovoltaic Solar Panel will be the type of solar panel to be used in the project because the tiles will be mainly in effect during the winter time, where it would be hard to extract heat from the sun, but easier to absorb sunlight to generate electricity to store for when needed. [23]

### **3.4.1.3. Solar Thermal Panels**

The Solar Thermal Panel works by absorbing the sun's warmth and heating water from it to keep swimming pools and homes heated. These panels are not as popular as the Photovoltaic (PV) Panels, but they do offer a lot of benefits. One benefit is that Thermal Panels are actually more efficient than Photovoltaic due to the fact that heat carries more energy than sunlight and does not require a process to transform it into electricity. Solar panels in a whole are quite expensive, however the Thermal Panels are cheaper and have a faster payback period than photovoltaic panels. Surprisingly works in colder climates and incorporates an energy storage system. These panels have little to no maintenance. [25]



**Figure 14** - Solar Power System Basics (Permission Requested)

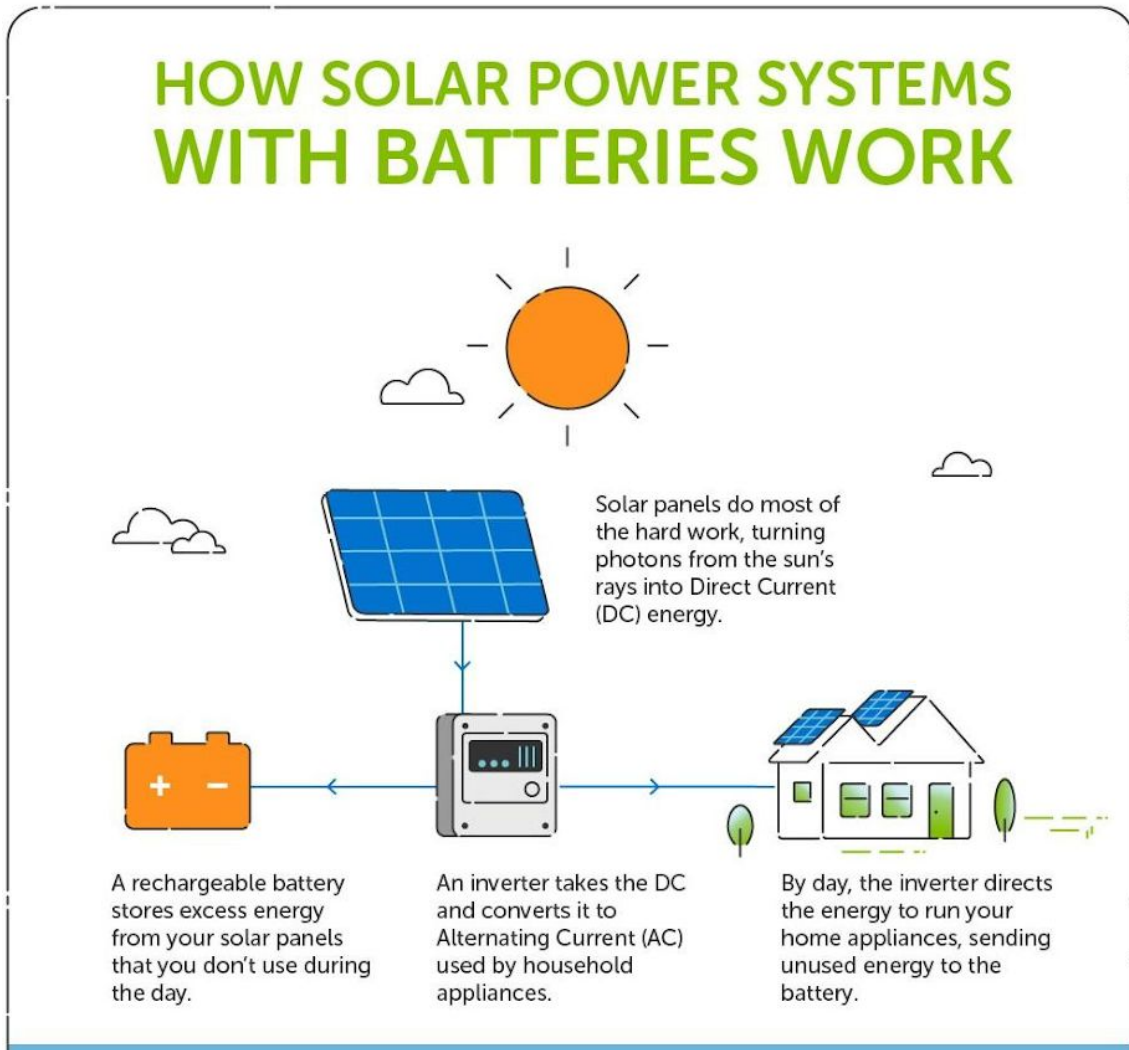

### 3.4.2. Battery Power

There are certain specifications you should use when evaluating your solar battery options, such as how long the solar battery will last or how much power it can provide. The most important ones to use during your evaluation are the battery's capacity & power ratings, depth of discharge (DoD), round-trip efficiency, warranty, and manufacturer. Consumers will ask how long will these tiles be able to run for? There are two ways to answer this question and the first is to determine how long a solar battery can power The Tiles. A fully charged battery should have the tiles work a couple of hours to melt any snow accumulation in the day when energy is being produced or overnight when your solar panels are not producing energy. To make a more exact calculation, a few variables will need to be considered, including how much energy the tiles consume in a given day or scenario, How many tiles will be used at one time,

what the capacity and power rating is for your solar battery and whether or not you are connected to the electric grid. [26]

### **3.4.2.1. Capacity and Power**

The total amount of electricity a solar battery can store is called its capacity, which is measured in kilowatt-hours (kWh). It is possible to increase a solar batteries storage system capacity by “stacking” batteries. An interesting design feature of solar batteries includes the capability of becoming “stackable”, which allows its capacity to increase by having multiple batteries in your solar-plus-storage system. If we want to allow the tiles to be more electrically independent, it would be best to have multiple or a very large battery with enough storage energy for a long duration of snowfall. While capacity can display the amount of electricity stored, it doesn’t exhibit the amount of electricity a battery can discharge at a given moment. To fully understand, you’ll need to keep in mind the battery’s power rating. When speaking of solar batteries, power ratings are measured in kilowatts (kW), and is defined as the amount of electricity the battery can discharge at one time. The tiles would need a battery that is able to deliver power over a long duration of time, it is not necessary to have instant power, but would be better to have enough power to keep the temperature high enough to melt snow. Keeping this concept in mind, a battery with a large capacity but low power rating could in theory power a few essential devices for an extended time. On the other hand, a battery with low capacity but a high power-rating could potentially power your entire home, but only for a few hours. [27]

### **3.4.2.2. Depth of discharge (DoD)**

An important requirement of solar batteries and many other types of batteries is that they need to continually retain charge due to their chemical composition. If a battery is drained completely, its usefulness will be shortened significantly. Knowing this will help with the design of the tiles. We will be able to incorporate a mode in our device when the battery level gets down to a certain threshold. We will either switch the device off to protect the battery life longevity, or we will use either a combination of circuitry to route power from another source. Doing this the tiles will have more functionality and will be a more versatile and robust accessories for homeowners. The amount of capacity that has been drained from a battery is termed the depth of discharge (DoD). Usually, a maximum DoD will be specified by the manufacturer for optimal performance. For example, if the battery had a capacity of 10 kWh and has a DoD of 90%, then there would be adverse results if more than 9 kWh was used before recharging. More often than not, a higher DoD is directly associated with the ability to utilize more of a battery’s capacity. The Tiles should be able to utilize a high depth of discharge to be able to use the max amount of energy in the battery before switching to

another power supply. This will allow the Tiles to utilize the max amount and save energy, while getting the most out of the rechargeable battery. [27]

### **3.4.2.3. Round-Trip Efficiency**

Choosing the right battery for the tiles we would need to consider the batteries Round-trip efficiency. This describes the volume of energy by a percentage of the amount of energy that is used to collect it. Since the Tiles will incorporate Solar Power Panels to charge these batteries, it is expected to be as energy efficient as possible and doing this we need our battery round trip efficiency to be as high as possible while keeping cost down. For example, if the battery intakes and stores a capacity 5 kWh of electricity, but only outputs 4 kWh of electricity, the battery has a 80% round-trip efficiency ( $4 \text{ kWh} / 5 \text{ kWh} = 80\%$ ). Generally speaking, the higher the round-trip efficiency is on a battery, the better economic value you will receive. To find the right batteries, we will need to know the full power draw of the tiles, with the Heating system, sensors and LED's. Then we can find a size limit, and different manufacturers specifications to best suit the Tiles. [27]

### **3.4.2.4. Battery Life, Warranty & Manufacturers**

Choosing the correct batteries for the Tiles will be so that it will offer all the power performance and user functionality that is expected. Batteries tend to “cycle” or charge and drain daily when used in home energy storage settings. The battery's ability to maintain a charge will eventually decrease with consistent usage. In this way, it's easy to compare solar batteries and cell phone batteries, because they both eventually wear down over the years, and will not retain its original capacity. Over a long period of time we expect the battery to lose performance, and in doing so we want to be able to choose the best battery for this application. One, where the battery is reputable, and offers peace of mind. Consumers should know that the batteries will have warranty from defects, external or internal. Two, consumers are under peace of mind that the battery will perform and meet battery life expected from the data sheets of the battery. For example, some batteries might be warrantied for an x amount of cycles, or x amount of years at a certain percentage of its original capacity. If the percentage for capacity should be 70%, then that means after x amount of years or cycles, the battery will have lost no more than 30% of its original ability to retain energy. Solar batteries are produced with warranties in place that will guarantee a certain number of cycles or years of useful life. Naturally, battery performance degrades over time, so most manufacturers will also guarantee a certain capacity over the extent of the warranty. Many diverse kinds of companies are expanding and producing solar battery products, from automotive corporations to new startup tech companies. [27]

At first, we were deciding to go with an automotive battery because of the robustness of the Lead-Acid 12 Volt system. While all batteries perform worse in cold climates, especially freezing, this battery might be able to withstand the elements a little better due to vehicles consistently being able to start in temperatures below freezing. Given that the battery is in good shape and not an old battery. However, the size of the battery might lead us to have this battery remotely located inside the home, or garage. This can ensure that the temperature of the battery is higher than it would be in the outside temperature. While an influential automotive corporation joining the energy storage market likely has a better influence on battery sales and consumer influence with a long history of battery manufacturing, they may not give the most innovative technology. Taking this into consideration, more research into a perfect battery can be sought after. On the other hand, a tech startup might have something revolutionary, new, and high performing technology. However, this will need to be tested and evaluated to meet specifications. Many times they might not meet the extended period of performance we need. This is where the warranty and overall battery life play a big function in selecting the right battery for the tiles. [27]

The overall span for a solar battery's serviceable lifespan is within 5 and 15 years. Solar batteries installed today will need to be replaced at least once to match the 25-30 year serviceable lifespan of solar panels themselves, making this a very convenient option. The good news is, solar panels have increased the lifespan significantly over the years. Likewise just as solar panel's lifespan has been increased throughout the past decade, it is anticipated that solar batteries will gain better technological advances and allow up to 25-30 years of serviceable lifespan to match. The Tiles will be using batteries mainly for the winter, and not all year long. This will help by allowing battery life to be increased due to less chemical reactions internally throughout the year. [27]

The Tiles will need to be as low maintenance as possible for ease of use and for consumer satisfaction. Therefore, preventative maintenance can be used to increase Solar batteries' life. Batteries, in general, are significantly affected by temperature, thus protecting the battery from freezing or scorching temperatures will extend the serviceable life. When a battery falls under 30° F, it will demand a larger voltage to reach the maximum charge. Likewise, when a battery rises above 90° F it can overheat and cause the voltage requirements to change. Keeping this in mind for the design of the Tile will lead us to incorporate the battery to a remote, sheltered location. For example, the garage or inside the home in its own space where all connections are to be made from solar panels, all the tiles, and the home outlets. These connections should be bundled into one conduit to limit cost and ease of use for the consumers.

### **3.4.3. Battery Types**

To narrow down the battery used for the Tiles, we need to consider the different types of batteries that are currently in mass production. For example, one type of battery may be intended for small size and long runtimes, such as a little cell battery you may find in remote controls or a keyfob. These batteries are small and can last anywhere up to 5-10 years. However for the application, they are in, the battery does not need to supply a large amount of current. When the battery does need to supply current it will do so for a short period of time for our Tile a small battery may not last and will lose power too quickly. Another example may be a battery that is built for long life, however, the exterior size may be a challenge for many consumers. It is not a common thing to just have a battery lying around in your home, especially something that is too big and bulky. There may be a battery that presents all the acceptable qualities, though the expense would be too costly for retail use. [28]

#### **3.4.3.1. Lead Acid Batteries**

Lead-acid batteries are tried and tested within many applications, mainly for the automotive industry. This type of battery would be perfect for the Tile application, however, it may be too big, heavy, and bulky. This type of battery has been used for many off-grid energy systems for years. Even though the lead-acid battery has a relatively short life and lower Depth of discharge than another battery type, Lead Acid is one of the least costly options currently hitting the market in the off-grid energy storage. Having these batteries for the Tiles can be a great benefit because expanding the system can be very simple by adding extra batteries. This can allow consumers to go off the grid even easier because of storage capability. The Lead Acid Battery will be a very good choice for the tiles and most economical for larger power applications where weight is of little concern. [28]

#### **3.4.3.2. Lithium Ion Batteries**

Another type of battery application is the lithium-ion cell battery, the vast majority of modern home renewable power storage exercises some class of lithium-ion. A major difference right off the bat is Lithium-ion batteries are much more compact in size and weight than the previously mentioned lead-acid batteries. Diving into the lithium-ion battery itself shows that from manufacturing specifications they too have a greater depth of discharge than a traditional lead-acid battery. The lifespan of the Lithium-ion is also longer when compared to lead-acid batteries. However, lithium-ion batteries are much more costly, the smaller size and power output make it a more expensive feature for the Tiles than using the lead-acid

equivalents. Lithium-ion batteries are mainly used where applications require batteries to be lightweight and be able to have very high energy density. The Lithium-Ion Battery will be the choice battery for the tiles if they incorporate an internal battery, however, choosing an internal battery will require more current and voltage draw in the cold weather (below freezing). This will make the Tiles not as efficient as we would like. It is also possible to have Lithium-ion batteries remotely inside and route power the same way we would with a traditional Lead-Acid battery. However, going this route is much more expensive and will be more costly than using the Lead-Acid Battery. On the other hand, it could benefit many homeowners by performing exceptionally well and saving room due to the smaller footprint, stacking and expanding Lithium-ion batteries will be easier. [28]

### **3.4.3.3. Nickel Cadmium (NiCd)**

The type of battery is used where long life, high discharge rate, and economical cost are significant. These batteries do not really suit the Tiles performance and will not be enough power. Mainly used in camera equipment, radio transmitters, and some power tools. The NiCd contains toxic metals and is environmentally unfriendly. This type of battery will not be used with the tiles. While NiCd is a good storage option and performs well, they mainly are not as powerful as newer and modern batteries. Also, over time they tend to self-discharge and will need to be recharged, however, that might not be a problem due to constant charging from solar panel energy. [28]

### **3.4.3.4. Nickel Metal Hydride (NiMH)**

Nickel Metal Hydride produces a greater energy density compared to the Nickel Cadmium previously mentioned at the cost of the decreased life cycle. Nickel Metal Hydride holds no toxic elements. Applications include mobile phones and laptop computers. The Tiles will not incorporate these types of batteries because of the short life cycle. [28]

### **3.4.3.5. Reusable Alkaline Battery**

When examining reusable alkaline, it is good to understand that the initial energy of a reusable alkaline battery is slightly less than a standard alkaline battery. However, the Tiles would need to use a rechargeable type of battery so a standard alkaline battery will not work for the Tiles. Using the rechargeable type will also lead to each succeeding recharge/charge cycle to cause the capacity to decrease. While this battery in general may not be the best for the Tiles due to the power performance, they do offer a lot of benefits such as a very low self-discharge. Alkaline batteries are capable of holding a charge for up to 10 years, they are maintenance-free and environmentally friendly. [28], [29]

**Figure 15 - Alkaline Battery Specifications (Permission Requested)**

Specifications	Lead Acid	NiCd	NiMH	Li-ion <sup>1</sup>		
				Cobalt	Manganese	Phosphate
Specific energy (Wh/kg)	30–50	45–80	60–120	150–250	100–150	90–120
Internal resistance	Very Low	Very low	Low	Moderate	Low	Very low
Cycle life <sup>2</sup> (80% DoD)	200–300	1,000 <sup>3</sup>	300–500 <sup>3</sup>	500–1,000	500–1,000	1,000–2,000
Charge time <sup>4</sup>	8–16h	1–2h	2–4h	2–4h	1–2h	1–2h
Overcharge tolerance	High	Moderate	Low	Low. No trickle charge		
Self-discharge/month (room temp)	5%	20% <sup>5</sup>	30% <sup>5</sup>	<5% Protection circuit consumes 3%/month		
Cell voltage (nominal)	2V	1.2V <sup>6</sup>	1.2V <sup>6</sup>	3.6V <sup>7</sup>	3.7V <sup>7</sup>	3.2–3.3V
Charge cutoff voltage (V/cell)	2.40 Float 2.25	Full charge detection by voltage signature		4.20 typical Some go to higher V		3.60
Discharge cutoff voltage (V/cell, 1C)	1.75V	1.00V		2.50–3.00V		2.50V
Peak load current Best result	5C <sup>8</sup> 0.2C	20C 1C	5C 0.5C	2C <1C	>30C <10C	>30C <10C
Charge temperature	–20 to 50°C (–4 to 122°F)	0 to 45°C (32 to 113°F)		0 to 45°C <sup>9</sup> (32 to 113°F)		
Discharge temperature	–20 to 50°C (–4 to 122°F)	–20 to 65°C (–4 to 149°F)		–20 to 60°C (–4 to 140°F)		
Maintenance requirement	3–6 months <sup>10</sup> (topping chg.)	Full discharge every 90 days when in full use		Maintenance-free		
Safety requirements	Thermally stable	Thermally stable, fuse protection		Protection circuit mandatory <sup>11</sup>		
In use since	Late 1800s	1950	1990	1991	1996	1999
Toxicity	Very high	Very high	Low	Low		
Coulombic efficiency <sup>12</sup>	~90%	~70% slow charge ~90% fast charge		99%		
Cost	Low	Moderate		High <sup>13</sup>		

### 3.4.4. Power Outlet

For better functionality, the Tiles will need to incorporate another power source such as electricity from the home outlet. It would be wise to incorporate this

feature because if by chance there is not enough sunlight to charge the battery, the battery will run out of power and snow accumulation will occur. To fix this issue we can introduce a way to connect a home outlet power source to the Tiles. Doing so, the Tiles can integrate a 120V outlet to power the heating, Led, and various sensors to keep the driveway/walkway clear of any snow and ice.

The goal would be to have the Solar panel and battery setup as the primary source of power, where the solar panels will charge up the batteries during the sunlight hours of the day. When snow would fall and the temperature and humidity sensors detect the suitable data of snowfall the heating pad will turn on, getting the power from the solar batteries. While this is a good idea on its own, we recommend adding the additional power supply, such that when battery depletion occurs we can switch over to a constant power supply, allowing the battery to recharge while snow melting still occurs. Implementing this idea will solve the issue of any snow accumulation that could have happened due to power shortages.

Let us start from the Battery source, now, for example, we were to use a Lead-Acid battery (12V system) and that will be charged via solar power panels. We can also expand the storage capacity of the system by adding more 12V Lead-Acid batteries in parallel. This will keep the voltage level the same but increase the overall capacity of the system. It will take longer to charge but gives you more power over a longer period of time which is what we need when it comes to melting snow. Once the battery level gets to a fully charged level, Looking at the manufacturer's specifications of the battery, for this example, let's say 12.66 V. We can monitor this with the Microcontroller's Analog to Digital converter feature. This voltage will be replicated between a number from 0-1023 for the 10 bit Analog to Digital converter. Likewise, the Microcontroller can monitor when the battery falls to a depleted range using the same Analog to Digital converter. For this example, we can say from the manufacturer's specifications the depleted range voltage of the battery is 11 V. The microcontroller itself does not allow an input of no more than 5V, we must be able to downgrade the higher voltage to be able to read it, we can do so in many ways such as a wheatstone bridge, or a step down transformer. Once the voltage is low enough we can set this to be more functional, the Microcontroller will set a ratio from the range of 11 to 12.66 V (now 0 to 5 V) to the Analog Digital converter of 0-1023. This can be very helpful in finding the right time to control the voltage.

Continuing, the battery will start fully charged and will be connected to Tile supplying it 12V of power. This will continue until the battery becomes depleted and reaches a value of 11 V. Keep in mind that snow often time falls even when sunlight is still present, which means while the snow is falling the energy from the sunlight will recharge the batteries while energy is being used to melt snow. This can help make the system more efficient. However, when the battery becomes



close to depleted, the Microcontroller will sense the voltage is too low and will begin to control the power supply change. This can be a very simple design and there are many ways to go about it as mentioned above. When the voltage gets to a certain threshold, the microcontroller will supply a 5 volt signal to control a relay. When this relay senses 5 volts it will ground itself using the ground pin on the microcontroller. This procedure will activate an internal magnetic solenoid which will switch the normally closed pin to the normally open pin of the relay. To further dive into this connection, we use a connection where we open the power wire from the 120V source and run it into the main switching contact of the relay, and from the normally open contact pin, we can connect that to our AC to DC step down inverter to power the Tile with the correct voltage. The next two figures show an in depth view and an overall view of the system using relays and an outlet power source.

**Figure 16** - Diagram of Power Outlet Connection

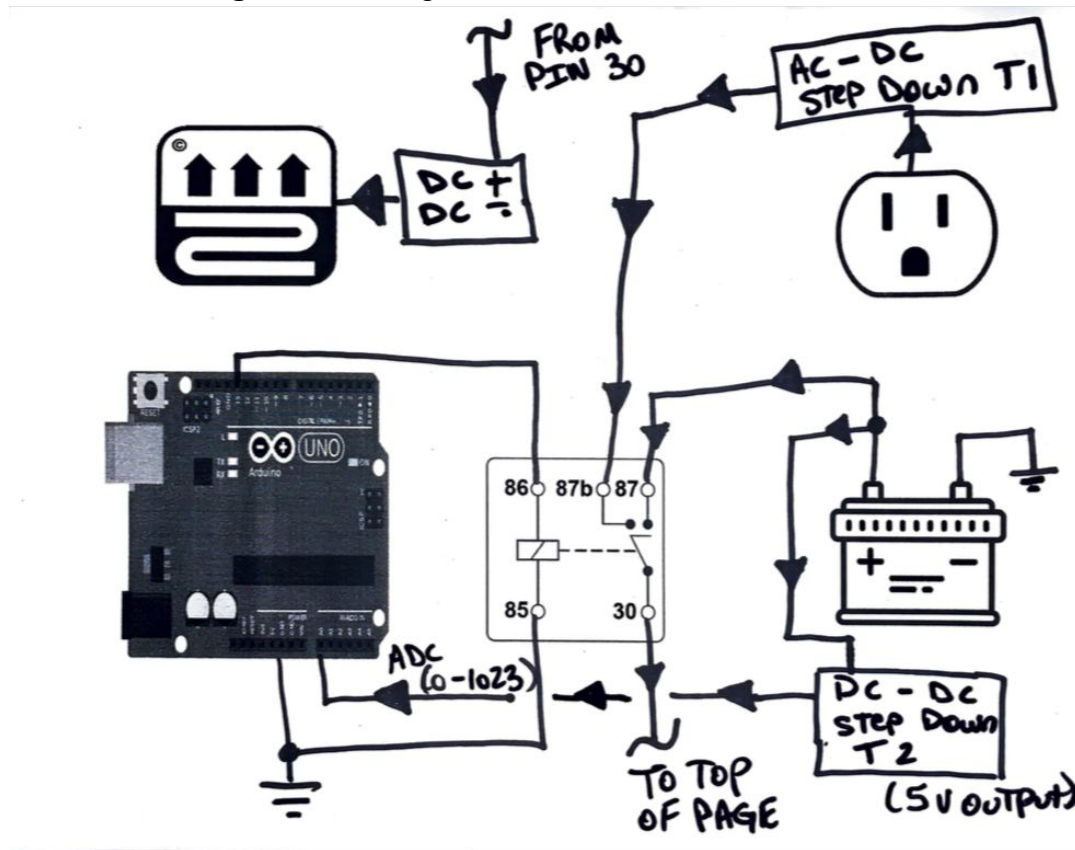

### 3.4.5 Heating System Power

The main purpose of creating the Smart Tile system is to melt snow and ice that may accumulate over a surface. This will be done by using a power source, to transfer electrical power to a heating element internal to the smart tiles. In turn, the Tiles will generate heat internally and radiate this heat to the surface where it

will increase the temperature of whatever is on top of the Tile. If we can achieve a temperature of greater than freezing we can theoretically melt snow and ice that accumulate. Currently, in the research, there is a concern that the heating element that is going to be implemented will have a high power draw that will be too large for the solar panel and battery system to maintain for a long period of time. Therefore, it was not long before we decided to implement more than a single source of power. The additional power source we will implement is the home outlet, where it will allow a reliable power source. The research will be conducted to discover which heating system will be used.

### **3.4.5.1 Heating System Power Pros**

There are many pros when it comes to adding this heating system and powering it correctly. The first thing we want these Tiles to incorporate is safety, efficiency, and ease of use via automation. The Tiles at the main core will be used to melt snow and ice accumulation, while this may be easy to achieve by heating an element, we want it to also be safe for everyone to use at all times. Snow usually can fall anytime during the day and night, so having the tiles operate during both periods optimally is a top priority. Being able to walk on these Tiles should be just as easy as walking on regular pavement, and since adding snow and ice to any surface creates a hazardous situation we want to ensure that the melted snow will not increase hazards, such as slip and fall. So having a proper and efficient heating system to remove snow is required. Now pairing this with a great structural design that allows for maximum heat transfer from our heating element and a sturdy ground to walk on, which will reduce slip and fall, the Tiles can easily replace an entire driveway with great benefits.

The Heating system in the Tiles will also allow for better efficiency for other functions of the Tiles, such as the incorporated LEDs. If the snow and ice build-up is too much, the LED function will be rendered useless because it would be impossible to see through the snow, and would alter the vision of the users. Having this Heating element will allow for Snow melting and a clear visual of the Tiles and LEDs. The LED's will mainly incorporate the use of the battery power source, and the heating element will incorporate the use of the AC wall outlet power source. Some other benefits to having this heating system powered by the wall outlet will be that it will be a very reliable connection. If the solar power battery source is depleted the device can use AC power to help in the regeneration of the battery and help keep the system running by converting 120V AC down to the regulated DC voltage to power all the sensors, LEDs, and all integrated circuits needed. This will allow automation to continue to work. This will also eliminate any power concerns that using just only a battery can bring.

The Smart Tile system will incorporate a 2 type power source system, where it gives the user the most energy-efficient option to choose from, and by doing this

autonomously. Like previously mentioned, the battery power source will be self-sufficient and will power the LEDs, sensors, and all small voltage signals and circuits. Since the HEating element will need a large voltage supply, we will incorporate another power source from the user home and this will allow a more reliable energy connection. Choosing this design will allow the user to be able to set manually the period to heat the element. For example, if a user will be leaving home early and is not sure that snow will fall overnight, the user can set a period for the tiles to turn on just in case it does snow the ground will be warm enough to melt snow, allowing the user to safely travel to his or her car. Also, this will be a function that can be done autonomously. The sensors incorporated will have to reach a certain criterion to allow the power to be switched over to the mains power supply to allow the heating element to turn on and melt snow.

### **3.4.5.2 Heating System Power Cons**

From reviewing the project itself, the main con would be a major part of the actual project, which is the heating element itself. The heating element uses the most power, and can either make or break the project in general. Initially, the Tiles were to be powered by only solar power, however after diving into the process and energy needed to heat an object up even 1 degree we assumed solar panels would not be very effective and a large initial cost. Choosing the right heating element would play a major part in efficiency. We would need a heating element that is strong enough to raise the temperature quickly and maintain that temperature at a safe state. [30]

The most challenging thing to consider would be to maintain constant voltage and current to keep a Tile under and above a certain threshold temperature. At its minimum we would need enough power to raise snow 1 degree above freezing. One method to incorporate is to have the system automatically turn on when the outside temperature drops below 32 degrees Fahrenheit, this will prevent any ice and snow accumulation that may happen. However there are many times where temperatures get below freezing and there is no snowfall. This can pose a problem where the heating element will turn on and will just be wasting energy because there is no snow to melt. The humidity sensor will be incorporated to mend this, by allowing a certain condition in the air to be met, and with the right temperature we can automate the heating element to turn on correctly. Now there is another problem that we might face when choosing the materials to use, because the heat capacity of Ice, snow and water is very high. So using a material that can absorb heat and transferring heat will be very useful in the design. Looking at the Figure 17 below, we can see some properties of different materials and the Heat capacity that they have.

**Figure 17** - The unit kcal (kilocalorie) is a unit of energy. 1 kcal = 4186 J, In units of kcal/(kg°C) the specific heat of water is 1.

Material	Specific Heat = (Kcal/Kg°C)
Water	1.0
Ice	0.49
Steam	0.48
Aluminum	0.215
Steel	0.11
Copper	0.092

We can see that water and ice itself has a very high Specific Heat capacity, using a simple equation to calculate specific heat capacity:  $c = \Delta Q / (m\Delta T)$ . Which means that the specific heat capacity is the amount of energy it takes to raise the temperature of one kg of a material by 1 degree Celsius. We can see by looking at this chart that raising water, or even ice will require a lot of energy. When designing and building our Tile, we need to use the best materials that can transfer heat with minimal heat loss in the wrong areas. Something like copper and steel will work great for being a top layer on the Tiles where we can do what is from underneath and allow heat to travel over the surface to heat the top layer of ice or snow. However, there might be a safety issue that can cause the surface to become very slippery when wet. More research will have to be done to determine how to transfer the heat internally through the Tiles material and safety melting ice and snow to allow no restrictions with safety. [30]

### 3.5. Sensors

Choosing which type of sensors to use can be a difficult task, in this section each different type of sensor that is applicable to this project is discussed and the pros and cons of each type are weighed and compared. There are three different kinds of temperature sensors that are applicable to this project, the Resistance temperature detector (RTD), thermistors and thermocouple. There are three main types of humidity sensors, thermal, capacitive and resistive.

### **3.5.1. Resistance Temperature Detector (RTD) Sensors**

Resistance Temperature Detectors or resistance thermometers are a temperature measuring sensor that are capable of measuring resistance based on the changing temperature of a metal. These sensors typically consist of an RTD element made out of metal and some insulated wires. Power is applied to the wires of the sensor which will increase the temperature of the RTD element, when the temperature of the RTD element increases the resistance of the RTD will also increase. In order to calibrate RTD sensors it is important to know what the resistance value is at 0 degrees Celsius, the most common calibration for these types of sensors are 0 degrees Celsius is 100 ohms of resistance.

The RTD element for high accuracy temperature detectors is typically made out of platinum, but can also be made out of nickel, copper, tungsten, iridium or balco an iron- nickel alloy. For this project's application platinum would be the best option to choose for this sensor. There are a lot of positive factors related to the use of platinum, there is a linear relationship between temperature and resistance, the temperature coefficient of resistance (TCR) is big enough to provide a vast range of measurable resistance readings with temperature change, and platinum provides stability to the sensor because its temperature resistance does not change much over time.

When choosing an RTD sensor it is important to understand the configuration of the RTD element. There are three main configurations for the RTD element, thin film RTD, wire wound RTD, and another configuration where a small coil of wire is inserted into a hole in a ceramic insulator and attached along one side of that hole. The thin film technology RTD is the best choice of these three because it is the most rugged, and most accurate.

There are also different wire configurations to take into account when choosing an RTD sensor, the wires that attach to the RTD element are typically made out of copper since platinum wire would be too expensive to produce. The copper wires that connect to the RTD element have a resistance that can affect the accuracy of the sensor, this resistance is known as lead resistance and must be taken into account. When choosing a wire configuration there are two wire RTDs, three wire RTDs and four wire RTDs. A two wire RTD is the least accurate RTD and should only be used for approximating temperature values, three wire RTDs are the most commonly used RTDs because the lead resistance can be compensated for with a Wheatstone bridge circuit. The problem with three wire RTDs is the length of two of the wires has to be roughly the same in order for the

Wheatstone bridge circuit to work effectively. Figure 8 below shows a three wire RTD circuit with a Wheatstone bridge configuration.

**Figure 18** - Three Wire RTD Circuit with Wheatstone Bridge

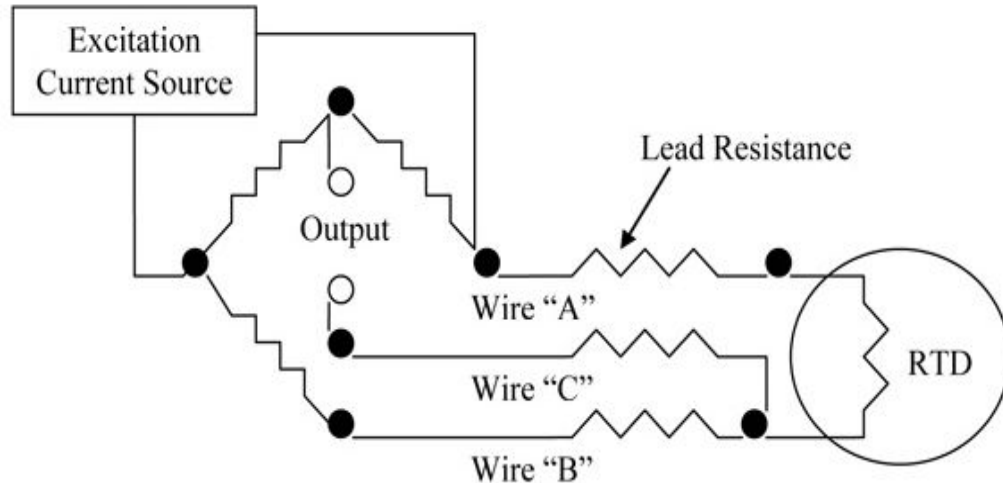

In a four wire RTD configuration the length of the wires does not matter, because instead of a Wheatstone bridge circuit, a current source, reference resistor and digital voltmeter are used. If available a four wire RTD is the best option because it is capable of completely compensating for the lead resistances and providing the most accurate temperature measurement at a low cost.

Some of the main advantages of an RTD sensor are high accuracy, stability, linearity and little to no susceptibility or electrical noise. RTD sensors can be accurate within up to 0.1 of a degree and have a wide temperature range from -200 degrees Celsius to 650 degrees Celsius. Some of the disadvantages to an RTD sensor are error due to lead resistance depending on the configuration, vibration resistance, the size of the sensor and the response time. RTD temperature sensors can have a response time from 1 second up to 50 seconds to get an accurate reading. Unless a thin film technology RTD sensor is used, typically RTD sensors are a large component and would not be ideal for projects with size constraints. [31]

### 3.5.2. Thermistors

Similar to the RTD sensor a Thermistor is another type of temperature sensor that relates the change in resistance to temperature. The main difference between a RTD sensor and a Thermistor is that a Thermistor is not just pure metal, it is made with semiconductor materials, metals and metal oxides. These materials are pressed into a bead, disk or cylinder and then an impermeable material is coated on top such as glass or epoxy. In order to operate a thermistor

a constant current must be passed through it and its voltage can be realized, when current and voltage are known the value for resistance can also be realized and related to temperature based on a data sheet.

When choosing a thermistor there are a lot of factors that should be taken into account one of the main factors is the placement of the thermistor in the system. Thermistors come in a variety of shapes and sizes and can be placed remotely, directly embedded in the surface or submerged in liquid. If setup in a remote location away from the surface, the accuracy and stability will decrease significantly due to thermal lag time. In order to achieve the best accuracy and stability out of a thermistor the thermistor needs to be placed as close as possible to the surface that needs temperature control. For the most accurate temperature control the thermistor would be embedded directly into the surface that needs temperature control.

There are two ways a thermistor can operate, a positive temperature coefficient (PTC) or negative temperature coefficient (NTC). The PTC thermistor operates similarly to an RTD sensor, when the temperature increases the resistance also increases and the NTC thermistor operates by decreasing resistance when the temperature increases. In most temperature sensor applications of this sensor the NTC configuration is used, the PTC configuration is often used as a fuse.

Unlike the RTD sensor a thermistor is non-linear, the output of resistance vs temperature produces a curve and it must be linearized. Each thermistor has a different curve, some materials can produce a more stable curve than others. The stability of a thermistor's element is stable and will not be affected much by age.

One of the greatest advantages for thermistors is the sensitivity and accuracy, this type of sensor is able to measure very small changes to temperature. Thermistors work well when they are used in a system that needs to maintain temperatures or trigger a heating or cooling system with a temperature controller. Some of the disadvantages include a narrow temperature range and self-heating that takes place because of constant current. [32]

### **3.5.3. Thermocouples**

The Thermocouple is the simplest temperature sensor available. The thermocouple consists of two insulated wires with exposed ends. The end of each wire is joined with a solder or weld creating a junction, the wires are then twisted together, to cancel out any noise. Each of these conductors are made up of different metals and have different thermal conductive properties. Due to the thermal-electric effect a thermocouple can produce a temperature dependent voltage.

There are different types of thermocouples depending on the application. The most common types of thermocouple are K-type, J-type, T-type, E-type, N-type, S-type, R-type and B-type. When considering these types of thermocouples, it is important to keep in mind this sensor will control the heating system and must be very accurate and able to operate over the range necessary to maintain specified temperatures. Another thing to keep in mind when considering a thermocouple is the lifespan of a thermocouple. Figure 10 compares the temperature range, accuracy, material, and cost of each type of thermocouple.

**Figure 19** - Thermocouple Table Comparison Table

Type	Temperature Range (Degrees F)	Accuracy	Metal (Wire1/Wire2)	Cost
K	-454-2300	+/-2.2C	Nickel-Chromium/Nickel-Alumel	Low
J	-346-1400	+/-2.2C	Iron/Constantan	Low
T	-454-700	+/-1.0C	Copper/Constantan	Moderate
E	-454-1600	+/-1.7C	Nickel-Chromium/Constantan	Moderate
N	-454-2300	+/-2.2C	Nicrosil/Nisil	Moderate
S	-58-2700	+/-1.5C	Platinum-Rhodium/Platinum	High
R	-58-2700	+/-1.5C	Platinum-Rhodium/Platinum	High
B	32-3100	+/-0.5C	Platinum-Rhodium/Platinum-Rhodium	High

From the results in this table it can be realized that type-S, type-R, and type-B thermocouples are better for higher temperature applications and a longer life span at these higher temperatures, the other types of thermocouples have a hard time withstanding high temperatures. Being able to withstand high temperatures and remain accurate comes at a cost, these thermocouples are quite a bit more expensive due to the metal used and the accuracy of these sensors. For this project those sensors would be overkill. Type-N thermocouples consist of noble metals and are typically used for higher temperature applications, they have good stability and accuracy but are still expensive and would be overkill. Type-E thermocouples are moderately priced, they have a slightly stronger signal and can yield a higher accuracy than a type-K or type-J with a great temperature range, this would be a good thermocouple to consider with this project's application. Type-T thermocouples are very stable and are often used for applications that have very low temperature requirements such as cryogenics or ultra-low freezers. Type-J and type-K thermocouples are very similar to each



other, each one is very affordable, reliable at low to moderate temperatures and accurate. These types of thermocouple would also be good for this project's application. [33]

### 3.5.4. Side by Side comparison of Temperature Sensors

Comparing each type of temperature sensor side by side is a good way to weigh the pros and cons and make an overall decision for which type of sensor would be best for this project's application. Figure 11 below is based on the data found at "www.omega.com", this table shows each type of sensor and the applicable data in making a decision.

**Figure 20** - Temperature Sensor Type and Associated Data

Type of Temperature Sensor	RTD	Thermistor	Thermocouple
Sensor Accuracy	0.1 – 1C	0.05 – 1.4C	0.5 -5C
Temp. Range	-200 -650C	-100-325C	200-1750C
Linearity	Linear	Exponential	Non-Linear
Response Time	1-50sec	0.12-10sec	0.10-10sec
Noise	Rarely Susceptible	Rarely susceptible High resistance only	Very Susceptible, cold junction
Cost	High	Low- moderate	Low
Power	Constant source	Constant source	Self-powered

Based on the data in Figure 11 it is realized that the RTD sensor has good accuracy and linearity however it is the most expensive and has the longest response time. The Thermistor has good accuracy and sensitivity, the downside to this sensor is the narrow temperature range and non-linearity. The Thermocouple sensor has a good temperature range, is cost effective and can be self-powered however the trade-off is the accuracy of this sensor is not that good and cold junction compensation is necessary.

### 3.5.5. Thermal Humidity Sensors

Thermal Humidity sensors are used to measure the absolute humidity (AH) in the atmosphere. This type of humidity sensor is capable of operating in very dry climates or climates with a lot of water vapor in the air.

A thermal humidity sensor usually consists of two Negative temperature coefficient (NTC) thermistors, some resistors and a power source. One of the thermistors is used as a reference thermistor and hermetically sealed in a chamber with dry nitrogen, the other thermistor is exposed to the environment. When power is applied to the circuit the difference between the resistance in the thermistors is measured and reflects the humidity in the atmosphere.

The thermal humidity sensor is often used in pharmaceutical plants preparing drugs, used in food dehydration applications, and in clothing dyers. When choosing a humidity sensor for a project it is important to consider cost, range of humidity, temperature range, reliability and accuracy. The thermal humidity sensor is the most expensive type of humidity sensor, with this cost comes a very accurate humidity sensor that measures the absolute humidity in the atmosphere. The thermal humidity sensor is also capable of operating in an environment over a wide range of temperatures including very high temperatures. The thermal humidity sensor is very durable and able to survive in corrosive environments, this type of humidity sensor is often very reliable and has a long lifespan compared to others.

One of the main benefits of the thermal humidity sensor is it has the highest resolution out of all the types of humidity sensors, meaning it will provide the most accurate results. One of the downsides to the thermal humidity sensor is when it is exposed to other gases aside from nitrogen the readings of the sensor might be inaccurate. [34]

### **3.5.6. Capacitive Humidity Sensors**

Capacitive humidity sensors measure the relative humidity (RH) in the atmosphere. This type of humidity sensor is made up of layers, there is usually a hygroscopic polymer dielectric and two electrode layers on either side. As the humidity in the atmosphere changes the permittivity of the dielectric layer changes resulting in a change in measurable capacitance.

When choosing a capacitive humidity sensor there are a few things to consider, the material used as a dielectric, the metal used as an electrode and the desired accuracy of the sensor. The dielectric material is usually a polymer and the metal used can be either aluminum, platinum or chromium, the metal chosen as an electrode directly affects the accuracy of the sensor as well as the cost of this sensor.

Some of the benefits of the capacitive humidity sensor are it has a long-life span, a full range of RH humidity from 0% to 100%, accurate results when calibrated correctly, dirt and other contaminants have no effect on the output, the results are fairly stable and provides a linear output. Some of the down sides to the capacitive humidity sensor are they need to be calibrated often to maintain

accurate results, the circuitry for these types of sensors can be extensive depending on the output signal. The circuitry for this type of sensor would require more amplification and filtering which would add components to the cost. Another downside of the capacitive humidity sensor is the signal circuitry must be very close to the sensor, limiting the distance it can be placed.

Some of the applications of this type of humidity sensor are HVAC systems, weather stations, food processing, refrigerators, ovens, driers and printers. When choosing a humidity sensor for this project this type of humidity sensor would be able to satisfy the requirements necessary however the cost and limited distance span of the sensor may be limiting factors. [34]

### **3.5.7 Resistive Humidity Sensors**

Resistive Humidity sensors are made up of materials with low resistivity and two electrodes, the top layer of the sensor is made up of the low resistivity material, when it is exposed to humidity or water, it will absorb the water and change the resistivity between the electrodes, this resistivity change is measurable and related to humidity.

The top layer of this sensor is usually a salt, solid poly-electric or conductive polymer, the electrodes are usually made up of noble metals such as platinum, gold and silver. When considering a resistive humidity sensor for this project, it is important to consider cost, reliability, accuracy, distance from the circuit and size of the sensor. In this type of sensor, the size is relatively small, and it should easily be able to fit into this project's design. The cost of this type of humidity sensor as compared to the other types of humidity sensors is cheap. One of the biggest advantages that the resistive humidity sensor has over the capacitive current sensor is distance, the distance between the sensor and the circuitry for this sensor is very large allowing for remote mounting and use. Another advantage to this type of sensor is there is no calibration standard making it highly interchangeable if something fails. The range for a resistive humidity sensor is 5% up to 90% humidity. One of the disadvantages of this type of humidity sensor is it is very sensitive to chemical vapors, if it comes in contact with them the results will not be accurate, and it may need to be recalibrated. Another disadvantage to this type of humidity sensor is the output reading might shift if the sensor is used with water soluble products. This type of humidity sensor has a wide range of applications and is used in industrial, commercial, and residential industries. [34]

### 3.5.8 Sideby Side comparison of Humidity Sensors

Comparing each type of humidity sensor side by side is a good way to weigh the pros and cons and make an overall decision for which type of sensor would be best for this project's application. Figure 12 below compares the applicable data for each of these sensors to meet the necessary requirements for this project.

**Figure 21** - Humidity Sensor Data Comparison

Type	Thermal Humidity Sensor	Capacitive Humidity Sensor	Resistive Humidity Sensor
Range	0-100%	0-100%	5-90%
Accuracy	Absolute Humidity (AH)	Relative Humidity (RH)	Relative Humidity (RH)
Cost	Most Expensive	Moderate	Cheap
Power	Constant Power	Constant Power	Constant Power
Calibration	Must be calibrated before use	Must be calibrated often	No calibration standards, very interchangeable

Based on the data in Figure 12 it is realized that the Thermal humidity sensor has the best accuracy providing absolute humidity while both the resistive and capacitive humidity sensors only provide relative humidity. Table (#) shows that the resistive humidity sensor is the cheapest humidity sensor available and requires no calibration before or during use but has a smaller range. The capacitive humidity sensor offers the same range of the thermal humidity sensor at a cheaper cost but also has to be calibrated before and during use.

## 3.6. Heating System

There are two main types of heating systems that are applicable to this project, in this section these heating systems will be discussed along with the pros and cons of each of them.

### 3.6.1 Electric Heating System

In an electric heating system, large cables of resistance are laid under a surface and connected to a power source. When power is applied current is run through

the cables and they get hot, the heat produced then rises and heats the surface they are under.

The typical electric heating system is made up of three parts, a thermostat, temperature sensor and heating cable. In this type of system the thermostat determines when the system is on or off and regulates the temperature, the cable produces the heat and the temperature sensor provides temperature data to the thermostat.

This type of heating system typically draws about 10-15 Watts of power per square foot and most commonly gets connected directly to its own breaker in the homeowner's central power box. Some of the advantages that an electric heating system has over a hydronic heating system are it is possible to install on an existing driveway very easily, it lasts longer than a hydronic heating system, there is little to no maintenance required to operate and the response time is better meaning the whole driveway will heat up quicker. Some of the drawbacks to this type of heating is the increased cost of operation due to the amount of electricity it will consume, and some homeowners will not have the electricity capacity to run the system requiring them to install a secondary source.

The common issues with this type of system will directly affect how this type of heating is used in this project, the power source for this system will have to be well thought out and capable of sustaining operation of the system.

The three main installation methods for this type of system are loose cable, pre woven mesh with integrated cable and solid mats with an integrated cable. Loose cable the resistance cable loose and it has to be formed into the necessary shape, pre woven mesh with cable is a plastic mesh mat that has a resistance cable already woven inside of it, and a solid mat is a synthetic fabric, plastic sheeting or metal foil with a resistance cable enclosed inside of it. Figure 13 below compares each of these installation methods. [35]

**Figure 22** - Comparison of Heating Installation Method

<b>Type</b>	<b>Cost</b>	<b>Shape</b>	<b>Difficulty</b>
Loose Cable	Cheapest	Can conform to anything	Most difficult to install and mount cable
Mesh/Cable	Moderate	Not form fit has to be cut to fit	Moderate difficulty
Solid Mat/Cable	Most expensive	Difficult to modify comes as a square or rectangle	Easiest to install

It can be realized from Figure 13 above that although the loose cable is able to conform to any shape and is the cheapest option it is the most difficult to mount and install. The mesh cable mat is a great option, its biggest drawback is the cable cannot be cut or spliced into so conforming it to intricate shapes can be difficult. The Solid mat is the most expensive option but offers the most for the money, it has an easy installation and has an isolation layer around the cable that keeps the cable performed along with providing more heat for the same power draw. The biggest drawback with the solid mat is it will not conform nicely to intricate shapes and is difficult to modify, custom mats would be necessary which increases the cost.

### **3.6.2 Hydronic Heating System**

In a hydronic heating system a mix of water and antifreeze is heated with a boiler or hot water heater and a pump is used to circulate it through pipes or tubes under the surface that is being heated.

A hydronic heating system consists of a system of looped tubes that are placed under the driveway, roadway or walkway, a pump and a boiler or hot water heater. It is recommended for this type of system to run its own dedicated hot water heater if necessary but the existing boiler should have enough capacity to run the system. Typically a hydronic heating system is more complex to install than an electric heating system and can have a more expensive initial cost but will run more efficiently than an electric heating system.

Some of the advantages of this type of system are more heat is delivered for a lower operating cost over time, it is better for heating large areas, the owner can choose their power source for the boiler, whether its propane, oil or natural gas. The cost of these power sources can be cheaper than electricity in some cases. One of the main drawbacks to this type of heating system is it cannot be installed on an existing driveway, roadway or walkway, it would have to be ripped up and a new surface would be laid with the tubes embedded. Another drawback to this type of system is the tubes have to be connected to an inline pump and boiler sized appropriately for the area being heated, this may restrict the size of the surface and would not be good for very large areas such as roads or large walkways. Another drawback to this type of system is over time the tubes will corrode and eventually leak decreasing the lifespan of the system. The last drawback of this type of system is regular maintenance must be performed on the system to ensure that it is operating properly and efficiently, this will increase the operating costs. [36]

### 3.6.3 Side by Side comparison of Heating Systems

Figure 14 below compares the hydronic heating system and the electric heating system so their advantages and disadvantages can be weighed and a decision for this project can be made.

**Figure 23** - Heating System Comparison

Type	Electric	Hydronic
<b>Over All Cost</b>	Expensive over time	Expensive start up, cheaper over time
<b>Maintenance</b>	No maintenance required	Regular Maintenance required
<b>Installation</b>	Easy Installation	Difficult Installation
<b>Power</b>	Direct Connection to electricity source	Boiler: Propane, oil or Natural gas
<b>Response Time</b>	Fast	Takes a while to warm up entire system
<b>Restrictions</b>	Needs dedicated power supply	Cannot be installed under existing pavement

It can be realized from the table that each of these heating systems have pros and cons. The hydronic heating system is too expensive and intricate to implement for the needs of this project and from this research it can be realized that an electric heating system has more pros than cons and aside from the cost over time and the need for a dedicated power source the electric heating system will be able to satisfy the requirements for this project.

## 3.7. Lighting

In choosing a light source for this project, there are many different lighting technologies to consider: Incandescent, fluorescent, and LED being the main three that will be discussed in this paper. On top of physical constraints for each of these lighting technologies, other key performance indicators must be considered such as power consumption, cost, efficacy, maintenance, and lifespan.

### 3.7.1. Incandescent

Incandescent lighting was one of the first artificial lighting technologies that utilized electricity as its power source. It was groundbreaking in the late 1800's

when it was first invented, and a century later it was estimated that approximately 12.5% of all electricity consumed in the United States was due to incandescent lighting. Incandescent lighting is both economical and nonhazardous to manufacture; however, it is less energy efficient than the lighting technologies that came after it. A standard 60-W lamp will have an estimated lifetime of 1000 hours and will achieve 870 lumens total. Due to the physical construction of a typical incandescent lamp and the high wattage required to power it, incandescent lighting is not a viable option for the light source of this project. [37]

### **3.7.2. Fluorescent**

While incandescent lamps produce light by heating a filament until it glows hot (resulting in wasted energy in the form of invisible infrared light due to excessive heat production), fluorescent lighting has a different approach. Fluorescent lamps use an electric current to excite mercury atoms in argon, neon, and/or krypton gas. Then, the electrons of the gas give off energy in a process called luminescence. Fluorescent lamps are about 2-4 times as energy efficient than incandescent lamps, and they last 10-20 times longer (10,000-20,000 hours compared to 1,000 hours for incandescent lamps). However, fluorescent lighting does have some disadvantages. Due to the presence of mercury in a fluorescent lamp, they must be disposed of properly, and it can be hazardous if a bulb breaks. Fluorescent lamps are also not as pleasing to the human eye as a warm incandescent lamp. The light can flicker and many studies have shown that it can affect the mood of humans. [38]

### **3.7.3. LED**

Light emitting diodes have been around since the mid 1900's for use as indicator lights, infrared remote controls, etc., but it was not until about 10-15 years ago that LED lighting had been adapted as a suitable option for commercial and residential applications. In 2014, the Nobel Prize in Physics was awarded for LED's, and specifically for blue LED's that eventually produce white light. This award was given due to the potential for energy savings in lighting. LED lights have been proven to outperform both incandescent and fluorescent lighting in various categories. The lifespan of LED's is significantly longer than incandescent and fluorescent light sources. Oftentimes, the LED driver (which will be discussed in the next section of this paper) fails or breaks before the LED bulb itself will fail or break. While the upfront cost of an LED bulb is slightly higher than the cost of fluorescent and incandescent bulbs, the savings due to lifespan and energy efficiency are significant. Figure 24 below shows the total cost over approximately 14 years of a commercial or industrial lighting system that is used 12 hours per day. Energy cost and maintenance costs have been included in this figure. [39] [40]



**Figure 24** - Comparison of LED vs CFL vs Incandescent (Incandescent is labeled incorrectly as LED but in pink)  
 Permission requested from Science Direct

*B. Gayral / C. R. Physique 18 (2017) 453–461*

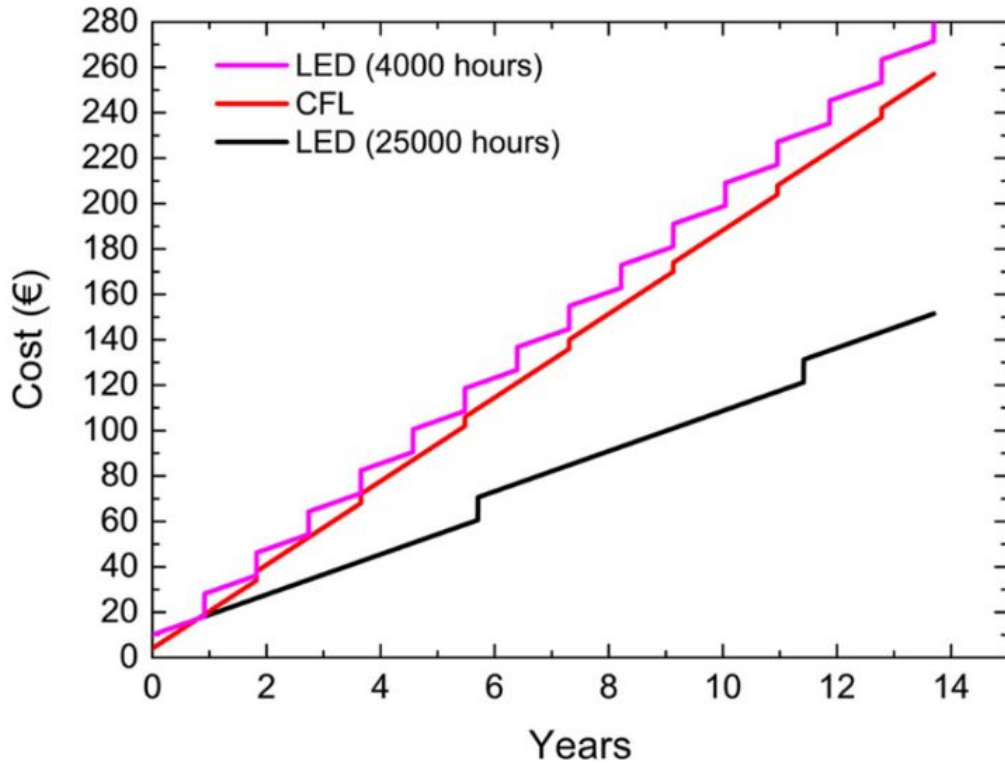

Due to the advancements in LED technology over the last 10-15 years and the flexibility that it gives the designer, LED lighting will be used for this project. Tape lighting seems to be the best option for this project as the space where LED's will be used is in approximately a 2 inch x 12 inch space.

### 3.8. LED Drivers

It has become fairly common knowledge over the last several years that LED lighting is going to be the way of the future. LEDs are much more energy efficient than its predecessor lighting technologies, and the cost has since become comparable in recent years as technology has advanced. However, there is one thing that LEDs need that most other lighting technologies do not require, and that is a driver. LED's only require somewhere between 12V-24V to run, and it needs to be direct current electricity. The problem with that is most voltage sources are much higher (120V-277V is standard for the US) and it is alternating current electricity.. What an LED driver does is take in a high voltage signal and rectify it to become a low voltage, direct current signal so that the LED

can operate properly. For this project, a decision will have to be made on whether an external LED driver will be used or an internal LED driver is a better option. [41]

### **3.8.1 Internal vs. External LED Drivers**

Depending on the physical space that an LED will be installed (whether it is tape light, a troffer, a downlight, a simple screw in bulb, cove lighting, etc.) a decision must be made on whether the driver will be integral to the device or external. Typical household LED bulbs that replace screw-in incandescent bulbs have an internal driver for easy replacement of fixture housings that were designed for incandescent bulbs. An external LED driver is typically used in an application such as a commercial open office or a school classroom where multiple downlights, long strips of cove lighting, multiple outdoor-rated lights, etc. are all on one zone of lighting. This allows for one driver to control multiple lights in one zone. An external driver for a larger zone might be larger and cost more money, but less will be needed.

As stated in section 3.7.3., an LED driver will most likely fail before the LED itself; therefore, if an LED driver is external then it is simple and easy to replace. That is one of the advantages of choosing an external driver because if the driver of an LED light that is internal to a device fails, the entire device would have to be scrapped and replaced entirely. There are advantages to using an internal driver though, specifically if storage is a concern. Installation and storage of an external driver would not be something that would need to be considered if the LED driver is internal. For this project, we must take into account both options because the maintenance of an external driver is much easier to manage, but this design is intended to be 1 ft. x 1 ft. so storage must be considered.

## **3.9. Lighting Control Protocols**

There are multiple approaches that can be used to dim lighting systems. Dimming was simple back in the mid 1900's when the only electrical lighting source that was commonly used was incandescent lighting. However, with the invention and adoption of fluorescent and later LED light sources, different dimming protocols had to be created. Below are some different dimming protocols including examples of why we use different protocols depending on the lighting source.

### **3.9.1. Phase Dimming**

Phase control dimming was developed in the 1960's as a way to dim incandescent lighting. The way that these dimmers worked is that they alter the

waveform of the AC voltage that powers the fixtures. The reason this works is because incandescent lights behave electrically like a resistor once they reach a steady operating temperature, so the control signal and the power signal are combined as opposed to delivering the control signal to the light source separately. These types of dimmers “cut” some of the sinusoidal waveform phase, which then reduces the RMS voltage of the waveform, thus dimming the light. [42]

**Figure 25** - Forward Phase dimming waveform (left) vs. Reverse Phase dimming waveform (right)

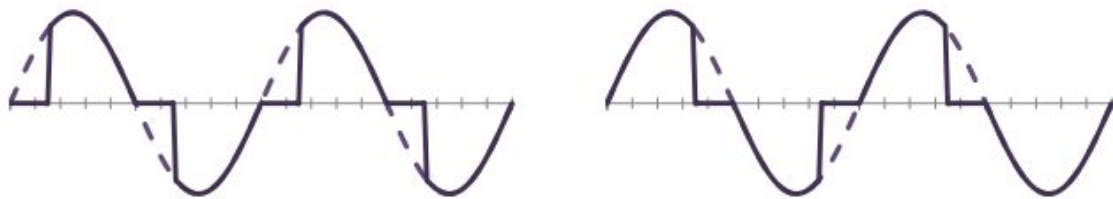

### 3.9.1.1. Forward Phase Dimming

Forward phase dimming can be named many different things. They can also be called TRIAC, leading edge, INC (for incandescent) or MLV (for Magnetic Low Voltage). These types of dimmers reduce the RMS voltage by removing the “forward phase” portion of the waveform (see Figure 25 above); hence the name forward phase dimming. Incandescent lighting uses forward phase dimming and some LED fixtures use it; however, forward phase dimming is not the most suitable form of dimming for LED fixtures because the light source is not as consistent as other options are. Many LED fixtures flicker at the low end (below 50%) of light output. [42]

### 3.9.1.2. Reverse Phase Dimming

Reverse phase dimming, like forward phase dimming, goes by many different naming conventions. These dimmers can be called reverse phase-cut, Electronic Low Voltage (ELV) or trailing edge dimmers. Opposite of forward phase dimming, reverse phase dimmers cut the trailing edge of the AC waveform to dim the lights. These dimmers were originally designed to improve the performance of low-voltage halogen lamps that operated on electronic transformers, but they more recently are used for some LED lighting (mostly tape lighting and track lighting) since electronic transformers are used for these systems. [42]

### **3.9.2. 0-10V Dimming**

0-10V dimming is an analog protocol that uses control wires to manipulate the voltage levels that communicate with a driver. This dimming method wasn't created until fluorescent fixtures came out and required drivers. LED fixtures also require drivers so 0-10V dimming was widely adopted in commercial general lighting for LED fixtures. One of the main differences between this analog protocol and others (phase dimming) is the need for control wires. The mains voltage only switches the light on and off, and then the control wires vary from 0-10V to dim the fixture: 10V being maximum output and 0V being the minimum output. Some of the advantages of 0-10V dimming it is a lower cost dimming method and there isn't any software commission needed. A couple of disadvantages are that addressing individual fixtures is not possible unless control wires are run for each individual fixture. This eliminates the advantage of low cost because the control wire cost will go up. Also, the polarity is important with 0-10V and can easily be mixed up. [43]

### **3.9.3. DMX-512**

The DMX lighting control protocol is unique from all other lighting control protocols because it not only allows for dimming, but it allows for color changing LEDs as well. DMX was originally created for the theatrical lighting industry for use at events such as concerts, sporting events, conferences, weddings, church services, etc. In recent years, many architectural lighting companies have been using the DMX protocol to create dynamic architectural lighting. DMX is a digital protocol that can have up to 512 channels per controller. Each channel is an individual LED from either an RGB or an RGBW light fixture (Red, Green, Blue, White). The DMX controller then sends a signal to all of the fixtures that it is connected to that alters the light level of these primary colors to mix other colors, light levels, and even rotate the head of a fixture if it is a rotating fixture. Some of the advantages of using DMX is that communication in this protocol is very fast, one DMX universe can handle 512 individual addresses, and it is specifically made for color dynamics. Some of the disadvantages are that it is very complex and takes a lot of training to understand the programming of the system. Also, special cables are required for communication. Because one of the goals for this project is to have color changing lights integral to the driveway, DMX is a possible option to use. [43]

## **3.10. Structure**

The goal for the physical structure of this project is that modular blocks be created for easy and simple installation. The structure will be square, 1 ft. x 1ft., and it will be layered. The top layer will consist of wood for the outer casing,

pavers that lay on top of either sand or concrete fines, and a transparent covering in the middle for the LED's to shine through. In the middle of the sand or concrete fines will be the heating cables that melts snow and ice that fall on top of the pavers. In the center layer, we will have a shelving that holds all materials on top in place. Lastly, the bottom layer will be mostly empty space so that the electronics can exist in that cavity. The only other materials will be small pieces of wood to help hold the shelving in place. In this section, discussions will be had on each material and different options to use.

### 3.10.1. Material of Top Structure

The main two materials at the top of this structure will be pavers and a transparent covering for an LED strip. Wood will also be at the top of this structure, but only as the outer casing to keep all other materials together. Wood will be talked about in depth in section 3.11.2. There is something else that needs to be considered as well, and that is a sealant for the structure to keep water from seeping down into the structure. Figures 26, 27 and 28 below show the layout of the top of this structure with descriptions, dimensions, and separation of materials.

**Figure 26** - Top View of Structure with descriptions

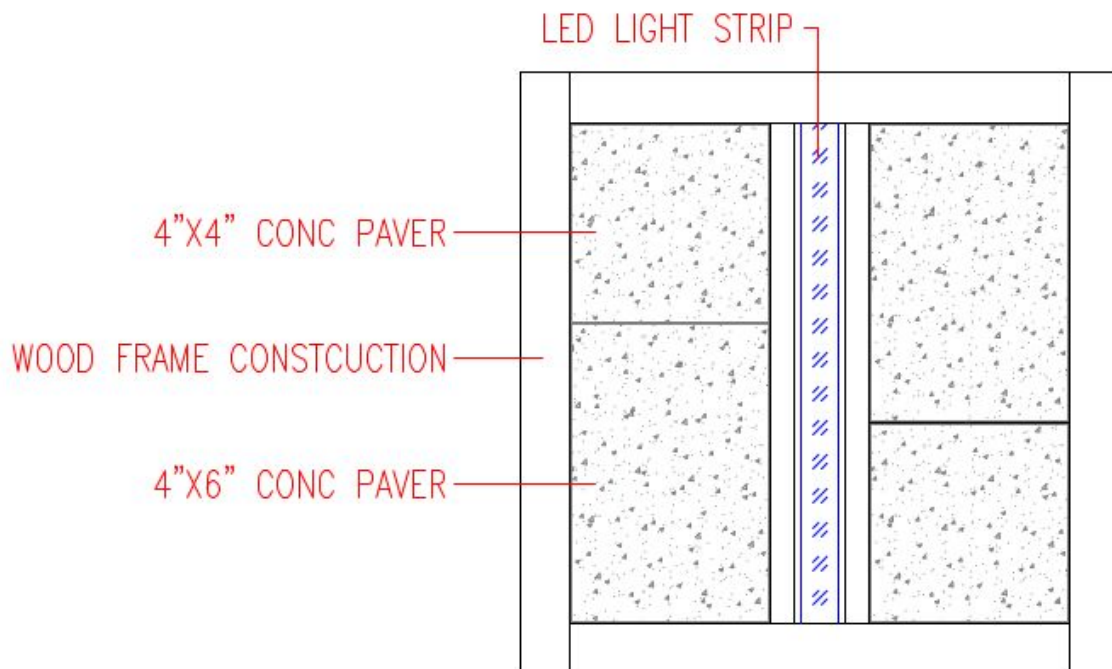

**Figure 27** - Top View of Structure with dimensions

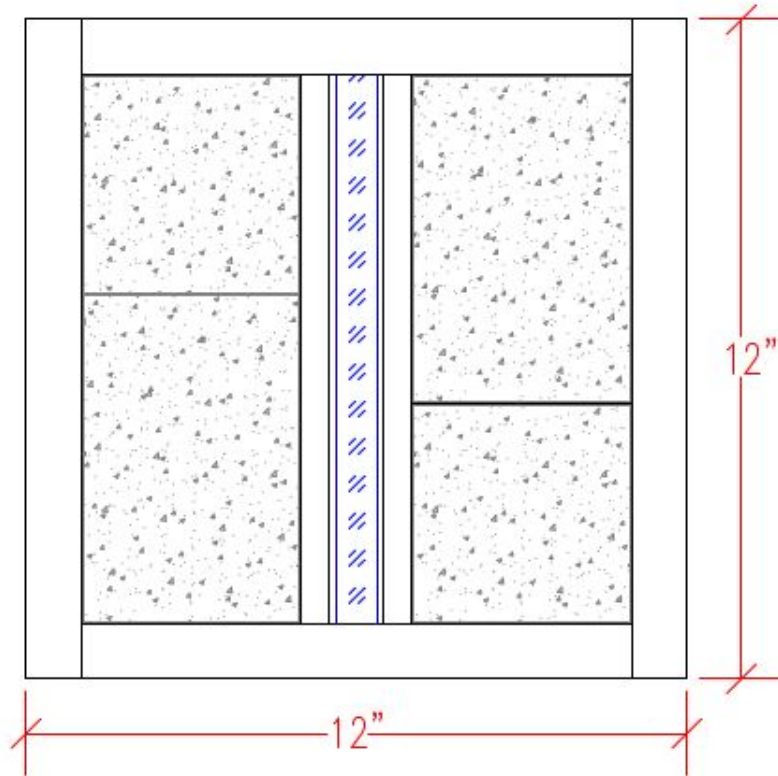

**Figure 28** - Top View of Structure with Separation of Materials

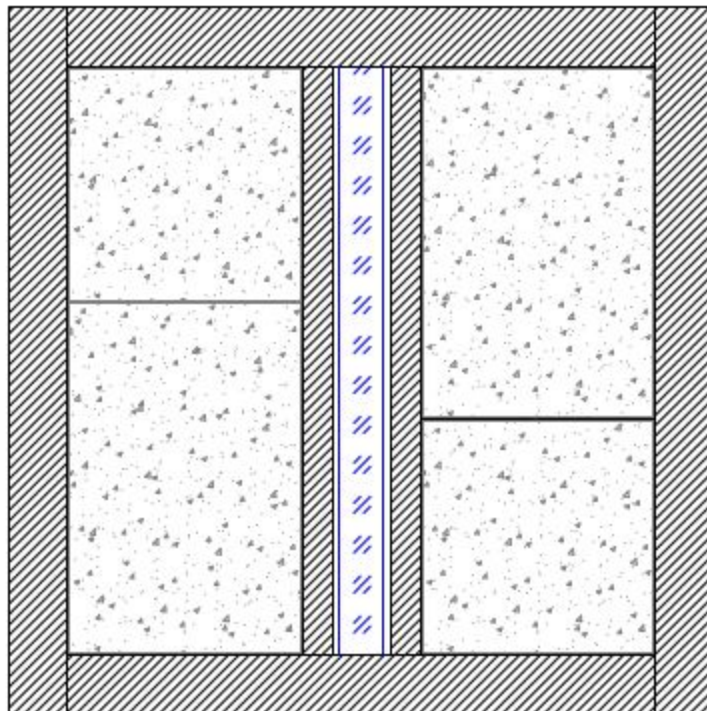

### **3.10.1.1. Pavers Over Heated Wires**

There are many companies in the industry that install heated driveways and walkways, and most of them have an option for pavers to be the top layer. Some companies in more industrial installations such as roadways use asphalt as the top layer. There are a few reasons why pavers will be a better option for this project. First off, pavers are very cost effective. They are available at most home improvement stores. They come in many different sizes, and if the size needed is not available then they are fairly easy to see with the right equipment. Also, there are a multitude of color options so that the homeowner can choose something that matches well with their home. With asphalt there are not many different color options. In paver installations there is always a base, and for this project the base will be where the heated wires exist. In the next couple of sections we will explore the advantages and disadvantages of each paver base.

#### **3.10.1.1.1. Paver Base**

Pavers cannot be placed on a hard surface. They also cannot be placed on an uneven surface. For this reason, a base of some sort needs to be placed underneath pavers prior to installation. This base must be level and compact as to not weather away over time. There are quite a few different paver bases, but the two that we will discuss in this paper are Sand and Concrete Fines. Both are very formable, and both can be compacted down to a point that it does not settle after the fact.

##### **3.10.1.1.1.1. Sand**

Using sand as a paver base is one of the most popular options. It is easy to spread and accessible anywhere that you can buy pavers. Typically pavers need to be able to drain water during any rain, and sand does this very well. However, with this project the goal is to keep water from seeping in to protect the electronics in the open cavity underneath the pavers. Also, when laying pavers the base needs to be as even as possible, and unfortunately sand shifts over time. With that being said, sand is not the most ideal base on its own. It is better when used in conjunction with a more durable base option such as crushed stone. [44]

##### **3.10.1.1.1.2. Concrete Fines**

Concrete fines, or sometimes known as Recycled Concrete Aggregate (RCA), is very similar to crushed stone, but it is more environmentally friendly to use. The RCA process has a smaller carbon output and takes less energy than mining

virgin aggregate. This makes RCA much more sustainable. The only issue with RCA is that there is a wide variety of different rocks that are used, making it difficult to know exactly what it contains. Certain stones and rocks do not allow for drainage as well, but like it was mentioned in the section above drainage is not a concern for this project due to the fact that the top layer will be sealed to stop any water from coming through. For this reason, concrete fines are a suitable option as the paver base for this project. [44]

### **3.10.1.2. Transparent Covering Over LED**

Having an LED strip for this product is one of the main reasons that separates this snow melting surface from others on the market. There are quite a few considerations when choosing a material for the LED to shine through. The material has to be strong enough to withstand the force that will be placed on it. It also must be able to withstand the elements of existing in an outdoor area. The temperature ranges that it must withstand should be from -30°F - 130°F. Snow, water, and rain must not damage it in any way. Another key factor in choosing a material will be the amount of light that shines through. We want to make sure that the product does not block a significant amount of light that will be transmitted from the LED.

There are a multitude of different transparent materials that we could choose, but the main considerations for this project will be plexiglass and fiberglass. In the sections below, we will discuss the advantages and disadvantages to each one, and we will ensure that the requirements above will be met.

#### **3.10.1.2.1. Plexiglass**

The simplest way to explain plexiglass is that it is a great alternative to glass. It is transparent, shatter proof, flexible, and strong. Plexiglass is made from polymers of methyl methacrylate. It is even more transparent than regular glass. Its transmittance factor is 0.93, whereas the transmittance range of glass is between 0.8 and 0.9. As mentioned above, there are many strengths to plexiglass, but there are a few disadvantages to consider. Plexiglass is much more prone to scratches than regular glass. It also can attract dust and possibly yellow overtime. The only function that plexiglass is not recommended for would be anything that involves mechanical wear. Due to the fact that this project will not endure any mechanical wear, plexiglass is a fine option for use as a transparent surface for the LED's to shine through. [45] [46]



### **3.10.1.2.2. Fiberglass**

Fiberglass is a very flexible material. It is used in such a wide variety of applications. Fiberglass is actually glass that is heated to a melted form, and then forced through superfine holes to create threads. These holes are measured in microns. Then, these threads are either woven into larger swatches or kept less structured, hence being called flexible materials. It can then be created to be many different things: some examples are swimming pools, doors, surfboards, boat hulls, exterior automobile parts, etc. Fiberglass is similar to plexiglass, but they are not synonymous with each other. Plexiglass is essentially just plastic with fiberglass embedded in it to increase its strength. The main difference is that with fiberglass, the glass strands are the main component, but with plexiglass the main component is reinforced plastic. Thus, fiberglass is typically stronger and more durable than plexiglass. For that reason, fiberglass will be considered as a possible option for the transparent covering over the LED's in this project. [45] [47]

### **3.10.1.3. Water Sealant**

Since there will be a cavity at the bottom of this structure for the electronics to exist, water must be blocked at the top of the structure. The most common use item for blocking water would be some form of caulk. Caulk is used in bathrooms, at exterior door connections, window connections, etc. with the primary function of keeping water out of areas that water ought not be in. Caulk is easily moldable to fit flush with a surface and appear aesthetically pleasing. The tough task here is not necessarily choosing a caulk but choosing the right caulk. There are many different types of caulk from interior types, exterior types, types for both interior and exterior, types with a silicon base, types with an elastomeric base, etc.

With that in mind, there are a few characteristic boxes that must be checked for this project. First off, the sealant must be rated for extreme weather conditions. It should be able to withstand temperatures well below freezing all the way to extreme exterior heat (-30°F - 130°F). It must be 100% waterproof. It must be adaptable to multiple surfaces, specifically wood, concrete pavers, and the transparent covering that will be used for the LED strip. It must also have a long lifetime to reduce maintenance on the material.

## **3.10.2. Material of Bottom and Side Structure**

The bottom of this structure will primarily be wood. The three main pieces to the bottom layer are the side casing, the layer beneath the paver base, and a bottom layer underneath that with a cavity created so that the electronics can exist in

that space. There are a vast variety of woods to choose from, so the section below will talk about the different types of wood and the pros and cons to each type.

Anytime wood is used, especially in a permanent exterior fashion, sealing the wood is very important. We will discuss different sealants to determine which is best for this project. Figures 29, 30 and 31 below show the layout of the side of this structure with descriptions, dimensions, and Separation of Materials.

**Figure 29** - Side View of Structure with Descriptions

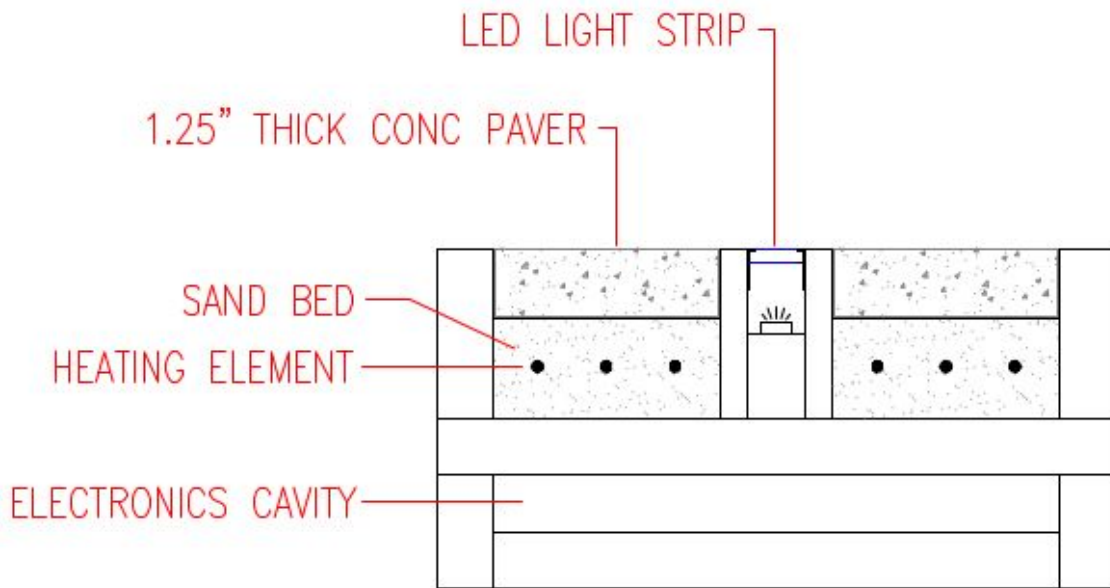

**Figure 30** - Side View of Structure with Dimensions

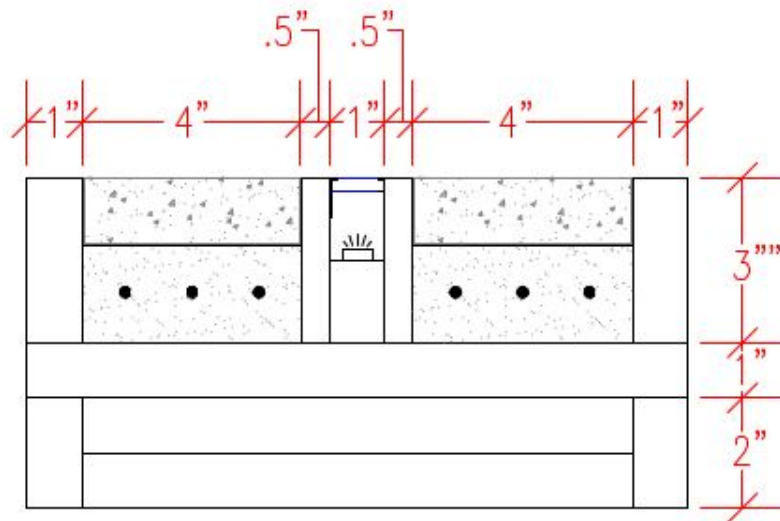

**Figure 31-** Side View of Structure with Separation of Materials

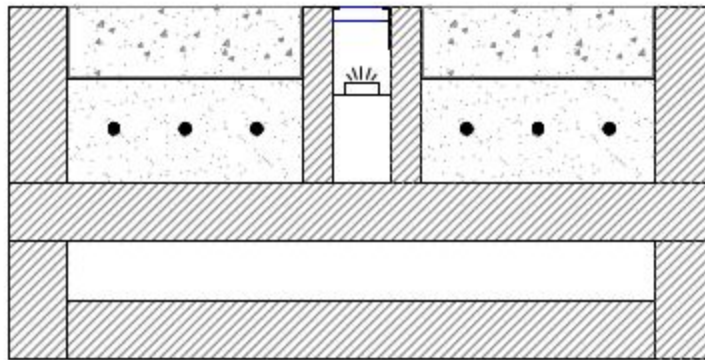

### 3.10.2.1. Wood

Wood is an excellent choice for this project for many reasons. First off, wood can be a very stylish and trendy surface. It can be sealed or painted many different colors, or it can be stained to really pull out the natural pop that it has. Secondly, wood is very cheap and easy to manipulate. It is the ideal product for a prototype for a project like this. It can be sawed, whittled, sanded, drilled through, etc. as long as the tools are available. Wood also lasts very long if treated correctly. If the correct coating is placed on wood, then it will last as long as this driveway needs to last.

There are three main variations of wood: softwood, hardwood, and engineered wood. Softwoods are woods that come from conifer trees. Conifer trees are trees that have needles and produce cones such as pine, cedar, fir, spruce, and redwood. They are typically used in building construction applications due to their ability to resist rot and insects. Hardwoods, unlike softwoods, come from trees that produce leaves and seeds instead of needles and pines. Some examples of hardwoods are oak, maple, cherry, mahogany, and walnut. Contrary to the name, hardwoods are not necessarily stronger than softwoods. Hardwoods are typically used in indoor applications such as flooring and furniture due to their beautiful and distinct wood patterns. Once they are cut, it is not recommended to use hardwood for outdoor applications. Lastly, engineered wood is self explanatory. It is wood that is not natural to the environment, but instead is manufactured typically from the waste wood of sawmills. Engineered wood was created mostly to meet certain size constraints that would be difficult to achieve with softwood or hardwood. Some examples would be plywood, oriented strand board, medium density fiber board, and composite board. Due to the different sizes of wood needed for this project, it may be beneficial for us to use engineered wood in some of the tighter spaces such as in between the pavers and the LED, and as the middle base beneath the paver base and above the cavity. Based on the information above, softwoods seem to be the best

option for the majority of this structure. Choosing the right one will be the next challenge.

First off, let's discuss Cedar woods. Cedar is a wood that many people are familiar with due to the aromatic smell and the interesting wood grain. It is ideal for outdoor building projects such as decks, patio furniture, pergolas, fencing, etc. The only concerns for cedar is availability to the right size. Other than that, Cedar wood is an excellent option for this project.

Next, Fir is an economical and strong softwood, but it does not have the typical wood grain that would make this more stylish. Fir is great for outdoor applications, but only if the plan is to paint the wood rather than stain it for the natural wood grain finish.

Pine is another fine option for this project. Pine trees grow at incredible rates, allowing for more pine trees to be planted and cut down in any given year. This also helps to drive the cost down due to the large supply. The only issue with pine is that it is typically suited for indoor use only unless it has been treated specifically for outdoor applications such as pressure treated lumber. Pressure treated lumber is mostly wood that is made from pine, spruce, and fir trees. It is made to be rot resistant and pest resistant. This wood type is ideal for decks, patios, porch railings, and other outdoor structures just like cedar wood is. The main issue with pressure treated lumber is that since it is made through a chemical process, it can be toxic. There is some controversy as to whether or not pressure treated wood is safe in garden beds or areas where food is grown. So as long as it is not placed near those areas, this is another good option.

The last wood to discuss is plywood. The only reason plywood is an option for this project is because it comes in sizes that might be difficult to obtain with cedar or pine. This structure needs to be 1ft x 1ft in total, and because of the pavers over top of the heating element and the LED strip, there is not a lot of extra room, and there is a possibility of needing some wood pieces that are only ½ an inch wide. Plywood would accomplish just that because it comes in a variety of different thicknesses with quarter-inch, half-inch, and three-quarter inch sizes being the most likely sizes one would encounter in a home improvement store. Plywood is very similar to pressure treated lumber since it is an engineered wood that is typically made from fir, pine, or spruce. [48]

### **3.10.2.1.1. Epoxy Resin Sealant**

Epoxy is a sealant that is made up of two parts, a resin and a hardener. Epoxy can be used on many surfaces, but for wood it can be used as an adhesive, a paint, a coating / sealant, or as a repair agent. It is super flexible to use and it is readily available in most hardware and home improvement stores.

There are quite a few pros to using Epoxy. The price of epoxy is much more desirable than polyurethane. The budget for the sealant of this project is a very small percentage of the total budget so price should not be our main consideration, but it is important nonetheless. Epoxy is also considered to be more durable than polyurethane. The bonds that epoxy creates are very strong and they can tolerate the greatest levels of compression strength. Lastly, epoxy resists humidity and moisture. Since this design will exist in an exterior environment at all times, that is a huge benefit.

There are a few cons when using epoxy that we must consider. Epoxy tends to not last as long as poly. Also, once it does fail, it is not necessarily easy to fix. The curing time for epoxy is also an issue. Typically it takes at least twice the length of time for epoxy to settle when compared to poly. When it comes to manufacturing, it is not ideal to double the amount of time just to allow a product to cure correctly. That could definitely mess with production. Next, epoxy surfaces tend to degrade when exposed to UV light. Obviously this is a large concern since the sun emits UV light, but there is a fix. UV resistant epoxy resin is a product that is out in the market, but it is more expensive to purchase which takes away the pro of epoxy being more cost effective. Lastly, epoxy has a high gloss appearance. This could be great for wood table tops or bar tops, but it is not ideal for this project. Being that this product will exist outdoors, the hope is that it looks as natural as possible. Epoxy definitely takes away a lot of the natural look that wood has. Also, a glossy surface is not ideal for anyone to walk or stand on. This can cause the surface to become slippery when wet, and a slippery surface is not good for legal reasons. [49]

### **3.10.2.1.2. Polyurethane Sealant**

Polyurethane is very similar to epoxy. It is composed of two parts just like epoxy, but unlike epoxy the user has much more flexibility when it comes to the ratio of compound to hardener that they wish to use. It really depends on what properties the end product should bring out. Polyurethane is different from epoxy in a few ways, one of which is the amount of industries outside of wood that polyurethane is used in such as automotive parts, decking, tennis grips, water tanks, electronic components, etc. Poly is a super adaptive substance indeed.

Using poly has several benefits. As was mentioned in the paragraph above, poly is super flexible. While it is true that epoxy is harder and more durable, the flexibility that poly has makes it last longer because it flexes with impact. This is great for a ground surface such as this project. The curing speed for poly is also a big plus. In most situations, poly cures faster than epoxy which is key to the production process. Adding onto the flexibility of Poly, it is very resistant to temperature extremes. When poly goes from hot to cold too quickly or from cold

to hot, it tends to flex rather than become brittle or breaking. Lastly, poly is much more resistant to scratches than an epoxy finish.

Like all products in this project, we must consider the cons as well. There are much higher upfront costs when using poly when compared to epoxy. Now when it comes to the long run, poly may end up being less expensive than epoxy because epoxy will have to be renewed much more frequently than poly. So poly will end up being a better value over time, but the cost of the setup will have to be considered. Next, while polyurethane is water resistant, it is not as good as epoxy at warding off water. If the product will spend a lot of time getting wet, it may be best to use epoxy. Obviously this is a huge factor because this project is built to withstand exterior conditions. Next, poly needs very fast set up times. The gel time for poly is not very long, so speed is of the essence when doing a project with poly. It is not very forgiving if the installer takes their time. Lastly, poly is not something that one should use if they do not have a lot of experience. It is not the end of the world for a small project, but if the project is a larger scale project, then the worker should have experience. Mistakes when using poly can get very expensive because of the high upfront costs. [50]

### **3.11 Net Metering**

Being able to sell energy back to power companies to lower an electric bill or earn a credit is a very big incentive for people that use renewable energy sources such as solar panels. This is possible through net metering, net metering is a mechanism that keeps track of all the energy that is generated and deposited back into the grid and provides a credit to the home or business owner to apply towards their bill.

For this project net metering is applicable because solar panels will be used to generate energy. In the warmer months of the year when the heating system is not needed the excess energy generated from the solar panels can be deposited back into the grid and offset the cost of owning them. Depending on the wattage rating of the solar panels a home or business owner will end up making money on owning them over time by injecting excess power back into the grid.

In order to participate in net metering the owner will first have to contact their power provider and allow them to install a new power meter. The new power meter is similar to the standard power meter except it is bi-directional allowing current to flow both ways. Net metering benefits both the owner and the grid, when the grid is under extensive load having people inject power back into it can help relieve some of the strain on the grid. Figure 32 is a diagram of how net metering works. [51]

**Figure 32** - Net metering Diagram

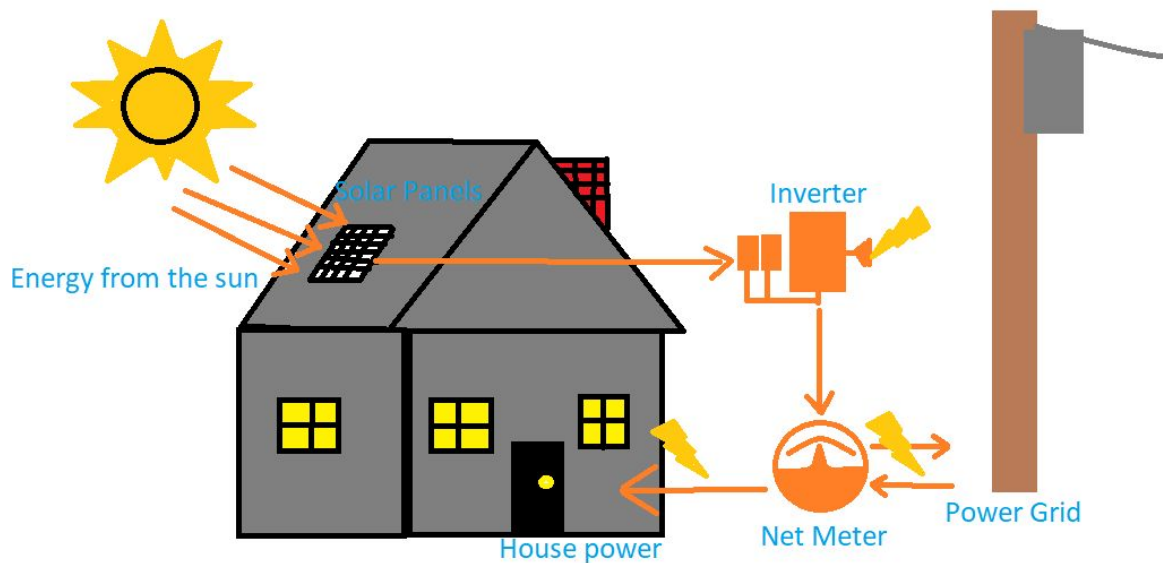

### 3.12 PCB Vendors

The PCB is one of the most important elements of this project, without it the project will not work as smoothly as intended and there will not be any future growth for the project as a product. When designing a PCB it is important to plan ahead and determine which company will be subcontracted to manufacture the designed PCB. It is important that the company chosen is reputable and if possible possesses certifications and education in PCB design and manufacturing. Education is necessary in order to meet the PCB standards and requirements created by IPC and other institutions. For this project one PCB will be sufficient and it will include an Atmega chip, pin headers, resistors and capacitors, a bluetooth module to interface with a smartphone application, the relays to switch between power sources and control when power is applied to the heating system and the proper inputs and outputs for the Atmega chip to interface with the sensors and LEDs. When choosing a company to consider for a PCB there are various different factors to take into account, for this project we will be looking at the customer reviews to determine the experience other people have had with the company, the manufacturing cost to adhere to a budget for this project, the companies estimated completion time and the location of the company to determine shipping time and return time if there are issues. When considering the manufacturing cost it is important to know the amount of PCBs necessary for this project, the total area of each PCB and the number of layers needed due to these conditions the manufacturing costs seen in this section are overestimated to ensure that even in the worst case situation, the cost is accounted for in the budget of this project. This section will discuss various PCB companies and vendors and their pros and cons to determine which company is most suitable to subcontract for this PCB. There are a lot of PCB companies

around the globe, for this project several different companies were researched and the decision was narrowed down to three companies.

### **3.12.1 Gold phoenix PCB**

The first company being considered for this project's PCB manufacturing is Gold phoenix PCB. Gold Phoenix PCB is a PCB manufacturing company located in Canada that outsources their manufacturing to China. Gold phoenix offers a wide variety of PCB options for different applications such as gold plated PCB, aluminum based PCB, ultra-thick, ultra-thin, PCB for power supplies and many other options. Gold phoenix PCB claims to adhere to all the PCB quality and IPC standards. Gold phoenix also claims to provide a quality product that will leave the customer satisfied for years. One of the important things that Gold phoenix PCB claims is that they excel in providing a superior product that is capable of meeting the customer's exact requirements at a cost effective rate. Gold phoenix PCB offers a quality guarantee, quick lead time and great customer service which is another huge advantage when choosing a PCB vendor. Gold phoenix offers many different payment selections even including PayPal along with many shipping carriers. One of the most appealing options offered at this time by Gold phoenix is a deal for hobbyists, it is \$2 per inch for a PCB and shipping to North America is \$5. Being that the PCB for this project will be rather small this option might be a good cost effective choice. One of the downsides to Gold phoenix PCB is they send their product directly from the factory and the factory is located in China, this leads to long shipping times or expensive shipping costs to expedite orders. If there was an issue with the PCB and it had to be sent back for any reason this could potentially cause an issue. The overall customer reviews for Gold phoenix are mostly positive with the exception of a few customers that were very unhappy and would not recommend dealing with Gold phoenix. [52]

### **3.12.2 4PCB**

4PCB is a United States based company that manufactures custom PCBs in house. 4PCB offers PCBs that are capable of meeting advanced designs and can meet demanding requirements including laser-drilled microvias, cavity boards, heavy copper up to 20 oz. and microwave and RF boards along with boards with up to 40 layers. Since 4PCB is in the U.S. they can offer turnaround times as quick as 24 hours for customers located in the U.S. for both standard 0-10 layer boards and custom 0-40 layer boards, 4PCB claims to adhere to the IPC standards and pledges to provide a quality product that will satisfy the customers' expectations whether it's for a hobby or application. 4PB claims to be capable of creating MIL-SPEC PCBs as well. For the most part all of the customer reviews were very positive with the only complaint being cost. One of the tradeoffs of choosing 4PCB is the cost, this company is one of the most



expensive options with a shipping cost of roughly \$100 with no promotional deals, and a manufacturing cost of \$150. [53]

### **3.12.3 Express PCB**

Express PCB is another United States based company that offers PCB CAD software along with PCB manufacturing services. Express PCB manufacturing offers various packages of PCB options such as standard, standard mini-board, mini-board, proto, and production. Each of these options allow for different configurations or customizations for a PCB. For this project the most applicable option would be the standard package which includes a quantity of 1-5000 PCBs, up to 2 layers each and a Tin-Lead surface finish. The customer reviews for this company are mostly positive with a few bad reviews regarding quality and their overall experience with the company. Shipping costs for Expresspcb are anywhere between \$40-120 depending on the quantity of PCBs, and the shipping times are between 5 and 7 days. [54]

### **3.12.4 Side by side comparison of PCB vendors**

Figure 33 compares the estimated manufacturing cost, shipping cost, location of the company, customer reviews and the estimated timeframe that it would take the company to complete the order. From Figure 33 below it was realized that Gold phoenix was the most cost effective option, 4PCB was the most expensive option and Express PCB was priced moderately. The shipping costs for ExpressPCB is the most cost effective and since Express PCB is located in the United States the turnaround time should be quick. Gold phoenix has the longest turnaround time and is located in China making it difficult to ship back if a problem arises. 4PCB is the only company listed that got all positive reviews and has the fastest turnaround time option. Based on this table it can be realized that 4PCB would be an ideal and viable option for this project.

**Figure 33 - PCB Vendor Comparison**

<b>Company</b>	<b>Manufacturing Cost</b>	<b>Shipping cost</b>	<b>Company Location</b>	<b>Customer reviews</b>	<b>Estimated order completion</b>
Gold phoenix PCB	Cost effective	~\$100	China	Mostly Positive	7-10 business days
4PCB	Expensive	~\$100	USA	Positive Reviews	As quick as 24 hours or 7-10 business days
Express PCB	Moderate to Expensive	~\$50	USA	Mostly Positive	5-7 day turnaround

### **3.13 Existing Products and Technologies**

When creating a new project it is important to consider which products already exist. Existing products or designs within existing products could potentially be patented and it is important to understand copyright laws. In the case of this project there are a few products that do already exist or are in a development phase. In this section the existing products and designs will be discussed along with the impact that these products had on this project.

#### **3.13.1 Solar roadways**

Solar roadways is a company based in the United States that developed a tile based roadway system that utilizes LEDs, a heating system and an integrated solar panel that produces enough energy to power itself. One of the key selling points of this project is that it will sustain itself energy wise and provide clean energy to the power grids. Recently solar roadways went into phase four of their development and was awarded a \$750,000 contract with the USDOT to continue development of these tiles. In the process of completing this contract, solar roadways installed a small sidewalk made of tiles in southern california to test how they would hold up in the weather conditions and public use. Our project has a similar idea but is being executed very differently, the solar panel will not be integrated into the tile, the tile will not be made of glass or epoxy and will only utilize a strip of LEDs as opposed to a full panel. By simplifying our system we

were able to make it more rugged and durable while maintaining the key features. [55]

### **3.13.2 Existing Technologies**

Aside from solar roadways many other United States based companies have come up with a heated driveway system. These heat systems usually consist of either electrical heating systems or hydronic heating systems. An electrically heated driveway utilizes cables that are run under the pavement, when power is applied to these cables due to the resistance of the cable heat is dissipated and rises up heating the pavement. A hydronic heating system is a system of pipes that are run under the pavement and connected to a water heater or boiler, the boiler heats the water and antifreeze mix and circulates it through the pipes, the pipes then heat up the surface pavement above, this system is more difficult and costly to install. For this project the electrical heating system technology was researched and utilized.

## **4. Design**

This section will cover the overarching design aspects for both the software and hardware of the smart heating tile. The design sections will focus more on how the components will interact with each other rather than simply what the components do. The design section will exclusively talk about design components that have been decided upon that will end up in the final prototype/product.

### **4.1 Software Design**

For the smart tile's software aspects, a mobile application communicating with the Arduino Uno Wi-Fi has the lowest overhead for implementation, and is the most reliable and user friendly route to meet all the requirements for the design. The outlined design requires a marriage of the mobile application and microcontroller's communication through Wi-Fi. The mobile application will communicate to the microcontroller through an API written in the mobile application's backend which will ping the microcontroller to send the inputs for the heating element and LEDs

#### **4.1.1 Microcontroller Logic**

The microcontroller will be the controlling factor on whether the heating function or LEDs are turned on or off. The microcontroller will receive data from the humidity and temperature sensors. The main logic within the microcontroller is to analyze this data and send the input to the heating element to turn it on. It will

also send inputs to the LEDs according to the heating element logic or logic stemming from the phone application. The microcontroller will also handle communication requests from the phone application about turning on or off the heating element, or leaving it off and ignoring the temperature and humidity sensor functions.

The microcontroller's logic will be written in C, as this is a high level language that the Arduino Uno Wi-Fi uses. This will allow us to send API requests to and from the phone application to send and receive important information relative to the user's need for control over the device remotely. This includes battery level, the current status of heating element, the current status of the LEDs, as well as allowing the user to change the color of the LEDs.

### **4.1.2 Phone Application**

The mobile application, as outlined in the block diagram, needs to be able to read sensor data input sent from the microcontroller about the heating element and LED's status. Another important aspect of the mobile application is for it to be understood without instructions and for it to have a minimal and simple design so as to not overwhelm the user. It also needs to be able to send data to the microcontroller through the API to change the status of the LEDs and to turn the heating element on or disable it. All of these actions will happen in the mobile application's user interface as shown in Figure 34 below.

**Figure 34** - Mobile Application Mockup

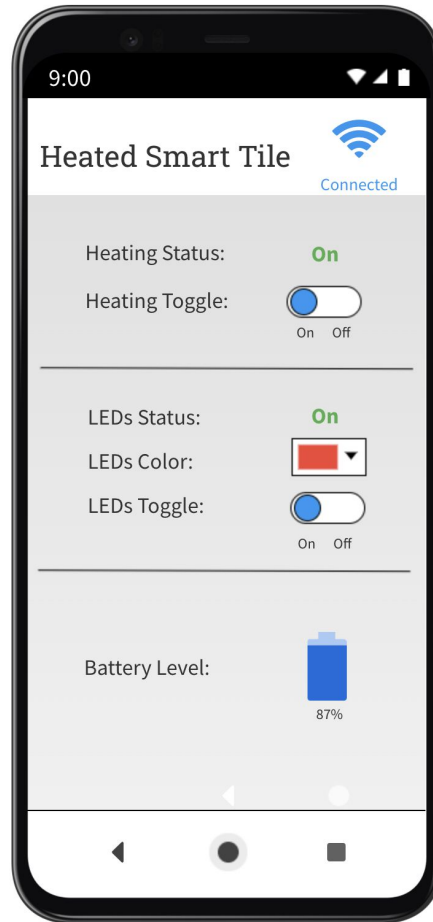

At the top of the page, the user will be able to see whether or not the smart tile is on the Wi-Fi. The Wi-Fi icon will be displayed as blue when the mobile application can establish a connection to the smart tile system. If it is not connected, the icon will be gray and the wording will change to say “Not Connected.”

The heating section will display if the device is currently heating the surface. It also has a toggle if the user wants to turn off the automated heating programming that the smart tile’s microcontroller manages. The LED section operates similarly in that it shows if the microcontroller has turned the LEDs on or off. The user will be able to select what color they want the LEDs to show through the dropdown menu. The user will also be able to turn the LEDs on or off.

The bottom section will show the battery percentage so that the user can see if the battery is charged, charging, and grants the ability to see if the battery will not

charge for some reason. This allows the user to troubleshoot their connection or external battery configuration to ensure that the device is working properly.

### **4.1.3 Communications**

Consistent and reliable communication between the microcontroller and the mobile application is paramount to user satisfaction and the overall functionality of the device, which is why Wi-Fi is the preferred and chosen method to carry out the transmission of data. The Arduino Uno Wi-Fi has a built in Wi-Fi module which will be able to connect to the user's home network. This provides a safe and secure medium for sensitive data about the device so that it cannot be tampered with, which could potentially cause a hardware failure if a person with malicious intent were to try and attack the system.

To communicate efficiently between the microcontroller and the mobile application, a basic API (Application Programming Interface) will be set up on the phone's backend. When the user opens the phone application, the application will request, through the API, the latest data about the sensors and current logic settings on the device to update the frontend of the mobile application. This will ensure that the phone application always displays the most current information about the system.

When the user interacts with a button that has a function requiring the microcontroller to change a setting with the device, it will send a request to the microcontroller over the secured connection. The request will then be parsed by the microcontroller's logic and the user's actions will be followed by an action from the microcontroller. The microcontroller will then send a response back to the mobile application to report the new data.

## **4.2. Hardware Design**

Below is the schematic for this project. This schematic consists of an Atmega328 MCU, an AC/DC converter, a DC/DC converter, a triac relay for control of the heating system, the LED strip design, the temperature sensor design, and the humidity sensor design.

**Figure 35 - Design Schematic**

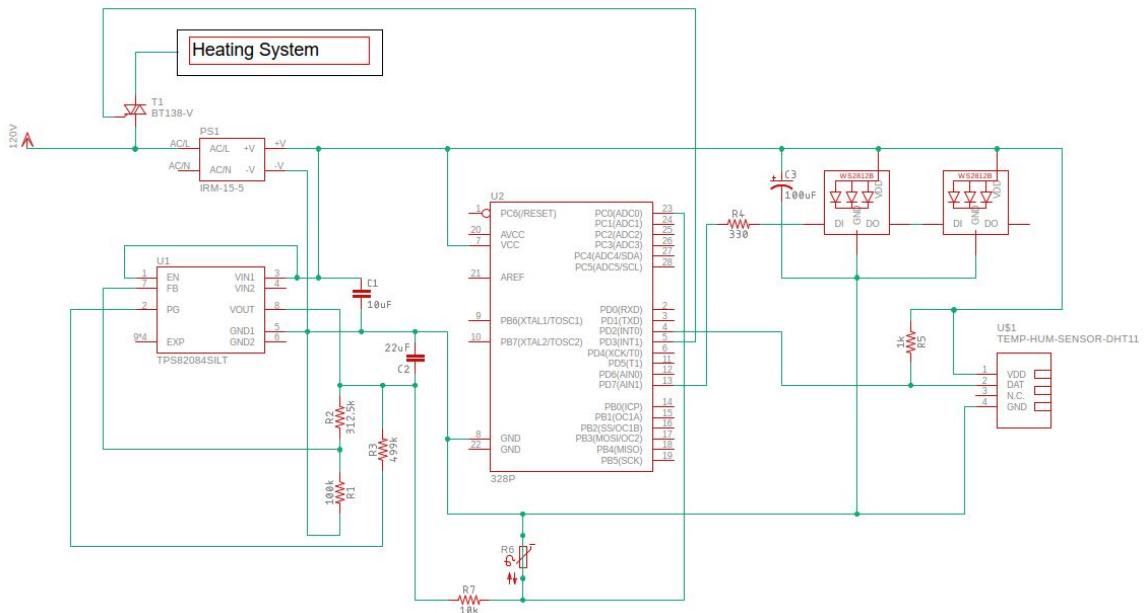

**Figure 36 - Design Schematic with labels of areas**

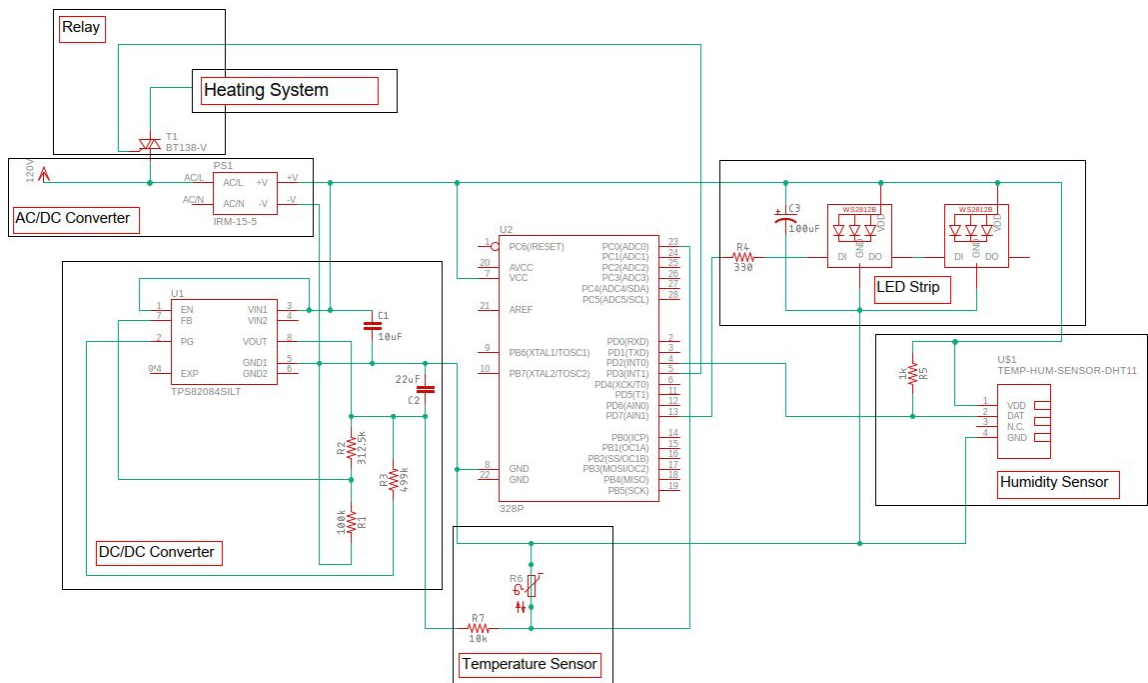

## 4.2.1 Power Design

The power design for this project consists of utilizing solar and an electrical outlet to supply power to the Smart Tiles. The solar portion of the Tiles will be mainly for regeneration and saving electrical cost, but the main power supply will come

from the home outlet. This will ensure that constant power is applied, on demand. Since the Tiles will work off of 120V AC, we will need to utilize the standard Nema 5-15 electrical plug. This is the most common electrical receptacle in North America, where mainly this product will be made for. It consists of the two poles, 3 wires with grounding capability to reach a maximum of 15 Amps at 120V AC. From this Voltage, we can start to transform the voltage down to feed the correct voltage and power the components in the Tile system. The initial Power Flow will come from the mains 120 V AC outlet, and will then be converted to a DC Voltage by the AC to DC convertor, where it will go on to the DC to DC convertor, to a step down transformer to power the microcontroller, Temperature sensor, Humidity sensor and LEDs. The right conditions will allow the microcontroller to feed 5v to the control side of the relay, where in turn will switch power on to the heating tile system. When conditions are broken, or no longer applicable, the power will turn off.

## **4.2.2 Sensor design**

This project utilizes two sensors, a thermistor NTC temperature sensor along with a capacitive relative humidity sensor. These sensors are an integral part of this project and necessary in order to automate the heating system and provide safe conditions. In this section the circuit design for these sensors will be discussed along with how each sensor will interact with the Atmega chip and for prototype purposes the Arduino.

### **4.2.2.1 Temperature sensor**

For this project's application it was determined that a NTC thermistor would be the best type of temperature sensor. The thermistor chosen for this project is the 10k precision epoxy NTC thermistor, with part number 3950 NTC. This thermistor was chosen because it has an accuracy of +/-1%, the coating on the wires has a temperature range from -55 degrees celsius up to 105 degrees celsius which is beyond this project's temperature scope. Another reason this thermistor was chosen for this project is for the ability to mount the sensor on the surface of the tile for accurate surface temperature readings. Another advantage to this specific thermistor is since it is epoxy coated it cannot be damaged by dust or water. This thermistor fits the IEC sensor standard at a rating of IP68k, meaning it has the highest rating for dust proofing and a high rating for water proofing. These are important characteristics to have because this sensor will be exposed to an outdoor environment with snow, ice and water. The Atmega chip is capable of measuring the temperature based on voltage through an analog to digital converter (ADC), since this thermistor measures the change in resistance and allocates it to a temperature the resistance will need to be converted into a voltage. To change the resistance into a voltage, a voltage divider circuit is necessary, a fixed resistor is used with a known value and the variable



resistance is used to represent the sensor data, a known power source is used as Vcc. The equation: can be used to find the thermistors temperature as a voltage. This sensor operates by increasing resistance as the temperature decreases and decreasing the resistance as the temperature increases, Figure 37 displays the lookup table from the data sheet. The lookup table in Figure 37 is necessary to understand how to properly program the software to calculate temperature. [56]

**Figure 37** - Temperature Sensor DataSheet

Resistance @ 25°C = 10KΩ		$B_{25/50} = 3950K$									
T(°C)	R(KΩ)	T(°C)	R(KΩ)	T(°C)	R(KΩ)	T(°C)	R(KΩ)	T(°C)	R(KΩ)	T(°C)	R(KΩ)
-40	277.2	1	30.25	42	4.915	83	1.128	124	0.3434	165	0.1265
-39	263.6	2	28.82	43	4.723	84	1.093	125	0.3341	166	0.1239
-38	250.1	3	27.45	44	4.539	85	1.059	126	0.3253	167	0.1213
-37	236.8	4	26.16	45	4.363	86	1.027	127	0.3167	168	0.1187
-36	224.0	5	24.94	46	4.195	87	0.9955	128	0.3083	169	0.1163
-35	211.5	6	23.77	47	4.034	88	0.9654	129	0.3002	170	0.1139
-34	199.6	7	22.67	48	3.880	89	0.9363	130	0.2924	171	0.1115
-33	188.1	8	21.62	49	3.733	90	0.9083	131	0.2848	172	0.1092
-32	177.3	9	20.63	50	3.592	91	0.8812	132	0.2774	173	0.1070
-31	167.0	10	19.68	51	3.457	92	0.8550	133	0.2702	174	0.1048
-30	157.2	11	18.78	52	3.328	93	0.8297	134	0.2633	175	0.1027
-29	148.1	12	17.93	53	3.204	94	0.8052	135	0.2565	176	0.1006
-28	139.4	13	17.12	54	3.086	95	0.7816	136	0.2500	177	0.0986
-27	131.3	14	16.35	55	2.972	96	0.7587	137	0.2437	178	0.0966
-26	123.7	15	15.62	56	2.863	97	0.7366	138	0.2375	179	0.0947
-25	116.6	16	14.93	57	2.759	98	0.7152	139	0.2316	180	0.0928
-24	110.0	17	14.26	58	2.659	99	0.6945	140	0.2258	181	0.0909
-23	103.7	18	13.63	59	2.564	100	0.6744	141	0.2202	182	0.0891
-22	97.9	19	13.04	60	2.472	101	0.6558	142	0.2148	183	0.0873
-21	92.50	20	12.47	61	2.384	102	0.6376	143	0.2095	184	0.0856
-20	87.43	21	11.92	62	2.299	103	0.6199	144	0.2044	185	0.0839
-19	82.79	22	11.41	63	2.218	104	0.6026	145	0.1994	186	0.0822
-18	78.44	23	10.91	64	2.141	105	0.5858	146	0.1946	187	0.0806
-17	74.36	24	10.45	65	2.066	106	0.5694	147	0.1900	188	0.0790
-16	70.53	25	10.00	66	1.994	107	0.5535	148	0.1855	189	0.0774
-15	66.92	26	9.575	67	1.926	108	0.5380	149	0.1811	190	0.0759
-14	63.54	27	9.170	68	1.860	109	0.5229	150	0.1769	191	0.0743
-13	60.34	28	8.784	69	1.796	110	0.5083	151	0.1728	192	0.0729
-12	57.33	29	8.416	70	1.735	111	0.4941	152	0.1688	193	0.0714
-11	54.50	30	8.064	71	1.677	112	0.4803	153	0.1650	194	0.0700
-10	51.82	31	7.730	72	1.621	113	0.4669	154	0.1612	195	0.0686
-9	49.28	32	7.410	73	1.567	114	0.4539	155	0.1576	196	0.0672
-8	46.89	33	7.106	74	1.515	115	0.4412	156	0.1541	197	0.0658
-7	44.62	34	6.815	75	1.465	116	0.4290	157	0.1507	198	0.0645
-6	42.48	35	6.538	76	1.417	117	0.4171	158	0.1474	199	0.0631
-5	40.45	36	6.273	77	1.371	118	0.4055	159	0.1441	200	0.0619
-4	38.53	37	6.020	78	1.326	119	0.3944	160	0.1410		
-3	36.70	38	5.778	79	1.284	120	0.3835	161	0.1379		
-2	34.97	39	5.548	80	1.243	121	0.3730	162	0.1350		
-1	33.33	40	5.327	81	1.203	122	0.3628	163	0.1321		
0	31.77	41	5.117	82	1.165	123	0.3530	164	0.1293		

Figure 38 below shows how this sensor can be implemented into the PCB design.

**Figure 38** - Temperature Sensor Schematic Snip

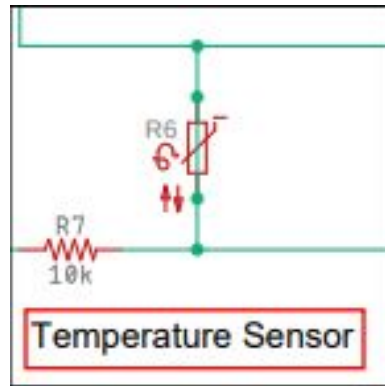

## 4.2.2.2 Humidity sensor

For this project's application it was determined that a capacitive relative humidity sensor would be the best humidity sensor. The humidity sensor chosen was the DHT11 Relative humidity sensor. This sensor uses a pull up resistor and an NTC thermistor to sense the humidity in the air. The sensing capacitor has two electrodes with a dielectric moisture layer between them as the humidity or moisture changes, the capacitance will also change. One of the pros for this sensor is it is capable of sensing both humidity and temperature, so although there is a separate thermistor temperature sensor specifically for the surface temperature of the tile, this sensor will be able to sense the outdoor air temperature. Another advantage to the DHT11 humidity sensor is it can produce a digital output making it very easy to interface with the Atmega chip. This humidity sensor has a temperature range from 0 degrees celsius up to 50 degrees celsius and a humidity range from 20% humidity up to 80% humidity with a +/-5% accuracy, which is a good range for this project's application of this sensor. This sensor will receive power 3-5V of power and have a sampling rate of 2Hz. This sensor has 4 pins on it, Vcc, ground, a data pin and an extra pin, when connecting this sensor to the controller a pull up resistor will be used to get the proper reading. Figure 39 shows how this sensor will be implemented into the PCB design.

**Figure 39** - Humidity Sensor Schematic Snip

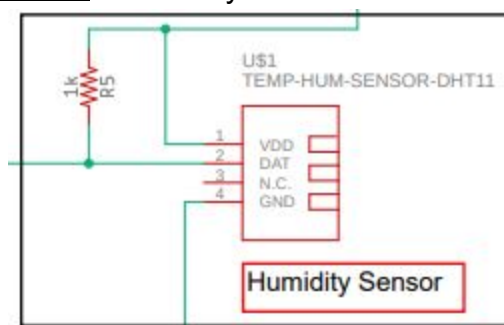

### 4.2.3 Heating element design

For the heating system of this project a conducting cable made by warmlyours will be used. This cable has an input voltage of 120VAC and will need to be powered from the wall outlet. This cable will be connected to a relay, the relay will be controlled by the Atmega chip, when the surface temperature sensor and the humidity sensor reach the specified values the pin on the Atmega chip will receive power and the relay will be energized, when the relay is energized power from the wall outlet at 120VAC will be applied to the cable. When the sensors reach the maximum limit set for temperature or humidity, the pin on the Atmega chip will be turned off and the relay will also be turned off cutting power to the heating cable. From the data provided by warmlyours [57] this cable is capable of producing 12 Watts of heat per linear foot. This cable draws 4.17A of current and the conductor is 28.8 ohms of resistance. Since this cable is intended to be used on a driveway, the shortest length offered by warmlyours is 10.7 square feet so in order to fit this cable in the structure of this project the cable will have to be layered or cut and modified quite a bit to fit.

### 4.2.4 Lighting Design

For the lighting portion of this project, we have decided to go with a color changing LED strip. There are many reasons why we have chosen LED. First off, it is by far the longest lasting lighting technology. It is also the most power efficient lighting technology. Lastly, the cost for an LED strip is nowhere near what the cost for LED lighting was 10-15 years ago. It is very affordable. The product we will be using is the WS2812B LED strip. There are so many reasons why this product is the best option for this project. First, the driver is internal for each individual LED on the strip. The control circuit and the LED share the only power source. Speaking about power, the input voltage for this is +5V which is the same input voltage that our board will need, so that source can be shared between the MCU and the LED strip. The driver for each LED has a built-in reshaping circuit such that wave-form distortion does not accumulate. Lastly, each pixel consisting of the three primary colors can complete a full color display by achieving 256 brightness display.

Each individual LED has 4 ports. They are the power supply LED (VDD), the control data signal output (DOUT), Ground (VSS), and a control data signal input (DIN). The great thing about this product is that the VDD, VSS, and DOUT for each LED closest to the power is connected to the VDD, VSS, and DIN respectively of the next LED in line already. Figure 40 below gives a good visual of a typical application. This makes the installation super simple because the connections just need to be made at the first LED and that is it. Then, if a cut needs to be made, just simply cut on the cut line and solder extender cables to

extend the strip. This method will be used when connecting multiple tiles together. Each LED is individually addressable and the control can be written through the code. The control protocol is NZR communication mode. It is not a standard protocol, but it works great for small projects such as this one where the LED is not the main portion of the project, but rather a small bonus. The DIN port receives data from the controller. The first pixel receives 24 bits of data, then the internal driver transmits that data through the DOUT port where it then gets sent to the next cascade pixel's DIN port. The reason 24 bits of data is used is because we have 8 bits for each color: 8 for red, 8 for green, and 8 for blue. It is important to note that the order of that data must be Green, then Red, then Blue because that is how the LED's are configured inside of the chip. In terms of circuitry, there are a few things to consider when designing the schematic. We could just simply connect the power, data, and ground wires directly from the sources, but we may have a few issues. First thing to consider is that there is usually noise on a data input line. We will be using a 330Ω resistor on the data line to reduce that noise. Also, external voltage supplies do not always produce the smoothest signals. To help with that, we will be using a capacitor across the +5V power supply and ground of approximately 100μF to smooth it out. [58]

**Figure 40** - Typical application circuit of a WS2812B LED strip. Permission received from Worldsemi

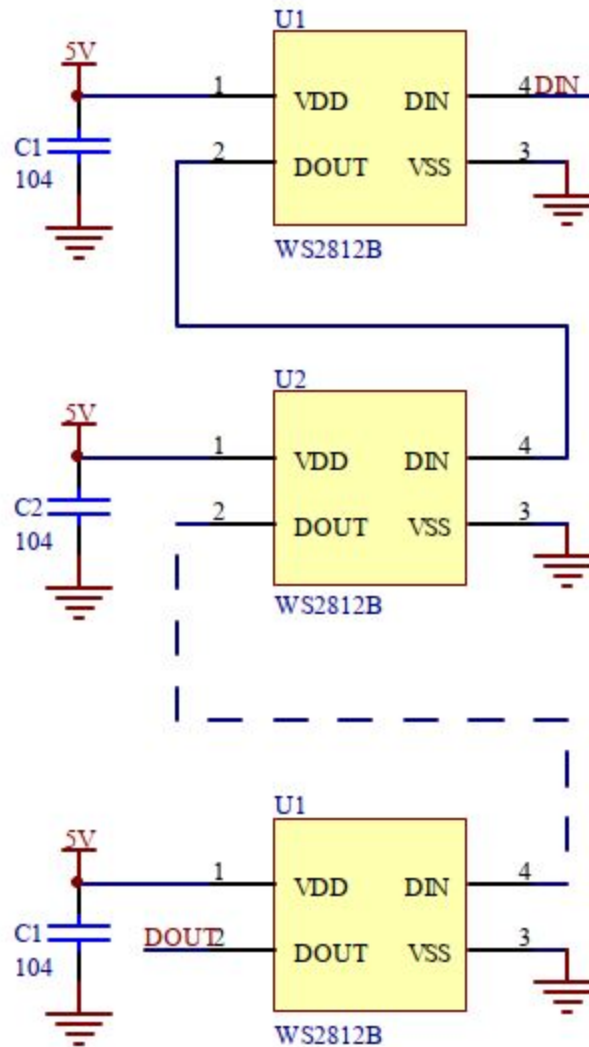

### 4.3. Structure Design

This structure is going to be a 1 ft. by 1 ft. block. The reason for the size is to help with installation and design. Walkways are typically 3 ft. wide per code; therefore this device could meet code without needing to be resized. The top of the structure will be pavers, and the sides / bottom of the structure will be wood. All cracks will be sealed to ensure there isn't any water intrusion that could damage the electronics or rot out the wood.

### 4.3.1. Top of Structure Design

The images below are an updated version of the top view of the structure once actual dimensions were chosen.

**Figure 41** - Top View of Structure with descriptions

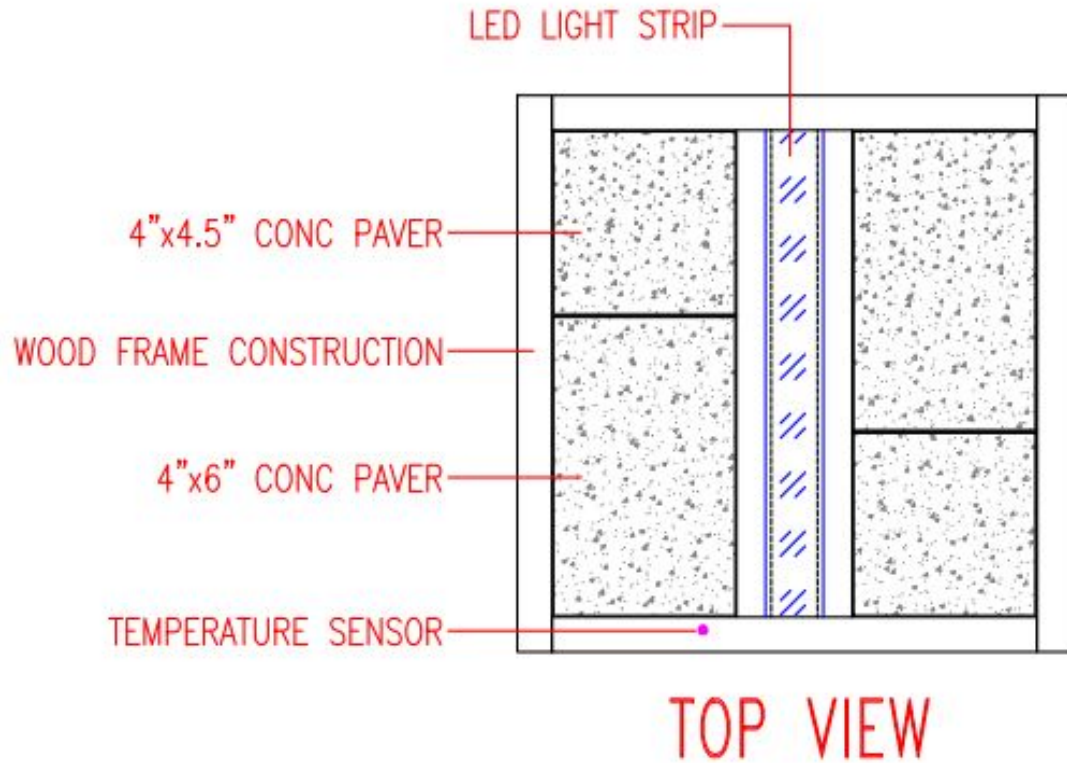

**Figure 42** - Top View of Structure with dimensions

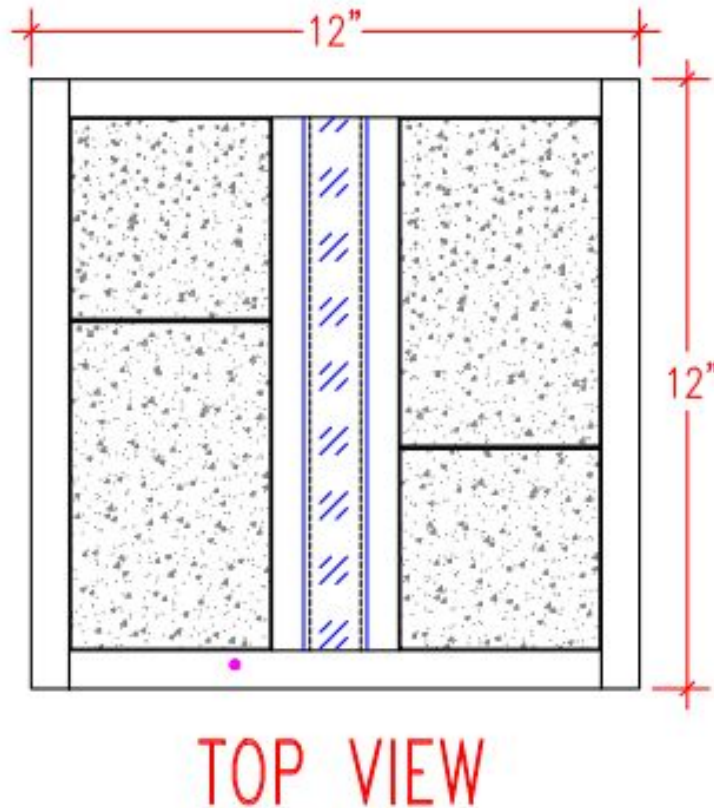

The top of this structure will consist of two main parts: the plexiglass overtop of the LED, and a paver laying on top of a paver base of concrete fines. The plexiglass is going to be ordered to size. The dimensions for the plexiglass will be 10 and  $\frac{3}{4}$  inches long, 1 and  $\frac{1}{4}$  inches wide, and  $\frac{1}{8}$  inch thick. The reason for the extra quarter inch on each side is so that we can make it flush with wood that will be holding it up. We will carve out a  $\frac{1}{8}$  inch x  $\frac{1}{8}$  inch piece out of the top corner of the wood on all four sides so that the plexiglass will lay flush. Then, using a two part epoxy the plexiglass will be glued to the wood. For the concrete pavers, we have decided to use a thinner paver for this project. The main reason for this is so that the heating element will not have to heat up as much compared to using a normal sized paver. There will be two different lengths of pavers that we will use, but they will both have the same width and thickness. The width for each paver will be 3 and  $\frac{7}{8}$  inches, and the thickness will be 1 and  $\frac{1}{4}$  inches. The two lengths will be 5 and  $\frac{7}{8}$  inches and 3 and  $\frac{7}{8}$  inches. The reason for  $\frac{7}{8}$  inches on both the width and the length rather than rounding up to the nearest value is because in between each paver there will be roughly  $\frac{1}{4}$  inch of sand to ensure that it does not shift once it has been set. This strategy is commonplace when using pavers. Underneath the pavers, there will be roughly 1 and  $\frac{3}{4}$  inches of concrete fines that the pavers will lay on. In the middle of the concrete fines will be where the heating element will exist. The reason that the concrete fines

have to be on top of the heating element rather than having the heating element directly underneath the paver is that the paver is a solid material that is prone to shifting. If it shifts too much, not only is it unsafe for anyone walking on it, but it could also damage the heating element.

There are a couple of other small products that will be needed for the top of the structure as well. Those are a wood sealant (which will be discussed in further detail in the “Bottom of Structure Design” section) and a water sealant. The water sealant will be installed in every crack at the top of this product: every wood to wood crack, every wood to paver crack, every paver to paver crack, and the crack between the wood and the plexiglass. The water sealant will also be installed at the wood cracks in the middle and bottom of the structure to ensure that the electronics in the cavity of the structure do not get wet. The wood sealant that will be used is DAP DYNAFLEX 230. This product is 100% waterproof. It has the performance characteristics of silicone such as durability, adhesion and flexibility, and it also has the easy tooling, paintability, and low odor of latex sealant. Simply put, it is the best of both worlds for a water sealant. Also, this material is very temperature resistant as it is rated for temperatures as low as -30 degrees F and as high as 180 degrees F, perfect for this exterior rated project.

### 4.3.2. Bottom of Structure Design

The images below are an updated version of the side view of the structure once actual dimensions were chosen.

**Figure 43** - Side View of Structure with Descriptions

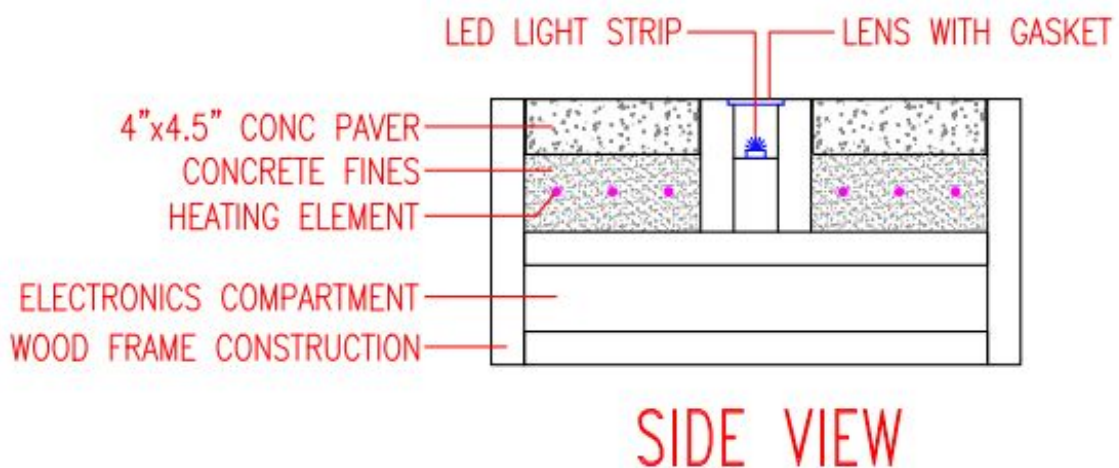



**Figure 44** - Side View of Structure with Dimensions

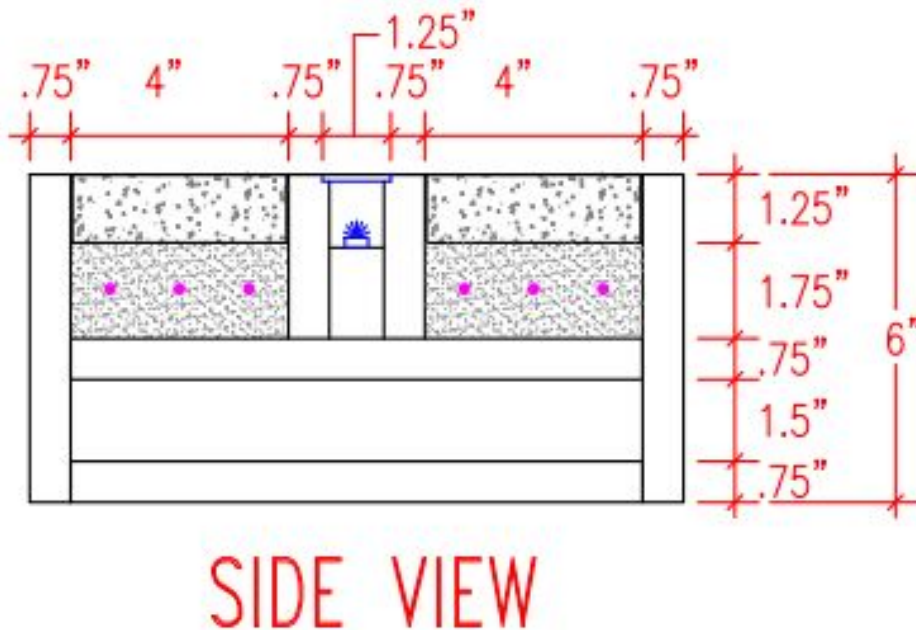

The bottom of this structure will consist primarily of wood. The type of wood that will be used is cedar wood. There are quite a few reasons why cedar wood is what has been chosen for this project. First off, cedar wood is readily available at most home improvement stores so it will not be something that has a long lead time and is difficult to acquire. Second, cedar wood comes in multiple different sizes. Most importantly, Cedar comes in the exact thickness and width that we need. The majority of thickness that will be used for this project is  $\frac{3}{4}$  inches. The exterior, the wood casing of the LED, the bottom of the paver base, and the bottom of the electronics cavity will all be  $\frac{3}{4}$  inches thick. That is important because it is hard to cut the thickness or width of a wood board. Cutting the length is simple, so the length that the board comes in does not matter as much. As was mentioned in the section above, all cracks and crevices will be sealed with a water sealant, even at the bottom of the structure. Also, the entire structure will be coated with a polyurethane sealant. This will be to prevent weathering, rotting, and discoloration throughout the life of the product.

## 5. Prototype and Testing

The following subsections will outline how the smart tile system will be prototyped and the functionality tested to match the most common use cases and environments. This section will be split into different subsections based on the hardware or software component. Each subsection will outline their respective component's testing routine and why it is important to test that feature or function for the final product.

## 5.1 Software Standards and Testing Procedures

The software testing cycle will most likely follow conventional software unit and revision testing cycles, where the code is written and stored in a third party source code management application, either github or bitbucket. Both the microcontroller and the phone's code will be stored in a repository to ensure redundant and safe backups of the code. It also allows the code to be accessible from anywhere so that it is decentralized and not prone to a memory failure happening where all the code could be lost.

Unit Testing will be the main method of testing the code for both the microcontroller and the mobile application. Unit testing will allow for each function to be tested against the expected input and allow for the output to be measured against the expected result. Unit testing also allows for problem areas within the code to be isolated so that they can be handled and fixed without disrupting any other working functionality.

### 5.1.1 Microcontroller Testing

There are multiple unique aspects of the microcontroller's functionality that need to be tested. The biggest ticket item is the code for the logic that controls the heating element and LEDs. Connection to a Wi-Fi network will be able to be tested by simply connecting to a home network. Each function will be tested through unit testing. Each function will be sent inputs such as temperature sensor data, humidity sensor data, and expected API requests from the phone application's side that are mocked to replicate an actual input.

The functions that have outputs that affect the physical hardware will have to be tested similarly to the Wi-Fi connection, where the measurement of success is based on how the hardware reacts. This includes the heating element and the LEDs. The heating element will be a simple on/off bit input to the data port that the heating element is connected to. For the LEDs, the output would include an on/off bit and the data that affects the color of the LED strip.

**Figure 45** - Microcontroller Testing Plan

<b>Test</b>	Microcontroller Logic Unit Testing
<b>Purpose</b>	To ensure that the logic functions controlling the heating element and LEDs function correctly given the expected inputs.
<b>Test Materials</b>	<ul style="list-style-type: none"><li>• Test that the microcontroller can receive inputs from the</li></ul>

	<p>temperature sensor</p> <ul style="list-style-type: none"> <li>● Test that the microcontroller can send outputs to the LEDs</li> <li>● Test that the microcontroller can receive inputs from the humidity sensor</li> <li>● Test that the microcontroller can connect to the Wi-Fi network or act as a Wi-Fi hub</li> <li>● Test the function that, with the given inputs, the microcontroller will correctly turn on the heating element</li> <li>● Test that the microcontroller will be able to receive data from the mobile application</li> <li>● Test that the microcontroller will be able to send data to the mobile application</li> </ul>
<b>Prerequisites</b>	Logic functions that provide the functionality are written
<b>Procedure</b>	<ol style="list-style-type: none"> <li>1. Unit tests will be written to mock the data that the logic functions will be expecting to receive. This will give a basis by which the live data will be compared to in order to see if the sensors are behaving correctly</li> <li>2. Mock requests will be made to the functions that receive and send data for the mobile application to ensure that the functions that handle this data are behaving correctly</li> <li>3. Try connecting to a known Wi-Fi network to ensure that the microcontroller's Wi-Fi module works correctly</li> </ol>
<b>Results Expected</b>	The results expected should match those given by the live data coming

	from the sensors and mobile application requests.
--	---

## 5.1.2 Phone Application Testing

The phone application will require multiple different types of testing. Unit testing will be used similarly to the microcontroller for functions on the backend. Each function will be sent an input that replicates the data that would be retrieved from the microcontroller. This includes temperature and humidity sensor data, battery level data, LED status and color, and Wi-Fi connection status. This kind of testing is to make sure that the functions that take in this data provide the right outputs so that the user interface would display accurate information that would influence how the user interacts with the device.

The internal functions on the backend that perform simple operations will have their own specific unit tests. This includes calculations that need to be made based on the sensor and battery level data. Functions that manage user inputs from the user interface will also have unit tests to ensure that the toggle buttons and color selector are sending the correct data.

The API that the system will use, which will be located within the mobile application's codebase, will be tested with mock data to see if the requests are valid requests that can be parsed by the microcontroller. The API will be the main form of communication between the two devices so it is paramount that the inputs and outputs match the expected values. The biggest challenge with testing and prototyping the API will be finding the right way to format the data so that the microcontroller can read the inputs from the mobile application.

The Graphical User Interface (GUI) is markedly the most important aspect of the testing. If the GUI has nonfunctional items or has issues displaying the buttons and information between devices or resolutions it will greatly reduce the marketability. As decided, the backend of the mobile application will be written in Python through the Kivy framework. The Kivy framework allows the GUI to be tested on a multitude of platforms and devices, including Android, iOS, GNU/Linux, OS X, and Windows, although only Android and iOS will be the focus to not waste extra resources on platforms that have a small user base.

**Figure 46** - Mobile Application Testing Plan

<b>Test</b>	Mobile Application Unit and GUI testing
<b>Purpose</b>	<ul style="list-style-type: none"> <li>● Test that the functions on the backend of the mobile application behave correctly when given the expected inputs and outputs</li> <li>● Test that the inputs the user is able to make send data to the backend</li> <li>● Test that the GUI works on the most common devices and resolutions</li> </ul>
<b>Prerequisites</b>	Logic functions that provide functionality are written. The GUI must also be finished and have functions that correlate to the buttons and toggle inputs
<b>Procedure</b>	<ol style="list-style-type: none"> <li>1. Unit tests will be written to ensure that the functions on the backend behave correctly when receiving the expected inputs</li> <li>2. Mock requests will be made to the functions that receive and send data for the microcontroller to ensure that the functions that handle this data are behaving correctly</li> <li>3. The mobile application will be run on the most common devices (Android, iOS) and the most common resolutions to ensure that the frontend looks correct</li> </ol>
<b>Results Expected</b>	The mobile application will be able to receive inputs from the user on the most common devices and send the correct outputs to the microcontroller. The frontend will behave the same across device platforms

## 5.1.3 Communications Testing

Communication between the microcontroller and mobile application will be tested first by making sure a connection can be established. If the microcontroller can connect to a home network through the embedded Wi-Fi module then that is a success. If the phone application is able to join the same network then that would be a success. If the microcontroller and the mobile application can recognize the other and communicate with each other through the network then that is a big success. If all three of those steps can be replicated on multiple types of networks, all with successes, then the communications between the microcontroller will have been successfully tested.

**Figure 47** - Communications Testing Plan

<b>Test</b>	Communication Wi-Fi test
<b>Purpose</b>	Communication between microcontroller and mobile application is established
<b>Test Materials</b>	<ul style="list-style-type: none"> <li>● Microcontroller</li> <li>● Phone</li> <li>● Mobile Application</li> <li>● Wi-Fi Connection Available</li> </ul>
<b>Prerequisites</b>	The microcontroller and phone must be connected to the same Wi-Fi network. The mobile application and microcontroller's backend must be written out to send and receive data
<b>Procedure</b>	<ol style="list-style-type: none"> <li>1. Connect the Microcontroller to the Wi-Fi network</li> <li>2. Connect the Phone to the same Wi-Fi network</li> <li>3. Test that the microcontroller can send and receive data through the network</li> <li>4. Test that the mobile application can send and receive data through the network</li> <li>5. Test that the two devices can communicate with each other</li> </ol>
<b>Results Expected</b>	The microcontroller and mobile application should be able to send and

	receive data from each other through the Wi-Fi network.
--	---

## 5.2 Hardware Testing

Testing the hardware for this project entails anything electronically that will contribute to the project: the power system, the sensors, the heating element, and the lighting strip. The thing that makes all of this work though is the PCB board. For this section, we will discuss how to test the parts that will be integrated onto the PCB board before building the board (aka testing on a breadboard). Figure 45 below is a detailed table of how we will accomplish this.

**Figure 48** - Hardware Testing Plan

<b>Test</b>	Hardware Breadboard Test
<b>Purpose</b>	To ensure that the electronics work as designed prior to printing and soldering all of the chips, resistors, and capacitors onto the PCB
<b>Test Materials</b>	<ul style="list-style-type: none"> <li>● Multimeter / Voltage Meter</li> <li>● Breadboard</li> <li>● Connection wires</li> <li>● AC/DC Converter</li> <li>● DC/DC Converter</li> <li>● Resistors and Capacitors for converters as needed per the datasheets.</li> <li>● Relay</li> <li>● Arduino</li> </ul>
<b>Prerequisites</b>	Design the schematic and ensure mathematical equations are completed to determine resistor and capacitor values for DC/DC converter. Also, the code for turning on and off the relay for the heating system needs to be written.
<b>Procedure</b>	<ol style="list-style-type: none"> <li>1. Connect AC/DC converter as well as the 120V power source</li> <li>2. Measure the output of the AC/DC converter with a voltage meter to ensure 5V is measured as needed.</li> <li>3. Connect the DC/DC converter and all parts necessary as designed.</li> <li>4. Measure the output of the DC/DC converter with the voltage meter to ensure 3.3V is</li> </ol>

	<p>measured as needed.</p> <p>5. Connect the relay to the 120V source as well as the Arduino as specified.</p> <p>6. Ensure that the output of the relay measures 120V when the Arduino turns it on, and ensure that no voltage is measured when it is turned off.</p>
<b>Results Expected</b>	<p>All voltages and measurements should be accurate per the design. The main 3 points to measure are:</p> <ul style="list-style-type: none"> <li>● 5V at the output of the AC/DC converter.</li> <li>● 3.3V at the output of the DC/DC converter.</li> <li>● 120V at the output of the relay when it is turned on and 0V when it is turned off.</li> </ul>

## 5.2.1 Power Testing

Having a safe way to diagnose and test the Tiles and all subsystems of the Tile Product will need to be understood fully before attempting any repairs or replacement. Mostly all the components that will be used in the Tile systems will for the most part be serviceable by the end user, doing this will increase the lifespan, and overall value and quality of the product.

**Figure 49** - Power Testing Plan

<b>Test</b>	Power Testing and Troubleshooting
<b>Purpose</b>	To ensure that the electronics work as designed after components are mounted, or Power issues occur.
<b>Test Materials</b>	<ul style="list-style-type: none"> <li>● Multimeter / Voltage Meter</li> <li>● Connection wires</li> <li>● AC/DC Converter</li> <li>● DC/DC Converter</li> <li>● Resistors and Capacitors for converters as needed per the datasheets.</li> <li>● Relay</li> <li>● MicroController</li> <li>● Temperature Sensor</li> <li>● Humidity Sensor</li> <li>● LEDs</li> <li>● PCB Traces, Wires and Connectors</li> <li>● Battery and Solar Setup/Configuration</li> </ul>



<p><b>Prerequisites</b></p>	<p>Ensure that the Circuit breaker, and outlet are in working order before beginning to troubleshoot Tile System.</p> <p>If Circuit breaker and Outlet are working, and the Tile system does not turn on then continue the continuity test to ensure no shorts, or open circuits are occurring.</p>
<p><b>Continuity Test: Relay</b></p>	<p><b>CAUTION: REMOVE ELECTRICAL PLUG FROM OUTLET BEFORE BEGINNING THE CONTINUITY TEST.</b></p> <p><b>Procedure: Move to the next step once completed previous step, do not skip steps. Replace component if not within range.</b></p> <ol style="list-style-type: none"> <li>1. Using the Multimeter, set to continuity test.</li> <li>2. Remove relay from socket and test control side coil for continuity rated for (x Ohms).</li> <li>3. Test switching side for open circuit.</li> <li>4. Apply 5v to control side and ground to control side, to allow current flow through the coil. You should hear the relay “click”</li> <li>5. If values are within range, and you hear no click, replace relay and test again.</li> <li>6. If Values are not within range, replace relay and test again.</li> </ol>
<p><b>Continuity Test: Humidity Sensor/</b></p>	<p><b>CAUTION: REMOVE ELECTRICAL PLUG FROM OUTLET BEFORE BEGINNING THE CONTINUITY TEST.</b></p> <p><b>Procedure: Move to the next step once completed previous step, do not skip steps. Replace component if not within range.</b></p> <ol style="list-style-type: none"> <li>1. Using the Multimeter, set to continuity test.</li> <li>2. Unplug the Humidity Sensor from the electrical connection.</li> <li>3. Check the internal resistance of the sensor for continuity rated for (x Ohms).</li> <li>4. If Values are not within range, replace Sensor and test again.</li> </ol>

<p><b>Continuity Test: Temperature Sensor</b></p>	<p><b>CAUTION: REMOVE ELECTRICAL PLUG FROM OUTLET BEFORE BEGINNING THE CONTINUITY TEST.</b></p> <p><b>Procedure: Move to the next step once completed previous step, do not skip steps. Replace component if not within range.</b></p> <ol style="list-style-type: none"> <li>1. Using the Multimeter, set to continuity test.</li> <li>2. Unplug the Temperature Sensor from the electrical connection.</li> <li>3. Check the internal resistance of the sensor for continuity rated for (x Ohms).</li> <li>4. If Values are not within range, replace Sensor and test again.</li> </ol>
<p><b>Continuity Test: Wires and Traces.</b></p>	<p><b>CAUTION: REMOVE ELECTRICAL PLUG FROM OUTLET BEFORE BEGINNING THE CONTINUITY TEST.</b></p> <p><b>Procedure: Move to the next step once completed previous step, do not skip steps. Replace component if not within range.</b></p> <ol style="list-style-type: none"> <li>1. Using the Multimeter, set to continuity test.</li> <li>2. Follow the schematic and check continuity of all traces.</li> <li>3. Any connectors should be checked for continuity of connector pins to external to internal.</li> <li>4. All wires should be checked for continuity from connector end to wire end to ensure proper crimp, solder and connectivity.</li> </ol>
<p><b>Power Troubleshooting:</b></p>	<p><b>CAUTION: HIGH VOLTAGE. SYSTEM ON, &amp; PLUGGED INTO LIVE OUTLET.</b></p> <p>If any components are not producing the correct voltage, replace the component.</p> <ol style="list-style-type: none"> <li>1. Set Voltmeter to check AC Voltage.</li> <li>2. Probe AC/DC convertor, AC side should read 110-120V</li> <li>3. Set Voltmeter to check DC Voltage</li> </ol>

	<ol style="list-style-type: none"> <li>4. Probe AC/DC convertor, DC side should read 110-120 VDC.</li> <li>5. Probe DC/DC Convertor</li> <li>6. Primary Side should read 110 -120V DC</li> <li>7. Secondary side should read 5V DC</li> <li>8. Probe sensor(s) voltage should vary within range of 0-5V DC</li> <li>9. Probe LED, Voltage should be within working range of 5V DC.</li> <li>10. Probe Output control pin of Microcontroller to relay, Voltage should be 5v DC when conditions are met.</li> <li>11. Probe input pin of relay for control side, Voltage should be 5v DC when conditions are met.</li> </ol>
--	--

## 5.2.2 Sensor Testing

The data provided from the sensors is very important and having operational accurate sensors is an integral part of this project, in this section the process of testing these sensors will be discussed along with functionality of each sensor in the project. In order to troubleshoot these sensors it is important to understand how each test works, and determine if the connection was faulty or if the sensor itself is not functioning as it should.

### 5.2.2.1 Temperature Sensor Testing

The temperature sensor is one of the most important sensors in the project, it will provide the surface temperature of the tile at all times. The first test that will be performed on the temperature sensor to verify that this sensor is calibrated and working properly is building a simple circuit. Figure 46 from [59] shows the initial test configuration. Figure 47 shows the purpose of the test, the materials necessary to perform the test, along with the steps and expected results.

**Figure 50** - Temperature Sensor Testing Circuit - Permission Received

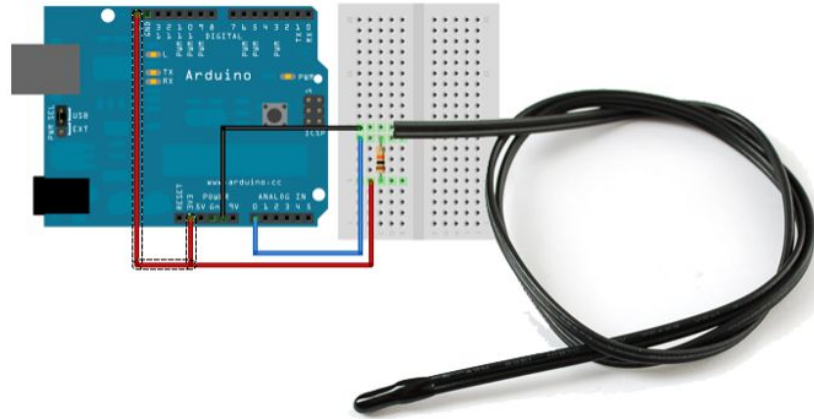

**Figure 51** - Initial Temperature Sensor Testing Plan

<b>Test</b>	Initial Temperature Sensor Test
<b>Purpose</b>	<ul style="list-style-type: none"> <li>• Ensure that the Temperature Sensor turns on.</li> <li>• Ensure that the data provided is accurate</li> <li>• Ensure that the Temperature data will change accordingly with the environment</li> </ul>
<b>Test Materials</b>	<ul style="list-style-type: none"> <li>• NTC 10k Thermistor</li> <li>• Arduino</li> <li>• 120VAC to 3.3VDC or 5VDC converter</li> <li>• Power supply</li> <li>• 10kΩ resistor</li> <li>• Breadboard</li> <li>• Connection wires</li> </ul>
<b>Prerequisites</b>	<ul style="list-style-type: none"> <li>• Ensure that the AC to DC converter is outputting 3.3-5V to avoid frying both the Arduino and Sensor</li> <li>• Have code written to be able to interface the temperature sensor to the Arduino</li> </ul>

<b>Procedure</b>	<ol style="list-style-type: none"> <li>1. Load code into the arduino.</li> <li>2. Connect all devices as shown in the schematic diagram.</li> <li>3. Open Terminal on PC running the code</li> <li>4. Ensure baud rate is set correctly</li> <li>5. Ensure temperature data is accurate by comparing data to actual temperature data from infrared thermostat or other accurate temperature sensors</li> </ol>
<b>Results Expected</b>	The Temperature sensor data from the NTC 10k Thermistor matches the data provided from a known good thermostat or temperature sensor.

The next test that will be performed with the temperature sensor is to integrate the thermistor into the prototype circuit and power it on. When power is applied the temperature sensor should provide temperature data to the Arduino at all times. Next the temperature can be increased or decreased by modifying the environment around it, when modifying the environment the temperature should change accordingly. Figure 49 below shows the purpose of this test, the materials necessary along with the prerequisites, test procedure and expected results of this test.

**Figure 52** - Prototype Circuit Temperature Sensor Test

<b>Test</b>	Prototype Circuit Temperature Sensor Test
<b>Purpose</b>	<ul style="list-style-type: none"> <li>• Ensure that the Temperature Sensor turns on.</li> <li>• Ensure that the data provided is accurate</li> <li>• Ensure that the Temperature data will change accordingly with the environment</li> </ul>

<b>Test Materials</b>	<ul style="list-style-type: none"> <li>● NTC 10k Thermistor</li> <li>● Arduino</li> <li>● 120VAC to 3.3VDC or 5VDC converter</li> <li>● Power supply</li> <li>● 10kΩ resistor</li> <li>● Breadboard</li> <li>● Connection wires</li> </ul>
<b>Prerequisites</b>	<ul style="list-style-type: none"> <li>● Ensure that the AC to DC converter is outputting 3.3-5V to avoid frying both the Arduino and Sensor</li> <li>● Have code written to be able to interface the temperature sensor to the Arduino and the Arduino to the smart phone application</li> </ul>
<b>Procedure</b>	<ol style="list-style-type: none"> <li>1. Load code into the Arduino.</li> <li>2. Connect all devices as shown in the schematic diagram.</li> <li>3. Log into phone app</li> <li>4. Apply power to the prototype circuit</li> <li>5. Ensure that the smartphone application is displaying temperature data</li> <li>6. Compare temperature sensor data to data from a known good temperature sensor or infrared thermostat.</li> </ol>
<b>Results Expected</b>	<p>The Temperature sensor data from the NTC 10k Thermistor matches the data provided from a known good thermostat or temperature sensor.</p>

### 5.2.2.2 Humidity sensor testing

The humidity sensor is another very important component in this project's functionality, it is important to verify that it operates and provides accurate data. The first test for the humidity sensor is similar to the temperature sensor, connecting just the humidity sensor to the Arduino in a simple circuit configuration. Figure 51 below from [60] shows the initial sensor test with just the DHT11 sensor and the Arduino. Figure 51 shows the test name, materials needed, prerequisites, test procedure along with the expected results of this test case.

**Figure 53** - Humidity Sensor Testing Circuit - Permission Requested

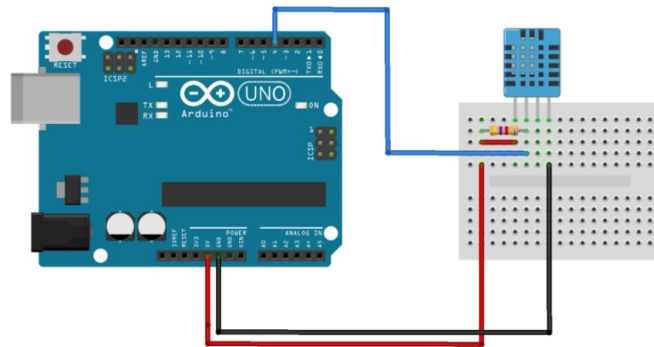

**Figure 54** - Initial Humidity Sensor Testing Plan

<b>Test</b>	Initial Humidity Sensor Test
<b>Purpose</b>	<ul style="list-style-type: none"> <li>• Ensure that the Humidity sensor turns on.</li> <li>• Ensure that the data provided is accurate</li> <li>• Ensure that the humidity will change accordingly with the environment</li> </ul>
<b>Test Materials</b>	<ul style="list-style-type: none"> <li>• DHT11 Humidity Sensor</li> <li>• Arduino</li> <li>• 120VAC to 5VDC converter</li> <li>• Power supply</li> <li>• 1k-10kΩ resistor</li> <li>• Breadboard</li> <li>• Connection wires</li> </ul>
<b>Prerequisites</b>	<ul style="list-style-type: none"> <li>• Ensure that the AC to DC converter is outputting 5V to avoid frying both the Arduino and Sensor</li> </ul>

	<ul style="list-style-type: none"> <li>• Have code written to be able to interface the Humidity sensor to the Arduino</li> </ul>
<b>Procedure</b>	<ol style="list-style-type: none"> <li>1. Load code into the arduino.</li> <li>2. Connect all devices as shown in the schematic diagram.</li> <li>3. Open Terminal on PC running the code</li> <li>4. Ensure baud rate is set correctly</li> <li>5. Ensure humidity data is accurate by comparing data to actual humidity data from known good humidity sensor</li> </ol>
<b>Results Expected</b>	The humidity sensor data from DHT11 humidity sensor matches the data provided from a known good humidity sensor.

The next test for the humidity sensor is integrating the humidity sensor into the prototype circuit with all the systems connected and powering it up, when powered up the humidity sensor will provide accurate relative air temperature and humidity data to the Arduino at all times. Next a spray bottle can be used to simulate weather conditions with more humidity, when the spray bottle is misted near the humidity sensor the data provided should reflect a higher humidity percentage. Figure 52 below displays the test purpose, prerequisites, test procedure and the expected results.

**Figure 55** - Prototype Circuit Humidity Sensor Test

<b>Test</b>	Prototype Circuit Humidity Sensor Test
<b>Purpose</b>	<ul style="list-style-type: none"> <li>• Ensure that the Humidity sensor turns on.</li> <li>• Ensure that the data provided is accurate</li> <li>• Ensure that the humidity will change accordingly with the environment</li> </ul>



<b>Test Materials</b>	<ul style="list-style-type: none"> <li>● DHT11 Humidity Sensor</li> <li>● Arduino</li> <li>● 120VAC to 5VDC converter</li> <li>● Power supply</li> <li>● 1k-10kΩ resistor</li> <li>● Breadboard</li> <li>● Connection wires</li> </ul>
<b>Prerequisites</b>	<ul style="list-style-type: none"> <li>● Ensure that the AC to DC converter is outputting 5V to avoid frying both the Arduino and Sensor</li> <li>● Have code written to be able to interface the Humidity sensor to the Arduino and Arduino to the smart phone application.</li> </ul>
<b>Procedure</b>	<ol style="list-style-type: none"> <li>1. Load code into the Arduino.</li> <li>2. Connect all devices as shown in the schematic diagram.</li> <li>3. Log into phone app</li> <li>4. Apply power to the prototype circuit</li> <li>5. Ensure that the smartphone application is displaying humidity data</li> <li>6. Compare humidity sensor data to data from a known good sensor</li> <li>7. Mist near the humidity sensor, ensure that the data is changing accordingly.</li> </ol>
<b>Results Expected</b>	<p>The humidity sensor data from DHT11 humidity sensor matches the data provided from a known good humidity sensor and changes accordingly when moisture is added to the environment.</p>

### 5.2.3 Heating system testing

The heating system of this project is the most important system, the heating system relies on temperature and humidity data along with power from a relay to power on and off. This can be tested by changing the tolerances of the sensor data in the code to feasible conditions and seeing if the relay engages power to the system. Figure 53 below shows the test case, purpose of this test, prerequisites, test procedure along with the expected results.

**Figure 56** - Heating System Sensor Test

<b>Test</b>	Heating system Sensors test
<b>Purpose</b>	<ul style="list-style-type: none"><li>• Ensure that the heating system turns on when temperature and humidity data hit a certain value</li><li>• Ensure that the heating system turns off when the specified temperature and humidity values are reached</li></ul>
<b>Test Materials</b>	<ul style="list-style-type: none"><li>• Heating cable</li><li>• Relays</li><li>• DHT11 Humidity Sensor</li><li>• NTC 10k Thermistor</li><li>• Arduino</li><li>• 120VAC to 5VDC converter</li><li>• Power supply</li><li>• 1k-10k<math>\Omega</math> resistor</li><li>• Breadboard</li><li>• Connection wires</li></ul>
<b>Prerequisites</b>	<ul style="list-style-type: none"><li>• Ensure that the AC to DC converter is outputting 5V to avoid frying both the Arduino and Sensors</li><li>• Have code written to be able to interface the Humidity sensor to the Arduino</li></ul>

<b>Procedure</b>	<ol style="list-style-type: none"> <li>1. Load code into the Arduino with altered tolerances for the temperature and humidity sensor to force the heating system on.</li> <li>2. Connect all devices as shown in the schematic diagram.</li> <li>3. Log into phone app</li> <li>4. Apply power to the prototype circuit</li> <li>5. Ensure that the smartphone application is displaying all sensor data and heating system status.</li> <li>6. Ensure that the heating system turns on</li> </ol>
<b>Results Expected</b>	The heating system turns on with the altered tolerances, heats up to a certain specified value and turns off at this value.

Another test for this system is to disconnect the heating cables from the relay and plug it directly into the wall outlet. When plugged into the wall outlet power should be applied to the heating cables and the cables should start to get warm. Another way to verify that the heating cable is getting sufficient power is to use a clamp style AC current sensor around the cable and ensure that the current passing through the cable is equivalent to the current provided on the datasheet for this cable. With the current measurement and the known resistance of 28.8 ohms, ohms law can be used to get a measurement of the voltage. The voltage and current can then be used to calculate the power being provided with the equation  $P = IV$  or  $P = I^2R$ . Figure 54 below shows this test case, the materials needed, the prerequisites, the test procedure and the expected test results.

**Figure 57** - Heating System Cable Test

<b>Test</b>	Heating system cable test
<b>Purpose</b>	<ul style="list-style-type: none"> <li>• Ensure that the heating system turns on when plugged into the wall outlet.</li> <li>• Ensure that the heating system is supplying sufficient power</li> </ul>
<b>Test Materials</b>	<ul style="list-style-type: none"> <li>• Heating cable</li> <li>• Ammeter, Current sensor clamp</li> </ul>

<b>Prerequisites</b>	<ul style="list-style-type: none"> <li>• Make sure the wall outlet is a known good wall outlet</li> </ul>
<b>Procedure</b>	<ol style="list-style-type: none"> <li>1. Plug the heating cable directly into the wall outlet</li> <li>2. Wrap the ammeter clamp around the heating cable</li> <li>3. Record the data obtained from the ammeter</li> <li>4. Use the equation <math>P=i^2R</math> with the resistance value of 28.8 ohms</li> <li>5. Compare the calculated power to the datasheet</li> </ol>
<b>Results Expected</b>	The heating system turns on when plugged in and supplies sufficient power when measured with the ammeter

sensor around the cable and ensure that the current passing through the cable is equivalent to the current provided on the datasheet for this cable. With the current measurement and the known resistance of 28.8 ohms, ohms law can be used to get a measurement of the voltage. The voltage and current can then be used to calculate the power being provided with the equation  $P = VI$  or  $P = i^2R$ .

## 5.2.4 Lighting Testing

The lighting testing for this project is very important. The WS2812B LED strip that is being used cannot be controlled from an external device. It must be controlled via an MCU. Therefore it is imperative that this is deemed working before installing the project. There are two figures below. Figure 55 is a table to describe the testing purpose, materials, prerequisites, procedure, and expected results. Figure 55 underneath the table is a design of the testing connections that will need to be made to the arduino. [58]

**Figure 58** - Table to Describe Lighting Testing

<b>Test</b>	LED Lighting Strip Test
<b>Purpose</b>	<ul style="list-style-type: none"> <li>• Ensure that the LED's turn on.</li> <li>• Ensure that each LED is individually addressable.</li> <li>• Ensure the LED's will change color.</li> <li>• Ensure the LED's will dim.</li> </ul>

<b>Test Materials</b>	<ul style="list-style-type: none"> <li>● WS2812B LED light strip</li> <li>● Arduino</li> <li>● 120VAC to 5VDC converter</li> <li>● Power supply</li> <li>● 330Ω resistor</li> <li>● 100μF capacitor</li> <li>● Breadboard</li> <li>● Connection wires</li> </ul>
<b>Prerequisites</b>	<ul style="list-style-type: none"> <li>● Ensure that the AC to DC converter is outputting 5V to avoid frying both the Arduino and the LED strip.</li> <li>● Have code written to be able to control LED strips from a phone app (address each LED, color change each LED, dim each LED).</li> </ul>
<b>Procedure</b>	<ol style="list-style-type: none"> <li>1. Load code into the arduino.</li> <li>2. Connect all devices as shown in the schematic diagram.</li> <li>3. Log into phone app</li> <li>4. Test to turn lights on</li> <li>5. Test to control each LED individually</li> <li>6. Test color scheme.</li> <li>7. Test timeclock functionality of the LED.</li> </ol>
<b>Results Expected</b>	<p>The LED strip should be vibrant and full of every color that it can create. There are many goals with this LED strip that contribute to the results we will expect:</p> <ol style="list-style-type: none"> <li>1. Use this as a light to illuminate a walkway at night</li> <li>2. Have the ability to set timeclock settings so that the light can turn on and off per the end users needs and wants.</li> <li>3. Change colors for special events or seasons (orange for Halloween, red white and blue for July 4th, red and green for Christmas, blue and pink for a baby shower, etc.)</li> </ol>

**Figure 59** - Testing hardware design for LED (Permission received from ElectronicsHub.org to post) [58]

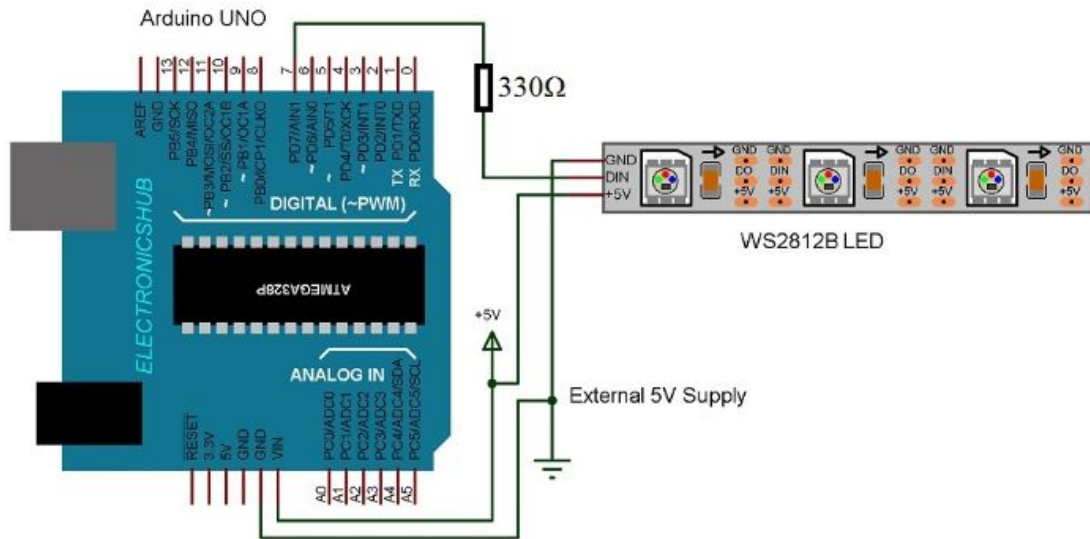

## 6. Administrative Content

Planning is always one of the most underappreciated parts of a project like this, and it is easy to overlook the importance of it. When a project has a deadline, it must be broken into multiple achievable goals along the way. There are two reasons for this. First off, and this is less likely to happen, one could over-stress about completing the project on time and end up overworking themselves to complete it with plenty of time to spare. That does not sound too bad, but there are things that could go wrong. For instance, if a design project is rushed, it may not be done to the best of the designers abilities. Typically there are three parts to any design project and only two will be chosen: Good, Cheap, and Fast. If a project is rushed, usually either the quality or the price will suffer. It is rare to complete a project fast, with perfect quality, and at the maximized cost effectiveness. The other scenario that is more likely if planning does not take place is procrastination. This occurs when the team says things like, "We have plenty of time to design this. We will figure it out later." That is fine when there are 7-8 months until a project is due, but if this is still being said 1-2 months before it is due then that is a problem. When a project like this is planned correctly, it can basically take away the fast factor. If there are multiple, small, attainable goals throughout the project that build towards the betterment of the entire design, then it doesn't necessarily have to be done fast, but just good and cost effective. With all of that being said, below is our milestone chart as well as the budget for this project. We want to plan to ensure that the deadlines are met, and we want to ensure that by the end of the project we are not blindsided by a total cost that is greater than we expected to pay

## 6.1. Project Milestones

Below is a breakdown of the different milestones that must be hit for this project. Some of these milestones are self imposed to stay on track while others are dates provided by the department. This has been broken down by task, timeframe, and the current status of each.

**Figure 60** - Project Milestones

Number	Task	Start Date	End Date	Status
<b>Senior Design 1</b>				
1	Project Selection	5/13/2020	5/19/2020	Completed
2	Initial Project Documentation (Divide & Conquer)	5/19/2020	5/29/2020	Completed
3	Initial Project Documentation (Divide & Conquer) Update	6/2/2020	6/5/2020	Completed
4	Develop Table of Contents	6/2/2020	6/12/2020	Completed
5	60 Page Draft	6/2/2020	7/3/2020	Completed
6	100 Page Report Submission	6/2/2020	7/17/2020	Completed
7	Final Document	6/2/2020	7/28/2020	Completed
<b>Senior Design 2</b>				
8	Build Prototype	8/24/2020	TBD	Planning
9	Testing	TBD	TBD	
10	Redesign	TBD	TBD	
11	Testing	TBD	TBD	
12	Finalize	TBD	TBD	
13	Peer Presentation	TBD	TBD	
14	Final Report	TBD	TBD	
15	Final Presentation	TBD	TBD	

## 6.2. Budget

Below is the planned budget for this project. This has been broken down by each item, the cost for that item, the total quantity needed for each item, the total for each item, and then the grand total of the entire project.

**Figure 61** - Project Budget

Estimated Project Budget and Financing			
Description	Cost per Item	Quantity	Estimated Cost
Solar Panels	\$100.00	1	\$100.00
LED Strip	\$20.00	1	\$20.00
Surface Mount Temperature Sensor (Thermistor)	\$48.00	1	\$48.00
Humidity Sensor	\$1.00	1	\$1.00
Relay	\$11.95	1	\$11.95
Microcontroller (Arduino)	\$70.00	1	\$70.00
Pin header for GPIO (Assortment Pack)	\$8.99	1	\$8.99
Battery	\$100.00	1	\$100.00
AC/DC Converter	\$35.99	1	\$35.99
DC/DC converter	\$15.99	2	\$31.98
Heating Pad	\$40.00	1	\$40.00
Plexiglass Surface	\$15.00	3	\$45.00
Wood for Enclosure (1-in x 6-in x 8-ft) Cedar	\$13.00	3	\$39.00
Polyurethane Sealant	\$35.00	1	\$35.00
Pavers	\$0.56	4	\$2.24
Paver Base	\$0.50	1	\$0.50
PCB	\$20.00	1	\$20.00
Estimated Total Cost:	\$609.65		



## 7. Conclusion

In conclusion, we have decided that designing a smart tile heating system with the previously listed elements is feasible and can be built to meet our requirements. Ideally, the end product will not be too expensive or complicated to set up and installed. We hope that the smart tile heating system will be able to satisfy the end user through automated snow and ice melting and prove to be a reliable and durable product given the expected weather conditions the smart tile heating system is meant to operate in. While the H.E.A.T.<sup>2</sup> may have its own unique constraints that can sometimes make tasks more difficult than it needs to be, it offers quite a few benefits that are economical, and pro environmental.

The H.E.A.T.<sup>2</sup> tile system will include a way to use solar power to generate electricity and store this power in a battery that can be used when conditions are met. It also will offer the benefit of using an electrical outlet to have constant power and reliability when needed the most. The main components of the Tile system will be to use a combination of 2 sensors, one temperature sensor to measure when the temperature is low enough for snow to form, and a humidity sensor to measure the right humidity for snow to form. This combination will allow the H.E.A.T.<sup>2</sup> smart tile system to know exactly when snow will fall and begin the heat warming process. When the right conditions are met, the internal electronics will allow current flow, which will be controlled by a relay to flow into the heating element and warm the surface of the H.E.A.T.<sup>2</sup>. While all of this may happen automatically, the H.E.A.T.<sup>2</sup> system will also incorporate a way for users to know what is going on, at all times by using LEDs. Looking at the user programmed color options, will indicate the status of the Tile system, whether it is warming up (green) , at operating temperature (red) or off (No LED). This information can also be accessed via the application that comes with the smart tile system. The H.E.A.T.<sup>2</sup> will be constructed into a tile like device, that can be modular, square and 1ft x 1 ft. The different layers will work together to help with heat transfer, energy savings and be robust enough for the harsh weather. Alongside helping the internal electrical components that are mounted on the pcb safe from extreme weather and temperature effects. The Electronics will be housed internally and subjected to be in the cold, snow, and rain and will need to be protected, sealed and insulated from all outside interference.

For the software aspects of the project, using a microcontroller that can communicate through Wi-Fi to a mobile application that can be installed on any mobile device will be not only the easiest to implement, but the most user friendly based on how the user will most likely want to manage their system. Wi-Fi is a system that most users of the device are already comfortable with using, so it is only natural that the device will be set up to interact with the user's home Wi-Fi connection.

We hope that the user will find that managing the system through the mobile application will be similar to how many other “smart” devices on the market let the user manage their systems. As long as the user interface that has been mocked up under Design 4.1.2 is reasonable to implement, the user should have no issue finding and selecting their desired options for the smart tile heating system. The LEDs on the tile will give the user the ability to visibly see their respective choices in action through the snow or ice and act as an indicator of the product working as intended.

In summary, the smart tile heating system should allow the end user the comfort of managing their driveway conditions from their phone. The smart tile heating system will give the end user the time and energy that they would have otherwise spent shoveling snow or picking ice out of their driveway back, while also allowing them to turn off the device if the user would like to save energy or let the snow lay by disabling it.

## 8. Appendices

### 8.1 References

[1] Franklyn, Barbara and White, M. Robert and Lyons, W. John “EMC standards and regulations: A brief overview” National institute of standards and technology Boulder, CO May 1992. Accessed July 2020

Available: <https://www.govinfo.gov/content/pkg/GOVPUB-C13-1f770f754c83c95bcd5d338e84d0cb76/pdf/GOVPUB-C13-1f770f754c83c95bcd5d338e84d0cb76.pdf>

[2] Federal Regulations, Electronic code “Federal Communications Commission” FR48697, December 14, 1984. Accessed July 2020

Available: [https://www.ecfr.gov/cgi-bin/text-idx?SID=eb6cdf716b17af5de440dbc7e9319972&mc=true&tpl=/ecfrbrowse/Title47/47cfr15\\_main\\_02.tpl](https://www.ecfr.gov/cgi-bin/text-idx?SID=eb6cdf716b17af5de440dbc7e9319972&mc=true&tpl=/ecfrbrowse/Title47/47cfr15_main_02.tpl)

[3] Spiewak, Erin “C63.4-2014 American National standard for methods of measurement of radio-noise emission from low voltage electrical equipment in the range of 9kHz to 40GHz” June 20,2014. Accessed July 2020

Available: [https://standards.ieee.org/standard/C63\\_4-2014.html](https://standards.ieee.org/standard/C63_4-2014.html)

[4] IECEE “EMC part 3-2 Limits” IECEE April, 4, 2012. Accessed July 2020

Available: [https://www.iecee.org/dyn/www/f?p=106:49:0::::FSP\\_STD\\_ID:28164](https://www.iecee.org/dyn/www/f?p=106:49:0::::FSP_STD_ID:28164)

[5] IECEE “EMC and functional safety, impact of IEC 61000-1-2” IEEE international symposium on EMC November 07, 2002. Accessed July 2020

Available: <https://ieeexplore.ieee.org/document/1032503>

[6] Pery, John “IPC Standard for determining current carrying capacity in printed board design” IPC international inc. September 24, 2009. Accessed July 2020

Available: <https://www.ipc.org/ContentPage.aspx?pageid=IPC-2152-Standard-for-Determining-Current-carrying-Capacity-in-Printed-Board-Design-Released>

[7] [NASA TECHNICAL STANDARD: SOLDERED ELECTRICAL CONNECTIONS](#)

- [8] Wire & Cable, Calmont. "Types of Conductors." *Calmont Wire & Cable*, Calmont Wire & Cable Inc, July 2020.  
Available: <https://www.calmont.com/resources/types-of-conductors/>
- [9] IPC-2221, Task Group "Generic Standard on Printed Board Design".  
Accessed July 2020 Available: <https://www.ipc.org/TOC/IPC-2221A.pdf>
- [10] Electrical 101, "Outlets and Plugs Outlets Receptacle". Accessed July 2020  
Available: <http://www.electrical101.com/receptacles.html>
- [11] Mohagheghi, Salman & Stoupis, J. & Wang, Z.. (2009). Communication Protocols and Networks for Power Systems – Current Status and Future Trends. 1 - 9. 10.1109/PSCE.2009.4840174. Accessed July 2020  
Available: [https://www.researchgate.net/publication/224408154\\_Communication\\_Protocols\\_and\\_Networks\\_for\\_Power\\_Systems\\_-\\_Current\\_Status\\_and\\_Future\\_Trends](https://www.researchgate.net/publication/224408154_Communication_Protocols_and_Networks_for_Power_Systems_-_Current_Status_and_Future_Trends)
- [12] Kezhen Shen, Impact of Surges on Equipment: Susceptibility of Electronics to Surge Damage, May.23.2019. Accessed July 2020  
Available: <https://www.nema.org/Standards/Pages/Impact-of-Surges-on-Equipment-Susceptibility-of-Electronics-to-Surge-Damage.aspx?key=67ri900e6rt5af#download>
- [13] A. Wilkins, J. Veitch and B. Lehman, "LED lighting flicker and potential health concerns: IEEE standard PAR1789 update," *2010 IEEE Energy Conversion Congress and Exposition*, Atlanta, GA, 2010, pp. 171-178, doi: 10.1109/ECCE.2010.5618050.
- [14] Erik Hinds, "Simple Overview of Osha Lighting Requirements for the Workspace." Feb 18, 2020. Accessed July 2020. Available: <https://www.makegreatlight.com/about-us/blog/simple-overview-osh-lighting-requirements-workplace>
- [15] LEDs Magazine, "UL initiates safety certification for LEDs and fixtures." Jan 18, 2007. Accessed July 2020. Available: <https://www.ledsmagazine.com/smart-lighting-iot/smart-cities/article/16700208/ul-initiates-safety-certification-for-leds-and-fixtures>
- [16] LEDs Magazine, "ANSI works to standardize LED datasheet for white LEDs (MAGAZINE)." Feb 5, 2013. Accessed July 2020. Available:

<https://www.ledsmagazine.com/smart-lighting-iot/white-point-tuning/article/16695090/ansi-works-to-standardize-led-datasheet-for-white-leds-magazine>

[17] Bluetooth “Specifications.” Accessed July 2020 Available:  
<https://bluetooth.com>

[18] IEEE “GET 802(R) Standards.” Accessed July 2020 Available:  
<https://ieeexplore.ieee.org/browse/standards/get-program/page/series?id=68>

[19] RFIDJournal. “A Summary of RFID Standards.” Accessed July 2020 Available:  
<https://www.rfidjournal.com/a-summary-of-rfid-standards#:~:text=ISO%20has%20developed%20RFID%20standards,RFID%20systems%20around%20the%20world.>

[20] Arduino “Arduino Uno WiFi.” Accessed July 2020 Available:  
<https://store.arduino.cc/usa/arduino-uno-wifi>

[21] Advanced Mobile Group “Why You Should Care About RFID Frequencies.” Accessed July 2020 Available:  
<https://www.advancedmobilegroup.com/blog/whats-the-deal-with-rfid-frequencies>

[22] Kivy “Kivy: Cross-platform Python Framework for NUI Development.” Accessed July 2020 Available: <https://kivy.org/#home>

[23] energyaustralia, Why Solar Panels Alone Can’t Power Your House, Accessed July 2020 Available: <https://www.energyaustralia.com.au/blog/better-energy/why-solar-panels-alone-cant-power-your-house>

[24] greenmatch, Solar Panel Facts, 02 July 2020. Accessed July 2020. Available: <https://www.greenmatch.co.uk/solar-energy/solar-panels/solar-panel-facts>

[25] greenmatch, Solar Thermal Panels, 07 May 2020. Accessed July 2020. Available: <https://www.greenmatch.co.uk/solar-energy/solar-panels/solar-panel-facts>

[26] Battery University, Comparing the Battery with Other Power Sources, 2019-03-28. Accessed July 2020.

Available:[https://batteryuniversity.com/learn/article/comparing\\_the\\_battery\\_with\\_other\\_power\\_sources](https://batteryuniversity.com/learn/article/comparing_the_battery_with_other_power_sources)

[27] EnergySage, How to choose the best battery for a solar energy system, 7/15/2020. Accessed July 2020.

Available:<https://www.energysage.com/solar/solar-energy-storage/what-are-the-best-batteries-for-solar-panels/>

[28] Battery University, What's the best battery, 2017-03-21. Accessed July 2020.

Available:[https://batteryuniversity.com/learn/archive/whats\\_the\\_best\\_battery](https://batteryuniversity.com/learn/archive/whats_the_best_battery)

[29] Battery University, Will the Reusable Alkaline Battery have a Future? Accessed July 2020.

Available:[https://batteryuniversity.com/learn/archive/will\\_the\\_reusable\\_alkaline\\_battery\\_have\\_a\\_future](https://batteryuniversity.com/learn/archive/will_the_reusable_alkaline_battery_have_a_future)

[30] Labman.phys, Thermal properties of matter, Accessed July 2020.

Available:<http://labman.phys.utk.edu/phys221core/modules/m9/materials.html>

[31] Instrumentation Tools “RTD wheatstone bridge circuits” PLC Courses.

Accessed July 2020 Available:

<https://instrumentationtools.com/rtd-wheatstone-bridge-circuits/>

[32] Omega “What is a thermistor and how does it work” Omega Engineering Inc., Norwalk CT, August 28, 2018. Accessed July 2020 Available:

<https://www.omega.com/en-us/resources/thermistor>

[33] Omega “Thermocouples” Omega Engineering Inc., Norwalk CT, August 22, 2018. Accessed July 2020 Available:

<https://www.omega.com/en-us/resources/thermocouples>

[34] Electronics Hub “Humidity Sensor-Types and working Principle” June 7, 2017. Accessed July 7, 2017 Available:

[www.electronicshub.org/humidity-sensor-types-working-principle/](http://www.electronicshub.org/humidity-sensor-types-working-principle/)

[35] Warmzone “Heated Driveways nine key topics about radiant driveway heating systems”. Accessed July 2020

Available:<https://www.warmzone.com/snow-melting/heated-driveway/heated-driveways.php#:~:text=There%20are%20two%20types%20of,hydronic%20technology%20to%20warm%20rooms.>)

[36] Unilock

<https://contractor.unilock.com/blog/heated-driveways-what-you-need-to-know-before-offering-this-solution-to-homeowners/#:~:text=Hydronic%20driveway%20heating%20systems%20are,the%20cost%20to%20operate%20it.>

[37] Macisaac, Dan & Kanner, Gary & Anderson, Graydon. (1999). "Basic physics of the incandescent lamp (Light Bulb)." *The Physics Teacher*. 37. 520-525.

[38] Nassar, Antonio & Mednik, Max. (2003). "Introductory physics of harmonic distortion in fluorescent lamps." *American Journal of Physics*. 71. 577-579.

[39] Pimputkar, S., Speck, J., DenBaars, S. et al. Prospects for LED lighting. *Nature Photon* 3, 180–182 (2009). <https://doi.org/10.1038/nphoton.2009.32>

[40] Demain l'énergie – Séminaire Daniel-Dautreppe. LEDs for lighting: Basic physics and prospects for energy savings. *Comptes Rendus Physique*, Vol. 18, Issues 7-8, Sep-Oct 2017. Pages 453-461.

[41] 1000 Bulbs.com. Understanding LED Drivers. Accessed June 2020. Available: <https://www.1000bulbs.com/pdf/understanding-led-drivers.pdf>

[42] Miller, Naomi J. & Poplawski, Michael E. Dimming LEDs with Phase-Cut Dimmers: The Specifier's Process for Maximizing Success, report, October 1, 2013; Richland, Washington.  
(<https://digital.library.unt.edu/ark:/67531/metadc864283/>: accessed July 26, 2020), University of North Texas Libraries, UNT Digital Library, <https://digital.library.unt.edu>; crediting UNT Libraries Government Documents Department.

[43] eldoLED. Lighting Control Systems, White Paper. Accessed June 2020. Available:  
<https://www.eldoled.com/support/learning-center/lighting-control-systems/>

[44] Nitterhouse Masonry Products. Best Paver Base Material. Accessed June 2020. Available:  
<https://www.nitterhousemasonry.com/pavers/best-paver-base-material/>

[45] Hans Fredrick, "Fiberglass vs. Plexiglass." Accessed June 2020. Available:  
<https://www.hunker.com/12575689/fiberglass-vs-plexiglass>

- [46] Giovanni Blandino, "What is Plexiglass? The Alternate to Glass that's Perfect for Printing." Mar 3, 2018. Accessed Jun 2020. Available: <https://www.pixartprinting.co.uk/blog/what-is-plexiglas/>
- [47] Todd Johnson, "What is fiberglass and How is it Manufactured?" Updated Jan 3, 2020. Accessed June 2020. Available: <https://www.thoughtco.com/what-is-fiberglass-or-glass-fiber-820469>
- [48] Builderology, "Types of Wood & Their Uses." Accessed July 2020. Available: <https://builderology.com/types-of-wood/>
- [49] Blain Mikkonen, "How to Choose the Best Wood Finish For Your Project." May 31, 2017. Accessed July 2020. Available: <https://www.graindesigns.com/best-wood-finish/>
- [50] Wood Epoxy World, "Epoxy or Polyurethane for Wood? 9 Pros and Cons of Each." Accessed July 2020. Available: <https://woodepoxyworld.com/epoxy-or-polyurethane-for-wood-9-pros-and-cons-of-each/>
- [51] Theoec "Netmetering: Consumer, Environmental, and grid benefits". Accessed July 2020 Available: [www.theoec.org/net-metering/](http://www.theoec.org/net-metering/)
- [52] Gold Phoenix PCB "PCB manufacturing quote estimate". Accessed July 2020 Available: [www.goldphoenixpcb.com](http://www.goldphoenixpcb.com)
- [53] 4 PCB "PCB manufacturing quote estimate". Accessed July 2020 Available: <https://www.4pcb.com/>
- [54] Express PCB "PCB manufacturing quote estimate". Accessed July 2020 Available: <https://www.expresspcb.com/>
- [55] Solarroadways "SR3: Phase 3". Accessed July 2020 Available: <https://solarroadways.com/our-journey/>
- [56] Adafruit "10k precision epoxy thermistor". Accessed July 2020 Available: <https://www.adafruit.com/product/372>
- [57] Warmly Yours "Snow Melt Cables". Accessed July 2020 Available: <https://www.warmlyyours.com/en-US/products/line/snow-melting-cable>



[58] Electronics Hub, “WS2812B Addressable RGB LEDs | Control Using Arduino.” Accessed July 2020. Available:  
<https://www.electronicshub.org/ws2812b-addressable-leds/>

[59] Adafruit “Using a Thermistor”. Accessed July 2020 Available:  
[www.learn.adafruit.com/thermistor/using-a-thermistor](http://www.learn.adafruit.com/thermistor/using-a-thermistor)

[60] Arduino “Using a DHT11 Humidity sensor”. Accessed July 2020 Available:  
[www.create.ardunio.cc/projecthub/ARca\\_Ege/using-dht11-b0f365](http://www.create.ardunio.cc/projecthub/ARca_Ege/using-dht11-b0f365)

## 8.2. Datasheets

Humidity Sensor-

[https://cdn-shop.adafruit.com/datasheets/103\\_3950\\_lookuptable.pdf](https://cdn-shop.adafruit.com/datasheets/103_3950_lookuptable.pdf)

Thermistor -

[https://cdn-shop.adafruit.com/product-files/372/103\\_3950\\_lookuptable.txt](https://cdn-shop.adafruit.com/product-files/372/103_3950_lookuptable.txt)

Heating cable-

<https://www.warmlyyours.com/en-US/products/line/snow-melting-cable>

AC to DC Converter - IRM-15-5

<https://www.meanwell.com/Upload/PDF/IRM-15/IRM-15-SPEC.PDF>

DC to DC Converter - TPS82084

<https://www.ti.com/lit/ds/symlink/tps82084.pdf?HQS=TI-null-null-digikeymode-df-pf-null-ww&ts=1595851768182>

LED Strip - WS2812B - <http://www.world-semi.com/DownLoadFile/108>

Water Sealant - DAP Dynaflex -

<https://images.homedepot-static.com/catalog/pdfImages/57/5723f6e3-af2d-43fc-87cb-f8e41c282cc8.pdf>

## 8.3. Permissions

Permission to use picture from website ✕ 🖨 📧

**Bobby Federici** <bfed999@gmail.com>  
to elktros ▾ Tue, Jul 21, 8:14 AM (3 days ago) ☆ ↶ ⋮

To Whom it May Concern,

Good Morning. I am a senior Electrical Engineering undergraduate student at the University of Central Florida. I am working on my senior design project and we are planning on using the WS2812B LED strip for it. I was hoping to receive permission to use the Arduino connection picture below from the article on your website, "WS2812B Addressable RGB LEDs | Control using Arduino" in my research paper.

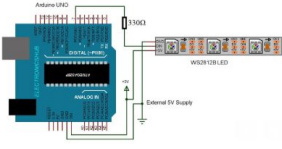

I am looking forward to hearing from you!

Thank you,

Bobby Federici  
[bfed999@gmail.com](mailto:bfed999@gmail.com)

---

**ElectronicsHub.org**  
to me ▾ Thu, Jul 23, 3:31 PM (17 hours ago) ☆ ↶ ⋮

You can use, don't forget to give Credit link back to our website  
xxxx

Admin  
Leona Lee  
[electronicshub.org](http://electronicshub.org)  
[Facebook](#) | [YouTube](#) | [Pinterest](#) | [Instagram](#)

WS2812B LED ✕ 🖨 📧

**Bobby Federici** <bfed999@gmail.com>  
to yin ▾

To whom it may concern,

I am an electrical engineering student at the University of Central Florida. I will be using the WS2812B LED strip for my senior project, and I was wondering if I could be granted permission to use the image below in my paper. Please let me know.

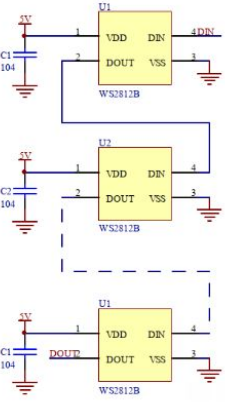

Thank you!

Bobby Federici  
[bfed999@gmail.com](mailto:bfed999@gmail.com)

**yin** <yin@world-semi.com>  
to me ▾

Yes, welcome, Can I help you?

YIN  
TEL: 86-769-8161-9276  
MOB: 86-186-0307-8980  
WECHAT: worldsemi  
<http://www.world-semi.com>  
**WORLSEMI LIMITED**



**Adafuit Industries** <support@adafruit.com>

to me ▾

hi dave, thanks for note, all good and approved.

cheers,

adafruit support, phil

On Mon, Jul 20, 2020 at 8:04 PM Dave Berlino <[contact\\_us\\_forms@adafruit.com](mailto:contact_us_forms@adafruit.com)> wrote

contactname : Dave Berlino

email address : [z33dave@gmail.com](mailto:z33dave@gmail.com)

Message : Hello, I would like to request permission to use pictures from this link <https://learn.adafruit.com/thermistor/using-a-thermistor> published on your website for my senior design project

Thanks,

Dave Berlino

Client IP: 107.145.114.96