

AUDIOVISIBLE

An Audiovisual Spectrum Analyzer for an Underserved Audience

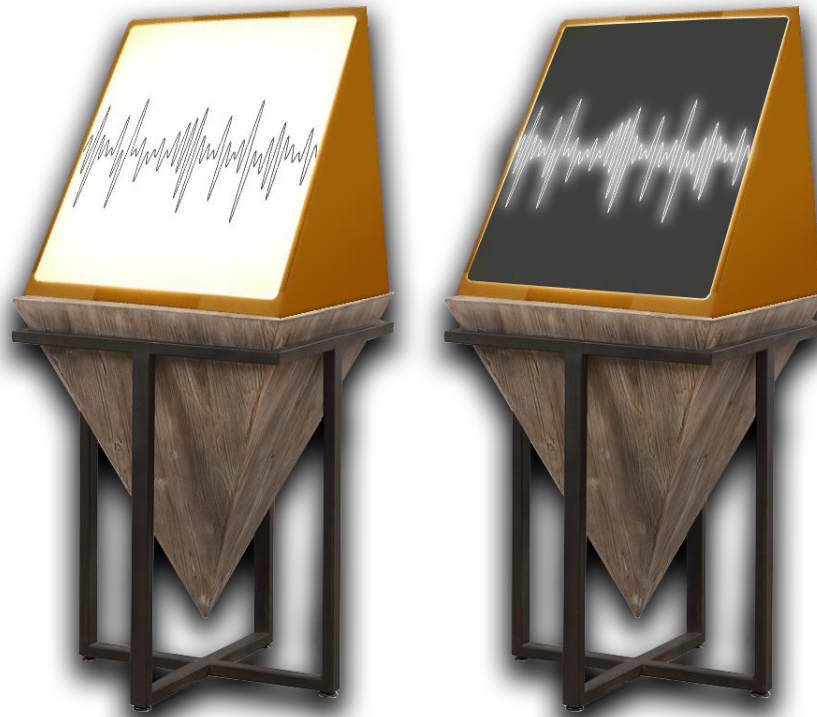

UCF Senior Design 1

Summer 2020

Group #3

Danielle Garsten, CPE
Gustavo Monaco, CPE

Jaaquan Thorpe, CPE
Marcos Berrios, PSE

Contents

1.0. Executive Summary.....	1
2.0. Project Description	3
2.1. Project Motivation and Goals	3
2.2. Objective and Features	4
2.2.1. Objective	4
2.2.2. Core Features	4
2.2.3. Advanced Features	5
2.2.4. Stretch Goals	6
2.3. Requirements	9
2.3.1. Marketing	10
2.3.2. Engineering Requirements.....	14
2.4. House of Quality.....	15
2.5. Block Diagram	16
3.0. Research	18
3.1. Existing Similar Projects and Products.....	18
3.1.1. Commercial Products.....	18
3.1.2. Works of Art	20
3.1.3. Engineering Prototypes.....	23
3.1.4. Summary of Similar Projects and Products.....	24
3.2. Relevant Theories	25
3.2.1. Color Theory – Additive vs. Subtractive	25
3.2.2. Music Theory	28
3.2.3. Harmonics and the Fourier Transform	29
3.2.4. Optical Lensing	29
3.2.5. Real-Time Systems.....	34
3.2.6. DSP Fundamentals	35
3.3. Strategic Components and Part Selections	36
3.3.1. Optical Module	36
3.3.2. Optical Engine Selection	42
3.3.3. Microcontroller	47
3.3.4. Audio Input - Bluetooth.....	51
3.3.5. Audio Output – Speakers	54
3.3.6. Audio Processing – Host Processor.....	55

3.4 Hardware Design Details.....	62
3.4.1. Optics Assembly	63
3.4.2. Audio Assembly	63
3.4.3. Power Assembly	64
3.5. Software Design Details	66
3.5.1. Software Architecture.....	66
3.5.2. Programming Languages.....	68
3.5.3. Artificial Intelligence and Neural Networking	70
3.5.4. Audio Processing	72
3.5.5. Audio Visualization.....	75
3.6. Software Tools	79
3.6.1. Visual Studio Code.....	79
3.6.2. Git	80
3.6.3. Microsoft Azure DevOps	80
3.6.4. Microsoft Teams.....	80
3.6.5. Eagle.....	80
3.7. System Housing	81
3.7.1. Housing Materials	81
3.7.2. Projection Screen.....	82
3.7.3. Construction Process	83
3.7.4. Conclusion	84
4.0. Standards and Realistic Design Constraints.....	85
4.1. Standards.....	85
4.1.1. Hardware	85
4.1.2. Software.....	89
4.2. Realistic Design Constraints	90
4.2.1. The Pandemic.....	91
4.2.2. Economic and Time constraints	91
4.2.3. Environmental, Social, and Political constraints	91
4.2.4. Ethical, Health, and Safety constraints.....	92
4.2.5. Manufacturability and Sustainability constraints.....	92
5.0. Project Hardware and Software Design.....	93
5.1. Optical Controller Assembly	94
5.1.1. Display Controller.....	95

5.1.2. Power Management and Diode Driver IC.....	97
5.1.3. DMD Interface.....	98
5.1.4. Board Connectors.....	99
5.2. Optical Engine Assembly.....	100
5.2.1. Illumination Diodes.....	102
5.2.2. Collimating lenses.....	103
5.2.3. Dichroic mirrors and relay lens.....	103
5.3. Audio Output Assembly.....	103
5.4. Power Input Assembly.....	105
5.5. Microcontroller Assembly.....	105
5.6. Software Design.....	106
5.6.1. The Listener.....	106
5.6.2. The Worker.....	107
5.6.3. The Player.....	107
6.0. Project Prototype Construction and Coding.....	109
6.1. PCB Vendor and Assembly.....	109
6.1.1. PCB Unlimited.....	109
6.1.2. Easy PCB USA.....	109
6.1.3. Advanced Circuits.....	109
6.1.4. Sunstone Circuits.....	110
6.1.5 OSHPark.....	110
6.1.6 Conclusion.....	111
6.2. Single Board Computer.....	111
6.2.1. Configuration.....	112
6.3. Website.....	112
6.4. Final Coding Plan.....	112
6.4.1. Development Life Cycle.....	113
6.4.2. Continuous Integration.....	114
6.4.3. Continuous Deployment.....	115
6.4.4. Software Versions.....	117
6.4.5. Stretch Goals.....	119
7.0. Project Prototype Testing Plan.....	120
7.1. Hardware Test Environment and Breadboard.....	120
7.2. Hardware-Specific Testing.....	120

7.2.1. Speaker.....	120
7.2.2. DLP2000 Evaluation Module.....	121
7.2.3. Laser Diodes.....	121
7.3. Software Test Environment.....	122
8.0. Administrative Content.....	123
8.1. Milestone Discussion.....	123
8.2. Budget and Finance Discussion.....	123
8.3. Purchasing Status Summary.....	124
9.0. Conclusion.....	125
10.0. Bibliography.....	126

Table of Figures

Figure 1: Simplified Sonochromatic Scale, by Neil Harbisson.....	5
Figure 2: In the image above is the Traktor DJ mobile app, but Creator Suite would be somewhat similar with waveform manipulation [11].....	7
Figure 3 - DeepDream Visualization Example.....	8
Figure 4 - A DeepDream Visualization using two pictures.....	9
Figure 5 - PWM signals of varying duty cycles.....	11
Figure 6: House of Quality diagram.....	16
Figure 7– AUDIOVISIBLE System Block Diagram.....	17
Figure 8 – Lightform AR Projector images. On the left, the internal components of the Lightform device; on the top right is the optical assembly; on bottom right, is a snapshot of the implementation of this device on a wall in a street.....	18
Figure 9 - Dancing Water Speakers by Leading Edge.....	19
Figure 10 - JBL Pulse 4.....	20
Figure 11 - Projection One: on top left is an image with the basic idea of the projection on strips of screen; on top right is an actual picture of the art installation; on bottom left is the close up of the material used for the screen, tulle, the same material used in wedding gowns; on the bottom right, is a snapshot of the art installation when projecting waves.....	21
Figure 12 - Bluetooth Speaker Sculpture: on the left, the assembly breakdown of the parts, and on the right, the actual artifact.....	22
Figure 13 - Snapshot of Melting Memories by Refik Anadol, at the Pilevneli Art Gallery in Istanbul.....	23
Figure 14 - Laser Musical Instrument, still capture from video demonstrating functionality in a dark environment.....	24
Figure 15 - Dancing Water Display: on the left, a still capture of a video demonstrating the water jets and LED illumination; on the right, the final product as presented to judges.....	24
Figure 16 - Various Color Gamuts Plotted on CIE 1931 Chromaticity Diagram [29].....	26

Figure 17 - Harbisson's Pure Sonochromatic Music Scale is a non-logarithmic scale based on the transposition of light frequencies to sound frequencies, which is used to convert visible color into an audible tone.....	28
Figure - 18 Example of refractive optics at work. Image on the left shows light incident on an interface between two different refractive indices. As it crosses the border into the higher refractive index (labeled n_2), its direction of propagation bends toward the normal of the boundary between the two mediums. Image on the right shows this principle at work on a (still living) young man in a swimming pool with a transparent wall. [45].....	30
Figure 19 - the greater the angle at which light impinges on a refractive surface, the more it bends. This allows for the design of lenses that can focus light focus light to one point [46]	31
Figure 20 - Diffraction depicted. On the left: Light diffracting through a single slit, behaving as a point source of light. On the right: The diffraction pattern seen when light is incident on many different slits (i.e. a grating)	32
Figure 21 – Depiction of a refractive lens and its analogous diffractive lens Left: Conventional refractive lens of fixed thickness and curvature. Right: Diffractive grating designed for the focusing of light. Note the significant reduction in thickness of the lens when comparing it to its predecessor [49].....	33
Figure 22 - Liquid crystal molecules aligned in the z-direction	33
Figure 23 - Actual diffractive waveplate lens made from liquid crystal polymer, produced locally by BEAM Engineering Co. in Orlando, FL [51].....	34
Figure 24 - Real Time System Diagram	35
Figure 25: Incandescent white light sources. Metal Halide Lamp (left) and UHP Lamp (right)	37
Figure 26 pre-assembled LED Array	38
Figure 27: Generic Schematic for a DLP projector taken from ViewSonic. Note the system for combining Red, Green, and Blue light sources into one homogenized beam [58]	39
Figure 28: Two DMD pixels, each mirror is shown to be transparent. Note how they are pointing int two directions: positive and negative 10 degrees, indicating that these are the "on" and "off" states for this DMD [61].....	41
Figure 29 Texas instruments DLP2000 Evaluation Module	43
Figure 30 Texas instruments DLP2010 Evaluation Module	44
Figure 31 Texas instruments DLP3310 Evaluation Module	45
Figure 32 Texas instruments DLP4710 Evaluation Module	46
Figure 33 - Arduino Nano	47
Figure 34 - MSP430G2553.....	48
Figure 35 - STM32F3 DISCOVERY	50
Figure 36 - WHDTS Stereo Bluetooth Power Amplifier Board	52
Figure 37 - Wireless BT HC-05 photo and pinout.....	52
Figure 38 - Raspberry Pi 4 Model B	56
Figure 39 - GPIO Connector Pinout for Raspberry Pi 4.....	58
Figure 40 - NVIDIA Jetson Nano	59
Figure 41 - NVIDIA Jetson Nano Data Sheet.	60
Figure 42 - BeagleBone Black (BBB)	60

Figure 43 - Key features of the BeagleBone Black.....	61
Figure 44 - Preliminary rough sketch/rendering of the expected optical components needed to achieve a successful prototype.....	63
Figure 45 - Audio Output Block Diagram.....	63
Figure 46: Diagram as to how the signal is interpreted through the speaker.....	64
Figure 47 - Tensorflow usage example.....	71
Figure 48 - Keras usage example.....	72
Figure 49 - The Canonical WAVE File Format.....	73
Figure 50 - FFT – Different Input Frequency.....	74
Figure 51: Image from a digital graphic equalizer showing the harmonic breakdown of an audio signal (image taken from presonus).....	76
Figure 52 - The Pyramid of Sound.....	77
Figure 53 - Concentric circles as an example of what could be possible.....	78
Figure 54 - Random Psychedelic Art by Jeremy Kun.....	79
Figure 55: Visual Studio Code Editor [99].....	79
Figure 56 - NEMA 1-15R (Socket A).....	86
Figure 57 - NEMA 5-15p (Socket B).....	87
Figure 58 - DLP230NP DMD.....	87
Figure 59 - A chart correlating each laser class and its potential severity of injury [112].....	88
Figure 60 - Infographic breaking down the four different laser classes, their subclasses and how to treat them as safety hazards according to the FDA. [112].....	89
Figure 61 - Initial Product Schematic.....	93
Figure 62 - Typical DLP™ Pico System Block Diagram.....	94
Figure 63: DLPC2607 Block Diagram showing internal processing and input and output functionality.....	95
Figure 64 - DLPC2607 Data Interface.....	96
Figure 65 - DLPC2607 Serial Flash Interface.....	97
Figure 66 - DMD Flex Cable Connector.....	99
Figure 67 - Optical Components in an Example Pico Projection Optical Module taken from Texas Instruments [121]......	101
Figure 68 - Finalized Optical Setup Schematic. Pictured: Planned Illumination Setup (boxed in red) and simplified projection setup (boxed in blue).....	102
Figure 69 - Example of a LC diffractive lens. Both images are of the same laser and the same lens, but with different circular polarizations running through. It is easy, but critical to get the proper polarization passing through the system [51]......	103
Figure 70: Harmonic Distortion is when the waveforms are clipped, having the sound be off tone.....	104
Figure 71: Intermodulation distortion is when sounds combine to produce an unexpected output of clashing.....	105
Figure 72 - Power Input Block Diagram.....	105
Figure 73 - Microcontroller Block Diagram.....	106
Figure 74 - Software Functional Diagram.....	106
Figure 75 - Software Development Cycle.....	113

Figure 76 - Screenshot of the Online Source Repository	114
Figure 77 - Deployment Group Details.	115
Figure 78 - Screenshot of the CD pipeline instance of the second automated deployment to a Raspberry Pi 4	116
Figure 79 - Output example using PyAudio and Matplotlib libraries with input from microphone.....	118
Figure 80 - Unboxed DLP2000 Optical engine and PCB. The top left image shows the module still having the silver heat sink on it; the top right image show the heat sink removed. Circled in red are the screws that need to be removed in order to expose the optics inside the engine. The botom left and right images show the device plugged in and the EVM performing exactly as expected and promised by Texas Instruments.	121

Table of Tables

Table 1 – Summary of Requirements	10
Table 2 - Illumination Comparison.	39
Table 3 - Optical Engine Comparison.....	47
Table 4 - Microcontroller Comparison.....	51
Table 5 - Bluetooth Comparison.....	54
Table 6 - Speaker Comparison.....	55
Table 7 - Single Board Computer Comparison.....	62
Table 8 - Software Architecture Comparison.....	68
Table 9 – Audio Processing Programming Language Comparison.	70
Table 10 - Microcontroller Programming Language Comparison	70
Table 11 - System Housing Summary	84
Table 12 - Operating specifications of the laser diodes used for illumination of this project.....	102
Table 13 - PCB Vendor Comparison.	111
Table 14 – Excerpt from Frequency RGB assignment based on Harbisson's Sonochromatic Scale.....	118

1.0. Executive Summary

Aside from actual paintings and videos, there is no existing form of art intended to cater specifically to people who are deaf and hard-of-hearing. The blind can hear music and can feel the textures of risen-surface artworks, the deaf can see paintings but cannot generally feel sound. Although they can feel lower frequency vibrations if they are amplified enough, deaf people are virtually incapable of perceiving something that many hearing people consider to be a necessity in their lives: music.

Many devices and products exist to create a kind of visualization to accompany music for those who can already hear it, but very few if any exist to be a complete repurposing of music to be enjoyed through a completely separate medium. Knowing this, we set out to attempt to make something that could actually do this. Our project's intended purpose is to transform a form of art that one is supposed to be able to hear, into a pleasing display that is meant to be viewed and experienced by the eyes instead of the ears.

AUDIOVISIBLE is intended to be a device that will transform music into light. It receives live input audio via Bluetooth connection, and through the use of Fourier transforms, breaks the signal down into its composite fundamental frequencies. It then uses this information to assign colors to the pitches (frequencies) detected in the music, as well as generate moving image that will respond to the signal in real time. The image is produced by a DLP projection setup consisting of a digital micromirror device illuminated by an RGB laser diode array. This setup will illuminate a thin translucent viewing screen from behind, making the device appear similar to a portable television.

The task of transforming pitch to color is a complicated one, as the audible spectrum of sound runs from 20Hz to 20kHz, while the visible spectrum of light runs from 4×10^{14} Hz to 8×10^{14} Hz—two completely different scales. We have made use of the sonochromatic music scale; a logarithmic scale developed by artist Neill Harbisson to assign certain colors to sound frequencies. Using this scale, we can assign any note in any octave of any music score to a specific color representation in the RGB array. Colors will be produced by laser diodes operating at wavelengths of 648nm for Red, 520nm for Green, and 450nm for blue. The use of pure monochromatic light sources such as lasers allows for a very broad spectrum of possibility when it comes to synthesizing and projecting colors out of the system. As beam mixing and illumination uniformity are of utmost importance to the successful operation of the projector, the lasers will be focused using specifically coated, monochromatic ultrathin lenses fabricated using liquid crystal-based diffraction waveplate lenses.

In this project, signal analysis and processing speed are of utmost importance. In order to accurately and efficiently perform this processing, the analog signal received by the Bluetooth module will be processed by a Wi-Fi-enabled Raspberry Pi. The Raspberry Pi will process the signal, perform the harmonic assessment

and color assignment and send that information to a microcontroller used to separately control color output and image production on the DMD/DLP chipset.

AUDIOVISIBLE offers superior visuals for any individual's artistic/musical needs, providing the most immersive, personalized experience with vibrant colors and intricate shapes. Our team's goal is to ensure that users can feel fully immersed in a visual experience with full music-to-visual correlation.

Our audience is comprised of not only people who are hearing-impaired, but also those who listen to music and are interested in seeking a more entranced visualization, including artists, DJs, and even those who simply hold gatherings and parties in their homes. AUDIOVISIBLE offers a variety of audiovisual services, all in a home environment, including:

- Vibrant laser projections
- Crisp audio
- Quick buffer timing
- One-of-a-kind visuals

AUDIOVISIBLE emphasizes the quality of visual clarity and high-quality audio. Those who come home from a long workday can just turn the device on and just relax to their experience. Users can stream slow, calming music and expect a display to fit to that experience, or they can stream fast-paced, energetic music and see a lively, dancing display further enhancing the mood. While there are currently other business offering similar services, AUDIOVISIBLE is a one-of-a-kind product, opening users to a new world of possibility in their music-listening experience.

2.0. Project Description

In the simplest terms, this project's intended purpose is to transform music into light. It will receive an audio input chosen by the user and showcase a visual signal that is correlated to and therefore representative of the sound data. It can work with any smartphone via Bluetooth, and therefore can work with any music streaming service. It will convert and display any musical data into visual display in real-time.

In this section we will discuss the motivations for creating this project, as well as a number of the studies, innovations and technologies that inspired the idea in the first place. We'll touch on the earliest appearances of art in human history, as well as the long history of mankind attempting to study, quantify, and elevate the fields of art and art appreciation

2.1. Project Motivation and Goals

Art is an inherent part of the human condition. Prehistoric cave paintings, and portable art, including musical instruments, sculptures, and paintings date back to our prehistory, as far back as one hundred thousand years ago. The fact that the oldest musical instrument, a flute [1], predates the invention of the wheel is a profound realization about what it means to be human. Today, art has become so widely recognized and valued as a good (and even a necessity), that some of the most recognizable and influential people in our society are artists.

Despite this, there are still certain forms of art that certain demographics are unable to experience and ultimately enjoy. For example, the deaf are obviously unable to perceive and enjoy music the same way the hearing can. The goal of this project is to make a device that can take a musical input and transform it into a visible, loyal, visual representation of the music. This device will transform the pitch part of the music directly into color, as well as using the volume of the sound to determine the brightness of the display. Finally, we intend to include a third dimension, transforming the timbre or harmonic "shape" into a visible pattern.

The idea of attempting to connect visualization to music can be dated to the early 1900s, when neuropsychiatrists Pierre Janet, Jean-Marie Carchot, and others tested LSM (Light Sound Meditation) on patients, which would induce a hypnotic state of audiovisuals that was tested by EEG [2]. Although it was only used as a therapeutic method for those with mental illnesses, it shows that the brain has the capability of translating and transducing various sounds to various lights and/or colors.

Moving into the 1960s was the combination of psychedelic drugs and music to have audio-visual hallucinations. Psychedelic music was a result of reform and going against the conformities of society. Psychedelics created a 'trance' with various notes of music making alterations in the visuals individuals experienced. As a result of psychedelics having drastic effects on the user's body, a new initiative was to try mediation with art and music [3] [4]

Thomas Edison's phonograph in 1857 and Nikola Tesla's wireless radio invention in 1893 were both revolutionary to the foundations of audiovisuals. An invention to assist with converting this analog wave to something humans can see is the Analog-to-Digital Converter (ADC). This device will allow for a simple, lightweight and cost-effective manner to convert analog sound data into digital information for analysis and conversion [5].

Digital light processing (DLP) is a relatively recent concept by Texas Instruments in 1993 where micromirrors are manipulated by digital authority, which allowed for mini projectors and personal computers. It uses Digital Micromirror Devices (DMDs) for projecting images onto objects. It is used for both front and rear projection devices and is in the form of a microchip. In the DMD chip contains millions of microscopic mirrors that can be rotated. To have colors show on a screen, there is a color wheel of RGB placed in between light and the DMD. While deciding which design would be the most efficient for our project, we chose DLPs over Liquid Crystal Displays (LCDs) and Liquid Crystal on Silicon (LCoS) because it is simpler to design, much cheaper, and much more reliable [6] [7] [8] [9].

There are plenty of devices that create something resembling a true visualization of music, like popular speakers with colored LEDs (like the JBL Pulse) who illuminate specifically according to volume, or music visualizing software out there such as Spectrum Music Visualizer, who can identify the tempo of the music and make pre-determined images move according to that beat, creating the illusion of music visualization. Our device is unique in that it creates "true" music visualization by tailoring the experience specifically to the tune it registers.

2.2. Objective and Features

This project aims to fulfill a human need through a set of discrete attributes, in other words, the same abstract definition of any worthy engineering project.

2.2.1. Objective

The AUDIOVISIBLE device has been devised to fulfill a single yet daunting objective: to serve an underserved audience, and serve it well, by delivering the visual experience of an audio experience. In other words, this device will attempt to make music, visible, for the deaf and hard-of-hearing population.

However, there is always loss in translation. From one language to another, from one state of matter to another, from a signal to another, entropy is always there to impose a fee. Therefore, it is understandable that regardless of how well AUDIOVISIBLE can depict a particular note or instrument, it can never replace the real thing.

On the bright side, having the common audio output as other speakers, AUDIOVISIBLE can also serve a broader audience by providing the expected audio performance of regular wireless speakers, with a visual twist.

2.2.2. Core Features

In order to fulfill the objective, it is mandatory to define a set of main attributes or core features. These features are the basic building blocks of AUDIOVISIBLE.

2.2.2.1. Multi-color display

Music is full of nuance and beauty in sound, which in order to make visible, would require as many visually available phenomena as possible. Colors, and a multiplicity of them, are part of the path to see sound. Color can convey emotions, moods, states of mind, and so much more. Capitalizing in color, by building on existing scientific research and existing innovative solutions, AUDIOVISIBLE plans to build on the work from Neil Harbisson, who was born with a condition called achromatopsia, or total color blindness. Neil can now hear colors with the help of an “electronic eye”, a camera mounted on his head, which detects the color frequency in front of him, sends the frequency to a chip installed in the back of his head, which transforms it into an audible frequency, and transmits it through bone conduction. AUDIOVISIBLE will do the exact opposite.



Figure 1: Simplified Sonochromatic Scale, by Neil Harbisson.

2.2.2.2. Audio output

The audio from our device will be able to play crisp, clear sound as well as correlate to the visuals that are outputted. With an included speaker and audio amplification, a louder volume can be outputted across a room. Although this feature is not serving the deaf and hard of hearing audience directly, it is a simple and common feature found in many wireless speakers, necessary to allow this a device to be shared with others in a group, where these others might have good hearing, and therefore expect to hear the music.

2.2.3. Advanced Features

Given the basic and core features, which can be found in many other existing products and projects in the market and academia, this device will also offer some

more sophisticated characteristics to continue expanding on the objective of bringing the joy of music to the silent existence of the audience.

2.2.3.1. Visual representation of the sound

By no means a trivial goal, representing the beauty of music is a difficult technical challenge. AUDIOVISIBLE will probably require many iterations before getting this right, however, in this first iteration, the goal is to just see something. This something can take many forms, and only four common visual representations of sound have percolated up in the design of the device:

- **Waveform Simulation:** probably the simplest representation of sound is a wave. A sinusoidal wave is a good start but might lack the expressive nuance needed to convey music in all its variations.
- **Graphic Equalization:** the next logical step after the waveform, the equalization is a view that many observers will be familiar with. It might make other aspects of music visible, however other more complex expressive ideas might still be hard to display.

2.2.4. Stretch Goals

Time, cost and availability constraints might make these goals unlikely to be completed, however, the authors of this paper consider these worthy of exploring, and hopefully implementing. To summarize:

- **Concentric Shapes:** building on geometry and its infinity visual complexity, a set of concentric shapes might be exactly what is needed to offer the equivalent of sound fidelity to the visual world.
- **Random Psychedelic Art:** at the edge of our understanding of the inner workings of our human brains, visual plastic arts and psychedelics might be the next logical step forward. Using more complex software, and learning from cymatics [10], the goal is to create a visual experience rich in content
- **User Interaction:** making the user take part of the visualization process that would arise from the audio being played.
- **Mobile App:** in order to control the user settings, a mobile app and/or a web interface could allow for the user to request specific color pallets or visualizations.
- **Creator Suite:** a software suite that would allow artists create their own visualizations for specific pieces of music.
- **DeepDream:** an artificial intelligence implementation to create engaging and breath-taking visualizations that would be tailored to the specific music being played.
- **Audio Jack/Aux Port:** A input auxiliary port to plug in any speaker to the device.
- **Battery:** A portable battery so there is no need to plug into an outlet.

2.2.4.1. User Interaction

User interaction is when a user can interfere or manipulate the product of the device to fulfill their wants and satisfaction to their personalization. A user can

select what style, colors, or shapes they desire to see in the output and the neural network will recalibrate in terms of the input. For instance, a user may only input gold and black as their colors with some waveform and circle shapes and maybe the possibility of a sparkle setting. User manipulation would require more time on the machine learning aspect of the code as well as a whole UI form set up on the device.

2.2.4.2. Mobile Application

Mobile applications are the new trend of today where users can, with the tap of a couple buttons, have anything work at their fingers. This crosses over into Internet-of-Things (IoT), where hardware devices are connected to a smartphone, with the possibility of voice interaction as well or gathering images from the internet. A simplified mobile app for AUDIOVISIBLE will allow for a user to adjust brightness, volume of sound, and turn the device on and off. In later versions, more advanced features, such as the UI aforementioned, or more customization features, will allow for the technology in this product to be more distinguished and unique than devices from other companies.

2.2.4.3. Creator Suite

A UI tool called Creator Suite would allow for artists and individuals to formulate an image of their creation and control how sounds are based off that image. The artist can dictate how a certain color, brush, or shape is based off specific parts of the sound, such as the timbre or pitch. The user can also manipulate the physical waveform and have it to be the sound they executed. Creator Suite would be for more advanced applications and allow for more individuality and innovation within a user's experience.



Figure 2: In the image above is the Traktor DJ mobile app, but Creator Suite would be somewhat similar with waveform manipulation [11]

2.2.4.4. DeepDream

Throughout history, audiovisual experiences were seen as an experience, whether that be through television shows, concerts and festivals, or even psychedelic drugs themselves. Even dreaming can be considered a form of an audiovisual experience that is a naturally produced dystopia, and sometimes a euphoria. These mesmoric encounters are a way of escaping the reality that is imposed and provides a rise in serotonin. It also allows for recovery in terms of letting the brain not perform any strenuous activities.

Google has allowed for this dystopic dream state to come to fruition. In a project called "Deep Dream", a user inserts a photo and the code compiles it into a more picturesque and Van Gogh-style environment [12]. This metamorphic process allows for the visual aspects on the AUDIOVISIBLE device to be more like a psychedelic dream state. As the music part of this project has octaves, so does Deep Dream in how intense an image can be morphed. The process to achieve such an image would require the gradient ascent of a Deep Neural Network. DNNs alter the number of hidden layers. Essentially, some deep learning and computer vision concepts would have to be applied to learn the color and shape patterns and input some unique filters where needed.



Figure 3 - DeepDream Visualization Example

In Deep Dream, Google implements a Convolution Neural Network [13], which is mainly utilized for computer vision. As a sector of Deep Neural Networks, CNNs focus on the dense layers of the network. Taking inspiration from Deep Dream, bat-country implements a foreground image on a background image. The background image is the one being manipulated into a dream state and the foreground image is to formulate a pattern on the image [14].



Figure 4 - A DeepDream Visualization using two pictures

2.2.4.5. Audio Jack

Unfortunately, in this version of AUDIOVISIBLE, there will be audio jack to plug in an auxiliary cord and be able to have the freedom of a 4 to 8 ohm speaker of choice. A simple audio jack plug to the raspberry pi would be able to allow for speaker input. Having a user be able to use their own speaker would be a selling point but, it is way too extensive for the time limit. In a future version, there might be the possibility of a Bluetooth connection or mixed connection. Fortunately, this product has an included speaker so users can save their finances on a speaker.

2.2.4.6. Battery

For this version, there will not be a battery-operated design but, an outlet-friendly device. A user can plug this into any outlet. As it is not convenient for outdoors, there will be a plan in future versions to be able to have either solar power or a battery.

2.3. Requirements

During AUDIOVISIBLE initial conceptual stage, many different variations of the device were considered. After purposely organizing these variations into a set of stages or iterations, were each one would build on the previous, the following marketing requirements, and subsequent engineering requirements were agreed upon:

Marketing Requirements met	Engineering Requirements	Justifications
9	The product should have a weight less than 15 lbs.	15 lbs. are easily lifted with or without assistance
1, 4	It should have a display resolution of at least 640x360	The price of higher resolution components
1, 4	The display's contrast Ratio should meet 4.5:1	Easily discernible to the naked eye
1, 4	The display's framerate should not fall below 30Hz	30Hz is a common basic video framerate
7, 2	The product should not occupy a volume greater than 8 ft ³	This is an easy table-top size
1, 3	The delay between audio output and visual display should not exceed 500ms	If the delay between sight and sound is too great, it will be disorienting
9	It should cost less than \$500 to produce	This is a constraint
5	Bluetooth capability	Bluetooth connection is available on all smartphones
<u>Marketing Requirements</u> <ol style="list-style-type: none"> 1. The system should be visually engaging/immersive 2. The system can be shared with friends and family alike 3. The system should have excellent sound sensitivity 4. The system should have a good resolution display 5. The system should be easy to use. 6. The system should have low cost. 7. The system should have a low spatial footprint on an average living room. 8. The system should have an average low carbon footprint. 9. The system should be lightweight 		

Table 1 – Summary of Requirements

2.3.1. Marketing

The AUDIOVISIBLE device bridges the gap between audio and visuals, making audible music a visual experience. This will give deaf customers the opportunity to perceive and experience the form of art called music. Along with hard-of-hearing customers, all potential users will be able to enjoy the beauty of the music in a new form. The device will display a combination of different shapes, lights and/or colors, that is influenced by the volume, tune, pitch, and timbre.

In other words, the pitch will be broken down into a twelve-tone or “chromatic” scale. Each semitone above and below is adjacent to each other within an octave. Based on the chromatic scale, depending on the Frequency, in Hertz, of the sound from the mobile device to the AUDIOVISIBLE device, a select combination of colors will be displayed by the DMD. As the music is playing a series of notes in different octaves, the user will experience waves of different colors that will be programmed by the microcontroller to have a consistent visualization of color based on frequency.

The brightness of the display will be determined by the volume of the sound. By using, Pulse Width Modulation (PWM), the device would be able to detect the different frequencies from low to high. PWM is powerful technique for controlling analog circuits with a processor’s digital outputs. PWM is employed in a wide variety of applications, ranging from measurement and communications to power control and conversion. [15]

The same concept of controlling the analog signal of a car’s radio volume, the knob is connected to a variable resistor. When the knob is turned, the resistance changes either up or down, making the current that is flowing through either increase or decrease. This will adjust the current that is going through the speakers, causing the volume to go up or down. The only difference is that the microcontroller will digitally control the analog circuits, since it already has an on-chip PWM controller that makes the implementation easier. To encode the analog signal level, we will use the duty cycle of a modulated square wave through the use of high-resolution counters.

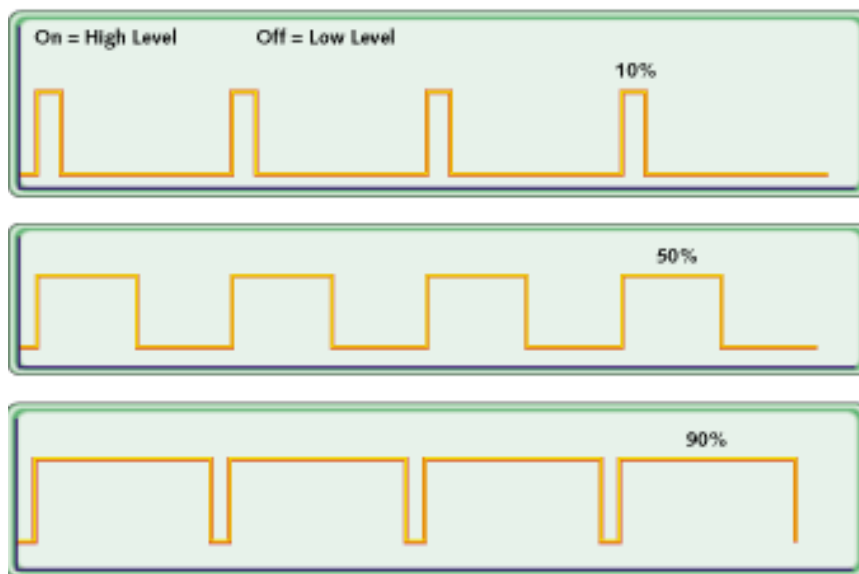

Figure 5 - PWM signals of varying duty cycles

In the figure above, we see a representation of three values of different duty cycles of a PWM signal. Using the cycle as an example of the brightness level of the display, the cycles will represent off, dim, and bright for the values of 10%, 50%, and 90%, respectively.

The visual pattern that would be seen on a screen will be determined by the timbre or harmonic “shape”. The relationship between timbre and shapes or visual patterns is fundamental frequency.

2.3.1.1. Visually Engaging

One of the major factors of this project is that it is visually engaging to the user. There is an exciting display of different shapes, colors, and brightness of colored lights. This would be a major marketing tool for the selling of this product. [16] When you consider that 65% of people are visual learners, 90% of information that comes to the brain is visual, and presentations with visual aides are 43% more persuasive, it makes sense that a visual based presentation of music will be attractive to the eye. [17]

Engaging your audience have never been an easy task but it is possible through several strategies such as having a variety of colors, shapes, and visual images to capture the eye. It takes more to hold the attention of the average viewer from just words alone. This device provides a variety of experiences in one sitting. When the device is being used, the consumer will not only hear the music that already love and relate to, the visual expression will ensure that users are captivated since the visuals are not random images. The visuals will be synchronized to the audio to make the experience more special and meaningful.

2.3.1.2. Group Friendly

Research has shown that music has a profound effect on your body and psyche. [18] In fact, there’s a growing field of healthcare known as music therapy, which uses music to heal. Music has the power to affect your state of mind, and has the possibility to assist with stress, anxiety, and depression. [19] As customers, get to enjoy a therapeutic experience, it becomes more attractive when you can do it in groups with the ones you love. When individuals get to spend time together in a group it opens the door for lifelong connections. The more people that will be exposed to this device by their peers and loved ones, it will allow the popularity rate to increase exponentially.

2.3.1.3. Harmonic accuracy

As AUDIOVISIBLE’s pivotal feature is converting musical pitch to color, it much be reasonably good at registering and identifying audio frequencies -- good enough such that it can register the difference between two music notes which are close in frequency. The sonochromatic music scale we intend to use breaks down no one color value for almost every integer value of sound frequency (in Hertz). This means that for the best results/trupest fidelity to the source, our device needs to be able to detect frequencies within a margin of error of one Hertz. This does scale, however: as the octave increases, it scales by a factor of two, so where we need to catch within one Hertz at the beginning of our frequency range, in the second octave above it we only need to have a resolution of two Hertz. In the third octave above that we only need a resolution of four Hertz, and so on.

2.3.1.4. Good resolution

Music is an intangible, almost ethereal experience. Only somewhat recently, in 1967, Swiss medical doctor and natural scientist, Hans Jenny, pioneered a new way of studying wave phenomena, something he called Cymatics [10]. This work demonstrated shapes and structures that were generated by soundwaves on matter, and it is the closest thing we have, to visualizing actual sounds. Now, in order to portray an orchestra, Cymatics is not ready for actual visualizations, however, the valuable lesson here is that resolution is not an important component. Music is fuzzy, one note entangled with another, and probably too complex to visualize in its entirety. In the same way, a fuzzy display, something that would allow our human brains to build upon, is all what is really needed.

2.3.1.5. Easy to use

The project being compatible with any device that has Bluetooth capabilities. This will allow for the users to virtually use any streaming service. The device is created to be stationary so there is no added pressure of constant moving and maneuvering.

Initially, the user will press the power button to turn on the device. Immediately, the AUDIOVISIBLE will enter pairing mode, in other words, the user will now be able to pair their Bluetooth supported device to the product. Once both devices are successfully connected, the user will have full functionality to play a live stream of music. The only additional button is the volume button. The volume button will adjust two things at once, the volume of the music that will be heard through the speakers and the brightness of the visuals that would be displayed on the screen.

The device has been engineered to be simple to use for all users. Today, majority of the population is familiar with using a power and volume button, including kids, adults, and seniors. A variety of devices such as a tv, radios, phones, and speakers encounter millions of people every day. The buttons on the device would be considered trivial and does not require a tutorial.

Fortunately, almost all recently designed phones, tablets, and pcs/laptops have Bluetooth capabilities all around the world. A 3-step assistance on how to connect to the device by using the Bluetooth feature will ensure that all users will not have any trouble being successful. Anyone can enjoy this device with or without previous technical knowledge.

2.3.1.6. Cost

To make the price of the device economically friendly is not an easy task since the budget for the implementation of the device is currently around \$500. To consider production cost, potential profit, and market worth, it would be difficult to maintain the price range to be less than \$500 per item. Utilizing proper supply chain technology will aid in keeping acquisition and production costs. The use of extensive logistics must be used to synchronize all of storage and transportation all AUDIOVISIBLE devices which will further control costs.

2.3.1.7. Size/Weight

The AUDIOVISIBLE will weigh approximately less than 15lbs and a 3ft screen to display the visualization. This device is marketed to remain stationary on a flat surface such as a table that is at least 2x2 ft for safety purposes. Space would not be a major concern for the consumer since a minimum amount of room is required to successfully operate the device. There will only be an additional power plug to power the device, so the only restriction when positioning the AUDIOVISIBLE is making sure a wall mount is in proximity, otherwise, an extension cord will be required.

2.3.1.8. Low Carbon Footprint

Ensuring that the device is manufactured using several sustainable materials is a priority. The facility where everything is manufactured has procedures in place to monitor the amount of carbon dioxide emissions that it is producing. That would play a role on the footprint created by the company. If the product needs to be discarded, the DLP chip set can be scrapped for metal after its use.

The device will only consume up to 10 watts while in use, which is not a lot of power. No batteries will need to be replaced to create an extra expense on the consumer. As long the device is kept indoors, in a room temperature environment, the device should not cause any potential bodily harm to the user. [20] Laser diodes uses optic fiber-based components, meaning there is a possible chemical combination of variety of different chemical compounds at different levels. Common compounds are ammonia, methane, carbon dioxide, hydrogen sulfide. These factors strongly depend on the nanometer of the lasers.

2.3.2. Engineering Requirements

From an engineering standpoint, abstracting the marketing requirements allows for an understanding of the necessary inner workings of the device, leading us to a list of important aspects, necessary to accomplish what AUDIOVISIBLE is supposed to be.

2.3.2.1. Display Resolution

nHD is a display resolution of 640 × 360 pixels, which is exactly one ninth of a Full HD (1080p) frame and one quarter of a HD (720p) frame. 1080p is also known as Full High-Definition, FHD, WUXGA, and BT.709. 1080p represents the pixel resolution 1920x1080, while “p” represents progressive, so there are 1080 vertical lines. For AUDIOVISIBLE, nHD is enough to have good resolution for music, and its cost is a fraction of higher resolution devices.

2.3.2.2. Contrast Ratio

Contrast Ratio is a property of a display system, defined as the ratio of the luminance of the brightest color to that of the darkest color that the system can produce. There is no real set standard on how to define or measure the contrast ratio. Contrast Ratio ranges from 1 to 21 or 1:1 to 21:1. Since, the visual presentation of text and images of text has a contrast ratio of at least 4.5:1, this project would only require the minimum 1.4:3 contrast for it to successfully display a visualization of sound with images and waveforms. [21]

2.3.2.3. Frame Rate

This device will have a frame rate of 30Hz, equivalent to a refresh rate of 15fps. 30Hz is a standard rate to display images, but the device will most likely display light so this frame rate will be just enough to give a clear view of the required display. If the features of the device are upgraded to be compatible to fulfill the stretch goals, then it will require us to increase the frame rate to 60Hz to have a reasonable refresh rate. This change will ensure that the consumer will not have difficulty seeing the display of images moving at high velocity such as 1000px/s.

2.3.2.4. Dimensions

AUDIOVISIBLE dimensions should not surpass 2'x2'x2', for a total volume of 8 cubic feet. It can be smaller, but it should not be larger than that.

2.3.2.5. AV Synchronization

The two different outputs, one for video and one for audio, should be as synchronized as possible, in order to maintain a coherent experience for the user. There will be a specific tolerance of up to 30ms, that way permitting a smooth 30Hz keeping the audio and video synchronized enough to avoid the user noticing.

2.4. House of Quality

House of Quality refers to a well-known process for product development that is inspired by customer desires for product or process development and anchored by the capabilities and resources of the organization seeking to meet those desires. It is a process of listening to customers, translating their desires into a written plan, prioritizing steps of execution based on what is most important to the customer, and putting a realistic plan on paper.

The AUDIOVISIBLE House of Quality is the following:

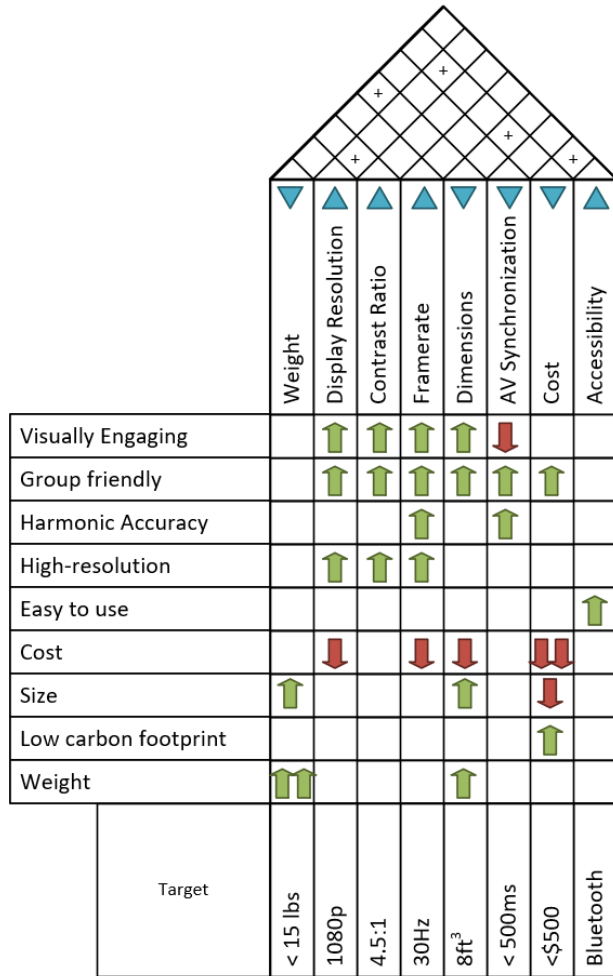
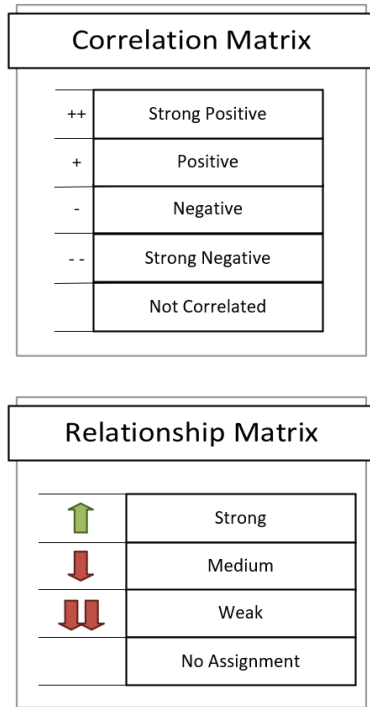

Figure 6: House of Quality diagram

2.5. Block Diagram

In a nutshell, the following block diagram contains all the important components of the system. There are five major components: the housing, the optics assembly, the single board computer, the power assembly, and the audio assembly.



Figure 7– AUDIOVISIBLE System Block Diagram.

In order to ensure that each part would be completed successfully, each member of the group is assigned a leading position for each aspect of the project:

- Danielle Garsten, Project Manager, Software Engineer
- Gustavo Monaco, Software and Production Engineering Lead
- Jaaquan Thorpe, Hardware Engineer Lead, Optical Design
- Marcos Berrios, Photonics Engineer Lead, Hardware Engineer

3.0. Research

In this section, the research related to the project definition can be found. Relevant theories, similar products, and strategic components and parts selection are the main topics to cover.

3.1. Existing Similar Projects and Products

Using the best resource available, the internet, we were able to find a several products that seem similar, however nothing exactly like it, which it is becoming increasingly worrisome as we get deeper into this project. In order to understand our competition better, we divided them into the three major categories: products, artworks and prototypes.

3.1.1. Commercial Products

The AUDIOVISIBLE device can be categorized under two different commercial areas: speakers and projectors. Both areas are flooded with options and variations that make this a very profitable and competitive market. The focus of this section would be to narrow down the expanse of the market to devices that show certain resemblance with AUDIOVISIBLE.

3.1.1.1. Lightform - AR projectors

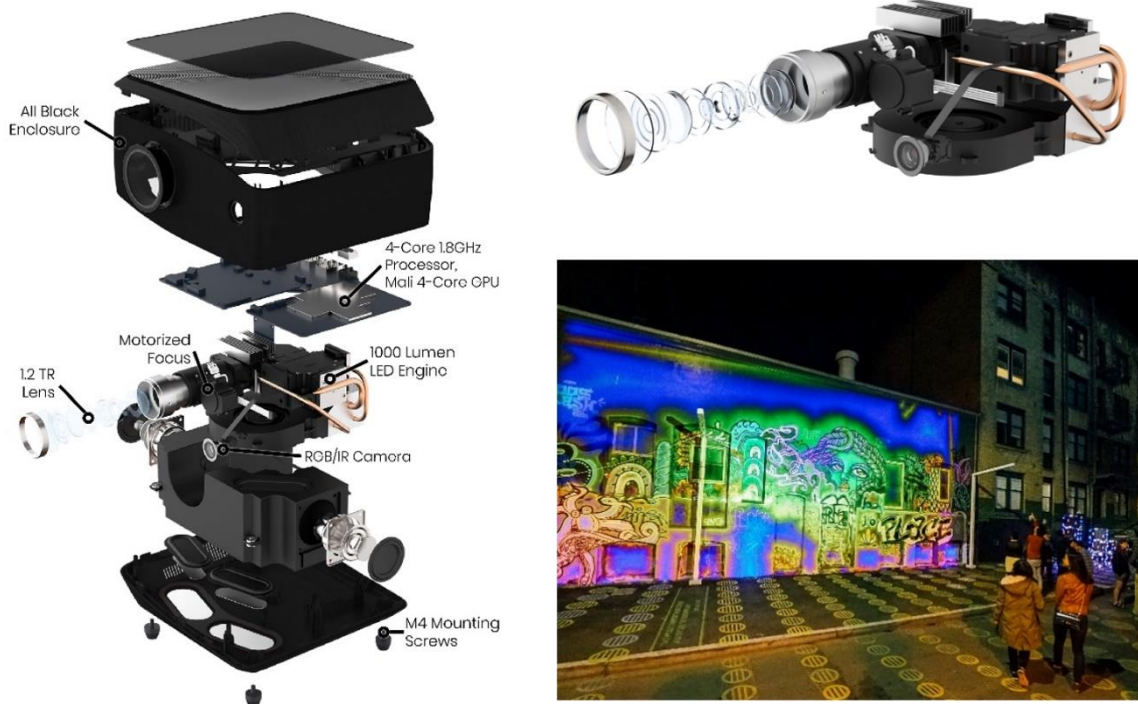

Figure 8 – Lightform AR Projector images. On the left, the internal components of the Lightform device; on the top right is the optical assembly; on bottom right, is a snapshot of the implementation of this device on a wall in a street.

From home offices to retail displays, LF2 adds ambiance & information to your space. The LED light engine has a 30,000-hour lamp life. That's >8 years at 10 hours a day, or >5 years at 16 hours a day. Create content with adaptive visuals powered by computer vision using the Lightform Creator software. LF2 projects structured light "greyscale" patterns that are captured by the 4K camera. These patterns display for ~30 seconds and generate the Depth Estimate Map. LF2, generates a projector resolution depth estimate map, fills in holes, and wirelessly transfers the data back to your laptop in ~1 minute. Drag and drop instant effects in Lightform Creator, LF2's companion desktop content creation software. The interactive effects use the Depth Estimate Map to precisely map your scene. You can preview effects live from Creator or upload directly to the LF2. [22]

3.1.1.2. Dancing Water Speakers

Developed and marketed by the company Leading Edge, the Water Dancing Speakers have multi-colored jets of water that "dance" to the volume and beat of the music while the 6 multicolored LEDs create a visually engaging light and water show. The speakers stand 10.2' tall and are compatible with any audio device that has a 3.5mm audio jack or Bluetooth connection.



Figure 9 - Dancing Water Speakers by Leading Edge

3.1.1.3. JBL Pulse

The JBL HARMAN Pulse 4 Portable Bluetooth Speaker, is marketed as "Sound you can see". This speaker offers waterproof 360 degrees LED light show and speaker array. The JBL Connect App allows the user to change the sound-responsive colors and patterns and connect with other JBL PartyBoost compatible speakers to make them perform together. In order to connect the LED show with other nearby Pulse 4, simply hold the speaker nearby and shake it to sync up. Delivers up to 12 hours of music on a single charge. Pulse 4 is waterproof up to

three-feet deep. The speaker can function as ambient light without music being played.



Figure 10 - JBL Pulse 4

3.1.2. Works of Art

In the artistic world, commercial constraints no longer limit the variety and diversity of similar systems, and contrary to initial assessments, this made the research and selection process a very challenging task. There are no boundaries to what one thing is and when the other begins. There are probably thousands of art installations that capitalize on projection technologies to engage with visitors, and instead of projections and sounds being only part of specific works of art, many museums and galleries around the world are implementing immersive experiences within their architectures.

3.1.2.1. Projection One

Projection One strives to challenge the way in which users perceive projection art. Starting by changing the projection surface: take the traditional screen and cut it up into strips of variable widths, then rotate those strips to create a three-dimensional surface. adding depth to create a more volumetric or spatial experience out of the projection schemes. The overall surface measured approximately 13'(length) x 9'(height) x 3'(depth). They also have interactive control in the form of audio input and perhaps camera-based gestural reaction. [23]

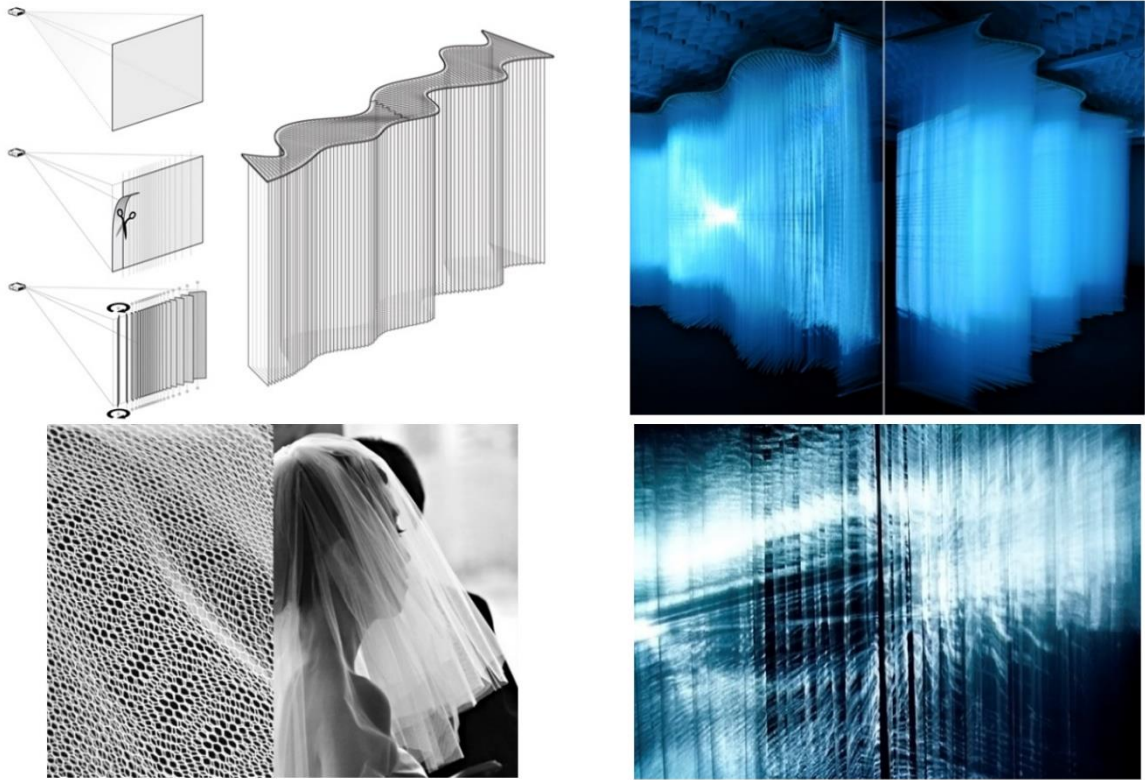

Figure 11 - Projection One: on top left is an image with the basic idea of the projection on strips of screen; on top right is an actual picture of the art installation; on bottom left is the close up of the material used for the screen, tulle, the same material used in wedding gowns; on the bottom right, is a snapshot of the art installation when projecting waves.

3.1.2.2. Bluetooth Speaker

The sculpture-like form of this alluring Bluetooth speaker is what sets it apart from the sea of devices within this product sector. The translucent housing conceals the inner workings beautifully, adding an element of suspense to the striking design. The visual interested is then taken a step further by the spherical base that it appears to rest upon, creating a surreal spectacle while remaining unobtrusive. Housed within the striking exterior are separate subwoofers and tweeter drivers, these ensure for a deep output and silky-smooth acoustics for a serene listening experience. User interaction has been carefully considered, leading to a design that is absent of obtrusive buttons and controls; a single rotating dial, that's located on the sphere, controls both the Bluetooth function and volume, allowing for intuitive control without any unnecessary buttons. [24]

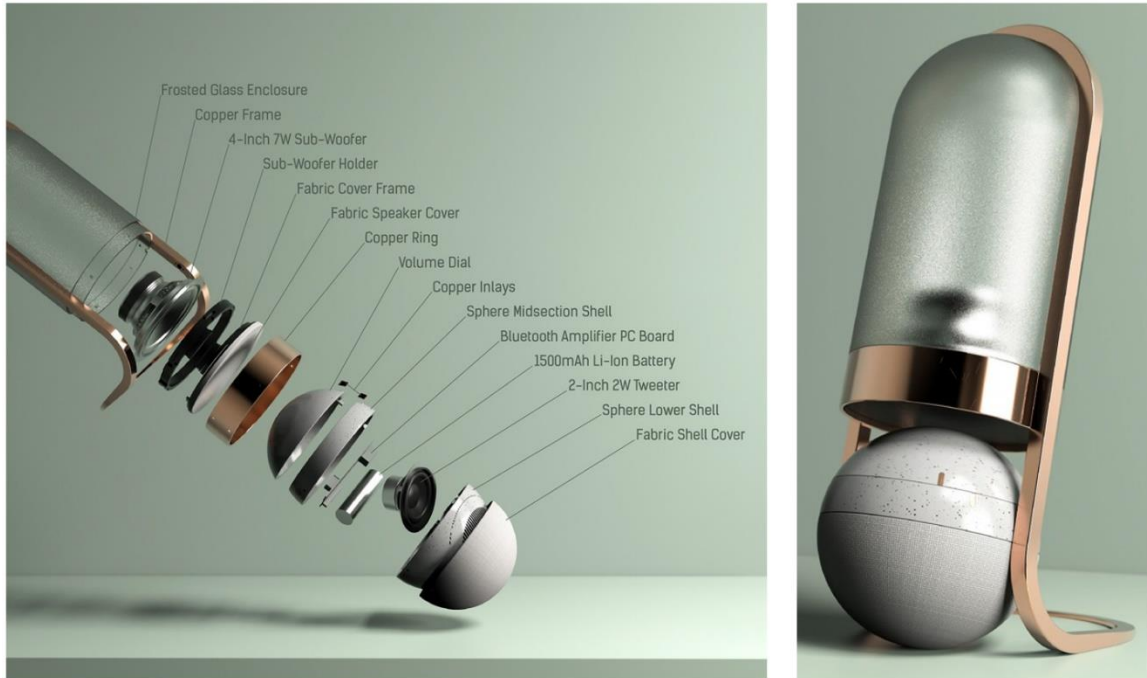

Figure 12 - Bluetooth Speaker Sculpture: on the left, the assembly breakdown of the parts, and on the right, the actual artifact.

3.1.2.3. Melting Memories

From February 7 through March 17, 2018, Pilevneli Gallery presented Refik Anadol's latest project on the materiality of remembering. Melting Memories offered new insights into the representational possibilities emerging from the intersection of advanced technology and contemporary art. By showcasing several interdisciplinary projects that translate the elusive process of memory retrieval into data collections, the exhibition immersed visitors in Anadol's creative vision of "recollection." "Science states meanings; art expresses them," writes American philosopher John Dewey and draws a curious distinction between what he sees as the principal modes of communication in both disciplines. In Melting Memories, Refik Anadol's expressive statements provide the viewer with revealing and contemplative artworks that will generate responses to Dewey's thesis. The following art installation is called Melting Memories and is based on the data collected from experiments that observe the waves in human brain when a person thinks of their memories and it is made by Refik Anadol. It was on display in Pilevneli Art Gallery in Istanbul. [25]



Figure 13 - Snapshot of Melting Memories by Refik Anadol, at the Pilevneli Art Gallery in Istanbul.

3.1.3. Engineering Prototypes

Exclusively taken from previous Senior Design projects at the University of Central Florida [26], the selection process focused on reviewing all projects with both visual and audio components. Out of the reviewed past projects, there were two that were considered relevant due to their use of lasers, LEDs, music, and medium.

3.1.3.1. Laser Musical Instrument

The objective of this project is to create a laser musical instrument that is new and novel. The laser beams will act as strings for the instrument. When a beam is interrupted by an object the reflected light is detected by photodiodes. Based on the intensity of the reflected light the pitch will then be determined for the note to be played. The laser instrument is intended to provide a new and entertaining way of approaching musical creativity at a reasonable price. [27]



Figure 14 - Laser Musical Instrument, still capture from video demonstrating functionality in a dark environment.

3.1.3.2. Dancing Water Display: An Audiovisual Spectrum Analyzer

The Dancing Water Display combines the concepts of water speakers and a spectrum analyzer. Using a Fast Fourier Transform to process audio signals and find frequency magnitudes, it is based on a water pump array to create a physical representation of a spectrum analyzer. The strength of the water jets varies according to their corresponding frequency band. It also includes LEDs that flash accordingly to an audio input to create a visually appealing show. Furthermore, the display includes a smartphone application that can control the power, light, and pump settings via Bluetooth connectivity. [28]



Figure 15 - Dancing Water Display: on the left, a still capture of a video demonstrating the water jets and LED illumination; on the right, the final product as presented to judges.

3.1.4. Summary of Similar Projects and Products

After reviewing the existing similar artifact concepts available online, a discrete set of points of interest arose.

- Having a software platform for artists to create visualization, could allow the product to be popularized independently, with little marketing investment.
- An AR projector could “understand” the surface it is projecting on.
- An AR projector price is about \$1,000.
- Key audiences for complex visualizations are retail stores and artists.
- Projection surface doesn’t have to be necessarily flat, or plastic.

- Adding depth to create a volumetric or spatial experience out of the projection.
- Adding depth to a projection surface only works if the material characteristics of the screen is transparent enough to allow for the light from the projector to pass through.
- Tulle might provide just the right amount of transparency and material density.
- Simple and minimalist design is visually appealing.
- Artisanal construction method and materials.
- Simple user controls stir the curiosity.
- Some optical technologies require eye protection, making them dangerous for the end user, and require special protective equipment.
- Using lasers might require a dark room for optimal viewing experience.
- Direct user interaction adds another complexity layer.
- The Fast Fourier Transform to process audio signals and find frequency magnitudes, might be exactly the best way to process our audio input.
- The use of water as the medium of visualization, adds layers of complexity on construction and maintenance.

3.2. Relevant Theories

In everyday use, the word “theory” often refers to an educated guess or untested hunch, without supporting evidence. But for scientists and engineers, a theory has a completely different and opposite meaning. A theory is a well-substantiated explanation of a characteristic of the natural world that can incorporate hypotheses, laws, and facts. For a successful orchestration of sound, light, and color, it is important to explore the theories available in regard to these aspects of the natural world.

In this section we describe the relevant theories to this project, including

- Color theory
- Music theory
- Harmonic theory
- Liquid crystal technology/lensing
- Real Time Systems

3.2.1. Color Theory – Additive vs. Subtractive

As it was the initial inspiration for this project, color mixing and synthesis is of huge importance to the success of this project. AUDIOVISIBLE needs to be able to produce color clearly and effectively from sound, conceivably across a majority of the visible spectrum. Unfortunately, we cannot just create an illumination system containing a single monochromatic source for every color in the rainbow, so we must turn to color mixing. Colors are commonly synthesized today using two common methods: Additive and Subtractive color mixing.

3.2.1.1. Subtractive Color Mixing

The simplest method of color mixing, coincidentally the first one (and for many people the only one) is called subtractive mixing. It's the color model we're all comfortable with, in which the primary colors are Magenta, Yellow and Cyan (but more intuitively Red, Yellow, and Blue). In this model, red and blue make purple, blue and yellow make green, red and yellow make orange, and so on. The more colors you add to the mix, the darker and "muddier" the color gets. It is the type of mixing we see with paints, crayons, even colored spotlights in large theaters all use subtractive mixing.

3.2.1.2. The Color Gamut

In the world of imaging and display technology, color representation has always been a hot topic of conversation among creators and engineers alike. What range of colors are we able to display? What method of color representation will we be using? How bright can we make the colors? All these factors and questions play directly into the action of choosing the primary illumination method. Most displays these days are built with either LED-based, LCD-based, or laser diode-based technologies. This includes LCD TVs and devices, OLED displays, RGB DLP projectors and so many more. The benefits and drawbacks of each technology vary, but they all play a central role in the representation of COLOR.

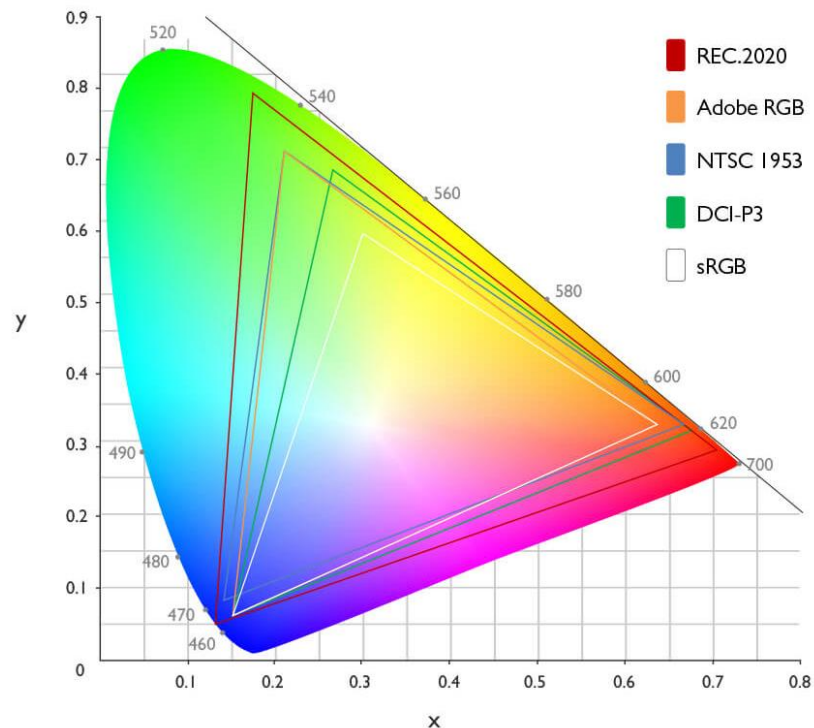

Figure 16 - Various Color Gamuts Plotted on CIE 1931 Chromaticity Diagram [29]

The color gamut describes the spectrum of color that any optical system can produce using the additive color method known as RGB. RGB displays are created using arrays of red, green and blue diodes whose output intensities are modulated

such that the mixing of their colors can be perceived as almost any color in the visible spectrum. The rounded shape above represents every color in the human visible spectrum and the triangles inside represent the displayable color for each of the listed display systems. At the corner of each triangle is the base color for red, green, and blue that each system uses (measured as a wavelength in nanometers).

Note that on the very edges of the curve are monochromatic wavelengths. The additive color model shows that the more monochromatic your light source is, the larger your gamut's triangle will be, and the more color your system will be able to display.

Our primary device for illuminating the projection optics and providing the color for our display will follow this exact construction. We intend to use the additive color system of RGB with semiconductor diodes. Our choices sit between a very small array of three to six laser diodes, or a larger array of colored LEDs.

3.2.1.3. Harbisson's Sonochromatic Scale

The nuance is with assigning colors to sound frequencies. Because music scales are cyclical (that is, each octave note is double the frequency of the next), it is possible to assign colors directly to notes for color representation. The plan is to use Neil Harbisson's Sonochromatic Music Scale [30] to assign colors, so in this instance Red (~450nm light) would be used to represent middle F (~174.6 Hz), Green would correspond to middle A (220 Hz). The true value of each displayed color will be calculated and converted using the color system HSV, which directly correlates to RGB. The device is expected to have a listening regime in the full bandwidth of the audible spectrum that is typically used in music (from about 20Hz to about 8kHz). The software needs to be fairly accurate in identifying each frequency within a couple of Hz. We are setting a sensitivity requirement 75%, meaning the device must be able to identify at least 75% of the frequencies it receives at any given time (within a couple of Hz).

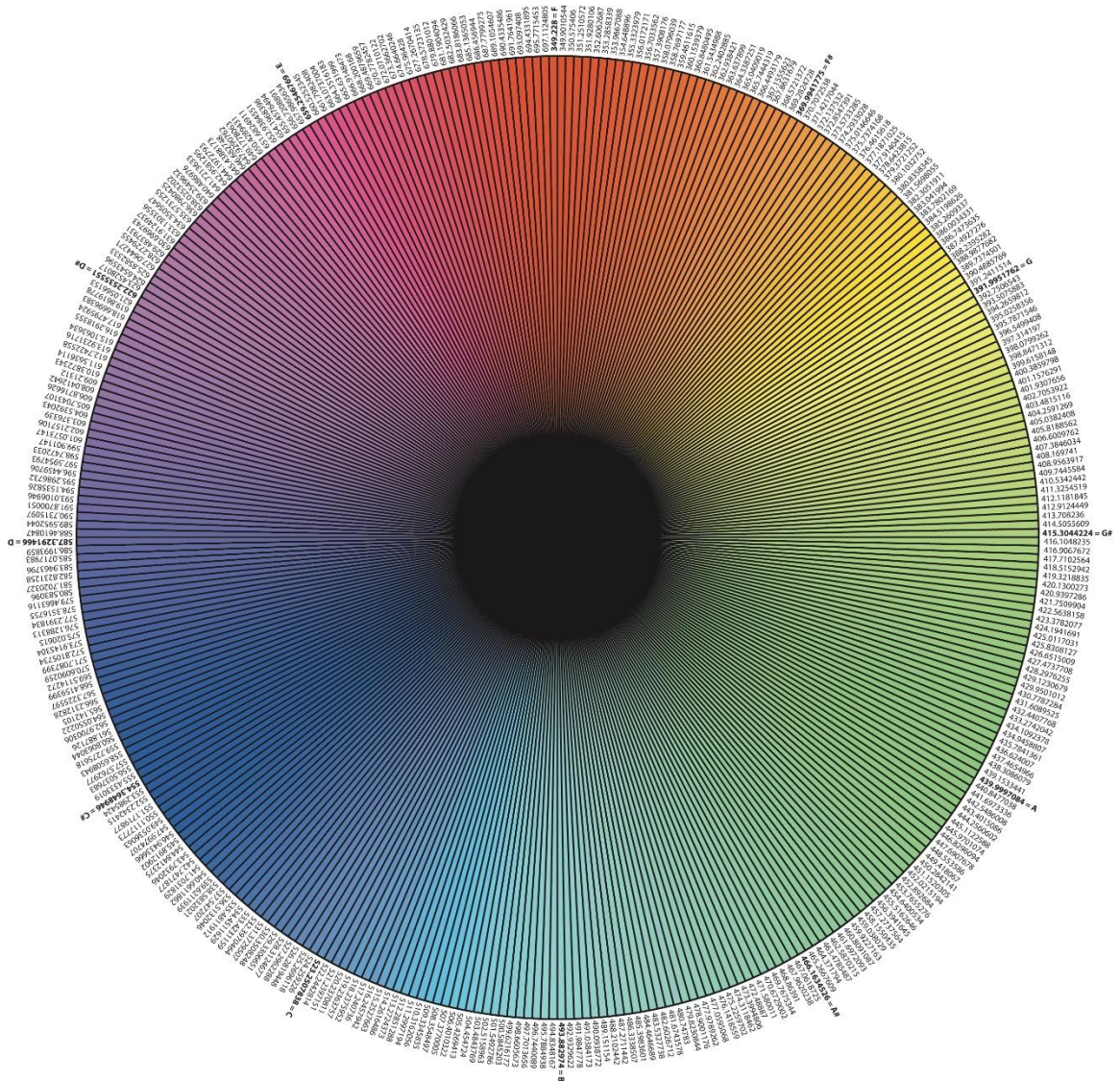

Figure 17 - Harbisson's Pure Sonochromatic Music Scale is a non-logarithmic scale based on the transposition of light frequencies to sound frequencies, which is used to convert visible color into an audible tone.

3.2.2. Music Theory

Tone is essentially the vibrational waves propagating to a normal range [31]. It has at least frequency and a collection of tones create an overtone. The lowest tone is called the fundamental. A melody is a group of tones assembled to create a composition in a distinct timing [32]. A composition is a collection of melodies that mesh well with one another. Melodies consist of pitch and duration [33]. Pitch is specified frequency area in the range of sound. Pitch can be used to determine the perfect sound of a note or instrument [34]. Timbre is the color of music, or the difference in pitch and tone between different instruments, thus each instrument producing its own unique sound [35] [36]. Volume, or loudness, is based off the amplitude, or size, of the wavelength of sound [37]. Duration is just the length of time that the sound is playing, or the sound wave is propagating [38]. Harmony is

when at least two notes are playing at the same time, thus also creating a chord [39]. Rhythm is when notes are placed in specific areas of time. The rhythm must stay on beat, or a certain pulse of the music. The tempo is how fast or slow the beat is, whether it be 90 beats per minute (BPM) or 150 BPM [40]. Dynamic is the volume, or amplitude, of a note. Two examples of dynamics are piano, p, or forte, f, that are placed under music staves [41]. Articulation is how melodies flow through a song, whether smooth or very separated [42]. Texture is how various musical compositions come together to dictate the quality of the section. Examples of texture are monophonic, one sound, or polyphonic, multiple sounds [43]. Music has four different forms: iterative, reverting, strophic, and progressive. Iterative form is when a phrase is looped over and over. Reverting form is when a phrase is repeated upon one that differs. Strophic form is when a melody is repeated to poetic lyrics of a song. Progressive form is when there is a constant addition of new melodies being inputted [44].

3.2.3. Harmonics and the Fourier Transform

The word “harmonic” refers to the analog frequency components of a time-varying signal, be it electrical, mechanical, or optical. Every signal, no matter how complex can be broken down into a superposition of a series of basic “harmonic” frequencies. This series of frequencies is known as the Fourier Series, and it is acquired by performing a Fourier Transform on the time-dependent signal in question. The idea is that if you add together an infinite number of simple sinusoidal waves, alter each one’s amplitude and frequency just a bit, you can create any time-dependent signal.

In the context of this Senior Design project, we are interested in taking any musical input (which is by definition: a time-dependent signal), performing a Fourier Transform on it and taking record of the largest-contributing harmonic frequencies at any given time. This harmonic data will then be used to define values for our color and image output.

3.2.4. Optical Lensing

When light is incident on any surface at all, be it refractive, reflective, or even opaque, it affects the behavior of the light in various ways. Refractive surfaces bend the light, reflective surfaces turn the light right back where it came from, and diffractive surfaces disperse the light in strange and in some cases predictable and useful ways. “Optics” is the term used to describe the components and devices used to focus, defocus, manipulate and direct light from one place to another, using these principles. They are used to create and record images, illuminate rooms or objects, and transmit and transform data coming from one place on its way to another. In this section we will discuss two completely different types of optics: Refractive Optics and Diffractive Optics.

3.2.4.1 Refractive Optics

As far as the general public and laypeople are concerned: lenses are transparent or translucent pieces of glass that focus light. They function because they have a certain thickness and a specific curvature that cause the light to bend in a specific,

predictable, and repeatable manner as it passes through. The glass (or sometimes plastic) they are made of is a homogenous, isotropic medium, meaning it is completely the same material and structure throughout the lens. These characteristics describe what is known in the field of optics and photonics as Conventional Optics: the oldest form of optics used and studied in all of human history. Your commercial camera lenses, bathroom mirrors, even your eyes qualify as devices that use conventional optics to function.

Conventional optics are able to function due to differences between mediums in a quality known as the “Refractive Index”. As light passes from a material with a low refractive index (for example: air) and into a material of higher refractive index (glass, water, oil), the light slows down and changes direction. The amount by which it does these two things is entirely dependent on the magnitude of the difference of the refractive indices of the two materials. You see this phenomenon in action every day: when the surface of water distorts your view of something beneath it, when your glasses shift the apparent location of an object relative to your eyes when you put them on. It is because of this relationship to the refractive index that conventional optics are also referred to as “Refractive” optics.

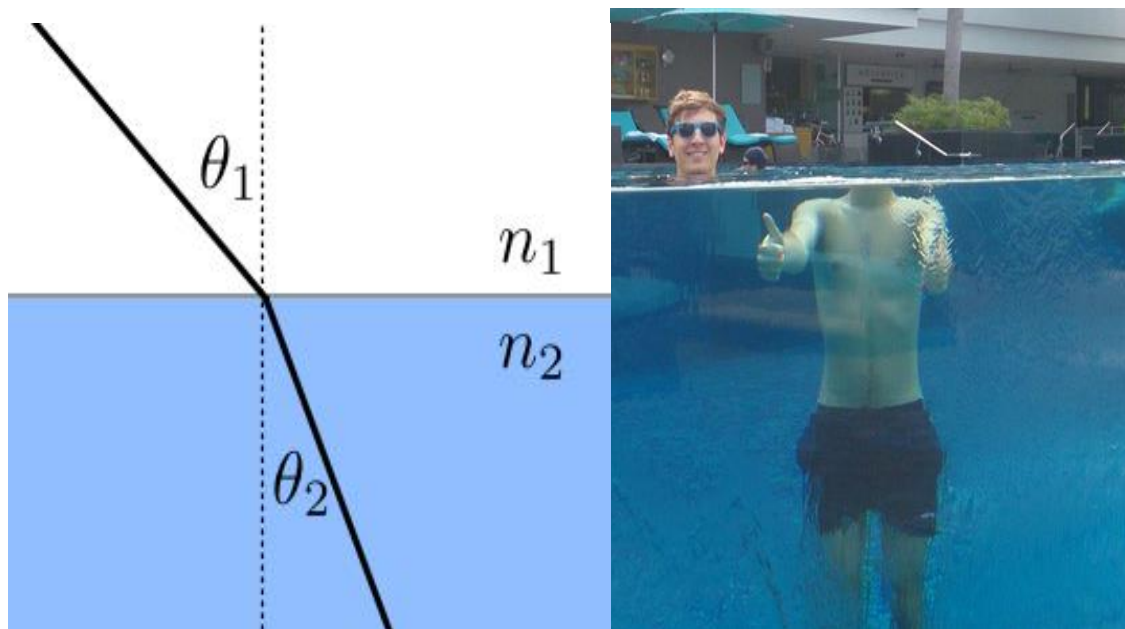

Figure - 18 Example of refractive optics at work. Image on the left shows light incident on an interface between two different refractive indices. As it crosses the border into the higher refractive index (labeled n_2), its direction of propagation bends toward the normal of the boundary between the two mediums. Image on the right shows this principle at work on a (still living) young man in a swimming pool with a transparent wall. [45]

When light crosses into a medium of higher refractive index (as shown in figure 18), its direction of propagation bends toward the normal to the surface it has just passed through a trigonometric relation known as Snell's law [46]. That is to say that the angle of incidence on either side of the medium is trigonometrically scaled by the difference in the two media. The greater the difference in refractive index, the more the light bends, and therefore the greater the difference in the angles denoted

above as θ . More interestingly, the greater the angle of incidence that the light has on the interface, the more it bends. The latter principle is regularly applied with lenses.

When light impinges on different spatially-varying parts of a **curved** surface [46], the angle of incidence is different for each ray, causing them to diverge by different amounts, allowing for the focusing and de-focusing the light depending on the curvature of the lens in use. This simple geometrical relationship is what has enabled the use of refractive optics at all, in every application. question.

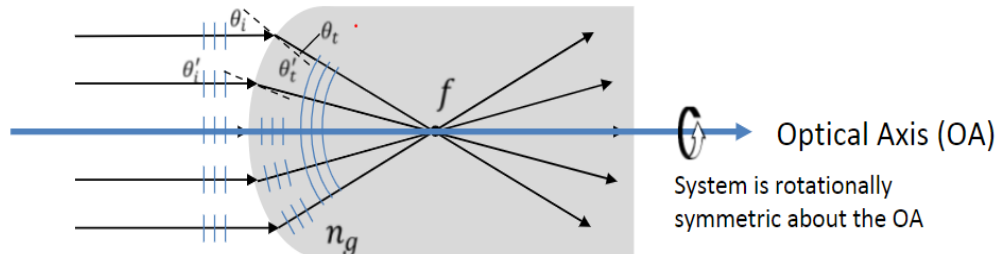

Figure 19 - the greater the angle at which light impinges on a refractive surface, the more it bends. This allows for the design of lenses that can focus light focus light to one point [46]

The benefit of refractive lenses is that aside from the (often negligible) loss of light due to reflection, glass optics in the visible spectrum are generally broadband. That is to say: all the light that is incident upon a refractive optic is passed through and used in the system, regardless of the wavelength or the polarization of the light in question. It is because of this that refractive lenses are the most common lenses found in most settings including commercial, military, and academic. They have been around for centuries and are therefore familiar, well studied, well documented and widely manufacturable.

The biggest drawbacks of refractive optics in practical settings are their size and their weight [47]. As their power depends on their curvature, refractive optics can get very bulky, and therefore very heavy. Furthermore, because they require a rigid shape in order to work, a singular lens is not very versatile, and must be replaced if you require different focal lengths or directions for your light.

3.2.4.2. Diffractive Optics and Liquid Crystals

Much more recently developed technology in the field of optics and photonics in the past few years has been diffractive optics. As one can deduce from the name, where refractive optics operates off the principle of *refraction*, diffractive optics operates on the principle of *diffraction*. When light is incident upon any surface or medium, it has the tendency to disperse and bend around, through, and/or away from said surface. Diffraction is the term used to describe the bending of light that is not due to reflection or refraction [48].

In this section I will discuss how diffraction works on planar surfaces, diffraction gratings, and how liquid crystals are used to create diffractive lenses.

3.2.4.2.1 Diffraction Gratings

A common device used in optics is a diffraction grating. As the name implies, it is an optical grating intended to induce the diffraction of incoming light. A grating can be conceptualized as a series of very small, **equally spaced** slits in an otherwise opaque material. Due to the wave nature of light, when it passes through a single slit, the slit acts as a point source of for the light passing through it and light (or any wave for that matter) will radiate away from the wave in a circular shape (as shown below). Gratings take this phenomenon to the extreme. When light is incident on a grating, it creates a series of point sources dispersing light in all directions. The many individual waves that propagate away from the grating begin to interfere with one another.

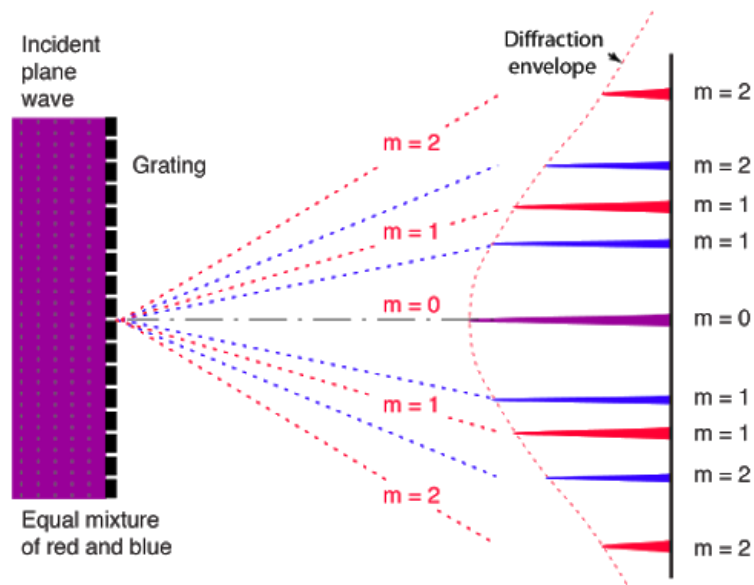

Figure 20 - Diffraction depicted. On the left: Light diffracting through a single slit, behaving as a point source of light. On the right: The diffraction pattern seen when light is incident on many different slits (i.e. a grating)

The interference of these waves actually forms fairly linear behavior, in the sense that the positive interference-produced waves travel in nearly straight lines. The angles and distances at which these rays propagate are highly dependent on the wavelength of light passing through them, and their behavior has been studied extensively, such that we can design gratings in order to control and manipulate this phenomenon.

3.2.4.2.2. Diffractive lenses

If we manipulate the size and spacings of the slits in a grating (known as the pitch), we can manipulate the diffraction pattern so that instead of creating a dispersive effect (as shown in the figure in the previous section), we see a focusing effect (as shown in the figure below). As you can see in Figure 21 below, the pitch in the diffractive lens decreases as it gets farther from the center of the lens.

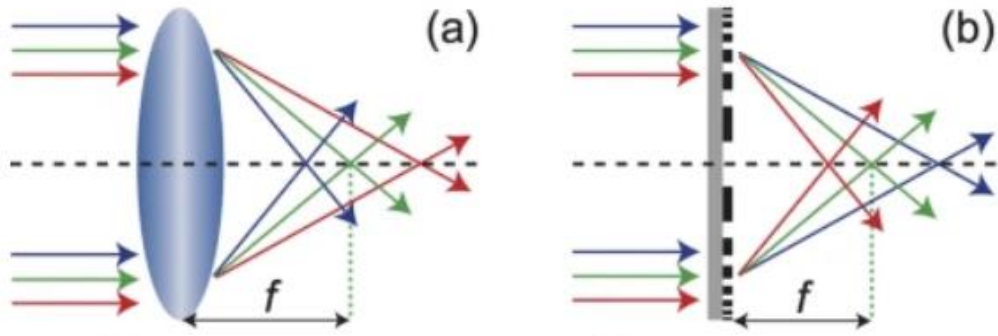

Figure 21 – Depiction of a refractive lens and its analogous diffractive lens Left: Conventional refractive lens of fixed thickness and curvature. Right: Diffractive grating designed for the focusing of light. Note the significant reduction in thickness of the lens when comparing it to its predecessor [49]

The smaller the pitch of the lens, the greater the angle of deviation seen by the light, the more focusing power the lens can achieve. This means that the power of the lens is no longer dependent on its thickness or curvature, its power is completely dependent on the quality of the grating etched onto it.

3.2.4.2.3. Liquid Crystals

This is all good and well, but in order for these lenses to work, the pitch on the grating needs to be on the order of *microns* in order for the lens to be any good. We can't just sit there and poke millions of micro-sized slits in a piece of paper or glass, and we can just cut rings out of them either. Even if you were to scratch ridges onto a glass surface, imperfections in the etching would hinder the component from achieving a reliable optical effect. This is where liquid crystals come in.

Liquid crystals have been described as materials that behave in an in-between state from liquids and crystalline solids [50]. They flow much like a liquid, but their molecules tend to arrange in specific, crystalline orientations relative to one-another. They can be conceptualized as elongated molecules in a solution that have a tendency to align on top of one-another. Because of this behavior, liquid crystals can be laid on any surface and align to its topography, creating a quasi-crystalline film, replicating the topological structure.

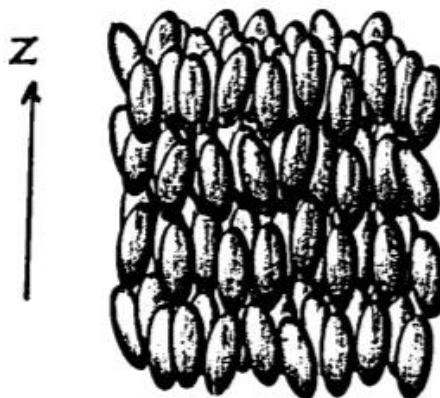

Figure 22 - Liquid crystal molecules aligned in the z-direction

On top of being able to align in a structure, liquid crystals are *birefringent*. This means that light incident upon a liquid crystal experiences a different refractive index depending on the angle and polarization of the incident light. Simply put, liquid crystal is able to allow one linear polarization while completely blocking the orthogonal polarization. By aligning the liquid crystal in alternating patterns, and passing linearly polarized light through it, the crystal structure acts as a grating. As we already discussed above, all we need to do know is arrange the crystal grating in a circular structure, with pitch increasing further toward the edges of the lens.

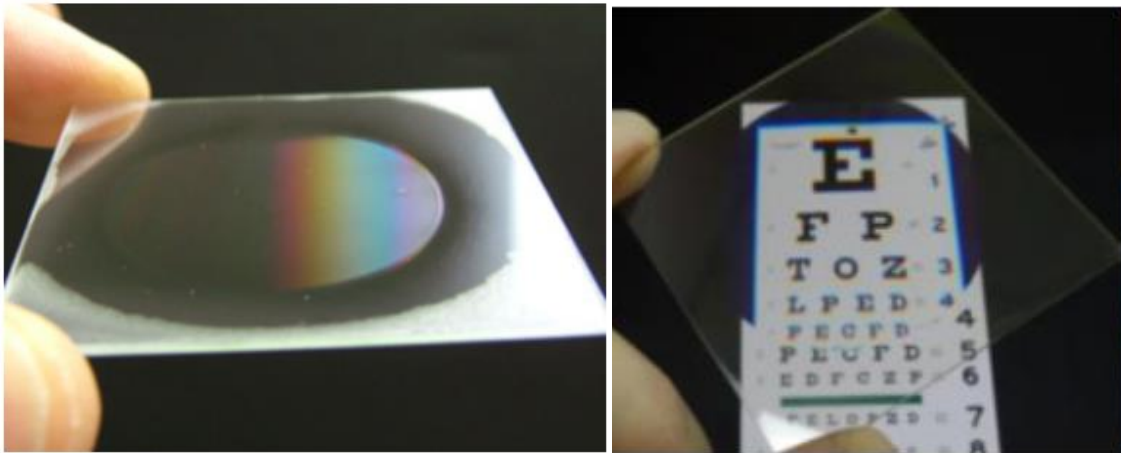

Figure 23 - Actual diffractive waveplate lens made from liquid crystal polymer, produced locally by BEAM Engineering Co. in Orlando, FL [51]

The greatest benefit of these lenses is their size and versatility. They are incredibly lightweight, as the thickness of the liquid crystal film required to make them is typically on the order of 1-5 μ m [51]. That means that the lens is very nearly the width of the glass substrate you put it on. They are relatively low-cost to produce and can be tuned to lens any wavelength in the visible spectrum [47]. The biggest drawback of these lenses is that they experience a fairly high amount of chromatic aberration, meaning they are only practically effective at lensing monochromatic light sources at the moment, but design and fabrication processes to make them more broadband are on the horizon [47]. For the purposes of this project, however, we may only be interested in lensing monochromatic sources, so these still pose a great option.

3.2.5. Real-Time Systems

Systems that perform functionality on a continuous basis are essential for the advanced collection and production of new data [52]. There are three types of real-time systems: hard, soft, and firm. Hard real-time systems are where there are strict guidelines that must be followed, otherwise a malfunction will occur. Soft real-time systems are where there are lower expectations of deadlines but in the end, it may ruin quality, such as lag in audiovisuals, which this project focuses on. Finally, firm real-time systems are when a guideline is missed but quality may still degrade [53].

A device used to assist in computations and real-time aspects of this project is the Raspberry Pi, a mini-computer able to perform simplistic desktop functionalities able to run Linux OS and priced at a cheap cost. The Raspberry Pi has a real-time operating system (RTOS) that can be added on, called ChibiOS/RT, that can support functions that cannot be processed on PCBs, like kernel operations, analog-to-digital conversions, and a real-time clock. It has a lower latency than Linux. The Raspberry Pi will be operated to handle basic neural networks and buffering commands [54]. As the audio is being processed into a visual, there is a required buffer time to prevent lag and timing miscalculations. A delay or waiting period will be directed so that way each clock edge matches to real-time.

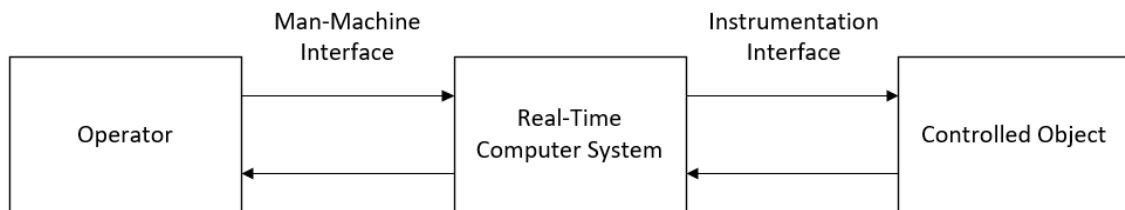

Figure 24 - Real Time System Diagram

3.2.6. DSP Fundamentals

Digital Signal Processors (DSP) take signals like voice, audio, video, temperature, pressure, or position, that have is digitized and then mathematically manipulated. A DSP is designed for performing mathematical functions like "add", "subtract", "multiply" and "divide" in a short period of time. The signals need to be processed so that the information that they contain can be displayed, analyzed, or converted to another type of signal for them to be used.

Analog products detect signals such as sound, light, temperature or pressure and manipulate them. An ADC takes the signal and turn it into a digital format of 1's and 0's. Afterwards, the DSP captures the digitized information and processing it. It then feeds the digitized information back for use in the outside world. It does this in one of two ways, either digitally or in an analog format by going through a DAC. All of this occurs at very high speeds.

A DSP's information can be used by a computer to control such things as security, telephone, home theater systems, and video compression. Signals may be compressed so that they can be transmitted quickly and more efficiently from one place to another. Signals may also be enhanced or manipulated to improve their quality or provide information that is not sensed by humans. Although real-world signals can be processed in their analog form, processing signals digitally provides the advantages of high speed and accuracy.

The Raspberry Pi is equipped with the DSP functions, so we will use that device to assist with the analog to digital conversion. The AUDIOVISIBLE device will be sending signals at high frequencies for the projection so the DSP will be required. [55]

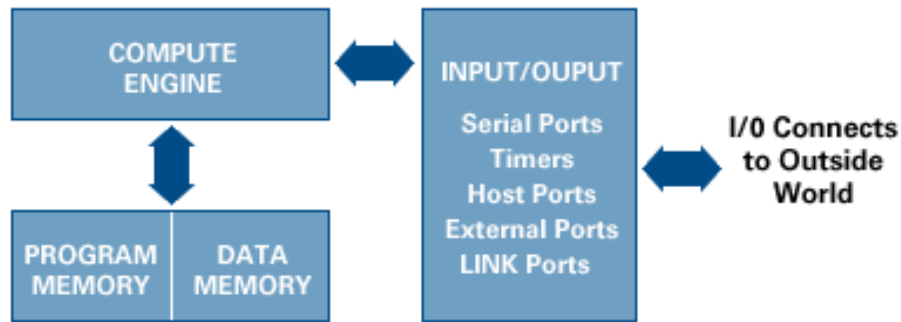

Figure 25 – DSP Key Components

DSP Key Components:

- Program Memory: Stores the programs the DSP will use to process data
- Data Memory: Stores the information to be processed
- Compute Engine: Performs the math processing, accessing the program from the Program Memory and the data from the Data Memory
- Input/Output: Serves a range of functions to connect to the outside world

3.3. Strategic Components and Part Selections

Regardless of what the block diagram states, this section is a broad attempt at covering multiple different parts, contrasting and evaluating various options. It is important to cover the main parts and electrical components, as well as some of the internal processes that might be implemented in AUDIVISIBLE.

3.3.1. Optical Module

The optics required to create a projector may be very complex or very simple depending on the intended purpose and the available parts. The simplest form of a projector can be made with an image and two lenses [56]. Since our project needs to both illuminate, produce AND project an image, our optical system must be fairly complex, while still being very compact.

AUDIOVISUAL's optical module will consist of a light source providing a spectrum of light broad enough to create white light, a lens system to focus the light onto a Digital Micromirror Device (DMD), and a lens system to project the images produced by the DMD onto a viewing screen. In this section we will discuss the various options for illumination of the system, directing the light through the system, and projecting the image outward.

Because of the complexity of a projection system, we will opt for a completely assembled optical system for our projector. In this section, we will first identify which characteristics our optical module needs to have, and then discuss the options of complete optical modules which meet our needs.

3.3.1.1. Illumination

There are various kinds of light sources used in projection technology today. They include incandescent white light sources -such as metal halide lamps and Ultra High Performance (known as UHP) lamps- and additive RGB diode light sources like Light Emitting Diodes (LEDs) and Laser Diodes. They are all in use today for various purposes and reasons, and each type of illumination offers its own benefits and draw-backs. In this section we will explore each illumination technology and its potential for use in AUDIOVISIBLE.

3.3.1.1.1. White Light Sources

Incandescent white light sources such as Metal Halide and UHP lamps have been used as the illumination sources in overhead projection devices since as early as the 1960s [57]. They make for great illumination devices in the sense that they are very bright and offer an emission bandwidth spanning the entire visible spectrum. So in order to get any particular color, they simply need to have a colored filter in front of them and every other color will be absorbed.



Figure 25: Incandescent white light sources. Metal Halide Lamp (left) and UHP Lamp (right)

Incandescent sources, although bright and broad, have a relatively short lifetime (about 3,000 hours of operation) and are not very efficient light sources compared to newer illumination technologies. They consume a significant amount of power (The Philips shown above operates at about 150W) and they tend to generate a lot of heat, therefore requiring a cooling system or heat sync for extended usage. Lastly, due to the fact that they provide only a wide bandwidth of light, they require an entirely separate system for color selection and projection if you want to create a color image.

3.3.1.1.2. Laser Diodes

Solid-state semiconductor laser diodes would be an excellent choice for illuminating AUDIOVISIBLE. They allow for very bright, coherent and monochromatic illumination for use in projection optics. They are highly directional and therefore produce more usable light in the system. This makes them more efficient in the sense that they produce more usable light, but they do require more electrical power to drive than LEDs, as they need to achieve a threshold of lasing. Despite this however, laser diodes are still very efficient light sources compared to their incandescent and fluorescent counterparts. Furthermore, once a laser diode has achieved its threshold operating current the output intensity shares a linear

relationship with current, making it very easy to control the laser's output "which we would need to do for color synthesis).

One pivotal drawback of using laser diodes is their cost. Although red laser diodes have been around for decades and are very low in cost (as low as three dollars for one diode), blue laser diodes are more expensive at nearly ten dollars, and the cost of green laser diodes makes them almost unobtainable with the cost constraint for this project, unless we receive funding from an outside source.

3.3.1.1.3. Light Emitting Diodes (LEDs)

LED's and their related technologies have been taking the field of imaging and display technology by storm for the past several years. They are used in computer screens, TVs and more recently are now being used to replace incandescent and CFL lightbulbs for home lighting. They are more electrically efficient than the aforementioned technologies and are capable of producing very broad bandwidths of light compared to their lasing counterparts. LED's however do lack in the sense that the directionality of their emission is significantly lower than that of a laser diode, the spectral linewidth of the beam is usually much broader, and because of the radial behavior of the LED's output pattern, the irradiance of LEDs (output power per unit area) is much lower than a laser diode. The attractiveness of LEDs of course lies in their low cost and high electro-optical efficiency. They lack in the sense that they don't produce very monochromatic light, meaning their color spectrum when used for RGB mixing would not be as broad as that of a laser RGB system.

LEDs also come with the added benefit of being obtainable as pre-packaged arrays at low cost.

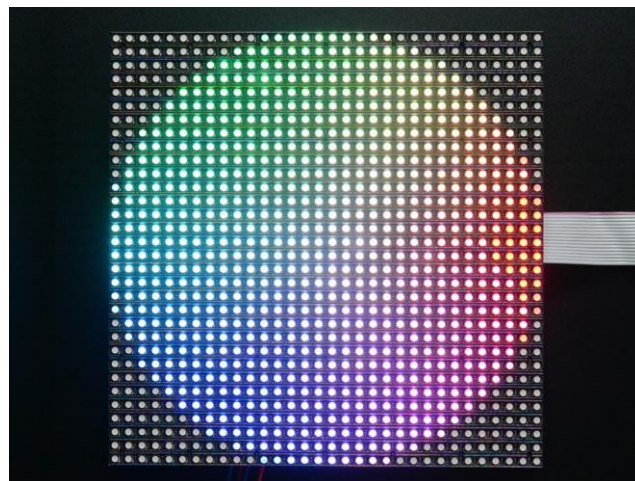

Figure 26 pre-assembled LED Array

3.3.1.1.4. Conclusion

Although cost is of large importance to us as students, color is one of this project's most important features. Incandescent white light sources are completely out of the question as they would require an entirely new, separate, mechanically intensive system for color representation. The decision was between laser diodes

and LEDs. Although LEDs are cheaper and have comparable electrical efficiencies to laser diodes, they lack in monochromaticity and directionality of light. We would need much more LEDs, more powerful lenses to compensate for the very fast divergence of the LED emission, and would get a less chromatically versatile image out of the system than we would with laser diodes, making laser diodes our best bet for achieving AUDIOVISIBLE’s goal.

Features	White light source	Laser Diode	LED
Relative Size	Large	Small	Small
Relative Weight	Very heavy	Very light	Very Light
Cost (per bulb)	\$60-\$200	\$3-\$108	\$0.6-\$8
Illumination	>2,000 Lumens/bulb	0.5-100W	20-122 lumens/bulb
Power consumption	150W	0.5-100W	0.05-1W
Color selection	Needs color filter	Monochromatic	Can be broadband

Table 2 - Illumination Comparison.

3.3.1.2. Beam Homogenization

Once we’ve selected our light source, the beam used for illumination needs to be homogenized for use on the DMD. In white light sources, this is not an issue because all the light is coming from one source. However, for our Intended RGB setup, the three different colored beams must be combined well enough such that chromatic aberration doesn’t ruin the focusing of different colored lights.

Dichroic Mirror Setup

In many expensive RGB illumination systems for projectors, the different colored beams are produced in different places and combined using lenses and dichroic mirrors as shown in figure ___ below, taken from ViewSonic’s website.

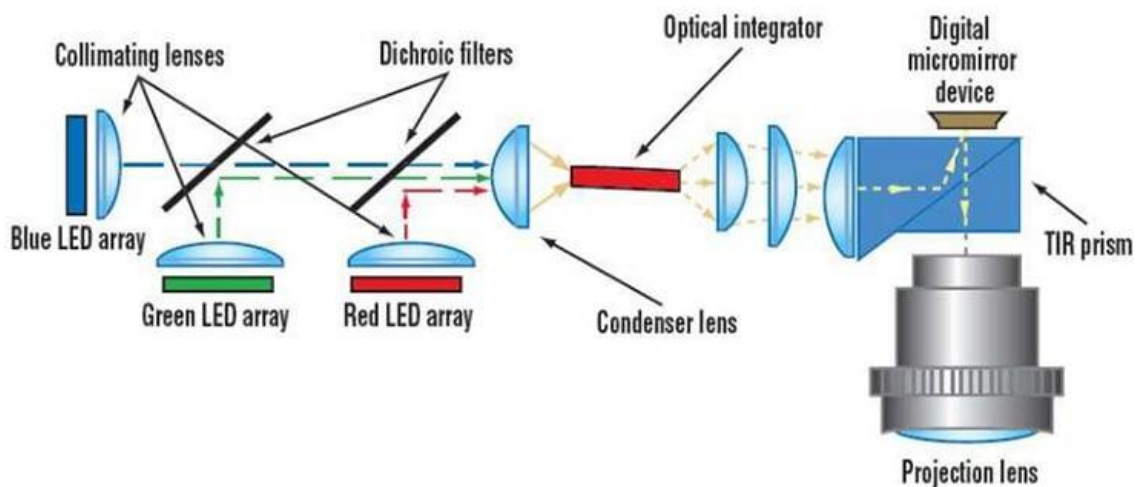

Figure 27: Generic Schematic for a DLP projector taken from ViewSonic. Note the system for combining Red, Green, and Blue light sources into one homogenized beam [58]

These designs can get more and more complicated depending on your demands for resolution, contrast, etc. This can get very expensive very quickly, as each light

source needs its own collimating lens and a dichroic mirror before light can even be focused into the TIR system.

Once the light is all pointed in one direction, it is then focused using a condenser lens directly into a beam homogenizer. In the case above, it is labeled as “optical integrator”. This homogenizes the three beams into one homogeneous beam, which is then used to illuminate the DMD and create the images for the projection. The Homogenizer is critical in the process of focusing of light onto the DMD. There are two options for homogenizers: a tube lens and a fly’s eye lens array. Either one would work for our purpose, so we’ll briefly outline what they are and then move on.

Tube Lens Homogenizer

One method of beam homogenization is via a tube lens (labeled above as “optical integrator”). The attractiveness of tube lenses is that they are one single optic, so there is no need to worry about the placement/alignment of several lenses in an array. They come in many shapes and sizes, and are selected based upon their shape, length and Numerical Aperture. The Numerical Aperture (NA) describes the largest angle at which light can enter an optic, depending on the diameter of its entrance pupil.

Fly’s Eye Lens Array

A fly’s eye array is a two-dimensional array of individual lenses used to turn a non-uniform illumination from different sources into a uniform distribution [59]. A fly’s eye lens array works similarly to a tube lens in that it collects and combines different beams of light, but instead of it being one optic, it is a (usually large) number of them working in tandem.

3.3.1.3. Image creation: Digital Micromirror Device

Once the illumination has been homogenized and integrated, it must be directed onto/through a device that will actually create the image that will be projected out of the system. A Digital Micromirror Device (or DMD) is the pivotal technology in the field of Digital Light Processing and Projection [60]. It is an electrically-controlled, two-dimensional array of very small, individually and digitally-controlled mirrors which are highly reflective in the visible spectrum and each only taking up a few microns in surface area [61]. In order to produce an image, uniform light is directed onto the entire surface, and the mirrors are moved to either reflect the light out through the intended light path of the system (producing the image) or away from the light path onto a secondary surface (subsequently creating a “negative” or “inverse” image).

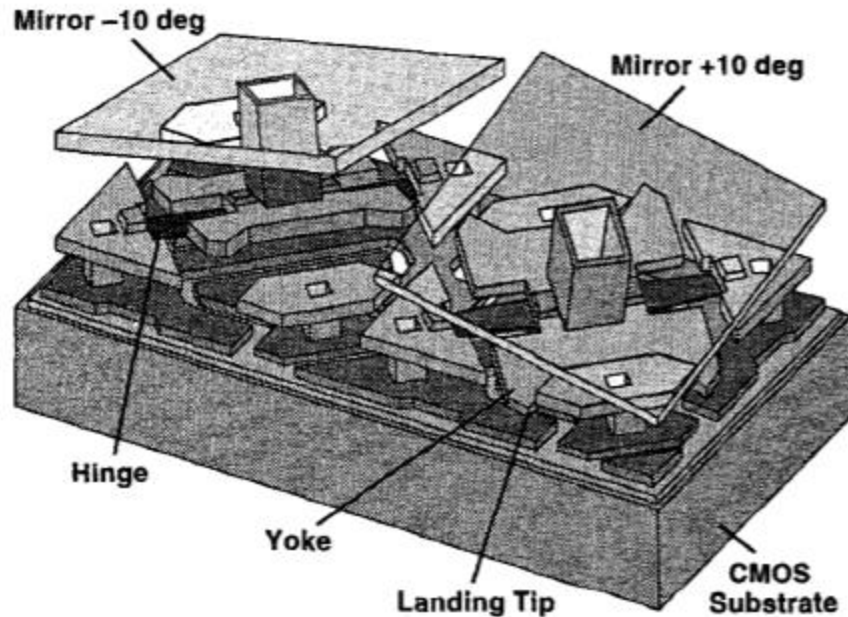

Figure 28: Two DMD pixels, each mirror is shown to be transparent. Note how they are pointing in two directions: positive and negative 10 degrees, indicating that these are the “on” and “off” states for this DMD [61]

DMDs are a trademarked technology invented and owned by Texas Instruments, and are marketed and sold as “DLP chipsets” [60]. In this section we will discuss several different DLP chipsets sold by Texas instruments, their pixel resolution, and what that means for us and our need for “high resolution”. We will discuss the pixel counts for nHD, WVGA, 720p, and 1080p resolutions. Each of these requires an increasing number of pixels and therefore, by definition, produces “better resolution”.

nHD is a display resolution of 640×360 pixels, which is exactly one ninth of a Full HD (1080p) frame and one quarter of a HD (720p) frame. Doubling the pixel count in both the vertical and horizontal directions of one nHD frame will form one 720p frame and tripling the pixel count of an nHD frame will form one 1080p frame. One drawback of this resolution regarding encoding is that the number of lines is not an even multiple of 16, which is a common macroblock size for video codecs. Video frames encoded with 16×16 -pixel macroblocks would be padded to 640×368 and the extra pixels would be cropped away at playback. H.264 codecs have this padding and cropping ability built-in as standard. The same is true for qHD and 1080p but the relative amount of padding is more for lower resolutions such as nHD. To avoid storing the eight lines of padded pixels, some people prefer to encode video at 624×352 , which only has one stored padded line. When such video streams are either encoded from HD frames or played back on HD displays in full screen mode (either 720p or 1080p) they are scaled by non-integer scale factors. True nHD frames on the other hand has integer scale factors, for example Nokia 808 PureView with nHD display.

3.3.1.3 Conclusion

After much research and deliberation, we realized that a projection system may have been too ambitious of a project for one photonic engineer to tackle alone within a short amount of time and with the cost constraints that the typical college student has to operate within. It is with this knowledge that we decided in order to have a good, reliable projection system that will effectively enable the success of our overarching goal, we will move toward purchasing a completed DLP projection module and modify it to better fit our needs.

3.3.2. Optical Engine Selection

Now that we have discussed optical specifications and decided to modify a completed module, we've identified four optical engines that use DMD technology and may work well for our purposes. They are all dubbed "DLP Evaluation Modules" or "EVMs" and are produced by Texas Instruments: the DLPDLR2000 EVM, the DLPDLR2010 EVM, the DLPDLR3310 EVM and the DLPDLR4710 EVM. Each module is named after the DMD chipset it is designed and optimized for. Many of them already come fully stocked, ready for plug-and-play, containing all the necessary illumination LEDs, dichroic mirrors, homogenization optics, prism systems and projection optics.

In our research, we found that due to immense cost disparities, some serious compromises were going to need to be made in order to achieve a finished product. Below is a summary of what we found.

Every module comes equipped with

- Optical Engine
- Illumination LEDs
- Optimized PCB
- DMD Flex cable for output control
- Beaglebone Black compatibility
- Some direct microcontroller or Raspberry Pi compatibility

3.3.2.1 DLPDLR2000 Evaluation Module

DLPDLR2000 Evaluation Module is the most basic DMD/optical engine kit available for purchase from Texas Instruments. Optimized for the DLP2000 DMD (the smallest Pico™ chipset produced by Texas Instruments) it is the most economically viable option for this project, costing just \$99.

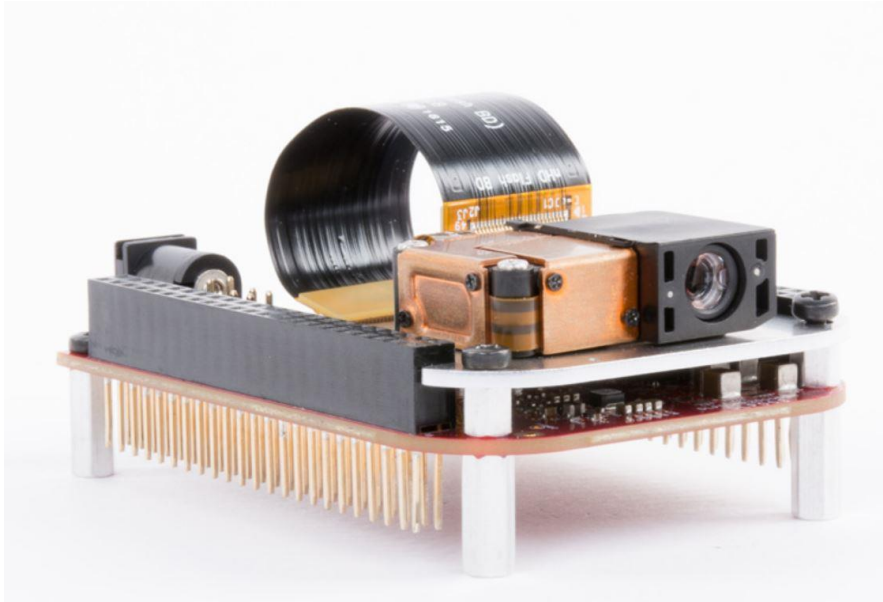

Figure 29 Texas instruments DLP2000 Evaluation Module

The DLPDLCR2000 EVM touts the display resolution of TI's smallest Pico™ chipset and is not very bright. Where it does grab attention is it's incredibly compact size, low cost, low power consumption, and easy installation/integration.

Specs:

- Dimensions: 54x76mm
- Illumination brightness: 30 Lumens
- Power Supply: 5V DC 3A Max
- DMD Resolution: 640x360 (nHD)
- Throw Ratio: 1.6
- Cost: \$99

3.3.2.2 DLPDLCR2010 Evaluation Module

The runner-up for optical module is the DLPDLCR2010 EVM. Optimized for the DLP2010 chipset, it is the second smallest, and second cheapest DLP EVM produced and sold by Texas Instruments.

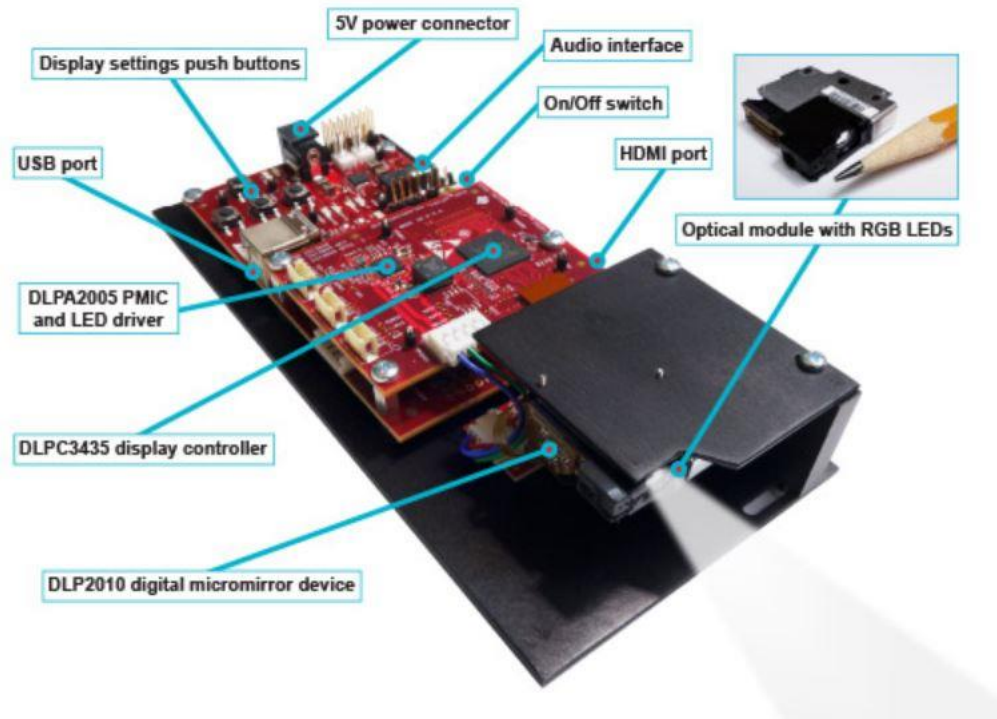

Figure 30 Texas instruments DLP2010 Evaluation Module

The DLPDLCR2000 EVM touts the display resolution of TI's second-smallest Pico™ chipset, and about as bright as the 2000 EVM. It improves on the 2000 EVM by having a higher resolution, more advanced PCB and LED driver, push buttons for display settings and a more complex optical module. Unfortunately, this model isn't TI's flagship model, the optical engine is produced by a third party company, inflating the cost significantly.

Specs:

- Dimensions: 45x43x12mm
- Illumination brightness: 25 lumens
- Power Supply: 5V DC 3A Max
- DMD Resolution: 854x480 (WVGA)
- Throw Ratio: 1.3
- Cost: \$499 [62]

3.3.2.3 DLPDLCR3310 Evaluation Module

The DLPDLCR3310 is the best higher-priced evaluation module for our purpose that is available from Texas Instruments. Intended for much larger and ambitious projects than our own, the DL3310 is larger, has a higher resolution than the previous two options and has the best Throw Ratio out of the options we've seen so far.

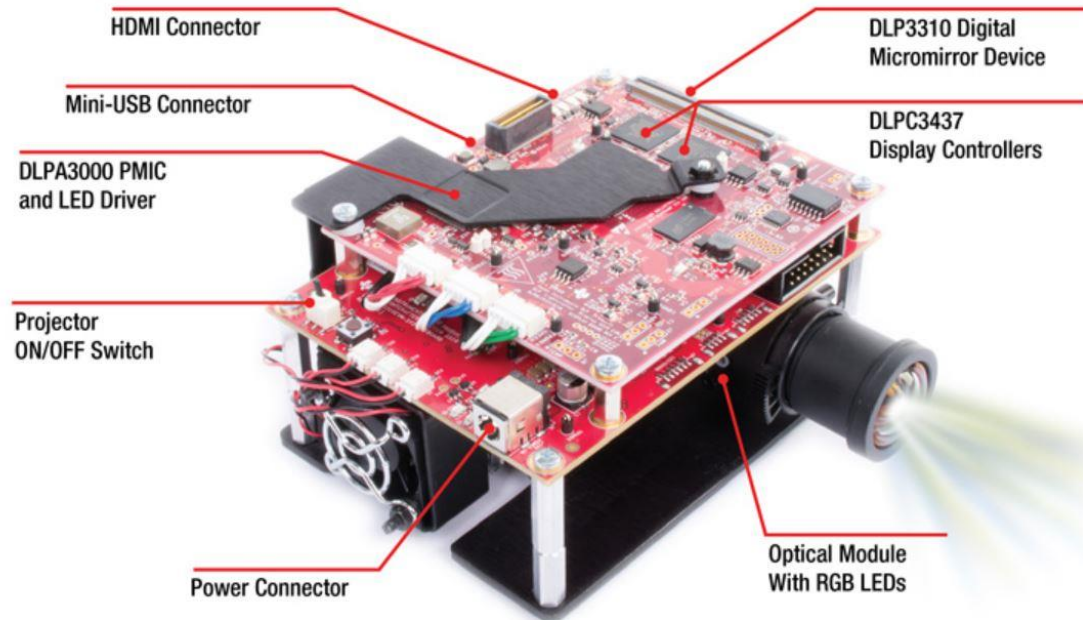

Figure 31 Texas Instruments DLP3310 Evaluation Module

The DLP3310 has a very high resolution of 1080p and requires a significantly higher power source than the previous two options. Furthermore, because its size and power consumption, this module tends to generate a lot of heat and therefore requires a heat sink and fan assembly inside of it. It runs for \$849 on Texas Instruments website.

Specs:

- Dimensions:
- Illumination brightness: 300 lumens
- Power Supply: 19V DC 3.42A
- DMD Resolution: 1920x1080 (1080p)
- Throw Ratio: 1.2
- Cost: \$849

3.3.2.4 DLPDLCR4710 Evaluation Module

The most expensive and best-performance evaluation module available from Texas Instruments is the DLPDLCR4710 Evaluation Module. It features the largest Pico™ display DMD chipset intended for mobile projections that Texas Instruments has to offer, as well as a high resolution display resolution, akin to the previously mentioned DLP3310.

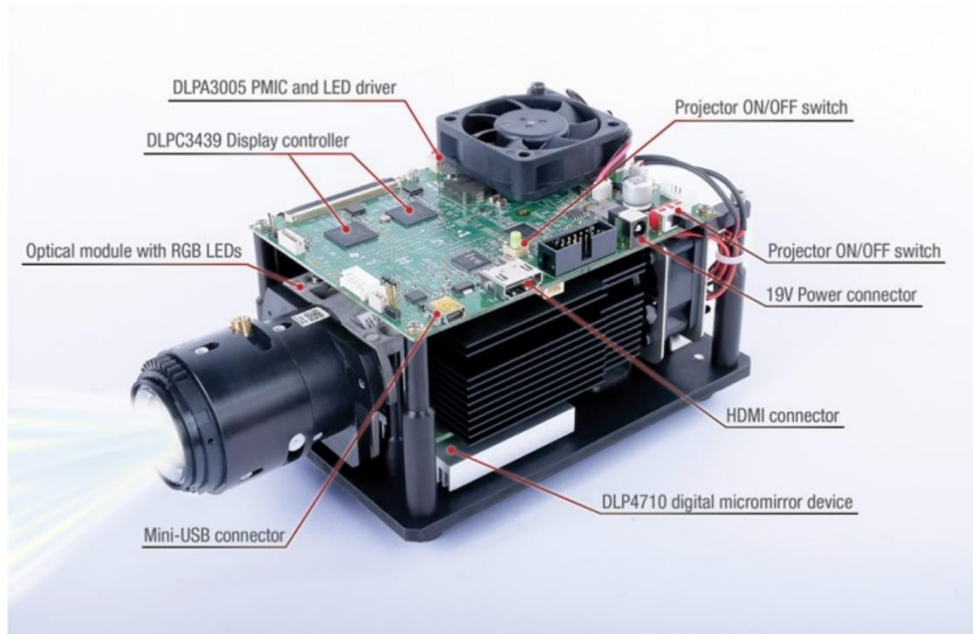

Figure 32 Texas instruments DLP4710 Evaluation Module

This module would be overkill for our project, as it requires way too much power to run, produces too much heat and takes up too much space. Although what initially attracted us to the device was its excellent resolution of 1080p and stellar illumination brightness of over 600 Lumens, the price alone is enough to turn a group of college students off from trying to use it.

Specs:

- Dimensions: 100x95x52mm
- Illumination brightness: 600 Lumens
- Power Supply: 19V DC, 4.74 A
- DMD Resolution: 1920x1080 (1080p)
- Throw Ratio: 1.39
- Cost: \$999

3.3.2.5. Conclusion

It becomes immediately apparent that we are not going to get all that we need from one optical module while staying within our price range. Our solution will be to purchase the cheapest optical engine we can get (the DLP2000 EVM) and increase the illumination brightness by replacing the illumination optics. The DLPCR2000 takes a DC power of 5V and 3A maximum, for a maximum power consumption of 15W, making it a medium-power consumption device. It is a small device simple enough to be taken apart and will be perfect for our personal modifications.

Features	DLCR2000	DLCR2010	DLCR3310	DLCR4710
DMD Resolution	640x360 (nHD)	854x480 (WVGA)	1920x1080 (1080p)	1920x1080 (1080p)
DMD Diagonal Length	0.2"	0.2"	0.33"	0.47"
Throw Ratio	1.6	1.3	1.2	1.34
Display Brightness	<100 Lumens	<100 Lumens	<300 Lumens	<550 Lumens
Dimensions	76x54mm	45x43mm		100x95x52mm
Drive power	5V DC, 3 A	5V DC, 3 A	19V DC, 3.42A	19V DC, 4.74 A
Cost	\$99	\$499	\$849	\$999

Table 3 - Optical Engine Comparison.

3.3.3. Microcontroller

A Microcontroller is a small microcomputer on a chip. It consists of a CPU, Random Access Memory (RAM), function registers, program Read-Only Memory (ROM), data ROM, between one to several input/output ports (I/O), and chip peripherals like Analog-to-Digital Converter (ADC), Digital-to-Analog Converter (DAC), Serial Universal Asynchronous Receiver/Transmitter (UART), one or several timers. They also consist of Serial Peripheral Interface/Inter integrated Circuit (SPI/I2C), USB port, ethernet port, and on chip oscillators. [63]

The hard drive of the microcontroller is considered the ROM memory, it is broken into two compartments. One part is for the permanent storage of data used for normal operation by the chip, and the other, for the storage of the program code. The Central Processing Unit or CPU, fetches and executes the instructions from the code. During program execution, the data space is used to temporarily store constant and variable values, also known as data RAM.

Microcontrollers are very powerful devices that execute a series of programmed task and it interacts with other devices. Lately, they have been inexpensive and very accessible.

3.3.3.1. Arduino Nano



Figure 33 - Arduino Nano

One popular microcontroller is the Arduino Nano, it is based on ATmega 328 or 168. This board is known for its very small size, something that can be very convenient for development. An advantage to using this board is that it doesn't require a heavy load of technical experience to be able to use it. [64] This board would be a strong candidate for this project because it is very simple to implement and it is flexible with different applications such as robotics, embedded systems, and automation. Also, it's breadboard friendly, uses the mini USB cable, and lacks a DC power pack. [65]

Nano Features:

- ATmega328P Microcontroller is from 8-bit AVR family
- Operating voltage is 5V
- Input voltage (Vin) is 7-12 V
- 22 I/O pins
- Analog i/p pins are 6 from A0 to A5
- Digital pins are 14
- Power consumption is 19 mA
- I/O pins DC Current is 40 mA
- Flash memory is 32 KB
- SRAM is 2 KB
- EEPROM is 1 KB
- CLK speed is 16 MHz
- Weight-7g
- Size of the printed circuit board is 18 X 45mm
- Supports three communications like SPI, IIC, & USART

3.3.3.2. Texas Instruments MSP430G2553

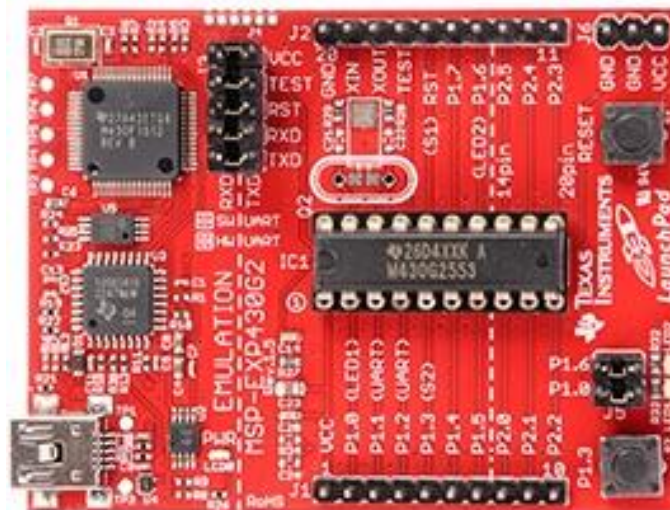

Figure 34 - MSP430G2553

The MSP430 MCU, offers variety of features, such as ultra-low power, integrated analog, digital peripherals for sensing and measurement applications. This MCU

was developed by Texas Instrument. Most of our group has used this MCU for almost all 3 courses such as Engineering Analysis and Computation, Junior Design, and Embedded Systems. This MCU is extremely familiar with the members of the group and has proven itself to be very reliable and easy to implement. In result, our group will be using this MCU for the development of the AUDIOVISIBLE. [65]

This controller can have up to 512KB of memory, and most importantly is low cost. All this group needs is some basic features to allow the device to work.

MSP430 features [66]:

- Low Supply-Voltage range: 1.8 V to 3.6 V
- Supports:
 - Universal Serial Communication Interface (USCI)
 - Ultra-Low Power Consumption
 - UART
 - Synchronous SPI
 - IrDA encoder and decoder
 - I2C
- 5 Power-Saving modes
- Ultra-Fast Wake-Up from Standby Mode in C less than 1 μ s
- Two 16-Bit Timer_A with three capture/compare registers
- 16-Bit RISC Architecture, 62.5-ns instruction cycle time
- 610-Bit 200-ksp/s Analog-to-Digital (A/D)
- Brownout detector
- Serial onboard programming

3.3.3.3. DISCOVERY STM32F3



Figure 35 - STM32F3 DISCOVERY

The STM32 is based on ARM Cortex -M4 and it has enough features to satisfy both beginners and experienced users. Some things that it includes is a debug tool, accelerometer, gyroscope, push buttons, LEDs, and USB connections. Unlike some other boards, this board has many LEDs that's accessible to programming and has two USB connection that could come in handy for additional ports. Also, the discovery can be powered by 3V or 5V power supply. If the AUDIOVISIBLE needed an MCU that supported a variety of features it would potentially be considered for the project. [67]

3.3.3.4. Conclusion

Below is a table comparing the specifications of each microcontroller. The MSP430 was a leading favorite due to its extensive documentation and affordable price, however, the main reason why it was chosen as the Microcontroller to use, is because every engineer in the group developing this project, had previous experience working with that particular MCU.

Feature	Arduino Nano	MSP430G2553	STM32F3
Operating Voltage	1.8 – 5.5V	1.8 – 3.6V	2.0 – 3.6V
Temperature Range	-40°C to 85°C	-40°C to 85°C	-40°C to 105°C
Max Clock Frequency	16 MHz	16 MHz	32MHz
Memory	32 KB Flash, 2KB SRAM, 1KB EEPROM	16 KB Flash, 0.5 SRAM	256 KB Flash, 48 KB RAM
Analog I/O	Input only	Both	Both
Digital I/O	Both	Both	Both
GPIO Pin Count	20	24	N/A
Bit Count	8-Bit	16-Bit	32-bit
Low Power	Yes	Yes	Yes
Power Consumption	Active Mode: 200µA @ 1MHz Off Mode: 0.1µA	Active Mode: 330µA @ 1MHz Off Mode: 0.1µA	
Board price	\$20.70	\$23.40	\$39.99

Table 4 - Microcontroller Comparison.

3.3.4. Audio Input - Bluetooth

In the early stages of the design, four different input methods were considered: microphone, WiFi, audio jack and Bluetooth. Out of this, after several iterations, the decision to only use the Bluetooth technology as the input method was final. This is a wireless technology standard designed for exchanging data between devices via short-wavelength radio waves. The range of the Bluetooth technology is a personal area network (PANs) which is perfect for an indoor visual experience. This is a very well know technology, almost inherent and obvious to all wireless audio devices. AUDIOVISIBLE is a device that from the input perspective, is not different to all other available wireless audio systems. Now the challenge is to choose from the various Bluetooth modules available in the market. Several modules were analyzed to determine the best fit for this device.

3.3.4.1. XY-P40W

Manufactured by WHDTS, the “WHDTS Stereo Bluetooth Power Amplifier Board Remote Control 5V 12V 24V 20W 30W 40W Infrared Receiver Module with Case”, contains the main components needed to connect a smartphone to a pair of speakers. This PCB contains many subassemblies besides the Bluetooth component; however, this is interesting to AUDIOVISIBLE from general electronic design and required cored components.

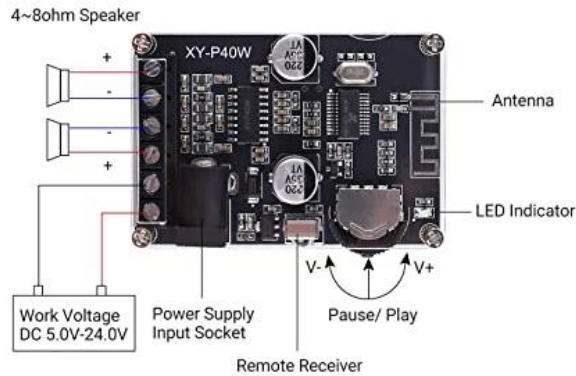

Figure 36 - WHDTS Stereo Bluetooth Power Amplifier Board

3.3.4.2. HC-05

The HC-05 Wireless Bluetooth Receiver RF Transceiver Module Serial Port Module, is a very popular Bluetooth module for hobbyists, because it can add two-way (full-duplex) wireless functionality to projects. This module can be used to communicate between two microcontrollers or communicate with any device with Bluetooth functionality like a Phone or Laptop. There are many android applications that are already available which makes this process a lot easier. The module communicates with the help of USART at 9600 baud rates, hence it is easy to interface with any microcontroller that supports USART. We can also configure the default values of the module by using the command mode. However, this module cannot transfer multimedia like photos or songs.

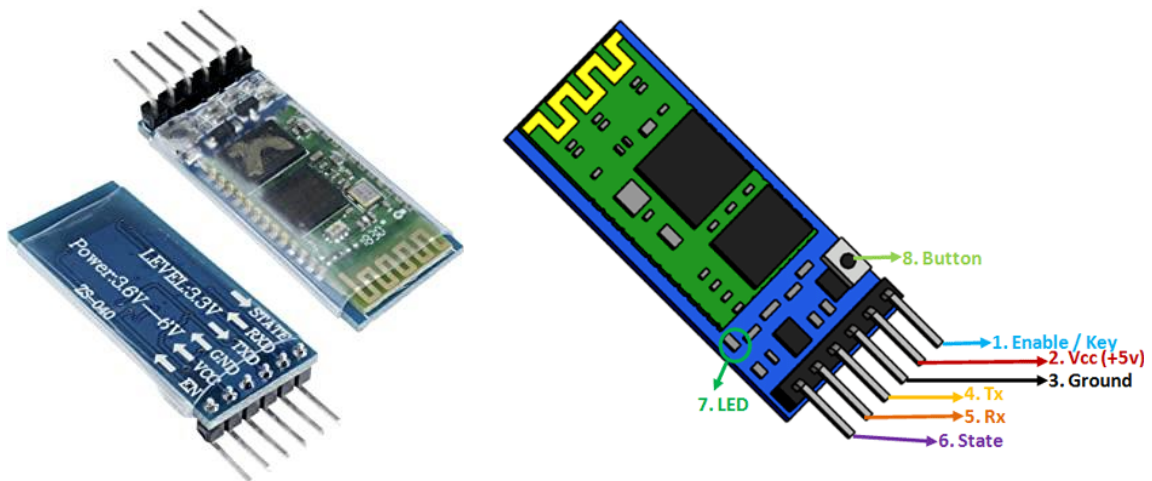

Figure 37 - Wireless BT HC-05 photo and pinout

3.3.4.3. TI CC2640

The CC2640 device is a low energy wireless MCU with 128kB flash, targeting Bluetooth applications. The device is a member of the CC26xx family of cost-effective, ultralow power, 2.4-GHz RF devices. Very low active RF and MCU

current and low-power mode current consumption provide excellent battery lifetime and allow for operation on small coin cell batteries and in energy-harvesting applications. The CC2640 device contains a 32-bit ARM Cortex-M3 processor that runs at 48 MHz as the main processor and a rich peripheral feature set that includes a unique ultralow power sensor controller. This sensor controller is ideal for interfacing external sensors and for collecting analog and digital data autonomously while the rest of the system is in sleep mode. Thus, the CC2640 device is ideal for a wide range of applications where long battery lifetime, small form factor, and ease of use is important. The Bluetooth Low Energy controller is embedded into ROM and runs partly on an ARM Cortex-M0 processor. This architecture improves overall system performance and power consumption and frees up flash memory for the application. [68]

Similar but not functionally equivalent is CC2640R2, which has more available flash memory & supports LE 2M PHY, LE Coded PHY (Long Range), multiple advertisement sets, and advertising extensions.

3.3.4.4. TI CC2640R2F

The CC2640R2F device is a 2.4 GHz wireless microcontroller (MCU) with 128kB Flash and 275kB ROM, supporting Bluetooth 5.1 Low Energy and Proprietary 2.4 GHz applications. The device is optimized for low-power wireless communication and applications where industrial performance is required. The highlighted features of this device include:

- Support for Bluetooth 5.1 features: LE Coded PHYs (Long Range), LE 2-Mbit PHY (High Speed), Advertising Extensions, Multiple Advertisement Sets, as well as backwards compatibility and support for key features from the Bluetooth 5.0 and earlier Low Energy specifications.
- Fully qualified Bluetooth 5.1 software protocol stack included with the SimpleLink CC2640R2F Software Development Kit (SDK) for developing applications on the powerful Arm Cortex-M3 processor.
- Longer battery life wireless applications with low standby current of 1.1 μ A with full RAM retention.
- Advanced sensing with a programmable, autonomous ultra-low power Sensor Controller CPU with fast wake-up capability. As an example, the sensor controller is capable of 1-Hz ADC sampling at 1 μ A system current.
- Dedicated software-controlled radio controller (Arm Cortex-M0) providing flexible low-power RF transceiver capability to support multiple physical layers and RF standards, such as real-time localization (RTLS) technologies.
- Excellent radio sensitivity and robustness (selectivity and blocking) performance for Bluetooth Low Energy (-103 dBm for 125-kbps LE Coded PHY).

The CC2640R2F device is part of the SimpleLink microcontroller (MCU) platform, which consists of Wi-Fi, Bluetooth Low Energy, Thread, ZigBee, Sub-1 GHz MCUs, and host MCUs that all share a common, easy-to-use development environment with a single core software development kit (SDK) and rich tool set.

A one-time integration of the SimpleLink platform enables you to add any combination of the portfolio’s devices into your design, allowing 100 percent code reuse when your design requirements change. [69]

3.3.4.5. Raspberry Pi Bluetooth

The Single Board Computer comes with an integrated Bluetooth 5.0 BLE (Bluetooth Low Energy). Almost every operating system that can be installed in this computer contains the firmware and drivers necessary for interaction.

3.3.4.6. Conclusion

After comparing and contrasting each Bluetooth module with one another, We have selected the integrated Bluetooth that comes with the Raspberry Pi 4. This simplifies the design and capitalizes on existing hardware.

Features	XY-P40W	HC-05	TI CC2640	TI CC2640R2F	Raspberry Pi 4
Bluetooth Standard	5.0	2.0	5.1	5.0/5.1	5.0
Voltage Supply	5 - 24V	+3.3V	1.8 - 3.8V	1.8 - 3.8 V	5.1 V
Communication distance	15 meters	10 meters	15 meters	1.5 kilometers	
Temperature Range	-40°C to 85°C	-20°C to 75°C	-40°C to 85°C	-40°C to 85°C	0°C to 50°C
Dimensions	55 x 38 x 14 (mm)	26.9 x 13 x 2.2 (mm)			3.94 x 2.76 x 1.18 (inches)
Price	\$4.99	\$8.99	\$5.15	\$5.08	\$60.78

Table 5 - Bluetooth Comparison.

3.3.5. Audio Output – Speakers

For the audio output, we will be using the Adafruit I2S 3W Stereo Speaker Bonnet for Raspberry Pi - Mini Kit for plugging in any speaker. Plugging in the speaker allows for a crisper, less-static based sound. With this add-on, it can configure with any Raspberry Pi version and is about the same size as the Raspberry Pi Zero model. We have included a mini speaker, but at any point, this can be taken out and a user can input their own speaker. It allows for any 4 to 8 ohm speaker with a max of 3 Watts [70].

Also, if a user prefers an individual output of their own, such as listening in headphones, the Raspberry Pi accommodates a headphone jack [71]. Unfortunately, there is no Bluetooth for headphones in this version of AUDIOVISIBLE, but in future versions, plans of more Bluetooth-friendly devices will be considered and implemented.

3.3.5.1. Tweeter 6 Ohm Speaker

The 6 Ohm tweeter from Skycraft Parts & Surplus will be included in the device. The speaker includes a crossover capacitor that can store the power coming into

the device and properly allow it to flow. For the small price of \$1.95, excluding tax, this small device can be able to release a large volume of sound.

3.3.5.2. Adafruit 4 Ohm 3-Watt Speaker

The 4 Ohm, 3-Watt speaker from Adafruit has a cone-like shape and four mounting tabs. For the same price as the Skycraft 6 Ohm Tweeter, \$1.95, it does not have the same features as the tweeter and is not as loud. Shipping would also increase the price of the device.

3.3.5.3. Pirate Audio

Pirate Audio is a I2C mini speaker with an LCD screen made for the Raspberry Pi. The pros about the speaker is that it is 1-Watt and 8-Ohms as well as having the LCD touch screen attached. It would make for a more enhanced and innovative user experience and it includes an audio amplifier. The software is simple to install using a Linux command terminal and git. The cons are that it is \$20+ and shipping would cost extra money, thus increasing the price of our overall product.

3.3.5.4. Adafruit Mini Metal Speaker 8 Ohm 0.5 Watt

The Mini Metal Speaker is also available on Adafruit and can handle 8 Ohms 0.5 Watts. The pros are that it is cheap, \$1.95, and for such a small device can output a medium sound. It works easily with the audio amplifier bonnet bought. The cons are shipping that make it pricier and it is for small audio projects.

3.3.5.5. Conclusion

The Skycraft audio speaker was chosen due to price and feasibility of picking up. It includes 4 pins and is in the right range of impedance. It is compact and can still output enough audio for a gathering. The tweeter can deliver high frequencies and can have higher quality audio than the average speaker. It also includes the capacitor, which can assist with voltage and current flow [72].

Feature	Skycraft 6 Ohm	Adafruit 4 Ohm	Pirate Audio	Adafruit 8 Ohm
Price	\$1.95	\$1.95 + shipping	\$20.31 + shipping	\$1.95 + shipping
Impedance	6 Ohms	4 Ohms	8 Ohms	8 Ohms
Power	Unknown	3 Watts	1 Watt	0.5 Watts

Table 6 - Speaker Comparison.

3.3.6. Audio Processing – Host Processor

This is perhaps, the cornerstone of this project. Every single subsystem, every single line of code, every single design consideration, as been made in service of this section. Audio processing is the heart of AUDIOVISIBLE. This section is extremely important because the only way to serve an underserve audience, and serve it well, is by delivering a visual experience that would allow some sort of fidelity to the original audio experience. For this, a subassembly with an integrated Graphical Processing Unit (GPU), and a Central Processing Unit (CPU) might be the only way to accomplish such a feat.

Before processing any audio, it would be important to define a baseline, or default visualization that would fill the gaps when the audio processing is taking too long, and the audio continues to play. The decoupling of the audio and visual outputs would mean that a failure in processing one would not affect the other but would bring challenges in synching both for a coherent production.

3.3.6.1. Raspberry Pi

Raspberry Pi 4 Model B is the latest product in the popular Raspberry Pi range of computers. It offers ground-breaking increases in processor speed, multimedia performance, memory, and connectivity compared to the prior-generation Raspberry Pi 3 Model B+, while retaining backwards compatibility and similar power consumption. For the end user, Raspberry Pi 4 Model B provides desktop performance comparable to entry-level x86 PC systems.

This product's key features include a high-performance 64-bit quad-core processor, dual-display support at resolutions up to 4K via a pair of micro-HDMI ports, hardware video decode at up to 4Kp60, up to 8GB of RAM, dual-band 2.4/5.0 GHz wireless LAN, Bluetooth 5.0, Gigabit Ethernet, USB 3.0, and PoE capability (via a separate PoE HAT add-on).

The dual-band wireless LAN and Bluetooth have modular compliance certification, allowing the board to be designed into end products with significantly reduced compliance testing, improving both cost and time to market.



Figure 38 - Raspberry Pi 4 Model B

There are large amounts of tutorials and projects available online that might make the use of the Raspberry Pi very appealing. However, the main reason it is being considered for, is due to the integrated Bluetooth module, HDMI outputs and capability to run high-level programming languages like Python.

Looking at the hardware of the Raspberry Pi 4 seems very appealing, but one cannot stop there, and it is as important to consider the software stack as well. In general, a Raspberry Pi 4 supports a wide range of different Operating Systems, and its manufacturers offer a very simple software tool to prepare the SD card where the OS would be installed, making the whole process even easier. Now, in order to properly select the OS, it is important to consider the main reasons to use this single-board computer: Bluetooth input, Python support, and HDMI output.

Raspberry OS (previously Raspbian) is the most popular distro used in Raspberry Pi boards as of July 2020, is an actively maintained and feature-rich OS, that comes with lots of preinstalled packages and all necessary drivers to get up and running fast and easy.

Hardware

- Quad core 64-bit ARM-Cortex A72 running at 1.5GHz
- 1, 2 and 4 Gigabyte LPDDR4 RAM options
- H.265 (HEVC) hardware decode (up to 4Kp60)
- H.264 hardware decodes (up to 1080p60)
- VideoCore VI 3D Graphics
- Supports dual HDMI display output up to 4Kp60

Interfaces

- 802.11 b/g/n/ac Wireless LAN
- Bluetooth 5.0 with BLE
- 1x SD Card
- 2x micro-HDMI ports supporting dual displays up to 4Kp60 resolution
- 2x USB2 ports
- 2x USB3 ports
- 1x Gigabit Ethernet port (supports PoE with add-on PoE HAT)
- 1x Raspberry Pi camera port (2-lane MIPI CSI)
- 1x Raspberry Pi display port (2-lane MIPI DSI)
- 28x user GPIO supporting various interface options:
 - Up to 6x UART
 - Up to 6x I2C
 - Up to 5x SPI
 - 1x SDIO interface
 - 1x DPI (Parallel RGB Display)
 - 1x PCM
 - Up to 2x PWM channels
 - Up to 3x GPCLK outputs

GPIO Interface

The Pi4B makes 28 BCM2711 GPIOs available via a standard Raspberry Pi 40-pin header. This header is backwards compatible with all previous Raspberry Pi boards with a 40-way header.

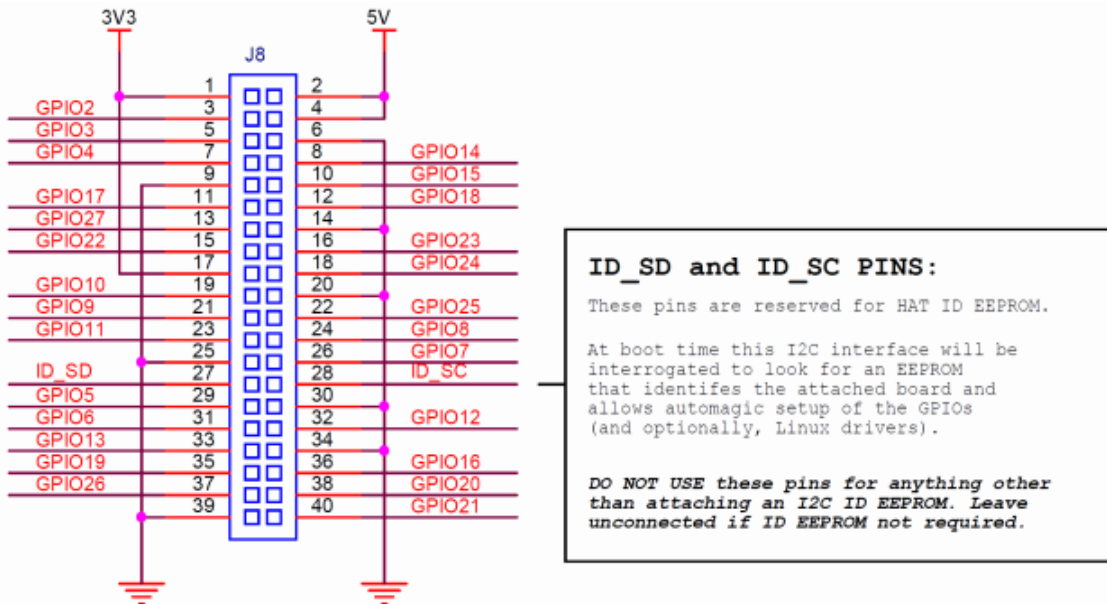

Figure 39 - GPIO Connector Pinout for Raspberry Pi 4

Software

- ARMv8 Instruction Set
- Mature Linux software stack
- Actively developed and maintained
 - Recent Linux kernel support
 - Many drivers up streamed
 - Stable and well supported userland
 - Availability of GPU functions using standard APIs

3.3.6.2. Jetson Nano

The Jetson Nano module is a small AI computer that has the performance and power efficiency needed to run modern AI workloads, multiple neural networks in parallel and process data from several high-resolution sensors simultaneously. This makes it the perfect entry-level option to add advanced AI to embedded products. Jetson Nano brings AI to a world of new embedded and IOT applications, including entry-level network video recorders (NVRs), home robots, and intelligent gateways with full analytics capabilities.



Figure 40 - NVIDIA Jetson Nano

NVIDIA Jetson Nano Developer Kit is a small, powerful computer that lets you run multiple neural networks in parallel for applications like image classification, object detection, segmentation, and speech processing. All in an easy-to-use platform that runs in as little as 5 watts.

The NVIDIA website warns that the Jetson developer kits are not for production use. The developer kit is used to develop and test software in a pre-production environment. However, they are perfect from a prototype and final presentation perspective.

The use of the NVIDIA Jetson Nano could potentially allow AUDIOVISIBLE to run machine learning algorithms to the audio input, almost in real time. The risk would be the possibility of interrupting the audio or video or keeping them in synch.

Maxwell GPU[®]

128-core GPU | End-to-end lossless compression | Tile Caching | OpenGL[®] 4.6 | OpenGL ES 3.2 | Vulkan™ 1.1 | CUDA[®] | OpenGL ES Shader Performance (up to): 512 GFLOPS (FP16) | Maximum Operating Frequency: 921MHz

CPU

ARM[®] Cortex[®]-A57 MPCore (Quad-Core) Processor with NEON Technology | L1 Cache: 48KB L1 instruction cache (I-cache) per core; 32KB L1 data cache (D-cache) per core | L2 Unified Cache: 2MB | Maximum Operating Frequency: 1.43GHz

Audio

Industry standard High Definition Audio (HDA) controller provides a multichannel audio path to the HDMI interface.

Memory

Dual Channel | System MMU | Memory Type: 4ch x 16-bit LPDDR4 | Maximum Memory Bus Frequency: 1600MHz | Peak Bandwidth: 25.6 GB/s | Memory Capacity: 4GB

Storage

eMMC 5.1 Flash Storage | Bus Width: 8-bit | Maximum Bus Frequency: 200MHz (HS400) | Storage Capacity: 16GB

Boot Sources

eMMC and USB (recovery mode)

Networking

10/100/1000 BASE-T Ethernet | Media Access Controller (MAC)

Imaging

Dedicated RAW to YUV processing engines process up to 1400Mpix/s (up to 24MP sensor) | MIPI CSI 2.0 up to 1.5Gbps (per lane) | Support for x4 and x2 configurations (up to four active streams).

Operating Requirements

Temperature Range (T_j): -25 – 97C° | Module Power: 5 – 10W | Power Input: 5.0V

Display Controller

Two independent display controllers support DSI, HDMI, DP, eDP: MIPI-DSI (1.5Gbps/lane): Single x2 lane | Maximum Resolution: 1920x960 at 60Hz (up to 24bpp) | HDMI 2.0a/b (up to 6Gbps) | DP 1.2a (HBR2 5.4 Gbps) | eDP 1.4 (HBR2 5.4Gbps) | Maximum Resolution (DP/eDP/HDMI): 3840 x 2160 at 60Hz (up to 24bpp)

Clocks

System clock: 38.4MHz | Sleep clock: 32.768kHz | Dynamic clock scaling and clock source selection

Multi-Stream HD Video and JPEG

Video Decode

H.265 (Main, Main 10): 2160p 60fps | 1080p 240fps
H.264 (BP/MP/HP/Stereo SEI half-res): 2160p 60fps | 1080p 240fps
H.264 (MVC Stereo per view): 2160p 30fps | 1080p 120fps
VP9 (Profile 0, 8-bit): 2160p 60fps | 1080p 240fps
VP8: 2160p 60fps | 1080p 240fps
VC-1 (Simple, Main, Advanced): 1080p 120fps | 1080i 240fps
MPEG-2 (Main): 2160p 60fps | 1080p 240fps | 1080i 240fps

Video Encode

H.265: 2160p 30fps | 1080p 120fps
H.264 (BP/MP/HP): 2160p 30fps | 1080p 120fps
H.264 (MVC Stereo per view): 1440p 30fps | 1080p 60fps
VP8: 2160p 30fps | 1080p 120fps

JPEG (Decode and Encode): 600 MP/s

Peripheral Interfaces

xHCI host controller with integrated PHY: 1 x USB 3.0, 3 x USB 2.0 | USB 3.0 device controller with integrated PHY | EHCI controller with embedded hub for USB 2.0 | 4-lane PCIe: one x1/2/4 controller | single SD/MMC controller (supporting SDIO 4.0, SD HOST 4.0) | 3 x UART | 2 x SPI | 4 x I2C | 2 x I2S: support I2S, RJM, LJM, PCM, TDM (multi-slot mode) | GPIOs

Mechanical

Module Size: 69.6 mm x 45 mm | PCB: 8L HDI | Connector: 260 pin SO-DIMM

Figure 41 - NVIDIA Jetson Nano Data Sheet.

3.3.6.3. BeagleBone Black

The BeagleBone Black is the newest member of the BeagleBoard family. It is a lower-cost, high-expansion focused BeagleBoard using a low cost Sitara XAM3359AZCZ100 Cortex A8 ARM processor from Texas Instruments. It is similar to the Beagle bone, but with some features removed and some features added.

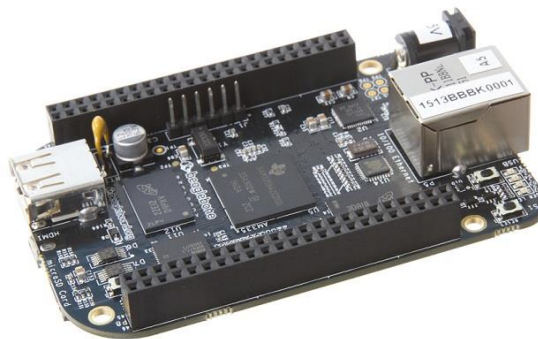

Figure 42 - BeagleBone Black (BBB)

The BeagleBone Black is designed to address the Open Source Community, early adopters, and anyone interested in a low-cost ARM Cortex-A8 based processor. The fact that uses TI components, make this a desirable option. It is equipped with a minimum set of features to allow the user to experience the power of the processor. It allows for the use of add-on boards called capes, to add many different combinations of features. A user may also develop their own board or add their own circuitry.

Capes are daughter-board add-on products for BeagleBone-family products. Each extends the functionality of the BeagleBone for new interesting capabilities. Hundreds of cape designs are available in the community and now there is also a line of BeagleBoard.org capes readily available from numerous world-wide distributors.

	Feature	
Processor	Sitara AM3358BZCZ100 1GHz, 2000 MIPS	
Graphics Engine	SGX530 3D, 20M Polygons/S	
SDRAM Memory	512MB DDR3L 800MHZ	
Onboard Flash	4GB, 8bit Embedded MMC	
PMIC	TPS65217C PMIC regulator and one additional LDO.	
Debug Support	Optional Onboard 20-pin CTI JTAG, Serial Header	
Power Source	miniUSB USB or DC Jack	5VDC External Via Expansion Header
PCB	3.4" x 2.1"	6 layers
Indicators	1-Power, 2-Ethernet, 4-User Controllable LEDs	
HS USB 2.0 Client Port	Access to USB0, Client mode via miniUSB	
HS USB 2.0 Host Port	Access to USB1, Type A Socket, 500mA LS/FS/HS	
Serial Port	UART0 access via 6 pin 3.3V TTL Header. Header is populated	
Ethernet	10/100, RJ45	
SD/MMC Connector	microSD , 3.3V	
User Input	Reset Button Boot Button Power Button	
Video Out	16b HDMI, 1280x1024 (MAX) 1024x768,1280x720,1440x900 ,1920x1080@24Hz w/EDID Support	
Audio	Via HDMI Interface, Stereo	
Expansion Connectors	Power 5V, 3.3V , VDD_ADC(1.8V) 3.3V I/O on all signals McASP0, SPI1, I2C, GPIO(69 max), LCD, GPMC, MMC1, MMC2, 7 AIN(1.8V MAX), 4 Timers, 4 Serial Ports, CAN0, EHRPWM(0,2),XDMA Interrupt, Power button, Expansion Board ID (Up to 4 can be stacked)	
Weight	1.4 oz (39.68 grams)	
Power	Refer to Section 6.1.7	

Figure 43 - Key features of the BeagleBone Black.

The BBONE-BLACK-4G features TI's Sitara™ AM3358AZCZ100 microprocessor, which is based on ARM Cortex-A8 core with enhanced image, graphics processing, peripherals and industrial interface options such as EtherCAT and PROFIBUS. The board is equipped with 256Mb x16 DDR3L 4Gb (512MB) SDRAM, 32KB EEPROM, and 4GB embedded MMC (eMMC) Flash as the default boot source. The board is also populated with a single microSD connector to act

as a secondary boot source for the board and, if selected as such, can be the primary boot source. The BeagleBone Black supports four boot modes, including eMMC boot, microSD boot, serial boot, and USB boot. A switch is provided to allow switching between the modes.

In contrast to the original BeagleBone, the BBONE-BLACK-4G has an onboard HDMI interface to connect directly to TVs and monitors. Other features include a 10/100 Ethernet interface, a serial debug port, a PC USB interface, an USB 2.0 host port, a reset button, a power button, and five indicating blue LEDs. The BeagleBone Black has the ability to accept up to four expansion boards or capes that can be stacked onto the expansion headers. The majority of capes designed for the original BeagleBone will work on the BeagleBone Black.

3.3.6.4. Conclusion

Features	Raspberry Pi 4 B+	NVIDIA Jetson Nano	BeagleBone
CPU	Quad-core ARM Cortex-A72 64-bit @ 1.5 Ghz	Quad-Core ARM Cortex-A57 64-bit @ 1.42 Ghz	Sitara AM3358AZCZ100 1GHz 2000 MIPS
GPU	Broadcom VideoCore VI (32-bit)	NVIDIA Maxwell w/ 128 CUDA cores @ 921 Mhz	SGX530 3D, 20M Polygon/S
Memory	4 GB LPDDR4	4 GB LPDDR4	512 MB DDR3L
Networking	Gigabit Ethernet / Wifi 802.11ac	Gigabit Ethernet / M.2 Key E (for Wifi support)	Gigabit Ethernet
Display	2x micro-HDMI (up to 4Kp60)	HDMI 2.0 and eDP 1.4	HDMI 1280x1024
USB	2x USB 3.0, 2x USB 2.0	4x USB 3.0, USB 2.0 Micro-B	1x USB
Storage	Micro-SD	Micro-SD	4 GB + Micro-SD
Price	\$60	\$107	\$60

Table 7 - Single Board Computer Comparison.

After reviewing both single board computers, the Raspberry Pi 4 seems to be the option due to two reasons: price and documentation.

3.4 Hardware Design Details

The good part about using a Single Board Computer, like the Raspberry Pi 4, is that it allows the engineers to focus on the other main hardware assemblies, namely the Optics, Power, and Audio assemblies. This section covers the different considerations and variations available for each assembly.

3.4.1. Optics Assembly

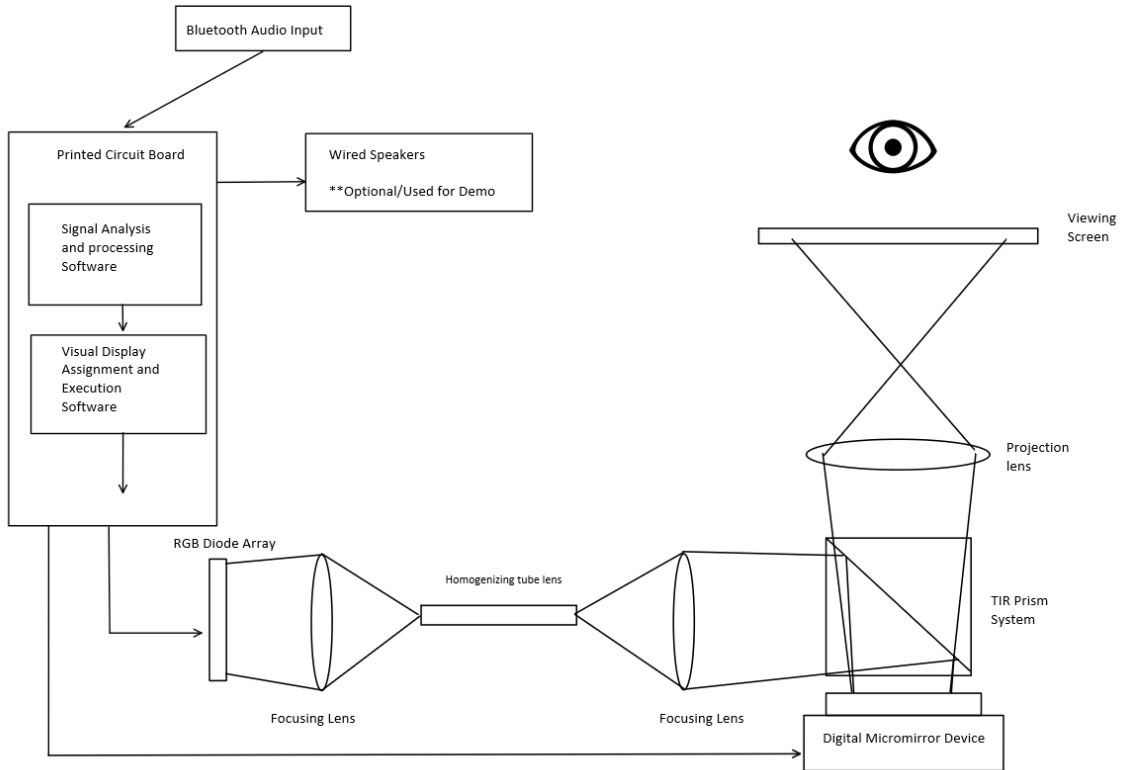

Figure 44 - Preliminary rough sketch/rendering of the expected optical components needed to achieve a successful prototype

AUDIOVISIBLE’s optical setup is inspired entirely by DLP projection technology. Our device will feature a semiconductor diode array, collimated and homogenized. This light will illuminate a digital micromirror device, which will be programmed to produce a two-dimensional image, which is projected through a prism system and onto a viewing screen.

As shown in Figure __ above, light from the diode array will be focused using a condenser lens and TIR prism system onto the DMD. Light exiting the prism setup is finally focused through the projection lens onto the viewing screen.

3.4.2. Audio Assembly

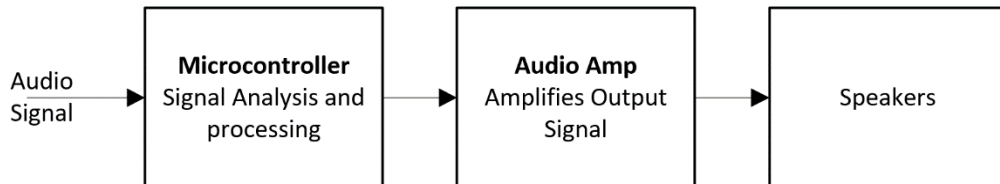

Figure 45 - Audio Output Block Diagram.

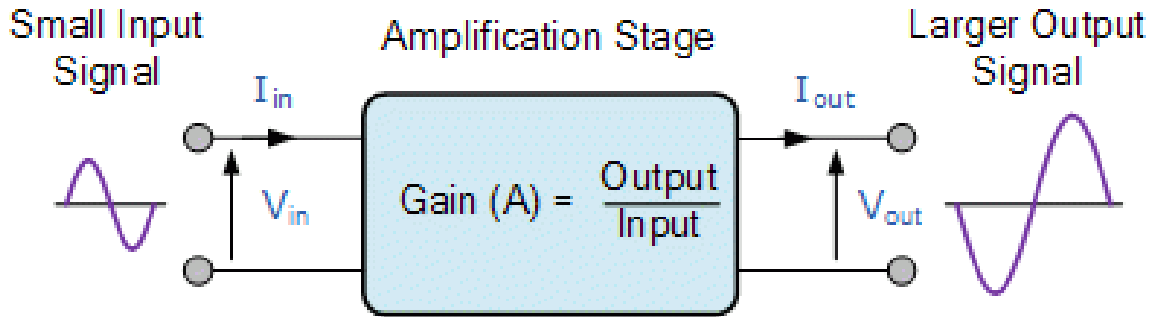

Figure 46: Diagram as to how the signal is interpreted through the speaker

AUDIOVISIBLE's technology includes an audio amplifier and a 4 Ohm 3 Watt speaker. The device will allow for a medium party of people to have a loud volume of sound, controlled by their smartphone device. The audio amplifier will increase the amplitude of the sound wave and allowing it to play through the speaker. The audio amplifier is a bonnet that connects on top of the Raspberry Pi and has a pin for the speaker. With a simple interface connection, it allows for easy plug in of the amplifier and the speaker.

3.4.3. Power Assembly

There will be two separate power supplies included in this project. The raspberry pi has its pre-assembled USB-C power supply, with the current specifications of:

- 5.1V/3.0A DC output
- 96-264Vac input range
- Short circuit, overcurrent and over temperature protection
- 1.5m 18 AWG captive cable with USB-C output connector
- 15.3W of maximum power

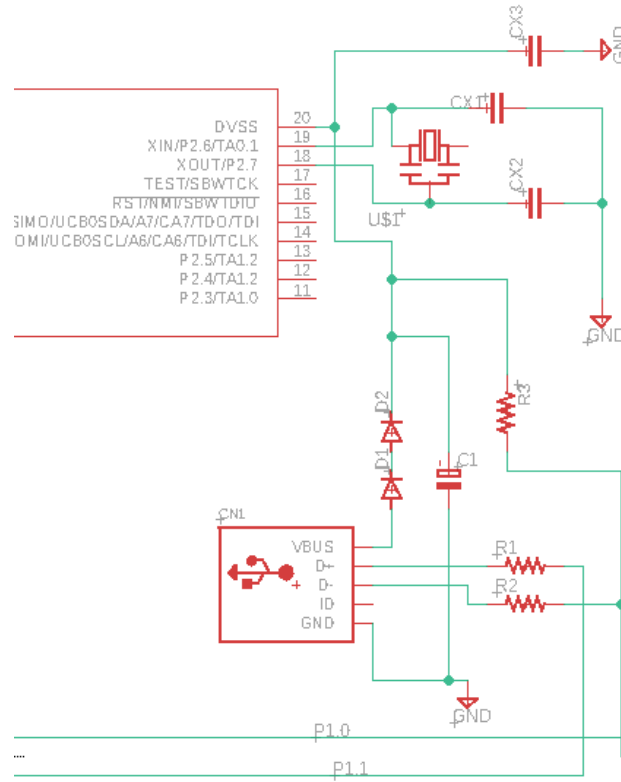

Figure 39: USB Hub Schematic

The PCB will be USB powered, with a male A-male to mini-B USB 2.0 cable. A female USB mini b port will be soldered to the board. The MSP430 requires an input voltage of 3.3V. The output voltage of the USB cable will be approximately 5V. So, the voltage regulator will be added to the circuit to ensure that the DC-DC conversion is stepped down from 5v to 3.3V.

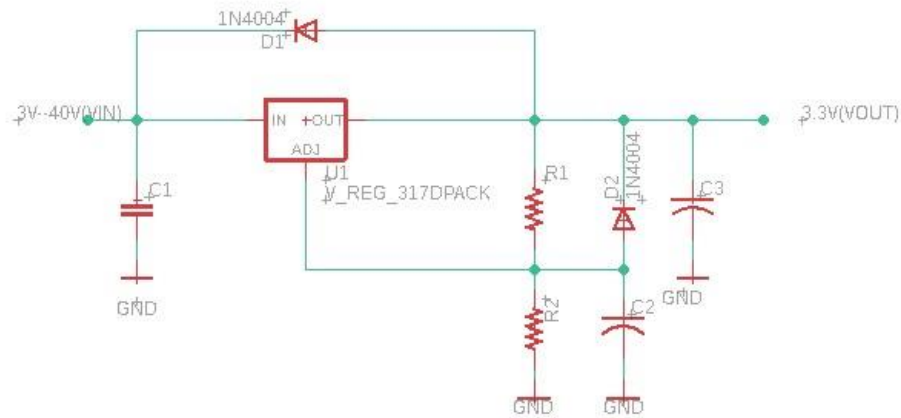

Figure 40: Voltage Regulator

For the voltage regulation to be successful, we used a LM317 from Texas Instrument. The LM317 device is an adjustable three-terminal positive-voltage regulator capable of supplying more than 1.5 A over an output-voltage range of 1.25 V to 37 V. To set the output voltage, two external resistors are required. [73] Some useful features that are included into the electrical characteristics:

- Line regulation of 0.01%
- Load regulation of 0.01%
- Current limiting
- Thermal overload protection
- Safe operating area protection

Components	Description
R1 & R2	Set output voltage
C1	Provides sufficient bypassing
C2	Improves ripple rejection
D1 & D2	Provides a low-impedance discharge path to prevent the capacitor from discharging into the output of the regulator.
C3	Improves transient response

Table 8 - Power Assembly Components.

3.5. Software Design Details

The available software landscape for this product, depends heavily on the final components available in the current pandemic-stricken market. The good news is that software has never been better, from the implementation of languages in platforms never thought of, to the easily accessible resources and support. This section will try to compare the different options available to fulfill our core requirements, as well as our stretch goals.

3.5.1. Software Architecture

The software Architecture is dependent on the specific hardware implementation of the AUDIOVISBLE device. According to the conducted research, there will be a couple of distinct software layers that might be required to accomplish the project objectives, however, depending on the success in the development of core and advanced features, it is possible that extended architecture might be required to complete the stretch goals.

3.5.1.1. Embedded System

For all the MCUs, some programming might be necessary. There are potentially three sections that will require some sort of programming: the DMD MCU, the Audio output MCU and the Power MCU. Out of those possibilities, the only one that is necessary is the DMD MCU, the other assemblies can function without an MCU. For the DMD MCU, there is really a single C file that needs to be completed in CodeBlocks or Visual Studio Code. The programming paradigm is Structured Programming, and the whole purpose for this program, is controlling the Digital Micromirror Device.

3.5.1.2. Audio Processing Application

Using a Single Board Computer to capture the input, process the audio, and emit an output, allows for two different software architectures: desktop and web. The main programming will continue to be the same, however, the rendering of the visualization uses different technologies. In general lines, the single board computer performs the following steps every time it turns on:

1. Opens the application, ideally in full screen.
2. Waits for a connection.
3. Displays a simple image while it waits for a connection. Most likely this image will show some sort of instructions.
4. Once a connection is successful, the device would start processing the input stream and generating a visual stream from it.
5. The visual stream would be outputted to the screen.
6. The audio stream would be outputted to the speakers.

3.5.1.2.1. Desktop/Local Architecture

The architecture of a local application is quite common, and its complexities are related to the use of drawing libraries. The main components would be:

1. Startup program: this would make sure the application opens, ideally in full screen, and that it would display an image until connection is established.
2. Bluetooth Processing: a set of methods that would be capturing and buffering the Bluetooth input, to periodically send it to another component for processing.
3. Audio Processing: Upon getting the stream from the Bluetooth processing, the stream would be cleaned, and sent for video processing.
4. Video Processing: depending on the type of video visualization, the process would use a different a different programming library.

3.5.1.2.2. Web Architecture

The architecture of a web application is a different from a local application, and its complexities are related to passing the data to the HTML file. The reason behind this consideration, is that there are useful technologies to display visualizations based on the power of JavaScript, that could be incredibly useful. The main components would be:

1. Startup program: this would make sure the web browser opens, ideally in full screen, and that it would display an image until connection is established.
2. API:
 - a. Bluetooth Processing: a set of methods that would be capturing and buffering the Bluetooth input, to periodically send it to another component for processing.
 - b. Audio Processing: Upon getting the stream from the Bluetooth processing, the stream would be cleaned, and sent for video processing.
3. UI:

- a. Video Processing: depending on the type of video visualization, the process would use a different a different programming library.

3.5.1.3. Conclusion

After reviewing the intrinsic advantages of using one architecture or another, AUDIOVISIBLE would use them all, depending on how far the engineering team is able to push the visualization engine. More specifically, the embedded architecture needed for the MCUs that would control the video input from the single board computer, will be very simple and probably written in C. Then, for the actual audio processing, the local application would be the choice for the first iteration, leaving the Web application for a second iteration, most likely.

Features	Embedded	Local	Web
Language	C	Python	Python + JS + HTML
Platform	MCU	Single Board Computer	Single Board Computer
Purpose	DMD Control	Audio Processing	Audio Processing

Table 9 - Software Architecture Comparison

3.5.2. Programming Languages

Programming languages might vary depending on the subsystem requirements, and the subsystems will vary depending on the implementation of specific stretch goals. Therefore, the programming languages used might vary with fluidity, depending on the specific challenge being faced at the specific iteration.

3.5.2.1. C

General-purpose, procedural programming language that supports structured programming, lexical variable scope, and recursion, with a static type system. By design, C provides constructs that map efficiently to typical machine instructions, one for this reason, it is the ideal candidate for controlling the MCUs. This computer language has found lasting use in applications previously coded in assembly language. Such applications include operating systems and various application software for computers architectures that range from supercomputers to PLCs and embedded systems.

3.5.2.2. C++

Object-oriented programming (OOP) language with what many other programming language libraries are built with, it is great with low-level interactions. One of the disadvantages for the engineering team, is the lack of experience with this language, its learning curve makes it unappealing when compared with other OOP languages like Python or Java. C++ can perform visualization and AI functionalities. Garbage collection and memory management are not built in, forcing the developer to develop this functionality in program.

3.5.2.3. C#

The Microsoft official OOP language, C# reads “see sharp”, based on Java and C, with Visual Studio as its IDE environment, works perfectly on other operating systems besides Windows. However, C# was originally designed to be the de facto enterprise level programming language, and it is not as well suited for embedded

applications. Since its inception, it has depended on the .NET Framework, which is a large collection of libraries with almost all the necessary functionalities to develop large scale applications, and in recent years, .NET Core was released as an open source framework to work on other platforms and be much lighter.

3.5.2.4. Java

Java is a general-purpose programming language that is class-based, object-oriented, and designed to have as few implementation dependencies as possible. It is intended to let application developers write once, run anywhere (WORA), meaning that compiled Java code can run on all platforms that support Java without the need for recompilation. Java applications are typically compiled to bytecode that can run on any Java virtual machine (JVM) regardless of the underlying computer architecture. The syntax of Java is similar to that of C and C++, but it has fewer low-level facilities than either of them. Many universities and bootcamps require students to take advanced Java courses as part of the basic curriculum because its extensive written works, thousands of applications, multi-platform support, and popularity in the industry.

3.5.2.5. Python

Object-oriented programming language geared more towards open-source libraries for visualization, music, artificial intelligence, photonics calculations, and scripting, with massive amounts of community support, documentation and tutorials. Python, unlike most other programming languages, can be condensed and easily read by those without a technical background. In its initial stages, it was known as ABC and developed in Amsterdam, the Netherlands in the 1980s. By the end of the decade, Guido van Rossum was at Centrum Wiskunde & Informatica developing an operating system, virtual machine, and new syntax which all eventually came to be the prehistoric stages of the Python language. It was only first open to the public in 1991 and currently, as of 2020, is on version 3.

Since the Python interpreter, unlike other languages, performs automatic memory management, tactics have to be performed in order to salvage run time and memory. Libraries like Numpy and StringBuilder have efficient methods and calls that can be input into the code. Heapy and objgraph can be used for detecting memory leaks and where most of the memory is being taken up. By adding *timed_decorator* to a method or function, it allows for meticulous inspection of how much time is being utilized in each aspect of the code. Pylint will be implemented to ensure formal standards of the language were present. Microsoft Teams and Sphinx will manage our documentation to reduce extraneous stress. As a team, there will be ensured and repeated testing of every aspect of the code to grant full user satisfaction of the product.

Python is very modern in that it allows for open-source libraries to be implemented into the code to perform many operations. With a virtual environment, temporary download of these libraries can take up less space on a computer. According to Python.org, "Python programs are typically 3-5 times shorter than equivalent Java programs". Java, also another object-oriented programming language, typically requires more elaborate code for the same generalized purpose and due to time

constraints, we need efficiency in time. Although Python is not as efficient as Java, due to interpreting code at run time, it allows for more versatility and all members of the group are familiar with the language.

As for the programming side of the photonics we are implementing, there will be some graphs organized to measure if our DMDs and projector-style lasers are properly operating. By utilizing Matplotlib and some trigonometrical functions, we can check if the signals are working accordingly in a simulation, based off our predictions. The goal is to measure the time-domain, the frequency linear domain, and the frequency domain eigensolver. The time domain is solved using Maxwell's Equation for $E(x,t)$ and $H(x,t)$. The frequency domain linear solves for steady-state harmonics with $E(x)$ and $H(x)$. The frequency domain eigensolver is for calculating source-free eigenfields [74].

3.5.2.6. Conclusion

After a lengthy analysis of pros and cons, the most appropriate language for the neural networks is Python. Although it has a slower speed upon compiling, it is the most recognizable and easiest language to learn. It has methods that allow for short scripts and flexibility with libraries. Some libraries are meant only for Python and there are tons of resources online that showcase steps on how to make a neural network or how to display images.

Features	Python	C++	Java	C#	C
Performance	Fast	Fast	Medium	Medium	Super-fast
Difficulty	Easy	Hard	Medium	Medium	Hard
Length	Short	Long	Long	Medium	Longest
Scope	High-Level	Low-Level	High-Level	High-Level	Low-Level

Table 10 – Audio Processing Programming Language Comparison.

However, for the MCUs, different aspects need to be considered, and especially performance. The microcontroller will be giving instructions to the micromirror device, and slow performance would translate into a bad experience.

Features	C	C++	Java	C#	Python
Performance	Super-fast	Fast	Medium	Medium	Slow
Difficulty	Medium	Hard	Medium	Medium	Hard
Length	Medium	Long	Long	Medium	Short
Scope	Low-Level	Low-Level	High-Level	High-Level	High-Level

Table 11 - Microcontroller Programming Language Comparison

3.5.3. Artificial Intelligence and Neural Networking

Artificial Intelligence (AI) is the operations of autonomy and continuous learning within a system. In a program using AI, there is the idea of a system of neural networks, or interconnected layers of data with an input, hidden layer, and an output. With each connection, the system can “learn” from the more data that is inserted. The delta rule, commonly seen in backpropagational neural networks, is a way for the network to learn with epochs, or rounds, of data that is compiled to the input [75] [76].

3.5.3.1. Tensorflow

A common library that is seen in Python programming of neural networks is Tensorflow. This library allows for the creation and training of machine learning models. With support from large companies, such as Google and Twitter, it is a reliable tool for the creation of AUDIOVISIBLE's models and knowledge [77]. The library is open source, meaning new features over time from many developers have been included and created, allowing for more accuracy and advancement of the tool [78].

An example usage of Tensorflow as shown on the Tensorflow website would be [79]:

```
1 import tensorflow as tf
2
3 mnist = tf.keras.datasets.mnist
4
5 (x_train, y_train), (x_test, y_test) = mnist.load_data()
6 x_train, x_test = x_train / 255.0, x_test / 255.0
7
8 model = tf.keras.models.Sequential([
9     tf.keras.layers.Flatten(input_shape=(28, 28)),
10    tf.keras.layers.Dense(128, activation='relu'),
11    tf.keras.layers.Dropout(0.2),
12    tf.keras.layers.Dense(10)
13 ])
14
15 predictions = model(x_train[:1]).numpy()
16 predictions
17
18 tf.nn.softmax(predictions).numpy()
19
20 loss_fn = tf.keras.losses.SparseCategoricalCrossentropy(from_logits=True)
21
22 loss_fn(y_train[:1], predictions).numpy()
23
24 model.compile(optimizer='adam',
25              loss=loss_fn,
26              metrics=['accuracy'])
27
28 model.fit(x_train, y_train, epochs=5)
29
```

Figure 47 - Tensorflow usage example

This code snippet creates the training model and epochs. With a minor knowledge in statistics, it can facilitate the process and a user can easily understand what is being performed. The code begins with loading a MNIST dataset and placing model layers on top of one another. A vector is created for the predictions. The loss is then calculated to be able to find the accuracy.

3.5.3.2. Keras

A common tool to add to Tensorflow is Keras, an API framework for deep learning and efficiency within the neural network code [80]. It allows for parallel functioning for many GPUs to be consecutively used and deploying is very feasible. There are two types of layers within Keras: Sequential and Model. The Sequential model is layers placed upon one another. Each of the layers are trained and compiled [81]. The Model class is where the layers are grouped and formulated from inputs and outputs [82].

```
1  from tensorflow import keras
2
3  inputs = tf.keras.Input(shape=(3,))
4  x = tf.keras.layers.Dense(4, activation=tf.nn.relu)(inputs)
5  outputs = tf.keras.layers.Dense(5, activation=tf.nn.softmax)(x)
6  model = tf.keras.Model(inputs=inputs, outputs=outputs)
7  |
```

Figure 48 - Keras usage example

This code snippet calls the Keras API to create a model from inputs and outputs. This is used alongside Tensorflow to eventually formulate the predictions.

3.5.4. Audio Processing

There are several different ways of to process the audio input from the Bluetooth module, and transform that input into a visual experience, however, realistic constraints, like time and cost, might have a negative impact on the technology that can be used for high quality, complex and immersive visualizations. Nevertheless, it is important to explore the all options available.

3.5.4.1. Using an Audio File

The product takes in an input, mostly in the version of a .wav file. A WAVE (Waveform Audio File Format) file is a Microsoft RIFF for the storage of digital audio files as data chunks [83]. There are two ways this is stored, a *fmt* chunk and a data chunk. The *fmt* chunk is the file formatting aspect and the data chunk is the actual raw sound data [84]. As seen in the figure below, this is a detailed low-level diagram on how the file is interpreted byte by byte. In Python, there is a wave library, which allows for interface with the file. Any music or sound manipulation will have to go through the WAVE file. Users can send their selection in via downloaded music or any streaming service.

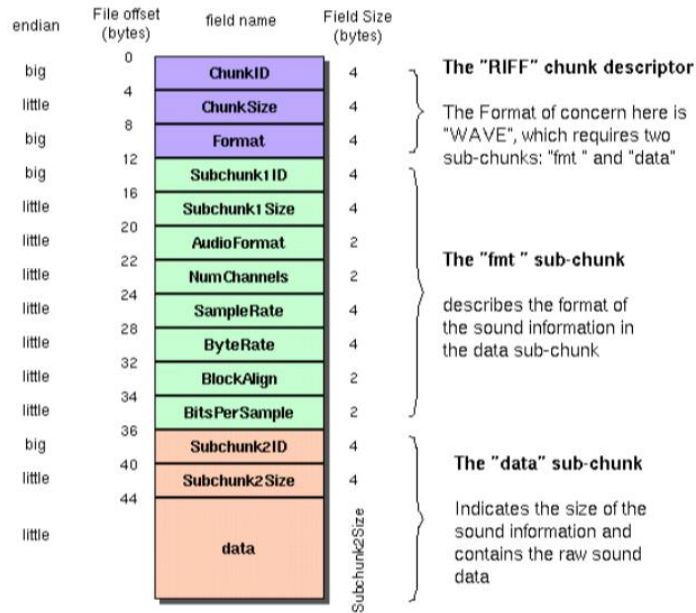

Figure 49 - The Canonical WAVE File Format

Music scrutiny is an essential aspect for the music to visual transversal. LibROSA is a library that analyzes audio, which can gather the specifics of a piece of sound. It can receive tempo, frequency, beats, frames, etc. and perform spectrogram decomposition. There are even advanced options for examining *fourier tempograms* and filters to alter the audio. LibROSA will be an essential library for changing colors or shapes upon tempo, frequency, and, as a stretch goal, possibly filters as well. [85] It will also be a tool for checking if our sound is being read correctly.

A huge factor in music is the pitch, high or lowness of the tone. A library called pcsets scans for the pitch in a song. It was developed by Google software engineers and has last been updated in 2007. Pitch will have a huge factor in determining the colors of our visual. There are 12 pitches within a piece of music and the library gathers this from the scales and chords [86].

Sound files are sent in chunks, as aforementioned, and in specifically the data chunk was the raw format of the file. The Soundfile library scrutinizes soundfiles, as the name shows, and has specific data format and channels. It can read the data being transmitted and even allows for FLAC, OGG and MAT files. The music will continue to be analyzed as long as this library is set [87].

In order to show the process of sound to visuals is actually working, the discrete-time fast fourier transform (FFT) is required [88]. FFT is when an N point time domain signal is transferred to a N frequency domain signal with each having a single point. FFT allows for inspection of the timbre, or quality of sound based off pitch. Scipy has a specific function that can achieve the FFT of a signal [89]. When utilized with Matplotlib, a data visualization library in Python, it allows for testing that our signals are being interpreted by our code [90].

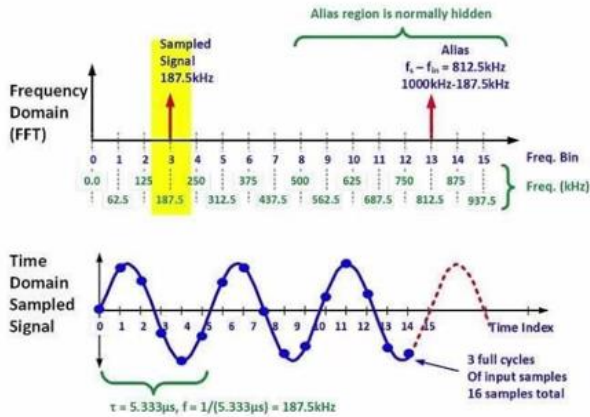

Example FFT

$f_s = 1\text{Msps}$	Sampling Rate
$N_{\text{samp}} = 16$	Number of Samples
$\Delta f = \frac{f_s}{N_{\text{samp}}} = \frac{1\text{Msps}}{16} = 62.5\text{ksps}$	Frequency Resolution
$\Delta t = \frac{1}{f_s} = \frac{1}{1\text{Msps}} = 1\mu\text{s}$	Sampling time
$f_{in} = 187.5\text{kHz}$	Input signal
$k_f = \frac{f_{in}}{\Delta f} = \frac{187.5\text{kHz}}{62.5\text{ksps}} = 3.0$	Frequency Bin
	Note: f_{in} is an exact integer multiple of Δf

Figure 50 - FFT – Different Input Frequency

A musical composition is comprised of notes that collectively create a melody. JythonMusic is a library able to interpret music based off music theory. Although it is mainly applied to music production, it can be manipulated to interpret different parts of a song. On the Jython website, they offer tutorials not only on their code, but on music theory subjects as well. [91]

The device will parse through sound to be able to play music aloud. The wave form of the sound will be translated to a stream that is playable on speakers. Python has a library named Sound device which interprets the input/output of a signal and allows it to be a playable sound. If there is an array bring sent with signals, it will concatenate and translate the signals to music. It works well with streams and larger audio files [92].

As for how the sound will being sent via Bluetooth be played, it will have to be read via the wave file. PyAudio allows for the wave files to be played on any device. It allows for reading and writing of the audio as well as classic interface operations of play and terminate sound. This library will be great for any physical buttons built into the product as well as the website where users can have interaction with their music, especially if they manually import a wave file sound [93].

An in-depth evaluation with training is needed for the software to recognize the notes and chords of each song. A library called Music21 provides a deep analysis into musical notes and frequencies. It can even show the score, time signature, and notes of a song. It also obtains the octave that notes are played in. This is useful for when the device needs to associate various parts of a song to different shapes, colors, and speeds of those transposing [94].

3.5.4.2. Using a Bluetooth Input Stream

Bluetooth operates on the Raspberry Pi 4 where a smart phone device can be connected and send a Bluetooth signal of a sound. Various forums online describe different methods on how to establish a Bluetooth connection with a device. The Pi can be set as an A2DP Sink and a phone can recognize the Bluetooth in settings.

With these steps, a Bluetooth connection can succeed and be establish:

1. Download Pulse Audio:
sudo apt-get install pulseaudio pulseaudio-module-bluetooth
2. Add a user and restart:
sudo usermod -a -G bluetooth pi
sudo reboot
3. Make the Pi discover the A2DP Sink:
sudo nano /etc/bluetooth/main.conf
4. Add or alter to:
Class = 0x41C
DiscoverableTimeout = 0
5. Restart the program:
sudo systemctl restart Bluetooth
6. Start Pulse Audio:
pulseaudio --start
7. Check if the bluetooth works:
sudo systemctl status Bluetooth
8. Test it out with:
bluetoothctl

3.5.5. Audio Visualization

The audiovisual generator of the device is a lengthy process involving an understanding in music theory, color patterns, data visualization, and possibly, machine learning. The images being displayed need to be simple, recognizable, and easily generated in real-time to allow for maximum performance and minimum processing time. AUDIOVISIBLE might contain pre-designed images which are modulated/manipulated according to strict rules and patterns that are measured in the music, however, another option might be to generate the patterns using mathematical functions. These images could as simple as a sinusoidal waveform projection that literally just changes according to the sound, or as complex as a series of concentric shapes whose sizes and curvatures change and move according to the frequencies received.

3.5.5.1. Waveform Simulation

The humblest yet accurate visualization would be that of the sound waves themselves. For computer and electronic engineers, or anyone exposed to an electronics' laboratory, it would be a familiar face, an old friend, an oscilloscope. However friendly it might seem to some, it poses authentic challenges when the audio contains multiple channels, and when the audio changes rapidly. Using a couple of mathematical techniques, like the Fast Fourier Transform to process audio signals and find frequency magnitudes, it might be possible to have this simple visualization implemented within this project's time constraints.

As it may be noticed, the computer rendering of the conceptualized device shows AUDIOVISIBLE displaying a simple sinusoidal waveform that any electrical engineer might see from an oscilloscope when sending an arbitrary signal through it. The first step to bring music to life might be simply to show the input voltage measured from our audio signal. It would require minimal coding, and little-to-no

harmonic analysis. The only indication the viewer would have that the music is changing at all and that the composition is running through different chord structures would be the background colors shown on our screen.

This, however, does not allow for a truly immersive and loyal visual representation of music. AUDIOVISIBLE needs to be able to show somehow that certain registers are being filled with sound, the same way that we as hearing people can hear and feel the difference between a tuba and a flute, or a cello and a violin. the viewer deserves to be able to interpret this information that, although qualitative, can and has been quantified.

3.5.5.2. Graphic Equalization

Many people who listen to music even just casually on their car rides are familiar with the concepts of Treble and Bass. The two most common settings on your car's sound system equalizer (or "EQ") show that your car's sound system is able to distinguish the higher frequencies (treble) and lower frequencies (bass) and apply gain to them according to your preference to improve your music-listening experience. Many cars nowadays even break them up into three parts: Treble, Mid, and Bass, which just allows for even more control of your listening experience. This concept, known as "Equalization" is incredibly prevalent in signal analysis today and is elementary to sound and audio engineers around the world.

The second possibility for visualization could be via "graphic equalization". In graphic visualization, the overall composition is split using linear filters into a series of frequency "bands". These graphic EQ systems vary in bandwidth and number of bands, anywhere from 7 to 31 bands [95]. These bands can be individually modified, (exactly like the ranges in your car) to create the best harmonic structure for any given composition or setting.

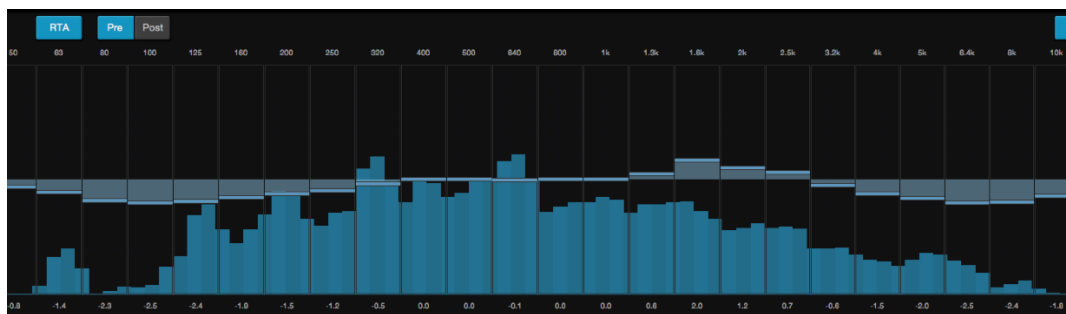

Figure 51: Image from a digital graphic equalizer showing the harmonic breakdown of an audio signal (image taken from presonus)

As our goal is entirely visual, our project has no interest in making changes to a composition. However, this method of distinction between different frequency bands could vary greatly serve the purpose of being the indicator of harmonic complexity AUDIOVISIBLE needs. It shows explicitly how the signal is constructed from different frequencies and can easily be constructed in real-time using linear filters and voltage measurements.

3.5.5.3. Concentric shapes

The most appealing idea we've had was to visualize the changes in the music by showing how a set of concentric circles move relative to one another. Similar to the radial ripple pattern seen when a wave propagates in all directions (like a pebble falling through the surface of water), the outermost ring could expand with the beat of a bass drum, the inner circles could vibrate according to the tones in the higher frequency register. This idea is modeled after the "Pyramid of sound" concept adopted by many western orchestras and choir groups.

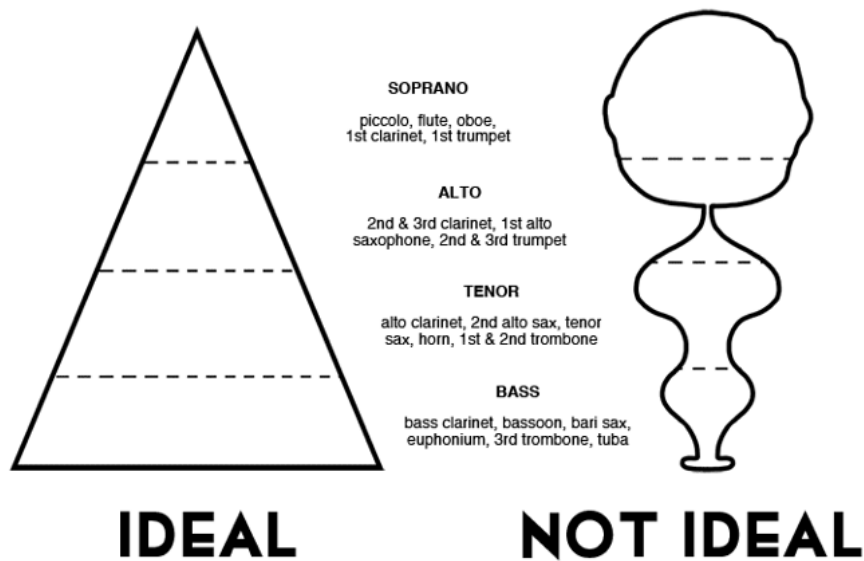

Figure 52 - The Pyramid of Sound

Image copyright 2012 John Bogenschutz www.tonedead.comics.com

The Pyramid of sound describes the balance of the voices in an orchestra [96]. The vertical axis describes the relative pitch of the instrument families, the instruments in the Soprano range (the highest frequency regime) are on top, and the instruments in the Bass range (the lowest frequency regime) are on the bottom. The horizontal axis of the pyramid describes the relative volumes of the instruments in each register. The instruments in the Bass register should be the loudest relative to the others, and the instruments in the Soprano register should be the quietest. If you draw a ring around each register on the pyramid/cone and view it from above, it would look like a series of concentric circles, with the outermost circle being the Bass, the middle circle being the tenor/alto range and the pinpoint being the soprano.

Now that we have a base image for display, animation would simply consist of modulating the radiuses of the circles, as well as turning the edges of the circles into sinusoidal functions. The number of harmonics (and their amplitudes) found in each register could describe the period of the function describing each circle, as well as the amplitude of the sine waves.

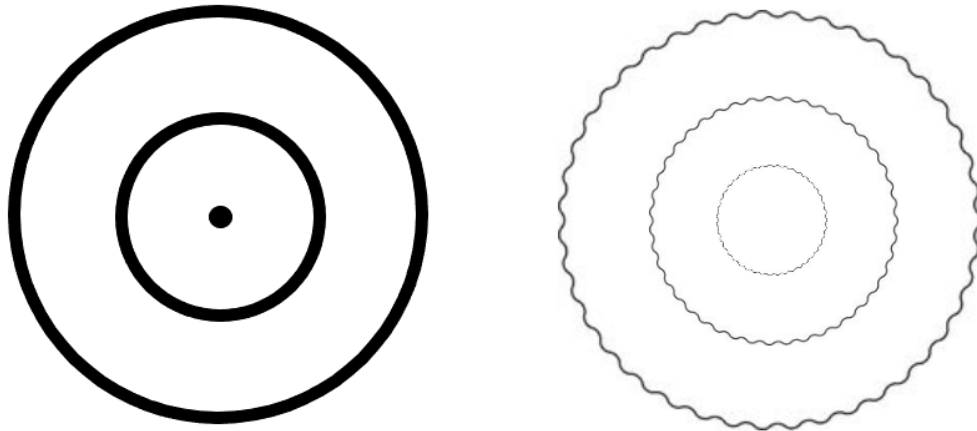

Figure 53 - Concentric circles as an example of what could be possible.

This can easily be mathematically modeled, as each ring is simply an oscillatory correlation between circles of varying radii. This has been modeled/proven to be easy with the very simple graphing calculator software, Desmos Graphing Calculator [97]. When a heavy bass drum is struck in the composition, we see the outermost circle get larger with the beat, and then relax as the drum's tone dissipates. When we hear a piano playing in its higher register alongside a piccolo, the center circle will be vibrating very rapidly, signaling the viewer that there is a lot of harmonic complexity occurring in that pitch range.

Although more geometrically and logically complex, this process could also be done with a myriad of simple shapes, ranging from triangles to dodecagons, depending on what the user (or the developer) wants to see. This could be done instead of circles by defining the edges of the shapes as sinusoidal functions with bounds, and then transforming them using rotation matrices and translations. As a stretch goal, several different geometric designs would already be integrated into the device, allowing for the user to choose their geometric experience.

3.5.5.4. Random Psychedelic Art

For some compiled content, it would require a basic matrix and linear algebra and computer vision knowledge. With a three-function input and a matrix multiplication of $[-1, 1] \times [1, 1]$, an image can be created. For some more original computer vision aspirations, there is Random Psychedelic Art by Jeremy Kun [98]. Random numbers and lambda functions are applied to equations and can result in an engaging and encapsulating array of colors and shapes.

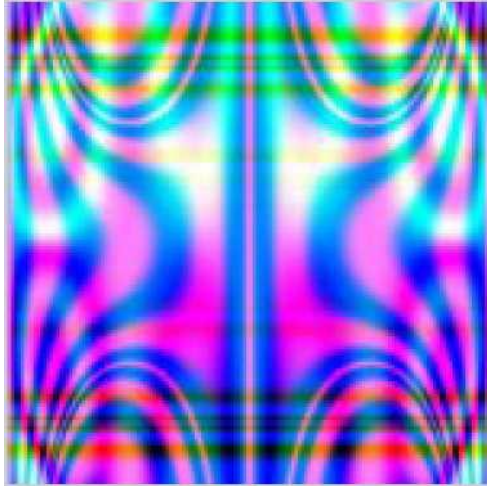

Figure 54 - Random Psychedelic Art by Jeremy Kun.

3.6. Software Tools

To complete the development of the code, various software and technologies were required for completion of the device. Utilizing a mixture of Agile development, DevOps, Digital Circuit Design, and professional programming practices, a foundation and precedence of coding, designing, and testing can be facilitated and ensure better user satisfaction. Sloppiness and unorganized development is avoided with the organization of DevOps and version control systems. With the software, it creates an easier environment for designing and perfecting hardware to coordinate to software and code.

3.6.1. Visual Studio Code

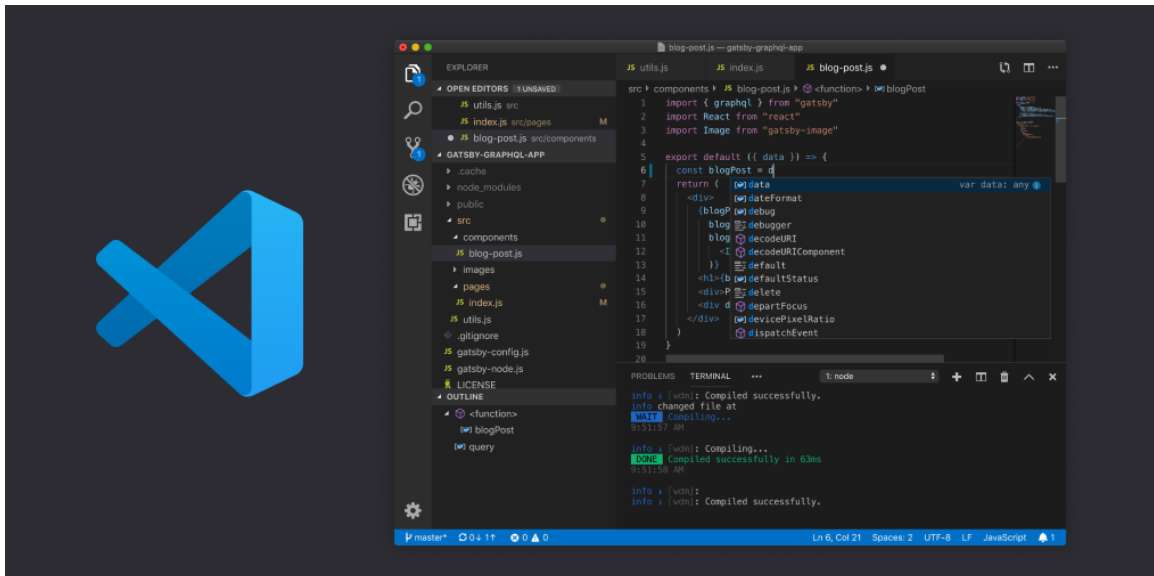

Figure 55: Visual Studio Code Editor [99]

Visual Studio Code is a text editor embedded with a command prompt terminal. It is available on Windows, MacOS, and Linux and has language-friendly capabilities. For the Python script, VSCode will be used partially. With an environment able to operate Python as well as Jupiter Notebooks, not only can Artificial Intelligence coding be completed but, also, debugging and testing can have functionalities as well [100].

3.6.2. Git

Git is an open-source version control system for documents, code, and projects. Git is used to hold the code data for AUDIOVISIBLE so the whole team can operate on different branches at once. It allows for the production file to not be overwritten and well tested before code is merged into that branch. When the code merges, testing will be assured for no bugs [101].

3.6.3. Microsoft Azure DevOps

Microsoft Azure DevOps is a project management tool for the team to contribute to projects and collaborations. Included in this package is Boards, Repos, Pipelines, and Artifacts where planning, assignments, commits, and testing can be conducted. With Git already enabled inside DevOps, it allows for code reviews and multiple commits [102].

3.6.4. Microsoft Teams

Microsoft Teams is a professional form of communication and document sharing where teams can be created, and each have their own files and chat. It allows for collaboration in real-time as well as for multiple chats and posts to be organized. Online meetings can occur on the platform as well and users can schedule meetings. To keep organized, the team had meetings twice a week, one weekday and one weekend day [103].

3.6.5. Eagle

We will use the Eagle software to complete two things, create a schematic and a PCB layout for our project. In EAGLE, back-annotation to the schematic from the board is allowed. Traces in the schematic are automatically connected through the auto routing feature. [104]

Auto routing will be a major assistance while developing an efficient design. Auto routing allows me to optimize my design as I constantly add more components and creatively connect them together to avoid conflict. There are multiple ways to design a PCB and a few factors to consider while creating your design, like spacing, layered connections, and compatibility. This process can be either simple or complex, so auto routing works as a helping hand to suggest possible connections when we get stuck and not know what to do next. With the complexity of the design, it becomes easy to have critical connections, so adjusting spacing and rewiring will be needed. Auto routing will first identify the critical connections and potential help with the rewiring process to solve that problem. [105]

PCB design review is extremely important thing because it reduces an amount of time and development costs. When designing and creating a prototype goes wrong

it cost more money to order a new one and take up production on time to wait on it to get in your hands. If reviewing the design is taken seriously, by constantly checking the layout, looking for errors, discrepancies, missing components, wrong connections, and making sure the schematic design is what was meant to be design, it could really do a lot. [106]

3.7. System Housing

The AUDIOVISIBLE device, is meant for indoor use, therefore it should be externally tasteful, minimalistic and of neutral colors. This artifact comprises six surfaces, with the front facing surface being mostly a rear projection screen, or translucent fabric. The requirements for carbon neutrality, cost effectiveness and weight, are considered in the material selection and constructions process.

3.7.1. Housing Materials

The housing materials are to be used in the construction of the outer enclosure, internal placements for the electronic and optical components, as well as the covers for the speakers.

3.7.1.1. Outer Enclosure

- **Bamboo:** Bamboo is not wood, but a grass with no woody material in its stem. The round, hollow stem, with closed sections every foot or two, is sawn lengthwise into long narrow strips that are then made into rectangular-cross-section pieces that take out the curvature. The strips are then edged glued together into veneer and glued into "plywood" panels that looks like and behave much like wood.
- **Basswood:** malleable and inexpensive, this is the most popular wood choice for wood carving beginners, used in woodworking for centuries, has almost no grain and is very soft. It is also popular in lower cost musical instruments, making up the bodies of some woodwinds, and electric basses and guitars. Basswood blanks can be found easily.
- **Other possible woods:** besides Bamboo and Basswood, other Walnut, Ash, and Ebony
- **Recycled materials:** while having beautiful woods would make the construction process easier, one of the constraints is to have a product that has a low carbon footprint. In lieu of this, thought has been given to used and broken items, that could be used instead for the outer enclosure. Among the considered items are acoustic guitars, cassettes, vinyl records, pieces of furniture, and vintage tube television sets.

3.7.1.2. Internal Platform for Electrical and Optical Components

Regardless of the material chosen to put the electronic and optical components on, for safety reasons, these components will be attached to the surface with the use of stands to leave an air gap and separate the materials.

- **Same wood as the outer enclosure:** probably the easiest option, it would put the delicate electronic devices too close to the outer shell of the device. To

fix this, adding a layer of some cushioning or damping material, could ensure that the inner systems stay safe in case of mishandling or drop.

- Aluminum: used in many computer towers cases and laptops, this light metal is non-conductive and sturdy.
- Plastic: the ideal candidate if a 3D printer is available. Plastic is non-conductive and easy to work with, however the resistance to varying temperatures might prove a risk too great to consider. Different kinds of plastics would offer different temperature resilience, and also an opportunity to use recyclable materials to comply with the low carbon footprint requirement.

3.7.1.3. Speaker Covers

- Acoustically transparent fabrics: this is a type of fabric that allows the sound waves to freely move through it. Acoustic transparency is a concept related to maintaining acoustic fidelity as sound passes through the fabric. Some of the available options are Cotton Sheer Muslin and Linen Cyclorama.
- Metallic mesh: usually implemented in land vehicles, or in big stand-alone speakers, the metallic mesh, or grille, is the strongest and most protective option available.
- Outer enclosure: in this case, a carved or laser-cut pattern on the material of the outer enclosure itself, with an acoustically transparent fabric on the inside.

3.7.2. Projection Screen

Projector screens come in all shapes and sizes, and they can vary in color, as well. Screens are available in shades ranging from bright white to very dark gray (sometimes marketed as “black”). Multiple considerations must be taken when it comes to selecting the correct rear projection material. Many variables including lighting, lighting control and image contrast will impact what color screen is ideal for AUDIOVISIBLE. Another consideration is that a projector can’t project the color black, and instead, in order to create the illusion of black, the projector would not project anything. This is a challenge in rooms where total darkness is not possible, and darker (not white) fabrics are recommended.

3.7.2.1. Cotton and Polyester

After reviewing several DIY projects online, and physically testing fabrics made of cotton, polyester, and cotton-polyester blends, only two configurations would work for good quality rear-projection:

- Tulle: a lightweight, very fine, stiff netting that can be made of various fibers, particularly polyester, which is the most common fiber used for tulle. Tulle is most used for veils, gowns (particularly wedding gowns), and ballet tutus. Tulle comes in a wide array of colors and it is readily available. Gowns are often puffed out with the use of several layers of stiff tulle.
- 30% Cotton 70% Polyester: a common blend for clothes and bed sheets, this fabric allows enough light to go through it, however the resolution is not as good.

3.7.2.2. Rear Projection Screen

Considering only the available commercial screens for home projection, this section focuses on rear projection screens.

- Gray Rear Film: Translucent and slightly gray, it gives the brightest image available in a rear projection material, which is ideal for environments with some ambient light. In dark environments, however, care must be taken to avoid hotspots. Avoid projectors that are too bright or that project in direct line-of-sight to the viewer.
- White Rear Film: Very similar to the Gray Rear Film, the white rear film is opaquer, which helps make the images more uniform when paired with brighter projectors. Slightly dimmer than gray rear film but more even in its light distribution, making it a great choice in dark environments.

3.7.2.3. Paper, Plastic, and Glass

In the case of LEDs or lower intensity light sources, a clearer or more translucent option should be available, aside from fabrics and screens.

- Paper: this material comes in a wide array of options, and within those options, translucent paper would be ideal for rear projection. Glama Natural Vellum is a premium translucent paper that is popular for creative crafts of all sorts. It has the appearance of frosted glass, just slightly masking what is beneath it. Temperature and light intensity considerations need to be observed, due to its high flammability.
- Plastic: modernity has brought probably a wider array of options in plastic, when compared to the honorable paper. In the same manner, for rear projection, a simple translucent plastic that allows enough light to get through would be ideal for this. Acrylics and other glass-like plastics could be used by just applying a simple coat of paint to the material. The malleability of this material is both its appeal and disadvantage, trading ease of construction with durability.
- Glass: and particularly, tinted glass, could be a beautiful and classic medium to project the light upon. Fragility, however, makes this material less desirable. Almost all light-transmitting devices encountered in the western home of the twentieth century, utilized glass as the preferred material of construction, however, this made devices bulky and heavy.

3.7.3. Construction Process

Any construction process is heavily reliant on the materials and techniques used. This section explores two different techniques in times of a virus pandemic where shops are closed, companies are closing doors, or lead times are unacceptable, few options are available.

3.7.3.1. Hand made

A hand made item, is usually priced above others not only for the intrinsic higher value that a non-industrialized item carries, but mainly due to the fact that another human being invested time, attention, talent, thought, and emotion, into every action leading to the construction of the device.

In the case of AUDIOVISIBLE, the process of constructing the prototype might undergo several iterations and adaptations in order to make it right. This device is not required to be produced at a massive scale, nor to a consumer ready state, therefore some artistic liberties can be taken, while staying within the boundaries set by the requirements and constraints of the project.

3.7.3.2. 3D Printing

Not everything can be easily hand made, and many internal components might require some 3D printing. 3D printing, or additive manufacturing, is the construction of a three-dimensional object from a CAD model or a digital 3D model. The term "3D printing" can refer to a variety of processes in which material is joined or solidified under computer control to create a three-dimensional object, with material being added together, typically layer by layer.

3.7.4. Conclusion

In summary, all choices were largely decided upon due to the scarce availability of variety of materials during the 2020 pandemic, and due to the unexpected economic constraints on the budget of the project due to the same pandemic. Maybe a bit more creativity would be required, but no setbacks are expected.

Feature	Choice	Reason
Outer Enclosure	Recycled Materials	Cost and availability
Internal Platform	Outer Enclosure Materials	Cost and availability
Speaker Covers	Outer Enclosure	Cost and availability
Projection Screen	Gray Rear Film	Projected image quality
Construction Process	Hand made	Cost and availability

Table 12 - System Housing Summary

4.0. Standards and Realistic Design Constraints

In this section of the paper, we will go over the related constraints and standards of the AUDIOVISIBLE device. This project will need to meet the standards provided from the various components being utilized. Several constraints applied to this device deal with the need for a cost-effective product that is easy to use, follows the path that other designs have utilized, and brings a new experience for an underserve community.

4.1. Standards

A standard refers to an established way of doing things. This section will cover the relevant standards that are required to study and follow in order for AUDIOVISIBLE to healthily and safely function in an average modern American household. There are different levels of interaction with standards: user, implementation, and development. At the user level, the standards are simply employed in the design, while technical knowledge of the standard is not typically necessary. At the implementation level, details of the standard need to be understood, and at the development level, standards are being developed, created, updated [107]. In this section, the focus will be at the implementation level.

4.1.1. Hardware

This project uses a wide span of technologies, each of which have their own standards which they need to meet. In this section we will discuss the various standards imposed on the physical components of the project, including the powering of the device, operation of Bluetooth communications systems, and the safety and health concerns related to lasers and the optical system which they illuminate.

4.1.1.1. Bluetooth

Bluetooth is a short-range wireless communication technology standard that allows [108]. Bluetooth allows devices like mobile devices and PCs to transmit data or voice over a short distance, wirelessly. It uses short-wavelength UHF radio waves in the ISM band from 2.4 to 2.485 GHz. Bluetooth was invented by Ericsson, a networking and telecommunications equipment and service company (1994). The company is now being ran by SIG, Bluetooth Special Interest Group.

The purpose of Bluetooth is to have a connectionless relationship between devices, while keeping a secure communication for transmission. In short, Bluetooth is a wireless replacement for cables. Like other wireless replacements, it uses the 2.4GHz in a home or office, like WIFI routers. It creates and personal area network (PAN), a short-range network that allows you transmit data wirelessly between two and eight devices.

The attractive thing about Bluetooth is that it uses less power and cost less to implement than WIFI. The low power feature allows it to be less prone to interference with other wireless devices in the 2.4GHz band.

Bluetooth has different versions releases available. This project will be use Bluetooth 4.x or Bluetooth Low Energy. This version supports collecting data from

low energy devices, such as almost all wearable devices or smart home appliance. Additional features consist of features for the internet of things (IoT), privacy updates via firmware, and increase support for LTE, bulk data exchange rates.

Bluetooth LE facts:

- Range: 150 meters open field
- Output Power: 10mW
- Max Current: 15mA
- Latency: 3ms
- Topology: Star
- Connections: >2 billion
- Modulation: GFSK @ 2.4 GHz
- Robustness: Adaptive Frequency Hopping, 24bit CRC
- Security: 128bit AES CCM
- Sleep current: 1 A
- Modes: Broadcast, connection, Event Data Model Reads, Writes
- Data Throughput: 1 Mbps

4.1.1.2. Power

Based on the World standards, in the Unites States of America the standard for transporting electricity is a voltage of 110V and a frequency of 60Hz [109]. Electricity is produced in generators at a Generating station or power plant. The generators convert the energy from mechanical to electrical by forcing electric current to flow through an eternal circuit. At the station, electricity is produced at 30 kV, then the voltage is increased by transformers to enter transmission lines to be carried for long distances. The electricity stops at a transmission substation for maintenance and Distribution lines for reduces voltage for local distribution. Power is usually distributed through alternating current (AC) or alternatively, direct current (DC). It is AC that flows in a standard frequency of 60 Hertz in the North America. Even though DC could be used to transport electricity over long distances, it doesn't cycle or change distances. So, DC must be converted back to AC to be stepped down at distribution stations.



Figure 56 - NEMA 1-15R (Socket A)



Figure 57 - NEMA 5-15p (Socket B)

The NEMA 5-15p is the standard wall outlet in North America for homes and businesses. The USA uses NEMA 1-15R and NEMA 5-15p wall mount. All NEMA 1-15R plugs can fit both NEMA 1-15R and NEMA 5-15p wall outlets. [110]There is no alternative for socket A but you can use Socket A in Socket B. If living in North America, plug adapters are usually not needed, so customers will have access to all wall outlets to power devices and appliances.

4.1.1.3. DMD (DLP chipset)



Figure 58 - DLP230NP DMD

The DLP chipset is an array of highly reflective aluminum micromirrors, also known as the digital micromirror device “DMD” [111]. The DMD is a system with an electrical input and an optical output micro-electrical-mechanical system (MEMS). With this technology it is possible to perform very fast, proficient, and stable spatial light modulation. A DMD contains up to 8 million individually controlled micromirrors built on top of a related CMOS memory cell. The DMD controller loads memory with a ‘1’ or ‘0’, then a mirror reset pulse occurs, this is associated to a +/- degree state. The + degree represents ‘on’ and – degree represents ‘off’ for a projection system.

DLP chipset:

- DMD – Digital micromirror device

- DMD Controller – provides the convenient interface for a stable, and high-speed control of micromirrors
- DMD Micromirror Drivers – deliver analog clocking and reset signals
- Configuration PROM - configures select DMD Controllers

4.1.1.4. Laser Classes and Eye Safety

Lasers are highly coherent, monochromatic, very powerful light sources. They are used in all kinds of settings, from “low-power” laser pointers in the classroom, medium-power lasers in lab settings, to high power ablation lasers being used in surgical settings and manufacturing. Lasers come in many shapes, sizes, wavelengths, and outputs. The latter two are the most important qualities to consider when discussing safety.

Due to the wide variety of laser wavelengths and powers available, they have been categorized into four classes (with subclasses), each one classified according to a maximum power output (known as the “accessible emission limit”), and each emission limit is assessed according to wavelength and exposure time. The classes are numerically assigned, starting with class 1 (no hazard during normal use) to class 4 (severe hazard and risk of bodily harm).

Class 1 is considered relatively “low power” and is generally safe to view directly or without assistive optics (like glasses or lenses).

Class 2 is also considered relatively “low power” but should **not** be viewed directly with or without magnifying optics, and certainly not without protective eyewear.

Class 3 is where we start to breach what is considered hazardous to human health. You should never allow this to shine directly into your eye under any circumstance.

Class 4 is the most dangerous class of laser. Even the scattering from class 4 lasers is considered dangerous to the eyes and the skin.

You can see a much more in-depth informational graphic from LaserPointSafety, including FDA regulations and how they pertain to ANSI and IEC laser classifications on the next page.

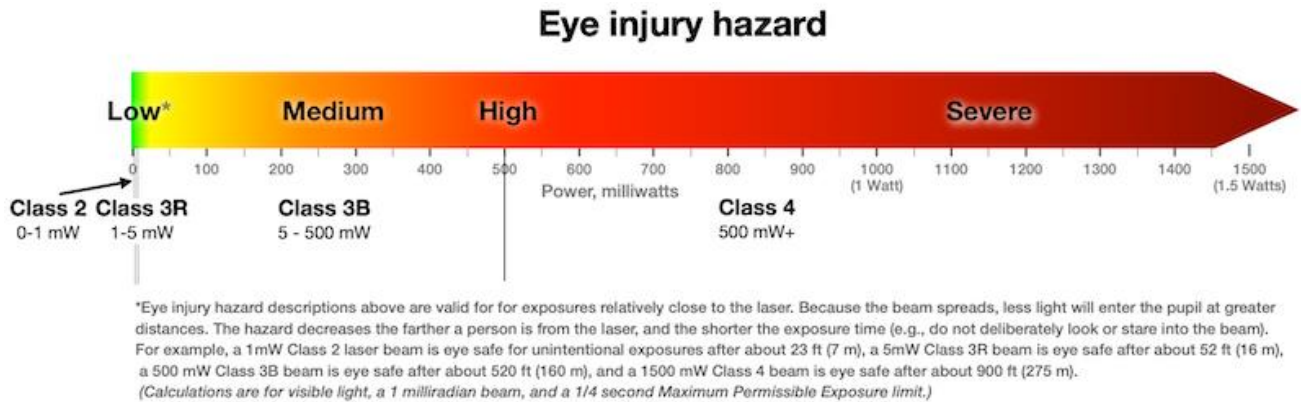

Figure 59 - A chart correlating each laser class and its potential severity of injury [112]

ANSI and IEC laser classification	Class 1		Class 2		Class 3		Class 4
	Class 1	Class 1M	Class 2	Class 2M	Class 3R	Class 3B	Class 4
	Class I	No special FDA class	Class II	No special FDA class	Class IIIa (definition is different but results are similar)	Class IIIb	Class IV
Human-accessible laser power (for visible light)	For visible light, emits beam less than 0.39 milliwatts, or beam of any power is inside device and is not accessible during operation.		Emits visible beam of less than 1 milliwatt.		For visible light, emits beam between 1 and 4.99 milliwatts.	For visible light, emits beam between Class 3R limit (e.g. 5 milliwatts) and 499.9 milliwatts	For visible light, emits beam of 500 milliwatts (1/2 Watt) or more
Caution/warning indication	No special caution/warning indication		No special caution/warning indication		CAUTION	WARNING	DANGER
Label descriptive text		DO NOT VIEW DIRECTLY WITH OPTICAL INSTRUMENTS	DO NOT STARE INTO BEAM	DO NOT STARE INTO BEAM OR EXPOSE USERS OF TELESCOPIC OPTICS	AVOID DIRECT EYE EXPOSURE	AVOID EXPOSURE TO BEAM	AVOID EYE OR SKIN EXPOSURE TO DIRECT OR SCATTERED RADIATION
EYE AND SKIN HAZARDS							
Eye hazard for intraocular exposure (having a direct or reflected beam enter the eye)	Safe, even for long-term intentional viewing. For visible light, usually applies when the laser is enclosed inside a device (ex: CD or DVD player) with no human access to laser light.	Safe for unaided eye exposure. May be hazardous if viewed with optical instruments such as binoculars or eye loupes.	Safe for unintentional exposure less than 1/4 second. Do not stare into beam.	Safe for unintentional (< 1/4 sec) unaided eye exposure. May be hazardous if viewed with optical instruments such as binoculars or eye loupes.	Unintentional or accidental exposure to direct or reflected beam has a low risk. Avoid intentional exposure to direct or reflected beam.	Eye hazard; avoid exposure to direct or reflected beam.	Severe eye hazard; avoid exposure to direct or reflected beam.
Maximum or typical Nominal Ocular Hazard Distance (for 1 milliradian beam, exposure time less than 1/4 second)	Not an eye hazard -- does not apply	Consult an LSO as described in the Technical Note below	NOHD of 0.99 mW beam: 23 ft (7 m)	Consult an LSO as described in the Technical Note below	NOHD of 4.99 mW beam: 52 ft (16 m)	NOHD of 499.9 mW beam: 520 ft (160 m)	NOHD of 1000 mW (1 Watt) beam: 733 ft (224 m). NOHD of 10 W beam: 2320 ft (710 m)
Eye hazard for diffuse reflection exposure (looking at the laser "dot" scattered off a surface)	None	Consult an LSO	None	Consult an LSO	None	Generally safe. Avoid staring at the laser "dot" on a surface for many seconds at close range.	To avoid injury, do not stare at laser "dot" on a surface. The light is too bright if you see a sustained afterimage, lasting more than about 10 seconds.
Skin burn hazard	None	Consult an LSO	None	Consult an LSO	None	Can heat skin if beam is held long enough on skin at close range	Can instantly burn skin. Avoid direct exposure to the beam.
Materials burn hazard	None	Consult an LSO	None	Consult an LSO	None	Can burn materials if beam is held long enough on substance at close range	Can instantly burn materials. Avoid direct exposure to the beam, for materials susceptible to burning.

Figure 60 - Infographic breaking down the four different laser classes, their subclasses and how to treat them as safety hazards according to the FDA. [112]

4.1.2. Software

Software poses many vulnerabilities to a newly published product or application. Without proper security or clearances, a software can have unexpected bugs, where people can take advantage of them. To ensure that errors or inconsistencies in the code do not occur, professional coding practices and testing will be utilized. Standard naming conventions, explanations of code in comments, descriptive function names, and simplified structure are required for clear communication and product quality [113]. With organized methods of software standards, it is cost-efficient for timing of code and allows for less confusion. Some personalized standards, according to team agreement, will be implemented with more reporting and checklists to guarantee top-notch quality. Less global variables, defined

heading structure, and indentation as well as low runtime and memory allocation are huge to how the code operate. Ideally, keeping memory and speed low will allow for even an enhanced performance on the hardware [114].

4.1.2.1. Bluetooth

Bluetooth holds a critical standard within the IEEE society called IEEE 802.15.1-2002 within Wireless Personal Area Networks (WPAN). It is maintained under standards due it's low-powered, low range connection utilizing radio frequencies. It is a technology open to public usage and royalty-free, meaning anyone can have or operate with this technology at no cost. With just one Bluetooth device, it is possible to have control over multiple devices simultaneously. It also leads to the ridding of extraneous wires and cables. Bluetooth can be enabled with voice, body, and data controls, which can allow for the communication of various devices at once. Bluetooth has a frequency that is accessible to anyone in the world and has an unmonitored frequency band [115] [116].

4.1.2.1.1. Advanced Audio Distribution Profile (A2DP)

This profile defines how multimedia audio can be streamed from one device to another over a Bluetooth connection (it is also called Bluetooth Audio Streaming). The Audio/Video Remote Control Profile (AVRCP) is often used in conjunction with A2DP for remote control on devices such as headphones, car audio systems, or stand-alone speaker units. These systems often also implement Headset (HSP) or Hands-Free (HFP) profiles for telephone calls, which may be used separately.

Each A2DP service, of possibly many, is designed to uni-directionally transfer an audio stream in up to 2 channels, either to or from the Bluetooth host. This profile relies on AVDTP and GAVDP. It includes mandatory support for the low-complexity SBC codec (not to be confused with Bluetooth's voice-signal codecs such as CVSDM), and supports optionally MPEG-1 Part 3/MPEG-2 Part 3 (MP2 and MP3), MPEG-2 Part 7/MPEG-4 Part 3 (AAC and HE-AAC), and ATRAC, and is extensible to support manufacturer-defined codecs, such as aptX.

Some Bluetooth stacks enforce the SCMS-T digital rights management (DRM) scheme. In these cases, it is impossible to connect certain A2DP headphones for high quality audio.

4.2. Realistic Design Constraints

To build a novel implementation of a spectrum analyzer, as with any engineering endeavor, there will be several constraints. Some of these limitations will be imposed by the nature of the universe, like the speed of light or gravity; others might be imposed by the dimensions of where and when the project will be implemented, like the target culture and community, time of release to market, political situation, or as rare but real as a pandemic; ethical, health and safety can determine if the product could be banned; but the greatest constraint will be the self-imposed ones, conscious or unconscious, like the general knowledge of the project, the understanding of the engineering needs being satisfied, or unknown individual bias factors like preference of using one brand versus another.

4.2.1. The Pandemic

At the time of writing, researching, developing, and constructing this AUDIOVISIBLE device, our modern world has been afflicted with a health crisis, a pandemic. Although relatively sparse throughout our short history as homo-sapiens, pandemics have been a recurring event in our human experience, and every time, causing major disruptions to our way of life. This time is not different, and we face shortages of parts and components, lack of access to some necessary manufacturing processes and equipment, delays in shipments, and reduced customer support. The availability of some parts and services change from day to day, and the need for several variations in design options are required, with imminent and always present adaptations. This viral pandemic now has ripple effects in our interconnected modern world and influences all other constraints in ways that are difficult to articulate and anticipate.

4.2.2. Economic and Time constraints

Budgetary and deadline constraints will play a key role in the different design variations present in this device. Placing these constraints in the context of a reduced availability of certain required electronic components due to the pandemic, means that some budget changes or use of recycle parts might be the only way to complete the project in time. The overall initial budget is \$750, without sponsorship of any kind. All the costs associated with the construction materials, input and output technology, electronic controllers, optical components, and prototyping-related tools will be completely funded by the group of engineers behind this project. Due to the current economic recession, has a negative effect in the availability of some of the low-cost components used, namely the chosen Digital Micromirror Display, which can't be found at its original price of \$50, but starting at almost twice its price. There are certain discounts based on price breaks from the purchase of bulk quantities, that are not applicable at this stage of the product.

From a timing perspective, there are very specific deadlines that need to be accomplished, all related to the successful completion of academic milestones in order to complete this project by December 2020. In order to meet these time constraints, a specific design, process or method might be chosen over the other, regardless of the quality of the result of one, versus the other.

4.2.3. Environmental, Social, and Political constraints

AUDIOVISIBLE is an indoor product for an underserve audience, and this implies very specific design constraints. A minimalistic approach, using simple opaque colors on the surface is needed to be able to be placed in any room and be visually engaging while being utilized. The choice to use a technology like Bluetooth, was reached when considering the social interactions between the product and the audience, knowing how common, and almost inherent, a technology like Bluetooth is for any kind of wireless sound system. However, a special consideration for the deaf and hard of hearing must be made, because the use of this device might be the first exposure to the Bluetooth technology, which is predominantly used for audio-related devices.

4.2.4. Ethical, Health, and Safety constraints

AUDIOVISIBLE is an experience to be enjoyed through the eyes and/or hears of the audience, and special restrictions are observed regarding the projection technologies used. The use of powerful light projection or lasers was discarded due to the potential damage it could inflict in eyes of the viewer. Small speakers, enough for a wider audience to enjoy the music, are specially selected to bring quality sound and volume that would not damage the hearing of the user. According to the CDC, a “noise above 70 dB over a prolonged period of time may start to damage your hearing.”¹¹ From an ethical perspective, it is the mission of this project to bring an audio experience to individuals who have no audio capabilities, and the authors consider this motive ethically sound.

4.2.5. Manufacturability and Sustainability constraints

Construction of any kind during a worldwide economic and health crisis, is a challenge to be met with special and particular efforts. Using sustainable approaches and recycled materials is necessary, not optional. The system housing or external casing, is made of recycled wood, manually assembled. The screen is a common rear-projection fabric made of a material that is not recycled, however, the optional use of cotton and polyester cloth might be used as a replacement and it can come from an entirely recycled source. The electronic and optical components can be found and bought online, but precise microcontroller assembly requires access to especial tools and equipment. Access to these tools and equipment is limited because the community maker areas are closed to the public, the laboratories at the university have limited access, and cost of these tools and equipment are out of reach to the authors of this paper.

5.0. Project Hardware and Software Design

Now that we've laid out all our requirements and specifications, discussed the standards we need to adhere to, and researched all the technologies and devices that can be of use to us in achieving our goal, it is time to finally put together an in-depth documented prototype design for AUDIOVISIBLE. In this section we will go into detail about the devices we intend to use, how they will fit together, communicate with one another, and work toward creating a true music visualizing product.

We will first discuss the hardware design, including details and schematics for the housing of the device, optical and display controller assemblies, power subassembly, optical engine, and audio assembly. We will then delve into the software design, including block diagrams for information flow, discussion of the language in which AUDIOVISIBLE will be coded, and our plan for wirelessly deploying software and updates to the device while on the field for testing and demonstration.

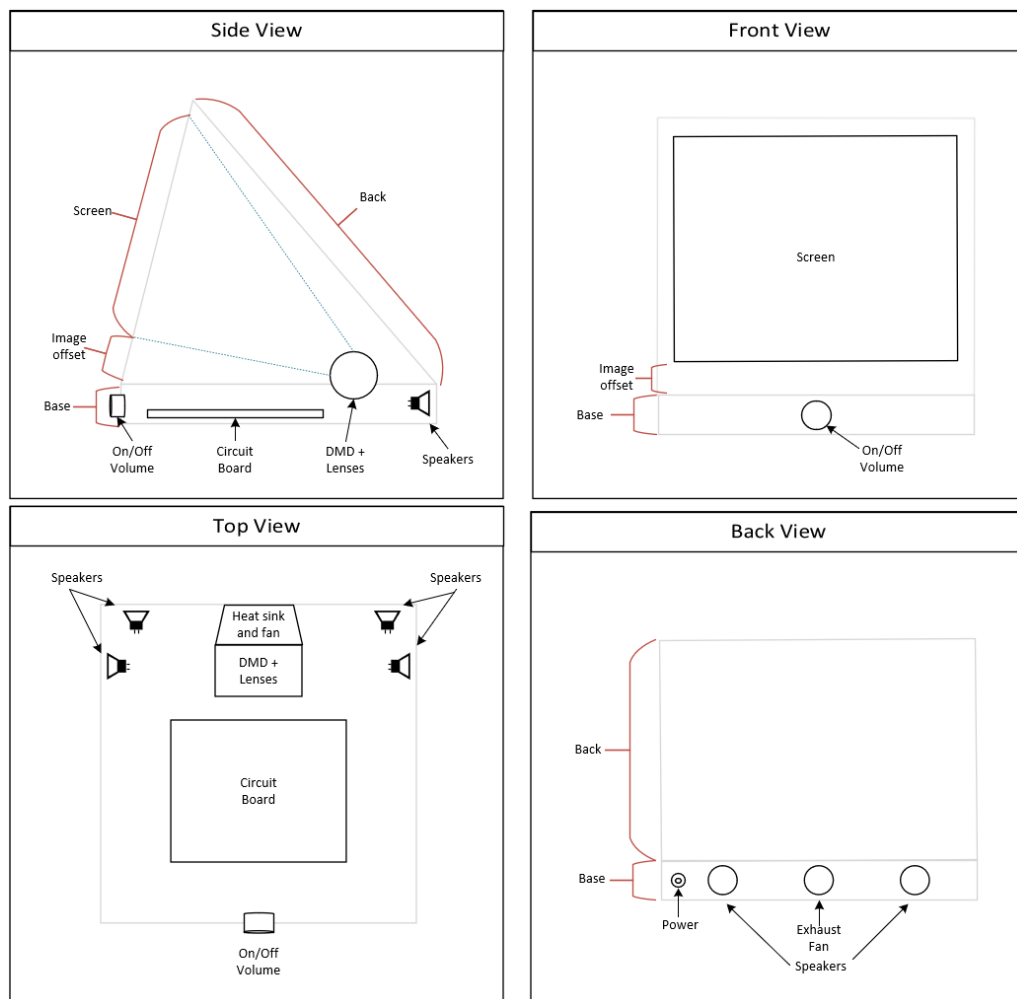

Figure 61 - Initial Product Schematic

5.1. Optical Controller Assembly

The block diagram below shows that the DLP Pico chipset consists of three chips: DLPC34xx controller, Power Management Integrated Circuit (PMIC), and the DMD. The DMD, is an optical micro-electrical-mechanical system (MEMS) that contains an array of highly reflective aluminum micromirrors. These microscopic mirrors toggle rapidly as they are “powered-up” and “powered-down”. The DLP chip controller enables the operation of the DMD. Controllers provide a convenient, multi-functional interface between user electronics and the DMD, enabling small form factor and low power display applications. The PMIC, are highly integrated circuits, that contain power rails and power management functions on a chip. This chip is commonly used to power small, battery-operated devices like the DMD. Different types of functions joined into a PMIC are voltage converters, voltage regulators, battery chargers, power control, and LED drivers. In this project, a low powered PMIC will be used, because they provide the high efficiency and have the capability to power space-constrained applications.

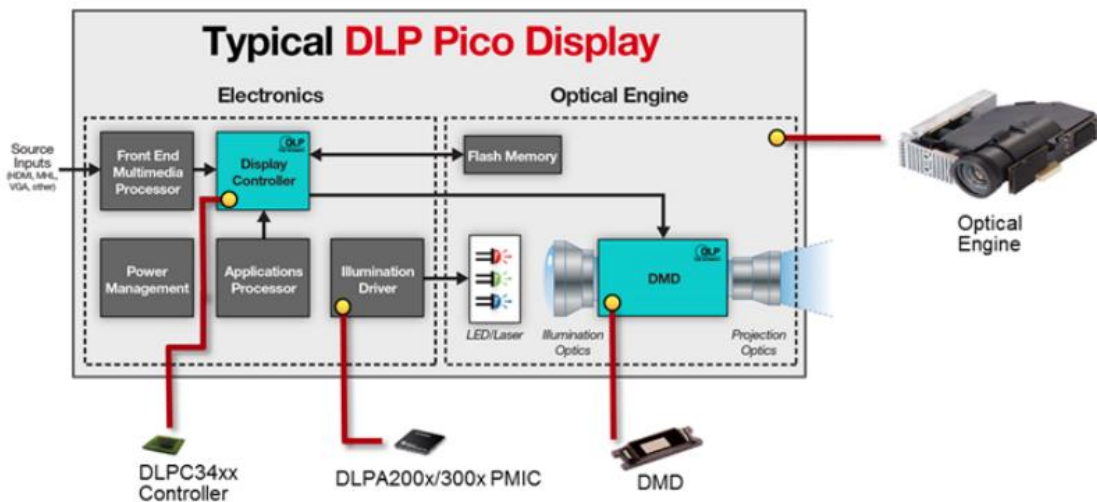

Figure 62 - Typical DLP™ Pico System Block Diagram

5.1.1. Display Controller

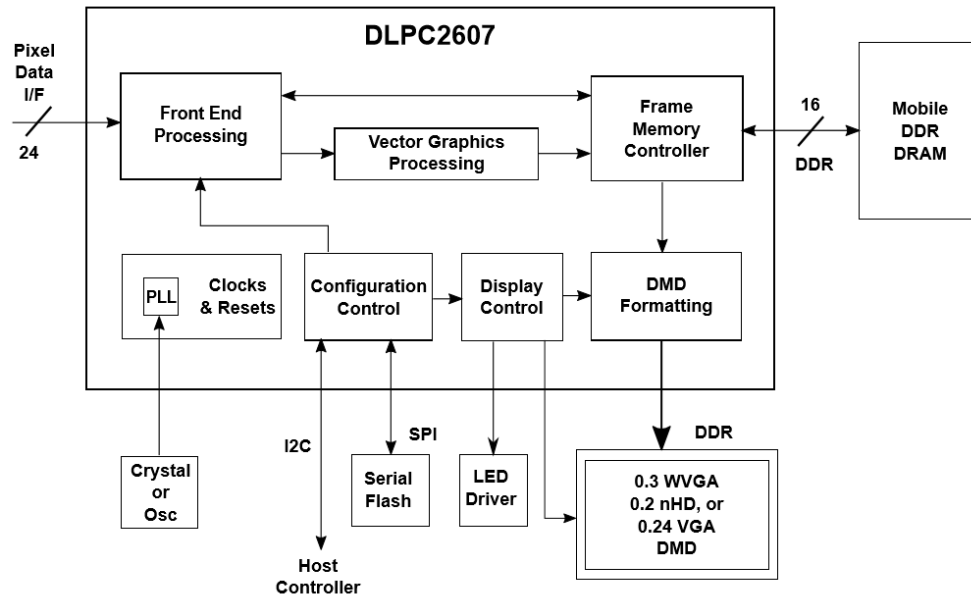

Figure 63: DLPC2607 Block Diagram showing internal processing and input and output functionality

The DLPC2607 display controller allows for image and data processing functionality for tiny forms and low power production. It works well with the 0.3-WVGA, 0.24-VGA and 0.2-nHD DMDs and improves performance and reliability of the DMD. Examples where used are mobile projectors and interactive displays and has operations with VGA, HDMI, USB, SD, etc. With the aforementioned DMD, Non-interlaced video-graphics, 100-Hz $\pm 1\%$ or 120-Hz $\pm 1\%$ source frame rates, a 3D display may be supported. Depending on the data entering the display controller, it affects how well the DMD operates [117].

5.1.1.1. Parallel Bus Interface

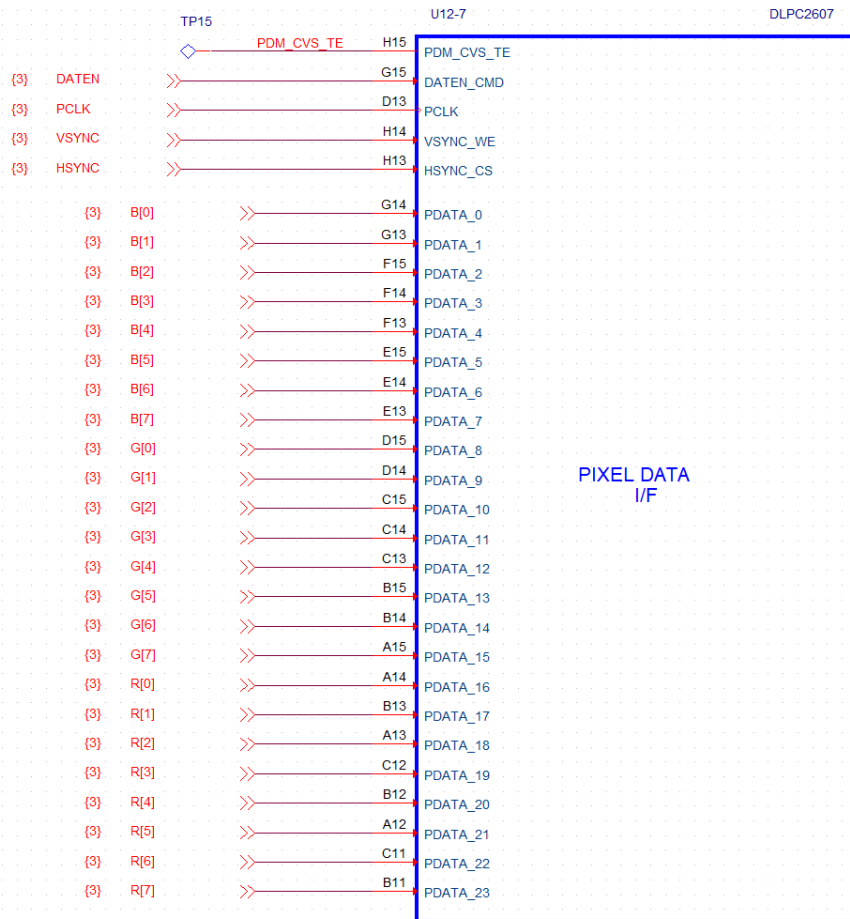

Figure 64 - DLPC2607 Data Interface

According to the figure above, the parallel bus interface complies with standard graphics interface protocol, which includes a vertical sync signal (VSYNC_WE), horizontal sync signal (HSYNC_CS), optional data valid signal (DATAEN_CMD), a 24-bit data bus (PDATA), and a pixel clock (PCLK). The user can program the polarity of both syncs and the active edge of the clock. The figure shows the relationship of these signals. The data valid signal (DATAEN_CMD) is optional in that the DLPC2607 device provides auto-framing parameters that can be programmed to define the data valid window based on pixel and line counting relative to the horizontal and vertical syncs.

The parallel bus interface supports six data transfer formats:

- 16-bit RGB565
- 18-bit RGB666
- 18-bit 4:4:4 YCrCb666
- 24-bit RGB888

- 24-bit 4:4:4 YCrCb888
- 16-bit 4:2:2 YCrCb

5.1.1.2. Serial Flash Interface

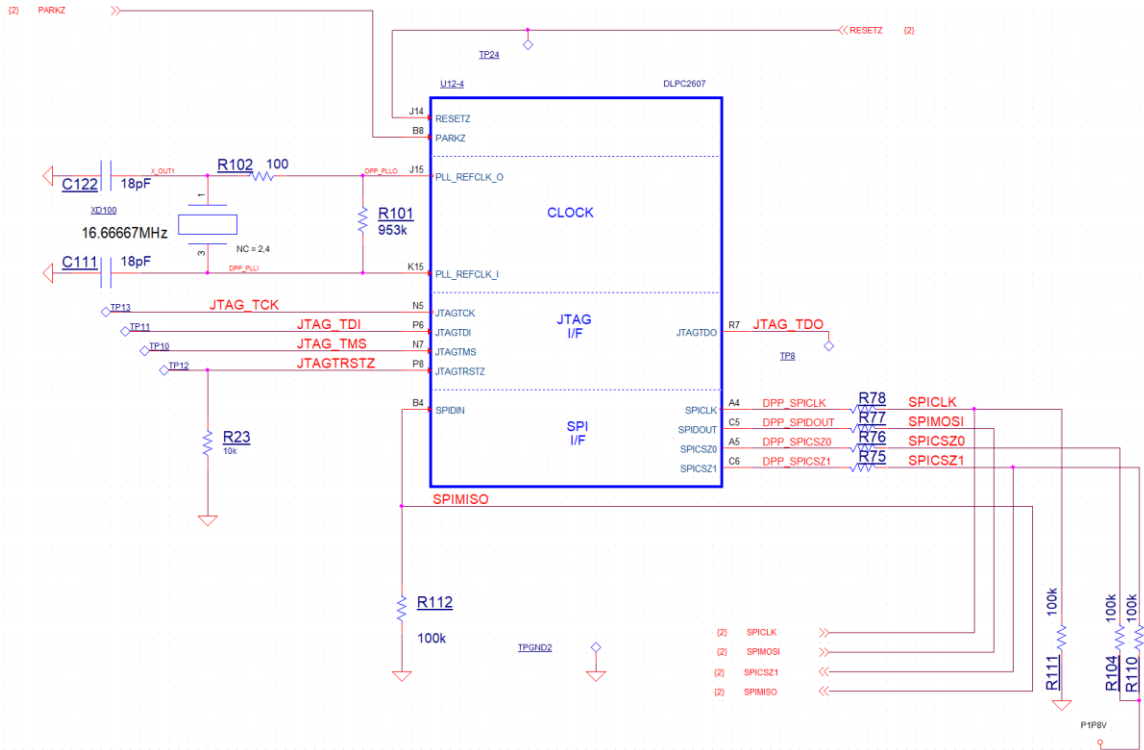

Figure 65 - DLPC2607 Serial Flash Interface

The DLPC2607 device uses an external SPI serial flash memory device for configuration support. The minimum required size depends on the desired minimum number of sequences, CMT tables, and splash options while the maximum supported is 16 MB. The DLPC2607 device does not have any specific page, block, or sector size requirements, except that programming with the I2C interface requires the use of page mode programming. The DLPC2607 device supports 1.8 V, 2.5 V, or 3.3 V serial flash devices. [118]

5.1.2. Power Management and Diode Driver IC

The DLPA1000 is the assigned PMIC / RGB LED driver for the DLP2000 Digital Micromirror Device (DMD) when used with a DLPC2607 digital controller. For the chipset to operate efficiently, it is required to use the DLPA1000.

The power management device has been designed for TI DLP Pico Projector systems and for embedded use. For projectors, the DLPA1000 has its own external power supply and operates on its own. It contains three switch-mode power supplies that power the DMD: the three rails are VOFS, VBIAS, and VRST. Once all three rails are powered, then the LED driver can be powered on.

The LED driver can supply up to 1 A per LED with the integrated high-current switches that sequentially select the red, green, blue LED. SPI is used to configure the setting of the currents for each LED. Some additional features are the generation of the system reset, power sequencing, input signals for sequentially selecting the active LED, IC self-protection, and an analog multiplexer and comparator to support A/D conversion of system parameters. [119]

Mode	Description
Off	This is the lowest-power mode of operation. All power functions are turned off, registers are reset to their default values and the IC does not respond to SPI commands. RESETZ and PWR_EN pins are pulled low. The IC will enter OFF mode whenever the PROJ_ON pin is pulled low
RESET	Logic core and registers are reset to default values, the IC does not respond to SPI commands, RESETZ and PWR_EN pins are pulled low, but the analog reference system is kept alive. The device enters RESET state when the input voltage drops below the UVLO threshold.
STANDBY	All power functions are turned off, but the IC does respond to the SPI interface. The device enters STANDBY mode when PROJ_ON pins is high, but DMD_EN bit is set to 0. Also, device enters STANDBY mode when a fault on the DMD regulator occurs or the temperature increases above thermal shutdown threshold (TSD).
ACTIVE1	The DMD supplies are powered up but LED power (VLED) and the STROBE DECODER are disabled. PROJ_ON pin must be high, DMD_EN bit must be set to 1, and VLED_EN bit set to 0.
ACTIVE2	DMD supplies, LED power and STROBE DECODER are enabled. PROJ_ON pin must be high and DMD_EN and VLED_EN bits must both be set to 1.

Table 11: Modes of Operation

5.1.3. DMD Interface

The control serial interface handles instructions that configure the DMD and control reset operation. DRC_BUS is the reset control serial bus, DRC_OEZ is the active low, output enable signal for internal reset driver circuitry, DRC_STROBE rising edge latches in the control signals, and SAC_BUS is the stepped address control serial bus. [120]

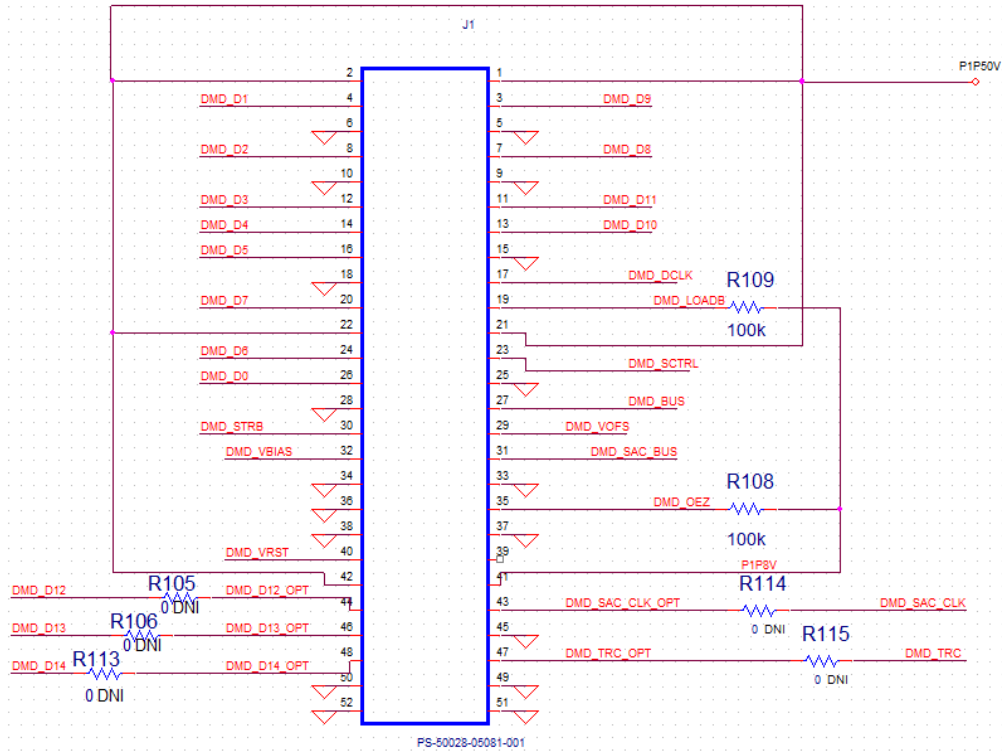

Figure 66 - DMD Flex Cable Connector.

5.1.4. Board Connectors

A powerful feature of the Raspberry Pi is the row of GPIO (general-purpose input/output) pins along the top edge of the board. To control the DLP system through a host processor, the selected host must possess the necessary GPIO pinouts to drive the inputs to the board. This can be accomplished using a customized video and I2C output driver.

Two 5V pins and two 3V3 pins are present on the board, as well as a number of ground pins (0V), which are unconfigurable. The remaining pins are all general purpose 3V3 pins, meaning outputs are set to 3V3 and inputs are 3V3-tolerant. For outputs, a GPIO pin can be set to high (3V3) or low (0V). For inputs, a GPIO pin can be read as high (3V3) or low (0V). This is made easier with the use of internal pull-up or pull-down resistors. Pins GPIO2 and GPIO3 have fixed pull-up resistors, but for other pins this can be configured in software.

As well as simple input and output devices, the GPIO pins can be used with a variety of alternative functions, some are available on all pins, others on specific pins.

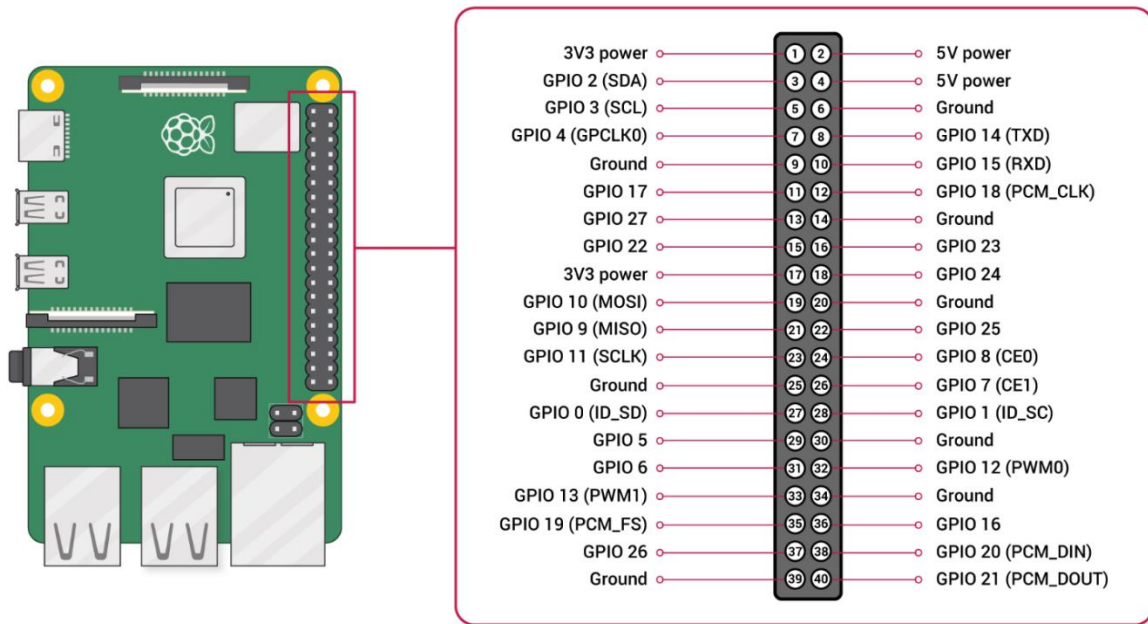

Figure 63 - Microcontroller-Board Interface Connectors for GPIO.

A Raspberry Pi HAT is an add-on board with an embedded EEPROM designed for a Raspberry Pi with a 40-pin header. The EEPROM includes any DT (Device Tree) overlay required to enable the board (or the name of an overlay to load from the filing system), and this overlay can also expose parameters. Once the system is set up properly, the Raspberry Pi communicates with the EEPROM on the Display Controller. This signals the Raspberry Pi to load the appropriate DT overlay to configure the GPIO ports on the host processor. Once the overlay is loaded, the host processor can interact with the board using parallel I/F video data (through RGB888).

5.2. Optical Engine Assembly

The optical engine will be separated into two main sub-assemblies: The illumination subassembly and the image projection subassembly. The illumination subassembly will contain three diodes for illumination, and two dichroic mirrors, the projection subassembly will contain the homogenizer, prism system, DMD, and projection optics for creating the image. Because of the complexity of each subsection, we have made the decision to purchase a DLP optical engine from Texas Instruments. The DLP 2000 LightCrafter™ Display Evaluation Module contains all the optics pre-assembled and ready for plug-and play. It is Raspberry Pi compatible and available for purchase.

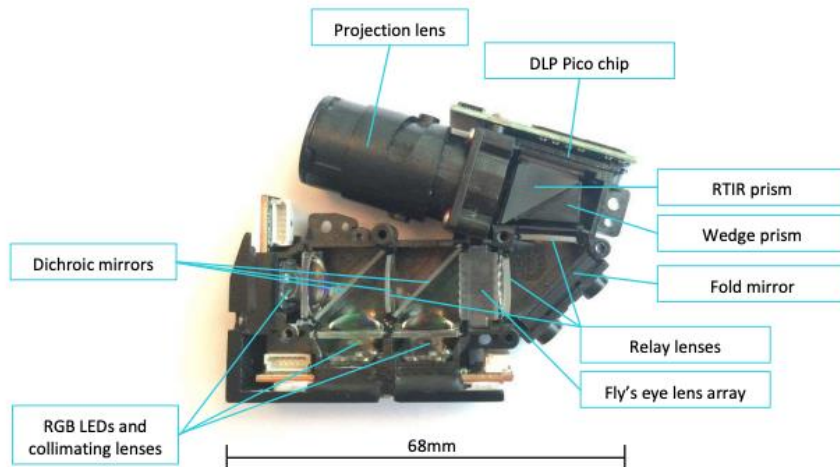

Figure 67 - Optical Components in an Example Pico Projection Optical Module taken from Texas Instruments [121].

This decision was decided entirely base on cost. This decision came at great cost to the ability of the device to meet our initial specifications, particularly in resolution and brightness. The EVM produces less than 50 Lumens, when our target was to be over 100 Lumens; and the DLP2000 DMD chipset only provides a resolution of 640x360 pixels, which is significantly below our “high resolution” target of 1080p. Although we cannot change the resolution without replacing the entire DMD, we can improve the brightness of the system by replacing the illumination subassembly of the DLP2000 with an optical system of our own design, with lenses hand crafted by ourselves.

AUDIOVISIBLE’s optical engine will feature the projection optics of the Texas Instruments DLP2000 Evaluation Module illuminated by an illumination system consisting of three monochromatic RGB diodes, being focused by monochromatic diffractive waveplate lenses (provided by BEAM Co.) and unified with dichroic mirrors. This light will be directed into the fly’s eye lens array homogenizer provided by the DLP2000 EVM, where Texas Instrument’s optical engine will take care of the rest.

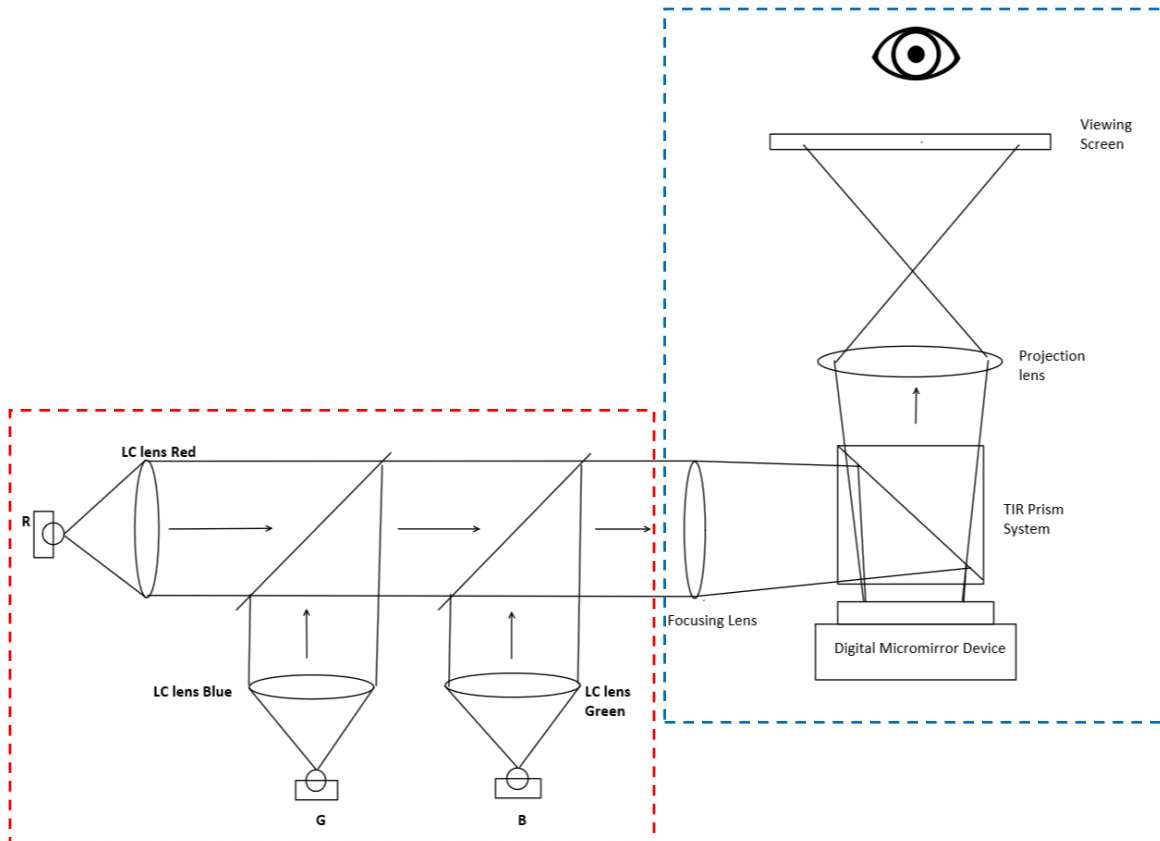

Figure 68 - Finalized Optical Setup Schematic. Pictured: Planned Illumination Setup (boxed in red) and simplified projection setup (boxed in blue)

5.2.1. Illumination Diodes

The system will be illuminated by three laser diodes operating at wavelengths of 450nm, 520nm, and 648nm. Each laser gives an output between 80 and 100mW of optical power. The light from each diode will immediately be incident upon film containing a linear polarizer followed by a quarter-wave plate to achieve circular polarization. The circular polarizing film will be right up against the diffractive waveplate lenses. The diodes will be driven by separate voltage regulators, as each diode has a completely different voltage requirement.

	Red	Green	Blue
Wavelength (nm)	648	520	450
Operating voltage (V)	2.4	6.5	5.1
Max voltage (V)	3	7.5	6
Threshold Current (mA)	65	65	22
Max Current (mA)	150	90	110
Max output power (mW)	100	85	80

Table 13 - Operating specifications of the laser diodes used for illumination of this project

When the light from the lasers passes through the linear polarizer for the first time, it will lose half of its intensity immediately. This means that each laser will have to be of sufficient power to compensate for this effect. It is because of this that I have

chosen to have such high-intensity lasers for our setup. I expect from rough calculations that we will have a total intensity up to but no more than 130mW of optical power incident upon the DMD in the assembly.

5.2.2. Collimating lenses

As mentioned in section 5.2.1, the light from the diodes will immediately be converted to right-hand circular polarization so that it can be collimated by the liquid crystal diffractive waveplate lenses. The handedness of the circular polarization is critical. If the light is the wrong polarization when it hits the lens, it will not focus, but defocus by the exact same power. The lenses are each specifically coated for their respective laser wavelengths and will have a focal length of about 200mm. they will collimate their beams to a diameter slightly exceeding 5mm.

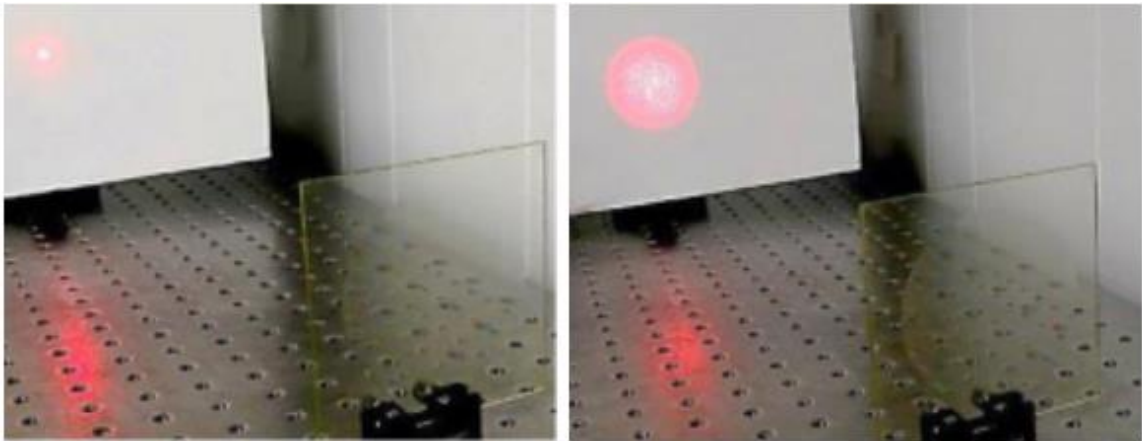

Figure 69 - Example of a LC diffractive lens. Both images are of the same laser and the same lens, but with different circular polarizations running through. It is easy, but critical to get the proper polarization passing through the system [51].

5.2.3. Dichroic mirrors and relay lens

The last part of the illumination system we'll be building is how we direct the light into the projection subassembly. Once the light has been polarized and collimated, it will be directed using the dichroic mirrors we salvaged from the EVM itself. The light will be reflected off of the mirrors directly into the relay lens that is still attached to the DLP Projector subassembly.

5.3. Audio Output Assembly

An amplifier in signal analysis is defined by an input that has an output of an increased amplitude in the signal, allowing for magnification of volume. The output produces a Gain from how large the signal accrued. Mathematically, Gain is output/input. There are two types of Gains, Voltage and Current, and there is Power Gain for how much power has been amplified in the system [122].

An example of an amplifier is a transistor. A transistor amplifier has three types, common emitter, common collector, and common base. A common emitter is where the voltage is connected to the common and the base, thus causing an increased magnitude in voltage [123]. For audio signals, this is the most desirable

and the one AUDIOVISIBLE will be implemented with for amplification to the speaker.

In terms of audio, each frequency of sound must be amplified the same amount so there are not any distortions to the wave nor the quality. Distortion occurs when the waveforms are clipped, causing harmonic distortion, or when different frequencies mix and clash to form intermodulation distortion. Also, when the beat or signal is altering too quickly, thus having the system not be able to process at that pace, this is transient distortion [124]. To prevent these types of distortions, audio regulators and equalizers can be implemented. Also, installing the appropriate speaker will prevent any damage to the physical product. With higher-quality speakers, the output will be of a better standard and not have clipped waveforms [125]. Commercial amplifiers allow for linear amplification across the entire waveform and stay within the realms that the sound system allows. With enough power, quality will not be an issue.

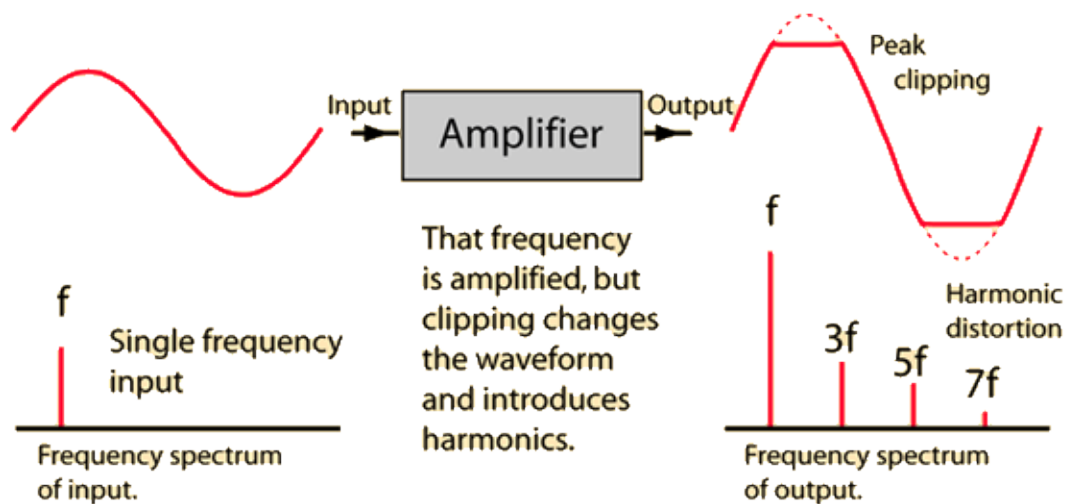

Figure 70: Harmonic Distortion is when the waveforms are clipped, having the sound be off tone

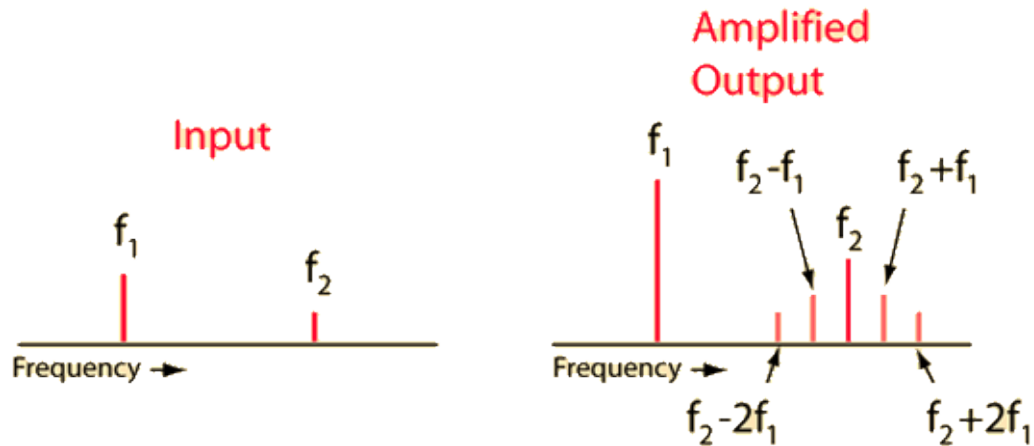

Figure 71: Intermodulation distortion is when sounds combine to produce an unexpected output of clashing

5.4. Power Input Assembly

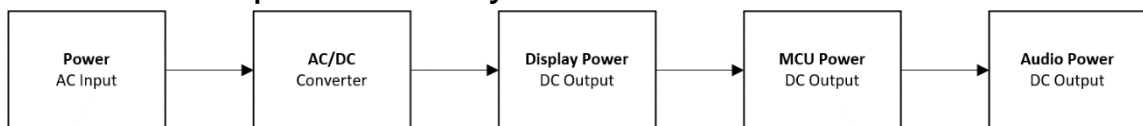

Figure 72 - Power Input Block Diagram.

The device will be powered up by applying an external DC ITE power supply. The specifications on the recommended power supply is 5V-DC, 3A maximum output current that is compatible with the J2 connector. Texas Instrument recommends the TE20A0503F01 Desktop Wall Adapter or equivalent, because the DC power supply jack has 2.5mm inner diameter and 5.5 outer diameter. This adapter is a standard model that includes a 2.5 x 5.5 x 9.5mm straight barrel type connector (center positive), commonly used for an Class 1 Desktop. [126]

Similar to the figure above, the power supply will be designed in series. First, the wall mount adapter will power up the display device. Second, the host processor will be connected to the J3 header on the display board, with a power and ground already supplied. Lastly, the audio speaker will be connected to the processor, and it will receive just enough voltage to function efficiently. [127]

5.5. Microcontroller Assembly

Also referred throughout this paper as MCU, Host Controller, or Single Board Computer, this assembly oversees the audio processing and generation of the video output.

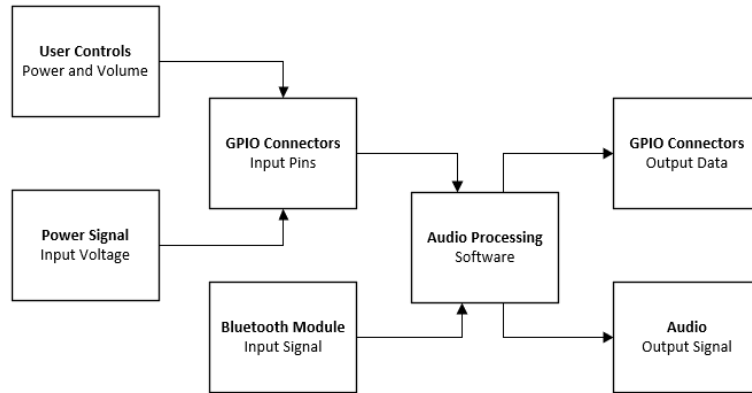

Figure 73 - Microcontroller Block Diagram.

This component requires no hardware design on its own, however some design is needed for the user controls and input power. The power is covered in section 5.4. Power Input Assembly, while the user controls are so simple, they will be probably connected directly to the GPIO connections that are left available.

5.6. Software Design

In this section we will discuss the software development plan for enabling the data reception, conversion, analysis and transmission necessary for this project. AUDIOVISIBLE must be able to analyze and break down analog signals and turn that information into instructions for the operation of the optical and display subassemblies. By capitalizing on the built-in functionality from the Raspberry Pi OS to have a user interface, the software can focus its concerns in just processing the audio and using regular methods to display to the screen.

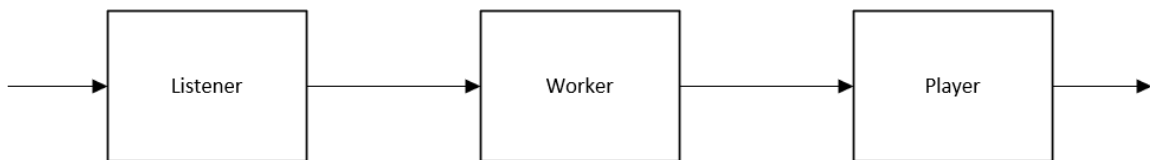

Figure 74 - Software Functional Diagram.

An important concept to understand is that of an Epic. In Agile software development, an “epic” is a body of work that can be broken down into specific tasks (called user stories) based on the needs/requests of customers or end users [128]. For AUDIOVISIBLE, three Epics are required to be completed, and are be elaborated below:

5.6.1. The Listener

The listener epic will contain the logic needed to capture the input stream. This is the first part of the application that is available, and plays a crucial role communicating with the casting device.

5.6.1.1. The Loop

The action of listening requires a constant cycle of waiting. This is a very basic action, that is programmatically trivial, however crucial for the smooth performance

of the program. The first condition for this loop to exist, is to have a device to listen from. For a Bluetooth input, an available and active Bluetooth device must be enabled and receiving data from another Bluetooth device. For as long as this is present, the loop can continue to listen.

5.6.1.2. Get the Stream

Another aspect of any listening action is being able to identify and understand the incoming information. In the case of Bluetooth, various profiles or protocols can be expected, but A2DP is the stream the listener is looking for. The listener should get chunks or batches of data from a stream and pass it over to the worker for processing.

5.6.2. The Worker

The worker epic contains a set of functions that determine key attributes of the system. Although the name worker tacitly implies that this epic does the work, it does not do all the work.

5.6.2.1. Get the Mode

For the prototype, the mode would be set by a global variable or an entry on a configure file, however, in principle, the software should be built to allow different display modes, as desired by the user.

5.6.2.2. Get the Frequency

This function should return the frequency of a given audio input. Here is where some math libraries will be applied, and some tough decisions will be made.

5.6.2.3. Get the Color

This function should return a color, given a frequency. The logic should use the Sonochromatic scale as a lookup table to quickly return the hexadecimal value of RGB.

5.6.2.4. Get the Beat

This function should return the beat of a given audio input. This might require keeping a small historical data structure to know when a beat occurs, by comparing the previous volume levels with the one in the input.

5.6.3. The Player

This epic encapsulates both the video and audio outputs. The reason to group them like this, is due to the synchronization required between them.

5.6.3.1. Render on Screen

Due to the several versions that should be available when the prototype is completed, to render on the screen, separate functions will be created, one per display “mode”. This approach allows the “player” methods to draw on the screen depending on a parameter. The parameter should be called “DisplayMode” and its values should include:

- WAVO for the waveform visualization.
- EQUILIZO for the equalizer visualization.

- SHAPERO for the concentric shapes visualization.
- PSYCHO for the psychedelic visualizations.
- NERUALIS for the deep dream visualization.

5.6.3.2. Audio Output

This method sends the chunk of audio to the audio output. The greater complexity will be in keeping the audio at par with the video. Some tolerance will be added if the disparity is unnoticeable.

6.0. Project Prototype Construction and Coding

The purpose of prototyping is to create a real-life model of the system to be tested upon for functionality, reliability and optimization. All tests would be done on the hardware with multimeters, oscilloscopes, and breadboards. The software will be tested with unit testing, integration testing and interface testing. The results of each test will allow the team to make decisions that will bring this project to a successful end.

6.1. PCB Vendor and Assembly

When deciding on a PCB manufacturer, there are multiple factors that must be in consideration since the PCB is one of the main components of the device. A manufacturer's quality determines if the device will operate. Proper usages of various elements, such as copper, are volatile to the PCB.

6.1.1. PCB Unlimited

In 2008, PCB Unlimited, sister company of Stencils Unlimited, developed a shopping cart where designers and engineers could easily quote and order anything from simple low-cost quick turn prototype PCBs and prototype SMT stencils to very sophisticated pick and place and selective soldering machines. The manufacturer currently based in Portland, Oregon. The location may not be local but there is an opportunity to allow the PCBs to be shipped in a range of 1-5 business days. [129]

6.1.2. Easy PCB USA

EasyPCB offers value priced, high quality PCBs manufactured in the USA. Their shipping is delivered within 3 days or less with free shipping. They require one board to be purchased at a minimum on 2- or 4-layer boards. With their boards being automated and processed by advanced algorithms for efficiency, it allows for cheap and quick PCBs. EasyPCB is known for following and meeting the IPC-A-600 Class 2 specifications to assure quality PCBs. A Gerber file is accepted upon import and upload for PCB requests. For two layers, it will cost \$25+ since it is \$1 per square inch of the board. For four-layer boards, it will cost \$60+ since it is \$2 per square inch of the board [130].

6.1.3. Advanced Circuits

Since 1989, Advanced Circuits (4PCB) has been the leading the PCB industry as a quick turn manufacturer specializing in both small quantity PCBs and production quantities. Advanced Circuits operates divisions in Aurora, CO, Chandler, AZ, and Maple Grove, MN and is ranked among the 3rd largest circuit board fabricators in North America. They serve diverse industries that depend on their high-quality printed circuit boards, delivered on-time. Their customers rely on them for the PCBs they need for military, aerospace, defense, medical and many more critical applications. Advanced Circuits is one of the few PCB suppliers that can manufacture for DOD Contracts in the United States. Advanced Circuits is well-known for their reliability, excellent customer service, free exclusive services, plus their early and on-time shipping record. They're also known for their Same Day

Turn, Weekend Wonders, scheduled out deliveries, and no minimum quantity. With their same day and weekend turns, they can help their customers with all their expedited printed circuit board requirements. With over 10,000 active customers, Advanced Circuits is the industry's preferred choice for all PCB and PCB assembly needs. [131]

6.1.4. Sunstone Circuits

Sunstone Circuits is the established leader in providing innovative and reliable printed circuit board (PCB) solutions for the electronic design industry. With 48 years of experience in delivering USA made high quality, on-time PCB prototypes, Sunstone Circuits is committed to improving the prototyping through production processes for the design engineer from quote to delivery. With Around the Clock support, Sunstone Circuits provides unparalleled customer service and leads the industry with a real On-Time Guarantee that is the first of its kind. We're proud to manufacture high-quality products USA products, and provide a safe and prosperous workplace for our employees. [132]

6.1.5 OSHPark

OSHPark produces high quality bare printed circuit boards, and they focus on the needs of prototyping and light production. Their services offer purple solder mask over bare copper (SMOBC) and an Electroless Nickel Immersion Gold (ENIG) finish. That are suitable for a lead-free reflow process and are RoHS compliant.

The prices for producing PCBs from OSH Park are as follows:

1. The Standard 2 Layer Order - \$5 per square inch
 - a. Includes three copies of the design; order is in multiples of three
 - b. Ships within 12 calendar days
 - c. Board Thickness: 63mill (1.6mm)
 - d. Copper Weight: 1 oz
2. The Standard 4 Layer Order - \$10 per square inch
 - a. Includes three copies of the design; order is in multiples of three
 - b. Ships within 2-3 Weeks
 - c. Board Thickness: 63mill (1.6mm)
 - d. Copper Weight: 1 oz (outer), 0.5 oz (inner)

OSH Park does give the option for Super Swift Service for the Standard 2 Layer boards at a price for \$89 extra. This would have the boards shipped within 5 business days opposed to the standard 12 calendar days. Otherwise, ground shipping cost would be free unless opted for sooner delivery time at expedient rates. [133]

Specifications:

- All 2-layer boards are FR4 170Tg/290Td which are suitable for lead-free processes and temperature
- 4 Layer boards are now FR408 (180Tg)
- They have ENIG (gold) finish for superior solderability and environmental resistance

- They're 1.6mm thick (0.063 inches) with 1-ounce copper on both sides.
- For four-layer boards, the internal copper is 0.5 ounce
- The minimum specs for 2-layer orders are 6 mil traces with 6 mil spacing, and 13 mil drills with 7 mil annular rings
- The minimum specs for 4-layer orders are 5 mil traces with 5 mil spacing, and 10 mil drills with 4 mil annular rings
- Internal cutouts are allowed and supported. Draw them on your board outline layer
- Plated slots aren't supported

Based on the schematics that we designed, we will need to solder the electrical components for the assembly to be complete. Some members of the team will use their personal equipment to add the components to the board because they have personal experience with soldering from class projects and internship opportunities.

6.1.6 Conclusion

Based on the pricing and shipping options, OSHPark seems to be the best option available to the team's budget. The other vendor options may have more certifications and years of experience, but since our PCB is basically considered "barebones", we prefer a low-cost board for the completion of this project. The special thing about OSHPark is that their website provides a clear description of how the cost is provided. This will allow us as a team to carefully design the necessities of the project, while ensuring the price remains low for the PCB.

Feature	PCB Unlimited	Easy PCB USA	Advanced Circuits	Sunstone Circuits	OSH Park
Price	\$50	\$25.00+ \$1/in ²	\$33 each	\$25 per square inch	\$5 per square inch
Website	www.pcbunlimited.com	easypcbusa.com	www.4pcb.com	www.sunstone.com	oshpark.com
Certifications	ISO and UL Certified	IPC-6012 Class II	IPC-6012 Class II	RoHS-compliant, ISO, UL Certified, IPC-6012 Class II	RoHS-compliant
Guarantees		Free Replacement	50% student discount	20% student discount	Free ground shipping

Table 14 - PCB Vendor Comparison.

6.2. Single Board Computer

AUDIOVISIBLE implements the latest available version of the popular Raspberry Pi single board computers, the Raspberry Pi 4, model B+. This device is very powerful, and it doesn't require any hardware modifications. It does require some extensive configuration. This section will explore this configuration from a development prototype perspective; however, the final version should follow similar steps, albeit maybe a few less.

6.2.1. Configuration

In order to configure the Raspberry Pi 4 to be the audio processing assembly of AUDIOVISIBLE, the following steps must be performed:

1. Install the Raspberry Imager, available at the official Raspberry website.
2. Select Raspberry Pi OS 32-bit (previously called Raspbian).
3. Install OS into the MicroSD card and insert into the Raspberry Pi 4.
4. User is pi and password is raspberry, however the first time, a visual interface greets the user and allows for some basic configuration.
5. Configure the internet connection. For wireless internet connection, it is possible to specify and save the network credentials in the following document:

```
$ sudo nano /etc/wpa_supplicant/wpa_supplicant.conf
```
6. Change the password to “audiovisible”
7. Change the hostname to be something uniquely identifiable.
8. Upgrade system:

```
$ sudo apt upgrade
```
9. Install the Bluetooth packages:

```
$ sudo apt install bluetooth pi-bluetooth bluez blueman
```
10. Install linear algebra libraries:

```
$ sudo apt-get install libatlas-dase-dev
```
11. Go to Bluetooth adapters, and change the Visibility Setting to “Temporarily visible” and Friendly Name to “AUDIOVISIBLE”
12. Restart the system, and confirm that the Bluetooth is working:

```
$ bluetoothctl list
```
13. Install the needed Python libraries:

```
$ pip3 install pybluez  
$ pip3 install matplotlib  
$ pip3 install scipy
```

6.3. Website

The website will be utilizing a simple HTML framework with CSS for styling. It will be completely static and hosted by the UCF server. Professional photographs and a short biography on the team, such as major and graduation year, will be present. A video showcasing AUDIOVISIBLE and how it works will be present for viewers to watch. Sample photos and videos will be available as well. The website will have enough information to show that the product operations as required, highlight how the team effort came to be, and the story behind the device.

6.4. Final Coding Plan

This section will cover the intricacies of the software development process, and the main coding epics scheduled to complete.

At point in time in 2020, tools and platforms provided by the cloud can bring the source code of the software developed by the programmer straight to the prototype in a single step. This is called a CI/CD Pipeline. The idea currently widely used across industries to speed up the software development process and comply with

Lean development principles, where “working software” is king. These pipelines are not different from an industrial pipeline where a product goes through stages to ensure an optimal final product. DevOps, or Development Operations, is as important as the developed software itself, because it multiplies the effectivity of the developer, simplifies the job of the manager, and ensures that good practices are maintained throughout. To apply Lean principles to DevOps, it is important to follow the Three Ways [134]:

1. The principles of Flow, which accelerate the delivery of work from Development to the AUDIOVISIBLE device.
2. The principles of Feedback, which enable us to create ever safer systems of work where issues in the system are promptly identified and resolved.
3. The principles of Continual Learning and Experimentation foster a high-trust culture and a scientific approach to organizational improvement risk-taking as part of our daily work.

6.4.1. Development Life Cycle

Nowadays, the software engineer understands that software development is not an isolated process, and careful consideration to the overall system is always present. Higher and higher levels of abstractions sometimes mean repeated computations, and inefficient code, and at times it might be required to go to a lower level language to accomplish a function optimally. At times, when switching from one language to the other, the development cycle might change slightly, but it should stay about the same throughout, except some of the automations and improvements that DevOps can complement it with.

The software development cycle for a project that uses Python and Azure DevOps as its source code repository, allows the configuration of automated integration, testing, deployment and feedback.

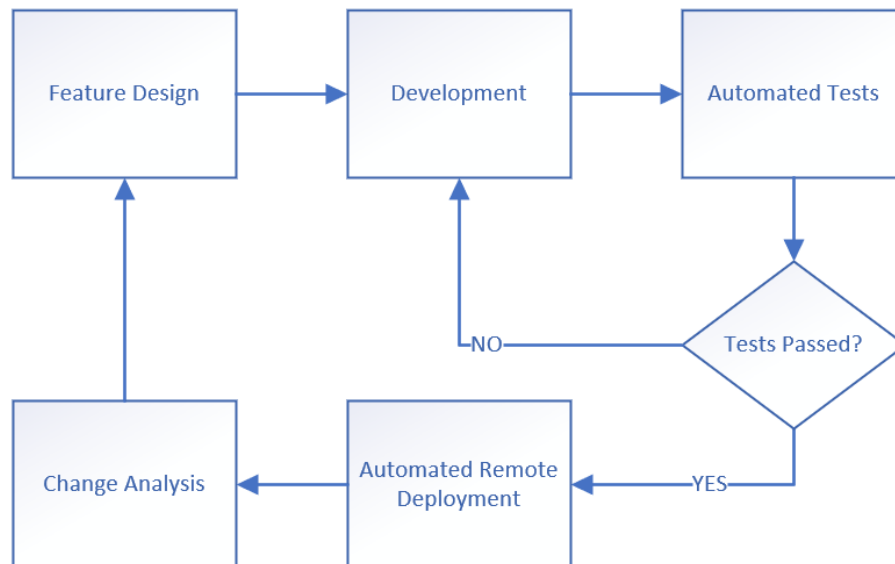

Figure 75 - Software Development Cycle

6.4.2. Continuous Integration

In software engineering, continuous integration (CI) is the practice of merging all development work done by various engineers and programmers into a shared “master” repository several times a day. However, merging is just part of the process, because one thing is having all the code together, and another is making sure it works properly. As a minimum, even if the merge is successful, the software compilation needs to be successful as well. On top of that, it is possible to add a set of automations that will test/check the code for bugs or issues.

6.4.2.1. Git Merge

When using the free and open source distributed version control system, git, it is important to use and understand its principles accurately. Before the software engineer starts to work, it is mandatory that she or he “pull” the latest copy of the source code. Then, having the latest copy of the repository on the local system, the engineer can only work on a single task, modifying as little files are necessary to complete the requirement. Once the task is completed and builds successfully in the engineer’s local system, another pull of the changes must be done, in case another engineer has made changes to the repository. Once the latest version is stored locally, it is time to merge the changes into master. If changes are merged successfully and conflicts are resolved, then it is time to “push” the changes to the online repository.

The online private repository can be found here:

https://dev.azure.com/ucf2020/_git/AUDIOVISIBLE

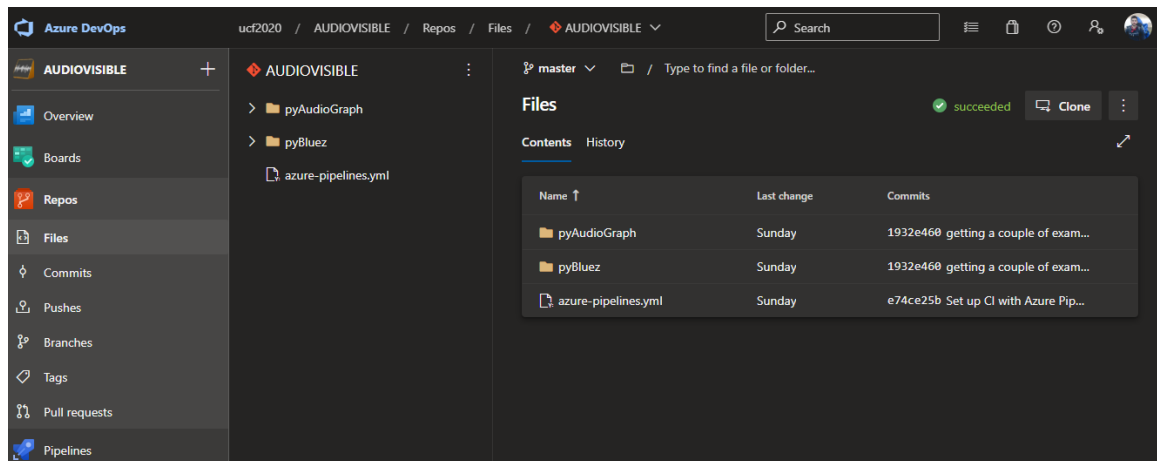

Figure 76 - Screenshot of the Online Source Repository

6.4.2.2. Automatic Build

Once the new code developed by the software engineer builds correctly in the local system, and it is pushed into the main online repository, then another build is performed, this time automatically. In Azure DevOps, the AUDIOVISIBLE engineer receives immediate feedback from the online repository because the Build Pipeline will not only build the system, but also make sure that the build works for the destination system, and that all requirements are met for deployment. In order to

implement CI Pipeline in Azure DevOps, it is necessary to have a .yml file, in which very specific instructions are configured to automate the build process.

6.4.2.3. Unit Testing

In software engineering, unit testing is a software testing method by which individual units of source code are tested to determine whether they are fit for use. Ideally, this testing can be configured to be triggered after a successful project build, and they would execute completely automatically, without any human interaction. If all the tests are completed successfully, then the instance of the building pipeline would be considered successful. For every single test that fails, the engineer would receive the exact details of the failure, only minutes after committing his/her changes to the online repository.

6.4.3. Continuous Deployment

After the successful completion of the Continuous Integration pipeline, the continuous deployment pipeline will be triggered automatically. The CD process consists of a discrete set of steps that takes the built project from the repository and deploys it to specific systems. During the development of the prototype, the release would be direct to all Raspberry Pis available online. Continuous deployment to the microcontrollers will not be configured, and manual deployments will be necessary to the specific subassembly.

6.4.3.1. Deployment Groups

A deployment group is a set of devices registered to receive the software build. By configuring a deployment group, the engineer no longer needs to perform a lengthy deployment process where he or she would need to repeat the same steps, in each device, just to see if it works. Challenges arise when a deployment from one engineer conflicts or interferes with the changes or testing of another. However, as long as all engineers involved in the project understand this, confusion should not arise because the change and interference will be expected and dealt with.

A deployment group in Azure DevOps contains two sections: Details and Targets.

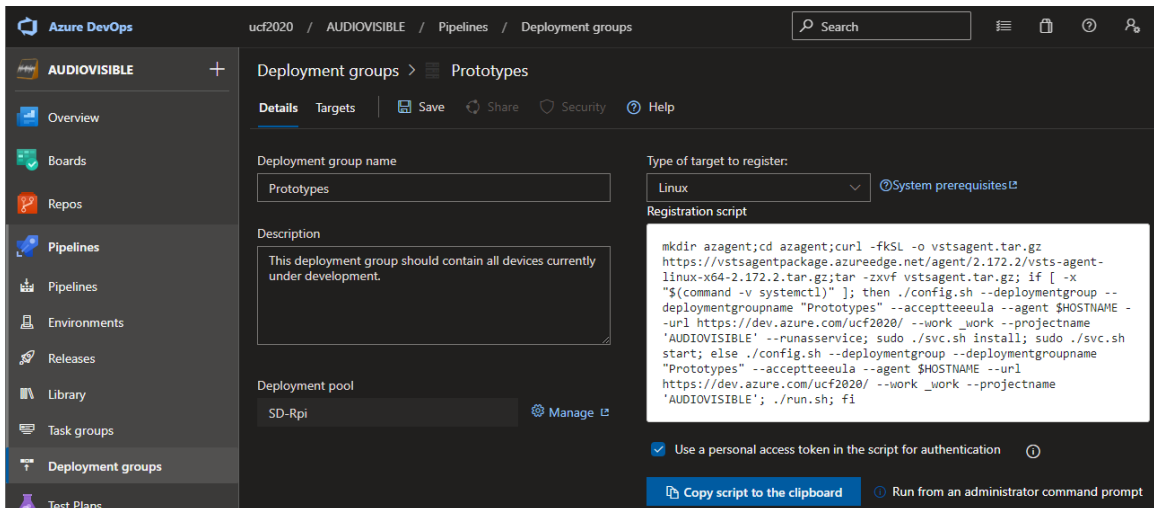

Figure 77 - Deployment Group Details.

Under the Details section, the main characteristics of the group can be found. The main reason for the engineer to pay attention to this section, is that it contains the Registration Script. This script is necessary to run on the target device that is supposed to receive the software build automatically. This script comes with two caveats. First, it can't be run as administrator on a Linux environment. Second, is that the package name for a Raspberry Pi is different from the one automatically generated by Azure, and it is necessary that the engineer changes three letters from *vsts-agent-linux-x64-2.172.2.tar.gz* to *vsts-agent-linux-ARM-2.172.2.tar.gz*.

Once the script completes successfully, the device should appear under the Targets section. This section allows the engineer to not only view the devices available as targets, but also to add tags, which will help the configuration of the release pipeline.

6.4.3.2. Release Stages

The steps taken from the moment the code finishes successful compilation, to the moment it reaches the final prototype, can be defined as stages. In the case of AUDIOVISIBLE, there is little complexity during prototyping, and there are only two stages required: test and production. However, in an effort to show demonstrate clearly each release stage, “test” is divided in three, one per engineer’s device. After the continuous integration pipeline completes and generates a new artifact, this artifact will be sent in parallel for deployment to the three devices. After the successful deployment of the compiled code to any available device, the pipeline will automatically deploy it to production, which is the final and most complete prototype.

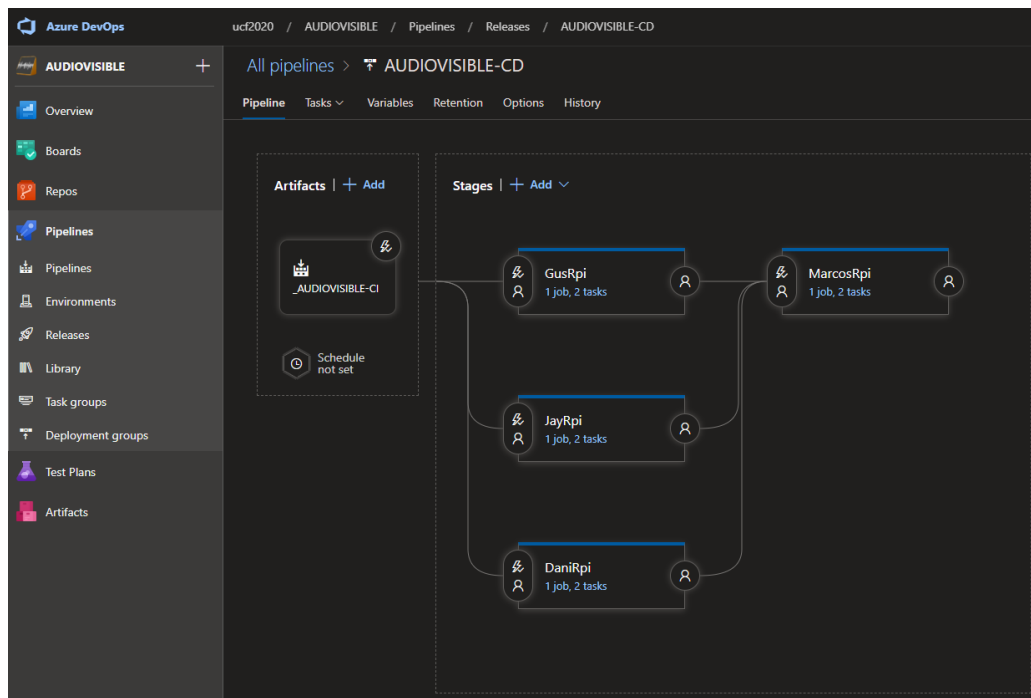

Figure 78 - Screenshot of the CD pipeline instance of the second automated deployment to a Raspberry Pi 4

Inside of each deployment stage, there is currently one job with two tasks. The job is a simple and generic deployment group job, where the configuration that specifies the exact device to be deployed to is defined. Then, within this deployment group, two straight forward tasks are queued: the copy of the compiled project over the internet to the device, and the execution of a bash script. The idea here is to bring the code to the device and place it in a particular directory. Once downloaded, a bash script can be run to restart the application or the whole device, and therefore make the latest version of the software automatically run. The whole process, from pushing the changes to the master branch of the repository, until the program is running in the end devices, should take less than 5 minutes. This short lead time is the key to unlock a team's performance. This approach should uncover bugs and issues almost immediately, forcing the engineers to deal with them in order to continue progressing in the project's development.

6.4.4. Software Versions

The software in AUDIOVISIBLE has a simple architecture, however, after extensive research, it is a challenging endeavor that can get very complex if not properly planned. Due to this reason, the software has been broken into different versions, each version building on the previous, hoping to deliver a working version faster, and ensuring that by the final deadline, the software is as rich and powerful as possible.

6.4.4.1. Version 1 – Waveform Simulation

In order to complete this first version, the core functions of the system must be developed, tested and implemented. There are three core requirements for this version:

6.4.4.1.1. Capture the Bluetooth input

The Raspberry Pi 4 Model B+, comes with Bluetooth integrated, and the idea here is that the software needs to capture the Advanced Audio Distribution Profile (A2DP) of the input Bluetooth signal.

6.4.4.1.2. Method to output the audio signal through the jack and GPIO pins

The Raspberry Pi also comes with an audio jack output. However, this might not be enough to drive the speakers. The requirement here is the ability to output the audio via the 3.5mm earphone jack, or through the available GPIO pins.

6.4.4.1.3. Show a waveform on the screen

On the screen, a waveform representation of the screen should be seen. It should look something like this:

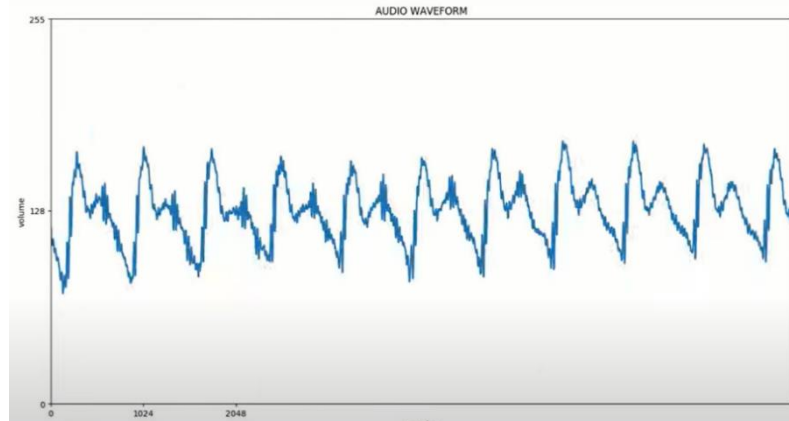

Figure 79 - Output example using PyAudio and Matplotlib libraries with input from microphone.

6.4.4.1.4. [Optional] Instead of a waveform, show an equalizer view

Create the visualization functionality in a way that depending on a parameter, the visualization can change from waveform to equalizer.

6.4.4.2. Version 2 – Pitch and Color

In this version, the requirement is to get make the background color of the screen to change by using the pitch and corresponding color from the sonochromatic scale.

6.4.4.2.1. Identify the pitch

Using Python's music libraries, create a method that can analyze the input signal and determine the frequency from any signal at any point.

6.4.4.2.2. Assign the correct color

Using Harbisson's Sonochromatic scale, determine what color to assign the background, based on the input frequency. This method should use something like the following data table to look up the values for Red, Green and Blue.

Frequency	Red	Green	Blue	Hex
349.2280	221	82	46	dd522e
349.9011	222	83	46	de532e
350.5750	222	84	46	de542e
351.2500	222	84	47	de542f
351.9280	223	85	47	df552f
352.6060	222	86	47	de562f
353.2850	222	87	48	de5730
353.9660	223	88	48	df5830
354.6480	223	90	48	df5a30
355.3320	223	93	50	df5d32
356.0170	223	95	51	df5f33
356.7030	224	96	52	e06034

Table 15 – Excerpt from Frequency RGB assignment based on Harbisson's Sonochromatic Scale.

6.4.5. Stretch Goals

With the second version of the software completed successfully and implemented on the device, the opportunity for a more complex rendering of the music input is possible. This section explores the possible next iterations.

6.4.5.1. Version 3 – Concentric Shapes

Introducing a new display configuration, this version would include a way of drawing shapes on the output screen, at the pace of the beat, keeping some of the waveform as distortions on the lines that outline the shapes. The image would appear first in the middle of the screen and increase its size while keeping its center the same.

6.4.5.1.1. Identify the beat

Create a function that identifies the occurrence of a beat.

6.4.5.1.2. New display method for shapes

Create a new display method that would generate a new shape at every beat. This shape should be generated using a simple mathematical formula and it can be in 2D or 3D, as long as no significant delay is added to the audio processing.

6.4.5.2. Version 4 – Random Psychedelic Art

The only two specific requirements specified in this section is that of generating these artistic images at a pace with the original marketing requirements, and to use the input from the audio signal to drive it.

6.4.5.3. Version 5 – Neural Networks

Aside from fulfilling the original project requirements and constraints, this section is completely in the hands of the engineer to explore. There is the possibility of needing different hardware to accomplish this, however, even if that was not the case, most likely a completely different architecture would be needed, where the whole music file would need to be run through the neural network, and not just the Bluetooth input. If such was the scenario, a new iteration on AUDIOVISIBLE might be required, reusing most of the existing technology and building on the previous development completed in the first prototype.

7.0. Project Prototype Testing Plan

Once we have decided what parts we need, they need to be ordered and tested. In this section we will identify which parts need to be tested, what performance we expect them to show, and if they meet expectations. We will also discuss which parts were unable to be tested due to time constraints, shipping delays or otherwise unavoidable issues caused by extraneous circumstances.

7.1. Hardware Test Environment and Breadboard

Due to constraints imposed upon us by the unprecedented COVID-19 pandemic. Unfortunately, we are completely unable to access the senior design labs on campus, so the testing environment for each piece of hardware will vary depending on the subassembly, and on who is responsible for it. Furthermore, since individual pixels are written at speeds in excess of 23MHz, **we will not be using a breadboard to test this project.** Due to breadboard capacitance at these frequencies, cross talk between the parallel color bus will be significant and very likely to cause problems. For testing, all connections will be as direct as possible.

7.2. Hardware-Specific Testing

Every piece of hardware in this project has its own performance expectations to meet. Some parts will need to be tested directly using a breadboard, while others more-so only require a visual inspection. In this section we will discuss those tests/inspections and how the devices performed accordingly.

7.2.1. Speaker

The speaker testing will consist on performing a set steps to confirm the correct functionality of each speaker.

7.2.1.1. Visual Inspection

Carefully the membrane is inspected for any ruptures and signs of damage. Once that is completed, very gently and using hand or fingers, depending on the size of the speaker, inspect the membrane trying to locate any imperfections, holes or a punctured part.

7.2.1.2. Multimeter

First, insert the standard multimeter test leads. Due to the small size of the speakers, protective caps should be placed on the test probes to prevent false readings due to high possibility of accidentally touching the probes in small space.

Checking the back side of the speaker to confirm its impedance, which is usually printed on the side of the metallic box that contains the wiring, the value of impedance should be around 8 ohms. It is worth noting that some homemade speakers can have impedances of 2 or 4 ohms, but the lower the impedance, the higher stress will be exerted on the speaker.

1. Set the multimeter on the lowest impedance setting.
2. Place the probes where the wires were soldered, according to poles.
3. If the multimeter is showing any value besides lowest ones, like zero, the speaker passed testing.

7.2.2. DLP2000 Evaluation Module

The testing for the EVM consists of a visual inspection and an operational test to see that the device turns on and can illuminate. When unboxed, the EVM seemed to be in good shape, with the optical module covered on all sides. We need to ensure that the covers protecting the engine are able to be removed so that we may make modifications.

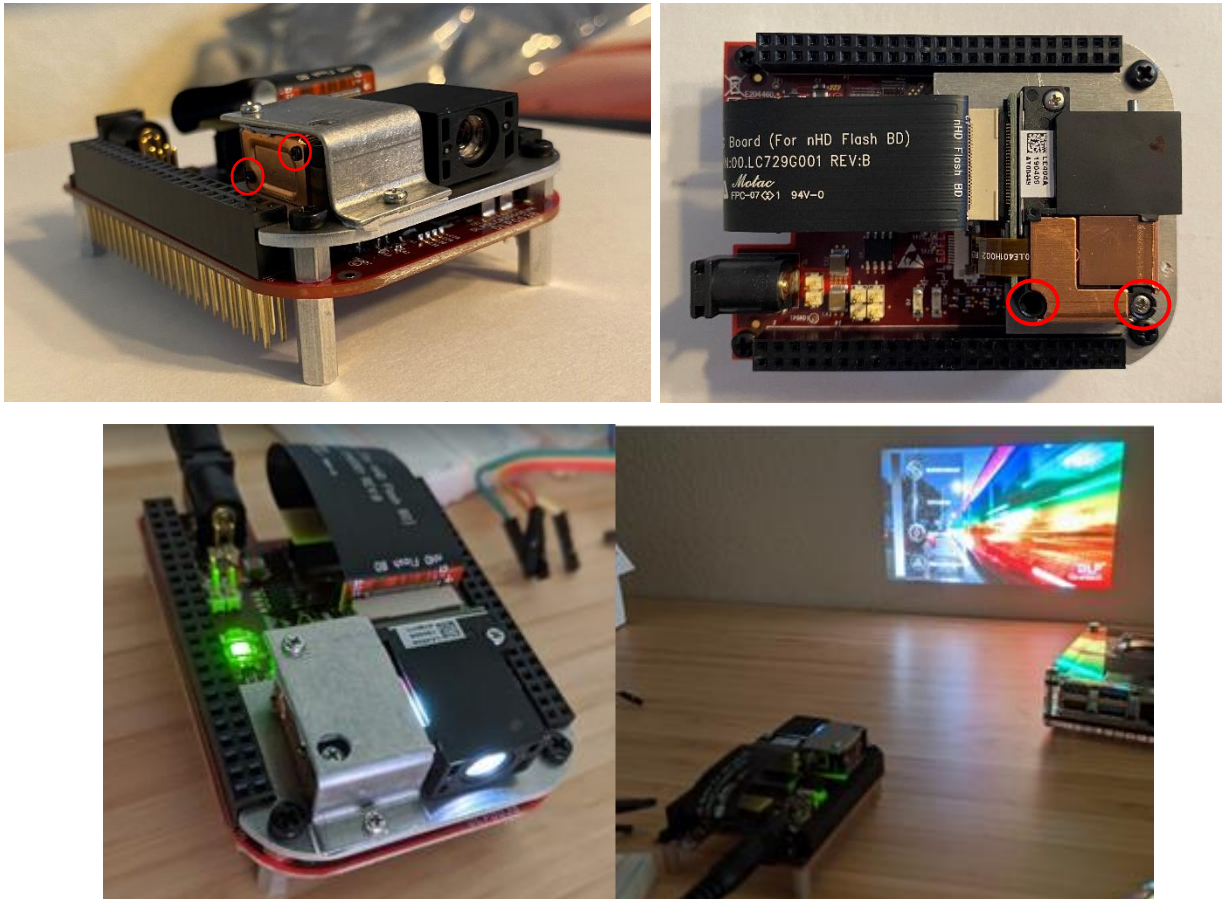

Figure 80 - Unboxed DLP2000 Optical engine and PCB. The top left image shows the module still having the silver heat sink on it; the top right image show the heat sink removed. Circled in red are the screws that need to be removed in order to expose the optics inside the engine. The bottom left and right images show the device plugged in and the EVM performing exactly as expected and promised by Texas Instruments.

Of course, we can't call it a "test without plugging it in to see if it works. According to the user guide provided with the device, if we connect power to the evaluation module, it should immediately power on and display a Texas Instruments Stock image. We plugged in a 5V DC, 3A power source plugged directly into the wall, and the display immediately illuminated, showing a beautiful stock image. The device works and is ready to be modified.

7.2.3. Laser Diodes

The three laser diodes that we need to have in our possession are the SHARP 520nm 85mw Green laser diode (GH05280E2K), Sharp 450nm 80mW Blue Laser Source (GH04580A2G), and the Mitsubishi 648nm 100mW Laser Diode

(ML101J26). Under the bias conditions given in their data sheets (summarized in Section 5.2.1. Table 12), we should expect to see outputs from the red, green and blue diodes of 100mW, 85mW, and 80mW, respectively.

Unfortunately, due to time constraints and issues with shipment from China, we have not yet received them. Due to unforeseen delays, we do not expect to have received the diodes until the middle-to-end of August. When we do receive them, however, we expect we should be able to reserve time in the Senior Design lab where we'll have access to the electronics and the power meter to test their outputs.

7.3. Software Test Environment

Quality assurance is a grand aspect in testing the standard of the product so it can eventually be given the all clear on when it can be released to the public. In the case of AUDIOVISIBLE, the Test Environment is comprised of three Raspberry Pi devices that are part of a deployment group. This allows for immediate deployment and feedback of the changes, without having to manually build and deploy the software.

However, before reaching the Test Environment, a set of Unit Tests would execute right after build, as part of our Continuous Integration pipeline. These Unit Testing will ensure the software does not fail on deployment or a bug is added to production.

8.0. Administrative Content

This section will give a detailed outline of how this project was broken down into sections with a variety of set time constraints and due dates set by either instructor/advisor or group members, also the expected/actual budget will be displayed for Summer 2020 until the completion of Fall 2020 term. The final budget was solely dependent on the group members decision.

8.1. Milestone Discussion

This section shows the breakdown of the milestone completion from the start of the Divide and Conquer assignment during Senior design 1 in Summer 2020 term until the final presentation at the end of Senior design 2 in Fall 2020 term.

Number	Task	Finish
Senior Design 1		
1	Idea	5/15/2020
2	Project Idea & Roles	5/22/2020
3	Project Report	
4	Initial Document – Divide & Conquer	5/26/2020
5	Initial Document – Divide & Conquer V2	6/7/2020
6	60 Page Draft	6/28/2020
7	Research, Documentation, and Design	
8	Power Supply	7/20/2020
9	Microcontroller	7/15/2020
10	PCB Design	7/18/2020
11	DLP Chipset	7/22/2020
12	100 Page Report	7/17/2020
13	Order Parts	7/19/2020
14	Final Document Due	7/28/2020
Senior Design 2		
15	Assemble Prototype	9/6/20
16	Testing Redesign	10/18/20
17	Finalize Prototype	11/1/20
18	Peer Report	11/15/20
19	Final Documentation	11/15/20
20	Final Presentation	TBD

Table 15: Milestones

8.2. Budget and Finance Discussion

The budget is important to us because of some of the parts and devices that are available to us to purchase can be either expensive or inexpensive. To complete the assignment, we had to look at variety of parts and make sure there is no compatibility constraints as we keep cost in mind.

Laser diodes was part of the original design, but we realize it would drastically increase the cost of our production. The new alternative we made was to use RGB LED lights because they are very efficient and low cost compared to the diodes.

Then after receiving a sponsor towards the end of the project to assist with purchasing the DLP evaluation modulation, we saved a lot of money to allow us to make the sacrifice to order the original laser diodes, which would be more easier to implement.

All the expenses included into the project will play a role in the production or testing of functionality of the project either directly or indirectly. Meaning, some parts will not be found in the design but may have been part of the part selection process, for the team decide the best course of action to ensure the project is successful in the end. We've purchased additional parts just in case for errors, hardware damage, or even to produce mock prototypes of subsections of the design to test for efficiency.

Item	Qty	Vendor	Amount
PCB Board Kit	3	OSHPark	\$20
DLP LightCrafter Display 2000 EVM	1	Texas Instrument	\$99
DLP Display Controller	1	Texas Instrument	\$17
Raspberry Pi 4	1		\$55
DLP 0.2 nHD DMD	1	Texas Instrument	\$27
Audio Speaker (4ohm)	1	SkyCraft	\$2
PMIC/LED driver	1	Texas Instrument	\$2
Semiconductor Laser Diode	3	Civillaser	\$65
MSP430 Launchpad Dev. kit	1	Texas Instrument	\$10
Projector Screen	1	eBay	\$14
Total Donations	1	BEAM Engineering Co.	(\$100)
		Subtotal	\$211
		Initial Budget	\$500
		Budget Available	\$289

Table 16: Project Budget

8.3. Purchasing Status Summary

Given the low availability of some components in the market, the lead teams and last minute changes on the Bill of Material for the project were impacted, and not every component was received in time for proper testing.

Part	Status
DLP® Display Controller for DLP2000 (0.2 nHD) DMD	Received
PMIC/LED Driver for DLP2000 (0.2 nHD) DMD	Received
PMIC/LED Driver for DLP2000 (0.2 nHD) DMD	Received
DLP® LightCrafter™ Display 2000 Evaluation Module	Received
Value Line MSP430 LaunchPad™ Development Kit	Received
DLP® 0.2 nHD DMD	Received
Raspberry Pi 4 Model B x3	Received
BeagleBone Board	Received
4 Ohm Speaker	Received
PCB	Not Received
520nm 85mw Green Laser Diode	Not Received
648nm 100mW Red Laser Diode	Not Received
450nm 80mW Blue Laser Diode	Not Received

Table 17: Part List

9.0. Conclusion

The question that inspired this project was simple: what if we could make music visible? Turn sound into light? We sought a way to do so.

Conceptually, we needed to first break down what aspect of music would be portrayed, and what kind of light signal would correspond to it. We started by breaking music down as a construct into audio signals, which quickly became clear to us to operate on the harmonic structure of music. The fundamental harmonic frequencies in the audio files we play will be the data we use for transformation. We decided that the direct analog for sound frequency in terms of light was wavelength. We identified a pre-determined scale to use to make our conversions and got to work designing a physical system that could actually do this all.

In a nutshell: AUDIOVISIBLE is a DLP pocket projector controlled by a Raspberry Pi and a printed circuit board. The Raspberry Pi receives music via a Bluetooth signal, and immediately performs Fourier analysis on it to retrieve the harmonic frequencies that make up the audio signal in real time. This data is then used to make two decisions: what color to illuminate the projector with, and what imagery to display through the projector's DLP chipset. These signals are both sent to the PCB, which powers and controls the projector subassembly.

The projector subassembly is a modified Texas Instruments DLP2000 Lightcrafter™ Evaluation Module. Because the system may not be bright enough for our purposes, we have removed the illumination subassembly -which was originally an RGB LED array- and replaced it with a laser diode-driven illumination system. The laser diodes are collimated and focused using liquid crystal diffractive waveplate lenses fabricated by hand by the photonics member of the group. The illumination will be focused directly into what remains of the pre-assembled Evaluation Module, which will focus the light directly onto a digital micromirror device and be reflected out of the system and onto a translucent viewing screen, which will be viewed from the opposite side. The projector subassembly alone will only require a single 5V DC, 3A power supply, and will be powered separately from the Raspberry Pi.

The system will have a secondary audio output subassembly for the purpose of demonstration, so that the user may still hear the music that is being visualized at the same time. The result will be an all-encompassing, fully immersive, visually engaging musical experience for all users to enjoy. We are very confident this project will succeed and become a shining example of inclusivity and innovation in the fields of music and art.

This group was fortunate enough to receive support from the company Beam Engineering for Advanced Measurements Co. (BEAM Co.) in the form of financial support, as well as the supply of diffractive waveplate technology.

10.0. Bibliography

["Prehistoric Flutes," BBC.

1

]

[G. & W. J. & M. D. Riva, "Interacting with Presence: HCI and the Sense of

2 Presence in Computer-mediated Environments.," 2014. [Online]. Available:
] [https://www.researchgate.net/publication/265896896_Interacting_with_Presence_HCI_and_the_Sense_of_Presence_in_Computer-mediated_Environments.](https://www.researchgate.net/publication/265896896_Interacting_with_Presence_HCI_and_the_Sense_of_Presence_in_Computer-mediated_Environments)

["This is your Brain on LSD," [Online]. Available:

3 [https://www.google.com/url?sa=t&rct=j&q=&esrc=s&source=web&cd=&cad=rja&uact=8&ved=2ahUKEwiGyfiFuuzqAhUSTawKHczYBAgQFjAGegQIAhAB&url=https%3A%2F%2Fbeckleyfoundation.org%2F2017%2F03%2F29%2Fthis-is-your-brain-on-lsd-and-music%2F&usg=AOvVaw3_I4GHmgwppfZ0BBrWD.](https://www.google.com/url?sa=t&rct=j&q=&esrc=s&source=web&cd=&cad=rja&uact=8&ved=2ahUKEwiGyfiFuuzqAhUSTawKHczYBAgQFjAGegQIAhAB&url=https%3A%2F%2Fbeckleyfoundation.org%2F2017%2F03%2F29%2Fthis-is-your-brain-on-lsd-and-music%2F&usg=AOvVaw3_I4GHmgwppfZ0BBrWD)

[S. B. Hairston, "Origin and Evolution of Psychedelic Music," 26 April 2018.

4 [Online]. Available: [https://medium.com/@susanbhairston/origin-and-evolution-of-psychedelic-music-287a1b5708f8.](https://medium.com/@susanbhairston/origin-and-evolution-of-psychedelic-music-287a1b5708f8)

[D. Siever, "Audio-Visual Entrainment: History, Physiology & Clinical Studies,"

5 Mind Alive Inc., [Online]. Available:
] [https://www.aapb.org/files/news/Entrainment.pdf.](https://www.aapb.org/files/news/Entrainment.pdf)

[R. L. D. a. W. Thoben, "Sound," Processing, [Online]. Available:

6 [https://processing.org/tutorials/sound/.](https://processing.org/tutorials/sound/)

]

["Light: Electromagnetic waves, the electromagnetic spectrum and photons,"

7 Khan Academy, [Online]. Available:

] [https://www.khanacademy.org/science/physics/light-waves/introduction-to-light-waves/a/light-and-the-electromagnetic-spectrum.](https://www.khanacademy.org/science/physics/light-waves/introduction-to-light-waves/a/light-and-the-electromagnetic-spectrum)

["Digital Light Processing," Science Direct, [Online]. Available:

8 [https://www.sciencedirect.com/topics/engineering/digital-light-processing.](https://www.sciencedirect.com/topics/engineering/digital-light-processing)

]

["TI DLP® technology," Texas Instruments, [Online]. Available:

9 [https://www.ti.com/dlp-chip/overview.html.](https://www.ti.com/dlp-chip/overview.html)

]

[H. Jenny, Cymatics : a study of wave phenomena and vibration, Newmarket,

1 NH: MACROmedia, 2001.

0

]

[CDM, "Traktor DJ on iPhone, Waveforms and Touch, and the Phone As
1 Desktop Companion," 2 May 2013. [Online]. Available:
1 <https://cdm.link/2013/05/traktor-dj-on-iphone-waveforms-and-touch-and-the->
] [phone-as-desktop-companion/](https://cdm.link/2013/05/traktor-dj-on-iphone-waveforms-and-touch-and-the-).

[Uncubed, "How you can replicate the trippy visuals of Google's Inceptionism,"
1 [Online]. Available: <https://uncubed.com/daily/how-you-can-replicate-the->
2 [trippy-visuals-of-googles-inceptionism/](https://uncubed.com/daily/how-you-can-replicate-the-).
]

[A. Rosebrock, "bat-country: an extendible, lightweight Python package for deep
1 dreaming with Caffe and Convolutional Neural Networks," 6 July 2016. [Online].
3 Available: <https://www.pyimagesearch.com/2015/07/06/bat-country-an->
] [extendible-lightweight-python-package-for-deep-dreaming-with-caffe-and-convolutional-neural-networks/](https://www.pyimagesearch.com/2015/07/06/bat-country-an-).

[Stack Exchange, "What's the principal difference between ANN,RNN,DNN and
1 CNN?," 2019. [Online]. Available:
4 <https://datascience.stackexchange.com/questions/58728/whats-the-principal->
] [differencebetween-](https://datascience.stackexchange.com/questions/58728/whats-the-principal-).

[M. Barr, "Introduction to Pulse Width Modulation," 1 September 2001. [Online].
1 Available: <https://barrgroup.com/embedded-systems/how-to/pwm-pulse-width->
5 [modulation](https://barrgroup.com/embedded-systems/how-to/pwm-pulse-width-). [Accessed 23 June 2020].
]

[V. Patel, "7 Ways to Improve Online Engagement With Visual Content," 17
1 March 2016. [Online]. Available: <https://www.entrepreneur.com/article/272582>.
6 [Accessed 19 June 2020].
]

[L. Joyce, "6 Types of Visual Content You Need to Use in Your Marketing
1 Campaigns," [Online]. Available: <https://neilpatel.com/blog/visual-content-you->
7 [need-to-use-in-your-marketing-campaign/](https://neilpatel.com/blog/visual-content-you-). [Accessed 18 June 2020].
]

[M. Elizabeth Scott, "How Music Can Be Therapeutic," [Online]. Available:
1 <https://www.verywellmind.com/how-and-why-music-therapy-is-effective->
8 [3145190](https://www.verywellmind.com/how-and-why-music-therapy-is-effective-). [Accessed 21 June 2020].
]

[Oxford Treatment Center, "The Differences Between Individual vs. Group
1 Therapy," 5 June 2020. [Online]. Available:

9 [https://www.oxfordtreatment.com/addiction-treatment/drug-therapy/individual-](https://www.oxfordtreatment.com/addiction-treatment/drug-therapy/individual-vs-group/)
] vs-group/. [Accessed 20 June 2020].

[D. Stachowiak, . P. Jaworski and . P. Krzaczek, "Laser-Based Monitoring of
2 CH₄, CO₂, NH₃, and H₂S in Animal Farming—System Characterization and
0 Initial Demonstration," *Sensors* (Basel), 2018.

]

[J. Baker, "The Science of Color Contrast — An Expert Designer's Guide," 25
2 June 2018. [Online]. Available: [https://medium.muz.li/the-science-of-color-](https://medium.muz.li/the-science-of-color-contrast-an-expert-designers-guide-33e84c41d156)
1 contrast-an-expert-designers-guide-33e84c41d156. [Accessed 17 July 2020].

]

[Lightform, Inc., [Online]. Available: <https://lightform.com/>.

2

2

]

[A. Payne and E. Man Kim, Artists, *Projection One*. [Art]. Harvard's Graduate
2 School of Design.

3

]

[R. Greyling, Artist, *Bluetooth Speaker*. [Art]. Bang & Olufsen.

2

4

]

[R. Anadol, "Artlecture," Pilevneli Art Gallery, March 2018. [Online]. Available:
2 https://www.youtube.com/watch?v=0gxyt5qgnoY&feature=emb_logo.

5

]

[E. E. a. C. S. Department, "ECE Senior Design," UCF, [Online]. Available:
2 <http://www.eecs.ucf.edu/seniordesign>.

6

]

[J. Cates, D. Guacaneme and L. Sweet. [Online]. Available:
2 <http://www.eecs.ucf.edu/seniordesign/fa2018sp2019/g24/>.

7

]

[J. Fabian, E. Hassan, T. Le and K. Corini, University of Central Florida, [Online].
2 Available: <http://www.eecs.ucf.edu/seniordesign/fa2015sp2016/g37/>.

8

]

["Benq.com," [Online]. Available: <https://www.benq.com/en-us/knowledge-center/knowledge/color-gamut-monitor.html>.

9

]

[N. Harbisson, "sonochromatic-scale-chord-structure," [Online]. Available: <http://iancdesign.blogspot.com/2013/02/sonochromatic-scale-chord-structure.html>.

]

[The Editors of Encyclopaedia Britannica, "Tone," [Online]. Available: <https://www.britannica.com/science/tone-sound>.

1

]

[MasterClass, "Music 101: What Is Melody?," 2 July 2019. [Online]. Available: <https://www.masterclass.com/articles/music-101-what-is-melody#what-is-melody>.

]

[Lumen, "Melody," [Online]. Available: https://courses.lumenlearning.com/musicappreciation_with_theory/chapter/melody-an-overview/.

]

[The Editors of Encyclopaedia Britannica, "Pitch," [Online]. Available: <https://www.britannica.com/art/pitch-music>.

4

]

[The Editors of Encyclopaedia Britannica, "Tone," [Online]. Available: <https://www.britannica.com/science/tone-sound>.

5

]

[C. Schmidt-Jones, "Timbre: The Color of Music," 13 November 2013. [Online]. Available: <https://cnx.org/contents/8wb7KfA0@15/Timbre-The-Color-of-Music>.

6

]

[Siyavula, "Characteristics Of A Sound Wave," [Online]. Available: <https://www.siyavula.com/read/science/grade-10/sound/10-sound-03>.

7

]

[learneasymusictheory, "Sound Waves," [Online]. Available: <http://learneasymusictheory.freehostia.com/soundwaves.shtml>.

8

]

[A. Rich, "Harmony," 9 May 2019. [Online]. Available:
3 <https://www.britannica.com/art/harmony-music>.

9

]

[P. Crossley-Holland, "Rhythm, Encyclopædia Britannica," 31 August 2017.
4 [Online]. Available: <https://www.britannica.com/art/rhythm-music>.

0

]

["Dynamics and Dynamic Changes," [Online]. Available:
4 [https://courses.lumenlearning.com/musicappreciation_with_theory/chapter/dy-](https://courses.lumenlearning.com/musicappreciation_with_theory/chapter/dynamics-and-dynamics-changes/)
1 [namics-and-dynamics-changes/](https://courses.lumenlearning.com/musicappreciation_with_theory/chapter/dynamics-and-dynamics-changes/).

]

["Articulation in Music," 13 October 2017. [Online]. Available:
4 <https://www.theflutecoach.com/articulation-in-music/> .

2

]

["Terms That Describe Texture," [Online]. Available:
4 [https://courses.lumenlearning.com/musicappreciation_with_theory/chapter/mo-](https://courses.lumenlearning.com/musicappreciation_with_theory/chapter/morphology/)
3 [rphology/](https://courses.lumenlearning.com/musicappreciation_with_theory/chapter/morphology/).

]

[F. Kirby, "Musical Form, Encyclopædia Britannica," 7 January 2015. [Online].
4 Available: <https://www.britannica.com/art/musical-form/Formal-types>.

4

]

["Why Does This Man's Head Appear Off His Body?," Wired, [Online]. Available:
4 [https://www.wired.com/2013/07/why-does-this-mans-head-appear-off-his-](https://www.wired.com/2013/07/why-does-this-mans-head-appear-off-his-body/)
5 [body/](https://www.wired.com/2013/07/why-does-this-mans-head-appear-off-his-body/).

]

[C. K. Renshaw, "Geometrical Optics: Curved Surfaces," CREOL, The College
4 of Optics and Photonics.

6

]

[D. R. Nelson Tabirian, "New 4g Optics Technology Extends Limits to the
4 Extremes," Tech Feature.

7

]

[S. B. Anand Vijayakumar, "Chapter 1: Introduction," in *Design and Fabrication of Diffractive Optical Elements with MATLAB*, SPIE Digital Library, 2017.

8

]

[N. M. & R. M. Peng Wang, "Chromatic-aberration-corrected diffractive lenses for ultra-broadband focusing," *Nature Scientific Reports*, 2016.

9

]

[M. Baron, Definitions of basic terms relating to low-molar-mass and polymer liquid crystals, International Union of Pure and Applied Chemistry, 2001.

0

]

[BEAM Co, "Diffractive Waveplate Lenses," [Online]. Available: <https://www.beamco.com/Lens-V2-Diffractive-Waveplate-Lens>.

1

]

[K. Juvva, "Real-Time Systems," 1998. [Online]. Available: https://users.ece.cmu.edu/~koopman/des_s99/real_time/.

2

]

[Jackie Kay, "Introduction to Real-time Systems," [Online]. Available: https://design.ros2.org/articles/realtime_background.html.

3

]

["ChibiOS/RT on the Raspberry Pi," [Online]. Available: <https://www.stevebate.net/chibios-rpi/GettingStarted.html>.

4

]

["A Beginner's Guide to Digital Signal Processing (DSP)," [Online]. Available: <https://www.analog.com/en/design-center/landing-pages/001/beginners-guide-to-dsp.html#>. [Accessed 26 July 2020].

]

[N. Khambhala, "How to Make a Projector at Home," YouTube, [Online]. Available: <https://www.youtube.com/watch?v=Y1yAIC7eWIQ>.

6

]

["Projector Light Source Technology," ProjectionPeople.com, [Online]. Available: <https://www.projectorpeople.com/resources/light->

7 sources.asp#:~:text=Metal%20halide%20and%20UHP%20(Ultra,mercury%20
] vapor%20to%20deliver%20light..

[ViewSonic, "What to look for in a DLP Projector," [Online]. Available:
5 <https://www.viewsonic.com/library/entertainment/what-look-for-dlp-projector/>.

8
]

["Fly's Eye Lenses," SUMITA new glass & fiber optics, [Online]. Available:
5 [https://www.sumita-opt.co.jp/en/products/flyeye-
9 lens.html#:~:text=A%20fly's%20eye%20array%20is,distribution%20at%20an
\] %20illumination%20plane..](https://www.sumita-opt.co.jp/en/products/flyeye-lens.html#:~:text=A%20fly's%20eye%20array%20is,distribution%20at%20an%20illumination%20plane..)

["DLP technology Overview," Texas Instruments, [Online]. Available:
6 <https://www.ti.com/dlp-chip/overview.html>.

0
]

[L. Hornbeck, "Digital Light Processing and MEMS: an overview," *Digest IEEE*,
6 1996.

1
]

["Wavy Circles - Desmos Graphing Calculator," desmos, [Online]. Available:
6 <https://www.desmos.com/calculator/8nomx9udco>.

2
]

[J. Wilder, "A beginner's guide to microcontrollers," [Online]. Available:
6 [https://www.microcontrollertips.com/a-beginners-guide-to-microcontrollers-
3 faq/](https://www.microcontrollertips.com/a-beginners-guide-to-microcontrollers-faq/). [Accessed 27 June 2020].

]

[ELPROCUS, "An Overview of Arduino Nano Board," [Online]. Available:
6 <https://www.elprocus.com/an-overview-of-arduino-nano-board/>. [Accessed 27
4 June 2020].

]

[A. Qureshi, "10 Best Microcontroller Boards For Hobbyists And Engineers," 4
6 September 2015. [Online]. Available: [https://wonderfulengineering.com/10-
5 best-microcontroller-boards-for-hobbyists-and-engineers/](https://wonderfulengineering.com/10-best-microcontroller-boards-for-hobbyists-and-engineers/). [Accessed 28 June
] 2020].

[Texas Instrument, "MSP430G2553 LaunchPad™ Development Kit (MSP-
6 EXP430G2ET) User's Guide," May 2013. [Online]. Available:
6 https://www.ti.com/lit/ds/slas735j/slas735j.pdf?ts=1593324684075&ref_url=htt

]

ps%253A%252F%252Fwww.ti.com%252Ftool%252FMSP-EXP430G2ET.
[Accessed 24 June 2020].

[ST, "Discovery kit with STM32F303VC MCU," [Online]. Available:
6 <https://www.st.com/en/evaluation-tools/stm32f3discovery.html>. [Accessed 28
7 June 2020].
]

["CC2640 datasheet, product information and support," Texas Instruments,
6 [Online]. Available: <https://www.ti.com/product/CC2640>. [Accessed July 2020].
8
]

["CC2640R2F data sheet, product information and support," Texas Instruments,
6 [Online]. Available: <https://www.ti.com/product/CC2640R2F>. [Accessed July
9 2020].
]

[Adafruit, "Adafruit I2S 3W Stereo Speaker Bonnet for Raspberry Pi - Mini Kit,"
7 [Online]. Available: <https://www.adafruit.com/product/3346>.
0
]

[Raspberry Pi, "Audio configuration," [Online]. Available:
7 <https://www.raspberrypi.org/documentation/configuration/audio-config.md>.
1
]

[The Sieve, "Do you really need Car Tweeters in your Audio System?," 17
7 January 2020. [Online]. Available: [https://the-sieve.com/do-you-really-need-
2 car-tweeters-in-your-audio-system/](https://the-sieve.com/do-you-really-need-2-car-tweeters-in-your-audio-system/).
]

[Texas Instrument, "LM317 3-Terminal Adjustable Regulator," [Online].
7 Available:
3 [https://www.ti.com/lit/ds/symlink/lm317.pdf?ts=1595441747722&ref_url=https
\]](https://www.ti.com/lit/ds/symlink/lm317.pdf?ts=1595441747722&ref_url=https) %253A%252F%252Fwww.google.com%252F. [Accessed 23 July 2020].

[S. G. Johnson, "Computational Photonics: Frequency and Time Domain
7 Methods," [Online]. Available: [http://ab-initio.mit.edu/photons/tutorial/compute-
4 methods@cornell.pdf](http://ab-initio.mit.edu/photons/tutorial/compute-4-methods@cornell.pdf).
]

[D. Garsten, "Homework 5," 25 April 2020. [Online]. Available:
7 https://github.com/Danielle504/CAP4630/blob/master/HW_5/HW_5.ipynb.
5
]

[U. o. Wisconsin, "A Basic Introduction To Neural Networks," [Online]. Available:
7 <http://pages.cs.wisc.edu/~bolo/shipyard/neural/local.html>.

6

]

[Tensorflow, "Why Tensorflow," [Online]. Available:
7 <https://www.tensorflow.org/about>.

7

]

[A. Unruh, "What is the TensorFlow machine intelligence platform?," 9 Noember
7 2017. [Online]. Available: [https://opensource.com/article/17/11/intro-](https://opensource.com/article/17/11/intro-tensorflow)
8 [tensorflow](https://opensource.com/article/17/11/intro-tensorflow).

]

[Tensorflow, "TensorFlow 2 quickstart for beginners," [Online]. Available:
7 <https://www.tensorflow.org/tutorials/quickstart/beginner>.

9

]

[Keras, "Keras," [Online]. Available: <https://keras.io/>.

8

0

]

[M. Heller, "What is Keras? The deep neural network API explained," 28 January
8 2019. [Online]. Available: [https://www.infoworld.com/article/3336192/what-is-](https://www.infoworld.com/article/3336192/what-is-keras-the-deep-neural-network-api-explained.html)
1 [keras-the-deep-neural-network-api-explained.html](https://www.infoworld.com/article/3336192/what-is-keras-the-deep-neural-network-api-explained.html).

]

[Keras, "The Model Class," [Online]. Available:
8 <https://keras.io/api/models/model/>.

2

]

[K. Iqbal, "WAV," 13 December 2013. [Online]. Available:
8 <https://wiki.fileformat.com/audio/wav/>.

3

]

["WAVE PCM soundfile format," [Online]. Available:
8 <http://soundfile.sapp.org/doc/WaveFormat/>.

4

]

[I. d. team. [Online]. Available: <https://librosa.org/librosa/>.

8

5

]

[B. H. McCosar, "pcsets 2.0.2," 19 August 2007. [Online]. Available:
8 <https://pypi.org/project/pcsets/#description>.

6

]

[M. G. Bastian Bechtold, "SoundFile," PySoundFile, 2015. [Online]. Available:
8 <https://pysoundfile.readthedocs.io/en/latest/#>.

7

]

[P. Steven W. Smith, "Chapter 12: The Fast Fourier Transform," DSP Guide,
8 2011. [Online]. Available: <https://www.dspguide.com/ch12/2.htm>.

8

]

[The SciPy community, "Fourier Transforms (scipy.fft)," 21 June 2020. [Online].
8 Available: <https://docs.scipy.org/doc/scipy/reference/tutorial/fft.html>.

9

]

[Stack Overflow, "Plotting a Fast Fourier Transform in Python," 2014. [Online].
9 Available: [https://stackoverflow.com/questions/25735153/plotting-a-fast-](https://stackoverflow.com/questions/25735153/plotting-a-fast-fourier-transform-in-python)
0 [fourier-transform-in-python](https://stackoverflow.com/questions/25735153/plotting-a-fast-fourier-transform-in-python).

]

[Jython Music, "Ch. 2 – Elements of Music and Code," [Online]. Available:
9 <https://jythonmusic.me/ch-2-elements-of-music-and-code/>. [Accessed 25 June
1 2020].

]

[M. Geier, "Play and Record Sound with Python," 2020. [Online]. Available:
9 <https://python-sounddevice.readthedocs.io/en/0.3.15/index.html>.

2

]

[H. Pham, "PyAudio Documentation," 2006. [Online]. Available:
9 <https://people.csail.mit.edu/hubert/pyaudio/docs/#module-pyaudio>.

3

]

[M. S. C. a. cuthbertLab, "User's Guide, Chapter 2: Notes," 25 May 2020.
9 [Online]. Available:
4 http://web.mit.edu/music21/doc/usersGuide/usersGuide_02_notes.html.

]

["What is Graphic EQ?," PreSonus, [Online]. Available:
9 <https://www.presonus.com/learn/technical-articles/What-Is-a-Graphic-Eq>.
5
]

[A. Kiffer, "The Mechanics of Music," Penn State, 2017. [Online]. Available:
9 <https://sites.psu.edu/themechanicsofmusic/2017/11/10/29/>.
6
]

[D. G. Calculator, "Wavy Circles," Desmos, [Online]. Available:
9 <https://www.desmos.com/calculator/8nomx9udco>.
7
]

[J. Kun, "Random (Psychedelic) Art," 2012 1 January. [Online]. Available:
9 <https://jeremykun.com/2012/01/01/random-psychedelic-art/>.
8
]

["Code editing. Redefined.," Visual Studio Code, [Online]. Available:
9 <https://code.visualstudio.com/>.
9
]

["Getting Started," Microsoft, [Online]. Available:
1 <https://code.visualstudio.com/docs>.
0
0
]

["Git," Git, [Online]. Available: <https://git-scm.com/>.
1
0
1
]

["Azure DevOps," Microsoft, [Online]. Available: <https://azure.microsoft.com/en-us/services/devops/>.
1
0
2
]

["Microsoft Teams," Microsoft, [Online]. Available:
1 [https://www.microsoft.com/en-us/microsoft-365/microsoft-teams/group-chat-](https://www.microsoft.com/en-us/microsoft-365/microsoft-teams/group-chat-software)
0 software.

3

]

["Eagle(program," [Online]. Available:
1 [https://en.wikipedia.org/wiki/EAGLE_\(program\)](https://en.wikipedia.org/wiki/EAGLE_(program)). [Accessed 28 June 2020].

0

4

]

[Electronics-Lab, "<https://www.electronics-lab.com/eagle-autorouter-use/>," 14
1 June 2017. [Online]. Available: [https://www.electronics-lab.com/eagle-](https://www.electronics-lab.com/eagle-autorouter-use/)
0 [autorouter-use/](https://www.electronics-lab.com/eagle-autorouter-use/). [Accessed 28 June 2020].

5

]

["PCB Design Review - Why Is It Important?," [Online]. Available:
1 <https://cadlab.io/blog/pcb-design-review-why-it-important>. [Accessed 28 June
0 2020].

6

]

[R. M. Ford and C. S. Coulston, Design for Electrical and Computer Engineers
1 - Theory Concepts, and Practice, McGraw-Hill.

0

7

]

[J. Decuir, "Bluetooth 4.0: Low Energy," [Online]. Available:
1 [https://californiaconsultants.org/wp-content/uploads/2014/05/CNSV-1205-](https://californiaconsultants.org/wp-content/uploads/2014/05/CNSV-1205-Decuir.pdf)
0 [Decuir.pdf](https://californiaconsultants.org/wp-content/uploads/2014/05/CNSV-1205-Decuir.pdf). [Accessed 24 June 2020].

8

]

["Electric Transmission," [Online]. Available:
1 [https://www.cpuc.ca.gov/Environment/info/aspen/cltp/archive/Files_8_26_14/_](https://www.cpuc.ca.gov/Environment/info/aspen/cltp/archive/Files_8_26_14/_2ElectricTransmissionFactSheet.pdf)
0 [2ElectricTransmissionFactSheet.pdf](https://www.cpuc.ca.gov/Environment/info/aspen/cltp/archive/Files_8_26_14/_2ElectricTransmissionFactSheet.pdf). [Accessed 23 June 2020].

9

]

["POWER PLUGS AND SOCKETS OF THE WORLD," [Online]. Available:
1 <https://www.power-plugs-sockets.com/us/united-states-of-america/>. [Accessed
1 26 June 2020].

0

]

[Texas Instruments, "DLP products," [Online]. Available: [https://www.ti.com/dlp-](https://www.ti.com/dlp-chip/getting-started.html)
1 [chip/getting-started.html](https://www.ti.com/dlp-chip/getting-started.html). [Accessed 27 June 2020].

1

1
]

[LaserPointSafety, "Laser Classes Chart," [Online]. Available:
1 <https://www.laserpointersafety.com/laserclasses.html#:~:text=There%20are%20four%20main%20classes,as%20the%20laser's%20power%20increases..>
2
]

["Importance of Code Quality and Coding Standard in Software Development,"
1 Multidots, 21 January 2020. [Online]. Available:
1 <https://www.multidots.com/importance-of-code-quality-and-coding-standard-in-software-development/>.
3
]

["Coding Standards and Guidelines," Geeks For Geeks, [Online]. Available:
1 <https://www.geeksforgeeks.org/coding-standards-and-guidelines/>.
1
4
]

[P. McDermott-Wells, "What is Bluetooth?," *IEEE Potentials*, vol. 23, no. 5, pp.
1 33-35, January 2005.
1
5
]

[Jnathan Goldberg, "IEEE 802.15.1-2002 - IEEE Standard for
1 Telecommunications and Information Exchange Between Systems - LAN/MAN
1 - Specific Requirements - Part 15: Wireless Medium Access Control (MAC) and
6 Physical Layer (PHY) Specifications for Wireless Personal Area Network,"
] IEEE, 14 2002 06. [Online]. Available:
https://standards.ieee.org/standard/802_15_1-2002.html.

["DLPC2607 Low-power DLP® Display Controller," March 2019. [Online].
1 Available:
1 https://www.ti.com/lit/ds/symlink/dlpc2607.pdf?ts=1595912820345&ref_url=https%253A%252F%252Fwww.ti.com%252Fproduct%252FDLPC2607.
7
]

["DLPC2607 Low-power DLP® Display Controller," [Online]. Available:
1 https://www.ti.com/lit/ds/dlps030e/dlps030e.pdf?ts=1595915487427&ref_url=https%253A%252F%252Fwww.ti.com%252Ftool%252FTIDA-01473.
1
8 [Accessed 27 July 2020].
]

[Texas Instrument, "DLPA1000 Power Management and LED Driver IC,"
1 [Online]. Available:

1 https://www.ti.com/lit/ds/symlink/dlpa1000.pdf?ts=1595880216486&ref_url=https%253A%252F%252Fwww.ti.com%252Fdocument-viewer%252FDLPA1000%252Fdatasheet%252Fapplication-and-implementation. [Accessed 25 July 2020].

[Texas Instrument, "DLPC2607 Low-power DLP® Display Controller," [Online]. Available:
1 https://www.ti.com/lit/ds/dlps030e/dlps030e.pdf?ts=1595915487427&ref_url=https%253A%252F%252Fwww.ti.com%252Ftool%252FTIDA-01473.
2 [Accessed 22 July Year].

[J. Richuso, "TI DLP® Pico™ System Design: Optical Module," Texas Instruments, [Online]. Available:
1 https://www.ti.com/lit/an/dlpa078a/dlpa078a.pdf?ts=1594835714750&ref_url=https%253A%252F%252Fwww.ti.com%252Ftool%252FDLPDLPCR2010EVM.
2]

[Electronics Tutorials, "Introduction to the Amplifier," [Online]. Available:
1 https://www.electronics-tutorials.ws/amplifier/amp_1.html.
2
2
2
]

[J. Blom, "Transistors," [Online]. Available:
1 <https://learn.sparkfun.com/tutorials/transistors/applications-ii-amplifiers>.
2
3
]

[Georgia State University, "Amplifiers," [Online]. Available:
1 <http://hyperphysics.phy-astr.gsu.edu/hbase/Audio/amp.html>.
2
4
]

[M. Evanchuk, "How to Prevent Audio Distortion," [Online]. Available:
1 <https://audiomention.com/prevent-audio-distortion/>.
2
5
]

[SL Power Electronics, "TE20," [Online]. Available:
1 <https://www.alliedelec.com/m/d/d0e29617459ce9229848dbb7291ee380.pdf>.
2
6
]

[Texas Instrument, "TI DLP® LightCrafter™ Display 2000 EVM User's Guide,"
1 [Online]. Available:
2 [https://www.ti.com/lit/ug/dlpu049c/dlpu049c.pdf?ts=1595914804337&ref_url=
7 https%253A%252F%252Fwww.ti.com%252Ftool%252FTIDA-01473.](https://www.ti.com/lit/ug/dlpu049c/dlpu049c.pdf?ts=1595914804337&ref_url=https%253A%252F%252Fwww.ti.com%252Ftool%252FTIDA-01473)
]

[M. Rehkopf, "Atlassian Agile Coach," Atlassian, 2019. [Online]. Available:
1 <https://www.atlassian.com/agile/project-management/epics>. [Accessed 2020].
2
8
]

[PCB Unlimited, [Online]. Available: www.pcbunlimited.com. [Accessed 20 July
1 2020].
2
9
]

["EasyPCB," EasyPCB, [Online]. Available: <https://easypcbusa.com/faq/>.
1
3
0
]

[[Online]. Available: www.4pcb.com. [Accessed 21 July 2020].
1
3
1
]

[[Online]. Available: www.sunstone.com.
1
3
2
]

[[Online]. Available: oshpark.com.
1
3
3
]

[G. Kim, J. Humble, P. Debois and J. Willis, The DevOps Handbook, Portland,
1 OR: IT Revolution.
3
4
]

[G. Riva, J. Waterworth and D. Murray, Interacting with Presence: HCI and the
1 Sense of Presence in Computer-mediated Environments., De Gruyter Open
3 Ltd, 2014.

5

]

[S. B. Hairston, "Medium.com," 26 April 2018. [Online]. Available:
1 [https://medium.com/@susanbhairston/origin-and-evolution-of-psychedelic-](https://medium.com/@susanbhairston/origin-and-evolution-of-psychedelic-3music-287a1b5708f8)
3 [music-287a1b5708f8](https://medium.com/@susanbhairston/origin-and-evolution-of-psychedelic-3music-287a1b5708f8).

6

]

[D. Siever, "Audio-Visual Entrainment: History, Physiology & Clinical Studies,"
1 The Association for Applied Psychophysiology and Biofeedback, Inc..

3

7

]

[B. Fry and C. Reas, "Processing.org," [Online]. Available:
1 <https://processing.org/tutorials/sound/>.

3

8

]

[V. Cheng, "Bluetooth Speakers Regulations in the United States: An Overview,"
1 16 December 2019. [Online]. Available:
3 [https://www.compliancegate.com/bluetooth-speakers-regulations-united-](https://www.compliancegate.com/bluetooth-speakers-regulations-united-9states/)
9 [states/](https://www.compliancegate.com/bluetooth-speakers-regulations-united-9states/). [Accessed 21 June 2020].

]

[FCC, "Equipment Authorization – RF Device," [Online]. Available:
1 <https://www.fcc.gov/oet/ea/rfdevice>. [Accessed 22 June 2020].

4

0

]

[DrFunk, "Another How to turn your Pi in a Bluetooth Speaker Tutorial,"
1 Raspberry Pi, 10 March 2019. [Online]. Available:
4 <https://www.raspberrypi.org/forums/viewtopic.php?t=235519>.

1

]

[D. H. Sliney, "Laser Safety," *Lasers in Surgery and Medicine*, 1995.

1

4

2

]

