

University of Central Florida
Department of Electrical Engineering and Computer Science
Instructors: Dr. Lei Wei, Dr. Richie

Senior Design I:
90 Page Final

SmartRVac

AC connected performance monitor



Customer/Sponsor: RV Intelligence
Point of Contact: Herb Gingold, herb@rviqproducts.com
Initial Project Document and Group Identification

Group C

Francisco Martinez

E. E. knarf11235@knights.ucf.edu

Claudio Leandro Afonso

Cp. E. claudio-leandro3@knights.ucf.edu

Sergio E. Perez-Aponte

Cp. E. sergioeperez@knights.ucf.edu

Table of Contents

1.	Executive Summary	1
2.	Project Description	3
2.1	Project Motivation	3
2.1.1	Physics of an AC System	3
2.1.2	Parts and their Function in an AC System.....	4
2.1.3	Failure/Critical Points in the System to Consider	5
2.2	Objectives and Goals.....	6
2.2.1	Hardware	6
2.2.2	Manipulation	7
2.2.3	Communication.....	7
2.2.4	Software.....	7
2.2.5	Power	7
2.2.6	Safety.....	8
2.3	Requirements Specifications	8
2.4	Quality of House Analysis.....	9
3.	Research related to Project Definition	10
3.1	Existing Similar Projects and Products	10
3.1.1	SENSAPHONE Remote Monitoring Solutions	10
3.1.2	Alert Labs.....	11
3.2	Relevant Technologies	12
3.2.1	Cloud Systems	12
3.2.1.1	Storage as a Service (STaaS).....	13
3.2.1.2	Data as a Service (DaaS)	13
3.2.1.3	Backend as a Service (BaaS).....	14
3.2.1.4	Test Environment as a Service (TEaaS).....	14
3.2.1.5	Software as a Service (SaaS)	15
3.2.1.6	Security as a Service (SECaaS).....	15
3.2.1.7	Infrastructure as a Service (IaaS).....	15
3.2.1.8	Platform as a Service (PaaS)	16
3.2.4	Ionic.....	16
3.2.5	Amazon DynamoDB.....	17
3.3	Strategic Components and Part Selections	17
3.3.1	Processing Chips or Boards.....	18

3.3.1.1 SoC.....	18
3.3.1.2 PSoC	18
3.3.1.3 Comparison and Selection.....	18
3.3.2 MCUs	18
3.3.3 Flash Memory	20
3.3.3.1 One Megabyte of Capacity	20
3.3.3.2 Four Megabytes of Capacity	20
3.3.3.3 Comparison and Selection.....	21
3.3.4 Sensors and Their Selections	21
3.3.4.1 Temperature Sensors	21
3.3.4.2 Humidity Sensor	25
3.3.4.4 Airflow Sensors	30
3.3.5 Communication Protocols	30
3.3.5.1 RS-485	30
3.3.5.2 UART	36
3.3.5.3 I2C	36
3.3.7 The Server or Cloud	36
3.3.7.1 Google Cloud Platform:.....	36
3.3.7.2 Amazon Web Services:.....	37
3.3.7.3 Comparison and Their Selection	37
3.3.8 The Web Application and Its Selection	39
3.4 Possible Architectures and Related Diagrams	39
3.5 Parts Selection Summary	40
3.5.1 All Selections and Costs	40
3.5.3 Bill of Materials	43
4. Related Standards and Realistic Design Constraints	46
4.1 Related Standards	46
4.1.2 The IEEE 830 Standard	46
4.1.2 IP Code ANSI/IEC 60529	47
4.2 Realistic Design Constraints.....	48
4.2.1 Economic and Time constraints	48
4.2.2 Environmental, Social, and Political constraints.....	48
4.2.2.1 Restrictions of Hazardous Substances (RoHS).....	49
4.2.2.2 Political	49

4.2.2.3 Prop 65	49
4.2.3 Health.....	49
4.2.4 Manufacturability and Sustainability constraints.....	50
5. Project Hardware and Software Design Details	51
5.1 Initial Design Architectures and Related Diagrams	51
5.1.2 Communication Data Paths	51
5.1.2.1 Sensor Communications.....	53
5.1.2.1.1 RS-485 with UART Protocol	58
5.1.2.2 Microcontroller Signals to the Thermostat.....	58
5.1.2.3 Cellphone and MCU Communication/Block Structure	59
5.1.2.4 Server and MCU Communication/Block Structure.....	59
5.1.2.5 Server and Cellphone Communication/Block Structure	60
5.1.2.6 Server and Database Communication/Block Structure	60
5.1.2.7 Full Communication Topology/Block Structure	61
5.2 First Subsystem, Breadboard Test, and Schematics.....	61
5.3 Second Subsystem, Breadboard Test, and Schematics	66
5.4 Third Subsystem, Breadboard Test, and Schematics	69
5.5 Fourth Subsystem, Breadboard Test, and Schematics.....	73
5.5.1 The CY8C6347BZI-BLD33 Microcontroller (Main Board)	73
5.5.1.1 Main MCU Flow Chart.....	73
5.5.1.2 Boot sequence:	74
5.5.1.2.1 POST sequence explanation:	76
5.5.2 The CY8C4125AXI-483 Microcontroller (Thermostat Board)	76
5.6 Software Design, Breadboard Test, and Schematics	78
5.7.1 Web Application User Stories and Their Expected Effort	78
5.7.3 Application System Architecture	79
6. Project Prototype Construction and Coding	83
6.1 PCB Vendor and Assembly	83
6.2.2 Visual Diagram of User Interface	85
7. Project Prototype Testing Plan	87
7.1 System Test Environment and Specific Test	87
7.2 User's Manual	89
7.2.1 Product Operation	89
7.2.2 Safety Precautions	90

7.2.3 Installing and Using the SmartRVac	90
7.2.4 Troubleshooting Tips	91
8. Administrative Content	92
8.1 Work Distribution	92
8.2 Milestone Discussion	92
8.2.1 Senior Design 1	92
8.2.2 Senior Design 2	93
8.3 Budget and Finance Discussion	94
Appendix A – Copyright Permissions	96
Appendix B – References	114

List of Figures

Figure 1 Quality of House Analysis	9
Figure 2 SensaPhone Sentinel	11
Figure 3 SensaPhone WSG30.....	11
Figure 4 Sentree.....	12
Figure 5 Cloud Services.....	13
Figure 6 Storage as a Service Diagram	13
Figure 7 Data as a Service Diagram.....	14
Figure 8 Backend as a Service Diagram	14
Figure 9 Test Environment as a Service Diagram	14
Figure 10 Software as a Service Diagram.....	15
Figure 11 Security as a Service Diagram	15
Figure 12 Infrastructure as a Service Diagram.....	16
Figure 13 Platform as a Service Diagram.....	16
Figure 14 Ionic Framework	17
Figure 15 Amazon DynamoDB Framework.....	17
Figure 16 AC Compressor Airflow	21
Figure 17 Other Points of AC Compressor Airflow.....	22
Figure 18 Temperature Sensing Flow Diagram	23
Figure 19 Temperature Sensors Placement.....	23
Figure 20 MCU Lookup Flow Diagram	24
Figure 21 Expansion Valve Flow Diagram	25
Figure 22 Humidity Sensor Placement	26
Figure 23 Humidity Sensing Flow Diagram	27
Figure 24 Induced Voltage Diagram	28
Figure 25 Induced Voltage Points of Measurement	28
Figure 26 Current Reading Flow Diagram.....	29
Figure 27 RS-485 Protocol.....	31
Figure 28 RS-485 Driver and Receiver Data Flow Diagram 1	31
Figure 29 RS-485 Driver and Receiver Data Flow Diagram 2.....	31
Figure 30 RS-485 Driver and Receiver Data Flow Diagram 3.....	32
Figure 31 Master-Slave Star Topology	33
Figure 32 Master-Slave Bus Topology	33
Figure 33 Master-Slave Daisy Chain Topology.....	34
Figure 34 Sensors Flow Diagram	35
Figure 35 Google Cloud Platform Map	37
Figure 36 Amazon Web Services Map	37
Figure 37 Alternative Design Block Diagram.....	40
Figure 38 Materials Received	44
Figure 39 System Data Flow Diagram.....	52
Figure 40 Sensing Data Flow Diagram.....	54
Figure 44 Interrupt Diagram	55
Figure 42 Sensor Data Bits Flow Diagram	56
Figure 43 Sensor Listening Flow Diagram	57
Figure 47 Cellphone and MCU Communication/Block Structure.....	59

Figure 48 Server and MCU Communication/Block Structure 60

Figure 49 Server and Cellphone Communication/Block Structure 60

Figure 50 Server and Database Communication/Block Structure 61

Figure 51 Full Communication Topology/Block Structure 61

Figure 52 First Subsystem (Main Board) Block Diagram..... 62

Figure 53 First Subsystem (Main Board) Schematic Part 1 63

Figure 54 First Subsystem (Main Board) Schematic Part 2..... 64

Figure 55 First Subsystem (Main Board) Schematic Part 3..... 64

Figure 56 First Subsystem (Main Board) Schematic Part 4..... 64

Figure 57 First Subsystem (Main Board) Schematic Part 5..... 65

Figure 58 Second Subsystem (Sensors Board) Block Diagram 66

Figure 59 Second Subsystem (Sensor Board) Schematic Part 1 67

Figure 60 Second Subsystem (Sensor Board) Schematic Part..... 68

Figure 61 Second Subsystem (Sensor Board) Schematic Part 3..... 68

Figure 62 Second Subsystem (Sensor Board) Schematic Part 4..... 68

Figure 63 Second Subsystem (Sensor Board) Schematic Part 5..... 69

Figure 64 Third Subsystem (Thermostat Board) Block Diagram 69

Figure 65 Third Subsystem (Thermostat Board) Schematic Part 1 70

Figure 66 Third Subsystem (Thermostat Board) Schematic Part 2 71

Figure 67 Third Subsystem (Thermostat Board) Schematic Part 3 71

Figure 68 Third Subsystem (Thermostat Board) Schematic Part 4 71

Figure 69 Third Subsystem (Thermostat Board) Schematic Part 5 72

Figure 70 Main MCU Flow Chart Part 1 73

Figure 71 Main MCU Flow Chart Part 2 74

Figure 72 POST Sequence Flow Diagram 75

Figure 73 Thermostat Board Input Flow Chart 77

Figure 74 Application System Architecture..... 80

Figure 75 Main Board PCB 83

Figure 76 Application UML Class Diagram..... 84

Figure 77 Visual Diagram of User Interface Part 1 85

Figure 75 Visual Diagram of User Interface Part 2 86

Figure 79 RGB LED Test Part 88

Figure 80 Hex Voltage Level Shifter Test..... 88

Figure 81 Potentiometer Testing..... 88

Figure 82 All Components Test 89

List of Tables

Table 1 Requirement Specification List	8
Table 2 MCUs PSoC Comparison Table	19
Table 3 PSoC 4 Comparison Table	19
Table 4 PSoC Comparison Table (Continue)	20
Table 5 Cloud Services Comparison Table	38
Table 6 Temperature Sensors Price Comparison Table	41
Table 7 Temperature Sensing Chips Price Comparison Table	41
Table 8 Humidity Sensors Price Comparison Table	42
Table 9 Current Sensors Price Comparison Table	43
Table 10 Vibration Sensors Price Comparison Table	43
Table 11 Bill of Materials	44
Table 12 List of Parts Received	45
Table 13 String of Data Format	55
Table 14 12 Bits Packet	58
Table 15 10 Bits Packet	58
Table 16 User Stories	78
Table 17 User Stories (Continue)	79
Table 18 PCB Vendors' Price Comparison Table	83
Table 19 Troubleshooting Tips	91
Table 20 Group Members Work Distributions	92
Table 21 Senior Design 1 Milestone	92
Table 22 Senior Design 2 Milestone	93
Table 23 Project Budget and Finance	94

1. Executive Summary

Traveling in an RV can be one of the best experiences in the world, especially traveling with family or loved ones. However, the fun can come screeching to a halt if the RV's AC system breaks down. For this project design, a device monitor will hook up to an RV's AC system and give real-time diagnosis and alerts to notify the user that the AC is deteriorating or needs some checking up. The RV AC monitoring device will give key performance statistics of the AC, overall health, and data on temperature, voltage, current consumption, and vibrations felt through the system. The data collected will then be stored in a cloud for storage and analyzed using big data tools. This way, families can be prepared and avoid having a troublesome malfunction during a fun vacation trip. While there is a huge product line for home AC monitoring systems, there is little attention given to RV systems. With this product, there is the hope to expand and serve customers who are interested in maintaining the health and preservation of their RV's AC with an easy to use a mobile app to interface with.

In this project, there will be three critical points in the structure of the design, two being software and the last electrical. The data gathering obtained from the sensors will be transmitted across the various locations on the AC unit to the microprocessor. The microprocessor will then interpret, calculate any derivations and algorithms and send that data to the Amazon Web Server (AWS) over an internet connection. In the first block, we have the electrical side where the microprocessor must read data points from sensors placed on the AC unit. The AC unit itself is a very electrically noisy environment made so by the fan and the compressor by the physical characteristic of superposition. Therefore, the decision was made to use the RS-485 standard because of the standard's immunity to electromagnetic interference. That data will be passed along through, the now resilient, communication lines and directed to the microprocessor.

The microcontroller unit has two routes to send data out to the server, one the route is thru Wi-Fi and the second is sending the data to the mobile app using the Bluetooth Low Energy protocol, latest one been the prefer route. The Bluetooth stack provides several formats to transmit data one of the streaming modes (SM) that utilizes the L2CAP. It easy to implement but a drawback is that it does not offer data reliability. The first step to establish a connection is to start the service discovery protocol (SDP) and decide which Bluetooth profile to use. The SDP profile is identified by the Universally Unique Identifier (UUID) that tells what the device connecting behavior. The first time the Bluetooth communication is use it must go thru the pairing and bonding process. One way the pairing can be achieve is using the secure simple pairing (SSP) utilizing the just works method for a device with limited input output capability and require very little user interaction. Once the device is paired is bonded and saved in listed of trusted devices. Every time the devices are closed it looks at the bonded list to see if there and complete the handshake. The data is sent to the phone and is prepared to send to the server or if need it to alert the user of about the AC.

The other way the MCU sends data is using a Wi-Fi network. The device must implement TCP/IP to communicate over the internet with the server. When the user setup the account it provided the mac address or serial number. When the device authenticate it does so by using it mac address or serial numbers since this are unique and have been register to a user the server knows which user data it is receiving. If a device has not been registered the session is not initialized. When the connection has been established or denied the server send back a message to let device know the next steps. If the connection is established the device starts sending data until it determines is done and send a message to terminate the session.

2. Project Description

Initially brought to UCF by a sponsored company, the idea of RV AC monitoring comes from the experience that the owner of the company has experienced. AC is very important and is now almost a necessity in American culture. Having the AC breakdown during a necessary time of need is very discomforting and annoying. Therefore, the idea for AC monitoring to the RV owner is a simple idea that has a far-reaching market in the RV business. Furthermore, the goals and objective of the project, along with the requirements and the house of quality are also explained. The idea of diagnosing the whole AC system by measuring the temperature, humidity, vibration, voltage, current, and probably pressure and air flow will be well discussed to give the user a good understanding of the whole concept of using the SmartRVac system to ensure a safe and healthy environment.

2.1 Project Motivation

With the notorious technological advancement in the last decade, it suffices to state that there are countless ways of helping society through technology. Those ways or forms of helping include creating new technologies to tackle specific society's needs, empowering individuals or organizations with tools for further advancement, facilitating lives, finding critical problems in different sectors of our society, etc. All the forms of helping falls to one simple but yet powerful concern: how to better the quality of life for as many people as possible.

AC systems are being used regularly almost everywhere in the whole world. They are present in our houses, cars, workplaces, etc., thus representing an important tool for our society. In an attempt to find how best this team could contribute to society, we decided to analyze an AC system to understand how its function and points of failure. A detailed analysis is provided in the subsections below:

2.1.1 Physics of an AC System

The most standard, common way an air conditioner works is through the use of two physical concepts: the relationship of pressure and temperature and the phase of state changes in certain types of chemicals. To understand how an AC system can control the temperature of a building, we can look at a simple phenomenon that happens in everyday life. When a person steps out of a hot shower, the hot water on the surface of the skin will take in energy from the skin causing the state of water to evaporate and change into a gas. This phenomenon is called an endothermic reaction where it takes heat away from its environment and causes a temperature decrease to happen on the skin. This state of change causes a cooling effect that is felt on the skin. Another real-life example is alcohol. Since alcohol evaporates at a lower temperature than water, it can evaporate much faster at room temperature. Therefore, when alcohol is placed on the skin, the effects of evaporation (an endothermic reaction) can be felt immediately.

AC systems take advantage of this endothermic reaction to cool air in many homes and businesses across the world. However, there is still a need to control the change in the state of matter of the liquid. To do so, we indirectly control temperature through the use of pressure by using the property where pressure is proportional to temperature. If we can control pressure, we can control temperature. From there we can control the changes of states from the type of material used. In theory, controlling state changes through pressure is a sound idea, however, not every type of material can be used. The require pressure to boil water on a normal summer day, for instance, would be enormous. There has to be a chemical used in the industry as to easily change between liquid and gas without having to reach astounding pressures to do so. That is why refrigerants R-410A is used, and R-22 in older models, to maximize the efficiency of the AC unit.

2.1.2 Parts and their Function in an AC System

There are seven main components to an AC system: The compressor, fans, evaporator, condenser, expansion valve, drier, and the chemical refrigerant to be used. To begin the walkthrough of an AC system, let us first assume the refrigerant in the system is in its liquid state first. The compressor starts the flow of the system where the liquid refrigerant is pressurized and hits the expansion valve. The expansion valve can be thought of as a small hole that controls the flow of pressure. The high pressure coming to the evaporator will translate it to a lower side of pressure. This decrease in pressure will cause the liquid refrigerant to evaporate. There has to be a delicate balance here for the transition between the high and the low side of the expansion valve. If the expansion valve lets to much cold refrigerant, then the coils will get to cold and freeze up. If the opposite happens, then the coils will start to get warm and the cold air is nonexistent.

Note here that the phase change is from liquid to a gas and the pressure is low meaning there is a temperature drop. In this stage, we would like to intuitively think that energy needs to be given to a liquid to change it to a gas. However, that is not necessary because we are lowering the pressure. If pressure is to low for a certain liquid it has nothing 'pushing' down on it to keep the molecules together allowing them to spread out. Due to the phase change of the liquid to gas, the coils in the Evaporator section will become cold. A fan is placed in this section near the evaporator to circulate the now cold air to the desired locations. At this point of the system we now have a gaseous refrigerant and now we need to recycle that refrigerant so as to reuse for the evaporator section again. We do this by re-pressurizing the refrigerant by means of the compressor.

The compressor is the biggest and most important part of the AC system. The compressor is responsible for the circulation of the refrigerant and the pressurization of the AC system. The compressor at this stage will take the gaseous refrigerant and re pressurize it to the next section of the system: the condenser. The gaseous refrigerant is hot and will need to cool down. It will travel

through the condenser coils where it is normally placed near the outside to cool the hot oils to a lower temperature.

There is also another fan placed here to disperse the heat from the coils. The dispelled heat will cause the state to condense back into a liquid and will move back to the expansion valve where the cycle will start all over again. Before reaching the expansion valve section, there is a drier that will try to extract out the moisture in the system. Moisture is also taken out of the inside of the RV through the evaporator. The warm air that is returned from the RV is pushed through the evaporator's cool coils. The warm air will condense around the coils leaving little moisture in the air being supplied to the RV.

2.1.3 Failure/Critical Points in the System to Consider

An important point of failure is the health of the compressor. Due to several issues with the system as a whole, accumulation of dirt and grime can cause the compressor to work harder and cause the compressor to overheat and fail. Current measurements can be taken to view the work output of the compressor and warn of any drastic changes in Watt output in its life cycle. Typical current consumption of an AC compressor can depend on the type of refrigerant being used and on what the capacity of the air conditioner is. Both variables can be determined by asking the user the information or simply just surveying the data and seeing normally what the average consumption is. Any defects both on the coils maintenance or the compressor will cause the compressor to work harder showing an increase in normal current usage giving us an opportunity to predict and notify the user.

Leaks in the refrigerant line can be an issue not only for the compressor but will ultimately cause your system to have no chemical to change states in, losing its functionality as an AC system. One way to measure leaks is to have pressure sensors attached to the compressor where the pressure outlet is on the high side and low side and read any abnormal changes in pressure. However, this depends on the accessibility of the compressor and if the compressor has these outlets. A sidestep to this would be to add temperature sensors on the coils themselves at critical points in the evaporator and the condenser. If there is any grime or dirt on these parts of the AC system, the coils on the high side will start to form ice around the coils.

There we can start to see any increases in temperature and alert the user of any unusual changes. Normal operating temperatures for the refrigerant R-410A are 120 degrees Celsius for the condensing state and 45 degrees Celsius for the evaporator state. Meaning a compressor must have a high side of 418 psig and a low side pressure of 130 psig. Drastic variations in temperature on the coils could give us an insight as to the maintenance of the coils themselves. This also depends on the temperature outside of the AC unit and variations will happen to the compressor usage since the AC unit will have to work harder if it is a hot day.

Therefore, positioning a temperature sensor on the outside to measure the ambient temperature on the low side can help understand why the compressor might be working harder on a certain day.

Following along this thread will be air flow and temperature differences in the output and return path of the AC unit. The term plenum is the cold air supplied to the rooms or buildings. The return path which sucks in air, should have a temperature difference compared to the plenum supply. These temperature differences are sometimes varied but usually range at around 20 degrees Fahrenheit. The airflow of the AC unit is another important factor to consider that is directly necessary to calculate the efficiency of the temperature differences. An airflow sensor can be built and placed on the Air duct to calculate whether there should be more air being blown on the condensers or vice versa depending on the temperature data of the coils and plenum/return differences. However, knowing the type of AC unit and RV size can help to know what the expected output and supply difference should be according to the necessary airflow to cool the RV's amount of Cubic Foot per Meter size.

Another point of failure is if the compressor starts to vibrate due to any moving parts becoming dislodged over time. Any moving parts that are not meant to move is extremely bad for any working design in electronics. This can affect the coils that need to be securely wrapped in the evaporator or condenser or dislodge the fan which can become inefficient at blowing air through the AC parts or ducts. This can be monitored by adding vibration sensors to the compressor and fan parts since those are the main points of the AC unit that have the highest probability of moving. Those points should be monitored if any parts break and start moving when they should not.

2.2 Objectives and Goals

The goal of the project is to create a device that helps people to monitor the operational status of their AC unit in the RV. This will make the user take control of the unit maintenance in an easy and modern way. The device will use a smartphone to make it easy to access and manage their data as well as let us to future proof the device. The objective for each area of the project is divided into the following subsections:

2.2.1 Hardware

All the hardware for the device except for the sensors should be contained in the waterproof enclosure. The sensor port to connect all the sensors to the device using one cable. Besides the sensors, all part of the device including the mounting system is to be in one package. This will make easy for the user when installing the device.

2.2.2 Manipulation

The unit main computing/control system is the microcontroller which uses a PSoC. The microcontroller will interface with the communication to send data wirelessly and receive data from the sensors. Some data analysis and data is prepared for transmission.

2.2.3 Communication

The unit will implement BLE to communicate with a smartphone to send the data collected or Wi-Fi to send the data. RS-485 serial standard will use to control and receive data from the sensors. It is expected that there will be no inputs coming from the user besides to pair and bond the unit the first time unit is register to the user account and when the device re-connected to the phone by looking at the bond list.

The mobile application will communicate to the server to pass the data collected from the device. The same process is used in case the device sends data to display immediately as alert or notification. In case the phone is not in range the Wi-Fi connection is used. The TCP/IP protocol is used to establish a connection to the server. The session will be initialized, and the server will send back a message to the device that is ready to receive the data. Once the device is done sending data the session is terminated.

2.2.4 Software

The software will be divided into two sections, embedded code, and the mobile application. The embedded code will consist of methods that will control the data flow and manipulation as well as communication with sensors and the mobile application. The mobile application will implement features to display the data received from the device as well as data from the server. Also, the data received from the device will be sent to the backend to be stored and analyzed. The UX should be intuitive and easy to use. The mobile application will have to user levels, general users and superuser. The later will provided tools and functions available to this user to maintain and verify the device.

2.2.5 Power

The system power supply design will be built around the 12V battery supplied by the RV. A step-down voltage will be used to bring down the battery to a safe level for the components to use. Each board will be fed the 12V line to step down the voltage at each level.

2.2.6 Safety

The device should not be designed in a manner that could distract the user while driving or endanger the user while operational. The mounting mechanism should maintain the device secured and in place. Sensors should not interfere with the operation of the AC unit or RV.

2.3 Requirements Specifications

The functional requirements of the system have been provided in the table below, Table 1, and they can be practically checked:

Table 1 Requirement Specification List

The device should not weight more than 1lb
The device should be 6in X 2in X 2in
The device should step down 12v to 5v
The device enclosure should be IP-69 (waterproof/weatherproof)
The device shall have a microcomputer and Bluetooth low energy.
The device shall measure voltage and current usage
The device shall sense the temperature, moisture, and vibrations
The device shall have 3 LEDs to indicate transmission, operation and if it connected to a phone.
The device shall operate below 95F(35C).
The device shall be easy to set up and minimal setup time
The device shall send a notification to the phone when temperature, moisture, vibrations exceed the threshold.
The device shall be easy to pair with the mobile app
The mobile application shall be easy to use
The mobile application shall have animations for startup, loading, and transitions.
The mobile app UX shall display the data in an easy to read manner.
The mobile application shall have a super and different regular user mode
The mobile application shall receive data from the device and send to the server
The server should store and compute data to estimate the life of the AC unit
The server shall have an authentication and registration methods
The mobile application should identify the type of user according to their login information.
The superuser should have total access to the system.
The regular users should have limited access to the system.
The user should be notified of their signed account type to ensure they know what type of privileges they own on the system.
Generate easy to use user's manual, test procedures, and FAQs

2.4 Quality of House Analysis

The project must be user-friendly for the customer with as little installation hassle as possible. There will be two options for the user where it will give them the option to be hands-free or down to the bit by bit data points and statistics. The device will have to be durable in order to sustain the harsh environment of the AC unit with constantly changing temperatures inside. The size impact will be debatable and subject to change but will need to include the packaging for the sensors and placement of them as well. The product might suffer in the user-friendly aspect of this but there is no set procedure of how the product will be produced and sold. There might be the possibility of professional installers working with customers and installing the device on for them with little effort from the consumer as possible. Therefore, in that aspect the user interface is better as well as the quick setup. Even without the installer, the sensors and packages will be constructed to be easy to use as possible. Cost is still undetermined in this stage of the project. The figure below, Fig. 1, gives a visual explanation of the quality of the project:

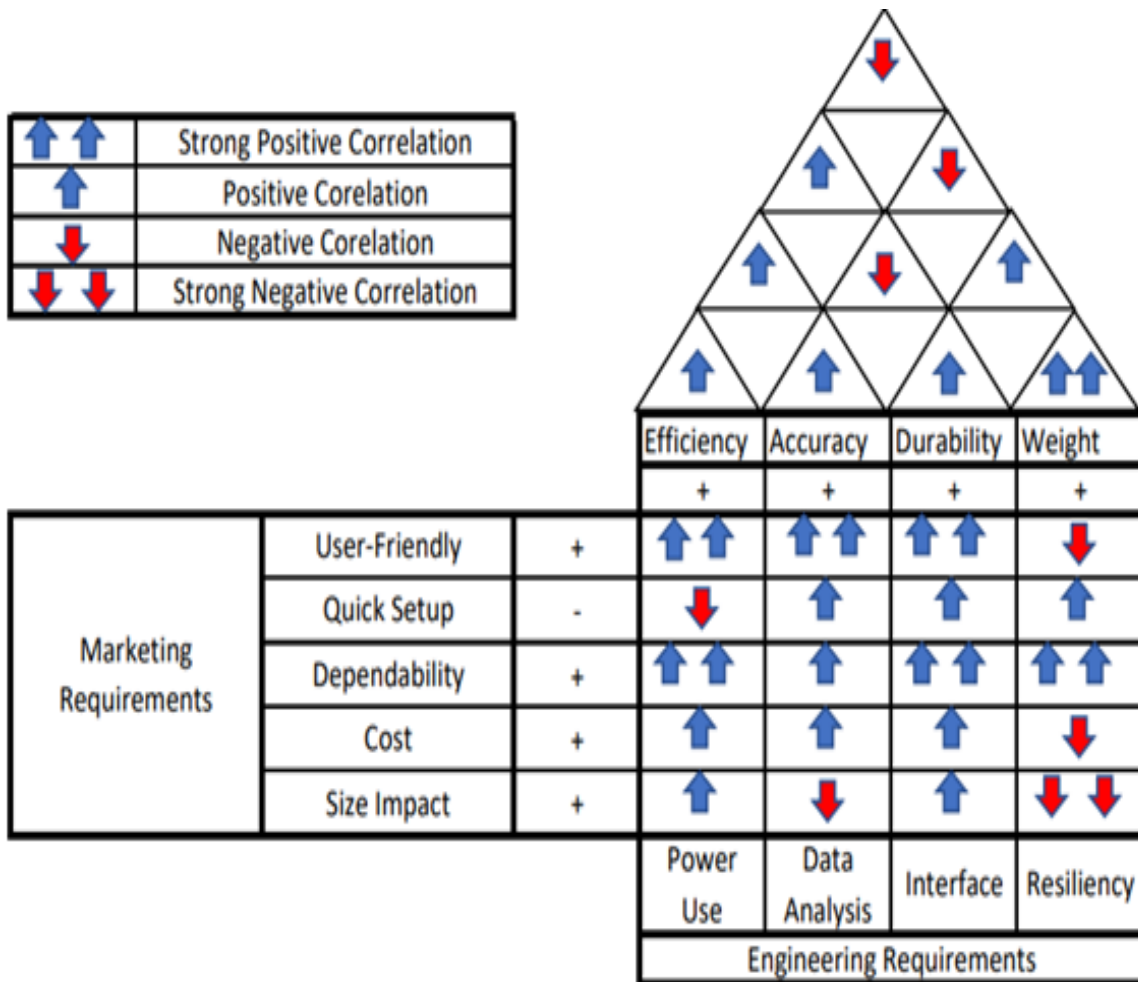

Figure 1 Quality of House Analysis

3. Research related to Project Definition

This section will provide a concise explanation of the intensive research the team has conducted on AC systems for RVs. This research ranges from mobile applications, databases, web servers, to communication protocols, decoding and encoding techniques, and sensing techniques that are being proposed. To date no smart AC system control for RV system has been created yet, thus causing the creation of this novel technology to be research intensive. We visited different academic and commercial sources, including scholarly articles, academic and commercial websites, and AC product catalogs.

All the extensive research we have conducted so far were to help easy and ensure accurate part selections. They also help to analyze the market for existing similar projects or products, as well as the best AC systems for RV in the currently in the market. The explanations below will introduce the needed areas of design and help make a good assertion of a project final design that will accomplish the design specifications requirements as mentioned in section 2.3 on pages 8 and 9 and Table 1:

3.1 Existing Similar Projects and Products

As it was mentioned before, SmartRVac seems to be the first of its kind. Nevertheless, the following subsections will provide brief explanations on the closest products to this system that are currently in the market. Most of the products that share functionality to our project are implemented in the business units and a growing section in home automation.

Note that this project may use one of those AC systems since it is meant to diagnose the lifecycle of RV ac systems and the environment affected by them.

3.1.1 SENSAPHONE Remote Monitoring Solutions

This company offers several products to monitor HVAC systems in building such as data centers, cold stores units, etc. The company offers two products that have some functionalities that our project is planning to implement.

Sensaphone Sentinel, shown in Figure 2, is device design to monitor HVAC 24 hours a day with small inputs from the user. It collects data from sensors and sends data to the cloud for sending alerts and or reporting. Some of the sensors data that can be collected are temperatures, humidity, pressure, water leak and other. The device can monitor up to 12 different areas. The user can access information and change system setting thru their mobile app or website.



Figure 2 SensaPhone Sentinel (Courtesy of Sensaphone)

Figure 3 shows the other product offer by Sensaphone called WSG30. This product remotely monitors HVAC systems, chillers, walk-in refrigerator unit, and other untended facilities. This unit is meant to work with wireless sensors and can support up to 30 of them, just like the sentinel unit the WSG30 can be accessed through the web to make changes and see the log data.



Figure 3 SensaPhone WSG30 (Courtesy of Sensaphone)

3.1.2 Alert Labs

Alert Labs offers the Sentrete A/C monitoring system. This a small unit that uses a cellular network to send data to their server. The data can be access thru their website and mobile application with two versions available, the homeowner app

and the contractors' app. The unit has a sensor for temperature, pressure and current sensor. It can show historical data and analyze data to provide a maintenance schedule and unit performance.



Figure 4 Sentree (Courtesy of cdn.shopify.com)

3.2 Relevant Technologies

Several technologies were researched in order to find the best fit for our product. Those researches included the signal each device or system can transmit, receive, or store, how they store information, the programming languages they use, how they access information, and the type of connections they require. Since most of those technologies are cloud or database systems available to the public, this section will start with a brief explanation of what both types of systems are, the services they provide, and the main differences between them.

3.2.1 Cloud Systems

Also referred to as “cloud computing,” is a recently implemented and still growing technology (application type and platform) that empowers individuals or organizational entities to use shared services in a cost-effect and easy way. Those services can be virtually or physically provided. Many cloud systems also include security and optimized network services.

Different from local systems, in cloud systems the applications run on remote machines and are hosted by a web-based service. For users to use the applications, they need to log into that web service that hosts all the applications running on the cloud system. Those systems are divided into two parts: the backend which is the cloud, and the frontend which is the part seen by the users.

The following figure, Figure 5, will give a better idea of how cloud systems work. It also briefly shows the different cloud services. However, more explanations will be provided in the next subsections.



Figure 5 Cloud Services (Courtesy of www.whereinguate.com)

The different types of services provided by cloud systems are shown in the subsections below:

3.2.1.1 Storage as a Service (STaaS)

In this service, a large entity provides a storage infrastructure to be rented by corporations or individuals. The clients rent a space in the storage and use it on a subscription basis.

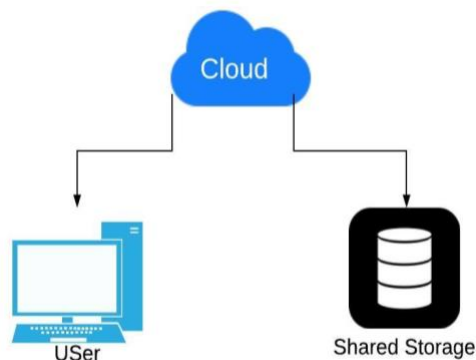

Figure 6 Storage as a Service Diagram (Courtesy of www.whereinguate.com)

3.2.1.2 Data as a Service (DaaS)

In this service, a large entity provides data to be rented by corporations or individuals physically located nearby or far away. The clients rent those data mainly for training or measurement purposes.

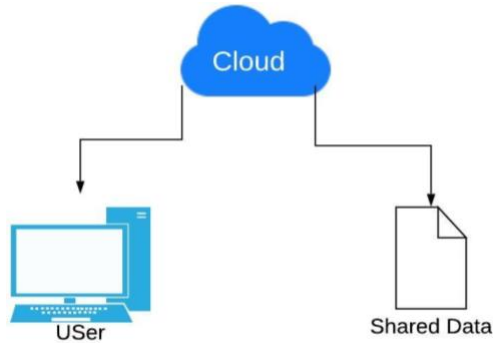

Figure 7 Data as a Service Diagram (Courtesy of www.whereinguate.com)

3.2.1.3 Backend as a Service (BaaS)

In this service, a large entity provides features such as social network integration services and user management that can be rented by corporations or individuals. The clients are mainly mobile or web developers and use it on a subscription basis to link their applications to backend cloud systems.

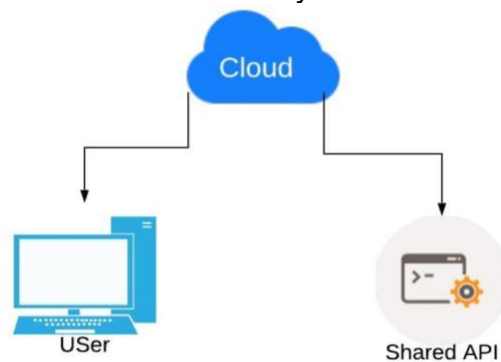

Figure 8 Backend as a Service Diagram (Courtesy of www.whereinguate.com)

3.2.1.4 Test Environment as a Service (TEaaS)

In this service, a large entity provides a test environment delivery model to be rented by corporations or individuals. The clients access it usually using a web browser on a subscription basis.

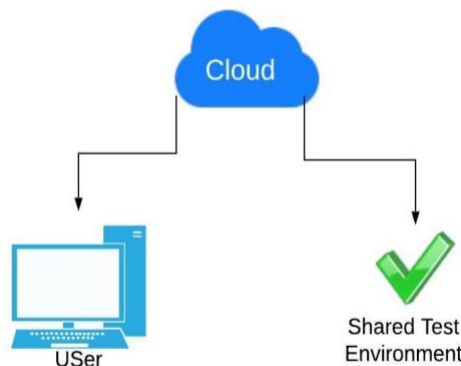

Figure 9 Test Environment as a Service Diagram (Courtesy of www.whereinguate.com)

3.2.1.5 Software as a Service (SaaS)

In this service, a large entity provides a set of applications to be rented by corporations or individuals. The clients access the applications over the internet on a subscription basis.

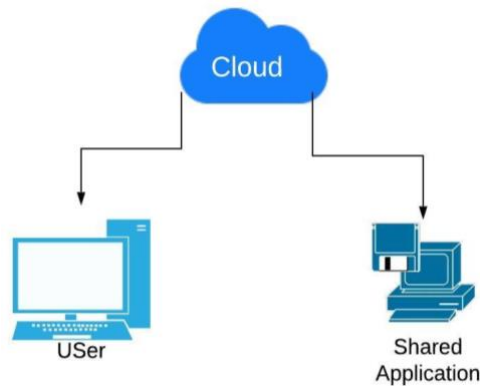

Figure 10 Software as a Service Diagram (Courtesy of www.whereinguate.com)

3.2.1.6 Security as a Service (SECaaS)

In this service, a large entity provides security services to be rented by corporations or individuals. The clients implement those security measurements into their infrastructure on a subscription basis.

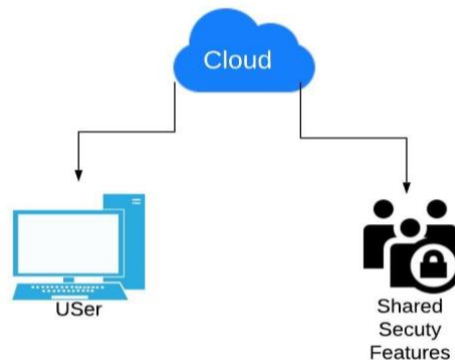

Figure 11 Security as a Service Diagram (Courtesy of www.whereinguate.com)

3.2.1.7 Infrastructure as a Service (IaaS)

In this service, a large entity provides hardware resources to be rented by corporations or individuals. The clients receive those hardware resources as virtualization services and use them on a subscription basis.

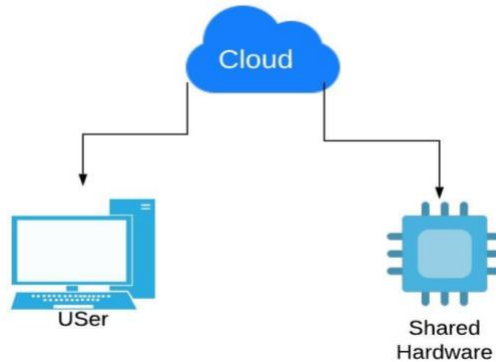

Figure 12 Infrastructure as a Service Diagram (Courtesy of www.whereinguate.com)

3.2.1.8 Platform as a Service (PaaS)

In this service, a large entity provides an application platform to be rented by corporations or individuals. The clients use it on a subscription basis.

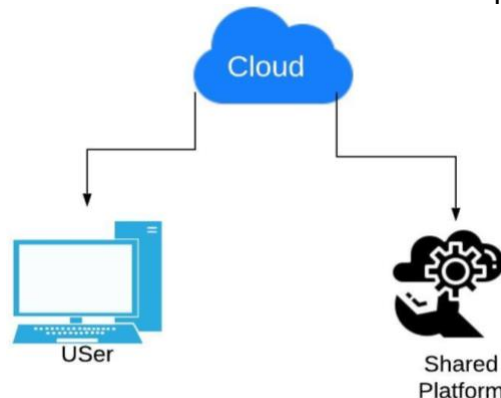

Figure 13 Platform as a Service Diagram (Courtesy of www.whereinguate.com)

3.2.4 Ionic

Ionic is a free and open source SDK that let the developer build a mobile application and web application easily. The idea of using Ionic is the ability to create an app for multiple platforms from one code base. Ionic is easy to use since it uses HTML, CSS, JavaScript and Web APIs. it can also use other JavaScript frameworks such as Angular and React to make development easy and use pre-built components. The picture below shows how the framework works with different technologies. The figure below, Figure 14, shows the whole framework:

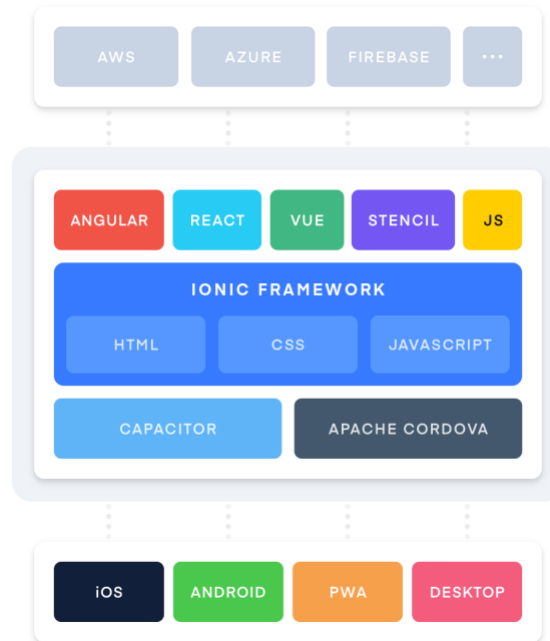

Figure 14 Ionic Framework (Courtesy of ionicframework.com)

3.2.5 Amazon DynamoDB

DynamoDB is a NoSQL database included in the AWS subscription that offers key-value mapping and data structures. The figure below, Figure 15, shows the whole framework:

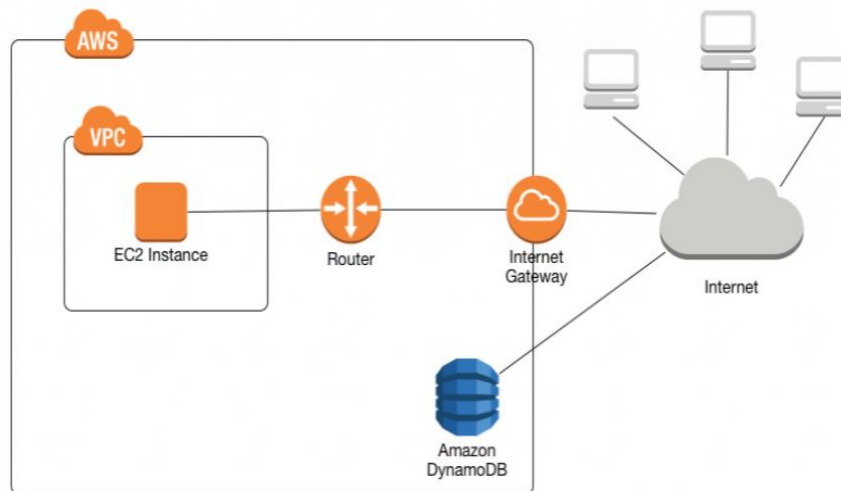

Figure 15 Amazon DynamoDB Framework (Courtesy of AWS)

3.3 Strategic Components and Part Selections

In this subsection some strategic components or parts were defined. By strategic we intend to emphasize the fact that the listed components are used to facilitate achieving the functionalities effectively.

3.3.1 Processing Chips or Boards

As software focusing more in performance, hardware built for specific functions becomes indispensable. However, by building dedicated hardware flexibility is hurt. Getting a good balance between CPU cores, configurable hardware and fixed functions is what define as system on chip (SoC) technology. This technology offers advantages like more configuration than Arduino or MSP430 series microcontroller, and more functional configuration than a FPGA by bringing these features together in a single platform.

3.3.1.1 SoC

SoC offer a mix of features in it design such as performance, low energy, and optimized design. One area that SoC having booming is in the Internet of Things (IoT) because of the low energy consumption, and the right amount of functionality the device needs. When analog paths are paired with digital paths and memory in the SoC we get the programmable system on chip (PSoC).

3.3.1.2 PSoC

PSoC have a microcontroller core, programmable logic, and hardwire blocks. PSoC are different because of the configurable analog peripherals, which is make operational by the use of switch capacitors, op amps, ADCs, DACs, comparators, and digital filter blocks. These technologies let create complex analog signal paths that link to the digital functions on the chip.

3.3.1.3 Comparison and Selection

Our project requires to work with analog sensor and digital sensors to read data at different points to monitor an RV AC unit. The data collected need to be store before been sent to the mobile app utilizing Bluetooth Low Energy (BLE). for this reason, the team decided to use PSoC from Cypress Semiconductors. They are a major player on the PSoC market and have products with BLE on the chip.

3.3.2 MCUs

For the project we are going to utilize two types of MCU, one with built in BLE for the main board and the other without BLE for the sensor and thermostat boards. Since the MCU with BLE requires an antenna, we are looking at those in the module style package. The manufacturer refers to these as the Creator Modules. These offers the PSoC, antenna, and some of the models have the certifications from different countries. Below is a table comparing four Creator modules for the main board.

Table 2 MCUs PSoC Comparison Table

SPECIFICATIONS	CYBLE-222005-00	CYBLE-416045-02	CYBLE-214009-00	CYBLE-012011-00
CPU (ARM CORTEX)	M0	M4F and M0+	M0	M0
FREQUENCY (MHz)	48	150 and 100	48	48
FLASH (KB)	256	1024	256	128
SRAM (KB)	32	288	32	16
GPIO PINS	16	36	25	23
SBC (I2C, I2S, UART, SPI)	2	5	2	2
TCPWM (Timer 16bit)	4	32 (24 16Bit, 8 32Bit)	4	4
RTC	YES	YES	YES	YES
DMA	0	2, 16 Channel	0	8
ADC	12 BIT SAR, 1 Msps	12 BIT SAR, 1 Msps	12BIT SAR, 1Msps	12BIT SAR, 1Msps
IDAC	4	2	2	2
OPAMP	4	2	4	2
COMPARATOR	4	2	1	4
SMART I/O	0	2	0	0
UDB	4	12	4	N/A
Min VCC	1.71V	1.71V	1.7V	1.71V
Max VCC	5.5V	3.6V	5.5V	5.5V
Bluetooth LE (Ver.)	4.1	5.0	4.1	4.1
ANNTEANA	Chip	PCB	PCB	PCB

We were looking at the CYBLE-416045-02 but ended selecting the CYBLE-222005-00 out the four because of availability of the product. Since the board functions are to receive the readings, process, store and send the data through Bluetooth then the number of pins needed should not be more than 16. The board only require four pins for serial communication between boards, four for the extra flash memory, six pins for the LEDs and two for the humidity temperature sensor. This module offers the needed pins, 256 KB of flash for the program, a real time clock, enough processing power, BLE and a chip antenna in small footprint. For the sensor and thermostat boards we look for the MCU that have the minimum requirement at the lowest price. The tables below, Table 3 and 4, show the three PSoC 4 we consider for the boards.

Table 3 PSoC 4 Comparison Table

SPECIFICATIONS	CY8C4125AXI-483	CY8C4146AZI-S433	CY8C4147AZQ-S455
CPU (ARM CORTEX)	M0	M0+	M0+
FREQUENCY (MHz)	24	48	48
FLASH (KB)	32	64	128
SRAM (KB)	4	8	16
GPIO PINS	36	36	54
SBC (I2C, I2S, UART, SPI)	2	3	4
TCPWM (Timer 16bit)	4	5	8

Table 4 PSoC Comparison Table (Continue)

SPECIFICATIONS	CY8C4125AXI-483	CY8C4146AZI-S433	CY8C4147AZQ-S455
DMA	0	0	8
ADC	12 BIT SAR, 806 ksp/s	12 BIT SAR, 1 Msp/s	12BIT SAR, 1Msp/s
iDAC	2	2	2
OPAMP	2	2	2
COMPARATOR	2	2	2
SMART I/O	0	16	24
UDB	0	0	0
Min VCC	1.71V	1.71V	1.71V
Max VCC	5.5V	3.6V	5.5V

We only needed two serial blocks, one to communicate with the main board and one for I2C use with all the sensors. Three pins for the LED, four pins for the dip switch, two pins for the reset, two for the temperature, two for the current reader, two for the accelerometer, and three for the RS-485. This PSoC have 36 pins which we only need 18, in terms of memory 32 KB of flash which is enough for the program.

Both MCUs have the capabilities our project requires and are in a price range that is affordable for production. Also, we have replacement for the MCUs in case availability changes.

3.3.3 Flash Memory

In our project we need to have additional memory to store data collected before it is transmitted, which can be used as our buffer. We are planning to use flash memory because is cheaper than ram and is also nonvolatile.

3.3.3.1 One Megabyte of Capacity

When deciding the right capacity of the flash memory, we first considered the one-megabit flash storage. One megabit is equivalent to 1,048,576 bits.

3.3.3.2 Four Megabytes of Capacity

We also considered the four megabits flash storage. 4 megabits are equivalent to 4,194,304 bits.

3.3.3.3 Comparison and Selection

We have five sensors in our projects. Per second, each sensor will transmit a sensing reading of 8 bits, therefore 40 bits per second. Hourly, the sensors will send 40 bits times 3600 seconds, therefore, 144,000 bits per hour. Daily, our sensors will be generating approximately 144,000 bits times 24, therefore, 3,456,000 bits per day.

From those calculations, we concluded that to effectively store all of the information in our buffer, already taking into account the transmission errors that may occur during the transmitter or receiver side, we need the four megabytes flash storage.

3.3.4 Sensors and Their Selections

The system will use different sensors to monitor the health of the AC system for analysis and diagnosis purposes. Those types of sensors and how they function will be explained in the following subsections:

3.3.4.1 Temperature Sensors

Temperature sensors are required for three sections: Evaporator ducts and coils, Condenser ducts and coils, and the expansion valve. We will need to read the return air coming from the inside, and the air being supplied by the evaporator. From this setup, we can measure the temperature difference to see if the evaporator is working correctly by taking the difference between the return and supply ducts, as shown in the figure below, Figure 16. The difference in temperature should be within 20 deg Celsius or 68 deg Fahrenheit.

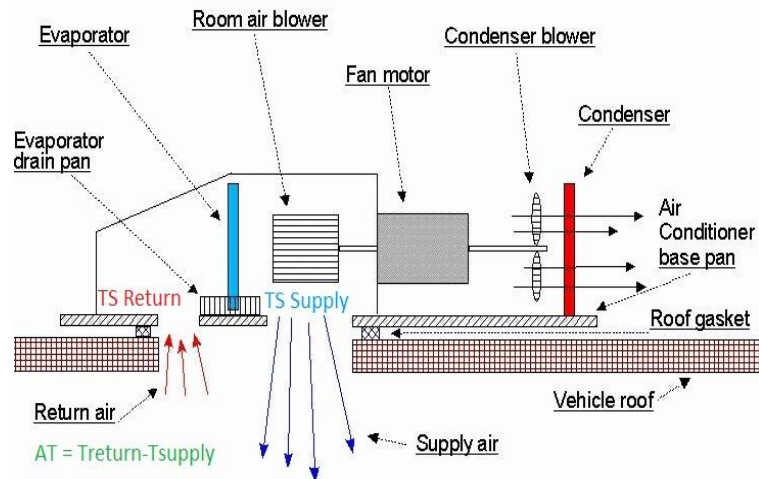

Figure 16 AC Compressor Airflow (Courtesy of Bryant RV Services)

Since the temperatures are contained in a small vent and are dependent on the air. A contactless sensor can be used here to measure the temperature. The sensor should also be able to operate in the temperature ranges of 50 to 80-degree Fahrenheit ranges (or from 10 to 27 deg Celsius). The temperature reads should also be read when there is a steady state of the AC unit where it has had some time to start in the AC unit cycle where the compressor turns on again to start cooling the home. For the condenser side, the temperature sensors should be placed on the exhaust of the fan, and another on the outside to read the heat exchange between the two. The temperatures should have a differential where the condenser heat is being transferred to the cooler air on the outside. If the differential is too small, then there may be a problem of too low refrigerant. Other data points on the compressor, airflow, and even evaporator data should be looked at to verify the problem or identify other problems.

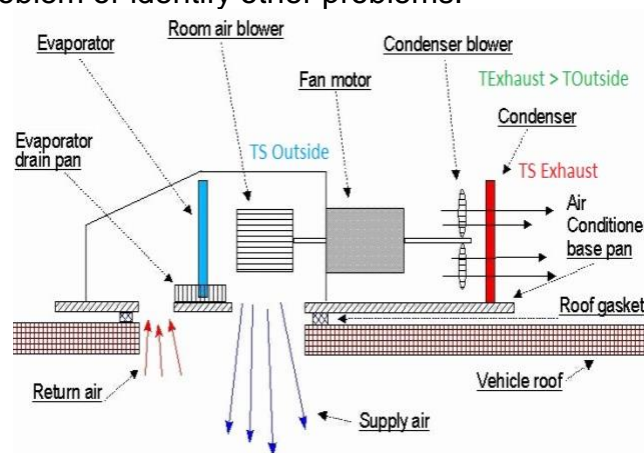

Figure 17 Other Points of AC Compressor Airflow (Courtesy of Bryant RV Services)

The sensors are required to be able to read between 80- and 120-degrees Fahrenheit. They can also be contactless since the temperature sensor is reading the air being blown and the outside ambient temperature. The flow diagram is very similar to the evaporator diagram and is shown below in Figure 18:

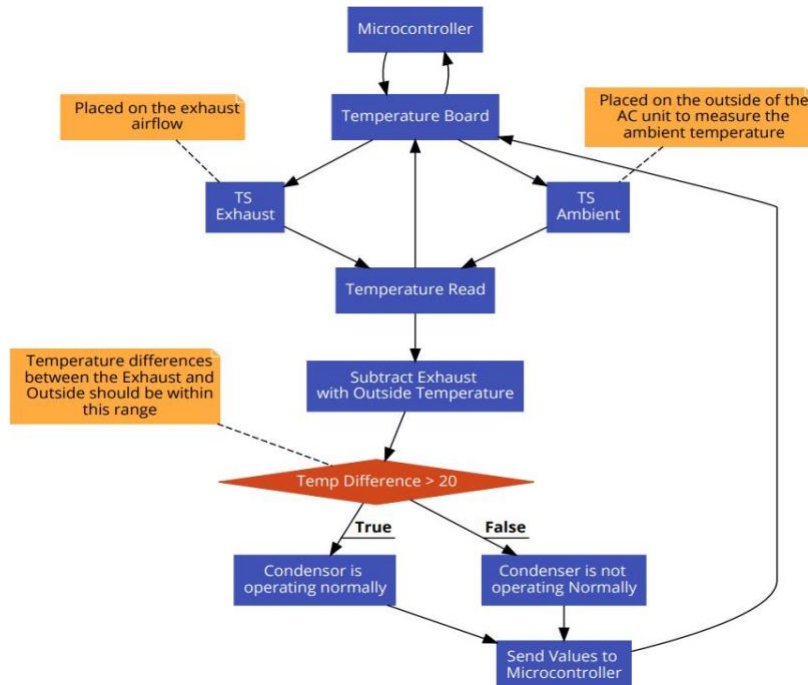

Figure 18 Temperature Sensing Flow Diagram

The last set of temperature sensors need to go on the coils of the evaporator and the condenser. The compressor changes the pressure to get the R-410A refrigerant to change states easier in the pipes. This way the temperatures change because of the changes of states in matter. The temperature reads on the coils can give us a wealth of information on how well the compressor is doing its job in changing the pressure. We would have to have a temperature to pressure conversion chart of the known refrigerant and intake the data. The temperature sensors would have to be placed as on the coils as shown below:

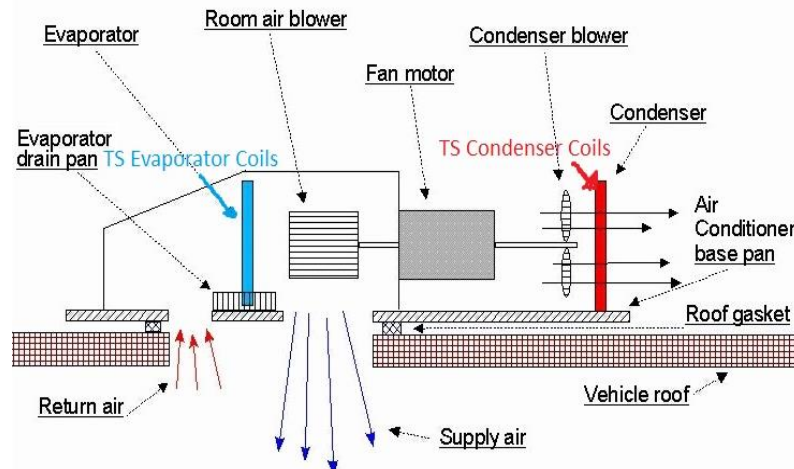

Figure 19 Temperature Sensors Placement (Courtesy of Bryant RV Services)

The look-up table for the microprocessor to verify is shown in this appendix. The temperature sensors are required to contact and need to operate between -10 deg

Celsius and 130 deg Celsius (or 14 and 248 deg Fahrenheit). The flow diagram is shown below:

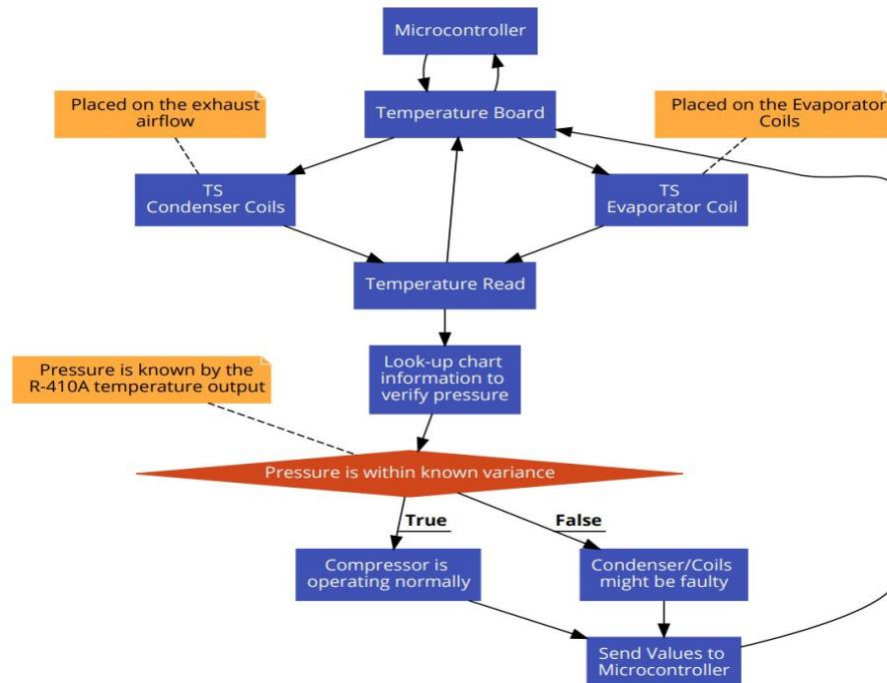

Figure 20 MCU Lookup Flow Diagram

The expansion valve is an important feature in the mechanical aspect of the refrigeration process. It lets the pressurized liquid expand out of the hole inside the valve and turn into a gas because of the rapid decrease in pressure. The critical point to read pressure (or temperature) is at the cool side of the valve. The valve's design criteria are to keep the refrigerant 4 to 7 deg Celsius above its boiling point. This excess temperature above the temperature point is known as the superheat. The known boiling point of the refrigerant is known and so the temperature at the cool side of the valve can be monitored to view the behavior of the valve.

The valve can also be monitored at the hot side to see how the pressure differential is changing over time. Increased pressure or a decrease can signal that the compressor is working harder or not able to pump the same pressure as before. Another area that can be probed is the thermal bulb. The thermal bulb is filled with CO₂ and expands to lower the flow of refrigerant. This is done so as to not let the refrigerant become too cold that it freezes the coils and stops flow altogether. The data recorded at the bulb and the temperature variations of the expansion valve can be accounted for.

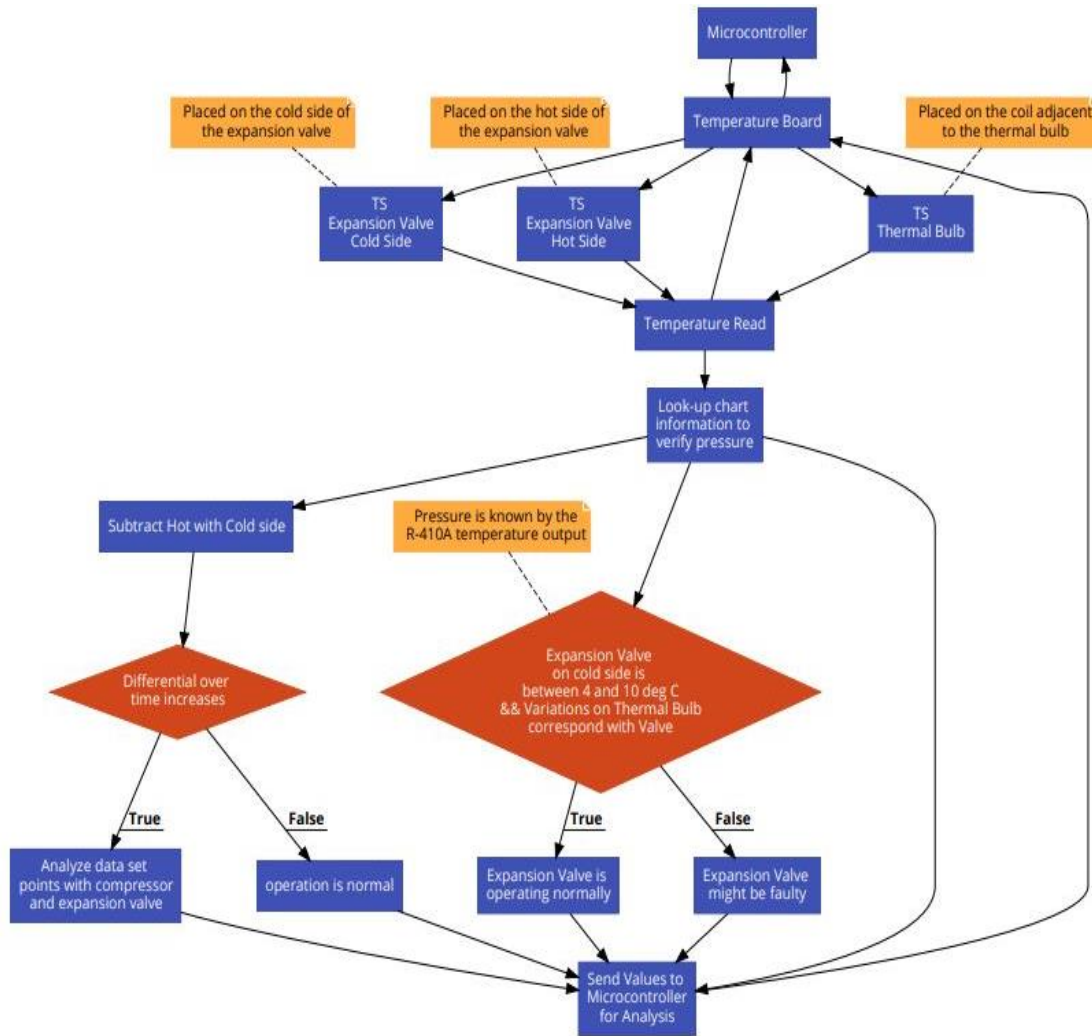

Figure 21 Expansion Valve Flow Diagram

3.3.4.2 Humidity Sensor

According to the American Society of Heating, Refrigeration, and Air-Conditioning (ASHRAE), the relative humidity inside a room should be around 20 to 50 percent for both human comfort and minimizing the risk of mold, bacteria, and disease to grow since those listed like to thrive in humid environments. An increase in humidity with the AC on means that the evaporator is not functioning properly since the evaporator condenses the warm air being blown on it from the return and outside air. Since the evaporator condenses some of the moisture in the air, the rest is blown through the rest of the RV. Humidity Sensors can be placed in the following sections on the AC unit below:

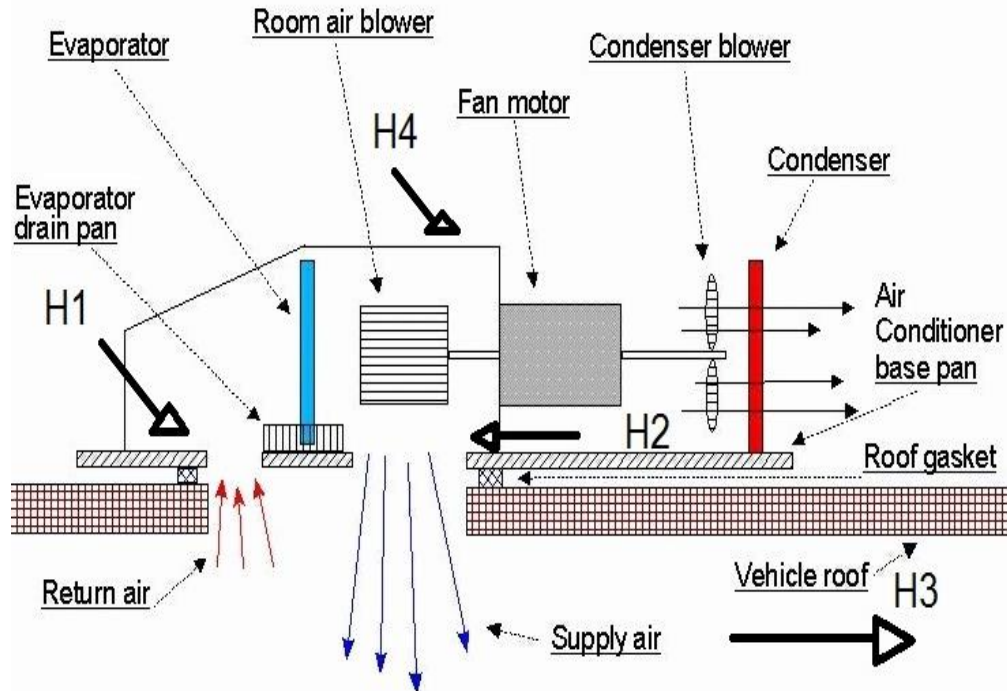

Figure 22 Humidity Sensor Placement (Courtesy of Bryant RV Services)

Humidity sensor one and two will be what determines the differential rate that humidity is decreasing by. For instance, as the AC unit starts there is a known amount of stale humidity. That humidity will decrease as the return moisture condenses on the evaporator coils. The decrease will be felt across the ambient humidity sensor in the room (H3).

H4 will measure the outside humidity as well. Depending on the other data points, decreasing efficiency of the extraction of humidity can be caused by degradation of the fan or compressor. Over time, parts will fail especially for the fan and compressor, but control over humidity is essentially important to the comfort and health of the customer and must be a priority if degradation becomes too much and the humidity efficiency suffers because of it. The following diagram will give a better understanding of the whole process just described above:

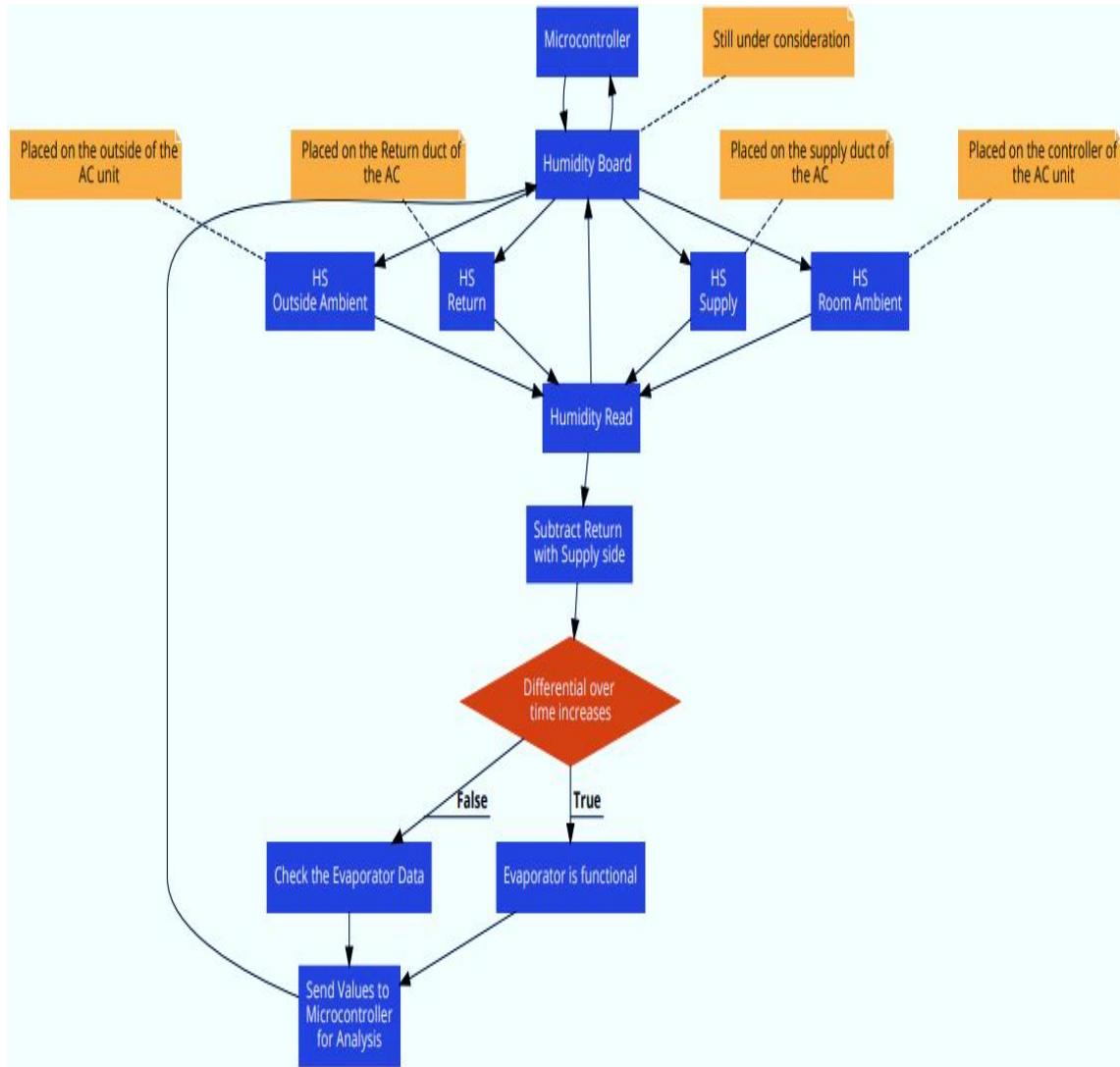

Figure 23 Humidity Sensing Flow Diagram

3.3.4.3 Current Sensor

As time passed, the compressor and the fan will reach the end of their tested life cycles and start to wear down and degrade. To measure how much 'effort' the compressor and fan are doing, the currents have to be measured along with to grasp the amperage usage of the compressor and fan. This can give us information on the efficiency of the devices as time goes on. The current measurement for the compressor and the fan will have to do through the power of Ampere's law. In the same manner as transformers, we will use a ferrite toroid to surround the compressor wire and read the current through the induced voltage of the toroid. The induced voltage equation is shown below:

$$V = -\mu * N * A * di/dt$$

μ is the permeability of the air

N is the number of turns
 A is the area of a turn
 di/dt is the rate of change of the instantaneous current

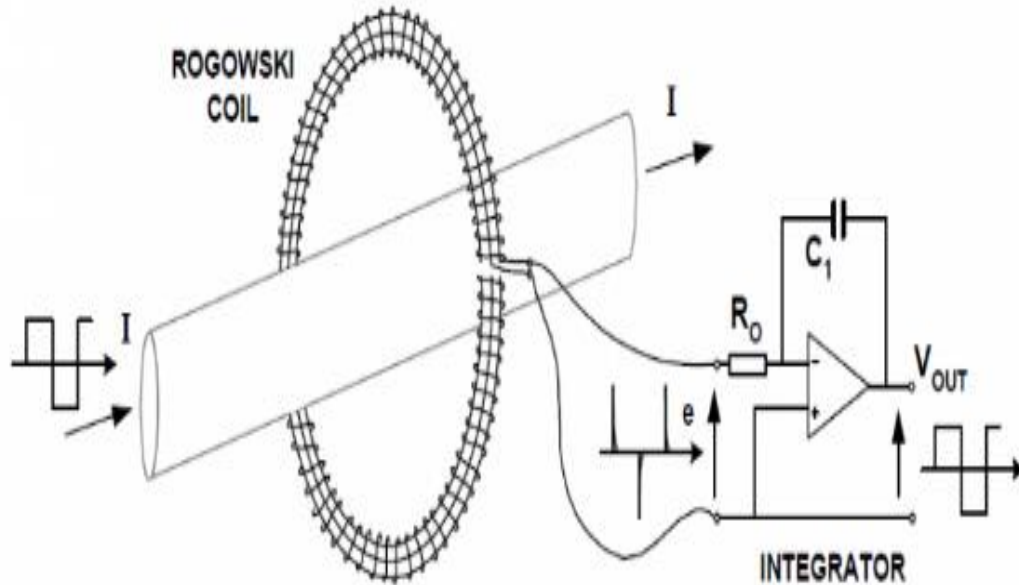

Figure 24 Induced Voltage Diagram (Courtesy of Design Sparks)

This method of reading current through a toroid is called the Rogowski coil and is used to measure high currents in wires by clamping the toroid around the wire. Now will need to integrate the incoming voltage to have or current measurement that we want because of the equation since at the output we see the induced emf and need to solve for i . Current connections should be established on the main power supply and the current and fan wires.

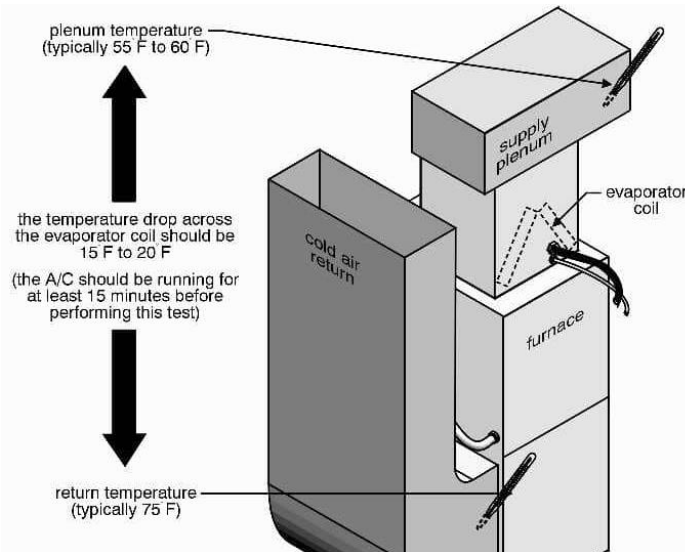

Figure 25 Induced Voltage Points of Measurement (Courtesy of Design Sparks)

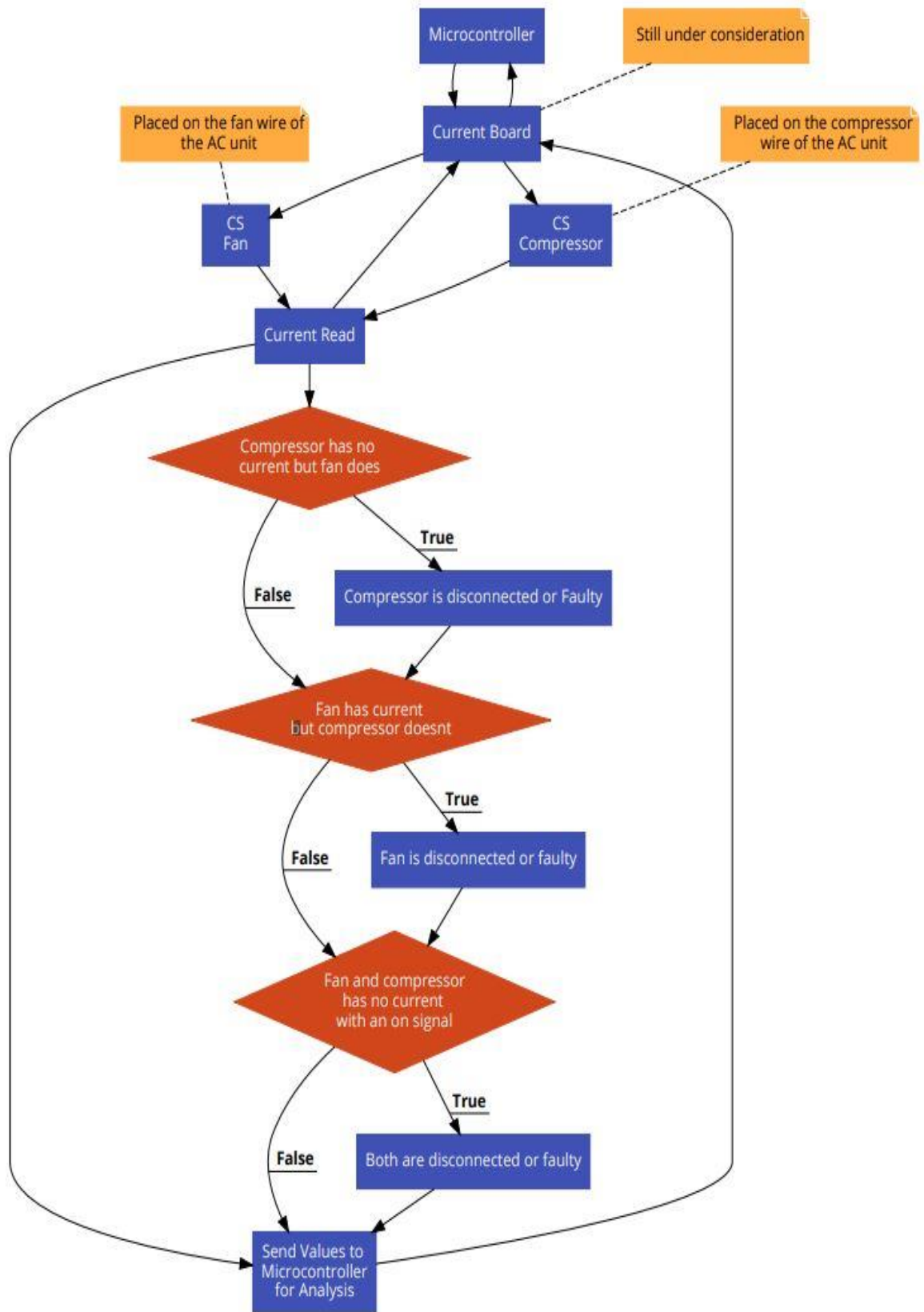

Figure 26 Current Reading Flow Diagram

3.3.4.4 Airflow Sensors

Airflow is an important factor to consider when monitoring the health of the AC unit. If we know the delta T of the return and supply temperatures, the BTU and the square footage, then we can calculate the necessary CFM (or airflow) of the AC unit. Also, at this stage, there is still a consideration to calculate airflow through the temperature sensing the ducts and calibrating at certain conditions but if that were the case then a simple fixture that detects air flow would suffice.

The airflow sensors on the market are expensive and are worth investing in making a cheap mechanical fixture like an anemometer to gather the same data. The rotation can either be detected through the rotation of the pegs on the metal rod or through a magnet attached to one peg and a detector reading the passing magnet to count rotation. There will then need to be a timer to count how many revolutions per second the duct is blowing air at.

3.3.5 Communication Protocols

In the AC unit, there will be a compressor and fan operating at a high voltage and current setting. Due to this high energy operation, there will be high electrical emissions coming from these sources that can pose a problem when sensors wish to talk to the main board and vice versa. Therefore, we will need to have a communication standard that can have high immunity to EMIs in the unit.

3.3.5.1 RS-485

The RS-485 protocol is a great standard to use because of its robust capability to transmit data through high noisy environments and is well suited for this kind of project.

The RS-485 standard is a derivative from other standards already implemented and works by having two wires as a bus line named A and B. The driver as shown in figure A, will send the bit data at the custom voltage level (usually greater than 3 volts) through terminal B and will also send the inverted logic across the A terminal.

The wires then sent through a twisted pair configuration and picked up at the receiver. The receiver will take the differential of the two signals and interpret the signs difference as a one or a zero with respect to A (V_{ab}).

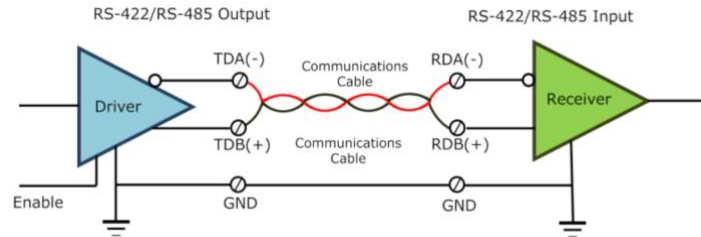

Figure 27 RS-485 Protocol (Courtesy of BB SmartWorks)

The communication is asynchronous and will have to have its own timing schematic for communication order. For instance, the 'Master' will send a command to the slave address that it wants to talk to. The slave will then have to respond back to the master adhering to its request. However, these drivers and receivers have a transmit and receive pins to differentiate what time does the device listen or respond. The following diagrams illustrate this procedure:

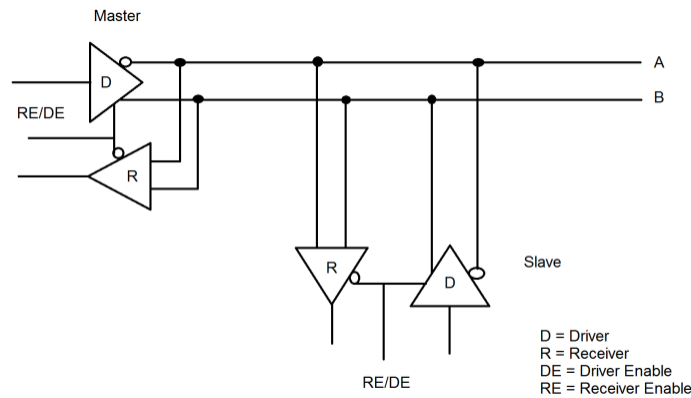

Figure 28 RS-485 Driver and Receiver Data Flow Diagram 1 (Courtesy of BB SmartWorks)

The RE/DE pins will either make the device 'drive' (transmit) or 'receive' data. The flow of data according to the enable pins will look as follows:

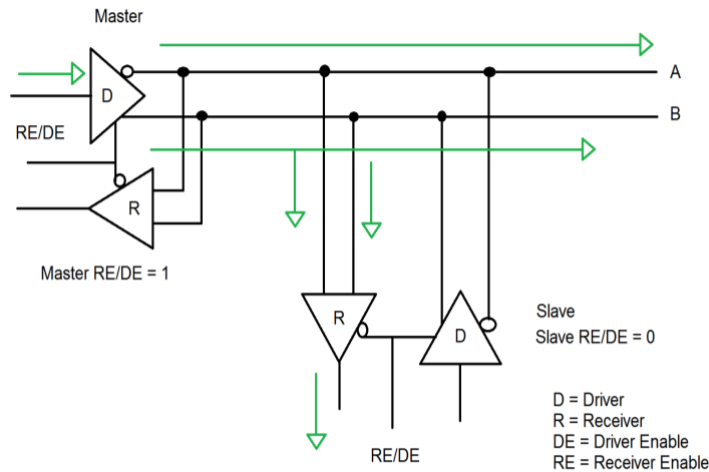

Figure 29 RS-485 Driver and Receiver Data Flow Diagram 2 (Courtesy of BB SmartWorks)

The master device will send a request with the appropriate address device. The key here is that the receiver of the master is at high impedance and will not participate at all the A and B bus lines. This logic is the same for the driver on the slave side.

However, the driver has to be enabled for the master and the receiver has to be enabled for the slave. The data will flow from the master to the bus and then to the slave. When the slave hears the request, the slave will turn to the driver and the master will turn into the receiver. Then the flow will be reversed, and the request data will transmit from slave to bus to master.

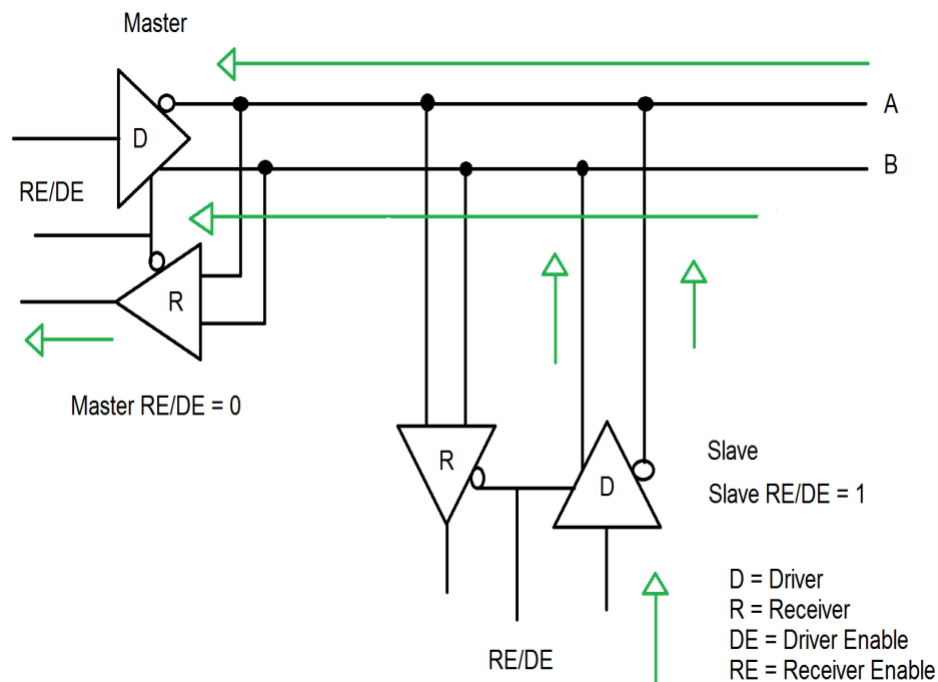

Figure 30 RS-485 Driver and Receiver Data Flow Diagram 3 (Courtesy of BB SmartWorks)

The important consideration to tackle is timing in this structure. This standard is asynchronous and will need to have a protocol in place to manage that timing. The wire standard is the CAT 5 cable as recommended for the RS-485 standard. This comes with pairs of twisted pair wires that all come enclosed in a shielded insulator. The last issue from this communication standard is that the topology of the RS-485 bus is a daisy chain.

The star topology cannot work as the slaves need to be next to the A and B bus lines to have no significant reflections from the bus. This would mean that the connections to the main board serially will have to all be connected through one daisy-chained input.

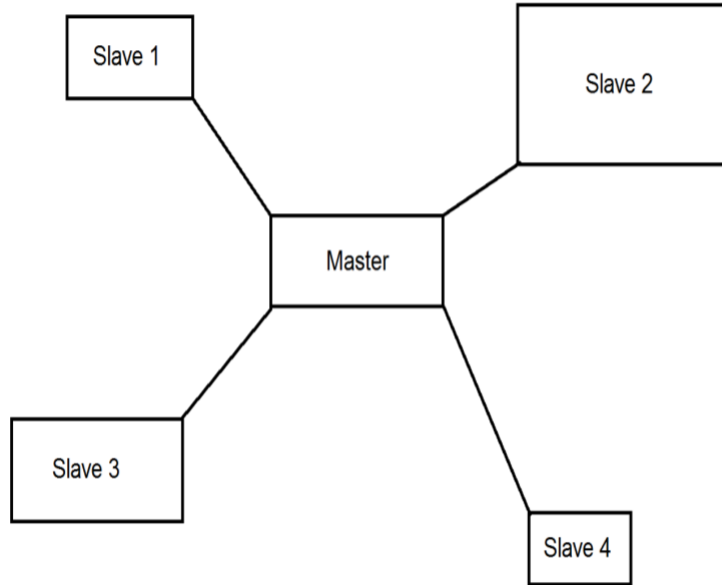

Figure 31 Master-Slave Star Topology (Courtesy of BB SmartWorks)

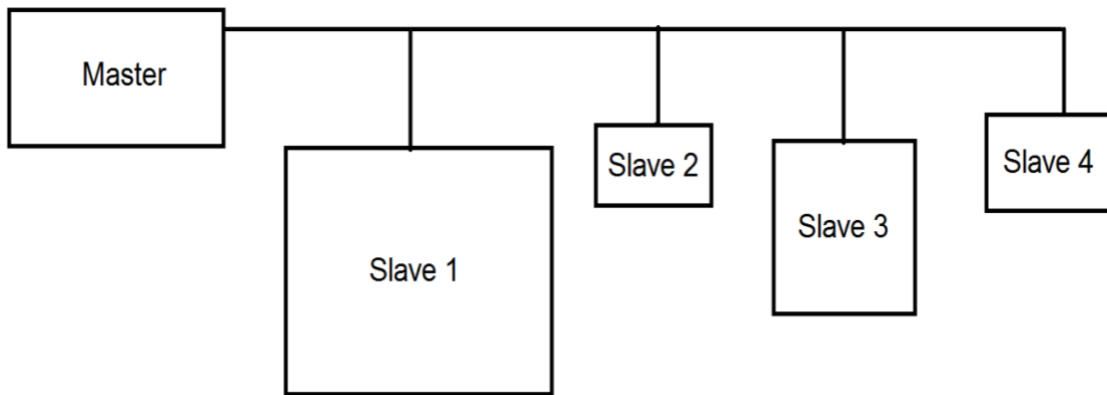

Figure 32 Master-Slave Bus Topology (Courtesy of BB SmartWorks)

However, a solution to have a star like a topology where the inputs can stretch to greater lengths would be to have repeaters that can output RS-485 communication on each output of the main board. Now various daisy chains can be implemented on the inputs.

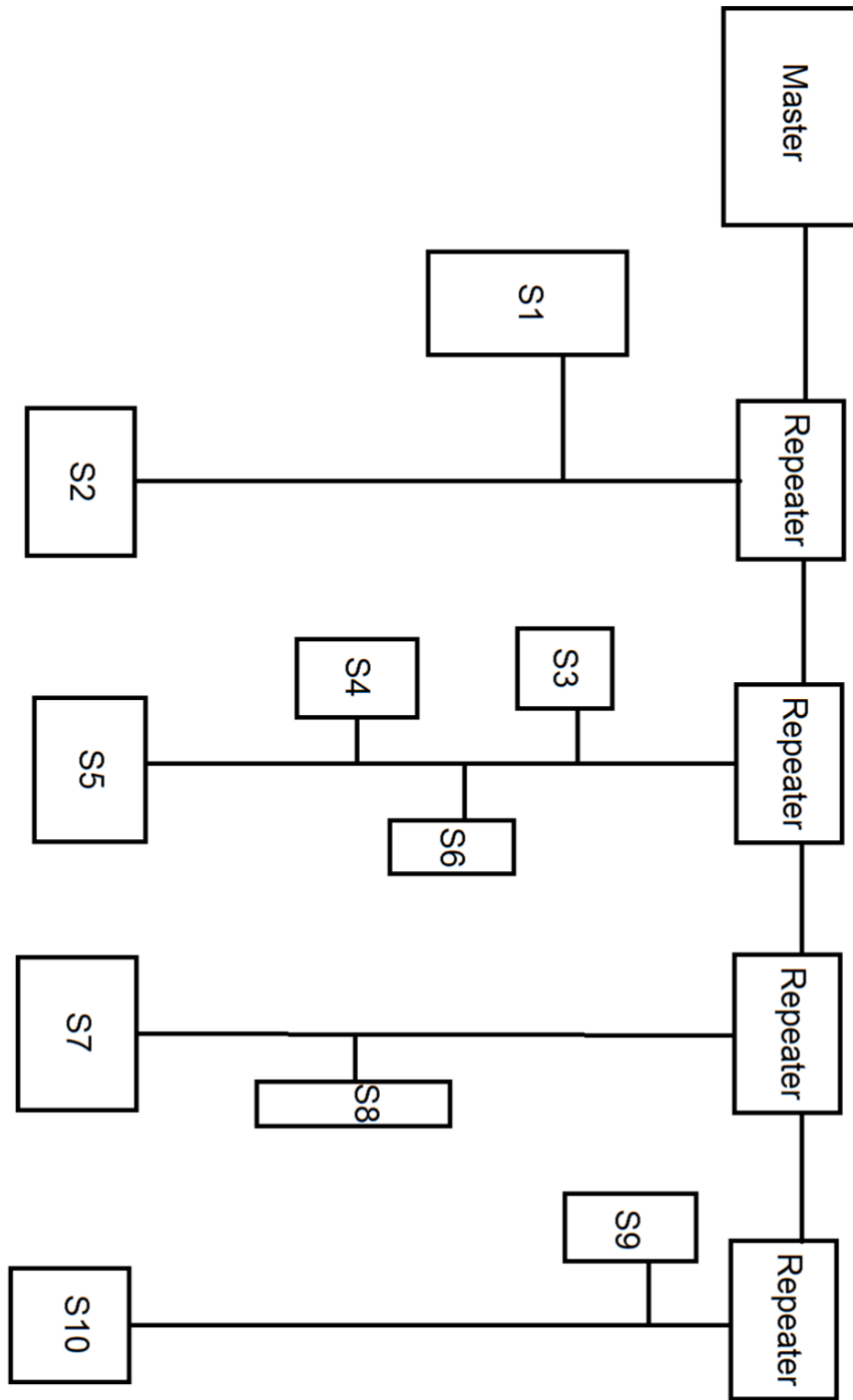

Figure 33 Master-Slave Daisy Chain Topology (Courtesy of BB SmartWorks)

The RS485 is also a great use for this application since temperature readings will not have to take excessively fast since temperature doesn't change too drastically in the cycle of the AC unit.

The block diagram of the communication devices is shown in the figure below:

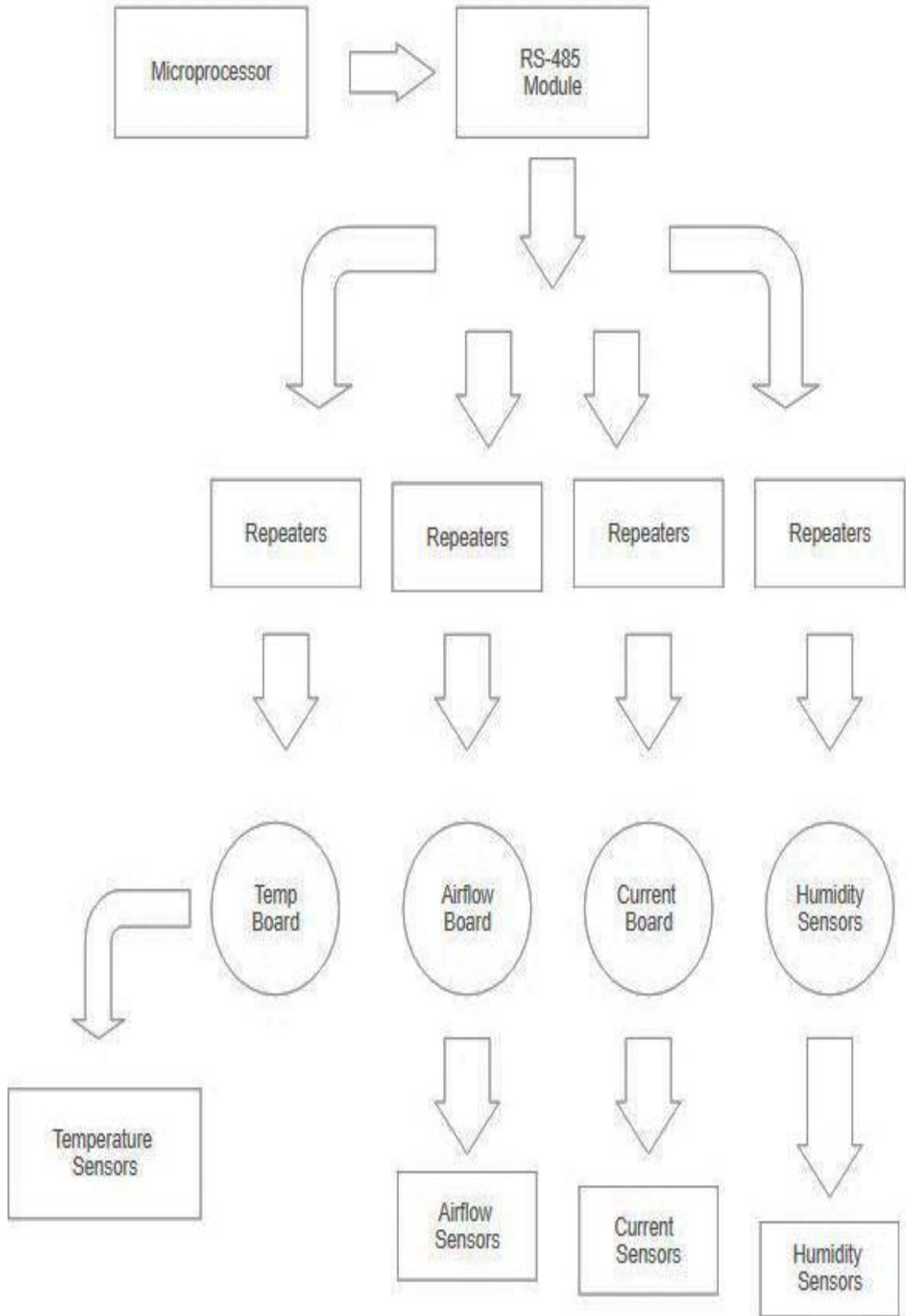

Figure 34 Sensors Flow Diagram

3.3.5.2 UART

The protocol we are going to use to communicate between the boards is UART. This protocol is flexible enough, it is easy to implement and meets the needs for our project. We will design the packet that will be sent between the boards. We are going to have six different packets, request, acknowledge, ready, data, finish, and a reset. When we send data the frame size will be 1 Byte length.

The total packet will be 12 bits, includes the start bit, the data bit, parity bit, and the stop bit. Since we are planning to do parity check, we be applying the even style check. When using the even check all bits that are 1 in the data frame have to add up to an even number to pass the check. The baud rate needs to be specified as part of the UART protocol. Although, there are many baud rates, the standard one is 9600. This allows to send 9600 bits/second and since each of the packet is 12 bits that mean that 800 packets can be send per second. This baud rate provides us more than enough transmission bits to be send in sec for each of the sensors.

3.3.5.3 I2C

To facilitate the control and management of the sensors we plan to use I2C between sensors and the microprocessor. If the sensor is already a chip, like perhaps the ambient temperature sensor, then the data will already be digital and be transferred to the microprocessor I2C bus. Otherwise, there will be an analog to digital converter, like the airflow meter.

3.3.7 The Server or Cloud

The information from the sensors will be processed by the microcontroller to accurately store and display them to the users/clients. The storage will be achieved through the use of a cloud platform/web server, and the display will take place on the devices. The two considered cloud systems to be used are shown below:

3.3.7.1 Google Cloud Platform:

GCP is a web host of cloud services created by Google that provides public access over the internet. Those services also include big data, storage, machine learning, etc.



Figure 35 Google Cloud Platform Map (Courtesy of GCP)

3.3.7.2 Amazon Web Services:

AWS is a low-cost platform created by Amazon that offers the Elastic Compute Cloud (EC2) service that allows to scale up and down services in minutes. It offers a variety of cloud-based products such as storage, mobile, and databases.

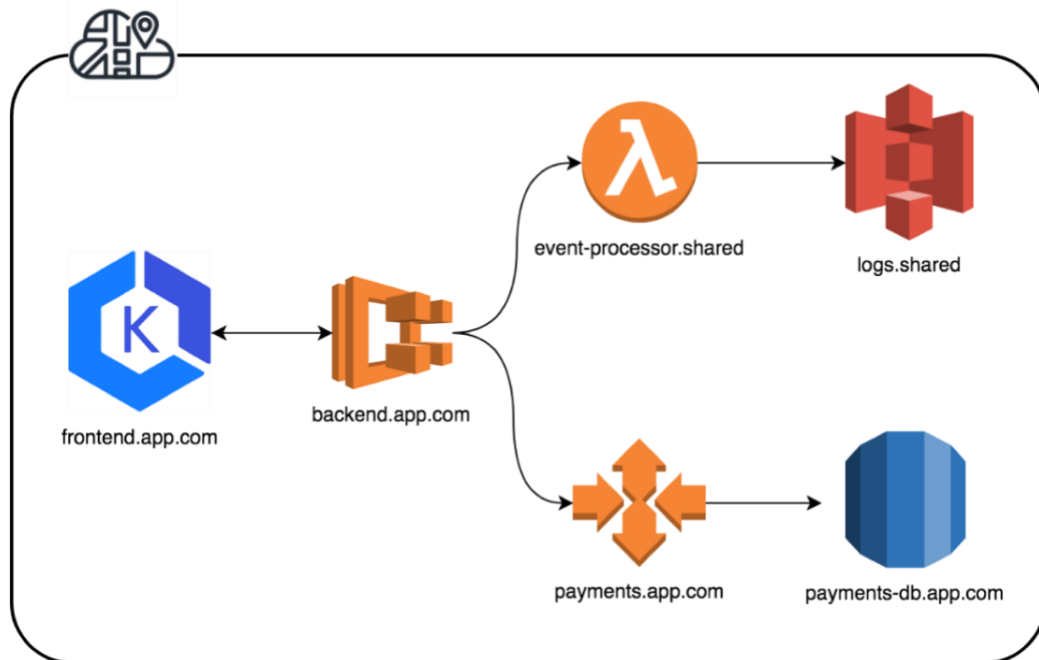

Figure 36 Amazon Web Services Map (Courtesy of AWS)

3.3.7.3 Comparison and Their Selection

The table below some major points of comparison between the Google Cloud Platform and the Amazon Web Server cloud systems:

Table 5 Cloud Services Comparison Table

Specification	GCP	AWS
Price Models	On demand – sustained use	On demand, reserved, spot
Charging	Per minute	Per hour – rounded up
Load Balancing	Cloud Load Balancer, Instance Groups	Elastic Load Balancing, Auto Scaling
Object based storage	Cloud Storage Buckets	S3 (Buckets), Simple Storage Service
Database options	MySQL, PostgreSQL, Cloud Datastore, Cloud BigTable, Cloud Spanner, YugaByte DB (Cassandra, Redis & PostgreSQL), Firestore	SQL, MySQL, PostgreSQL, Oracle, MariaDB, DynamoDB, Neptune
Firewall options	Google Cloud Platform Firewall Rules (part of VPC's), Cloud Armor (Beta), IP Deny/Allow List (Beta)	Web Application Firewall, AWS Shield (DDOS), Firewall Manager, Security Groups
Regions / Zones	18 Regions and 55 Availability Zones Availability	21 Regions and 60 Availability Zones (AZ's)
Developer Tools		
Storage	Google Cloud Storage	Simple Storage Services
Computation Auto Scaling	No	Yes
Longer Subscription	No	Yes
Dedicated Server	No	Yes

Based on the table above, Table XXX, we have concluded that Amazon Web Service (AWS) is the best fit for the purpose of this project. However, we need to still understand how to effectively use it in the project (to know the different services or configurations).

The first question we came across for the use of Amazon Web Services was regarding the right region for our project. Regions are geographically self-contained areas that contains all the required resources for an application, such as computation and storage. AWS has several global regions, we needed to analyze four important factors: latency, legal, restrictions, price, and services availability. When it came to latency, we had to understand where our potential customers are located. The closer to the Region, in which we are running our application, our customers are located, the closer the speed of light. Consequently, they will have a high speed.

Nevertheless, same services in different Regions may have different prices according to the financial situations and taxes laws of the cities/countries they are located. Sometimes the closest Region to our customers may be the most expensive. Thus, if price is more important than customers' speed, or we are allowed to balance both, then choosing a Region that is close and cheap enough for the project is a wiser choice. Since RV Intelligent is based only on the United State for the best of our knowledge, and in this project is latency-critical, we will use the North Virginia Region.

3.3.8 The Web Application and Its Selection

We went with the web application because it will not require the user to download anything to their system. This will provide us with the same functionality than writing a mobile app minus the publishing and updating the app. Updates are done on the server side we no need of user intervention. All that is need is a web browser and the can be supported on any system that have Bluetooth.

3.4 Possible Architectures and Related Diagrams

The first architecture we come up with was much simpler than the one we have decided to implement. This alternative architecture only uses a mobile application. That application cannot be used in other types of systems, such as a computer. The microcontroller unit would only connect with the mobile app, via Bluetooth, and the cellphone application is the responsible to use the database, a SQL database, for storage and authentication purposes.

Moreover, there is only one microcontroller unit, and all of the sensors connect to the same board as the MCU. Since lesser connection are needed, the protocols and communication mechanism are much simpler. Also, the mobile application is only meant to display the health of the system but does not offer the flexibility for the user to access past data or manage them. The following figure, Figure 36, is the block diagram of this alternative system:

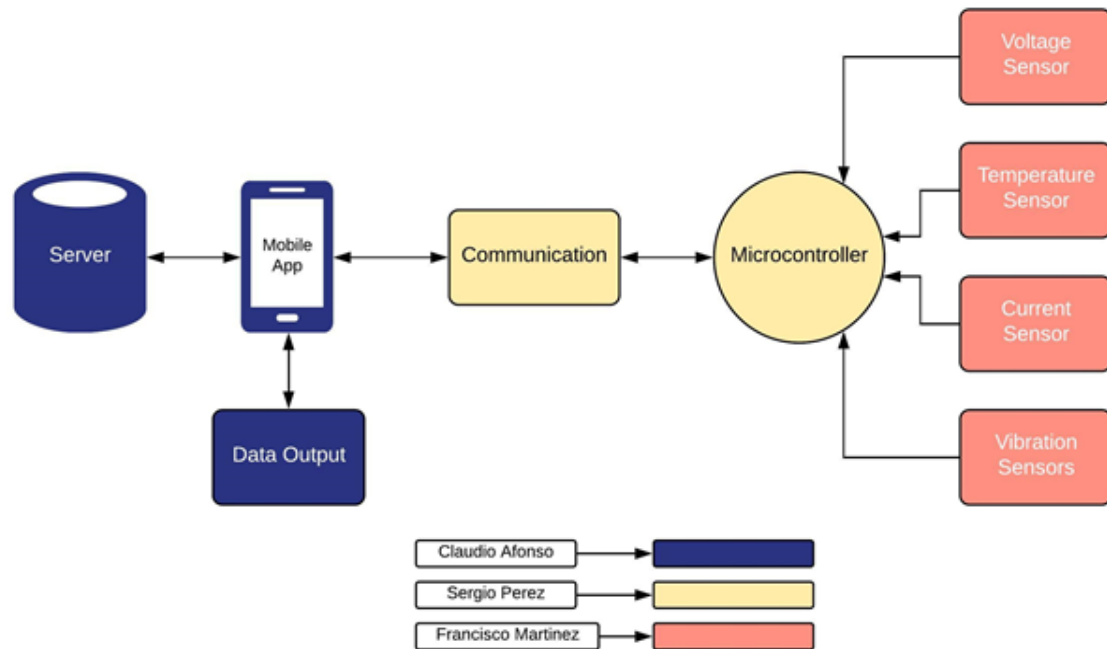

Figure 37 Alternative Design Block Diagram

3.5 Parts Selection Summary

This section will provide a brief summary of the final selection of the parts that are being used to build this project.

3.5.1 All Selections and Costs

For the temperature sensors, there came two options to mind to implement and gather data to the board. The first option was to have one board in completeness that connects to an external temperature sensor and is long enough to be placed on the specified locations. The other option is to make a separate board that will communicate wirelessly and has the temperature board attached to the location specified. This is also advantageous since we can also place other humidity sensors right next to the temperature sensors and have readings for both. In regard to the second option, a big point to consider is that the AC unit is a very noisy environment thank to the electrical emissions of the fan and the compressor.

Therefore, wireless communication would be a difficult system to implement inside the unit. The underlying reason to implement a wired system is the fact that the AC unit is compact all the critical points are in nearby proximity to each other. We searched for temperature sensors and found some that also have humidity sensors designed on the chip as well. The disadvantage to this would be that it would be placed on the coils and not make contact to the coils themselves if assumed that the board will be in an enclosure for the customer. Therefore, there must be an extended temperature sensor capable of reaching places the board can't. Thermocouples could be used and placed on the board with an instrumentation

amplifier. Thermocouples are expensive however compared to the second option. There are remote and local sensing boards that have temperature sensing on the chip and uses a BJT to measure external temperature.

Below are the price comparisons:

Table 6 Temperature Sensors Price Comparison Table

Component	Price	Range
Thermocouple DFR0198	\$8.20	-55C to 125C
MAX31850	\$6.45	
TMP431ADGKT	\$0.93	Up to 150C
BJT 2N396	\$0.19	-55C to 125C

The cost in total to implement a thermocouple alone is substantially higher than installing a PCB part that can read temperature both locally and extend out to read temperature elsewhere in hard to reach places. There were certain parts to look at comparing remote/local temperature sensing chips. For instance, there was the TMP431 TI chip and the microchip. Both have the same capability and use of a BJT to read external temperature.

Table 7 Temperature Sensing Chips Price Comparison Table

Component	Price	Range	Functionality	Number of sensors
MIC384	\$1.52	-65C to 150C	I2C capability and interrupt threshold temperatures.	2
TMP431	\$0.93	Up to 150C	I2C capability, interrupt and reverse polarity alert on BJT.	1

Here the MIC384 seems to be the better choice since the two of them have the same function and purpose but the TM431 has only one port for external temperature sensing. However, the TM431 was chosen mostly because if there was an error due to negligence of the installation of the BJT, we would know due to the functionality of the interrupt of the TMP431 chip. That way we would know the data coming from the remote sensor is incorrect. So even if having another chip would mean double the price, the functionality of the TMP431 is an important one to have in this application.

For the main board, it is advantageous to have a temperature sensor there for calibration of the remote temperature sensors. Having a sensor there would mean having two points of reference for the remote temperature sensor: one on the sensor board and another on the main board itself. Since the placement of the main board will be centralized in the AC unit, humidity can be sensed too in

conjunction of temperature. This idea will be paramount in deciding the part to use for the humidity sensor.

Table 8 Humidity Sensors Price Comparison Table

Component	Price	Output	Accuracy	Range
HIH-5030	\$5.95	Analog	+/-3% RH	0-100%
HS1101LF	\$6.46	Capacitance	+/-2% RH	1-99%
SI7006	\$2.04	I2C	+/-5% RH	0-90%
SHT30	\$3.67	I2C	+/-3% RH	0-100%

The analog humidity sensors are more expensive and are but are more accurate compared to the digital sensors. For the SHT30, it is more accurate and has a greater range of relative humidity compared to the Silicon Lab component. It is more expensive, however, for a small increase in part price the accuracy could be spared. The humidity sensor could be either, further research can be obtained to further select the component part.

The airflow sensor will be a simple analog to digital converter since the motion of the fan induced by the flow of the duct will conduct a current to flow. The ADC used will be the one already implemented on the PSoC microcontroller.

As mentioned earlier, we will need to be able to read current going through the compressors along with the voltage to obtain the power factor analysis. Between two methods of achieving this, we chose either using a clamp to read the induced voltage or reading the current directly in series with the current. The second option will allow us to directly probe and see how the current behaves in accordance with the compressor and fan.

The majority of the sensors researched and found curtailed to our needs was from the company Allegro. The current usage for most RV systems go between 30A to 50A, however this pertains to the whole system usage of the AC lines. To read the current going into the compressor, a lower rating of amperage can be used. If the total current of the system is to be measured, then the specifications needed is to be able to measure the max current of 50A.

The major components found for current sensors were mostly from Allegro but there were some other competitors as well. An issue that occurred while finding and researching parts for this section was that a component was chosen but later found to not be in stock and obsolete. Greater care was taken afterward for each part.

The following table, Table 9, will show the price comparison:

Table 9 Current Sensors Price Comparison Table

Component	Price	Output	Status	Max Rating
ACS71020	\$5.26	I2C	N/A	90A
ACS720	\$5.69	I2C	Active	65A
CQ2065	\$7.82	Analog	Active	50A

The part chosen at first was the ACS71020 but will be replaced by the ACS720 IC chip instead. This way we are 15A above our maximum specification.

Accelerometers on Digikey spread from piezo materials and movement switches. Compared to IC accelerometers, the analog pieces were more expensive than the ICs. The main component used in this design that was chosen is the BMA253. The part is a good fit for the project since the board in practice will be placed on the compressor to monitor the vibration. There are other accelerometers at a cheaper price and have the same function, however, this part was chosen specifically because the sponsor has the part already in stock and has been used before in previous designs.

However, it is still subject to change. This is because we strive to find, if possible, better ways, in terms of price and simplicity, to achieve the vibration reading. As mentioned before, reading the vibration of the system is really critical, due to the fact that the AC system is inside an RV. Therefore, we plan to accomplish the less vibration as possible by empowering the user to know when the vibration caused by the AC system is above normal. We are currently doing more research on the vibration sensor.

Please refer to the table below, Table 10:

Table 10 Vibration Sensors Price Comparison Table

Component	Price	Output	Sensitivity	Range
BMA253	\$2.05	I2C	1024 (+/-2g) to 128 (+/-16g)	+/-2g, 4g,8g,16g
KXTJ3	\$1.69	I2C	1024 (+/-2g) to 128 (+/-16g)	+/-2g, 4g,8g,16g
1005447-1	\$5.58	Analog	200mV/g	

3.5.3 Bill of Materials

Following are some of the materials we were able to acquire. In that table, Table 11, the unit and total prices, according to the component quantities are shown. However, the AC system and mount we will use for demonstration is not yet completed.

Table 11 Bill of Materials

Quantity	Part	Price Per Unit	Total Part Price
1	CYBLE-222005-00 PSoC 4 BLE	\$13.53	\$13.53
2	CY8C4125AXI-483 PSoC 4	\$3.72	\$7.44
4	RS- 485 module SN65LBC176DR	\$2.77	11.08
6	Micro USB port	\$1.13	\$6.78
1	Accelerometer	\$2.05	\$2.05
1	thermocouple	\$1.07	\$1.07
2	Humidity and ambient temperature	\$2.25	\$4.50
6	RGB LED	\$0.92	\$5.52
2	4 pin header dip switch	\$2.86	\$5.72
6	Power Switch	\$1.55	\$9.30
2	Terminal Block 6 pos	\$6.49	\$12.98
1	Flash 4Mb	\$0.87	\$0.87
1	TI Level shifter	\$0.48	\$0.48
	Total		\$81.32

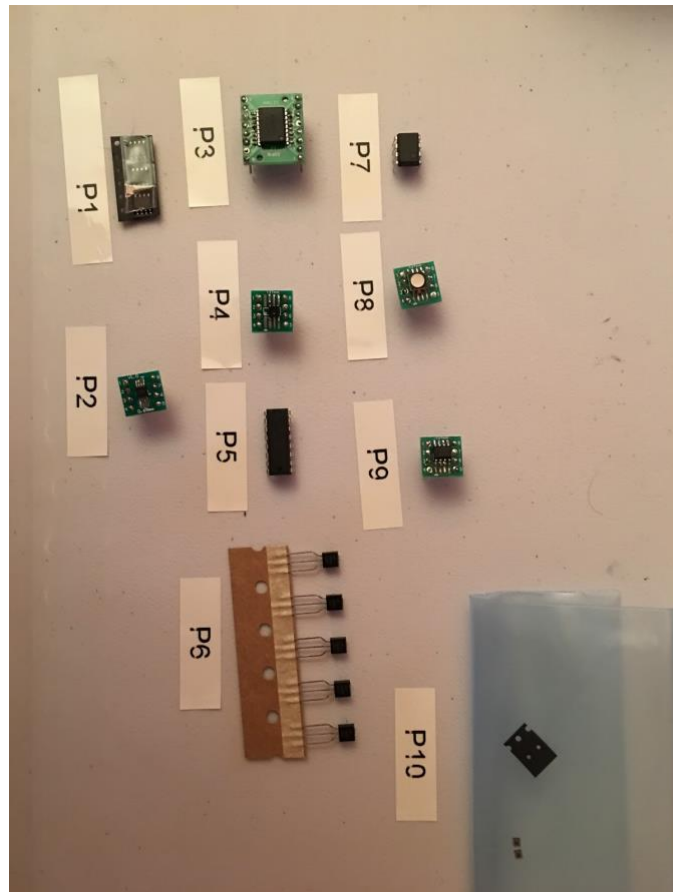

Figure 38 Materials Received

Table 12 List of Parts Received

Designator	Part Name	Part Number
P1	High Side Relays	BTS50301EJAXUMA1
P2	Temperature Sensor	TMP431ADGKT
P3	Current Sensor	ACS724KMATR-65AB-T
P4	Temperature/Humidity Sensor	SI7006-A20-IM
P5	Voltage Level Shifter	CD4504BE
P6	External BJT for Temperature Sensor TMP431	2N3906-AP
P7	RS-485 Module	SN75LBC176AP
P8	RGB LED	QBLP679E-RGB
P9	4M Flash Memory	SST25VF040B
P10	Accelerometer	BMA400

4. Related Standards and Realistic Design Constraints

In this section we will go over standards that related to the design of our project as well as constraints that could impact the design of the SmartRVac device. Below we describe the constraints that could impact our sponsor needs and the constraints from the parts vendors that impact us. These include economic, time, social environmental, political, health, manufacturability and sustainability. All of these constraints and standards need to be considered to successfully design and build the device.

4.1 Related Standards

Industry, professionals and students needs to follow standards when designing products. Standards not only helps in provided a common ground when dealing with parts, cables, etc. it can also describe behavior that is not harmful or hazardous to people and the environment. There a several standards our project uses from different standard bodies including IEEE and ANSI. Overall and we will discuss the IEEE 830 and IP Code standards below.

4.1.2 The IEEE 830 Standard

The IEEE 830 is the standard recommended for documenting the software requirements specifications (SRS). this standard helps developers and clients set realistic goals and outlines the timetable for software development. The document goes to start describing what a good SRS contain. Below is a list describing those. Characteristic of a good SRS:

- **Correct:** Correctness can be achieved by having every requirement in the document as one that have been meet on the software.
- **Unambiguous:** Unambiguous can be accomplished by making sure terms and specifications are not open to interpretation by the creators and/or user. Having the document review by a third party is way to find unambiguous since language by nature it is. Also, when using tools to represent parts of the project like UML, use regular language to describe the tools by those unfamiliar with the terms.
- **Complete:** A document is considered complete when “to be determined” (TBD) term is not used unless it is strictly needed. If TBD is used, then it needs be accompanied by a list of conditions that caused it and how to resolve it.
- **Consistent:** To be consistent, the document needs to be uniform. If there is any part that does not concur with any another part of the document, then it is not consistent.
- **Level of importance and or stability:** Understand which feature are essential for desirable and rank the essential features, providing stability to the project. It helps customer to clear any assumptions and specify the requirements they want. For the developer this helps to make correct design decisions and devote the time needed on the different features of the software.

- Verifiable: SRS should only have statements that can be verified by people or machines. If a requirement cannot be tested, then it needs to be revised or removed.
- Modifiable: A document is modifiable when changes are made, and the document is still able to retain its structure and style. Having the requirement separated and not mixed with each other, no redundancy and use indexes, tables of contents that are easily made to apply changes to documents later.
- Traceable: this is achieved if the requirements can be traced to previous stages of development by referencing early entries on the document and future features by using unique names and references by number.

Our group uses the SRS to help us brainstorm and select the right tool for the mobile app. The project is dependent on the mobile app to get data from the hardware through Bluetooth and onto the database. The data will be shown to the user using the mobile app. For this we need to understand the nature of the software, the environment the software will be used in, the characteristics of the software, and the agreement between all parts involved in the development of the software. SRS explains how to achieve these and help us to understand these concepts.

4.1.2 IP Code ANSI/IEC 60529

The IP Code is a standard developed by the International Electrotechnical Commission (IEC) and has been adopted as an American National Standard (ANSI). The IP Code offers a system to classify enclosures for electrical equipment. This enclosure ratings list the degrees of protection for the electrical components by separating into two categories:

1. Protection from foreign objects and protect people from accessing the hazardous parts.
2. The entry of water into the enclosure. These two are the main conditions the standard deals with as well as description of how to test the enclosure.

Our sponsor requires that the enclosure be IP69 rated. The first digit stands for the protection of the electronics from foreign objects including dust. In this case 6 stands that the enclosure is dust tight. The second digit deals with protection from water. The number 9 stands for jet stream/high water pressure protection of the electronics inside the enclosure.

When we design our enclosure, we have to take into consideration the openings for USB data cables, power cord and LEDs on the enclosure. This will require us to make it well insulated at those openings to comply with the standard and pass the certification. We plan to 3D print the part for prototype and testing and before the design is finalized.

4.2 Realistic Design Constraints

In the following section we are going to describe the constraints associate with the development of the SmartRVac. These constraints were identified as we did research and start putting together the requirements for the project. Also, we took in consideration our sponsor needs and what the user will expect from using this product.

4.2.1 Economic and Time constraints

Time constraint impact our projects because of the magnitude of features the system have and need to be build. The hardware part of the project is composed of three different PCB, the main control unit, the sensor board and the thermostat interface board. This require that the group have a good time table to complete all them. We need to have a realist schedule for the design of the boards, account time for the board to be build, and deliver, and time to test and troubleshoot the boards. These can all be affected if the parts to be use become out of stock, delivery times affected by weather and PCB producer taking longer than expected.

In the software side, the project requires the development of the embedded code, web/mobile application, database and server API. The embedded and web/mobile application will take the longest and will need to be developed concurrently to be able to deliver in time. Since we are using a cloud service, the development time for the backend is shorted because of the tools and resources available from the service.

The economic constraints the project have are related to the business side of our sponsor. Since this is product that is intended to be in the market our group is limited on the parts, such as sensors, microprocessors and other that we can buy from distributors including royalties from the part manufacturer. This restriction is applicable to the software licenses.

For this reason, we have to consider different supplier and models for the parts to find the right part for an economical price. Our sponsor is providing us with all the economic needs of the projects. This include buying the parts, development kits for the PSoCs, PCB printing and other tools require for the software and hardware development.

4.2.2 Environmental, Social, and Political constraints

Since the SmartVac is a product intended to be sold in the USA and abroad the restriction of different markets is needed to be taken in consideration. Not meeting a constraint will limit the product introduction in that market and will require to redesign the product to comply.

4.2.2.1 Restrictions of Hazardous Substances (RoHS)

In 2002 the European Union (EU) passed a legislation to restrict the use of hazardous substances in Electrical and Electronic Equipment (EEE). The list of hazardous material included heavy metals, lead, cadmium, and chemicals, hexavalent chromium, polybrominated biphenyls, and Polybrominated diphenyl ether. It stated that by July of 2006 all EEE sold in the EU must pass the RoHS compliance. In 2011 RoHS 2 was implement and in July of 2019 RoHS 3 will enter in effect adding four new chemicals to the list, Bis(2-ethylhexyl) phthalate, Butyl benzyl phthalate, Dibutyl phthalate, and Diisobutyl phthalate.

4.2.2.2 Political

In April 8th, 2018 the USA government put a tariff on certain products and raw materials coming from China. The current tariff stands at %25 from the initial %10 a year ago. This affect the prices and availability of components that we can buy. Several vendors like Digikey are showing a label on the affected components. Another area where the tariff can affect is on the PCB fabrication. The price of fabrication can go up if the company source the materials from China. Although at the moment this does not imposed an impediment to us, it could in the future if the tariff goes up or more parts/resources are added to the list. It can add delays and higher cost that we did not account for and we would have to assess and act with the situation accordingly.

4.2.2.3 Prop 65

The state of California 1986 passed the Safe Drinking Water and Toxic Enforcement Act also known as Prop 65. This law requires warning labels on products that contains chemicals deem to be carcinogen, affect development and reproduction to products sold in California. The act was updated on August 2016 and gave business until August 2018 to comply. On the list of products Electrical cords is one on the list as well as polybrominated biphenyls and Butyl benzyl phthalate chemicals. The warning labels are not required but having the label except the business from the enforcement actions as they are seemed to be complaint. The law except small businesses with 10 or fewer employees from warning requirements.

4.2.3 Health

The product uses the Bluetooth low energy protocol as means of communications. As required by FCC this product cannot cause harmful interference and it must accept any interference. This include such interference that may cause an undesirable operation. Our device has to abide by these rules so in does not interfere with medical devices and medical equipment as well as with first responder equipment. Also, the radiated output power of the Bluetooth module

with the chip antenna is below the FCC radio frequency exposure limits. However, it recommended that we minimize the contact a person could have with the antenna during normal operation of the product. Following these rules and recommendations might make the product not work in all conditions but it will make sure that do harm the user and those around.

4.2.4 Manufacturability and Sustainability constraints

Manufacturability is an important part of bringing a product to life and it goes hand to hand with sustainability. During the design phase is a good idea to think how all the parts that make the product affect the environment, profitability, and the availability of the product in the market. Balancing both require some finesse from the parties involved in the creation of the product. Our project sources most of the parts from manufacturers that have design them following environmental regulations. This minimize the environmental impact leaving only the shipping of the parts from vendors to us. In financial terms shipping cost is an added cost to manufacture and the time it takes for the parts to arrive also can affect this process. The upside of buying the parts as opposed us designing them is that companies already have done the R&D, got the parts certify by the different government agencies like the FCC and they have also taken in consideration the manufacturability and sustainability of their products.

Our mission is to design a monitor device for RV A/C systems that is reliable, safe, economical and offer a value to the user. The goal is to inform and alert the user of anomalies on their A/C unit so they can resolve them before it affect other parts of the system that could bring the system down and cost more money to repair. It also provides the user with an idea of when their A/C system will need to be replace based on the current operation of the unit. Our hope is that user feel empowered and becomes proactive dealing with their A/C unit maintenance and less reactive. This way the user will not only save money but also time. Hopefully they will spend more time on the road and less on the shop.

For the sustainability aspect of the project we need an enclosure that is IP69 rated for waterproof/weatherproof and insulate the components from contact. The design of the enclosure will be done in house and 3d printed this way we can minimize cost; shipping time and we can make design changes faster. The construction of SmartRVac will use parts that are commonly available in the market and that price properly, so the product can have a price point that is competitive and reachable to the customer.

5. Project Hardware and Software Design Details

This section will provide details on the design of the system. Similar to the research section, Section 3, those details range from web application, hardware, database, web server, to communication protocols, decoding and encoding technique design.

5.1 Initial Design Architectures and Related Diagrams

The design presented in the following subsections represent the whole functionality of the system:

5.1.2 Communication Data Paths

From the electrical sensors to the web server or database, this is our plan for sensor data gathering and storage of the AC system project. The first step would be the sensors measuring the data input from the AC unit. Whether the sensor is I2C based or analog, the microprocessor has to be able to read the data in terms of ones and zeroes. The analog inputs must then be converted to digital using an analog to digital converter. The data will then be sent through an I2C bus to a microprocessor that can manage sensor read timing calls. The reason I2C bus is used on this aspect of the device is because I2C is a great standard and protocol to use in PCB and close proximity sensors. I2C is not a great tool to be used on long distance wiring where electromagnetic interference can be superimposed onto the wiring. That is why the RS-485 Standard is used in the communication between the sensors and the main board. The microprocessor will have its own embedded UART protocol to drive the RS-485 module whenever the main microprocessor is asking for data.

In this standard, we are able to connect many boards to the RS-485 Bus and communicate directly to the board that the microprocessor asks for. This entails that each board has the capability to read the RS-485 signals coming from the main microprocessor's RS-485 module. The board will collect the data and begin the process of sending the data to the server. The microcontroller will be able to read and output the control signals that connect to the thermostat through relays depending on the information on ambient temperature and user configuration. The microcontroller will send the data points to the Bluetooth module through its own standard UART lines. Since the Bluetooth module will be connected to the PCB or integrated in the PSoC module, the UART communication is fine since the traces will be short to enhance reliability. This will not be a worry with the PSoC since it already has a built-in module but will still need those UART lines for communication. The data sent through the Bluetooth module will reach the mobile device user application. That application will be responsible to transmit the data to the server for storage and statistical computation purposes through a TCP/IP connection using FTP. When the calculations are properly completed and stored, they will be sent to the mobile application to be displayed to the user through the

same connection type. The following diagram, Figure 38, will give a more precise idea of the whole data flow process:

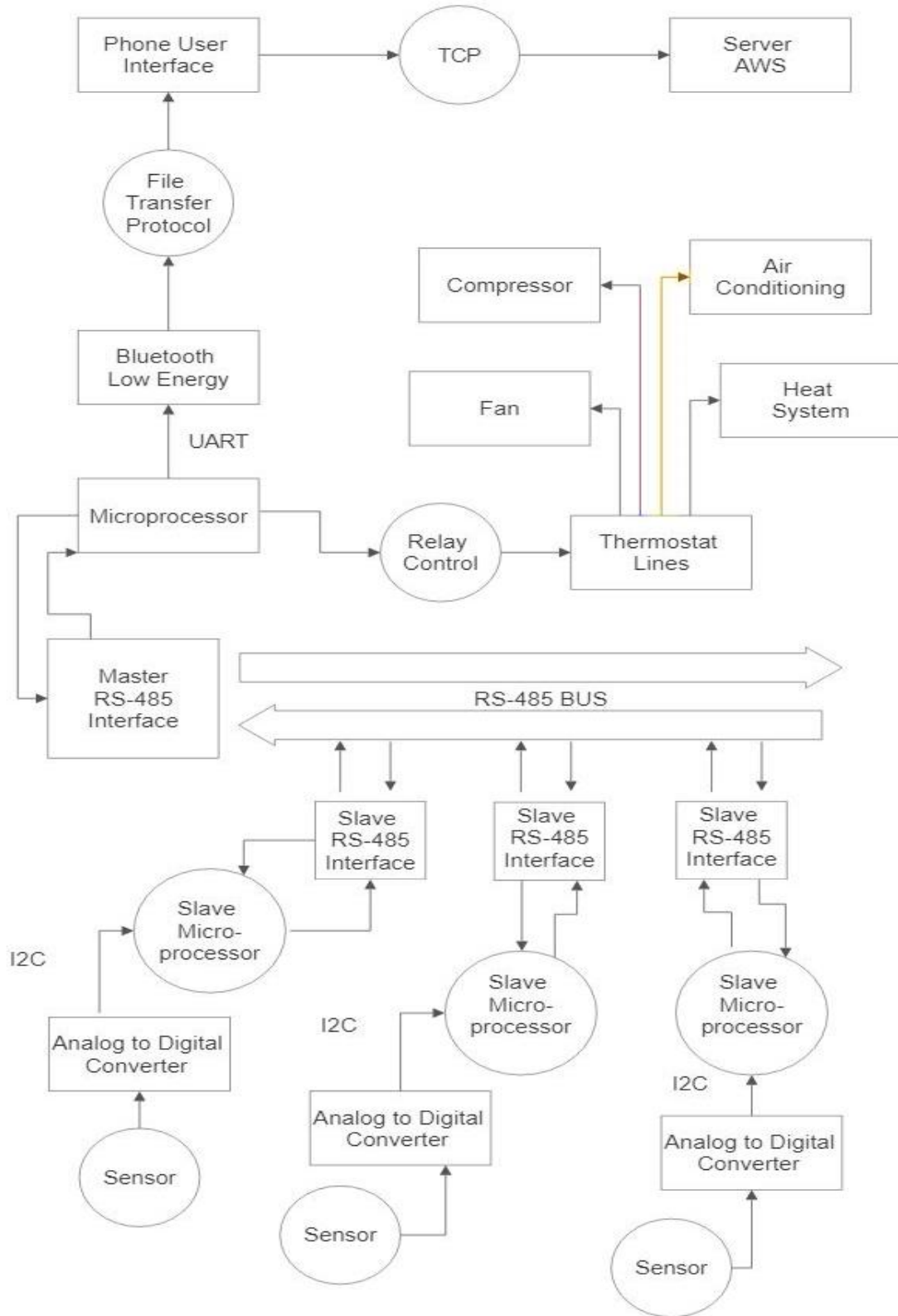

Figure 39 System Data Flow Diagram

5.1.2.1 Sensor Communications

When the packets are received from the sensors it needs to be processed on the board. First the data needs to be stripped off the start, parity and stop bits. Once the data from a sensor is received, either of these two things can happen: the reading is timestamp and saved for later transmission, or the data is part of values needed for a calculation. An example would be when the air pressure of two sensors are used at different points on the expansion valve and the data received from both are use in equation to get the differential air pressure. Once the calculation is done the result is time stamped and saved. An option that we are considering is to use a Json file where the sensor data and timestamp is recorded. This way all the data can be stored for long periods of time if the Bluetooth connection is not available and all the data can be formatted by sensor type in a compact file.

If the sensor is already a chip, like perhaps the ambient temperature sensor, then the data will already be digital and be transferred to the microcontroller I2C bus. Otherwise, there will be an analog to digital converter, like the airflow meter. The RS-485 block will then take that data from the microcontroller through its output pin and straight to the driver line. The serial data will have its own bit-rate depending on the software program protocol implemented. Since the microcontroller can have precise timing ability it will be able to send that data according to a specified baud rate. The baud rate chosen for the communication line is 9600. The microcontroller, of course, will only send data if the main board asks for it. The main board will follow the same protocol when sending a request to the bus line. The RS-485 was chosen for its reliability even in heavy electromagnetic interference environments and its ability to connect to many devices on the bus line. The bus line will have two signals where the differential voltage from the two will give the digital signal on the receiving line of the module.

There is no specified protocol for the RS-485 and therefore must be implemented by our own standards of protocoling the data packets. In the next couple of diagrams will be the code flow diagrams describing visually how the code will send data and return data. First will be an overview of how the microprocessor will run through the sensors. Since there is not enough space to fit all the diagrams, some sections will be described as functions and will be shown in detail afterwards. As the overview of data gathering, the microprocessor will run through all the sensors one by one to gather their data elements. The data gathering flow is shown in the diagram afterwards and is shown here as a function to illustrate the microprocessors routine. For each error received, there will be a recorded history for all sensor errors. After all the data is gathered, the organized data will have its corresponding tag to delineate what type of sensor data it is and will be processed to be packaged sent through the Bluetooth module.

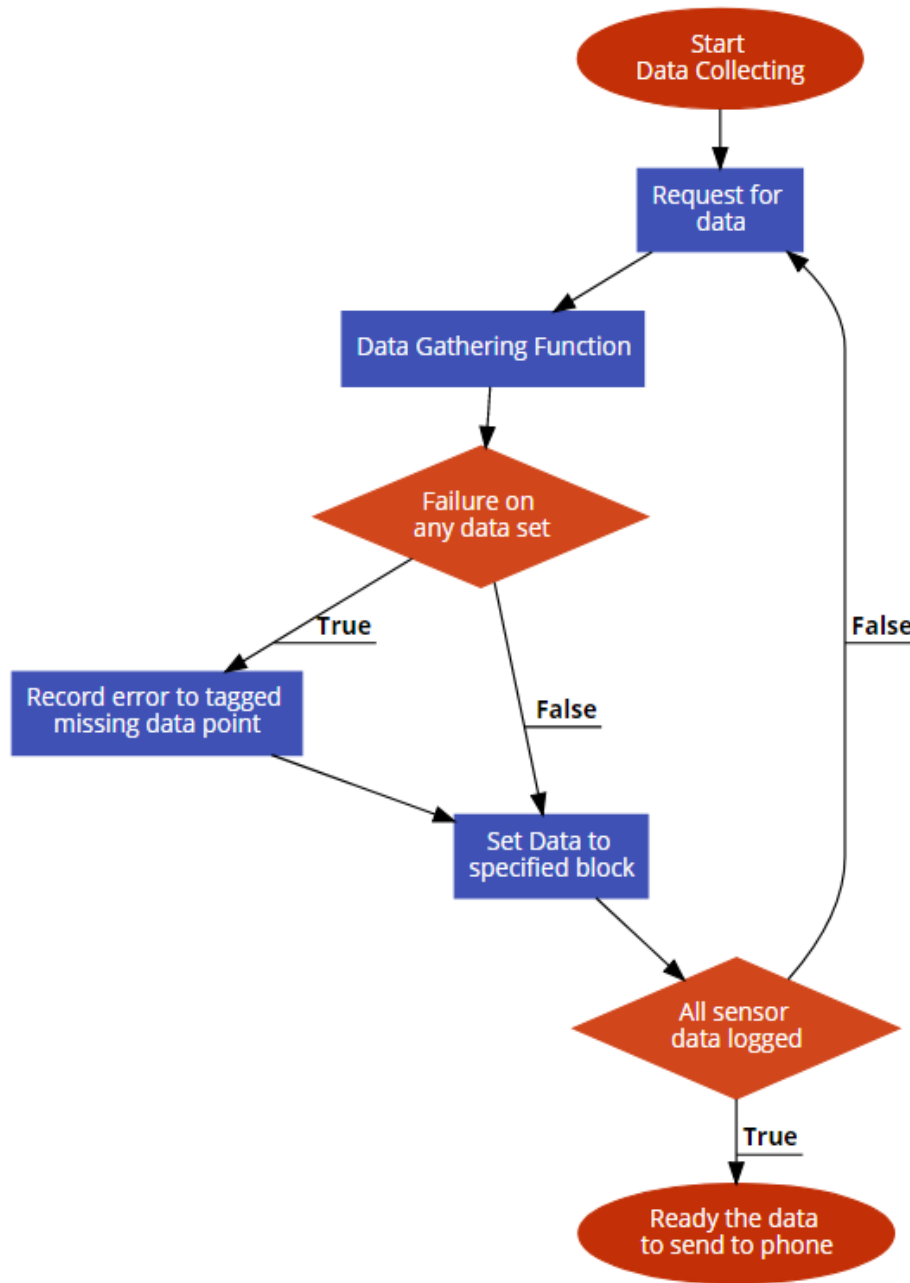

Figure 40 Sensing Data Flow Diagram

The data gathering for the code will start off with the request by the master with the start bit heading first and the address to the sensor board will be next, followed by the error checks. The sensor board will hear the request by the master and will respond with the data packet to the master. If there is an error where the sensor does not respond, the master will try again for a certain number of times until it gives up and moves on. This includes the error checks. If there is an error, the master will resend request. The master will take note of the errors tagging along who failed and what retries were needed to get an answer or correct data packet.

Table 13 String of Data Format

1 Start Bit	Address	ACK bits	Data Request	1 Even Parity Bit	2 Stop Bits
-------------	---------	----------	--------------	-------------------	-------------

The modules RS-485 module standard is produced in such a way that both devices are listening to each other first. Only until the master or the interrupt from the sensor board will it take a hold of the line. The code flow for this is separated from the other flow since this is an interrupt pin and will only take a hold of the line if the sensor board's threshold is set.

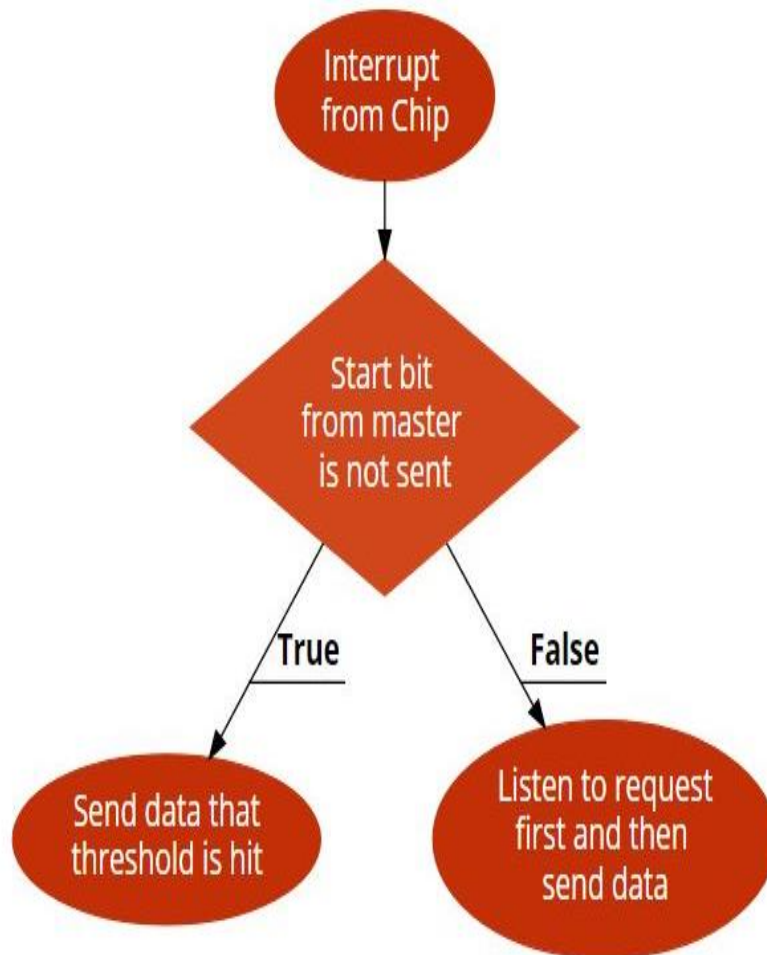

Figure 41 Interrupt Diagram

If our protocol was implemented this would error check: the parity bit when set as even only checks the data request part of the packet. This is done by counting how many bits equal 1s in the data request section and if it is an even number then the parity check pass. When parity check does not pass, the data is corrupt, and a new request should be sent. The following diagram shown the process:

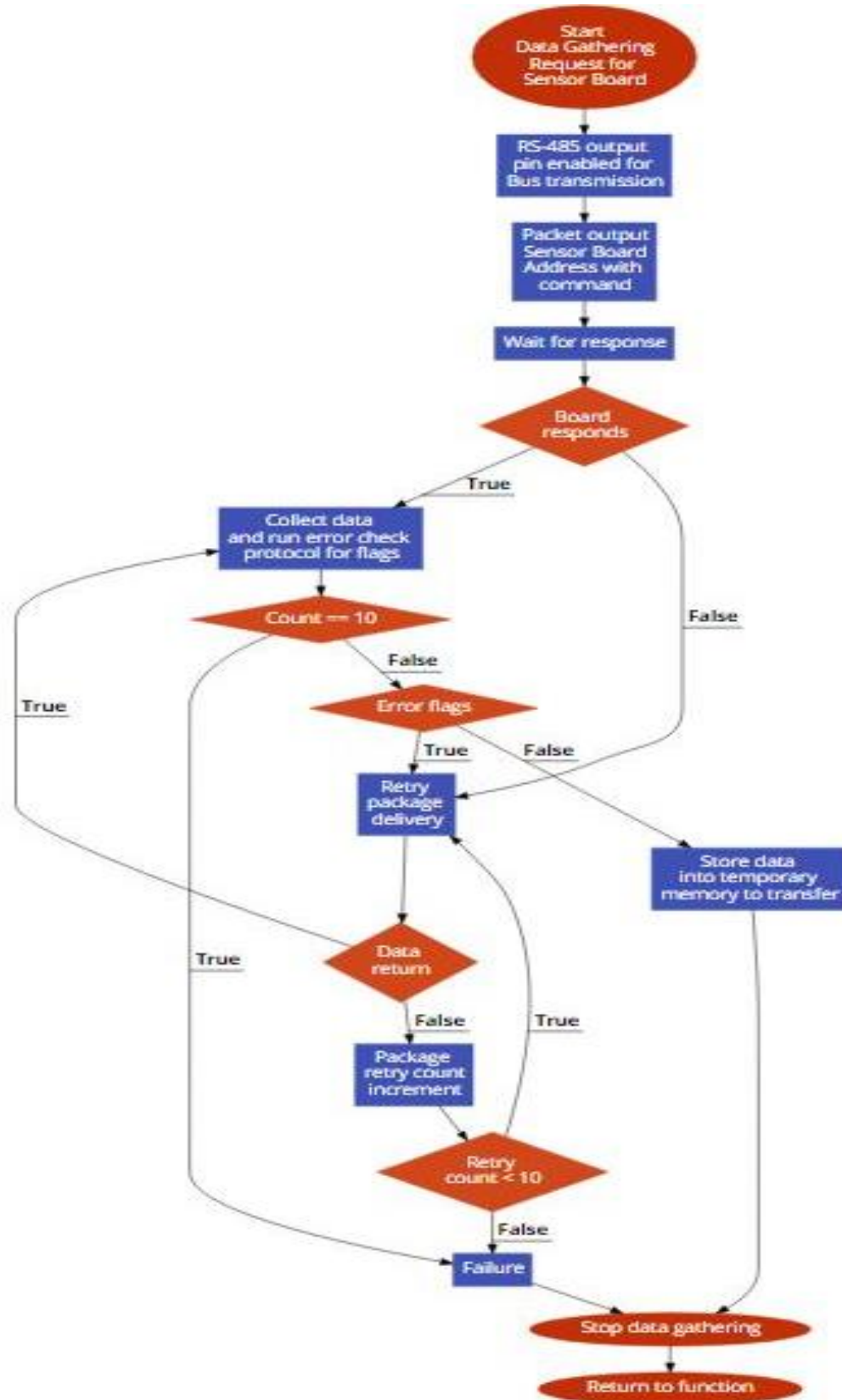

Figure 42 Sensor Data Bits Flow Diagram

The sensor board will have its own code in order to know what the request data will be and when the micro will call for a sleep function. The board will hear the microprocessors request and will first scan to see if the address is its own. If it is, it will start to process the request and perform whatever the request is and ignore the request. The board will still need to listen after transmission of data.

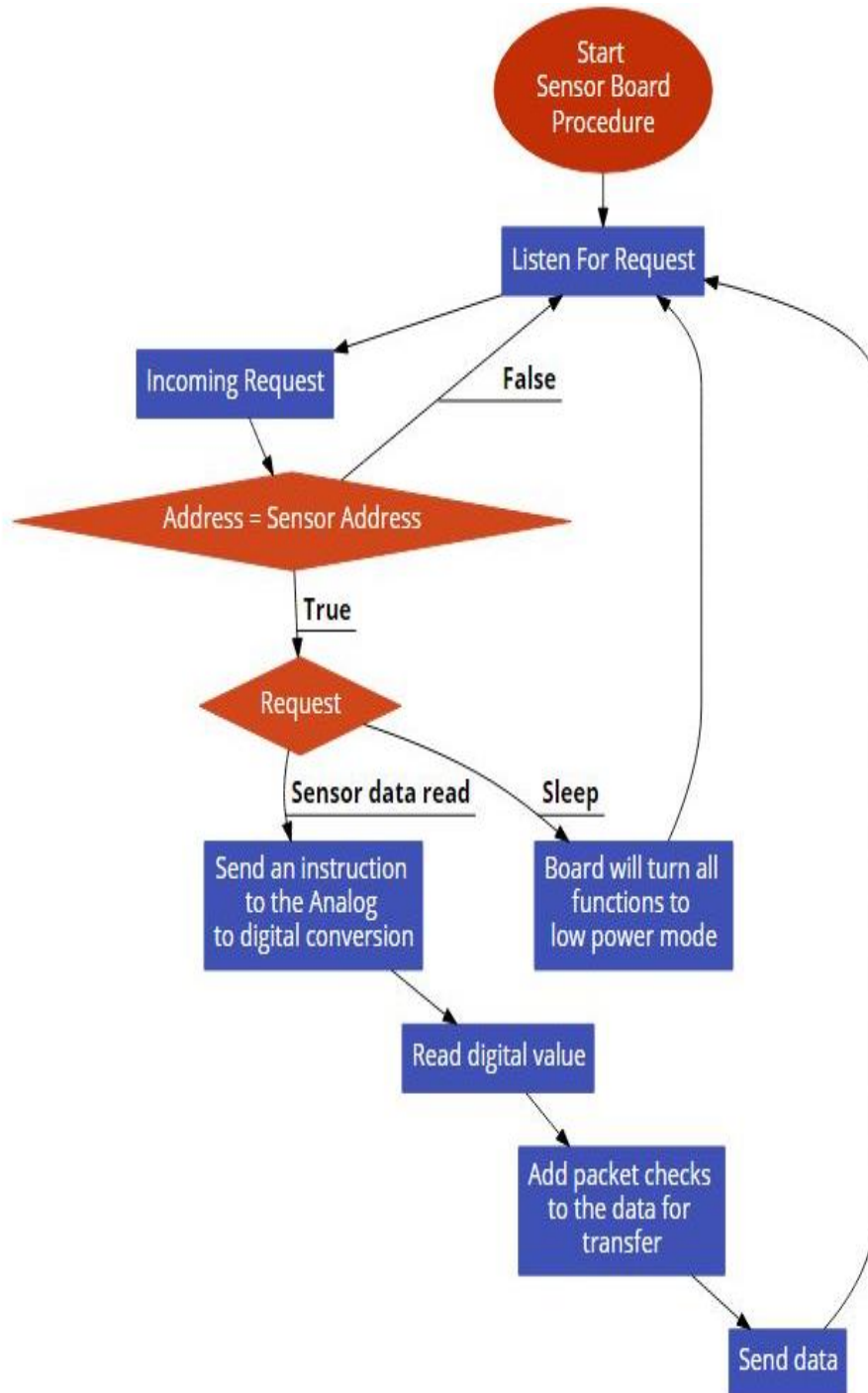

Figure 43 Sensor Listening Flow Diagram

5.1.2.1.1 RS-485 with UART Protocol

The microcontroller will send out a request and all the sensors boards will receive the request. The request will have four bits that will be treat it as an address. Using 4 bits lets up to sixteen devices listening to the microcontroller. Once the sensor listening for that address receive it then sends the data packet to the microcontroller. All the other sensors who listened to that address and do not match the address sent ignore the microcontroller. This way we can prevent collision and all the sensor talking at the same time.

Since UART is the protocol it will be use, the expected package from sensor follows the convention of the packet frame. The out of the 9 bits size we can use our data frame will use 8 bits or one Byte. This will let send a char or int 8_t per packet.

The baud rate needs to be specified as part of the UART protocol. Although, there are many baud rate the standard one is 9600. This let's send 9600 bits/second and if each packet is 10 bits that mean that 960 packets can be send per second. The packet frame we plan to use will be 10 or 12 bits depending if we use parity check or not. In case we use parity check it will be the even style check where all bits that are 1 in the data frame have to add up to an even number to pass the check. The tables below show the two types packets we can use. Before the microcontroller can make another request to the sensors it will wait two clock cycles. This way we can make sure the sensor has finish sending packets.

Table 14 12 Bits Packet

1 start bit	8 data bits	1 parity bit (even)	2 stop bits
-------------	-------------	---------------------	-------------

Table 15 10 Bits Packet

1 start bit	8 data bits	1 stop bit
-------------	-------------	------------

5.1.2.2 Microcontroller Signals to the Thermostat

The main processing will be contingent on the state that the AC unit is turned on or not. If the AC unit is on, then the microcontroller will be in sleep mode. The thermostat has around six major line wires that house the transformer power, fan and compressor lines, heat pumps, ground, and heat and air conditioning control lines. Here relays can be implemented to control the operation of the AC unit depending on the input from the user. With the inclusion of the thermostat, the diagnostic device will have control and knowledge of when and where the AC unit starts, on and off cycles, etc. The GPIO pins on the microcontroller can serve the

purpose of communication control here for the power lines for turning on the AC unit.

5.1.2.3 Cellphone and MCU Communication/Block Structure

The device uses the Bluetooth Low Energy (BLE) protocol to communicate in a bidirectional way with the smartphone. When the smartphone is in range of the device, data start transmitting from the device. When the smartphone is not in range the device MCU will send the command to the BLE module to keep listening for the smartphone. Once in range, the connect is resume and data flow can continue.

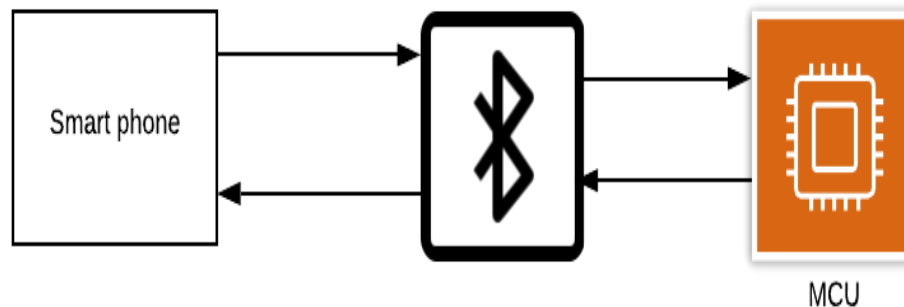

Figure 44 Cellphone and MCU Communication/Block Structure

The microcontroller device should be the master when the Bluetooth connection is established. This is due to the fact that BLE requires the devices to be either master or slaves, but not both. Since the master would enter in sleep mode whenever there are no active connections until a slave's connection inquiry is recorded, it is convenient to have the mobile device as the slave because it is easier for the user to start a connection form its UI. When using BLE the first step is to establish a connection. Every time they are in a range the microcontroller starts the data transfer. The Json file containing the collected data from the sensors, it is sent to the mobile app using the File Transfer Protocol (FTP). Once the transmission is successful and the file data is erased and ready to start recording new data.

5.1.2.4 Server and MCU Communication/Block Structure

The MCU can communicate to the server thru the internet using Wi-Fi network. This route should only be used when the connection cannot be established. The MCU sends sensor data and the server sends a confirmation of the data transmission. This check is used to send the next package or to resend the package. Also, when the MCU wants to initiate a session it waits for confirmation before starts sending data.

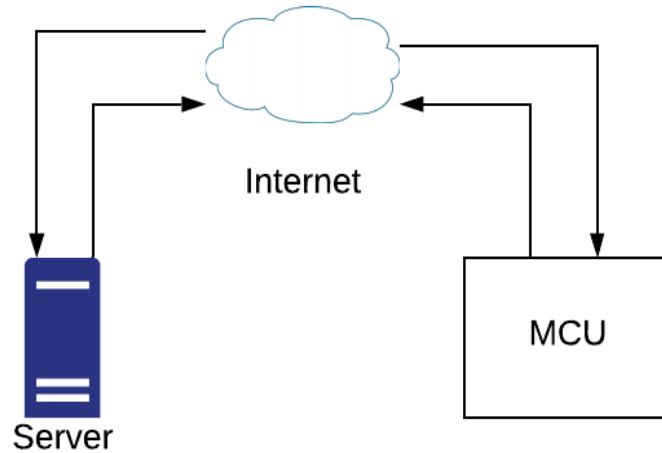

Figure 45 Server and MCU Communication/Block Structure

5.1.2.5 Server and Cellphone Communication/Block Structure

The phone will connect to the server thru the internet using the cellular or Wi-Fi network available. The data received from the MCU will be processed at the server and sent to be displayed on the cellphone. The server also handles the authentication of the user to database.

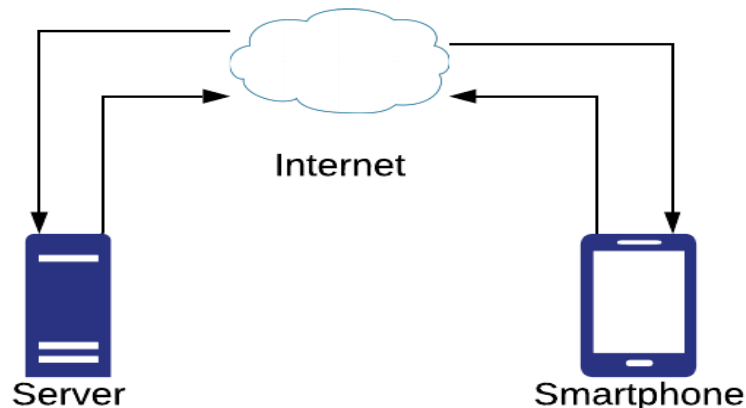

Figure 46 Server and Cellphone Communication/Block Structure

5.1.2.6 Server and Database Communication/Block Structure

The server communicates with the database and pass the information in this case to the cellphone. When the server receives a request from the cellphone to retrieve or store data, the server perform security checks to prevent injections and other related attacks. Depending on the cloud provider architecture the communication to the database is handle thru the internet if the database is offsite or intranet when the database is onsite.

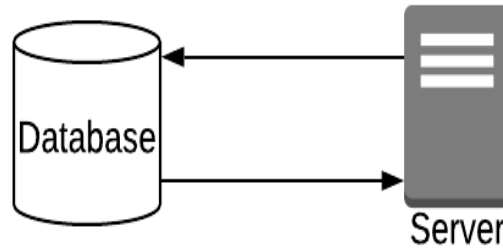

Figure 47 Server and Database Communication/Block Structure

5.1.2.7 Full Communication Topology/Block Structure

The block diagram below shows the data path from the MCU to the database. As in the previous diagram if the Bluetooth route is not available the MCU uses the Wi-Fi route to communicate with the server.

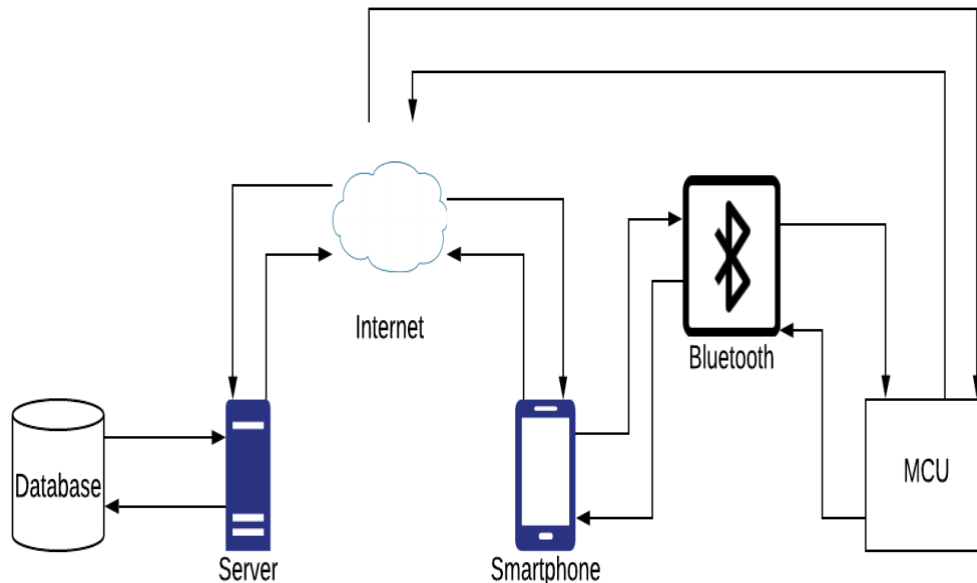

Figure 48 Full Communication Topology/Block Structure

5.2 First Subsystem, Breadboard Test, and Schematics

The first subsystem is the main board. This board is used for the main processing, packaging, and instruction commands for the rest of the system. This acts as the central hub station. The microprocessor will communicate with the sensor boards, thermostat interface board and the phone application the user interfaces with. The block diagram below explains this relationship and responsibilities the microcontroller has.

This explanation is to help understand the schematic of the main board better. The microprocessor communicates with the sensor and thermostat interface boards through the RS-485 module and to the phone with the internal Bluetooth technology. The schematic has sub schematics which were done to minimize space and confusion on the board.

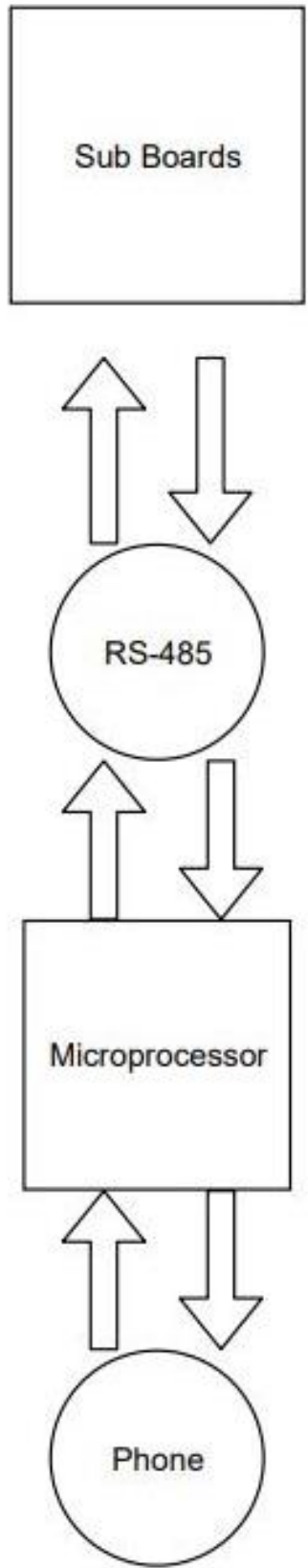

Figure 49 First Subsystem (Main Board) Block Diagram

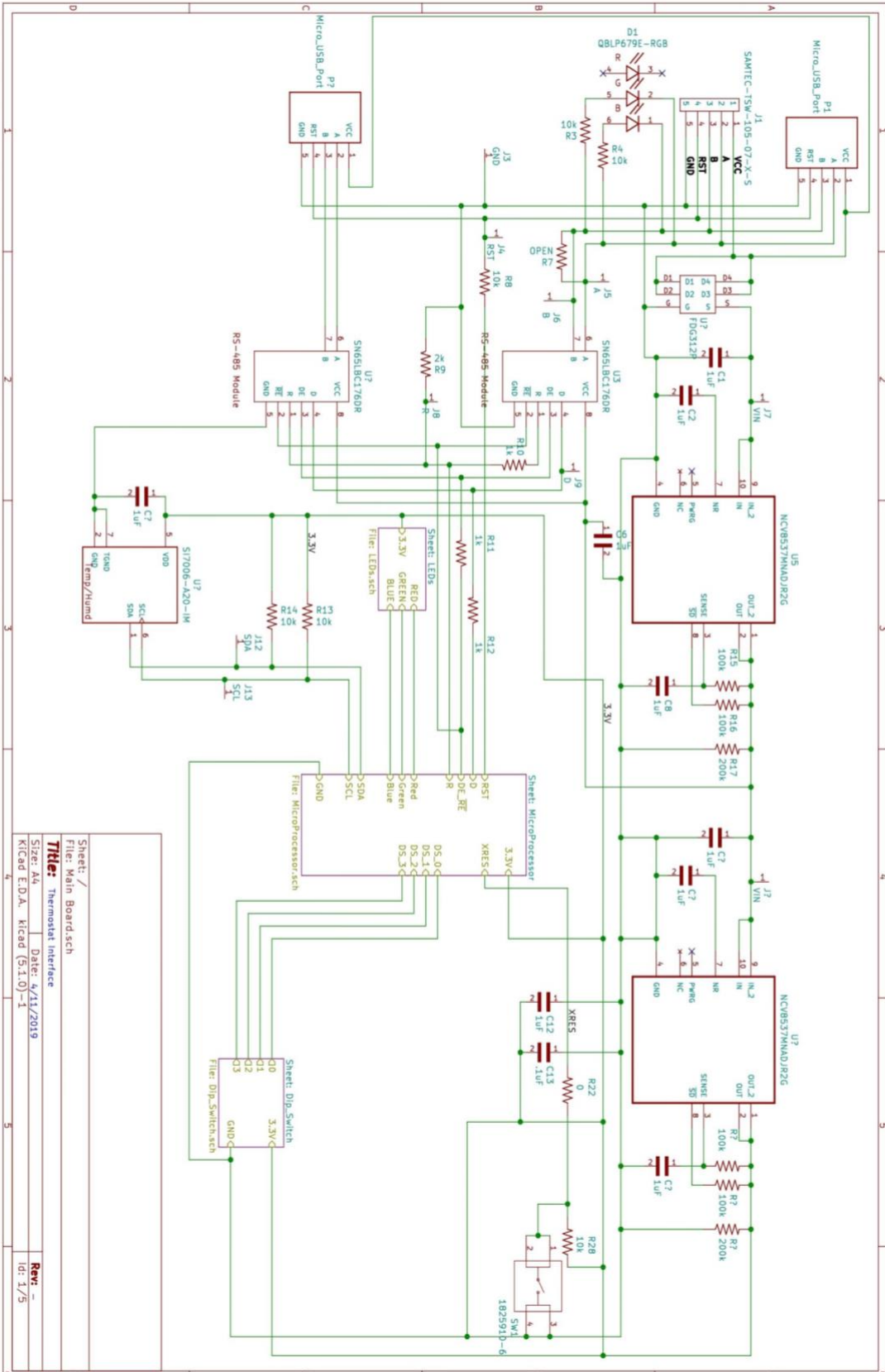

Figure 50 First Subsystem (Main Board) Schematic Part 1

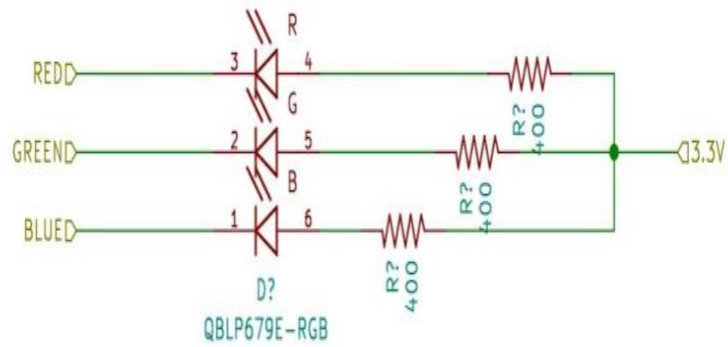

Figure 51 First Subsystem (Main Board) Schematic Part 2

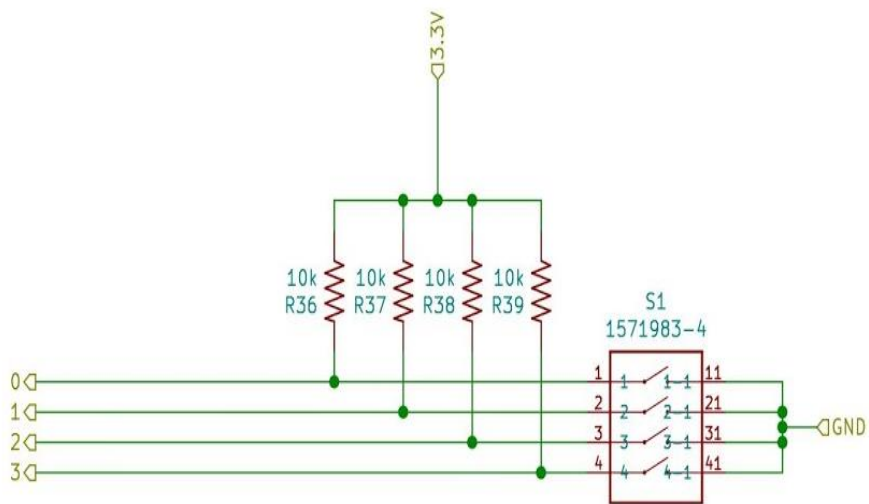

Figure 52 First Subsystem (Main Board) Schematic Part 3

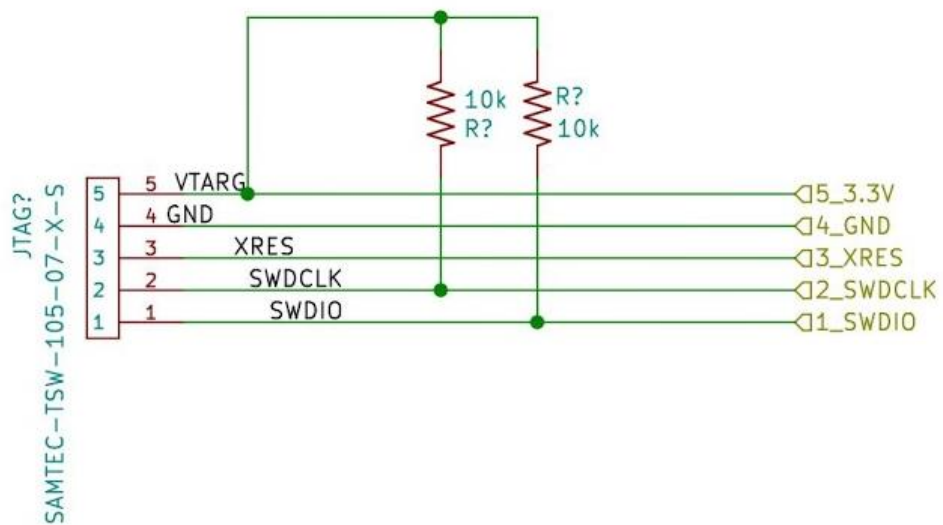

Figure 53 First Subsystem (Main Board) Schematic Part 4

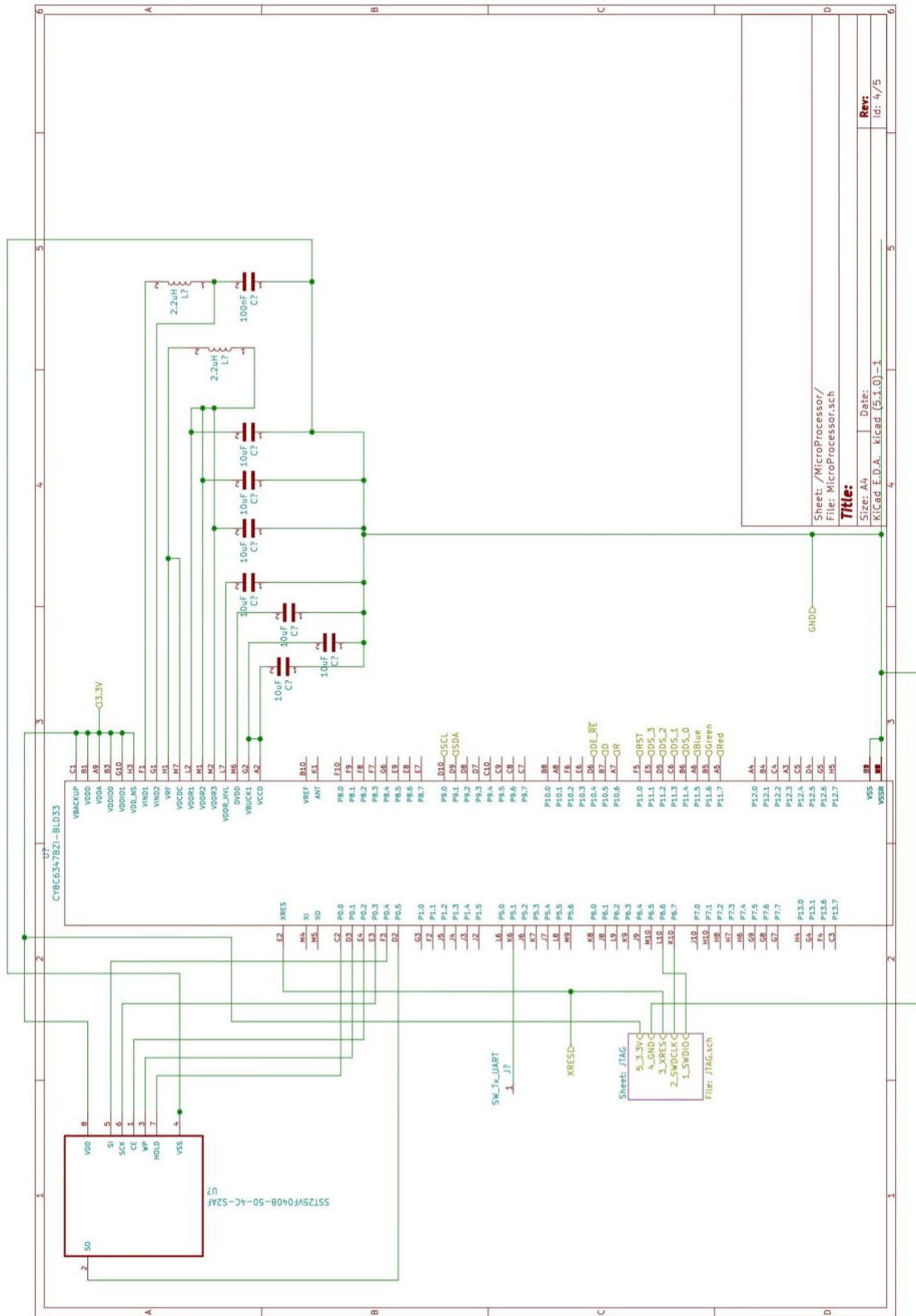

Figure 54 First Subsystem (Main Board) Schematic Part 5

5.3 Second Subsystem, Breadboard Test, and Schematics

The second subsystem is the sensors board. This board is used to gather data from its attached and internal sensors positioned on the board to the microprocessor. The board's own microprocessor will listen for communication sent from the main processor and begin executing data gathering through I2C on its own board.

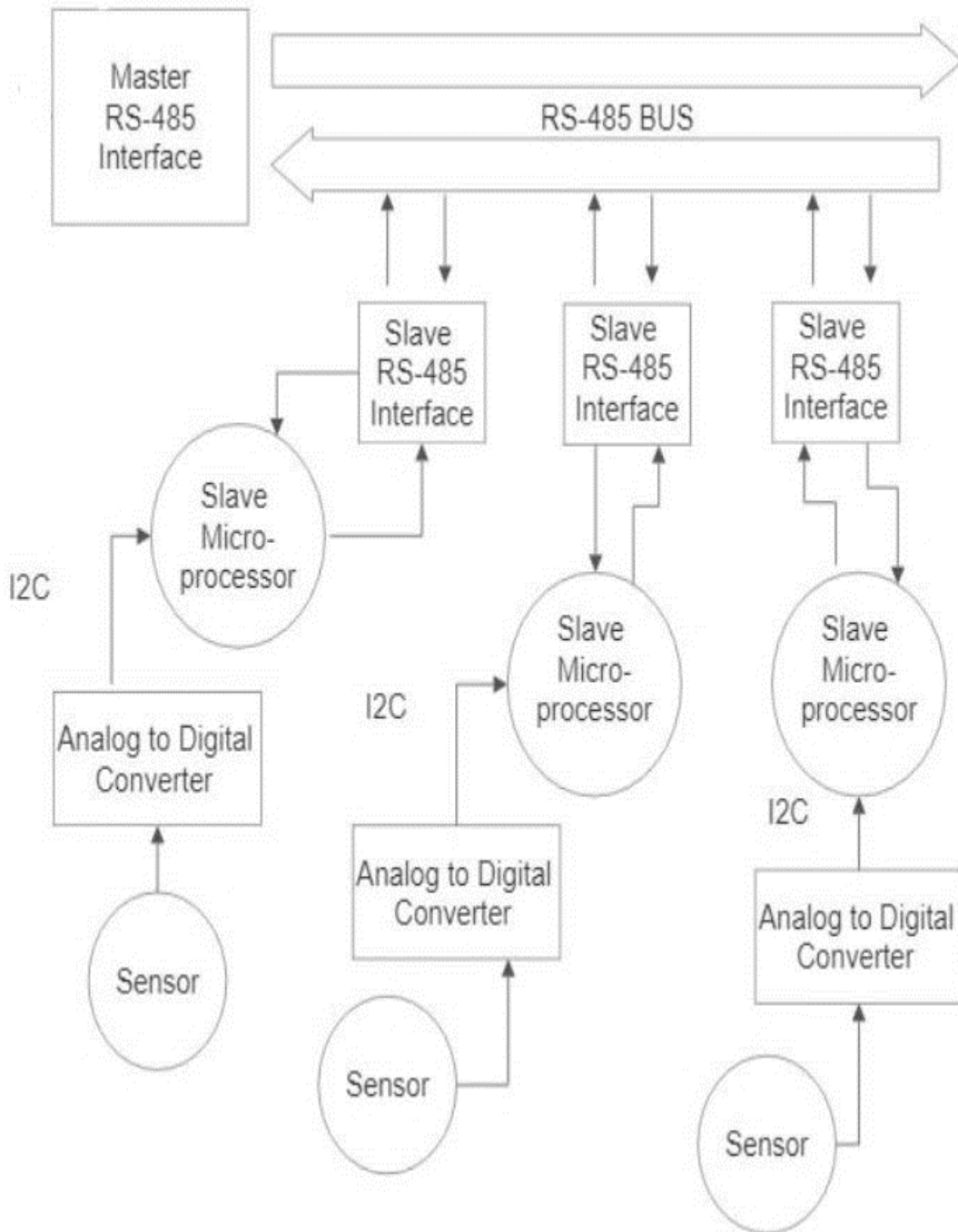

Figure 55 Second Subsystem (Sensors Board) Block Diagram

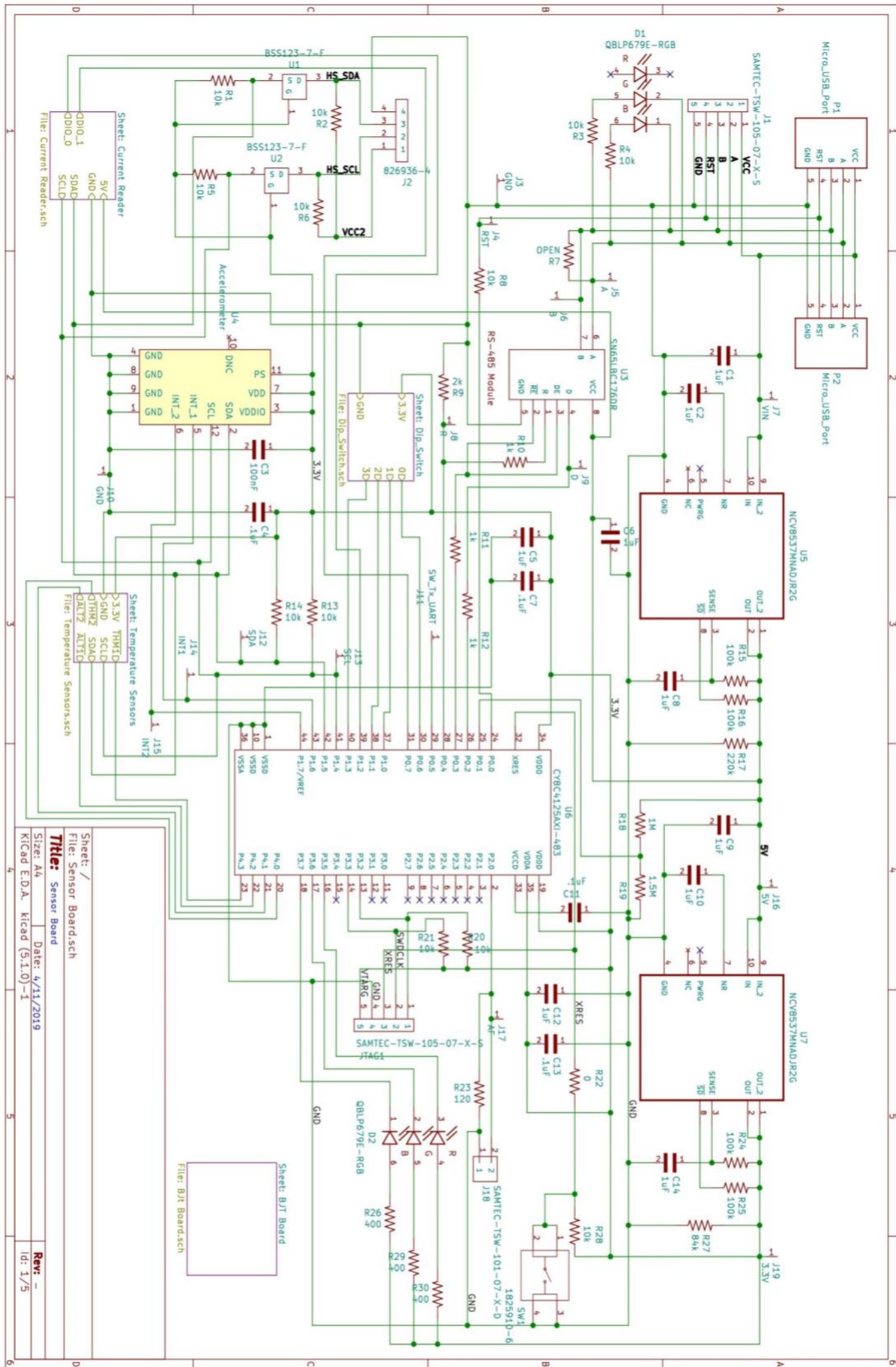

Figure 56 Second Subsystem (Sensor Board) Schematic Part 1

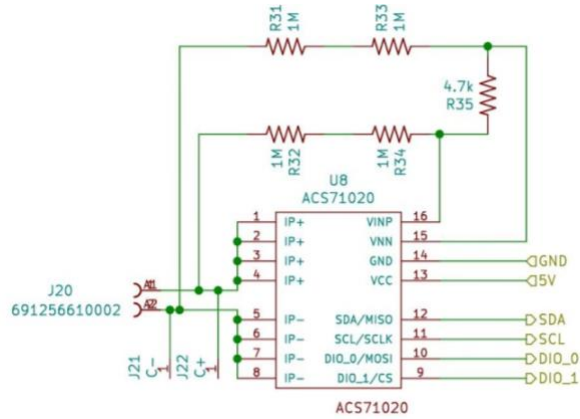

Figure 57 Second Subsystem (Sensor Board) Schematic Part

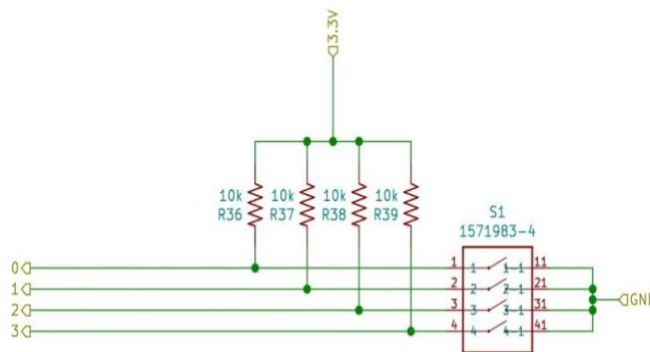

Figure 58 Second Subsystem (Sensor Board) Schematic Part 3

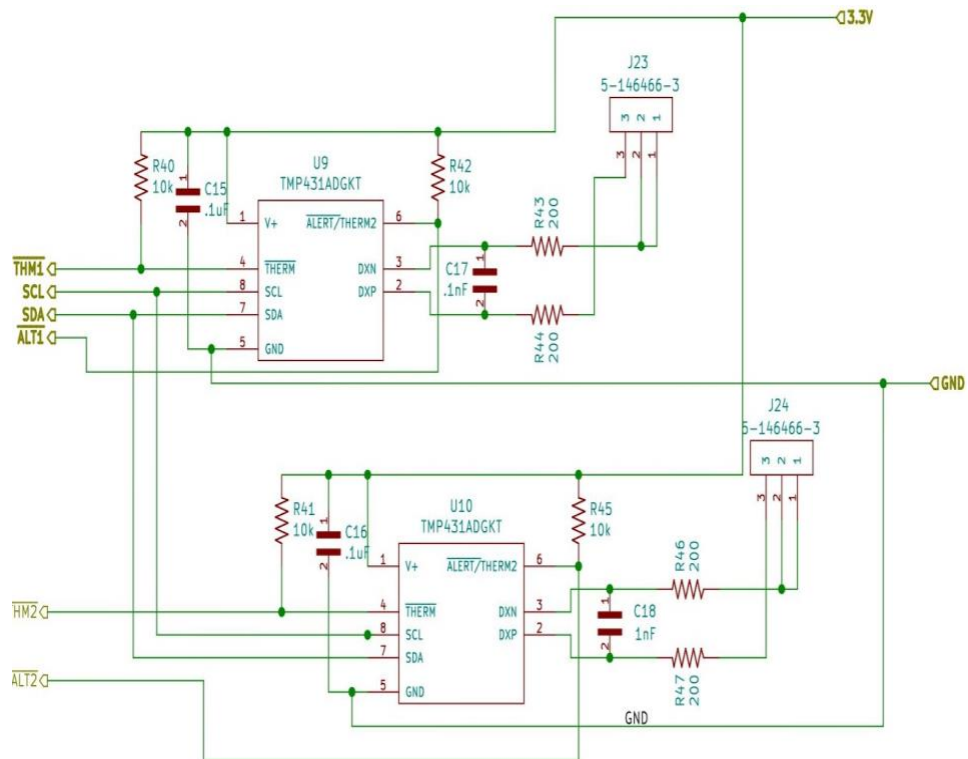

Figure 59 Second Subsystem (Sensor Board) Schematic Part 4

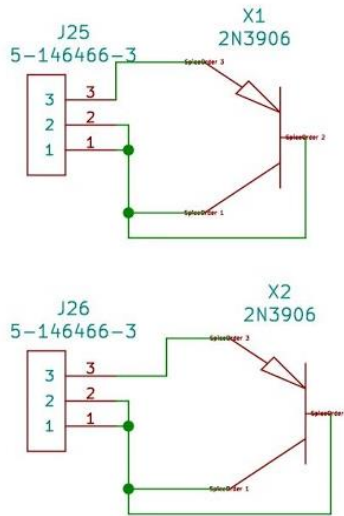

Figure 60 Second Subsystem (Sensor Board) Schematic Part 5

5.4 Third Subsystem, Breadboard Test, and Schematics

The third subsystem is the thermostat board. This board is used to gather the inputs from the thermostat and mimic them to the actual voltage lines to control the AC unit. The purpose of this is to be a buffer between the thermostat and the AC unit. We can then control the AC unit if the user wants to start or end operation or go into diagnostic mode.

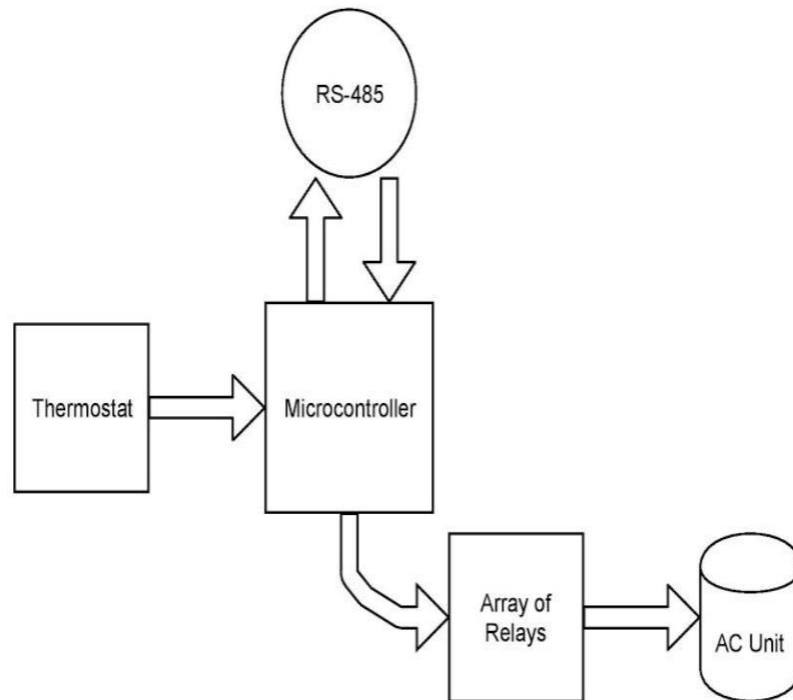

Figure 61 Third Subsystem (Thermostat Board) Block Diagram

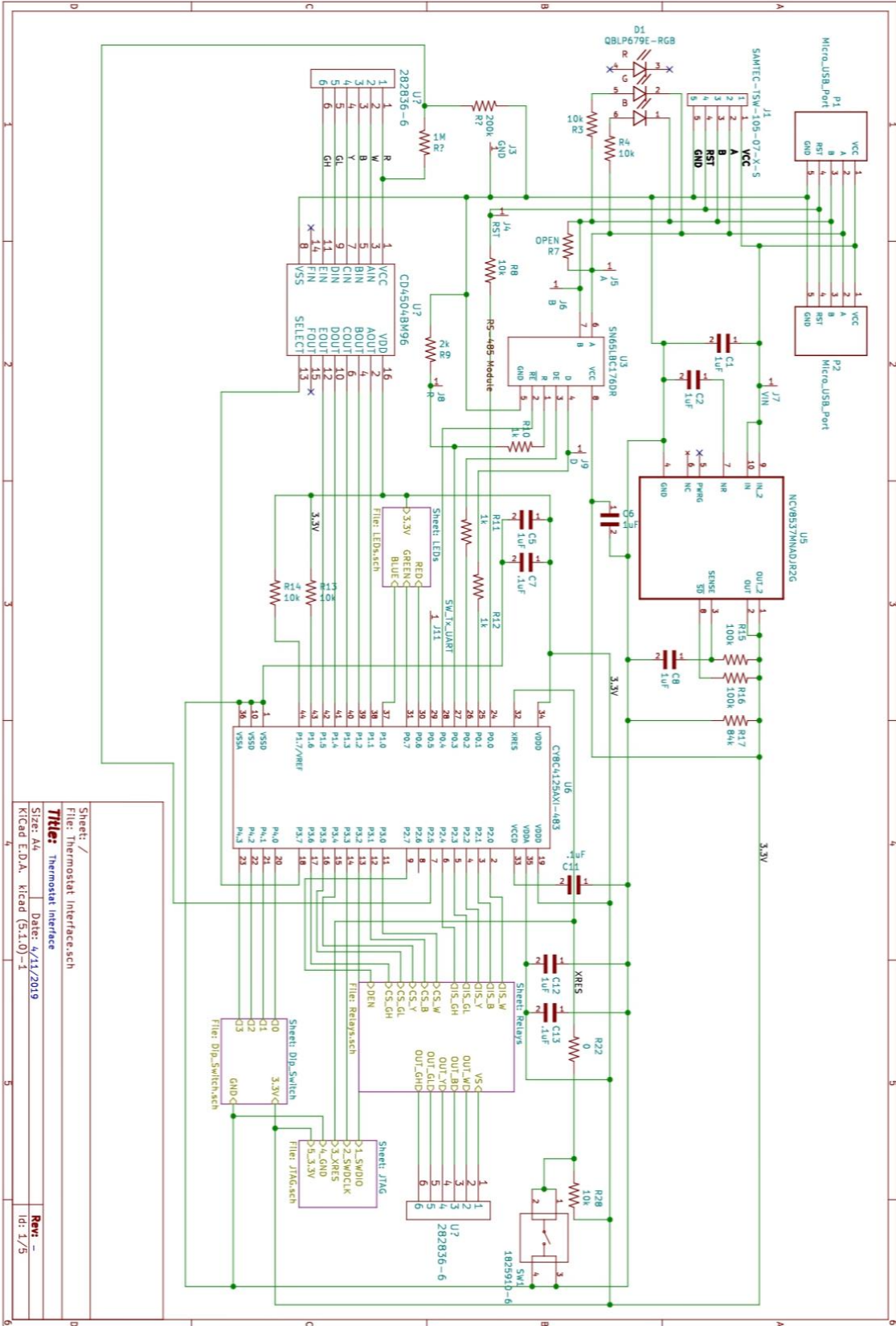

Figure 62 Third Subsystem (Thermostat Board) Schematic Part 1

Sheet: /
 File: Thermostat Interface.sch
Title: Thermostat Interface
 Size: A4 Date: 4/11/2019
 Kicad E.D.A. Kicad (5.1.0)-1
 Rev: -
 Id: 1/5

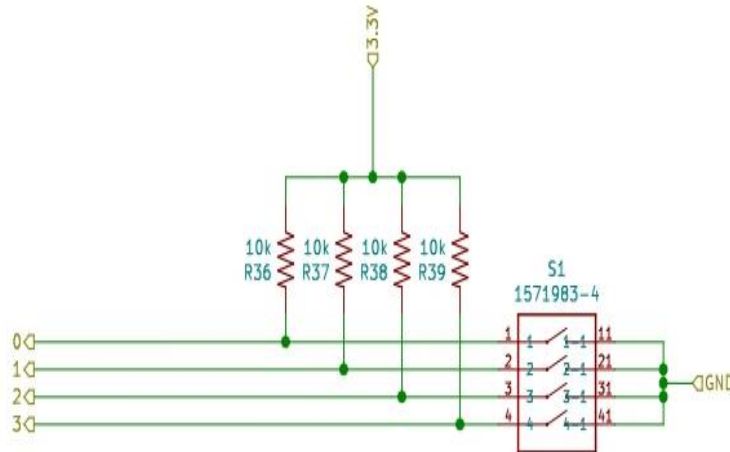

Figure 63 Third Subsystem (Thermostat Board) Schematic Part 2

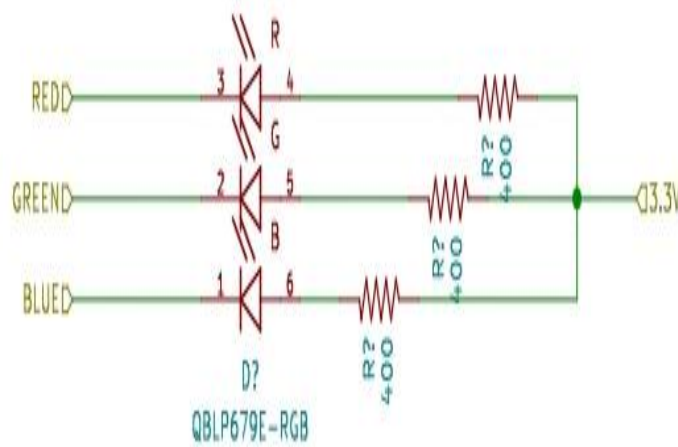

Figure 64 Third Subsystem (Thermostat Board) Schematic Part 3

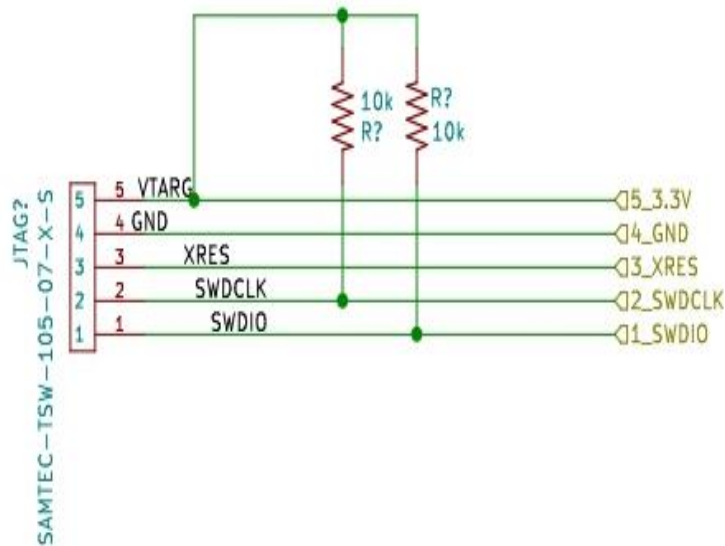

Figure 65 Third Subsystem (Thermostat Board) Schematic Part 4

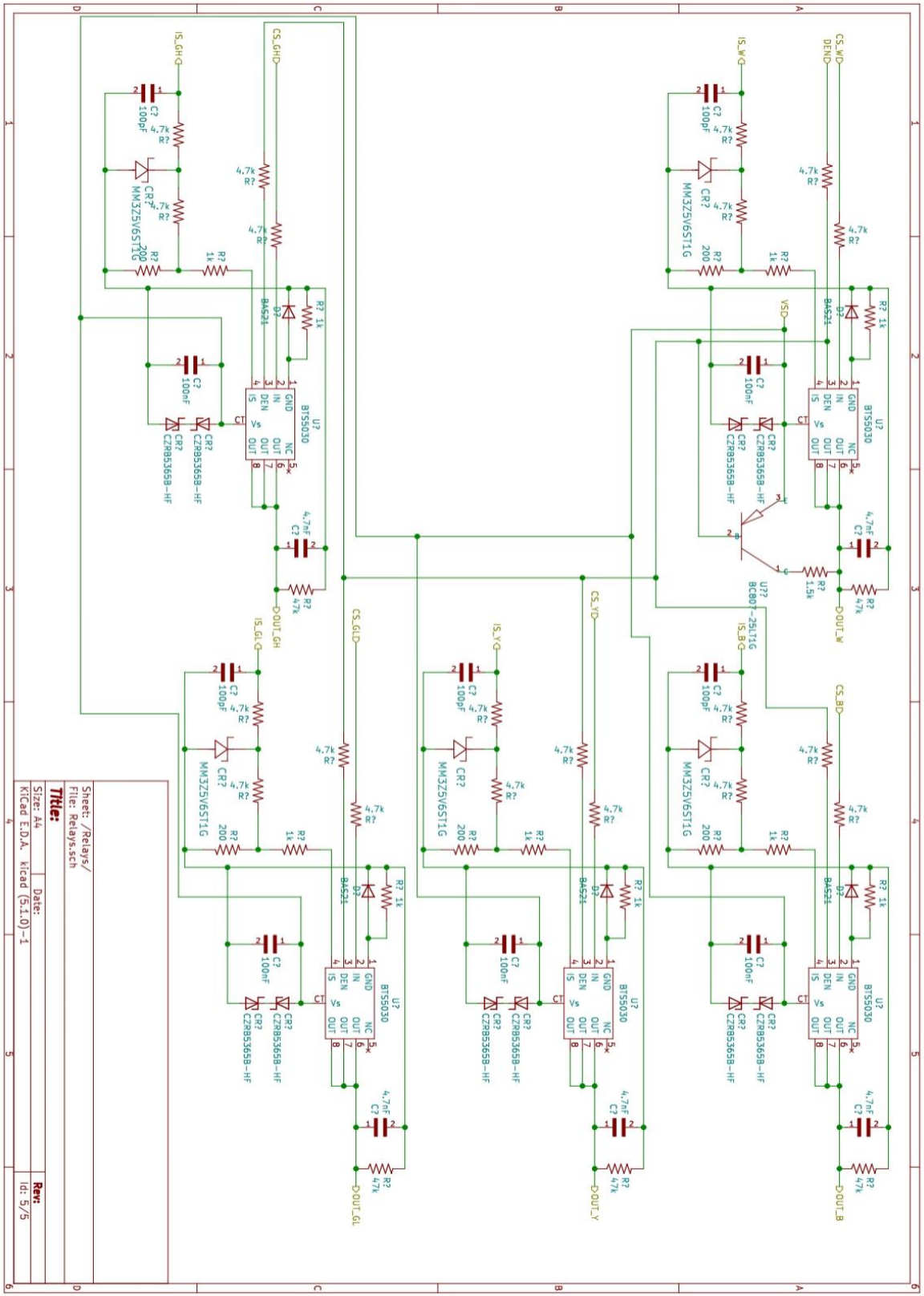

Figure 66 Third Subsystem (Thermostat Board) Schematic Part 5

Sheet: /Relays/ File: Relays.sch	Date:	Rev:
Title:		
Size: A4		
KiCad E.D.A. kicad (5.1.0)-1		Id: 5/5

5.5 Fourth Subsystem, Breadboard Test, and Schematics

The fourth subsystems are the microcontrollers. As we mentioned before, we are using three microcontrollers in our project, one CY8C6347BZI-BLD33 in the main board, and two CY8C4125AXI-483 in the sensor and thermostat board. Following are concise explanation of their operations:

5.5.1 The CY8C6347BZI-BLD33 Microcontroller (Main Board)

5.5.1.1 Main MCU Flow Chart

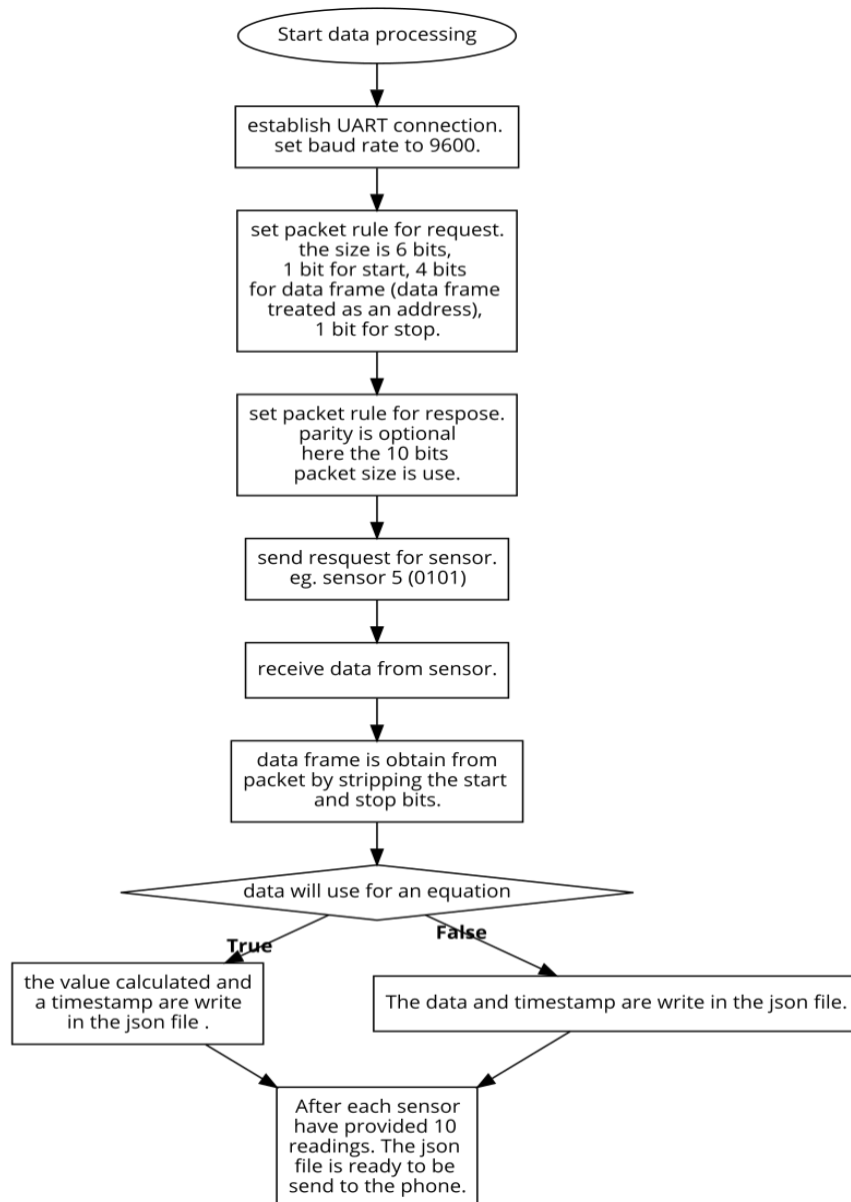

Figure 67 Main MCU Flow Chart Part 1

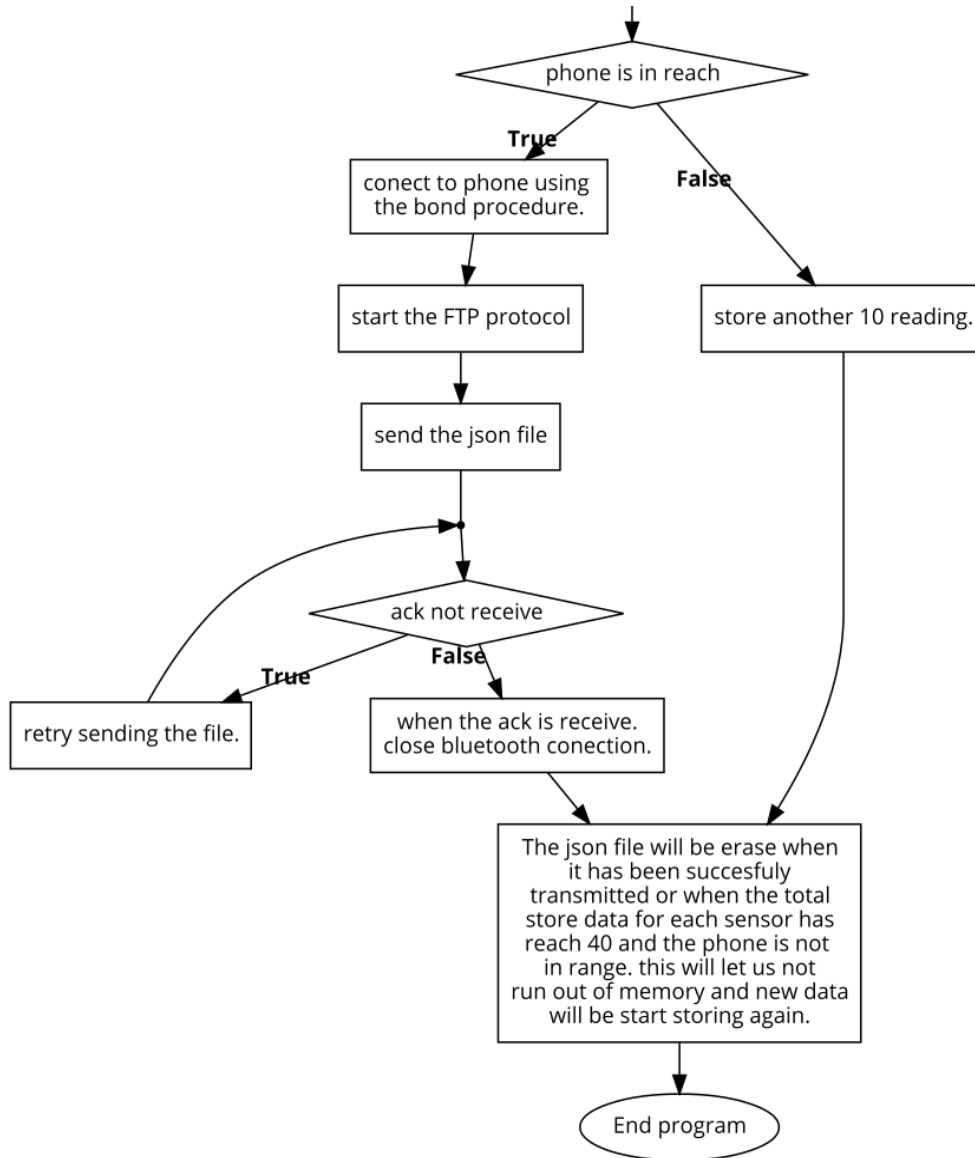

Figure 68 Main MCU Flow Chart Part 2

5.5.1.2 Boot sequence:

For the microcontroller we need to write our own boot sequence to be able to do a power on self-test of all the sensor and elements on our design. The best route is to boot from flash since the script will be located in there. How to specify the boot file location will depend on our PCB design and not on the microprocessor. E.g. on the STM32L4 Discovery kit the pin94 (BOOT 0) is connected to ground. For this design it means to boot from flash memory and from the system memory or the embedded SRAM. then we need to place our code in the boot memory by modify the linker code to target our code and place in the stack memory and to modify the startup code which is in the assembly file. We need to change/set values in the memory addresses 0 and 4 for the start of the stack and the program counter. Once this done our script should be call and perform the instructions to test our

equipment. The figure 1 shows the startup sequence we plan to use. Diagram it is showing one sensor for simplicity however the process is the repeats for each sensor. The boot up sequence will set and check all the thresholds and calibrations for the board.

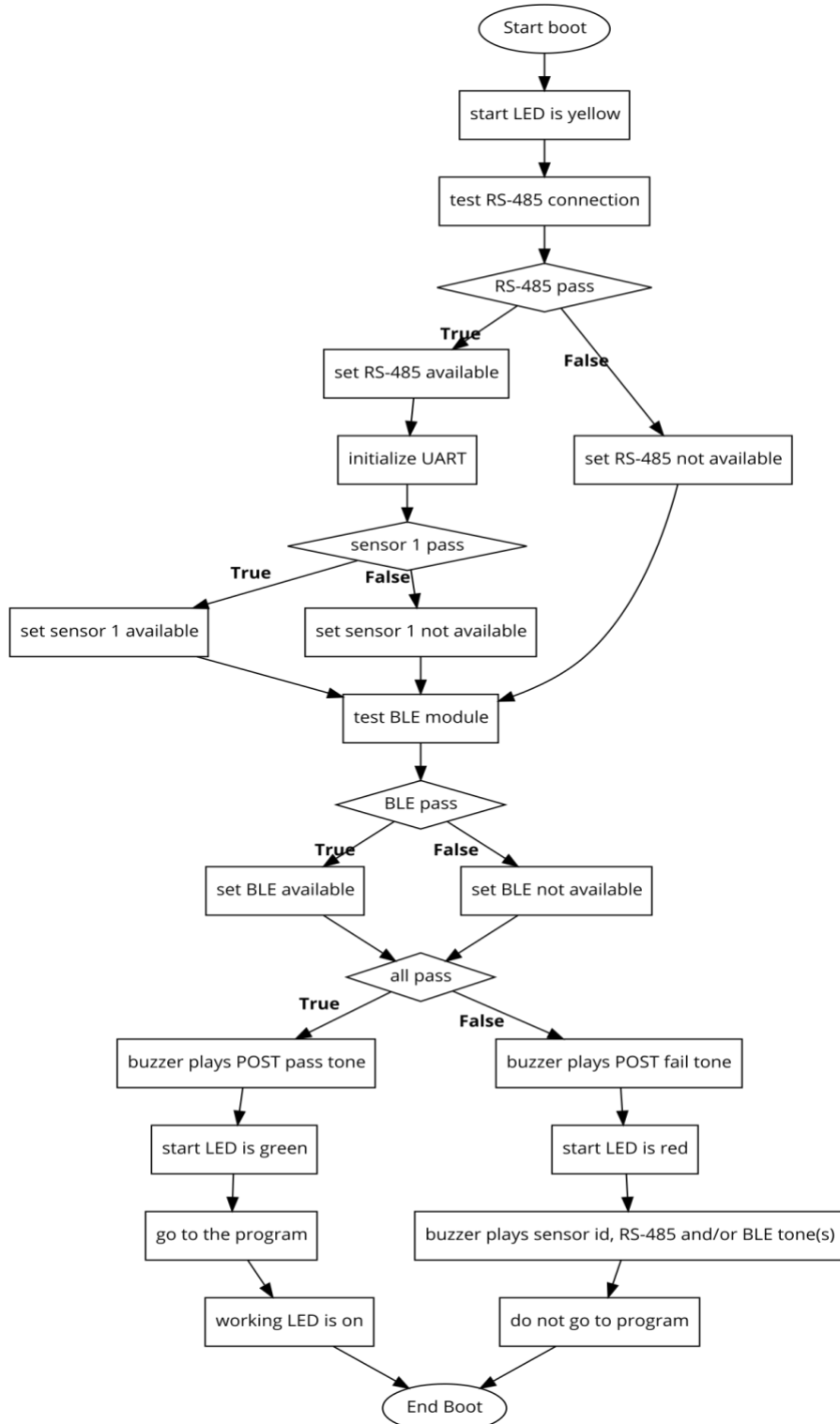

Figure 69 POST Sequence Flow Diagram

5.5.1.2.1 POST sequence explanation:

When the software starts the POST check the first thing is turn the LED designated as the power to turn yellow while boot sequence is working. For each element that is going to be test there is a flag value associate to it, pass = 1 and fail = 0. Testing the RS-485 module is done by testing the DE/RE pins signals. If the module does not respond it assume that is not working and the flag is set to fail, and the sensors check code is skip since the sensor are consider unreachable. Otherwise the module responds, and the flag is set to pass, and the code will continue to check the sensors. First the UART is initialized and each sensor is sending a code with their address. When sensor respond back the data packet content is not import, what is import for the booting is the fact it the sensor is reach and respond. The flag is set to pass if a response is received or fail if no response is received. Each sensor will be test sequentially. One area I am not sure how to test correctly is the sensor reading. The propose test I describe above is more checking the sensor board that the sensor.

Maybe when the microcontroller sends the packet to test the sensor board code could be put in the data frame that trigger the sensor board to test the sensor and, on the response, packet the data frame will be the response check of the sensor. if we receive the response and the data frame contains the bits that represent pass then it passes. In case a response is receive but the bits in the data frame represent fail then sensor flag equals fail. Next is to test the BLE module, I do not understand to make sure this works. My plan is to read the Bluetooth pins to see if it is turned on. If it then flag is set to pass otherwise is set to fail. Last part is to check all flags have pass as their value the start LED turns green, the buzzer plays the success tone, the working/processing led turns on and the post check ends then our program starts. If any of the flags have a fail as a value then the start led turns red, the buzzer plays the fail tone and the tone(s) for the element(s) that fail, post check ends then our program starts. In the case that the rs-485 or the Bluetooth are the elements that fail then our program would not run, and the device should turn off.

5.5.2 The CY8C4125AXI-483 Microcontroller (Thermostat Board)

The main processing will be contingent on the state that the AC unit is turned on or not. If the AC unit is on, then the microcontroller will be in sleep mode. The thermostat has around six major line wires that house the transformer power, fan and compressor lines, heat pumps, ground, and heat and air conditioning control lines. Here relays can be implemented to control the operation of the AC unit depending on the input from the user. With the inclusion of the thermostat, the diagnostic device will have control and knowledge of when and where the AC unit starts, on and off cycles, etc. The GPIO pins on the microcontroller can serve the purpose of communication control here for the power lines for turning on the AC unit.

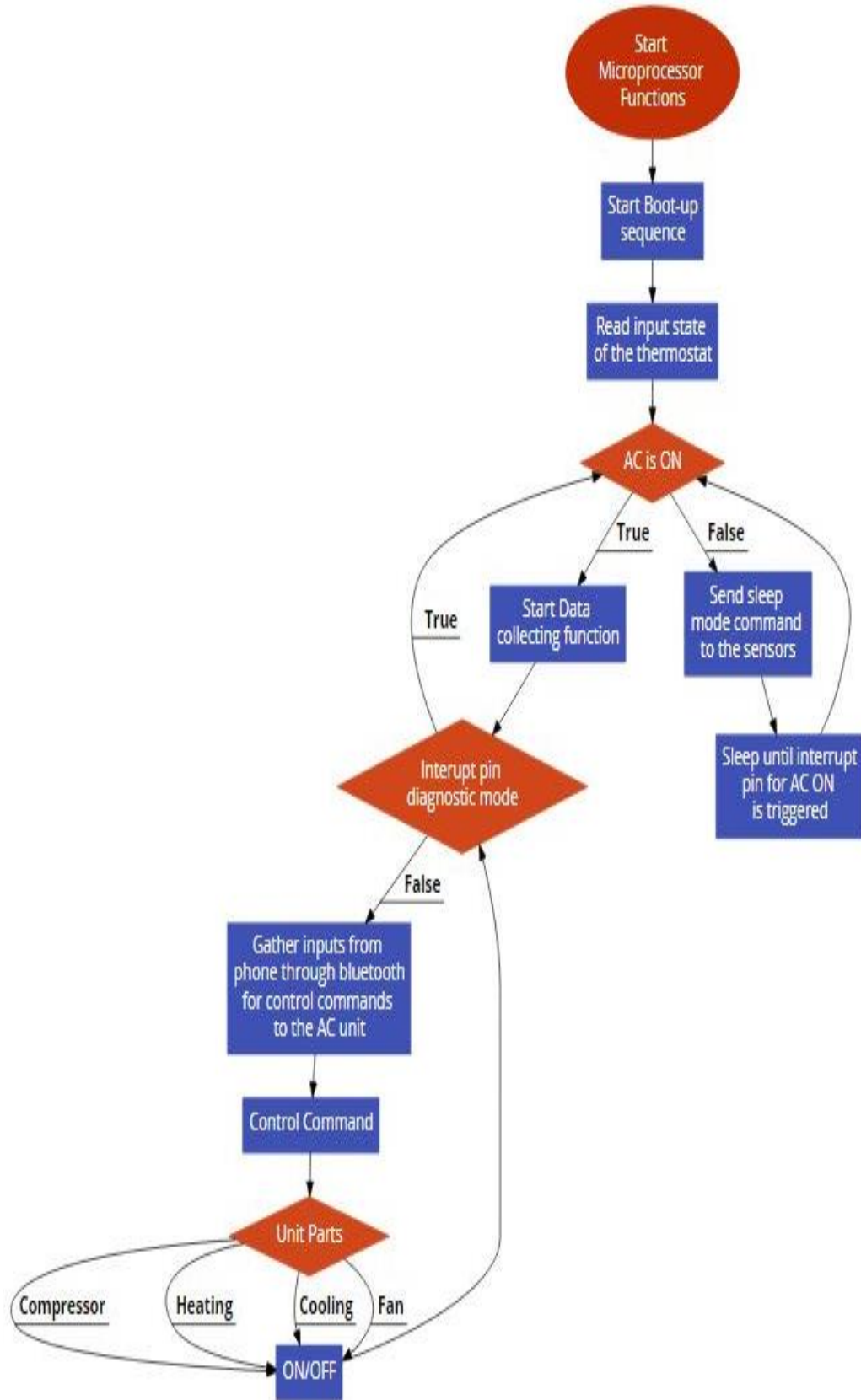

Figure 70 Thermostat Board Input Flow Chart

5.6 Software Design, Breadboard Test, and Schematics

The web application and the server (which includes the database), as expressed before, they are both responsible for the main storage and display of information. The following subsections are necessary for the complete understanding of the web application designing process:

5.7.1 Web Application User Stories and Their Expected Effort

Since we are using agile development, it is necessary to create the user stories. The following table presents the user stories, their needed efforts.

Table 16 User Stories

USER STORIES	PRIORITY	ACCOMPLISHMENT
As a user, I want to be able to input the BTU system specification, so that the correct airflow is calculated.	3	In the user sign up page, there is a section for them to enter the AC system's specifications including the BTU value of the system.
As a developer, I want the mobile app to send the user information to the server for storage and authentication purposes.	3	When the user creates a new account or logs in with an existent one, the mobile application sends either a post to or a get signal from the server correspondingly.
As a user, I want to be able to create a regular user account, so that I do not have to see administrative features on my application.	2	When the user logs in as an easy user, the home page does not show the data management option.
As a user, I want to be able to create a super user account, so that I have access to all the features including the administrative ones on my application.	2	When the user logs in as a super user, the home page shows the data management option.
As user, I want the web app to store my preferences/settings, so that I have all the calculations according to my AC system.	3	When the sets their AC system settings, the outputs are calculated using also that information.
As a user, I want to see a setting option in the main page, so that I can change my settings at any time I need to.	3	When the user goes to the home page, there is an option to go to the settings/preferences, in which they can change their configurations as needed.

Table 17 User Stories (Continue)

USER STORIES	PRIORITY	ACCOMPLISHMENT
As a developer, I want the web application to provide a warning every time a user tries to access pages that should only be accessed by AC technicians, so that accidental systems failures can be avoided.	5	When the user tries to access the system management page, a warning dialog box pops up letting the user know that any wrong action can affect the functionality of the system.
As a developer, I want the web application to receive data from the MCU through Bluetooth as needed, so data they can be used to accurately calculate and display the system health to the user.	1	The web application is connected via Bluetooth to the MCU, and it receives data from it as needed.
As a developer, I want the web application to connect to the AWS server, so that I can remotely store the user's login and settings information, and their AC system's health data.	1	When the user opens up the app, it connects to the server through internet.
As a developer, I want the web application to let the user know when the web application is not connected to the server, so that the user can check their internet connection.	1	When the use opens up the web application, if it cannot connect to the server, a message is printed on the welcome page indicating that to connection has been established.
As a user, I want the web application to have a help page available, so that I can refer to it anytime I need help with the application.	6	There is a help page available on the app, and when the user enters the it, information on the features and how to correctly use the app are displayed.
As a developer, a want the web application to provide access to the help page from all the other pages.	7	The help icon that sends the user to the help page is visible and accessible throughout the whole web application.

5.7.3 Application System Architecture

The application system architecture diagram is shown in the following picture, Figure 72:

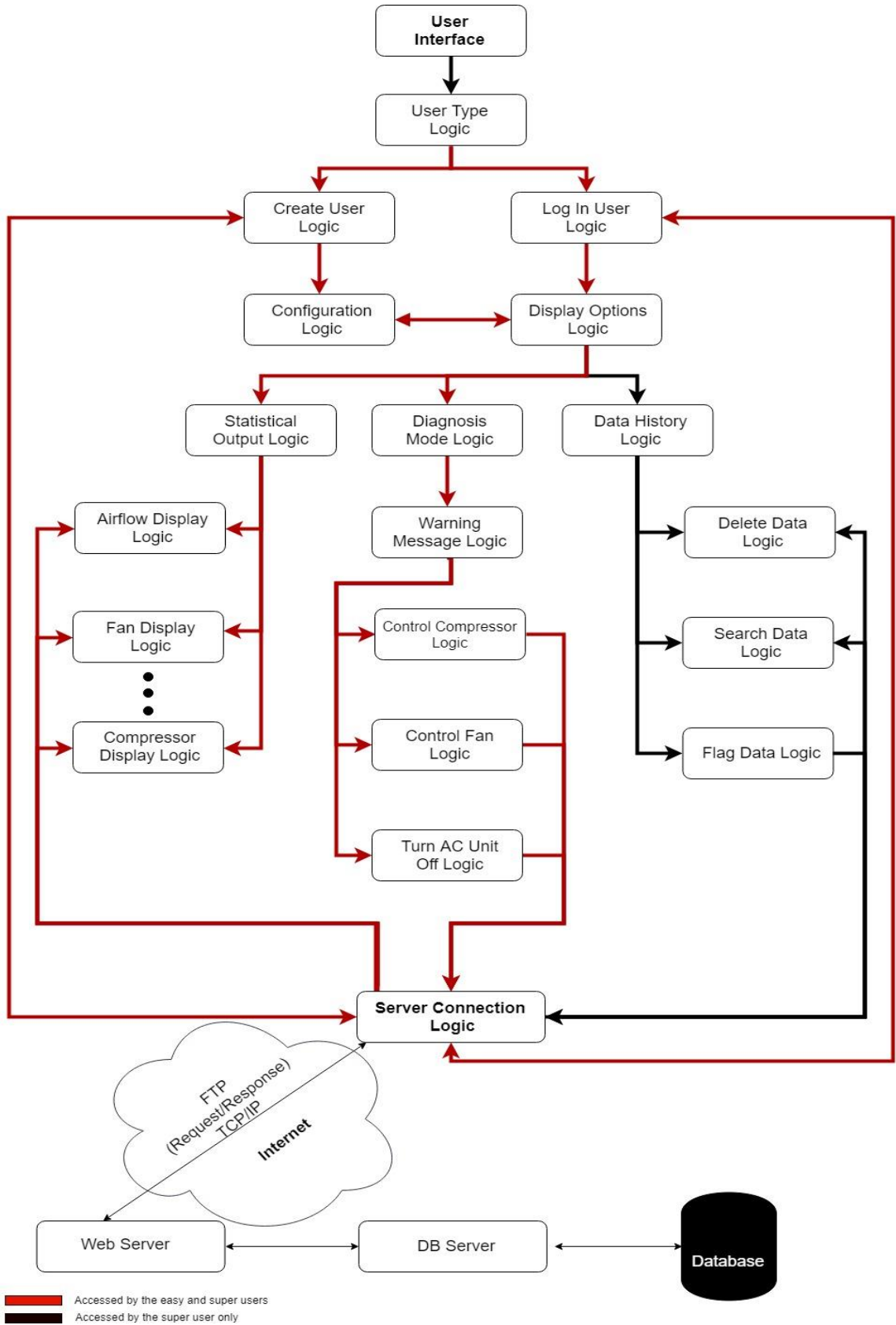

Figure 71 Application System Architecture

The application system architecture is processed as following:

- When the user presses the “Super User” button in the User Interface component, the User Type Logic sets the “user_type” string variable to “super” to further indicate that the created or logged in user should be given superuser privileges.
- When the user presses the “Easy User” button in the User Interface component, the User Type Logic sets the “user_type” string variable to “easy” to further indicate that the created or logged in user should be given easy user privileges.
- When the user presses the “Create New User” button in the User Interface component, the Log in User Logic prompts the user to enter their necessary information. It then checks if any of the information already exists by making the Server Connection Logic send a get call to the Web Server, which then contacts the DB Server that accesses the Database. If it exists, the corresponding error message (e.g. “This username is already in taken”) is printed to the UI. If not, the Creating User Logic checks starts creating a new user by making the Server Connection Logic send a post call to the Web Server, which then repeats the process mentioned above, and the new user information is added, including the type of user by reading the value store in the “user_type” variable, to the database. After, the Create User Logic moves to the configuration UI presented by the Configuration Logic, for the user to configure his/her account.
- When the user presses the “Login Existent User” button in the User Interface component, the Creating User Logic prompts the user to enter their corresponding login information. It then checks if this is a registered user by making the Server Connection Logic send a get call to the Web Server, which then contacts the DB Server that accesses the Database. If it exists, the Log in User Logic moves to the home UI provided by the Display Option Logic that shows its contents according to the values stored in te variable “user_type”. If it does not exist, then an error message (e.g. “Username or password does not match”) is printed to the UI.
- When the user presses the “Setting” button in the User Interface component (home), the Display Options Logic moves to the configuration UI presented by the Configuration Logic, for the user to configure or reconfigure his/her account.
- When the user presses the “System Statistics” button in the User Interface component (home), the Display Options Logic moves to the Statistical Output Logic that display to the UI different health classifications and summary of the parts of the system (e.g. The airflow). They are provided by the display logics associated with them (e.g. the Airflow Display Logic), first by making the Server Connection Logic send a get call to the Web Server, which then contacts the DB Server that accesses the Database, and then uses that data and the corresponding formulas for the necessary calculations.
- When the user presses the “Diagnoses” button in the User Interface component (home), the Display Options Logic moves to the Diagnose Mode

Logic that moves to the “Warning: Do not continue if you are not a qualified AC technician. Some changes may cause serious damages to your system” message that is displayed to the UI, provided by Warning Message Logic. If the user bypasses this message, the user will be able to remotely control different parts of the system. These feature are provided by the control logics by first making the Server Connection Logic send a get call to the Web Server, which contacts the DB Server that accesses the Database, and then uses that data and the corresponding formulas for the necessary calculations, or the Server Connection Logic sends a request for action signal to the MCU (this is not decided or defined yet).

- When a superuser (decided by reading the value stored in the “user_type” variable) presses the “Data History” button in the User Interface component (home), the Display Options Logic moves to the Data History Logic that provides the user with the features to manage the all the data present in the database. These feature are provided by the action logics (e.g. the Delete Data Logic), by first by making the Server Connection Logic send a get or post call to the Web Server, which then contacts the DB Server that accesses the Database, to either perform a lookup or change some data in it.
- Note that for some features, such as when a user wants to delete data from the database, the Server Connection Logic will first send a get call to check whether the data is present in the Database, and if it is, it then sends a post call to modify (delete data from) the database.

6. Project Prototype Construction and Coding

This section provides a detailed explanation of the design prototype we currently have, as well as the different resources, such as PCB vendors, that we plan to use to accomplish this project.

6.1 PCB Vendor and Assembly

For the PCB Vendors, we compared several websites using a standard 100x100mm, 2 layers, cheapest color, 1.6mm board thickness, 10 mil trace, 16 mil drill and a quantity base of 5 boards. The assembly will not be necessary for the manufacturer to include since the sponsor will have the capability to assemble their own boards. The price comparisons are listed below:

Table 18 PCB Vendors' Price Comparison Table

	Elecrow	JLPCB	PCBWay	Seed Studio
Total Price	\$4.90	\$2.00	\$5.22	\$4.90
Individual	\$0.98	\$0.40	\$1.04	\$0.98

The sponsor will have to decide what kind of service to use for the final PCB production and which vendor has better quality compared with price for the end product. The PCB outline for the sensor board has been outlined and the layout is shown below.

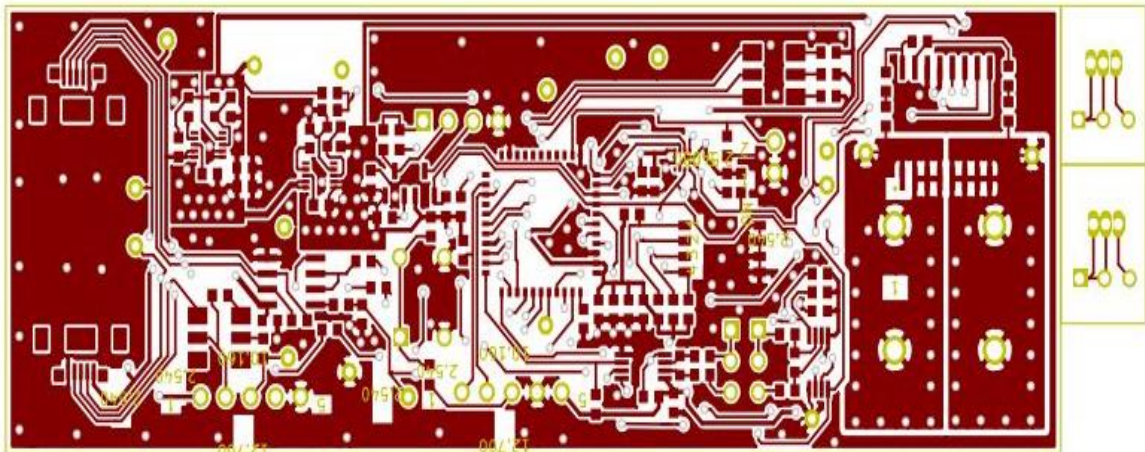

Figure 72 Main Board PCB

6.2 Final Coding Plan

The final code plan is provided below in the form of a class diagram and a picture showing the user interface windows we are planning to have in our application:

6.2.1 Web Application UML Diagram

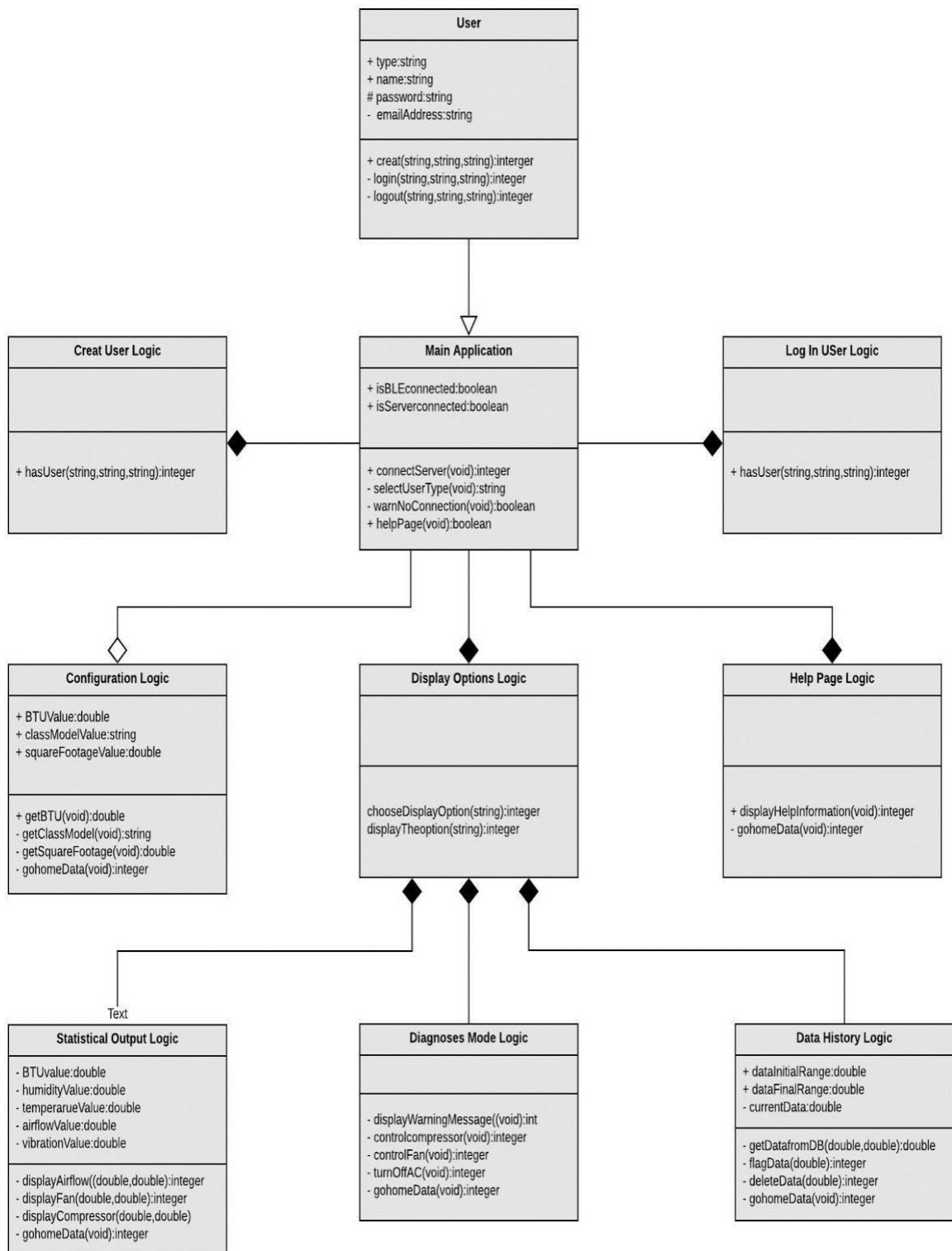

Figure 73 Application UML Class Diagram

6.2.2 Visual Diagram of User Interface

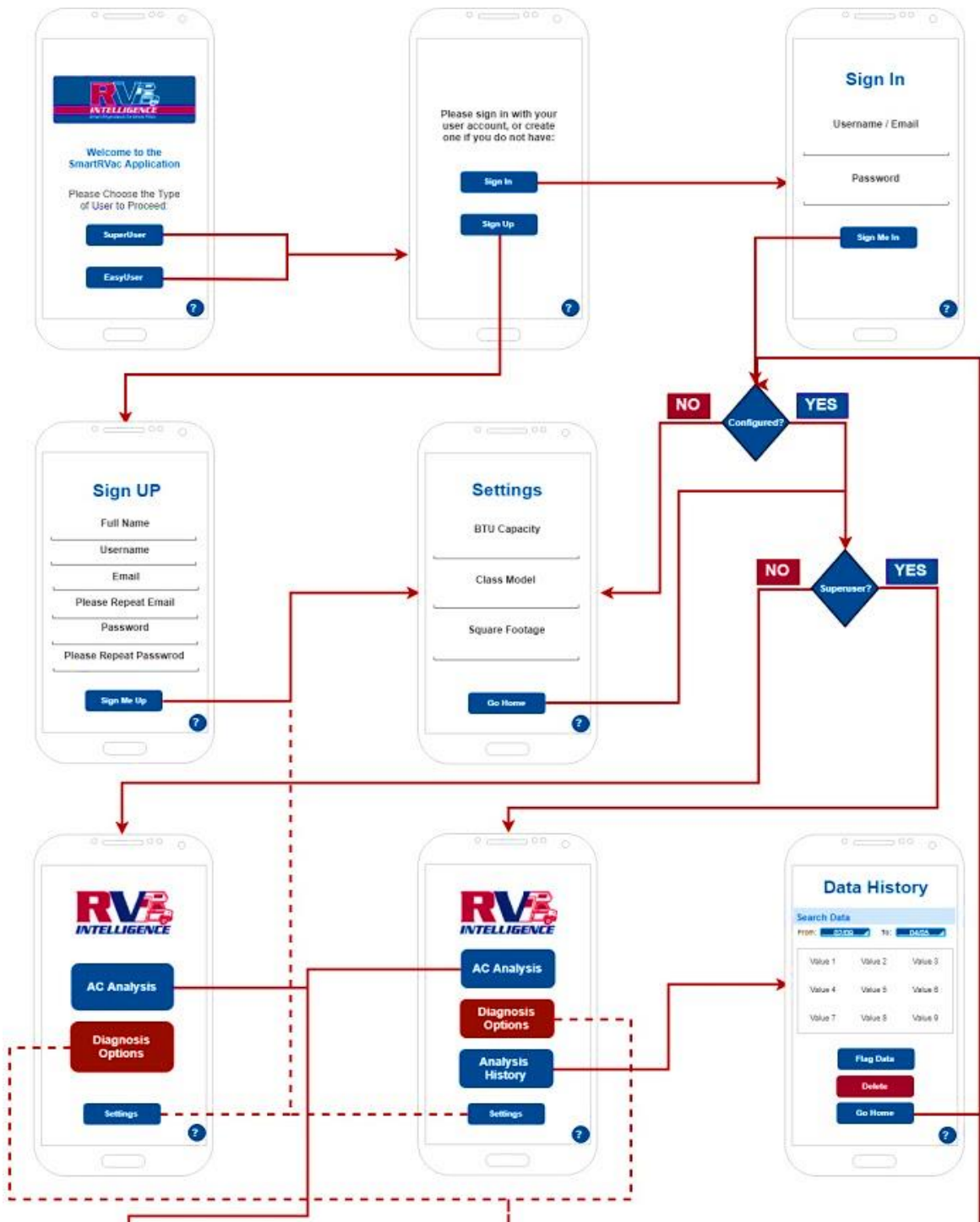

Figure 74 Visual Diagram of User Interface Part 1

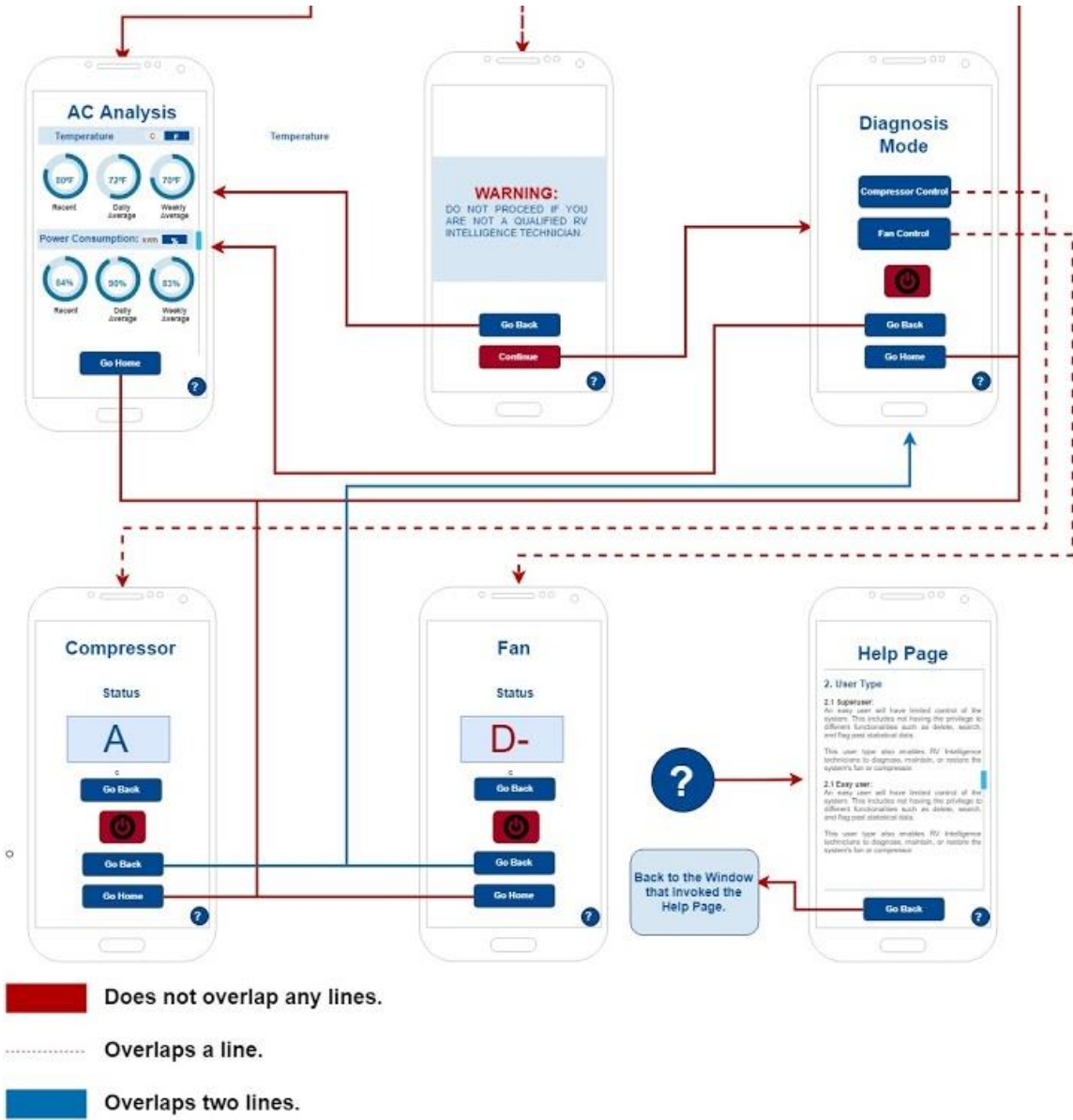

Figure 75 Visual Diagram of User Interface Part 2

7. Project Prototype Testing Plan

The prototype for the board will focus on the sensors and the communication parts since the rest is common place materials and parts, like the linear regulator for instance. The 12V interface needs to be able to convert a 12V signal into a 3.6V digital signal in order for the microprocessor to read it. Therefore, each input line on the chip will have a 12V signal that alternates to 0V and the output line will be read as well. The RS-485 will have two microcontrollers that will communicate with each other to and be able to probe the A and B points to verify differential signals. The current sensor will have a current running through the input pins with a digital multimeter connected in series to measure current. Precaution must be taken since the amperage will go above 1A and so parallel resistor will be used to disperse the current. The airflow sensor will be made later in senior design two that is specifically built to occupy as little space as possible in the cramped enclosure of the AC ducts. However, essentially a fan will produce the voltage and an ADC is used to convert it to the microcontroller. The other sensors require I2C communication and must be accessed through a microcontroller. The temperature sensors will be compared to other temperature readers like a thermocouple or a simple digital temperature reader.

7.1 System Test Environment and Specific Test

There were several breadboard testing procedures done and will further be tested on in the PCB board design later on in Senior Design II. The RS-485 SN65LBC176A Differential Bus Transceivers were tested first to serve as the backbone communication between all the boards spread throughout the system. Two Arduinos were used to serve as the master and slave function with the slave acting as the receiver and the master talking to the slave. The Master would firstly read an input from the serial window by the user and read the data bits to be transfer over to the slave. There were two ways to verify if the slave had received the data apart from the response from the slave for acknowledgement. The slaves serial window would print the data line again for the user to see and the second method was intentionally slowing the communication rate down to 1 second per bit.

The slave Arduino was connected to the RGB LED where a transfer of 1 would sink the green LED and a transfer of 0 would sink the blue LED. To verify whether the RS-485 module was communicating through the A and B lines, a yellow LED with a resistor was connected from anode to cathode from A to B and another red LED was placed in the opposite orientation. Whenever there is a 1, the voltage differential of A to B will light the yellow LED, while a 0 will light the red LED. Areas in the circuit were tested mostly for verification and troubleshooting. For instance, initially the A to B line would only transfer a 1 and not a 0. The issue was that mistakenly the reference line for the Arduino was not grounded with the breadboard's ground. Using the RGB LED in this testing also verified the functionality of the LED.

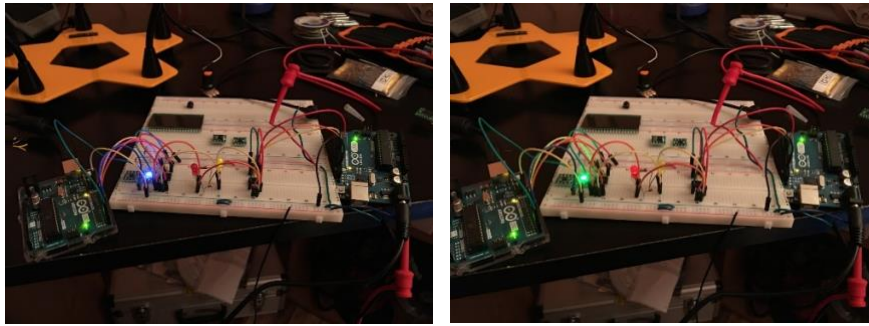

Figure 76 RGB LED Test Part

The next testing was the CD4504B Hex Voltage Level Shifter used for the 12V interface between the thermostat and the AC control lines. The input to the 12V line was fed through a power supply with a switch used for the digital 12V signal. On one side of the switch is a pull up resistor to 12V and when pressed connects to the ground. Therefore, when the switch is pressed a low signal is sent through the input line of the chip and a high is sent when not pressed. The output line should be what the input is only read at 3.6V for the microcontroller to read.

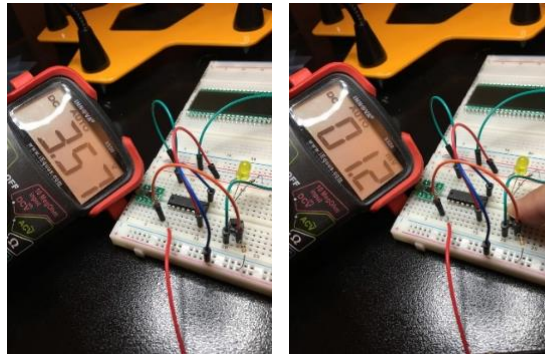

Figure 77 Hex Voltage Level Shifter Test

The detection point was another test that was focused on and a test point we were interested in. The switch was taken out from the breadboard and replaced with a voltage divider with the lower resistor becoming a potentiometer. The potentiometer was then lowered enough to verify with the datasheet where the voltage would trigger for the chip to register a low from the input pin.

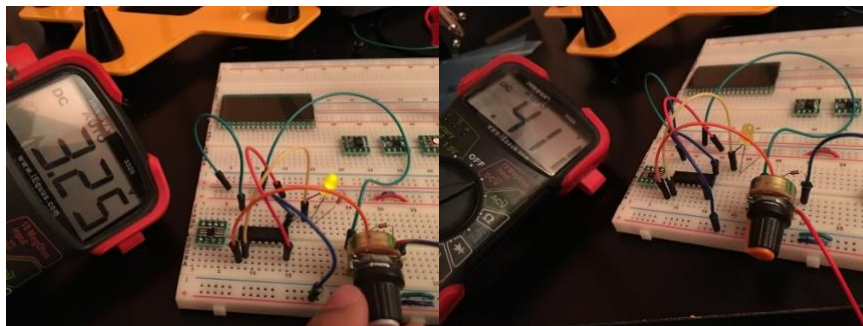

Figure 78 Potentiometer Testing

For the rest of the testing, I2C was used to communicate with the boards. Arduino was used to communicate with all the devices with the exception of the flash memory and the current sensor. The temperature sensor's external diode was used in a bath of cold water. Two other temperature readers were used to verify the actual temperature and see the error rate of the temperature reads. The Arduino printed the current measurements from the ACS720 and the DMM verified the current readings. The voltage out from the chip was then connected to the ADC of the Arduino. Below are all the sensor components capable with breadboard tied together through the I2C pins and ADC to the Arduino without the testing procedures above for breadboard part description. On the bottom right is the ACS720 current sensor, bottom and top left are the TMP431 temperature sensors with digital inputs coming into the Arduino pins 0 and 1, and the top right is the temperature/humidity sensor.

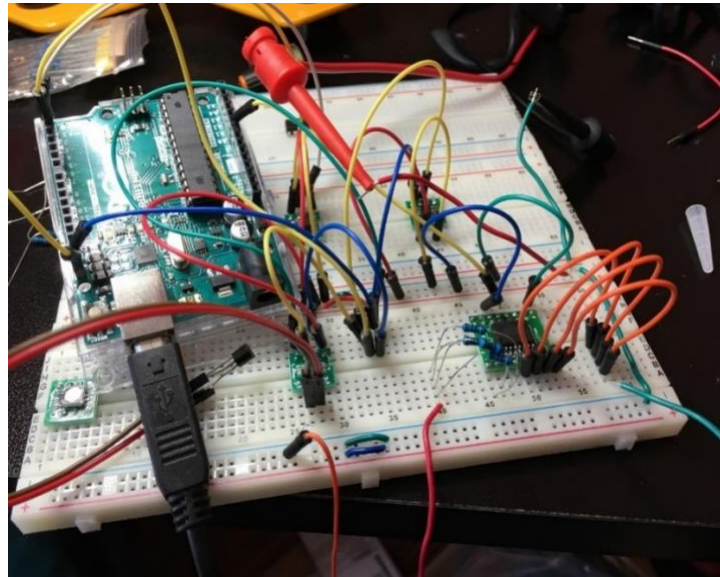

Figure 79 All Components Test

7.2 User's Manual

The SmartRVac is a monitoring device for Air Conditioner (A/C) unit in Recreational Vehicles (RV). the user needs to follow all safety procedure stated on their A/C unit manual and in the RV manual. Note that we are not to be held responsible for any damages and/or injuries that can be arise from improper installation, negligent usage, or a combination of the ones stated.

7.2.1 Product Operation

This user manual is designed to help the user install and use the device and companion application. It is recommended that the user contact a technician for proper installation. Below there are the necessary information for safety, installation, usage, and troubleshooting.

7.2.2 Safety Precautions

Follow the safety precautions below to prevent injuries to you and damage to the device.

1. Remembered to turn off the vehicle, A/C unit and any other device related when dealing with the power lines, thermostat lines, and installing the sensors.
2. Make sure to ground yourself, avoid wearing jewelry and avoid touching exposed cables without testing if they are live.
3. Check that all cables are properly connected, and no cable is exposed before powering the unit.
4. Although the device is in enclosure keep away from water and any other liquids to prevent damage to the device and other associated system.

7.2.3 Installing and Using the SmartRVac

To properly install the system, please take the following steps:

1. Download the web application on your preferred device.
2. Refer to the Website Manual and register the SmartRVac.
3. Place the device close to the RV AC unit.
4. Connect the secondary boards to the main device using the provided USB cables according to the port labels.
5. Connect the device to the AC unit and the thermostat according to the ports' labels.
6. Plug the device to the power supply, 6V to 12V and 50 Hz to 60Hz.
7. Wait for about 40 seconds until the power LED is turned on in red.
8. Press the turn on button.
9. Wait for about 20 seconds until the power LED is turned on in green.
10. Wait for about 20 seconds until the sensors LEDs are turned on in red.
11. Pair your cell phone, tablet, or computer with SmartRVac.
12. Connect the phone, tablet, or computer you are using to the internet.
13. The device is then properly installed and ready for use.

To properly use the system, please take the following steps:

1. Ensure the installation steps were taken and the system is ready for use.
2. Press help icon and read the information on help page before using the system.
3. Sign in or log in into the application.
4. In the configuration page, please enter your AC unit's BTU value, class model, and RV's square footage. You can find that information in the AC and RV user's manuals.
5. Enjoy your system.
6. Please do not ignore any displayed warnings.

7.2.4 Troubleshooting Tips

Table 19 Troubleshooting Tips

<p>Device's power LEDs are not on or green.</p>	<ul style="list-style-type: none"> • Check the wiring for the 12V battery plug in. The input signals can be placed in reverse. • Make sure the battery of the RV is in good and functional health.
<p>No sensors detected</p>	<ul style="list-style-type: none"> • Make sure the micro USB cables are positioned in an adequate way as to not have a bad connection and that the terminals are in good order. • Verify if the communication LEDs are blinking green and blue.
<p>Phone not connecting through Bluetooth</p>	<ul style="list-style-type: none"> • Make sure that your phone's Bluetooth is on and functional • Verify if the Bluetooth LED is green. • Press the reset button on the controller.
<p>System won't respond to the Thermostat signals</p>	<ul style="list-style-type: none"> • Recheck the voltage lines are the correct color and name for both sides. • Check if the thermostat controllers can in fact control the AC unit.
<p>Phone application won't start</p>	<ul style="list-style-type: none"> • Restart the application and load the application again. • Make sure the phone is connected to the internet. • Refer to the help page online.

8. Administrative Content

This system presents all the of administrative contents of the group as well as the project. We show the work distribution for senior design I, our milestone for the project, and an analysis of the budget. During senior design I, we acquire most of the parts and did research for the project. In senior design II all the remaining parts will be acquire and a functional product will be presented.

8.1 Work Distribution

The table below show the distribution of work between the group. The research was completed by al members as well as the recording of the finding.

Table 20 Group Members Work Distributions

Group Member	Primary Work	Secondary Work
Francisco Martinez	Sensors and PCB Boards	MCU
Claudio Leandro de S. Afonso	Web App and Server	MCU
Sergio E. Perez-Aponte	MCU	Web App and Server

8.2 Milestone Discussion

In this section the milestone is break down in two parts, senior design I in spring of 2019 and the second part, senior design II in fall 2019. We will show our plan for both sections below.

8.2.1 Senior Design 1

Table 21 Senior Design 1 Milestone

Description	Duration	Dates
Group Formation	3 Day	1/8/19 - 1/11/19
Project Decision	2 Weeks	1/11/19 - 1/25/19
Divide and Conquer V1	4 Days	1/29/19 - 2/1/19
Researching	1 Week	2/1/19 - 2/7/19
Selecting Parts	3 Days	2/7/19 - 2/10/19
Designing Initial Prototype	2 Weeks	2/10/19- 2/24/19

Divide and Conquer V2	3 Days	2/11/19 - 2/14/19
Testing Initial Prototype	1 Week	2/24/19- 3/3/19
Approval	1 Day	3/4/19
60-pages draft	3 weeks	3/1/19 - 3/25/19
100-page draft	2 weeks	3/26/19 - 4/8/19
Final document	2 weeks	4/9/19 - 4/22/19

The above table is a tentative schedule for the duration of the Senior Design 1 class. It is intended to keep the team on track and ensure the progress towards the effective completion of the first part of the project. Following this plan will point the team to the right direction when starting Senior Design 2 class.

8.2.2 Senior Design 2

Table 22 Senior Design 2 Milestone

<u>Description</u>	<u>Duration</u>	<u>Dates</u>
Designing Final Prototype	3 Weeks	8/26/19 - 9/15/19
Testing Final Prototype	1 Week	9/16/19 - 9/22/19
Approval	1 Day	9/23/19
Develop Embedded code	6 weeks	9/1/19 - 10/13/19
Develop Mobile Application	6 weeks	9/1/19 - 10/13/19
Develop Server API and Database	4 weeks	9/8/19 - 10/6/19
Testing Software	3 Days	10/14/19 - 10/16/19
Testing Hardware	3 Days	10/14/19 - 10/16/19
Interfacing with Sensors	1 Week	10/17/19 - 10/23/19
Assembling Parts	2 Weeks	10/24/19 - 11/5/19
RV AC Test Procedures	1 Week	11/6/19 - 11/12/19
Presentation	1 Week	TBD

The above table is a tentative schedule for the duration of the Senior Design 2 class. It is intended to keep the team on track and ensure the progress towards the effective completion of the second part of the project. However, this schedule should be more realistic at the end of Senior Design 1. As the table demonstrates, the project must be built and fully functional and the end of the Senior Design 2 class.

8.3 Budget and Finance Discussion

The SmartRVac project is been fully sponsor by Herb Gingold, founder of RV Intelligence. During research and discussion with Mr. Gingold we have found that for recreational vehicles there is not a product like this one available. The closes products are for business and residentials A/C unit. Our goal is to design a product that is affordable and valuable to the end user. The A/C unit we plan to use for testing the device is not included in budget since the sponsor is currently in talks with a partner to get one donated. The estimated price for the unit is about \$300.00. The table below shows a projected cost of the project.

Table 23 Project Budget and Finance

Item	Vendor	Price	Amount	Estimated Price
PSoC 4 BLE Module	Digikey	\$13.97	1	\$13.97
PsoC 4	Digikey	\$3.97	2	\$7.94
Current Sensor	Digikey	\$0.59	1	\$0.59
Temperature Sensor	Digikey	\$0.26	1	\$0.26
Vibration Sensor	Digikey	\$3.96	1	\$3.96
Enclosure		TBD	1	\$10
Linear Regulator	Digikey	\$0.38	1	\$0.38
PCB	PCBway	\$1.74	3	\$5.22
RS-485 Module	Digikey	\$2.77	4	\$11.08
Misc.		\$60.00	1	\$60.00
CYBLE-222005-EVAL	Mouser	\$18.75	1	\$18.75
CY8CKIT-042 PSoC 4 Pioneer Kit	Mouser	\$28.13	1	\$28.13
			Total	\$160.28

Table 23 above reflect the budget as a right now in the design of the product. We have included all the parts that have been acquire and all other we will get in the near future. Keep the budget low is very important for our project since the development of this project is indented to take this product to the market. Our sponsor works closely

with us to make sure we are selecting parts that align with his business need and will help keep the price of manufacturing the device in a price range that is competitive on the market.

Appendix A – Copyright Permissions

Sensaphone Photo Usage

DB Dave Breisacher <dbreisac@sensaphone.com>
Thu 4/18, 4:13 PM
Claudio Leandro Afonso

Flag for follow up.

Hi Claudio,

You're more than welcome to use any photos of Sensaphone products for your project report. Thanks for checking! Please feel free to use any photos that are on the website.

Thanks,
Dave

Dave Breisacher | Marketing Director
dbreisacher@sensaphone.com
610-675-2227
www.sensaphone.com
901 Tryens Road, Aston, PA 19014

Thank you so much for your feedback.

Thank you so much for your response.

Thank you for the photos.

Report inappropriate text

Contact Sensaphone Sales Team

SW Spike Wilson <swilson@sensaphone.com>
Thu 4/18, 4:13 PM
Claudio Leandro Afonso; Dave Breisacher <dbreisacher@sensaphone.com>

Flag for follow up.

Hello Claudio!

You are welcome to use our imagery. I attached our Director of Marketing to this email so you can coordinate this conversation with him.

If you don't mind - seeing we will be closed tomorrow, and this is a holiday weekend, please be patient if an email correspondence take a little time for a response.

I hope you have an incredible weekend, and a better holiday!

Warmest Regards,
Spike Wilson
Product Specialist and Vendor Support
swilson@sensaphone.com / 610-675-2216
www.sensaphone.com 901 Tryens Road, Aston PA 19014
Hours: 8:30am - 5:00pm EST

General Inquiry [#1817]

LW Laura Wingren <lwingren@qhnamerica.com>
Thu 4/18, 5:30 PM
Claudio Leandro Afonso; Internet Account <internet@qhnamerica.com>

Flag for follow up.

Hello,
You have our permission to cite our website and use the pics/prods for your report as cited. Thank you for checking with us and best of luck! :)

Laura Wingren
Marketing Manager

George Brazil
A/C Conditioning & Heating
Cell: (480) 263-0961
George@smi-hvac.com

Getting too much email from Laura Wingren <lwingren@qhnamerica.com>? You can unsubscribe

On Thu, Apr 18, 2019 at 3:52 PM George Brazil - General Inquiry <no-reply@georgebrazilhvac.com> wrote:
A new general inquiry has been received.

Name	Claudio Afonso
Email	claudio-leandro3@uic.edu
Phone	4079241443
Question or comment:	
Hello,	
My name is Claudio Afonso, and I am a senior majoring in Computer Engineering at the University of Central Florida. My group and I are working on a senior design project, and we would like to cite your website and use pictures of your products in our project report.	
I was wondering whether it is fine with you.	
Thank You Claudio Afonso Computer Engineering 2019 University of Central Florida claudio-leandro3@uic.edu +1-407-924-1443	

Citation Permission Reference Id: 20190418-639617362825

 Applications Engineering <Applications.Engineering@digikkey.com>
Fri 4/19, 12:13 AM
Claudio Leandro Afonso

Flag for follow up.

Hello,

Thank you for your inquiry. Yes, the information on our website is free to use.

Check out Digii-Key's TechForum for assistance anytime!
Were you satisfied with our service? Please take our short [survey](#) to help us improve.

Andy Roskeas
Applications Engineering Technician
Digii-Key Electronics
701 Stock Ave S
Fond Du Lac, WI, 54701 USA
Phone +1 202 324 4939
www.digiikey.com

 **Applications Engineering**

[Applications Engineering Terms of Service](#)

Getting too much email from Applications Engineering <Applications.Engineering@digikkey.com>? You can [unsubscribe](#)

[Report inappropriate text](#)

-----Original Message-----

From: Claudio Leandro Afonso [<mailto:claudio-leandro3@knights.ucf.edu>]
Sent: Thursday, April 18, 2019 9:44:45 PM
To: Applications Engineering
Subject: Citation Permission Reference Id: 20190418-639617362825

Hello,

My name is Claudio Afonso, and I am a senior majoring in Computer Engineering at the University of Central Florida. My group and I are working on a senior design project, and we would like to cite and use pictures from your website in our project report.

I was wondering whether it is fine with you.

Thank you,

Claudio Afonso
Computer Engineering 2019
University of Central Florida
claudio-leandro3@knights.ucf.edu
+1-407-924-1443

From: "PartProcurer.com" <bdeluca@optonline.net> on behalf of "PartProcurer.com" <bdeluca@optonline.net>

Reply-To: "claudio-leandro3@knights.ucf.edu" <claudio-leandro3@knights.ucf.edu>

Date: Thursday, April 18, 2019 at 11:03 PM

To: <bdeluca@optonline.net>

Subject: New message from Claudio Afonso

My name is Claudio Afonso, and I am a senior majoring in Computer Engineering at the University of Central Florida. My group and I are working on a senior design project, and we would like to cite and use pictures from your website in our project report.

I was wondering whether it is fine with you.

-Claudio Afonso (claudio-leandro3@knights.ucf.edu)

From: Claudio Leandro Afonso <claudio-leandro3@knights.ucf.edu>
Sent: Thursday, April 18, 2019 4:20 PM
To: BB.Info.LI <BB.Info.LI@advantech.com>
Subject: Citation Permissions

Hello,

My name is Claudio Afonso, and I am a senior majoring in Computer Engineering at the University of Central Florida. My group and I are working on a senior design project, and we would like to cite and use pictures from your website in our project report.

I was wondering whether it is fine with you.

Claudio Afonso
Computer Engineering 2019
University of Central Florida
claudio-leandro3@knights.ucf.edu
+1-407-924-1443

AWS Response

 Tammy Roberts <tamrob@amazon.com>
Fri 4/19, 8:58 AM
Claudio Leandro Afonso: curryme@amazon.com

Flag for follow up.

Good Morning Claudio-

I've confirmed that there's no issue with citing the AWS website and diagrams in your project report as long as it's properly cited so go for it!

A parting thought - If you haven't discovered our AWS Educate program yet, I encourage you to check it out. <https://aws.amazon.com/education/awseducate/> Students receive credits for hands on experience with AWS technology, training, content, career pathways, and AWS Educate Job Board.

Thanks for your interest in AWS. Wishing you the best!
Tam-

Tammy Roberts
Enterprise Higher Education Team
Amazon Web Services
e: tamrob@amazon.com
c: 770.688.9569

 AWS_logo_RGB

AWS Cloud for Higher Education <https://aws.amazon.com/education/higher-ed/>
Visit: [AWS Marketplace for Healthcare and Life Sciences | UCLG Solutions](https://aws.amazon.com/education/higher-ed/)

Citation Permission

 Jane Mohr <jmohr@logic-control.com>
Fri 4/19, 9:42 AM

Hi Claudio,
Thanks for your email. You can use pictures, please cite our website. Would send me a copy of your project report? I would love to see how Logic, Inc. site was used.

Best regards,

Jane Mohr

[Report inappropriate text](#)

 Claudio Leandro Afonso
Thu 4/18, 5:16 PM
sales@logic-control.com

Hello,

My name is Claudio Afonso, and I am a senior majoring in Computer Engineering at the University of Central Florida. My group and I are working on a senior design project, and we would like to cite and use pictures from your website in our project report.

I was wondering whether it is fine with you.

Thank you,
Claudio Afonso
Computer Engineering 2019
University of Central Florida
claudio-leandro3@knights.ucf.edu
+1-407-924-1443

Citation Permission

 SparkFun Customer Service <cservice@sparkfun.com>
Fri 4/19, 11:49 AM
Claudio Leandro Afonso

[Flag for follow up.](#)

Type your response ABOVE THIS LINE to reply

Claudio Leandro Afonso
Subject: Citation Permission

APR 19, 2019 | 09:48AM MDT

Anna C replied:

Hello,

Thank you for reaching out.

As we are an open source company you are welcome to use the information on our site we just ask that you properly cite us and our photographer, Juan Peña.

Have a great day!

Anna Carlson
Customer Service
SparkFun Electronics
303.284.0679

APR 19, 2019 | 09:04PM MDT

Original message

Claudio wrote:

Hello,

My name is Claudio Afonso, and I am a senior majoring in Computer Engineering at the University of Central Florida. My group and I are working on a senior design project, and we would like to cite your website in our project report.

I was wondering whether it is fine with you.

Thank you,

Claudio Afonso

Computer Engineering 2019

University of Central Florida

claudio-leandro3@knights.ucf.edu

+1-407-924-1443

[This message was sent to claudio-leandro3@knights.ucf.edu in reference to Case #: 349527.](#)

 Claudio Leandro Afonso

Hello, My name is Claudio Afonso, and I am a senior majoring in Computer Engineering at the University of Central Florida. My group and I are working on a senior design project, and we would like to cite your website in our project report. I was wondering whether

Citation Permission

 courtney.kessel@leafgroup.com on behalf of Partner Channel Feedback <partner.channelfeedback@leafgroup.com>
Fri 4/19, 11:54 AM

Hello,
You are welcome to cite info from a specific article however please do not use any images. Please abide by the following guidelines:

1. Don't use any images
2. Verify the publication is print only (or some medium not through search engines, like email)
3. Use proper attribution like so:

Marketing Ideas for a Land Surveying Company (CHANGE TO TITLE NAME)
Felicia Greene, Leaf Group (CHANGE TO THE APPROPRIATE AUTHOR)
© 2019 Leaf Group, Ltd. U.S.A. All rights reserved.

We appreciate your interest in our article. Please let us know if you have any other questions.

Thank you.



 Claudio Leandro Afonso
Thu 4/18, 10:19 PM
hello@sciencing.com

To help protect your privacy, some content in this message has been blocked. To re-enable the blocked features, click here.
To always show content from this sender, click here.

Hello,

My name is Claudio Afonso, and I am a senior majoring in Computer Engineering at the University of Central Florida. My group and I are working on a senior design project, and we would like to cite and use pictures from your website in our project report. I was wondering whether it is fine with you.

Thank you,
Claudio Afonso
Computer Engineering 2019
University of Central Florida
claudio-leandro3@knights.ucf.edu
+1-407-924-1443

 Claudio Leandro Afonso
Thu 4/18, 4:48 PM
editor@inspectAPedia.com

  Reply all | 

Hello,

My name is Claudio Afonso, and I am a senior majoring in Computer Engineering at the University of Central Florida. My group and I are working on a senior design project that involves RV HVAC, and we would like to cite your website and use pictures of your products in our project report.

I was wondering whether it is fine with you.

Claudio Afonso
Computer Engineering 2019
University of Central Florida
claudio-leandro3@knights.ucf.edu
+1-407-924-1443



"Lubrication-Enabled Reliability"

[About Us](#)
[International Products & Services](#)
[Contact Us](#)

[Home](#)
[Education & Training](#)
[Services](#)
[Publishing](#)
[Conferences](#)
[Store](#)



Contact Us



Corporate Office
1328 E. 43rd Court
Tulsa, OK 74105

General Information
Toll Free US: 800-597-5460
Phone: 918-749-1400
Fax: 918-746-0925

Contact Numbers

Training/Consulting/Services/Sales
918-392-5063

Online Training Support
918-392-5068

Training Registration
918-392-5038

Bookstore
918-392-5032

Thank you for your interest in Noria Corporation. Please tell us how we can help by filling out this quick form. A Noria representative will contact you shortly. If you require an immediate response to your question or comment, please call us at the appropriate number listed above.

First Name*

Last Name*

Email*

Company Name

Country*

United States 

Contact Me About*
(Select the Option that Best Applies)

Training, Consulting, Services or Sales Training Registration

Online Training Support Mailing List

Machinery Lubrication Tech Support Oil Analysis Tech Support

Accounting Advertising Enterprise Solutions

Bookstore

Comments or Questions?

Hello,

My name is Claudio Afonso, and I am a senior majoring in Computer Engineering at the University of Central Florida. My group and I are working on a senior design project, and we would like to cite and use pictures from your website in our project report.

I was wondering whether it is fine with you.

Thank you, 

W WYCKOFF
HEATING & COOLING

Who We Are ▾ Services ▾ Financing Employment ▾

Service Type*

Residential Commercial

Please describe the problem:*

Hello,
My name is Claudio Afonso, and I am a senior majoring in Computer Engineering at the University of Central Florida. My group and I are working on a senior design project, and we would like to cite and use pictures from your website in our project report!
I was wondering whether it is fine with you.

Thank you,
Claudio Afonso

When is the best time to reach you?*

Morning Afternoon Evening

What is the best way to reach you?*

Phone Email

SUBMIT

 **ARISTA**

Company Services Commercial

Street Address

4000 Central Florida Blvd, Orlando, FL 32816

City State* Postal Code

Orlando Florida 32826

Country*

United States

Email* Phone Number*

claudio-leandro3@knights.ucf.edu 4079241443

Tell Us What You Need:

My name is Claudio Afonso, and I am a senior majoring in Computer Engineering at the University of Central Florida. My group and I are working on a senior design project, and we would like to cite and use pictures from your website in our project report.

I was wondering whether it is fine with you.

You may unsubscribe from these communications at any time. For more information on how to unsubscribe, our privacy practices, and how we are committed to protecting and respecting your privacy, please review our [Privacy Policy](#).

SUBMIT

✓ RoHS Guide

[Home](#) | [Software](#) | [FAQ](#) | [Categories](#) | [Substances](#) | [GH](#)



AdChoices
reporting software
rohs certificate

Contact Us

To contact us, please fill out the short form below:

Name:

Email: *

My name is Claudio Afonso, and I am a senior majoring in Computer Engineering at the University of Central Florida. My group and I are working on a senior design project, and we would like to cite your website in our project report.

I was wondering whether it is fine with you.

Message: *

EPSNews

[HOME](#) | [NEWS ANALYSIS](#) | [DISTRIBUTION](#) | [SUPPLY CHAIN](#)



EU Expects Electronics Employment Squeeze
March 27, 2019



How Sensors & Networks are Empowering Agriculture Technology
March 22, 2019

Leave Comment

Your email address will not be published. Required fields are marked *

My name is Claudio Afonso, and I am a senior majoring in Computer Engineering at the University of Central Florida. My group and I are working on a senior design project, and we would like to cite and use pictures from your website in our project report.

I was wondering whether it is fine with you.

ASPENCORE

[MEDIA](#) | [DATA](#) | [TOOLS](#) | [CREATIVE](#) | [CONTACT](#)

Contact Us

If you are interested in working with us then please drop us a line, we would love to hear from you.

FIRST NAME <input style="width: 95%;" type="text" value="Claudio"/>	LAST NAME <input style="width: 95%;" type="text" value="Afonso"/>
COMPANY <input style="width: 95%;" type="text" value="UCF"/>	COMPANY TYPE <input style="width: 95%;" type="text" value="Select..."/>
EMAIL <input style="width: 95%;" type="text" value="claudio-leandro3@knights.ucf.edu"/>	PHONE <input style="width: 95%;" type="text" value="4079242443"/>
COUNTRY <input style="width: 95%;" type="text" value="United States"/>	STATE <input style="width: 95%;" type="text" value="FL"/>
INQUIRY TYPE <input style="width: 95%;" type="text" value="Advertising with Us"/>	
YOUR MESSAGE <input style="width: 95%; height: 40px;" type="text" value="My name is Claudio Afonso, and I am a senior majoring in Computer Engineering at the University of Central Florida. My group and I are working on a senior design project, and we would like to cite and use pictures from your website in our project report."/>	



Download FREE
• Scher
• PCB f
• 3D mo

- HOME
- NEWS
- OPERATIONS
- RESOURCES
- ABOUT
- NEWSLETTER

NEWS TICKER > [April 16, 2019] 3 Keys to Every Digital Supply Chain [In Order to Overcome Volatility and

HOME > Contact Us

Contact Us

Contact Us

Fields marked with an * are required

Name *

Claudio Afonso

Email *

claudio-leandro3@knights.ucf.edu

Country *

United States

Phone

4079241443

Message *

My name is Claudio Afonso, and I am a senior majoring in Computer Engineering at the University of Central Florida. My group and I are working on a senior design project, and we would like to cite and use pictures from your website in our project report.

I was wondering whether it is fine with you.

SENSAPHONE
REMOTE MONITORING SOLUTIONS

PRODUCTS INDUSTRIES SUPPORT CONTACT

Company Name

University of Central Florida

First Name*

Claudio

Last Name*

Afonso

Job Title

Computer Engineer Senior Student

Street Address

4000 Central Florida Blvd

City

Orlando

State/Region

Florida

Postal Code

32816

Country

USA

Phone Number

+14079241443

Email*

claudio-leandro3@knights.ucf.edu

Which of the following industries are you most closely involved with*

Data Center

Questions or Comments

Hello,

My name is Claudio Afonso, and I am a senior majoring in Computer Engineering at the University of Central Florida. My group and I are working on a senior design project that involves RV HVAC, and we would like to cite and use pictures of your products in our project report.

I was wondering whether it is fine with you.

SUBMIT

To: editor@inspectAPedia.com

Cc:

Citation Permissions

Hello,

My name is Claudio Afonso, and I am a senior majoring in Computer Engineering at the University of Central Florida. My group and I are working on a senior design project that involves RV HVAC, and we would like to cite your website and use pictures of your products in our project report.

I was wondering whether it is fine with you.

Claudio Afonso
Computer Engineering 2019
University of Central Florida
claudio-leandro3@knights.ucf.edu
+1-407-924-1443

Send Discard Draft saved at 4:47 PM

Support Center

Ionic / Submit a request

Submit a request

What is this issue regarding?

General Support

Your email address *

Claudio Afonso

Subject *

Permission to Cite Your Website

Suggested articles

- [Managing plugins using CocoaPods in Ionic Appflow](#)
- [Adding execute permissions using git](#)
- [Package build fails with error "CordovaError: Using "requireCordovaModule""](#)
- [GitHub integration with Ionic Appflow](#)
- [Android builds fail due to missing jcenter dependencies](#)
- [Bitbucket Cloud Integration with Ionic Appflow](#)
- [Installing the Ionic CLI without sudo](#)
- [Troubleshooting iOS Code Signing Issues in Package](#)
- [iOS package build fails with fastlane error: "Couldn't find specified scheme"](#)

Description *

Hello,

My name is Claudio Afonso, and I am a senior majoring in Computer Engineering at the University of Central Florida. My group and I are working on a senior design project, and we would like to cite and use pictures of your products in our project report.

I was wondering whether it is fine with you.

Thank you,
Claudio Afonso

ionic support Support Center

ionic / Submit a request

Submit a request

What is this issue regarding?
General Support

Your email address *
claudio-leandro3@knights.ucf.edu
Requester Email: claudio afonso is not properly formatted

Subject *
Permission to Cite Your Website

Description *
Hello,
My name is Claudio Afonso, and I am a senior majoring in Computer Engineering at the University of Central Florida. My group and I are working on a senior design project, and we would like to cite and use pictures of your products in our project report.
I was wondering whether it is fine with you.
Thank you,
Claudio Afonso

Please enter the details of your request. A member of our support staff will respond as soon as possible.

ALERT LABS

Alert Labs > Submit a request

SUBMIT A REQUEST

Your email address *
claudio-leandro3@knights.ucf.edu

Name *
Claudio Afonso

Subject *
Permission to Cite Your Website

Suggested articles

- Will Flowie affect my water meter reading?
- Prevent and treat floods
- Making water conservation easy
- Will Flowie work on a compound water meter?
- Resetting your password
- Frequently Asked Questions
- Finding a leak
- I forgot my password
- What if I can't get a good cellular signal?
- How will my order ship?

Description *
Hello,
My name is Claudio Afonso, and I am a senior majoring in Computer Engineering at the University of Central Florida. My group and I are working on a senior design project, and we would like to cite your website and use pictures of your products in our project report.
I was wondering whether it is fine with you.
Thank you,
Claudio Afonso

Please enter the details of your request. A member of our support staff will respond as soon as possible.

Looking for
PLUMBING & ELECTRICAL?

GEORGE BRAZIL
24-HR SERVICE SINCE 1948
Air Conditioning • Heating

HOME ABOUT AIR CONDITIONING HEATING BLOG EM

Send Us an Email

Do you have a general question or comment for us? Use the form below.

If you want to schedule an appointment for a repair, estimate or other service, [please use this form](#). For emergency services, please call (602) 842-0009.

Name *
Claudio Afonso
First Last

Email *
claudio-leandro3@knights.ucf.edu

Phone *
4079241443

Question or comment *
Hello,
My name is Claudio Afonso, and I am a senior majoring in Computer Engineering at the University of Central Florida. My group and I are working on a senior design project, and we would like to cite your website and use pictures of your products in our project report.
I was wondering whether it is fine with you.
Thank You

Send

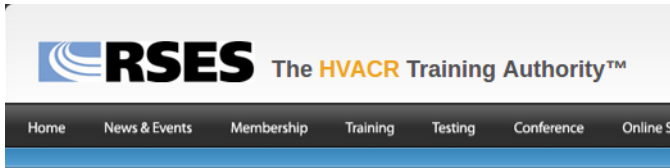

Home > Contact Print

Contact Us

We welcome your questions and comments. Please complete the below contact form to reach one of our

> indicates required field

Prefix

First Name

Middle Initial

Last Name

Preferred Mailing Address Home Address Business Address

Company

Address 1

Address 2

Address 3

City

State/Province

ZIP/Postal Code

Country

Phone

Email

Confirm Email

Send me a catalog Yes No

Primary Business

Primary HVACR Role

How did you hear about us?

Inquiry Type

Your Message

howstuffworks
 Health Science Home & Garden Auto Tech Culture Money Lifestyle Entertainment Adventure

CONTACT US

If you would like to contact the hosts of one of our podcasts, please use the email address given at the end of each episode. Otherwise, to contact our team, please use the form below.

Please note that we do not accept or publish unsolicited articles or other content.

Thank!

Reason:

Your Name: Your E-mail:

Message:

(400 character limit)

howstuffworks
Health Science Home & Garden Auto Tech Culture Money Lifestyle Entertainment Adventure

CONTACT US

If you would like to contact the hosts of one of our podcasts, please use the email address given at the end of each episode. Otherwise, to contact our team, please use the form below.

Please note that we do not accept or publish unsolicited articles or other content.

Thanks!

Reason:
Advertise with us

Your Name: Claudio Afonso
Your E-mail: claudio-leandro3@knights.ucf.edu

Message:
Hello,

My name is Claudio Afonso, and I am a senior majoring in Computer Engineering at the University of Central Florida. My group and I are working on a senior design project, and we would like to cite and use pictures from your website in our project report.

I was wondering whether it is fine with you.

Thank you,
Claudio Afonso

(400 character limit)

Message has been sent successfully.

Send the Message

How an A/C Compressor Works

229,738 views

6.6K 138 SHARE SAVE ...



speedkar99

Published on Sep 1, 2018

SUBSCRIBE 108K

Here's what's inside of an automotive air condition compressor and how it works to cool the interior of your car.

SHOW MORE

Buy speedkar99 merchandise

863 Comments SORT BY



Hi! My name is Claudio Afonso, and I am a senior majoring in Computer Engineering at the University of Central Florida. My group and I are working on a senior design project, and we would like to cite your video. I was wondering whether it is fine with you.



How an A/C Compressor Works

229,738 views

6.6K 138 SHARE SAVE ...



speedkar99

Published on Sep 1, 2018

SUBSCRIBE 108K

Here's what's inside of an automotive air condition compressor and how it works to cool the interior of your car.

SHOW MORE

Buy speedkar99 merchandise

863 Comments SORT BY



Hi! My name is Claudio Afonso, and I am a senior majoring in Computer Engineering at the University of Central Florida. My group and I are working on a senior design project, and we would like to cite your video. I was wondering whether it is fine with you.

CANCEL

COMMENT



How an A/C Compressor Works

229,738 views

6.6K 138 SHARE SAVE ...



speedkar99
Published on Sep 1, 2018

SUBSCRIBE 108K

Here's what's inside of an automotive air condition compressor and how it works to cool the interior of your car.

SHOW MORE

Buy speedkar99 merchandise

863 Comments SORT BY



Add a public comment...



Claudio Afonso 1 second ago

Hi! My name is Claudio Afonso, and I am a senior majoring in Computer Engineering at the University of Central Florida. My group and I are working on a senior design project, and we would like to cite your video. I was wondering whether it is fine with you.

REPLY

How a Car's HVAC System Works

161,899 views

2.7K 68 SHARE SAVE ...



speedkar99
Published on May 12, 2017

SUBSCRIBE 108K

Here's how an automotive heat, ventilation and air conditioning system works.

The HVAC system in a car is situated under the dashboard and controls the heat and cooling

SHOW MORE

Buy speedkar99 merchandise

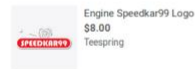

389 Comments SORT BY



Add a public comment...



Claudio Afonso 1 second ago

Hi! My name is Claudio Afonso, and I am a senior majoring in Computer Engineering at the University of Central Florida. My group and I are working on a senior design project, and we would like to cite your video. I was wondering whether it is fine with you.

REPLY

Citation Permissions



Claudio Leandro Afonso
Thu 4/18, 4:51 PM
chris@bryantrv.com

👤 🗉 ↻ Reply all | ▾

Hello,

My name is Claudio Afonso, and I am a senior majoring in Computer Engineering at the University of Central Florida. My group and I are working on a senior design project, and we would like to cite your website and use pictures of your products in our project report.

I was wondering whether it is fine with you.

Thank You
Claudio Afonso
Computer Engineering 2019
University of Central Florida
claudio-leandro3@knights.ucf.edu
+1-407-924-1443

Citation Permission



Claudio Leandro Afonso
Thu 4/18, 4:58 PM
phoffman@swtc.edu

👤 🗉 ↻ Reply all | ▾

Dear Mr. Hoffman,

My name is Claudio Afonso, and I am a senior majoring in Computer Engineering at the University of Central Florida. My group and I are working on a senior design project, and we would like to cite and use pictures from your website in our project report.

I was wondering whether it is fine with you.

Claudio Afonso
Computer Engineering 2019
University of Central Florida
claudio-leandro3@knights.ucf.edu
+1-407-924-1443

Citation Permission



Claudio Leandro Afonso
Thu 4/18, 5:11 PM
motleyvrrepair@coxinet.net

👤 🗉 ↻ Reply all | ▾

Hello,

My name is Claudio Afonso, and I am a senior majoring in Computer Engineering at the University of Central Florida. My group and I are working on a senior design project, and we would like to cite and use pictures from your website in our project report.

I was wondering whether it is fine with you.

Claudio Afonso
Computer Engineering 2019
University of Central Florida
claudio-leandro3@knights.ucf.edu
+1-407-924-1443

Citation Permissions



Claudio Leandro Afonso
Thu 4/18, 5:20 PM
info@advantech-bb.com

👤 🗉 ↻ Reply all | ▾

Hello,

My name is Claudio Afonso, and I am a senior majoring in Computer Engineering at the University of Central Florida. My group and I are working on a senior design project, and we would like to cite and use pictures from your website in our project report.

I was wondering whether it is fine with you.

Claudio Afonso
Computer Engineering 2019
University of Central Florida
claudio-leandro3@knights.ucf.edu
+1-407-924-1443

Citation Permission



Claudio Leandro Afonso
Thu 4/18, 5:22 PM
info@lammertbies.nl

👤 🗨️ Reply all | ▾

Hello,

My name is Claudio Afonso, and I am a senior majoring in Computer Engineering at the University of Central Florida. My group and I are working on a senior design project, and we would like to cite and use pictures from your website in our project report.

I was wondering whether it is fine with you.

Thank you,
Claudio Afonso
Computer Engineering 2019
University of Central Florida
claudio-leandro3@knights.ucf.edu
+1-407-924-1443

Citation Permission



Claudio Leandro Afonso
Thu 4/18, 5:24 PM
Technology@mansfieldct.org

👤 🗨️ Reply all | ▾

Dear Mr. Russel,

My name is Claudio Afonso, and I am a senior majoring in Computer Engineering at the University of Central Florida. My group and I are working on a senior design project, and we would like to cite and use pictures from your website in our project report.

I was wondering whether it is fine with you.

Thank you,
Claudio Afonso
Computer Engineering 2019
University of Central Florida
claudio-leandro3@knights.ucf.edu
+1-407-924-1443

Citation Permission



Claudio Leandro Afonso
Thu 4/18, 9:56 PM
editor@inspectapedia.com

👤 🗨️ Reply all | ▾

Hello,

My name is Claudio Afonso, and I am a senior majoring in Computer Engineering at the University of Central Florida. My group and I are working on a senior design project, and we would like to cite and use pictures from your website in our project report.

I was wondering whether it is fine with you.

Thank you,
Claudio Afonso
Computer Engineering 2019
University of Central Florida
claudio-leandro3@knights.ucf.edu
+1-407-924-1443



Claudio Leandro Afonso
Thu 4/18, 10:28 PM
epubs@purdue.edu

👤 🗑️ 🔄 Reply all | ▾

Hello,

My name is Claudio Afonso, and I am a senior majoring in Computer Engineering at the University of Central Florida. My group and I are working on a senior design project, and we would like to cite and use pictures from article, "The Noise and Vibration Characteristics of a Reciprocating Compressor: Effects of Size and Profile of Discharge Port," in our project report.

I was wondering whether it is fine with you.

Thank you,

Claudio Afonso

Computer Engineering 2019

University of Central Florida

claudio-leandro3@knights.ucf.edu

+1-407-924-1443

Citation Permission



Claudio Leandro Afonso
Thu 4/18, 10:33 PM
BXue@ahrinet.org

👤 🗑️ 🔄 Reply all | ▾

Hello,

My name is Claudio Afonso, and I am a senior majoring in Computer Engineering at the University of Central Florida. My group and I are working on a senior design project, and we would like to cite and use pictures from your website in our project report.

I was wondering whether it is fine with you.

Thank you,

Claudio Afonso

Computer Engineering 2019

University of Central Florida

claudio-leandro3@knights.ucf.edu

+1-407-924-1443

From claudio-leandro3@Knights.ucf.edu

Bcc

To info@freedomhvocal.com

Cc

Citation Permission

Hello,

My name is Claudio Afonso, and I am a senior majoring in Computer Engineering at the University of Central Florida. My group and I are working on a senior design project, and we would like to cite and use pictures from your website in our project report.

I was wondering whether it is fine with you.

Thank you,

Claudio Afonso

Computer Engineering 2019

University of Central Florida

claudio-leandro3@knights.ucf.edu

+1-407-924-1443

Citation Permission



Claudio Leandro Afonso
Thu 4/18, 10:44 PM
applications.engineering@digikey.com

Reply all | v

Hello,

My name is Claudio Afonso, and I am a senior majoring in Computer Engineering at the University of Central Florida. My group and I are working on a senior design project, and we would like to cite and use pictures from your website in our project report.

I was wondering whether it is fine with you.

Thank you,
Claudio Afonso
Computer Engineering 2019
University of Central Florida
claudio-leandro3@knights.ucf.edu
+1-407-924-1443



Claudio Leandro Afonso
Thu 4/18, 10:47 PM
margaritis.schinas@ec.europa.eu

Reply all | v

Hello,

My name is Claudio Afonso, and I am a senior majoring in Computer Engineering at the University of Central Florida. My group and I are working on a senior design project, and we would like to cite and use pictures from your website in our project report.

I was wondering whether it is fine with you.

Thank you,
Claudio Afonso
Computer Engineering 2019
University of Central Florida
claudio-leandro3@knights.ucf.edu
+1-407-924-1443

Citation Permission



Claudio Leandro Afonso
Thu 4/18, 10:52 PM
P65.Questions@oehha.ca.gov

Reply all | v

Hello,

My name is Claudio Afonso, and I am a senior majoring in Computer Engineering at the University of Central Florida. My group and I are working on a senior design project, and we would like to cite your website in our project report.

I was wondering whether it is fine with you.

Thank you,
Claudio Afonso
Computer Engineering 2019
University of Central Florida
claudio-leandro3@knights.ucf.edu
+1-407-924-1443

Citation Permission



Claudio Leandro Afonso
Thu 4/18, 10:56 PM
prop-65-claim-notice@amazon.com

Reply all | v

Hello,

My name is Claudio Afonso, and I am a senior majoring in Computer Engineering at the University of Central Florida. My group and I are working on a senior design project, and we would like to cite your product description (from the amazon website) in our project report.

I was wondering whether it is fine with you.

Thank you,
Claudio Afonso
Computer Engineering 2019
University of Central Florida
claudio-leandro3@knights.ucf.edu
+1-407-924-1443

Claudio Leandro Afonso
Subject: Citation Permission

APR 19, 2019 | 09:48AM MDT

Anna C replied:

Hello,

Thank you for reaching out.

As we are an open source company you are welcome to use the information on our site we just ask that you properly cite us and our photographer, Juan Peña.

Have a great day!

Anna Carlson
Customer Service
SparkFun Electronics
303.284.0979

APR 19, 2019 | 09:04PM MDT

Original message

Claudio wrote:

Hello,

My name is Claudio Afonso, and I am a senior majoring in Computer Engineering at the University of Central Florida. My group and I are working on a senior design project, and we would like to cite your website in our project report.

I was wondering whether it is fine with you.



Thank you,

Claudio Afonso

Citation Permission



Claudio Leandro Afonso
Thu 4/18, 11:06 PM
tariffs@digikey.com

  Reply all | 

Hello,

My name is Claudio Afonso, and I am a senior majoring in Computer Engineering at the University of Central Florida. My group and I are working on a senior design project, and we would like to cite your website in our project report.

I was wondering whether it is fine with you.

Thank you,

Claudio Afonso
Computer Engineering 2019
University of Central Florida
claudio-leandro3@knights.ucf.edu
+1-407-924-1443

 **elliottwilliams@hackaday.com**
Fri 4/19, 3:24 PM



Hi Claudio,

I'm not sure what you mean by cite, but if you simply mean to say that you found something here, absolutely! We love it when people who learn something from Hackaday share it as a resource.

What exactly did you have in mind?

Best,
Elliot.

Elliot Williams
Managing Editor, Hackaday.com

 **Claudio Leandro Afonso**
Thu 4/18, 11:07 PM
editor@hackaday.com

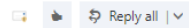

> Hello,
>
> My name is Claudio Afonso, and I am a senior majoring in Computer Engineering at the University of Central Florida. My group and I are working on a senior design project, and we would like to cite your website in our project report.
>
> I was wondering whether it is fine with you.
>
> Thank you,
>
> Claudio Afonso
>
> Computer Engineering 2019
>
> University of Central Florida
>
> claudio-leandro3@knights.ucf.edu
>
> +1-407-924-1443



Company Services Commercial

Name Company
Claudio Afonso University of Central Florida

Street Address
4000 Central Florida Blvd

City State* Postal Code
Orlando Florida 32816

Country*
United States

Email* Phone Number*
claudio-leandro3@knights.ucf.edu +14079241443

Tell Us What You Need:
Hello,
Hi! My name is Claudio Afonso, and I am a senior majoring in Computer Engineering at the University of Central Florida. My group and I are working on a senior design project, and we would like to cite and use pictures from your website in our project report. I was wondering whether it is fine with you.
Thank you,
Claudio Afonso

You may unsubscribe from these communications at any time. For more information on how to unsubscribe, our privacy practices, and how we are committed to protecting and respecting your privacy, please review our [Privacy Policy](#).

SUBMIT

Appendix B – References

“Cloud Services/content,” Development and Design of Web Pages in Guatemala, 28-Nov-2018. [Online]. Available: <https://www.whereinguate.com/cloud-services-content/>. [Accessed: 19-Mar-2019].

A. Fuller, “AWS Cloud Map: Easily create and maintain custom maps of your applications | Amazon Web Services,” Amazon, 30-Nov-2018. [Online blog]. Available: <https://aws.amazon.com/blogs/aws/aws-cloud-map-easily-create-and-maintain-custom-maps-of-your-applications/>. [Accessed: 19-Mar-2019].

W. Neu, “ETL Job Orchestration with Matillion, Amazon DynamoDB, and AWS Lambda | Amazon Web Services,” Amazon, 03-May-2018. [Online blog]. Available: <https://aws.amazon.com/blogs/database/etl-job-orchestration-with-matillion-amazon-dynamodb-and-aws-lambda/>. [Accessed: 19-Mar-2019].

Ionicframework, “What is Ionic,” Ionic Framework. [Online]. Available: <https://ionicframework.com/what-is-ionic>. [Accessed: 20-Mar-2019].

“Bluetooth,” Wikipedia: The Free Encyclopedia [Online], Available: https://en.wikipedia.org/wiki/Bluetooth#Bluetooth_protocol_stack. [Accessed: 20-Mar-2019].

“RS-485,” Wikipedia: The Free Encyclopedia [Online], Available: <https://en.wikipedia.org/wiki/RS-485>. [Accessed: 20-Mar-2019].

“Sentree A/C Monitoring System,” Alert Labs [Online], Available: <https://alertlabs.com/pages/sentree>. [Accessed: 20-Mar-2019].

“HVAC Monitoring System,” Sensaphone Remote Monitoring Solutions [Online], Available: <https://www.sensaphone.com/industries/hvac.php>. [Accessed: 20-Mar-2019]

D. Friedman, “A/C Air Temperature Measurement Procedures How to Make Air Conditioning System Temperature Measurements,” InspectApedia. [Online]. Available: https://inspectapedia.com/aircond/Air_Conditioner_Temperature_Measurement.php. [Accessed: 22-Mar-2019].

D. Friedman, “How & Where to Measure Central Air Conditioning Temperatures,” InspectApedia. [Online]. Available: https://inspectapedia.com/aircond/Air_Conditioner_Temperature_Measurement.php. [Accessed: 22-Mar-2019].

F. Prah, “REFRIGERANT 410A.” Refrigeration Service Engineers Society.

C. Bryant, "Troubleshooting," R.V. Air Conditioner Troubleshooting. [Online]. Available: <http://bryantrv.com/roofac2.html>. [Accessed: 21-Mar-2019].

Quality Home Maintenance, "What Temperature Should My Central Air Conditioner Be Putting Out?," Air Conditioning, 07-Jul-2017. .

J. Tomczyk, "The Professor: Condensing Temperatures and Condensing Splits," The News, BNP Media, 02-Jul-2012.

N. Christopherson, "Superheat And Subcooling Made Simple," The News, BNP Media, 11-Jan-2004.

"Expansion Valve," in Ag Power Web Enhanced Course Materials.

"R-410A Pressure-temperature chart." Bonneville Power Administration, Portland.

"The Essentials Of Working With R-410A." .

G. Motley, "RV Air Conditioners Made Simple," Motley RV Repair, Feb-2004. .

Sam, "Refrigerator Pressure Drop," Refrigerator Troubleshooting Diagram, 08-Nov-2009. .

C. Yang, "The Secrets of RS-485 Half-duplex Communication." Moxa, 28-Sep-2009.

B B SmartWorx, "RS-422 AND RS-485 APPLICATIONS EBOOK A Practical Guide to Using RS-422 and RS-485 Serial Interfaces." B B SmartWorx, Ottawa, Oct-2010.

L. Bies, "RS485 serial information," RS485, specifications and in depth tutorial. [Online]. Available: <https://www.lammertbies.nl/comm/info/RS-485.html#topo>. [Accessed: 23-Mar-2019].

L. Bies, "RS422 serial information," RS422, specifications and in depth tutorial. [Online]. Available: <https://www.lammertbies.nl/comm/info/RS-422.html#intr>. [Accessed: 23-Mar-2019].

How a refrigerator works: [Online]. Available: <https://www.mansfieldct.org/Schools/MMS/staff/hand/heatrefrig.htm>. [Accessed: 23-Mar-2019].

M. Brian and S. Elliot, "How Refrigerators Work." .

M. Brian, C. W. Bryant and S. Elliot, "How Air Conditioners Work.".

speedkar99, How an A/C Compressor Works, 01-Sep-2018. [Online]. Available: <https://www.youtube.com/watch?v=urFVLKlpf1I>. [Accessed: 23-Mar-2019].

speedkar99, How a Car's HVAC System Works, 12-May-2017. [Online]. Available: <https://www.youtube.com/watch?v=04MITepElz4>. [Accessed: 23-Mar-2019].

M. C. Rosone, "8 Preventable Causes of AC Compressor Failure," 21-Apr-2015. .

D. Friedman, "A/C Air Temperature Measurement Procedures," InspectApedia. [Online]. Available: https://inspectapedia.com/aircond/Air_Conditioner_Temperature_Measurement.php. [Accessed: 24-Mar-2019].

The News, "Troubleshooting With Compressor Amperage," The News, BNP Media, 31-Mar-2005.

L. Reynolds, "What Is a Condensing Unit?," Sciencing, 24-Apr-2017. .

J. Wright, "What Causes Machinery Vibration?," Machinery Lubrication , Noria, Jul-2010.

H. Erol and A. Gurdogan, "The Noise and Vibration Characteristics of a Reciprocating Compressor: Effects of Size and Profile of Discharge Port." Purdue University Purdue e-Pubs, 2000.

W. Davis, "HVAC System Performance Testing." ACCA, Lansdowne, 24-Mar-2009.

A. Wyckoff, "5 Common Causes of Air Conditioning Failure – What you can do and when to call a Technician," Wyckoff Heating & Cooling, 13-Aug-2018. [Online]. Available: <https://wyckoffcomfort.com/2015/07/5-common-causes-of-air-conditioning-failure>. [Accessed: 24-Mar-2019].

M. C. Rosone, "5 Symptoms of AC Compressor Failure," 15-Aug-2017. .

"Top 9 Air Conditioning Problems and Solutions," Freedom Heating & Air, 21-Nov-2017. [Online]. Available: <https://www.freedomhvacal.com/technical-hvac/blog-air-conditioning-problems/>. [Accessed: 24-Mar-2019].

Digi-Key, "Programmable SoCs Help Manufacturers Find the Right Balance Between Configurability and Performance," Digi-Key, 24-Oct-2017. .

"The RoHS Directive," Electrical and electronic waste - Environment - European Commission. N.d. [Online]. Available:

http://ec.europa.eu/environment/waste/rohs_eee/index_en.htm. [Accessed: 24-Mar-2019].

“New Proposition 65 Warnings,” [p65warnings.ca.gov](https://www.p65warnings.ca.gov). [Online]. Available: <https://www.p65warnings.ca.gov/new-proposition-65-warnings>. [Accessed: 24-Mar-2019].

“About California Proposition 65,” Amazon. [Online]. Available: <https://www.amazon.com/gp/help/customer/display.html?ie=UTF8&nodeId=3234041>. [Accessed: 24-Apr-2019].

B. Jorgensen, “Tariffs Raise ‘Red Flag’ on Component Supply Risks,” EPS News, BBG Enterprises, 06-Aug-2018.

D. McGrath, “New China Tariffs Hit Chip Industry Again,” EE Times, AspenCore, 18-Sep-2018.

G. Alexander, “The Impact of U.S. Import Tariffs on the Availability of Electronic Components,” Part Procurer, Insomnicat Media, 16-Jan-2019.

B. Benchoff, “ELECTRONICS MANUFACTURERS REACT TO CHINA TRADE TARIFFS,” Hackaday, 02-Jul-2018. .

M. Arnold, “Summer of Tariffs The impact of managing uncertainty with a catalog of 2,400 storefront SKUs,” Sparkfun, 24-Jul-2018. .

D. Doherty, “Letter to Customers,” Digi-Key, Digi-Key, 13-Sep-2018.

“IEEE Recommended Practice for Software Requirements Specifications.” IEEE Computer Society, New York, 20-Oct-1998.

“Degrees of Protection Provided by Enclosures.” National Electrical Manufacturers Association, Rosslyn, 03-Nov-2004.

“LEC's protection rating: IP67, IP68, IP69,” LEC, 16-Feb-2016. [Online]. Available: <https://www.lec-expert.com/topics/lecs-protection-rating-ip67-ip68-ip69>. [Accessed: 25-Mar-2019].

“IP Code,” Wikipedia: The Free Encyclopedia [Online], Available: https://en.wikipedia.org/wiki/IP_Code. [Accessed: 25-Mar-2019].

“Service - Enclosure Ratings,” IP69K Rating Enclosure IP66 IP65 IP68 Meanings. [Online]. Available: <https://www.centralcarolinascale.com/IP66.htm>. [Accessed: 26-Mar-2019].