

Home Safety and Automation System

Senior Design I – EEL 4914

Summer 2019 – Fall 2019



UNIVERSITY OF CENTRAL FLORIDA

Group 14

Avery Stevenson – Photonic Science and Engineering

Felix Henriquez – Computer Engineering

Guilherme Costa – Computer Engineering

Matthew Allen – Computer Engineering

This Page Is Intentionally Left Blank

Table of Contents

1. Executive Summary.....	1
2. Project Description	2
2.1. Project Motivation.....	2
2.2. Goals & Objectives	2
2.3. Requirements Specifications	2
2.4. House of Quality	11
3. Research.....	12
3.1. Existing Similar Products and Projects	12
3.1.1. SimpliSafe	13
3.1.2. Digital Assistants	13
3.1.3. Raspberry Pi Projects.....	13
3.2. Relevant Technologies	14
3.2.1. AC Thermostat	14
3.2.2. Household Lighting	17
3.2.3. Smart Outlet	19
3.2.4. Wireless Technologies	22
3.2.5. Web Server Technologies	23
3.2.6. Cloud Computing Services.....	24
3.2.7. Databases.....	26
3.2.8. Web Technologies	28
3.2.9. Front End Technologies	29
3.2.10. Front-End Frameworks	30
3.2.11. Infrared Sensing Technologies	32
3.2.12. Blackbody Radiation.....	36
3.2.13. Raspberry Pi 3 Model B+	38
3.2.14. Raspbian	39
3.2.15. Project Management Tools.....	39
4. Related Standards and Design Constraints	40
4.1. Related Standards.....	40
4.1.1. IEEE 802.11 Wi-Fi	40
4.1.2. Universal Serial Bus	40

4.1.3. HTTP.....	40
4.1.4. Hypertext Markup Language.....	41
4.1.5. Cascading Style Sheet.....	41
4.1.6. Coding Standards.....	41
4.1.7. ZigBee.....	42
4.1.8. JSON.....	42
4.2. Design Constraints.....	43
4.2.1. Economic and Time Constraints.....	43
4.2.2. Environmental and Social Constraints.....	43
4.2.3. Health and Safety Constraints.....	44
4.2.4. Manufacturability Constraints.....	44
4.2.5. Political Constraints.....	45
4.2.6. Ethical Constraints.....	45
4.2.7. Software Prototyping Constraints.....	45
4.2.8. Testing Constraints.....	46
5. Project Hardware and Software Design Details.....	47
5.1. Hardware Design Details.....	47
5.1.1. AC Thermostat Design.....	47
5.1.2. SMART Outlet Design.....	51
5.1.3. Light Switch Design.....	55
5.1.4. Fire Detector Housing.....	59
5.2. Software Design Details.....	63
5.2.1. Microcontroller Components Software.....	63
5.2.2. Considerations for Network Connection Between Hub and LAN.....	68
5.2.3. Networking Overview.....	70
5.2.4. Device Discovery.....	72
5.2.5. Client-Server Communication.....	75
5.2.6. Software Block Diagram.....	82
5.2.7. Auxiliary Services.....	83
5.2.8. System Security.....	83
5.2.9. Class Diagrams.....	84
5.2.10. User Interface Overview.....	85

5.2.11. Database Schema Overview	92
5.3. Optical Design Details.....	94
6. Prototype Testing.....	96
6.1. Hardware Testing	96
6.1.1. AC Thermostat Testing Plan	96
6.1.2. Light Switch Testing Plan	99
6.1.3. Smart Outlet Test Plan	101
6.2. Software Testing	103
6.2.1. Integrated Development Environments	104
6.2.2. Website Testing	104
6.3. Optics and Sensor Testing	108
6.3.1. Secondary Sensor Testing	113
7. User Manual	117
7.1. Account Management.....	117
7.1.1. User Registration	117
7.1.2. Profile Management.....	117
8. Future Improvements	117
8.1. Fire Detection Improvements	117
9. Administrative Content.....	120
9.1. Milestone Discussion	120
9.2. Division of Responsibilities.....	121
9.3. Budget Discussion.....	121
Appendices.....	123
References	123
Copyright Permissions	124

List of Figures

Figure 1. House of Quality.....	12
Figure 2. Legend for House of Quality.....	12
Figure 3. Wiring of an AC Thermostat.....	15
Figure 4. Example of Material Design for Bootstrap Component	31
Figure 5. Example of Materialize CSS Component	31
Figure 6. Example of Bootstrap Component	31
Figure 7. Working Mechanisms of PIR sensor [1].....	32
Figure 8. Transmission Spectrum of N-BK7	34
Figure 9. Transmission spectrum of Zinc Selenide	34
Figure 10. Transmission Spectrum of Calcium Fluoride.....	35
Figure 11. Transmission Spectrum of Sodium Chloride	35
Figure 12. Transmission Spectrum of Magnesium Fluoride	36
Figure 13. Blackbody Emission Spectrum of “Typical” Hydrocarbon Fire	37
Figure 14. Transmission Spectrum of the Sun.....	38
Figure 15. Example of PEP 8 Guideline.....	41
Figure 16. Correct Guideline Example – Django.....	42
Figure 17. Wrong Guideline Example – Django.....	42
Figure 18. Example of JSON object structure with nested object	43
Figure 19. Hot Work Permit for Testing.....	46
Figure 20. Smart Thermostat Schematic.....	49
Figure 21. Smart Thermostat PCB Layout Mockup.....	51
Figure 22. Smart Outlet Schematic	53
Figure 23. Smart Outlet PCB Layout Mockup.....	55
Figure 24. Smart Light Switch Schematic	57
Figure 25. Smart Switch PCB Mock Layout	59
Figure 26. Sensor Housing with Lens Holder and Baseplate	60
Figure 27. Flame Detector Schematic	62
Figure 28. Fire Detector PCB Mockup.....	63
Figure 29. Function Diagram	64
Figure 30. Software Process.....	65
Figure 31. System Class Diagram	66
Figure 32. System Diagram	66
Figure 33. Thermostat System Flowchart.....	67
Figure 34. Diagram of four-part WPA2 Handshake	68
Figure 35. Example of a typical router WPS authentication button.....	70
Figure 36. Network Diagram	71
Figure 37. Ping Scan outline, with arrows representing ICMP ECHO requests.....	72
Figure 38. Example of DNS-SD based discovery of a network service.....	73
Figure 39. Example of UDP-Broadcast	74
Figure 40. Example of Configuration Profile	75
Figure 41. Account and Hub Association Diagram	77
Figure 42. Example of POST Transaction.....	80

Figure 43. Tentative Block Diagram	82
Figure 44. Tentative Block Diagram	83
Figure 45. User UML Diagram	84
Figure 46. User and Dashboard Management.....	85
Figure 47. Login Layout Utilizing Materialize CSS	85
Figure 48. Login Layout with Material Design for Bootstrap	86
Figure 49. Login Form.....	87
Figure 50. Social Media Login.....	87
Figure 51. Registration Form	88
Figure 52. Dashboard Overview Example.....	89
Figure 53. Profile Information	89
Figure 54. Profile Editing	90
Figure 55. Example of Outlet Control.....	90
Figure 56. Registration and Login Flowchart	91
Figure 57. Password Reset Flowchart	92
Figure 58. Example of User Information in Database.....	93
Figure 59. Example of User Information Stored with MongoDB.....	93
Figure 60. Tentative Database Schema	94
Figure 61. Silicon Photodiode with Circuit Board.....	94
Figure 62. Passive Infrared Photodiode.....	95
Figure 63. Passive Infrared Photodiode.....	95
Figure 64. Test User Registration Information	105
Figure 65. Test User Information in Database	105
Figure 66. Confirmation of Test User Log In.....	106
Figure 67. First Step for Password Reset.....	106
Figure 68. Second Step for Password Reset	106
Figure 69. Third Step for Password Reset	107
Figure 70. Fourth Step for Password Reset	107
Figure 71. Fifth Step for Password Reset	107
Figure 72. Successful Login After Password Reset	108
Figure 73. Small Flame Detection AC Output Without Lens Present	109
Figure 74. Equation 1	109
Figure 75. NIR Sensor DC Response Rise/Fall Time	110
Figure 76. NIR Sensor DC Response for FOV Edge Detection	110
Figure 77. NIR Sensor AC Response at 3 Inches	111
Figure 78. NIR Sensor AC Response at 60 Inches.....	111
Figure 79. Human Noise at 12 Inches	111
Figure 80. Human Noise at 3 Inches	111
Figure 81. PIR Output for Consistent Triggering Measuring Period	112
Figure 82. AC Response to the Sun.....	113
Figure 83. AC Response to Light source.....	114
Figure 84. DC Response of NIR Sensor with Tuned Potentiometer.....	114
Figure 85. AC Output Response of NIR Sensor for Heated Quartz.....	115

Figure 86. DC Output Response of NIR Sensor for Heated Quartz.....	115
Figure 87. PIR Sensor Output Voltage with Adjusted Potentiometer.....	116
Figure 88. NIR Sensor Operating with 6V Input Voltage	116
Figure 89. Ultraviolet Photodiode for Flame Detection	118
Figure 90. Transmission Spectrum of Fused Silica.....	119
Figure 91. Lms49PD-05 Series Spectral Response of Operational Bandwidth.....	120

List of Tables

Table 1 Project Hardware Requirement Specifications.....	4
Table 2 Project Software Requirements Specifications.....	9
Table 3 Market Analysis of Wireless Thermostats	14
Table 4 Market Analysis of Wireless Light Switches	17
Table 5 Market Analysis of Wireless Controlled Outlets.....	20
Table 6 Price Comparison.....	26
Table 7 Comparison Between MySQL and MongoDB.....	28
Table 8 Raspberry Specifications.....	38
Table 9 Terminals Descriptions	48
Table 10 Bill of Materials	50
Table 11 Bill of Manufacturing.....	54
Table 12 Switch System State Machine	56
Table 13 Bill of Manufacturing.....	58
Table 14 Sensor Housing Dimensions and Positions	60
Table 15 Baseplate Dimensions and Positions.....	61
Table 16 Bill of Manufacturing.....	61
Table 17 HTTP Methods	79
Table 18 Outer JSON Fields	81
Table 19 Thermostat JSON Fields	81
Table 20 Outlet JSON Fields	81
Table 21 Sensors JSON Fields	82
Table 22 Current Database Schema	93
Table 23 AC Thermostat Hardware Component Testing Plan	96
Table 24 Light Switch Hardware Component Testing Plan	99
Table 25 Outlet Hardware Component Testing Plan	101
Table 26 Small Flame Detection.....	108
Table 27 Large Flame Detection DC Output.....	109
Table 28 Passive Infrared Photodiode Operating Specifications	112
Table 29 Milestones.....	120
Table 30 Division of Responsibilities	121
Table 31 Budget Allocation	121

1. Executive Summary

Today, most people want their day-to-day lives interactions to occur in a fast, simple and convenient manner. From driving to work without having to step on the accelerator pedal to coming home and having their bedroom lights turning on as we step into the room. The aim of this project will be to take care of this last stage. We want, that our users to not have to worry about manually turning their lights on, remembering from turning the stove off, and forgetting to change the temperature of their air conditioning system. With our Home Safety and Automation System (HSAS) it will be all integrated for easy control and management of most of the devices in a home.

The goal of the system is to provide the end-user with a one-stop interface where they will be able to control, monitor, and manage their home lights, outlets, cameras, and air conditioning system from a simple and easy to use interface, from anywhere they like. We hope to provide a home automation system that is convenient for the average user to use and requires minimal installation and maintenance.

With the popularity of many “smart home” devices, our proposal is not something new. We think of our system as an alternative to the expensive solutions on the market today. With a modular approach, this will allow for the user to select only the modules they deem necessary for their residence, therefore reducing the total cost.

Infrared motion detectors will be able to detect when someone enters or leaves a room, or if someone is at the front door. This functionality will be the core of the system, as it will help determine if the lights of a specific room should be on or off, or if the stove should be on when there is no one at home, for example. Near Infrared photodiodes will also be used to detect the temperature in a specific room. Its main purpose will be to alert the homeowner of a fire in their premise. Since this sensor permits a much faster response time than common smoke detectors, it will allow the user to react in a timely manner.

The system will also facilitate the control of outlets spread across a house. With our system acting as a middleman for the device and the power grid of the user’s electrical system, they will be able to control when a specific outlet should receive power and for how long. This will improve power usage and help reduce the overall power cost of a household.

To integrate the features described previously, the system will also provide a simple user interface that can be accessed from anywhere through a web browser where the user will be able to control and manage all the sensors and devices connected to the system. The interface, will also allow the user to monitor the power usage of the devices, therefore reducing the power cost of the system and the household.

The main objective of our project is to create a modular and simple to use Home Safety and Automation System that can be easily installed and maintained by anyone in their household. Similar projects were utilized as a start point to better decide what could work and could not. All the functionalities were extensively researched in order to be efficiently designed and implemented for the final project. Each member contributed equally on all the sections of this project, so a fully functional product could be developed and presented for faculty and other students.

2. Project Description

In the following sections, we will discuss the motivation behind our idea, the goals and objectives of our project, provide the reader with the requirement specifications, and also provide an analysis of the House of Quality diagram.

2.1. Project Motivation

Popularity of smart home systems are on the rise, but many are extremely expensive. We realized that the idea of a smart home already has many subsystems for monitoring activity, so we decided to combine an automated home system with a safety system for an all-in-one interface. It will be comparatively low-cost to other automated home systems and include security functionality such as fire detection, front-door identification, and light management.

2.2. Goals & Objectives

The main goal of this project is to make the daily life of our end-user easier. We want our users, to be able to control most of the devices in their household and to receive alerts about them in an efficient and simple manner. We also another important goal to build a low power system. In this way, we are able to provide the customer with a low-cost system and at the same time we can monitor the household power usage to further reduce energy costs.

In order to convey this information in a comfortable way, we need to develop a user interface that is friendly and not cluttered. This interface needs to be simple, but at the same time the user should be presented with all the information they need with the least number of steps. Also, it is important for the controller system to be portable, since we are giving the user the option to access it from anywhere they desire, we eliminate the need of a standalone device with the sole purpose of being used to control the system. The user will be able to do so from any internet connected device, be it a smartphone or a computer. With this feature, we are ultimately able to reduce the overall cost and provide the user with more flexibility to manage the system.

Since we have opted to a modular system, this modularity also needs to convey simplicity. We do not want our end-user to have a cumbersome installation of the system. Our objective is to make the installation as simple as possible, where a user with no electronic expertise can perform it easily.

With these goals and objectives in mind, we believe we will be able to build a product that will serve as a cheaper and more attractive alternative to similar products in the market.

2.3. Requirements Specifications

In the following section, we will give an overview and discuss the requirements specifications we set for the project. These are directly connected to the goals and objectives we have discussed in the previous section and will allow our product to be functional. These are also available on tables 1 and 2.

Motion Detectors and Infrared Photodiodes

Infrared motion detectors will be able to detect when someone enters or leaves a room. This is essential for allowing users to know if someone is in their house and can provide a speedy reaction to burglary or other crimes. These sensors will also be embedded into the doorbell to detect when someone is at the front door to allow recording of any visitors. They also act simply to communicate to the other portions of our system that someone is home to turn on lights or switch the air conditioning setting.

A fire detection system will be set in place by utilizing NIR photodiodes to detect high temperatures within a room. These photodiodes will operate at the peak blackbody emission of house fires, around 1.1 micrometers, and communicate to the central system when something in the room is emitting at this spectrum. This system has a much faster response time than smoke detectors, so the user will be able to react in a timelier manner.

The proximity of the motion sensors will be conical and limited to about ten to twenty feet, so several will be spaced in the same room. The photodiodes have a shorter proximity limited to around 2.5 feet for small flames and a much further range as the flame increase, so many more of them will be connected in a circuit for each room. This will ensure that all points of interest including heated appliances and electrical sockets are carefully monitored.

A single lens system will be implemented to increase both field of view and range of the infrared photodiodes. This will increase the input signal from any household fire and increase the reliability of the photodiode. The lens will also focus noise from incident outside sources onto the photodiode, so an anti-reflection coating will be utilized to create a better signal to noise ratio in the system. The photodiodes will be housed in an aluminum box to reflect any of the signal which wasn't completely incident on the photodiode back onto it.

Air Conditioning Control

The system will be able to turn AC units on and off with the use of a relay installed at the AC controller. If time constraints permit, the system will also be able to act as an AC controller with the addition of a temperature sensor. The user will be able to set up an AC schedule and Automatic AC through the use of the system Web Application. The user will also be able to see reports of when the AC system was on and off and which temperature it was operating at. In this way, we are able to give them with an overview of the power usage of the system and to help manage the cost.

Smart Outlets

The system will be able to incorporate Smart Outlets through either direct GPIO manipulation to a modified outlet or by using the IP accessible wireless outlets already available in the market. The user will also be able to label and turn these outlets on and off through web interface. Again, the user will be able to monitor the power usage of such outlets, giving them a better control of the power cost of their household.

Central Hub

Sensors, cameras and outlets interfaces will be connected to a microcontroller platform such as an Arduino or Raspberry Pi. In this way, the central hub can relay the information collected from the devices to the web server where the user interface will be hosted.

User Interface

Included with the system, a web interface will allow users to manage and control the system. The web interface will be the main link between the users and the system, it will be the controller for the system. It will allow the user to be able to program the system to their requirements, see data logs and reports, and manage access to the system. The web interface will also directly interact with the central hub, so it is able to receive the necessary information to display to the user.

Requirements Table

On tables 1 and 2 you'll find the detailed list of project requirements and deliverables with component constraints along with advanced features that may be modified if difficulties arise and Wish List features that will be implemented if time and budget permits. (Numbered x.y. where x = Feature Number, y = Feature Specification Number)

Table 1 Project Hardware Requirement Specifications

Spec Number	Specification Name	Specification Description	Specification Justification	Priority
Outlets				
1.0	SMART Outlet Control Switch	A standard outlet modified with wirelessly controlled a 5V relay switch	This will allow for system control of the outlet and allow for a core feature	Core
1.1	SMART Outlet Current Draw	The Outlet must allow for a max current draw of at least 15 amps.	This is standard for in home outlets as the standard home breaker circuit trips at over 15 amps, reducing the current flow will limit our application's value	Core
1.2	Smart Outlet Component Housing	The Outlet Housing must fit in a 3"x2"x2" electrical wall box	This is to conform to NEC standards and make sure the housing fits into the electrical outlet box.	Core
1.3	Smart Outlet Wiring Compatibility	The Outlet must support at least 12 AWG wire connections.	This is the NEC standard wire size for 110V 15A circuits	Core

Table 1 Continued

Spec Number	Specification Name	Specification Description	Specification Justification	Priority
Outlets				
1.4	Smart Outlet Wireless Range	The range of the SMART Outlet signal should be a spherical radius of 30M	Will expand application value by being able to use our device in larger homes	Advanced
1.5	Smart Outlet Current Sensor	The Outlet should be able to measure the amount of current being drawn	Nice to have feature for managing energy efficiency	Advanced
Light Switch				
2.0	Lighting Control Switch	A wireless module with 5V output that will control a relay switch that will allow for the control of any standard home appliance	This will allow for the control of room lighting, or any appliance that is wired to the switch. Fans, Garbage Disposal, etc.	Core
2.1	Lighting Control Switch Current Draw	The switch must support a maximum current draw of at least 15 amps	This is standard for in home outlets as the standard home breaker circuit trips at over 15 amps, reducing the current flow will limit our application's value	Core
2.2	Lighting Control Switch Housing	The Switch housing must be able to fit in a 3"x2"x2" electrical wall box	This is to conform to NEC standards and make sure the housing fits into the electrical outlet box.	Core
2.3	Lighting Control Switch Wiring Compatibility	The wiring connectors of the switch must support 12 AWG wires	This is the NEC standard wire size for 110V 15A circuits	Core
2.4	Lighting Control Switch Range	The range of the Lighting Control Switch's wireless signal should be at least 30m	The Range of the signal should be a spherical radius of 30M	Advanced

Table 1 Continued

Spec Number	Specification Name	Specification Description	Specification Justification	Priority
2.5	Lighting Control Switch Current Sensor	The Outlet should be able to measure the amount of current being drawn	Nice to have feature for managing energy efficiency	Advanced
AC Thermostat				
3.0	AC Thermostat Unit	A wireless module with a 5V output that will control a multichannel relay system that will allow for operation of an AC unit	This will allow for system control of the AC unit	Core
3.1	AC Thermostat Unit Voltages	The unit must be powered by 24Vac and produce ~24Vac at each output	Standard AC relay boards use 24V signals to operate, the system must be able to provide these voltages	Core
3.2	AC Thermostat Temperature	The unit must be able to accurately read ambient room temperature. The reading must be within 5% of actual room temperature	To provide accurate temp readings for more efficient AC operation	Core
3.3	AC Thermostat Display	The unit should be able to show temp information to the user through some display	Adds value to our product, almost all competitors have a display. Provides feedback to the user that doesn't require the UI	Advanced
3.4	AC Thermostat Housing	The unit's housing should be less than 8"x6"x1"	We should provide as sleek a profile as possible	Advanced
3.5	AC Thermostat Wiring	The unit should be compatible with 18 AWG wires at the terminals	Modern AC Units require this size wire to provide enough current to the loads. Our system should require this size wire.	Core

Table 1 Continued

Spec Number	Specification Name	Specification Description	Specification Justification	Priority
3.6	AC Thermostat Wireless Range	The range of the unit's wireless signal should be a spherical radius of 30m	Will expand application value by being able to use our device in larger homes	Advanced
Door Lock				
4.0	Door Lock Control System	A wireless door lock that can communicate and receive command from the system controller	This door lock will be part of the safety components of the system. (This Item Is Currently Tabled)	Wish List
Optical Flame Detector				
5.0	Fire Detection	Infrared photodiodes will alert any user of fire or exceedingly high temperatures	Alerts any user of potential danger	Core
5.1	Fire Detector Range and Field of View	A single lens system will focus incident rays onto the photodiode extending sensor proximity and FOV. Should have a range of 5m	Less photodiodes are necessary, and the monitored area will be larger	Advanced
5.2	Fire Detector Optical Noise Reduction	An anti-reflection coating will be applied to the lens to increase signal quality in the infrared spectrum. A band pass filter may be applied for optimal SNR.	The system will be more reliable because outside sources such as the sun will not trigger false positives as easily	Wish List
5.3	Fire Detector Housing	The housing for this unit should be no more than 4"x4"x2"	This is to provide as sleek a profile as possible so that the sensor can be installed anywhere	Advanced

Table 1 Continued

Spec Number	Specification Name	Specification Description	Specification Justification	Priority
5.4	Fire Detector Wireless Range	The range of the wireless signal should be at least 30m	Will expand application value by being able to use our device in larger homes	Advanced
Optical Flame Detector				
5.5	Fire Detector Power Supply	The unit must be powered by a 9V battery	To ease application requirements this device should be battery powered so there isn't a requirement for further wiring for installation.	Advanced
5.6	Fire Detector Low Power Mode	The unit should have a way to tell the user when the battery is low. This can be done through either a blinking LED or a timed buzzer sound	This will let users know when the battery will need to be changed	Wish List
Motion Detector				
6.0	Motion Detector	Passive infrared photodiodes will be utilized to sense the presence of any person	Provides the system with the initial input signal for user presence	Core
6.1	Motion Detector Range	The unit should have a maximum operating range of 10m	Increase application value by allowing the use of the unit in large rooms	Advanced
6.2	Motion Detector Housing	The housing for this unit should be no more than 4"x4"x2"	This is to provide as sleek a profile as possible so that the sensor can be installed anywhere	Advanced

Table 1 Continued

Spec Number	Specification Name	Specification Description	Specification Justification	Priority
Motion Detector				
6.3	Motion Detector Low Power Mode	The unit should have a way to tell the user when the battery is low. This can be done through either a blinking LED or a timed buzzer sound	This will let users know when the battery will need to be changed	Wish List
6.4	Motion Detector Power Supply	The unit must be powered by a 9V battery	To ease application requirements this device should be battery powered so there isn't a requirement for further wiring for installation	Advanced

Table 2 Project Software Requirements Specifications

Web Server				
Spec Number	Specification Name	Specification Description	Specification Justification	Priority
7.0	System Management	Users can manage system through a web page	This will allow the user to manage the system in a fast way	Core
7.1	Security	Unauthorized access should be prevented	This will allow the system to be secure	Core
7.3	Hosting	Web server will be hosted within a third-party service	This will prevent the user of the need to manage a server	Core
7.4	Capacity	The system should be able to support a minimum of 5 users and have space for growth	This will allow the system to be scalable	Core
7.4	Log	The web interface should provide a log of who/what triggered the sensors	This will allow the user to have greater control of the system	Advanced Feature

Table 2 Continued

Spec Number	Specification Name	Specification Description	Specification Justification	Priority
7.6	Camera	Facial recognition will be used as an extra security feature	For faster access to the system, a camera will be implemented	Advanced Feature
7.7	Mobile App	Users will also have the option to use a mobile app to control the system	Will serve as an extra option to manage the system	Wish List
Embedded Programming/System Controller				
8.0	Micro Controller	Raspberry Pi 3 Model B+	Low power consumption and light form factor make a micro-computer like the pi an ideal candidate for a system controller	Core
8.1	CPU	Broadcom BCM2837B0, Cortex-A53 (ARMv8) 64-bit SoC @ 1.4GHz	ARM processors are typically ideal for efficient low-power computing and should be more than adequate for all tasks required by the system.	Core
8.2	Memory	1GB LPDDR2 SDRAM	Most non-wish list features require negligible onboard memory. Most memory-demanding wish list/advanced features consist of basic web-browsing for physical UI and image-processing tasks for camera, for which 1GB memory should be adequate.	Core

Table 2 Continued

Spec Number	Specification Name	Specification Description	Specification Justification	Priority
Embedded Programming/System Controller				
8.3	Video Output	Full-Size HDMI port	HDMI output is included in the board to be used but will primarily only be used if the wish list goal of a physical user interface is pursued.	Wish List
8.4	USB	4 USB 2.0 Ports	Can be used to connect to peripherals and other close-range devices.	Core
8.5	Extended GPIO Header	General-purpose 40-pin input/output header	Useful for direct interface with hardware components and sensors.	Core
8.6	Storage	32GB MicroSD	Will store operating system and programs required for operation of the system.	Core
8.7	Wireless Networking	2.4GHz and 5GHz IEEE 802.11.b/g/n/ac wireless LAN, Bluetooth 4.2, BLE	Provides a wide range of wireless networking capabilities, Wi-Fi is necessary for project as described and Bluetooth has potential use as well.	Core

2.4. House of Quality

The House of Quality is a diagram utilized to tie together the needs of the consumers with the requirements specifications of the product being developed. The House of Quality for our project can be seen in figure 1, and the legend for it on figure 2. With this diagram, we can see how the customer needs relate with the specifications of our project.

	Power Efficiency			-	
	Modular Components				
	User Application			+	
	Safety Measures				--
<div style="text-align: center;"> Technical Specifications Customer Requirements </div>	Safety Measures		User Application	Modular Components	Power Efficiency
	Modular Control of Household Appliances	-	-	+/P	*
	Reliable System	+/P	-	-	*
	Intuitive Interface	-	+/P	-	-
	Easy of Installation	-	*	+/P	-
	Cost Efficient	+/N	-	*	+/P

Figure 1. House of Quality

Legend	Description
+	Positive Correlation
++	Strong Positive Correlation
-	Negative Correlation
--	Strong Negative Correlation

Legend	Description
+	Strong Relationship
*	Moderate Relationship
-	Weak Relationship
P	Increasing Relationship
N	Decreasing Relationship

Figure 2. Legend for House of Quality

3. Research

As group members, we first decided which characteristics and functionalities we wanted the system to have. With that in mind, we were able to brainstorm ideas on how we could achieve such objectives. Through extensive research, we came up with solutions for each module of our system, so it could be efficiently developed. In the next sections, we will discuss the products and technologies we researched and considered, and which we ultimately chose.

3.1. Existing Similar Products and Projects

The following is a discussion on which products that exist today in the market we compared our project to in order to have a better understanding on how to achieve our goals.

The idea of automating the household is not a new one. When we were considering this project, it was evident that other groups and companies had already embarked in a similar project. On the last years, devices connected to the internet are more and more common,

this is known as the Internet of Things, or IoT. One of the products we found on the market that is similar to our idea, is SimpliSafe.

3.1.1. SimpliSafe

SimpliSafe is a Boston based company that offers a wide variety of security options to keep their clients home secure. In a similar fashion to what we are proposing, they also offer their products with the idea of modularity in mind. The customer does not need to purchase a package of multiple systems that will keep their home safe. Instead, they choose only the components that they judge is necessary for their goals. While SimpliSafe goal is more aligned with security, and our project with automation, we believe this company is a good example to show that the components chosen can be implemented in different ways.

3.1.2. Digital Assistants

Digital Assistants have become more prominent in the past years. With offerings from Google, Microsoft, Apple, Amazon and other many technology companies, we think they deserve to be mentioned as automation devices. These devices can have many applications. It is not uncommon to see them being used as a way to control the lights of a room for example. Most of the time however, these assistants, are merely a middle man between the device being controlled and who is controlling such device. For our project, we are aiming to eliminate this step, to reduce the cost of implementing such system. We believe that this will allow the control of such systems to occur more fluidly and it also will consolidate the number of different controllers into a single system.

3.1.3. Raspberry Pi Projects

Many companies have opted for automated room units to conserve electricity for both economic and environmental reasons. One example specifically resembles our project with its usage of both a Raspberry Pi module as a central hub component and passive infrared sensors for motion detection which was published in 2018. The goal of the observed project is to connect home appliances in a communication network with one another using the internet. The Raspberry Pi module was selected for both its functionalities and low cost of about \$25-30 [1]. An operating system is necessary for the Raspberry Pi to perform essential functions, and all operating systems available for it utilize Linux. The specific operating system used by the study is called Raspbian, and it was chosen because it is the officially supported operating system by the Raspberry Pi Foundation [1].

The Raspberry Pi has many different specifications which make it optimal for this type of project. The presence of a Micro USB power port, which can give an input current of 2 amps, allows for an easy power source for the system. The 40 pin GPO header allows for many inputs and outputs to communicate with both the PIR sensors and the light and AC controls. The 10/100Mbps ethernet ports allow for internet connectivity to allow users to control the system remotely. The MicroSD card slot lets users have variable input memory for scaling of simple to complex systems based on the size of the automation system. The Raspberry Pi has ample processing speed for this application with its 700MHz processor. Ease of installation is also a large reason that the Raspberry Pi was chosen for this project.

3.2. Relevant Technologies

The following is a discussion on the technologies already available in the market, the products that were considered, and the reasoning on why they were ultimately chosen to be used in our project.

3.2.1. AC Thermostat

The Goal

The HVAC system in a home is probably the most impactful in terms of the Home's energy efficiency and comfort. Maintaining strict user control of this system is crucial for the Home Automation experience. With our product, users will be able set a target temperature, create a system schedule, and operate the system from any number of mobile devices. This is not the first smart thermostat, there are many of these devices already in the market, our goal is to make these devices cheaper and more accessible. The following table illustrates some the highest rated Thermostats under \$200, their features, and retail prices.

Table 3 Market Analysis of Wireless Thermostats

Market Analysis				
Product Name	Feature 1	Feature 2	Feature 3	Price
Emerson Sensing ST55	Flexible Scheduling	Geofencing	Proprietary App	\$129.99
Honeywell Programable Wi-Fi Thermostat RTH6580WF	Flexible Scheduling	Local Weather, System Alerts	Proprietary App	\$79.99
Nest Learning Thermostat T3007ES	Auto Scheduling	Adjusts for Local Weather Changes	Proprietary App	\$189.99
Our Product	Flexible Scheduling	System Alerts	Web Application	Target Price \$50

The Wiring

The typical control wiring for a conventional central air conditioning system includes a thermostat, a condenser, and an air handler with a heat source. The Thermostat typically consists of 5 terminals. One is the 24v hot feed from the control step down transformer that will power the relay or complete the AC circuit board. This is typically a Red wire. The White terminal provides power for the heating element of the AC unit. The Green terminal powers the blower fan in the air handler. The Yellow terminal is usually the control. This is the terminal we would need to take over from the thermostat to turn the AC on and off. The Black Terminal is the common ground. To achieve the level of control we would like with our AC system controller we will need a few items in our circuit. We will need an AC-DC Power Supply Module that goes from 120v to 24v to power the relays and a stepdown voltage generator to go from 24v to 3.3-5v to power the wireless MCU.

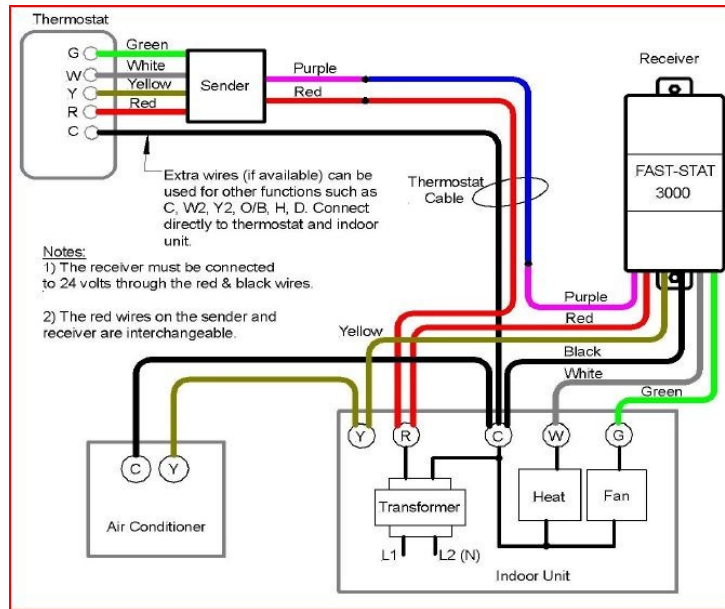

Figure 3. Wiring of an AC Thermostat

The Power Supply

There are hundreds of power supply modules that can work for this system in the market, but we will only consider the most inexpensive power supplies available through reliable online retailers. The first candidate is the DAOKI AC-DC Power Supply Module AC 85-265V to DC 24V 6A Switching Power Supply Board Model XK-2412-24. This module is readily available, has overvoltage protection, takes in AC 85-265V at 50 or 60Hz and outputs 24V at 4-6A. It's rated output power is 100W which is more than enough to power our system and price is a little less than \$10.

The next candidate for our Power Supply module is the TOFKE AC - DC Power Supply Module DC 24V 4A/3.3V 1A Dual Output AC 90-265V to 24V 3.3V 120W Industrial Power Module Isolated Power Transformer. This module provides a lot of the same specs as the previous Daoki but with the added benefit of dual output. By using the 3.3V output from this power supply, we will no longer need a stepdown voltage converter, this of course is reliant on the MCU only needing 3.3V power. Due to the extra feature this module is a little pricier at \$13.

The Stepdown Voltage Regulator

One possible module that will work when using a single 24V output Power Supply is this DZS Elec 2PCS LM2596 DC-DC Step Down Variable Volt Regulator Input 3.2V-40V Output 1.25V-35V Adjustable Buck Converter Electronic Voltage Stabilizer Power Supply Module. This covereter is 92% efficient, has an output ripple of less than 30 mV, compact with dimensions of 4.3x2.1x.1.4cm, and operates at temperatures up to 85C. The best thing about this regulator is its adjustability. By turning the potentiometer one can output whatever voltage desired from 3.3V to 35V. Two converters cost about \$7.

Another option is the Wolfwhoop PW-D Control Buck Converter 6-24V to 5V 1.5A Step-Down Regulator Module Power Inverter Volt Stabilizer. This Buck Converter is tiny, the

board is 1.7x5.5cm and the price is reasonable, 4 for \$10, however the output is not adjustable which means this will only work for an MCU that takes 5V as its input.

The Wireless Microcontroller Unit

The ESP8266 ESP-12E WiFi Microcontroller USB Development Board is a very popular, reliable wireless module. The ESP8266 is a low-cost Wi-Fi chip with full TCP/IP stack and MCU. The ESP-12E module is a shielded breakout board that combines the ESP8266 with 4MB of flash and a PCB antenna. This development board integrates the ESP-12E module with a CH340G USB TTL adapter chip, power converter circuitry, buttons, and breadboard compatible pin header. The default firmware can add WIFI capability to another microcontroller over a serial interface. The module comes in around \$5. There is plenty of support for integrating the ESP8266 into all kinds of systems, but this model is missing some key features like a relay system to turn the 24V terminals on/off. Choosing this board would mean we would need to design those relays ourselves.

Then comes the LinkSprite 211201004 Link Node R4 Arduino-Compatible Wi-Fi Relay Controller. This module is powered by the same ESP8266 above but with the added benefit of 4 controllable relays. This will allow us to wirelessly control the 4 needed terminals for the AC controller. The module will be pricey, at a cost of \$12 but it should reduce design time and prototype difficulty because we will not need design the relay system ourselves. This system is powered by a 5V input with 1A max draw.

The Temperature Sensor

To know when to power the AC and for feedback so that users know the room temperature and for automatic setting we will need a compatible temperature sensor. A cheap and easily available option is the DHT11. This is the NOYITO DHT11 Digital Temperature Humidity Sensor Module. There are many manufactures of this device but this is one available in amazon. It is powered by a 5V input with .3mA draw and has a digital output that communicates using I2C. This device measure relative humidity from 20-90% with a standard deviation of 5% and temperature measurements from 0-50C with a deviation of 2C. This sensor is usually priced around \$3 each. Our other option is the DHT22. This is a more accurate sensor compared to the DHT11, but with better accuracy comes a higher price. It is made by many manufacturers and costs around \$6.

The Verdict

For this AC Controller Unit component we will be using the DAOKI AC-DC Power Supply to power the system, the Wolfwhoop PW-D Control Buck Converter to power the LinkSprite Wi-Fi Relay Controller and the DHT22 temperature sensor. These components provide the best combination in terms of price and compatibility and should be enough to meet the requirements of our AC control unit. We went with the DHT22 because to provide better energy efficiency our system needs to be as accurate as possible with sensor readings. The Wolfwhoop should be sufficient to power the MCU and the sensor. Budget for the hardware costs will need to be around \$30.

3.2.2. Household Lighting

The Goal

Controlled lighting is a key feature necessary to produce optimum energy efficiency inside a home. We want a system that can automatically manage the user's lighting needs by using the array of sensors we provide to reduce waste in the system. The lights should only be on when needed. To provide these energy saving features, without taking complete control from the user we will integrate wireless light switches into the system. With our product, users will be able to schedule the auto light feature, turn on/off room lights manually, and operate the system from any number of mobile devices. This is not the first smart switch, there are many of these devices already in the market, our goal is to make these devices cheaper and more accessible. The following table illustrates some the highest rated smart switches under \$40, their features, and retail prices.

Table 4 Market Analysis of Wireless Light Switches

Market Analysis				
Product Name	Feature 1	Feature 2	Feature 2	Price
TreatLife WiFi Smart Switch	Flexible Schedule, Timer	Proprietary App	Alexa, Google Assistant Compatible	\$19.99
Kasa Smart Light HS200	Flexible Schedule, Timer	Proprietary App	Alexa, Google Assistant Compatible	\$39.99
Eoce Smart Light Switch	Flexible Schedule, Timer	Proprietary App	Alexa, Google Assistant Compatible	\$16.45
Our Smart Light Switch	Flexible Schedule, Timer	Web Application	Auto Motion Sensing On/Off	Target Price \$15

The Wiring

Household electronics, switches and outlets have to follow strict codes and guidelines that require certain design standards and safety measures to be present. These codes can differ state to state and even change depending on the municipality the building is in. We will be following the National Electrical Code (NEC) set by the National Fire Protection Association (NFPA). The NEC sets the foundation for electrical safety in residential, commercial, and industrial occupancies. The latest edition of this trusted Code presents the latest comprehensive regulations for electrical wiring, overcurrent protection, grounding, and installation of equipment. (NFPA.ORG) These standards have been adopted in all 50 states and for any design or component that we will use for this project, strict adherence to these measures should be followed. To make things easier we will not try to reinvent the wheel by designing our own light switch. To design a wireless device that will allow us to automate room lighting we will use a standard 3-way home light switch like the model 5603-2W from Levinton and add a controllable relay switch and programmable wireless MCU like the ESP8266 to send signals from the server application to the device. The relay and the light switch will be wired in a three-way configuration. This will provide the best usability for our product. This will mean that both the light switch and relay will work as

a toggle independent of the other. To achieve this creation, we will need a few components in the device:

- Power Supply capable of taking 120V AC to 3.3V to 5V DC depending on the MCU-Relay module used
- Wireless MCU that can communicate through an in home WIFI network and takes TCP/HTTP commands
- Relay system that is triggered by a 3.3-5V signal with at least 2 channels switching and capable of supporting 10 amps or more
- A current sensor to measure when the light is on.

The MCU and Relay System

In researching the AC System Controller, we decided to go with the ESP8266 MCU. We will stick with using the ESP8266 with most of our wireless components and sensors. Unlike the AC Controller we will not be needing a four-channel relay array, so we can use something like ESP-01S WIFI relay module. This module comes with a relay with two switching nodes. This is perfect for our application because we can use this to toggle the light switch or open the circuit and ensure the light switch stays off. This board requires 5-volt power supply and uses about 1W which means we should aim for a power supply that can produce 5V with anything greater than 1A.

Power Supply

One possibility for the power supply comes from the brand Hi-Link. The HLK-PM line of power modules meets UL and CE (Conformité Européenne) requirements, takes in all standard voltage inputs (AC: 90 ~ 264V), has low ripple and low noise, output overload and short circuit protection, High efficiency, and high-power density. This product is designed to meet the requirements of EMC (Electromagnetic Compatibility standards) and Safety Test. It also has low power consumption, environmental protection, no-load loss <0.1W. (Hi-Link) Which really just means we can trust the dependability of this device to do what it says it will do and safely. The HLK-PM comes in 3 configurations: 3.3V, 5V, and 12V outputs and can be purchased for around \$3-7.

Another candidate is the ESHION AC-DC 5V 1A Switching Power Supply Board. This board is a little more exposed but can be used solderless as it has AC input pins and DC output pins. It provides similar safety measures and standards as the Hi-Link module but can support up to 1A. The Hi-Link can only support a max of .6A. This module cost 5-7\$. The ESHION measures 3.8X1.8X1.6cm which is comparable to the HLK-PM01 at 3.4 x 2 x 1.5cm so we are not gaining much in volume.

Current Sensor

Due to the three-way circuit between the paddle switch and the relay module, there is no way to know if the light is on or off by observing the position of the relay switch. For user feedback and so that we can display when the room light is on we will need a current sensor to measure the load. One possible solution is to integrate the ACS712 sensor. This sensor Outputs 100mA/V so not only does it measure whether there is current passing through

or not it also measures the amount of current. The sensor is available to support max currents of 5A, 20A, and 30A. Since the relay system we are using will have a 10A limit we will look at sensors that support 10A or more. This sensor has a total output error 1.5% at $T_A = 25^\circ\text{C}$, Internal conductor resistance $1.2\text{ m}\Omega$, powered by 5V, and works at Temperatures 40°C to 85°C , with an analog signal output. The cost of this sensor can range from 2-\$10. Many of the other sensors available are either variants of this model but made by other manufacturers, or too expensive, for amp ranges we don't need to consider, or too bulky, using magnets around the cable to test for current indirectly.

The Verdict

Due to price and availability the best candidate for the power supply will have to be the HLK-PM01 from Hi-Link. Most smart switches in the market are available for around \$15 which means we need to keep our HW available at or below market value to be competitive. Using a Power supply that costs a third of our target retail price is not very feasible however if after testing it is determined that more than .6A is needed to power all the 5V components then we will have to consider switching to the more expensive PSU. The MCU/Relay board estimated at \$3, the PSU at \$3, the current sensor at \$2, and the light switch estimated to be around \$4 will make this device cost around \$12. Granted it will be difficult to make a profit when the hardware costs almost as much as our target selling price, but these numbers are retail acquisitions. If we can come under our desired budget with retail priced components than we should be able to drastically reduce our costs when we order directly from the manufacturer should we decide to produce these items.

3.2.3. Smart Outlet

Our Goal

Wirelessly controlled wall outlets are another essential component necessary to have a truly automated experience at home. These outlets are readily available in the market but at costs ranging for \$25-\$40. There are smart plugs available for around \$10, but we want a seamless experience. Our products should be as inconspicuous as possible and look like ordinary standard home equipment as to not detract from a user's personal home style. We think we can make this device a lot cheaper than the ones available at online retailers today. The design will be simple, we will connect a controllable relay to the hot line of a standard home outlet and close or open the circuit as desired. To build our SMART outlet we will need a standard NEC (National Electrical Code) compliant wall outlet. We will also need a wireless relay module similar to ones used for some of our other components like the esp8266. Lastly, we will need a power supply unit to power the relay module. Table 5 displays our analysis of competing devices and we will demonstrate how we can undercut the competition in price without losing key features.

Table 5 Market Analysis of Wireless Controlled Outlets

Market Analysis					
Product Name	Feature 1	Feature 2	Feature 2	Current Draw	Retail Price
Topgreener Smart Wi-Fi Receptacle	Flexible Schedule, Timer	Proprietary App	Energy Monitoring	15A	\$39.99
Kasa Smart Wi-Fi Outlet	Flexible Schedule, Timer, Away Mode	Proprietary App	Alexa, Google Assistant Compatible	15A	\$39.99
MOES Wi-Fi Wall Outlet	Flexible Schedule, Timer	Proprietary App	Alexa, Google Assistant Compatible	15A	\$16.45
Our Smart Power Outlet	Flexible Schedule, Timer	Web Application	Energy Monitoring	15A	Target Price \$20

The Wiring

Basic home outlet wiring depends on 3 wires, a Hot wire that provides power and is usually black, a Neutral wire that is the return feed for any electricity not used and is usually a white or gray wire, and a brown or green ground wire that is needed in the case that a hot wire has come in contact with some metal component of the object being powered. This is a safety measure to reduce the risk of shock in case of a short circuit. So to build this component we will need the relay to be able to open the Hot wire so that any failure in the system will ensure no power goes to the outlet. The standard home outlet is connected to a 15A breaker system, which means our relay must be able to perform at 15A. Getting a relay that supports less power will severely limit the capabilities of the outlet. A relay that supports more power would be overkill because any load that would draw more than 15 amps would trigger the breaker switch. Therefore, some of the previous relay modules we have studied will not work for this part of the project.

The Relay Module and MCU

Taking an ESP8266 and a 15A 5V relay and creating our own circuit design is a possibility, however this would put far too much of a design and compliance burden on our team, so we will try our best to stick with readymade components that will only require programming and integration. This is very important to maintain the highest safety standards when dealing with high voltage and current. So far, the only ESP8266 relay module that we have found to support up to 15A at 120V is this one from Olimex. Unfortunately, the desire to use prebuilt modules for our project will mean we will have to pay top dollar for some components. This board will cost about \$16 shipped, add in a PSU and our total hardware cost is hovering around \$21, which is still under the retail price of the competition, but we will have minimal profit margins unless we manage to reduce the

price of a prebuilt module like this one. In the Olimex's defense, it is a great little piece of technology and has some key desirable features. This includes:

- Relay 10A/250VAC (15A/120VAC 15A/24VDC) with connector and status LED
- Big button for easier access to UART mode
- Power jack for +5V external power supply
- UEXT connector
- Row of 16 pin holes at 0.1" step with all ESP8266 signals accessible; male-male 16-pin connector included
- 4 mounting holes

Not to mention the ESP8266EX features like:

- 2MB SPI flash memory
- Power LED
- User-programmable LED
- SMT jumpers for different boot modes (FLASH, UART, SDO)
- PCB antenna
- UEXT pads for easier access to UART interface
- Pads for a U.FL antenna connector (for external antenna)
- 22 pin holes for easier access to processor pins
- OSHW design (Open Source Hardware Association)

All of this comes in a very compact package measuring 5.7x5x2cm and should fit easily behind the outlet. Everything considered, this board may be worth the price and if costs end up being too high, another possibility is to take one of the cheaper ESP8266 relay board and upgrading the relay on it, this will undoubtedly result in a less reliable device, and may result in safety standards not being followed.

Power Supply

We will try to use the same power supply for each component of our project so that we are able to make orders in bulk. For this reason, we will use the HLK-PM01 from Hi-Link that was researched in the Smart Lighting section of this document. As said before, The HLK-PM line of power modules meets UL and CE (Conformité Européenne) requirements, takes in all standard voltage inputs (AC: 90 - 264V), has low ripple and low noise, output overload and short circuit protection, High efficiency, and high-power density. This product is designed to meet the requirements of EMC (Electromagnetic Compatibility standards) and Safety Test. It also has low power consumption, environmental protection, no-load loss <0.1W. (Hi-Link). The HLK-PM01 is the model that outputs 5V and costs around \$3 each. Since the ESP8266EX operates at an average of 80mA we are pretty confident that the 600mA the PSU can supply should be enough for our application.

The Verdict

This pretty much sums up the major components we'll require for our version of the SMART Outlet. Total price for the HW is around \$21, however this price is not a good representation of what the actual cost of making a device such as this should be. Consider that we will be using the Olimex ESP8266-EVB, an evaluation board meant for testing and

prototyping, not to be placed in a final product. If we can have a manufacture make boards like the ESP-01S WIFI relay module, researched in the Home Lighting section, with an upgraded 15A relay at a cost of around \$3/board than you're looking at a device that costs less than \$10 to produce and can easily retail for \$20, undercutting the competition by at least a 25% discount.

3.2.4. Wireless Technologies

3.2.4.1. Wi-Fi

Due to the large number of devices generally associated with putting together a home-automation system, the prospect of achieving communication between said devices via wired networking schemes such as Ethernet has the potential to become cumbersome and expensive. To that end, the numerous wireless networking protocols available on the market today serve as an apt solution to this problem. In particular, the viability of standard Wi-Fi and the ZigBee wireless networking protocol were examined in-detail for use in this project.

Wi-Fi is a familiar and ubiquitous networking protocol that is already deployed in most homes, businesses, and other organizations which maintain a local-area-network with Internet connectivity. Wi-Fi is versatile and offers bandwidth suitable for most personal computer networking tasks. However, since Wi-Fi was never designed with low-power use cases in mind, it is not particularly suited for any applications where the networked sensor or component is expected to operate on battery-power for extended periods of time, and even if the issue of battery life is avoided by using wall-outlet power, numerous non-battery-operated Wi-Fi enabled components have the potential to significantly decrease the energy efficiency of the system as a whole. Power consumption will vary depending on the design of the device in question and the usage-characteristics of said device, but generally can be expected to vary from 4mW to 324mW, with the most inefficient use-cases being those which require the device be 'woken up' from a low-power state for frequent, short transmissions(Energy Consumption Analysis for Bluetooth, Wi-Fi and Cellular Networks, Rahul Balani).

Due to the fact that the home's control systems are to be designed so that they are accessible even while the user is away from the home, some type of Internet connectivity is necessary. In such a case, only the system's hub would need Internet connectivity, which could very well be achieved via wired Ethernet. However, if wired connections are not an option, Wi-Fi is the only wireless solution which allows for connection to an Internet-facing LAN and, conveniently, the Raspberry Pi which is to serve as the hub for the system does possess onboard wireless networking hardware which is compatible with Wi-Fi standards.

3.2.4.2. ZigBee

ZigBee is another technology of primary interest for use in in-home communication between sensors and devices which are part of the system. The primary advantages of ZigBee stem from significantly lower power-consumption as compared to Wi-Fi, the fact that devices connected on a ZigBee network are not exposed to the Internet through a LAN (reducing the chance of individual elements in the system being compromised by a third party via the internet), and from the number of off-the-shelf home automation devices which are compatible by default with the protocol. The primary drawback of ZigBee as

compared to Wi-Fi can be found in much lower data-transfer rates as compared to a more high-volume oriented technology such as Wi-Fi, but for a use case in home-automation, where communications between devices will typically be measured in bytes, the reduced bandwidth is of little concern. Another drawback of ZigBee is that specialized radio hardware is required to receive the majority of the advertised gains in power efficiency and in most cases ZigBee hardware is somewhat more expensive than comparable standalone Wi-Fi networking modules.

Given the lower cost of standalone Wi-Fi modules (approximately a dollar each, vs. three dollars or more for an equivalent ZigBee hardware solution) and the familiarity of the protocol involved, we have opted to use Wi-Fi as the primary protocol for all of our wireless networking, with the caveat that an implementation via ZigBee would certainly be possible and would likely result in an improved power-consumption profile for the system at large.

3.2.4.3. WPA Supplicant

WPA_Supplicant is a cross-platform supplicant with support for most Wi-Fi technologies including WPA2 and which can be configured to allow for direct peer-to-peer Wi-Fi access. WPA_Supplicant is available on an overwhelmingly wide variety of Linux and Unix-based systems, and even offers windows support. WPA_Supplicant oftentimes comes pre-installed on Unix based systems which can be expected to be carrying out wireless networking tasks, as is the case for most distros designed to run on the pi. Configuration can be carried out either via command-line configuration files or via graphical user interface front-ends. The degree of configurability presented by WPA_Supplicant, coupled with the detailed and extensive documentation and user-created examples available makes it an ideal choice for managing wireless connections on the hub device.

3.2.5. Web Server Technologies

In order to allow the user to have full control of the system installed in their household a controlling unit is necessary. As we discussed before, we chose to use a web interface as the controller for our system. Therefore, a web server is a fundamental requirement for that to be implemented. Two web server technologies were discussed and compared against each other.

3.2.5.1. Apache

Apache is an open-source web server software that was released on 1995 by Robert McCool. It has a Unix base and according to W3Techs is used by 44.4% of all the websites known in the Wide World Web [6]. Apache is the software of choice of the most common stack chosen for creation of websites. Such stack is called LAMP, which stands for Linux, Apache, MySQL, and PHP. These technologies are usually leveraged together when building most types of web applications for any purpose, with the main benefit of all being open-source software.

3.2.5.2. NGINX

As an alternative to Apache, the NGINX technology was also considered. It was developed after Apache in 2004 by Igor Sysoev. It is just as widely used with a 41.2% share of the

known websites, according to W3Techs [7]. When comparing to Apache, it serves dynamic content in a more efficient manner and can handle high-traffic better.

For the purpose of our project, high-traffic and dynamic content is not the case, and therefore, we chose to use Apache. Also, since the project will be hosted in a shared web server, more specifically a cloud server, rather than a dedicated one, Apache offers better security functionalities in this regard.

3.2.6. Cloud Computing Services

It is very common to outsource the work of web servers today. Most services today are hosted in the cloud. Of course, we know that nonetheless these are still physical servers. However, different from using your own server for a project, when using a server provided by a “cloud company”, such companies most of the time uses what is called the pay-as-you-go approach. The user, will only pay for the resources that were used, as opposed to paying a fixed amount no matter if they used only 5% percent of the resources allocated to them or they used 100% of the resources allocated. Since, we aim to reduce our costs, and our end-user costs as well, we chose this approach to host our controller system. In the following sections, we will talk about the most companies that offer such service, and which one we chose and why.

3.2.6.1. Amazon Web Services

Perhaps one of the most famous companies to offer such service, Amazon Web Services (AWS) is the provider of choice for many companies, from car manufacturers, to streaming companies, to startups. AWS offers a wide variety of solutions, and within those many different modules to different kind of tasks. For our project, we would mainly use their most “basic” solutions. Those would be: Elastic Compute Cloud (EC2) to host our server, S3 to host the static files and perhaps some code for the system, DynamoDB would serve as the database for the project, and finally we could even implement Lambda to run some of the code. After some researching, we came to the conclusion that condensing all of our backend programming on AWS would be the ideal, since everything is in one ecosystem. However, because of the pricing to use all of these services, we decide not to utilize AWS and chose another cloud provider. It is important to note, that we will still utilize S3, since for this service we will have no charge. AWS is one of our top candidates to be used in the project.

3.2.6.2. Heroku

Heroku is another example of a Platform as a Service (SaaS) solution. In contrast to AWS, however, it offers too few services and therefore we deemed it not to be enough for our project. Their main offer is similar to AWS Lambda, however since it would not be practical to utilize this service solely for this feature, we decided not to go forward with this option. Even though this would be a free of charge path because of their free tier package.

3.2.6.3. Netlify

Netlify is a similar solution to Heroku, however with more variety. This is also one of our top candidates, because it would allow us to run certain modules of our code on this platform in a fast and efficient manner. For example, we could implement user

authentication utilizing Netlify. However, the same problem as AWS arises again, pricing. The free tier of Netlify would not allow great scalability, but because our system is not intended to be commercialized after completed, we are still considering using this service for some parts of our project.

3.2.6.4. Microsoft Azure

Microsoft is another company to offer solutions that we could use to host our project. Similar to AWS, they also offer a wide variety of services. We could use their virtual machines, storage, and SQL database solutions. However, since as a group we do not have much experience with Microsoft solutions, we chose not to go forward with this option and choose from another company that we are most comfortable to work with.

3.2.6.5. Google Cloud

Google is yet another company to provide cloud solutions for our needs. The attractive points for them is that they offer exactly what we might need for our project. We can utilize their virtual machines, storage, and database, more specifically Postgres (which was the database of our choice), all in one place. Because of that, Google Cloud is our top candidate to host our code.

3.2.6.6. Digital Ocean

Lastly, we have considered using Digital Ocean (DO) services for our project. Given our familiarity with their system, this is also a top candidate. The benefit of using Digital Ocean, is that it would allow us for great customization and flexibility for the services we choose to run, and they also have the most competitive rates of the top candidates. Digital Ocean allows an immense amount of flexibility at a low cost. Utilizing this provider, we as a group will be able to implement many features server side which will allow us to test different functionalities for our project. For example, utilizing DO, we will be able to test different database systems to better understand which one will serve us better with little configuration, as DO provides the virtual machine owner to easily deploy the different technologies in a small amount of time. Furthermore, we can take advantage of a snapshot feature, which allows the developer the save the state of a machine, therefore it is easy to roll back to an earlier version if bugs happen to occur when testing new features.

3.2.6.7. Final Considerations and Selection

After researching the many cloud providers for our project and as discussed previously, we have now three final candidates: AWS, Google Cloud, and Digital Ocean. We have come to the conclusion that we will use both Digital Ocean and AWS solutions. The reason for that is because we will have a lot of flexibility hosting a virtual machine with DO, and given our experience with both companies, we will also be able to easily integrate it with AWS solutions, such as Amazon S3. In Table 6 we can see a comparison between the prices of packages provided by each provider discussed, if we were to use all of their services for our project.

Table 6 Price Comparison

Provider	Cost/Month (\$)
Digital Ocean	5
Amazon Web Services	15
Microsoft Azure	155
Google Cloud	25
Heroku	Free
Netlify	Free

As we can see, the most cost beneficial option is Digital Ocean, which is our provider of choice. It is also worth noting, that even though some of these providers have a total cost of zero, we have not chosen them simply because their free services are not suitable for our purpose.

3.2.7. Databases

Databases are a crucial backbone of our system. Our project will be heavily dependent on a swift and prompt operation of a good database. Because we want to be able to have many users a database is essential to be able to control such users. With this functionality, it will also act as a basic line of defense for any possible intrusions. Also, our system will have a option to monitor its power usage, given the ability for the owner to have a better understanding of how they power is being used, therefore, this date will also be stored on the database. We will now discuss the different technologies we can utilize to implement a database, be it a Structured Query Language (SQL) or a more recent option, one that is considered to be a NoSQL database.

3.2.7.1. MySQL

Perhaps one of the most known and established relational database system is MySQL by Oracle Corporation. It was initially release in 1995 by MySQL AB, and to this day is still widely used in many applications throughout the web. Because MySQL has a vast documentation and we as group have the most experience with this system, it is on the top of our list when it comes to the choice of which database to use. We believe that it will attend all of our needs and we are able to easily set up and manage such database. The only drawback of utilizing this option, is its integration with our backend system, mainly with Django. We have observed that its integration is not the smoothest one, and because of that, extra steps need to be taken in order for them both to work properly. With that being said however, this will not deter us from choosing this database system.

3.2.7.2. MariaDB

MariaDB is also a very well-known database system, which in fact is a fork of the popular MySQL. It was created in 2009 right after the acquisition of MySQL by Oracle Corporation. As such, it is very similar to its parent with the same functionalities and some advanced features to attend recent demands in the market. Because we already have experience with MySQL and we have the means to set it up properly, we see no need to migrate to MariaDB.

3.2.7.3. PostgreSQL

As an alternative to MySQL, we have the option to use PostgreSQL, which although it was released about the same time as the latter, in 1996 by PostgreSQL Global Development Group, it has recently seen a growth in its use through the more recent web applications. We have considered using this system because we know about its easier integration with Django, our web framework of choice. Therefore, this is also our top for the database system. PostgreSQL has seen a boom in its use in the recent years because of its advanced features and its reliability when it comes to large volumes of data. Precisely because of that, we have decided that our project does not need to have such system since we will not be dealing with a large amount of data. Therefore, we have chosen MySQL as our database system of choice.

3.2.7.4. MongoDB

We have previously discussed about relational database management system (RDBMS) in the previous sections and noted our selection of which one we will be using throughout the project to attend our needs. As mentioned before, apart from relational databases, such as MySQL, another classification of database systems are NoSQL systems. A very popular NoSQL database system is MongoDB by MongoDB Inc., developed in 2009. As its classification implies, MongoDB is a document-oriented database, as opposed to a table-based system. Also, MongoDB allows the developer to have more freedom in organizing their data, as no previous structural knowledge is needed. MongoDB usually works best when used with other technologies for the back-end and front-end development, such as Node.js and Angular.js, for example. However, that is not to say we cannot use it for our purposes. In fact, it turns out that MongoDB integrates very easily with our back-end framework Django. It is just as simple as changing about five lines of code and it can be used in a similar way as MySQL. For this reason, we have MongoDB as a second alternative to our main database. Another advantage of possibly using MongoDB would be that in doing so, we as developers do not need to host the database in our server. With Mongo, we can offer a free service offered by them where they host the database for us. A benefit of using this feature, would be an enhanced security for the data stored and also it would decrease the load in our server.

3.2.7.5. DynamoDB

Another option available for NoSQL databases is DynamoDB created by Amazon, and the database used in Amazon Web Services. As we have mentioned before, ideally this would be our database of choice if we were to choose the Amazon ecosystem to host our server and other functionalities for our project. However, consolidating all of our services under this umbrella would only increase our cost, which is not attractive for us. Therefore, we have decided not to go forward with this option.

3.2.7.6. Final Considerations and Selection

With our previous research and discussion shown in the previous sections, we have come to two final candidates: MySQL and MongoDB. Both are great selections for our project and would serve our users in a more than capable way. As shown, a drawback of using MySQL is its not so smooth integration with Django as the versions do not work too well together. However, that is a very small obstacle and we would classify it as more of a

nuisance than a problem. This becomes more prominent only when more than two developers are working at the same project when using different host environments. If this situation becomes the norm for our development environment, we then can consider the migration for MongoDB. As observed before, this migration would be as simple as changing a few lines of codes. Also, the load on our server would be reduced which could improve the data handling for the various other features we will implement. With these considerations in mind, we have opted to use MySQL for now. If any problems arise, we will do the migration over to MongoDB.

Table 7 Comparison Between MySQL and MongoDB

Feature	MySQL	MongoDB
Easy Integration	✗	✓
Organization	Tie	Tie
Documentation	✓	✓
Support	✓	✓
Load Handling	✗	✓

3.2.8. Web Technologies

Web development is a big portion of our project as we intend to provide the user with a web application where they will be able to manage and control their system. As such, careful consideration was taken when deciding which web technologies would be implemented and how they were going to be used to better serve the end-user. In the following section we will compare some of the most popular programming languages and frameworks used for web development.

3.2.8.1. PHP

A fundamental programming language used in web development is Hypertext Preprocessor (PHP). It was released in 1995 and is still widely used to this day. As our web application will have a strong connection to our database of choice, it is imperative to use a technology that will allow us to manipulate such data. PHP would be essential for the functioning of our project if we were to build a barebone web application, without the use of web frameworks, as we have decided to do so, and will discuss in sections ahead. Nonetheless, it is worth mentioning that PHP would be very important to allow us to implement our project.

3.2.8.2. Python

Naturally, since PHP will not be the backend language for our application, we need an alternative. Such alternative is Python. Python was first released in 1990 by Guido van Rossum and is widely used today for a number of different applications. As a group, we have a lot of experience in using Python for programming projects and because of that we have all agreed it would be beneficial for us to utilize such language. Also, since we have decided to use a web framework to aid in the development of our web application which uses Python as their base language, it only further enforced our decision.

3.2.8.3. Django

Django is a web framework which allows rapid deployment of web applications that uses Python as their base language. As we have discussed before, we have a lot of experience

in utilizing Python as a programming language. Also, because of time constraints and to allow faster and uniform testing of our application we have decided to use such framework. With our experience, we believe this will greatly benefit us to be able to implement the different functionalities we have decided for this project. Also because of the many tools available for Django and its seamless integration with the other technologies we are using for our system it will make our development process occur more fluently.

3.2.8.4. Flask

Flask, similar to Django, is also a popular web framework. However, its main difference is that is not as “well-packed” as Django. Meaning that to achieve what we can with Django, many extra steps would need to be taken, and therefore the development process would become cumbersome and more time consuming. Because Django allows us to test many functionalities in a smaller time frame, we have decided not to choose Flask as our web framework.

3.2.9. Front End Technologies

All web applications function on the basic mixture of Hypertext Markup Language (HTML), Cascading Style Sheet (CSS), and JavaScript. In the following sections, we will discuss how do we plan to integrate these technologies in our project and why they have extreme in importance in helping us achieve our goals and how they will also work in unison with the front-end framework of choice, which will be discussed in the section following this one – Section 3.2.7.

3.2.9.1. Hypertext Markup Language

Hypertext Markup Language, or HTML, is a fundamental piece of a website. Everything that is displayed to a user in a web application has its roots in a HTML element. Most often, HTML is also accompanied by other technologies such as CSS, which allows the web developer to control certain visual aspects of HTML elements and also JavaScript, which allows the developer to integrate interactive elements to the web application.

3.2.9.2. Cascading Style Sheet

Cascading Style Sheet, or CSS, is another fundamental piece of a website. As we have mentioned before, it goes hand in hand with HTML. With CSS files and functions, the developer can directly control how the information is presented to the user. For example, with the relevant functions, we can choose to display a text in bold format or not. We can organize the text in different colors, with different backgrounds, different sizes and many other options.

3.2.9.3. JavaScript

Another very important cornerstone of web technologies, is JavaScript. This scripting language allows the developer to control the behavior of web applications. It is similar to high level programming languages such as C and Java, and therefore we are able to manipulate elements to fit our needs and create functions which will allow us to create an interactive web application for the user and provide them an intuitive way to utilize our product.

3.2.10. Front-End Frameworks

A very important aspect of our project is the user interface. We want our users to have a easy to use interface that provides them with all the information they need with ease of access and at the same time in a pleasant way. Therefore, it is important to utilize design aspects that will allow that. In the next sections, we will discuss front-end frameworks that will allow us to provide such experience for our users.

3.2.10.1. Bootstrap

One of the most commonly used front-end framework is Bootstrap. Created in 2010 by Mark Otto and Jacob Thornton Bootstrap has seen a wide adoption by mane web designers given it simplicity and its visual appeal. It is a framework that allows large customization of a web page, ranging from alterations to the typography to how the contents are organized within the viewport. Bootstrap works together with CSS and JavaScript to provide such visual experience to the end user. Even though Bootstrap allows us, as the developer, to customize our user interface in a lot of different ways, exactly because this is a framework that has become so popular, we have decided we would use something different in order to have a greater impact with the visual appearance of our project and to be somewhat different from the most common visual style used in many popular websites nowadays.

3.2.10.2. Material Design Bootstrap

As we have previously discussed, we will not be using Bootstrap; however, we will be using a very similar framework which is based on Bootstrap. That is Material Design Bootstrap. We believe that Bootstrap provides great customization, and as mentioned, we also believe that such customizations have become somewhat repetitive. Meanwhile, we as a group, also find Google’s design initiative to be visually appealing. Because of that, we decided to utilize a framework that combines both of the best worlds. Therefore, we will be using as the framework for our visual interface, Material Design Bootstrap. With this technology, we will be able to provide the users of our product with a beautiful interface that is similar to what they are used to, and therefore allowing the usability to be easy, and also with an appealing design so it is pleasant to use. It is worth noting that some features of MDB are paid – as opposed to Bootstrap which is free. However, this is not much of an obstacle, since we believe we can achieve sufficient usability of our product with the free elements they offer.

3.2.10.3. Foundation

Another popular design framework is Foundation by ZURB. Foundation is also a recent framework that has seen wide adoption across many websites. While we also find the elements and customization provided by this framework also visually appealing, we also believe that its documentation is lackluster. Because of that, we have decided not to adopt such design.

3.2.10.4. Materialize CSS

A framework that is also worth mentioning is Materialize CSS, created by a group of students from Carnegie Mellon University, Alvin Wang, Alan Chang, Alex Mark, and Kevin Louie. Materialize CSS also offers customization of elements that is attractive to us, and that is why we have considered this framework. We believe that we would be able to

build an easy to use and visually pleasing website with such framework. Because of this, we have not eliminated this option as one of our final candidates, even though Material Design Bootstrap is the framework that will most likely be used in the final product. However, if MDB proves to not be sufficient to achieve our goals or the need of paid elements becomes necessary, we will certainly switch to Materialize CSS, as it is free of charge and can also provide us with the necessary customization.

In figures 4, 5, and 6 we can see a comparison between our top choices for the front-end framework.

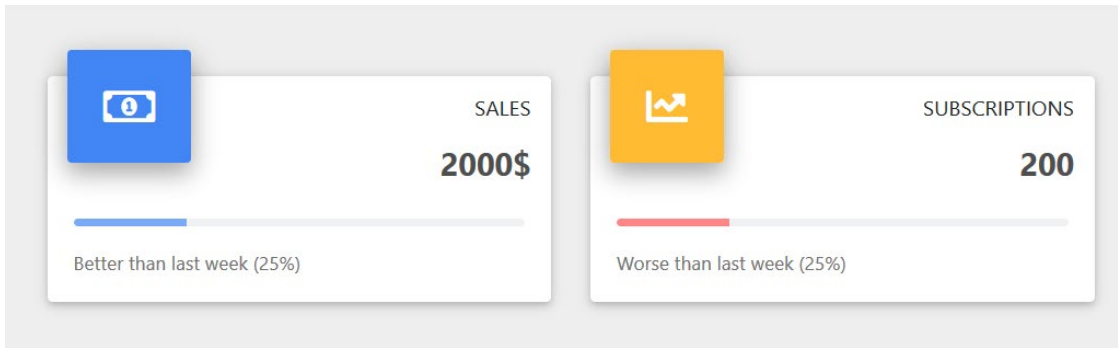

Figure 4. Example of Material Design for Bootstrap Component

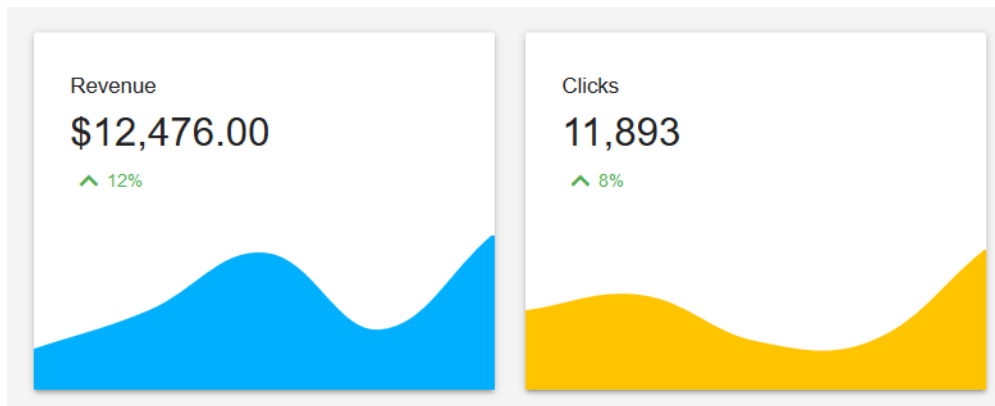

Figure 5. Example of Materialize CSS Component

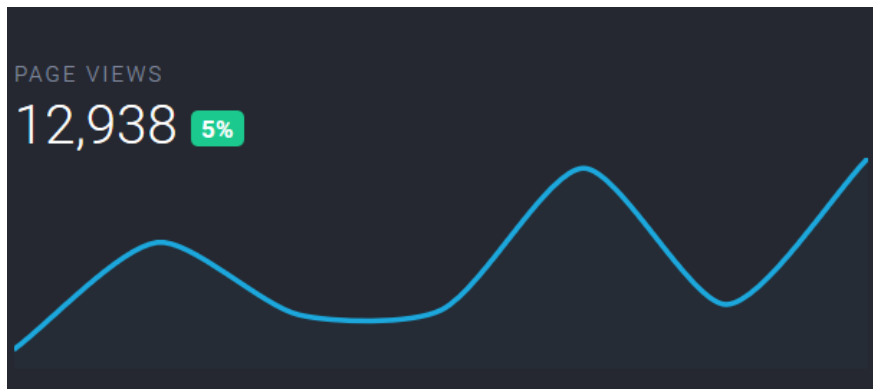

Figure 6. Example of Bootstrap Component

As we have mentioned before, we believe that the usage of Bootstrap as a front-end framework has become so popular that it has lost its appeal. Because of that, we have chosen to work with Material Design for Bootstrap that give us and our end user a refreshing appearance with functionalities that are already known to them.

3.2.11. Infrared Sensing Technologies

Infrared sensors can be utilized to monitor temperature due to blackbody radiation. We have chosen a passive infrared sensor (PIR) for detection of users and a near infrared sensor (NIR) for fire detection. This section will be utilized to look at the advantages and disadvantages to using this technology for our project as well as the challenges we will need to overcome.

3.2.11.1. Passive Infrared (PIR) Sensing

A passive infrared sensor is a pyro-electric sensor which is sensitive to infrared radiation. PIR sensors detect a change in infrared activity and will output either an 'on' or 'off' signal corresponding to a 3V or 0V output. They are energy efficient due to the 5V input voltage and an input current lower than 50mA, which makes this a good selection for our system to be cost effective in terms of energy usage. The sensors themselves have a relatively inexpensive unit cost which lowers the base expenses of our system.

The PIR sensor consists of two separate semiconductor materials with sensitivity to infrared radiation. Each of these correspond to a certain area, and these areas are consistently being refreshed and updated every blockade period which is on the scale of seconds. [Home Automation with PIR] When someone walks in from of one portion of the sensor there is a positive differential change in the level of infrared radiation, so the sensor turns on. The opposite happens when someone leaves the sensor zone: a negative differential in infrared radiation occurs and the sensor turns on. The working mechanisms of the system are shown in figure 7.

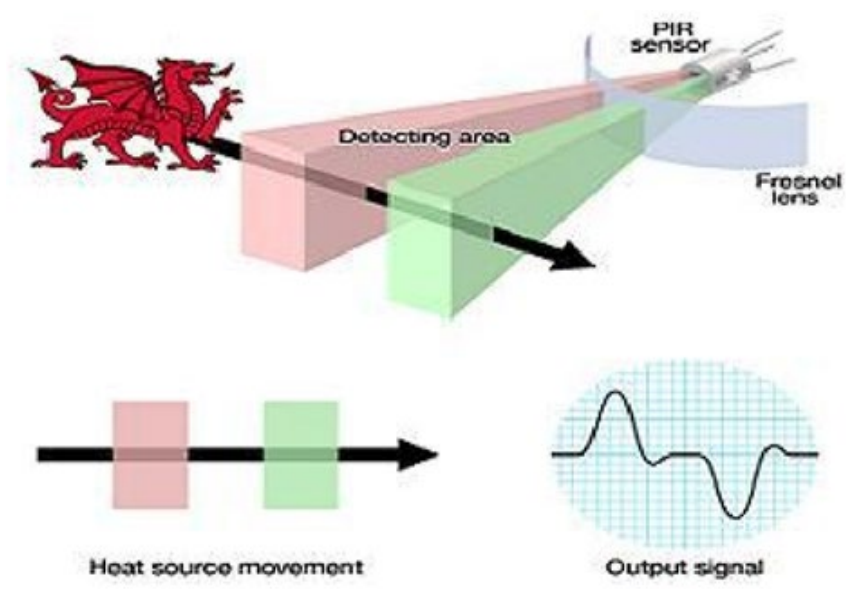

Figure 7. Working Mechanisms of PIR sensor [1]

One challenge that the PIR sensors pose to our system is that they can detect human presence accurately only when the person is in motion. The sensors are designed to only see when there is a difference in infrared radiations which only occurs when someone is walking into or out of the sensor area. Small changes may occur and trigger the sensor when someone is moving within the sensor zone, but whenever someone is in the sensor zone and still the sensor cannot detect them.

3.2.11.2. Near-Infrared (NIR) Sensing

Near-infrared sensing techniques have been utilized in many different experiments and projects for temperature mapping and detection. The near- infrared portion of the electromagnetic wave spectrum is between 0.7-1.1 microns. There are many devices which can detect and map radiation in this range such as charge-coupled devices (CCDs) and photodiodes. A CCD camera can both detect the radiation and map it in an array of pixels which produces a full picture. We've chosen to use a photodiode in our experiment because it is low cost and can still detect fire, and since we aren't trying to actually map it in our system it is a useful tool.

A NIR CCD camera could potentially be used to make our fire detection system more reliable because it has many features which allow the camera to discern between noise sources and an actual fire. One study used a CCD camera which operated in the UV, visible, and NIR spectrums and it utilized the UV spectrum for detection on the OH and CH bands at 314.3 and 390 nanometers.[3] It used the visible spectrum for the detection on CH bands at 431.4 and 473.7 nanometers and C2 bands at 516.5 nanometers. Detections on these bands are utilized for trigger verification. The main spectrum for this device was in the NIR spectrum between 750 and 1100 nanometers.

3.2.11.3. Infrared Lenses

We've decided to put a lens in front of our NIR sensor to increase its range of detection. There are several candidates for the composition of the lens and we noted the characteristics of each including transmission wavelengths, reflectance, refractive index, and cost. We will also analyze the type of lens and characteristics such as focal length which will be ideal for our sensors.

N-BK7

This material has a refractive index between 1.5 and 1.52 in our emission spectrum which will make the material transparent due to the small disparity between the indexes of the air and the glass. Figure 8 shows the transmission spectrum of N-BK7 and we can observe it is around 90% up to 2 microns. N-BK7 is relatively inexpensive and we can buy a lens for our purposes for between twenty and fifty dollars. This is the most likely candidate for our NIR sensors.

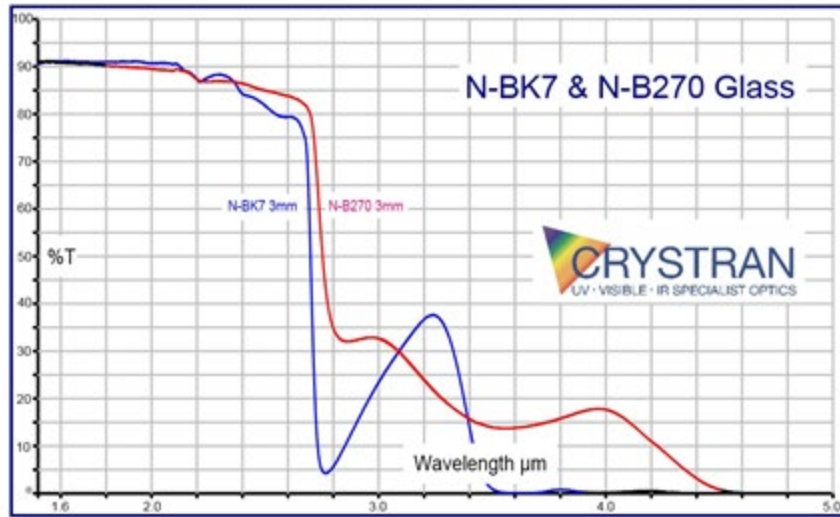

Figure 8. Transmission Spectrum of N-BK7

Source: <https://bit.ly/2LyUzbq>

Zinc Selenide

This material has a refractive index between 2.48 and 2.67 in our emission spectrum so reflectance will be high due to the large disparity in the refractive indexes of air and the glass. Figure 9 shows the transmission spectrum of Zinc Selenide and we can see that transmission is much lower than N-BK7 at around 70% for our spectrum. Zinc Selenide is a relatively expensive material so this glass will not be used for our sensors.

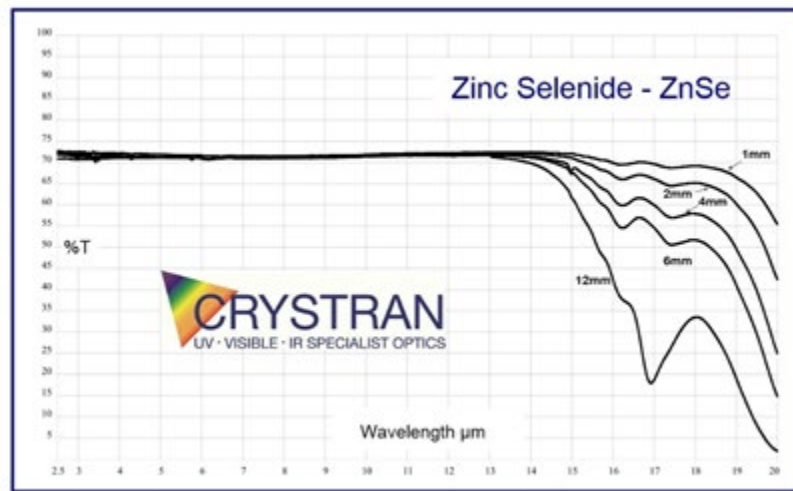

Figure 9. Transmission spectrum of Zinc Selenide

Source: <https://bit.ly/2LyUWTm>

Calcium Fluoride

This material has a refractive index of between 1.42 to 1.43 in our emission spectrum which is great for our purposes because there is a small disparity between the indexes of air and

the glass, so reflectivity will be low. Figure 10 shows the transmission spectrum of Calcium Fluoride and we observe that the signal would have a transmissivity of around 95%. This is most likely going to be the best choice for glass in terms of transmissivity, but most lenses cost upwards of a hundred dollars, so it doesn't fit into our budget well. This would be an ideal material to use for any improvements because it allows for higher transmission than most glasses and it is transmissive up to around 7 microns.

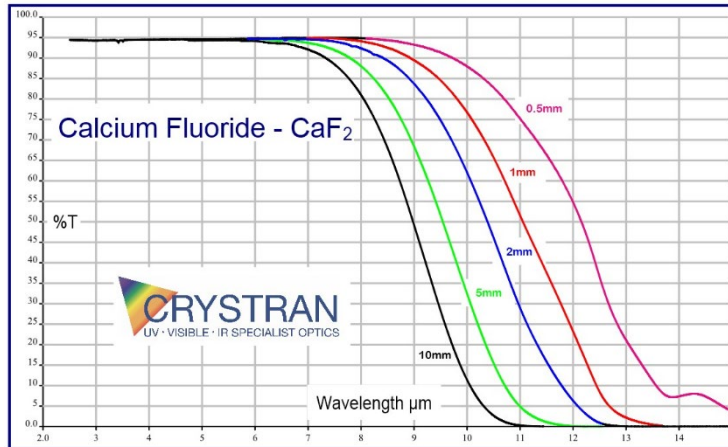

Figure 10. Transmission Spectrum of Calcium Fluoride

Source: <https://bit.ly/2YfWBDA>

Sodium Chloride

This material has a refractive index between 1.53 and 1.54 in our emission spectrum so this material will have low reflectivity due to the low disparity in refractive indexes of air and the glass. Figure 11 shows the transmission spectrum of Sodium Chloride and we see that transmission is around 90% for our emission spectrum which makes this a good material to use for our NIR sensor. The price for a Sodium Chloride lens is between forty and a hundred dollars for a half-inch lens, so it may still be reasonable to use as a lens material.

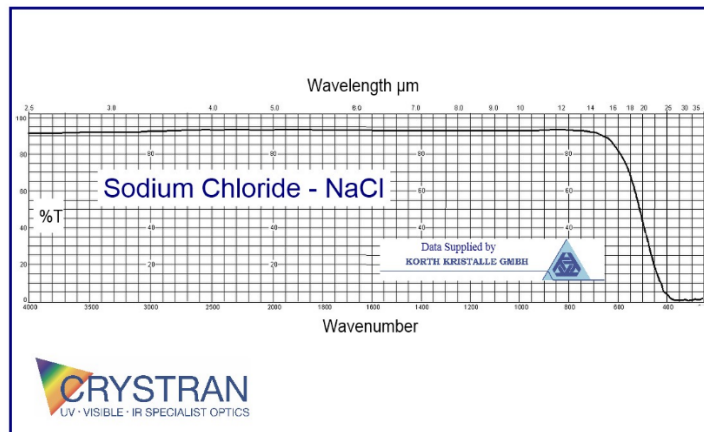

Figure 11. Transmission Spectrum of Sodium Chloride

Source: <https://bit.ly/2xXIRj8>

Magnesium Fluoride

This material has a refractive index between 1.37 and 1.39 which makes this material very transmissive in our emission spectrum due to the large disparity in refractive indexes. Figure 12 shows the transmission spectrum of Magnesium Fluoride and we see that the transmission is around 95% for our emission spectrum which makes it a good candidate for our NIR sensor. The price of a Magnesium Fluoride lens for our purposes is around sixty to one hundred dollars, so it would be reasonable to use it.

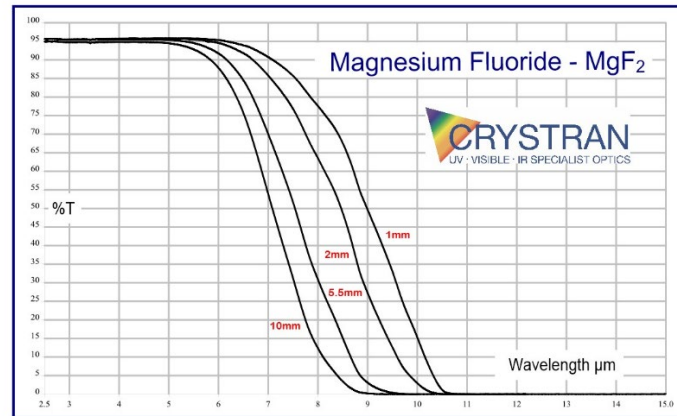

Figure 12. Transmission Spectrum of Magnesium Fluoride

Source: <https://bit.ly/30PIYal>

Lens Characteristics and Choice.

We've decided that a lens made of N-BK7 would be the most ideal for our project's purposes and constraints. The transmission spectrum is exactly in the emission spectrum we're testing for and it has very low reflectivity. The price difference between a half inch and full inch lens is approximately two dollars, so we decided to get a full inch to capture more incident light. The full inch lens will capture approximately four times the incident light that the half inch lens can, and it doesn't interfere with any of our current design. The full inch lens will cost \$24.41 from Thorlabs

The lens will have a focal length of one inch because this is the shortest focal length available from Thorlabs and it will provide us with the best field of view for our sensors. It also is good for our design for the sensor housing because we want it to be as compact as possible to make mounting easy for the user. The clear aperture of our lens is 0.9 and we intend to use all of it in our design by mounting it circularly onto the lens mount at the top of our sensor housing. We've decided to use a plano-convex lens because it will capture light from outside the sensor while simultaneously letting less light be reflected and transmitted out of the sensor housing.

3.2.12. Blackbody Radiation

The main electromagnetic emission from fire is blackbody radiation so we have chosen to utilize infrared photodiodes as the detection method. Figure 13 shows the blackbody emission spectrum of a "typical" hydrocarbon fire. We can clearly see that the middle to long infrared regions have the most intense radiation.

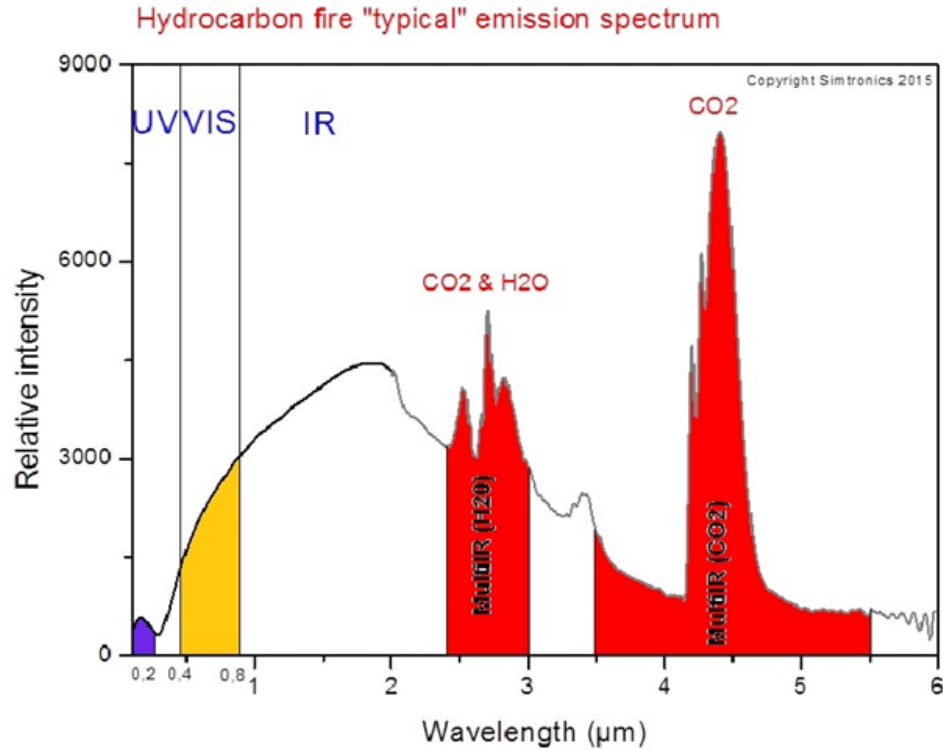

Figure 13. Blackbody Emission Spectrum of “Typical” Hydrocarbon Fire

Source: <https://bit.ly/2Xrkle0>

A large amount of noise is going to leak into our system through solar emissions, so we must observe both the blackbody spectrum of the sun and the transmission spectrum of the sun through Earth’s atmosphere. Figure 14 shows the transmission spectrum of the sun through the atmosphere. We can see the peak is close to 500nm. There are several sections where molecules in the atmosphere block incoming radiation. Around 940nm we can see a large dip in the transmitted radiation due to absorption by water. This is a good spot to utilize for our fire detection because there will be less environmental noise from the sun. We can also see drops around 1.1µm, 1.5µm, and 2µm wavelengths as well as dropping to almost nothing beyond 2.5µm. This demonstrates that near infrared and mid-infrared detectors will be most effective for fire detection.

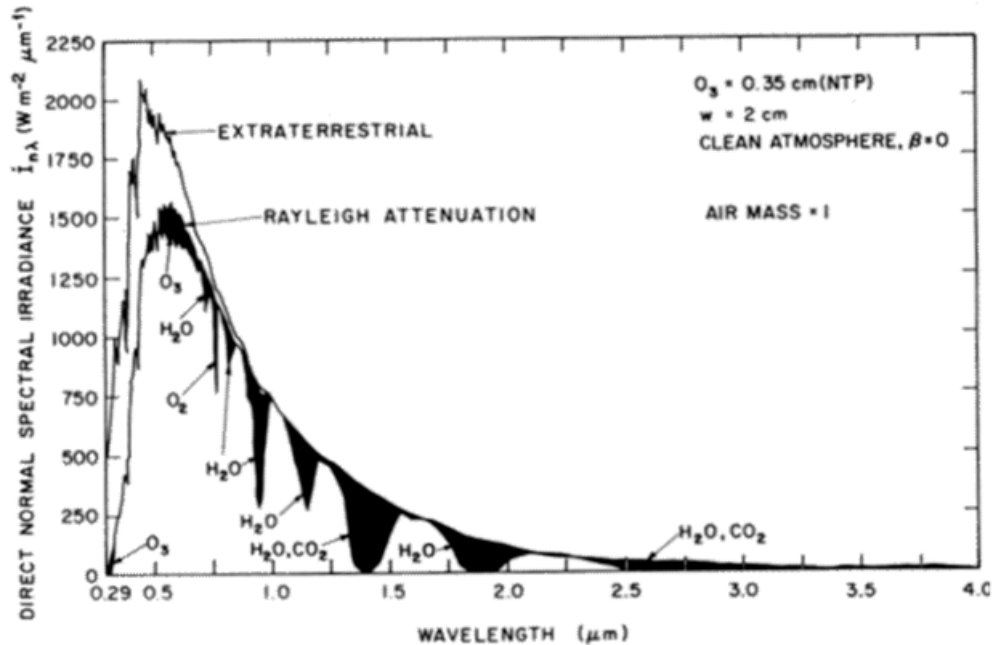

Figure 14. Transmission Spectrum of the Sun

Source: <https://bit.ly/2XMKLA1>

3.2.13. Raspberry Pi 3 Model B+

The Raspberry Pi 3 Model B+ is the final revision of the Raspberry Pi 3 range of single-board computers. The Pi is an ARM-based system with a Broadcom BCM2837B0 Cortex-A53 (ARMv8) 64-bit SoC CPU. The specifications of the device are listed in tabular format below. [11]

Table 8 Raspberry Specifications

Component	Specifications
CPU	Broadcom BCM2836B0 Cortex-A53 (ARMv8) 64-bit SoC @ 1.4 Ghz
Memory	1GB LPDDR2 SDRAM
Wireless Networking	2.4GHz and 5GHz IEE 802.11.b/g/n/ac wireless LAN, Bluetooth 4.2, BLE
Wired Networking	Gigabit Ethernet over USB2.0 (maximum throughput 300 Mbps)
Pin I/O	Extended 40-pin GPIO header
USB	4 USB 2.0 Ports
Digital Video	Full-size HDMI
Analog AV	4-pole stereo output and composite video port
Storage	Micro SD port (loaded with 32GB SanDisk microSD with Raspbian installed for the purposes of this project)
Power	5V/2.5A DC Power input

This is the model of pi that we have selected for use in our project, as it provides all the necessary features required for the implementation of our system at a reasonable price. The 1.4 GHz ARM core should be adequate for the purposes of our project, as most of the requisite computing tasks will be relatively light-weight. The same can be said of the gigabyte of memory, especially considering the fact that there will be no need to run the system with a graphical interface. The wireless networking support for Wi-Fi is robust and meets our requirements on that front, as do the ethernet specs. The pin I/O will be used where direct interface between the hub and a sensor or other component is useful or necessary, and the micro SD port allows for a variety of storage cards of different sizes to be installed. Although the Raspbian image installed to the card has a footprint of approximately eight gigabytes, this still leaves the vast majority of the space on the 32-Gigabyte SD card free, and this space will prove more than enough for the purposes of our project.

3.2.14. Raspbian

Raspbian is a Debian-based operating system which is the officially-supported operating system of the Raspberry Pi platform. Raspbian is optimized specifically for use with the line of low-performance ARM CPUs that the Pi uses and is therefore a better choice than making use of other, more generalized ARM operating systems which might otherwise be compatible. Its status as a ‘default’ operating system for the Raspberry Pi also means that information and documentation is highly available. Because the Raspberry Pi model that has been purchased does not come with a pre-installed version of Raspbian, it has been installed manually onto an SD card, which is then installed in the Pi itself.

The latest version of the Raspbian operating system is available from the Raspberry Pi Foundation’s official website [10] and was downloaded and written to an SD card using the dd utility with the command:

```
dd bs=1M if=2019-07-10raspbian-buster-full.img of=/dev/sdb
```

From there, the micro SD card was inserted into the Pi, which booted Raspbian without issue.

3.2.15. Project Management Tools

As a group, we are working with many different files, ideas, coding snippets, and different sources. As we all have different availability throughout the day, it is important for us to always be able to communicate to other members of the group in an efficient manner. In the following sections, we will discuss the tools we have utilized to do so.

3.2.15.1. Source Control

As a group, we are working with many different files, ideas, coding snippets, and different sources. As we all have different availability throughout the day, it is important for us to always be able to communicate to other members of the group in an efficient manner. In the following sections, we will discuss the tools we have utilized to do so.

One option under consideration for source control is Git. Not only is Git a highly flexible and mature system for source control and version management, but also boasts a selection of sites which offer repository-hosting free of charge. Git would allow our group to both

collaborate asynchronously on the project, assisting in version and branch control, and would also help to ensure that there is little to no chance of catastrophic data-loss as a result of a hard-drive failure or accidental deletion, as the project data would be stored not only on the machines of group-members, but also backed-up by the chosen hosting provider.

Git also offers convenience in the form of branches, which would allow group members to experiment with bonus or wishlist features without affecting core development, and then merge said features back into the core branch of the project if they happen to bear fruit. Git tools are also ubiquitous, either as stand-alone programs, built into various IDEs either by default or as community plug-ins, can be used from both command-line and through graphical interfaces, and are available on practically every platform from Windows to Mac to Linux.

3.2.15.2. Microsoft Office Suite

A big portion of this project is also the creation of the documentation for it. Because we are all contributing to the same document, it is also important that each of us is able to do so without interrupting the work of someone else. We therefore, took advantage of the functionalities of Office 365, provided to us by the University of Central Florida in partnership with Microsoft. Namely, in order to create such document, we used Microsoft OneDrive, to store it, and Word, to edit it.

4. Related Standards and Design Constraints

4.1. Related Standards

4.1.1. IEEE 802.11 Wi-Fi

Wi-Fi provides a robust means for carrying out digital communications over a local area network and is supported by a wide range of devices and can be integrated into devices which do not directly support it via the use of pre-programmed standalone modules. Wifi will be used as a means of achieving wireless communication between the devices used in the project, and as a means of connecting the central hub to the internet via a Local Area Network.

4.1.2. Universal Serial Bus

The Universal Serial Bus (USB) technology is a standard for facilitating hardware communication between computers, peripheral devices, and other computers. It is another standard that is practically ubiquitous in its implementation in consumer devices and is therefore a key choice when it comes to methods for extending the functionality of devices which are being controlled by the system or that of the central hub itself.

4.1.3. HTTP

Hypertext Transfer Protocol is a standard allowing for the transference of media over the World Wide Web. HTTP is instrumental to our project plan as we have chosen to implement our user interface as a web-based scheme in order to take advantage of the fact that most consumer electronic devices have access to a web browser which can display and interact with said content, saving the effort of having to design device-specific clients and

interfaces. Methods which allow the client to send information to the server such as the HTTP POST method will be instrumental for tasks such as the authentication of users.

Additionally, it is worth mentioning that REST webservices most commonly makes use of HTTP for data transmission, including the HTTP methods such as GET, POST, etc when it comes to defining operations carried out through a webservice API. This is another way in which HTTP is an important standard when it comes to the operation of our project, as we have chosen to implement REST-Based webservices in order to create an API which will improve the ease of communication between the server and other components of the smart home system.

4.1.4. Hypertext Markup Language

The Hypertext Markup Language is a standard which defines the structure and layout of documents and media designed to be transmitted over the Internet via the Hypertext Transfer Protocol. HTML serves as the backbone for the web pages which will serve as the primary means of interfacing with the server, and can be supported by other standards and technologies such as CSS, JavaScript, Angular.js, etc. Which provide a more responsive or visually impressive front-end experience.

4.1.5. Cascading Style Sheet

CSS is a standard for managing the look and feel of webpages across the entirety of a site and is commonly used in tandem with HTML for web page design. The ability to create a single CSS sheet which can be re-used to define the visual properties of an entire set of webpages is useful for ensuring visual consistency across the webpages produced for this project and as a means of reducing workload, and the fact that CSS support is ubiquitous ensures that its application to the project requires essentially no extra effort.

4.1.6. Coding Standards

As we have mentioned in previous sections and it will be shown in more detail in following sections, the software portion of this project will be mainly written utilizing the Python programming language. As such, it is necessary for us, as developers, to follow a coding convention, styling, and standard, namely PEP 8. An example is shown in figure 15. These guidelines will also serve as a tool to streamline the process of writing many different sections of the code with different people working on it. Also, the main purpose of following these guidelines is to improve the readability of our code, not only for our own benefit, which will help us write better and code and debug it easily, but for the benefit of a third party in case it comes the time were the code will be shared.

```
# Aligned with opening delimiter.  
foo = long_function_name(var_one, var_two,  
                          var_three, var_four)
```

Figure 15. Example of PEP 8 Guideline

Our back-end framework Django also follows PEP 8 as it is written in Python. Django also has its own coding style which we will be following closely to keep the uniformity and

again improve our code readability. In figures 16 and 17, a comparison between a correct and a wrong coding style is shown.

In order for us to easily follow such guidelines mentioned above, since most of us will be using Visual Studio Code by Microsoft, we can simply install an extension that will help us format the code with these guidelines in mind.

```
class Person(models.Model):  
    first_name = models.CharField(max_length=20)
```

Figure 16. Correct Guideline Example – Django

```
class Person(models.Model):  
    FirstName = models.CharField(max_length=20)
```

Figure 17. Wrong Guideline Example – Django

4.1.7. ZigBee

ZigBee is an open-source standard for the creation of personal-area mesh networks. Each transmitter has relatively low range and is typically limited to 10-100 meters line-of-sight transmission, but the range of the network can be extended by allowing devices within the network to relay transmissions from one to the other. ZigBee is best suited for low-range, low-bitrate use cases, and offers significant energy-savings as compared to other protocols designed for higher-volume data transmission, such as Wi-Fi, making it ideal for battery-powered applications. Although Wi-Fi has been chosen as the primary methodology of wireless communication for this project, Support for ZigBee-based devices remains a promising choice as either a backup or extra goal.

4.1.8. JSON

JSON (Javascript Object Notation) is an open standard which defines a human-readable format for organizing transmissible data in attribute-value pair form. Though derived from Javascript, JSON can be used by programs written in numerous languages as a means of serializing data for transmission over a network in a format which is agnostic to device architecture and programming language, making it a prime candidate for use in applications such as webservice APIs and other systems which demand that heterogeneous devices be capable of communicating with one another.

The primary use of JSON in this project is to facilitate communication between separate devices operating as part of the system by allowing complex objects with numerous attributes and/or secondary embedded JSON objects, to be serialized and transmitted via computer networks, whether that be over the internet or a LAN. Another reason the JSON standard is used in this project lies in the fact that we plan to build the webservice portions of the system on a REST architecture, and although REST can support numerous formats for data-transmission, JSON is one of the most popular and well-rounded options for use in such an application.

```
Object {
  AlertStatus: false
  Device: Object {
    Black: true
    Orange: false
    Red: false
    Temperature: 76
    White: true
  }
  DeviceType: "Thermostat"
  id: 1
}
```

Figure 18. Example of JSON object structure with nested object

4.2. Design Constraints

4.2.1. Economic and Time Constraints

Because our group is not making use of sponsors, the cost of the materials required for the implementation of the deliverable must remain relatively low, preferably beneath \$100 per individual on the team, or \$400 total. Keeping the cost of materials low has the added bonus of helping to make any final system created economical for potential mass production. However, cost-effectiveness must also be balanced with realistic time-constraints, as the final deliverable must be ready for presentation by the deadline. To that end, low-cost, easy to work with, and standardized hardware designed and sold for prototyping and personal project applications, such as the Raspberry Pi microcomputer, will make up the bulk of the materials purchased for the project, with the expectation that any successful prototype produced can potentially make the jump to specifically-manufactured hardware if necessary.

4.2.2. Environmental and Social Constraints

The environmental constraints facing this project are twofold, in the sense that the product should, by design, have as little impact in terms of materials and power-usage as feasible. To that end, long product lifespan should be sought by ensuring that all hardware used operates under conditions that do not damage or otherwise negatively affect the devices in question in such a way as to reduce their lifespan. This includes any battery cells used as a power-source solution for any component of the system, by reducing battery usage where possible and, in the case of rechargeable cells, encouraging healthy discharge and recharge cycles wherever possible. In terms of social constraints, the product should act to improve the ease and day-to-day life of the end-user, and thus care should be taken to ensure that the features implemented are implemented in such a way as to actually be useful rather than uncomfortable or convoluted. Sometimes this may prove to be more difficult than it seems at first glance, for example, the passive infra-red sensors which are slated for use as the primary means of detecting whether a room is occupied for the purpose of turning on the lights when a user enters primarily work on motion through means of detecting changes in infra-red radiation. To that end, it is difficult to determine whether a user has remained

in a room after entering and remaining still for a long period of time, i.e. while watching television, and creative solutions will be required to ensure that the system does not become confused and act against the interests of the user due to a lapse in detection.

4.2.3. Health and Safety Constraints

Due to the low voltages and low-power wireless transmission involved in the implementation of the smart home system, there are few key health and safety concerns related directly to the operation of the system itself. However, there is potential for key misunderstandings between what the product has been designed to do and what the user expects it to be capable of which might result in safety concerns. For example, a core feature of our product is for it to act as a supplementary fire-detection system via the use of near-infra-red (NIR) sensors tuned to detect open flames. Though the purpose of this system is to *improve* safety by alerting the user to a potential fire in high-risk areas of the household, there is potential for danger if the user does not understand that the system is not designed to be a replacement for a standardized fire alarm and smoke-detection system. It is important that the user is informed clearly and is aware at all times that this aspect of the system is meant to be a supplement to existing fire-detection and prevention technology, and that it cannot of its own accord notify emergency personnel and should not be used as a replacement for a code-compliant fire alarm system.

4.2.4. Manufacturability Constraints

By and large, the largest concerns when it comes to manufacturability constraints include the ease of manufacture in terms of processes and automation, and the cost of manufacturing the system. There are many electronic components of the system which are, by and large, already mass-produced in and of themselves, and as such the physical manufacturability of such components is outside the scope of our group's concern. Where manufacturability is a concern is in such components that are produced either through custom modification of existing devices or through original design, potential examples being infra-red sensors using special lenses to improve the performance of the sensors in question, or electronic locking devices which have been modified to allow for the use of nonstandard networking hardware in order to connect them with the smart-home system. In such cases, care must be taken to ensure that the modifications made are clearly documented, simple enough to roll into a manufacturing process if necessary, and that any components of the system which are implemented in the prototype by modifying a commercial product can be produced 'from scratch' in a potential final product so as to avoid intellectual property infringement.

The other primary concern when it comes to manufacturability is the cost of the materials and processes involved. Similar to the economic constraints section, lower cost improves the viability of manufacturing the system and should be sought out wherever it does not compromise the core design goals of the project. To that end, components should be selected for viability in price and long-term manufacturability, along with immediate availability (I.E, avoiding technologies which have been introduced so recently as to be difficult to acquire at a reasonable price, such as Bluetooth 5.1).

4.2.5. Political Constraints

As a service with a web-based component, the system will be required to comply with the laws of any jurisdiction in which it is deployed. In order to keep the scope of the project reasonable, compliance will mostly be sought with existent United States. Because we do not expect to be receiving or working with financial information, the legal requirements in that sphere can be more or less eliminated. All the same, in the event that such a product as ours does go into production, care will have to be taken to ensure that compliance is met with any other internet data regulations as exist in the United States governing information privacy, I.E, as regulations such as CalOPPA exist which suggest that a privacy policy at the very least should be included in any website that collects personally identifiable information. All the same, since the goal is to collect and keep as little personally identifiable information as is necessary to allow the design goals of the project to be met, it is doubtful that significant issues regarding political constraints will be met.

4.2.6. Ethical Constraints

The primary ethical constraints implicit in this project relate to the data and information which might be collected by a system entwined with the user's home. To that end, developers and operators of the system have a responsibility to the end-user to collect as little personally identifiable information as possible, and to ensure that any information which is collected cannot be easily accessed without proper motive. Because the smart home system will require that devices be integrated with the user's home networks, it is also imperative from an ethical point of view that the system not be easily compromised by unlawful third parties. Poor security is one of the largest issues facing IoT applications in the modern day, and avoiding such pitfalls, both in the user's home and in the Internet-based support systems to which it connects is imperative. Likewise, contingencies designed to lessen the exposure of personally identifiable information in the event of a breach, such as hash-and-salt password management schemes, should also be implemented in addition to proper security. By taking these concerns into account and constructing our system accordingly, we should be able to provide a system which the end-user can make use of without worrying about potential pitfalls when it comes to security or safety, and perhaps even more importantly, we will have created a system which will not act to compromise those aspects of privacy and security.

4.2.7. Software Prototyping Constraints

Software prototyping in terms of this project's scope will mostly follow a rapid-prototyping paradigm, with programs designed for testing and exploring the means and idiosyncrasies in communication between various components of the system, i.e. between a central hub device and sensors and devices placed throughout the home, or between the central hub and the webserver, but which are not necessarily included in the final product. To that end, prototypes should largely be used as a proof of concept for core design features and as a means by which interconnectivity can be confirmed and tested. Examples might be a program to act as an example of how the central hub will connect to, carry out authentication with, and receive commands from the webserver. Another example might be a program whose feature set consists solely of being able to turn a light on and off via communication with the central hub. Prototyping should thus be constrained to simple and 'quick' tasks, in order to leave as much time as possible to create, polish, and otherwise

complete the feature-set of the software components of the project as a whole. One other point of note in regard to software prototyping constraints is that, although we will be developing a networked application, we have no way of easily carrying out a network stress-test which would provide an adequate picture of the system's ability to handle a large number of concurrent users at this time. However, the importance of creating and maintaining a system which can handle concurrent users without significant bottlenecks remains.

4.2.8. Testing Constraints

There were many constraints for testing both the infrared sensors due to the need for both fire and proximity. We couldn't use the designated senior design room for the passive infrared sensors because it is both too small and too crowded to get accurate readings. We also couldn't test the near infrared photodiode in the senior design room because I needed to use an open flame and that room doesn't allow open flames. We decided that we would perform most testing at L3 Technologies since there is both room for the PIR sensors and we can use open flames with a hot work permit which is included in figure 19. We were not able to use the propane source at this location, so the larger flame testing is postponed until we find a suitable location.

HOT WORK PERMIT

STOP!
 Avoid hot work when possible! Consider using an alternative cold work method.

This Hot Work Permit is required for any temporary operation involving open flames or producing heat and/or sparks conducted outside a Hot Work Designated Area. This includes, but is not limited to: brazing, cutting, grinding, soldering, torch-applied roofing and welding.

Instructions for Permit Authorizer	Part 1
1. Specify the precautions to take. 2. Fill out and keep Part 1 during the hot work process. 3. Issue Part 2 to the person doing the job. 4. Keep Part 2 on file for future reference, including signed confirmation that the post-work fire watch and monitoring have been completed. 5. Sign off final check on Part 2 .	Required Precautions <input checked="" type="checkbox"/> The fire pump is in operation and switched to automatic. <input checked="" type="checkbox"/> Control valves to water supply for sprinkler system are open. <input checked="" type="checkbox"/> Extinguishers are in service/operable. <input checked="" type="checkbox"/> Hot work equipment is in good working condition. Requirements within 35 ft. (10 m) of hot work <input checked="" type="checkbox"/> Shield combustible construction using FM Approved welding pads, blankets and curtains. <input checked="" type="checkbox"/> Remove combustibles or shield nonremovable combustibles using FM Approved welding pads, blankets and curtains. <input checked="" type="checkbox"/> Isolate potential sources of flammable gas, ignitable liquid or combustible dust/flint (e.g., shut down equipment). <input checked="" type="checkbox"/> Remove ignitable liquid, combustible dust/flint and combustible residues. <input checked="" type="checkbox"/> Shut down ventilation and conveying systems. <input checked="" type="checkbox"/> Remove combustibles and consider a second fire watch on opposite side of floor, wall, ceiling or roof when openings exist or thermally conductive materials pass through. <input type="checkbox"/> Is work on a combustible roof? If yes, treat as a "Hot Work High-Risk Area" and provide ADDITIONAL REQUIRED PRECAUTIONS below.
HOT WORK BY <input checked="" type="checkbox"/> Employee <i>Anten</i> <input type="checkbox"/> Contractor	Hot work on/in closed equipment, ductwork and piping <input type="checkbox"/> Isolate equipment from service. <input type="checkbox"/> Remove ignitable liquid and purge flammable gas/vapor. <input type="checkbox"/> Prior to work, and/or during work, monitor for flammable gas/vapor. LEL readings! <input type="checkbox"/> Remove combustible dust/flint or other combustible materials. <input type="checkbox"/> Is work on/in equipment with nonremovable combustible linings or parts? If yes, treat as a "Hot Work High-Risk Area" and provide ADDITIONAL REQUIRED PRECAUTIONS below.
DATE: <i>7-3-19</i> JOB NUMBER: <i>7</i> LOCATION OF WORK (BUILDING/FLOOR/OBJECT): <i>Production Floor</i> WORK TO BE PERFORMED: <i>Testing diode</i> NAME OF PERSON PERFORMING HOT WORK: <i>Chris Stevenson</i> NAME OF PERSON PERFORMING FIRE WATCH: <i>Same</i>	Fire watch/fire monitoring the hot work area <small>(Refer to FM Global Property Loss Prevention Data Sheet 10-3, Hot Work Management for guidance on categorizing hot work areas.)</small> <input checked="" type="checkbox"/> Perform a continuous fire watch during hot work. <input checked="" type="checkbox"/> Perform a continuous fire watch following hot work completion for <input type="checkbox"/> 30 or <input type="checkbox"/> 60 minutes depending on category. <input type="checkbox"/> Perform fire monitoring following fire watch completion for <input type="checkbox"/> 1 <input type="checkbox"/> 2 <input type="checkbox"/> 3 <input type="checkbox"/> 4 or <input type="checkbox"/> 5 hours depending on category.
I verify the above location has been examined, the Required Precautions have been taken, and permission is authorized for this work. PERMIT AUTHORIZER (PRINT AND SIGN): <i>M. Brown</i>	ADDITIONAL REQUIRED PRECAUTIONS: _____ _____ _____
THIS PERMIT EXPIRES ON (LIMIT AUTHORIZATION TO ONE SHIFT): DATE: <i>7-3-19</i> TIME: <i>12:33</i> AM/PM <input checked="" type="radio"/>	
Note: Emergency notification on back of form. Use as appropriate for your facility. Need more permits? Order additional Hot Work Permits at fmglobalcatalog.com or download the FM Global Hot Work Permit App via fmglobal.com/apps .	
	F2630 © 2016 FM Global (Rev. 08/2016) All rights reserved.

Figure 19. Hot Work Permit for Testing

We required both a power supply and an oscilloscope for the testing which limited the resources we had on campus, so we opted to rent an oscilloscope and power supply from CREOL. Technical difficulties have led to the rentals being delayed so we cannot continue with testing until those are available. We have arranged for later testing to occur in either the chemistry building or in one of our private domiciles.

The fire detection sensor design includes a half inch lens which is mounted onto an aluminum box containing the NIR photodiode. Both the lens and assembly weren't currently available due to both design time and shipping for the initial testing. We realized that it's difficult to keep the diodes pointed in the same direction during testing so further testing will take this into account.

5. Project Hardware and Software Design Details

5.1. Hardware Design Details

5.1.1. AC Thermostat Design

For the AC Thermostat Unit, we will have to meet these Requirements:

- Turn ON/OFF AC Fan, Compressor, Heater, and Pump if applicable
- Produce working outputs of 24Vac
- Accurately read ambient room temperature
- Use a display and have some button controls
- Have a profile smaller than 8"x6"x1"
- Support 18 AWG wires
- Have a Minimum working range of 30m

The components chosen for this unit meet or exceed these requirements. We will be using a set of 5V relay that can handle up 20A at up to 220Vac. The HLK-PM01 PSU will be able to provide ample power to our DC components. The components will be small enough to fit in a PCB that will be placed inside a rectangular case that will have a slot for a 1.5" square OLED display. The CTB0158-2 terminals will support up to 12 AWG wires so 18 AWG is no problem. The ESP8266 has a working range of 300m Line of Sight, so we should have no problem meeting the 30m range inside the home, this will have to be tested. We will be using a DHT22 Temperature and humidity sensor that has an accurate measurement with only a 2-5% deviation from actual room temp.

This design is considering a standard home AC system that is wired to use ~24Vac. The relay system controlling the Fan, Compressor, Heater, and Heat Pump (if applicable) will run on this 24Vac while the microcontroller, temperature sensor, and LCD screen require 5Vdc. To power the DC components, we will use an AC-DC supply module to power the system with +5VCC. This system shall remain Isolated from the 24Vac at the terminals. The typical AC system requires 5 terminals, Heat, Compressor, Fan, Pump, RedC (power) for Cooling System, RedH (power) for the heating system, and a Common terminal, see table 9 for a description of the functionality of these wires. The common terminal will ensure that the thermostat is provided with an uninterrupted power source.

Table 9 Terminals Descriptions

Color	Terminal Code	Purpose	Description
Red	R	24 VAC Power	This is the 24V power terminal. Most of the low-voltage thermostats work with this voltage although you can find them all the way up to 50V. It is not uncommon to find 2 red cables Rh and Rc powering the cooling and heating systems separately
Black	C	24 Vac Common	This is the common ground for the 24V
White	W	Heat	This is the terminal that energizes the heater
Yellow	Y	Compressor	This is the terminal that energizes the compressor
Orange	O	Rv On in Cool	O and B terminals interact with the reverse valve. The reverse valve controls the flow of refrigerant in the piping system, basically allowing for either cool or hot air.
Blue	B	Rv On in Heat	Same as the terminal O but to call for heat. It is common for the two terminals to be combined. The industry standard is when O/B is ON the system cools, and vice versa
Green	G	Indoor Fan	Controls the Fan if the system allows it.

Connecting the Power terminal to Heat, and Power to Fan will turn on the heater. Connecting the Power to Compressor, and Fan will start the Cool Air. Knowing this we can install have a line providing Vac power to the common terminal of the relays, the other terminals will be connected to one of the poles. We will only consider common AC wiring standards for the design; we will not be able to accommodate all systems with this unit.

To start with the design, the device will be using power directly from the Red terminal. Our DC components will all function with a VCC of 5V so to use the 24Vac line we will pass the voltage through a half-wave rectifier and then to the LM2596 module that will provide a steady voltage of 5V. This voltage will power the NodeMCU, the Temperature and Humidity Sensor, the OLED Display, the relay board, and the Dual 4-Channel Multiplexer. Since almost all our sensors and controlled components operate using either UART, SPI, or I2C, and since the NodeMCU has only one communications array, we will not be able to read or write data simultaneously to all those components. In our case, simultaneous communication is not needed, but to switch between different components we will use the multiplexer to select which sensor or module the MCU will send messages to. The OLED Display will be the only component not connected to the main board. The display will be mounted to the housing's hinged cover and connected to the board via a ribbon bus. Still to add to the design is some control buttons that will allow the manual setting for temperature. Below, you will find diagrams and schematics for the components needed, as well as the Bill of Materials for this device.

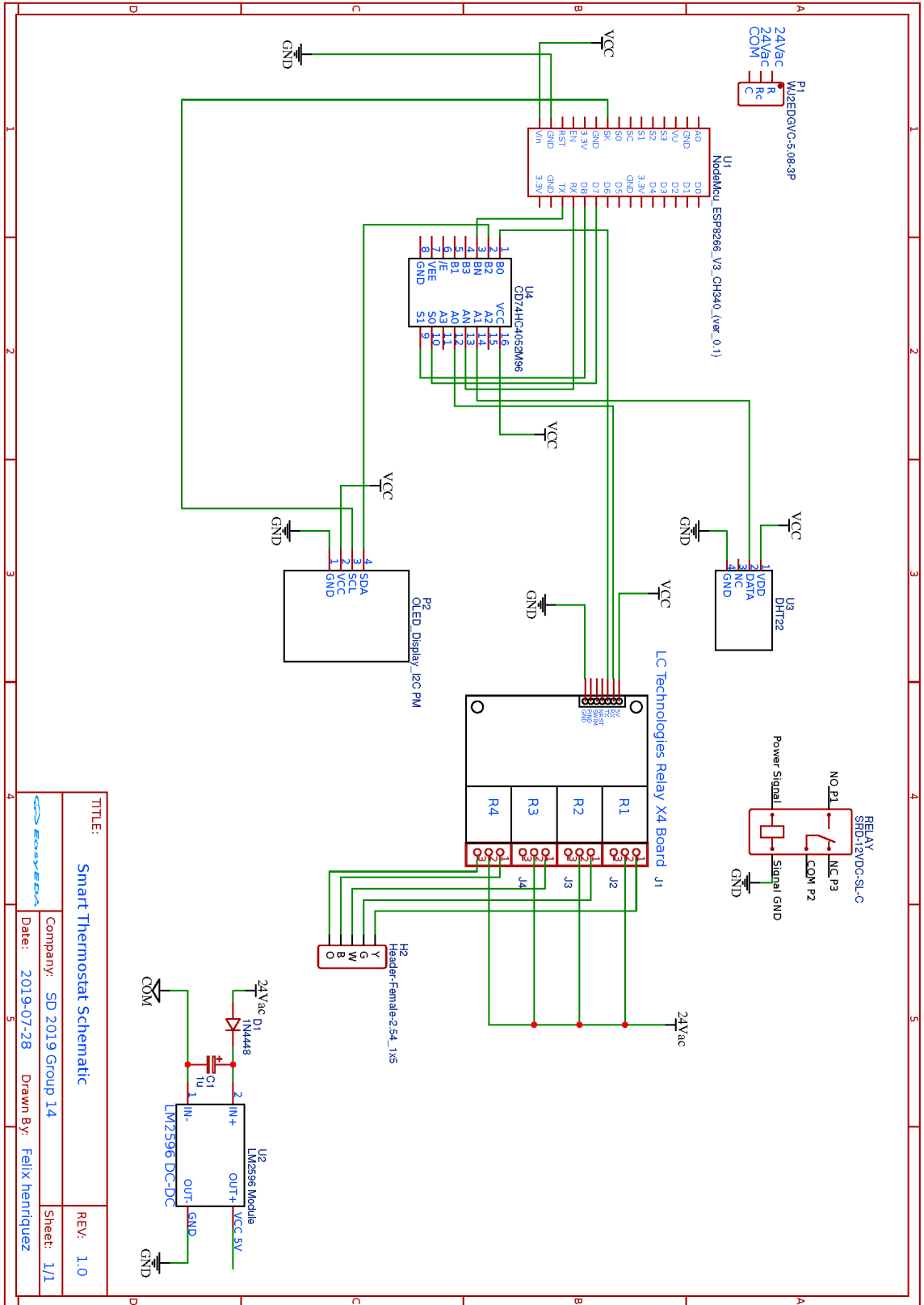

Figure 20. Smart Thermostat Schematic

The following table is our Bill of Manufacturing for the thermostat. The BOM represents most the components we will require to build this prototype. These costs are well below our target Price of \$50 despite many of the materials purchased here being bought at retail price. We are not getting the discount we would get when buying in bulk straight from the manufacturer. When we go in production the cost of injection molding our own exterior would be a minute fraction of that of the \$5 it will cost to prototype. We don't expect production costs to be greater than \$15. This should provide a very good profit margin for our product at \$50 retail, while still undercutting most of the competition, making this device our most profitable feature.

Table 10 Bill of Materials

Name	Designator	Footprint	Quantity	Manufacturer	Price
ESP8266 Relay Module	X4	Custom PCB	1	LC Technologies	\$ 5.50
NodeMcu ESP8266 V3 CH340 (Version 1.0)	U1	NEW PCB NODEMCUV3	1		\$ 2.14
LM2596 Module	U2	LM2596 DC-DC BUCK CONVERTER ADJUSTABLE POWER SUPPLY STEP DOWN MODULE	1		\$ 0.99
1N4448	D1	DO-35	1	SEMTECH	\$ 0.10
1u	C1	CAP-D3.0XF1.5	1		\$ 0.10
DHT22	U3	DHT22_AM2303_HORIZ	1		\$ 2.69
Header-Female-2.54_1x5	H2	HDR-5X1/2.54	1	BOOMELE	\$ 0.15
WJ2EDG VC-5.08-3P	P1	WJ2EDGVC-5.08-3P	1	ReliaPro	\$ 0.12
OLED_Display_I2C PM	P2	0.96 AND 1.3 I2C OLED SSD1306	1		\$ 1.76
CD74HC4052M96	U4	SOIC-16_150MIL	1	TI	\$ 0.25
Acrylic Housing	HO	NONE	1	Generic	\$ 5.00
				Total	\$18.80

The image below is a mockup of the final PCB layout with all components installed. The board will be enclosed in a hinged acrylic box that will measure around 130mm X 90mm. Board alone will measure 120mm X 80mm. This profile will meet our desired requirement of a housing smaller than 8"x6"x1" (Requirement 3.4). Material Costs for this should remain below \$20. The board will be completely enclosed except for the 8 female connector pins on the left side of the device that will receive the wires from a rear slot. The Terminals from top to bottom are R or Rc, Rh, C, Y, G, W, B, O or O/B.

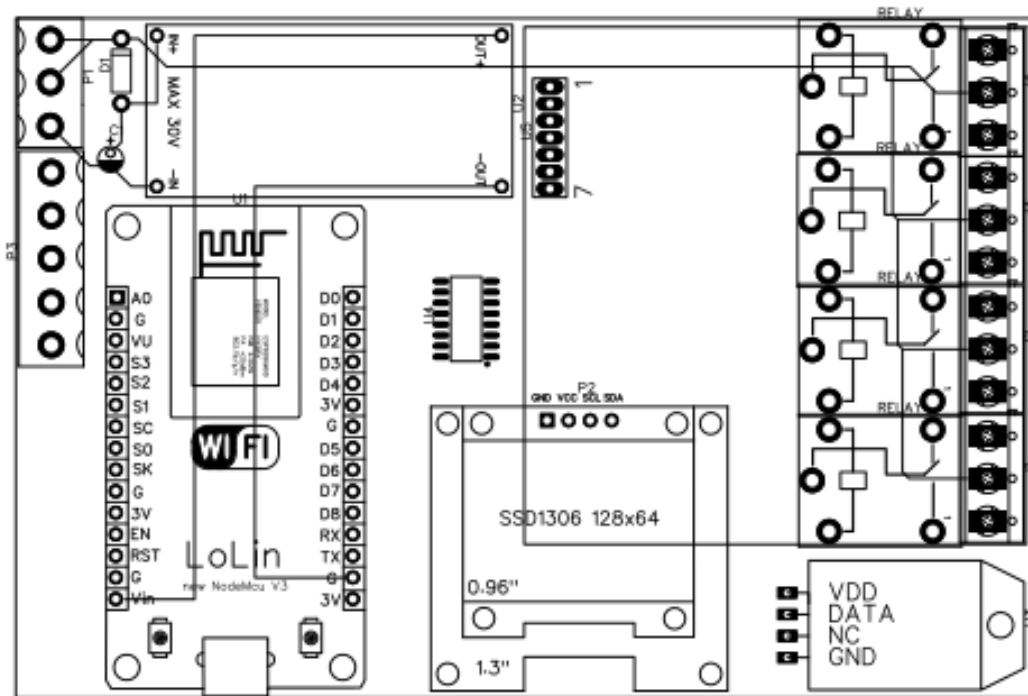

Figure 21. Smart Thermostat PCB Layout Mockup

5.1.2. SMART Outlet Design

For the SMART Outlet Design we will need to meet the following requirements:

- Ability to open and close and Outlet Circuit
- Support a maximum draw of 15A
- Fit inside an NEC Standard Electrical Box Housing
- Use 12 AWG wire for AC Circuits
- Have a working range of 30M

With the components we've picked out we believe we will meet or exceed these requirements. We will be using a 5V relay that can handle up to 20A at up to 220Vac. The HLK-PM01 PSU will be able to provide ample power to our DC components. The components will be small enough to fit in a PCB that will be placed behind the outlet. The CTB0158-2 terminals will support up to 12 AWG wires. Lastly the ESP8266 has a working range of 300m Line of Sight, so we should have no problem meeting the 30m range inside the home, this will have to be tested. These components will be similar to the once used in the AC thermostat but at a smaller scale. For this unit we will only require One Relay that

can support up to 220Vac at a maximum current draw of 20A. One terminal will receive the Hot input from the housing and power the circuit. A switching AC-DC power supply will ensure the circuit receives a steady 5Vcc supply. A voltage regulator may be necessary, we will determine this during testing. We will be using the same ESP8266 as all other wireless components. This microcontroller will use one GPIO pin to control the relay and another to receive input from the current sensor. We will be using a current sensor to determine when current is flowing to the Outlet this way the user will know when the Outlet is in use (see requirement 1.5) and the amount of power the device is using, allowing the user to track their energy consumption.

This design will be very similar to the Smart Switch, we start with the Line In (Hot Wire) connected to the PSU and the return to the Neutral Wire. The PSU will provide a constant +5VCC that will power the ESP01s and the ACS712 current sensor. To trigger the Relay, we require a 12V signal. We will need Isolate the Relay's trigger signal from the MCU. the LM2577 Step Up converter module will boost the +5VCC to +12V. This signal voltage will be stemmed by an optocoupler (4n35) that the MCU can trigger while remaining electrically isolated from the circuit with higher voltage. Since the ESP01s has a HIGH signal of 3.3V there needs to be a power limiting resistor at the optocoupler input since the max input voltage of the 4N35 1.3V. The Line In will be connected to the relay common terminal. The current sensor will measure the draw at the return line, so it will only measure current when the device is consuming power, this will not measure the current used by the system. The normally opened terminal will not be connected to anything. The system will operate normally closed so that the outlet will still function even if there is logic or system power failure. Having the 20A relay will ensure that if there is a current surge the outlet's breaker will trigger and the system will be protected. The logic will be simple, toggling the relay breaks or closes the circuit. For our first prototype both receptacles will dependent on one relay. In the future we may add another to control each receptacle individually.

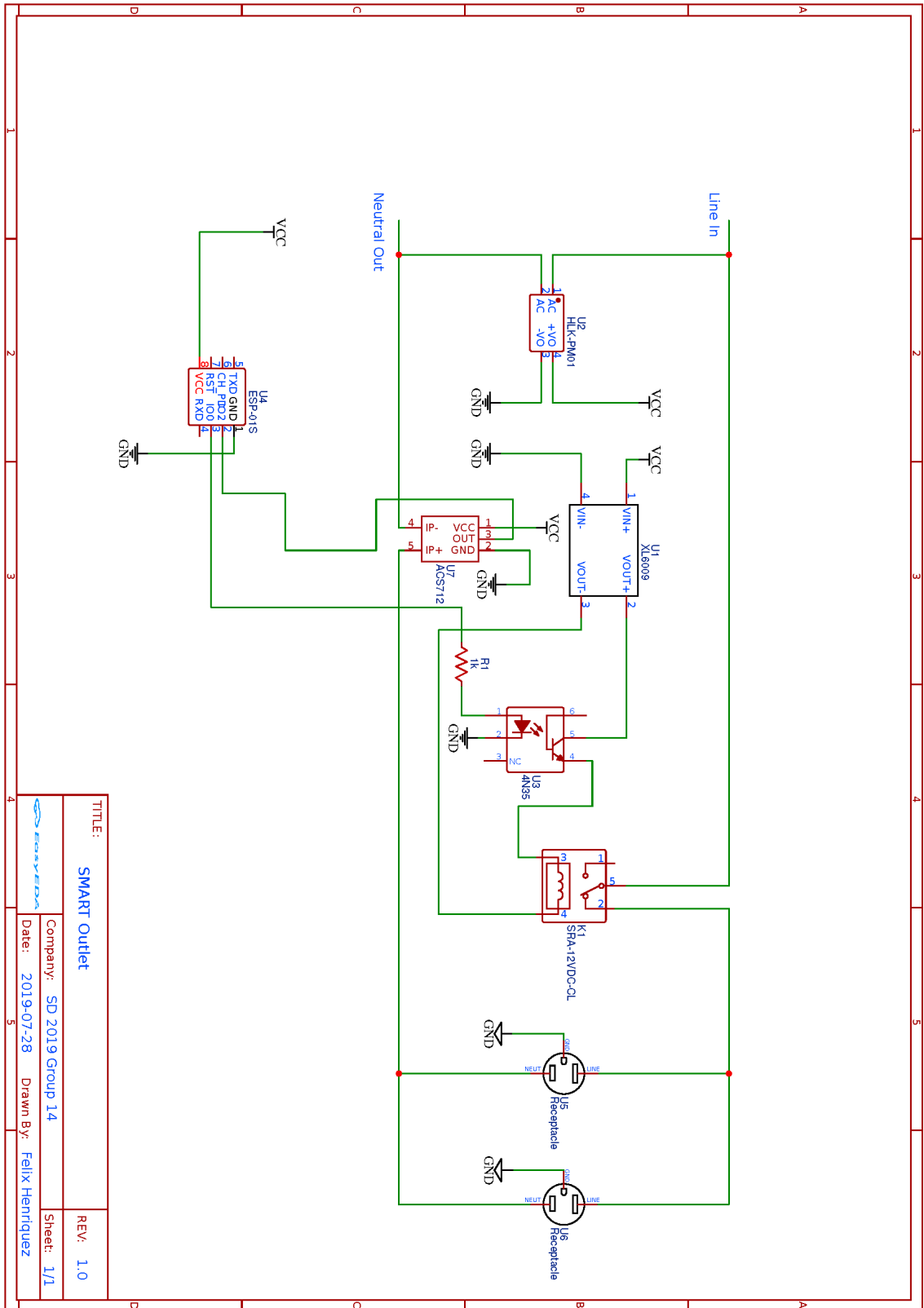

Figure 22. Smart Outlet Schematic

The following table is our Bill of Manufacturing for the outlet. The BOM represents all the components we will require to build this prototype. These costs are well below our target Price of \$20 even though many of the materials being purchased here are bought at retail price. We are not getting the discount we would get if we were ordering parts in bulk. Notice that nearly 50% of the cost to prototype is the housing and receptacle. When we go in production the cost of injection molding our own exterior would be a minute fraction of that, coupled with a bulk price on a standard receptacle, our manufacturing costs should be less than \$9. This should allow us a sizeable profit margin of at least 50% and meet our \$20 retail target.

Table 11 Bill of Manufacturing

Name	Designator	Footprint	Quantity	Manufacturer Part	Manufacturer	Price
XL6009	U1	XL6009	1	XL6009	LC Tech	\$ 1.60
HLK-PM01	U2	PWRM-TH_HLK-PM01	1	HLK-PM01	HI-LINK	\$ 2.50
4N35	U3	DIP-6	1	4N35	EVERLIGHT	\$ 0.10
SRA-12VDC-CL	K1	SRA-12VDC-CL	1	SRA-12VDC-CL	SONGLE	\$ 0.25
1k	R1	AXIAL-0.3	1	Generic	Generic	\$ 0.01
ACS712	U7	ACS712 MODULE REV01	1	ACS712	LC Tech	\$ 1.24
ESP-01S	U4	ESP-01S	1	ESP-01S	Ai-Thinker	\$ 1.22
40mm x 60mm PCB	PCB	PCB	2	Generic	Generic	\$ 0.44
Dual Receptacle	SW	None	1	Switch SPDT	Levington	\$ 1.60
Surface Mount Box	HS	None	1	Box Mount	Levington	\$ 5.99
Switch Frame	SF	None	1	Frame	Generic	\$ 1.00
Total						\$15.95

You'll find the PCB layout of the outlet in the next figure. All components will be laid out in a 120mm X 40mm board. This will fit snugly inside the mounting box right behind the

switch. There will be three labeled terminals behind the box for the Hot, Neutral, and Ground wires. The mockup also illustrates the layout of the tracks and connections that will be needed for the circuit. Not counted in the BOM but necessary during assembly will be the series of solder tracks and jumper wires that will make up these connections. When assembled, the device will be one compact unit with a 2” width, 4.9” height, and 3” depth.

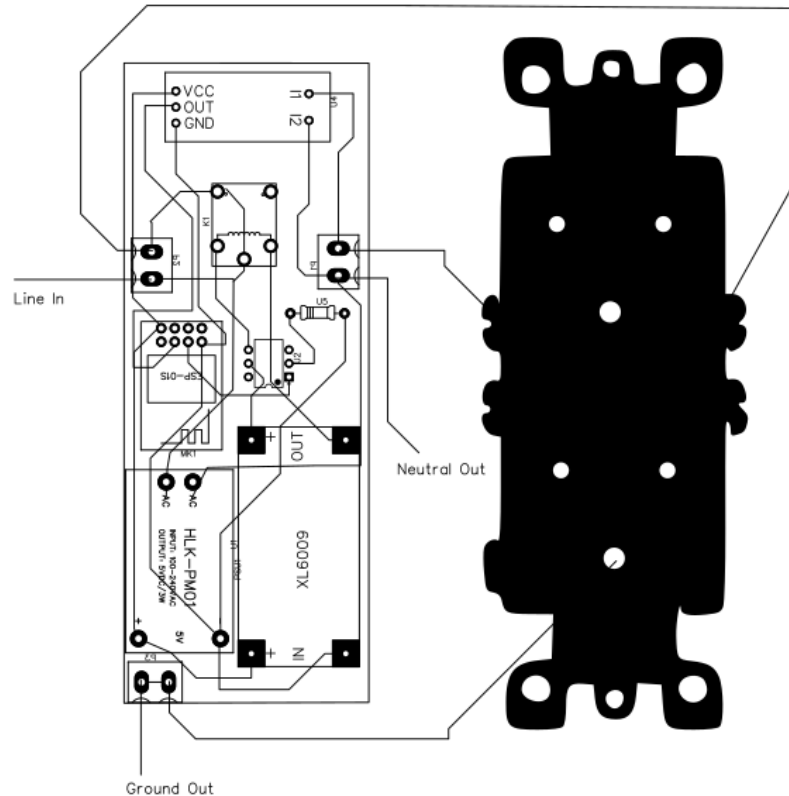

Figure 23. Smart Outlet PCB Layout Mockup

5.1.3. Light Switch Design

For the Light Switch Controller, we will have to meet these Requirements:

- Open/Close the circuit and turn ON/OFF whatever Light Fixture or appliance is wired
- Allow for the switch to remain operational regardless of Relay position.
- Support a maximum load of 15 amps at 110-220Vac
- Fit in an NEC Standard Electrical Box Fixture
- Support 12 AWG wires
- Have a Minimum working range of 30m

The same components as the Outlet Unit should meet our requirements for the light switch. We will be using the same 5V relay that can handle up 20A at up to 220Vac. The HLK-PM01 PSU will be able to provide the power to our DC components. The components will be small enough to fit in a PCB that will be placed besides the actual switch inside of a custom housing. The CTB0158-2 terminals will support up to 12 AWG wires. Lastly the ESP8266 has a working range of 300m Line of Sight, as stated previously this will have to

be verified during testing. There is one caveat with this unit and that is, unlike the Outlet, we cannot take full control of the system. The user must be able to manually flip the switch to turn the system on and off. This must also not create an open circuit within the system that will turn off the MCU. To achieve this deliverable then we must use a 3-way switch and a 3-way circuit between the switch and the controller.

Our design begins with the Line In (Hot Wire) connected to the PSU and the return to the Neutral Wire. The PSU will provide a constant +5VCC that will power the ESP01s and the ACS712 current sensor. To trigger the Relay, we require a 12V signal. Our MCU cannot provide 12 volts, it can't even tolerate it, so we will need to provide isolation from the Relay's trigger signal, the LM2577 Step Up converter module will boost the +5VCC to +12V. This signal voltage will be stemmed by an optocoupler (4n35) that the MCU can trigger while remaining electrically isolated from the circuit with higher voltage. Since the ESP01s has a HIGH signal of 3.3V there needs to be a power limiting resistor at the optocoupler input since the max voltage the 4N35 can withstand is 1.3V at the input. The Line In will be connected to the relay common terminal. The current sensor will measure the draw going into the terminal. The NC and NO terminals will be wired with travelers to the SPDT Paddle Switch. The ground wire from the switch will connect to the ground terminal of the board. We can describe the system's logic using this table:

Table 12 Switch System State Machine

Relay State	Switch State	Light Bulb
Closed	On	On
Open	On	Off
Closed	Off	Off
Open	Off	On

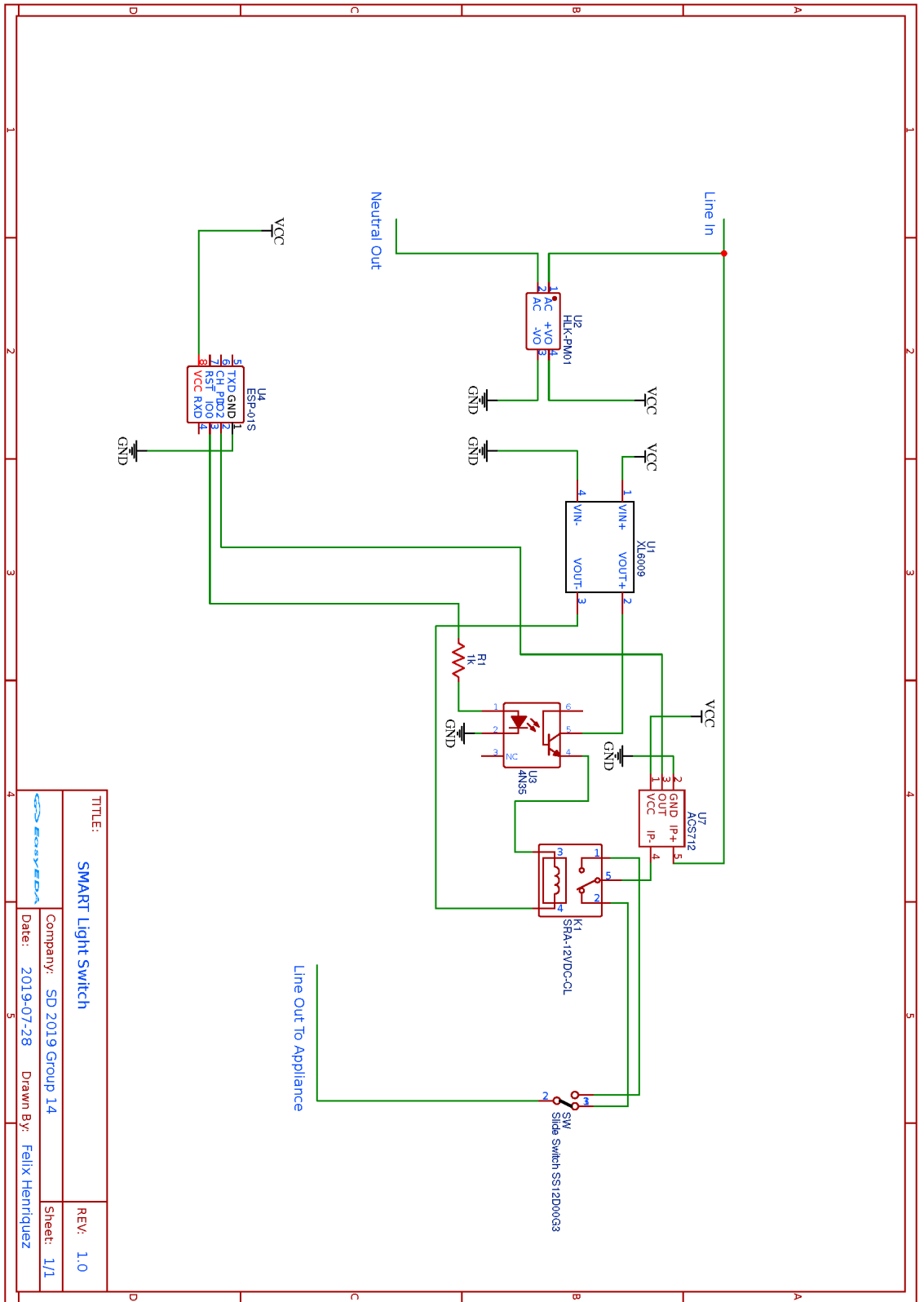

Figure 24. Smart Light Switch Schematic

Below, you will find our Bill of Manufacturing. These costs may be over our target Price of \$15 but keep in mind that many of the materials being purchased here are bought at retail price. We are not getting the discount we would get if we were ordering parts in bulk. Notice that nearly 60% of the cost to prototype is the housing and switch. When we go in production the cost of injection molding our own exterior would be a minute fraction of that, coupled with a bulk price on a standard paddle switch, our manufacturing costs should be less than \$9. This should allow us a sizeable profit margin and meet our \$15 retail target.

Table 13 Bill of Manufacturing

Name	Designator	Footprint	Quant .	Manufacturer Part	Manufacturer	Price
XL6009	U1	XL6009	1	XL6009	LC Technologies	\$ 1.60
HLK-PM01	U2	PWRM-TH_HLK-PM01	1	HLK-PM01	HI-LINK	\$ 2.50
4N35	U3	DIP-6	1	4N35	EVERLIGHT	\$ 0.10
SRA-12VDC-CL	K1	SRA-12VDC-CL	1	SRA-12VDC-CL	SONGLE	\$ 0.25
1k Resistor	R1	AXIAL-0.3	1	Generic	Generic	\$ 0.01
ACS712	U7	ACS712 MODULE REV01	1	ACS712	LC Technologies	\$ 1.24
ESP01S	U4	ESP-01S	1	ESP-01S	Ai-Thinker	\$ 1.22
40mm x 60mm PCB	PCB	PCB	2	Generic	Generic	\$ 0.44
3-Way Paddle Switch	SW	None	1	Switch SPDT	Levington	\$ 5.82
Surface Mount Box	HS	None	1	Box Mount	Levington	\$ 5.99
Switch Frame	SF	None	1	Frame	Generic	\$ 1.00
					Total	\$20.17

The next image shows the PCB layout of the switch. All components will be laid out in a 120mm X 40mm board. This will fit snugly inside the mounting box right behind the switch. There will be three labeled terminals behind the box for the Hot, Neutral, and Ground wires. The mockup also illustrates the layout of the tracks and connections that will be needed for the circuit. Not counted in the BOM but necessary during assembly will

be the series of solder tracks and jumper wires that will make up these connections. When assembled, the device will be one compact unit with a 2” width, 4.9” height, and 3” depth.

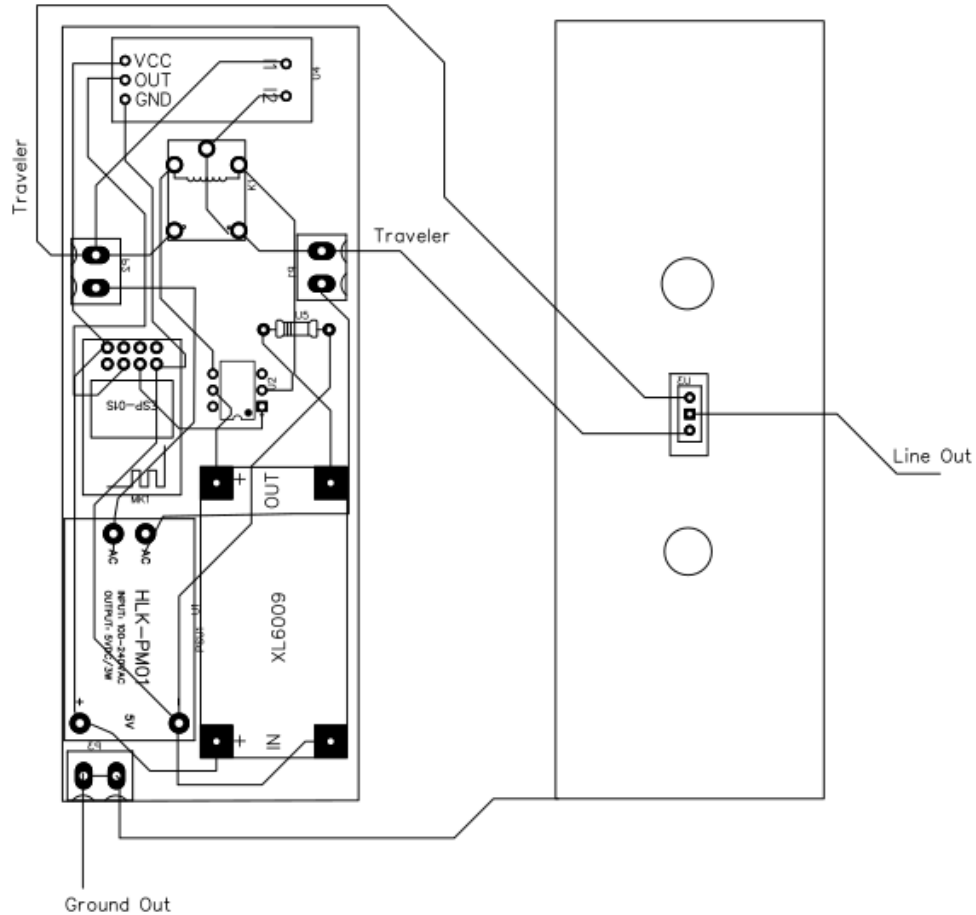

Figure 25. Smart Switch PCB Mock Layout

5.1.4. Fire Detector Housing

Our fire detection modules will be mounted in a container with the following specifications:

- Aluminum interior
- 1-inch diameter holder for lens
- Detachable backboard
- Holes for wiring and attaching sensor via screw

The aluminum interior will provide the incident rays with a reflective medium to allow more light to be reflected onto the sensors. The lens holder portion will consist of two extruded concentric cylinders one atop the other with the larger circle around 1.1 inches and the lower circle around 0.9 inches to allow the lens to easily fit within the mount. The backplate will be mounted to the central housing through four screws located on each of the corners. Figure 26 shows a simple design for the sensor housing with the lens holder and base plate which was made using TinkerCAD. These are the initial designs for the sensor housing unit and further improvements will be in removing the inside edges and

extruding the edges of the baseplate and housing to allow for usage of screws. Table 14 and table 15 show the dimensions and the positions of the sensor housing and the baseplate.

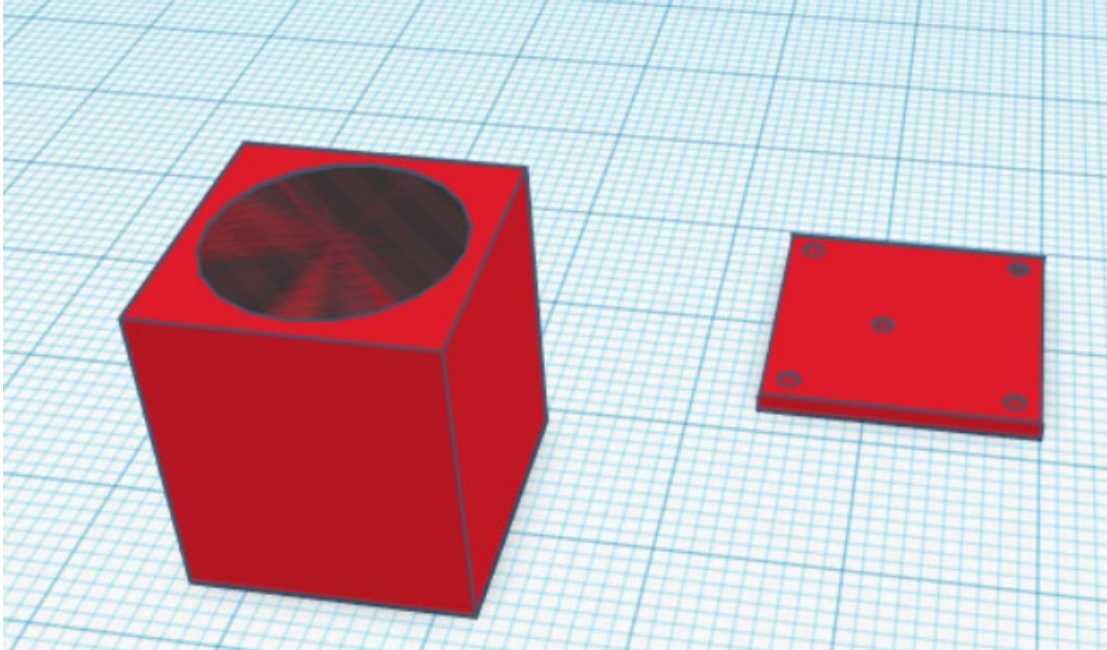

Figure 26. Sensor Housing with Lens Holder and Baseplate

Table 14 Sensor Housing Dimensions and Positions

Shape	Purpose	Height	Length	Width
Box	Main Housing	1.5"	2"	2"
Box Hole	Enclosure for Photodiode	1.1"	1.8"	1.8"
Cylinder Hole	Opening for Lens Placement	0.15"	1.1"	1.1"
Cylinder Hole	Opening for Lens Placement	0.15"	0.9"	0.9"
Threaded Cylinder Hole	Fastening Baseplate	0.125"	0.05"	0.05"
Threaded Cylinder Hole	Fastening Baseplate	0.125"	0.05"	0.05"
Threaded Cylinder Hole	Fastening Baseplate	0.125"	0.05"	0.05"
Threaded Cylinder Hole	Fastening Baseplate	0.125"	0.05"	0.05"
Box Hole	Opening for Wiring	0.1"	0.1"	0.2"

Table 15 Baseplate Dimensions and Positions

Shape	Purpose	Height	Length	Width
Box	Main Baseplate	0.1"	1"	1"
Threaded Cylinder Hole	Fastening Screws	0.1"	0.05"	0.05"
Threaded Cylinder Hole	Fastening Screws	0.1"	0.05"	0.05"
Threaded Cylinder Hole	Fastening Screws	0.1"	0.05"	0.05"
Threaded Cylinder Hole	Fastening Screws	0.1"	0.05"	0.05"
Cylinder Hole	Mounting Photodiode onto the Baseplate	0.1"	0.05"	0.05"

The next table is our BOM for this product. This is our most accurate estimate of parts costs. Pricing for this item has not been determined yet but as we get more information on the cost of producing the housing and lenses we are confident that the pricing should not go higher than this.

Table 16 Bill of Manufacturing

Name	Footprint	Quantity	Manufacturer Part	Manufacturer	Price
9 Volt Battery	BH9VW	1	No.7	ReliaPro	\$1.00
LM2596	STEP_DOWN LM2596S	2	LM2596	LC Technologies	\$1.40
FLAME-DETECTOR	FLAME-DETECTOR	1	LM393	LC Technologies	\$0.50
ESP01S	ESP01S	1	ESP8266-01s	Zuc Zuc	\$1.67
Battery Connector	N/A	1		Generic	\$0.25
Housing	N/A	1		3D Print	\$5.00
Lens	N/A	1			\$10.00
					19.82

Flame Detector Circuit Design Details

You will find our circuit schematic for the flame detector in the next page. The design will consist of 5 major components, the Battery, Voltage Regulators, the ESP-01s, and the sensor. The system will require 2 voltage converters because the sensor operates with 5 volts and the MCU requires 3.3V supply.

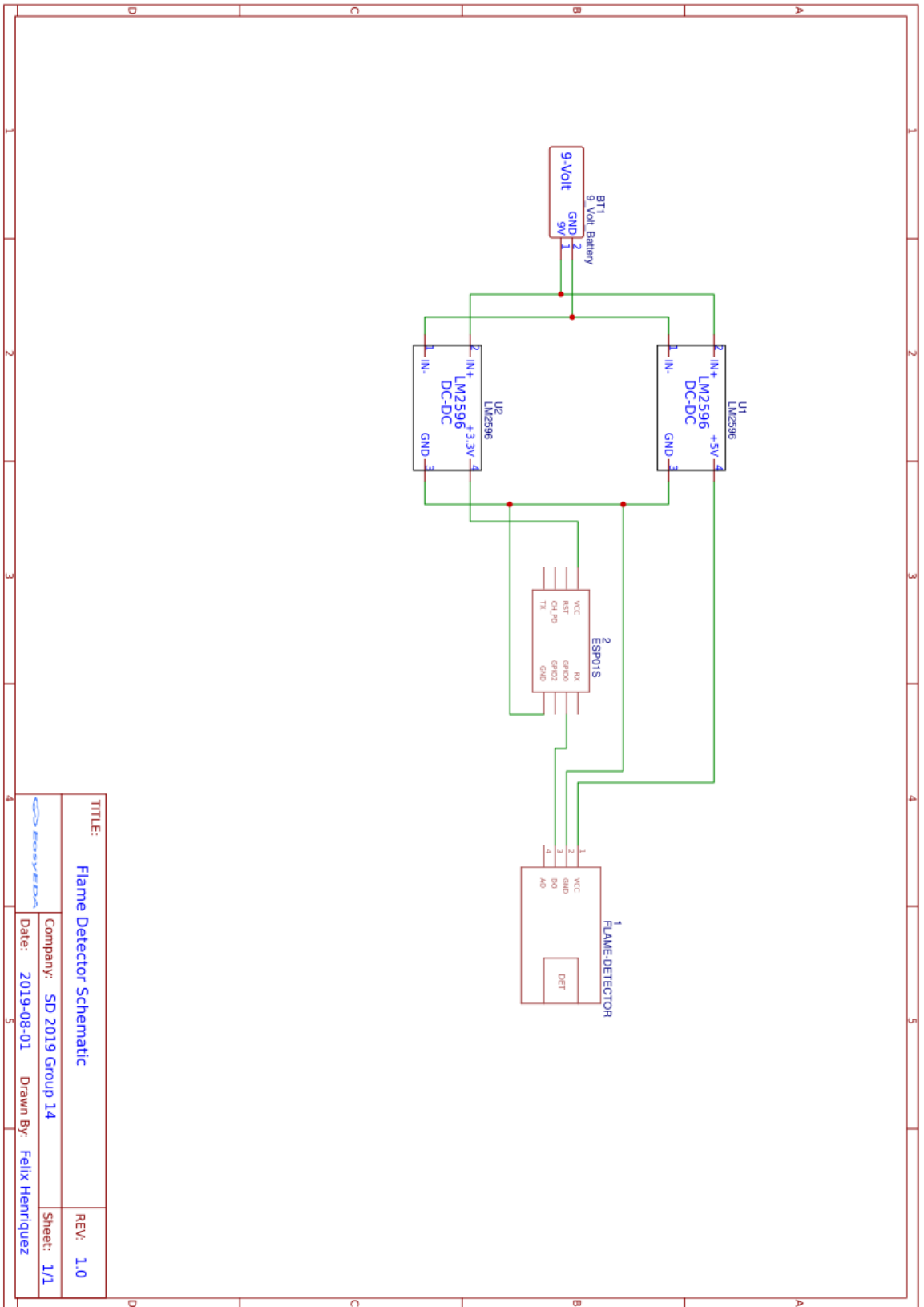

Figure 27. Flame Detector Schematic

The Following image is our PCB mockup for this sensor. The image illustrates the likely connections and dimensions of the board. The layout of the components are subject to change as the enclosure design is finalized.

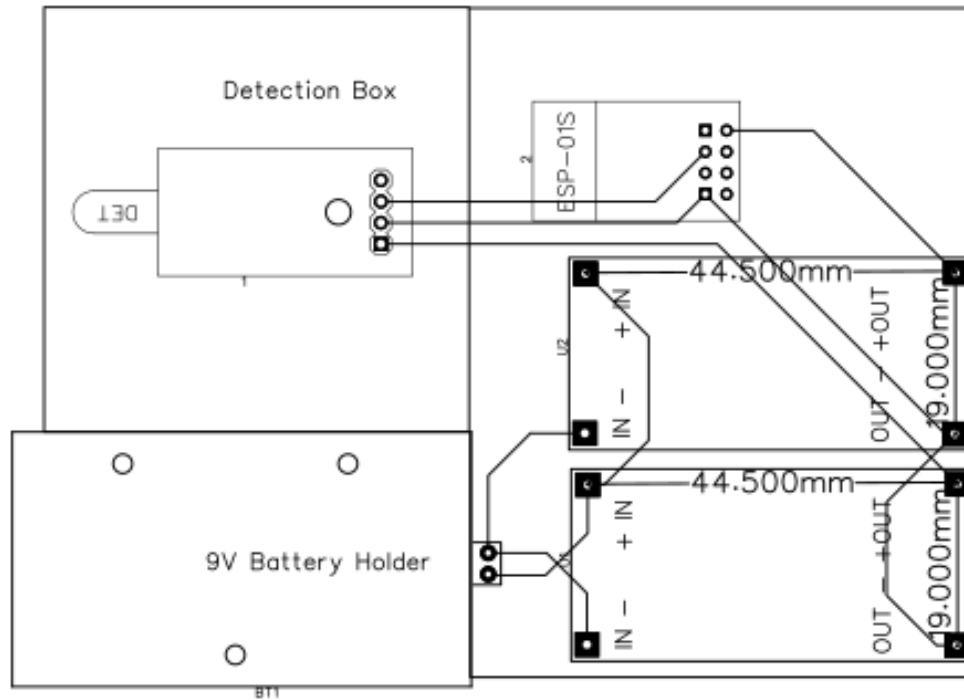

Figure 28. Fire Detector PCB Mockup

5.2. Software Design Details

5.2.1. Microcontroller Components Software

The Following diagram displays the general function of our system. In this section we will define the software necessary for features like the Smart Switch, Outlet, Flame Detector, and Motion Detector to have the desired functionality and to be able to communicate with the system HUB. Illustrated in the diagram is the various input and output channels of the system. The switch will have to make TCP responses to the hub as well as control the connected appliance. Same goes for the outlet. The flame and motion detectors will not require inputs from the system. Their task will simply be to upload sensor data at various intervals. This will be set up using interrupts to make sure those products have minimum energy consumption since they will be battery powered

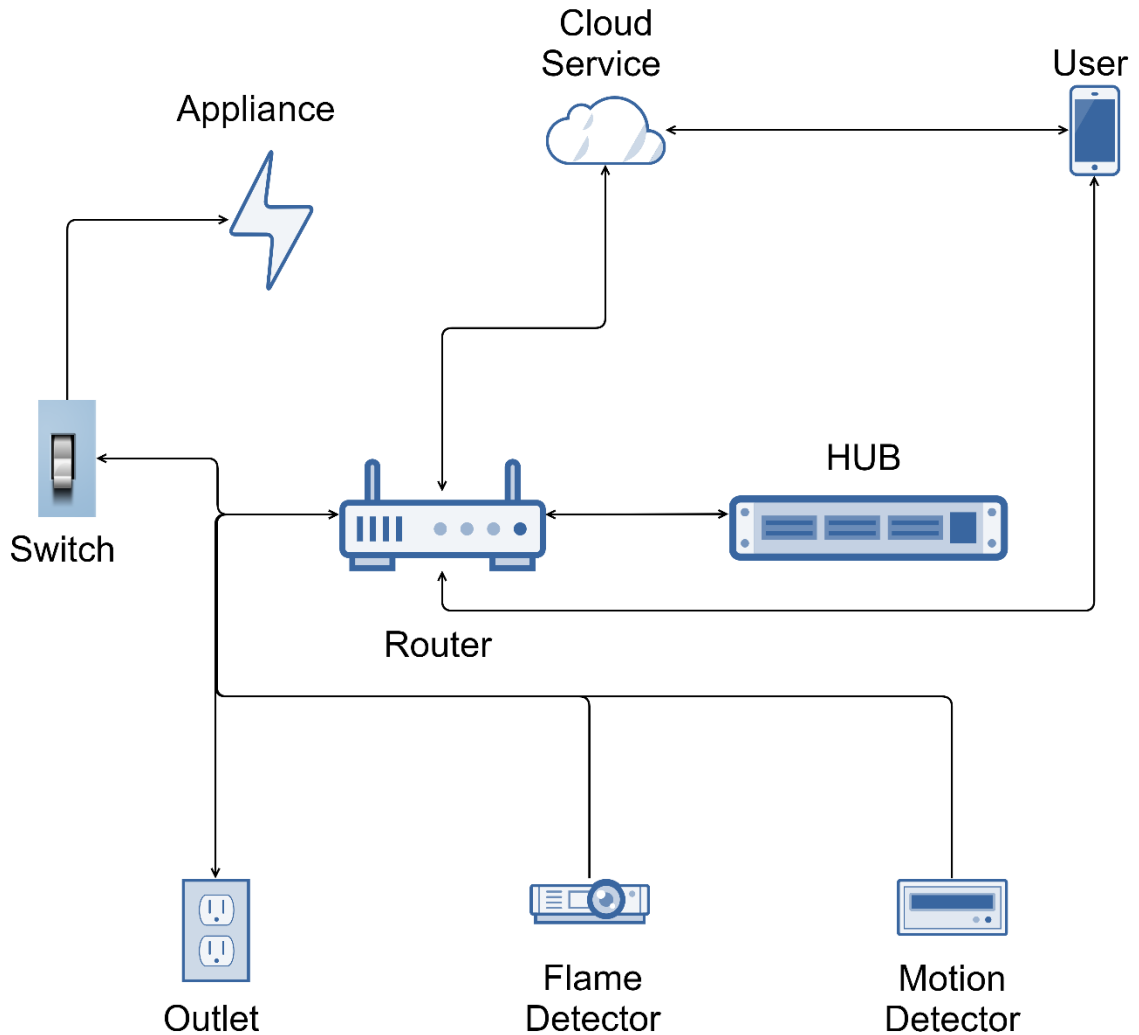

Figure 29. Function Diagram

The next figure will be our software process. To provide a seamless set up will we be using the WPS connection of modern routers to connect our devices to the local area network. When first powering up the devices will be on stand-by mode awaiting their WPS button to be pushed, starting the process of connecting to the router who's WPS button was also pushed. It is recommended that the router's button be pushed first so that it is in search mode when the device's button is pushed. The device will attempt to connect to the router for some period. If no connection occurs the device will return to stand-by mode. If connected, the device will multicast an encrypted "Available" message until the HUB responds with a link request. The device will send out its local IP and the HUB will register the device to the system. Configuring the device will be left up to the user, through the Web UI. For these four devices the command loop will be generally the same. They will either send back sensor data when those interrupts are triggered, or they will respond to commands when the HUB sends requests. Though all 4 devices will share hardware, the sensors will have a flag that block any commands. We only want these sensors to send back data. The HUB will have to interpret and create the logic for using the data.

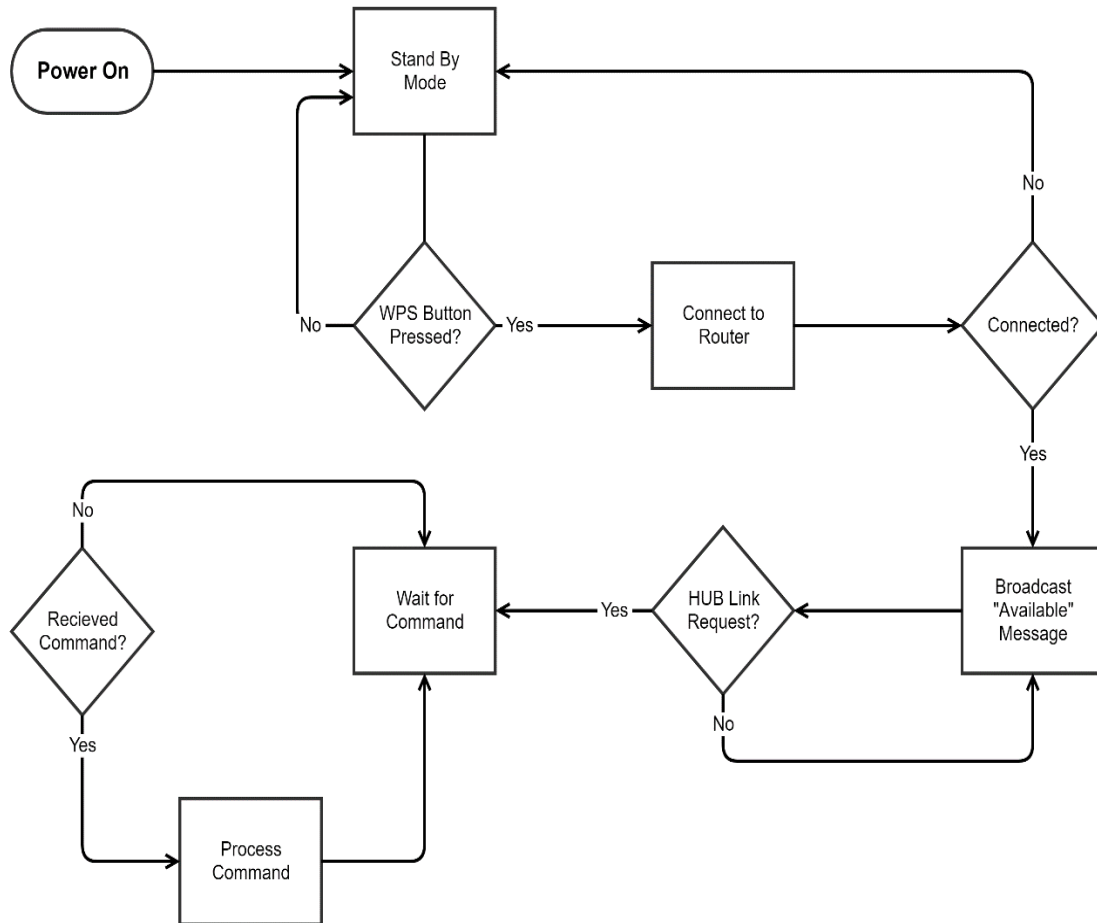

Figure 30. Software Process

We will be using the Arduino IDE to flash all the MCUs. This IDE uses C++ scripts so we will make have a class structure for our code. We will generally have 4 classes:

- **WPSConnect:** Responsible for connecting to router after push button interrupt.
- **HUBLink:** Responible for handling the link between the device and HUB once a LAN connection has been established
- **CommandLoop:** Main loop. Will handle the functionality of the device. Devices not wired to an external power source will use interrupts for their logic so they can remain in low power mode.
- **Interrupts:** Class that will handle all interrupt logic.

Three of the classes will share the same connection object. The following class diagram will prototype our code structure. Not all member variables are defined. We will have to go through the ESP8266 library to see what kind of built in functionality is available. There needs to be a consorted effort to use as much of the built-in functionality from the IDE and the MCU libraries. Arduino provides a board manager that handles most of the embedded code. PIN mapping and setting registers can be an arduous task and should be avoided.

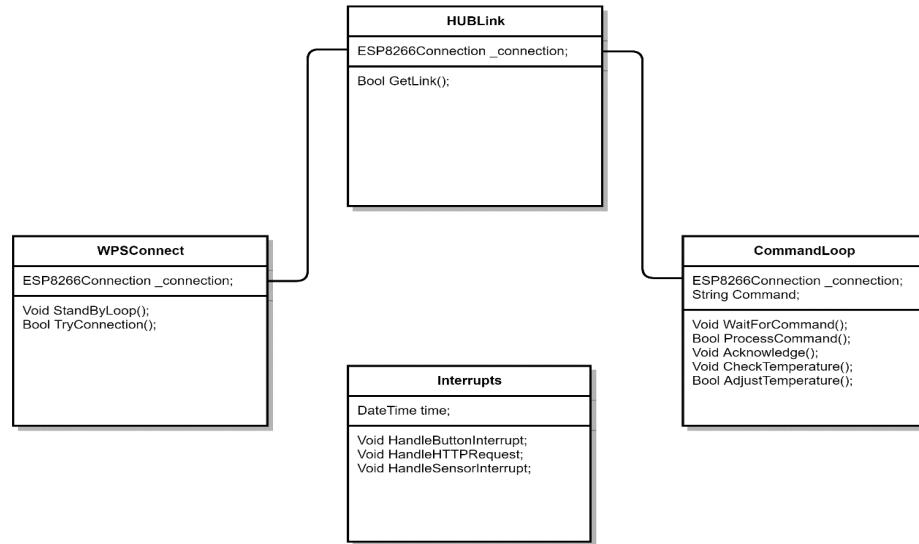

Figure 31. System Class Diagram

The thermostat’s software will be unique in the sense that it will be the only device to have logic built into the embedded system. The thermostat must take inputs from its temperature and humidity sensor as well as from the HUB and button interface and define the logic of when to turn on and off the cool air or heat. For that reason, we will be using the NodeMCU module for the brain. It’s a more robust MCU with more memory than the ESP01 so it will handle the larger code. The system diagram below shows that the functionality will remain relatively the same as the other devices.

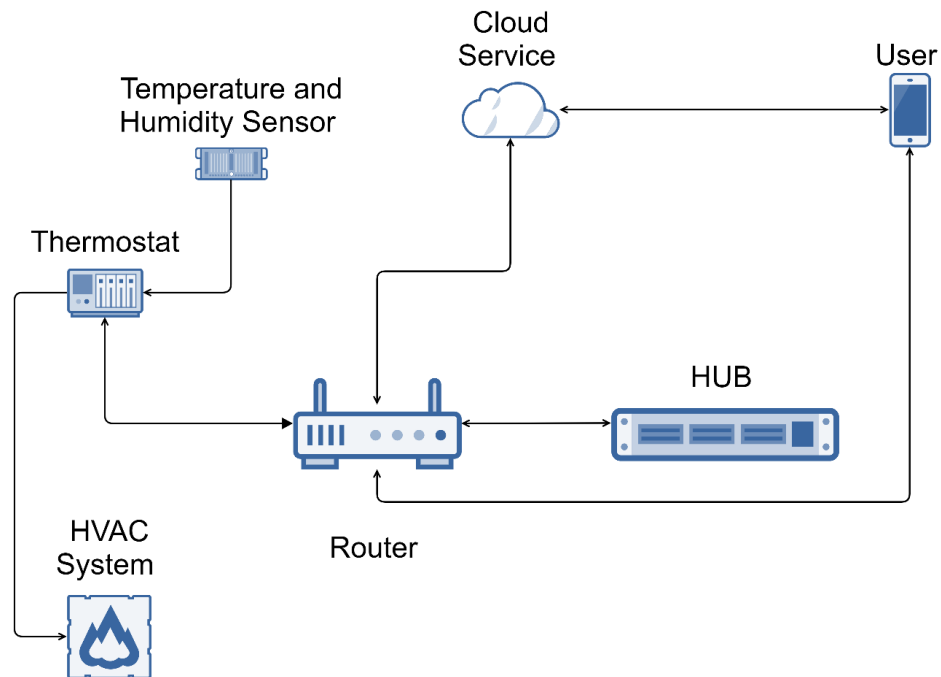

Figure 32. System Diagram

The startup process, shown in the following flowchart, will begin like the four other devices with one difference, during the command loop the thermostat will have to adjust for temperature changes and schedule changes since we have defined a requirement that a schedule can be set. The thermostat will also need to be able to respond on command to setting changes done by either HUB requests or push-button interrupts when the user sets a new target temperature manually. The technical details for achieving this logic will be decided during the second phase of this project

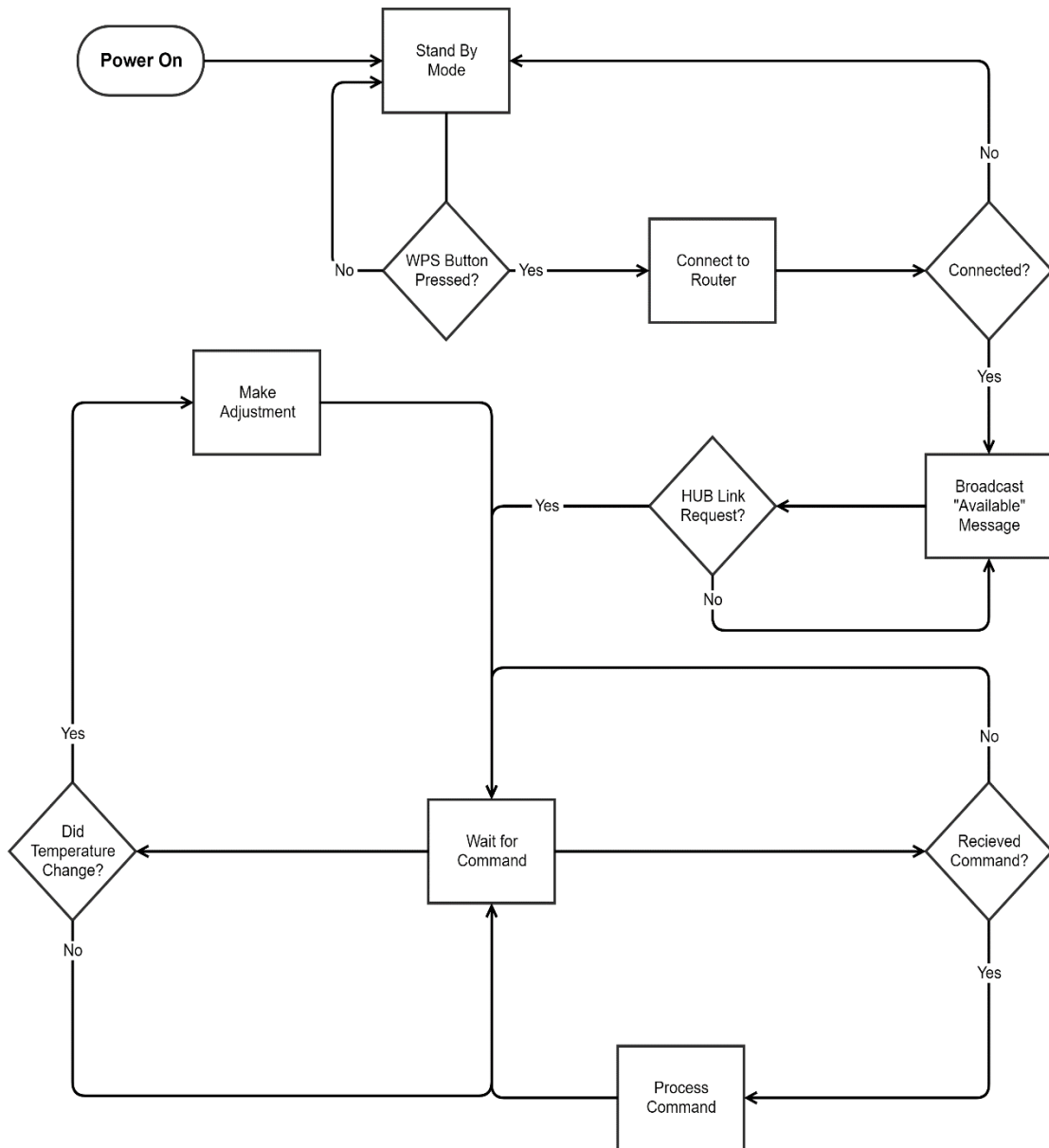

Figure 33. Thermostat System Flowchart

5.2.2. Considerations for Network Connection Between Hub and LAN

Ethernet Connection

There are several benefits to making use of a direct wired Ethernet connection when it comes to means by which the hub might be connected to the user's LAN. When it comes to considerations of latency, reliability, and bandwidth, it's difficult to beat a cable connection, as wired connections are not beholden to considerations of wireless interference or signal degradation due to walls or other structures. However, convenience is lost when choosing this option, especially if the user wishes to install the device in an area of the home which is a large distance from the location of the user's router or network hub. Because we do not expect the bandwidth usage of the device to be particularly high, the gains in latency and transfer rate are not of great enough value to the project to make this the sole means of connecting the hub to the local network. However, because the Raspberry Pi 3 does possess an Ethernet port, it would not be detrimental to provide Ethernet as an optional means of connecting the device to the local network.

Wi-Fi (WPA2 PSK)

WPA2 using a pre-shared key is one of the most common means of securely providing access to a home-based local-area-network currently in use and is generally considered to be adequate for personal security, due to the low number of individuals expected to see and make use of the pre-shared key in such an environment. In the case of an organization-level wifi deployment, PSK is often undesirable due to the risk of a singular employee or other authenticated individual sharing the key with a third-party, causing said organizations to more often opt for WiFi-PEAP, as it provides individualized authentication which may be easily revoked or traced to an individual in the event of a breach. Though the pre-shared key is used for initial authentication between the network and the client, in order to limit the exposure of this master key, a four-way handshake takes place during authentication in which a pairwise-transient key is computed which is then used to encrypt messages for the remainder of the session.

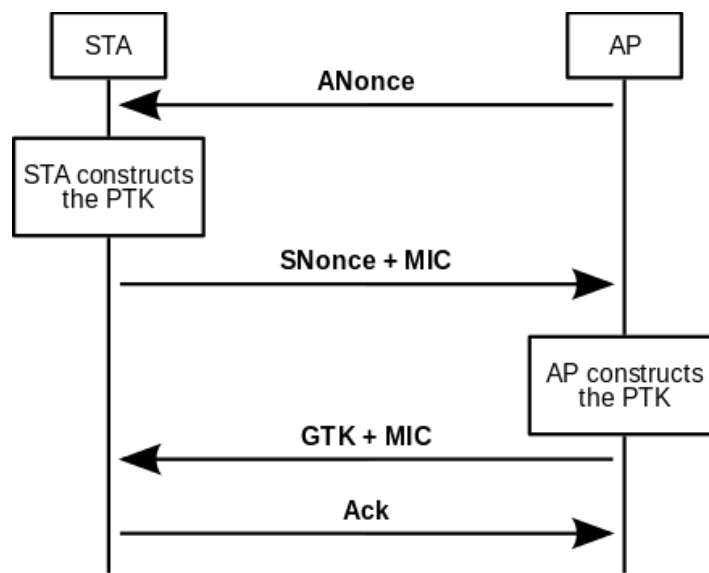

Figure 34. Diagram of four-part WPA2 Handshake

One issue with using pre-shared key-based authentication lies in the fact that we currently plan for the hub device to be completely headless, requiring no display or input peripherals to make use of due to the online interface. However, WPA2-PSK based authentication presents a catch-22 in this case. If the user is to gain access to the device via the web interface, it must first acquire an internet connection, but since the device is meant to have no input peripherals, this means that there would be no reliable way for the user to input the pre-shared key specific to their network in order to allow the device to acquire a connection.

Wi-Fi WPS (WiFi-Protected Setup)

One system which might help to sidestep the issues with authentication is WiFi-Protected setup (WPS). This protocol is designed to provide a ‘push-button authentication’ which allows a single device to connect to and authenticate with the wireless network for a short time following the activation of a special mode on the router via the push of a button. This would solve the above issue, as there would be no need for any means of providing the hub device with a pre-shared key for the wireless network. Once the device has been paired once, need for further authentication would also be eliminated.

However, this method does carry several security issues [9]. Firstly, due to flaws in the means by which WPS PINs are rejected, WPS-based security can be brute-forced, with the time required to brute force being manufacturer-specific and largely dependent on whether said manufacturer has implemented timed lockouts following an excessive number of failed attempts.

Another significant vulnerability, the severity of which depends on the specific implementation, lies in the fact that some routers have been reported to calculate their WPS PIN numbers from the hardware MAC address of the router itself. This is troubling because, in such cases, a brute force attack is not even required to break the network’s security, as once the process for computing the PIN is known, it can simply be computed via the same process client-side and then sent to the router for access.

Finally, if the WPS-enabled router is not kept in an area which is *physically* secure, there is a risk of someone with physical access to the device, but who is not meant to be making use of the network, making use of the authentication push-button to achieve authentication with the network. For our use case, this security concern is of little severity when compared to the two above, as such a compromise in security would mean that the intruder already has access to the interior of the user’s home anyways.

Still, given the desire to reduce the cost and complexity of the system by avoiding the need for user I/O peripherals on the hub makes WPS an attractive option than Ethernet or pure WPA2-PSK based authentication. Thus, we plan to offer it as an option for configuration if the user wishes to make use of it regardless of the risks, and offer Ethernet based connection as the more secure method of installation. If WPS proves not to be viable, because the security concerns are too great or otherwise, it is more likely that we will fall back to using a wired ethernet connection than it is that we will add an interface for entering a pre-shared key, as the latter case would be a significant departure from the current hardware design outlined in the project and would act to significantly increase the cost of the device.



Figure 35. Example of a typical router WPS authentication button

5.2.3. Networking Overview

To allow the user access to in-house systems from anywhere with an internet connection, it was decided that a web server would act as a go-between between the user's device and the system hub. This webserver will provide an HTTP-Based interface to the smart home hub, carry out authentication and access-control tasks by maintaining a user login database which associates users with their specific home devices. The hub will communicate with the server and both receive configuration information and user-commands and will likewise send information regarding the current status of sensors and devices within the home to the server, so that this information may then be relayed to the client via the user interface. The system will use UPnP to allow for the server to carry out the necessary network-address-translation between the open internet and the device on the user's LAN. An authentication system will be implemented between the server and the hub to ensure that the hub cannot be accessed without access to the proper user account.

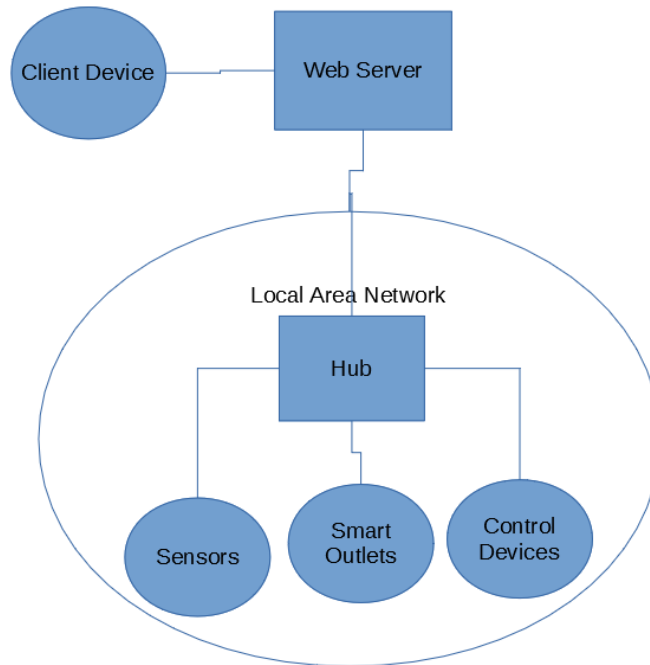

Figure 36. Network Diagram

If UPnP is not available on the user's hardware, the system will fall back to an asynchronous scheme where the web server is checked at regular intervals for updates to the user's preferences and to transmit information regarding the state of the smart-home system to the web-server.

The other option for networking is to make the communication between the hub and the server completely webservice-based, which bears numerous advantages. This would get around the issue of network address translation completely by allowing the hub to simply check in and maintain a regular connection with the server. There are also a wide variety of well-supported webservice types such as SOAP, AJAX, etc. Webservices are also helpful in the sense that they make it simpler to transmit and sort through well-formatted data, and oftentimes involve transmission done in XML or other forms of markup-language. Whereas raw internet-based data transmission methods (websockets, etc) would require that data be sent in a stream of one sort or another and sorted out later, a webservice-based solution will allow for all requested or sent data to be easily organized in a markup, from which relevant information can be isolated as required.

The only potential drawback of such a system is that it would require that the hub maintain a consistent connection to the server in order to ensure that commands from the user can be received in a timely manner, which has the potential to increase power usage. All the same, considering the fact that out of all the devices on the network, the hub is the least likely to be connected to battery-power, it seems to be an acceptable choice as the increase in power consumption would be negligible for a wall-outlet powered device and will not have a significant impact on the performance of any battery-operated devices which *are* connected to the smart home system.

5.2.4. Device Discovery

The hub device will be responsible for facilitating discovery and connection with other devices on the network. Presuming an option by which the hub and the smart-home devices which it controls are both connected directly to the user's LAN, there are numerous ways which device discovery may be achieved, but many are either slow or require extra configuration that would prove cumbersome to the end-user. To that end, we have opted to avoid a setup where smart home devices which make up the system connect to the user's wifi, instead connecting directly to the hub via a peer-to-peer direct connection. However, the methodologies considered for device discovery on the network are listed below, and the most enticing was chosen to be most useful for an in-home application on a relatively small LAN with a single subnet, and to minimize extra work and configuration required from the user. The options considered are outlined below:

ICMP ECHO request (Ping) scan

The primary benefit to this technique is its simplicity and reliability, as it is supported by practically every device that would be deployed on a private LAN and is a rock solid, ubiquitous part of the networking infrastructure. However, there are significant downsides to this option, the most important being that it is slow. A full scan of a 255-address network space can take upwards of ten seconds and following the discovery of a list of devices connected to the network, those devices which are configured to be workable components of the smart-home system must then also be differentiated from other, unrelated devices on the network through other means. For these reasons, this is not an ideal method for discovering devices within the network for our purposes.

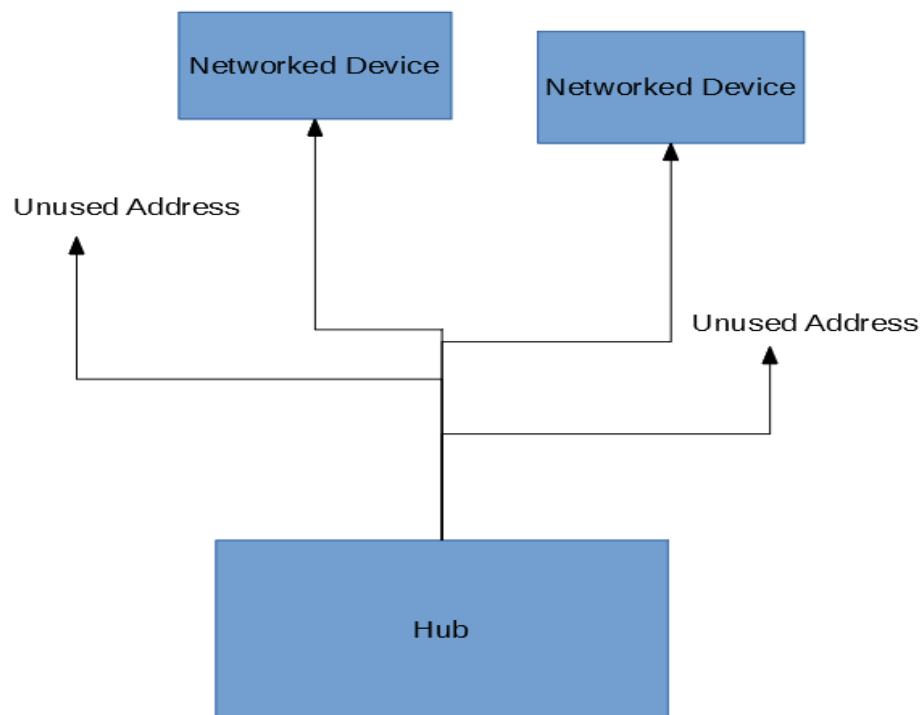

Figure 37. Ping Scan outline, with arrows representing ICMP ECHO requests

DNS-Based Discovery (DNS-SD)

With this technique, a local DNS server would be configured to route traffic bound for a predetermined domain-name to the internal address associated with that service, in this case the smart home hub. This technique had significant benefits in terms of speed and network resource usage and is similar in structure to how a client would access a server over the internet via a standard URL address. This makes it ideal for businesses and large-scale internal networks which wish to provide a service to a large number of clients within the network. Although this technique has its advantages in terms of efficiency, the need for extra software and potentially hardware to sit on the network and carry out the requisite name-resolution tasks make it somewhat undesirable for use in a system designed to be installed in a home environment.

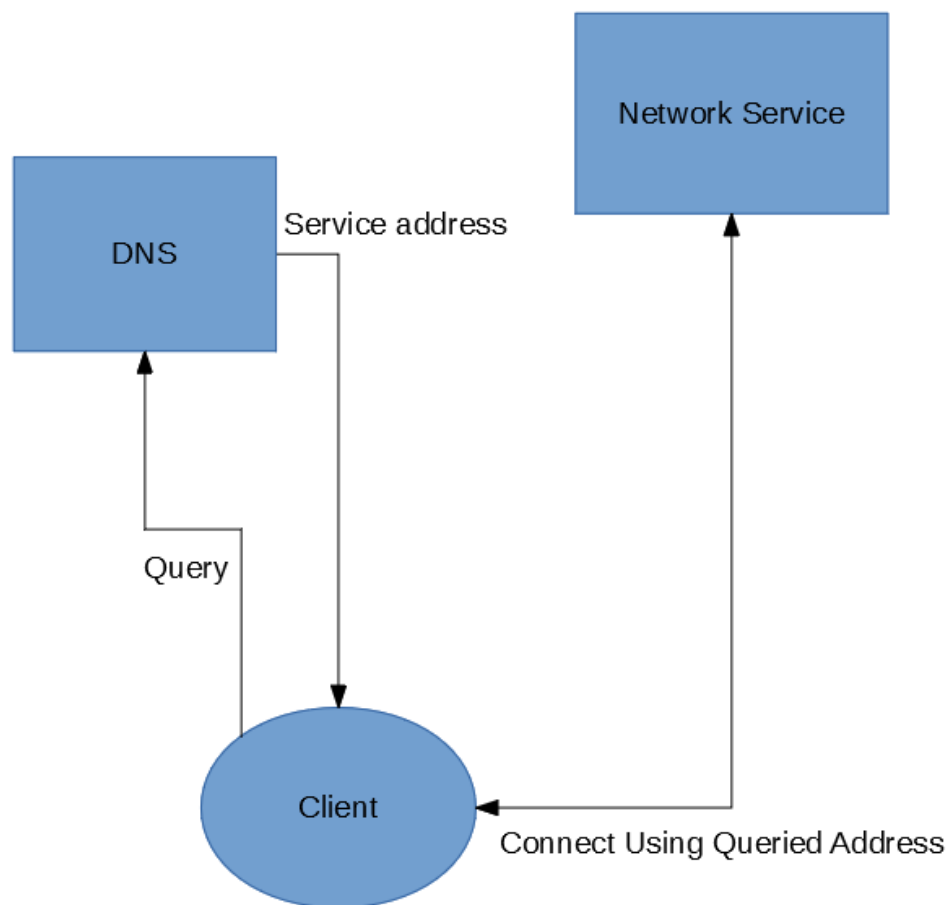

Figure 38. Example of DNS-SD based discovery of a network service

UDP Broadcast-based Discovery

UDP Broadcast can be used to send UDP packets to all computers on the LAN simultaneously, and by programming the devices on the network to respond to the UDP packets in question, they can thus all be identified and logged by the hub. This method has the advantages of being much faster than a network scan while involving less overhead yet is simultaneously less complex and configuration-intensive than the DNS-SD method

outlined above. The primary downsides to this method include the fact that it generates more network traffic than the DNS-SD based method and will also not work across multiple subnets, but in the home-LAN environment in which we are planning to deploy the system, these concerns are relatively marginal. This goes doubly so when considering the fact that the hub will only need to discover new devices on occasion, either during initial setup or when new devices are installed in the household.

In figure 39, a general diagram of how UDP-Broadcast based device discovery can be achieved is depicted. The packet sent to the routing device is transmitted to all the devices on the network (shown as blue arrows), and then only those devices programmed to respond to said packet reply to the hub device, which can then log any relevant data (IP Addresses, MAC addresses, etc) for later use in communicating with said devices.

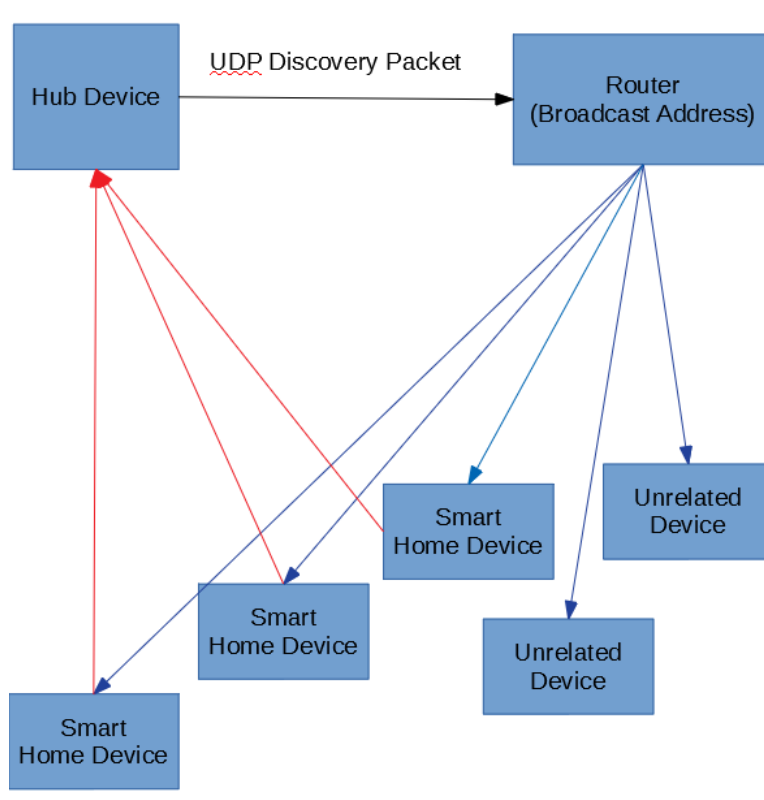

Figure 39. Example of UDP-Broadcast

Another method by which devices which are to be controlled by the hub might be connected involves the use of a Wi-Fi direct connection between the hub and the devices themselves. This approach brings with it significant advantages over the plan which has the devices connect to the hub via the user's LAN. As outlined in the networking overview, creating pre-configured headless devices designed to connect to a secured wireless network presents several challenges related to how to relay the necessary security details to the device in question. Connecting directly to the hub via a Wi-Fi direct connection eliminates these issues, as the devices can be pre-configured with the necessary details required to

make a connection with the hub, and thus need not concern themselves with the details of the user's wireless network.

This method is also beneficial in the sense that it renders the need for a robust device-discovery method moot. Because no devices other than those which are part of the smart-home system are expected to be connected to the hub via Wi-Fi direct, this listing of devices should service as an adequate directory from which the hub can poll for information or receive status updates. This also simplifies the configuration of the smart-home devices connected to the hub, as there is no longer any need for them to connect with the hub to acquire its IP address. In this case, the devices need only be pre-configured with the SSID of the network the hub broadcasts and the relevant security information.

Given the greater simplicity of this solution as opposed to the alternatives outlined above, we have opted to simply make use of a direct Wi-Fi connection to the hub rather than carrying out the network discovery-based solutions outlined further above.

A Raspberry Pi 3 can be configured to act as a Wi-Fi access point via the use of WPA-Supplicant and the proper configuration profiles. An example configuration profile, which allows the device to act as an access point, can be seen below:

```
ctrl_interface=DIR=/var/run/wpa_supplicant
update_config=1

ap_scan=1
device_name=SmartHome_Hub
device_type=1-0050F204-1
driver_param=use_p2p_group_interface=1
driver_param=p2p_device=1
p2p_go_intent=10
p2p_go_ht40=1
```

Figure 40. Example of Configuration Profile

Likewise, the profile can then be run with a command such as:

```
sudo wpa_supplicant -B -dd -iwlan0 -Dnl80211 -c
/etc/wpa_supplicant/wpa_supplicant.conf
```

This command can be programmed to run at a pre-determined time (I.E. shortly after system startup), ensuring that the direct connection access point comes online reliably.

5.2.5. Client-Server Communication

Having a clearly-defined API for communication between the client and the server is paramount, as it will not only determine what networking functionality is available to the relevant devices, but also serve as a blueprint for what methods and functions must be developed in order to produce the desired functionality on relevant machines. There are numerous key features which must be included within the client-server API to ensure that the system can provide the functionality outlined in the project goals and objectives. Since we have opted to develop this API as a web service, there are several options available, the most popular among them being SOAP and REST.

5.2.5.1. Simple Object Access Protocol

SOAP (Simple Object Access Protocol) carries out information interchange using the XML format and is by and large the more mature protocol for developing webservices. It offers a higher degree of complexity than is available to REST, including storing state across multiple transactions (though SOAP is stateless by default) and is functionality-driven by design, I.E. based on the paradigm of creating functions which perform a given action or retrieve/receive a given piece of data. SOAP has its advantages and sees heavy use in both legacy systems and the financial sector, but due to its use of XML and because of the extra rules and complexity implicit in the protocol, it is more resource-intensive and can often be more difficult to use. Likewise, since most of the communication we expect to be doing is more data-driven than functionality driven, SOAP is not, by its nature, the best fit for the type of work we expect our system to be doing.

5.2.5.2. React JavaScript

As the development process progresses, it is becoming more clear which technologies we will be likely using in our system. As we have shown in figure 52, in order for something like so to be achieved it is likely we will also need to implement in our front-end frameworks another library, more specifically React. React is a JavaScript library developed by Facebook to streamline the process of creating interactive user interfaces. We have said that we want to create a dashboard for our user where they will be able to see, for example, the power usage of their devices. This is a perfect example of where React could be used to display such information. Say we display this information in a graphical way, as shown in the mockup in figure 52. In order to correctly populate the graph with their specific information we could use React to dynamically display it.

The REST (Representational State Transfer) webservice protocol has been selected as the protocol upon which to build the client-server communication API. Being an system for representing data clearly in various formats such as text, JSON, and XML, REST is an ideal candidate for the construction of our API because, unlike SOAP, messages data can be encoded in a JSON format which is significantly more lightweight than SOAP's more bandwidth-intensive XML format, which will result in faster communication and lower bandwidth usage overall. REST is also better suited to tasks which involve the retrieval and management of data, rather than the more functional-transactional orientation of SOAP. This feature makes it highly effective at meeting our needs, as the client side hub will need to be able to provide the server with a clear and complete listing of all the smart-home items on the user's network which includes information about the type, functionality, and status of said items, and this type of information lends itself readily to being encapsulated in an object or structural datatype which serves to define the real-world item to which it is associated.

Although REST-based systems can transmit data in a number of formats, we've chosen JSON as the primary format because, as stated above, it is not only significantly less verbose (and therefore, easier to type if necessary and also less bandwidth-intensive) than XML, but can also be parsed more quickly by most software, freeing up system resources which would otherwise be spent on the task of parsing incoming data.

5.2.5.3. Django REST Framework

Since we have already decided to use Python with Django as the basis of our server backend, it makes sense to use the Django REST framework for the implementation of the API, as it fits with our pre-existing software ecosystem and provides the required service by design. The Django rest framework provides useful abstraction and tools which will help to ensure that the relevant software produced can both be completed in a timely manner and reduce the frequency of technical faults which might otherwise arise.

5.2.5.4. Vue.js

As an alternative to the React framework. We could also use in our system another framework called Vue.js. Similar to React it is used to easily create user interfaces, however instead of using JavaScript-based templates, it uses HTML-based templates. Because of that, we believe that integrating Vue with our current back-end framework will be easier than utilizing React since Django also uses HTML templates.

Key Functionality

One key feature which should be provided by the API is the ability for the hub to register itself with the server, and to do so in such a way as to allow a user account to then be associated with it. This type of message will likely only be sent once, during initial setup of the hub proper. Afterwards, the user should be able to use a code or some other means to identify themselves as the owner of the device and register it to their account, giving them access to the functionality of the hub in question.

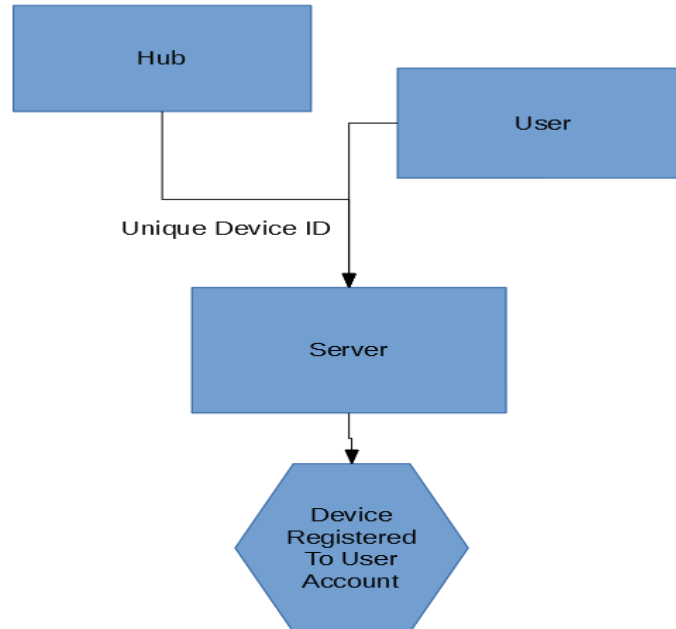

Figure 41. Account and Hub Association Diagram

Another key feature will be the ability of the client to register devices on the network with the server, including information about the type of device and its current status. This is important for providing the user with granular control over the individual devices

connected to the smart-home system by allowing the server to enumerate a list of said devices and their current status, and to allow the user to make modifications to the behavior and patterns of said devices, which are then picked up by the client-side hub and relayed to the devices themselves.

Just as the hub should be able to register devices, it should also be able to inform the server when devices are disconnected or can no longer be communicated with via the local network. To that end, the ability to communicate that the server should delete references to items which no longer exist should also be a part of the core networking API functionality.

The server should also provide a means by which the hub can update the status of specific connected devices, i.e. to log the state of a motion sensor or to tell the server whether a specific smart outlet or light is turned on or off, or to tell the server whether an electronic door lock is locked or unlocked if one is connected to the system, or to provide the current temperature settings of an in-house thermostat which is being controlled by the hub.

Certain device statuses should be considered an ‘alert’ condition, i.e. infra-red sensors detecting a fire, or the triggering of certain motion-sensors at certain times of day (for example, the user expects to be at work and for their home to be empty, but a motion sensor is tripped.) In these conditions, the client can add an alert to the server which can then be either displayed on the relevant webpage or trigger some other action which serves to inform the user of the alert and its nature.

Finally, the server will also implement a means for the client to poll for changes to the user’s preferences or commands which are to be carried out on devices connected to the hub.

Given this list of criteria, it is easy to see why REST is a good fit for the task which we wish to accomplish. Many of the above criteria can, in fact, be organized as different http ‘verbs’ working on the same URI, as almost all of the tasks in question relate to updating, adding or deleting members in a set of data objects. The language of modifying or updating information about a set of objects is practically built into the structure of REST, and tasks which REST is not a good fit for are generally either not present in our project scope or of relatively minimal prevalence.

An example of how an API could be defined to handle the interchange of data regarding devices connected to a hub is shown in table 17.

Table 17 HTTP Methods

HTTP Method	URI	Description
GET	hubs/(id)/devices/	Get a list of devices registered with the server.
GET	hubs/(id)/devices/(deviceid)	Get the information of a single device with the given deviceid registered on the server.
POST	hubs/(id)/devices/(deviceid)	Add a new device with the given ID to the server's list of registered devices for this hub.
PUT	hubs/(id)/devices/(deviceid)	Update the details of the device corresponding to the given deviceid on the server.
DELETE	hubs/(id)/devices/(deviceid)	Delete the information on the device with the given deviceid in the URI as shown from the server.

JSON Object Format

Because the user will have the opportunity to install multiple different types of device, with different functions, feedback, and formats, the system will need to be able to handle and transmit all information relevant to the device in question. However, since the various devices used as part of the system will each have their own data requirements (I.E. an air conditioner unit will require information related to whether the unit is currently on, what the desired temperature is, etc) and because it is in our best interest to prevent the footprint of JSON messages between the client and server from growing with every new type of device added, it makes sense to format our JSON device objects in such a way that the consist of an outer wrapper which contains all the data which is shared by all device objects and information as to what type of device is being represented, and an inner nested object which contains all of the relevant device-specific data.

This should allow for the data footprint to remain relatively small and consistent, while still providing the flexibility necessary to represent the myriad supported devices which must be controlled by the smart home system.

The structure which will be used by the device objects will be outlined in detail here once it has been decided upon and finalized, and may be extended during development to meet the needs of the system if any new fields prove to be necessary to provide the desired functionality.

Consistency will need to be maintained between the data that the server expects and what the client sends, mostly because the server will be performing validation on JSON which is received through the REST API, and thus any changes to the data required by the server

will likewise need to be accompanied by changes to relevant code on the client-side. In the event that a request to the server is invalid, the Django REST framework will automatically provide fitting HTTP responses which detail the error in question, which should assist in the process of debugging any such errors.

Below in figure 42 is an example of how a POST method transaction involving devices can be carried out via the API, with device-type specific information included in the overarching device JSON object as an embedded object, which in turn possesses the requisite members to describe the device in question. Following a successful POST transaction, the client receives a JSON object which contains the device ID assigned to the registered device on the server which can be recorded and used to refer to that specific object in all future communications.

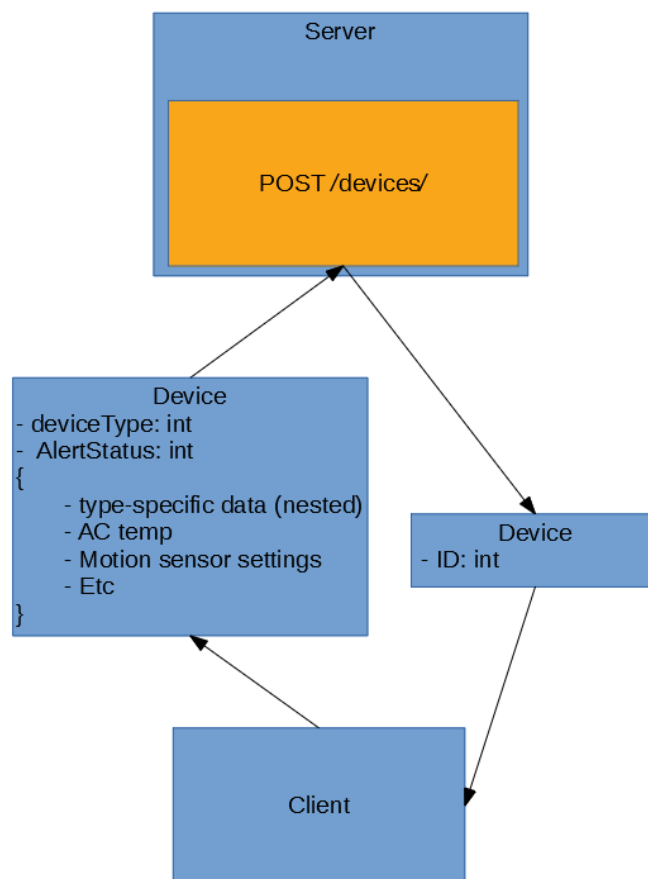

Figure 42. Example of POST Transaction

Below is a listing of the fields which will make up the body of JSON objects passed between the hub and the server, in tabulated format.

Table 18 Outer JSON Fields

Field	Data Type
ID	Integer
DeviceType	Integer
AlertStatus	Integer
Device	Nested JSON

Device-Specific nested JSON tables:

Thermostat

Here, the color-coded variables correspond to the current status of the wires connected to the thermostat and can be used to determine the current status of the air conditioner, I.E. whether the indoor fans are running, whether the air conditioner is currently running, and whether the system is in heating or cooling mode.

Table 19 Thermostat JSON Fields

Field	Data Type
Temperature	Integer
Red	Boolean
Yellow	Boolean
White	Boolean
Orange	Boolean
Black	Boolean

Outlet

The required data from the outlet includes whether or not the outlet is currently toggled on or off by way of the system, whether current is flowing through the outlet (I.E. an outlet which is toggled on but which there is no device plugged into would not experience a current), and the measured electrical consumption provided a current is present.

Table 20 Outlet JSON Fields

Field	Data Type
Toggle Status	Boolean
Current (is present)	Boolean
Current (consumption)	Integer

Sensors

Although the sensors used in this project produce a variable output DC voltage dependent on the conditions which they are observing, it will be the responsibility of the microcontroller devices to which they are connected to translate these outputs into boolean values which equate to a ‘triggered’ or ‘un-triggered’ state, which will then be reported to the hub.

Table 21 Sensors JSON Fields

Field	Value
Triggered	Boolean

Security

Because REST webservices make use of HTTP, many of the same techniques for securing a traditional website can and should be used to secure a REST API. For example, database and SQL inputs which contain data obtained through the API should be checked and sanitized before it is entered into the DBMS, in order to prevent SQL injection attacks. Care must be taken to use the HTTP GET method properly, as improper usage can place sensitive information such as usernames, passwords, or important session data in the URL string. Such information should be communicated only through methods such as the HTTP POST method, or other methods which do not expose said sensitive data.

Because clients are responsible for formatting and serializing JSON objects into a format which is valid and proper for use with the webservice API, it is important both for the sake of system stability and security to ensure that JSON received by the API is validated upon receipt to ensure that it matches the format laid out in the API documentation. Luckily, the Django REST framework provides built-in tools for ensuring that the structure of received JSON matches the format specified in the relevant serializer used in defining the API, making the task of ensuring that incoming data is valid simple trivial for us.

5.2.6. Software Block Diagram

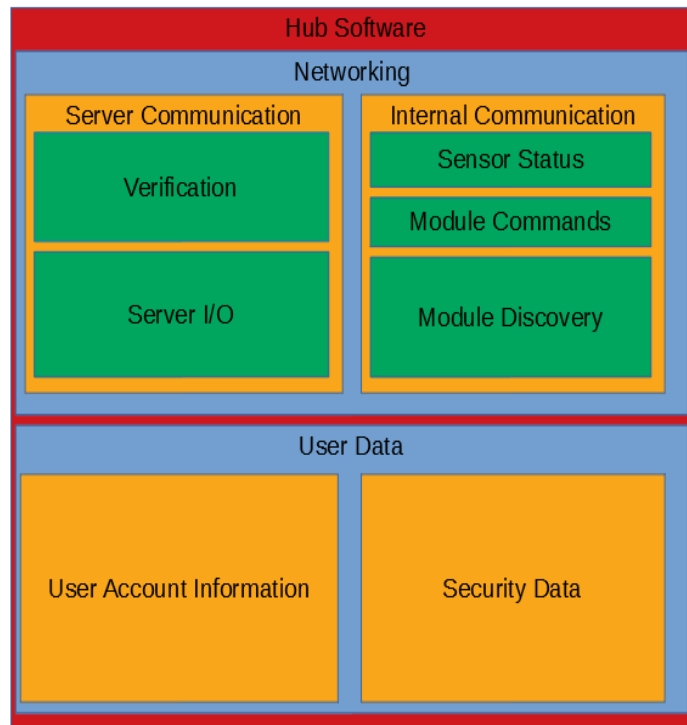

Figure 43. Tentative Block Diagram

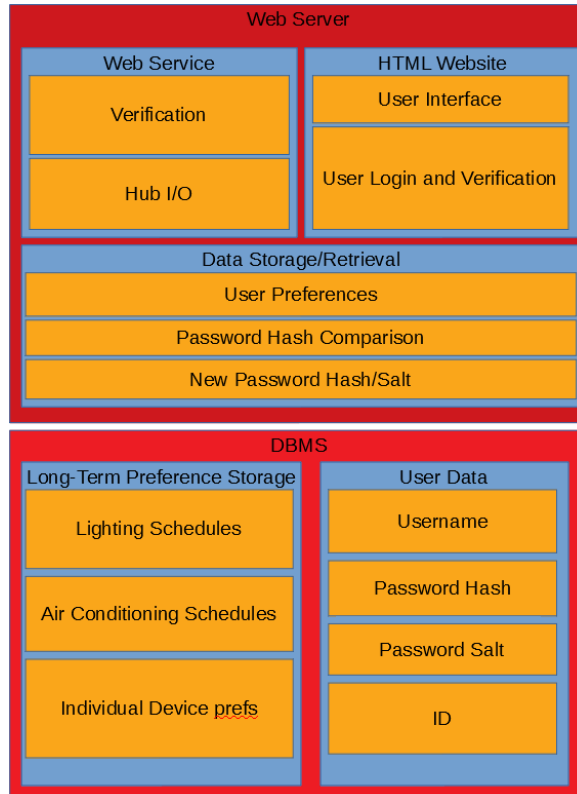

Figure 44. Tentative Block Diagram

5.2.7. Auxiliary Services

We have previously discussed in Section 3.2 the different cloud services available for use regarding the hosting of our web server. Our top two candidates were Digital Ocean and Amazon Web Services. We have said we would be using both of these providers in unison and that is still the case. With AWS, we are able to implement, for example, a feature where the user of our system will be able to reset their password through their email, and this is possible because of the integration of our web server provider and an AWS service provided by AWS, called Simple Email Service (SES). Utilizing SES, we are able to setup the domain name of our system to utilize records provided by AWS which will route the email messages pertinent to password reset action.

Another way we will be utilizing services provided by AWS within our project is by using Amazon Simple Storage Service (S3) to serve our users with the static files for our website. Even though our back-end framework is capable of doing so, it is recommended by them that for deployment of a project that will be used in production, such as ours, that the use of third-party services to serve end users static content to be preferred. That recommendation is given because the Django's system is inefficient and insecure, according to their documentation [8].

5.2.8. System Security

Security is of utmost importance for us and the future users of our system. It is important to note, that by providing this service to our end users, we are not providing, however, a security system. Rather, we will do our best to provide a secure system that should, by

utilizing tools already established in the security ecosystem provide an environment that will be immune to most common intrusion attacks, for example unauthorized user access.

5.2.9. Class Diagrams

In this section we will provide the reader with Unified Modeling Language (UML) diagrams related to how a user account, will be organized in the database system of our choice. In future versions of this document, we will also include diagrams for other aspects of our web application.

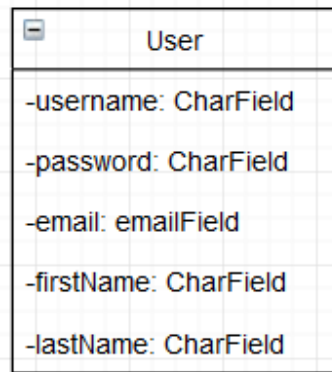

Figure 45. User UML Diagram

In figure 46, it is shown a Use Case Diagram of the user registration and login as well dashboard and profile management. The user if not registered will have the option to create a new account. Once such step is completed, the user will be taken to their homepage where they will have access to the dashboard where they will be able to control the devices installed within their system, as well the ability to check the usage of such devices. Another option provided to the user, will be profile management, where for example they will be able to change their email address or reset their password.

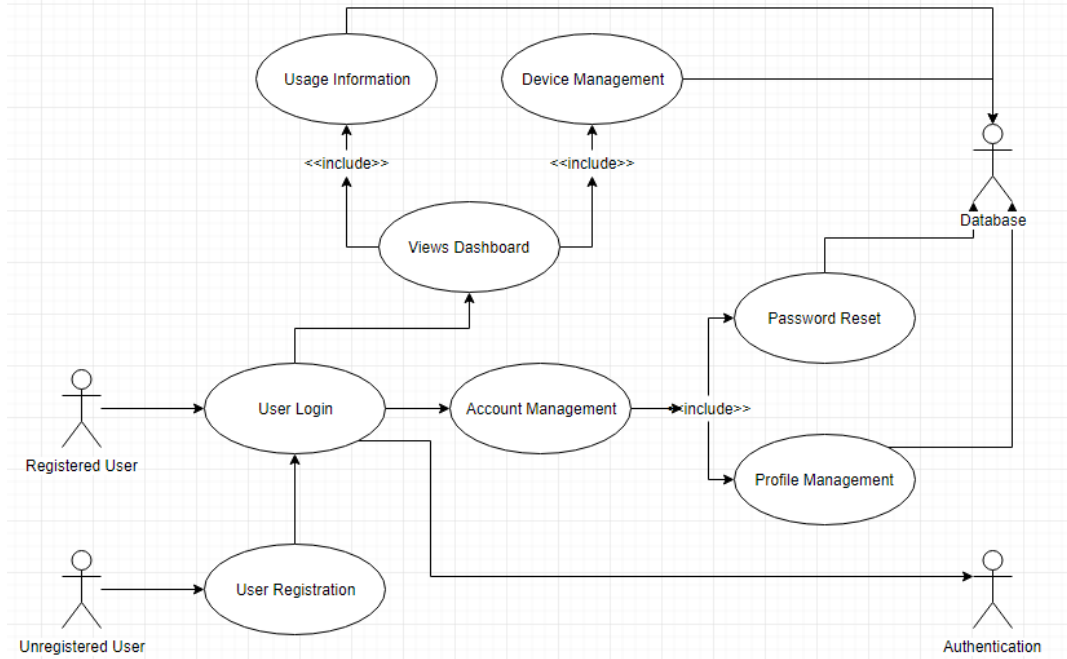

Figure 46. User and Dashboard Management

5.2.10. User Interface Overview

We believe that usability of our system plays big a part in the overall project. As such, we have spent careful time in consideration on how the user interface will be constructed, and which elements we can implement to have an easy-to-use system which can attend all of our user base. As we have previously mentioned, we have a few options for the front-end web framework being used. In figures 47 and 48, we can see different examples of how we imagine the login web page is going to look like for the final version of the project.

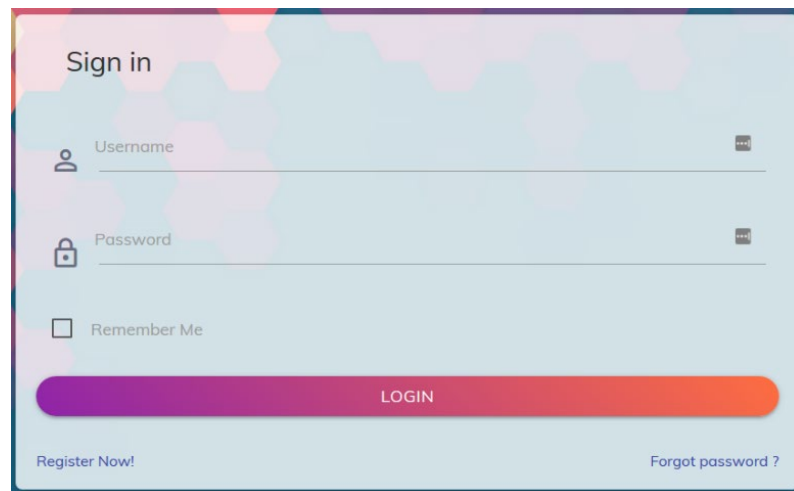

Figure 47. Login Layout Utilizing Materialize CSS

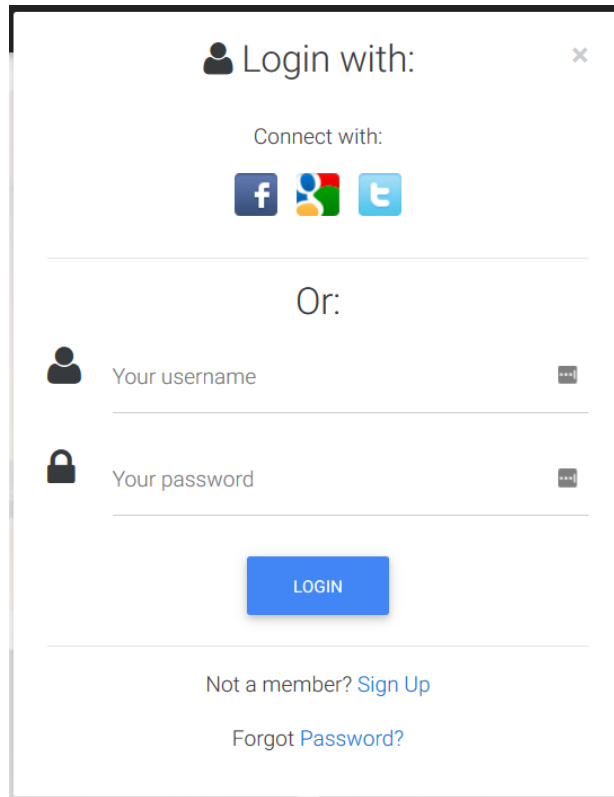

Figure 48. Login Layout with Material Design for Bootstrap

Both of these designs are considered appealing by us, and they are both very similar to what we envision as our final design. As the development phase begins, we will keep these ideas in mind and decide which one will work better with the other sections of our web application.

With some parts of development processes already started, we can now discuss more about the user interface. Mainly, we will discuss about the interface for account management. In figures 49 and 51, we can see how we have implemented our web framework of choice, Material Design for Bootstrap, to create a login and a registration page.

We have decided to utilize a very simple interface. We want to provide our user with a clutter free workspace which can still attend all their needs. If time permits, we will also allow our users to login with their social media accounts to further streamline the process. Doing so, we will be able to reduce the number of accounts a user has to remember. The current layout for our login page can be seen in figure 50 below.

Figure 49 shows a login form with a dark blue header containing the word "Login". Below the header, there are two white input fields: "Username*" and "Password*". A blue button labeled "LOGIN" is positioned below the input fields. At the bottom of the form, there are two links: "Forgot Your Password? Click Here" and "Don't Have an Account Yet? Register Here".

Figure 49. Login Form

The same idea was applied to our registration form. In figure 51 we can see one implementation of the current registration page. As shown, for now, a user needs to create a username, provide their first and last names, create a secure password, and provide us with their email address. After submitting the form, the user will receive in their mailbox a confirmation email from our system, asking them to verify their newly created account. This will serve as an extra security measure to prevent unwanted accounts. After confirming the creation of the account, the user will now be able to login, and therefore they will be able to manage the devices they have installed at their household. We have planned for our users to have access to a dashboard where the available devices will be shown so they can be managed. In a future update, we will remove the password and username requirements of the screen and these will be shown only when the user hovers over their respective dialogs.

An updated version of the login screen is provided in figure 50, now with the ability for the user to login into our system with the use of their social media account, such as Google or Facebook. If additional services are required, they can be easily integrated. As the development continues, alterations can still occur to the user management portion of the system.

Figure 50 shows a login form with a dark blue header containing the word "Login". Below the header, there are two white input fields: "Username*" and "Password*". A blue button labeled "LOGIN" is positioned below the input fields. Below the "LOGIN" button, there is a section titled "Or Login Using Your Social Account." with two buttons: "GOOGLE" and "FACEBOOK". At the bottom of the form, there are two links: "Forgot Your Password? Click Here" and "Don't Have an Account Yet? Register Here".

Figure 50. Social Media Login

The image shows a registration form with a dark header containing the text "Sign up". Below the header are several input fields: "Username*" with a note "Required. 150 characters or fewer. Letters, digits and @/./+/-_ only.", "First name", "Last name", "Email*", "Password*" with a list of password requirements: "Your password can't be too similar to your other personal information.", "Your password must contain at least 8 characters.", "Your password can't be a commonly used password.", and "Your password can't be entirely numeric.", and "Password confirmation*" with a note "Enter the same password as before, for verification.". At the bottom is a "SUBMIT" button and a link "Already Have an Account? Sign In".

Figure 51. Registration Form

Having an account is a crucial component of our system. Our users will be able to access the devices installed in their household from anywhere with an internet connection. When a user is logged in, they will be presented with a dashboard with a slew of features and management options for their devices and account. The user will be able to manage their account and will have the option to reset their password, change their email address, email, and username. They will also be able to modify their dashboard with respect to their devices as they see fit. For example, they will be able to create custom names for their outlets, so it is easier to identify them and control them. They will also be able to monitor the temperature of specific rooms and check the power usage of various systems. Having this feature available will allow the user to have a better understanding of which devices are utilizing more power and this could possibly lead to a better power usage and ultimately reduce their power cost. With the web interface, the user will also receive alerts regarding motions captured with our sensors or regarding a possible fire in one of their living areas, such as the kitchen. A flowchart of how we envision the registration and login steps to work can be seen in figure 56. We have not yet started implementing the dashboard in our current development version; however, we do have some expectations on how it can look like. In figure 52 we can see a mockup layout to what we will be aiming to.

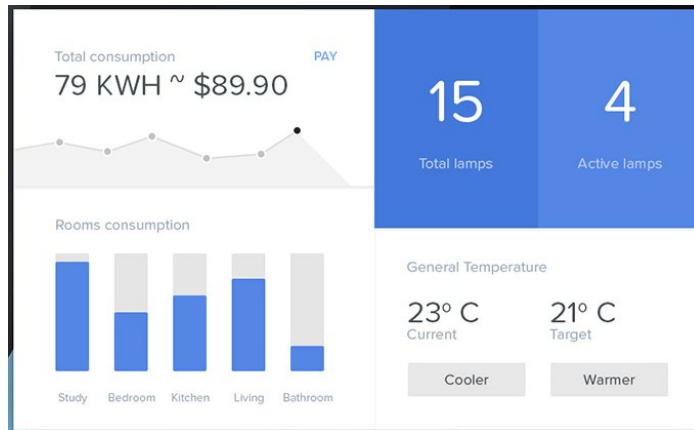

Figure 52. Dashboard Overview Example

Source: <https://bit.ly/2xQbw8y>

The user will also be able to view and edit their profile information provided during registration. In figure 53 we have an example of how such information will be shown to our users.

The 'My Profile' form displays the following information for the user 'TestUser1':

Field	Value
Username	TestUser1
First Name	Test
Last Name	User1
Email	testuser@hsas.site

Below the form is a prominent blue button labeled 'EDIT PROFILE'.

Figure 53. Profile Information

Figure 54 shows the interface for editing a user profile.

Figure 54. Profile Editing

As we have previously mentioned, we will also allow the user to control their devices through the dashboard. One of the features of our system will be the ability to control outlets throughout the household. For example, if a user will not be at home during a certain time frame, they could access their dashboard and would be presented with a simple interface, as shown in figure 55, and deactivate a specific outlet in order to save energy.

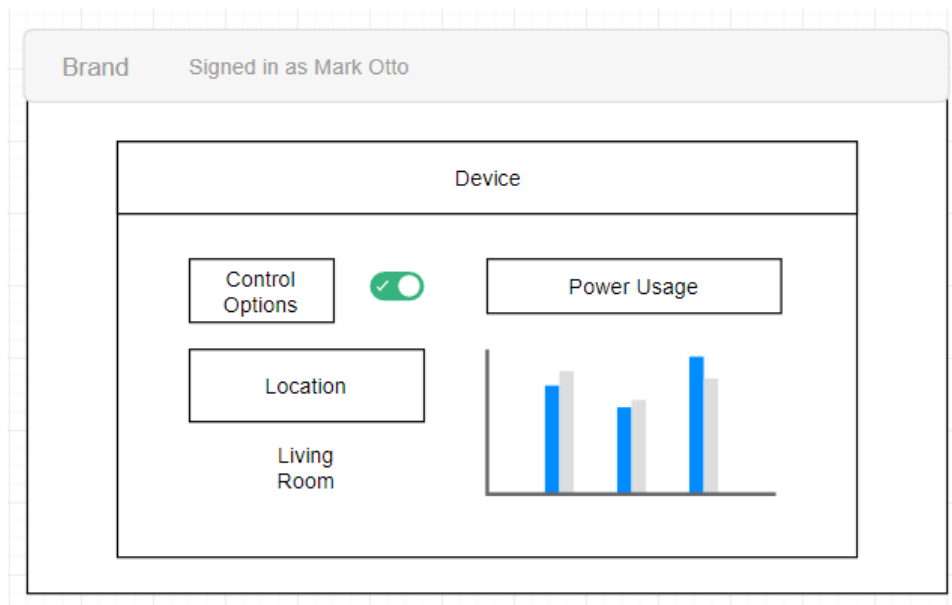

Figure 55. Example of Outlet Control

As observed in figure 55, we will provide the user with an easy-to-use interface where all the information they need for the device is readily available in a single screen. We believe that in this way we can facilitate the usage of our system and optimize the time of our users.

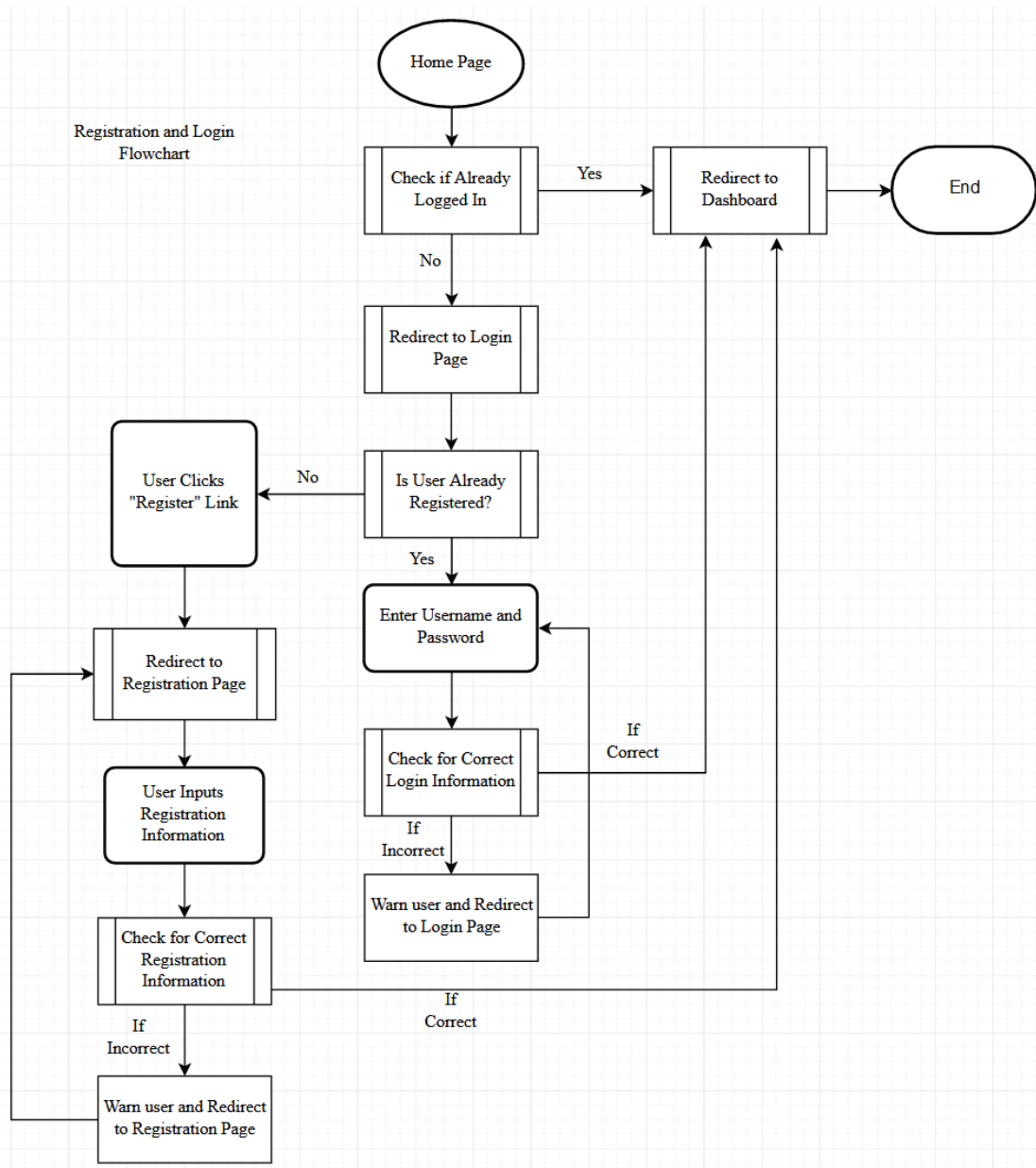

Figure 56. Registration and Login Flowchart

Another feature that will be implemented for the account management portion of our system is the option for a user to recover their password in case they have forgotten or lost it. The user will be guided through a series of steps which involves them confirming their identity, providing us with their registered email and then receiving a confirmation email where they will be able to reset their password. On figure 57 a flowchart shows how this process will work.

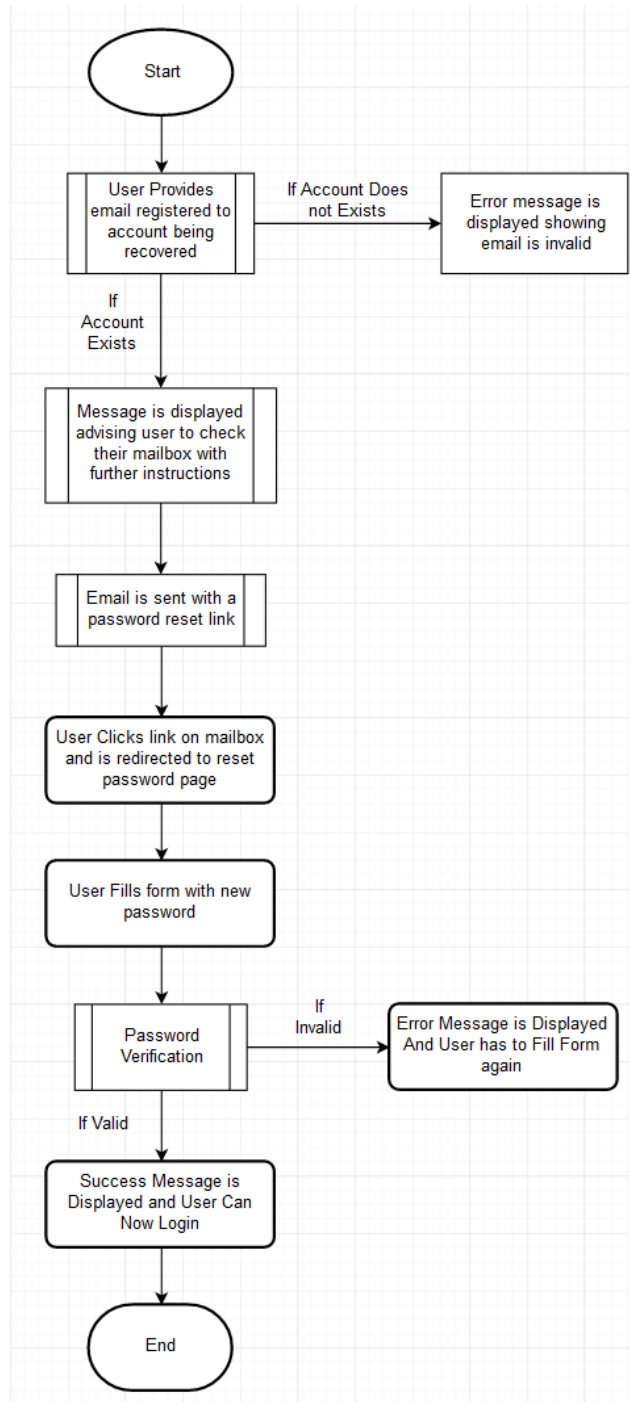

Figure 57. Password Reset Flowchart

5.2.11. Database Schema Overview

In order for the system to work properly, we have to store the user information. As we have discussed previously in Section 3.2.7, we are utilizing in our system a MySQL database. This database will store many values that are connected to a specific user and to a specific device in such user household. A tentative database schema is presented in figure 60. Also, in table 22 we can see the current schema for the functionalities already implemented.

Table 22 Current Database Schema

Table Name
auth_group
auth_group_permissions
auth_user
auth_user_groups
auth_user_user_permissions
django_admin_log
django_content_type
django_migrations
django_session

If we take a closer look at one of these tables, we can see which kind of information we are storing. For example, the information stored in table *auth_user* can be seen in figure 58.

id	password	last_login	is_superuser	username	first_name	last_name	email	is_staff	is_active
1	pbkdf2_sha256\$	2019-07-15	1	gcosta	Guilherme	Costa	gamorimc@knights.ucf.edu	1	1

Figure 58. Example of User Information in Database

```

_id: ObjectId("5d2debedc279caf951f10d4f")
id: 1
password: "pbkdf2_sha256$150000$35umy1uKh1Ev$1fCdo/MesE2ks7BKyrUysJ5YJZQ306HieWYQ..."
last_login: 2019-07-16T15:24:27.000+00:00
is_superuser: true
username: "gcosta"
first_name: "Guilherme"
last_name: "Costa"
email: "gamorimc@knights.ucf.edu"
is_staff: true
is_active: true
date_joined: 2019-07-16T15:23:25.000+00:00

```

Figure 59. Example of User Information Stored with MongoDB

As seen in figure 58, we have most of the same fields as the ones described in section 5.2.4, when the user created their account and as well as extra fields that can be access by the user dashboard, and also fields that are only accessible by the system administrator, in this case, we the developers. Also, we can see in figure 59 that if we were to use MongoDB as our database system the organization would be a little bit different, namely in a bson format instead of a table format, however the functionality would be the same. It is important to notice that even when accessing the user information through the database visualization application, a user's password is hashed to prevent unauthorized access. This is a feature of our back-end framework of choice, Django.

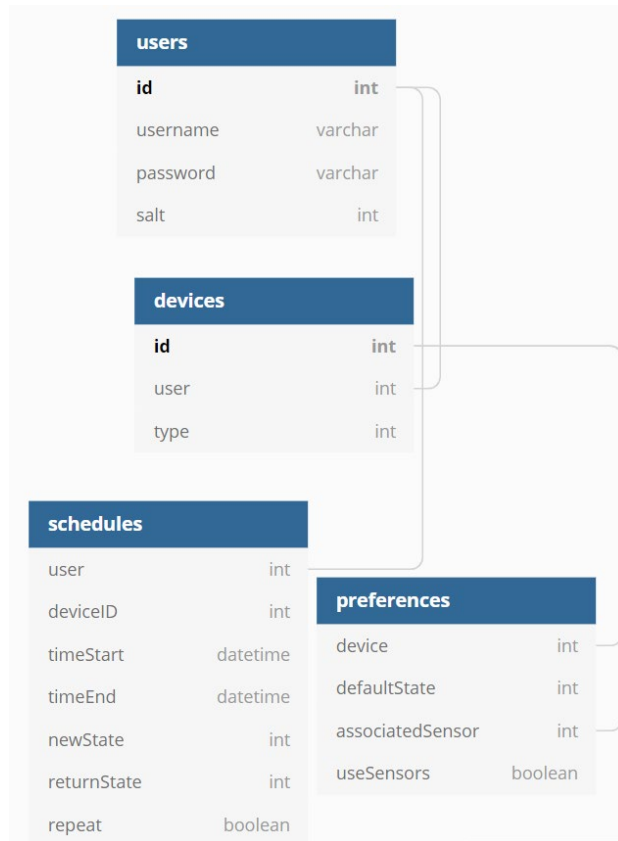

Figure 60. Tentative Database Schema

5.3. Optical Design Details

We are utilizing a silicon photodiode for the fire detection circuit because it is cost effective. The sensor can detect emissions in the 0.7-1.1 μm wavelength range which is near infrared and a small portion of the blackbody spectrum of fire. An InGaAs photodiode may be more effective at fire detection because it can detect up to 1.7 μm wavelength and this is closer to the peak of fire's blackbody spectrum, but an InGaAs photodiode is much more expensive than silicon photodiode, so we opted to use the Silicon photodiode, shown in figure 61.

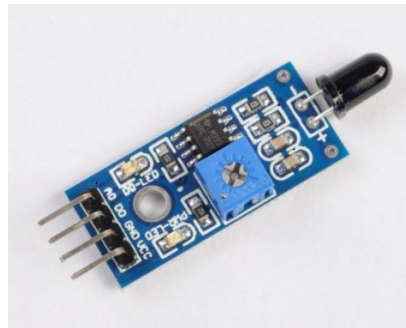

Figure 61. Silicon Photodiode with Circuit Board

Source: <https://ebay.to/2S0hTiS>

We have chosen to utilize a single lens system to increase the detection range of the photodiode as well as its field of view. The diode is only about 3mm in diameter allowing only a very small amount of incident power to be absorbed. The lens we have chosen is about half an inch and it will focus about four times the amount of incident radiation onto the center of the diode. The single lens system is housed in a small aluminum box due to aluminum's high reflectivity for infrared waves. This will allow any incident radiation that wasn't completely focused onto the diode to be reflected back onto it.

We are considering utilizing a band-pass filter with peak wavelength around 940 nanometers due to the sun's transmission spectrum through the atmosphere. Water vapor absorbs a large portion of radiation around 940 nanometers, so even though it is relatively close to the peak of the blackbody spectrum for the sun not much is transmitted through the atmosphere. This would mean there is less environmental noise at this wavelength, so we could increase the signal to noise ratio of the photodiode system and decrease the amount of false detections.

We are still exploring options for the mounting of our PIR photodiode, but we plan to use something simple and able to be mounted to a wall. We looked through two separate options for our motion detector and decided on the one depicted in Figure 62. We chose this photodiode because of the superior field of view and proximity.



Figure 63. Passive Infrared Photodiode



Figure 62. Passive Infrared Photodiode

Source: <https://ebay.to/2xxyXDt> and <https://ebay.to/2XtAgCX>

We've chosen to use a N-BK7 lens for our fire detector module with a focal length of 25.4 millimeters. We will position the photodiode directly behind the focal length at about 26.9 millimeters away from the lens to capture more light from flames. The following calculations were made to find optimal sensor positioning for the best field of view and most incident radiation. We used a maximum sensor range of 2 feet to allow optimal short-range results.

$$\frac{1}{s} + \frac{1}{s'} = \frac{1}{f}$$

Equation 5.3.1 Gaussian Lens Equation

$$\frac{1}{x} + \frac{1}{24} = \frac{1}{1}$$

$$x = 1.043 \text{ inches} = 26.9 \text{ millimeters}$$

6. Prototype Testing

In the following sections we will discuss in detail how we have planned the testing portion for our project. These sections will be separated in both Hardware and Software testing.

6.1. Hardware Testing

The following test plans will be used to test the functionality of each component of the units we are building, this will ensure that the hardware is working properly prior to, and after assembly. By ensuring the hardware is functional we can deduce that bugs that occur in further testing will be more likely software issues which will be far easier to fix than hardware malfunctions. Each table is designed to be a printable form that the engineer assembling the product can use for Quality Assurance of the Unit.

6.1.1. AC Thermostat Testing Plan

This plan will be used as a sanity check before and after assembling our devices. It is inevitable that when we are assembling or programing theses integrated parts, we are going to run into unexpected issues. These parts are not made by the same manufactures, they have different properties, require different voltages, and its not gurranteed that one module will integrate with another even if all our research finds that everything should work. To provide us with a way of tracking down possible issues before it becomes very difficult to find and fix them, we will follow these testing guidelines. These tables are set up in a way that they can be used as checks for each component of a device before we permanently install it on the circuit board. By doing this we will save a vast amount of time by ensuring that the hardware isn't what's broken and the likely issues are software related.

Table 23 AC Thermostat Hardware Component Testing Plan

Product Name	Component Name	Test Type	Testing Instructions (Using all Safety Precautions)	Expected Results	Pass/Fail
AC System Controller	Power Supply	Power On	Using a modified AC cord connect the input terminals of the power supply with the Hot wire in the + terminal and the neutral wire in the - terminal and with a digital multimeter (DMM) ensure that 24V is measured at the Output terminals	Multimeter reads 24V at Output Terminals (10% Deviation Allowed)	

Table 23 Continued

Product Name	Component Name	Test Name	Testing Instructions (Using all Safety Precautions)	Expected Results	Pass/Fail
	Step Down Voltage Regulator	Power On	With the power Supply powered on, connect the Voltage Regulator input terminals to the Power Supply's output terminals. Using a DMM, ensure that the Output Terminals of the Voltage Regulator measure 5V.	Multimeter reads 5V at Output Terminals (10% Deviation Allowed)	
AC System Controller	Relay Board	Power On	Using the Powered Voltage Regulator or another 5V power supply that can be connected to the Board's DC input power the board and ensure the LED in position D2 is powered on and no other LED is ON	D2 LED ON, all Other LEDs OFF	
AC System Controller	Relay Board	Power On	Verify using a DMM that the +5V pin of the ESP8266 chip reads 5 Volt	DMM measures 5V (10% Deviation allowed)	
	Relay Switches	Operational	Send UART message to relay board to Close S4	Relay S4 is Closed, LED D10 is ON	
			Send UART message to relay board to Open S4	Relay S4 is Opened, LED D10 is OFF	
			Send UART message to relay board to Close S5	Relay S5 is Closed, LED D8 is ON	

Table 23 Continued

Product Name	Component Name	Test Name	Testing Instructions (Using all Safety Precautions)	Expected Results	Pass/ Fail
AC Controller System	Relay Switches	Operational	Send UART message to relay board to Open S5	Relay S5 is Opened, LED D8 is OFF	
			Send UART message to relay board to Close S3	Relay S3 is Opened, LED D4 is OFF	
			Send UART message to relay board to Open S3	Relay S3 is Closed, LED D4 is OFF	
			Send UART message to relay board to Close S2	Relay S2 is Closed, LED D3 is ON	
			Send UART message to relay board to Open S2	Relay S2 is Opened, LED D3 is OFF	
	Temperature Sensor	Operational	Connect the sensor using USB to TTL UART and verify temperature is being read in.	Digital Output from Sensor reads the measured room temperature (5% Deviation Allowed)	
AC System Controller (Assembled)	System	Logical	Wire the thermostat by the corresponding terminal wires. Verify Functioning Red Terminal	Red Terminal Measures 24V +-10%	
			Verify Functioning Green Terminal	Green Terminal Measures 24V +-10%	
			Verify Functioning Yellow Terminal	Yellow Terminal Measures 24V +-10%	
			Verify Functioning White Terminal	White Terminal Measures 24V +-10%	

6.1.2. Light Switch Testing Plan

This table is a continuation of our device testing. We will emphasize that these devices are operating under high voltage and there is a great risk of shock when testing them. Testers should use all available safety precautions. Shock proof gloves are recommended when handling components like the power supplies and voltage regulators.

Table 24 Light Switch Hardware Component Testing Plan

Product Name	Component Name	Test Type	Testing Instructions (Using all Safety Precautions)	Expected Results	Pass/Fail
Wireless Light Switch (Individual Components)	Power Supply	Power On	Using a modified AC cord connect the input terminals of the power supply with the Hot wire in the PLUS terminal and the neutral wire in the MINUS terminal and with a digital multimeter (DMM) ensure that 5V is measured at the Output terminals	Multimeter reads 5V at Output Terminals (10% Deviation Allowed)	
	Relay Board	Power On	Using the PSU or any other 5V power supply that can be connected to the Board's DC input, power the board and ensure the LED indicator powered on.	LED ON	
			Verify using a DMM that the +5V pin of the ESP8266 chip reads 5 Volt	DMM measures 5V (10% Deviation allowed)	
	Relay Switches	Operational	Disconnect Relay and verify	Relay is Closed	
			Send 12V signal to relay	Relay is Opened	
	Current Sensor	Power On	Power the Current sensor using a 5V Power Supply, verify sensor LED is ON	LED is ON	

Table 24 Continued

Product Name	Component Name	Test Type	Testing Instructions (Using all Safety Precautions)	Expected Results	Pass/Fail
Wireless Light Switch (Individual Components)	Current Sensor	Operational	Power the Current sensor with a 5V PSU. Connect the Hot wire of an AC lamp's cord to the Hot terminal and the neutral wire to the neutral terminal. Leave the cord unplugged and verify the lamp is OFF. Use a DMM and measure the Voltage out, verify V _{out} is near 0.	V _{out} is ~ 0V, Lamp if Off	
			Plug the cord in and verify the Lamp is on. Test V _{out} and verify the sensor is measuring a voltage.	V _{out} is > 0, Lamp is On	
Wireless Light Switch (Individual Components)	ESP8266	Operational	Instructions TBD	Expected Results TBD	
		Logical	Instructions TBD	Expected Results TBD	
Wireless Light Switch (Assembled)	Prototype	Operational	Connect the Hot wire of a powered AC lamp to the Hot terminal and the neutral wire to the neutral terminal and ground the ground lead. Toggle switch and verify the light turns on and off	Light Bulb turns on and off	
		Logical	Instructions TBD	Expected Results TBD	

6.1.3. Smart Outlet Test Plan

This table is a continuation of our device testing. 110Vac at 15 amps can cause serious harm or death. When installing any of these wired devices, the breaker switch to the electrical box should be turned off. We will emphasize that these devices are operating under high voltage and there is a great risk of shock when testing them. Testers should use all available safety precautions. Shock proof gloves are recommended when handling components like the power supplies and voltage regulators.

Table 25 Outlet Hardware Component Testing Plan

Product Name	Component Name	Test Type	Testing Instructions (Using all Safety Precautions)	Expected Results	Pass/Fail
Wireless Smart Outlet Components	Power Supply	Power On	Using a modified AC cord connect the input terminals of the power supply with the Hot wire in the PLUS terminal and the neutral wire in the MINUS terminal and with a digital multimeter (DMM) ensure that 5V is measured at the Output terminals	Multimeter reads 5V at Output Terminals (10% Deviation Allowed)	
	Relay Board	Power On	Using the PSU or any other 5V power supply that can be connected to the Board's DC input, power the board and ensure the LED indicator powered on.	LED On	
			Verify using a DMM that the +5V pin of the ESP8266 chip reads 5 Volt	DMM measures 5V (10% Deviation allowed)	
	Relay Switches	Operational	Instructions TBD	Relay is Closed	
			Instructions TBD	Relay is Opened	

Table 25 Continued

Product Name	Component Name	Test Type	Testing Instructions (Using all Safety Precautions)	Expected Results	Pass/Fail
Wireless Smart Outlet Components	Current Sensor	Power On	Power the Current sensor using a 5V Power Supply, verify sensor LED is ON	LED is ON	
	ESP8266	Operational	Power the Current sensor with a 5V PSU. Connect the the Hot wire of an AC lamp's cord to the Hot terminal and the neutral wire to the neutral terminal. Leave the cord unplugged and verify the lamp is OFF. Use a DMM and measure the Voltage out, verify V _{out} is near 0.	V _{out} is ~ 0V, Lamp if Off	
		Logical	Plug the cord in and verify the Lamp is on. Test V _{out} and verify the sensor is measuring a voltage.	V _{out} is > 0, Lamp is On	
Wireless Smart Outlet (Assembled)	Prototype	Operational	With Relay in On position. Install the Wall Outlet. Plug in any device that requires less than 15A and ensure device is operational	Relay is On, Plugged in device is On	
		Logical	Energy Monitoring instructions TBD	Web Application present record of current measurements	

Table 25 Continued.

Product Name	Component Name	Test Type	Testing Instructions (Using all Safety Precautions)	Expected Results	Pass/ Fail
Wireless Smart Outlet (Assembled)	Prototype		Using the Web App Toggle the Outlet On	Web Application displays Outlet is On, Plugged-In Device is ON	
			Using the Web App Toggle the Outlet Off	Web Application displays Outlet is Off, Plugged-In device is Off	
			Set Schedule to turn ON Outlet	Outlet is On at scheduled time	
			Set Schedule to turn OFF Outlet	Outlet is Turned off at scheduled time.	

6.2. Software Testing

An essential step in any project is the testing portion. Because we want our project to be pleasant to use by our end-users, we have dedicated large amounts of time in this phase. Also, because we are offering a web application, we need our product to conform with certain standards of the industry. Such standards were discussed in Section 4.1. Similarly, testing standards also exist, and they were followed during the tests performed by us.

The testing plan for our project will encompass three primary stages: Unit Testing, Integration Testing, and System Testing. This will help to ensure that potential issues at every level of development are caught and weeded out in a timely manner and assist in the process of isolating the exact nature of software bugs, which in turn will save significant time in diagnosing its cause and finding a solution. The specific testing plans for each phase are outlined below and will be applied more or less identically across every major software component of the system in question.

Unit testing will be carried out by writing and running written tests for major functions and modules within a given software system. These tests will be automated and designed with consideration for the listed design goals of that function or module. Though the process of writing these tests will take time, there will be a net benefit of time saved once they are implemented into the design process, as they will allow the functionality of individual components of the software to be verified in a clear pass/fail manner. Once individual functions and classes have been isolated, an exacting and clear-cut testing plan for each component of a given piece of software will be created and used as a baseline for the writing of unit tests and the evaluation of their results. Once unit testing has been verified to produce adequate results, integration testing can be carried out.

The purpose of integration testing is to identify potential faults in the interactions between individual units. Although each unit may function properly on its own, unforeseen issues may arise from the communication between those individual units. To that end, carrying out integration testing helps to identify these issues by ensuring that the units are not only tested in a vacuum, but also tested together. Integration testing need only be carried out between units which are directly related to one another, I.E. two functions or classes which are dependent on and communicate with one another during regular operation of the software. Once integration testing is complete, system testing will be carried out.

Carrying out system testing will work to ensure that the given pieces of software, as a whole, carry out their proper functions, and will endeavor to find and isolate issues which arise at the highest level of integration between all the myriad components of the system itself. System testing, in this context, will also server to verify that the interconnectivity between the various pieces of software which make up the smart home system as a whole is functioning properly, whether that happens to be the connection between the central hub and the server or the connection between the various modules which make up the in-home component of the system and the hub itself.

The structure of this testing plan outlines why it is important for rapid-prototyping to occur at some point during the development stages, as interconnectivity is only tested at the highest level of testing when it comes to the verification of the functionality of the final product. The viability of the networking scheme and other related interconnectivity *must* be verified at the earlier stages of development with proof-of-concept prototypes so as to ensure that any potential incompatibilities between separate pieces of hardware are identified early and that proper workarounds or replacements can be devised.

6.2.1. Integrated Development Environments

Integrated Development Environments (IDEs) were not only used to aid in the development of the code used in this project, but also in the aid of testing such code. We utilized Visual Studio Code as the software of choice to perform such tests.

6.2.2. Website Testing

In order to test the functionality of the web application for our project, we divided the tests in key categories: account creation, account authentication, and account management.

One of the first tests performed for our web app website was the creation of an account. In order to do so, we create a dummy account with fictitious information to check if doing so would correctly populate our database with the same information. Upon doing so, we also checked if after the successful creation of the account if it was possible for such user to login into our system. Figure 64 shows the data we used to create a new user.

Sign up

Username*

TestUser1

Required. 150 characters or fewer. Letters, digits and @/./+/-/_ only.

First name

Test

Last name

User

Email*

testuser@hsas.site

Password*

• Your password can't be too similar to your other personal information.

- Your password must contain at least 8 characters.
- Your password can't be a commonly used password.
- Your password can't be entirely numeric.

Password confirmation*

Enter the same password as before, for verification.

SUBMIT

Already Have an Account? [Sign In](#)

Figure 64. Test User Registration Information

Figure 65 show that same information in our database, and finally figure 66 shows that user logged in in our system, therefore confirming the success of our test.

```

_id: ObjectId("5d35d7de4b6455aad1e97dca")
id: 3
password: "pbkdf2_sha256$150000$K3Tv7iuwebu/
last_login: 2019-07-22T15:40:59.142+00:00
is_superuser: false
username: "TestUser1"
first_name: "Test"
last_name: "User"
email: "testuser@hsas.site"
is_staff: false
is_active: true
date_joined: 2019-07-22T15:35:56.728+00:00

```

Figure 65. Test User Information in Database

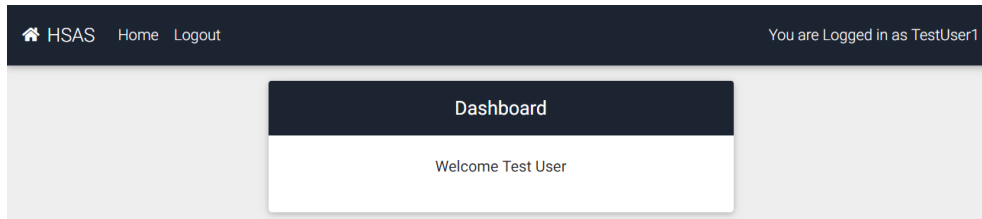

Figure 66. Confirmation of Test User Log In

Another test that can also be performed is the password reset test. On figure x we can see the flowchart of the actions the user needs to take in order to receive a new password in case the old one has been lost or forgotten. This feature is implemented in the web app and the following figures demonstrate the process with the information of a test user, the same one created in the previous test.

When the user navigates to the login page, they have the option to click the “forgot password” link. The user will then be redirected to a form where they can input the email, as seen in figure 67, registered to their account.

A screenshot of a 'Password Reset' form. The form has a dark blue header with the text 'Password Reset'. Below the header, it says 'Please enter your email below'. There is an input field labeled 'Email*' containing the text 'testuser@hsas.site'. Below the input field is a blue button with the text 'SUBMIT'.

Figure 67. First Step for Password Reset

After successful verification of the associated registered user email address, a success message is displayed directing the user to check their email box, as seen in figure 68.

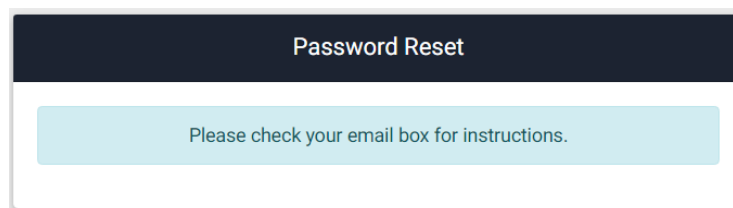

Figure 68. Second Step for Password Reset

As seen in the email message in figure 69, the user receives a link to reset their password. This link is securely generated by our back-end framework Django and is unique to each password reset request. It is also important to note, that since this test was made while the system was still being developed, the information displayed contains localhost addresses as opposed to our actual domain name and website name. This will be implemented for the final version of our system, and this document will be updated accordingly.

no-reply@hsas.site

Password reset on 127.0.0.1:8000

To Test User

You're receiving this email because you requested a password reset for your user account at 127.0.0.1:8000.

Please go to the following page and choose a new password:

<http://127.0.0.1:8000/accounts/reset/Mw/58b-2736e08bb2fb8ef4c177/>

Your username, in case you've forgotten: TestUser1

Thanks for using our site!

Figure 69. Third Step for Password Reset

When the user navigates to the link sent to them, they will be prompted to create a new password to be used with their account. In figure 70, the user enters a new password and can then login with their new credentials. We can see the confirmation in figure 71.

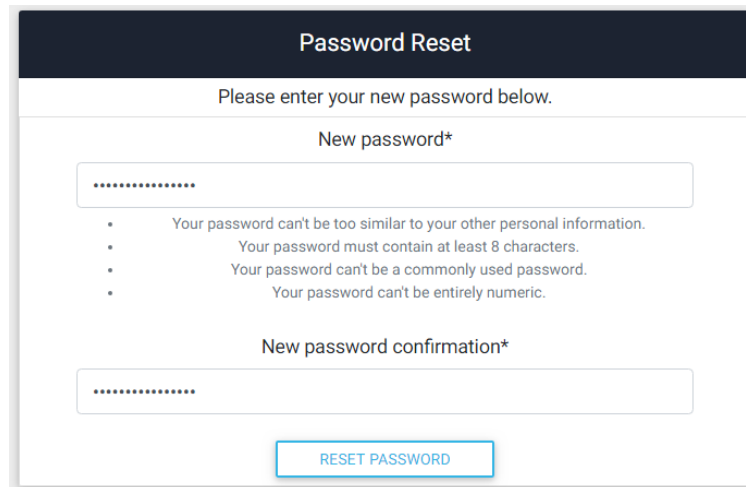

The screenshot shows a web form titled "Password Reset". Below the title is the instruction "Please enter your new password below." The form contains two input fields: "New password*" and "New password confirmation*", both filled with dots. Below the first input field is a list of four password requirements:

- Your password can't be too similar to your other personal information.
- Your password must contain at least 8 characters.
- Your password can't be a commonly used password.
- Your password can't be entirely numeric.

At the bottom of the form is a button labeled "RESET PASSWORD".

Figure 70. Fourth Step for Password Reset

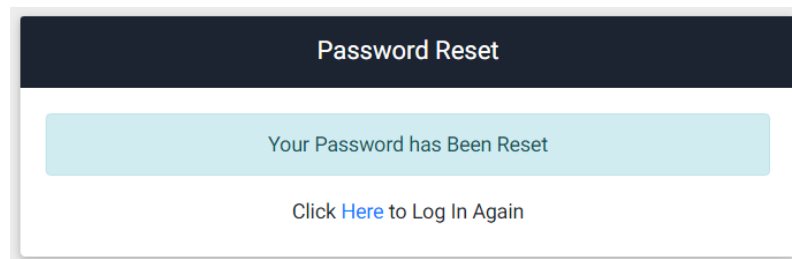

The screenshot shows a confirmation page titled "Password Reset". A large light blue box contains the message "Your Password has Been Reset". Below this box is a link that says "Click [Here](#) to Log In Again".

Figure 71. Fifth Step for Password Reset

If the user tries to login with their new credentials, they will be able to successfully do so, as seen in figure 72.

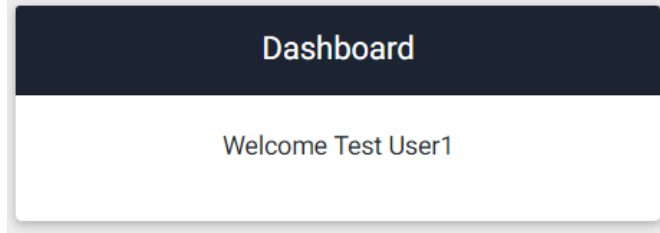

Figure 72. Successful Login After Password Reset

With the steps described above, the user is able to successfully reset their password in case it is lost or forgotten. The system behind the process described is discussed in Section 5.2.4.

6.3. Optics and Sensor Testing

The silicon infrared photodiode for fire detection was tested at varying distances and with a lens. Our first procedure was to attach a 5-volt power supply to the diode circuit and a multi-meter to the DC output. A lighter flame was put in front of the diode at one-foot intervals up to five feet. This was repeated with the N-BK7 lens present in front of the diode. The entire experiment was repeated using a propane torch instead of a lighter to simulate a larger flame. All output voltages were recorded.

Table 26 Small Flame Detection

Distance (Inches)	Lens Not Present (Output Voltage Abs. Value)	Lens Present
3	5V	N/A
6	5V	N/A
9	5V	N/A
12	5V	N/A
15	5V	N/A
18	5V	N/A
21	5V	N/A
24	5V	N/A
27	0V	N/A
30	0V	N/A
33	0V	N/A
36	0V	N/A
60	0V	N/A

Table 26 shows that the DC output voltage is either on at five volts or off at nothing. During our experiment we observed that the detection angle is pivotal in consistent testing because the silicon photodiode is sensitive to radiation which is directly normal to it but has increasingly diminishing range as we increase the angle of incidence. This observation will lead to more testing on the effect the angle of incidence of the fire source on the photodiode has on both the AC and the DC output. The specifications of the silicon photodiode state that it has a range of up to two feet and we have seen this is true for the DC response in smaller angles of incidence.

Figure 73 shows the AC output voltage of the photodiode compared with the distance of the flame. We can see there is an exponential decay in the AC output voltage over distance and this is an expected response due to the exponentially decreasing input signal of the flame over distance. We can see this result is consistent with the spherical wave equation for the phasor form of a wave which is detailed in Equation 1, in Figure 44.

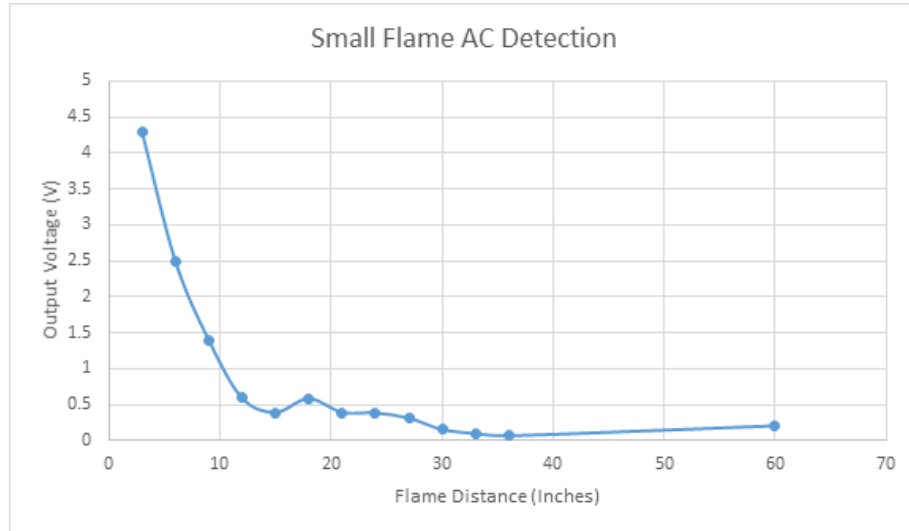

Figure 73. Small Flame Detection AC Output Without Lens Present

$$\hat{f}(\mathbf{r}) = \frac{a}{ir} \exp \{ ikr \} .$$

Figure 74. Equation 1

Equation taken from: <https://bit.ly/2FXKgcN>

Table 27 Large Flame Detection DC Output

Distance (Inches)	Lens Not Present (Output Voltage)	Lens Present
3	0V	N/A
6	0V	N/A
9	0V	N/A
12	0V	N/A
15	0V	N/A
18	0V	N/A
21	0V	N/A
24	0V	N/A
27	0V	N/A
30	0V	N/A
33	0V	N/A
36	0V	N/A
60	0V	N/A

The NIR photodiode also has an AC output that we may utilize along with software to trigger positive outputs. An oscilloscope was attached to the NIR photodiode’s AC output and the previous test was performed with the diode. The following waveforms were observed from the AC and DC outputs:

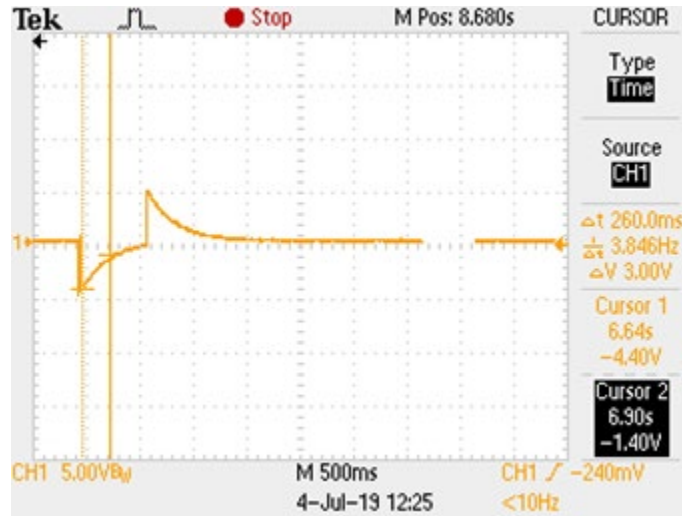

Figure 75. NIR Sensor DC Response Rise/Fall Time

Figure 75 shows the DC response of the NIR sensor taken at three inches. We observe the negative five-volt output when the flame is initially sparked and a decay as the flame is kept. A positive five-volt output was recorded when the flame was put out. The figure shows the rise and fall times of the DC output to be approximately 260 milliseconds. This is the standard response to any fires directly within the center of the sensor’s field of view. We’ve observed that the sensor is highly sensitive to the detection angle and that angles over twenty degrees can lower the input signal drastically and even cause the sensor to not detect the fire. Fires on the edge of the sensor’s field of view will give a DC output that resembles an impulse function as seen in Figure 76 or possibly not respond to the fire at all.

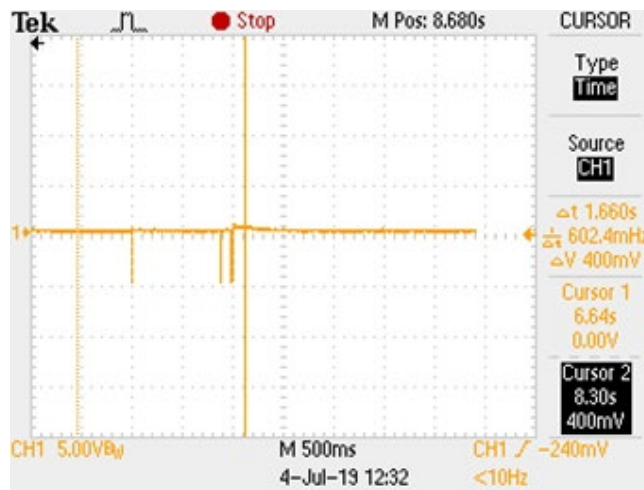

Figure 76. NIR Sensor DC Response for FOV Edge Detection



Figure 77. NIR Sensor AC Response at 3 Inches

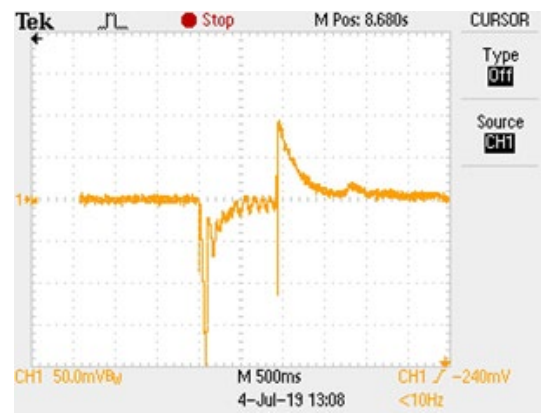

Figure 78. NIR Sensor AC Response at 60 Inches

We've included the oscilloscope images of the AC output for the small flame testing for both three and sixty inches to show that the shape is consistent for any flame source in figures 77 and 78. We can see that the initial trigger is a negative voltage much like that of the DC response, but there is consistent modulation due to the wave effects and inconsistencies in the source.

During testing we noticed that the photodiode had varying responses to different noise sources. We will continue testing on indoor light sources, hot materials, and the sun in later portions of testing. We've included the noise from human blackbody radiation distances of both three and twelve inches in Figures 79 and 80. The noise recorded is comparable to some of our measurements around three feet, so we will have to amplify our input flame signal to stop false triggers. The initial testing occurred on July 3rd, 2019 at 2500 North Orange Blossom Trail in the production floor of L3 Technologies.

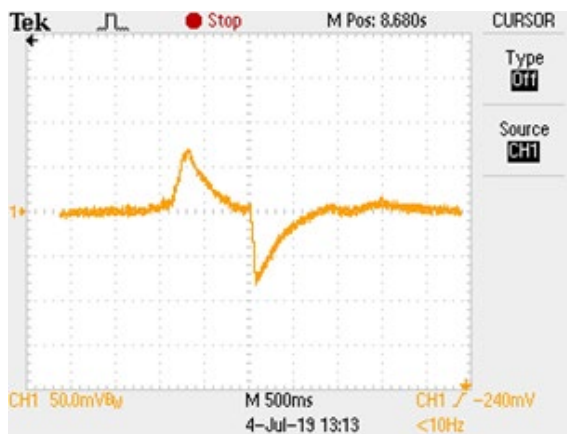

Figure 80. Human Noise at 3 Inches



Figure 79. Human Noise at 12 Inches

The passive infrared detector for motion sensing was characterized in terms of proximity, reset time, and responsivity to objects moving within the sensor's proximity as well as into or out of the sensor's proximity. We attached a power supply to the diode and attached a multi-meter to the diode's DC output. We then mounted the diode to the edge of a room and started with the proximity testing. We determined the field of view for the sensor by walking into the sensor's proximity from the side and recording when the sensor gave a positive output. We then used this field to find the furthest point that the diode will detect. Someone walked into the field of view at intervals of two feet up to twenty-five feet.

A large challenge with the passive infrared detector is its inability to discern motion within the proximity that isn't moving into or out of the field. We tested the chance of motion detection within the field by having one person stand directly in the middle of one portion of the sensor and wave at the diode. We repeated these many times and recorded the results to determine how likely it is that the sensor will detect motion within the field.

Table 28 Passive Infrared Photodiode Operating Specifications

Specification	Value
Proximity	Up to 6 meters
Field of view	About 100 degrees
Operating voltage	12V
Output Voltage	3V
Period	8.7 Seconds
Maximum Detection Range	20 feet

We measured the actual blockade time for the PIR photodiode by consistently moving within the field of view and taking the difference between the first two triggers. We can see from Figure 81 that the period is 8.7 seconds and the initial trigger voltage is a positive 3.7V output.



Figure 81. PIR Output for Consistent Triggering Measuring Period

We will continue with testing of the PIR sensors for field of view and small motion detection. The field of view test will be simple: one of us will move into the sensor's center of field and then he will move outward by one-foot intervals and we will find where the

sensor no longer sees him. We will then repeat the test by moving backwards a few feet and repeating measurements. This will help us characterize the sensor's field of view.

The NIR sensors will need to be tested with a larger flame and a lens present. We will also test the NIR sensors for field of view and false detections. The false detection testing will use several different noise sources to trigger false detection on both the AC and DC outputs of the sensor. We will start with our main noise source: the sun. The sensor will be covered by a box and then it will be suddenly exposed to sunlight as the box is removed. This will show us if our product can be used in the sun or by windows. Our next noise source we will use is a flickering lamp. We will put our sensor within a foot of a lamp and repeatedly turn it on and off to try to trigger false detections through house lighting.

6.3.1. Secondary Sensor Testing

After initial testing was concluded with both the PIR and NIR sensors being tested for output signals and basic functionalities. Further testing was conducted in a private domicile at 3805 Stonefield Drive for noise sources, potentiometer tuning, and different input voltage levels. The lens and full system testing will be conducted in the final section. We recognized that the sun could pose a potential threat to our fire detection system due to its blackbody spectrum overlapping our NIR sensor's spectrum, so we decided to design a test to see if the sun is capable of causing false triggers. We set up our oscilloscope, NIR photodiode, and power supply by a window with a curtain and we moved the curtain to allow the sunlight to be incident to the photodiode. We did this for both the AC and DC outputs. Figure 82 shows the AC response of the photodiode. We can see that there is a trigger which will cause issues if we are going to use the AC output. The DC response for the NIR photodiode was consistent and offered no triggers for any amount of sunlight. There are a few options to deal with this issue: We can utilize a bandpass filter to only allow light around 940nm in which is absorbed in the atmosphere, we can place the sensors away from any windows or out of direct line of sight of the sun, or we can use the DC response for our project to stop any false triggers.

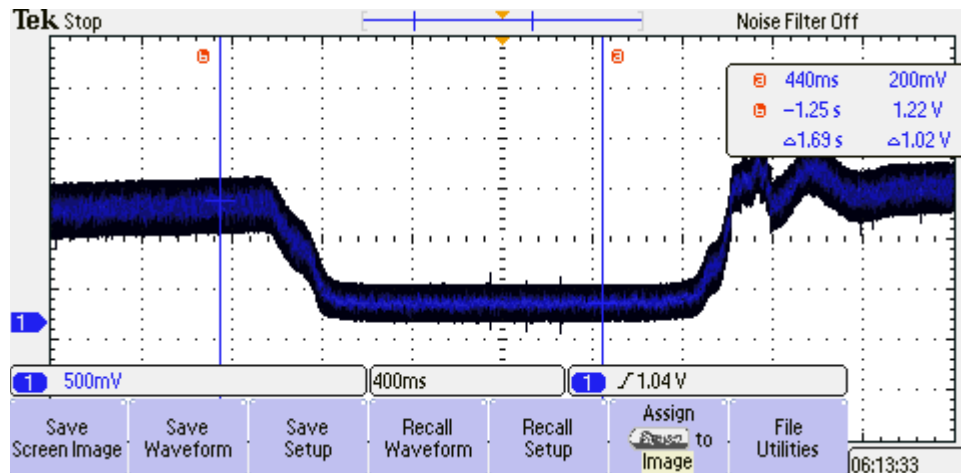

Figure 82. AC Response to the Sun

Once we tested to see if the sun was a noise source of interest we quickly realized that our lighting system could pose possible challenges to the fire detection system, so we tested to

see the effect an incident 60-Watt lightbulb had on the AC and DC responses of the NIR photodiode. Figure 83 shows the AC response of the NIR photodiode when we turned on a light directly 3 inches above it. We can see that there is an instantaneous trigger and the signal changes by over a full volt. This poses yet another challenge for our fire detector because this means that the indoor lighting could affect the trigger times of the fire detector if we use an AC response. Using a filter could help solve this issue as well as pointing the detector downward to avoid incident ambient light getting onto the photodiode and causing it to give off a false trigger to the system. There was no DC response to the light flickering so using the DC output may be the best solution for now.

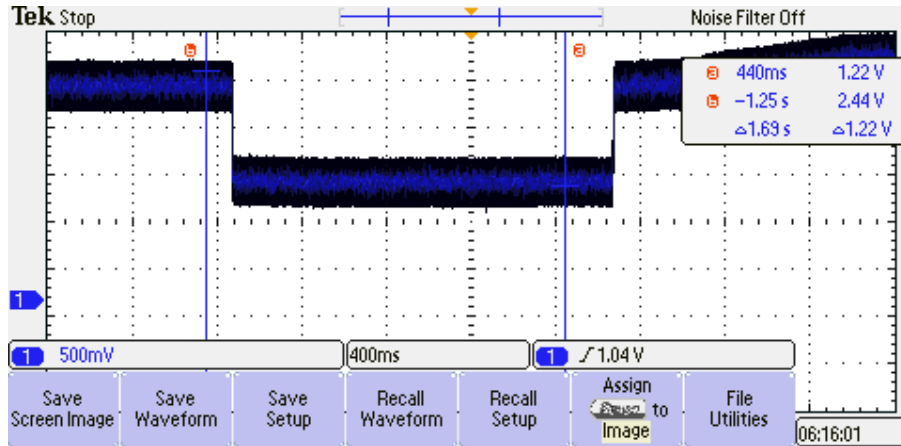

Figure 83. AC Response to Light source

We looked at our waveforms from the initial testing and realized that the potentiometers weren't being correctly tuned for optimal testing results due to the output waveforms. We adjusted the potentiometers on our units, and we were able to refine the resulting waveforms into more consistent voltages. We also found that the sensors gave a much better response time after tuning the potentiometers. Figure 84 shows a DC response of the NIR sensor to a regular fire. The figure shows a remarkably uniform square wave which is exceedingly easy for any central control system to identify and respond to.

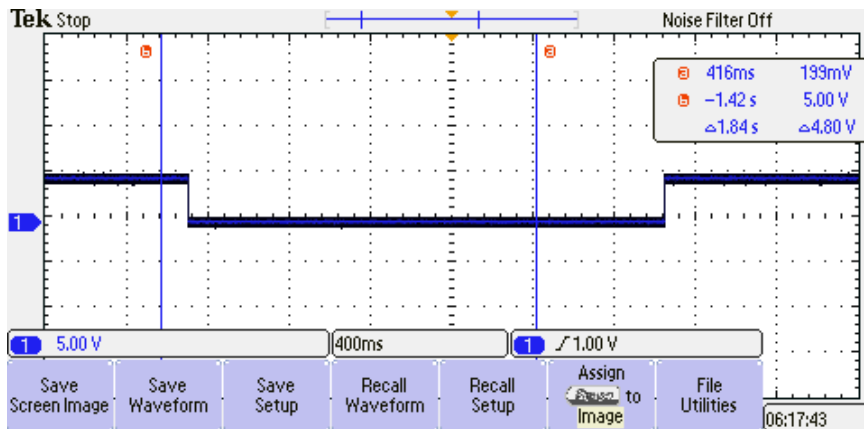

Figure 84. DC Response of NIR Sensor with Tuned Potentiometer

The large flame testing was completed, and it held surprising results compared with what we had originally imagined. We predicted that the larger propane torch flame would allow

the NIR photodiode to detect it from much further away due to the higher heat and size of the flame. We've found out that the propane torch doesn't trigger the sensor at all. We think this may be because the flame is more directed due to the compressed nature of the propane tank torch or even due to the unique burning properties of propane. This has little effect on the actual effectiveness of our fire detector because we're trying to detect uncontrolled fires and propane torches are controlled.

The propane torch experiment made us consider the possibility of a hot object triggering a response from our NIR photodiodes, so we decided to design an experiment to measure the AC and DC responses of the photodiodes from hot sources. We heated a piece of quartz to over 1,000 degrees Fahrenheit and then moved it in front of our sensor for analysis. Figures 85 and 86 show the AC and DC responses for the heated quartz and both show that the sensor triggered. The AC response was detectable from half a foot away and the DC response was from just a few inches, so the DC response has a higher trigger threshold. This means the sensors can see when something is exceedingly hot, so this adds to the safety of the device.

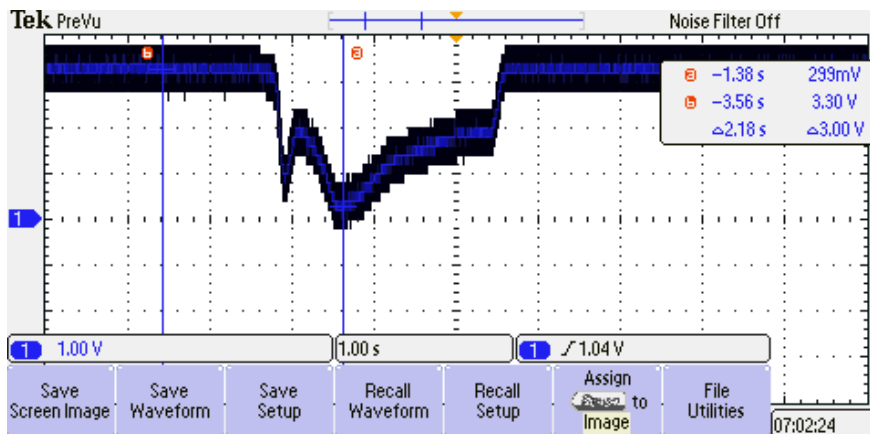

Figure 85. AC Output Response of NIR Sensor for Heated Quartz

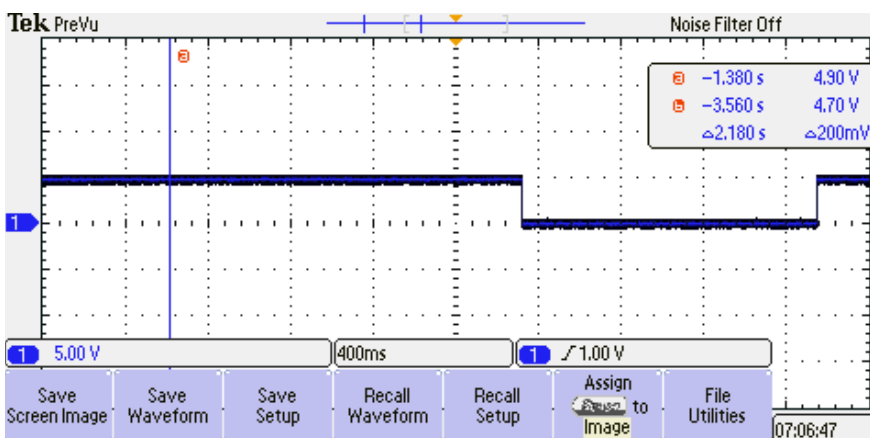

Figure 86. DC Output Response of NIR Sensor for Heated Quartz

We are going to be operating this device in the kitchen, so we have to make sure that the temperature of cooking isn't high enough to cause the fire detector to trigger. We will

observe the temperature range of 300-400 degrees Fahrenheit in the final testing to evaluate whether our system can detect objects in that temperature range.

We readjusted our potentiometers in both sensors and realized that we could get a continuous response rather than an impulse response. This will allow the NIR sensor to recognize actual fires with less error due to noise sources which may quickly disappear. A minimum signal time could be implemented into the system to detect shorter signals that may not be fire. Figure 87 shows the response of the PIR sensor with adjusted potentiometers. We see that the output waveform is a constant 3.32V when the sensor is triggered and 40mV when the sensor is off. Figure 88 shows the shape of the NIR sensor's input signal at 6V which maintains the same shape as the signal at 5V.

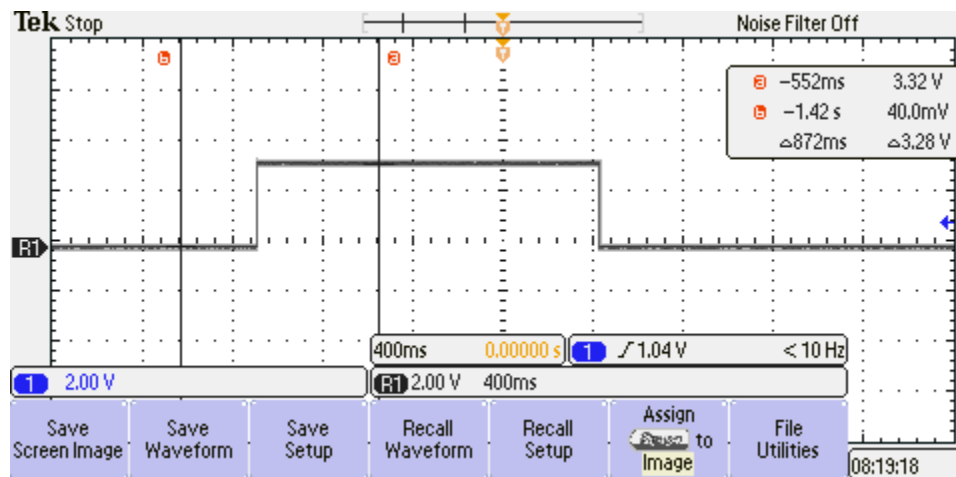

Figure 87. PIR Sensor Output Voltage with Adjusted Potentiometer

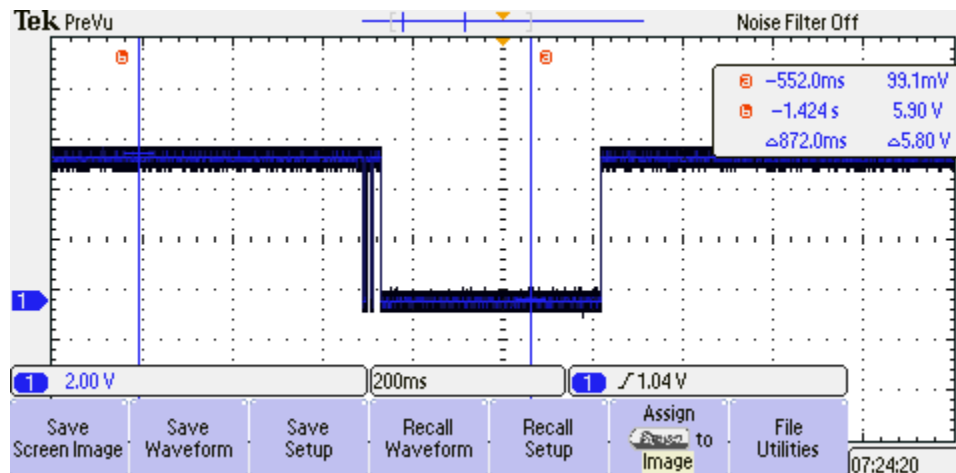

Figure 88. NIR Sensor Operating with 6V Input Voltage

Our photodiodes will require a power source around 5V, but to keep things simple we observed its operation at 6V. This would make it simple for us to power them since we could just use 4 AA batteries. Figure 88 shows the DC output of the NIR photodiode

operating at 6V. We see that the output voltage is 5.9V when it is off and when it's turned on it goes to 99mV. We will more than likely utilize a 5V source for power, but this allows us to see that operation is still normal with a 6V input. It was also observed that the range increased slightly when we used a 6V input voltage.

7. User Manual

In the following sections we provide the user with instructions on how to use the main features of our system.

7.1. Account Management

7.1.1. User Registration

When the user first sets up their system, they will need access to our web application. In order to do so they will need a registered account with our system. To do so, the user can take the following steps:

1. From a web browser, navigate to <http://hsas.site>
2. Click on “Web Application”
3. Click “Register” on the top navigation bar
4. Alternatively, the user can login with their social account
5. Fill out the form with their information
6. After submitting the form, the user will be automatically logged in

7.1.2. Profile Management

The user is also able to see and edit the information on their profile. This is useful in case they need to update any information provided when registering into the system or checking if the information is correct. Following the steps below the user will be able to do so.

1. From a web browser, navigate to <http://hsas.site>
2. Login into the system
3. On the top navigation bar, click “View Profile”

If the user wishes to edit the information on their profile. They can take the following steps:

1. Click “Edit Profile”
2. A screen with their current information is displayed
3. The user can now edit the fields with new information
4. Click “Save”
5. The user is redirected to the “View Profile” page with the updated information

8. Future Improvements

This section will detail the technology that could be used to improve the quality of our project if we had more resources such as money or time.

8.1. Fire Detection Improvements

Our fire detector currently consists of an infrared photodiode on an embedded circuit which amplifies the output signal given by the diode for easy detection. We've demonstrated the

shortcomings of this sensor such as range, field of view, and false detections such as sunlight or room lighting. This section will cover better detection methods than our current photodiode can provide.

The infrared photodiode is only sensitive to wavelengths between 600 and 1100 nanometers, but in our optics research section we noted several examples of ultraviolet sensors also being able to detect fire. There is one ultraviolet emission from fire which we could use for detection that is emitted from the CH band at 314 and 390 nanometers as well as radiation from the OH band at 306 nanometers [3]. Figure 89 shows a low-cost ultraviolet photodiode which is embedded on an amplifying circuit and could be used to improve the accuracy of the fire detector. This model has an operating bandwidth of 280 to 390 nanometers and an operating input voltage between 3.3V and 5V.

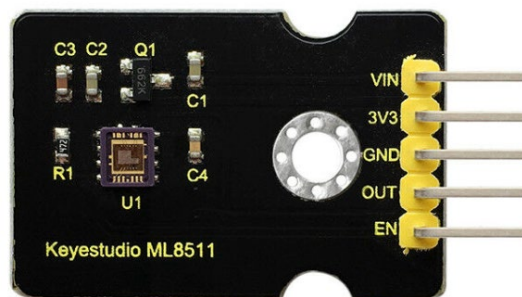

Figure 89. Ultraviolet Photodiode for Flame Detection

Source: <https://ebay.to/2STBuSp>

This module could be utilized in one of two ways. The first way to utilize this ultraviolet photodiode in our fire detection system is to mount it onto the inside wall of the sensor housing and use a dichroic mirror to reflect the ultraviolet radiation towards the sensor. The dichroic mirror would need to be placed half an inch above the baseplate to allow the incident radiation to travel one focal length to the sensor. This method would be effective in making the fire detector one concise unit capable of both fire detection and false sound detection which would improve the accuracy of the unit. Dichroic mirrors can cost around \$100 so it is a rather costly solution. N-BK7 is highly reflective of wavelengths below 350 nanometers, so the ultraviolet detector will only have incident radiation from the CH band at 390 nanometers since the radiation from the OH band at 306 nanometers and the radiation from the CH band at 314 nanometers will be reflected by the lens. This could be solved by utilizing a lens made of fused silica because the transmission spectrum of fused silica is between 160 nanometers and 2 microns. Figure 90 shows the transmission spectrum of fused silica and we can see that transmission between 300 nanometers and 1.1 microns is just above 90% which will allow both the incident infrared radiation and the incident ultraviolet radiation to be transmitted onto the sensors.

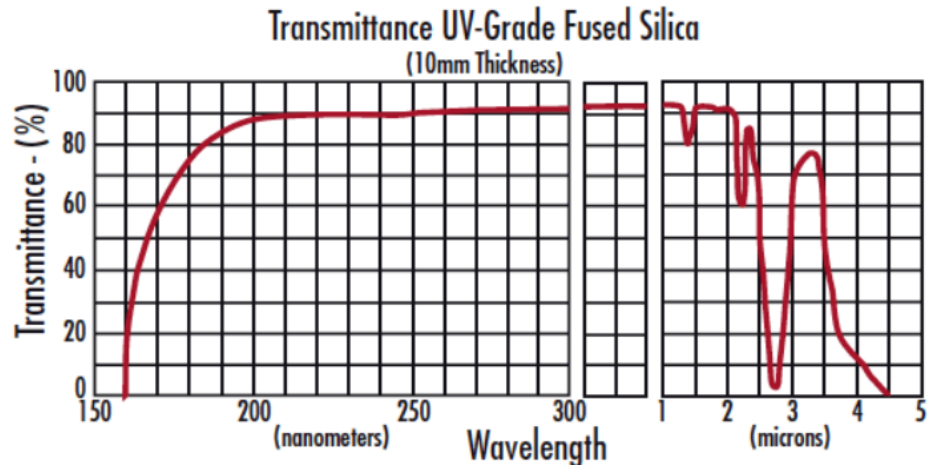

Figure 90. Transmission Spectrum of Fused Silica

Source: <https://bit.ly/2YCBxHn>

The second method of utilizing this module is by having two lenses beside each other on one sensor housing with each focusing directly onto a sensor. This would allow radiation from both the CH and OH bands to be transmitted onto the ultraviolet photodiode because we could choose two separate lenses. This method would be much cheaper than the former because only an extra lens would be added to the system. This type of system could fail to detect fires if it occurs within the field of view of one photodiode but not in the other photodiodes field of view. This is because both systems will be independent of each other due to the incident radiation being different for both lenses.

The NIR photodiode cannot detect peak emissions of flame which occurs at 4.3 microns due to the emission of carbon dioxide [3]. A more accurate device which is much more expensive than an infrared photodiode is an infrared CCD camera. One particular CCD camera which is praised as being relatively low cost can detect a large bandwidth which begins in the ultraviolet spectrum at 250 nanometers and ends in the mid-infrared spectrum at 12 microns. This makes the system extremely accurate because it can be triggered easily by the 4.3 microns radiation and it can confirm whether the source was fire by correlating it with the 390 nanometers emission from the CH band [3]. Not only does this allow the system to have a large increase in both range and accuracy, but it also allows users to have the choice of physically taking pictures and videos of the observed fire.

The fire detector could also be improved by utilizing a photodiode which is sensitive to mid-wave infrared radiation along with our NIR photodiode. The model Lms49PD-05 series photodiode offered by lmsnt.com can detect mid-wave infrared radiation between 2.8 and 4.9 micrometers which contains both peak emissions at 4.3 microns from the CO₂ emission and 2.7 microns from the H₂O and CO₂ emissions. Figure 91 shows the typical spectral response of the Lms49PD-05 series to radiation within its operational bandwidth. We can see that the photosensitivity is high for both our expected emission peaks at 0.8 amperes per watt at 2.9 microns and about 1 ampere per watt at 4.3 microns.

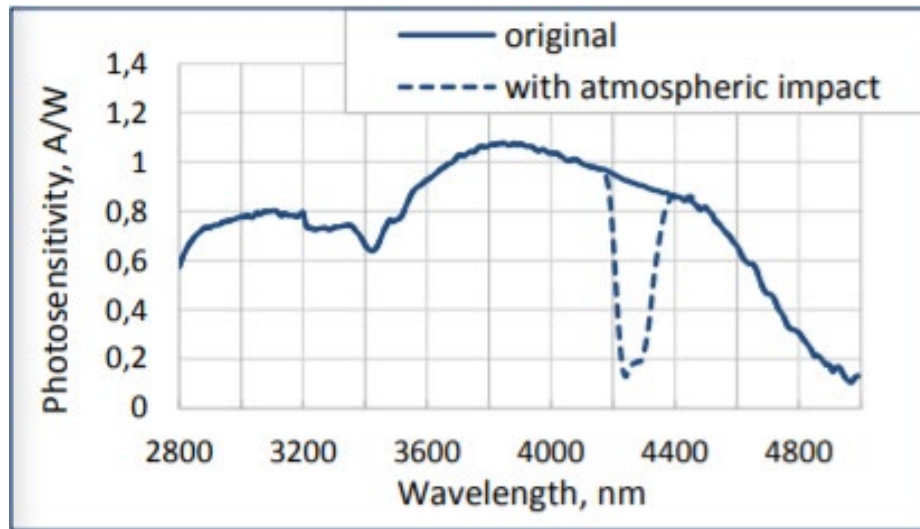

Figure 91. Lms49PD-05 Series Spectral Response of Operational Bandwidth

Source: <https://bit.ly/2K9F4oK>

This type of photodiode is expensive and would also require a lens capable of transmitting mid-wave infrared radiation with small losses. A sodium-chloride lens would be a good candidate for this application because it will transmit radiation up to 10 microns with over a 90% transmission rate. This type of lens is also relatively inexpensive.

9. Administrative Content

9.1. Milestone Discussion

We decided from the beginning of the semester that we'd meet every Thursday at seven p.m. at the UCF library to discuss current progress and future goals. Table 29 details all of our goals and milestones.

Table 29 Milestones

Milestone	Completion Date
First Group Meeting	5/13/2019
Brainstorm Ideas	5/19/2019
Decide on Idea	5/24/2019
Second Group Meeting	5/21/2019
Finish Divide and Conquer	5/27/2019
Meeting with Professor	5/28/2019
Third Group Meeting	5/30/2019
Finish Divide and Conquer 2.0	6/7/2019
Fourth Group Meeting	6/7/2019

Table 29 Continued

Complete Table of Contents	6/9/2019
Fifth Group Meeting	6/13/2019
Initial Sensor Testing	7/3/2019
Sixth Group Meeting	6/27/2019
Seventh Group Meeting	7/5/2019
Finish 50% Draft	7/7/2019
Eight Group Meeting	7/18/2019
Secondary Sensor Testing	7/19/2019
Ninth Group Meeting	7/25/2019

9.2. Division of Responsibilities

Each member of the group will have an area of the project to be responsible for. However, we all will contribute to each other's work if needed and if help is requested. Some areas also will function together and therefore we will work in this specific section at the same time.

Table 30 Division of Responsibilities

Area	Person Responsible
Sensors	Avery Stevenson
Outlets, Switches and AC Control	Felix Henriquez
Communication between Devices and Back End	Matthew Allen
Web Server / User Interaction (Back End)	Guilherme Costa

9.3. Budget Discussion

As of the date we are writing this document, our group does not have a sponsor. Therefore, we are funding the project as a group. In this section we have provided a table to the reader with the expenses we have planned for this project.

Table 31 Budget Allocation

Parts	Expected Costs
Motion Sensor System	\$10
Thermal Sensor System	\$25
Micro Controller	\$35
Security Camera	\$10

Table 31 Continued

PCB	\$30
Door Lock System	\$20
Outlet System	\$35
Backup Battery System	\$30
Web Server	\$45
Domain	\$2.5
Total	\$242.5

Appendices

References

- [1] “An Illustration of Making a Home Automation System Using Raspberry Pi and PIR Sensor.” *2018 International Conference on Intelligent Circuits and Systems (ICICS), Intelligent Circuits and Systems (ICICS), 2018 International Conference on, ICICS*, 2018, p. 439. *EBSCOhost*, doi:10.1109/ICICS.2018.00095.
- [2] Gunawan, Teddy Surya1, [tsgunawan@iium.edu. m.](mailto:tsgunawan@iium.edu.m), et al. “Performance Evaluation of Smart Home System Using Internet of Things.” *International Journal of Electrical & Computer Engineering (2088-8708)*, vol. 8, no. 1, Feb. 2018, pp. 400–411. *EBSCOhost*, doi:10.11591/ijece.v8i1.pp400-411.
- [3] Le Maoult, Y., et al. “Fire Detection: A New Approach Based on a Low Cost CCD Camera in the Near Infrared.” *Process Safety and Environmental Protection*, vol. 85, no. 3, Jan. 2007, pp. 193–206. *EBSCOhost*, doi:10.1205/psep06035.
- [4] Chin-Chi Cheng, and Dasheng Lee. “Enabling Smart Air Conditioning by Sensor Development: A Review.” *Sensors (14248220)*, vol. 16, no. 12, Dec. 2016, p. 2028. *EBSCOhost*, search.ebscohost.com/login.aspx?direct=true&db=edb&AN=120375836&site=eds-live&scope=site.
- [5] Le Maoult, Y., et al. “Fire Detection: A New Approach Based on a Low Cost CCD Camera in the Near Infrared.” *Process Safety and Environmental Protection*, vol. 85, no. 3, Jan. 2007, pp. 193–206. *EBSCOhost*, doi:10.1205/psep06035.
- [6] “Usage Statistics of Apache.” *W3Techs*, w3techs.com/technologies/details/ws-apache/all/all.
- [6] “Usage Statistics of Apache.” *W3Techs*, w3techs.com/technologies/details/ws-apache/all/all.
- [7] “Usage Statistics of Nginx.” *W3Techs*, w3techs.com/technologies/details/ws-nginx/all/all.
- [8] “Documentation.” *Django*, docs.djangoproject.com/en/2.2/howto/static-files/.
- [9] “Brute Forcing Wi-Fi-Protected Setup” https://sviehb.files.wordpress.com/2011/12/viehboeck_wps.pdf
- [10] “Download Raspbian for Raspberry Pi” <https://www.raspberrypi.org/downloads/raspbian/>
- [11] <https://www.raspberrypi.org/products/raspberry-pi-3-model-b-plus/>

Copyright Permissions

For every image or code used in the project that was not of our own productions was utilized with the required permission upon requests shown below.

Material Design Bootstrap Web Framework. As displayed on the website:

Copyright (c) 2019 MDBootstrap.com

THE SOFTWARE IS PROVIDED "AS IS", WITHOUT WARRANTY OF ANY KIND, EXPRESS OR IMPLIED, INCLUDING BUT NOT LIMITED TO

THE WARRANTIES OF MERCHANTABILITY, FITNESS FOR A PARTICULAR PURPOSE AND NONINFRINGEMENT. IN NO EVENT SHALL THE AUTHORS OR COPYRIGHT HOLDERS BE LIABLE FOR ANY CLAIM, DAMAGES OR OTHER LIABILITY, WHETHER IN AN ACTION OF CONTRACT, TORT OR OTHERWISE, ARISING FROM, OUT OF OR IN CONNECTION WITH THE SOFTWARE OR THE USE OR OTHER DEALINGS IN THE SOFTWARE.