



PARK SHARK

GROUP D

Keegan Conway, CpE

Travis Bangs, CpE

Marcelino Galarza, CpE

Beatriz Jimenez, EE

Motivation

- UCF's current system is extremely inaccurate
 - Uses sensors at the entrance to each garage
 - Online information not useful for finding parking
 - No information on where parking is available



Goals and Objectives

- Accurate parking/floor availability
- Display information simply and effectively
- Multi-sensor approach
- Inexpensive

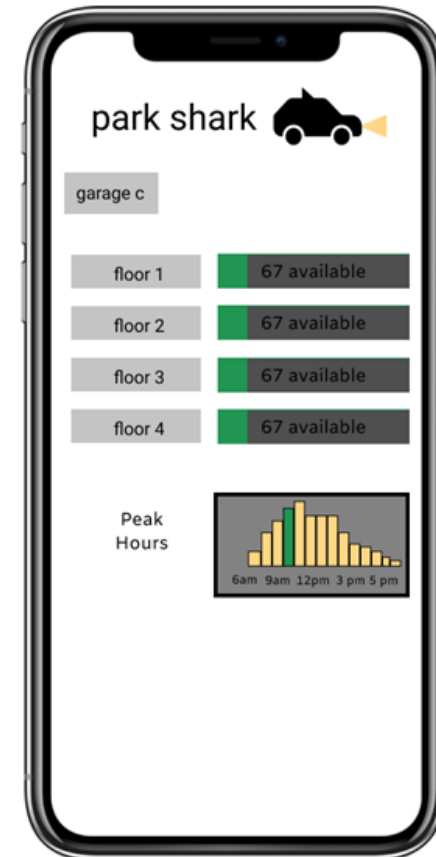

Project Overview

- Detection:
 - Computer Vision: Object Detection
 - Ultrasonic Sensor
- Information Display
 - Website
 - App

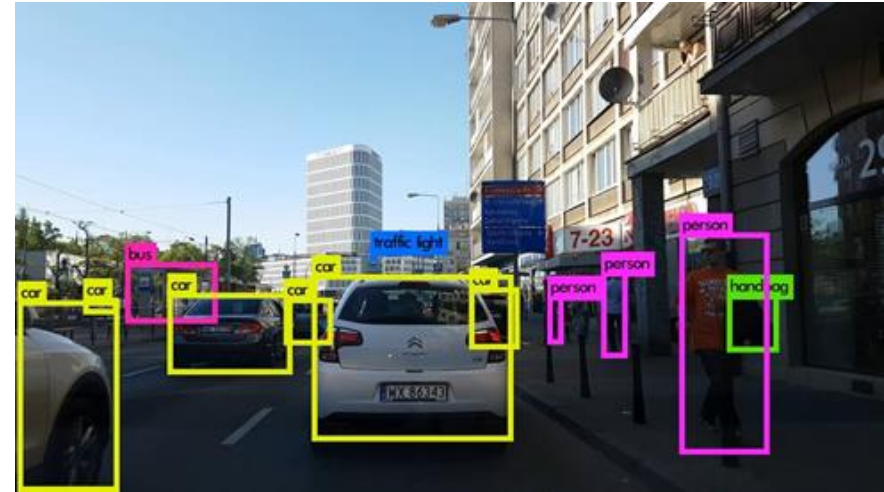

Specifications and Requirements (Computer Vision System)

Design Attribute	Goal
Small form factor	<ul style="list-style-type: none">• Dimensions of product should not exceed 2.9 x 8.9 x 6.5 inches• Weight of product should not exceed 10 lbs
Low cost	<ul style="list-style-type: none">• The production of a single vision system should not exceed \$200• No single component should exceed \$150
Power	<ul style="list-style-type: none">• This module shall pull no more than 300 mA• This device will be run off a small 12 V battery pack, and will require a recharge/change every 24 hours
Communication	<ul style="list-style-type: none">• Be able to receive sensor reading wirelessly via Bluetooth• Transmit data to database over WiFi

Specification and Requirements (Wireless Sensor System)

Design Attribute	Goal
Small form factor	<ul style="list-style-type: none">• Dimensions of product should not exceed 4 x 3.7 x 3.1 inches• Weight of product should not exceed 3 lbs
Low cost	<ul style="list-style-type: none">• The production of a single system should not exceed \$50
Operating distance	<ul style="list-style-type: none">• Unit should be able to detect vehicles at least 5 ft. from the wall or the ceiling
Communication	<ul style="list-style-type: none">• Unit should be able to transmit data wirelessly via Bluetooth
Power	<ul style="list-style-type: none">• This module shall pull no more than 200 mA peak current• This device will run off a small battery pack• The device should enter a power saving mode in between taking sensor readings• Battery life of around 1 year

Overall Block Diagram

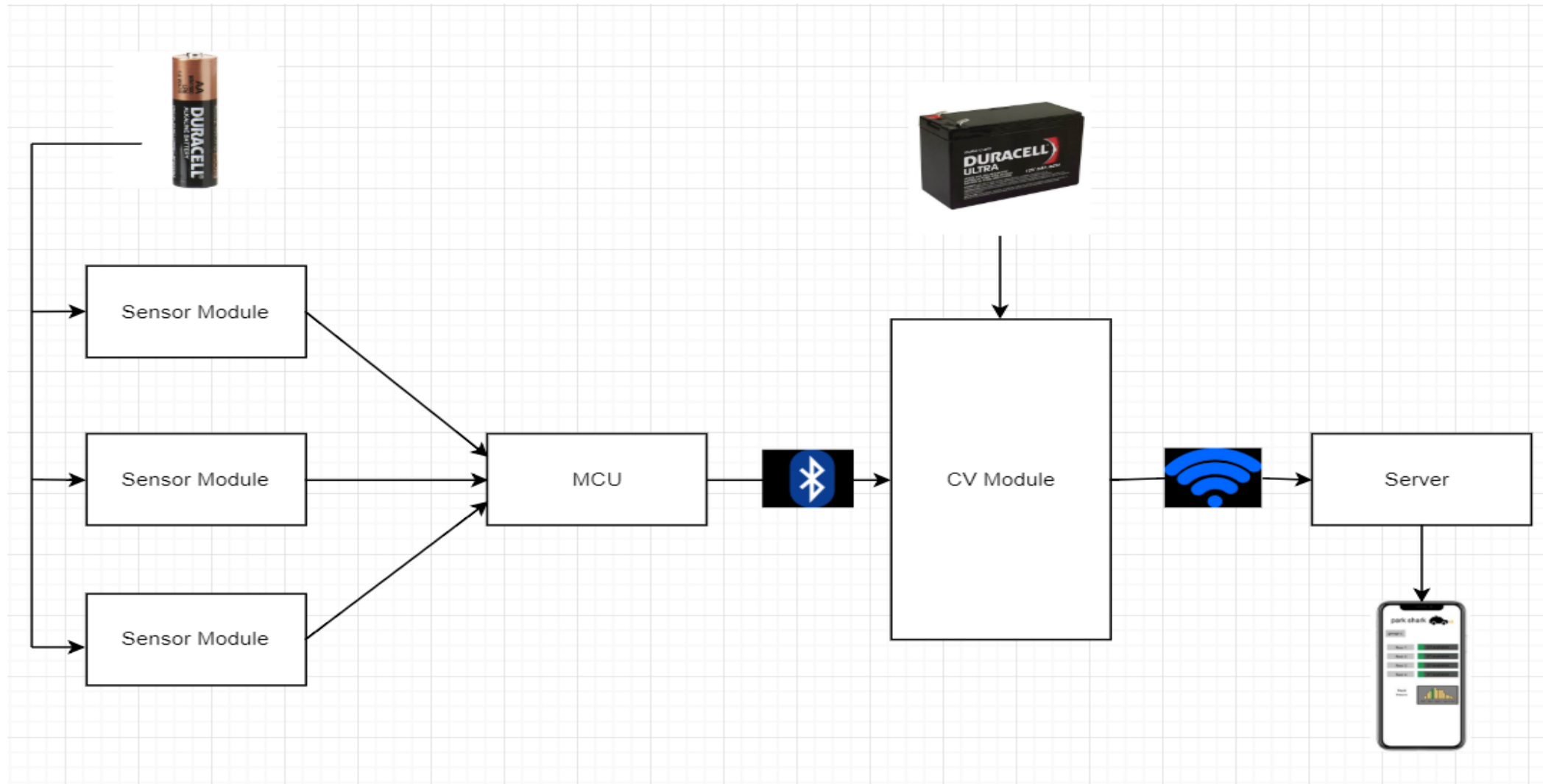

Sensor Block Diagram

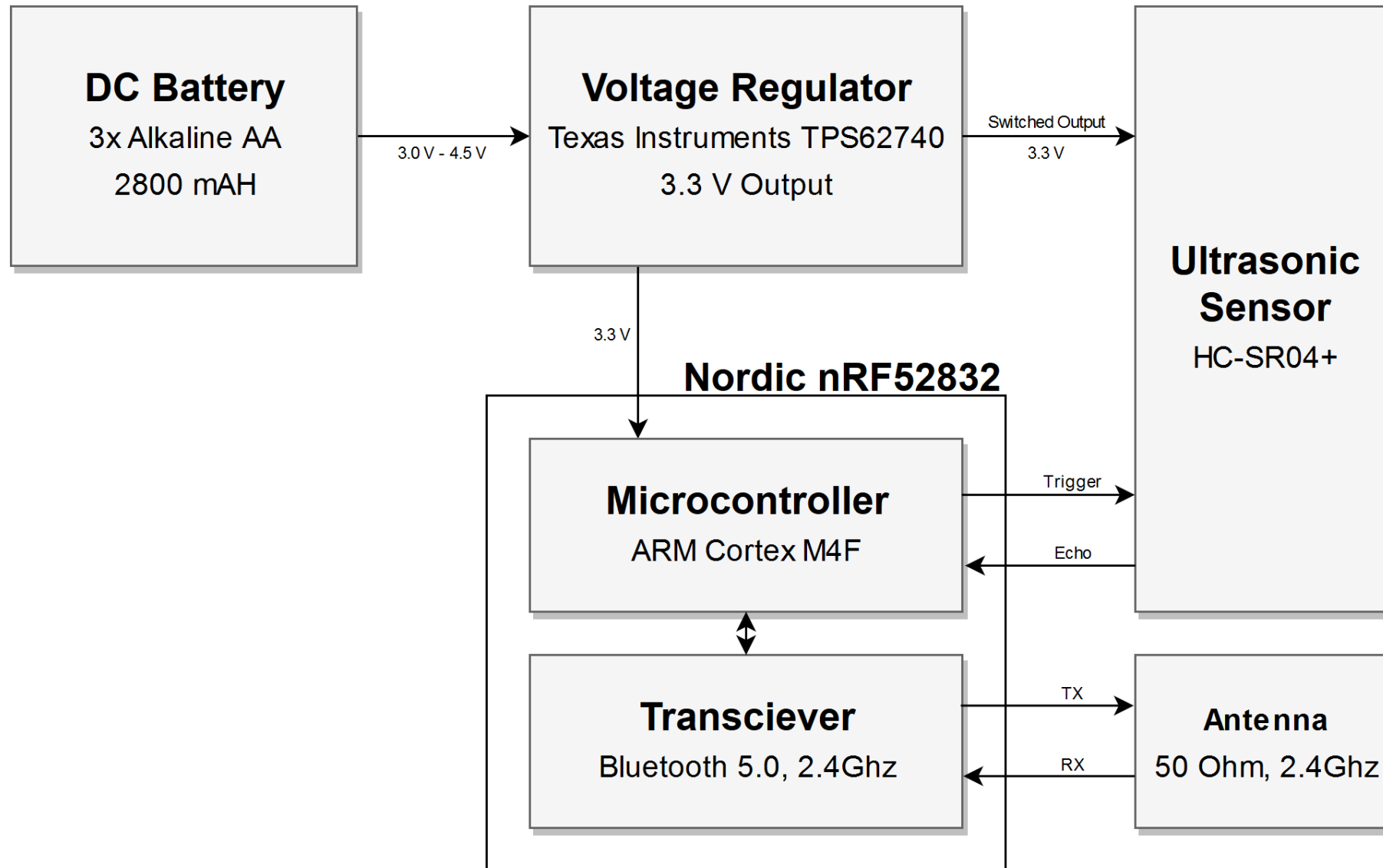

Microcontroller Selection

- Modern Bluetooth with integrated MCU allows lowest power draw and most processing power compared to separate old MCU such as MSP430
- Processing power not important for this application as it will sleep most of the time

Processor	ATmega328	MSP430FR400	<u>nRF52832</u> (ARM Cortex M4)
Low Power Mode Current Draw	4.5 μ A	1 μ A	0.7 μ A
Integrated Bluetooth	No	No	Yes, Bluetooth 5.0
Price	\$1.95	\$1.18	\$3.51

Sensor Comparison

Specifications	Hall Effect	Ultrasonic	Infrared	Inductive
Max Sensing Distance	12 mT*	4 m	1.5 m	0.04 m
Supply Voltage	2.5 to 38V	4.5 to 5.5V	4.5 to 5.5V	10 to 30V
Operating Temperature	-40 to 125°C	-15 to 70°C	-10 to 60°C	-25 to 75°C
Cost	\$0.83	\$3.95	\$14.95	\$62

*Hall effect sensors are triggered by a change in the magnetic field. Instead of a sensing distance, its maximum operating point was written.

Ultrasonic sensor was chosen due to:

- Offers the highest sensing range
- Cost falls within budget
- Low power consumption

$$\text{Distance} = \frac{\text{Time Taken} \times \text{Speed of Sound}}{2}$$

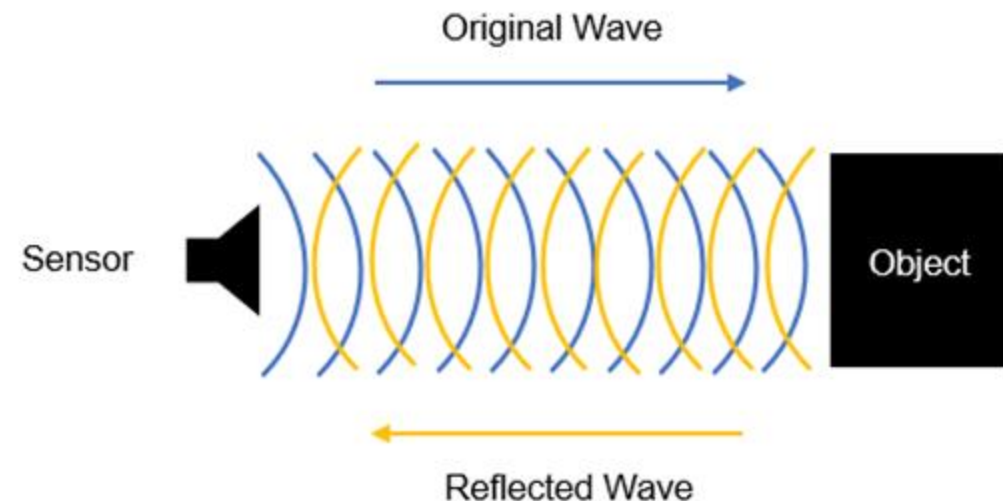

Ultrasonic Sensor

Advantages	Disadvantages
<ul style="list-style-type: none">• Detection of objects by ultrasonic sensors is unaffected by its color, transparency, or light reflectivity	<ul style="list-style-type: none">• Size, shape, and angle of an object can affect the accuracy of the ultrasonic sensor's readings
<ul style="list-style-type: none">• Certain environmental conditions such as dust, humidity, and dirt do not affect ultrasonic sensors	<ul style="list-style-type: none">• Difficult to detect objects of low density, such as fabric or foam
<ul style="list-style-type: none">• Can detect metallic objects without contact	<ul style="list-style-type: none">• Sensitive to variation in temperature

Ultrasonic Sensors

Specification	HC-SR04	HC-SR04+
Operating Voltage	4.5 to 5.5 V	3.0 to 5.5 V
Operating Current	10 to 20 mA	10 to 20 mA
Quiescent Current	4 mA	3 mA
Price	\$3.95	\$1.44



HC-SR04

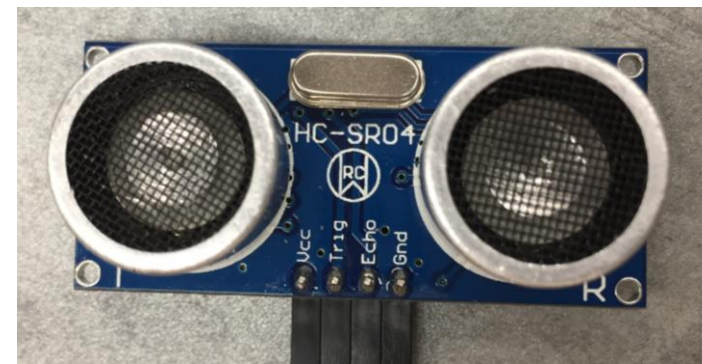

HC-S04+

Wireless Communication

Wi-Fi

- Higher range
- Power requirement too high

Bluetooth

- Data bandwidth not important for this case
- Designed for low power
- Bluetooth 5 extends range and reduces power further
- Bluetooth 5 adds mesh network functionality

Schematic

- 2 main sections:
 - Power Supply
 - MCU
- Sensor is shown on the side
- Made on Eagle CAD

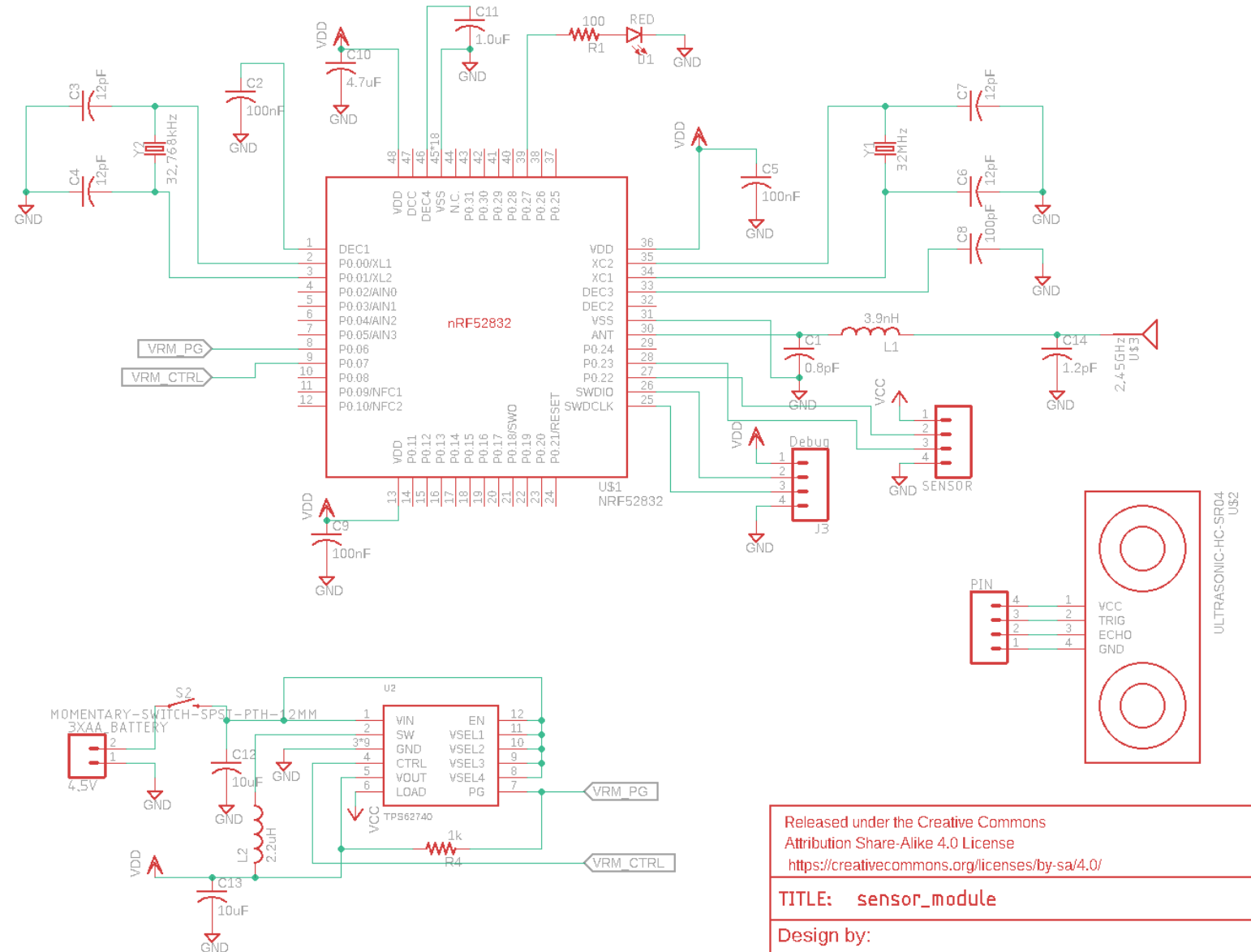

Released under the Creative Commons
Attribution Share-Alike 4.0 License
<https://creativecommons.org/licenses/by-sa/4.0/>

TITLE: sensor_module

Design by:

REV:

Date: 9/11/2018 10:52 AM

Sheet: 1/1

MCU Section

- Decoupling capacitors
 - Reduce noise
- Two crystals:
 - 32MHz
 - 32.768kHz
- Debug port

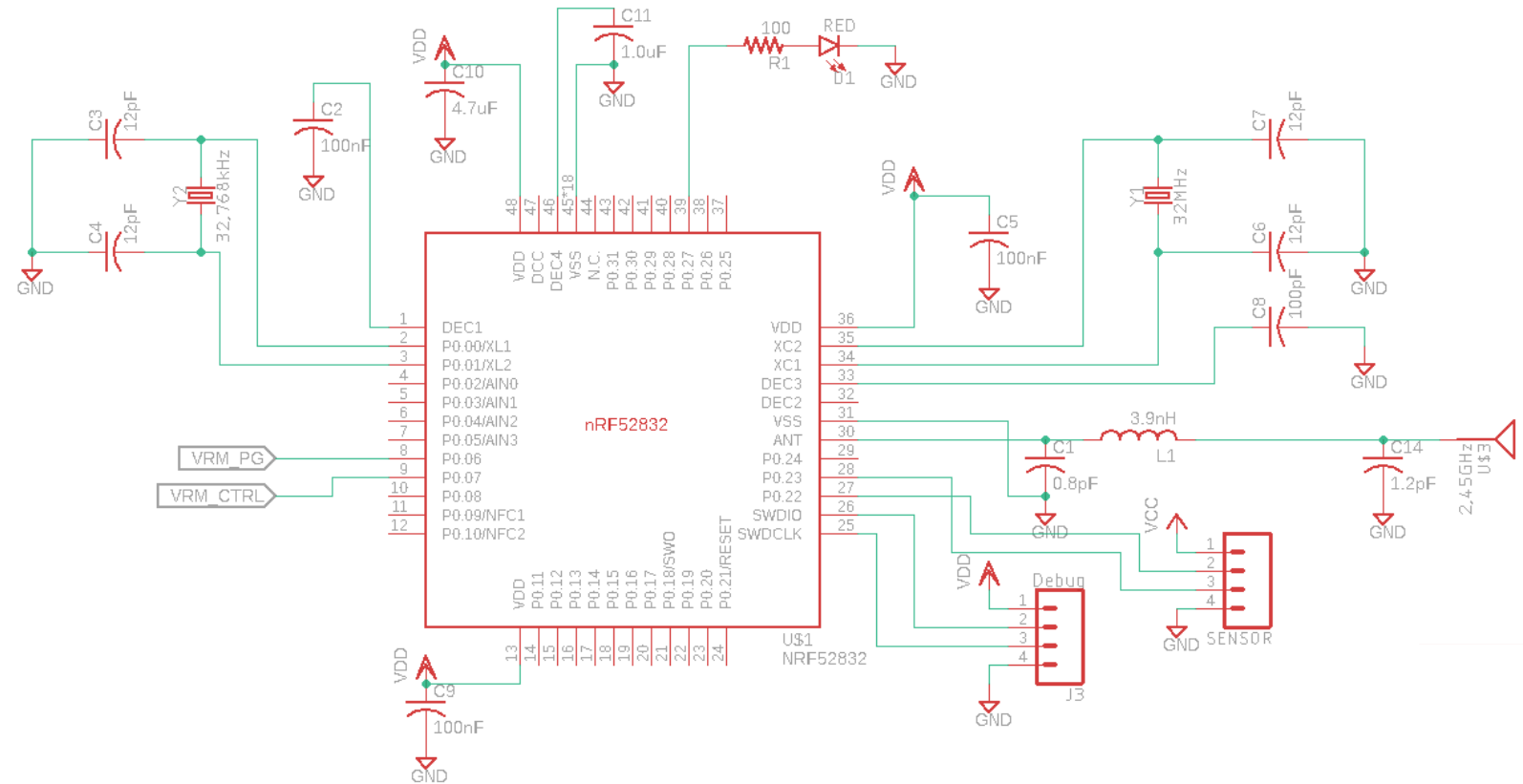

Power Section

- Voltage regulator
- 3xAA battery holder
- SPST switch

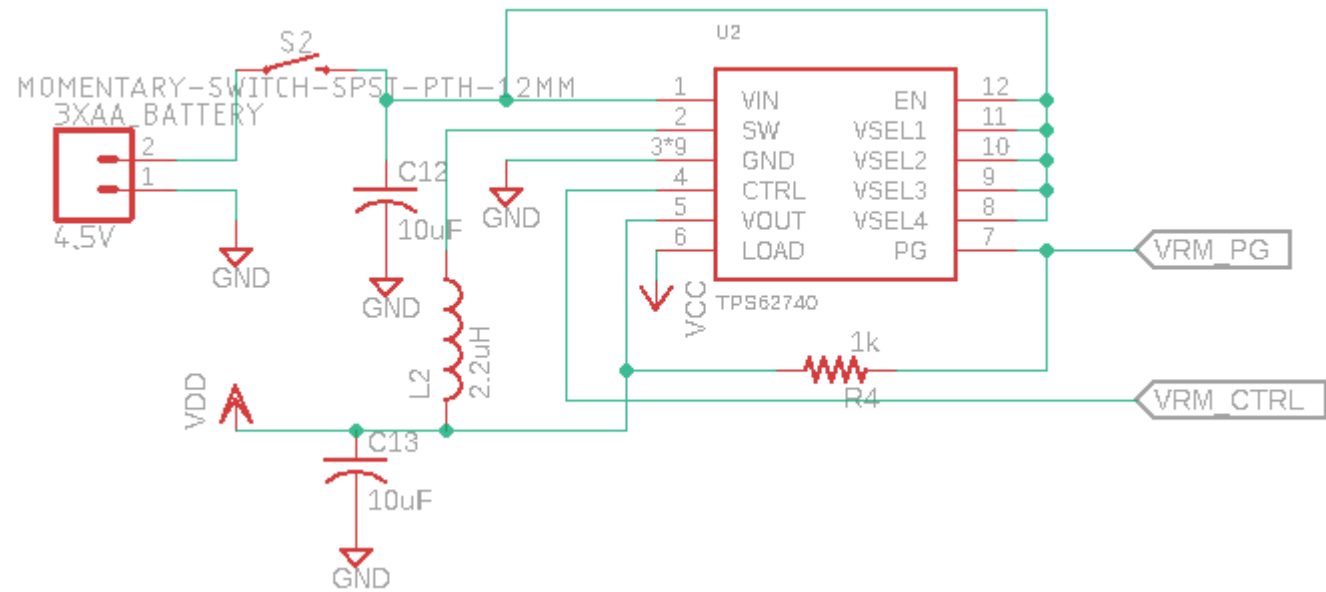

Printed Circuit Board

- Ground plane on both sides
 - Recommended for RF PCB
- Utilized PTH components
- Dimensions: 1.95 in. x 1.95 in.

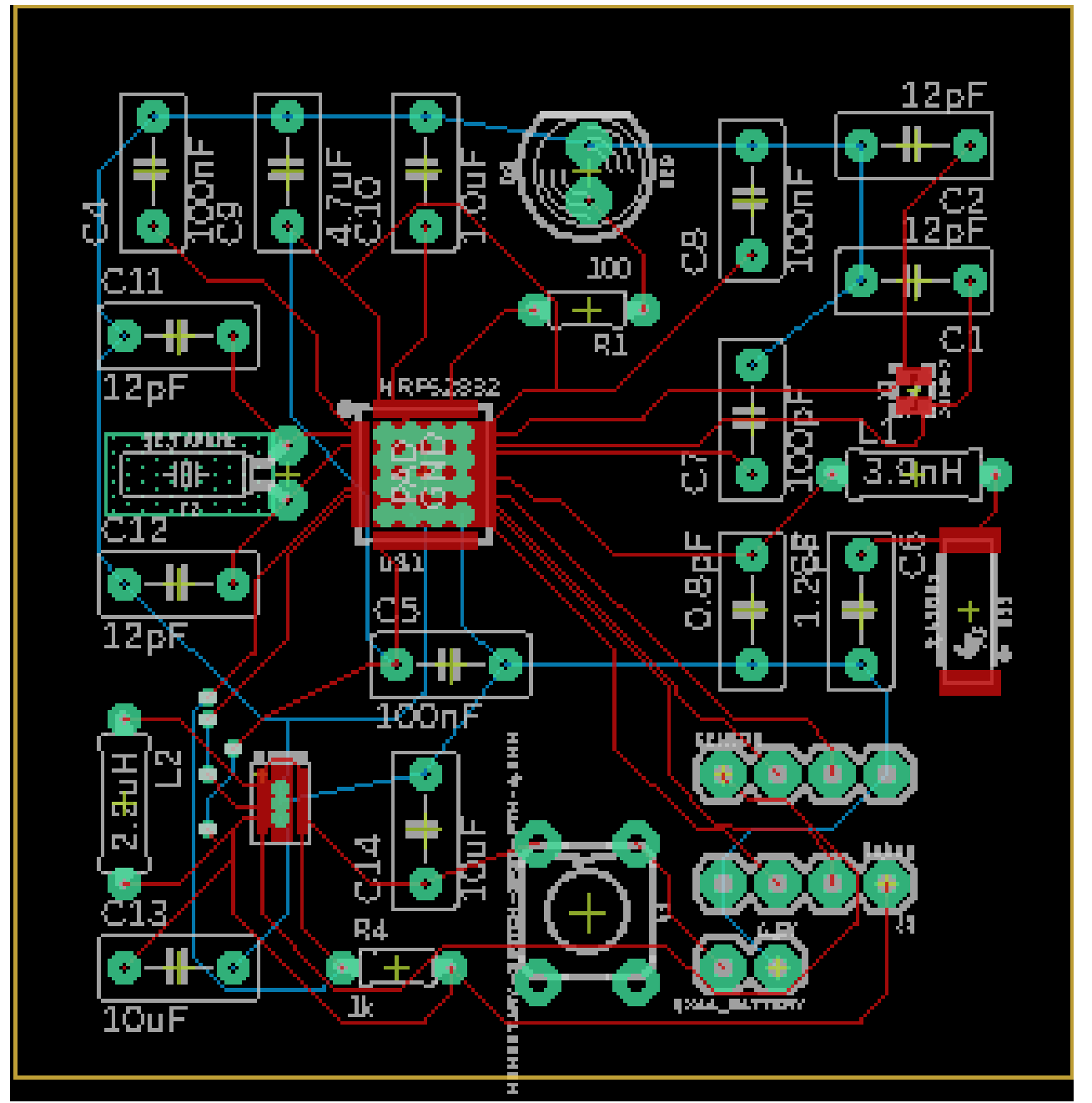
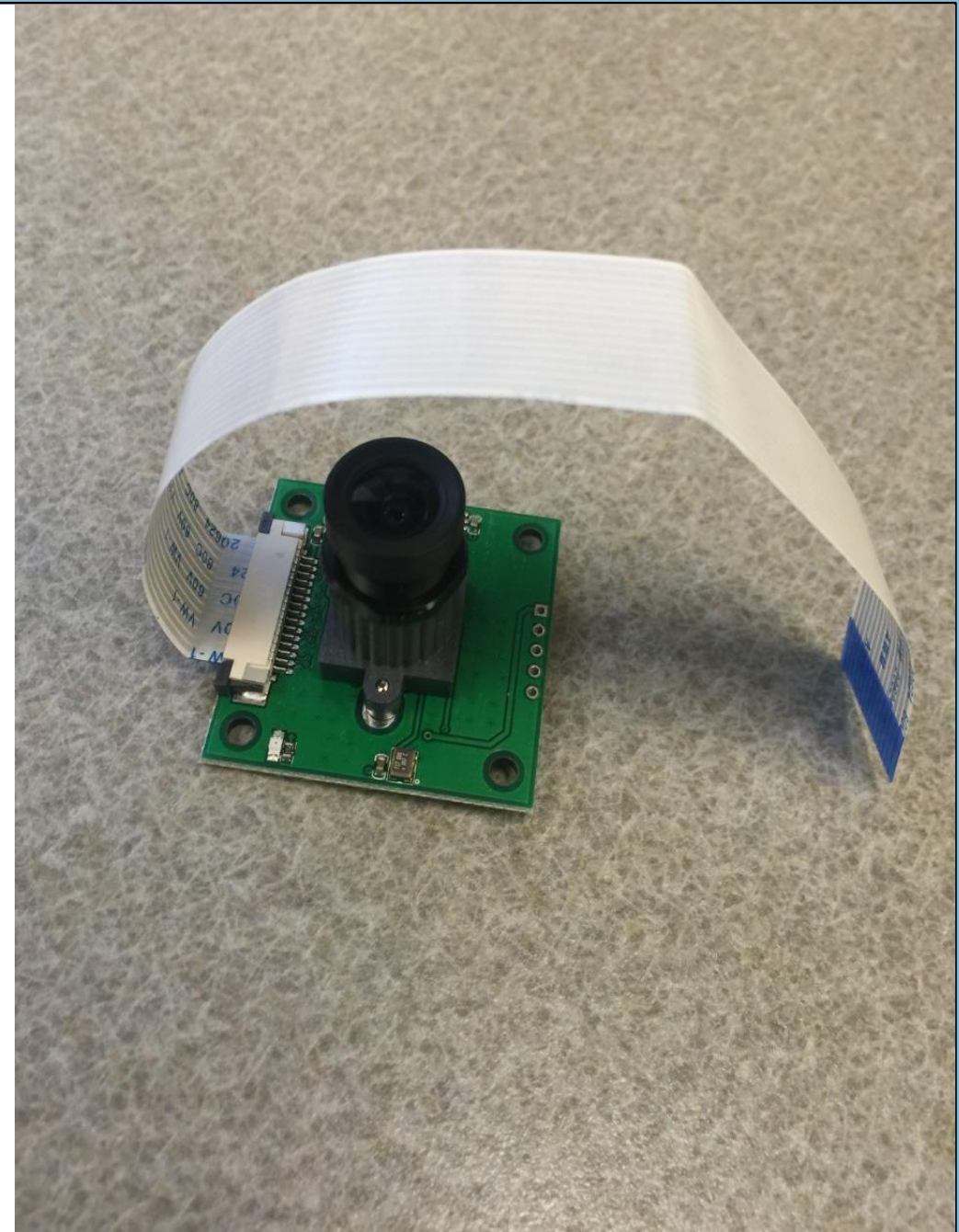

Table of Components

Item	Quantity (Per PCB)	Cost
Nordic NRF52832	1	\$3.51
TPS62740 Voltage Regulator	1	\$1.98
HC-Ro4+ Ultrasonic Sensor	1	\$1.44
2.4GHz Chip Antenna	1	\$2.95
Red LED	1	\$0.40
SPST Switch	1	\$0.50
Pin Head Connector	3	\$0.81
32 MHz Crystal	1	\$1.21
32.768 kHz Crystal	1	\$1.26
Resistor (100, 1k)	2	\$0.12
Capacitor (0.8p, 1.2p, 100n, 2.2u, 4.7u, 10u)	14	\$0.20
Inductor (3.9n, 2.2u)	2	\$0.19
3xAA Battery Holder	1	\$1.50
PCB Board	1	\$15.00
Total Cost	30	\$31.07

Camera Selection

- Pixy Cam
 - Price : \$69.00
 - Outdated
 - Limiting
- Arducam 5 MP OV5647
 - Price : \$13.49
 - Freedom



Computer Vision

- You Only Look Once (YOLO) Algorithm
- Applies a single neural network to the full image and predicts bounding boxes and probabilities for each region
- Supports real-time detection
- YOLO vs Tiny YOLO
- Custom Dataset / Pretrained dataset

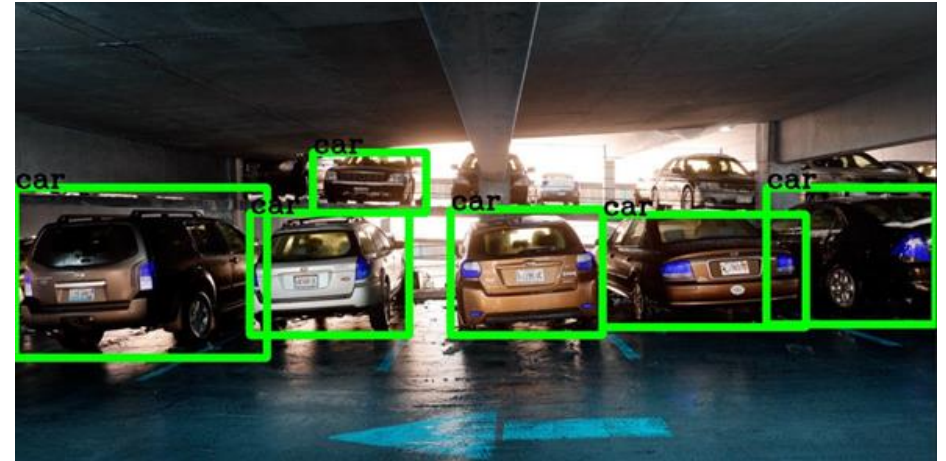

Using the Darkflow open-source implementation of YOLO with Python and Tensorflow

Computer Vision – Issues

- Current implementation will attempt to detect everything
- Our camera should attempt to monitor only a limited number of spots
- How to restrict the detection area ?
 - Manually crop image to look at desired spots after camera installation
 - Attempt to crop image based of results from detection

Mobile Application / Website

- React/React Native
- JavaScript (Since we are using React Native for the mobile application we are going to be using JavaScript)
- MERN
 - MongoDB (Database)
 - Express (Framework to help with node)
 - ReactJs
 - NodeJs

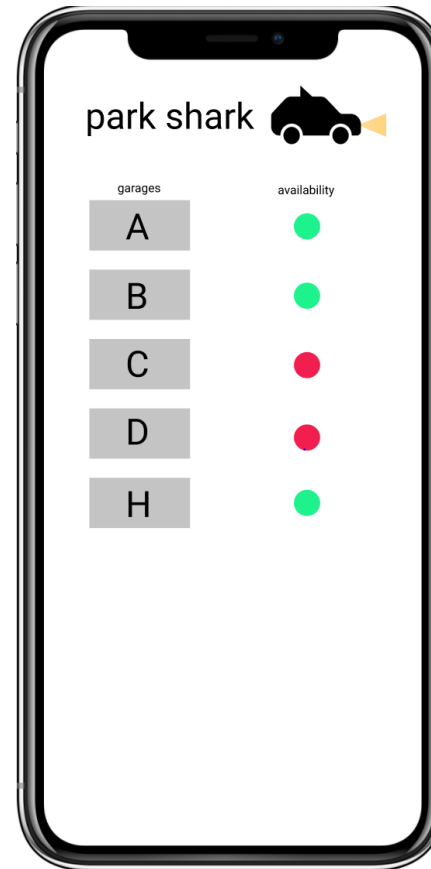

User Interface

Administrator

- This user will be able to register and login (More details in later slides)

Standard User

- This is for all other users. (Anyone just looking for info on the UCF garages)
- Ability to select between all available garages.
- FAQ
- Contact

UI Block Diagram

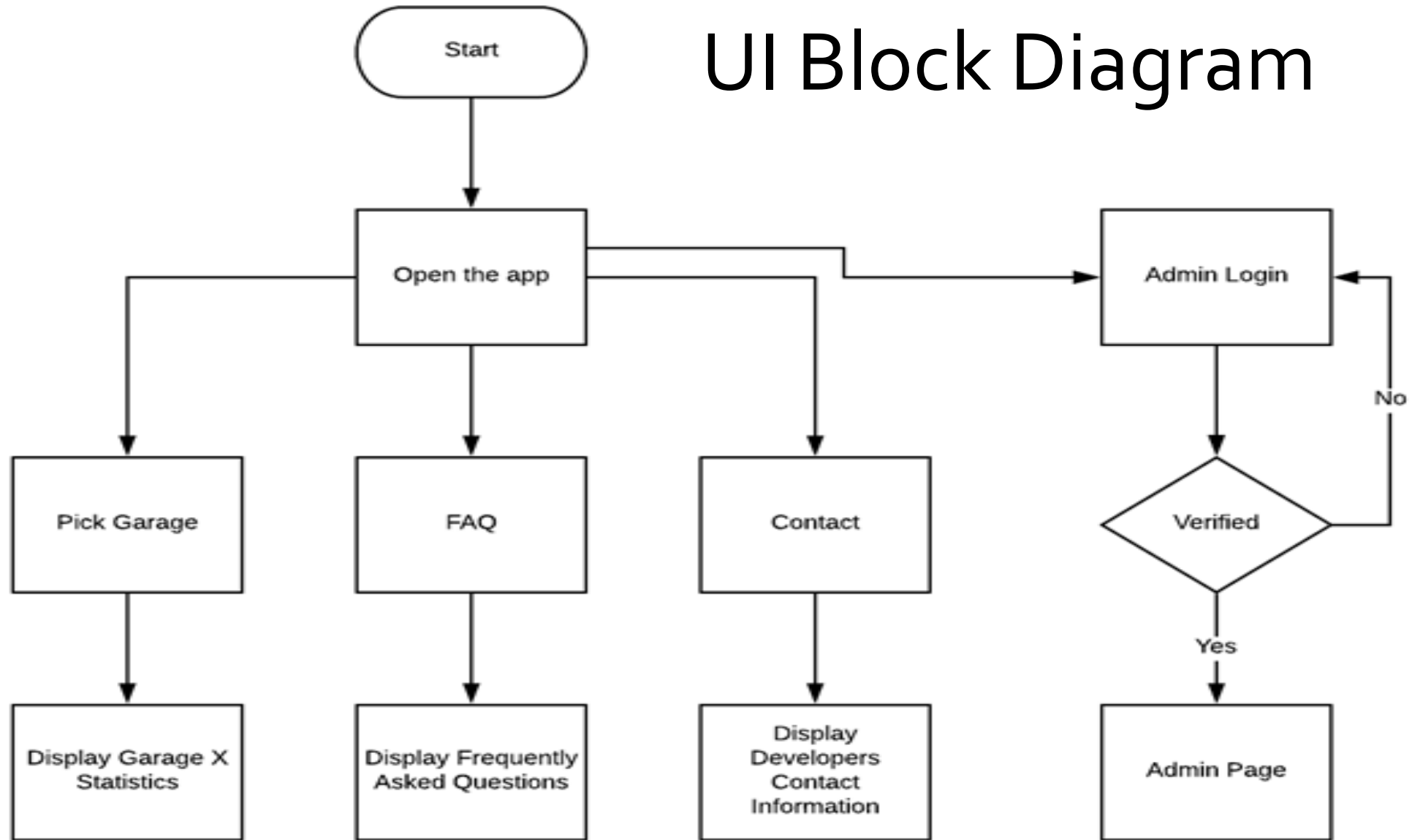

Development Tools

Tool/Software	Description
Git	Git will be used for all software version control
Figma	Figma will be used to design all UI interfaces
Postman	Postman will be used to simulate calls to the database and will assist greatly in the design and testing phase of the website
React	Will be used to create the front-end of the application
Redux	Will be used in tandem with React to handle all transfer of data from the back-end to the front-end
Node.js	Will be used to create the back-end of the application
MongoDB	Will be used to create the database for this application
Mongoose	Will be used in tandem with MongoDB and Node.js to help communicate between the two
React Native	Will be used to implement the mobile application
Android Studio	Android Studio will be used to implement react native tools, as well as using an emulator to simulate a phone and debugging.

Overall Website / App Structure

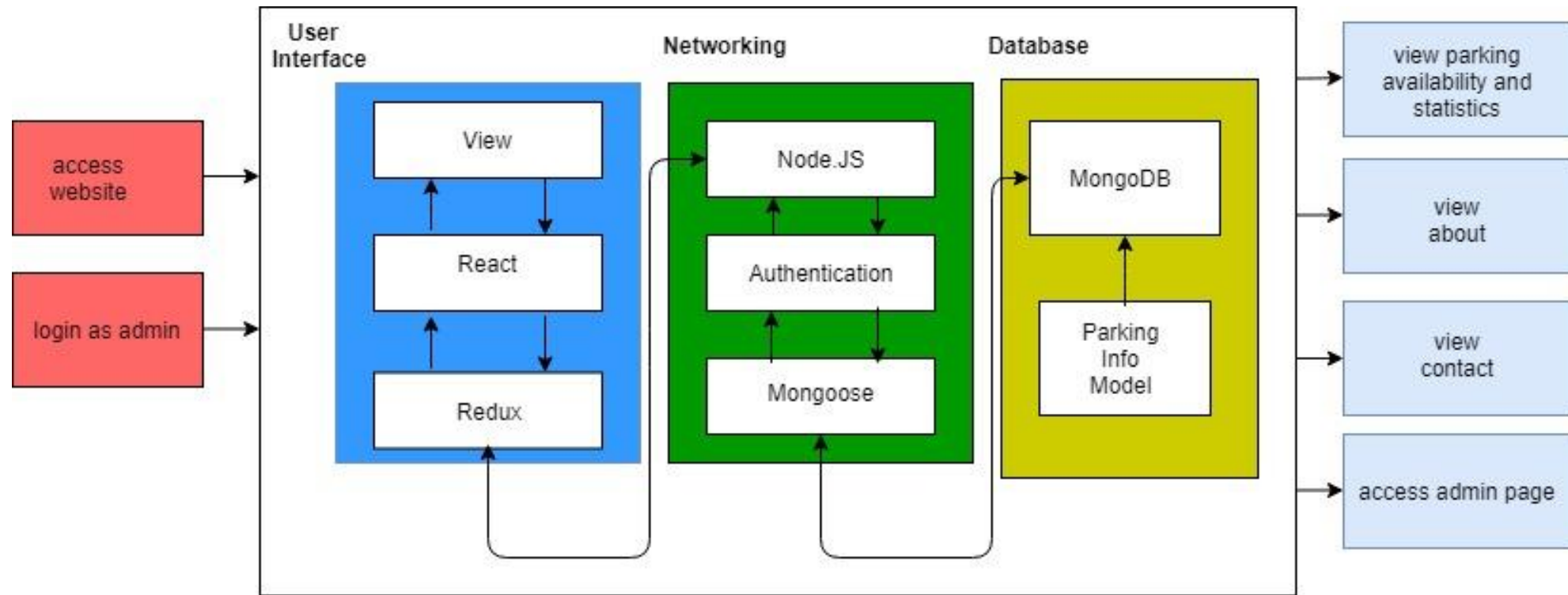

Computer Vision Prototype

- Raspberry Pi 3 Model B+
- Arducam 5 Megapixel
- DROK LM2596 Voltage Converter 12V to 5V
- 12 V Battery Pack

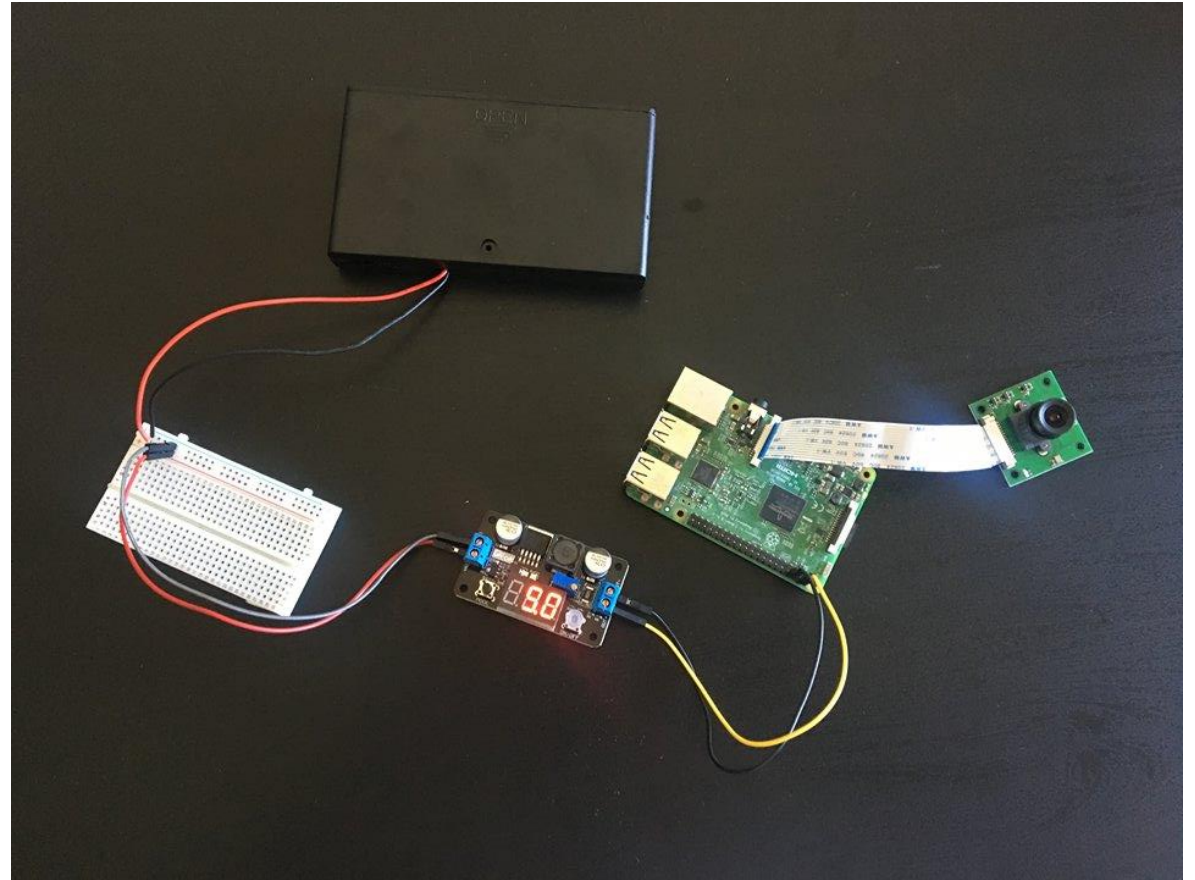

Sensor Prototype

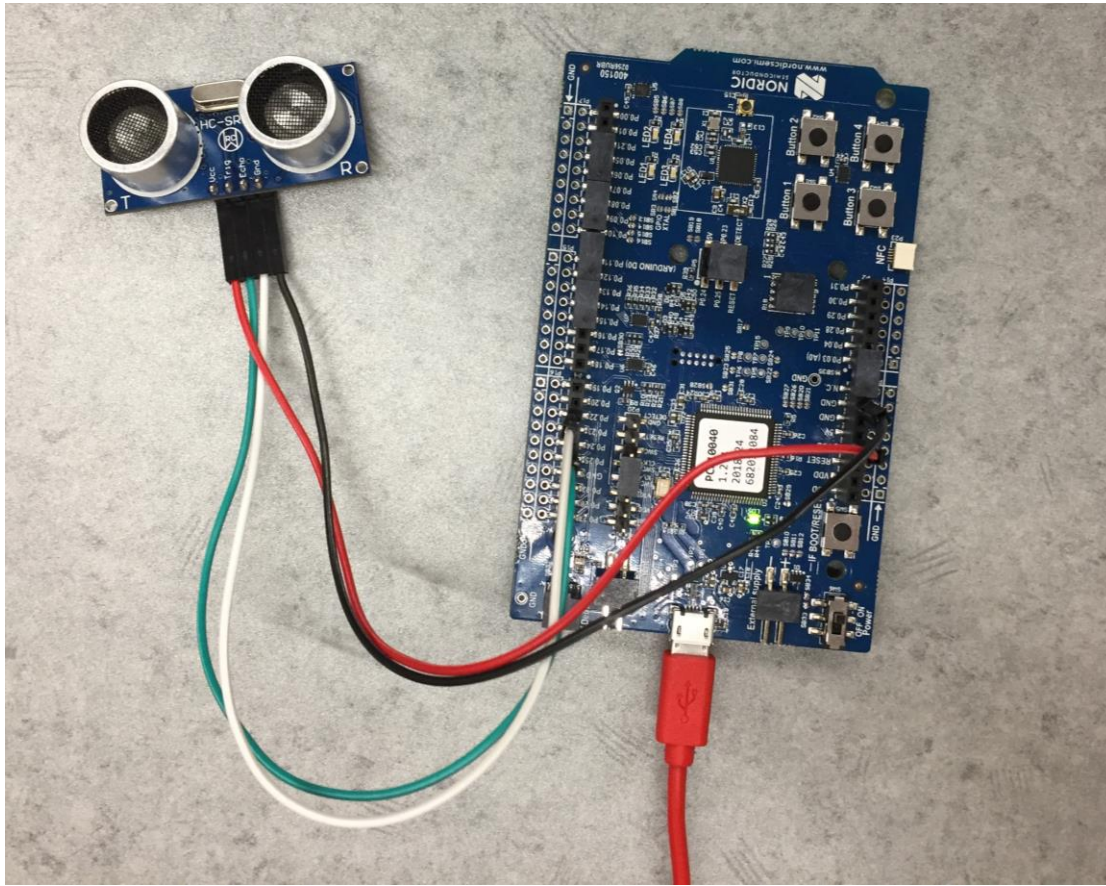

```
Debug Terminal
```

```
Distance: 0.00 meters  
Distance: 0.07 meters  
Distance: 0.10 meters  
Distance: 0.15 meters  
Distance: 0.19 meters  
Distance: 0.24 meters  
Distance: 0.28 meters  
Distance: 0.23 meters  
Distance: 0.19 meters  
Distance: 0.37 meters  
Distance: 0.21 meters  
Distance: 0.21 meters
```

Power Conservation

UCF garage occupancy over one day

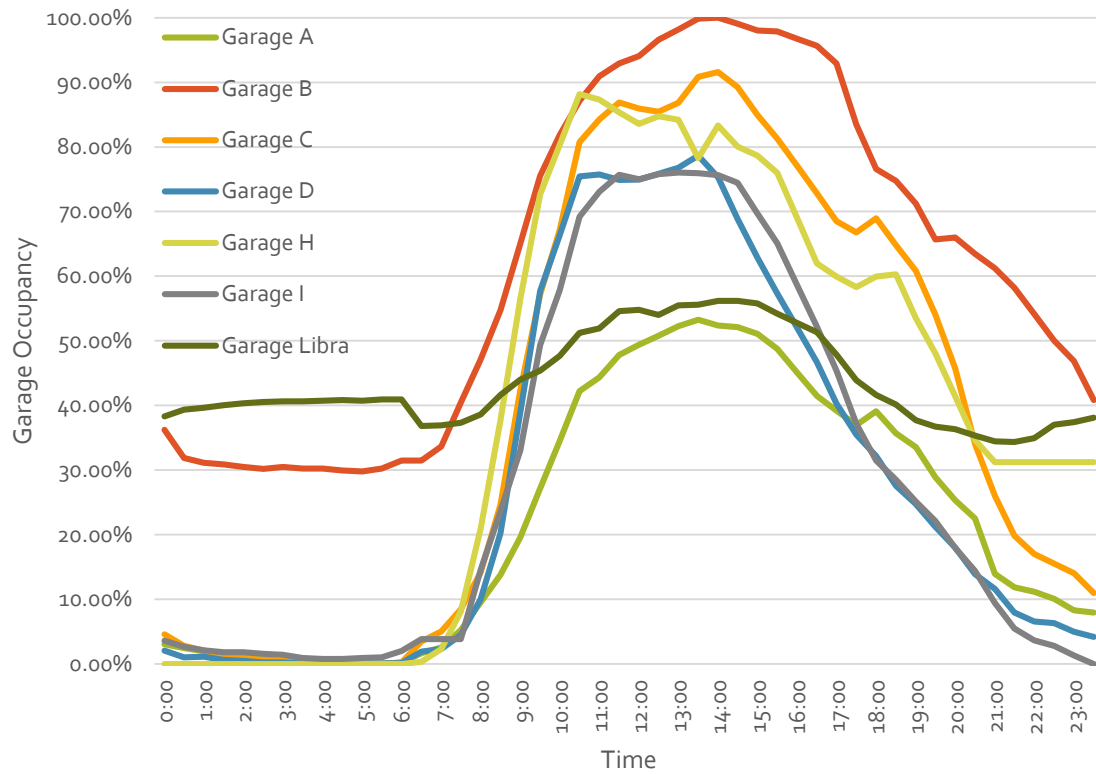

Adjusted occupancy model over one day

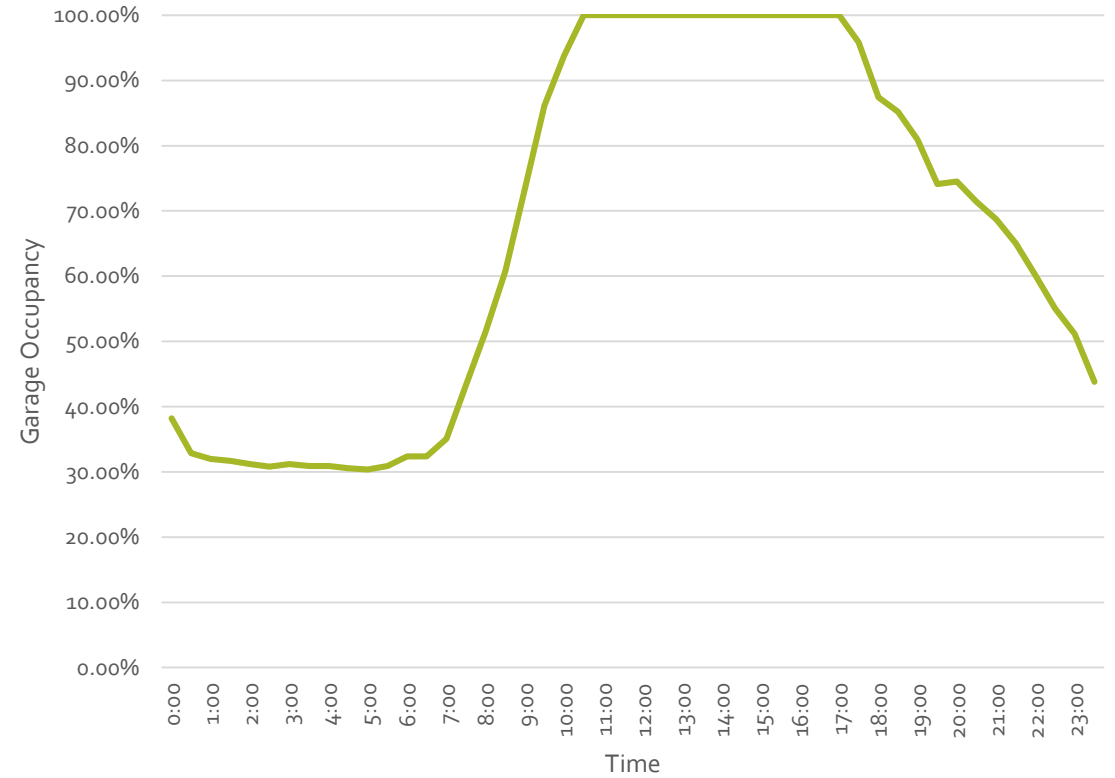

Power Conservation

- Can adjust sensor polling rate depending on garage occupancy to save power
- Frequent updates not needed during nighttime
- Frequent updates desired at high occupancy

Interval Level	Occupancy >	Occupancy <=	Interval Length	Checks Per Hour
1	95%	100%	30 seconds	120
2	85%	95%	1 minute	60
3	70%	85%	5 minutes	12
4	0%	70%	10 minutes	6

Power Draw

Stage	Description	Time (ms)	Length (us)	Avg. current (mA)	Peak current (mA)
pre	Pre-processing	0.0	61	3.4	
ramp	Standby + HFXO ramp	0.1	430	1.5	
stdby	Standby	0.5	1014	0.4	
start	Radio startup + CPU	1.5	133	2.8	
RX	Radio RX	1.6	261	5.7	6.2
switch	Radio switch	1.9	102	5.7	
TX	Radio TX	2.0	323	7.6	8.2
post	Post-processing	2.3	205	3.1	
	System On IDLE	2.5	3997.5 ms	2.0 uA	
Total			4000.0 ms	3.7 uA	

- Ultrasonic current draw is 4 mA
- Bluetooth/MCU current draw is negligible compared to Ultrasonic Sensor
- Therefore, keep MCU running and only schedule Ultrasonic pulses to minimize power draw
 - Need voltage regulator that can switch off one output while keeping MCU powered

Voltage Regulator

Texas Instruments TPS62740

Feature	Specification
Efficiency	90% at 10 μ A output
Max Current Output	300 mA
Voltage Input Range	2.2 V – 5.5 V
Voltage Output Range	1.8 V – 3.3 V
Number of Outputs	2 (1 toggleable)
Cost	\$1.76 at Mouser

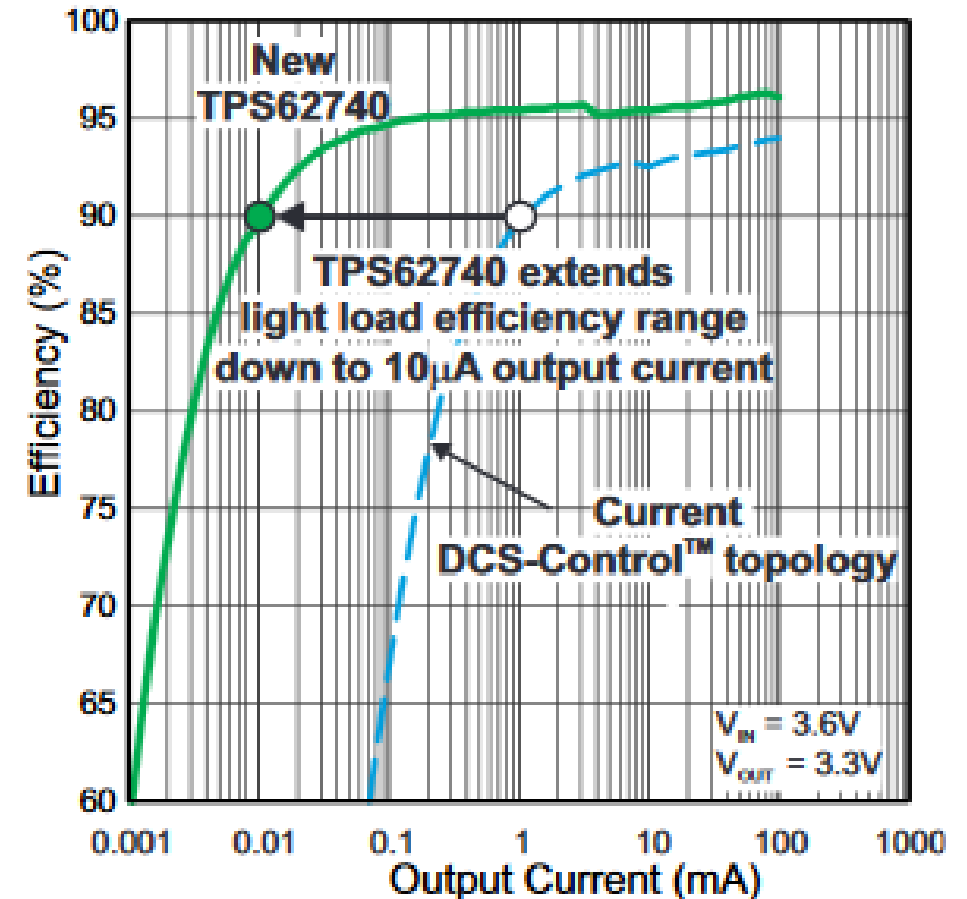

Battery Selection

- Estimated current drawn by sensor module after activation scheduling is $50\mu\text{A}$
- Desired battery life is a year or 8760 hours
- Necessary battery capacity is **438 mAh**
- Chose AA batteries due to:
 - Small size
 - Easy attainability
 - Low cost
- 3 AA batteries will be used
 - Nominal voltage of an alkaline cell is 1.5 V
 - $3 \times 1.5 = 4.5\text{ V}$

Battery Size	Battery Capacity (mAh)
9V	570
AAA	1150
AA	2870
C	7800
D	17000

$$\frac{\text{Battery Capacity (mAh)}}{\text{Current Draw (mA)}} = \text{Battery Life (hours)}$$

System Housing Requirements

Parameters:

- Sensor measuring angle: 15 degrees
- Sensor dimension: 1.78" x 0.79" x 0.6"
- PCB dimension: 1.95" x 1.95"
- Battery holder dimension: 2- $\frac{1}{4}$ " x 1- $\frac{15}{16}$ " x $\frac{5}{8}$ "
- Placement of components

System Housing for Sensor Module

- 3D Printed in TI Innovation Lab
 - ABS plastic
- Modeled in Fusion 360
- Dimensions:
 - Box: 3.1 x 3.1 x 2.5 in.
 - Lid: 3.1 x 3.1 x 0.2 in.

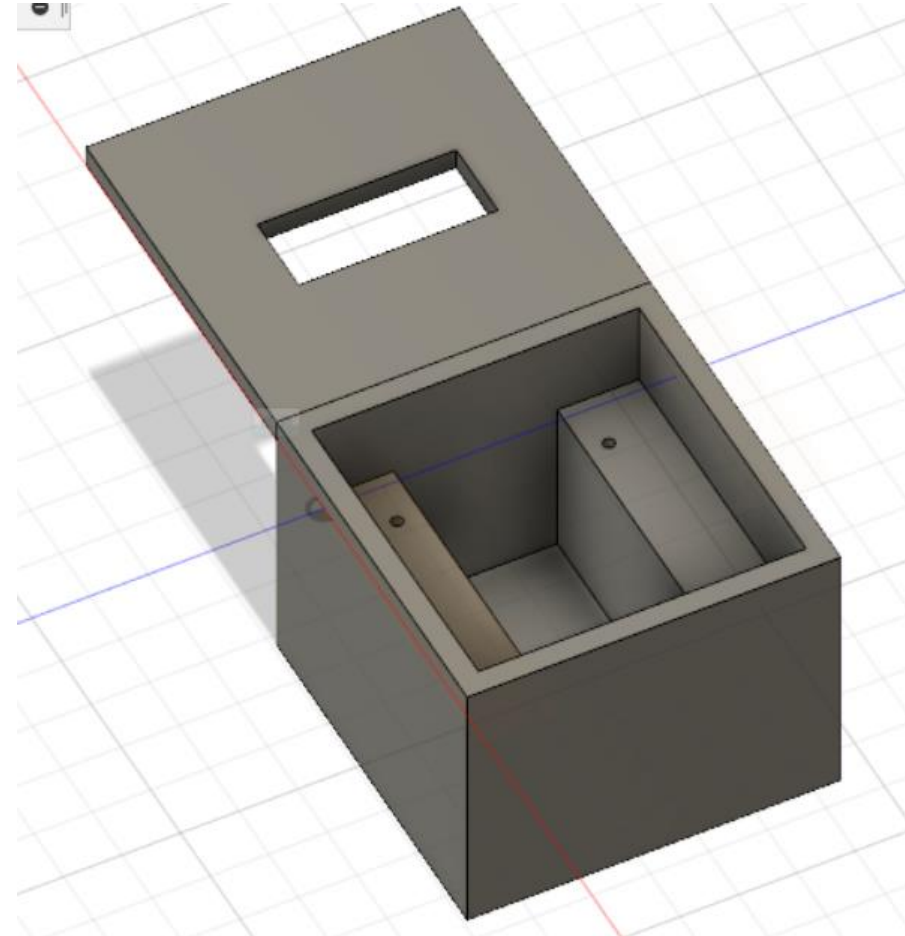

System Housing for CV Unit

- 3D Printed in TI Innovation Lab
 - ABS plastic
- Modeled in Tinker CAD
- Dimensions:
 - Box: 2.3 x 4.3 in.
 - Lid: 2.1 x 4.1 in.

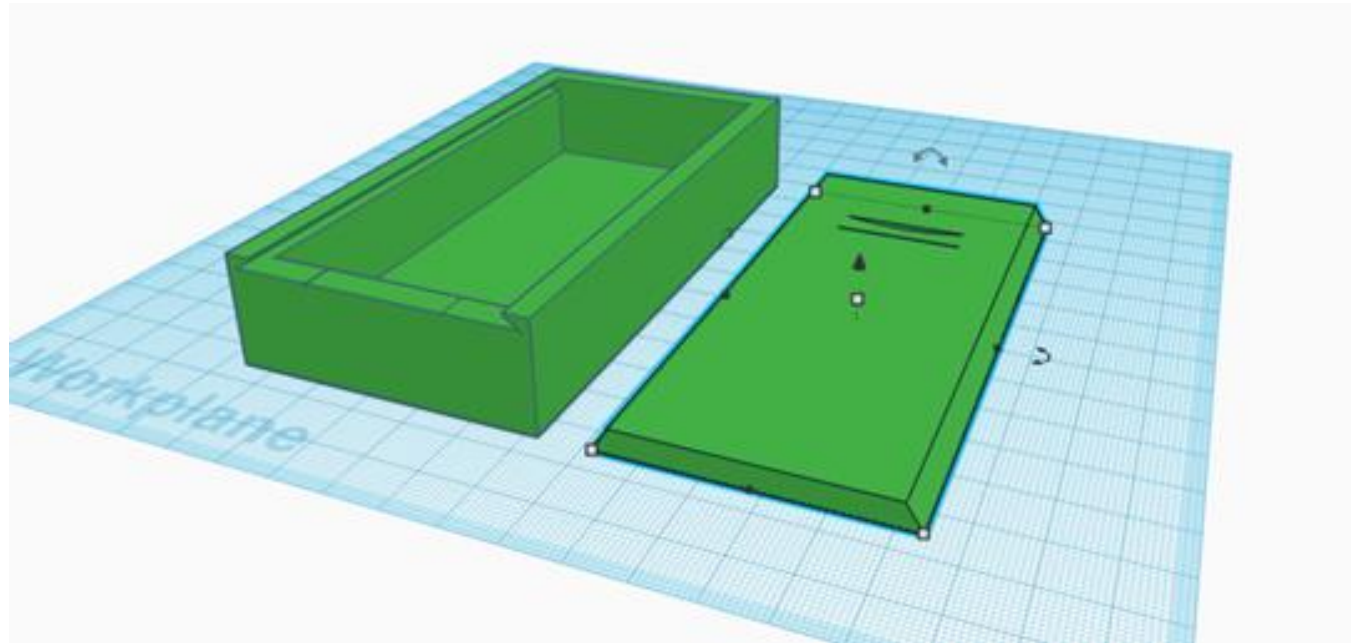

Work Distribution

Team Member	Sensor Hardware	Sensor Software	Computer Vision	PCB	Mobile App	Website	Power Supply
Keegan			P		S	P	
Marcelino			S		P	S	
Beatriz	P	S		P			S
Travis	S	P		S			P

Legend

P: Primary

S: Secondary

Budget

Item	Unit Cost
Arducam 5 MP OV5647	\$14.99
Raspberry Pi 3 Model B+	\$35.00
16 GB Micro USB	\$8.45
9 x AA Alkaline Battery	\$8.91
PCB	\$31.00
Module Housing	FREE
Total Cost	\$98.35

Project Progress

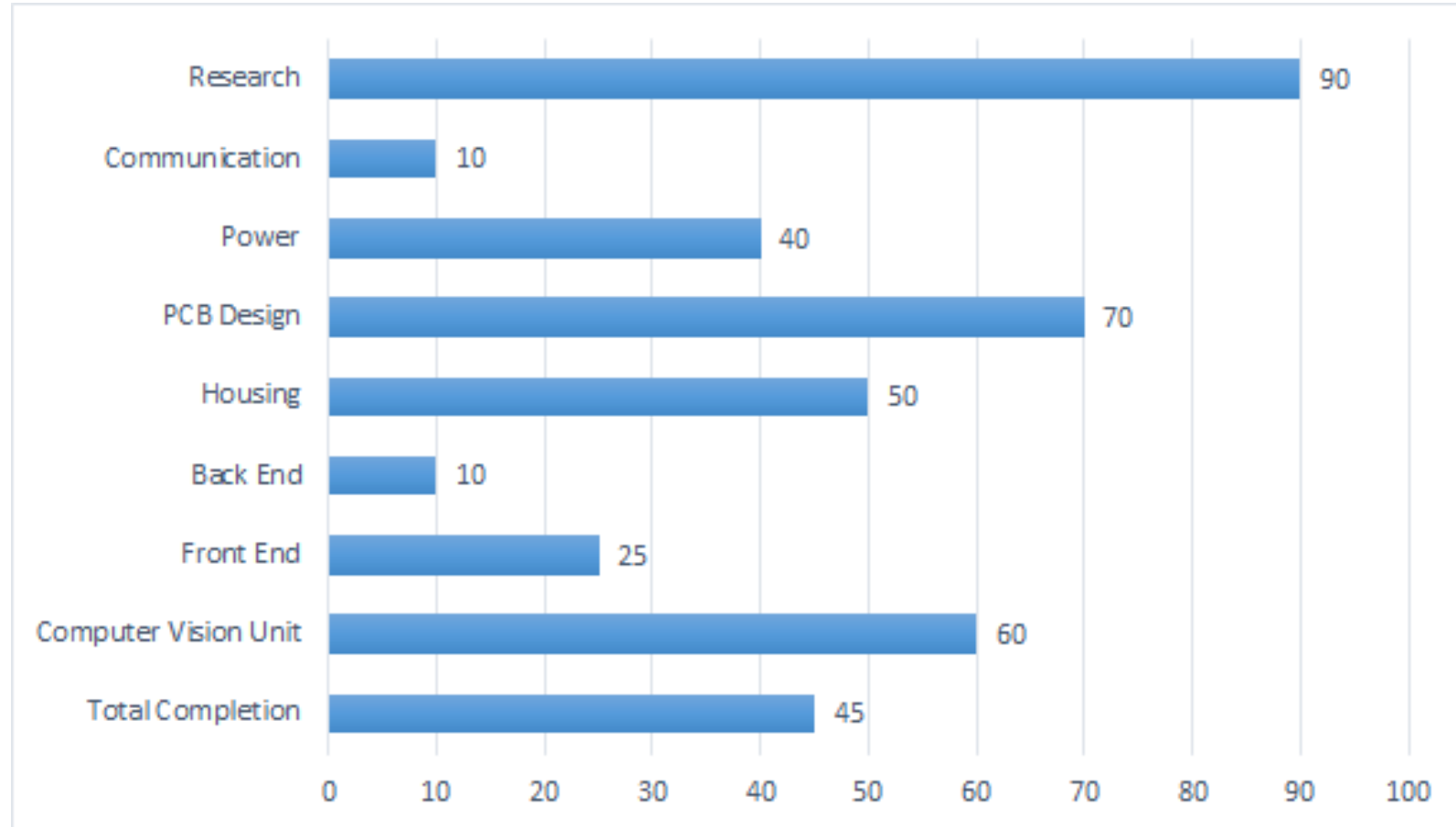

QUESTIONS?
