



Portable Watering Device Group 9

Chris Havekost | CpE
Joan Henriquez | CpE
Peter Nachtigal | EE
Ronak Patel | CpE



Project Motivation

- Growing plants as a hobby
- Learning from a bad personal experience
- Finding the right solution

Purpose

- For those who like to grow plants
- Benefits of owning a home vs. apartment
- Suitable for apartment residents who like growing their plants in balconies
- This system will let the user water their plants remotely, set a timer to water their plants consistently, or use an algorithm to water their plants efficiently

Main Requirements

The system should be

- Efficient : High performance, low power consumption
- Portable : Small in size and lightweight, since apartment renters tend to move more often
- Smart : Show sensor data and let the user operate the system from a smartphone app

Power Source

- It is important to find a power source that doesn't require any wall outlet to operate
- A power bank or battery pack is a good option

Battery

- Powers the MCU, thus the whole system
- This battery is small size and lightweight
- Specifications: 12,000 mAh capacity, 2 USB ports, 5V output



Battery Comparison

Battery Model	Protection	Battery Capacity (mAh)	Battery Output (V)	Battery Size (in.)	Cost
V15	<ul style="list-style-type: none"> - Short circuit - Over charge - Over discharge - Over current - Over temperature 	4,000	5	4 x 2.5 x 0.5	\$89 (with panel)
V44		12,000	5	4 x 4.25 x 0.75	\$159 (with panel)
V72		19,800	5	7.3 x 5 x 0.6	\$259 (with panel)
Venture 30	<ul style="list-style-type: none"> - Waterproof - 1 year warranty 	7,800	5	4.5 x 3.25 x 1	\$169.99 (with panel)
Rz60G-A	- 1 year limited warranty	6,000	5	4.5 x 2.63 x 0.5	\$39.99

Solar Panel

Comparison of 3 solar cell technologies

- **Monocrystalline Cells - Small in size, highest efficiency, portable**
- Polycrystalline Cells - Large in size (heavy), less efficient, not portable
- Thin-Film Cells - Large in size, less efficient, not portable

Specifications

- 19% efficiency, 6V output, peak current of 1.5A, and peak power of 9W
- Provides a DC input to charge the battery, LED indicators to show charge

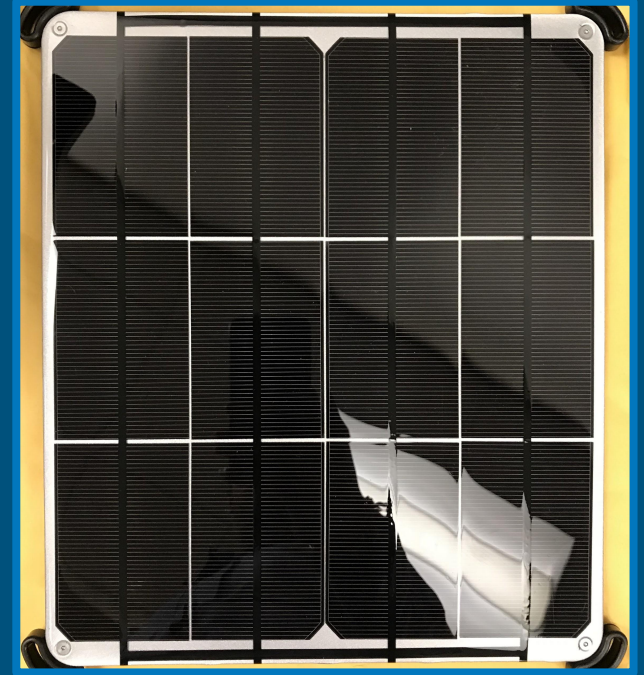

Solar Panel Comparison

Panel Model	Panel Power (W)	Panel Peak Volt. (V)	Panel Size (in.)	Weight (lbs)	Cost
V15	6	6.0	8.7 x 6.9 x 0.2	0.77	\$89
V44	9	6.0	8.7 x 10.1 x 0.2	1.35	\$159
V72	17	17.5	15.5 x 10.75 x 0.25	2.90	\$259
RNG-20D	20	12	13.5 x 18.5 x 1	4.8	\$59.99
RNG-30D	30	12	23.8 x 13.5 x 1	6.2	\$65.99
RNG-100D	100	12	47 x 21.3 x 1.4	16.5	\$149.99
SOL-030)-01	30	12	27.3 x 17 x 2	6.6	\$49.99
Venture 30	7	8-9	9 x 6.5 x 1.5	1.56	\$169.99
Boulder 30	30	12	18.11 x 20.87 x 0.98	7.93	\$137.13
SP-100W	100	17.5	45.5 x 1.5 x 26.5	20	\$129.99

Battery and Solar Panel Testing

- Battery was tested by simply trying to charge a phone with it
- LED indicators were tested by checking if they turned off as the battery was losing charge
- Solar panel was tested by connecting the battery and checking whether it charges the battery when under the sun

Hardware Diagram

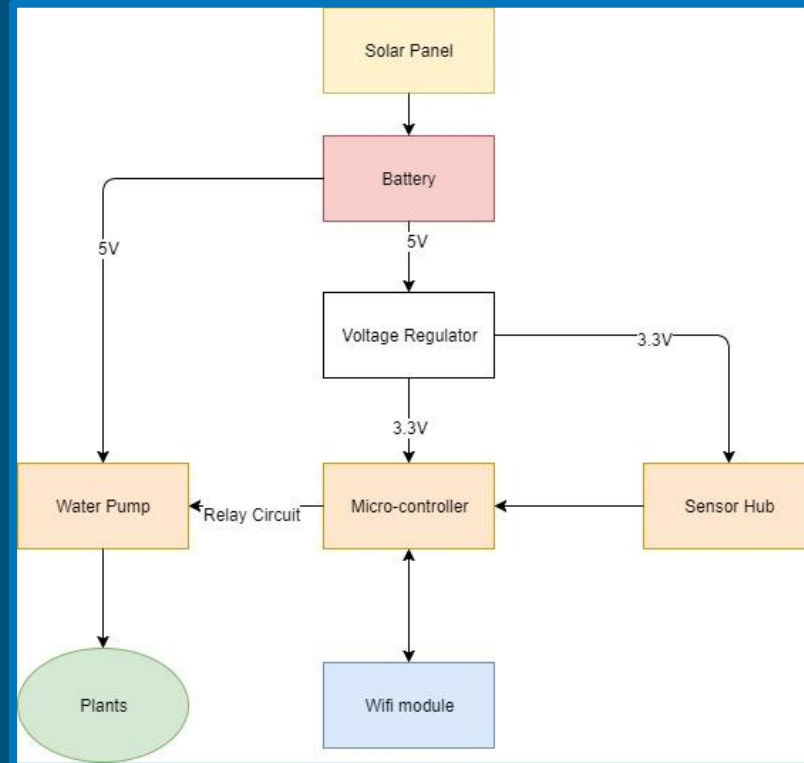

Sensors

- Need to be able to measure relative humidity (RH), temperature, and the pressure of air surrounding the plant
 - Nice for users to see these values when looking at the application
 - We will be using this data to determine suitable times to automatically water plants
- Also need to monitor the water level in the tank
- While researching, we valued size, power consumption, and accuracy
 - Didn't want components to fail prematurely when operating outside for extended periods
- Had to decide between analog and digital sensors

Bosch BME280

- Combines temperature, pressure, and humidity sensing into one discrete package
 - Saves physical space on PCB, only 2.5 x 2.5 x 0.93 mm
- \$7.58 per unit
 - Performance-to-price ratio was hard to ignore
 - Purchased from Digi-Key
- Operates between 1.7V to 3.6V, drawing 1.8 μ A to 3.6 μ A
- Operates from -40°C to 85°C, 0% to 100% relative humidity, and handles between 300 to 1100 hPa of pressure

Soldering Sections, BME280 (in mm)

- We realized it was too small once it was delivered
- Precision required for soldering was too much for us
- Would have no way to test

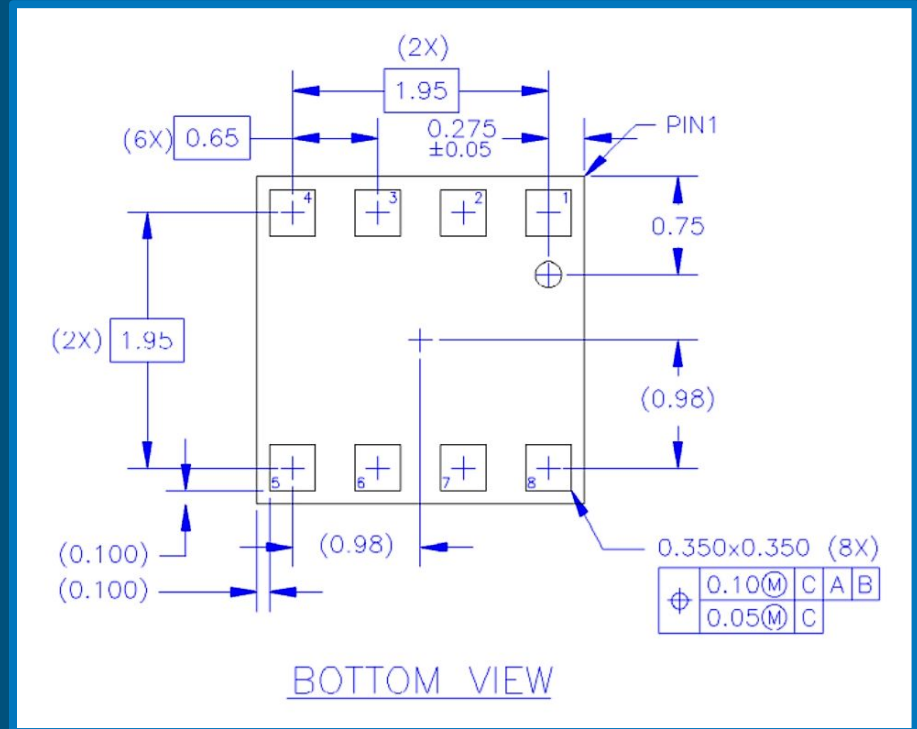

Humidity Sensor

Sensor	RH Range	Temperature Range	Accuracy	Current Consumption	Cost
DHT22	0% to 100%	-40°C to 85°C	±2% RH	1.25mA	\$9.95
HTU21D	0% to 100%	-40°C to 125°C	±2% RH	0.45mA	\$1.33

- HTU21D has the DHT22 beat, but it requires a minimum order quantity
- DHT22 combines temperature and RH sensing

Temperature Sensor

- DHT22 comes with built-in temperature sensor
- Sensor provides 9- to 12-bit measurements
- We'll do an analog to digital conversion to grab the voltage across the sensor, giving the digital sensor a usable value

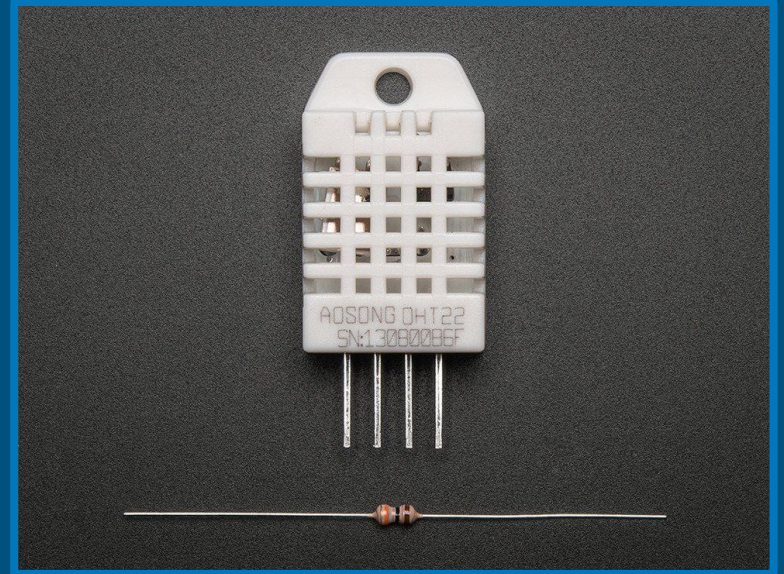

Temperature Sensor Comparison

Sensor	Resolution	Temperature Range	Accuracy	Current Consumption	Cost
DFRobot DS18B20	0.5°C to 0.0625°C	-55°C to 125°C	±0.5°C within -10°C to 80°C	1mA	\$6.90
DHT22 DS18B20	0.5°C to 0.0625°C	-40°C to 85°C	< ±0.2°C	1.25mA	\$9.95
TDK Thermistor	Analog	-55°C to 125°C	Translate voltage through lookup table	-	\$0.14

Barometric Pressure Sensor

- KP235 pressure sensor from Digi-Key
- Converts pressure between 40kPa to 115kPa into a voltage between 0.5V and 4.5V
- Typical atmospheric pressure is around 101kPa
- Accurate within 1.2kPa
- -40°C to 125°C operating range

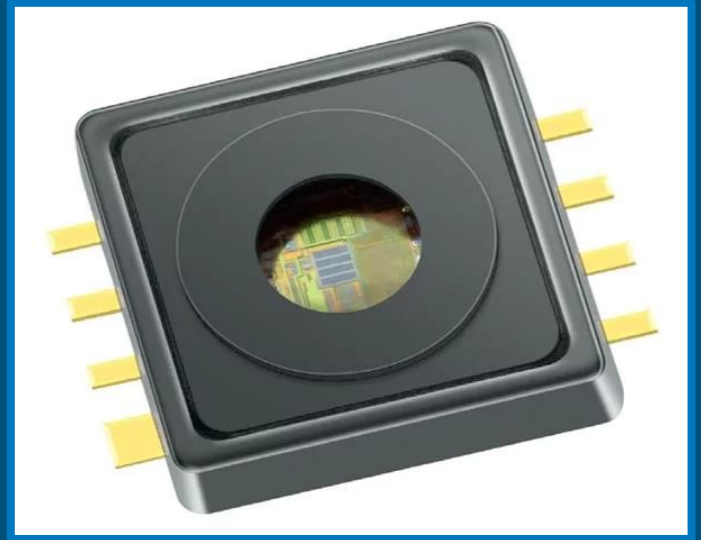

Water Level Sensor Comparison

Sensor	Sensing Range	Temperature Range	Current Consumption	Cost
HC-SR04	2cm to 4m	-	15mA	\$3.95
Resistive Strip	31.5cm	-9°C to 65°C	50mA	\$39.99

- As long as the strip sensor fits in the tank, it will measure any amount of liquid
- Ultrasonic sensor requires a minimum distance

Water Level Sensor

- We felt, despite the cost, the strip sensor benefits the project
- More accurate than ultrasonic sensor
- Easier to set up for users
- Keeping the ultrasonic sensor as backup

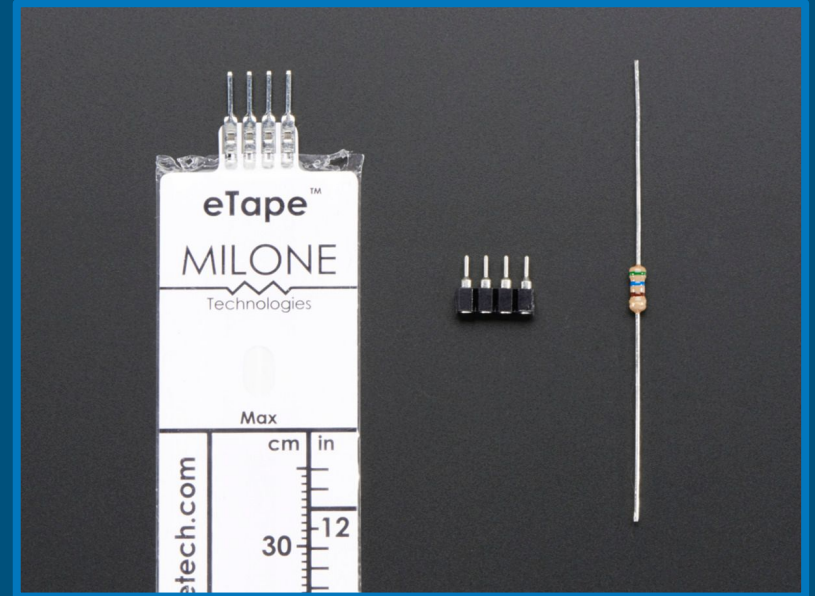

MCU Needs

Size:

- Small to reduce size of PCB

Price:

- Cheap to reduce overall cost

Ease of Use:

- Easy to Solder onto board

Control:

- Enough Memory for Code
- Enough GPIO pins for sensors(5+)

Low Power:

- Reduce the amount of drain on battery for a longer lasting device

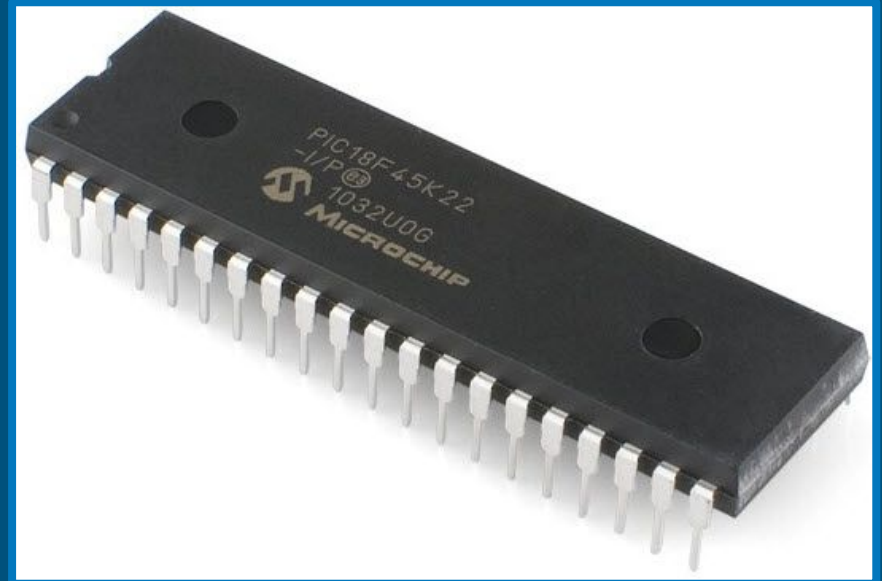

Microcontroller Comparison

	AT32UC3L0128	MSP430FR6989	MSP430F6659	ATmega328P	ATSAMG51
Clock Rate	50 MHz	16 MHz	20 MHz	20MHz	48 MHz
Low Power Mode	165 uA/MHz	101.25 uA/MHz	295 uA/MHz	.75 uA/MHz	103 uA/MHz
Cost	\$6.39	\$9.64	\$12.25	\$2.18	\$3.14
Memory	128 KB	128 KB	512 KB	32 KB	256 KB
GPIO	36	83	74	23	38
Communication Types	UART,SPI,I2C	UART,SPI,I2C	UART,SPI,I2C	UART,SPI,I2C	UART,SPI,I2C
Package Type	18 x 18 pin surface mount	18 x 18 pin surface mount	18 x 18 pin surface mount	DIP	18 x 18 pin surface mount

Atmega 328p

- Arduino bootloader
- Small DIP based chip
- Low power
- Fast clock rate
- Enough GPIO pins

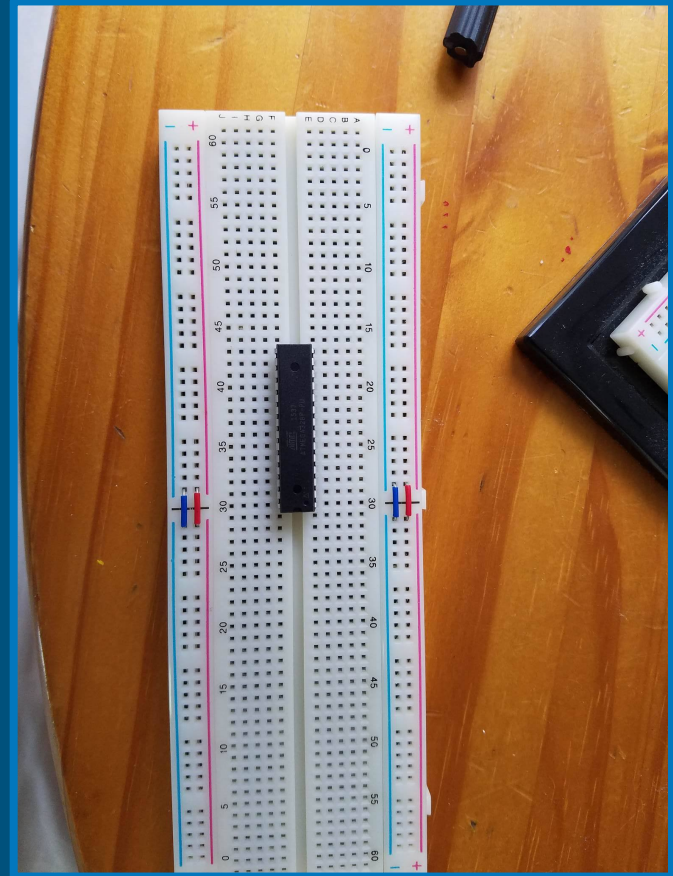

Pump Needs

Size:

- Small to reduce size of project Design

Price:

- Cheap to reduce overall cost

Voltage & Power Consumption:

- Low voltage to eliminate the need of a booster circuit
- Low power consumption to increase battery life

Flow Rate:

- High flow rate means better water distribution

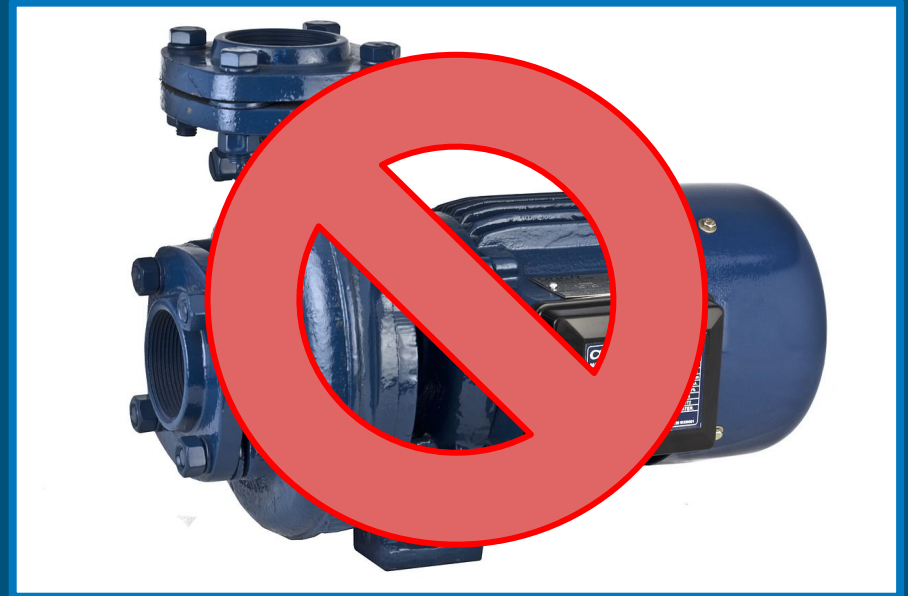

Pump Comparison

Pump	Voltage	Cost	Size	Gallons Per Hour	Power Consumption
Lightobject EWP-7L9	6-9V	\$8.95	30 x 78.3 x 10 mm	65 G/H	12W
Mavel Star 12 volt	12V	\$10.99	10 x 6 x 8.8 cm	63 G/H	6W
Anself Ultra-quiet Mini	12V	\$10.35	5.2 x 4.6 x 5.5 cm	63 G/H	4.8W
Unicliffe 80 GPH Submersible Water Pump	110-120V AC	\$7.99	53.3 x 43.2 x 33.02 mm	80 G/H	4W
3M Water Circulation Micro Brushless Water Pump	5-12V	\$12.00	50.8 x 45.7 x 55.9 cm	63 G/H	2W
FORTIRIC ZKWP01 60GPH DC 12V	12 V	\$10.99	51 x 34 x 42.7 mm	60 G/H	4.2W

Pump Selection

- Works with 5V
- 2W power consumption during operation
- No boost circuit needed
- Small and cheap
- Easy to install with screw brackets



Relay Circuit

Voltage & Power Consumption:

- Reduces power consumption with switching capabilities
- Uses 5V from battery to drive pump
- Uses 3.3V burst from GPIO to turn on
- Allows for a more efficient pump
- All current from second port of the battery goes directly to the pump

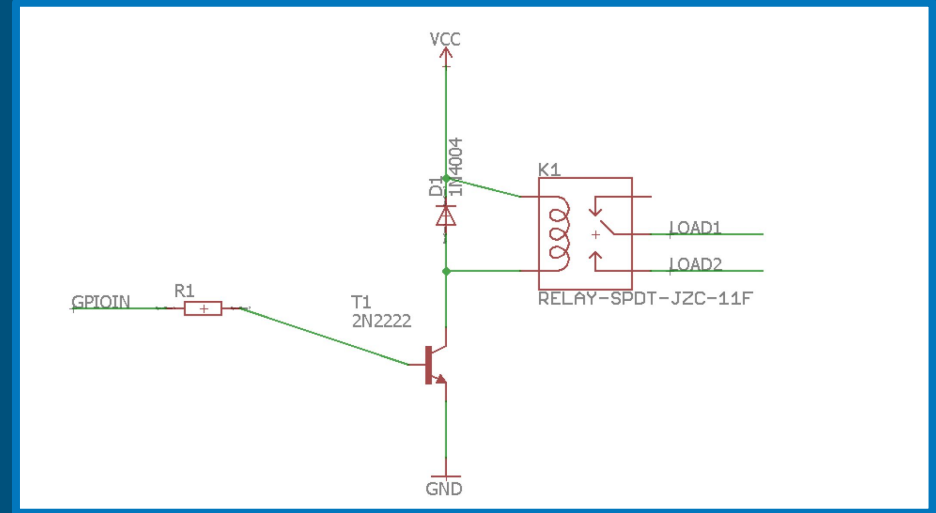

Voltage Regulator

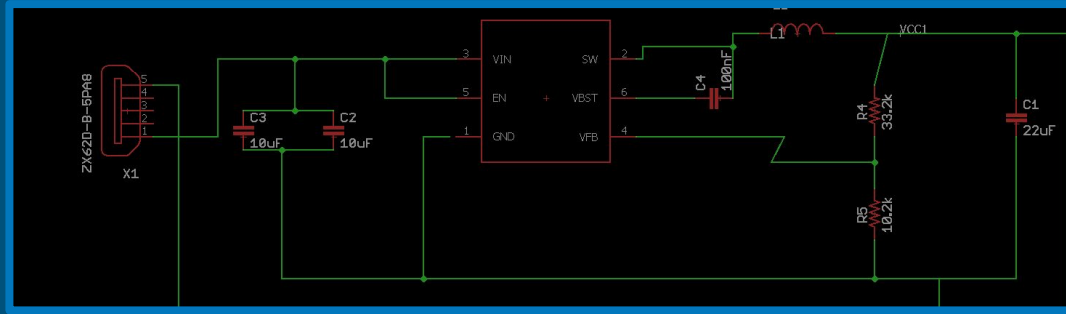

- 5 Volt DC input, 3.3 Volt DC output
- Can handle up to 7 Amps but takes in 1 Amp and outputs 1 Amp
- Handles the load from all 3 Sensors and MCU
- Uses resistors as a voltage divider to set the output voltage
- Uses the Texas Instruments TPS562200

Printed Circuit Board (PCB)

Speed:

- Fast turnover in case an error occurs

Layers:

- 2 or more to help with wire routing

Price:

- Cheap to reduce project cost

Customer Service:

- High rated in case we need faster shipment or damaged board comes in

	Price	Manufacturing Speed	Layers	Rating
4PCB	\$33	5 days	2	5 stars
PCBCart	quoted	1-5 day build + shipping	10	5 stars
Seeed Studio	quoted	1 day build + shipping	16	5 stars
PCBway	\$5+shipping	2-5 days	2	5 stars
OSHPark	\$26	5 days	2	5 star

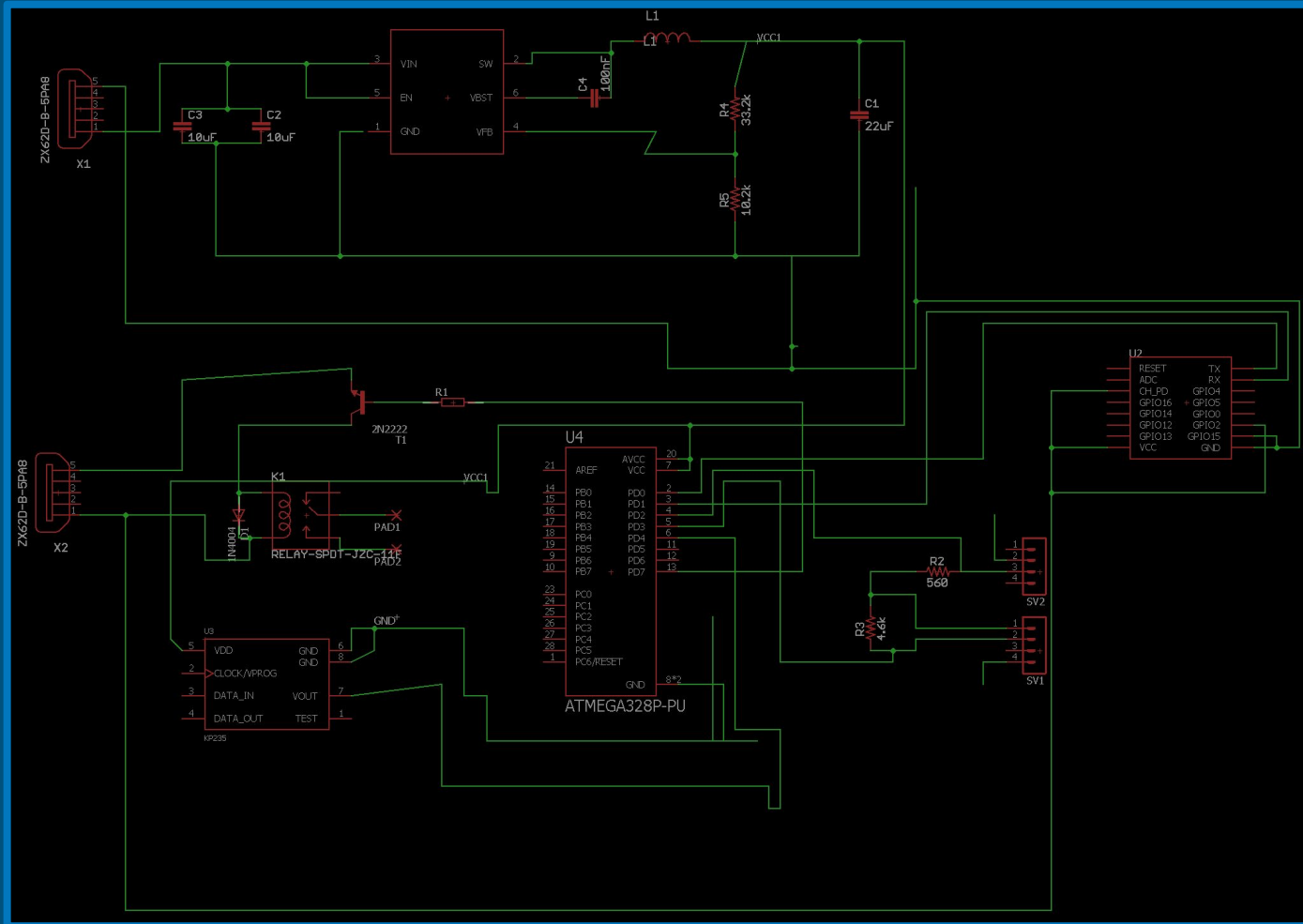

PCB Schematic

Hardware Testing

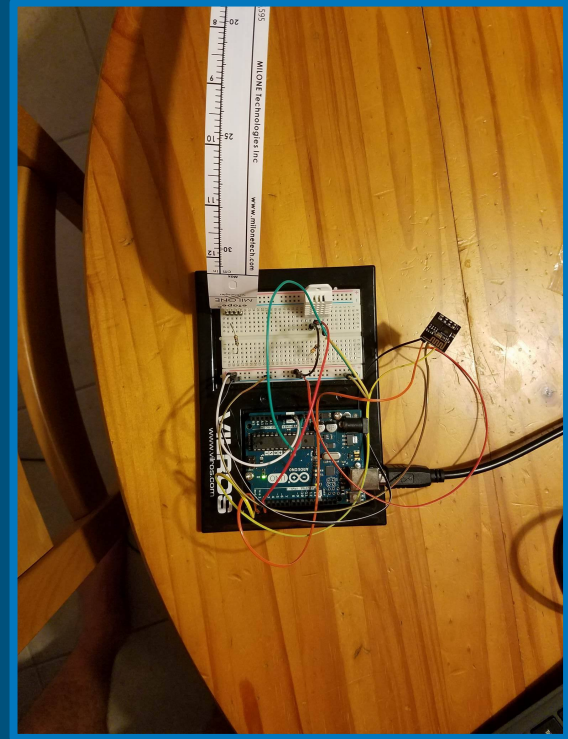
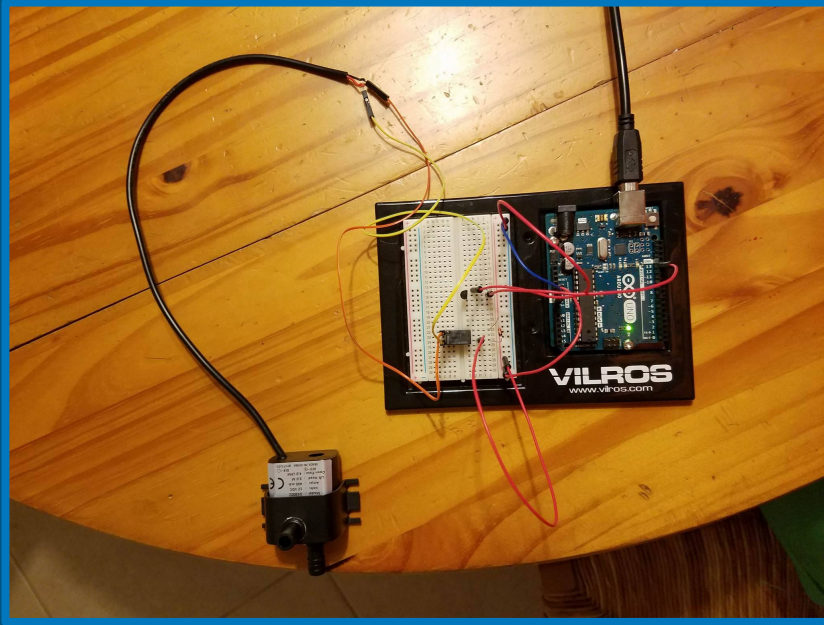

Wireless Communication

In order for the project to work, the device and its application must be able to communicate wirelessly

Technology	Advantage	Disadvantage
Wi-Fi	<ul style="list-style-type: none">- Provides high-speed access to the internet- Long signal range- Once device is connected to internet it can be operated from anywhere in the world	<ul style="list-style-type: none">- Harder to setup- Walls and other obstacles interfere with signal strength
Bluetooth	<ul style="list-style-type: none">- Easy to connect devices- Easier to implement in microcontroller environment	<ul style="list-style-type: none">- Only works over short distances (< 30 ft)- Cannot connect a device to the internet
ZigBee	<ul style="list-style-type: none">- Low cost- Low power- Encrypted network	<ul style="list-style-type: none">- Mainly works over short distances- Slow transmission speed

Wi-Fi Module Comparison

	Arduino Wi-Fi 101 Shield	ESP8266 Wi-Fi Module
Operating Voltage	3.3V and 5V	3.3V
Wi-Fi Standards Supported	IEEE 802.11 b/g/n	IEEE 802.11 b/g/n
PCB Connection	SPI Port	SDIO 1.1/2.0, SPI, UART
Size	2.1" x 2.5" x 0.93"	1.0" x 0.6" x 0.04"
Price	\$49.95	\$6.95

Although the Arduino Wi-Fi Shield had many more features and was a little easier to set-up, the ESP8266 had all the features we needed and was considerably cheaper

Smartphone Application

- Helps the user communicate with the device through Wi-Fi
 - Read sensor data and status
 - Modify settings
- Operating System: Android
 - iPhone platform was also considered but developing an application for iOS requires Xcode which is only available on Mac
- Application development software: Android Studio
- Initial testing conducted on Google Pixel Emulator

Sensor Status (Home) Section

- Default screen when application is launched
- Displays all relevant sensor data in one page
 - Humidity
 - Temperature
 - Pressure
 - Water Tank Level
- Easy way to determine if sensors are working properly
- Overall quick overview of the entire system

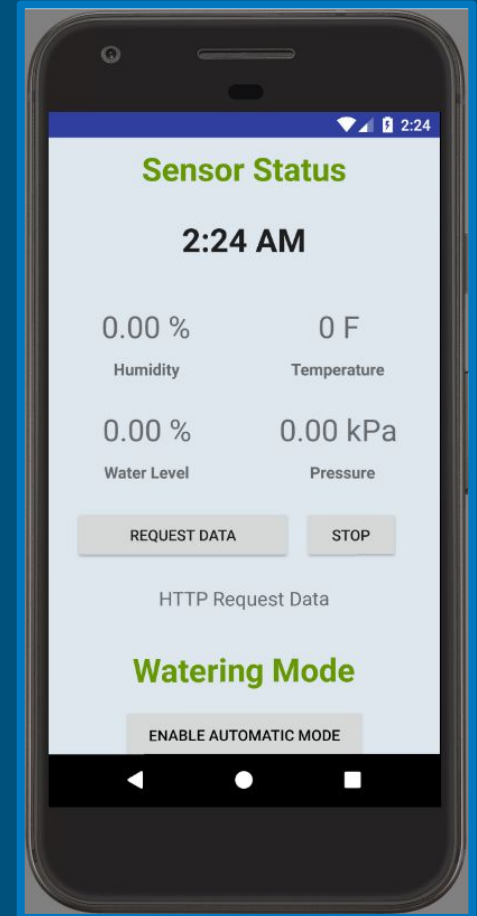

Watering Mode Section

- Enable /disable automatic watering mode
 - Uses all the onboard sensors to determine the best time to water the plants
- When automatic mode is disabled, manual mode settings become available to the user
- In manual mode, users have the option to water plants:
 - Every X amount of hours
 - At a certain time of day
 - When moisture drops below certain level
 - More can be added based on needs...

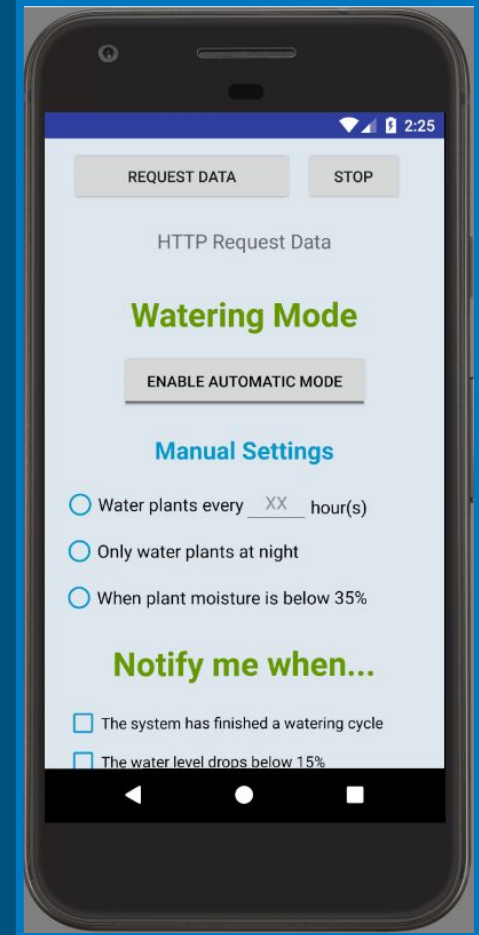

Notifications Screen

- Allows user to set up notifications for certain events
- Events include:
 - The water level drops below X %
 - Outside temperature is above X degrees F
 - The system has finished a watering cycle
- Still in development
 - More events can be added based on the needs of the user

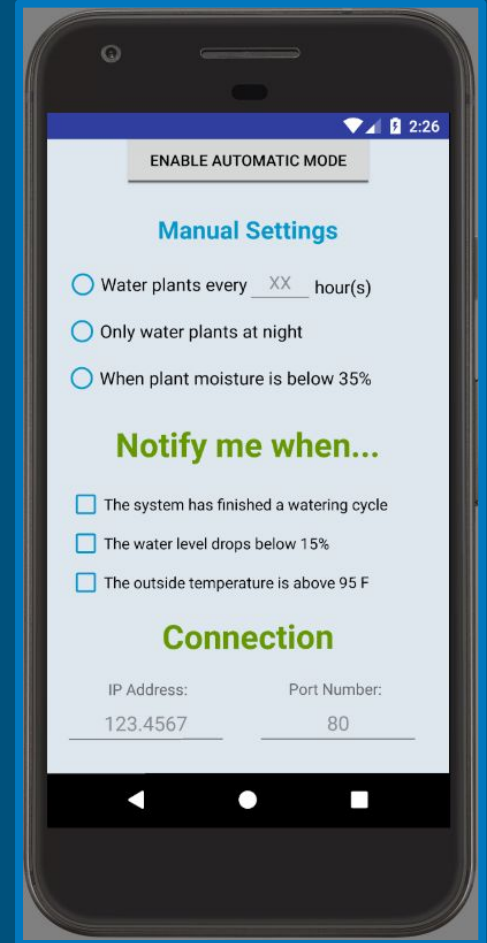

Use Case Diagram

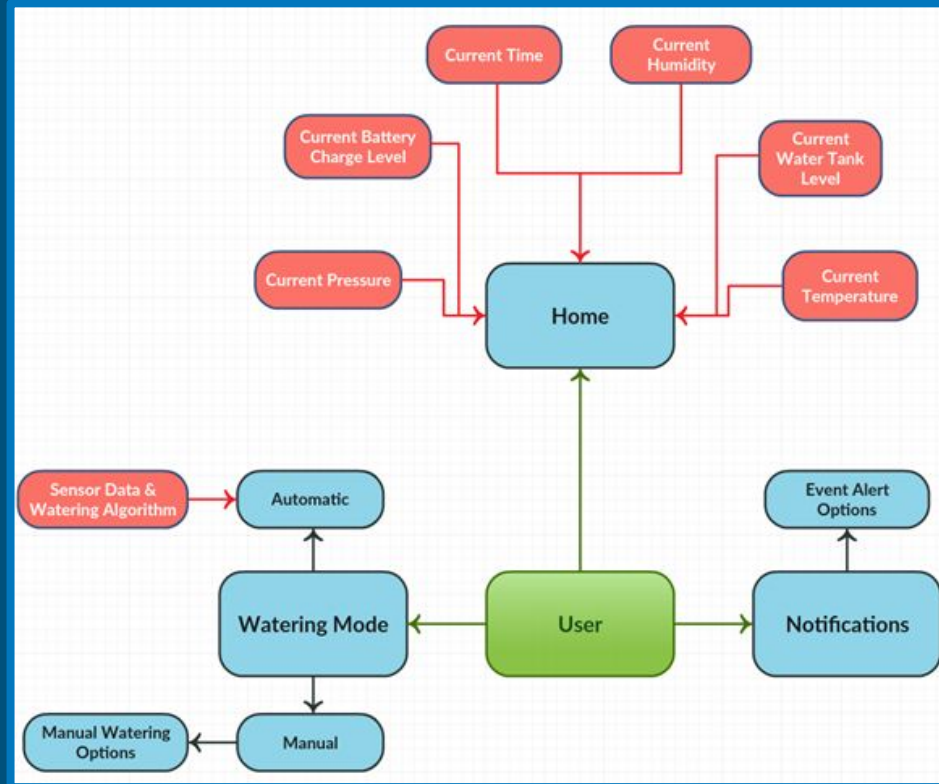

Device Prototype Sketch

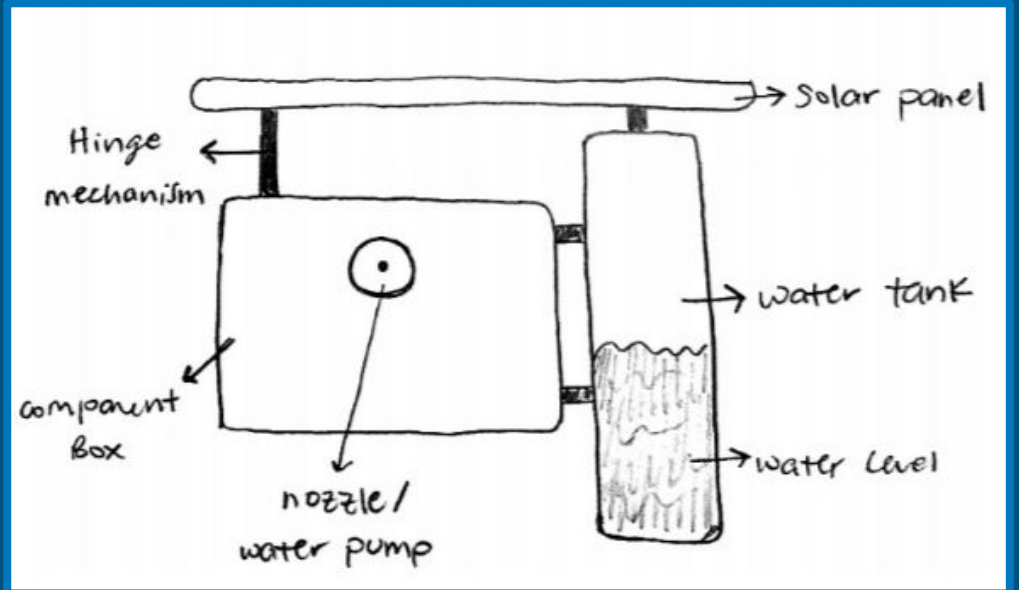
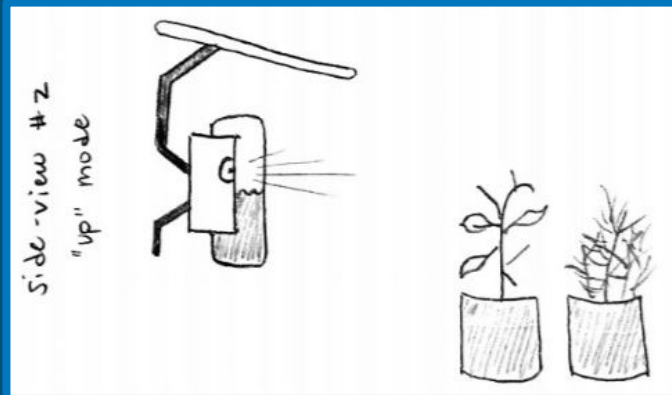
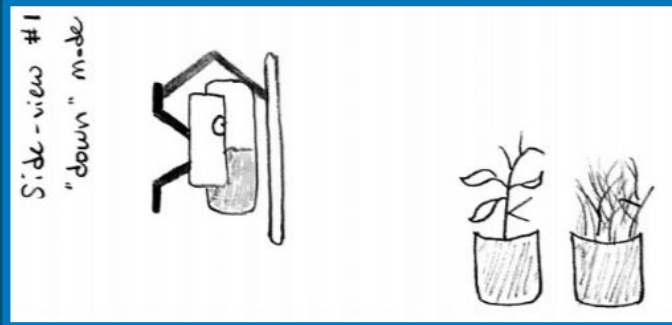

Issues Encountered

- Physical Design
 - Directing the solar panel to get enough sunlight
 - Placing the device in desired location
- PCB Design
 - Proper Routing
 - SMD soldering
- Software
 - Occasional garbage data transmitted

Budget & Funding

- Price per unit is going to be around \$ **295.50**
 - Only takes into account the price of parts currently on device
- Total amount spent so far is \$ **427.64**, which includes:
 - Needed components
 - Backup parts
 - Miscellaneous parts (resistors, capacitors, etc.)
 - Testing equipment
- This is not a sponsored project
 - Project funded entirely by the team
 - Total cost split evenly across the four team members

Budget & Funding

Component Name	Price	Source	Quantity Purchased	Amount Spent
Water Pump	\$12	Amazon	1	\$12
Solar Panel & Battery	\$159	Voltaic Systems	1	\$159
PCB	\$35	Oshpark, PCBWay	2	\$70
ATmega328P Microcontroller	\$2.18	Adafruit	1	\$2.18
Temperature & Humidity Sensor	\$9.95	Adafruit	2	\$19.90
Barometric Sensor	\$8.43	Digi-Key	3	\$25.29
ESP8266 Wi-Fi Module	\$6.95	SparkFun	5	\$34.75
Water Level Strip Sensor	\$39.99	Adafruit	1	\$39.99
Water Tank	\$2	Walmart	1	\$2
Miscellaneous Parts	\$20	Amazon	1	\$20
MSP430 Chip	\$1.33	Adafruit	3	\$3.99
3-in-1 Sensors	\$7.58	Digi-Key	3	\$22.74
Ultrasonic Sensor	\$7.90	SparkFun	2	\$15.80

Work Distribution

Team Member	Power	PCB	Sensors	Application
Chris		Secondary	Primary	
Joan			Secondary	Primary
Peter	Secondary	Primary		
Ronak	Primary			Secondary

Progress

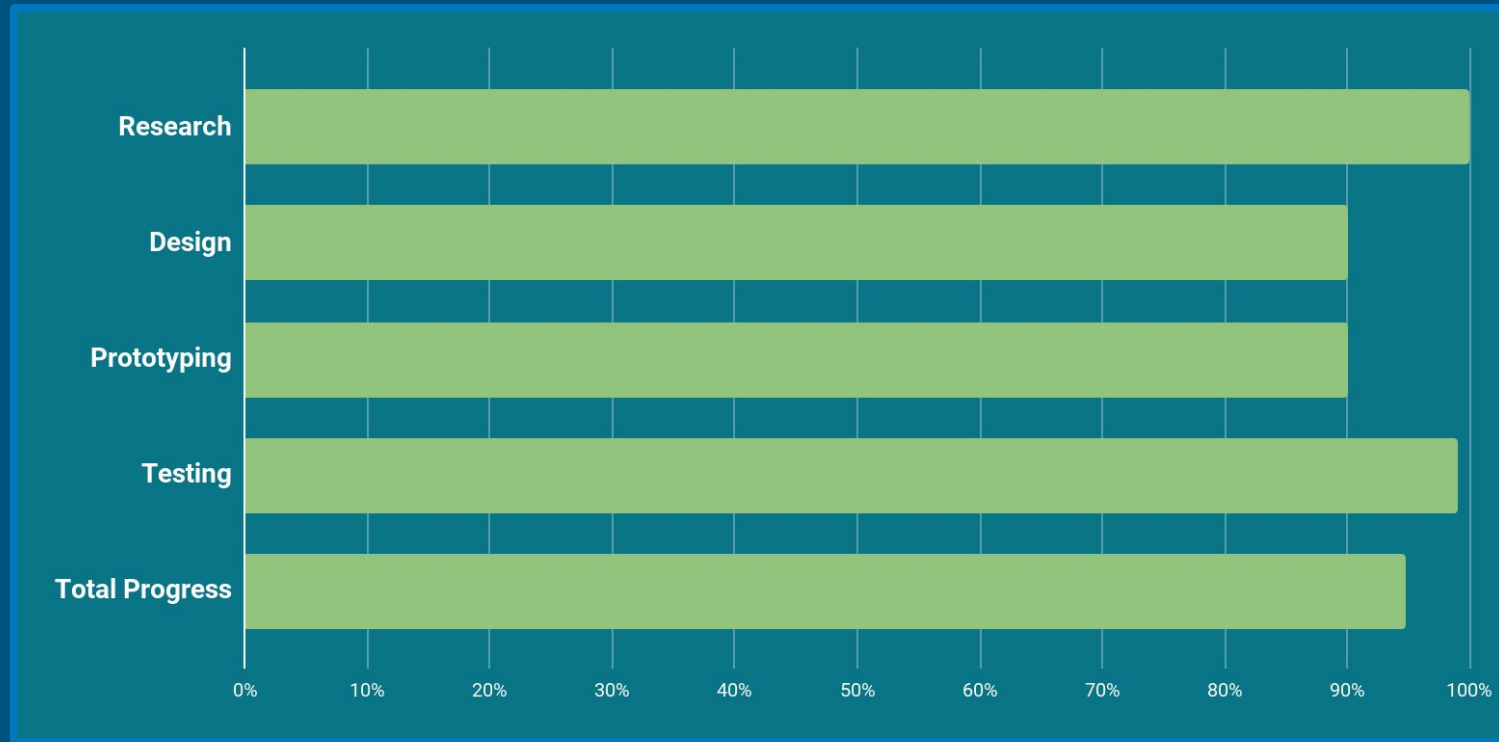

Any Questions?