

Senior Design I Document

EEL 4914



Edgar Alastre

Colton Myers

Jonathan Chang

Ashish Naik

Table of Contents

1.0 Executive Summary	1
2.0 Project Description	3
2.1 Motivation	3
2.2 Beer Pong History	5
2.3 Beer Pong Game Description.....	5
2.3.1 Setup	3
2.3.2 Gameplay.....	6
2.4 Objectives.....	5
2.4.1 TBD Central Controller Objectives	6
2.4.2 RGB LED Array.....	6
2.4.3 Impact Sensors	6
2.4.4 Cup Display System.....	6
2.4.5 Ball Cleaner	6
2.4.6 Power Supply.....	6
2.4.7 Smartphone/Desktop App	6
2.5 Requirement Specifications.....	5
3.0 Research Related to Project Definition	4
3.1 Existing Similar Projects	5
3.1.1 LED Dome Array.....	6
3.1.2 The DCPPTSS.....	6
3.2 Relevant Technologies	5
3.2.1 Pulse Width Modulation (PWM).....	6
3.2.2 Bluetooth	6
3.2.3 Serial Peripheral Interface Bus (SPI)	6
3.2.4 Persistence of Vision Display	6
3.2.5 Universal asynchronous receiver/transmitter (UART).....	6
3.3 Component Research	5
3.3.1 MCU	6
3.3.2 LED	6
3.3.3 LED Controller	6

3.3.4 Impact Sensors	6
3.3.5 Cup Display System.....	6
3.3.6 Shift Registers.....	6
3.3.7 Ball Cleaner	6
3.3.8 Power Supply.....	5
3.3.9 Smartphone /Desktop App.....	6
3.3.9.1 Smartphone App.....	6
3.3.9.2 Desktop App	6
3.3.9.3 Database	6
3.3.10 Table Building Material	6
4.0 Standards	4
4.1 Safety Standards.....	5
4.1.1 ASTM D2633-13a	6
4.1.2 ASTM D2395-14	6
4.1.3 ASTM D4442-07	6
4.1.4 ASTM E564-06(2012)	6
5.0 Realistic Time Constraints.....	4
5.1 Economic and Time Constraints.....	5
5.2 Health and Safety Constraints.....	5
5.3 Manufacturing and Sustainability Constraints.....	5
5.4 User Constraints.....	5
6.0 Hardware and Software Design Details	4
6.1 Initial Design Architecture and Related Schematics	5
6.2 MCU.....	5
6.3 LED Array.....	5
6.4 Impact Sensor Array.....	5
6.5 Cup Display System	5
6.6 Ball Cleaner.....	5
6.7 Power Supply	5
6.8 Smartphone App	5
6.9 Desktop App.....	5
6.10 Database.....	5

6.11 Table Construction	5
7.0 Prototype Testing	4
7.1 Test Environment	5
7.2 Test Components	5
7.2.1 MCU	5
7.2.2 LED Array.....	5
7.2.3 Impact Sensor Array.....	5
7.2.4 Cup Display System	5
7.2.5 Ball Cleaner	5
7.2.6 Power Supply	5
7.2.7 Smartphone App	5
7.2.8 Desktop App.....	5
7.2.9 Database	5
8.0 Administrative Content	4
8.1 Budget.....	5
8.2 Labor Division.....	5
8.3 Milestones	5
8.4 Group Member Information	5
9.0 Conclusion	4
Type chapter title (level 1)	4
Type chapter title (level 2)	5
Type chapter title (level 3).....	6

List of Figures

Cup Setup

Legal Shooting Range

(Holmes) Figure 3.5

(Holmes) Figure 3.6

(Holmes) Figure 3.11

(Holmes) Figure 3.17

List of Table

Tiva

SAM

AT91

Atmel

Texas vs. 3Atmel

1.0 Executive Summary

This document covers the project that group 13 (from now on referred as “the group”) is creating for their Senior Design Project. The name of the device that the group is creating is “**interactive beer pong table**” (**name to be determined**). The group chose this project to make a team-based game which involves precision skill by throwing a ball to a target more interactive and overall more enjoyable, enthusiast and beginners alike.

The game we are deciding to enhance is called water pong, popularly known as “beer pong.” The game consists of two teams, usually composed of two persons. Each team stands on the far end of a long table. The teams compete by throwing a ping pong ball into cups that are on the other end of the table aligned in the shape of a triangle. These cups are filled with a liquid in order to prevent them from falling once the ball gets inside of cup. The ball-throwing phase is turned based and once the opposing team “scores” by landing a ping pong ball inside of the cup the other team must remove that cup and drink the liquid inside of that cup. Once the two ping pong balls are thrown by one team, then is the other’s team turn to attempt to land the ping pong balls and once one team is out of cups on their side the opposing team is declared “winner.”

The purpose of the (**insert project name here**) is to make such a popular game with basic rules more interactive by adding more features to the most important part of the game which is the table. By making the table more interactive the players will be allowed to further enjoy the game.

The (**insert project name here**) will house many features. As a basic feature the table will be able detect when the ball bounces on the table and hence, detect when the ball has landed on a cup using a basic algorithm. The (**insert project name here**) will also be able to keep the score of the teams which could become a shore since these games are often played in crowded social environments.

The table of (**insert project name here**) will be regulation size which measurements 8 feet by 2 feet by 27.5 inches (L x W x H) which will allow the standard number of cups which are six on each side set in a triangular shape measuring 3.5 inches in diameter for the rim and 2.5 inches for the base and 3.75 inches high. The table will have sensors that will detect the presence of the cups along with a base to securely lock each individual cup. The aforementioned sensors will have RGB LED’s to create a ring around each cup which color will be user programmable and its primary function will be to notify the user whether the cup is placed. Optimally, the color of the aforementioned LED’s will change color if a cup is removed.

Furthermore, the entire table field of the (**insert project name here**) table will have a sensor field and a RGB LED array. Both of these will serve for an aesthetic appeal and a functional aspect. The purpose of the aforementioned sensor array

is to detect when a ball bounces any place on the field. This situation is called when player performs a “bounce shot” to land their targeted cup. Another possible situation could be when the player misses their shot and the ball happens to hit the field. The “sensor field will work in conjunction with the RGB LED array. The function of the aforementioned RGB LED array would be light up on the specific area where the specific sensor in the sensor field is activated. For instance, if the player performs a “bounce shot” a sensor will be activated and thus, would light up a RGB LED in that same location or area. The behavior of the RGB LED array would all be decided by the user. As of the writing of this document, the RGB LED array will have preset behaviors such as a ripple effect that would resonate through the entire table once the ball makes contact with a sensor. The ripple will be in different shapes. Additionally, another effect would be added where the RGB LED array would light up in patterns that simulate effects such as a plasma globe. Finally, another preset effect will be added where the RGB LEDs will react to the music being played.

The group will utilize several microcontroller units (MCU) for the completion of this project. A main ARM processor with enough power to control several slave MCUs. Most likely, a MCU will be required for the RGB LED array as well as one for the sensor field. The main MCU will most likely contain a wireless module in order to communicate with a smartphone for the players to configure the **(insert project name here)** to their desire. Furthermore, the main MCU will control the scoring aspect of the game as well as other key features such as team management, scoring, etc. All information will be sent directly to the smartphone.

Additionally, the table will have a feature that has always been neglected which is hygiene. Often, when the game is played, the ping pong falls to the ground and often collecting foreign particles such as dust and germs. The team solves this problem by adding a built-in ball cleaner that will not only dry the ball using pressurized air, but also free ball from all types of particles and a UV light that will potentially kill any germs thus making the game more hygienic while adding a better gaming experience since the ball will be perfectly dry during each turn.

Finally, the **(insert project name here)** will include a smartphone app that as mentioned in previous paragraphs, will control the behavior of the table. The smartphone app will be a critical feature as it will provide the players control of **(insert project name here)**. The smartphone app will allow players to set up a profile that will track progress of the players and provide a rank based on their performance. It will also allow the players to configure the behavior of the RGB LED array, set game mode and keep track of the game’s score.

2.0 Project Description

2.1 Motivation

The members of the group have in occasion gone to social gatherings such as house parties or tailgate as responsible, legal-aged adults. These gatherings involve the enjoyment and company of others as well the consumption of alcohol. While at parties the most common activities would include socializing, dancing, and the enjoyment of music there are also games involved which sometimes include card or board games, but in most cases the game is Beer Pong.

Beer pong is one of the most popular games in college parties and tailgating gatherings. It is part of the college culture and has been practiced for many years. As there are official rules, there are also very different play styles in different regions as it is a “cultural” activity.

Given the nature of Beer Pong, being a house-party activity. The equipment is often forgotten about. The team realized that usually the table is not looked upon, often hampering the experience of the game. Additionally, since house parties are not exactly events where organization is had. Often, when Beer Pong is played since there are so many distractions, teams sometimes lose track of which team has their turn, also there are queues problems as to which set of teams are next to play. Overall, Beer Pong can often become an inefficient experience given by the nature of a house-party organization.

The team also seeks to modernize the game by making it more interactive by integrating a system that keeps tracks of teams, players and their score. In these social gatherings, none of this information is collected as there is no technology available to store it. The creation of the app will address all of these issues by not only giving control of the players of how they want to customize the table, but by also giving the power of the player to show their performance to other team and players and to provide a more fair matchmaking during these social gatherings.

As aforementioned, the appeal of the table has been something forgotten about by many of the biggest table manufacturers. Beer Pong tables have been standardized for many years and barely any aesthetical changes have been made, but rather, portability has been the only improvement addressed. The team seeks to address the aesthetical aspect of the table by making **(insert project name here)** more visually appealing and interactive with the RGB LED array and the feedback sensors which will provide another layer of gameplay.

Additionally, the team noticed that often when the game is played a player may miss a shot that would result in the ball falling on the floor and ending up in places that accumulate foreign particles and bacteria such as under a table, furniture and so forth. As a result, the ball would accumulate some of these particles. The most popular solution is keeping a cup of clean water to rinse off the ball. Although

clever, the team has considered this an inadequate solution and seeks to solve it by adding a more complete cleaning procedure to keep the game more hygienic.

The members of the group additionally seek to improve their team working skills and expect to utilize the experience gained from previous electrical and computer engineering courses. The members of the group look forward to gain experience in app development as well as database management as it will required in creation of **(insert project name here)**. The app will provide many skills required today in the industry as it will require communication with another device and will share extensive information between the two. Additionally, the creation of the table will provide significant experience as it will require a smart design in order to administrate many components including an RGB LED array and a sensor field. Moreover, other aspects such as power management is vital in the development of **(insert project name here)** as the RGB LED array will require a steady supply of power.

2.2 Beer Pong History

Beer Pong is a game that has been practiced as early as the 1950's by many college fraternities. The origin of the game is unclear and given the nature of the game it is very difficult to determine the individual who came up with such a simplistic game idea. Although, it is said that the Delta Upsilon fraternity of Bucknell University claimed that they created a game that ultimately led today's Beer Pong. Delta Upsilon's version difference was the usage of paddles instead of just throwing the ping pong ball with one's hands. The objective was still the same as the player would have to use the paddles to direct the ping pong ball into the opponent's cup. After the 1970's the variant form of the game which included paddles was dropped and the game because was is today known as Beirut which is the paddle-less version of the game. Beer Pong has been popularized enough for enthusiasts to implement technologies in the table. Prototypes by various universities and hobbyists include tables that have a built in ball washed. Additionally, tables that have lighting that respond to certain frequencies.

2.3 Beer Pong Game Description

Beer Pong is typically a house-party game played by legal-aged adults as it involves consumption of alcoholic beverages. In this game, two teams go against each other and the objective is to remove the opponents' cups off the table by launching a ping pong ball across one team's side to the opponent team's side and landing the ping pong ball in the opponent team's cups. The winner is determined by eliminating all of the opposing team's cups. The following are the rules and regulations of house play (Rules - Drinking Beirut (Beer Pong), Rules- Official House Rules | BPONG, Rules-Typical House Rules | BPONG).

2.3.1 Setup

- A. Teams
 - a. Teams consist of two different players each
- B. Balls
 - b. Game requires at least 1 ping pong ball
 - c. Balls are considered unfit for play if they are cut cracked or dented and must be replaced with a ball fit for play
- C. Cups
 - d. A total of six cups are used to represent each team on both opposing sides of the table.
 - e. Cups are plastic and must contain a volume of 16 ounces each
 - f. The cups are each filled with between 3 to 4 ounces of a beverage to be chosen by those playing the game
 - g. The cups are arranged in the shape of a triangle with the base approximately 4 inches away from the end of the table. The following diagram shows how the cups should be arranged (Rules - Drinking Beirut (Beer Pong)):

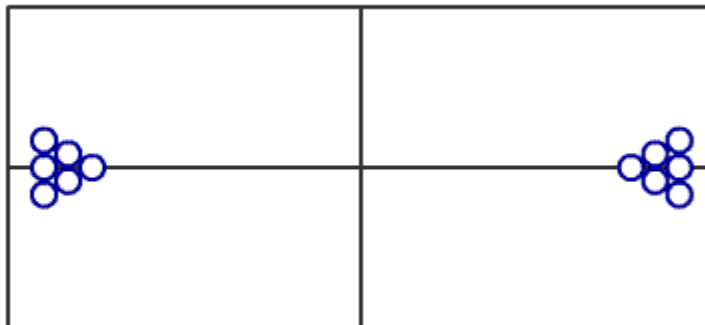

- h. Cups are considered unfit for play if they are damaged in a way that inhibits their use in game and must be replaced
- B. Table
 - a. The table used must be 8' x 2' in area and about 27.5" tall
 - b. There should not be any obstructions to play on the surface of the table
 - c. Spilled beverages on the surface of the table should be cleaned to insure fair play.
- C. Shooting Area

- a. The shooting area is bounded by the parallel edges running along the longest side of the table. Other than that, there are no boundaries on where a player can stand.
- b. Players are within legal shooting range as long as at least one foot is within the designated area. The following diagram highlights the area considered to be legal, relative to the table:

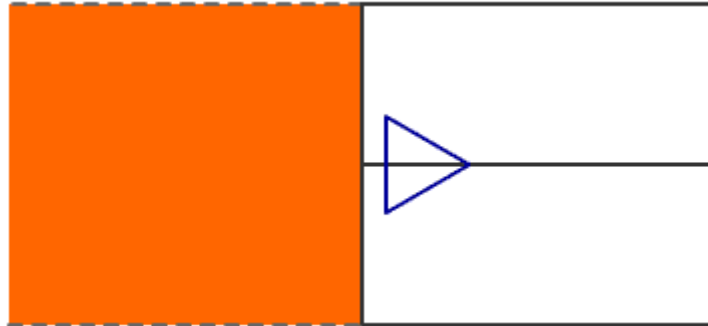

2.3.2 Gameplay

A. Shooting

- a. During each team's turn, each team shoots one ball. If a player shoots a ball and extend their arm their elbow shall not cross the table's plane. If a player makes a shot and lands an opponent's cup, then that cup is removed. If a player makes a show and misses then no cups are removed.

B. Offense

- a. The offense or "offensive team" is considered as the team that has the possession of the ball and that are in their right to propel the ball into the opposing team in attempt to land the ball in the opponents' cups. The offense team may shoot the ball in any fashion as long as they are positioned behind their side of the field and no teammate assist the other. The offense team may only lose control of the ball if their intention was not to shoot the ball. No cup penalty is applied if the offensive team land the ball on their own cups. However, if the offensive team shoot their ball and it slips into their own cups, the offensive team must turn over the ball to the defending team effectively ending their turn.

C. Defense

- a. The defense or "defensive team" is considered as the team that attempt to legally prevent the ball to land by the offensive team by blocking the ball after first contact has occurred. The ball's first contact occurs when the ball touches the surface of the table or a cup. The only legally acceptable methods of blocking the ball include catching, swatting, hooking, and blowing. To summarize, If the offensive team attempts a bounce shot, the defensive team may attempt to catch the ball once it makes first contact with the table's

surface. Additionally, if a regular shot is attempted by the offensive team and the ball happens to circulate around the cup, the defense team may attempt to legally block the shot by either blowing or using their finger to prevent the ball to enter the cup.

D. Bouncing

- a. During a player's turn, that player may bounce the ball on the table to land the ball on the opponent's cup. If a player makes a bounce shot and lands the ball then two cups are removed instead of one. The first cup removed would be the one containing the landed ball and the second ball is removed by the defending team's choice. Once the ball has made contact with the table. The defending team may block the shot once the ball has made contact with the table.

E. Elbow rule

- a. During each offensive team's turn. Players must keep their elbows and wrists behind the edge of their designated side of the table as their attempting to shoot the ball. If a player's elbow crosses their wrist or elbow the shot is deemed void and it must be re-made.

F. Re-Racking

- a. Any team can request to "re-rack," or re-arrange the cups during the beginning of their turn. This can only be done twice per game. Re-racking can only be requested when the amount of cups of any team is 6, 4, 3, or 2. Last cup can always be requested to be pulled back and centered.

G. Knocking cups

- a. If by any reason, even accidental, a cup happens to be knocked over. The aforementioned is considered "hit," or otherwise is assumed that a ball has landing on it and therefore that cup must be removed from the field.

H. Rebuttal and Overtime

- a. Given the occasion when the offensive team lands the ball on the last remaining cup of defensive team, the defensive team are allowed a final turn called "rebuttal" turn. During the rebuttal turn, the defensive team are allowed to attempt to land the ball on all the remaining cups of the offensive team. The turns are unlimited as long as all the cups are landed or "hit" consecutively. If a rebuttal is unsuccessful then the team's final cup must be removed and the opposing team is deemed winner. However, if a rebuttal is successful, the game goes to overtime. Overtime consist of three cups being placed bad in a triangular shaped on both sides of the field. The team that landed the last cup before the rebuttal phase are awarded the first turn. No re-rack is permitted during this phase with the exception of the last cup that may be pulled back and centered. Once the overtime phase ends the team that lands the last cup is deemed winner.

2.4 Objectives

2.4.1 TBD Central Controller Objectives

- TO BE DETERMINED MCU
 - Be able to transmit and receive data from TBD MCU to all its sub-systems.
 - Obtain data from motion sensor array system
 - Obtain data from cup sensor system
 - Send data pattern to RGB LED array to alter its behavior
 - Send/receive data to exterior system such as computer/smartphone
- RGB LED Array
 - Ability to turn on each independent RGB LED in the array
 - Ability to control color combination of each RGB LED in the array
 - Responds to input given by the sensor array sub-system in real-time
 - Sends preset patterns to signal different game events
 - Winner
 - Loser
 - Score
 - Team Logo
 - Cups Remaining
 - Game start countdown
- Ball/Object Sensor Array
 - Detect contact of objects and/or ping pong on responsive surface area of table.
- Cup detection
 - Ability to detect cups located in the table
 - Can correlate the detection of cup movement as an in-game event.
- Bluetooth Module
 - Used to Send/Receive data from the Smartphone App.
- Smartphone Application
 - Used to Send/Receive data to the Bluetooth Module

2.4.2 RGB LED Array

The RGB LED Array is one of most crucial parts of the (Insert project name here) as it will be the most visible result of our project design. It will need to be able to respond to commands from the MCU made in response to input from the touch sensor array as the user desires. In a way the RGB LED Array and the Impact sensor array will work as one unit. However, due to the way the system is designed it is essentially considered as an independent unit. The goal is to give freedom to the users to fully program the RGB LED array as they desire, however the team wants the user to utilize the RGB LED array as a measure to provide visual feedback from the sensors and a way to display many aspects of the game.

Objectives:

- Responds to input from the touch sensor array subsystem
- Fully programmable giving the ability to control each individual RGB LED in the array including luminosity and color.
- Energy efficient.
- Provide an aesthetic appeal.

2.4.3 Impact Sensors

The impact sensors, otherwise known as motion or touch sensor array, will need to effectively respond to the impact of the ping-pong ball and/or any foreign object on the "main" surface of the table. This information is then conveyed to the MCU as data to process and use for signaling the RGB LED array as the user desires. The inclusion of such sensors are essential for the project because they can signal many aspects of the game such as interference from any of the teams as well as players that want perform a bounce shot.

Objectives:

- Responds to contact on "main" surface of table, including when impacted by a ping-pong ball
- Conveys information to the MCU

2.4.4 Cup Display System

The purpose of the cup display system is to have more information about the game being sent to both the MCU and the smartphone/desktop app. Each side of the table will contain 6 sensors pertaining to the 6 cups that are required to play the game. The 6 sensors will also include its own independent RGB LEDs that will provide the user with visual information indicating that the cups are in place. The RGB LEDs will also be fully programmable to the liking of the user to provide information such as team color. The RGB LEDs and the sensors will function independently from the aforementioned RGB LED array and the motion sensor array which is why it is considered a separate sub-system. The sensors will be arranged in a triangular shape and the users will place the cups onto the available sensors as needed while still meeting the re-racking regulations of the beer pong game.

Objectives:

- Distinguish the presence of a missing cup and a placed cup.
- RGB LEDs exclusively activate to the presence of a cup.
- Respond from a removal of a cup during game session.
- Provide an aesthetic appeal.
- Fully programmable RGB LED for the users for aspects that include team color.

2.4.5 Ball Cleaner

Using a pressurized air pump and an ultraviolet light, we intend to construct a ball cleaner that will remove any debris and germs that have stuck themselves to the surface of the ball during play.

Objectives:

- Effectively removes debris from surface of ping pong ball
- Bathes ping pong ball in ultraviolet light to sanitize surface

2.4.6 Power Supply

Objectives:

- Required to power all of table's subsystems
- Required to be energy efficient

2.4.7 Smartphone/Desktop App

The purpose of the app is to allow the users to fully customize the table to their liking. In a way, the app is the bridge between the user's aesthetic preferences and the table. From the app, the users will have the ability to start the game, create teams, and customize the table. The app will also include a robust match-making system. The app will have a database with all the players that have played in the table and keep track of their progress. To engage communication with the app and the table, the smartphone and computer will utilize the Bluetooth capability of the table.

Objectives:

- Communicates with the table via Bluetooth.
- Provide matchmaking functionality.
- Allow remote customization of RGB LEDs for features such as behavior and color control.
- Receive sensor data from MCU for game-tracking purposes.
- Robust animation creator.
- Team logo creator.
- Tournament generator.
- Keep track of players' progress.
- User Friendly.

2.5 Requirements and Specifications

The group is required to have a set of accurate requirements and specifications which every member has agreed upon since it will provide the team realistic milestones to build and test the **(Insert project name here)** in an efficient manner.

The following is a list of requirements and specifications for the (**insert project name here**):

- (**Insert Project Name Here**) Requirements
 - Entire System
 - Able to play ten (10) consecutive games.
 - Able to withstand 10 ounces of spilled liquid without damaging any of the subsystems.
 - Subsystems
 - Central MCU
 - Able to handle at least ten (10) consecutive games of Beer Pong.
 - Able to independently drive 266 RGB LEDs from the RGB LED array subsystem.
 - Able to receive input from 266 Proximity sensors from the Impact sensor subsystem.
 - Able communicate via Bluetooth module with external subsystem
 - Able to drive at least two (2) MSP430s.
 - Able to communicate with six (6) RGB LEDs and six (6) Proximity sensors from the Cup Display Subsystem.
 - Able to store up to sixteen (16) different light patterns/routines for the RGB LED Array Subsystem.
 - RGB LED Array
 - Responds in real-time to input from the Impact Sensors
 - Allows up to sixty-four (64) different color combinations.
 - Able to display light-patterns for up to six (6) consecutive hours.
 - Impact Sensors
 - Able to detect a regulation sized ping pong ball in real-time.
 - Able to detect foreign objects in real-time.
 - Able to detect objects for up to six (6) consecutive hours.
 - Cup Display System
 - Able to detect up to six different cups on its sensors
 - Allow up to 64 different colors for the RGB LEDs
 - Responds to arrangement of cups in game.
 - Able to send sensor information to Smartphone/Computer app subsystem.
 - Ball Cleaner
 - Removes up to 90% of debris from regulation-sized ping pong ball

- Able to clean up to (2) balls at once
- Able to perform up to (100) cleaning routines consecutively
- Power Supply
 - Able to supply the (Insert Project Name Here) with 250W of power
 - Able to provide three (3) 3.3v, 5v, and 12v rails
 - Able to run continually for up to twelve (12) hours.
- Smartphone/Computer App
 - Allows remote customization of table

3.0 Research Related to Project Definition

3.1 Existing Similar Projects

Upon the initial research of the project. Many similar projects with similar functionality were research. This section will include the most notable and influential projects to our project. Only the most notable will be discussed as more than twenty projects and technologies were studied and discussing all of them would be redundant and inefficient.

3.1.1 LED Dome Array:

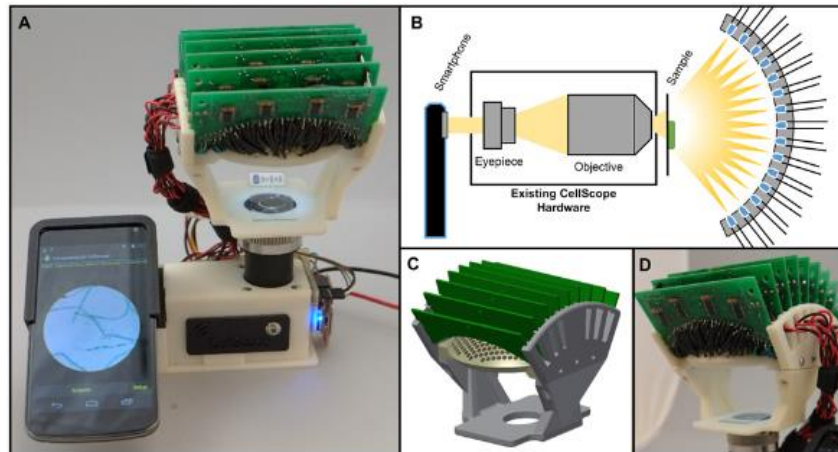

Computational CellScope. A. Device observing a sample using a Nexus 4 smartphone. B. Optical schematic of the CellScope device with our custom-made domed LED illuminator. C. CAD assembly of the dome. D. Assembled dome and control circuitry.

Copyright: © 2015 Phillips et al. This is an open access article distributed under the terms of the Creative Commons Attribution License, which permits unrestricted use, distribution, and reproduction in any medium, provided the original author and source are credited. (Phillips)

Of the features that our project is planned to include, the most obvious is an array of LEDs that will be able to form pre-designed patterns in addition to customized, user-input patterns. A similar system was implemented in another project involving a CellScope ("a low-cost, smartphone-based point-of-care microscope" (Phillips)) as a means of improving its existing hardware. Specifically they constructed a programmable dome of LEDs to cast light on a surface as a means of creating

improved imaging with the CellScope device. This project not only involves programming an array of LEDs, but also involves working with a smartphone app to control the system, both of which are relevant to our project.

This project is notable for making use of nine circuit boards that were each attached to four microcontrollers. The microcontrollers used specifically were the Texas Instruments TLC5926, and each set of 4 could control up to 64 LEDs at once. All of these microcontrollers were in turn controlled by a single Arduino Micro microcontroller that could receive input commands via an ordinary Bluetooth serial link. This design not only implements an advanced array of LEDs, but also makes use of an interface with a smartphone to take commands, which is another design goal that we are trying to implement. Given the similarities between these projects, it makes sense that we will use some of the available information on how they implemented this project to help implement ours. Specifically, this past project gives us reason to consider adopting their method of controlling the LEDs using similar, if not the same hardware. We can also consider looking into their power supply choices for our project since the one they chose was designed to “allow compatibility with a large range of power sources” (Phillips, pg. 9)

3.1.2 The DCPPTSS:

Another senior design project that was specifically built to be much the same as ours involved a limited number of LEDs that would respond to pressure input on the table from placing cups on its surface. It implemented the use of such hardware as 6 MSP430G2553 microcontrollers, 12 TLC5940 LED drivers, 46 5mW class 3b lasers, and 12 capacitive touch units, The microcontrollers give commands to the LED drivers on what patterns to take, while the laser grid and touch sensors provide input for the microcontrollers to respond to. Our project is meant to improve on theirs, so it is important to document the equipment and methods they employed so that we can keep track of any similarities and differences in our design. The use of specific microcontrollers and pressure sensors in their design lends reason for us to make use of the same, but while they chose to use a laser grid for theirs, we will most likely be using an array of pressure sensors instead. Having witnessed the documentation and functioning of their past efforts, we feel that we can improve on the design by implementing the use of more LEDs with more pressure sensors on the table. Having also seen their small control panel for giving commands to the table, we will attempt to implement a smart-phone interface to operate it instead. Thus, our design will mostly be made to improve on this past design (Braun).

3.2 Relevant Technologies

3.2.1 Pulse Width Modulation (PWM)

An excerpt from the book, *Pulse Width Modulation For Power Converters*, made the following statement, "One of the most widely utilized strategies for controlling the AC output of power electronic converters is the technique known as pulse width modulation (PWM), which varies the duty cycle (or mark-space ratio) of the converter switch(es) at a high switching frequency to achieve a target average low-frequency output voltage or current," (Holmes, pg.95). To put this in simpler terms, it is possible to reduce the amount of power utilized by a device by sending power to it in pulses at a lower frequency rather than constantly running power through them. Though the device may not appear to function any differently to a common user, this technique allows for significant reduction in energy usage. As such, we will be attempting to implement such a technique into our design to make it as efficient as we can.

According to the afore-mentioned book, "In Principle, all modulation schemes aim to create trains of switched pulses which have the same fundamental volt-second average (i.e., the integral of the voltage waveform over time) as a target reference waveform at any instant," (Holmes, pg.96). The difficulty with creating these regular, controlled pulses of energy is that there are "unwanted harmonic components" (Holmes, pg. 57), which are a kind of unwanted warping of the output signal. To minimize the occurrence of these distortions, it is necessary to run calculations on when to send the pulses so that they will be kept down. As such, there are two objectives to keep in mind when trying to use Pulse Width Modulation: the primary objective, achieve the desired low-frequency output; and the secondary objective, reduce the occurrence of harmonic distortion (Holmes, pg. 96). There have been a surprisingly large number of attempts to understand this technique, but there are only three different techniques for achieving PWM: *naturally sampled PWM*, *regular sample PWM*, and *direct PWM*.

The first method, *naturally sampled PWM*, involves comparing a "low-frequency target reference waveform (usually a sinusoid) against a high-frequency carrier waveform" (Holmes, pg. 105). This is accomplished by using either a triangular or saw tooth waveform to help create a function that will predict the points in time that switching can occur to best achieve the objectives of PWM. The book includes graphs to illustrate when switching is supposed to occur (Holmes, pg.107):

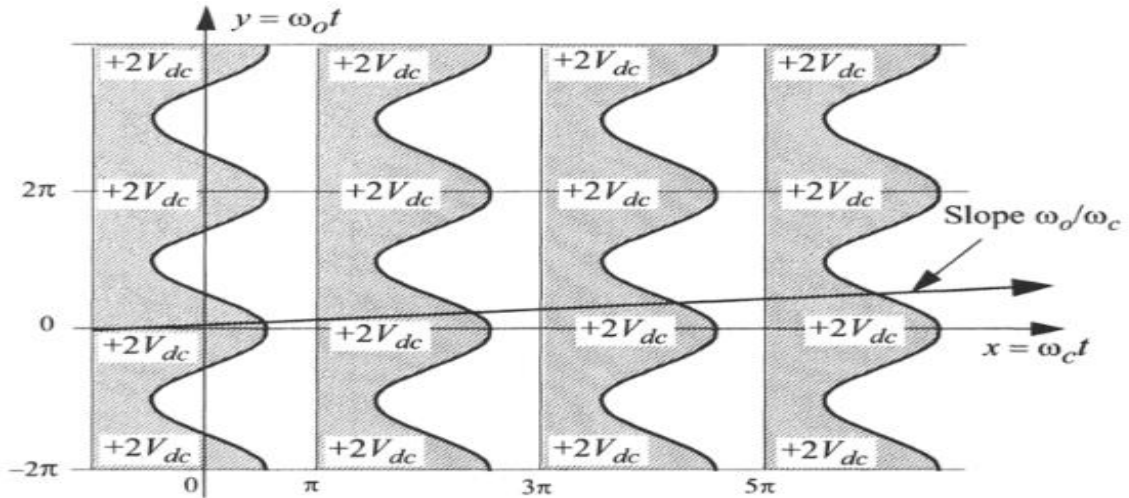

Figure 3.5 The x,y plane for trailing edge sawtooth modulation showing solution for particular values of ω_o and ω_c .

In this example, they are switching between 0 and $2V$ according to the nature of a sawtooth waveform for reference. Switching from 0 to $2V$ occurs at $x = \pi(2p-1)$ and from $2V$ to 0 occurs at $x = \pi(2p) + \pi/\cos(\omega_o t)$, where p is the value of the current pulse being examined (Holmes, pg. 107). The sloped line in the graph (ω_o/ω_c) intersects with the waveforms at the points where switching occurs. The following graph correlates the above to input pulses (Holmes, pg.108):

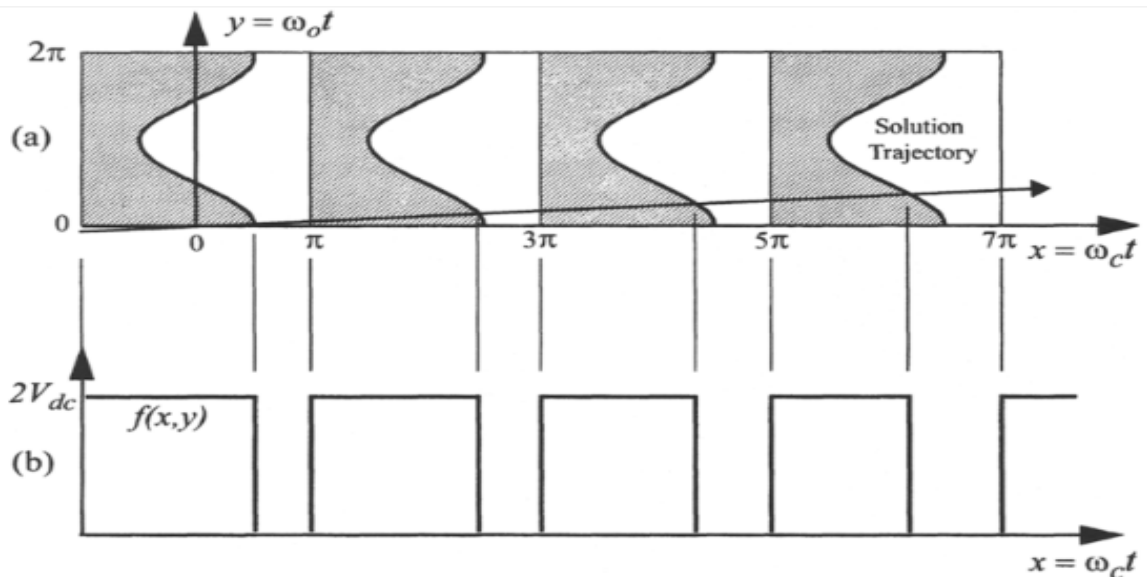

Figure 3.6 Half-bridge switching for *trailing edge* PWM: (a) x,y plane showing intersection of reference with unit cells and (b) x,y plane showing resulting PWM voltage.

The alternative to this technique is to use a triangular waveform with slightly different equations. Using the same two voltage points of 0 to 2V, switching from 0 to 2V occurs at $x = 2\pi p - (\pi/2)(1+M\cos(\omega_o t))$ and from 2V to 0 occurs at $x = 2\pi p + (\pi/2)(1+M\cos(\omega_o t))$ (Holmes, pg.115) :

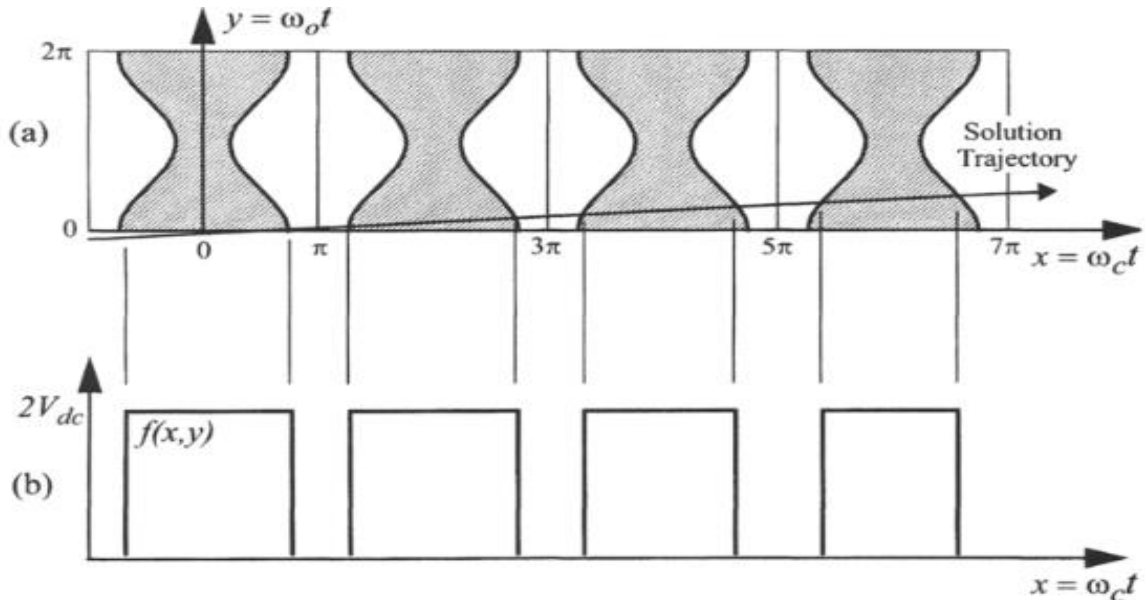

Figure 3.11 Half-bridge switching for double-edge PWM: (a) x, y plane showing intersection of reference with unit cells and (b) x, y plane showing resulting PWM voltage.

In either case, *naturally sampled PWM* is considered to be the easiest of the three techniques to use and implement, with the use of a triangular waveform in its implementation being more common. However, there are supposed to be difficulties using it in a digital modulation system because of its complex calculations. To avoid this problem, we move on to the next method, which is *regular sampled PWM*.

Regular sampled PWM is considered a popular modern alternative to the previous method. It is described as, "where the low-frequency reference waveforms are sampled and then held constant during each carrier interval. These sampled values are compared against the triangular carrier waveform to control the switching process of each phase leg, instead of the sinusoidally varying reference," (Holmes, pg. 125). To put this simply, we use the same basic technique from *naturally sampled PWM*, but it has been modified slightly so that, rather than trying to build a model that will create a "solution trajectory" which intersects with a smooth waveform, it will intersect with a stair-step waveform. The illustration below shows the use of *regular sampled PWM* on a saw tooth waveform. Take note of the stair-step shape that differs from the previous example (Holmes, pg. 130) :

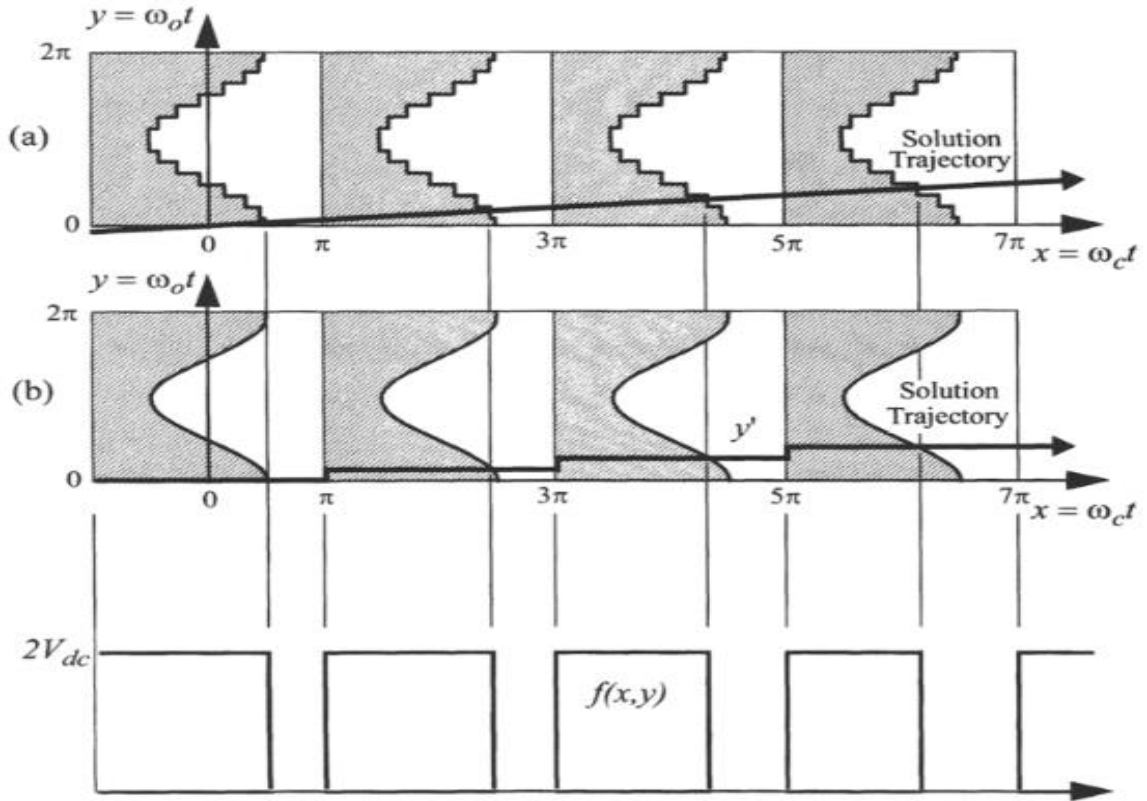

Figure 3.17 Half-bridge switching for trailing edge PWM: (a) sampled sinusoidal reference waveform and (b) solution trajectory held constant within each carrier interval.

This simple change in technique causes harmonic interference to change in phase, but more importantly, is easier to track because it involves looking for intersections between a stair-step waveform instead of a sine wave. Thus, this solves the problem of trying to intersect with a complex equation like those used in *naturally sampled PWM*, and can be realized with either a saw tooth waveform or a triangular waveform, each with a unique equation to be solved. Specifically, the *regular sampled PWM* technique uses the following equation (Holmes, pg. 128):

$$A_{mn} + jB_{mn} = \frac{1}{2\pi^2} \int_{-\pi}^{\pi} \int_{x_r}^{x_f} 2V_{dc} e^{j(mx + ny)} dx dy \quad (3.58)$$

where x_r = instant at which phase leg switches to $2V_{dc}$

x_f = instant at which phase leg switches back to 0 V

Sawtooth waveforms use these variables:

$$x_r = -\pi \quad x_f = \pi M \cos \omega_o t \quad (= \pi M \cos y)$$

Triangle waveforms use these variables:

$$x_r = -\frac{\pi}{2}(1 + M \cos \omega_o t) \quad x_f = \frac{\pi}{2}(1 + M \cos \omega_o t)$$

The third method of implementing PWM is "*direct*" PWM. The book describes this method as, "switch the inverter to create an active pulse interval for each carrier interval that exactly achieves the same volt-second average the original target waveform, " (Holmes, pg. 147). This method is actually very similar to *regular sampled PWM* in terms of the results it can produce. The distinction between the two lie in how the pulse width is calculated, causing them to vary in size between the two. However, there are few practical applications of this specific technique as it has few benefits to use and there are better ways of implementing PWM available. As such, we will likely not be using this technique.

Overall, PWM is a technique requiring strong mathematical skill to implement and control, but which ultimately comes with the advantage of getting our device to function more efficiently. We definitely want to make sure that it doesn't use more power than is needed, so this will be important to consider in our design. Out of all of them, *regular sampled PWM* seems like it would suit our purposes best since it can be easier to calculate than *naturally sampled PWM*, and we won't be using *direct PWM* because there don't seem to be any advantages to its use over the other methods for our purposes.

3.2.2 Bluetooth

Part of the plan for our project design is to include a means of interfacing with the table via Bluetooth so that the table's patterns and settings can be adjusted remotely. Bluetooth is a modern, wireless, low-power, and low-cost communication technology that can allow our table to communicate with a smartphone. The security that Bluetooth offers is often compared to that of wired networks, and the range it has is adjustable with a minimum value of 30 feet. It can transfer data at about 2.4 GHz using a full duplex signal (meaning it can send information both to and from a source on the same channel at the same time) and was adapted to be able to avoid interference from other wireless devices using adaptive frequency hopping (AFH) techniques.

Other than this, our option to connect our table with people's phones was to use the Internet, but it seemed like it would be detrimental in the event that an internet connection was unavailable. It was specifically decided that our design should enable people to customize the table settings without an Internet connection, if necessary. Furthermore, Bluetooth can automatically communicate with other Bluetooth enabled devices, so it would be easier to use by comparison. With that

in mind, it was clearly evident that Bluetooth was the best technology to facilitate our communication needs.

3.2.3 Serial Peripheral Interface Bus (SPI)

This technology is used to allow a microcontroller to communicate quickly with nearby peripheral devices or even other microcontrollers. Our project will require a custom-designed circuit board to connect our chosen microcontroller to its peripherals, so naturally we will be making use of this in our design. It was developed by the Motorola company before becoming more common in the world of electronics and is comprised of a “simple 4-wire serial communications interface used by many microprocessor/microcontroller peripheral chips that enables the controllers and peripheral devices to communicate with each other” (SPI interface in embedded systems). The SPI also has full duplex capabilities and was inherently designed for high-speed transfer, which relates to why it can’t be very long in length or else it overheats. A simple technology, but vital for our project.

3.2.4 Persistence of Vision Display

3.2.5 Universal Asynchronous Receiver/Transmitter

3.3 Component Research

3.3.1 MCU

3.3.1.1 Main Microcontroller

The main microcontroller is a very important choice for the project as is required to meet all the requirements to correctly drive every single component that will be attached to it. The main microcontroller will have the following components attached:

- LED Array
- Impact Sensor Array
- Bluetooth Module
- Cup Display System

Upon the decisions of the microcontroller, many aspects had to be studied. Aspects include available memory, number of inputs and output pins, and the clock speed. The microcontroller has to meet all the required criteria since it needs to provide the players the most real-time experience when communicating with the LED array and Impact sensor array to provide real-time animations as well as sending real-time score information to the Bluetooth module which then will be sent to the smartphone. Therefore, the microcontroller must have enough flash memory to store all the code in order to successfully execute all of the tasks.

Memory

Based on our research, many discoveries were made. Initially, the team began researching basic projects that involved the usage of sensors and LEDs, hence, at a point, it was determined that only a basic microcontroller with a small amount of memory was required. During this point, the team determined that only a basic 8-bit AVR processor with only 32 kilobytes of memory would suffice the project capabilities. However, when the team further studied more complex projects, the team came in realization that the features in plan were disproportionate for the code required to power such features. Therefore, the team evaluated the code in accordance to the features that were set for this project. The table will require to store an initial code that will require to initiate the table in a default mode that was previously set by the last code that was sent to the table by a smartphone. In other words, the table have the ability to perform a normal operation without the requirement of being connected to the Bluetooth device, such as smartphone, tablet, computer, etc. The requirement of memory must be of enough memory to await for the table to receive a communication with a smartphone and as well to have its sensors awaiting to be activated to therefore animate the LEDs accordingly. Additionally, the table will engage in a mode that will involve direct communication with a Bluetooth device as previously mentioned which will give

the users the ability to change the behavior of the table and most importantly, update scoring information of the current game session. Therefore, further increasing our memory requirement. The first project that truly established a memory limitation were the Beer Pong tables with similar functionality as the one that team is attempting to develop. Most of these tables utilized a 16-bit microcontroller of either PIC or AVR architecture with at least 128 kilobytes of memory. The tables studied had a code that controlled many aspects such as providing the user the ability to cycle through a set of animations using an infrared remote control in addition to displaying mentioned information through a small LCD display that additionally displayed information such as game score, etc. The tables also included some sort of sensor array that detected the presence of cups. Therefore, the team determined that 128 kilobytes was the minimum requirements for the table to run most the features initially planned. However, one aspect of these tables that did not fully meet our criteria was that most of these tables featured some sort of LED Array that was not RGB. One of the aspects of our code is that it will require to have information of not only black and white animations but also color. Colors immediately increase code size because more values are stored in some sort of array format come in the size of 3 colors which is completely different that running a single color that the microcontroller only interprets as on or off. RGB LEDs on the other hand require 3 times more the information to run a single LED, therefore, increasing the size of the code in such a substantial amount. Additionally, most of these tables did not involve some sort of sensor array that detected objects real-time across the entire table in addition to a cup sensor array which in terms of sensors is the only feature that our table shared in common. These unattended features created uncertainties that would require the team to further investigate other projects that involved large RGB arrays and sensor fields. The initial projects investigated with the aforementioned criteria involved a table that met most of the criteria as its microcontroller involved driving a decently sized RGB LED Array that reacted in real-time to a sensor array that created animations and such. The memory size required for the tables increased as the number of RGB LEDs in their arrays increased as well as the sensors. The first table investigated involved 100 RGB LEDs as well as 100 infrared proximity sensors and the featured microcontroller already required 256 kilobytes of memory which is already double of what was previously pre-set. Additionally, the aforementioned project involves driving an inferior number of lights and sensors than what was required by our project so that lead to further investigation. The second table had an even higher number RGB LEDs, almost five times in numbers. However, the microcontroller powering this table involved a microcontroller of a marginal performance increase. The microcontroller had the same amount of memory, being 256 kilobytes and its only difference was the architecture which was 32 bit ARM. The only unattended features now were that these tables often had very basic functionality or that the only work required by the microcontrollers was to send inputs to the RGB LED array and receive from the sensors. All of the animation and logic processing was done by a much more powerful device such as computer or smartphone which meant that most of the code was not stored on the memory of the microcontroller itself which lead the team to uncertainty as to

how much memory is required to fully have all the code with animations included in the table without the need of an external device such as a computer or smartphone. Therefore, the team investigated projects that involved a magnitude of intensity in every aspect which lead to the research of the microcontroller that powered projects such as 3D RGB LED cubes. The studied cubes involved driving a substantially higher number of RGB LED and additionally stored all of the animation information inside of the built-in memory storage of the microcontroller as well as having the ability to interact with exterior devices such as a smartphone or input controller. The microcontrollers involved in these projects were either AVR or ARM based with 256 and 512 kilobytes which is around the same required for the tables researched. Therefore, the team determined that to accomplish animations and smartphone interaction 256 kilobytes is more than enough required for all of the planned featured. However 512 kilobytes would give us more freedom but it wouldn't be a must-have requirement for our microcontroller choice.

Clock Frequency and Architecture and IDE

For the team's project. Clock frequency was not the most important aspect of the microcontroller. However, the team wanted the microcontroller to have an architecture that was easy to program for and had a vast resource library. Having a complex architecture implies having to initiate or "build" an initial platform under assembly code. The group has experience with the Texas Instruments IDE with the MSP430 and the Arduino IDE. However, the team would like to have additional experience with other microcontrollers and other IDEs. The frequency required is not that relevant. Since the processor will not be doing anything sound related, it does not require to have at least 44.1 megahertz which is the minimum required to produce sound. Therefore, the minimum required would be at least 32 megahertz which correlates to a processor that has the same memory requirements that we previously set on the memory section. Many of the manufactures studied included Atmel, Microchip Technology, and TI. Each of these companies flavored its own type of IDE. Upon the studies done of the previous projects, the team noticed that the most utilized microcontrollers were from Atmel due to their C/C++ compiler. However, Texas Instruments also have a very good IDE called Code Composer which also allows the user to code in C/C++. The group ultimately wanted to have a microcontroller that would allow direct programming using C/C++ as is the language the team has most knowledge and feels more comfortable with. Since all companies considered had AVR and ARM architectures available and also allowed C/C++ programming, none of these categories determined a deciding or limiting factor, instead, the architectures were evaluated in their way to save space and store memory. TI processors come in both 8-bit and 32-bit as well as AVR. 8-bit processors come with up to 384 Kbytes of memory. However, ARM processors which are the favored only come in 32-bit and 64-bit. In theory, having processor that has fewer bits allows a better usage of the memory as it takes less bits per instruction. Therefore, for our purposes, the best choice is a simple 8-bit processor. However, the memory options for all the candidates considered limit that selection.

Inputs and Outputs

The I/O or input and output requirements are also not profoundly relevant upon the selection of the team's microcontroller. The microcontroller needs to have enough input and output pins to suffice the RGB LED array, Bluetooth module, and sensor array. Although the microcontroller in essence will drive a high number of inputs and outputs it will not require to have a high number of input and output pins since the way that the team has designed the table most of the components will be connected through components that allow the utilization of fewer pins in order to control a high number of inputs and outputs. For instance, the RGB LED array and sensor array will be powered by ICs such as LED Drivers and shift registers since not a single microcontroller considered has a remote amount of input and output pins to directly control these devices. With all aspects considered, if a UART design is chosen the team requires main output pins to the RGB LED array, sensor array, and Bluetooth module. 6 pins are required for the RGB LED array and an approximate 6 for the sensor array. Pins include VCC and ground so in a sense the two main components do not consume a total of 12 pins as some of these are shared between the two. The Bluetooth, on the other hand, require 1 transmit pin and 1 receive pin along with power and ground. Therefore, an estimated 14 input and output pins are required as the only component powered by the microcontroller would be the Bluetooth module and the other two components powered by the power supply.

The ultimate decision was presented when the team compared the available microcontrollers on the market. The maker did not really come in consideration as the most important aspect of a microcontroller would be the architecture followed by the maker and not the other way around. Ultimately, the team had to decide between AVR and ARM architecture. Atmel specializes on AVR architecture but also have ARM options available. The AVR options available that Atmel produces come with memory sizes up to 512 kilobytes, up to 66 megahertz clock frequency and allow from 48 to 144 input and output pins. ARM options, on the other hand go from 128 kilobytes to 2 megabytes of memory and up to 120 megahertz operating frequencies which far exceed our requirements, ARM microcontrollers, as noted, are also manufactured by popular companies such as Texas Instruments and Atmel. Aspects also considered were that the 32-bit ARM featured Thumb and Thumb 2 Instructions sets which are known for using less storage. Thumb is for 16-bit for ARM32 processors exclusively, however, they are also known for having less functionality as a result. Thumb 2 however, not variates in length, but also has the ability to execute in both 16 and 32 bit size. ARM7 and ARM32 feature Thumb mode. Thumb 2 mode however, is only exclusive to ARM Cortex. For the purposes of the team's project, the team decided that anywhere from ARM Cortex M4 to ARM7 would suffice the project if not less since the performance speed having a higher priority in terms of performance, favoring ARM Cortex microcontrollers, as there are so many similar projects using the same architecture. Additionally, ARM 7 microcontrollers require to be initiated by using assembly code. However, the team did not want to use a microcontroller that couldn't previously get their hands on for test purposes and instead wanted to utilize microcontrollers that are

packaged on an experiment board so that the team could familiarize with it during the prototype phase. The first candidate for our microcontroller utilizing ARM architecture is the Texas Instruments TM4C123GH6PM which is based on the ARM Cortex M4F architecture given by its low cost and many reasons listed above. Our second candidate, also being an ARM based microcontroller is the SAM3X8E powered by ARM Cortex M3 architecture made by Atmel which is very popular for enthusiasts and home-brewers alike. For ARM7 we have a third candidate which is the AT91SAM7S512, also made by Atmel. Our fourth and last choice involves the very popular and easy to use AVR microarchitecture, also made by Atmel: The ATmega2560.

Table xxx(*Tiva™ TM4C123GH6PM Microcontroller*): The TM4C123GH6PM Features

Feature	Description
Performance	
Core	ARM Cortex-M4F processor core
Performance	80-MHz operation; 100 DMIPS performance
Flash	256 KB single-cycle Flash memory
System SRAM	32 KB single-cycle SRAM
EEPROM	2KB of EEPROM
Internal ROM	Internal ROM loaded with TivaWare™ for C Series software
Security	
Communication Interfaces	
Universal Asynchronous Receivers/Transmitter (UART)	Eight UARTs
Synchronous Serial Interface (SSI)	Four SSI modules
Inter-Integrated Circuit (I ² C)	Four I ² C modules with four transmission speeds including high-speed mode
Controller Area Network (CAN)	Two CAN 2.0 A/B controllers
Universal Serial Bus (USB)	USB 2.0 OTG/Host/Device
System Integration	
Micro Direct Memory Access (μDMA)	ARM® PrimeCell® 32-channel configurable μDMA controller
General-Purpose Timer (GPTM)	Six 16/32-bit GPTM blocks and six 32/64-bit Wide GPTM blocks
Watchdog Timer (WDT)	Two watchdog timers
Hibernation Module (HIB)	Low-power battery-backed Hibernation module
General-Purpose Input/Output (GPIO)	Six physical GPIO blocks
Advanced Motion Control	
Pulse Width Modulator (PWM)	Two PWM modules, each with four PWM generator blocks and a control block, for a total of 16 PWM outputs.
Quadrature Encoder Interface (QEI)	Two QEI modules
Analog Support	
Analog-to-Digital Converter (ADC)	Two 12-bit ADC modules, each with a maximum sample rate of one million samples/second
Analog Comparator Controller	Two independent integrated analog comparators
Digital Comparator	16 digital comparators
JTAG and Serial Wire Debug (SWD)	One JTAG module with integrated ARM SWD
Package Information	
Package	64-pin LQFP
Operating Range (Ambient)	Industrial (-40°C to 85°C) temperature range Extended (-40°C to 105°C) temperature range

Table xxx (*SAM3X / SAM3A Series Atmel | SMART ARM-based MCU DATASHEET*): The Atmel ATSAM3X8E Features:

1. Features

- Core
 - ARM Cortex-M3 revision 2.0 running at up to 84 MHz
 - Memory Protection Unit (MPU)
 - Thumb®-2 instruction set
 - 24-bit SysTick Counter
 - Nested Vector Interrupt Controller
- Memories
 - 256 to 512 Kbytes embedded Flash, 128-bit wide access, memory accelerator, dual bank
 - 32 to 100 Kbytes embedded SRAM with dual banks
 - 16 Kbytes ROM with embedded bootloader routines (UART, USB) and IAP routines
 - Static Memory Controller (SMC): SRAM, NOR, NAND support. NFC with 4 Kbyte RAM buffer and ECC
- System
 - Embedded voltage regulator for single supply operation
 - Power-on-Reset (POR), Brown-out Detector (BOD) and Watchdog for safe reset
 - Quartz or ceramic resonator oscillators: 3 to 20 MHz main and optional low power 32.768 kHz for RTC or device clock
 - High precision 8/12 MHz factory trimmed internal RC oscillator with 4 MHz default frequency for fast device startup
 - Slow Clock Internal RC oscillator as permanent clock for device clock in low-power mode
 - One PLL for device clock and one dedicated PLL for USB 2.0 High Speed Mini Host/Device
 - Temperature Sensor
 - Up to 17 peripheral DMA (PDC) channels and 6-channel central DMA plus dedicated DMA for High-Speed USB Mini Host/Device and Ethernet MAC
- Low-power Modes
 - Sleep, Wait and Backup modes, down to 2.5 µA in Backup mode with RTC, RTT, and GPBR
- Peripherals
 - USB 2.0 Device/Mini Host: 480 Mbps, 4 Kbyte FIFO, up to 10 bidirectional Endpoints, dedicated DMA
 - Up to 4 USARTs (ISO7816, IrDA®, Flow Control, SPI, Manchester and LIN support) and one UART
 - 2 TWI (I2C compatible), up to 6 SPIs, 1 SSC (I2S), 1 HSMCI (SDIO/SD/MMC) with up to 2 slots
 - 9-channel 32-bit Timer Counter (TC) for capture, compare and PWM mode, Quadrature Decoder Logic and 2-bit Gray Up/Down Counter for Stepper Motor
 - Up to 8-channel 16-bit PWM (PWMC) with Complementary Output, Fault Input, 12-bit Dead Time Generator Counter for Motor Control
 - 32-bit low-power Real-time Timer (RTT) and low-power Real-time Clock (RTC) with calendar and alarm features
 - 256-bit General Purpose Backup Registers (GPBR)
 - 16-channel 12-bit 1 msp/s ADC with differential input mode and programmable gain stage
 - 2-channel 12-bit 1 msp/s DAC
 - Ethernet MAC 10/100 (EMAC) with dedicated DMA
 - 2 CAN Controllers with 8 Mailboxes
 - True Random Number Generator (TRNG)
 - Register Write Protection
- I/O
 - Up to 103 I/O lines with external interrupt capability (edge or level sensitivity), debouncing, glitch filtering and on-die Series Resistor Termination
 - Up to six 32-bit Parallel Input/Outputs (PIO)

Table (AT91SAM ARM-based Flash MCU SAM7S512 SAM7S256 SAM7S128 SAM7S64 SAM7S321 SAM7S32 SAM7S161 SAM7S16): The Atmel AT91SAM7S512 Features:

Features

- **Incorporates the ARM7TDMI[®] ARM[®] Thumb[®] Processor**
 - High-performance 32-bit RISC Architecture
 - High-density 16-bit Instruction Set
 - Leader in MIPS/Watt
 - EmbeddedICE[™] In-circuit Emulation, Debug Communication Channel Support
- **Internal High-speed Flash**
 - 512 Kbytes (SAM7S512) Organized in Two Contiguous Banks of 1024 Pages of 256 Bytes (Dual Plane)
 - 256 Kbytes (SAM7S256) Organized in 1024 Pages of 256 Bytes (Single Plane)
 - 128 Kbytes (SAM7S128) Organized in 512 Pages of 256 Bytes (Single Plane)
 - 64 Kbytes (SAM7S64) Organized in 512 Pages of 128 Bytes (Single Plane)
 - 32 Kbytes (SAM7S321/32) Organized in 256 Pages of 128 Bytes (Single Plane)
 - 16 Kbytes (SAM7S161/16) Organized in 256 Pages of 64 Bytes (Single Plane)
 - Single Cycle Access at Up to 30 MHz in Worst Case Conditions
 - Prefetch Buffer Optimizing Thumb Instruction Execution at Maximum Speed
 - Page Programming Time: 6 ms, Including Page Auto-erase, Full Erase Time: 15 ms
 - 10,000 Write Cycles, 10-year Data Retention Capability, Sector Lock Capabilities, Flash Security Bit
 - Fast Flash Programming Interface for High Volume Production
- **Internal High-speed SRAM, Single-cycle Access at Maximum Speed**
 - 64 Kbytes (SAM7S512/256)
 - 32 Kbytes (SAM7S128)
 - 16 Kbytes (SAM7S64)
 - 8 Kbytes (SAM7S321/32)
 - 4 Kbytes (SAM7S161/16)
- **Memory Controller (MC)**
 - Embedded Flash Controller, Abort Status and Misalignment Detection
- **Reset Controller (RSTC)**
 - Based on Power-on Reset and Low-power Factory-calibrated Brown-out Detector
 - Provides External Reset Signal Shaping and Reset Source Status
- **Clock Generator (CKGR)**
 - Low-power RC Oscillator, 3 to 20 MHz On-chip Oscillator and one PLL
- **Power Management Controller (PMC)**
 - Software Power Optimization Capabilities, Including Slow Clock Mode (Down to 500 Hz) and Idle Mode
 - Three Programmable External Clock Signals
- **Advanced Interrupt Controller (AIC)**
 - Individually Maskable, Eight-level Priority, Vectored Interrupt Sources
 - Two (SAM7S512/256/128/64/321/161) or One (SAM7S32/16) External Interrupt Source(s) and One Fast Interrupt Source, Spurious Interrupt Protected

Table) (Atmel ATmega640V-1280V -1281V-2560V-2561V 8-bit Atmel Microcontroller with 16/ 32/64KB In-System Programmable Flash SUMMARY):
The Atmel ATmega2560 Features:

Features

- High Performance, Low Power Atmel® AVR® 8-Bit Microcontroller
- Advanced RISC Architecture
 - 135 Powerful Instructions – Most Single Clock Cycle Execution
 - 32 x 8 General Purpose Working Registers
 - Fully Static Operation
 - Up to 16 MIPS Throughput at 16MHz
 - On-Chip 2-cycle Multiplier
- High Endurance Non-volatile Memory Segments
 - 64K/128K/256KBytes of In-System Self-Programmable Flash
 - 4Kbytes EEPROM
 - 8Kbytes Internal SRAM
 - Write/Erase Cycles:10,000 Flash/100,000 EEPROM
 - Data retention: 20 years at 85°C/ 100 years at 25°C
 - Optional Boot Code Section with Independent Lock Bits
 - In-System Programming by On-chip Boot Program
 - True Read-While-Write Operation
 - Programming Lock for Software Security
 - Endurance: Up to 64Kbytes Optional External Memory Space
- Atmel® QTouch® library support
 - Capacitive touch buttons, sliders and wheels
 - QTouch and QMatrix acquisition
 - Up to 64 sense channels
- JTAG (IEEE® std. 1149.1 compliant) Interface
 - Boundary-scan Capabilities According to the JTAG Standard
 - Extensive On-chip Debug Support
 - Programming of Flash, EEPROM, Fuses, and Lock Bits through the JTAG Interface
- Peripheral Features
 - Two 8-bit Timer/Counters with Separate Prescaler and Compare Mode
 - Four 16-bit Timer/Counter with Separate Prescaler, Compare- and Capture Mode
 - Real Time Counter with Separate Oscillator
 - Four 8-bit PWM Channels
 - Six/Twelve PWM Channels with Programmable Resolution from 2 to 16 Bits (ATmega1281/2561, ATmega640/1280/2560)
 - Output Compare Modulator
 - 8/16-channel, 10-bit ADC (ATmega1281/2561, ATmega640/1280/2560)
 - Two/Four Programmable Serial USART (ATmega1281/2561, ATmega640/1280/2560)
 - Master/Slave SPI Serial Interface
 - Byte Oriented 2-wire Serial Interface
 - Programmable Watchdog Timer with Separate On-chip Oscillator
 - On-chip Analog Comparator
 - Interrupt and Wake-up on Pin Change
- Special Microcontroller Features
 - Power-on Reset and Programmable Brown-out Detection
 - Internal Calibrated Oscillator
 - External and Internal Interrupt Sources
 - Six Sleep Modes: Idle, ADC Noise Reduction, Power-save, Power-down, Standby, and Extended Standby
- I/O and Packages
 - 54/86 Programmable I/O Lines (ATmega1281/2561, ATmega640/1280/2560)
 - 64-pad QFN/MLF, 64-lead TQFP (ATmega1281/2561)
 - 100-lead TQFP, 100-ball CBGA (ATmega640/1280/2560)
 - RoHS/Fully Green
- Temperature Range:
 - -40°C to 85°C Industrial
- Ultra-Low Power Consumption
 - Active Mode: 1MHz, 1.8V: 500µA
 - Power-down Mode: 0.1µA at 1.8V
- Speed Grade:
 - ATmega640V/ATmega1280V/ATmega1281V:
 - 0 - 4MHz @ 1.8V - 5.5V, 0 - 8MHz @ 2.7V - 5.5V
 - ATmega2560V/ATmega2561V:
 - 0 - 2MHz @ 1.8V - 5.5V, 0 - 8MHz @ 2.7V - 5.5V
 - ATmega640/ATmega1280/ATmega1281:
 - 0 - 8MHz @ 2.7V - 5.5V, 0 - 16MHz @ 4.5V - 5.5V
 - ATmega2560/ATmega2561:
 - 0 - 16MHz @ 4.5V - 5.5V

Manufacturer	Model	Architecture	Memory kB	Clock	I/O Pins
Texas Instruments	TM4C123GH6PM	ARM Cortex M4	256 kB	80 Mhz	~100
Atmel	SAM3X8E	ARM Cortex M3	512 kB	84 Mhz	103
Atmel	AT91SAM7S512	ARM7	512 kB	64 Mhz	55
Atmel	ATmega2560	AVR	256 kB	16 Mhz	100

Table xxx: Microcontroller Candidates

The programming interface is also an aspect that requires research. AVR Microcontrollers were really attractive for the team as they are easy to program since many libraries are as standard as C. Additionally, there amount of open source codes available online makes much easier for the team to learn how to program with the board. Another positive aspect of choosing AVR, is that is fully supported by the Arduino programming interface which allows easy programming. ARM microcontrollers on the other hand, require a little extra work to start. This however, has changed significantly in recent years as developers has adopted the ARM platform thus making it popular and more accessible. Especially if the team chooses the TM4C123GH6PM which is fully supported by Code Composer studio, a tool that's given by the university, or another excellent tool which is Energia that is completely free and allows easy access based on the easiness of AVR IDE. If the AVR route is taken, however, the team has the option of the Arduino's own IDE with the SAM3X8E ARM option as well as the ATmega2560 AVR microcontroller.

Additionally, the team wanted a microcontroller that would be available in a popular experiment board as it would greatly help understand the microcontroller as well as allow the team to work on the table before the creation of a printed circuit board that has all of the components attached to it. Experiment board allow the team to test initial software, test the RGB LED array, or at least a smaller version of it, develop the Bluetooth aspect of our project and potentially write the majority of the code for the final board with the final microcontroller. The team has many available options such as a Raspberry Pi or the Beagle Board. However, these boards far exceed any single category as well as include features that the project doesn't require such as GPU or HDMI output. The valuable aspect of many these experiment boards is that the community support is very notable. The first candidate was the Arduino Mega powered by the ATmega2560, but after some testing the team detected that the clock frequency of the ATmega2560 could lack and hamper the performance of the project. Nonetheless, the ATmega2560 could be a good prototype board for the initial phase of the project but there's a feature that the team did not like which is that the operating voltage, being 3.3v could interfere with the other subsystems and would require some resistance compensation in order to make these subsystems work. Additionally, the price of the Arduino Mega is quite high when compared to the other experiment board

candidates. The case is the same with the Arduino Due which is powered by the Atmel SAM3X8E microcontroller.

Microcontroller and Experiment Board Choice

Finally, the team reached a consensus and decided on the microcontroller that would best suit the needs of the project. That microcontroller would be TM4C123GH6PM from Texas Instruments. The reason why the team chose that microcontroller is because it includes the latest, as of the making of the project, ARM architecture available at the most affordable price. Additionally, since the microcontroller is included in the TIVA C Experiment Board, also from Texas Instruments there is a lot of official support as well as the community. Additionally the price of the TIVA C experiment board is lowest among all of the candidates. Additionally, the fact that the TIVA C is fully supported by Energia which is a free IDE that borrows libraries from the Arduino IDE environment gives it the best of both worlds.

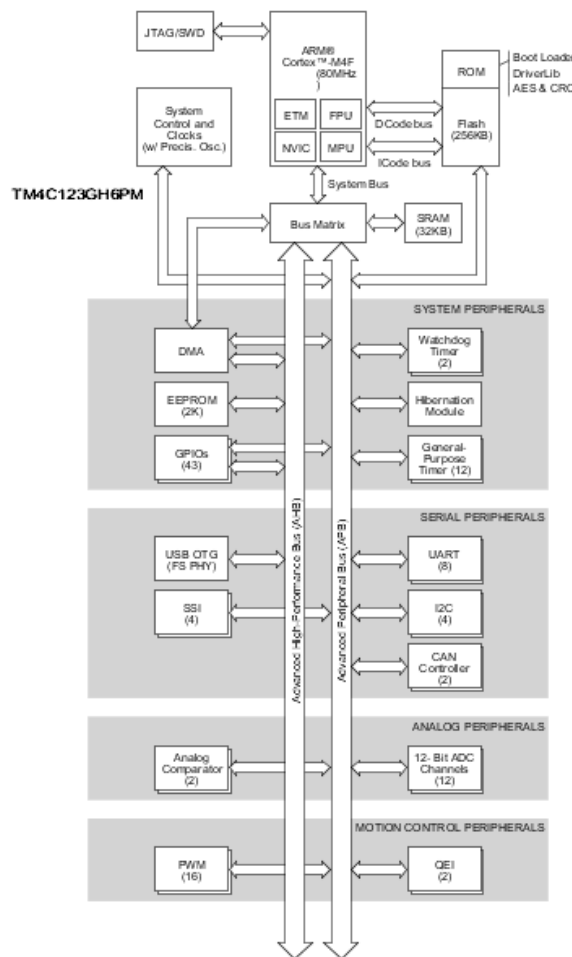

Figure x.xx: TM4C123GH6PM Functional Diagram
Printed with Permission, Courtesy of Texas Instruments

3.3.2 LEDs

As our project is specifically meant to involve an array of LEDs that will allow us to display patterns on our table surface, it is necessary for us to research the different types that we can choose from. First, it is important to understand the technology behind LEDs. LED stands for “light emitting diode” and this technology specifically comes with the advantage that they don’t have a filament that burns out the way incandescent bulbs do (Harris). They are simple to install, durable, efficient, and will fit the purposes of illuminating the surface of our table much better than if we were to use small light-bulbs instead. This way, there will be little need to replace the lights on our table and even if we need to, they can be removed easily.

Single-Color LEDs

This type of LED is built by using a single diode that projects light into its design, usually with either a Red, Blue, or Green color. This is encased within a lens to magnify the effect, and if our project were to make use of this specific type of LED, we would need to use at least 3 in each pixel on our table to get them to project different colors on the surface. LEDs are cheap enough that we could still obtain the necessary amount, even if we would need to get three of them for each pixel, but programming all of them to work together would mean extra work and in the end the color they would produce might not be to our liking as designs based around the use of 3 independent LEDs can have trouble with their resolution. Given the fact that we would need to purchase more of them and the potential drawbacks they would have on our design, we will likely be making use of one of the other options at our disposal, which typically have three light-producing diodes together within a single lens instead of just one. Such LEDs require slightly more programming to operate than a single-color LEDs, but would overall be more efficient to use.

Round RGB LEDs

This type of LED is distinguished by the lens used to modify the effect of the light-producing diode. A truly rounded LED lens “can provide increased efficacy, better uniformity, and superior light quality in many applications” (DeMilo). One of the main reasons that this type of LED is considered efficient, however, is because of the fact that it has been designed to allow light to be emitted from all sides, rather than just one general direction. Since the amount of light produced is the same regardless of an LED’s shape, not using a round LED is technically inefficient. A square LED would end up losing light within its corners rather than projecting it properly, for example. Unfortunately, we don’t have a means planned to account for a round LED to be used effectively in our design. Even though it would technically be projecting more of the light it can produce, we would not have a means of directing the extra light where we wanted it to go. Simply put, we only want light shining towards the surface of the table, and don’t have any real need

for it to be directed elsewhere. As such, we may not use a round LED in our design unless the other options prove less effective my comparison.

Square RGB LEDs

These LEDs are considered more common and adequate for purposes of basic lighting. They are reliable enough, but not as efficient as round LEDs, nor are the able to provide the same level of resolution. Using this type of LED would server little other purpose than to limit the abilities of our design in for no other purpose than that we can. Since this specifically is an “RGB” LED, it is more advantageous for us to make use of it than an ordinary, single-color LED, but beyond this there are few reasons to use this type. It isn’t too cost-effective to use a square LED over any other type, so unless there are blatantly obvious reasons for us not to make use of the other options, we will likely not use this type since we have better options to choose from.

Multi Flashing LEDs

These are a particularly unique type of LED that is capable of an oscillating signal. By using an oscillating signal it is able to make the LED flash regularly and can even act as a kind of switch on the circuit that can activate and deactivate other sections of circuitry. While this is certainly a very useful function in certain situations, it has no serious bearing on our project design and would be unnecessary to include. The LEDs in our design have the specific need to respond to signal input and nothing more. As such, it we will not be using this type of LED as its extra abilities do not provide any benefit and could potentially be a hindrance to work around.

Design choice

After careful consideration of the choices we have, we have decided to make use of Round RGB LEDs in our design. They will provide superior resolution to that of single-color LEDs when attempting to create different color patterns on the surface of the table, as well as enable our design with more efficiency because of their design. Single-color LEDs are less efficient to build into our design and will have inferior resolution, Square LEDs don’t project light as efficiently, and Multi-flashing LEDs have unnecessary extra functions. Therefore, our design will make use of round LEDS instead.

3.3.3 LED Controller

The LED controller was an additional aspect that is very much needed for our project. The design problem begins with the fact that no of the microcontrollers research, and to be more precise, our candidate microcontroller does not have enough pins to drive the entire RGB LED array as the array is composed of over 250 RGB LEDs. As far as the team's knowledge goes, there isn't a single microcontroller with enough pins to drive over 250 RGB LEDs, and even such microcontroller existed, there could be a potential current issue where the microcontroller would not have the required power to drive all of the LEDs. The team could use shift registers to solve this engineering problem but they also have the same problem as they do not have the capability to drive the required current. Therefore the team researched and come with the conclusion that the most adequate solution would be an LED Drive as it gives the ability to extend the number of outputs without sacrificing many input and output pins of the microcontroller and providing the RGB LEDs with sufficient current for them to light up at an adequate brightness level.

TLC5940 LED Driver with PWM

The TLC5940 from Texas Instruments is a solid choice for the team as research showed that it was the most popular amongst every project. This didn't stop the team, however, to find any other choices. This IC allows up to 16 channel outputs in PWM to control the brightness of each one of those channels and it has a built EEPROM that stores the memory of the last state of the output. It also has current sink with dot correction which is really helpful when dealing with many LEDs because some of them may be brighter than others given by the imperfection of them. Dot correction will adjust the brightness of every single LED. The way the TLC5940 Works is that the memory input works serially. This method significantly reduces the amount of I/O. One thing to keep in mind about this IC is that it does not provide current directly. Each one of the single LEDs connected have their own current source and the IC acts as a switch for each individual LED that have their current provided to their anodes.

This the team's most logical choice as this IC has the ability to supply the current for all the LEDs as well as giving the ability to control each individual LED attached to it. One thing that is to be noted is that there are 16 channels available but each RGB LED utilizes 3 channels giving you a theoretical maximum of 5 RGB LEDs per each TLC5940, another important aspect is that these ICs can be connected in series. Some pins need to be connected in parallel and then serial out from IC "A" to the serial-in from IC "B" and so forth.

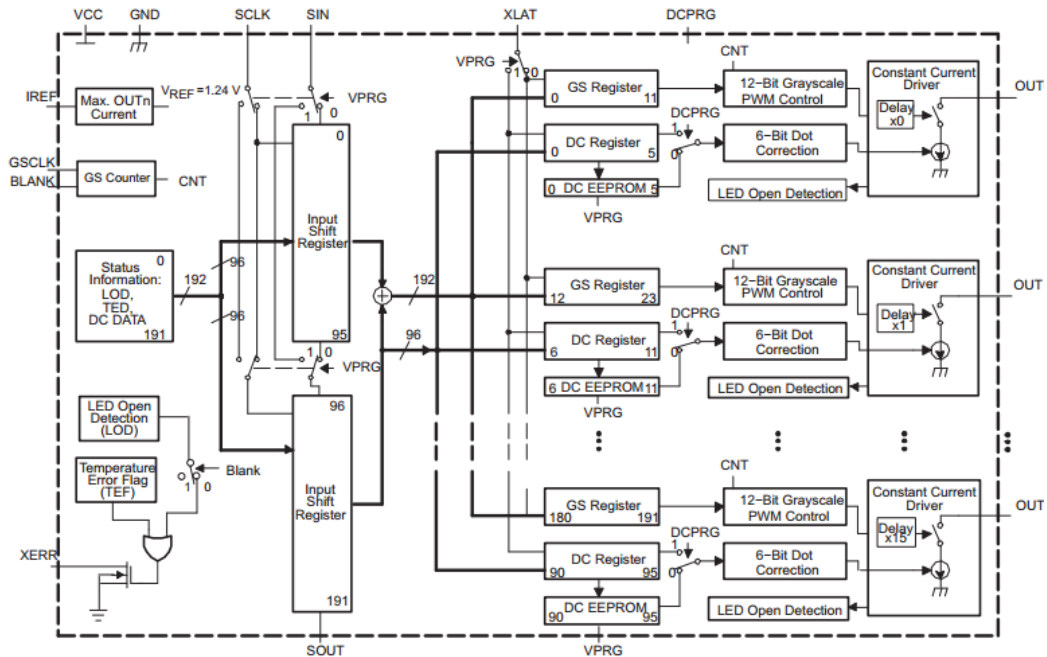

Figure x.xx: TLC5940 Block Diagram
 Printed with Permission, Courtesy of Texas Instruments

TLC 5940 Detailed features:

- 16 Channels
- 12 bit (4096 steps) Grayscale PWM Control
- 6-Bit dot correction storable in integrated EEPROM
- Drive capability 0 mA to 60 mA when Vcc is less than 3.6V
- Drive capability 0 mA to 120mA when Vcc is greater than 3.6 V
- Serial Data Interface
- Vcc acceptable from 3V to 5.5V
- 30Mhz Data Transfer Rate
- CMOS Level I/O
- Controlled In-Rush Current
- LED Power Supply Voltage up to 17 V

A6282 LED Driver

The A6282 from Allegro is another fine choice for the team as a LED driver. However, this option lacks PWM which would affect the brightness of the LEDs attached to the IC marginally. Besides the lack of PWM the A6282 is very comparable to the TLC5940 from Texas Instruments. Both offering up to 16 constant current outputs. The A6282 works with input shift register with data latches. Another aspect that is to be noted is that the A6282 also lacks the dot correction. This implies further testing of the RGB LEDs for the team since due to the imperfection of the LEDs one could be brighter than the others thus making the project somewhat unappealing. Another negative aspect during the research was that Allegro is no longer supporting this line, thus, making finding community codes or tutorials on operating this IC a bit cumbersome. However, the price of this IC is significantly lower than the TLC 5940 which would return in some savings on the creation of this project since the team will purchase a significant amount of these ICs.

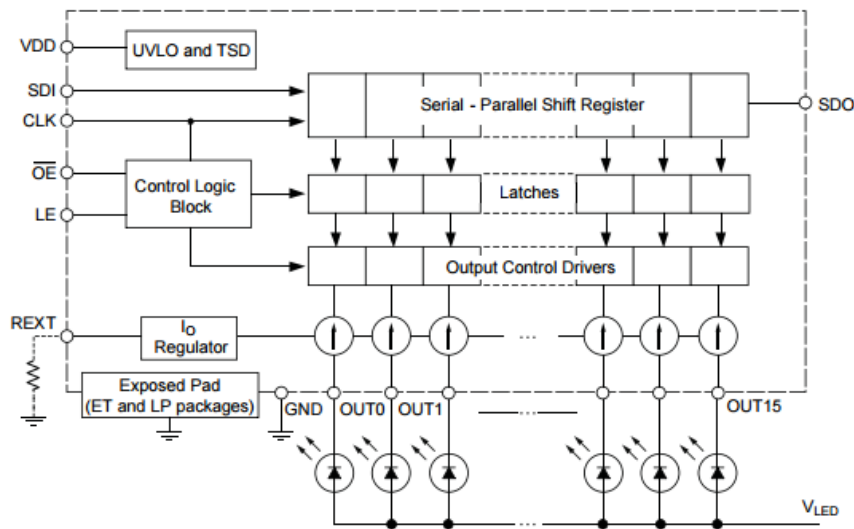

Figure x.xx: A6282 Block Diagram
Printed with Permission, Courtesy of Allegro.

A6282 Detailed features:

- 16 Constant-current outputs, up to 50 mA each
- LED Output voltage up to 12 V
- 3.0 to 5.5 V logic supply range
- Schmitt trigger inputs for improved noise immunity
- Power-On Reset (POR), all register bits = 0
- Low-power CMOS logic and latches
- High data input rate: 30 Mhz

- Output current accuracy: between channels $<\pm 3\%$ and between ICs $\pm 7\%$, over the full operating temperature range
- Interval UVLO and thermal shutdown (TSD) circuitry

LED Driver Decision

For the team the choice was very clear. The Texas Instruments TLC5940 would give tremendous benefits for our project. The latter choice although being more economic as an individual part, would require the team to purchase additional ICs to add the PWM functionality and every other feature that the Allegro IC lacks. Additionally, the amount of documentation and projects involving the TLC5940 is so vast that the team could find a substantial amount of useful information to become more acquainted with the TLC 5940.

3.3.4 Impact Sensors

Another relevant component required for the creation of the project is the choice of the impact sensors or otherwise sensors that would detect motion or force applied to the table. For this particular feature the team spent a significant amount of time as they were in search of the most efficient way of achieving the previously set objectives.

The sensors had to meet the following criteria:

- Ability to detect a ping pong ball as it bounces in the field.
- Ability to detect a cup being removed.
- Detection must be real-time and accurate.
- Must not be intrusive for the table.

Microsoft Kinect

The team proposed the idea of having the Kinect as a single module that would identify the cups and ping pong balls bouncing through the field. The Kinect would be placed on a ceiling or high position facing down completely capturing the table. Since the Microsoft Kinect has the ability to detect the distance of objects and all the different sensors on its disposal it could solve the objectives of the cup detection and ball bounce. The cup detection could be resolved with some sort of template matching utilizing the color of the cups as template or even a picture of the cup from an upwards field of view. In regards of the ball detection, some programming logic could determine that if any object reaches a certain distance then it could register as a ball bounce. The Kinect is relatively easy platform to program for as it has an API and another reason why is considered is because one of the members of the team already has a Kinect in their possession. The Kinect however, has some negatives as it has been proven to be often unresponsive as the purpose of the sensors are not fully designed for the project's usage.

Additionally, the positioning of the Kinect could potentially hinder the design of the table making it more complicated. Another issue is that the Kinect could potentially require to have optimal lighting conditions in order for it to function correctly as well as having a limited framerate that could not meet the real-time or otherwise snappy requirements.

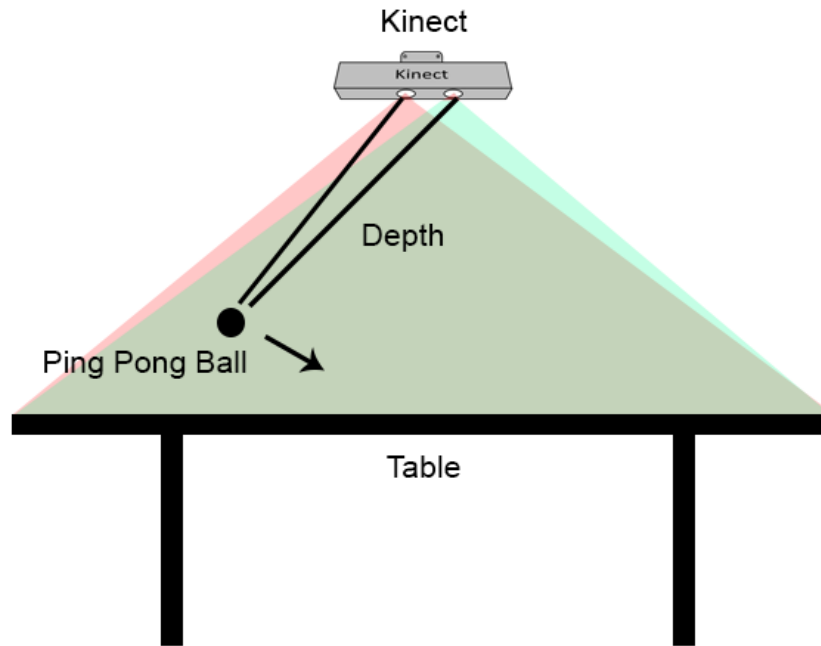

Figure x.xx: Kinect Application to Project Diagram

TE Connectivity Measurement Specialties 1005939-1 Vibration Sensor

The second option would involve a vibration sensor, or more specifically, a cantilever-beam accelerometer. In the team's case, the Measurements Specialties 1005939-1. In any case, any vibration sensor with comparable specifications. The idea behind the implementation of this type of sensor would involve having an array of these vibration sensors in such a way that they would detect the vibration of when the ping pong ball hits the main area of the table. The way these sensors often work is by having a mass at the end of the beam that if placed horizontally, could detect impulsive vibration that generates a frequency that is transferred as a charge or voltage output that can be sensed by the microcontroller. These types of sensors are used in many fields where vibration needs to be sensed to alert an event such as anti-theft devices, tamper detections, vehicle motor sensor, etc. The sensor would require to be strategically placed in order to register the vibration of the ball. The amount of channels required are only two thus making it a very attractive choice for the project. The microcontroller would most likely interpret them as an auto-filled large array that would have ever-changing numbers as it would pick up vibrate for many external sources. Therefore, some sort of algorithm would be required that whenever a spike appears on such array, that object with the highest value would correlate to the designated RGB LED that correspond with

that specific sensor. However, after deeper examination it was determined that the impact sensor could not be sensitive enough to detect a ping pong ball. Additionally, the nature of the sensor could be problematic since all of the sensors could activate at any time, it would require some sort of high threshold to activate the aforementioned sensor. Another issue could be presented that since the table is intended for activities such as social gatherings that often include music being played at high volumes and crowds; these external factors could potentially generate vibrations strong enough that could activate the aforementioned sensors beyond the pre-established threshold and could be recognized as a triggered sensor, thus potentially making the sensors not fully responsive and somewhat inaccurate, thus hampering the experience of what the original objective was set. If the team wants to utilize the aforementioned sensor, then it is much recommended that extensive testing must be done before fully investing in a large quantity of the aforementioned sensors.



Figure x.xx: TE Connectivity Measurement Specialties 1005939-1 Vibration Sensor

TCRT5000L IR Infrared Reflective Sensor

The TCRT5000L IR was another discovered solution that could solve our impact sensor problem. Many of the projects previously done that involved an array of LEDs that react to nearby objects were powered by some sort of infrared proximity sensor for either each single LED or a group of LEDs. The infrared proximity sensors would function as an array, the same way as the vibration sensors. The infrared sensors are also digital and variable as the vibration sensors. The values increase or decrease depending on how they are programmed and how close the object is from the sensor. Basically, the way that these sensors work is that they send an infrared signal, invisible to the human eye, the beam shoots in an upwards position and this infrared signal then “bounces” or reflects off the nearby object and an infrared receiver then senses this signal and based on how much it receives it can detect how far the object is. These sensors, in particular, the TCRT5000L are not entirely accurate as they are not meant to detect the distance of an object but to tell how approximate the object is in reference to the sensor. The usage of

these sensor varies in many fields such as robotics. Often, these sensors are used to tell if a robot near collision of an object to avoid an obstacle or a wall. It is quite reliable and the benefit of using this package is that it not only includes the infrared receiver but it also has a built-in infrared emitter in a single package which could potentially reduce the cost of the impact sensor array as well as wiring. One potential negative for the usage of this sensor is that in social gathering, some odd lighting conditions could occur that could trigger the aforementioned sensors making them potentially unreliable. However, as test shows, this seems to be very rare and it does not seem to affect the performance of the aforementioned sensors. Another aspect that needs to be evaluated, which also affects the previous option, is that the microcontroller does not have the required amount of pins for the array as more than 200 of these sensors will be used, therefore, the usage of an integrated circuit that would increase the number of inputs and outputs of our microcontroller, such as shift register or mux is required. Overall, the usage of an infrared proximity sensor could prove useful.



Figure x.xx: TCRT5000L IR Infrared Reflective Sensor

Sharp IS471F Infrared Detector

Another option would be the Sharp IS471F Infrared sensor. It utilizes the same technology as the previous where it detects an infrared signal from an emitter. The benefits of using the Sharp IS471F over the TCRT5000L is that the Sharp sensor is capable operating under any lighting condition as it impervious to external disturbing lights, which could benefit the performance of the impact sensor array as the table needs to be able to fully operate under any lighting condition as many of the aforementioned social gatherings do not have the best lighting conditions. One negative, however is that the package does not include an infrared emitter thus making this solution marginally more costly than the previous. Another positive, however, is that the IS471 infrared detector includes a built in pulse driver, or in other words, the required components to attach an LED emitter with pins readily available to create a somewhat similar proximity sensor setup as the

previously mentioned option, thus, somewhat compensating for the lack of an emitter by making the wiring slightly more simple.



Figure x.xx: Sharp IS471F Infrared Detector

Impact Sensor Decision

The impact sensor choice came in two flavors, the TCRT5000L IR Infrared Reflective Sensor, or the Sharp IS471F Infrared Detector. Neither option could hamper the performance nor requirements of the project as both have proven to be the most correct solution to the problem at hand. However, only one choice could be taken and after evaluating the economic aspects, the TCRT5000L was the logical sensor to utilize in the project. This could change, however, given after further hands-on test are made to verify that the TCRT5000L is capable of fully performance on most lighting conditions. If it is determined that the TCRT5000L is not capable of performing on the aforementioned conditions then it would be replaced by the more superior and expensive Sharp IS471F.

3.3.6 Shift Registers

As briefly mentioned on the previous section, another integrated circuit, or IC, is required to further increase the amount of inputs of the selected microcontroller as this one does not possess the required amount of input and output pins to have an attached a Bluetooth module, the RGB LED array and the Impact Sensor array. As an LED Driver was chosen, as Shift Register is also required to house the large number of sensors required to satisfy the Impact Sensor array objectives. The criteria for this selection is not as relevant as the shift register does not require to have any especial features other than it being low cost as the team wants to keep the selection of the components as low cost as possible since over one thousand components will be purchased upon the creation of this project.

3.3.7 Ball Cleaner

When playing beer pong the ping pong balls used are known to get dirty. When playing beer pong the last thing you want to happen is have dirt in your beer and have to drink dirty beer. Some are known to just have an extra cup with water to wash this ball off. Thus the dirt ends up going from the ball to the cup of water. Thus the next time the ball is washed it is being washed in a cup of dirty water this time. This can be seemingly annoying having to fill the cup with clean water to keep the ball clean. Thus a ball washer is implemented and keeps the ball clean without having to replace or clean anything yourself. A ball washer can consist of several different processes ranging from water pump systems, fan system, to vacuum systems. The main two seem to be water pump systems and fan systems.

Types of Washer Systems

Water Pump

A water pump consists of a pump that pushes water through tubing or system out of water source and out to a desired area. In this case with a movable table the pump would likely pump water from a reservoir out through tubing and back into the same reservoir. To eliminate the dirt contamination we would install or purchase a water pump with a filtration system to collect the unwanted dirt collected from washing the ping pong ball. Water pumps are better to have since the water cleans the ball more effectively than air would but they are more costly and can produce spillage or leaks which is hazardous to electrical components near it. There are pumps that can be connected to a water source like a refrigerator would and there are pumps that are placed inside a source of water like a fountain or pump used to empty a pond. To make it as transportable as possible we would want to implement a pump that does not hook up to a source of water but can be put inside a water source we can obtain from anywhere such as a faucet or water bottle. These are called submersible pumps and can be as simple as putting in a bucket of water. In this case we would want a space under the table capable of containing a sufficient amount of water for the pump to be completely submerged. With three holes of access allowed; the pump can supply water to the piping built for the ball to be transported; an access for the power cable to supply power to the pump; and an access for the water to return to the reservoir. Since we don't need a large amount of water being pumped we don't need an expensive or powerful pump. Making the table as transportable as possible we aim for the smallest pump possible.

Air Fan

Air Fan systems consist of a device that pushes air through a system to move or carry an object to the desired point. There are vacuum systems and also fan systems that can be used to move an object using air. A vacuum system is much more complex and unnecessary in this case so we focus on a fan system. A fan is used to push the ping pong ball through tubing from one end of the table to the other end. Air pumps are much easier to use and can't ruin any electrical components but do not clean quite as thoroughly as water would. The typical types of air fans used for this type of project are usually just old computer fans or small motor fans. Electric motors are electrical components that turn electrical energy into motion or mechanical energy. These components are found in applications such as fans, pumps, power tools, and thousands of other appliances. In this case we want to look at motors capable of powering a fan. Computer fans come in various sizes, speeds, and prices and aren't as easy to customize as motors thus we will focus on electric motors. The first type of motor is the stepper motor which is generally used when precise rotations are calculated. A stepper motor is a brushless DC electric motor and has certain number of steps that equals a full rotation. The next type of motor is a gear motor that can supply more torque at lower RPM. Gear motors are used in various jobs such as lifts, medical tables, and robotics. There are different types of gear motors also such as brushless, parallel and right angle gear motors. When looking at motors we want a motor that can push the ping pong ball through tubing with enough force to get to the other end and not fall back into the tubing. Thus we need a fan with high torque to push the ball strong enough out the end of the tubing. Torque is the force the motor applies to the fan to make it turn. Thus the more torque the faster the fan can spin and the more weight it can turn also. We also need a high RPM to keep the ball stable and prevent it from falling back into the tubing. RPM (rotations per minute) is the measure of the number of rotations around a fixed point in a minute. RPM is not an approved unit by the SI (International System of Units) thus it is calculated in radians per second or Hertz. Motor voltages range from as low as 1.5 volts to over 12 volts but the more voltage and current the stronger or faster the fan can push. Since we are pushing an object and not just cooling it we need a stronger more powerful fan to push a wet or dry ping pong ball approximately weighing around 2.7 grams. The more powerful the fan the better, the voltage and current can be modified to adjust the speed of the fan. If the fan pushes the ball too hard we can decrease the power to the fan and slow the fan down. We cannot exceed the motors capabilities or maximum load thus if the fan cannot push the ball enough a new motor is needed.

Piping System

To move the ping pong balls, water, and air flow from one area to another there are countless types, shapes, and tools to direct it. The easiest and most simple way to direct these to a desired location is to use piping and tubing. Piping comes in various sizes but we want a size just bigger than a ping pong ball. If the piping is too small then the ball will not fit or travel. If the piping is too big we waste the force being exerted by the fan. The first type of piping is copper piping which is soft and flexible and can bend around obstacles. It is typically heavier and used for plumbing mainly like refrigerators, washers, and air conditioner units. The downside to using copper piping is that it is much harder to bend or solder copper piping than it is to glue other types of piping and is more expensive too. The next type of piping is PVC piping. PVC piping is the most commonly known type of piping. It is used in various needs such as cold water movement, irrigation, draining systems, and outdoor water systems. PVC is made in various sizes and shapes ranging from a half inch to two inches in diameter. PVC uses special solvent cement that reacts to the piping and adheres to its fitting like glue. A special primer is also used for PVC piping to clean the surface being cemented to allow the pipe to be fully secure. PVC has many types of connections, valves and fittings that allow almost anything to be done and constructed making it the most reliable and changeable system at a low cost. The only downfall is that it is not generally used for hot water due to melting purposes. The next type of piping is CPVC piping which is basically the same as PVC but has a higher chlorine content making it withstand a wider range of temperatures. This piping is slowly replacing PVC piping inside homes and is able to transport hot water unlike PVC can. This also requires a primer and cement but not normally used for other plastic solvents. There are plenty more types of piping but not that will be used for this design thus we have listed the possible piping we will choose from.

Tubing System

Although most types of tubing are considered flexible especially compare to piping, the flexibility can still vary significantly. PVC and Polyurethane tubing (different than PVC pipe) are considered the most flexible that is made. PVC is less bearable to damage than Polyurethane is and polyurethane can withstand higher pressure also. Polyurethane also has great memory and excellent for coiled tubing. Polypropylene, Polyethylene, FEP, Kynar, and Nylon are harder plastics making them less flexible but still have a good memory. FEP has excellent heat resistance of up to 400 degrees Fahrenheit and is typically used in high purity uses and where chemical resistance is required. Because of their economical value Polypropylene and Polyethylene are used in liquid transfer. Nylon tubing is commonly used for high pressure, heat, and chemical resistant applications. A type of PVC tubing known as Vinyl tubing is mainly used in moving liquids or small amounts of air. These types of tubes are found in household appliances or animal tanks that require air or water. They are extremely flexible and usually clear making them able to see inside for clogs or dirt. Thus making it perfect for a beer pong water pump and filter system. The disadvantages of tubing is that it is usually joined and

connected by clamps or pressure fittings making them more sustainable to leaks or come unconnected.

Microcontroller

A microcontroller uses the same applications as a computer minimized into small module. Many applications can be implemented onto a microcontroller including a CPU, memory, and I/O. Microcontrollers are typically used for smaller applications like programming LED's or small hardware. Microcontrollers that are programmable are designed to be used for embedded applications. Unlike microprocessors that can be found in PCs, microcontrollers are used in automatically controlled devices including power tools, toys, implantable medical devices, office machines, engine control systems, appliances, remote controls and other embedded systems. When looking at microcontrollers we don't need a very advanced one to control just sensors and a motor. The good thing about this is that microcontrollers although they look expensive and complex they really are easy to use and don't cost much at all. When you think of microcontrollers you think of all the choices there are. First you have to decide the microcontroller size, whether you want an 8, 16, or 32 bit microcontrollers. Once the size is determined then you can worry about RAM, flash size, speed, supply voltage, inputs, outputs, and many other specifications. Microcontrollers can have built in USB, Ethernet, and serial ports to make it easier to use. The size of the memory is an important consideration allowing you to not run out of program space. The two types of memory are flash and RAM able to use on microcontrollers. Obviously the larger amount of memory the better but in this design since we are only controlling a motor and IR sensor there won't be a large amount of coding. Microprocessors also have an operating voltage range which allows the connections connected to the microprocessor to be powered. For example, some microprocessors have a 5 Volts outlet or the VCC of the Microcontroller needs power so a higher recommended input is given and is normally higher than the operating voltage. Another key ingredient in picking a microprocessor is the I/O pins. Most microprocessors have digital input/output pins where some of them can be used as PWM (pulse-width modulation) outputs which allows voltage to the outputs. There are several connections that can be used to power the microprocessors too. Typically a computer USB can be used to power the microprocessor and allow it to be coded. Another way which is the way we are using it is to be connected to an AC-DC power supply. This way a computer is not needed and makes transportation much easier. Another important component of the microprocessor is the clock speed. Clock speed is the number of clock cycles it takes to execute each instruction. Thus the faster the clock the faster the microprocessor executes the program. If a microprocessor had a low clock speed then the device could react slowly to being turned on or a button pushed. Hence a computer with a faster clock speed would turn on or open an application faster than a computer with slower clock speed. Normally clock speed is measured in Megahertz but can be as large as Gigahertz sometimes.

Sensors

When looking at sensors there are thousands of different types or kinds. If you look at the table below you can see the different types of sensors that are possible to use and how they are used/work.

Sensor Types	Description	Uses
Photoelectric	Detects distance or presence of an object using a light transmittance.	Security devices, Proximity sensors.
Proximity	Emits an electromagnetic beam of radiation and detects changes in the field.	Parking sensors, touch screens, Improvised Explosive Devices (IEDs), Roller coasters.
Microwave	Emits a continuous wave of microwave radiation and detects an object passing through by shifts in reflected microwaves.	Doppler radar, Radar guns.
Passive Infrared	Detects infrared light emitting off of objects in range of view.	Outdoor lights, motion detectors, burglar alarms.
Magnetic	When an object disrupts the equilibrium of the magnetic fuse it initiates a detonator.	Land mines, depth charge.

Photoelectric would be hard to implement due to lighting of LEDs lighting up room and turning colors. Thus the sensor would have trouble detecting with all the light changing. Proximity sensors are reliable sensors because they detect changes in the radiation which is hard to disrupt without movement of an object through it. Microwave sensors also seem like a reliable component very similar to the infrared sensor. The main problem with microwave sensors is they are much larger and pricier than infrared sensors. Magnetic sensors would be hard to implement because then the balls would somehow have to disrupt the magnetic equilibrium and ping pong balls are not magnetic. We could implement the ping pong ball to spin a magnet when drop that will disrupt the equilibrium but that just adds more parts and more complexity to the design. Most commonly used in everyday devices is the Passive Infrared Sensors. These are seen in everyday occurrences from motion sensor lights on houses to indoor occupancy sensors. Passive infrared sensors are small, low-power, cheap, and easy to apply to circuits thus making

them perfect for this design. They are called passive because they do not emit infrared energy themselves. The hotter something is the more infrared energy they give off but they don't need to be hot to give off infrared energy. The passive infrared sensors pyroelectric sensors due to the heat component it senses. Passive infrared sensors detect the infrared measurements and compare them to normal or previous levels. Passive infrared sensors are made to measure infrared energy emissions usually ranging from 8 to 12 micrometers but can vary on size. They use a tool called a photo detector which receives incoming light and records its level of infrared red energy or wavelength. Sensors can detect a wide range of wavelength so most have built in filters to restrict the detectable range. Most passive infrared sensors also have built in elements that cancel out unwanted vibration or temperature changes.

3.3.8 Power Supply

A power supply unit or PSU is an electronic device that supplies power to another device. From an outlet it receives power and can either transfer, change, or convert the power. The most common power supply used is an AC to DC converter. Most computer or electronic devices used require DC voltage to power them. There are several categories of power supplies which include regulated, unregulated, and adjustable power supplies. A regulated power supply holds a constant output voltage or current. An unregulated power supplies voltage and current that can change according to its load. Adjustable power supplies can be set by mechanical controls or input. The power supply is the first place a surge or spike can occur, so most power supplies are designed to handle any fluctuations. Most power supplies have fuses that will blow instead of damaging the other equipment. A fuse is a low resistance resistor that in a sense sacrifices itself to save the other components. It is much cheaper to replace a power supply than the device it is powering. It is a great idea for equipment to use a UPS or surge protector. A UPS is an electrical device that supplies emergency power to a load when there is an interruption in the input power. A surge protector is an appliance that is typically designed to protect electrical devices by shorting to ground any voltage spikes.

Types of Power Supplies

There are many ways to define a power supply. A power supply can be a regulated or unregulated power supply. It can also either be a linear or switching power supply. These all depend on what the power supply is being used for and the device it is powering. The difference between a regulated and an unregulated power supply is just how it sounds.

Unregulated Power Supply

When we talk about an unregulated power supply, we mean that the voltage or current in the output is not controlled by a regulator. This means the DC output is reliant on the amount of current used by the electrical load the power supply is supplying. The first concept to grab when discussing unregulated DC output is they are designed to produce a maximum current output to the load. The output voltage

will decrease as the output current from the power supply increases to the load. For example, if the unregulated power supply is not connected or supplying no power to any electronic device at the moment, then the output voltage will be greater than its output rating. This happens because the current is lowered because it isn't supplying power. When it is hooked up to an electronic device with the requirements met of the power supply, then the current increases to its normal rate and the voltage decreases to its normal rate. The second concept of unregulated output is to understand that they do not produce a clean output. The closer the output measurements are to the loads requirements, the more pure the DC voltage will be. The noise is a ripple in the AC voltage that is supplied from the outlet and then turned to DC voltage. This can be reduced by adding a capacitor that smooths the ripple. The last concept of the unregulated power supply which also pertains to a regulated power supply also is that the output current should absolutely never exceed the loads maximum current listed on the load. Doing this could result in cause the voltage to drop below its rated value and overload the power supply. Overloading a power supply can lead to damage of the supply if precautions are not taken or even start a fire due to the heating. When selecting or designing an unregulated power supply there are key things to look at. First you want to determine the loads power requirements of current and voltage. Then you want to design or find one that meets the similar requirements as close as possible. Don't forget that the loads maximum current rating should not exceed the maximum current rating of the power supply.

Regulated Power Supply

A regulated power supply is a power supply that converts AC (alternating current) voltage into a constant DC (Direct current). It can also supply a stable current also but is less likely than a constant voltage. Regulated power supplies are less common than unregulated power supplies but mainly due to the cost. The DC voltage output will always stay inside the designed values regardless of the current drawn from the load. There are three parameters that a systems voltage regulation depends on. The first parameter is load regulation. Load regulation is the measure of the capability of maintaining a constant output voltage regardless of the loads size. The next parameter is line regulation. Line regulation is the measure of capability to maintain a constant output voltage regardless of changes in the input voltage or source voltage from an outlet in most cases. The last parameter for a regulated power supply is temperature dependence. Temperature dependence is the capability to also maintain a constant output voltage regardless of changes in temperature of the components in the power supply. When choosing a regulated power supply you also want to check power requirements just like the unregulated power supply. When designing your own regulated power supply you want to design it to power all of your devices or as many as possible.

3.3.9 Smartphone/Computer App

The smartphone application and computer application are important for this project because these applications will be used for the user interface component of the **{insert project name}**. So in order to determine how to implement the user interface of the **{insert project name}**, the project group has to determine certain things about the phone application and the computer application.

3.3.9.1 Smartphone App

The smartphone app is important in that it will be the main component for the user interface. For the smartphone, the project group will have to take into account several things in order to determine which mobile operating system will be best suited to fit the needs of the group. The factors that we will be considering when choosing which smartphone operating system to use, the group will take into account such things as how much it will cost to develop, how many users are currently using smartphones with the desired operating system, and the groups accessibility to develop on the designated operating systems. When it comes to cost, the group is looking for the most cost effective smartphone operating system. Besides cost, the project group is also looking for a platform that has a high amount of users to enable the smartphone app to be used by a good amount of people. The project group wants to use the system that the group can most readily take our current experiences and quickly incorporate it into developing for the desired operating system.

iOS Operating System

To develop on the iOS operating system, the project group will need a Mac computer running OS X 10.9.4 or later. The development of an iOS app will require the need for Xcode integrated development environment (IDE) and the iOS Software development kit (SDK). In order to use the Xcode IDE, the project group will have to obtain it from the App Store for free on the computer running the Mac OS. When downloading the Xcode IDE, the group will also receive access to the iOS SDK is included in the Xcode download. Although the required IDE and SDK are free, due to the fact that the group does not have access to a Mac computer, the group would need to invest in obtaining one if the group choose to make an iOS application.

Another option the group would have to consider would be the amount of users that are currently using the iOS platform. According to IDC, iOS has an 18.3% market share during the first quarter (Q1) period of 2015. This statistic shows that it is the second most abundant mobile operating system on the market. Even while being the second most mobile OS on the market, the iOS is only used on one line of smartphones called the iPhone. So when developing an app for the smartphone,

the group would not have to worry as much about bugs that may appear as the result of developing for different lines of phones.

The last thing that the group will have to consider is to see if they can readily build on the iOS operating system. As of the moment this paper is being written, no one in the group has developed or worked on an iOS application. This means that the group would be unfamiliar with the Xcode IDE as well as the iOS SDK. The programming language used for Xcode is Objective-C programming language which is a program language the project group has no experience working with. However, Objective C is built on top of C programming language and it provides object-oriented capabilities. The project group has experience working with the C programming language and object-oriented programming. With this prior experience, the project group should not have too much of an issue programming with Objective C should the group choose to create an iOS application.

Android Operating System

To develop on the Android operating system, no specific computer operating system is needed. So if the project group wanted to, they can develop on a computer running Windows, Mac OS X, or Linux. If the group were to develop on Windows, the oldest version required to do so is Microsoft Windows 2003. For Android application development on Mac OS X, the group would need a computer running at least Mac OS X 10.8.5 or higher. Should the group decide to work with Linux, a GNOME or KDE desktop that runs GNU C Library (glibc) 2.15 or later is needed to develop an Android application. No matter what operating system is used, the Java Development Kit (JDK) 7 and the Android SDK is needed, but that can be obtained for free. Android has its own IDE ready for anyone to use called Android Studios but the group can choose another IDE such as Eclipse in order to develop the Android application. Both IDEs are free to download. So since the project group has access to computers running versions of Windows that fit the system requirements for Android Application development, the project group would basically spend no money in order to develop our desired application using the Android Operating System.

Just like with Mac iOS, the group has to take into account the population size of the users that are using Android based smartphones. Well according to IDC, the Android operating system has a 78.0% market share for the first quarter period of 2015. This is by far has the largest portion of the market share of any mobile operating system. However, although it is the most widespread mobile OS within the US market, the Android OS, unlike the iOS, consists of many different lines of phones the more well-known ones are the Samsung Galaxy and HTC One brands. So due to the fact that the Android operating system is spread out more between different types of smartphones, if the project group were to develop on the Android platform, the group will need to take into account of bugs and different features that may appear on different smartphone lines as the development of the app takes place.

The group will now have to determine how well their prior experiences will translate to working on the application using the Android operating system. For building the Android application the project group can use Android Studios but they are not limited to only that IDE. Android application bases its development on Java. Besides Android Studios, the Eclipse IDE is also a capable choice when it comes to developing for Android. In order to develop on Eclipse, the free plugin called Android Development Tools (ADT) is needed. While only one in the project group is familiar with Android Studios, everyone else has prior experience working with the Eclipse IDE or has some background when working with Java. Although the project group has limited experience when working with Android Studios, due to the experience with java programming, it should not be too difficult for the group to become more familiar working with the IDE. However since the group the majority of the group is more familiar with working on Eclipse IDE, the group will probably become more acquainted to developing the Android application on it instead. No matter which IDE the project group decides, the group should have no issues to develop the application portion of the project on the Android operating system.

Windows Phone

To develop on the Windows OS for smartphones, known as Windows Phone 10, we need a computer that runs on a Windows version of either Windows 8, Windows 8.1, or Windows 10. Once the computer has the desired Windows operating system, the next software we need to develop a Windows application is the Windows 10 SDK. This SDK includes all the tools the group would need in order to create a Windows Phone application. In this SDK is Microsoft Visual Studios 2015, SDK templates and tools, Windows Phone emulator, and more. The project has access to a Windows operating system that can be used to develop a Windows Phone app and all the software for it can be acquired through the means of free downloads. So the project group can start developing a Windows Phone application for a relatively no money.

The next thing the project group has to take into account are the amount of people that currently has a smartphone that uses the Windows mobile operating system. According to IDC, the Window Phone OS has a market share of 2.7% at the end of the first quarter of 2015. Of the three mobile operating systems that the project group is considering using so far, Windows Phone OS has by far the lowest user support compared to the other two mobile operating systems. This means that the amount of people that have a Windows smartphone is comparatively rare compared to those that have iOS and Android OS smartphones. Although having a much smaller size of the market share, Windows Phone OS is similar to Android's in that they both have multiple different lines of phones that run their OS. So, if the project group decides to develop on the Windows platform, like android, the group might have to be on the lookout of different bugs and different features that the different types of phones may have.

To work on the Windows phone OS, the project group would need to use the programming languages C#, C++, or JavaScript within Microsoft Visual Studios 2015. The project group is relatively familiar with working with these programming

languages. However, the group are not too familiar with working on Microsoft Visual Studios. With the group having some sort of experience with the programming languages, it should not be too hard for the group to get used to working in Microsoft Visual Studios.

Smartphone App Platform Choice: Android

The project group had to take into account several conditions when choosing which mobile operating system we wanted to develop our project's application on. The first thing we had to consider was price. If we wanted to develop our application using iOS, the group would have to invest in a Mac in order to build it. However, both the Android OS and the Windows Phone OS requirements are setup to be more compatible with the hardware the group already owns, so development on both platforms would be relatively cheap. Next the group took user count into consideration. Android leads the trio of mobile operating systems by a lot with them having almost all of the market share is made up of phones with their operating system. While android has the most, iOS has a relatively adequate amount of users with their operating systems taking about a fifth of the market. Now while those two have a good amount of users, Windows Phones do not even come anywhere close to the other two in user population size. Not too many people use Windows Phones. Finally the project group had to take into account which platform will be the best to work on giving the skills that the group are already in possession of. No one in the project group has any experience working on iOS or Windows Phone development. However, between Windows and iOS, Windows Phone OS would be easier for the project group to work with due to the fact that the group does have some familiarity with the programming languages being used for development. But the group does have experience with working on Android Studios as well as being familiar with the programming language being used. So with taking price, user base size, and accessibility into account, the project group has decide to use the Android operating system for the development and platform of the project's application.

3.3.9.2 Computer App

For the Computer App, the group has set out to develop a platform that will allow the users freedom too many aspects of what can be customized for the table as well as provide some information to the players such as leaderboard, player progress, etc.

The milestones for the Computer App, or to be more precise, Web App, are as follow:

- Allow users to view leaderboard of everyone who has played on the table.
- Allow users to create different animations that will later could be imported to table via the smartphone.
- Allow users to look at player profiles and stats.

Web App Technologies

When developing a web application, there are several aspects that the project group must take into consideration when thinking about which technologies the group should use in development. One condition that the project group would need to take into consideration is whether or not the technologies can handle all the different assets that the project group wants the project's web application to contain. Another such aspect would be the experience the group has with the technology. Even if the group does not have any experience in the technology, the project group will have to also have to determine whether or not the technology would be relatively easy enough to learn. The following is some basic technologies that are needed together in order to create a Web app.

HTML5

Hyper Text Markup Language, HTML5, by itself is used to write websites. Just by itself, it basically does the layout a website. This layout can be considered a static type of web page design because by itself it cannot implement dynamic changes within the web page. In order to add some sort of style to an HTML5 web page, other components are needed such as Cascading Style Sheets (CSS) and JavaScript.

CSS

Cascading Style Sheets, also known as CSS, were created specifically for styling HTML web pages. It does everything to style the web page such as the font family, font color and page layout.

JavaScript

JavaScript when used alongside HTML5, it is used to make changes to the HTML images and elements. Also, JavaScript handles forms and their validation.

DHTML

DHTML is essentially Dynamic HTML. It is basically a culmination of the previously mentioned technologies, HTML5, CSS, and JavaScript. What DHTML does is that it enables users to create interactive and animated web sites. It allows pages to change at any time without returning to the web server. DHTML can allow various style implementation to a web page such as animation of text and images, embedded ticker, form inputs, drop-down menus and more.

So far, knowing what DHTML is capable of allows the project group to determine that it would satisfy most of the needs that the group wants to implement for the projects web page. The DHTML can handle the creation of a profile page that will handle the player's information. Also, the web page is capable of holding a link to

an applet to handle the table customizations. However, DHTML does not handle server side information so the group would not be able to implement the leaderboards for the game. So, DHMTL is capable of handling most of the desired design that the project group has in mind for the project web page but not all of them.

Using this method consists of learning HTML 5, CSS, and JavaScript. Most of the group has prior experience working with the previously mentioned technologies. However, learning how to use these technologies are relatively simple. So whether or not the project group is familiar with the technologies within DHTML, it would be easy enough for the project group to learn and work with it.

PHP

PHP: Hypertext Preprocessor known shorter as PHP. Just like DHTML, it is a culmination of the technologies HTML5, CSS, and JavaScript. PHP, like DHMTL, can generate dynamic page content, can collect form data, and send and receive cookies. However, unlike DHTML, PHP can edit and read files on the server, and can also add, delete, and modify data in the database. So PHP deals with server side scripting while DHTML does not.

Taking into consideration of the capabilities of PHP, the project group can determine that PHP would satisfy most if not all of the designated aspects that the project group wants the web application to have. Like DHMTL, PHP can handle the creation of a profile page that will handle the player's information. It can also give access to an applet in order to implement the table customizations. While DHTML could not handle the creation of a leaderboard, because PHP does server side scripting. So using PHP to develop the Web page will allow us to embed a database and actively update the data within. With all of the information present, the project group can determine that PHP would be adequate enough to deal with the designs in the development of the project group's web application.

So just like DHTML, PHP also consists of HTML, CSS, and JavaScript. However it also includes its own scripting language in itself, also called PHP. As was stated before, the project group has prior experience when dealing with HTML, CSS, and JavaScript. Even without that previous experience, those technologies would be easy enough for the group to learn for the project's web application. In addition to the previously mentioned technologies, the project group is also familiar with working with PHP. PHP is also relatively easy to learn so even if some of the project group does not know how to work with it at first, it should be quick to pick it up and be able to work with it on the project's web application.

ASP.NET

ASP.NET (Active Server Pages .NET) has a program model that works similarly to the previous mention technologies of DHTML and PHP. Web Pages is the programming model for ASP.NET that provides an easy way to combine HTML, CSS, JavaScript and server code. In this case, ASP.NET is more similar to PHP.

However, instead of using the PHP programming language for scripting, ASP.NET handles server scripting with Visual Basic or C#.

The first thing the project group needs to take into consideration is whether or not ASP.NET can handle the implementation of the project's web application. ASP.NET, like PHP, combines HTML, CSS, JavaScript, and server code. Since ASP.NET and PHP can handle and execute similar operations when it comes to web application development, the project group can make the assumption that ASP.NET could handle all the aspects of the project's web application should the project group choose to work with it.

Just like DHTML and PHP, ASP.NET consists of HTML, CSS, and JavaScript. For ASP.NET, it also handles server scripting with the Visual Basic or C# programming languages. As stated before with DHTML and PHP, the project group has prior experience when dealing with HTML, CSS, and JavaScript. So getting familiar with ASP.NET should not be too difficult for the project group. Even if the project group did not have any familiarity with HTML, CSS, and JavaScript, these technologies are relatively easy to learn and pick up. So even without prior experience, at least that side of ASP.NET would be easily picked up by the project group. The next aspect of ASP.NET that the project group would have to worry about would be the server scripting. In this case the project group would have to use Visual Basic or C#. As of the time of writing this document, the project group does not have much if any experience using Visual Basic. However, the project group does have some experience with C#. So getting used to the server side scripting of ASP.NET, should not be too difficult as long as the project group uses the programming language of C#. With all the included technologies of ASP.NET, should the project group decide to use it, ASP.NET should be relatively easy enough for the project group to get used to.

Web App Technologies Choice: PHP

The project group choice for the web application technology consisted of three different choices which were DHTML, PHP, and ASP.NET. All three of these choices consist of a combination of HTML, CSS, and JavaScript. However, both PHP and ASP.NET have server side scripting which allows them to handle databases. Due to the fact that DHTML does not have a way to handle databases, the project group has ruled out the possibility of using it. Even though both of the remaining databases have server side scripting, PHP uses itself as the programming language that handles that scripting, while ASP.NET uses Visual Basic and C#. While the project group does not have much experience when it comes to using Visual Basic, the group does have experience when it comes to the programming languages of PHP and C#. Not only that, but both technologies can support with all that the project group wants to implement with the web application. However, due to the fact that the project group has a little more experience dealing with PHP, the group has decided that PHP will be what is used for the project's web application.

Animation Applet Technologies

For the animation applet for the project we need a technology that can handle the implementation of the LED table's customization themes. The LED table customization are going to be handles in an applet that is embedded into the project's web page. Some of the things the project group has to take into consideration for choosing this technology is which technology is readily accessible to the project group given what the group has experience in. Besides that, the project group just has to determine whether or not the animation applet technology has the features needed in order to create what the project group needs to for the animation applet.

Java

One of the implementations of applets the project group is thinking of using is the Java applet. To write a java applet, the group would need to be familiar with programming in Java programming language. It can be used in a variety of Java supported IDEs such as Eclipse which the project group is very familiar with it. To embed the Java applet into the web page is to just add some lines to an HTML file. This way of developing the applet can be immediately picked up by the project group.

Flash

The next applet technology the project group is considering is Flash. Flash applets are created in xml files. These files can be edited in numerous IDEs like Code Blocks, which the project group has previous experience with. Although the project group can readily start developing on a Flash platform, the tools for flash development are not free. However, compared to Java, Flash applets are known to be faster and more stable than the Java applets.

Jython

Another applet development technology that the project group has taken into consideration is Jython. Jython is an implementation of the python programming language designed to run on the Java platform. Jython is capable of handling anything a Java applet can handle so it is suitable for this project. Jython, as the name indicates, is a combination of python and Java modules. So since our project group has experience in both programming in Java and programming in python, Jython is a viable option to develop the projects applet.

Animation Applet Technologies Choice: Flash

Although there may be a monetary expense with it, the group has decided to try and implement the project's design applet by using Flash. Although our group is familiar with Java and Jython our group has decided to go with Flash for several reasons. First is that flash is known to be faster and has a more stable

implementation than Java. The group did not want to work with Jython due to the fact that Python applets have known to be slower and the group prefers not to work with python again.

3.3.9.3 Database

The database for the project will require to store various information for the project such as user information and game history. This information will be presented on the web application and smartphone application. When it comes to how to decide which database to use, the project group must take into account whether it can handle what the project group needs it to do. The project group must also take into account the accessibility of the database to allow the project group to get a better understanding of the database.

MS SQL Server

Microsoft SQL Server is SQL scripted database management system. Their standard version has several key missing components. This does not have hot-add memory which is what allows memory to be added while the server is still running. However, due to it being a SQL scripted server, the group would not have any problems working with it due to the fact the group has a lot of prior experience handling SQL.

IBM DB2

IBM DB2 is the next database server system that the project group was considering. For scripting, the database uses SQL and XQuery. IBM DB2 has APIs for various languages that include C, Java, and PHP which are all languages the project group is acquainted with. The project group is also familiar with Eclipse which supports the integration of DB2. Given all the familiar aspects of the database server system, IBM DB2, the project group can safely assume that it would be possible to use this server system to handle the database of the project's system.

MySQL

MySQL is an open source database that uses SQL scripting. Of all the databases, the project group has the most experience working with MySQL. It is a free database service that has all the capabilities needed for the project. So, the project group can be confident in the decision that MySQL can be used as this project's database system.

Database Choice:

All options of databases that the project group has explored, are all viable options for this project. However, due to the fact that its better financially and that the

project group has previous experience with it, the project group has decided to work with MySQL for the database needs of the project.

4.0 Standards

4.1 Safety Standards

Our project will involve some specific safety concerns that need to be met in order to insure that it will be able to function in the presence of untrained users without being a threat to their safety. One such concern is the fact that our project is an electrical device that is specifically designed to interact with water. To insure that those interacting with the table will not be in any danger from the spills of liquids, several standards will be used for reference in implementing our design.

In addition to the concerns with exposure to liquids, we need to be sure that our table will be able to support the weight of the equipment involved in its design. There are a few basic standards (E2126-11) that we can use to test the strength and stability of the materials involved to make sure that they can sustain the weight and even deal with the possibility of moisture absorption. We will examine these and use them to determine our methods of testing.

4.1.1 ASTM D2633-13a

This standard specifically concerns the jackets used for wires and testing them for usability purposes. Taking some information from this standard could be important to insuring that our waterproofing methods are safe enough. If they can match up to this standard we can definitely have some safety assurance since most cable jackets have a small level of waterproofing. That said, we may not necessarily use wire-jackets specifically, but something similar to them like a waterproof seal on a wall.

The properties that the wire-jackets were tested for include a water absorption test to determine how they react in a wet environment. The test specifically requires that the wire jackets be kept at a certain temperature and then cooled before being submerged in water that is kept within a specific range of temperatures for a period of 14 days. Afterwards, the jacket is removed and its properties are examined to determine if any significant wear has occurred. Specifically, they look at the thickness of the insulation, the capacitance values, and the conductor's size. If these properties change beyond acceptable values, then they know that the jackets are not suitable for their purposes.

For our case specifically, we rely on these test examples to build test of our own in determining the safety of our device. We can test our own wire-jackets to this same standard if we desire, or adapt them to test other materials that will be involved in its design. The basic idea is to submerge and object and judge its changes after several days, so we may try this approach on the surface of our table

to determine if it will absorb any excess liquids. We could also stage tests to determine if leaking occurs by using materials with absorbent properties to plug crevices in the table as a test to see if they have to absorb any liquids as a result of insufficient water-proofing in our design. The exact tests developed for our design will be discussed later.

4.1.2 ASTM D2395-14

This standards specifically concerns how to test “wood and wood-based materials” to determine their “specific gravity (relative density)” (D2395-14). Testing this property of the materials involved in our table’s structure is necessary to determine whether or not it will be able to support the load of all of the equipment involved in its design. Once our building materials have been tested, we can decide what to use for the physical framework of the table and fit our device components in as needed.

There are six different test methods given in the standards: Volume by Measurement (Method A), Volume by Water Immersion (Method B), Flotation Tube (Method C), Forstner Bit (Method D), Increment Core (Method E), and Chips (Method F). Method A is designed for objects that have smooth surfaces and regular shape because they can easily be measured and their mass determined through calculation, but when objects have a rough or uneven surface and/or an irregular shape to them, it is more viable to use Method B. Method C isn’t as accurate, but can be used easily if precision isn’t heavily required. Methods D and E are actually built for handling the measurement of living trees or “in-place elements” (something that is too difficult to obtain a smaller sample of to examine easily) that can’t be easily measured and therefore need to be implemented carefully to insure accuracy. Meanwhile, Method F is simply meant to be used for measuring the density of wood chips. Between these different options we should easily be able to determine the properties of the materials we consider in our table’s framework.

For the purposes of our design, we should be able to effectively determine the density of our building materials from Method A. This was designed to handle the measurement of objects at any moisture content as long as they are regular in shape and have smooth surfaces. We can easily find our build parts for our table with those properties. As for the other test methods, Method B would only be viable if we waterproofed our building materials first, which may become a necessary addition to our design but shouldn’t be involved with our tests of structural stability. Method C only works on objects with a slender shape, and does not provide the same level of accuracy in this case that we can afford with Method A. Method’s D and E are unnecessary because we aren’t testing a living, organic specimen and or are we measuring the properties of an “in-place element”. Lastly, Method F is meant for wood chips and our table will not be built with wood chips so much as whole pieces of wood. As such, Method A best suits our purposes and can be used to determine the density of our building materials, and consequently their mass.

This information can then be used for determining strength test calculations and static structural stability calculations in our design.

4.1.3 ASTM D4442-07

As part of our project, we need to determine how much moisture has been taken in by the framework of the table because it could potentially damage the structural stability. It could also be a safety hazard because of the possibility of the moisture reaching the electrical wiring. This standard specifically concerns how to determine the moisture content of “solid wood, veneer, and other wood-base materials, including those that contain adhesives and chemical additives” (D4442-07). This will allow us to waterproof our materials for the table, then test them to determine if they have taken in excess moisture.

To specifically test whether or not our materials have taken in moisture, there are four different methods: Primary Oven-Drying Method (Method A), Secondary Oven-Drying Method (Method B), Distillation (Method C), and Other Secondary Methods (Method D). Method A is considered to be the most accurate, but is not always desired or justified to use. The process requires that the object under testing be placed in an oven and dried until no change in its weight can be detected. A calculation is then run based on the gathered information to determine the moisture content that the object originally had, but it requires the use of “fresh desiccant” which may not be available to us. Methods B and D will prove easier to implement by comparison as they use materials more available to us, but in general require the same method of measuring an object’s weight before and after drying it to determine the amount of moisture that was contained within it. Meanwhile, Method C involves a very complicated chemistry procedure to extract water from the wood. Regardless of method, each of them has special procedures to account for the addition of chemicals to the wood when determining change in moisture, so they can be very useful to our project.

Most likely we will be using either Method B or D, depending on the supplies we can acquire. We will attempt to obtain those necessary for Method A, but they include “desiccant” and “closed weighing jars” which we may not be able to find. Method C is unnecessarily time consuming and inefficient for our purposes, so it is better that we avoid using it for our tests. With that in mind, Method B should prove sufficient for our purposes, provided that we can find all of the materials for it. If the materials are unavailable, we will look up the alternative methods described in Method D and make use of them instead. Thus, these methods should allow us to test our waterproofing of the table’s framework and insure the safety and stability of its design.

4.1.4 ASTM E564-06(2012)

This standard specifically concerns how to determine the static load that a structure is able to support to prevent it from toppling over its side. Our table needs to be able to support the weight of the equipment and devices involved in its

design, common cups, and possibly even the weight of people leaning against it. Therefore we will need to use tests from this standard to determine the ability of our table to resist these common forces that it will encounter in regular use. Specifically though, this test will tell us how well our table is able to resist being flipped over one of its sides.

This was specifically designed for testing walls built along-side support columns rather than the columns themselves, but should still provide useful information to determine the stability of our table. The basic test for determining the load a structure can support is determined by "anchoring the bottom edge of the wall assembly and applying a force to the top edge oriented perpendicular to the wall height dimension and parallel to the wall length dimension" (E564-06(2012)). This basic test is meant to apply the concept of "moment about an axis" to the structure in question and use the base of the structure as its axis. By keeping the "bottom edge" of the structure anchored and then applying force to the "top edge" we can determine how much load the structure can withstand without breaking along the length of its height. These tests are called "forcing a racking deformation", and a minimum of two different tests are required as part of this standard to determine a structure's stability when force is applied on either side of it.

The following is the explanation given in the standard on how to perform the test: "Racking loads shall be applied parallel to and at the top of the wall, in the central plane of the frame, using a hydraulic jack or similar loading device capable of maintaining a constant displacement rate for continuous load to failure or holding a static load in the case of incremental loading. Loads shall be applied at a constant rate of displacement to reach the target limit (that is, limiting displacement of ultimate load) in no less than 5 min" (E564-06(2012)). We specifically may not be able to obtain a hydraulic jack and may need to use an alternative means of applying force to the structure to determine its stability. We also need to test its strength against a load situated directly on top of the table instead of against the side as a test to determine if it can sustain the load of our equipment, cups in play, and any human weight that may come into play. In any case, this standard should prove very useful to insuring the safety of our design.

6.0 Hardware and Software Design Details

6.1 Initial Design Architecture and Related Schematics

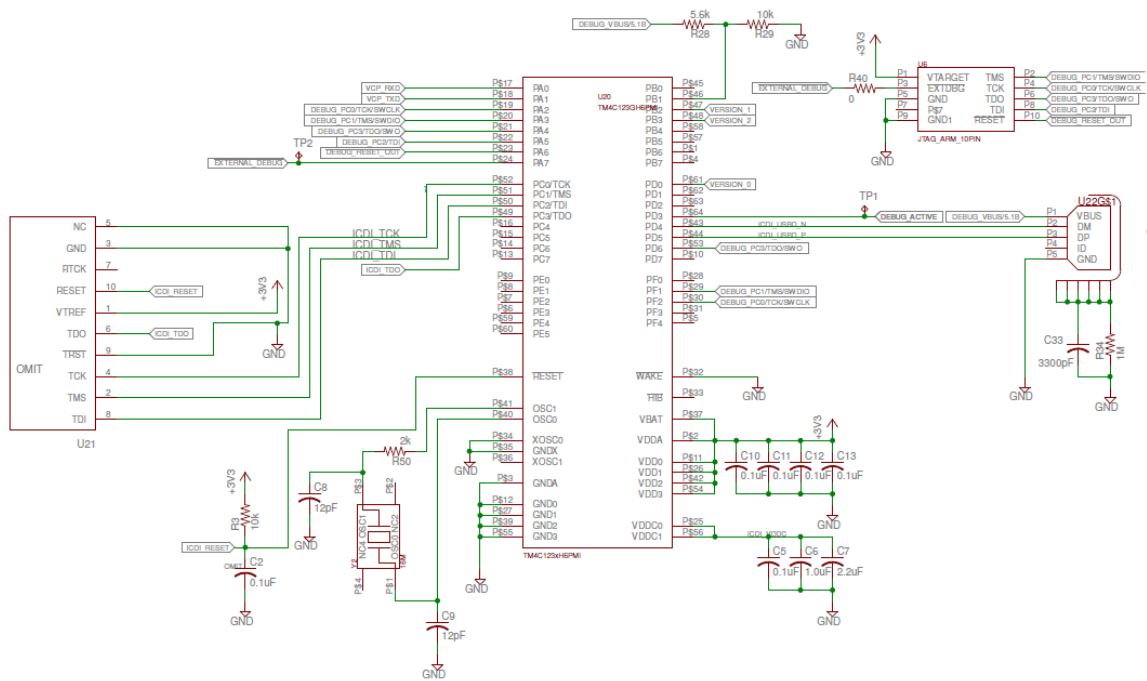

Figure x.xx: Initial Functional Schematic of TM4C123GH6PM Microcontroller

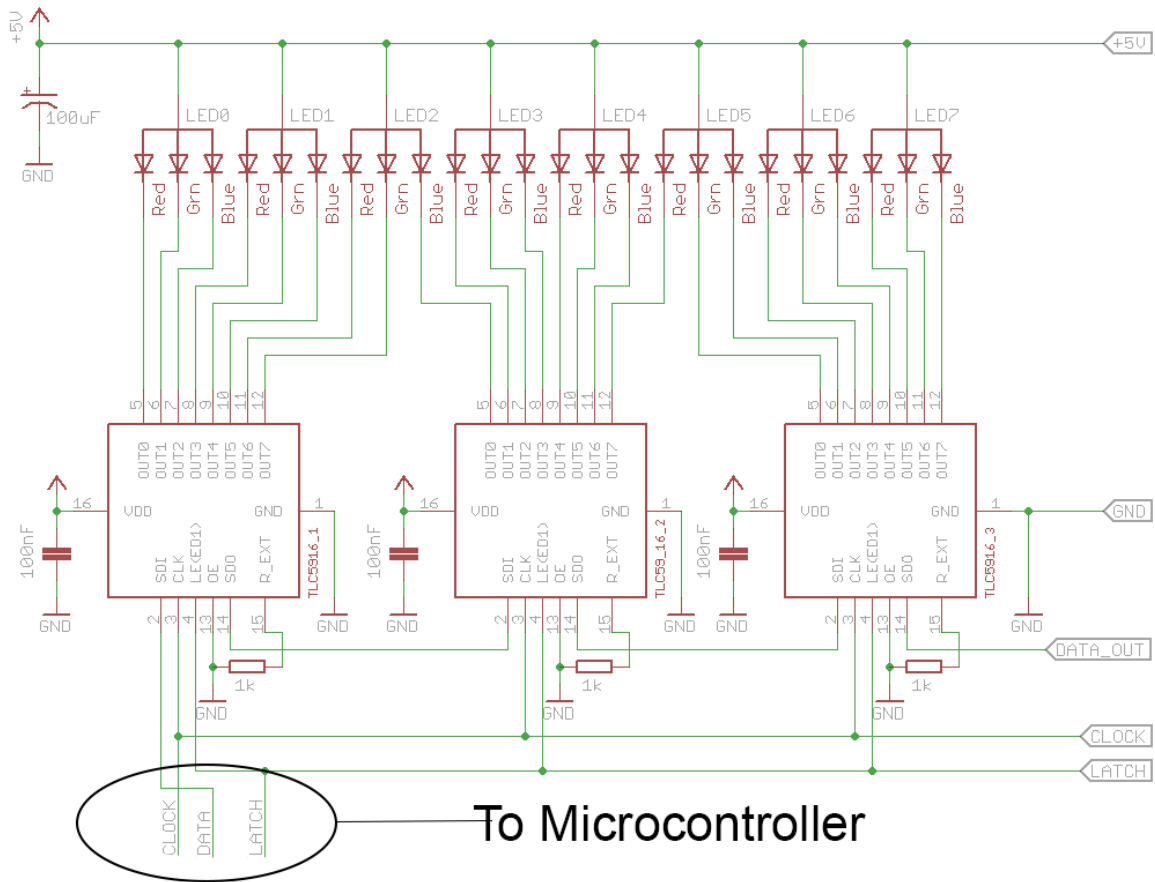

Figure x.xx: Initial Schematic of Cascaded TLC5940

Note: This is an initial cascaded TLC5940 of our project. Having a schematic that would cover all of the TLC5940 required would require a bigger working space, not provided by the freeware version of EAGLE.

6.6 Ball Cleaner

When designing the Ball Washer we looked at prices, technology, and efficiency, safety, and design constraints. For the first part of the design we chose between an air flow system, water pump system, and both. To prevent from having the necessity of having to change out water and have a smaller budget we chose to design an air flow or fan system. Although an a water system would clean the ball more than an air system the main reason the balls get dirty is due to them being wet and falling onto the ground. If the ball is dried first then the less likely they are to attract dirt. Thus we decided to design a fan-based system that will dry the ball and remove residue using the wind generated by the fan.

Piping/Tubing

To move the ball across each side of the table we must construct a pathway leading it to its desired position. To do this we use piping. As discussed in the research tab we looked at various types of piping to be used. We chose PVC due to its ability to be cut and glued together easily and the various connections that can be used. Ping Pong balls size varies between 38mm and 40mm. 38mm ping pong balls were the previous specification before the 2000 Summer Olympics and is now currently changed to the 40mm size. 40mm size balls approximately are just slightly larger than an inch and a half. Since PVC is measured in US customary units we have to convert it to metric to see what piping is just big enough for the ping pong ball to fit. There is two types of PVC piping which concerns the size of the piping wall. Schedule 40 and schedule 80 are the two types of fittings. Although the wall is bigger the inside parameters stay the same allowing the same size flow. This means the outside overall parameter is different between the two. Since a ping pong ball only weighs xxx we do not need to use the schedule 80 for this design. We will use Schedule 40 which is cheaper and more common and easier to find in stores. The two sizes that range close to the ping pong ball size are 1-1/2" and 2". The conversion is shown below:

$$\text{millimeters} = \frac{\text{inches}}{0.039370}$$

Thus,

$$\text{millimeters} = \frac{1.5}{0.039370} = 38.1\text{mm}$$

$$\text{millimeters} = \frac{2}{0.039370} = 50.8\text{mm}$$

The 1-1/2" is slightly too small for the ping pong ball to pass through and 2" leaves enough room for the ball to have small friction when moving through. But these calculations are misleading. Even though the PVC pipes say it is 1-1/2" it is not exactly that size. The PVC we chose to use 1-1/2 in. x 10 ft. PVC Sch. 40 DWV Plain End Pipe is actually 1.593 inches in the inside of the PVC which is slightly over 40mm at 40.5mm. Thus we can actually use the 1-1/2" PVC for this design. Below is a diagram of how the PVC will guide the ball to the other end and its parts.

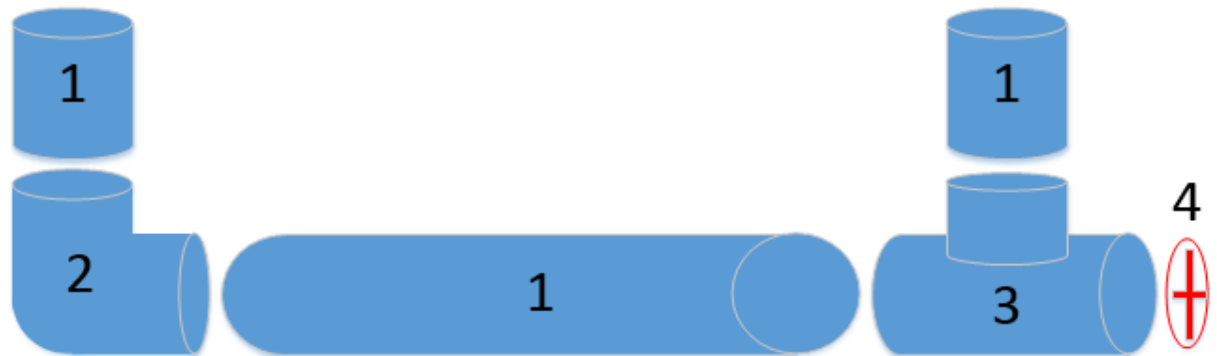

1 – 1-½" (40mm) PVC Pipe

1 – 1-½" (40mm) PVC 90° Coupler

1 – 1-½" (40mm) PVC T-Coupler

4 – 12V DC Motor and Blade

Figure: Parts for Piping Connection

Fan System

For the process of driving the ball through the tubing we have the choice of a prebuilt fan or motor with a blade connected to it. It is basically the same design but motors are easily changeable and customizable. For this case we will implement a motor into the design to force the ball through the piping. The motors looked at included a stepper motor ROB-09238 and an Electric high torque motor made by Uxcell. The stepper motor has the same voltage input as the Uxcell motor but draws less current. This is a good and bad thing. This tells me two things; one is that it draws less current which is good because it requires less from the power

source; and two, it most likely doesn't have as much speed as the Uxcell motor. The stepper motor and Uxcell motor both draw 12 volts DC but the stepper motor draws 0.33 Amperes, where the Uxcell motor draws 1.8 Amperes. The Uxcell motor has a speed of 15000 RPM (rotations per minute) which very high and it desirable for this design being able to push the ball with more than enough force. The motor also allows interchangeable blades to use allowing for speed changes also. It is made of metal so we know it is sturdy. The motor will typically require the most power in this project and safety measures must be taken to protect the circuit. When the motor is turned off and the blades are slowing down the motor can sometimes try and push electric current back into the circuit. The DC motor is the most basic part of the design but has an important role. The motor is placed as shown below and pushes the ping pong ball in the direction shown.



Figure: Air Flow of Piping System

Microcontroller

The table below shows the top companies and possible microcontrollers to use and their specifications. This is an easy way to compare and contrast microcontroller from each company.

<u>Category</u>	<u>Specifications</u>			
Company:	Texas Instruments	Microchip	Atmel	Atmel
Microcontroller:	MSP430F1611 IPM	PIC24F04KA200	AT90CAN128-16AU	ATmega328
Data Bus Width:	16 bit	16 bit	8 bit	8 bit
CPU Speed (MHz):	8 MHz	8 MHz	16 MHz	20 MHz
RAM (kB):	10 kB	.512 kB	4 kB	2 kB
Flash Memory (kB):	60 kB	4 kB	128 kB	32 kB
Operating Temperature (C°):	-40 C to +85 C	-40 C to +123 C	-40 C to +85 C	-40 C to +85 C
Supply Voltage (V):	1. - 3.6 Volts	1.8 - 3.6 Volts	2.7 - 5.5 Volts	1.8 - 5.5 Volts
Number of I/Os:	48	12	53	23
Number of Channels:	8	7	N/A	6

Pricing (\$):	\$18.13	\$1.46	\$10.19	\$3.24
---------------	---------	--------	---------	--------

The Atmel ATMEGA328-PU seems to be the most exceptional for the price. The Texas Instruments MSP430F1611IPM doesn't have a high input voltage and it is extremely expensive compared to the other three choices but doesn't impress enough for the price difference. The Microchip PIC24F04KA200 just doesn't cut it in memory size and also has a smaller input voltage and much less number of I/Os. Atmel seems to provide extremely useful microprocessors at high efficiency for a lower price than Texas Instruments. The Atmel AT90CAN128-16AU has a better memory size and number of I/Os but lacks in speed compared to the Atmel ATmega328. The Atmel ATmega328 has plenty of channels and I/Os for this design and has the fastest CPU speed of all four choices. The price of the Atmel ATmega328 is much lower than the both the Texas Instruments MSP430F1611IPM and the Atmel AT90CAN128-16AU and outplays the Microchip PIC24F04KA200 in almost every category. The Arduino UNO Rev3 contains the ATmega328 and supports everything needed on the microcontroller.

Sensor

When looking at sensors we needed to find one small enough to sense inside the tubing but effective enough to detect a fast moving ping pong ball being dropped through the tubing. We found that the TCRT5000 has been used in previous projects and designs used with the microcontroller we chose. The TCRT5000 is a reflective sensor that has both an infrared emitter and phototransistor in a leaded package that blocks visible light. It has four leads on it two coming from the infrared emitter and two from the phototransistor. The two from the infrared emitter are an Anode and Cathode lead and the two from the phototransistor are a Collector and Emitter lead. We thought about using an IR LED receiver only but we have seen the previous Sensor be tested and work properly on previous projects detecting fast movement so we went with the TCRT5000. The TCRT5000L is the TCRT5000 but with longer leads making wiring much easier.

Wiring Schematic

When designing the electrical schematic we have to make sure enough power can be supplied to the DC motor without burning up the system from too much current. We also have to supply power to the Sensor but this can be done using the microcontroller output voltage. To power the motor enough to spin fast enough to force the ball through the piping it will require quite a bit of current. The motor chosen has a maximum of 1.8 Amperes. This is quite a lot more than what the microcontroller carry thus we have to use power from a separate power supply. The microcontroller cannot handle the amperage flow of the power supply we will use to power the fan. Thus we must use a separate component to handle the current but be controlled by the microcontroller. Thus we add a relay to the circuit because it can handle the current flow and control the motor from the

microcontroller. Relays are electromagnetic switches that have a very high AC and DC current rating. The relay isolates the motor from the circuit and acts as a switch allowing voltage flow to the motor. Relays have a switch inside that when a voltage is applied across the electromagnet the switch moves to the other contact allowing flow. Thus when the small voltage from the microcontroller is sent to the relay using a PWM pin it can open or close the switch inside the relay which controls the path of current being sent to the motor. When the relay is open then the circuit to the motor is open and when the relay is closed the path to the motor is reconnected and allows the current to flow to the motor and power it on. Thus when the fan is turned off and the current get pushed back into the circuit by the blades still spinning, the circuit is open and can't burn up anything. If the motor was powered straight from the microcontroller we would have to worry about the current flowing back into the microcontroller from the motor. With the relay this eliminates the chances of current back flow. The terms associated with relays include Normally Open (NO), Normally Closed (NC), and Change Over (CO). These terms refer to the connections or contacts the relay circuit has. The normally open contact connects when the relay is activated or powered and connects to the positive end of the power supplied. The normally open contact connects to the common when the coil in the relay is charged. The normally closed contact disconnects the circuit when the relay is activated and is connected to the common when the coil is not charged. The change over contact normally known as the common contact connects to either the normally open contact or normally closed contact at one end and to the motor in this case which is connected to ground from the motor making the circuit complete. To switch the relay and charge its coil we need a separate voltage to do so. We looked at normal relays and none of them compared to the SainSmart 2-Channel 5V Relay Module which connects right to and is controlled by the Arduino Microcontroller. The SainSmart 2-Channel 5V Relay Module requires a 5 volt input with 15-20mA current to drive each switch. The relay itself can handle high current and voltage rates up to 30 volts DC and 10 amps. The SainSmart 2-Channel 5V Relay Module can also be controlled directly from microcontrollers such as Raspberry Pi, Arduino, 8051, AVR, PIC, DSP, ARM, ARM, MSP430, and TTL logic. The motor positive contact is connected to the common contact of the relay while its negative is connected to the ground. The relays normally open contact is connected to the power supply supplying power essentially to the motor. The relays normally closed contact is left open so the motor does not run when turned off. The common contact of the relay as said before is connected to the motor positive contact. When connecting the relay to be controlled and charged by the microcontroller there are three pins that are used. The first is the data IN1 pin that controls the relay module. This is connected to a digital output on the microcontroller. The second pin used is the VCC pin which supplies the relay module with power and charges the coil. This pin is connected to the 5 volts VCC on the microcontroller. The last pin on the relay module is the GND which just connects to the GND pin on the microcontroller. Thus the motor is wired and the next thing to wire is the infrared emitter and phototransistor. This component has four pins two coming from each. The infrared emitter Anode contact connects to a power source and the cathode is run to a ground. The

phototransistor has two pins which are a collector that connects to a power source and digital output and an emitter that connects to ground. Possible resistors might be implemented when testing the sensor due to current drawing. Below is a schematic of the complete wiring system.

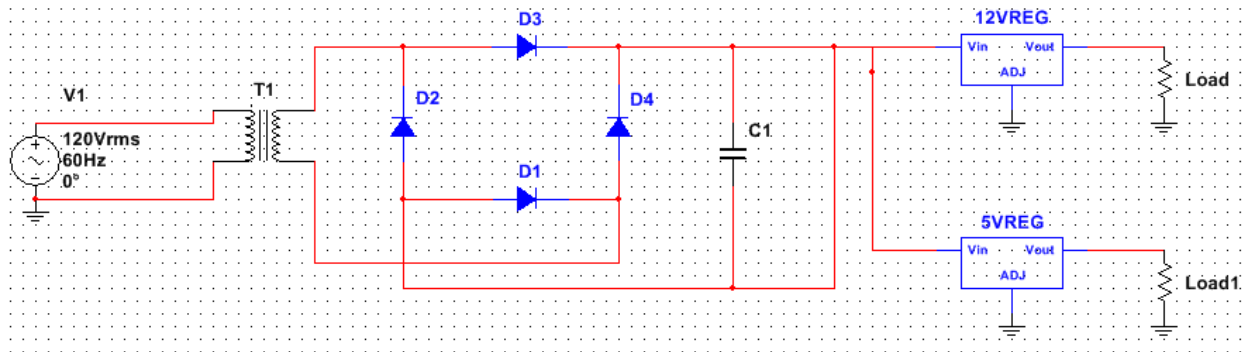

Figure: Basic Schematic on Multisim of Electric Circuit

6.7 Power Supply

When building an AC output to DC output power supply and designing it, the steps in doing so are very similar despite the type. The methods of designing an unregulated power supply apply to regulated power supplies also. Regulated power supplies go through all the steps of an unregulated power supply but add the regulation or control of the output power. The first step in designing both is to change AC output into DC output. This step is called Rectification. The first thing to know is the basic standards for voltage coming from the power source. The North American standard for a normal outlet that we are using is 120 volts AC at a frequency of 60 Hz. From here we know the input into the power supply and can start designing hence forth.

Step Down Voltage

The first step in rectification is to step down the AC input to a lower AC input that is more suitable to use. This process is called step down and is done using a transformer. Transformers transfer electrical energy using electromagnetic induction using primary windings, secondary windings, and a core. Transformers are used to increase or decrease the voltage of an alternating current from an electrical device. To step up voltage in a circuit the transformers secondary windings has more coils of wire than the primary windings. Since we need to lower the alternating current we are using a step down transformer which has more coils of wire on the primary windings than the secondary. The alternating current in the primary coil produces a magnetic field in the core which then produces a potential difference in the secondary windings. If we were to assume the transformer worked

at 100% efficiency then the equation used to calculate the potential difference would be:

$$\frac{V_p}{V_s} = \frac{n_p}{n_s} \quad \text{and} \quad V_p \times I_p = V_s \times I_s$$

Half Wave Rectification

Once the step down of alternating current has been done then we are ready to convert the alternating current into direct current. Diodes conduct current only in just one direction going from the anode to cathode and not in the opposite direction. Thus it makes sense to use them to convert a two directional alternating current into a one-way direct current. The input form in AC shows a sinusoid that alternates between positive and negative half cycles. The output from a diode connected is rectified only having either positive or negative half cycles but not both. This type of design is called Half Wave rectification. A simple half wave rectifier is not a very complicated design. It consists of just a single diode. This diode is a pn junction diode which is connected into series to the load resistor. So in this design the input is the alternating current which has been stepped down by the transformer and the reduced voltage is given to the diode. During the positive half cycles of the input sinusoidal wave the diode is forward biased and during the negative half cycles of the diode it is reverse biased. Thus the diode only lets current pass through during the positive cycle of the wave. When the wave hits the negative half waves it instead reads a zero output. The disadvantage of a half wave rectifier is pretty obvious since the waves are not continuous, thus creating a high rippling effect. If we applied it to an audio connection then there would be a high amount of noise and result in a bad quality of audio output. The advantages of a half wave rectifier are that they are cheap and simple to make or apply. Thus a more reliable and superior design is to use a full wave rectifier. The schematic and input/output waveforms are shown below.

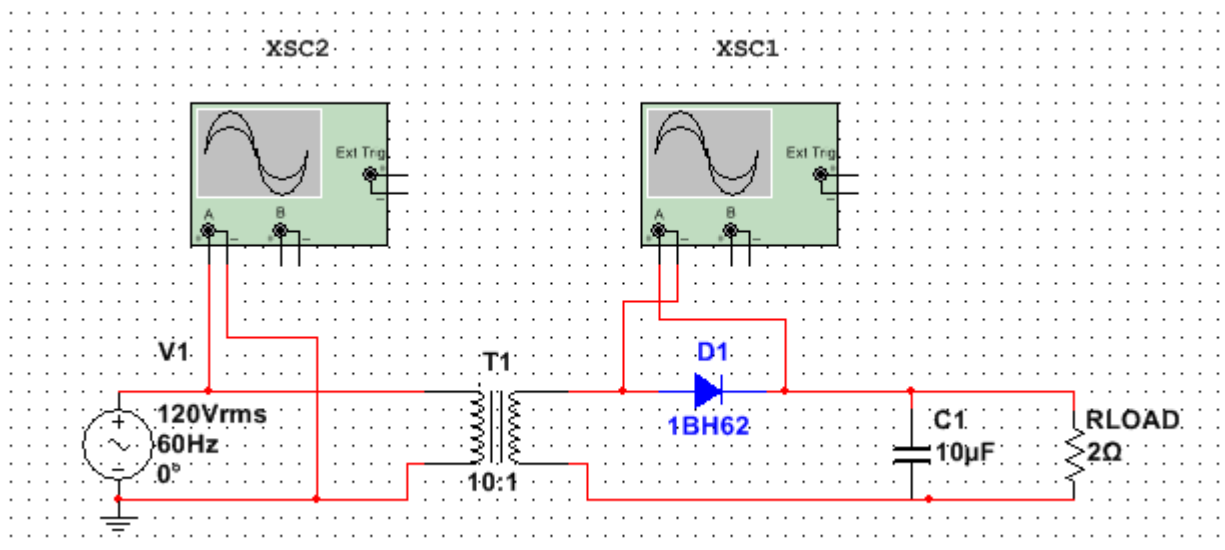

Figure: Half Wave Rectifier Circuit

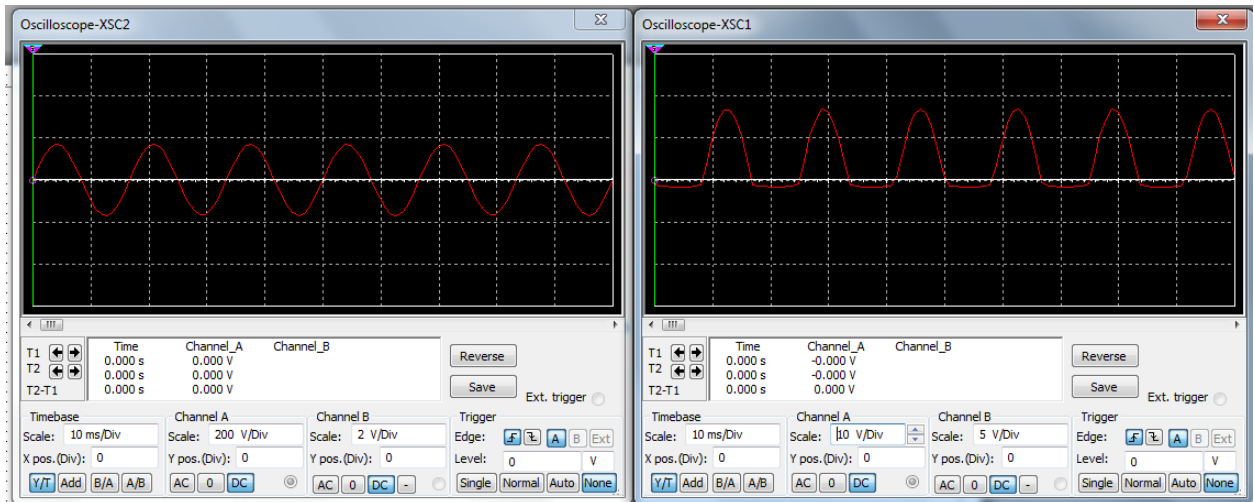

Figure: Half Wave Input waveform (left) and Half Wave Rectified waveform (right)

Full Wave Rectification

Just like a half wave rectifier a full wave rectifier consists of diodes. But instead of one diode, it uses more than one. In a full wave rectifier two diodes are connected to the circuit. The first diode is for one half of the cycle and the other diode is used for the second, eliminating the zero result from the negative cycle. This creates a continuous positive cycle in the output wave instead of a half positive waveform. In this design we need a transformer with a centre tap connection though resulting in a larger transformer. Each diode is connected to one end of the secondary windings on the transformer and the load resistor connected to the centre connection on the transformer. Each diode conducts in turn producing a half cycle each combining to make the continuous full wave cycle. The two diodes and resistance load are connected on the other end which allows the diodes to take turns supplying power to the load resistance. When point 1 of the transformer is positive with respect to point 3, the Dtop diode conducts in the forward direction. When point 2 is positive or also called the negative half cycle in respect to point 3, the Dbot diode conducts in the forward direction. Thus where the empty spaces are for a diode, the other diode is filling them in making the output DC voltage double that of a half wave rectifier. The schematic and output waveform is shown below.

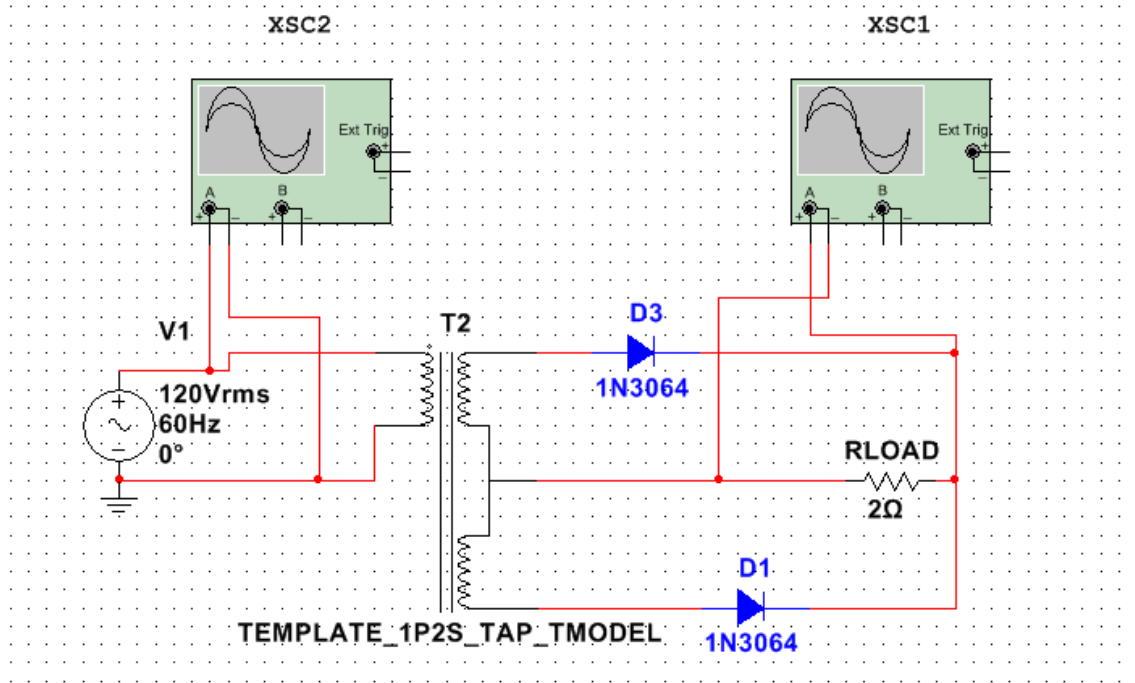

Figure: Full Wave Rectifier Circuit

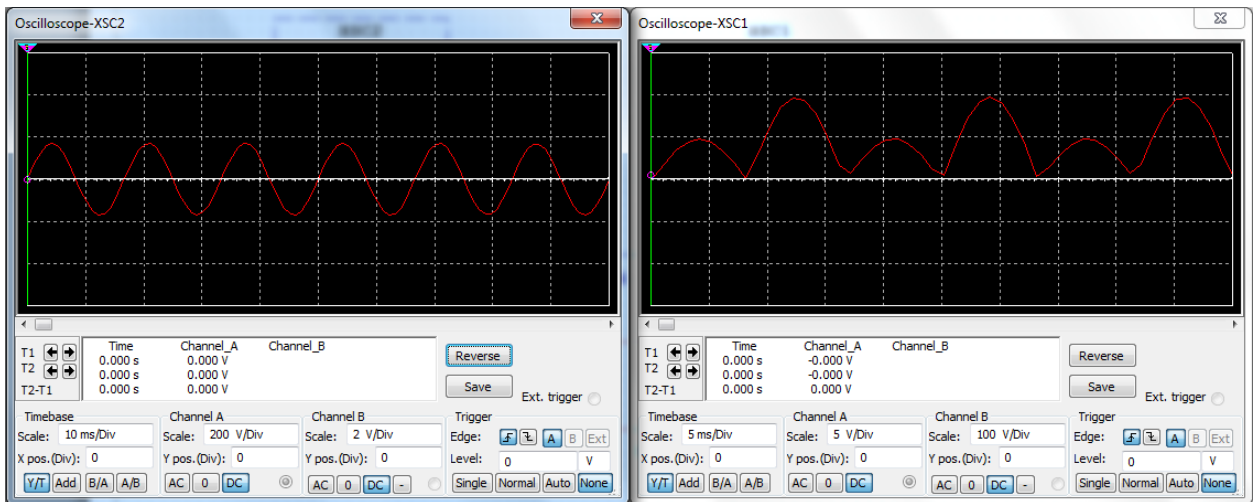

Figure: Full Wave Input waveform (left) and Full Wave Rectified waveform (right)

Full Wave Bridge Rectifier

To get rid of the center point in the transformer we use a full wave bridge rectifier. It produces the same output as the full wave rectifier but does not require the centre point of the transformer. Instead of two diodes in the full wave rectifier, the bridge rectifier consists of four individual diodes connected in a closed loop. Eliminating

this center point reduces the cost and size of the transformer and makes the schematic a minor amount simpler. The transistor secondary windings are connected to the full wave bridge rectifier as shown below. The four diodes are arranged in series pairs with both pairs producing power during each half cycle just like the full wave bridge rectifier. During the positive half cycle D1 and D2 produce an output and conduct in series while D3 and D4 diodes are reverse biased. During the negative half cycle of the input D3 and D4 are forward biased and produce an output in series but D1 and D2 switch to reverse biased. Although the direction of current changes in the rectifier and transformer, the current through the load remains the same during both positive and negative cycles. The figure below shows the direction of flow during both positive and negative half-cycles. You can make a full bridge rectifier using four diodes but there are premade bridge rectifiers in several different ranges and sizes.

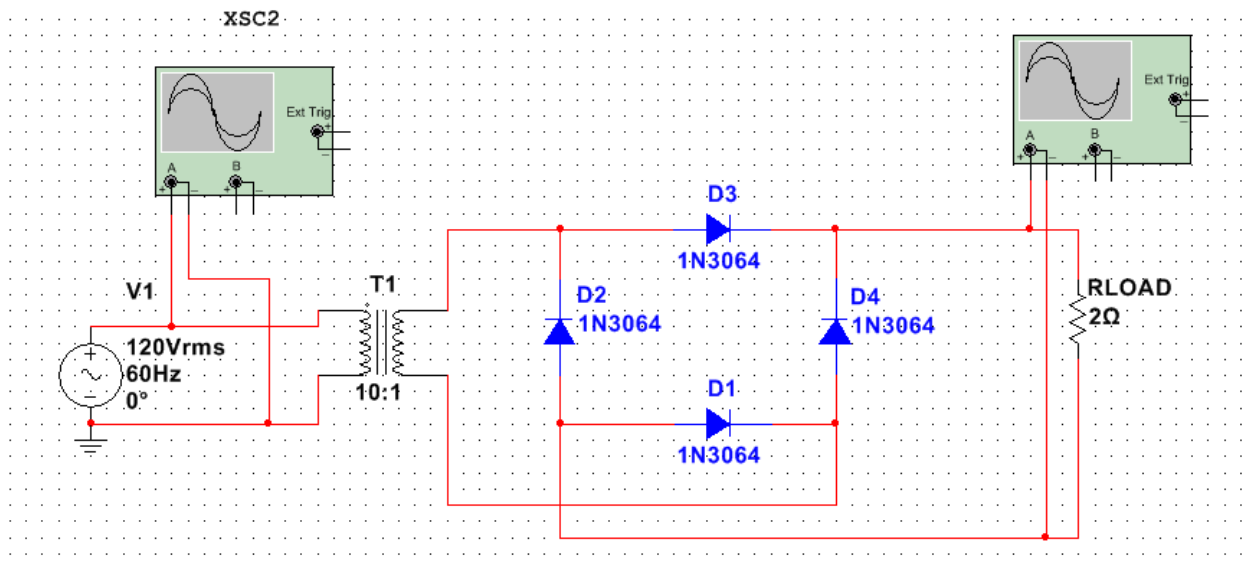

Figure: Full Wave Bridge Rectifier Circuit

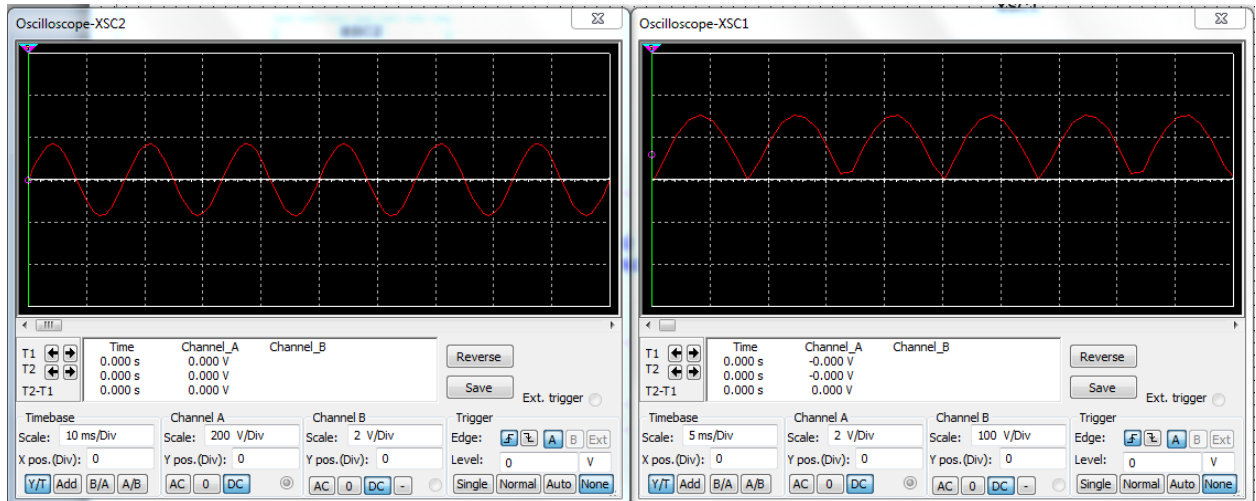

Figure: Full Wave Input waveform (left) and Full Wave Rectified waveform (right)

Smoothing Process

Before we start to regulate Power we want to cancel out as much ripple effect as we can. Smoothing is the process of stopping the DC voltage from the rectifier from falling. This is done by a high value capacitor acting as filler by applying current to the output when the voltage wants to decrease. The capacitor charges as the voltage reaches its peak then discharges smoothing out the output voltage. The smoothing capacitor converts the full wave output with ripples into a much smoother DC output voltage. When designing the smoothing capacitor into the circuit we have to make sure its working voltage is not higher than no-load output amount of the rectifier. The ripple voltage is not only affected by the capacitor but also by the frequency and current. We aim for a ripple voltage no higher than 100mV peak to peak, thus we use the formula below:

$$V_{(ripple)} = \frac{I_{(load)}}{f * C} \text{ (Volts)}$$

The fundamental frequency of a full wave bridge rectifier is twice that much of a half wave rectifier due to the doubling of its output waveform. Thus the Ripple voltage is half that of a half wave rectifier if the current load and Capacitor are the same ones used for each. Thus we can use a smaller capacitor for the full wave rectifiers and the smoothing is much cleaner as shown below.

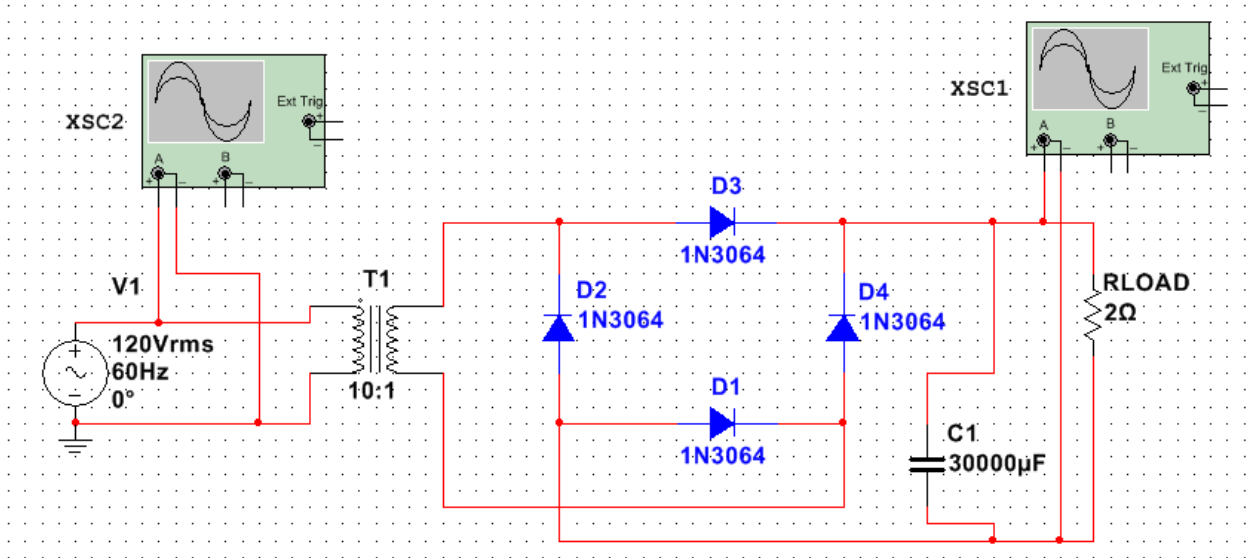

Figure: Full Wave Bridge Rectifier with Smoothing Capacitor

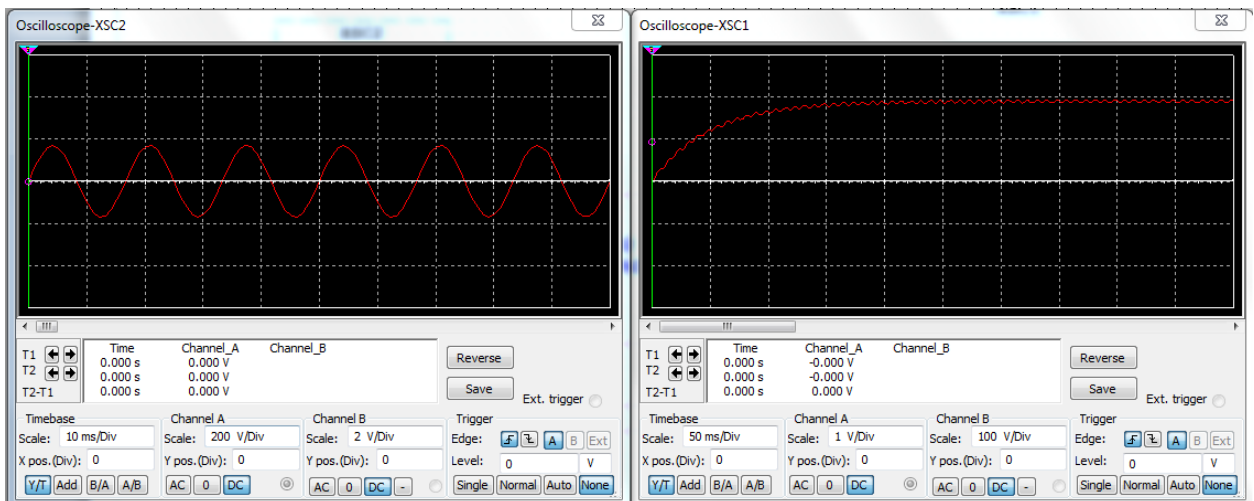

Figure: Full Wave Input waveform (left) and Smoothed Full Wave Rectified waveform (right)

Regulating

There are generally two basic types of ways to regulate a DC power supply. Linear and Switching are the two main ways to regulate power. This is the most complex part of the design because it controls most of what your output is going to be and how it's going to be used. There are key things to look at when choosing between the two. For example, when designing the power supply you have to choose its efficiency, size, weight, complexity, noise, heat dissipation, power factor, and much more.

Linear Regulated

The first type of regulator design we will discuss is the linear regulated design. In this design the output voltage is regulated by dissipating the unwanted power in the form of heat. This is done by usually a resistor or a passing transistor in the active mode. The size and weight of a linear regulated power supply is generally heavier and bigger than switching regulated power supplies due to usually more heatsinks because of the heat variable. The linear regulated power supply has less parts usually also compared to the switching regulated power supply. Linear power supplies have a high level of performance. They get their name from the obvious reason that they use linear techniques to regulate the output. Linear power supplies are mostly used when noise is an important part of what is being supplied. For example, if audio electronics are being used we would want to use a linear power supply because audio components work best when noise is minimized to achieve the best performance. Explaining how a linear regulated power supply is simpler than designing it but the first thing that usually occurs is the output voltage after the smoothing process compares to a reference voltage. The difference of the two is then fed to a transistor which allows more or less current through. A MOSFET type transistor is usually used for this design and functions in a linear region. The problem with the linear power supply is the size, weight, and efficiency. The size is needed due to its low frequency and its efficiency is lower because it is dissipating heat which is wasted power.

Switching Regulated

The second method of regulated output is by using a switching power supply. The switching regulated power supply has a much higher frequency thus the transformer size and weight decreases. The switching regulator is generally usually off or on. The transistor has a small voltage drop across it thus less power is being wasted. When it is off then no power is being wasted. Another benefit of the switching regulator is that because the frequency is higher we can then reduce the smoothing capacitor. Most switching regulated components range from 50 kHz to around 1 MHz. Another advantage of using a switching regulated power supply is that the switching can be regulated with a feedback circuit that turns the MOSFET transistor on and off. There are disadvantage of using a switching regulated power supply also though. Due to the high frequencies this means there is a higher level of noise or electromagnetic interference (EMI). Also, since the switching regulator needs current to run, the power supply has trouble running at low voltages and often has a minimum output voltage requirement.

Specification	Linear Regulated	Switching Regulated
Size and Weight	Heavier Due to Transformer size and heat sinks.	Lighter weight and fewer parts.

Efficiency, Heat , Power dissipation	Low Efficiency (30-40% avg), dissipates larger amount of heat, wastes power in form of heat.	High efficiency (75% avg), transistor is on or off reducing wasted power.
Complexity	More Complex and more parts.	Less complex and less parts.
EMI Interference	Low noise and EMC interference due to less frequency.	Higher frequency results in more noise.
Output Voltage	Cost goes up for more power	Cannot supply a low voltage, costs much less to increase power.
Output Current	Can produce a low amount.	Must supply minimum current.

Parts and Design:

Transformer

When building a linear regulated power supply first we need to lower the AC voltage. The first part of the Power supply to obtain is the transformer. We first looked at the PLATT TR40VA001 turning 120 VAC into 24 VAC. the TR100VA001 from PLATT which is basically the same as the previous transformer but has a built in circuit breaker which protects the transformer from damage created by a fault, overload, or short circuit. The only downside to the TR100VA001 (4.06 lbs.) transformer is that it weighs twice as much as the TR40VA001 (2.02 lbs.) and costs twice as much also. But I noticed a problem in this transformer is that it had a low volt-ampere (VA) rating and decided it didn't satisfy the current rating we wanted. So we kept looking and found the 167P16-ND made by Hammond Manufacturing and sold by digikey. Having the power supply supply two different voltages we need a higher output current making selecting a transformer harder. This transformer takes the outlet input and lowers it to an output of 16 VAC and a maximum output of 5 Amps. The termination style of the transformer is wire leads making it easy to solder onto.

Rectifier

The next step is to convert the AC voltage into a DC voltage. To do so we look at the next component that is the full wave bridge rectifier. We looked at two different rectifiers both being a full wave rectifier consisting of four diodes. The first rectifier

looked at is the Mouser 625-KBL005-E4 which has a maximum peak voltage of 50 volts and amperage of 4 amps. The second rectifier looked at is the MCM electronics 135-GBPC3504 which has a higher peak voltage of 400 volts and maximum amperage of 35 amps. The 135-GBPC3504 was chosen for this design due to the higher range of voltage accepted. This rectifier also has a flat bottom and easy to solder terminals making it easy to wire. The 625-KBL005-E4 rectifier is commonly used for printed circuit boards which is not what is being designed thus is less ideal for our power supply.

Smoothing Capacitor

The step after rectifying the AC voltage into DC voltage is to smooth the circuit and minimize the noise. To do so we add a capacitor to the circuit in parallel to the regulators. The smoothing capacitor is given to us by the reference in the data sheet for the regulators we are using. The capacitor is a simple component and we only need to know the value for it to decide on which one to buy. According to the two data sheets the capacitor needs to be a 10 μ F capacitor. We found a 10 μ F capacitor COM-00523 on sparkfun's website also sold at digikey under the part number P975-ND. Since our voltage from the transformer is 16 V this one worked perfectly having a maximum voltage input of 25 V.

Regulators

Now that we have our capacitor we can start to regulate the two outputs we need. We need to supply two microcontroller launchpads and a motor with power. The requirement of the Arduino board is 12 volts and has a small current input. The motor also has a max input of 12 volts and a maximum current load input of 1.8 amps. The tivaC microcontroller Launchpad requires a 5 volt input. Thus we can design two outputs from the power source to supply a 12 volt output and a 5 volt output also. To obtain a 12 volt and 5 volt we must use two different voltage regulators. To obtain the first output of 12 volts we must take into account the output current capabilities also. The regulator must be able to handle enough current coming drawn from the board and motor. To keep it safe we looked for a 3 amp max regulator to handle more than enough current. The first one we looked at was the MC78T12CT made by Fairchild Semiconductor. It has a maximum voltage of 12 volts and 3 amps as required. It is also a fixed output so it cannot be adjusted. The part that threw us off was that on the mouser website it said it required a minimum input voltage which is unusually high. Usually there is a maximum voltage for the regulator and a minimum but this one had no maximum voltage given. Of course if voltages lower than the output desired is given then the output will be lower than the desired amount but in our case we are supplying more than the output and will be less than the maximum output voltage. So after looking more we found the LM1085 series from National Semiconductor. This series includes adjustable and fixed voltages of 3.3, 5.0, and 12.0 volts. Thus working perfectly for our design in case in the testing phase we need to increase or

decrease the voltage. This is done with two resistors and equation as shown below:

$$V_{out} = V_{ref} \left(1 + \frac{R_2}{R_1} \right)$$

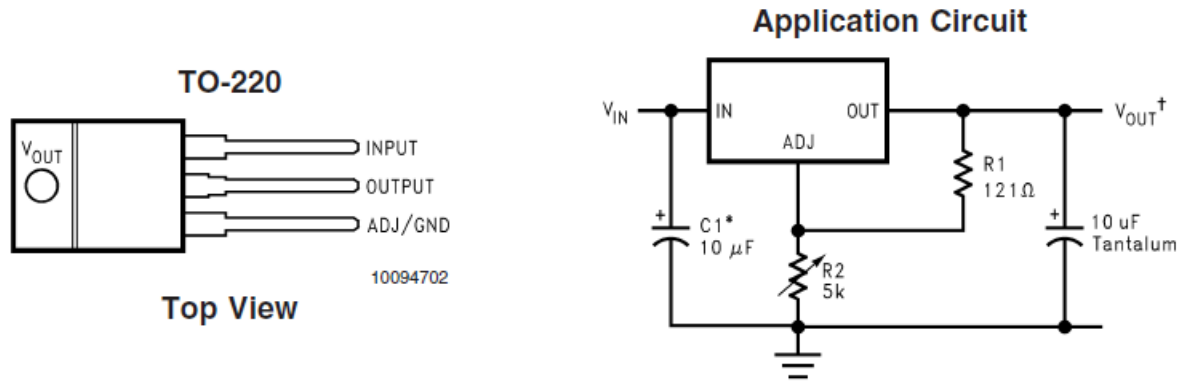

Figure: Permission to use still pending by Texas Instruments

The first regulator we need is the 12 volt and 3 amp regulator and we use the LM1085IT-12/NOPB made by Texas Instruments for this. It has a maximum Input voltage of 18 volts which is higher than the 16 volts supplied by the transformer. It has three pins that are for input (IN), output (OUT) and ground (GND or ADJ if adjustable). The minimum input voltage is 2.6 volts which is lower than we are supplying also. The second regulator we need is the 5 volt 3 amp regulator and we use the LM1085IT-5.0/NOPB made also by Texas Instruments. It has a maximum output of the desired 5 volts and 3 amps. The maximum input voltage is different from the previous regulator rated at 25 volts for the 5 volt regulator. The minimum voltage however is the same rating at 2.6 volts. We use two fixed regulators for now because the components we are supplying have specified input voltages of the desired output voltages. Sometimes after the voltage regulator there can be noise generated so we add another 10μF capacitor (COM-00523) to the circuit to clean it.

6.8 Smartphone App

For the smartphone application of the project, the group will be making a standard Android application using the Android API. To create this Android Application, the Android Studios IDE will be used for development.

Figure 6.8.1

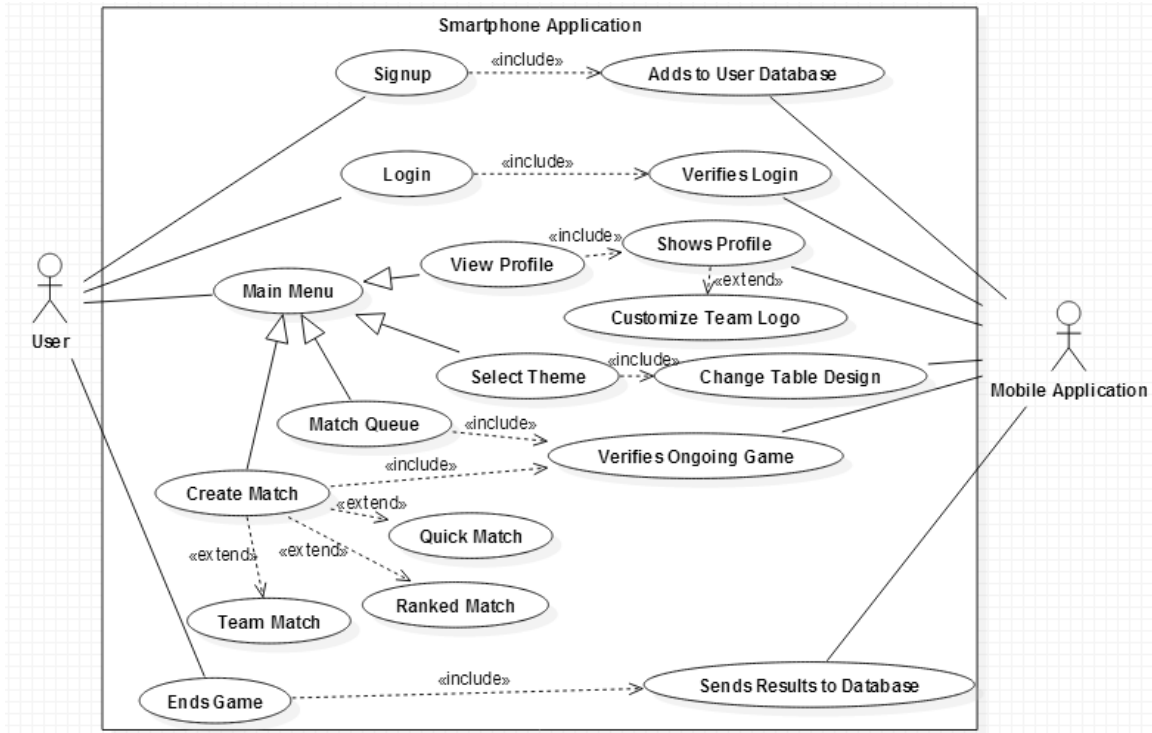

Use Case Diagram Shows the user interaction with the mobile application

This smartphone application will be the major component of the user interface features for the table. The features the application will have includes a sign up and login interface that will save the user information to a MySQL database. The app will then have a main menu screen. From this screen the user can see options such as viewing their own profile, queuing for a match, create a match, and create a team. In the profile screen the user will be able to view their rank, level and match history all of which are saved into a database. The user will also see a list of teams that they are currently apart of. For the queuing of the match on the smartphone, the user will be put into a queue that is in order of the time accessed to get into a match. Once a user queues for a match, the app will show who is currently playing on the table and the match score. This screen will also show the order of the people who queued in to play a match in a table below the current game statistics.

The other option from the main menu screen would be to create a match. The options for the match creation would be to create a team match, quick match, or ranked match. A quick match and ranked match only differs is how the players' statistics are affected. For a quick match both users would get points for their levels, with the winner getting more points than the loser. While ranked matches will affect user's rank, with the loser losing some points and the winner acquiring points to reach the next rank. The team match option allows users' to team up as teams of two. This type of match will just affect the team statistics such as team level and rank. Both of these statistics are affected in the same way the statistics for the quick and ranked match are in that level will always rise, more if you win

and less if you lose, and rank can go up and down depending on if the team wins or loses.

The final aspect of the application would be the team creation component. In this section, the users are given a choice to either join an already existing team or create an entirely new team. If the User wants to join an existing team, the user will be given a search bar to search for the team name. That search would look through a database that has all the teams in it. If the team is found, a request is sent to the team leader to join, but if the team is not found then the user is told that the group does not exist. When a user wants to create a team, the user will be given an inquiry as to what the team name is and which users do they want to invite to the team. Once that is completed, the user will be given a smaller version of a small section of the LED table display. With this section the user would be able to create a team logo.

6.9 Desktop App

The desktop application will create consists of a web page, databases, and applet. To create this web page the project group has decided to use PHP. Specifically a framework called Laravel. The website will include a MySQL database in order to store various information such as the match history, and the leaderboard.

Web Page and Database

Figure 6.9.1

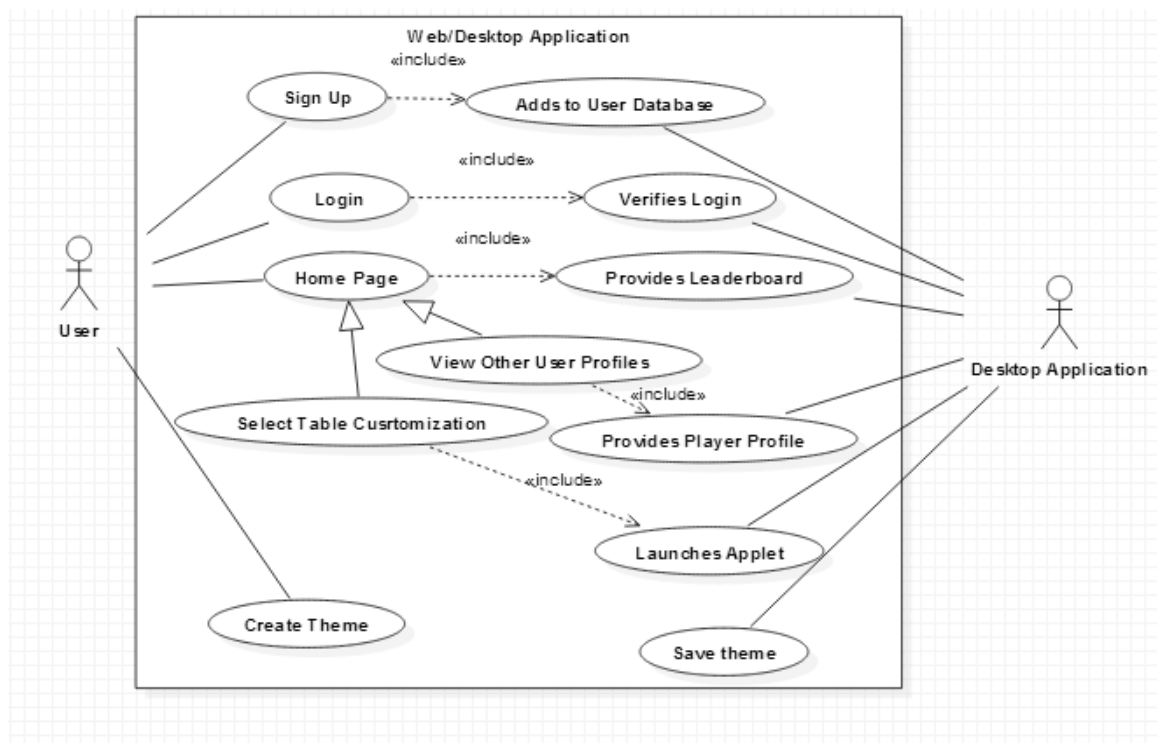

Use Case Diagram Shows the user interaction with the web application.

The project's web page components will consist of resources like a table theme creation applet, a player's profile, and a leader board. On the page there will be a user login bar. There will also be a link to the applet on the home page. The player profile page will show various info about the player. Some of the information displayed would be the player name, rank and level. Player level does not have a set level cap and player rank can be anywhere from zero to ten. Player level is determined by whether the user wins or loses the game. If the user wins the game, they will get 100 points while the loser will only get 50. In order to level up, the user would only need 100 points for each level. To determine the rank, an equation, shown in Figure 6.9.2a, was created by the group to handle it.

Figure 6.9.2a

	Win(Points Earned)	Lose(Points Lost)
Ranking	$50 + 0.10(\text{loser points})$	$-30 - 0.10(3000 - \text{winner Points})$

Figure 6.9.2b

Points For Rank	Rank Number
2701 - 3000	10
2401 - 2700	9
2101 - 2400	8
1801 - 2100	7
1501 - 1800	6
1201 - 1500	5
901 - 1200	4
601 - 900	3
301 - 600	2
0 - 300	1

Figure 6.9.2a shows the equation used to calculate the rankings while Figure 6.9.2b shows the level breakdown of the rankings.

Beside the rank and level, the profile will also show the user's name, nickname, which teams the player is on, and the player's match history. The list of the teams on the user's profile page will be handles by a database. On this database, the different columns will represent the team name, team member count, the team level, and the team rank while each row will represent a different team. The match history will also be represented by a database. This database's different columns will represent the different information such as the date, result, match length, rank, resulting match points, who the opponent was, and what team if any were you on.

On the main page besides the player information, the webpage will also display a leader board that shows the statics of all users that are registered in the project's database. This leaderboard will show things like the player's rank, nickname, amount of games played, and a link to their profile page. This profile link will display all the components of a player's profile page that was previously stated.

Applet

In this applet you will be able to create various animations that fit different situations and group them together in order to form one theme. A theme would consist of four animation states which are a match start animation, a cup removal animation, an idle animation, and a match over animation. The applet will allow the users to freely create an animation on the LED table using each LED available. So, each user can set the color of any individual LED or groups of LEDs to any color that the user desires. The user will also be allowed to implement various effects on the table, such as static, dynamic or ripple. The static effect will maintain the same color of the table, dynamic will continuously change the colors of the LED on the table, while ripple will cause a wave that starts at the point the ping pong ball hits the table. When playing team matches, the option to have the logo to be displayed on part of the table is there. So the user would create various animations in the theme this way. Whatever animation the user created for the match start algorithm will be what the table will look like as the game is about to start. The idle animation will be an animation or animation set that will be shown as the game is played. The cup removal animation will occur when a player or team scores and the cup is then removed from the table. All of these animations will be saved as one theme that would then be saved to that player's account. These saved themes will be able to be accessed by the user via the smartphone app. From the app, the table's theme can be set.

7.0 Prototype Testing

7.2.5 Ball Cleaner

When testing the ball washer we have two components to control, the fan and the sensor. Adjusting the power to the motor to allow the ball to hover right at the top

of the piping is one part to be tested. If the fan is too strong then we must reduce the voltage or if the fan is too weak we must increase the voltage. Also when testing the IR sensor we must use the software to detect if they are working and sensing the passing of the ball which will most likely include trial and error. If the sensors are not drawing enough current then a resistor must be added in parallel to help draw more current to the sensors.

7.2.6 Power Supply

Testing the power supply can be a very dangerous and life threatening process. Handling AC current from an outlet can cause pain and injury by touching the hot wires in the circuit. To test the outputs and current we can multisim or eagle to run the electrical schematic on its software. To do so we input the basic parts of the electrical schematic and customize them to their rated values and desired outputs. Then we attach a load for each regulator to draw a current and measure the voltage and current. Also testing the power supply with loads in reality will have to attach loads to each and regulator and measure the output with a multi-meter. If parts need to be replaced or something blows we can use formulas or higher rated input components to test what went wrong.

8.0 Administrative Content

8.2 Labor Division

The team set out milestones and labor division for Senior Design 1 and 2 which are shown in the figure shown below. Basically, as the figure represents. The division of labor was divided as evenly as possible. Each member has a responsibility for a single or more than one major component of the project. Edgar Alastre along with Ashish Naik is in charge of the hardware. In detail, the two aforementioned team members are in charge of everything that involves the MCU, Circuitry, RGB LED array design, and impact sensor design as well as providing an initial and more basic programming of the MCU with all of its sensors. However, the entire team is in charge of the assembly of such parts as the amount of soldering and wiring is so extensive it is more beneficial for the team to assemble the high amount of wiring and soldering together so that the team can proceed to the next phase. Jonathan, on the other hand will be in charge of the Smartphone App as well as the desktop App. This involves setting the entire framework that will power the software-heavy side of the project, since this phase could result overwhelming for a single member of the team he is to be required to have a constant feedback as the other members of the team, especially Edgar Alastre has moderate knowledge in the technologies behind all of the software involved. The last member, Colton, will work on the development of the ball cleaner and power supply. Since the ball cleaner does not require to communicate with the other subsystems, Colton will also have to choose his own MCU to power the aforementioned subsystem, however, since Edgar has the required knowledge to provide with a PCB and schematic design of Colton's part, Edgar will provide assistance to Colton as he will require it.

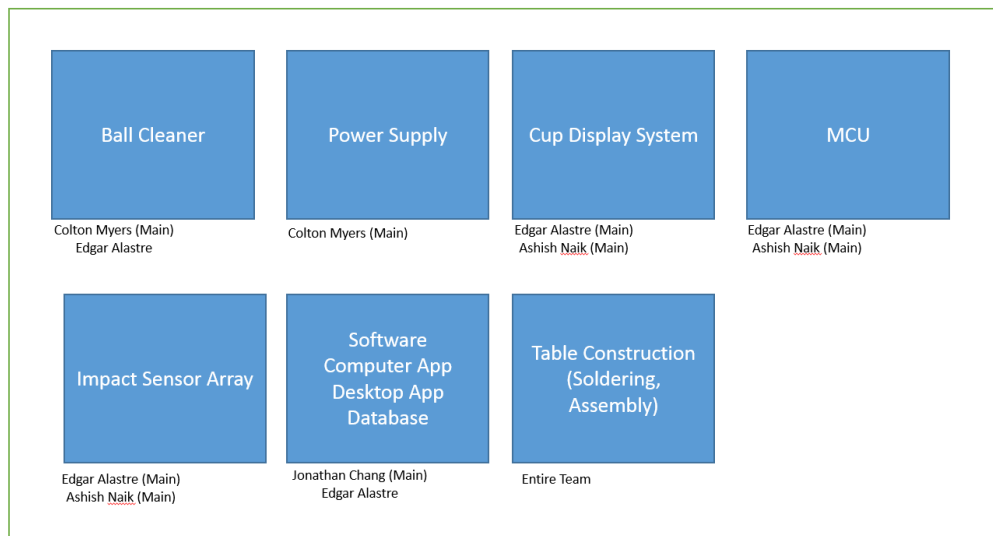

Figure x.xx: Table of Labor Distribution

Bibliography:

Relevant Technologies:

A Brief Introduction to the Serial Peripheral Interface (SPI). (2015). Retrieved August 5, 2015.

A Look at the Basics of Bluetooth Technology. (2015). Retrieved August 5, 2015.
DeMilo, C., & McDaniel, D. (2013). Truly round LED sources deliver optimal performance in many SSL applications (MAGAZINE). Retrieved August 3, 2015.

Harris, Tom, and Wesley Fenlon. "How Light Emitting Diodes Work" 31 January 2002. HowStuffWorks.com.
<<http://electronics.howstuffworks.com/led.htm>> 02 August 2015.

Holmes, D. G., & Lipo, T. A. (2003). *Pulse width modulation for power converters. [electronic resource] : principles and practice*. Hoboken, NJ : John Wiley, 2003.

Marian, P. (2010). Fairy Flashing LED Lights. Retrieved August 5, 2015, from <http://www.electroschematics.com/766/flashing-led-lights/>

Paul, R. P., Rathod, G. B., Trivedi, V. R., & Thakkar, P. V. (2013). Persistence of Vision Control Using Arduino. *International Journal Of Intelligent Systems & Applications*, 6(1), 102. doi:10.5815/ijisa.2014.01.11

Reiss, A. (2011, October 21). The Difference Between Single- and Tri-colored LEDs. Retrieved August 3, 2015.

Sellers, F. (2011, November 8). Back to LED Basics. Retrieved August 3, 2015.

Serial Communication using UART. (n.d).

SPI Interface in embedded systems. (2006). Retrieved August 5, 2015.

Spookyblue.com » How do flashing LEDs work? (2009, August 21). Retrieved August 5, 2015, from <http://spookyblue.com/spookyblog/how-do-flashing-leds-work>

Existing Similar Projects:

Braun, C., Hogan, R., Jackson, J., & Thomson, D. (n.d.). The DCPPTSS. Retrieved July 16, 2015, from http://www.eecs.ucf.edu/seniordesign/fa2011sp2012/g06/DCPPTSS/THE_DCPPTSS.html

Darrah, K. (2012, September 16). How to Control a Ton of RGB LEDs with Arduino & TLC5940. Retrieved July 24, 2015.

Phillips, Z. F., D'Ambrosio, M. V., Tian, L., Rulison, J. J., Patel, H. S., Sadras, N., & ... Waller, L. (2015). Multi-Contrast Imaging and Digital Refocusing on a Mobile Microscope with a Domed LED Array. *Plos ONE*, 10(5), 1-13. doi:10.1371/journal.pone.0124938

100Pixel RGB LED table - Interactive (touch). (2012, April 29). Retrieved July 24, 2015, from <http://www.it-gecko.de/100pixel-rgb-led-tisch-interaktiv-touch.html>

Components:

AT91SAM ARM-based Flash MCU SAM7S512 SAM7S256 SAM7S128 SAM7S64 SAM7S321 SAM7S32 SAM7S161 SAM7S16. (2012). San Jose, CA: Atmel Corporation.

Atmel ATmega640/V-1280/V-1281/V-2560/V-2561/V 8-bit Atmel Microcontroller with 16/ 32/64KB In-System Programmable Flash SUMMARY. (2014). San Jose, CA: Atmel Corporation.

Piezo Vibration Sensor - Small Vertical. (n.d.). Retrieved July 16, 2015, from <http://store.cutedigi.com/piezo-vibration-sensor-small-vertical/>

SAM3X / SAM3A Series Atmel | SMART ARM-based MCU DATASHEET. (2015). San Jose, CA: Atmel Corporation.

Tiva™ TM4C123GH6PM Microcontroller. (2007). Austin, TX: Texas Instruments Incorporated.

Research:

Rules - Drinking Beirut (Beer Pong). (n.d.). Retrieved July 24, 2015, from <http://www.beirut-guide.com/rules/basic.php>

Rules-Official Tournament Rules | BPONG. (n.d.). Retrieved July 24, 2015 from <http://www.bpong.com/tournament-rules/>

Rules-Typical House Rules | BPONG. (n.d.). Retrieved July 24, 2015, from <http://www.bpong.com/beer-pong-rules/>

Standards:

D2395 – 14 Standard Test Methods for Density and Specific Gravity (Relative Density) of Wood and Wood-Based Materials. (2015). In *Book of Standards* (Vol. 04.10). PA: Subcommittee D07.01 on Fundamental Test Methods and Properties.

D2633 - 13a Standard Test Methods for Thermoplastic Insulations and Jackets for Wire and Cable. (2015). In *Book of Standards* (Vol. 10.02). PA: Subcommittee D09.18 on Solid Insulations, Non-Metallic Shieldings and Coverings for Electrical and Telecommunication Wires and Cables.

D4442-07 Standard Test Methods for Direct Moisture Content Measurement of Wood and Wood-Base Materials. (2015). In *Book of Standards* (Vol. 04.10). PA: Subcommittee D07.01 on Fundamental Test Methods and Properties.

E2126-11 Standard Test Methods for Cyclic (Reversed) Load Test for Shear Resistance of Vertical Elements of the Later Force Resisting System for Buildings. (2015). In *Book of Standards* (Vol. 04.12). PA: Subcommittee E06.11 on Horizontal and Vertical Structures/Structural Performance of Completed Structures.

E564-06(2012) Standard Practice for Static Load Test for Shear Resistance of Framed Walls for Buildings. (2015). In *Book of Standards* (Vol. 04.11). PA: Subcommittee E06.11 on Horizontal and Vertical Structures/ Structural Performance of Completed Structures.