

C.L.A.I.M

Computerized Luggage and Information Messenger

(Group 10)

Ernest Jackman - Electrical Engineer
Adrian McGrath - Computer Engineer
Tomasz Pytel - Computer Engineer

Intro

-**Problem:** Baggage Claim is one of the most crowded and unmanaged processes in airline travel

-**Solution:** By attaching RFID tags to luggage, and scanning them when they are loaded onto the baggage carousel, passengers can be alerted that their bag is available on the carousel without them having to check every individual bag as it passes by

Goals/Objectives

- Group member had an existing patent on original idea for project
 - Experiment with “new” (to us) technology to create a solution
 - We want to make the luggage pickup easier for everyone
-
- Scan bags as they are loaded onto the carousel
 - Keep track of remaining bags on the carousel
 - Update display monitors in the baggage claim area
 - Notify passengers when their bag is available to be picked up

Design Overview - Single Level

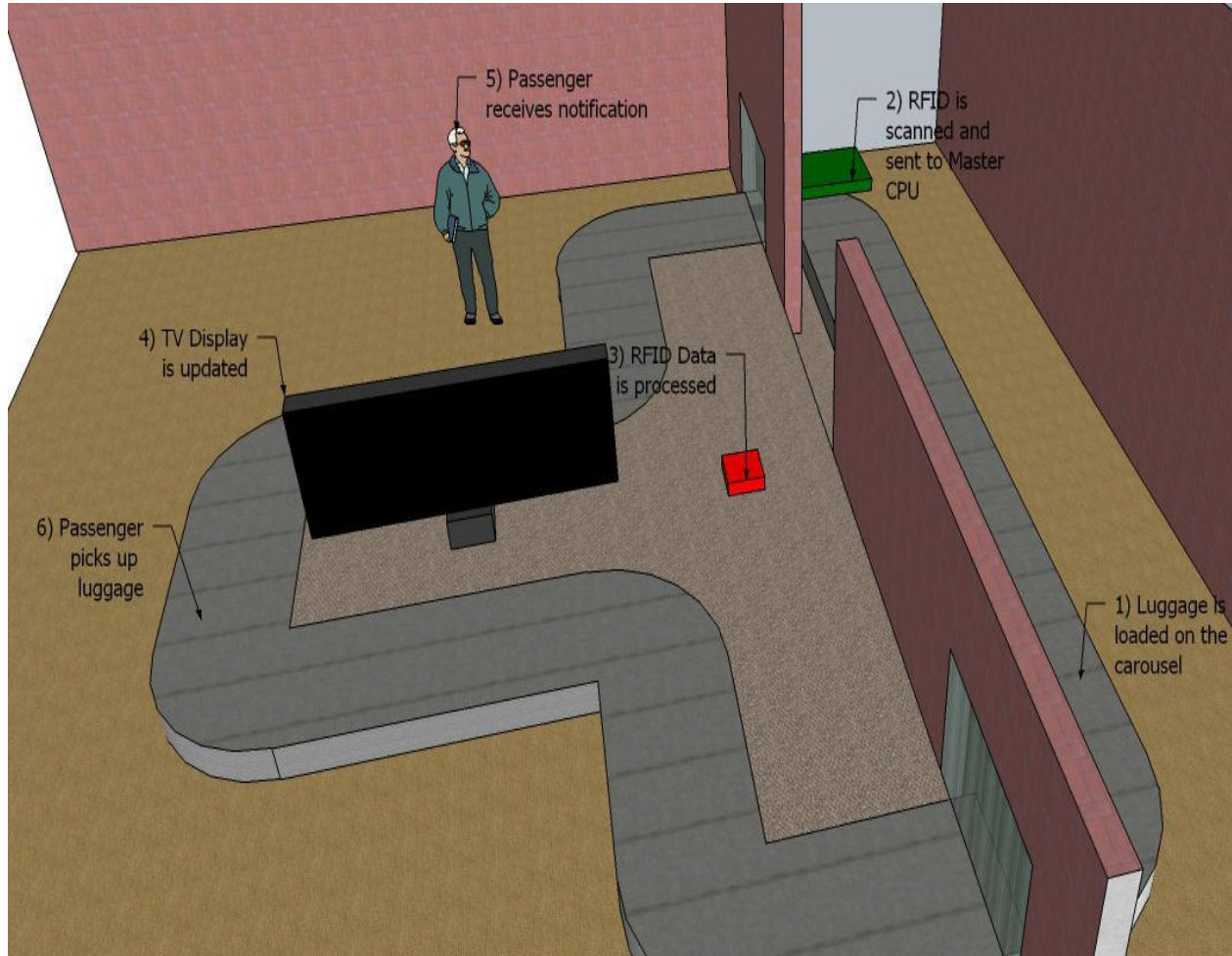

Design Overview - Multi Level

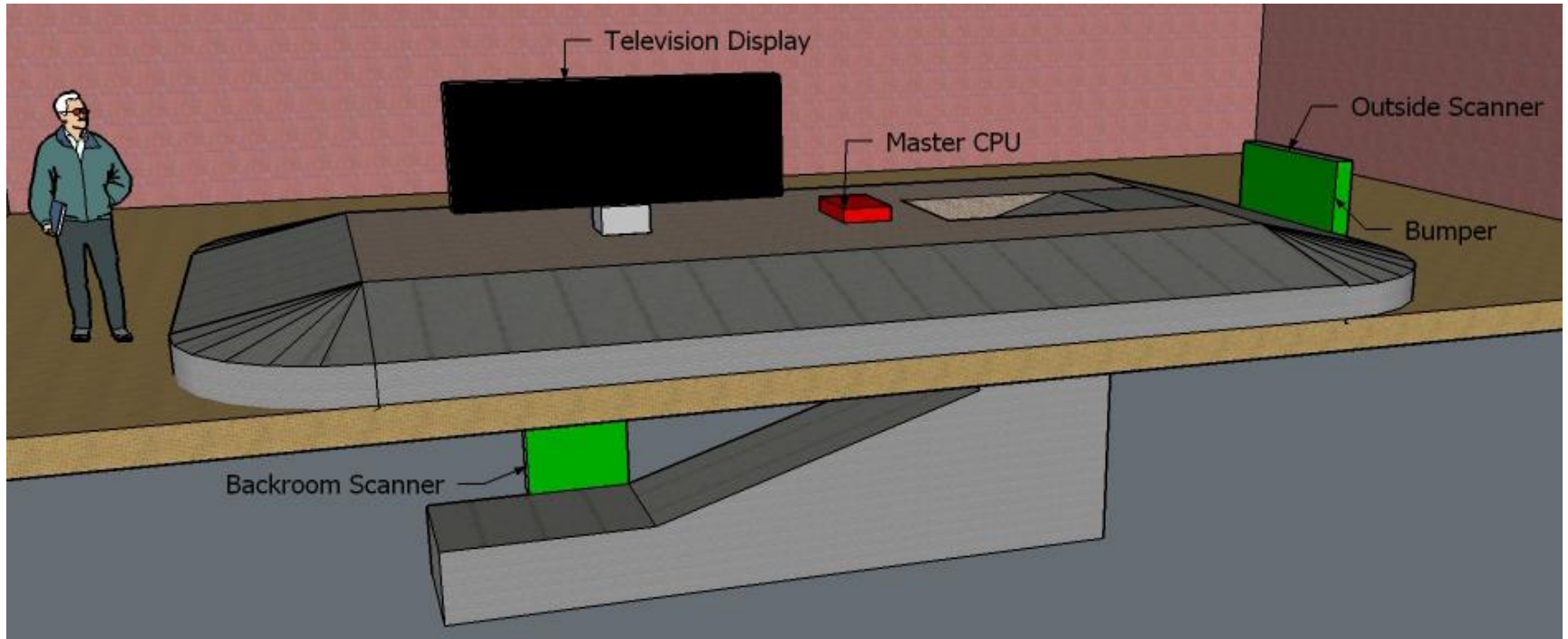

Design Overview - Mixed

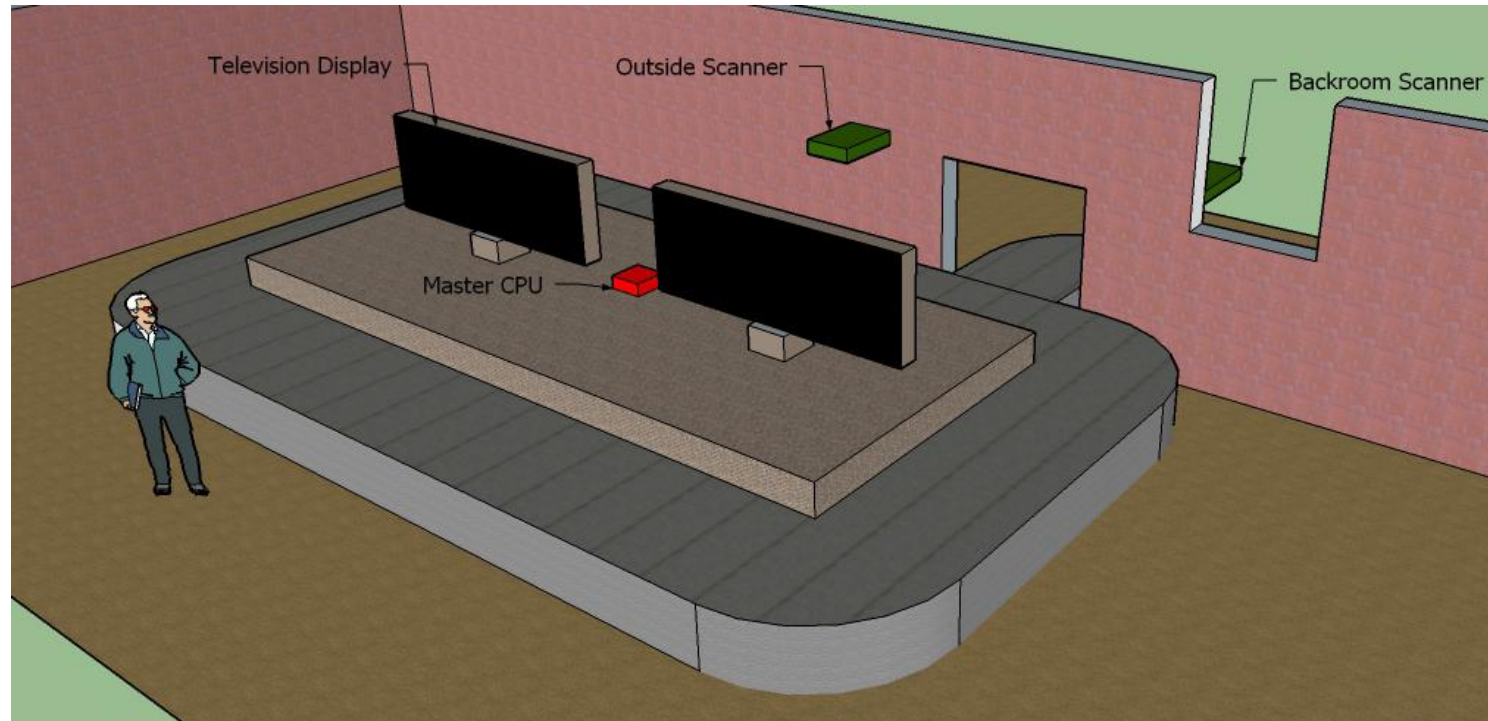

Requirements

- Tag scannable when placed anywhere on luggage
- Tag data scanned and transmitted accurately
- Able to manage tag data coming from more than one scanner at unknown intervals
- Communication with Airline services
- Owner notified with minimal delay
- List of bags currently on the carousel in the order in which they were scanned displayed on a monitor

Specifications

Description	Number	Units
Accurately scan RFID tags	95% of the time	
Notify recipient with a delay no greater than	60	seconds
Size requirements to allow for luggage clearance	Height: $25 < x < 30$	inches
Maximum system communication downtime	2	minutes
Scanning Rate based on carousel speed	500	milliseconds

Specifications

Description	Number	Notes
Input Voltage	2.7-5.5V	5V for TRF7970, 3.2V for MSP430 and LMX9838
RF output	100-200 mW 0.4-2.0 mW	Output of RFID scanner. Output of BlueTooth
Electric Field output	80.4dB uV/m @ 3m	FCC limit is 124 uV/m
Temperature Range	-40C - 85C	
Current	27mA-120mA	Scanning unit current draw, 215mA Rated Maximum
Raspberry Pi 2	4.8-5.2V 230-450mA	USB Voltage/Current
MK808b	4.8-5.2V 1-2A	

Standards

- Near Field Communication (NFC) Standards ISO/IEC 18092 and 21481
- Tag ISO 15693, 14443A/B and FeliCa
- ISO/IEC 18000-3
- Title 47 - Chapter I - Subchapter A - Part 15 - Subpart C - Intentional Radiators

System Block Diagram

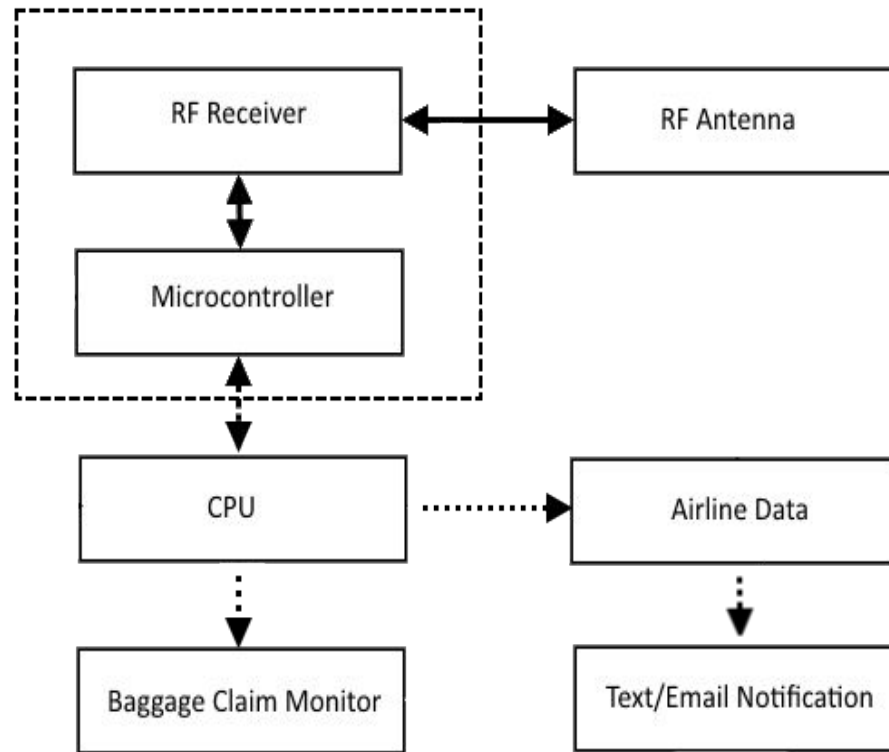

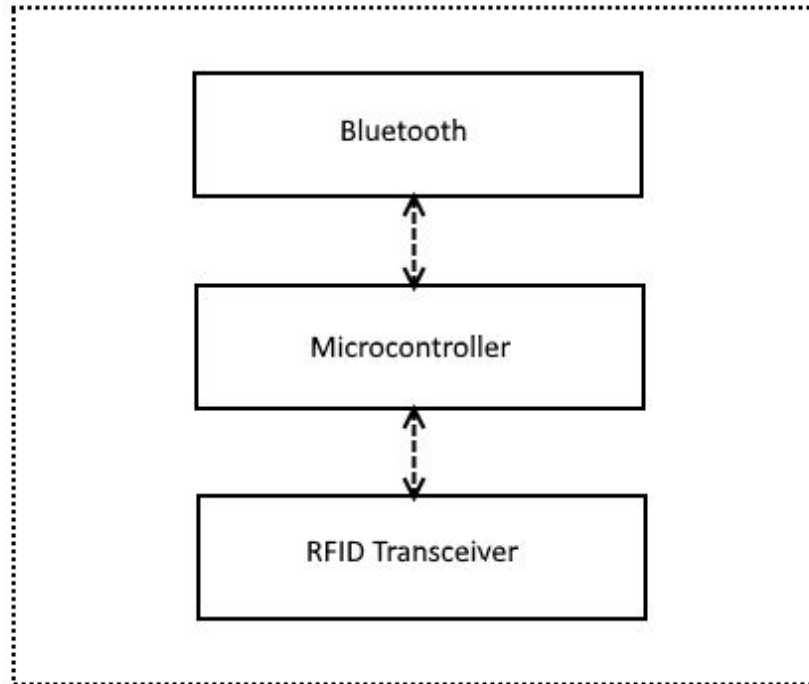

Original Plan

- Initial cost \$700 for first UHF unit.
 - This includes proprietary software
- Additional \$200 for UHF antenna
- Offers up to 3 to 9 meter scan range
- Increase power output up to 1.4 Watts
- Connection include UART serial communication or USB.



Cost: \$125



Cost: \$200

Current Hardware Design

- TRF7960 from Texas Instruments
 - Requires building modulation/demodulation circuit
 - Total cost of parts ~\$10
- HF antenna
- Offers up to 4 inches of scan range
- Connection includes Parallel and SPI

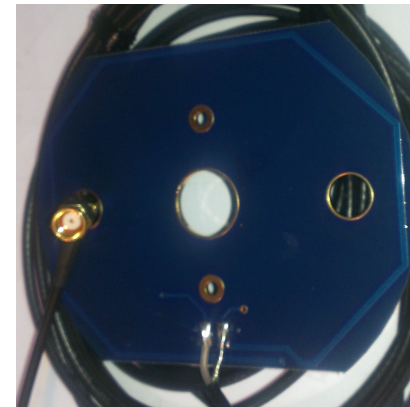
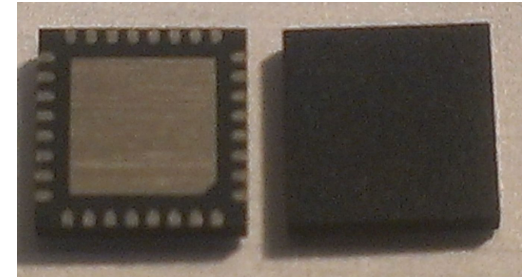

Cost: \$40

TRF7960a Transceiver

- Supports Near Field Communication (NFC) in the 13.56 Mhz range.
- Able to scan RFID tag protocol 15693,18000-3, 14443A/B, FeliCa
- Read/Write ability of Active and Passive Tags.
- SPI or Parallel Communication to MSP430



Cost: \$7

LMX9838 Bluetooth

- Bluetooth 2.0 Stack
- UART connection to MSP430
- All in one Plug-n-Play chip, defaulting to Transparent mode passing serial data on its UART line to any linked device



Cost: \$32

MSP430G2553

- G2553 offers a Universal Serial Communications Interface (USCI)
 - UART, SPI, and I2C connections
- MSP430 line of chips is supported and compatible with LMX and TRF chips since each chip is designed and referenced by Texas Instruments.



Cost \$3

TRF7960a - Schematic

- Excites and collects information from Tags using transceiver.
- Transmits data to MSP430 through the Serial Peripheral Interface.

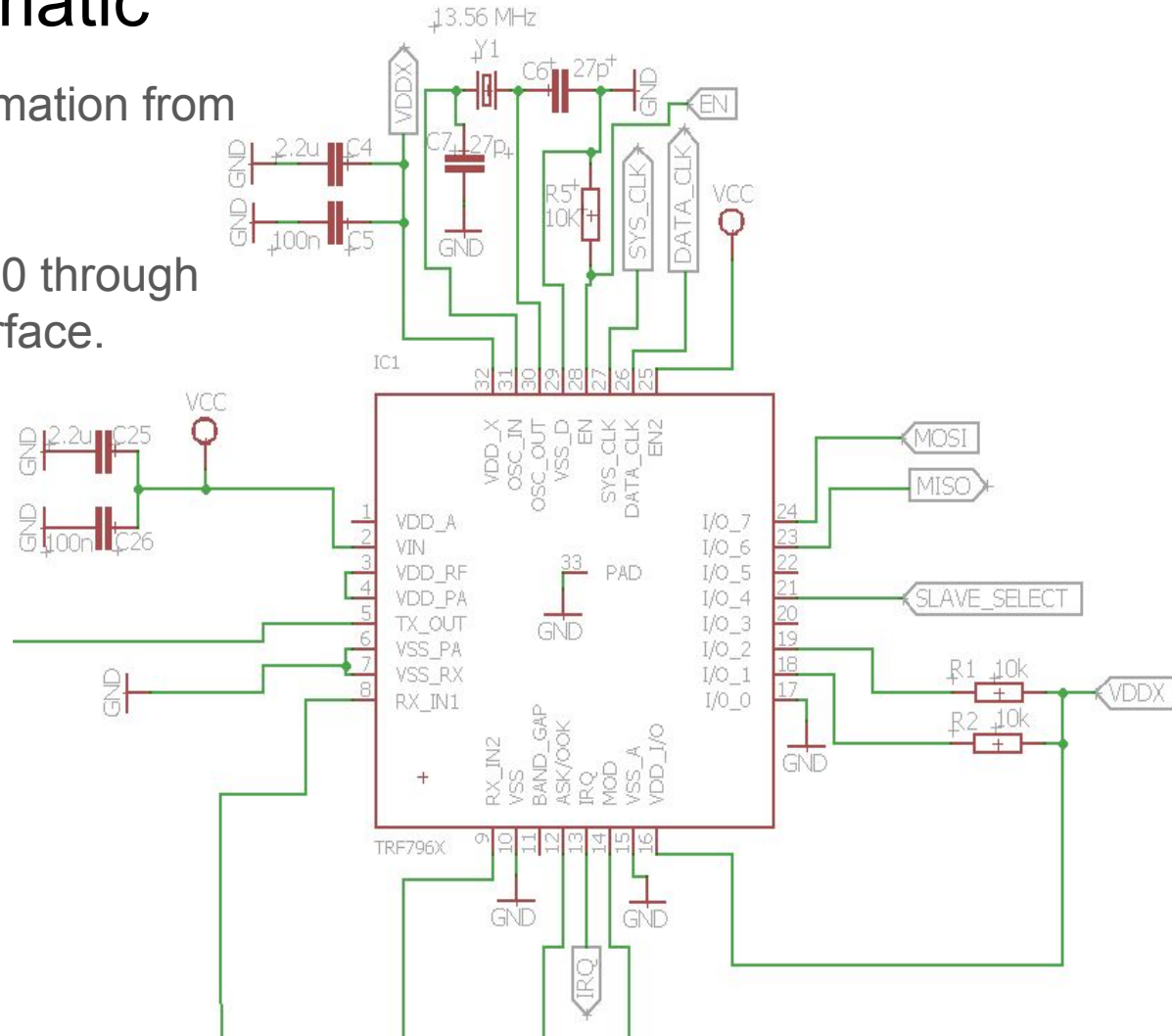

TRF7960a Transceiver

- The TRF7960 has one transmit path and two receiver paths.
- The main and auxiliary receiver input stages are RF envelope detectors
- The main receiver is used for reception, the auxiliary receiver is used for signal quality monitoring

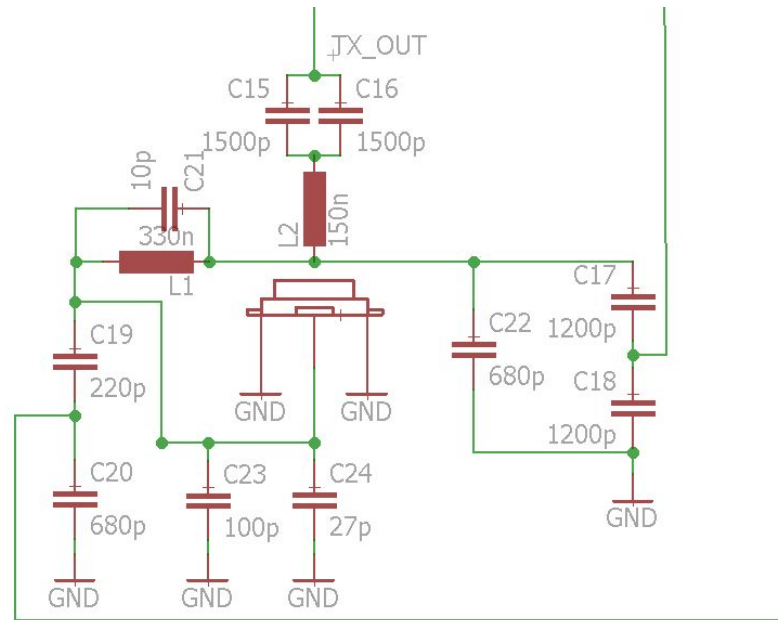

LMX9838 Bluetooth

- Bluetooth serial communication used to transmit collected Tag information to Pi Device.
- Communicated with MSP430 using UART
- Status LED indicate if a connection is made and data is being loaded into the device.

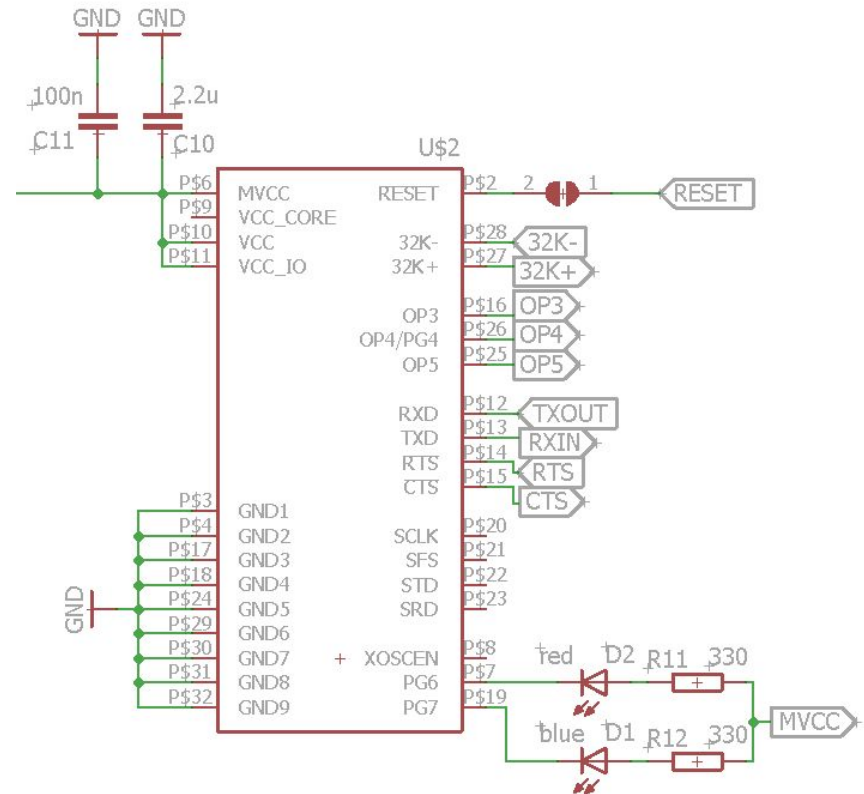

MSP430G2553

- MSP430 connect to both the LMX and TRF chips though serial communication.
- Initiates the operational setup and status flags for the LMX and TRF on boot
- Processes the tag information from the TRF and passes it to the Bluetooth
- A status LED is used for troubleshooting or tag indication

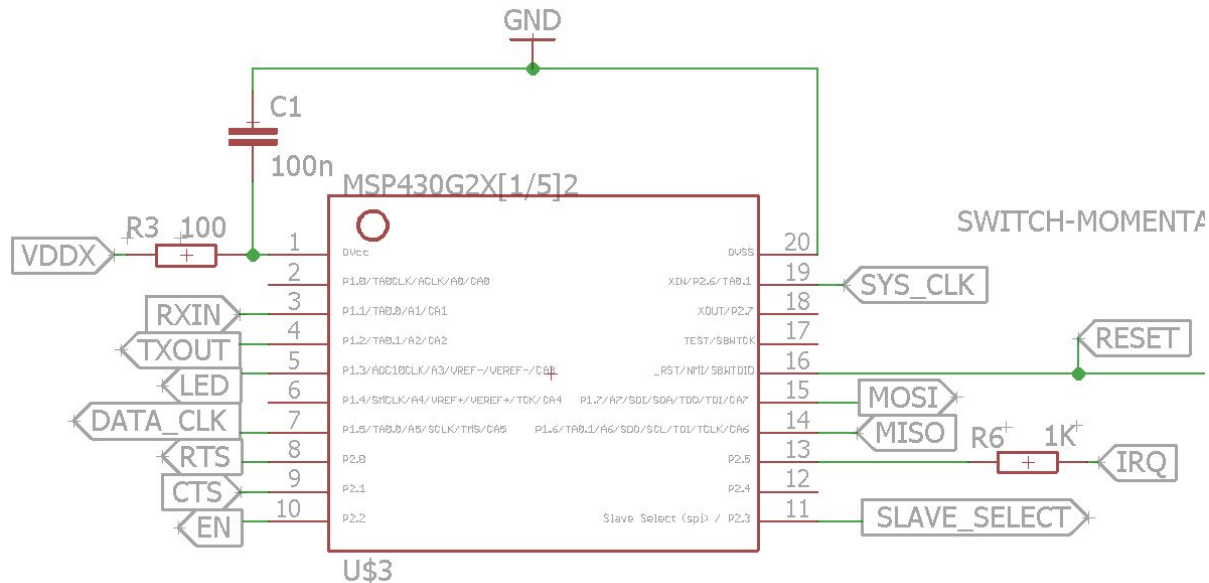

Power Supply

-Power Regulation is being handled by regulator chips.

- The Source 5V needed for operation is being supplied by a 12V AC-DC wall plug, regulated through a (35V-5V) regulator
- The TRF scanner is operated on the 5V line directly, and has an internal regulator that converts down the voltage for the use by the MSP430
- The LMX chip uses a (5V-3.3V) regulator to power the Bluetooth separately due to current limitation of the TRF internal regulator

C.L.A.I.M. Scanning Unit PCB

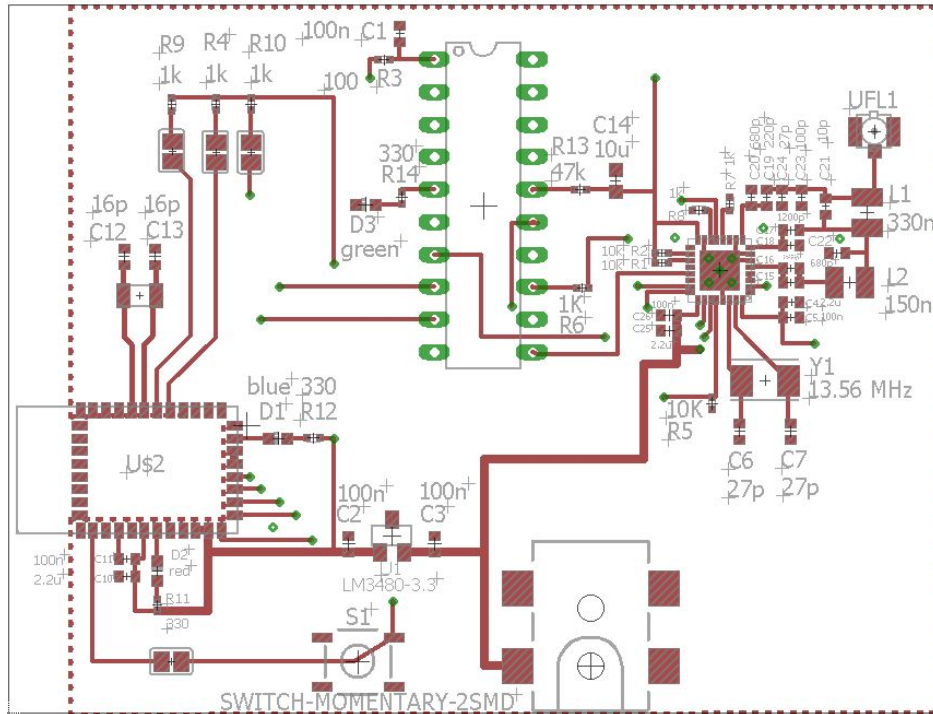

C.L.A.I.M. Scanning Unit

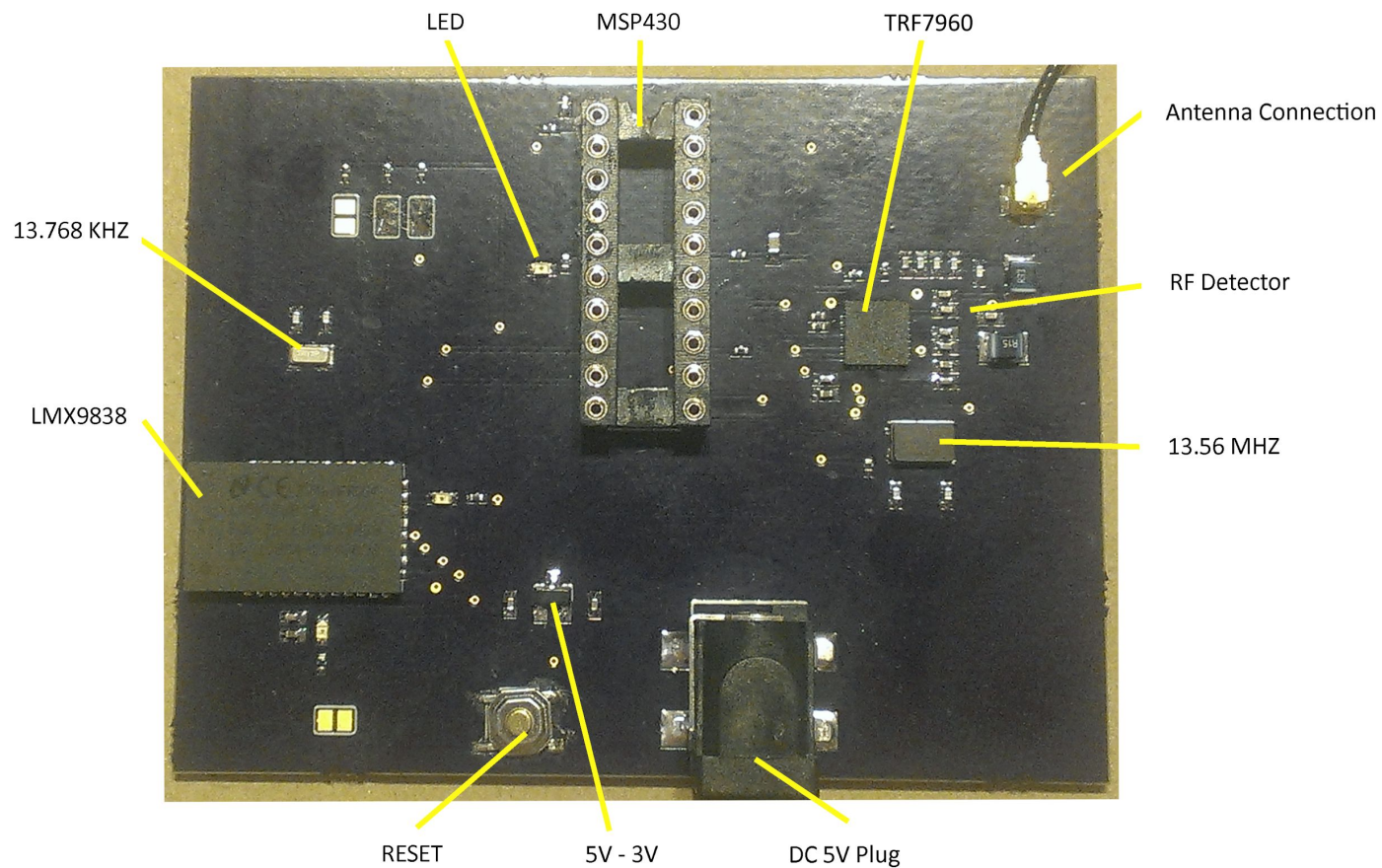

Microcontroller/ RF Scanner - Software

Eagle



Code Composer Studio 6



Microcontroller/ RF Scanner - Software



Master CPU - Hardware

Raspberry Pi 2 Model B

Cost: \$43

CPU: 900 MHz quad-core

SDRAM: 1 GB

USB Ports: 4

Storage: MicroSD

Network: 10/100 Mbit/s Ethernet

GPIO: 17 pins

Power: 800 mA (4 W)

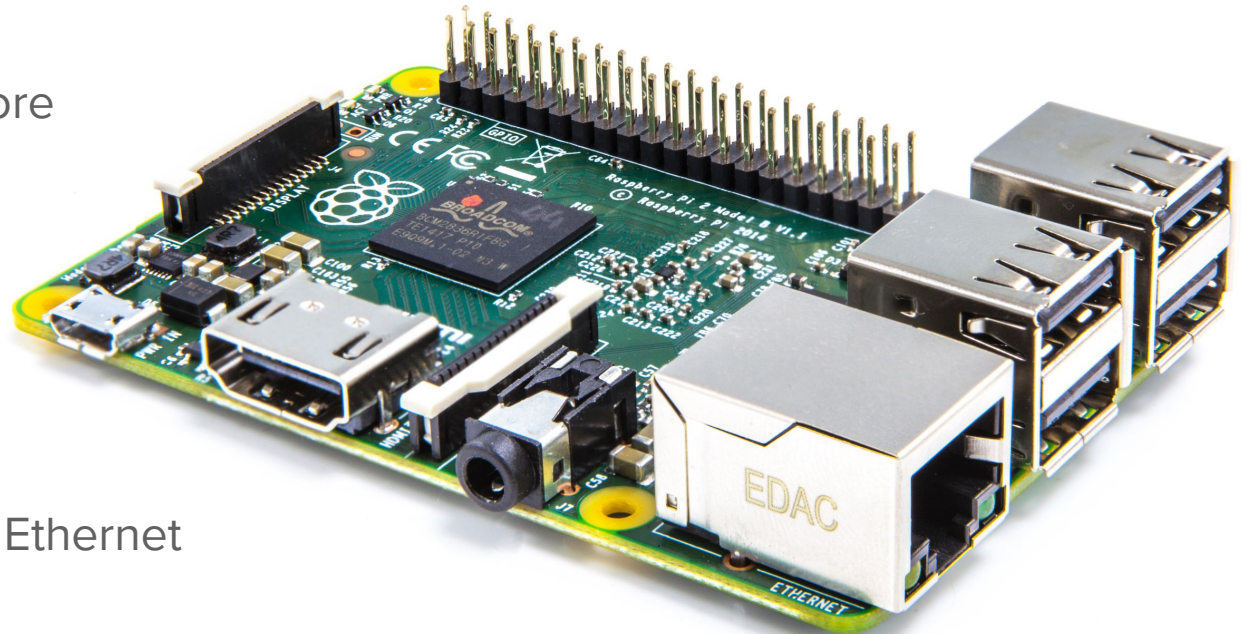

Master CPU - Additional Hardware

Edimax EW-7811Un Wi-Fi USB Adapter

Cost: \$9

Wireless 802.11b/g/n standards

Data rate up to 150Mbps

Raspberry Pi 2 Recommendation



TRENDnet Micro-Bluetooth USB 3.0 Adapter

Cost: \$12

Meter Range

compatible with previous versions

100

Backwards



Master CPU - Software

Language: Java SE 8

IDE: Eclipse



eclipse

Master CPU - Requirements

- Must be able to receive data from at most two scanning units via a bluetooth connection
- Must be able to send data to multiple display devices via a bluetooth connection
- Must be able to communicate with an airline's passenger notification webservice via an internet connection
- Must be able to process and temporarily cache baggage data
- Must be able to send start/stop commands to the scanning units and the display devices
- Baggage data processing and management must not prevent the bluetooth communications

Master CPU - Thread Design Overview

- Multi-threaded design to allow for maximum bluetooth availability
- Threads alive on a strictly as-needed basis

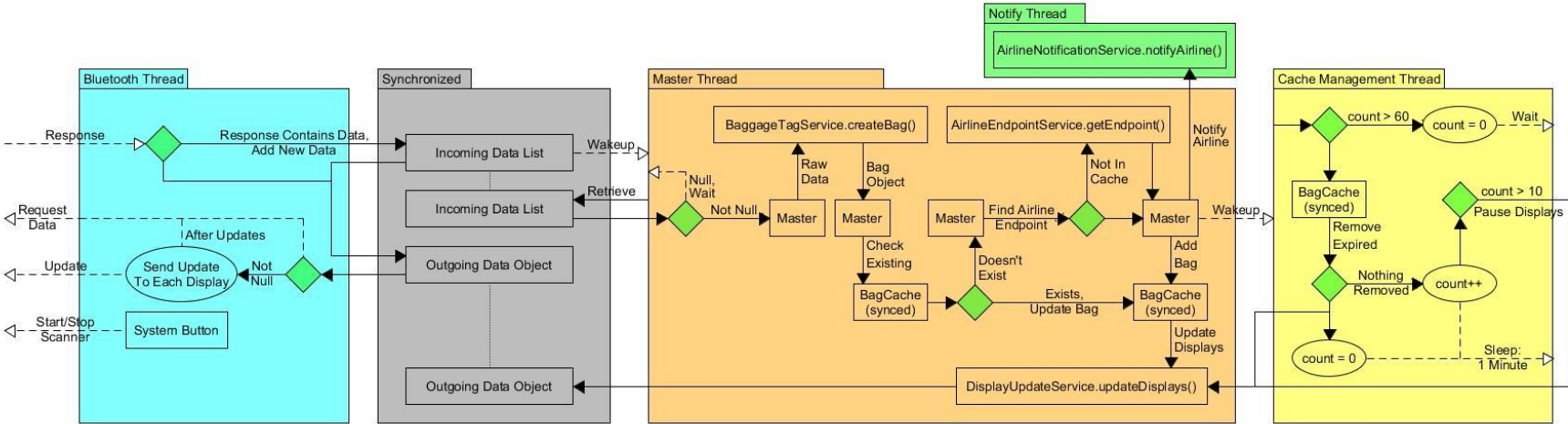

Master CPU - Bluetooth Thread

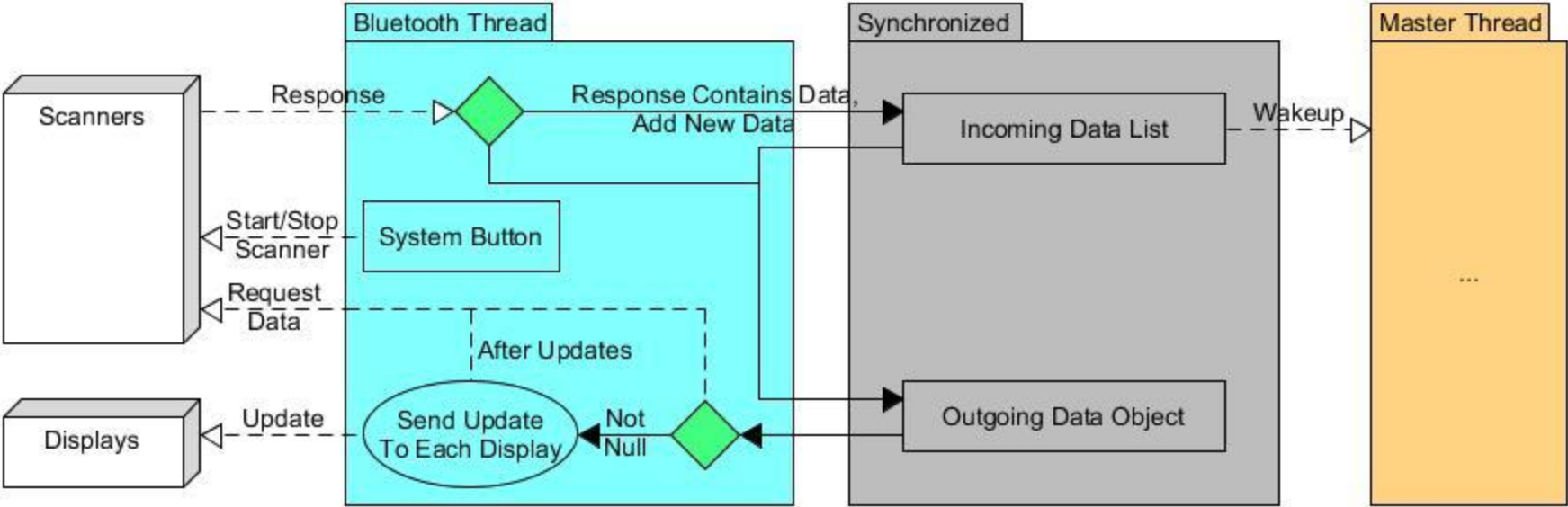

Master CPU - Master Thread

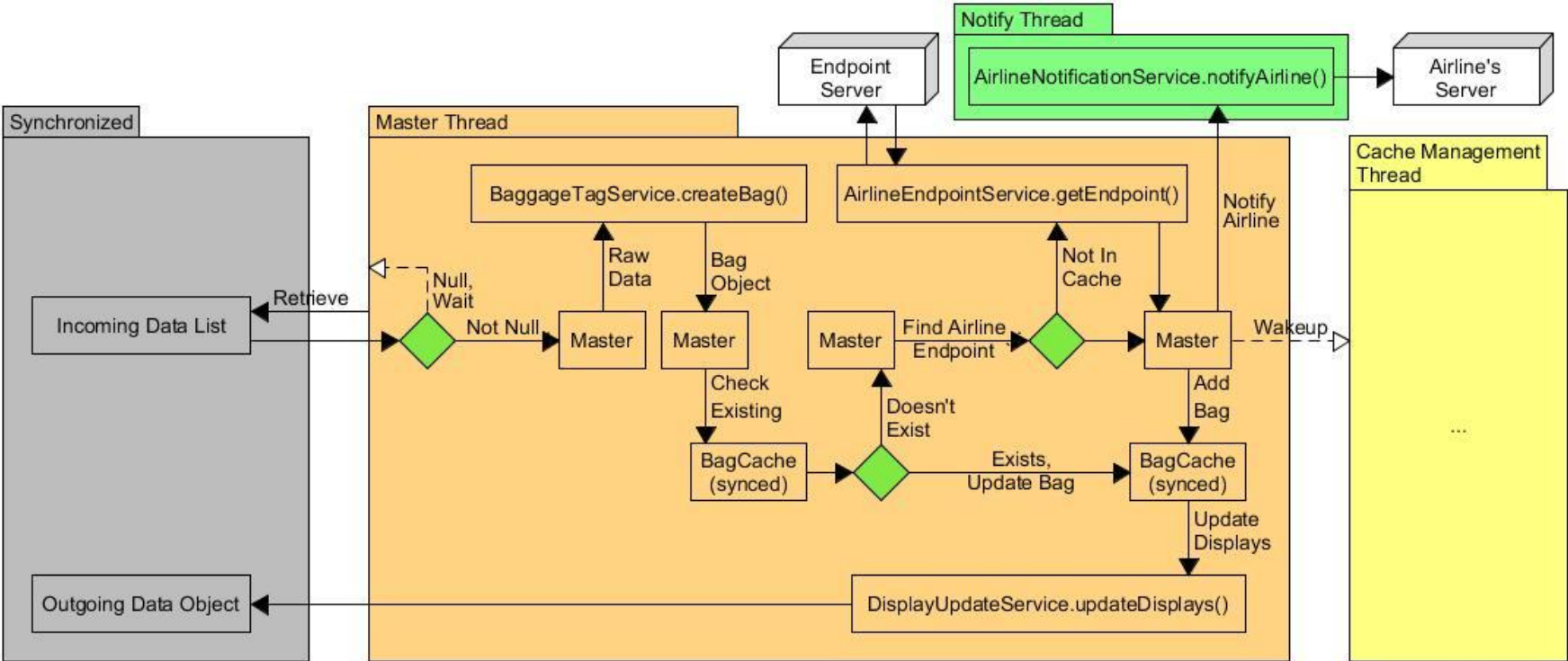

Master CPU - Cache Management Thread

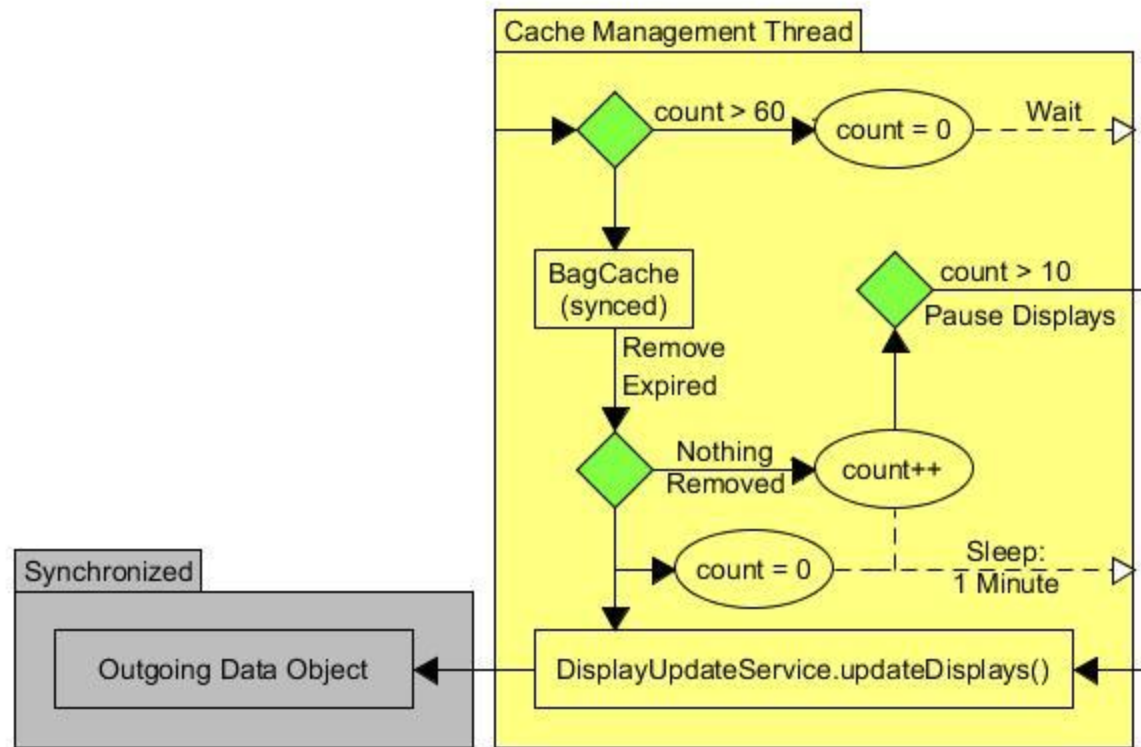

Android Stick - Hardware



MK808B Plus
(\$28.99 via Amazon)

Model	MK808B	Google Chromecast	Measy U4C
System	Android 4.4	Android 4.1	Android 4.2
Connectivity	Wi-Fi Bluetooth 4.0	Wi-Fi Bluetooth 4.0	Wi-Fi Bluetooth 4.0
Features	Double-sized Radiator	Ultrasonic Networking	Webcam Microphone
Price	\$28.99	\$35.00	\$79.99

Android Stick - Hardware

-Why MK808B Plus?

- Met connectivity and system requirements
- Least expensive option
- Most commonly used

-Standards

- IEEE 802.11
- IEEE 802.15.1

Android Stick - Software

-Dev Software used: Android Studio

-Language: Java



Android Stick - Requirements

Must be able to:

- Receive data from Master CPU via a Bluetooth connection
- Parse the data received
- Update cache with new information
- Display the information on the TV screen

Android Stick - Software

-Two Modes

- Display - Displays tag information on the screen
- Standby - Idles and displays advertisements

-Display Mode

- IATA airport code
- Flight Number
- Surname of bag owner

IATA	Flight #	Surname
US	8524	M. Haralambous
US	8524	S. Richie
FL	1608	T. Pytel
FL	1608	Q. Zhou
FL	1608	A. Sadmani

Android Stick - Software

-Standby Mode

- Configurable Advertisements

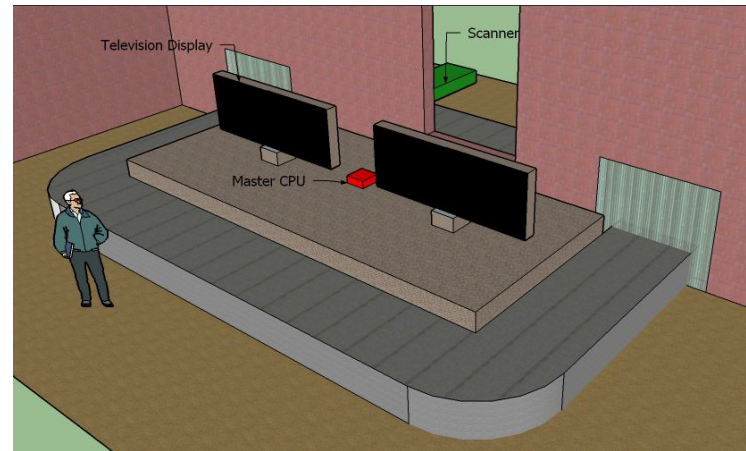
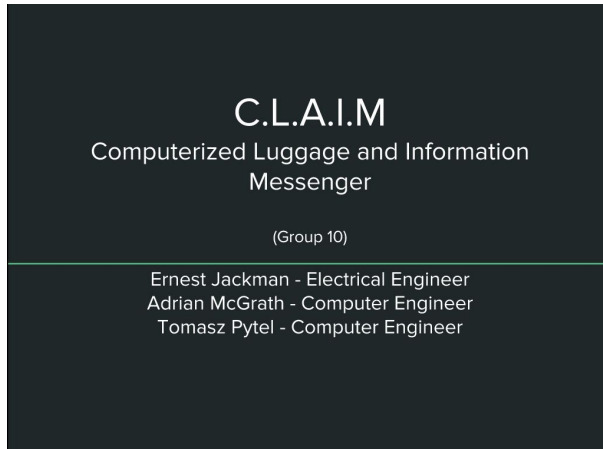

-Supports sensor orientation

Airline Services / Text Notification

-What the service does

-Why we leave it up to them to implement

- Realistic constraints such as existing airline apps
- Third party operation of text messaging services

-Customer Implementation Requirements

- Passenger notification service
- Passenger information linked with luggage

Test Results

Test Attempt	Display Time (Seconds)
1	1.1
2	1.53
3	1.25
4	1.21
5	1.26
6	1.2
7	1.11
8	1.1
9	1.15
10	1.15
Average	1.2

Test Attempt	Notification Time (Seconds)
1	1
2	1.43
3	1.15
4	1.1
5	1.16
6	1.19
7	1.1
8	1.1
9	1.09
10	1.13
Average	1.5

Expenses

-No sponsors

-\$600 Budget

Total	\$186.61
--------------	-----------------

<u>Item</u>	<u>Acquired Price</u>	<u>Net Worth</u>
Raspberry Pi 2B	\$43.00	\$43.00
4GB microSD card	\$5.99	\$8.00
USB to TTL to UART RS232	\$4.59	\$7.00
Trendnet Micro Bluetooth 3.0	\$12.19	\$14.00
Edimax Wi-Fi USB Adapter	\$9.23	\$11.00
MK808B Plus Android 4.4 Stick	\$28.77	\$32.00
Asus VE248 Monitor	\$0.00	\$177.99
PCB	\$31.35	\$36.00
Components	\$6.19	\$51.81
Miscellaneous Costs	\$40.31	\$44.00
Mounting/Demonstration Costs	\$4.99	\$4.99
TOTAL	\$186.61	\$429.79

Microcontroller/ RF Scanner - Ideal Features

- Scaled up to real world size
- Support for mounting to various conveyor systems
- Increase in power output for better coverage
- Certification for intentional radiation device

Master CPU - Ideal Features

- Master CPU On/Off switch
- System Pause/Continue options
- Dynamic Wifi Support

Android Stick - Ideal Features

- Aesthetic graphics
 - More pleasing graphics surrounding the display information

- Configurable Advertisement input
 - Allow easily modifiable file to swap in/out different advertisements
 - Perhaps create a service that uploads/updates advertisement information
 - Support for animated advertisements

Questions?

Project review:

- Scanning Unit (Bluetooth, MSP430, RF Tag Reader)
- Raspberry Pi (Information Processing, Airline Connection)
- Android Monitor (Visual Display of Data)
- Airlines Services