

# SMART UMBRELLA

## Senior Design II Documentation

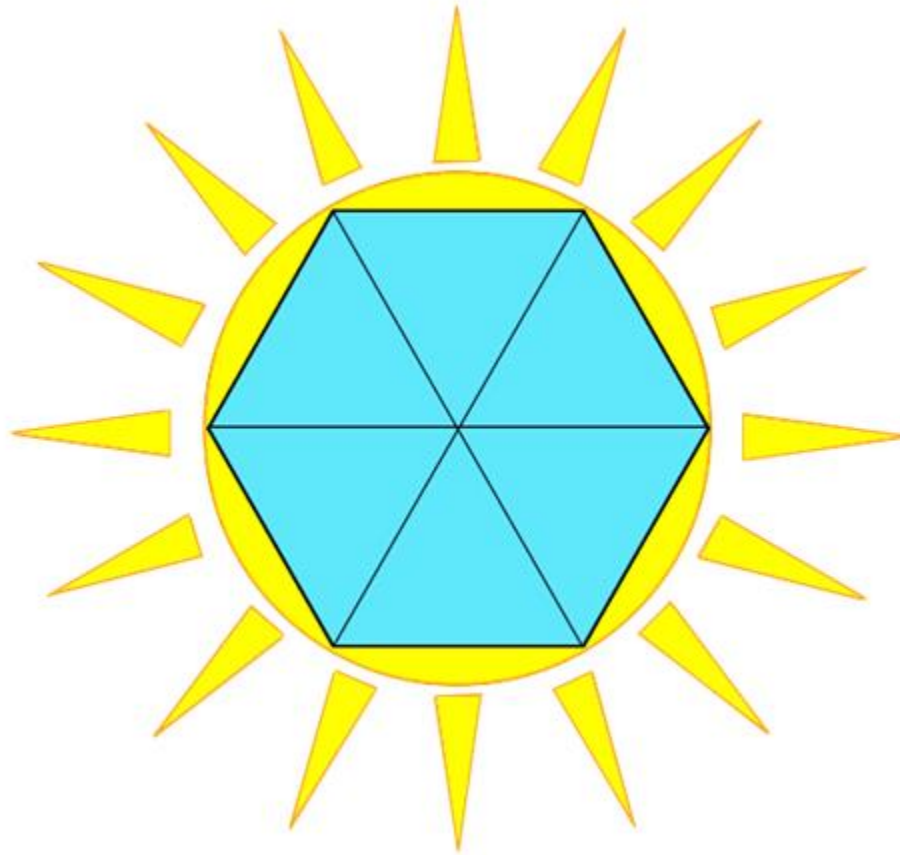

Department of Electrical Engineering & Computer Science  
University of Central Florida  
Fall 2015-Senior Design II  
Group #9

Eugene McDonald Electrical Engineering  
Derek Workman Electrical Engineering  
Nicholas Van Nice Computer Engineering

# TABLE OF CONTENTS

1.0 Executive Summary.....	1
2.0 Project Description.....	2
2.1 Project Motivation and Goals.....	2
2.2 Objectives.....	4
2.3 Requirement Specifications.....	5
2.3.1 Project Specifications.....	5
2.3.2 Motor Specifications.....	5
2.3.3 Lighting Specifications.....	6
2.3.4 Controller Specifications.....	6
2.3.5 Sensor Specifications.....	6
2.3.6 Battery Specifications.....	7
2.3.7 Photovoltaic Solar Panel Specifications.....	7
2.3.8 Maximum Power Point Tracking (MPPT) Specifications.....	8
3.0 Design Constraints.....	8
3.1 (ABET) Realistic Design Constraints.....	8
3.1.1 Economical Constraints.....	8
3.1.2 Environmental Constraints.....	9
3.1.3 Social Constraints.....	9
3.1.4 Political Constraints.....	10
3.1.5 Ethical Constraints.....	10
3.1.6 Health and Safety Constraints.....	10
3.1.7 Manufacturability Constraints.....	11
3.1.8 Sustainability Constraints.....	11
4.0 Research.....	12
4.1 Motors.....	12
4.1.1 Types of Motors.....	12
4.1.2 Product Comparison.....	14
4.1.3 Motor Control Method.....	15
4.2 Lighting Systems.....	17
4.2.1 Types of Lighting Systems.....	17
4.2.2 Product Comparison.....	20
4.3 Control Units.....	22
4.3.1 Types and Comparisons.....	22
4.3.2 Product Comparison.....	24
4.4 MPPT Algorithms.....	25
4.4.1 Types and Comparisons.....	25
4.4.2 Software Comparison.....	29
4.5 Sensors.....	30
4.5.1 Voltage Sensors.....	30
4.5.2 Current Sensors.....	30
4.5.3 Light Sensors.....	32

4.5.4 Product Comparison.....	33
4.6 Batteries.....	33
4.6.1 Types and Comparisons.....	33
4.6.2 Product Comparison.....	35
4.7 Photovoltaic Solar Panels.....	36
4.7.1 Monocrystalline and Polycrystalline Solar Cells.....	36
4.7.2 Thin Film Solar Cells (TFSC).....	37
4.7.3 Product Comparison.....	37
4.8 Solar Charge Converter.....	38
4.8.1 PWM vs MPPT.....	38
4.9 Universal Serial Bus (USB).....	39
4.9.1 USB Ports.....	39
5.0 Project Hardware and Schematics.....	40
5.1 Maximum Power Point Tracking (MPPT).....	40
5.1.1 Design.....	40
5.1.2 Microcontroller.....	41
5.1.3 Synchronous Buck Converter.....	41
5.1.4 Current Sensor.....	45
5.1.5 Voltage Sensor.....	46
5.1.6 Load MOSFET.....	47
5.1.7 LCD Display.....	48
5.2 Power System Design.....	48
5.2.1 Battery Charging Design.....	48
5.2.2 USB Charging Design.....	51
5.3 Controller System Design.....	51
5.4 Lighting Design.....	56
5.5 Motor Design.....	57
5.6 PCB Design.....	60
6.0 Project Software.....	62
6.1 MPP Tracking Algorithm.....	62
6.1.1 Overview.....	62
6.1.2 Software Block Diagram.....	63
6.2 Motor Control.....	64
6.3 Lighting Control.....	67
7.0 Project Construction.....	71
7.1 Pole Design.....	71
7.2 Motor 1 Structure Design.....	72
7.3 Motor 2 Structure Design.....	74
7.4 Solar Panel Location and Design.....	75
7.5 Circuitry and Battery Location Design.....	77
7.6 LED Lighting Location and Design.....	79

8.0 Prototype Testing.....	81
8.1 Overview.....	81
8.2 Testing Environment.....	81
8.3 MPPT Testing.....	81
8.4 Subsystem Unit Testing.....	83
8.5 Integration Testing.....	84
9.0 Milestone and Budget.....	85
9.1 Senior Design I Milestone Chart.....	85
9.2 Senior Design II Milestone Chart.....	86
9.3 Budget.....	88
10.0 Bill of Materials.....	89
10.1 Main Components.....	89
10.2 MPPT Components.....	90
10.3 Circuitry Components.....	91
11.0 Conclusion.....	92
References.....	I
Appendices.....	IV
Appendix A - Copyright Permission.....	IV
Appendix B - Datasheets.....	VII

# 1.0 Executive Summary

In an era where self-sufficiency and the need to stay connected, through technology, is mandatory. The group decided to create the Smart Umbrella. The group believes that the originality and the functionality of this umbrella will revolutionize the patio/beach umbrella market. Being outdoors is becoming more popular to people as they retreat from their homes and into nature. The group's vision was to create a low cost battery and solar powered umbrella that meets the needs of these customers. The main function of a patio/beach umbrella is sun protection. This umbrella meets these needs by using multiple sensors and a set of small stepper motors to automatically track the sun to maximize shading where the user is sitting. To accomplish this task, the group used solar panel arrays placed on top of the umbrella that are used in conjunction with a rechargeable battery pack. These solar panel arrays receive maximum sunlight as the top of the umbrella follows the sun. This increases the power capability of the solar panels. Maximizing shade was the number one driving force in this project, but utility was also important. To increase the user's ability to remain outdoors for extended periods without the need to chase down a cell phone charger to continue important conversations. The Smart Umbrella contains a USB port so the user can enjoy a day at the beach or in their backyards and be able to charge their phones when the phone's battery is running low. Another application of the Smart Umbrella is for night use. Twenty-four LED lights have been equipped to the top of the umbrella. The umbrella has six lighting modes. The first mode is constant lighting for the users that just wants to relax and read a book. The other lighting modes are for entertainment purposes and to show the programming capabilities of the LED driver. The LED driver uses SPI communication to the microcontroller allowing each individual light to be accessed. Not only will these lighting modes be for entertainment purposes, but they will also create a conversation piece in any situation. The sensors realign the motors at night and filter power to just the lighting. A push button switch activates the entertainment mode which slowly rotates the umbrella in a 360 degree rotation and includes the multiple LED modes. The group felt that the Smart Umbrella, with its low cost and utility, would be a hit in the consumer marketplace. The umbrella maintained its light weight and weather proofing specifications to ensure the users can enjoy the product and not have to worry about life expectancy. There is nothing like this on the market and the plan was to take advantage of this fact. To accomplish this task, the group needed to do hours of research. This research led to the design stage of the project which included designing the MPPT and Li-Ion battery charging PCB, designing the microcontroller PCB, and designing the pole of the umbrella to actually create a functioning prototype. Lastly the group tested through prototyping to ensure the umbrella was functioning correctly according to the design specifications. These steps ensured that the Smart Umbrella became a "must have" product in every outdoor adventure.

## **2.0 Project Description**

### **2.1 Project Motivation and Goals**

The main motivation for this project was to create a unique product that could be instantly marketable. This creates an extremely difficult problem right from the start. There are millions of people around the world trying to do the exact same thing. New products are released daily that are unique and innovative. First the group had to define a customer need, then that need had to be satisfied using the knowledge that has been obtained over years of study. Then a market had to be defined that the product could be tapped in to. This group has accomplished these tasks.

First a little background about the designers of the Smart Umbrella will be discussed. This background will give some insight as to the idea of the Smart Umbrella. All three of the designers currently reside in and go to school in central Florida. Florida boasts hundreds of miles of beaches and has some of the most famous beaches in the world. Florida also boasts multiple fresh water springs for the adventurous outdoor enthusiast. Many rivers and lakes also dot the state providing even more outdoor recreation. Many Floridians create elaborate landscaping getaways in their own back yard. All of these beautiful escapes from everyday life make Florida a prime location for this product. Florida is known as the sunshine state and it provides potential consumers with beautiful sunny days year round. However as many people who visit or reside in Florida can agree with, the sun can be a harmful entity that can actually harm and even kill people. Long term exposure to the sun's harmful UV rays has been shown to cause skin cancer or at the very least provide the outdoorsman with a very painful sun burn. Sun shielding umbrellas are a must have item in these environments. This fact provides us with a customer need that the Smart Umbrella can fulfill.

There are many different types of patio/beach umbrellas in the market that protect the user from the harmful UV rays. These umbrellas boast many different features that entice the consumer to purchase their product. The main features that patio/beach umbrella provide are UV protection, large shading area, and durable steel frames. Some of these umbrellas offer other features like lighting; crank operated opening capabilities, and manual tilt capabilities. This project combines most of these features and actually expands on the list of features provided to the consumer. This market is increasing dramatically every year as more and more people abandon their indoor activities to get out into nature. This market is the one in which we want to tap into with the Smart Umbrella.

Imagine retreating to your patio on a beautiful sunny Florida day to escape the doldrums of indoor activities. As you sit around your brand new patio furniture with sun shielding umbrella reading or conversing with friends on the phone, you realize that the umbrella is not really shading the area where you are sitting as the sun moves across the sky. Sometimes you are shaded and other times you

must continuously manually tilt your umbrella into a position that will shade you or risk the chance of receiving painful sunburns. What happens if you accidentally doze off in a lounge chair thinking that you will be protected from the sun but as the sun moves you wake up to find that you are no longer shaded and again have to face the dreaded painful sun burn remedies. One of the goals of this project was to provide the user with constant shading all day long. This will be accomplished by installing two separate motors into the pole design along with several sensors that will locate and track the sun's position. As the sun moves across the sky, so too will the Smart Umbrella providing constant UV protection with no user interaction needed. No more adjusting the umbrella to cover the desired shading spot will be necessary. No more frustrating issues with the umbrella falling over because adjustment was required that loosened the mounting system in the soft beach sand.

Another goal in this design is to make the Smart Umbrella completely self-sufficient. The reasoning behind this is so that you no longer have to purchase multiple umbrellas. One umbrella for the patio and another umbrella for the beach is no longer needed. You can just grab your patio umbrella and attach a screw base to it so that it can be used on one of many sandy beaches. This means that the Smart Umbrella will need to be light weight and easily transportable. The power source for the Smart Umbrella is environmentally friendly solar cells that maintain continuous powering of the system. This makes the Smart Umbrella extremely useful for any occasion where continuous shading is needed. Just pack up this lightweight design and go. Setup is easy.

This product also addresses another goal of the designers. That goal is to keep the consumer at one with nature. This product adds two more features that help achieve this goal. Imagine wanting to go relax under your umbrella in a quiet desolate middle of nowhere location and realizing when a family member or friend calls your cell phone that the battery is almost dead. Imagine being out in your backyard enjoying a cool breeze under your umbrella and again a family member or friend calls and you realize that your cell phone battery is about dead. In both of these instances you are forced to chase down a phone charger and try to find some source of power to charge your cell phone battery. What a hassle. The Smart Umbrella has also thought of you, it has come to the rescue by providing a dedicated USB charging port so that you can converse with family or friends and not have to run around looking for somewhere to charge your phone. Imagine again sitting around your patio furniture talking to friends in your constantly shaded Smart Umbrella and the sun begins to set behind some trees. As dark approaches you will not need to fear. The Smart Umbrella will return to its upright position and switch on the multiple LED's thus providing lighting so that the party can continue. There will be no need for you to retreat into the house. Both of these features keep the user outside in their favorite retreat thus achieving the goal set above.

The last goal is another unique feature that will be incorporated into the product. This feature is an entertainment mode. This mode causes the Smart Umbrella to

slowly rotate around in a continuous 360 degree rotation. It also individually runs one of the five entertainment modes that have been built into the design. This mode will be a conversation piece and distinguish the Smart Umbrella from any other patio or beach umbrellas. Along with some of the features listed above. This product will meet all of the goals listed thus creating a unique product that can be instantly marketable.

## **2.2 Objectives**

One of the main objectives that the group achieved in designing the Smart Umbrella was to show that the group members have the skills needed in the engineering field to be competitive in a very competitive line of work. Two of the group's members are aspiring power engineers. While the third group member now works programming FPGA's. All three group members needed to combine their knowledge and step outside their comfort zone to design build, and test the Smart Umbrella. The group feels that we have met this objective. We have accomplished this objective by designing, building and testing a 90 percent efficient or better synchronous switching regulator utilizing Maximum Power Point Tracking algorithms. Incorporating solar panels into the design increased the difficulty of building the power supply. This introduced a variable power source that needed to be properly regulated using this highly efficient MPPT circuit. Because this circuit had many components and needed a controller to collect data from the sensors, as well as, output data into the circuit, this was not an easy task.

Another way, in which the group showed that they have met this objective, was to incorporate another power source into the design. This power source is a rechargeable Li-Ion storage battery. This again complicated the design by forcing the group members to design, build, and test a charging system for the batteries for the project. A USB charging port was also utilized in this design which actually incorporated a third charging system into the design.

Finally the last way that the group met this objective was by using sensors and a motorized system to accomplish a specific task. A programmable lighting configuration was incorporated into the design. This required the design of multiple power sources with a restricted amount of power supplied. All of this was done by meeting stringent design specifications listed in section 2.3.1 below.

Another objective the group accomplished in this design to build a Printed Circuit Board (PCB) for the circuitry. This required the learning and mastery of a CAD program. The group used the Eagle CAD program to obtain this objective. This was outside the comfort zone of all of the members as none of us have ever used this sort of program in any past designs. Many of the schematics used in this paper were designed by the group members after a steep learning curve. Special considerations were needed in setting up a PCB board using the Eagle CAD program. There was little room for error in the PCB layout, because of the many components in this design and precise PCB board layout was needed.



## **2.3 Requirement Specifications**

### **2.3.1 Project Specifications**

A complete list of design specifications is listed below. Each of the component specifications in sections 2.3.2 - 2.3.8 was listed keeping the following project specifications in mind. These primary specifications are:

- Lightweight design - The final product does not weigh more than twenty pounds in total weight.
- Low cost - total added components (not including umbrella cost) do not exceed \$200.00
- Energy Efficient - all components in the circuitry will be rated at 90 percent efficiency or greater.
- Long lifetime - All components added in the design will maintain operability for a minimum of five years under normal operating conditions.
- Low user maintenance over projected lifetime - user will only need to change battery pack in the event of failure due to maximum charging cycles. No other user maintenance is required.
- Durable - Must be able to handle normal operating conditions. Which include being carried or stored in any position and relatively small shocks from carrying, storing, and set up
- Weather resistant - All components are weather resistant and able to withstand high temperature and humidity conditions.
- Transportable - The finished product is easily foldable for minimum difficulty in transporting.
- Easy setup - Must be able to setup the umbrella using very few setup instructions. No tools required setup.
- USB 2.0 dedicated charging port - provides a max 0.5 A charging capability
- LED lighting
- Entertainment mode - dancing umbrella mode
- LED battery charging status indicators
- User friendly operating status display with backlit LCD screen

### **2.3.2 Motor Specifications**

To achieve the specifications listed above in section 2.3.1, there are certain specifications the motor must adhere to as well to make certain the project will function. The motors need to be:

- Low voltage - the motors need to run off the batteries if there is no sunlight for the photovoltaic cells. Running voltage of less than 8.4 volts.
- Low amperage - the motors need to run on as less than 1.0 amp.
- Low cost - both motors need to cost less than \$100.00.
- Lightweight - the motors together need to be less than 1 pound in order to keep the overall weight of the unit down.
- High torque - need to have a torque output higher than 2560 oz.\*in.

- Efficiency - need to maintain the most efficient conversion of electrical to mechanical power.
- Precise - the motors need to be able to be moved to a fixed position or rotate a certain number of times to move the unit to a certain position.
- Controllable - needs to be controlled by the controller used on the unit.
- Weather resistant - the motors must be able to operate in sandy and watery conditions in order to function outside at the beach.

### **2.3.3 Lighting Specifications**

To achieve the specifications listed above in section 2.3.1, there are certain specifications the lighting system must also abide by in order for the project to function as intended. The lighting system needs to be:

- Low voltage - the lights need to run off the batteries during night time usage. Running voltage less than or equal to 7.4 volts.
- Low amperage - the lighting system needs to run on as less than 0.5 amps in order make sure the system will not drain the battery too quickly.
- Low cost - the lighting system needs to cost less than \$30.00.
- Lightweight - the lighting system all together needs to be less than 0.25 pound in order to keep the overall weight of the unit down.
- Efficiency - needs to maintain a low power draw in order to make the battery last several hours with just the lighting system activated.
- Controllable - needs to be controlled by the controller used on the unit.
- Weather resistant - the lighting system must be able to operate in sandy and watery conditions in order to function outside at the beach.

### **2.3.4 Controller Specifications**

Meeting the project specifications listed in section 2.3.1, the control unit has to be compatible with the entire smart umbrella.

- Low voltage - The control unit has to be able to run on an operating voltage of 5 volts.
- Input voltage has to be able to range from 6V-20V and preferably lower to the 7V-12V range.
- Low Cost - control unit has to be under \$50.00, to make the umbrella be manufactured at a low cost to be competitive in today's market.
- Clock speed at around 16 MHz
- Must have 30+ digital I/O pins
- Must have analog input pins
- Must have flash memory of 256 KB
- Powered by battery
- Must be weather resistant

### **2.3.5 Sensor Specifications**

To achieve the project specifications listed in section 2.3.1, sensors will have to meet its own requirements for an efficient design. There are currently 3 different

types of sensors the smart umbrella will utilize. The umbrella will need voltage, current and light sensors.

- Service life - must be durable and last long
- Large availability - depending on design may need multiple sensors of each kind.
- Lightweight - To fit the specification of having a light transportable umbrella, they need weight as less as possible
- Low cost - To meet the consumer market, they will have to be of low cost
- Fast Operating time - Must be able to communicate with the microcontroller at a fast rate
- Repeat accuracy - plus or minus 3 pct. max
- Current Sensor must operate at a minimum of 7.4 volts
- Current Sensor must have an output current of less than 4 mA
- Light dependent resistors must have fast rise time and slow fall time
- Weather Resistant - Must be operable in any environment

### **2.3.6 Battery Specifications**

To meet the project specifications listed in section 2.3.1, battery specifications will also need to be declared for the group's power storage. The batteries need to be:

- 7.2V nominal voltage - must have enough voltage to be able to power the added components in the project.
- Low cost - need to cost less than \$50.00 with shipping included
- Large availability - need to be readily available to be able to find replacements.
- Lightweight - The batteries will be considered in the total project weight so they need to be less than 1 pound.
- Rechargeable - Minimum cycle life of 300 cycles.
- Small size - be able to fit in 1.25 ID pole or small external packaging
- High power output - 10 watts per hour output capability.
- Flat discharge rate - will need to have a steady current output over time
- Medium output duration - maintain normal operation for a minimum of 3 hours.
- No "memory effects" - the batteries will need to be recharged multiple times without having to discharge the battery packs before charging.
- Durable - Must be able to handle normal operating conditions. Which include being carried or stored in any position and relatively small shocks from carrying, storing, and set up

### **2.3.7 Photovoltaic Solar Panel Specifications**

To meet the project specifications listed in section 2.3.1, specifications will also be needed to help choose the photovoltaic supply. The solar panels need to be:

- Lightweight - Since the solar panels will be considered in the total project weight. These panels need to weigh less than 1 pound.
- Low cost - The PV panels need to cost less than \$100.00.

- High power output - The panels need to be able to output greater than 7.4 volts for charging the batteries and have a minimum current output of 2 Amps. A minimum of 14.8 watts is required.
- Weather resistant - This product will be used in outdoor conditions. The panels need to be able to withstand direct sunlight and heavy humidity conditions.
- Flexible - These panels need to be placed on an umbrella which will need to fold up for storage purposes.
- Durable - These panels need to be able to operate in normal operating conditions, which may include small shocks due to transporting, storing, and set up.

### **2.3.8 Maximum Power Point Tracking (MPPT) Specifications**

To meet the specifications in section 2.3-1 the Maximum Power Point Tracking unit will need to meet a list of specifications. These specifications are:

- High efficiency - The MPPT will need to be greater than 90% efficient.
- Low cost - The MPPT must cost less than \$100.00.
- Durable - The MPPT circuit will need to be able to operate in normal operating conditions. These include small shocks due to transporting, storing, and set up.

## **3.0 Design Constraints**

### **3.1 (ABET) Realistic Design Constraints**

Constraints are design decisions that restrict the design process. ABET realistic design constraints include the following eight types: economical, environmental, political, ethical, health and safety, manufacturability, and sustainability. Researching the NSSN and HIS websites for standards gives the group ideas on real world design constraints that affect the project. A few examples of each of these types of constraints that affected the design of the product are given in sections 3.1.1 - 3.1.8.

#### **3.1.1 Economical Constraints**

Economic constraints are restrictions on the design that may affect the cost of the product. One of the economic constraints was prototyping and design cost. The group has decided on a \$650.00 design and prototyping limit. This will limit the resources available and cause the group to look for cheaper but effective means of achieving the design and prototyping build. Another reason that this limit was chosen was because the three group members completely financed this product with no outside help. The patio umbrellas that are in the market today range in price from \$20.00 to a few hundred dollars depending on the quality and features included in the product. This limits the manufacturing cost of the designed product once the design and prototyping is complete. The group has decided that the final product should add no more than \$200.00 to the cost of the umbrella used, as this may vary quite a bit depending on the quality of the

umbrella. For the prototyping a cheaper lighter patio umbrella was chosen to keep design costs down. If this goal is unachievable, other models of this design could be introduced with fewer features which may attract a larger target consumer base. For this project all of the features were added to show what features are available. Purchasing the components in bulk directly from the manufacturer will also decrease the building costs. For this project most of the components were purchased through a third party seller. This adds to the cost of the components significantly, approximately doubling the cost of the components.

Another constraint that may affect sales of this product will be shipping costs. Because the battery pack chosen was lithium ion. Lithium ion batteries have restrictions for shipping by plane. These battery types cannot be shipped by commercial airlines. These batteries must be labeled as dangerous goods and meet the dangerous goods specifications established by the International Air Transport Association (IATA). For global shipping the specifications established by the International Civil Aviation Organization (ICAO) which is a UN regulated organization that establishes specifications for shipping hazardous material by air must be met. This shipping cost increase could raise the cost of the Smart Umbrella for the customer. This may affect the customer's decision on buying this product and will need to be taken into consideration.

### **3.1.2 Environmental Constraints**

Environmental constraints are constraints on how the product may affect the environment in which it may be used. One of the environmental restrictions for electrical components is the Restrictions of Hazardous Substances (RoHS). This restricts the amount of six hazardous materials found in electrical components. These six materials and the amounts allowed are: Lead < 1000ppm, Mercury < 100ppm, Cadmium < 100ppm, Hexavalent chromium < 100ppm, Polybrominated Biphenyls < 1000 ppm, and Polybrominated Diphenyl Ethers < 1000 ppm. The battery pack and all electrical components purchased for this project are RoHS compliant and meet these standards. Another decision that was affected by this standard was the choice of thin film technology solar cells. CIGS was chosen for other reasons, as well as, the fact that it is more environmental friendly than its main rival Cadmium Telluride which contains cadmium, a highly toxic substance. This product will be very environmentally friendly. It will not contribute any pollution to the surrounding environment, including noise pollution. The two motors chosen will be quiet running stepper motors that produce very little noise during their operation.

### **3.1.3 Social Constraints**

Social constraints are the type of constraints society places on a product. The customer expects a certain product to work or look a certain way. The main social constraint for this project will be the final look of the Smart Umbrella. Consumers expect an umbrella to look a certain way. There will be thin film solar cells located on the top of the umbrella. The main reason for deciding on building a solar array from individual solar cells was due to the fact that they could be placed in a less restricting and visual pleasing pattern instead of just

draped across the top. This will allow the umbrella to be folded when not in use for storing purposes.

### **3.1.4 Political Constraints**

Political constraints are those types of constraints that affect the design due to political reasons. This product will not in any way discriminate from different races of users or any other discriminatory factors. This product will in no way be used or specifically sold to consumers who intend to do the United States harm. This product will not be sold with the intention of harming the consumer physically or emotionally. The group was hard pressed to find an example of a political constraint that could cause a restriction in this product.

### **3.1.5 Ethical Constraints**

Ethical constraints are restrictions on a product due to ethical concerns. This product will be designed using high quality parts. This product will work as advertised. It will not be just thrown together using cheap parts and sold for a massive profit. The product will be built solidly enough so that it may be used in any type of normal activity which involves the normal setup and use of the Smart Umbrella. The product will be safe for users and does not use any sort of hazardous materials that may harm its users. No data from the users is required so data storing issues do not apply. The only ethical constraint that will affect the design is product safety. Multiple safety backup systems will be incorporated into the circuitry design to guarantee the safety of the user. This will increase the cost of the design but is an ethically sound decision.

### **3.1.6 Health and Safety Constraints**

Health and safety constraints are any restrictions on product design due to the health and safety concerns. The IEC 61730 and EN 61730 standards are for PV module safety qualifications. It classifies solar panel applications based on voltage and safety restrictions. Since the solar cells, the LED's and some sensors will be located near the umbrella's cloth top special considerations will need to be considered with the heat disbursement and any electrical connections that may cause fires and harm the users. All electrical connections will require a minimum of 1Mohm between components and surrounding material per IEC 61032 standards. In this project this will be achieved by placing the connections in a rubberized shrink tubing that will then be heated causing the rubber tube to glue itself to the connection thus forming a greater than 1Mohm resistance between parts. This will also create a watertight and salt mist protection between the components and the environment which they may be used. All connections and components will also be thermally tested to verify that they do not come anywhere near the flash point of the umbrella material. This will be done using a digitized thermal meter at every connection and component. This issue will also affect the circuitry and battery pack. The battery charging circuit will contain a thermistor that will shut the charging system off in the event that the battery pack becomes too hot during its charging cycle. Small venting in the sides of the packaging box may also help vent the circuits and battery packs maintaining a safe temperature. The lithium ion battery pack was also purchased with a built in

PCB to keep the battery from overcharging which may cause explosion or harm to the user. Another safety aspect that has been incorporated into the design circuitry is two five amp safety fuses in case there is a short in the solar panel wiring or in any of the load wiring. These will disconnect the solar panel from the load or the load from the batteries in case of a catastrophic failure. A safe battery charging chip will also regulate the battery charging system and decrease the chance of the battery having some sort of failure resulting in injury to the consumer.

### **3.1.7 Manufacturability Constraints**

Manufacturability constraints are restrictions that may affect the manufacturing of the final product. One standard that may affect the manufacturability of this product was found on the NSSN website document number DIN EN ISO 9223:2012. This standard was created to classify the corrosion of metals and alloys. It defines the corrosivity categories for the atmospheric environments by the first-year corrosion rate of standard specimens. This includes corrosion due to temperature humidity complex, pollution by carbon dioxide, and airborne salinity. This will be a constraint for this project because of the potential use by consumers to use this product in high humidity, high heat and salt mist conditions. Proper coating of all steel parts will need to be addressed when designing or altering the umbrella pole or splines in the umbrella as they may corrode over time. The umbrella purchased now conforms to this standard by using a powder coat over all steel parts. This greatly reduces the corrosion of the metal parts. This constraint will also need to be considered on any external wiring going to solar panels and LED's. Proper covering of these parts will be required to maintain the lifetime of the product. Both of these will increase the cost of the project and need to be considered in the final design.

Special consideration will also need to be addressed in safely routing wires around any moving parts on the Smart Umbrella. This includes the areas around the motors, the splines where the led and solar panel wiring will be routed, and the solar panel location that will allow the umbrella to be folded during storing, and the pole itself where proper length will be maintained for folding the umbrella. These areas will require much thought in the design to keep wires routed where they will be unable to be pinched, severed, or even twisted into a bunch due to the 360 degree spinning motor. All wiring will be run inside the hollow umbrella pole as much as possible to protect them from damage. Any external wiring will need to be suitably protected and hidden from sight as much as possible. This restricts the way the umbrella can be built and increase the cost of the design.

### **3.1.8 Sustainability Constraints**

Sustainability constraints are constraints that that affect the operational lifetime of the product under normal operating conditions. The product will be warranted for manufacturing errors for 1 year. Because the cost of the final product may be \$300.00 or more depending on the type of patio umbrella used and the features model selected. The group believes that a target of a five year product lifetime should be achievable. This requires that all components be of high quality and

also have a five year lifetime. This lifetime does not include the battery pack which falls under user maintenance. Special considerations in the components packaging will need to be considered for easy battery replacement by the consumer.

## **4.0 Research**

### **4.1 Motors**

#### **4.1.1 Types of Motors**

In most applications of moving components in the world of electronics, there are three primary types of motors used. There are direct current motors, servos, and steppers. Each type has its own unique advantages and disadvantages. In order for the group to choose the correct motor for the project, the specifications from section 2.3.2 will be used as their guide. The primary things to look for in choosing a motor for this project is the ability to control the motors to move to a certain position or rotate a given number of times. Another feature that is crucial to the project is the amount of torque the motors can exert. This must be as high as possible while keeping in mind that the overall weight of the motors are considered into the weight of the project. Choosing the correct motor was critical to the design of this project. Next the group will look over each motor type in greater detail to hone in on the motor that would meet the desired constraints.

Direct current motors are the first type that will be considered. This type of motor uses direct current to rotate the motor. There are two main types of direct current motors, which are very similar in design. First there are brushed motors. Brushed motors come in either an electromagnetic or a permanent magnetic, which is mainly used in smaller motors. Due to the fact that high torque is needed, and that it is the most common type available, the group examined the electromagnetic version of these motors. There are two subcategories that are available to exam for electromagnetic based motors. These are series or parallel configuration. In the series model, the stator electromagnetic is connected in series to the armature coil. This produces extremely high torque but as the motor experiences a load force this drops quickly. The other configuration is the parallel or shunt model. In this form the stator electromagnetic and the armature coil are connected in parallel. This results in a greater performance as a load is applied to the motor, however this comes at a lower start up torque. The second type is the brushless motor. Brushless motors tend to be better choices for direct current motor design due to their longer life and are maintenance free. This is caused by the fact that they have no parts to wear down like the brushed motors. They are also much quieter than the brushed design. Another aspect to look at is the efficiency of the motor. Brushless motors are around 85-90% efficient, compared to the 75-80% efficiency of the brushed design. Another benefit of the brushless design is they are lighter than their counter parts which help met the design specifications in section 2.3.2. Direct current motors have their



disadvantages that need to be considered. They do not meet the control requirement that is need for this project. Direct current motors have only a small degree of control. This is done by pulsing the current sent to them. However this only allows for the control of speed of the motors not the exact position of the sensor. Another major problem is the motors are counter electromotive force or "back emf." This is the caused by the reverse of the current opposing the normal current flow due to the coil moving in a magnetic field. At a high enough frequency this will effetely cancel out the current being supplied. Because of these major disadvantages, these motors will not be used as the drive force to move this project.

In order to make direct current motors more applicable to precise applications they are often packaged as servo motors. Because direct current motors have no feedback and thus lose some degree of control, it was desired to track the position of the motor. This is done by way of a potentiometer. Most servo motors use gear boxes to turn both the potentiometer and whatever is being rotated. To collect info form the potentiometer most servos have an integrated circuit. This supplies the position of the motor to the controller as well as controls the movement of the motor. This movement is controlled with pulse width modulation. These motors are very precise as the control signal tells the motor the position not the speed. Most servo motors are limited to a certain angle they are able to operate within. These motors are not able to be used because the group needs to be able to rotate in a full revolution more than once. These motors also suffer from low torque to size ratio. With both of these in mind it is determined that servo motors are not the best choice for this project.

Stepper motors are a very versatile motor type. They are relatively new type of motor that was made to replace servos. They work similar to how the direct current motors works. They have several differences that help them stand out from other motors reviewed here. The reason this motor is picked over a servo motor is because it has an open loop control system. Theoretically this allows for control with no need for a feedback loop or a closed loop design like servos. This is great for applications where feedback is not possible or it is preferred to utilize a system without any feedback. This feature does have a downside and this will be discussed later. One major difference is that the rotor is magnetized axially. This is different form the radially magnetized direct current motor. Another difference is the rotor and the stator both a doubly salient design, which means have little gear like teeth that protrude from each structure. The number of teeth on the rotor is two less than the number of teeth of the stator. When the coils are energized the rotor teeth line up with the appropriate stator teeth. They also repel away from the opposing sign. This creates a "step" movement of the motor. If this pattern is done quickly it makes a constant motion. The change from one coil to another constitutes a 1.8 degree rotation, this is called full stepping. There are two ways to do this, one phase, and two phases. Two phase gives stronger torque performance over one phase. Another phase type is one-two phase, also called half stepping. This type of motions gives a 0.9 degree rotation of the rotor. Unfortunately this causes a ripple effect because

half the time it will have double the torque output. This can be corrected using a current correction technique and pulse width modulation. If this was implemented, quarter stepping and micro stepping can be achieved. For the need of this project the group will focus on the two phase full stepping control as the group doesn't need any higher degree of control over the position of the rotor. This control scheme will give us maximum torque output of the stepper motors. Now there are two primary type of stepper motor design, bipolar and unipolar. The main difference between them is, the unipolar stepper motor has a wire lead tap in the middle of the coil. This allows only part of the coil to be powered at a time. This gives greater control over what sections of the coil are powered. Unfortunately because of this the unipolar motors tend to have less torque than bipolar. Another downside to the unipolar motors is that the wires tend to be thinner than the bipolar design more wire must be used. This increases the overall resistance in the windings and therefore causes more heat to be generated inside the motor. This also creates loss of electrical energy in the form of heat therefore reducing the overall efficiency of the motor. For these reasons it is desired to look at the bipolar design of this motor type. Bipolar design is not without its own disadvantages though. Bipolar stepper motors are more complicated to control and require more sophisticated circuitry. They also require two different voltage inputs whereas the unipolar only requires one. This type of motor meets many of the requirements of the specifications listed in section 2.3.2.

#### **4.1.2 Product Comparison**

After reviewing over the different motor choices that the group has to pick from, it is determined that the stepper motor most matches the desired specification from section 2.3.2. Moving forward the group will be comparing different makes of stepper motors for the project. To recap the group will be looking for a bipolar stepper motor with high torque output. The three motors that the group will consider are in the Table 4.1.2-1.

As Table 4.1.2-1 shows the choice for this project will be the 14HS17-0504S and 14HS13-0804S-PG19. The design requirements from section 2.3.2 restricted greatly the group's choice of motors for this project. This motor is the obvious choice for the group as it meets all the requirements for the design. Most of the stepper motors on the market are designed to operate at 12 volts. The group didn't want to step up the voltage from the battery because it would mean a reduction in the amount of available amperage that the motors would have at their disposal. This motor operates at 12 volts which means that the group may have to change the incoming voltage from the battery. After initial testing the motors worked fine under the load from the battery without stepping up the voltage. Because the group went with a bipolar design we are getting a larger amount of torque over the unipolar design. As with all stepper motors, this motors will need to be controlled in order to create constant motion. In order to do this the motor coils within the motor must be turn on and off in sequence. In order do this the group needed to do research into control methods.

	324 Adafruit NEMA 17	14HS17-0504S	14HS13-0804S- PG19
price	\$14.00	\$13.00	\$38.00
operating voltage (volts)	12	12	12
operating amperage (milliamps/phase)	350	500	800
winding resistance (ohms/phase)	34	15	6.8
holding torque (ounce-force inch)	28	32.6	396.5
number of leads	4	4	4
degree per step(degrees)	1.8	1.8	0.094
winding inductance(millihenry/phase)	4.3	26	10
weight (pounds)	0.570	0.485	0.705

Table 4.1.2-1

### 4.1.3 Motor Control Method

Stepper motors operate on energizing coils in a certain sequence. In order to control the motor the group must understand how the motor operates internally. After the research outlined in section 4.1.1, it is understood that in order to achieve two phase stepping on the bipolar the group must send current into the correct coil to make to the motors rotate. Figure 4.1.3-1 shows the full rotation of the rotor when the coils on the stator are energized in the correct order. This is a much simpler design than what the stepper motor looks like internally in order to see the rotation of the rotor.

In this project, the group will be using a microcontroller in order to create the correct coil sequence in order control the motor. After reviewing the choices outlined in section 4.3, it is noted that the power supplied to the controller is 5 volts. In order to control the motor there must be some interface between the microcontroller and the power coming from the solar panels. After reviewing the different ways of controlling stepper motors it was decided that a driver will be utilized in order to act as a gateway between the microcontroller and the motors. The benefit to using a driver is that the incoming power form the solar panels can be fed into the driver along with a control signal from the microcontroller. In order to operate the motors the driver must be able to tolerate the 7.4 volts coming from the battery. It must also be able to receive a signal from the microcontroller. As most stepper motor drivers in the market operate at 12 volts it restricts the number of choices the group has when looking for the driver.

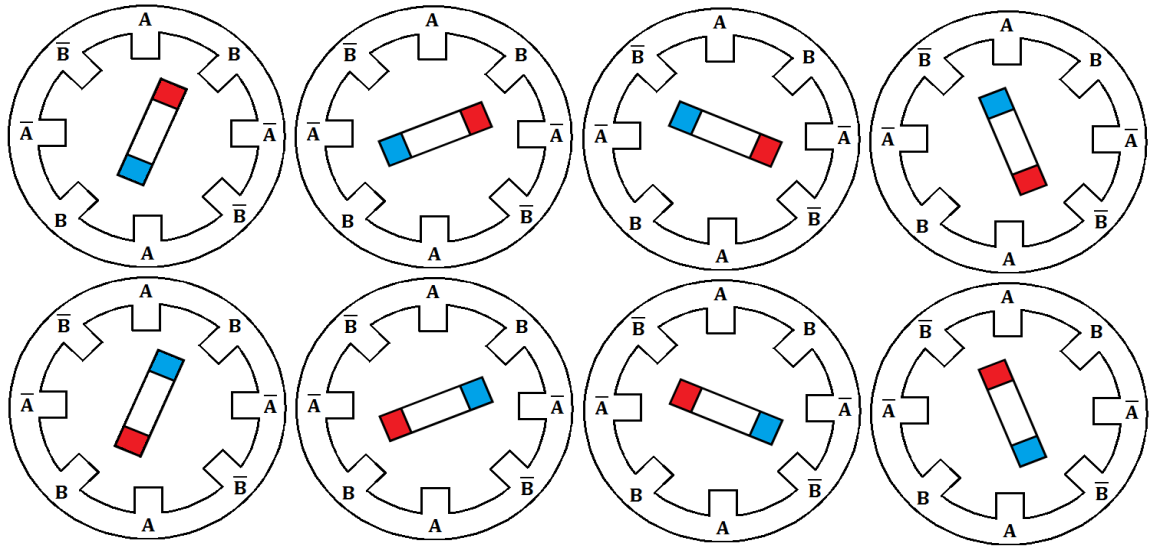

Figure 4.1.3-1 Full rotation of rotor using two phase stepping.

After much searching the group found a driver that meets all the requirements that are needed in order to control the motor selected. Below in Table 4.1.3-1 are the specifications of the driver the group has chosen.

model number	ROB-12779
motor voltage range(volts)	6-30
motor current range(milliamps/phase)	±150-750 user controllable
digital control input(volts)	0-3.3 or 0-5 user selectable
step mode	full, half, quarter, eights

Table 4.1.3-1

As shown in Table 4.1.3-1, this driver will take the 7.4 volts from the battery. The current range can be selected by the group by way of a potentiometer; the motor selected by the group is with the range of the driver. The driver will also be able to be controlled by the microcontroller using the digital input. This driver is able to run the motors in full step two phase modes. Another feature that is very important to the group's project is the sleep mode. In this mode the driver will stop power to the motors to conserve energy. This will improve the efficiency of the group's project. This driver makes use of the Allegro A3967. This integrated circuit has several internal circuit protection. First it has crossover-current protection as well as under-voltage lockout. It also has thermal shutdown if the temperature exceeds the threshold.

## 4.2 Lighting Systems

### 4.2.1 Types of lighting systems

Over all the years that mankind has been utilizing electricity for the purpose creating artificial light; one type of lighting system has reigned supreme. This was the incandescent light bulb. In more recent years, as technology has advanced, new types of lighting have been introduced to the market. The two other types of lighting systems that are widely popular in the market are fluorescent lamp and light emitting diode. For the purpose of this project, the group will review three different types of lighting systems to see which one will best fit the specification outline in section 2.3.3. One of the main things for the group to focus on for the lighting system is it must be able to run off the battery of the unit. With this in mind the system is limited to the maximum voltage and current available to the lights. Another important aspect to remember when selecting the lighting system is the fact that the system must be able to be controlled by the main microcontroller of the unit. This is required because the unit will need to turn on the lighting system when there is not sun present in the sky. The project will also have an entertaining mode in which the lighting system will need be flashed on and off. Next the group will review the three different types of lighting system to see which one will be the correct choice for this project.

The first type of lighting system that will be compared is the incandescent light bulb. The technology for this system has been around for many years. This has been the predominant lighting system used commercially and residentially for many years. The reason for this is that the incandescent light bulb is a very simple design, easy to manufacture, and easy to implement. This type of lighting system is easily controllable by many methods; in this area it fills the need of the controllability aspect of the lighting specifications from section 2.3.3. The name of this lighting system gives some insight into how the design of the system works. The term incandescence means to produce visible light by way of heating up a thin filament. The filament in is made of thin piece of tungsten encased in a glass bulb. The tungsten filament is connected to two contact wires which connect to the base and foot respectively. In order to keep the filament from evaporating too quickly the glass bulb is either filled with an inert gas, or a vacuum is created in the chamber. As current is passes through the filament the tungsten heats up and produces light. As the tungsten heats up it evaporates into the glass bulb, over time this erodes the filament down until it's too thin to withstand the current passing thought it and it fails. This also lines the glass bulb and creates a less bright light output for the light bulb. To try to correct these problems, halogen light bulbs were created. This subtype of incandescent light bulb uses the halogen cycle to reduce the loss of tungsten. This is done by filling a quartz chamber with a halogen gas. Because of the persistence of the gas in the tube, a reaction on a chemical level reduces the amount of tungsten that adheres to the inside of the quartz bulb. This greatly reduces the amount of tungsten lose, with the added effect that the tungsten that evaporated will redeposit back onto the filament. This means that the life of the bulb is longer

than that of a normal incandescent light bulb. Because of the added advantages of the halogen light bulb, this type of bulb will be the focus of this section's review. There are many advantages this this design of light compared to lighting types that exist. This type of light is light weight, so it will have little overall effect to the weight of the project. Due to the simple design of this lighting system, it can run on either alternating or direct current. Wiring this type of light into a system is very easy to accomplish. If this type of light were to go bad it would be easy for the customer to replace this type of bulb, it simply screws into the socket. It is also simple to control this light, and it can flash and dim very easy. It also is an instant on, meaning that as soon as you turn the light on it lights up. Some disadvantages are that this type of light is very inefficient because most of the electricity used is converted into heat. This means that most of the electricity is wasted due to heat lose and not actually used for lighting purposes. Only ten percent of the electricity is converted to light, with the rest going into heat. Because of this heat it can cause a fire risk also, if it is too close to the umbrella's fabric top. Another problem with this light is that when the umbrella is closed, it would crush the bulb. This type of light takes a lot of voltage to produce a good amount of light. There are lower voltage bulbs in the market but they are low on the luminosity scale. Lastly, incandescent light bulbs are actually being phased out due to the Energy Independence and Security Act of 2007. The production of many kinds of incandescent bulbs was ceased in the year 2014. This will make obtaining the bulbs more complicated than is desired. This will also affect the customer's use of this product. Because of these faults in obtaining the bulbs, and the low luminosity per volt, this type of light system will not be used for this project.

The next type of lighting system that the group will consider is the compact fluorescent bulb. In recent years the compact fluorescent bulb has been introduced into the market as a replacement for the incandescent light bulb. The technology behind the florescent light bulb has been around for more than 100 years despite that they have been available in the market in recent years. This was due to the fact that it was too costly to produce at the time of the invention. As technology has advanced, the cost to make the compact fluorescent bulbs has decreased to a level that the residential market can purchase them. The design of the bulb has remained the same as the efficiency has improved. The bulb is made from glass tube coated with phosphors, filled with mercury-argon vapor. At each end of the glass tube is a cathode that emits electricity. This electricity creates an arc that excites the mercury molecules which in turn releases ultraviolet light. When this ultraviolet light collides with the glass tube, it reacts to the phosphors to produce visible light. To create more compact lights the glass tube are curved and spiraled to reduce the overall size while keeping the same length. All of the current flowing through the arc must be controlled; this is done by way of something call a ballast. There are two different types of ballast, electromagnetic and electronic. Electromagnetic ballasts use a transformer to limit the current flowing into the arc. The downsides to these are they create a noise and heat; this can be reduced by encasing it in asphalt. The

other type of ballast is the electronic type. This ballast works using modern solid-state circuitry. This is used to limit the amount of current given to the arc. This design is what is used in compact fluorescents because it is quieter and produces less heat than the electromagnetic versions. Because of these benefits of the electronic ballast the group will only consider light powered by this ballast type. In an effort to create a more efficient light, high intensity discharge light bulbs were developed. This type of bulb uses a similar principle to the fluorescent light bulb. Two electrodes composed of tungsten are encased in a quartz tube. This chamber is filled with a gas under high pressure. The tube is encased in a glass bulb. An arc is created between the two electrodes within the tube. Because of the high pressure the gas is under, it creates a high intensity light source. This type of light design has a higher efficiency than that of the compact fluorescent. This does come at a price though. In order to set up the arc, the high intensity discharge lamps have a long warm up time. Another problem with the arc is once the arc is turned off, it takes time for the tube to cool down and return to a lower pressure where the arc can restrike. Because of the reasons, high intensity discharge lamp will not be reviewed for this project, as it is unable to turn off and on the light quickly in entertainment mode. Now the group will review the advantages to the compact fluorescent light bulb. This light design is much more efficient design than the previous incandescent light bulb. Because more of the electricity is converted to light it reduces the amount of heat that is created by this lighting system. Because of the electronic ballast, wire of this system will be simplified compared to the electromagnetic ballast. Modern bulbs are instant on, compared to older version of these bulbs. This is necessary for the flashing mode that this project is expected to perform. With all the benefits that the compact fluorescent light bulbs have there is a few disadvantages that must be take into consideration when choosing the correct light system for this project. Because of the electronic ballast, the weight of the bulb is higher than what is desired for this project. Because this system runs on direct current power, finding light bulbs that are not made for alternating current will be hard for the customers. Another problem with the bulb is its size, the light it would make it difficult to close the umbrella. Dimming and turn off this light type can be hard to do with electronics this project has at its disposal. After review the above problems with this lighting system, it is decided that this is not the light bulb to use with this project.

The last type of lighting system that will be review is the light emitting diode. This is a newer type of technology that has revolutionized modern lighting systems. Up to this point the group has considered only gas and filament based lighting systems. Light emitting diode uses a different type of technology. When they first came out in the amount of cost to produce one was far too high, and it saw limited use. As the production matured, the systems started to see use in electronic systems. At this present moment, light emitting diodes are positioned to replace many typical lighting systems around the world. As the name might hint this lighting system is based on the diode technology. As with basic diodes, the light emitting diode has a p and n regions within a solid state body. As

current begins to flow across the boundary, energy is released. This energy is in the form of visible light. Traditionally this light is in the form of a color, not white light. In order to make white light, predominant methods were conceived. The first type to white light production is combining three different types of light colors together to create white light. The three colors that are used are blue, green and red. When these colors are lit up in close proximity to one another they create light that resembles white light. The other method that is used to create white light is using a blue or ultraviolet light emitting diode to and phosphor coating. When the photons from the diode are emitted, it reacts with some of them phosphor to create yellow light. The combination of yellow and blue light creates white light. This process is similar to the way that fluorescent lighting systems work. This type of lighting systems has many advantages that make it a good choice for this project. Because this lighting system is made from electronic components, it will be very easy to control the light emitting diodes. This type of lighting is made from solid state parts, which means that it is less likely to be damaged by shock and falls. Another added benefit to the solid state design is that the system has much long life than the other types of lights review in this section. This means the customer will not have to change the bulbs out during much of the life of the product. They are also very small, which makes mounting them inside the umbrella where they will not be damaged when the unit is closed, very easy. An added benefit to their size is the fact that their weight is virtually meaningless in the overall weight of the project. Another advantage that these lights have is the fact that they are extremely efficient with their energy use. This is a critical aspect of the project design and will benefit the overall project. Most light emitting diodes use very little voltage, which is important to this project. A often overlooked benefit of this type of lighting is that they are ecologically friendly, meaning that no mercury or other toxic compounds are used in the diode. They also are completely recyclable, which means they have the added benefit of not added to the over filling of landfills. Light emitting diodes are not damaged by frequent on and off cycles, this is useful in the dancing mode this project will have. There are a few problems with light emitting diode that the group will evaluate to ensure they will not coincide with the specification listed in section 2.3.3. Because of the way the lights must be weatherproofed, it will be hard for the customer to replace a problem bulb. Light emitting diodes can have high current draw, so this must be taken into consideration if this light system is chosen for this project. Even though there are some issues with this lighting system, it has too many advantages to not be chosen as the primary way to create light for this project. Because current can be an issue, the group must take special care when selecting the correct type of bulb to be used. In order to make sure there is enough light many light emitting diode will be used. The microcontroller will control the lights being used so this will restrict the type of lights chosen.

#### **4.2.2 Product Comparison**

The above section had three main types of lighting systems. Because of all the benefits obtained by using light emitting diodes, this is going to be the type of



bulbs reviewed. In order for the microcontroller to control the light emitting diodes, the operating voltage of the diode must be five volts or less. This is because the microcontroller output is at a voltage of five volts. Another aspect that must be considered when picking a bulb is the amperage. This is important because most light emitting diodes can use a large amount of current. The microcontroller outputs up to forty milliamps. The last thing that the group will review is the amount of light output by the light emitting diode. This is important because the group needs to get the brightest light possible using these given parameters. After reviewing many different types of light emitting diodes the group has compiled a table comparing these values. In Table 4.2.2-1 is the data of the lights being compared.

	YSL-R547W2C-A13	HF5-PW5590	YSL-R1042WC-D15
price	\$0.95	\$0.59	\$0.95
operating voltage minimum (volts)	3.2	3.2	3.0
operating voltage maximum (volts)	3.4	3.5	3.4
operating amperage (milliamps)	20	20	80
Operating temperature range(degree Celsius)	-40-+85	-40-+85	-40-+85
Power consumption (milliwatts)	105	64	180
Color Temperature (Kalvin)	7000	6000	6000
Luminous intensity (millicandela)	9000	5500	18000

Table 4.2.2-1

It is clear from the above chart that the best light emitting diode is the YSL-R547W2C-A13. This is the not cheaper of the all the diodes reviewed by the group but has a much higher luminous intensity and uses little power. This diode has operational amperage of twenty milliamps. Because the output of the controller is forty milliamps current divider is needed. It also has an operational voltage of 3.2 volts. Since the microcontroller outputs five volts, the light emitting diode need to make use of the voltage divider in order to make sure it get the correct voltage. After reviewing the limits of the microcontroller it was decided that his set up would create too much draw and a better way was needed for lighting control. Because this light emitting diode meets all the requirements in section 2.3.3, moving forward this will be the main component behind the lighting system for this project.

## 4.3 Control Units

### 4.3.1 Types and Comparisons

There are three types of control units the Smart Umbrella will take under consideration. They are Application Specified Integrated Circuit (ASIC), Microcontrollers and Field Programmable Gate Arrays. Each unit differs in complexity and design utility and usability. The project will examine all three and choose the best option with accordance to Project Specifications, section 2.3.1 and Controller Specifications, section 2.3.4. The first control unit the design will review is the ASIC.

The Application Specified Integrated Circuit (ASIC) is a microchip that is designed for a fixed product or a specific use. Because the design is so concrete, ASIC's are optimized to perform computational heavy tasks with ease as compared to an FPGA. These circuits are generally used in conjunction with CPUs in a way to accelerate hardware. This is done to add a great bit of functionality without using the majority of the CPU's resources. Examples of the offloads of the CPU would be graphic cards, digital signal processing and floating point processors. So not only are resources saved but tasks are done faster than if the CPU was handling them on its own. Design tools on ASICs have grown in their complexity and are the reason these integrated circuits has grown to go from 5000 gates to over 100 million. Some ASICs has entire microprocessors along with memory blocks such as ROM, RAM EEPROM, and flash memory. The common language for designing these is hardware description language (HDL), like Verilog, to describe its functionality. Because this is a fixed product, manufacturing ASICs can be extremely costly. Products that use ASIC level designs include hand held computers, remote controls, and much more. Types of ASICs are Full-Custom ASICs, Standard-Cell-Based ASICs, Gate-Array-Based ASICs, Channeled Gate Array and many more.

The second control unit the project is considering is the microcontroller ( $\mu$ C). Used in embedded applications that consist of power tools, remote controls, office machines, toys and many more. It can be looked at like a small computer on a single circuit that contains a processor core, programmable input/output peripherals and a small amount of memory. A major draw to using microcontrollers is the ability to handle mixed signals such as analog. Microprocessors are usually embedded in automobiles, telephones, appliances, etc. The programmable I/O pins make this selection desirable due to the variety of peripherals you can add to it. The Smart Umbrella will be using these to be able to support the three sensors, motors, and lights, among other things. Programming these microcontrollers can range between languages. Originally programmed using assembly languages, the complexity of microcontrollers these days are compatible with high-level programming languages. A lot of microcontrollers use their own version of C, such as SDCC. Knowing and learning the language that is compatible with the chosen microcontroller has to be under consideration. Some key microcontroller architectures and vendors are

ARM core processors, Atmel, MIPS, Intel 8051, PowerPC and others. They scale from a 8-bit to 32-bit and sometimes 64 bit architectures. Storing firmware in ROM is also a benefit of using microcontrollers. Because of the flexibility and the amount of peripherals, this would be a great choice.

Lastly the Smart Umbrella will consider the Field Programmable Gate Array (FPGA). The FPGA is different by allowing the customer or a designer to configure how they want after it has been manufactured. The FPGA contains an array of programmable logic blocks and reconfigurable interconnects that tie these blocks together. The programming language is hardware description language (HDL) such as Verilog and VHDL. Many vendors supply the maps of these programmable logic blocks in diagrams. These blocks consists of simple logic gates such as AND and XOR gates and memory which may be flip-flops and complete blocks of memory. Programmable read-only memory (PROM) and programmable logic devices (PLDs) are where the inspiration of the FPGA came from. Originally used in Naval Surface warfare there are a variety of applications that employ the FPGA. Altera and Xilinx are the main vendors of the FPGA. The flexibility that comes with using an FPGA is compared to nothing else currently on the market. The FPGA sacrifices performance and optimization for flexibility on self-configuring. Nothing is set or fixed here like in ASICs. FPGAs can always be programmed to behave like a microcontroller but a microcontroller cannot become an FPGA. Because of the flexibility, costs can change dramatically for the better. The ability to redesign and have nothing fixed can prevent redesign that ultimately effects time and money. Some of the basic applications are medical electronics, high performance computing such as High-end Radars and data mining systems, Audio and Broadcast such as switches and routers and displays. The FPGA is also really great on video and image processing applications which makes it really desirable in companies. The architecture of an FPGA has core components. Logic blocks that consists of a 4-input Lookup table (LUT), a Full Adder (FA) and a D-type flip-flop.

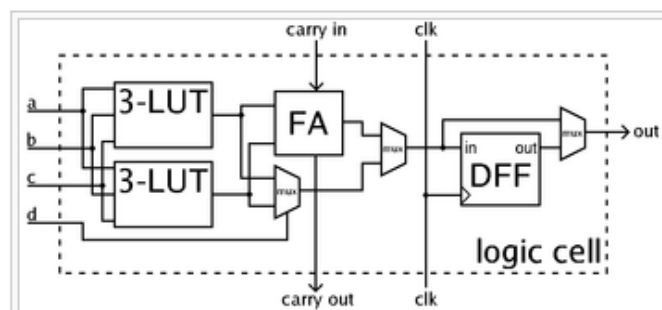

Figure 4.3.1-1  
(Courtesy of Wikipedia)

The architecture of the FPGA also consists of hard blocks, such as multi-gigabit transceivers and hard IP cores such as Ethernet MACs and also consists of clocks. The circuitry inside an FPGA is synchronous with a clock signal. Testing

the code can be done by writing your own test bench to run through the signals to make sure they are properly reading and writing and then using a synchronization tool to make sure the behavioral level code is utilizing the correct amount of gates for optimization. Figure 4.3.1-2 is a block diagram of the ARM Dual Cortex-A9 FPGA

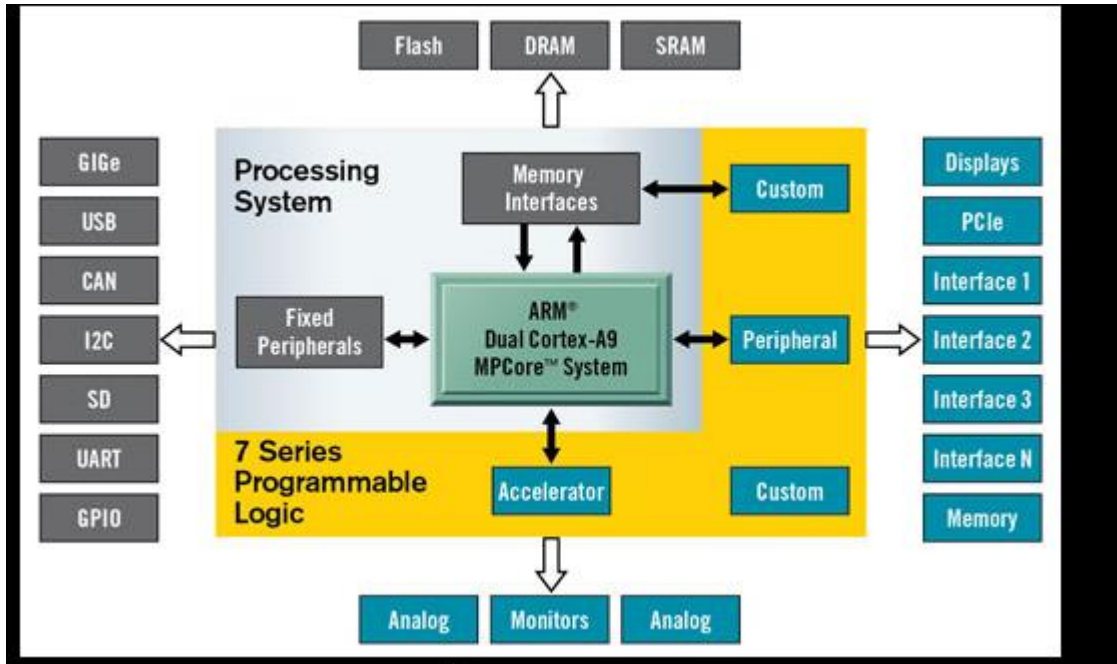

Figure 4.3.1-2 Block diagram ARM Dual Cortex-A9 FPGA  
(Courtesy of Wikipedia)

### 4.3.2 Product Comparison

The Smart Umbrella will get most utilization out of a microcontroller. Referring back to the Project and Controller Specifications in earlier sections the umbrella will be optimized on a microcontroller which consists of 5V, has enough pins to support 3 sensors, motors, LEDs, etc. Has digital and analog Inputs and supports USB capabilities. There are several microcontrollers that also come packaged with an expansion board as well with a bread board. Some also come with resistors and cables. There are a number of microcontrollers on the market that are not expensive that fills these needs. With other concerns this is the best route to go from a simplicity stand point. There are 3 different microcontrollers the project will consider and it will pick the best one that suits the needs of the Smart Umbrella based on performance, efficiency and specification. These are listed in Table 4.3.2-1.

The Smart Umbrella decided on the ATMEGA 2560 due to it meeting all of the specifications of the project. It has enough Digital and Analog pins to support the functions of the umbrella. It has enough memory and runs at an operating voltage of 5 Volts. Other products could be used but would add to additional

costs in the design to make up for what the other microcontrollers had. The cost of the ATMEGA 2560 is low and affordable.

Description	ATMEGA 2560 by Atmel Corporation	R3 ATMEGA 328	ATMEGA 325PA
number of Digital I/O pins	54	14	54
number of analog input pins	16	6	6
Material	gold plate	gold plate	gold plate
power supply	USB / AC-to-DC adapter / battery	USB / Ac-to-DC adapter / battery	USB / AC-to-DC adapter / battery
Operating voltage	5 volts	5 volts	5 volts
input voltage limits	6 volts - 20 volts	6 volts - 12 volts	6 volts - 12 volts
DC current per I/O pin	40 milliamps	40 milliamps	40 milliamps
DC current for 3.3 volt pin	50 milliamps	50 milliamps	50 milliamps
Flash memory	256 KB	32 KB	32 KB
SRam	8 KB	2 KB	2 KB
EEPROM	4 KB	1 KB	1 KB
clock speed	16 MHz	16 MHz	20 MHz
cost	\$32.00	\$11.95	\$23.99

Table 4.3.2-1

The ATMEGA 2560 also has a packaged deal that comes with an expansion board, bread board, 65 DuPont cables, 15 LEDs, five 1K resistors, five 10K resistors, five 220 resistors and a USB cable. With these added bonuses the group felt this was the best choice.

## 4.4 MPPT Algorithms

### 4.4.1 Types and Comparisons

Maximum Power Point Tracking (MPPT) algorithms have changed over the years. To receive maximum efficiency with photovoltaic maximum power point tracking control systems the group will review different methods. One of the original techniques was to compare the photovoltaic array voltage to some constant reference that is near the maximum power point. This is all accurate to specific conditions based on the atmosphere. The difference of this signal, called an error signal is used to drive a power conditioner that interacts with the photovoltaic array to interact with the load. This method doesn't take into account the variations of temperature and irradiation and hence is not the most accurate method. Figure 4.4.1-1 is a block diagram of this method.

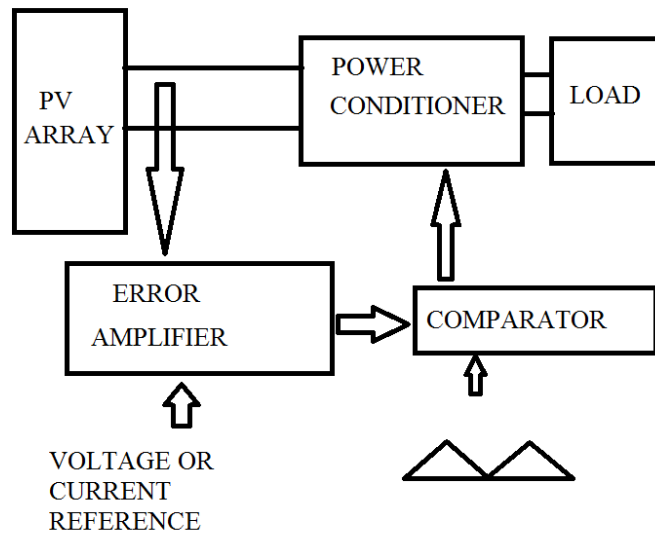

Figure 4.4.1-1 Photovoltaic array vs reference point  
(Courtesy of Types of MPPT Algorithms by Rickey's World)

The next method is a photovoltaic current controlled maximum power point tracking system. In this method the microcontroller calculates a reference current and compares it to the output of the PV array. a DC/DC converter is used in this and the reference current compares to this signal before and after the duty cycle. The PI controller puts on a regulation on the PV current output to become similar to the reference current the microcontroller calculates. Figure 4.4.1-2 shows a diagram for this method.

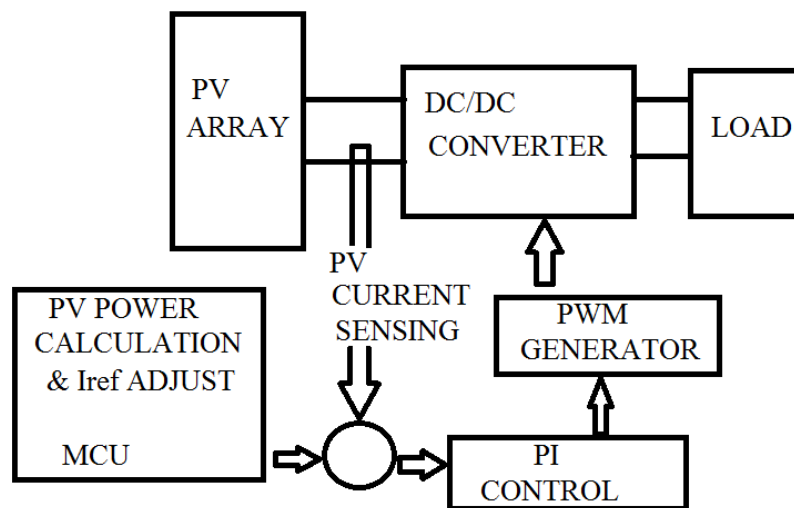

Figure 4.4.1-2 Photovoltaic current controlled MPPT system  
(Courtesy of Types of MPPT Algorithms by Rickey's World)

Another Method that is worth noting is the incremental conductance method. This method is based on the principle that at the maximum power point  $dP/dV$  is equal

to zero. The DC/DC converter puts out a PWM control signal that the PI controller regulates. It does this until  $(dI/dV) + (I/V)$  is equal to zero. The cost is higher in this method due to higher complexity of the control circuit. Figure 4.4.1-3 shows the block diagram for this method.

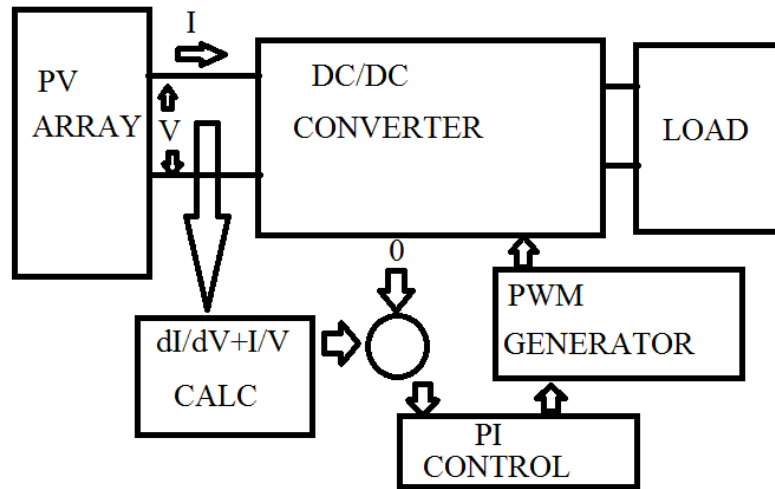

Figure 4.4.1-3 Incremental conductance method  
(Courtesy of Types of MPPT Algorithms by Rickey's World)

Basing off these principles you can assume the DC/DC converter voltage output is constant, hence a feed-forward maximum power point controller can be applied for battery charging applications. This can be used to control the duty cycle of the PWM signal of the dc/dc converter, as shown in figure 4.4.1-4.

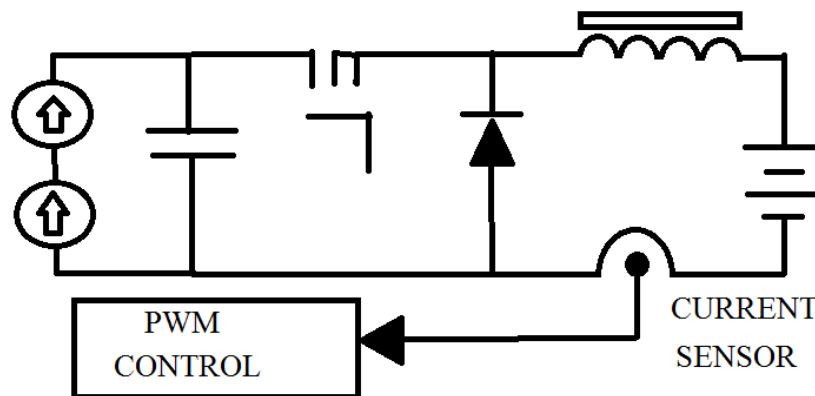

Figure 4.4.1-4 Feed-Forward maximum power point controller diagram  
(Courtesy of Types of MPPT Algorithms by Rickey's World)

By having the power converter controlled by the photovoltaic array power the control algorithm can be based off sampling voltage and currents and the PV

power output. These powers can be calculated by comparing the present and past voltages to be able to gain a reference voltage. The reference voltage is then used to produce the PWM control signal. For a faster response and better stability, the dc/dc converter is driven by a DSP based controller and includes a PI controller which is used to match the results. Figure 4.4.1-5 shows a schematic of this.

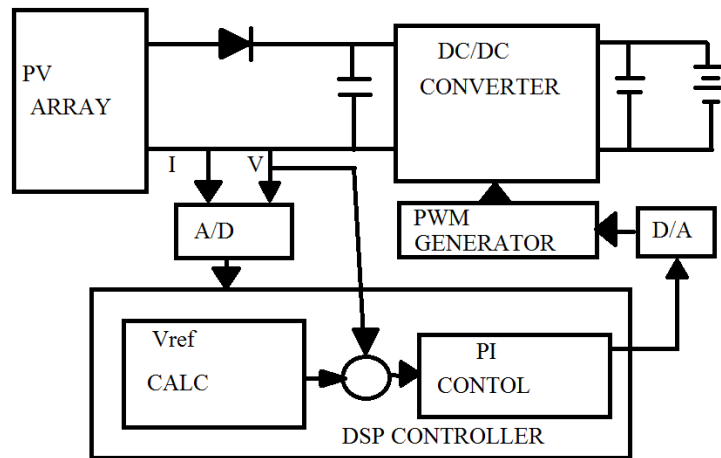

Figure 4.4.1-5 current and voltage sampling method  
(Courtesy of Types of MPPT Algorithms by Rickey's World)

Figure 4.4.1-6 is the MPP tracking algorithm control flowchart.

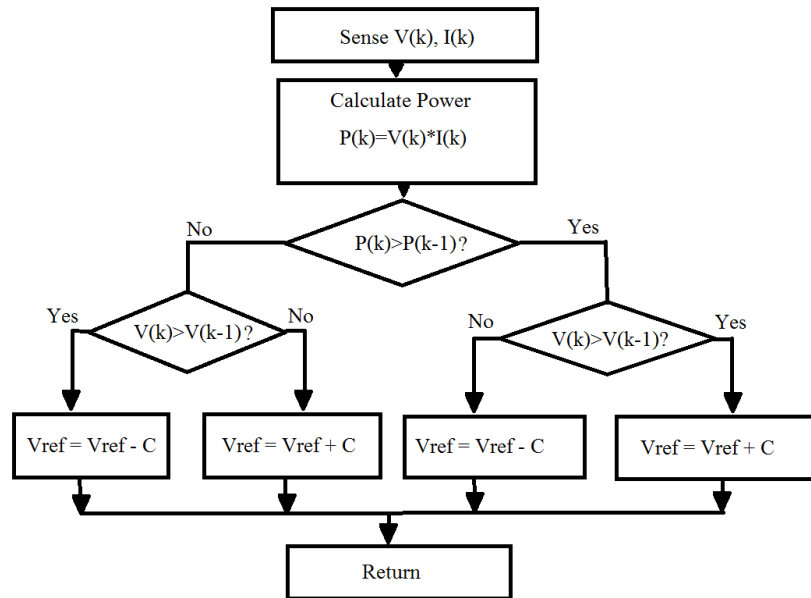

Figure 4.4.1-6 current and voltage sampling flowchart  
(Courtesy of Types of MPPT Algorithms by Rickey's World)



#### 4.4.2 Software Comparison

A method that the group thinks is more suitable to the Smart Umbrella would be to use a Buck-type dc/dc converter to interface the photovoltaic output to the battery to be able to track the MPP of the PV array. This method consists of a switch with multiple parallel connected MOSFETs. This would also consist of a diode, inductor and capacitors. A battery stack would be used with the photovoltaic array load and would differ in current due to a change in atmospheric conditions. This would be a great method to monitor and change the battery charging level and would prevent overcharging. Figure 4.4.2-1 is the MPPT algorithm flowchart for this method. Figure 4.4.2-2 shows the tracking process for this method.

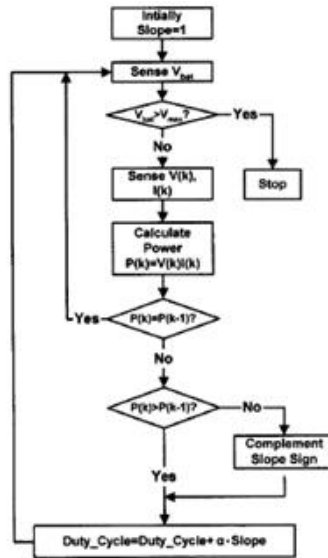

Figure 4.4.2-1 Buck type DC-DC converter flowchart  
(Courtesy of Types of MPPT Algorithms by Rickey's World)

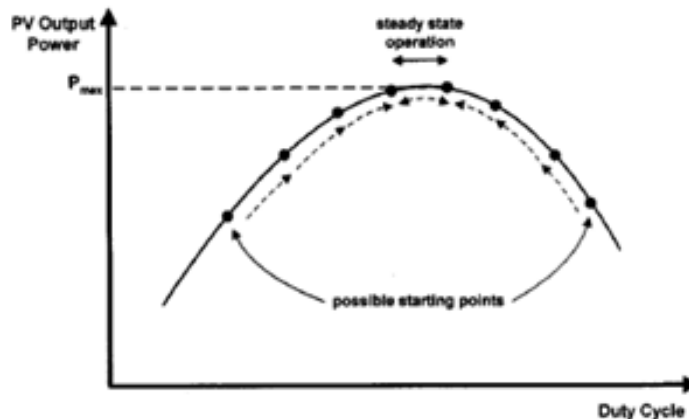

Figure 4.4.2-2 Buck type DC-DC converter tracking process  
(Courtesy of Types of MPPT Algorithms by Rickey's World)

## 4.5 Sensors

### 4.5.1 Voltage Sensors

The Smart Umbrella utilized simple voltage dividers in dividing the voltages to 4 volt analog input when the solar panels reach 12 volts and the battery is at 8.4 volts. This allowed a constant analog signal to be imputed into the microcontroller. These analog signals can then be used to find the maximum power point of the solar panels. The microcontroller can then regulate the output voltage using PWM.

### 4.5.2 Current Sensors

There are many types of current sensors that The Smart Umbrella can utilize. The sensor does exactly what is in the name and that is to measure current, electric current to be exact. The signal that is generated from this current sensor can either be a digital or analog output signal. This current can be used as a measurement in an ammeter or it can be utilized by a microcontroller to run the functions in the project. Current sensors usually consist of 2 inputs, alternating current and direct current. The alternating current can have three different outputs. Analog output, which will be the same wave shape as what the current sensor originally, had as its input. The second is a bipolar output, which also replicates the wave shape of the Current sensors input and lastly is a unipolar output which is proportional to the root mean square value or the average of the current that was sensed. The other type of current input is direct current and this consists of two outputs. The first output is a digital output, which is switched when the current that was sensed exceeds a certain maximum. The second one is unipolar, which is the same as the input wave shape.

Next the design will go over the various technologies associated with current sensors. From the research there are five kinds of methods, the Hall Effect IC sensor, using a transformer or current clamp meter, fiber optic current sensor, resistors and the Rogowski coil. The Hall Effect IC sensor uses the theory of the Hall Effect. It was discovered by Edwin Hall in 1879. The theory states that current consists of the movement of electrons, holes, and ions. When the Lorentz force is created if a magnetic field is present the paths of the collisions of these small charge carriers have curved collisions. Because of this it will leave equal and opposite charges on one side of the face that will limit mobile charges. This will create an electric field that will stop the migration of further charge, so a steady electrical potential is created as long as there is a flowing charge. Figure 4.5.2-1 shows this concept.

Lorentz Force

$$F = qv \times B, \text{ where } F, v \text{ and } B \text{ are vectors}$$

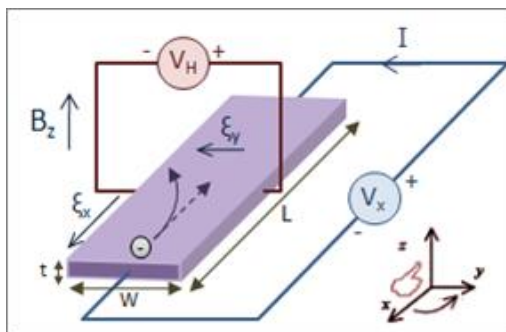

Figure 4.5.2-1  
(Courtesy of Wikipedia)

One sensor that deploys this theory is the Allegro semiconductor integrated circuit. Using this theory it is possible to measure the magnetic field strength to be able to measure current.

The current clamp is a device that employs two jaws that allows clamping around an electric conductor. You can measure the current without having to make physical contact with it. The different types of current clamps are the current transformer, iron vane and a hall effect.

Another current sensor is the Fiber optic current sensor (FOCS). This is a way to measure direct current by employing optical fiber around the current conductor. This method is often used to measure unidirectional or bidirectional DC currents. A benefit to using this sensor as oppose to the others is no calibration is needed throughout its life cycle or after initially being implemented. Because of the optical measurement, it is not affected by magnetic fields. Lastly is a way to just measure alternating current (AC). This method was named after Walter Rogowski and is called the Rogowski coil. The Rogowski coil is a helical coil that has the beginning and ending lead meets so that both terminals are at the same end of the coil. It is then wrapped around the electrical conductor that you want the current to be measured. Figure 4.5.2-2 is a picture of the Rogowski coil.

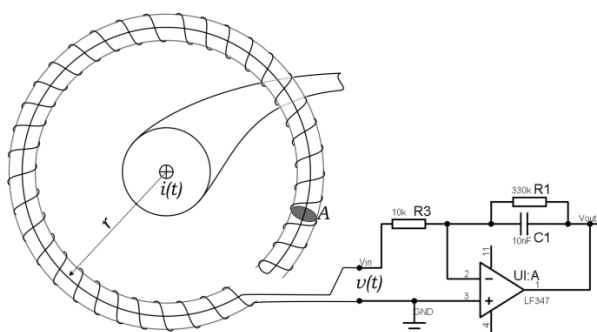

Figure 4.5.2-2 Rogowski coil  
(Courtesy of Wikipedia)

### 4.5.3 Light Sensors

After doing much research on ways to track the sun, the discovery of self-sufficient solar tracking solar panels was an ongoing painful task. A lot of the sensors made for this were built from scratch using a variety of methods. The umbrella will take into account four different methods and will choose the one that will best fit its needs as described in the project specifications and to maximize its efficiency in relaying the sun's position from the made sensor to the microcontroller so it may communicate with the umbrellas motors to align the top of the umbrella to the sun. The umbrella will review all four methods and take into the account the best one based on price, time, effort, and efficiency.

The first method of creating a sensor that can pin point the sun will be using two small thin-film copper indium selenide solar cells. The idea here is to attach these two cells to a triangular wooden block and affix it to the top center of the umbrella top. By adding a voltage divider we can measure the amount of voltage each cell is taking and relay it to the control unit. The microcontroller then can analyze the information and assuming one cell is accumulating more sun (more voltage) than the other, it can send pulses to the motors to adjust the top so each of the two cells are getting equal sunlight.

The next method would be to use light-dependent-resistors (LDR) or also known as a photo resistor. This is a resistor that is controlled by light. The amount of resistance in these resistors decreases as it is exposed to light, meaning it's at its maximum resistance when no sun light is present. Figure 5.3.2-1 below shows a graph of the illumination vs. resistance for photo resistors.

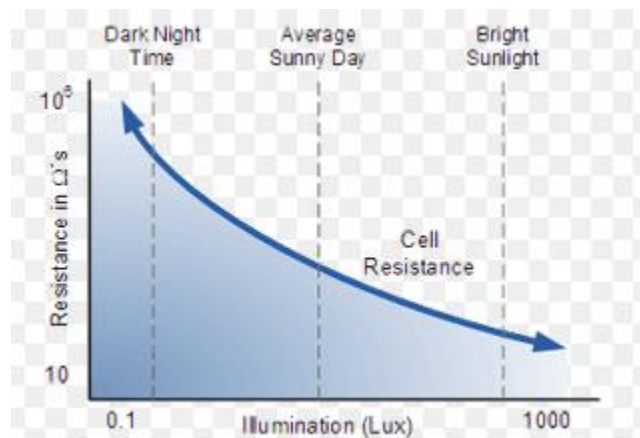

Figure 4.5.3-1 illumination vs. resistance in photo resistors  
(Courtesy of Wikipedia)

We can attach two of these resistors on each end of the top of the umbrella and by including 2 more current sensors we can read the amount of current each of these resistors are outputting. This information can be relayed back to the microcontroller, in which it can communicate with the motors, to ensure the output current on both these resistors is equal.

The next method would be to use the MPPT. By adjusting the motors accordingly we can find the maximum power point that the panels are absorbing from the sun and we can adjust the top of the umbrella from there. This method would force the microcontroller to make adjustments simultaneously and could cause a lot of stress on each motor. As well as causing a lot of stress on the motors, the startup would be difficult to read. This would force the umbrella to do a search on initial set up.

Lastly is to completely avoid using any kind of sensor for pin pointing the sun. The umbrella can use a pre-determined adjustment based on what time of the day it is. This method would take the 360 degree motor out of the purpose and would just be using -45 to 45 degree motor. The microcontroller would communicate with the top motor on a timely basis and would adjust it either on 30 minute to 45 minute increments. This method would need multiple adjustments to account for location in the world as well as keeping track of time of day and time zones.

#### **4.5.4 Product Comparison**

To meet project specifications and to maximize its efficiency, while keeping the cost low we have decided to use light dependent resistors to track the sun in the sky. A special plus shaped shading mechanism was designed using four LDR's, as mentioned in the second method. This allows the readings to be separated into four quadrants. The microcontroller can then easily read which LDR is receiving the most light input and adjust the motors accordingly.

## **4.6 Batteries**

### **4.6.1 Types and Comparisons**

In today's market there is a wide variety of different batteries. There are two major categories in choosing a battery. Primary batteries are disposable batteries that are used only once and then discarded. Secondary batteries are rechargeable batteries that can be used many times. Other parameters for choosing the correct battery for a project range from, size of battery, chemical compound, weight, voltage output, current output per hour, and charging requirements just to name a few. Choosing the right battery for a project is critical in the design process. The battery specifications listed in section 2.3.2 will limit the choice of battery to just a few of these. The four types of batteries that will be considered for this project are the lead acid, Nickel Metal Hydride (NiMH), Lithium Ion (Li-ion), and Lithium Polymer (LiPo) batteries.

Lead acid batteries are commonly used in solar panel applications. These batteries come in two major types. Starting batteries deliver short bursts of high power for starting motors. Deep cycle batteries deliver a low steady rate of power over a longer period of time. For this design, only deep cycle batteries will be considered. Deep cycle lead acid batteries also come in three main categories. These are wet-cell, gel cell, and Absorbed Glass Mat (AGM). The

advantages of using a lead acid battery are very numerous. They are extremely common and make up approximately 40% to 45% percent of worldwide sales. They are cheap in price compared to other battery chemical makeups. They also come in a wide range of voltages and amps per hour ratings. The major disadvantage of using this type of battery in the project, and the reason that these types of batteries were quickly discounted for the design, is the weight of these batteries. Another disadvantage is that these batteries need to be located in an upright position for wet cell. Gel cell and AGM can be used in an upright position and be placed on their sides. Neither type is supposed to be turned upside down. Because of these two major disadvantages, the lead acid battery would not meet the battery specifications listed in section 2.3.2.

Nickel Metal Hydride (NiMH) batteries are also a very common power source in many projects. These batteries have a high energy density (W/kg) and low internal impedance. The life cycle of NiMH batteries is 300 to 500 cycles. They have a flat discharge rate that drops instantly at the end of their cycle. They do not have "memory effects", so discharging the battery fully before recharging is not required. They are lightweight and very durable. This type of battery is very versatile and can be easily placed into packs to achieve desired voltage or current specifications. The cost of these batteries versus the other battery chemical makeups is higher than lead acid, but lower than lithium ion and lithium polymer. This makes NiMH batteries one of the top choices for small projects that require a robust power supply. Because these batteries are the preferred choice for RC cars that require high power output, they are very easy to find. With costs ranging from twenty dollars up to sixty dollars for 7.2v 5000Ahr battery packs. NiMH batteries have few disadvantages. They heat up during charging, which can easily be resolved with venting, and they have a higher leakage current when they are being stored. The precise charging requirements also need to be considered for this type of battery. The NiMH batteries meet all of the design specifications for batteries in section 2.3.2 which makes this a good choice for the project.

Lithium ion (Li-ion) batteries are becoming very popular in high power systems. They have the highest energy density (W/kg) and need no maintenance. They are very lightweight. They can also be configured into packs to achieve desired voltage and current ratings. They have lower discharge rates when storing than the NiMH batteries. Li-ion batteries also have the highest life cycle of 500 to 1000 cycles. They do not have "memory effects" that require them to be discharged before charging. They are relatively easy to find online, but prebuilt packs are not as easy to find as NiMH, in standard part numbers. Li-ion batteries have a relatively flat discharge rate but decrease steadily over time until the end of the cycle where they drop instantly. They have a higher discharge rate than NiMH. The cost of these batteries is twice as much as NiMH and four times as much as lead acid batteries. Lithium ion batteries also meet all of the specifications listed in section 2.3.2 and would also make a good choice for the project.

Lithium polymers (LiPo) are closely related to Li-ion batteries. They can be molded into smaller cell thicknesses. They can also be molded into specific dimensions to meet any design specification. They are lightweight. The disadvantages of these types of batteries are that they are more expensive to manufacture than Li-ion. They also have a higher internal resistance, which limits the current output. LiPo batteries often have lower densities than Li-ion and lower current capacities. Since Li-ion and LiPo are so closely related and the only advantage from switching from Li-ion to LiPo, is the ability to form the battery into special shapes. They will not be considered for the project.

#### 4.6.2 Product Comparison

The brand of battery is important when choosing battery packs. Some inferior brand names have been shown to have lower mAh ratings than advertised. Tenenergy batteries have good reviews and live up to their advertisements. These brands also come in NiMH and Li-ion battery packs in the range of the battery specifications listed in section 2.3.2. Since all battery manufacturers strongly emphasize the need for a Protective Circuit Board (PCB), only battery packs with built-in PCB's will be considered for Li-ion to maintain a high level of public safety. Table 4.5.2-1 compares the top three choices for the project.

	31008 Li-ion 7.4v 6600mAh	31005 LI-ion 7.4v 5200mAh	11228 NiMH 7.2v 5000mAh
total price (shipping included)	\$59.80	\$47.04	\$35.99
weight (lbs.)	0.69	0.46	1
dimensions (inch) (L x W x H)	2.59 x 2.13 x 1.42	2.83 x 2.76 x 0.79	5.9 x 0.9 x 1.8
max charge current (amps)	3	3	2
max discharge current (amps)	6.6	5.2	N/A
cut off voltage over charge protection (volts)	8.5	8.5	N/A
over discharge protection (volts)	5	6	N/A
connector type	bare leads	bare leads	standard tamiya

Table 4.5.2-1

After comparing the 3 choices in table 4.1.2-1, the clear choice to meet the specifications in section 2.3.2 is Tenenergy's 31005 lithium-ion 5200mAh battery pack. This pack is lightweight and durable. The Tenenergy 31005 comes with a built in PCB that protects the battery pack from overcharge and undercharge. This battery pack will need a charging circuit to charge the lithium ion batteries. Lithium ion batteries require a specific constant current and constant voltage

charging cycle. The charger will need to have a temperature sensor to shut down the charging process if the battery pack becomes too hot during the charging cycle. A specific cycle time shutoff is also strongly recommended. Another issue in choosing this battery pack is that it did not fit into the 1.25 inch diameter umbrella pole. Because of this fact, the group decided to build an enclosure using Plexiglas.

## **4.7 Photovoltaic Solar Panels**

### **4.7.1 Monocrystalline and Polycrystalline Solar Cells**

Monocrystalline solar panels, also known as, single crystalline silicon panels, are the most popular type of solar panels on the market today. These types of solar panels make up about 90 percent of the world's photovoltaic needs. They are the most efficient type of panel, with typical ratings around fifteen to twenty percent efficiency. Since they are the most efficient type of panel, they are able to achieve greater power supply over smaller area than the other choices in solar panels. This is the main reason for their popularity. These panels are comprised of the purest silicon, so they are also generally the most expensive type of solar panels. Monocrystalline silicon has to be grown using a process called the Czochralski method. This process is very time consuming and costly, but produces silicon that has all of the silicon crystals arranged in the same direction. They also tend to have a longer lifespan than any of the other solar panels. Another disadvantage to using monocrystalline panels is that they tend to lose performance in higher temperature settings. This performance loss is greater than that of the polycrystalline panels under identical conditions. This technology also has issues with low lighting angles. They can only produce electricity under direct sunlight conditions. Panels can actually stop producing electricity if just part of the panel is covered in shade. This type of panel also tends to weigh more than other types of panels. They are also very brittle and need a strong mounting system to support them. Monocrystalline panels are best used when they can be mounted in a single spot, in direct sunlight, and left to produce power. The weight and durability issues outweigh the efficiency and space advantages for the project, so this type of panel will not meet the specifications in section 2.3.3.

Polycrystalline panels or multi crystalline solar panels are comprised of less pure silicon that can be more easily manufactured. These processes are less costly, because melted silicon can be poured into molds and cooled with a silicon seed. This difference in manufacturing greatly lowers the cost of the panels. This difference also tends to drop the power efficiency of these panels. Generally efficiency ratings tend to range from 13 to 15 percent efficiency. This drop in efficiency means that more area is needed to achieve the same output as monocrystalline panels. These types of panels also have an issue with partial shading of the cell which may result in the whole cell not producing electricity. They are also very brittle and need a very stable and strong support system. Polycrystalline solar panels also tend to lose output when placed in higher



temperature locations, but tend to lose less than monocrystalline panels. Polycrystalline panels also tend to be very heavy and require a rigid mounting system. Again, the disadvantages outweigh the advantages in choosing polycrystalline solar panels for the project.

#### **4.7.2 Thin Film Solar Cells (TFSC)**

Since 2011, this type of emerging technology is growing rapidly in the solar panel industry. Thin film solar cells tend to be less resistant to partial shading than the crystalline types of cells. When part of a cell is blocked by shading, that cell will not completely shut down, but will allow the remaining portion of the cell to continue to produce output. Thin films are better in situations where low angle lighting is an issue. They will produce electricity in a larger wavelength of sunlight which allows them to be closely packed together with less angle mounting. They do not require direct sunlight to produce power. Thin Film Solar Cells are also more resistant to higher temperature settings than crystalline panels. They will produce a relatively steady output at any temperature. These types of cells can be placed on flexible backings which allows for partial bending without harming the solar cell. This factor also makes them extremely lightweight and durable. These advantages are the reason that the thin film technology was chosen in this project.

The two main types of thin film cells that continue to advance in technology are Cadmium Telluride (CdTe), and Copper Indium Gallium Selenide (CIGS). The main disadvantage of using CdTe panels is the environmental issues of using a Cadmium heavy metal that is highly toxic and a proven carcinogenic. They are also dangerous and costly to dispose of or recycle.

CIGS technology, however, uses very little toxic components and has been shown to be the most efficient type of thin film panels. The average efficiency for CIGS is around 13 percent efficiency on flexible backing, though they have been recorded up to 20.4 percent in laboratories. For this project CIGS meets all of the specification requirements listed in section 2.3.3.

#### **4.7.3 Product Comparison**

After weeks of research, no CIGS solar panels could be found that precisely match the specifications for this project. However, individual solar cells were located on eBay. The two types of cells that will be compared will need to be built to create the panel that is needed for the project. The first is from SoloPower. These cells are 1.25 watt lightweight flexible CIGS solar cells. They have a flexible stainless steel backing and produce 0.5 volts max per cell. They have around a 2.65 amp short circuit current. By placing 28 of these cells in series, 14 volts was attainable with an average operating current of 2 amps. These cells are not in any type of weatherproof casing so special consideration was needed when building to make sure that they are encapsulated in a clear lightweight case to maintain their life expectancy. These cells weigh approximately 0.32 ounces. The total weight without casing will be 7.68 ounces (0.48 lbs.). These cells come in two different dimensions so that a choice can be

made on how to uniformly distribute this weight in a visually pleasing setup. These cells meet the requirements for the project which are listed in section 2.3.3. The second types of cells are from Nanosolar. They are a 2.6 watt lightweight CIGS solar cell. They also produce a max voltage of 0.5 volts, with an operating current near 5.2 amps. They are attached to a lightweight aluminum backing and are slightly larger than the Solopower cells. They weigh approximately 0.63 ounces per cell which is almost double that of the Solopower cells, with 24 in series equaling 15.12oz (0.95 lbs.). These cells will also need to be encapsulated in a clear lightweight casing to maintain cell life expectancy. These cells also meet the requirements in section 2.3.3. Since weight is a major constraint in this project to keep the rotating motors small and efficient, The Solopower cells were the obvious choice for this project.

## **4.8 Solar Charge Converter**

### **4.8.1 PWM vs MPPT**

Charge controllers are used between a solar panel and the batteries or load to regulate the output voltage and to protect the batteries from overcharging. Overcharging a battery will significantly reduce the life of the battery and may cause batteries to explode causing harm to consumers or damage to the product. There are two types of charge controllers in the market today. Pulse Width Modulators (PWM) are the oldest type of technology utilized for this purpose. They use DC to DC converters and a voltage sensor at the battery to limit the voltage from the solar panel into a safe charging voltage for the batteries. PWM's do this by using short bursts of higher voltages instead of a constant charging voltage to slowly charge the batteries. When the battery is fully discharged these pulses come at an almost continuous rate, but as the battery becomes more and more charged the pulses begin to taper off. This type of charge controller however is very inefficient. Power is wasted when the batteries are being charged and actually becomes worse as the batteries become fully charged. The Maximum Power Point Tracking (MPPT) charge controller solves this issue. MPPT converters use a microcontroller to track the maximum power output from the solar panels. It then regulates the voltage for a safe charging level for the batteries. Instead of wasting the added voltage, the MPPT will actually adjust this voltage into extra current. It maintains the maximum power output of the solar cells at all times. By continuously maximizing the power output from the solar panels the MPPT charge controller will add approximately 10 to 30 percent more efficiency to the system than a PWM charge controller. It will also maintain a constant charging voltage. For this project a MPPT solar charge converter was designed and built to increase power output while decreasing the amount of solar cells needed. Further details of this charge controller will be discussed in the design portion of this document (section 5.1).

## 4.9 Universal Serial Bus (USB)

### 4.9.1 USB Ports

USB ports are used commonly to charge devices or to interact with the host by transferring data. For this project the USB port will be confined to charging only. There are three types of ports used in Universal Serial Bus or USB for charging purposes. They are Standard Downstream Port (SDP), Charging Downstream Port (CDP), and Dedicated Charging Port (DCP). Most devices are able to read what type of port that they are hooking to based on the circuit configuration of the D+ and D- pins which are shown in figure 4.8.1-1. In all of these ports the "+" pin is connected to a 5 volt supply and the "-" pin is connected to ground. Only the D+ and the D- pins use specific circuitry to allow the device to recognize what type of port it is being connected to.

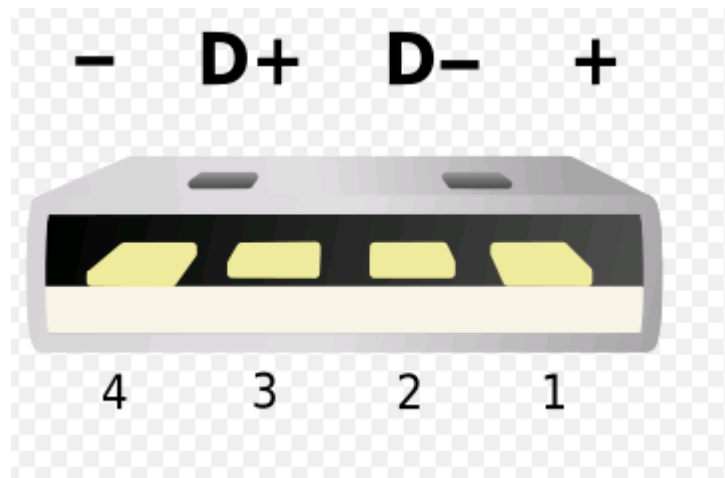

Figure 4.8.1-1 USB 2.0 Type A Connector  
(Reprinted with permission from Wikipedia)

The Standard Downstream Port is used in the USB 2.0 specifications. This type of port is very common and found in most desktop and laptop computers. The USB 2.0 was released in 2000. Its main purpose was to supply power to low powered devices like a mouse or keyboard. The type A Female connector is generally black or white as shown in Figure 4.8.1-2. For a device to recognize the port as a Serial Downstream Port the D+ and D- pins must be separately hooked to a 15k resistor and to ground. This tells the device that is being charged that only 0.5 amps of current are available by the host for charging the battery. To meet the Specifications in the USB Battery Charging Specifications enumeration between the device and host is needed. Because of this restriction and the need for a controlling circuit this type of port was not used in the project.

Since the Standard Downstream Port restricts the max current to 0.5 Amps, another type of port was needed which would increase the output and allow the charging of more power hungry devices. This was the Charging Downstream

Port or CDP. This port allows up to 1.5 amps maximum current output. This type of port is used in USB 3.0 specifications. The type A female connector is usually blue in color to signify to the user that a higher output current is available to the device for charging. This type of port was released in 2008. It was needed to supply power to some of the newer higher powered devices like smartphones and tablets. This port also requires a USB controller IC connected to the D- and D+ pins to determine what type of device is connected to it. This requires more complicated circuitry and will not be considered for this project.

Most wall chargers have access to greater power supplies and thus use the last type of port. This is the Dedicated Charging Port or DCP. This type of port can produce up to a maximum current of 1.5 A for charging laptops or for charging smaller devices more quickly using the increased power output. This type of port uses a, less than 200 ohm resistor, or a short between the D- and D+ pins. This port also does not require any type of enumeration between the host and device. Because of the simple circuitry involved, this is the type of port that will be used in this project.

## 5.0 Project Hardware and Schematics

### 5.1 Maximum Power Point Tracking (MPPT)

#### 5.1.1 Design

In doing the research for the MPPT controller, a similar project was located on instructables.com by deba 168. The group used this design with modifications to design the MPPT for this project. A block diagram of the MPPT design is shown in figure 5.1.1-1. This design utilized a microcontroller to detect and locate the maximum power point and control the output to the load and battery. It does this by using a voltage sensor circuit located at the solar panel along with a current sensor to calculate the maximum power point of the solar panel at all times.

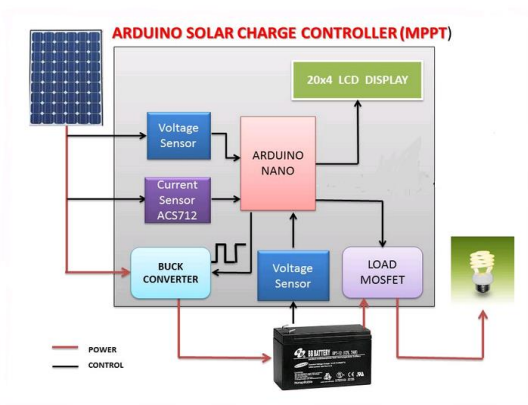

Figure 5.1.1-1 Block Diagram of MPPT  
(Reprinted with permission from deba 168)

This is needed because the voltage of the solar panels will change constantly due to environmental factors. Some of the factors that may cause the power point to change are the temperature of the solar panel surroundings. Since CIGS thin film solar cells were used in the project, the outside temperature will not drastically change the power point, which is one of the reasons that these panels were chosen. Another environmental factor that could change the maximum output of the solar panels is cloud cover or partial shading from some other means. The sun's angle on the solar panels will also affect the power point, but another reason that CIGS solar panels were chosen is because this is less of an issue with these types of panels. Another voltage sensor circuit was located at the battery to read the battery voltage to maintain a constant voltage. The DC to DC buck converter will be controlled by the microcontroller to maintain this constant voltage, which will charge the batteries and run the load. To provide output to the user of what state the battery is in, there are three LEDs that will show the state of battery charging. A small LCD screen also relays needed information on how efficiently the powering system is running.

### **5.1.2 Microcontroller**

The microcontroller needed to be able to take in three analog signals. Two of these analog signals will be from the voltage sensors at the solar panels and at the batteries. The last sensor will be a current sensor at the solar panels. Using a Maximum Power Point Tracking (MPPT) algorithm, the microcontroller tracks the power output from the solar panel and the voltage from the battery. The microcontroller then adjusts the MOSFET driver in the synchronous buck converter. This adjusts the PWM and regulates the output. The microcontroller then uses two outputs to transfer the data from these sensors to the LCD screen. The controller the group chose had enough memory and I/O pins to be able to run the rest of the project. The input power to the microcontroller was hooked directly to the 5 volt regulator to power the board. Initially we believed that the battery pack would run the microcontroller. This voltage ranges from the 7.4 volts supplied by the battery pack to the regulated 8.4 volts supplied by the solar panels. This is within the microcontroller's voltage range. This, however, changed in the final design. The output pins in the microcontroller is 5 volts at a maximum of 0.04 amps. This will limit what can be directly connected to the microprocessor.

### **5.1.3 Synchronous Buck Converter**

In the design of the MPPT, the main component that was designed is the synchronous buck converter. This is a DC to DC converter that takes the variable voltage supplied by the solar panels and decreases the voltage to a steady 8.4v needed to charge the batteries and run the load for the project. The group decided to start off by choosing a high speed MOSFET driver, since this and the microcontroller will be the heart of the converter. The driver that was initially chosen was Texas Instruments LM2722 High Speed Synchronous/Asynchronous MOSFET Driver. The LM2722 was considered primarily because it is specifically designed for use in DC to DC voltage converters. It has very fast switching capabilities, which will increase efficiency in

the design. The LM2722 only requires a 5V input voltage (VCC). This is important because it will require only 1 more DC to DC converter to convert the 8.4 volts from the battery into the 5 volts that will be required by all of the other components in this design. Another important factor in choosing the LM2722 driver is that the output will be 5V (VGS) to the two MOSFETS. The LM2722 datasheet shows a typical design diagram for use as a switching regulator. The group used this diagram to design the circuit for the driver. The two capacitors C1 and C3 in figure 5.1.3-2 are placed between the VCC and GND pins are used for decoupling. They smooth out any imperfections in the VCC input. The IN4148 diode that is positioned between the VCC pin and the CB pin and the capacitor C2 between pins CB and SW in figure 5.1.3-2 make up the bootstrap circuit for increased voltage to the high side MOSFET. The IN pin is used to receive the PWM signal from the controller. This PWM signal will be changing constantly due to the varying power output from the solar panels. The controller will vary this signal to maximize the power which will increase efficiency of the system dramatically. The SW pin, which is the high side driver return, is then hooked to the common node between the high side and low side of the MOSFETS and the inductor L1 as shown in figure 5.1.3-2. The HG and LG pins are the gate drivers for high side and low side MOSFETS. They control the duty cycle of the switching regulator. The MOSFETS that were chosen for the synchronous buck converter, Q1 and Q2 in figure 5.1.3-2, are Texas Instrument's CSD18503KCS 40 volt N-channel NEXFET Power MOSFET. They have a low Drain-to-Source on-resistance of approximately 4.2 milliohms at a 5 volt Gate-to-Source voltage. This low on-resistance decreases the power loss and increases the efficiency of the design. The MOSFET's max voltage of 40 volts with a turn on voltage typically at 1.9 volts is within range of the max voltage from the solar panels (13 volts) and the voltage supplied by the MOSFET driver (5 volts).

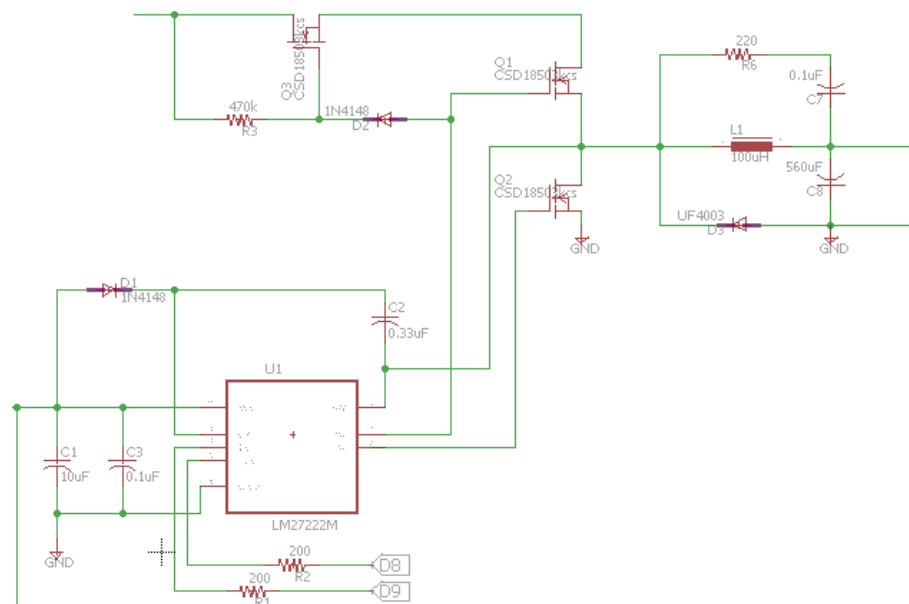

Figure 5.1.3-2 Synchronous Buck Converter Circuit

Though the LM27222 was initially chosen in the design it was later changed due to the difficulty of prototyping on the breadboards. Instead the group decided to go with International Rectifier's IR2104 which came in a DIP8 packaging and made prototyping on the breadboard much easier. Once the decision was made to switch to the IR2104, substantial progress was made in getting the MOSFETS to switch properly. Figure 5.1.3-3 shows the final Eagle schematic that was used in the design using the IR2104 MOSFET driver.

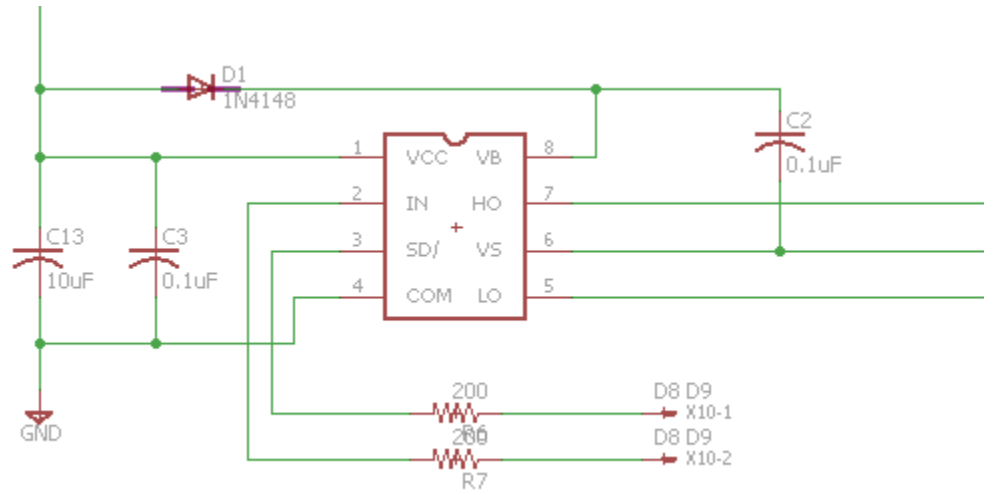

Figure 5.1.3-3 IR2104 MOSFET Driver

The configuration of the IR2104 is similar to the LM27222 design, but the IR2104 made troubleshooting much easier. The main difference between the two is the fact that the IR2104 needed an input voltage that was between 10 to 20 volts. This was accomplished by hooking VCC directly to the solar panels. This also created a minimum solar panel voltage of near 11 volts before MOSFETS would open. This insures that the charging IC will get at least 11 volts making sure that it is not running at a 100% duty cycle, which lengthens the life of the design.

The next component that needed to be selected for the buck converter was the inductor size, L1 in figure 5.1.3-2, and the inductor saturation current. The size of the inductor in a buck circuit is determined largely from the switching frequency of the MOSFETS. Larger switching frequencies allow a smaller inductor, but will also decrease the efficiency of the system due to higher switching losses in the MOSFETS. Since efficiency is extremely important in this design a lower switching frequency of 62.5 kHz was chosen. Because the solar panels were constructed from individual cells the max voltage ( $V_{in}$ ) will be approximated at 14 volts, which is 0.5 volts per cell times 28 cells. The output voltage ( $V_{out}$ ) will be 8.4 volts due to the overcharge protection of the battery at 8.5 volts. The Duty Cycle can then be approximated using equation (1) at  $D = 0.6$ .

$$\mathbf{Duty\ Cycle\ (D) = V_{in} / V_{out}} \quad \mathbf{equation\ (1)}$$

To maintain a decent output performance, a target ripple current of 20% to 40% of rated output current is suggested. By choosing a value of the ripple current of 30% of the rated current of 2.5 amps and using equation (2), the ripple current can be calculated.

$$\mathbf{\Delta I_L = 0.3 \times I_{rated}} \quad \mathbf{equation\ (2)}$$

This gives a  $\Delta I_L$  of 0.75 amps. Using equation (3), the minimum inductor can then be calculated.

$$\mathbf{L_{MIN} = ((V_{in} - V_{out}) \times D) / (\Delta I_L \times F_{sw})} \quad \mathbf{equation\ (3)}$$

After calculations this value is 67uH. This is the minimum value of the inductor needed for this application. The saturation current will also need to be calculated using equation (4).

$$\mathbf{I_{sat} = I_{rated} \times (\Delta I_L / 2) \times (0.2 \times I_{rated})} \quad \mathbf{equation(4)}$$

For most inductors there is a tolerance level of  $\pm 20\%$  that is added to the inductor sizing. So a minimum of 80uH inductor with a minimum saturation current of 3.3 amps is needed for this design. An inductor with the smallest DC Resistance (DCR) will also help maximize the efficiency of the system. J W Miller's 5505-RC high current choke inductor has an inductance of 100uH with a  $\pm 20\%$  tolerance. They have a low DCR of 0.061 milliamps to maintain efficiency, with a maximum current of 4.9 amps. These specifications are well within the range calculated above.

The next step in creating the buck converter will be choosing the capacitor. The capacitor is needed to maintain a steady voltage when the high side MOSFET is off. Since the load current will be adjusted frequently, this capacitor will also need to minimize any voltage overshoot from sudden current changes in the load. The LI-ion battery charging protection circuit is rated at 8.5 volts max input voltage. This allows a 0.1 volt difference before the overvoltage protection on the protection circuit shuts down the charging to the battery. This allows the maximum output voltage overshoot to be 0.1 volt. Using equation (5), the minimum capacitor can be calculated at 440 uF.

$$\mathbf{C_{min} = (L \times I_{peak}^2) / ((V_{ripple} + V_{out})^2 - V_{out}^2)} \quad \mathbf{equation\ (5)}$$

This allows a transient voltage spike of up to 1.5% of the 8.4 volts and a ripple voltage of 0.126 volts. This result keeps the maximum voltage confined to near 8.5 volts and insures that the overprotection device on the battery charger will not be triggered with sudden current changes from maximum load to no load conditions. This also means that a very low Equivalent Series Resistance (ESR)



will be needed for this capacitor. The maximum ESR can be calculated by taking the ripple voltage and divided the maximum current. This gives a max ESR of 0.05 ohms. Adding 20% to the 440 uF for non-ideal components will insure a proper sized capacitor for the circuit and raise the capacitance needed to a minimum of 528 uF. Panasonic's radial lead capacitor EEU-FC1A561 is a 560 uF with an ESR of 0.117 ohms. This capacitor also has a max voltage of 10 volts. This product will fit the values calculated above.

The high speed diode UF4003 that is in series with the capacitor in figure 5.1.3-2, is used to control the current flow from the inductor when the high side MOSFET is off. Without this diode the current would continue to flow across the inductor increasing the voltage at the MOSFET's. This diode allows a path for the current to flow thus maintaining the voltage at the MOSFET to a safe limit. There is a RC snubber circuit, R6 and C7 in Figure 5.1.3-2, also in parallel with the capacitor. This helps reduce the ringing of the inductor voltage due to current changes in the inductor.

This part of the circuit also uses a third MOSFET, Q3 in Figure 5.2.3-2 to efficiently block the battery from flowing back into the solar panels. This decreases the stress on the panels and also allows the battery to be used only on the loads when the solar panel is no longer producing power. The 470 kohm resistor and diode, R3 and D2 in Figure 5.1.3-2, only allow the MOSFET to be switched on when the high side gate of the buck converter is switched on. This can also be done using a simple diode, but using a diode for this purpose decreases the voltage into the buck converter as a turn on voltage is required. By using this configuration, the voltage is maintained at maximum levels thus increasing system efficiency.

#### **5.1.4 Current Sensor**

The current sensor is used in the design of a MPPT converter to measure current coming from the solar panels so that the maximum power point can be determined by the microcontroller. Figure 5.1.4-2 shows the current sensor circuit.

Allegro's Fully Integrated, Hall Effect-Based Linear Current Sensor IC with 2.1 kVRMS Isolation and a Low-Resistance Current Conductor part number ACS712ELCTR-20A-T was chosen for this project. It requires only a 5 volt input voltage. This sensor reads the current coming through it and produces a voltage analog signal for continuous reading from any current changes due to changes in solar panel voltages. The analog signal can be used by the microcontroller to continuously and accurately calculate the maximum power point. Pins 1 and 2 are connected to the input from the solar panels. Pins 3 and 4 are connected to the output going to the buck converter. Pin 6 is used to regulate the frequency bandwidth by using a capacitor, C5 in Figure 5.1.4-2, which is connected from Pin 6 to ground. Pin 5 is also connected to ground. Pin 7 is the analog signal that goes to an analog input on the microcontroller. Pin 8 requires a 5 volt input voltage and is also connected to a capacitor, C10 in Figure 5.1.4-2, that helps stabilize the input voltage.

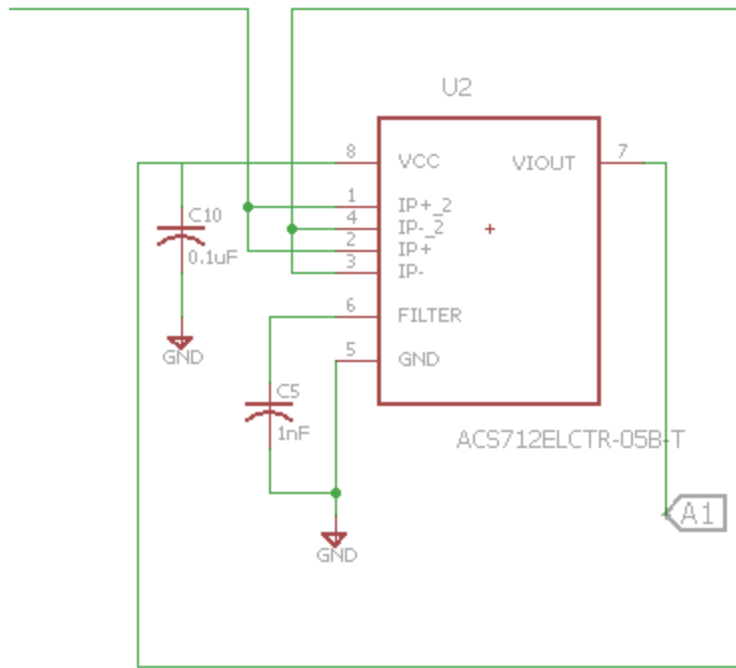

Figure 5.1.4-2 Current Sensor Circuit

### 5.1.5 Voltage Sensor

Two voltage sensors were needed in the design of the MPPT converter. The simplest way to implement these sensors was to use a voltage divider as shown in Figure 5.1.5-1.

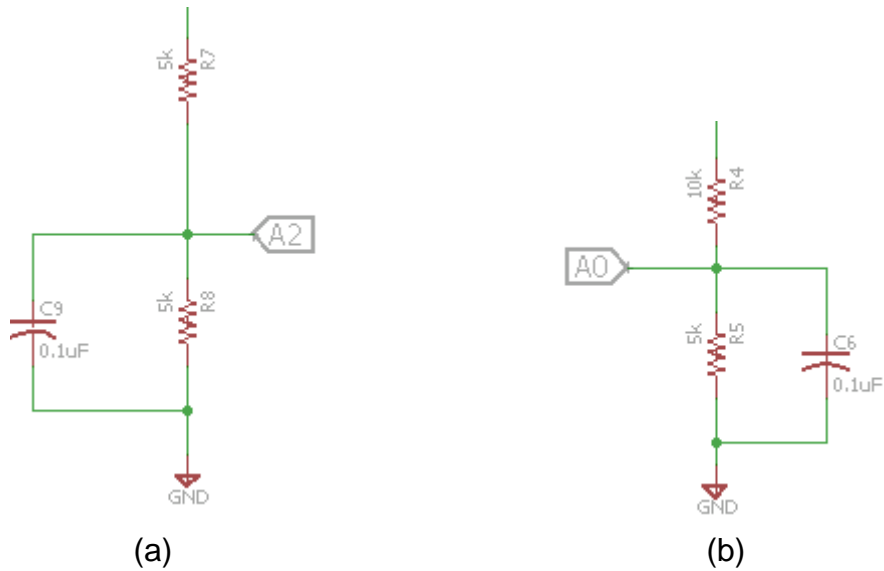

Figure 5.1.5-1 (a) Battery Voltage Sensor (b) Solar Panel Voltage Sensor

The first sensor is needed to calculate the voltage at the solar panels. The second sensor is used to calculate the voltage at the battery. The input voltage from the solar panel is 14 volts with a desired output going to the microcontroller of 4 volts. The input from the batteries is 8.4 volts with a desired output to the microcontroller of 4 volts. The resistors were calculated using these values. The maximum input of the microcontroller is 5 volts so this will allow for a small increase in solar panel and battery voltage if needed. These circuits will also produce a continuous signal to the analog input of the microcontroller. This will allow the microcontroller to continuously and accurately determine the maximum power point and maintain a constant 8.4 volts to the battery and load. The capacitors, C6 and C9 in Figure 5.1.5-1, help to stabilize the voltage signal going to the microcontroller.

### 5.1.6 Load MOSFET

This portion of the circuit is hooked to the buck converter in section 5.1.3. It consists of a 5 amp fuse going to the load to make sure the current isn't too large, which may damage components of the circuit. The MOSFET Q4 in Figure 5.1.6-1 is driven by a transistor, T1 in figure 5.1.6-1. This transistor can be regulated by the microcontroller to turn on when sufficient power to the load is supplied.

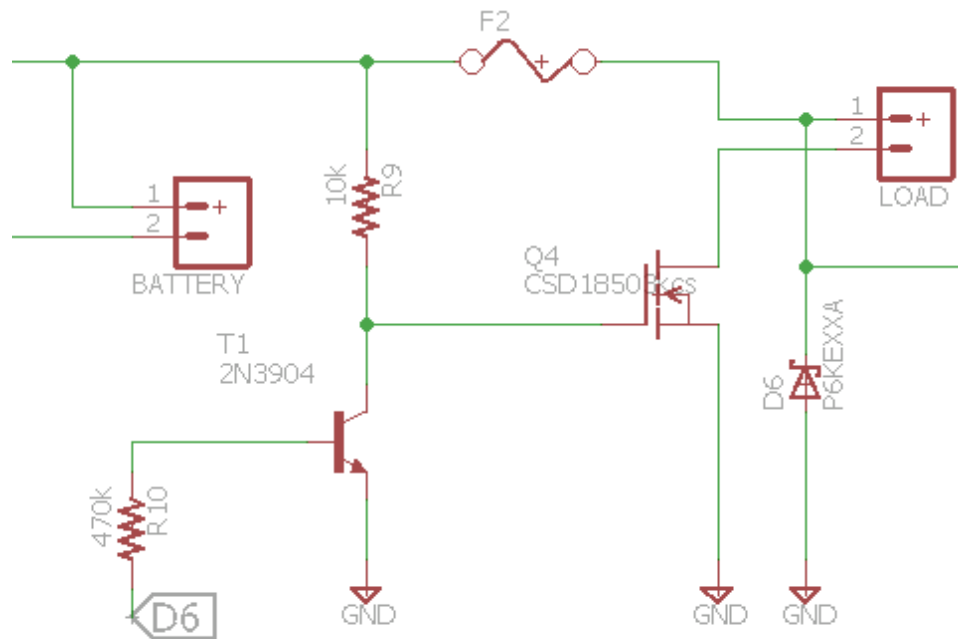

Figure 5.1.6-1 load MOSFET circuit schematic

There is also a TVS diode, D6 in figure 5.1.6-1, which is placed in the circuit to remove any transient voltage spikes from the load. Circuit was designed, but ended up not getting added in the final design due to the need to simplify the MPPT PCB. The Final design deleted the load MOSFET from the PCB.

### 5.1.7 LCD Display

A simple 20x4 LCD screen was utilized in the project to display the MPPT charging information. The IIC 12C TWI SPI serial INTERFACE2004 20x4 Character LCD Module Display Yellow was chosen for the project. Figure 5.1.7-1 shows the circuit for this screen. Pin 4 is hooked to a 5 volt supply. Pins 3 and 4 will go to the microcontroller for interfacing. Pin 1 is a ground. This display will show vital information from the solar panel, the battery, and the load.

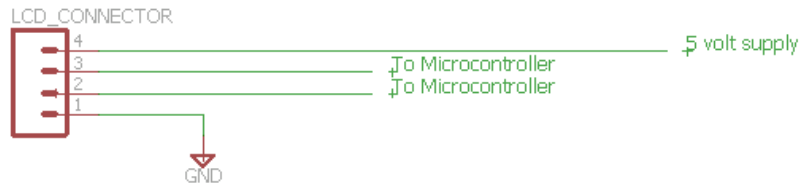

Figure 5.1.7-1 LCD screen circuit schematic

A simple push button switch was added on the outside of the packaging box where the batteries and circuitry were housed for lighting up the display when needed. This will increase efficiency of the project because the display will not use power by staying lit continuously. The LCD screen displays the solar panel voltage output, current output and total power output. It also displays battery voltage and the PWM.

## 5.2 Power System Design

### 5.2.1 Battery Charging Design

Lithium Ion charging systems require a very detailed charging system to keep battery conditions at a safe level. Figure 5.2.1-1 shows a typical charging profile for this IC. The right charging system will increase the life of the battery and also will decrease the likelihood of the battery rupturing which may cause damage to consumers or to the product in which they are installed. Since Tenergy's 31005 lithium-ion 5200mAh battery pack was chosen for the project, special detail had to go into the charging system. After much research, a decision to use Texas Instrument's SINGLE-CHIP SWITCHMODE, LI-ION and LI-POLYMER CHARGE MANAGEMENT IC WITH ENHANCED EMI PERFORMANCE model number BQ24123RHLR was chosen to maintain a safe charging system.

The charging profile in Figure 5.2.1-1 shows why charging lithium Ion batteries is so difficult. When a lithium ion battery is over discharged there is a precondition phase which trickle charges the battery very slowly. This slowly increases the voltage of the battery pack to the minimum charging voltage. The battery pack that was chosen came with a built in under voltage shutoff circuit to decrease the likelihood of this happening thus decreasing the time needed to fully charge the battery pack to maintain efficiency of the project. Once this minimum charge voltage is reached, the charging system then will increase the current input to a



An 8.4 volt supply directly from the synchronous buck converter runs the BQ24123RHLLR IC. This input has a 10 uF capacitor, C13 in Figure 5.2.1-3, to smooth out the voltage to the chip. The IN1 and IN2, which are pins 3 and 4 in Figure 5.2.1-3, were directly hooked to the 8.4 supply voltage. Pin 2 was directly hooked to an LED which is in series with a 1.5k ohm resistor, R11 in Figure 5.2.1-3. This Led will turn on when the battery is being charged. To separate this LED from the other indicator LED's that will be used, the group decided on using a green LED to signify the battery charging status. Pin 19 is also directly hooked to an LED light in series with a 1.5k ohm resistor, R12 in Figure 5.2.1-3. This LED will be yellow in color and will signify that the battery is fully charged. Pin 5 will be hooked to another LED in series with a 1.5k ohm resistor, R13 in Figure 5.2.1-3. This LED will be red in color and will show that there is a valid supply voltage to the chip. These three LED's were placed in the packaging box beneath the LCD screen to further allow the user to easily see the charging status of the battery. Pin 7, the TTC pin, is hooked to a 0.1uF capacitor, C12 in Figure 5.2.1-3. This pin is used for the timer and termination control. This is an added feature that will terminate the charging cycle at a designer's set time limit. This is a backup safety feature that restricts the amount of time that the battery can be charged. By placing a 0.1uF capacitor to ground on this pin the charging time will be restricted to a maximum five hour charging cycle before being shut down. Pins 16 and 18 in Figure 5.2.1-3, the CE and VSS pins will both be connected directly to the ground of the system. The CE pin can be used to control the integrated circuit from an external control unit. By hooking this directly to ground, this integrated circuit becomes a stand-alone circuit that needs no external control system. Pin 13 the CELLS pin is used to signify the number of cells being charged in the battery. Hooking this pin directly to the 8.4 volt supply voltage will cause this chip to output 4.2 volts for 1 cell battery chargers. By placing a 10k resistor, R16 in Figure 5.2.1-3, between Pin 13 and the supply voltage, the output will increase to 8.4 volts to charge a 2 cell battery pack. Pins 1 and 20, the two out pins will be connected together to a transient voltage suppressor diode, D8 in Figure 5.2.1-3, this will remove any transient voltage spikes from the system. These two pins will also be hooked to a 10uH inductor, L2 in Figure 5.2.1-3. This inductor will be hooked to a 10uF capacitor to ground, C15 in Figure 5.2.1-3, and to a 0.1 ohm resistor, R22 in Figure 5.2.1-3, before going to the positive terminal of the battery pack. This combination inductor, capacitor, resistor tell the integrated circuit at what current rate the battery pack will be charged at. Using the configuration explained above sets the current output to 1 amp of charging current. Pins 17 and 18 the PGND pins are hooked to ground. Pin 15, the SNS pin, is a charge current pin. This will be connected before the resistor R22 and will sense the voltage drop across this resistor to be able to regulate the current output to 1 amp. This pin will also be connected to a 10uF capacitor, C16 in Figure 5.2.1-3, to ground. Pin 14 will be hooked directly to the positive terminal of the battery pack. Pins 8 and 9 will be separately connected to two 7.5k ohm resistors, R18 and R19 in Figure 5.2.1-3, then to ground. Pin 12, the TS pin is used as another safety feature provided by this integrated circuit. It is hooked through a voltage divider, R19 and R20 in Figure

5.2.1-3 then to a 103AT thermistor that will turn off the circuit if the temperature of the batteries becomes too hot. R20 will then be hooked to ground. R19 will be connected to pin 11 the VTSB pin. This pin is the internal bias regulation voltage for the TS pin. The VTSB will also be connected to a 0.1uF capacitor, C14 in Figure 5.2.1-3. This chip also has an external thermal pad. This pad requires that the same ground used in Pin 10 be used to ground the exposed pad. If installing on a PCB board, this will need to be soldered to the ground plane.

### 5.2.2 USB Charging Design

The simple circuit below was used to charge low powered devices like cell phones. This circuit has a regulated 5 volt power supply. Adding a 10 ohm resistor, R15 in Figure 5.2.2-1, regulated the current output to 0.5 amps. This will ensure that the user cannot charge a larger powered device that may drain the battery or consume the maximum amperage from the solar panels. The D+ and D- pins were separated with a 100 ohm resistor, R14 in Figure 5.2.2-1 this will allow any device hooked to the circuit to know that this is a Dedicated Charging Port (DCP).

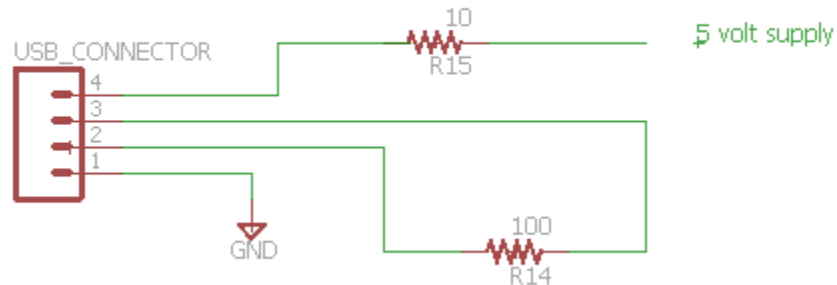

Figure 5.2.2-1 USB Circuit

This will be enough to charge most cell phones in a couple of hours or to maintain a charge if the user is using the phone. This simplistic design will not charge all phones. Some phones like the Apple series will not recognize this configuration. This is because these phones restrict the user to using their specific charger to charge their phones. To add this type of charging capability a USB charging IC would need to be implemented in the design. This detail may be considered at a later date to increase the functionality of the design. This will also increase the cost of this circuit.

### 5.3 Controller System Design

The microcontroller used in this design is the ATmega 2560 made by Atmel. It is a lower power microcontroller that is CMOS 8-bit and is based on a AVR enhanced RISC architecture. By maximizing its throughput approaching close to 1 MIPS per MHz, this microcontroller chooses to optimize power consumption versus its processing speed. The rich instruction set is combined with 32 general

purpose working registers that is directly connected to the Arithmetic Logic Unit (ALU) that can gain access to two independent registers in one instruction, all this is executed in one clock cycle making the architecture more code efficient. This specific model is comprised of 256 KB In-System Programmable Flash with Read-While-Write capabilities. It has 4 KB EEPROM, 8 KB SRAM and runs at a clock speed of 16 MHz. With the 86 general purpose I/O lines and 16 Analog Inputs this model has more than enough to run the Smart Umbrella. The ATmega 2560 also comprises of twelve 16 bit resolution PWM channels, 4 serial USARTs and 16 ADC channels. Figure 5.3-1 is a block diagram of the AVR CPU.

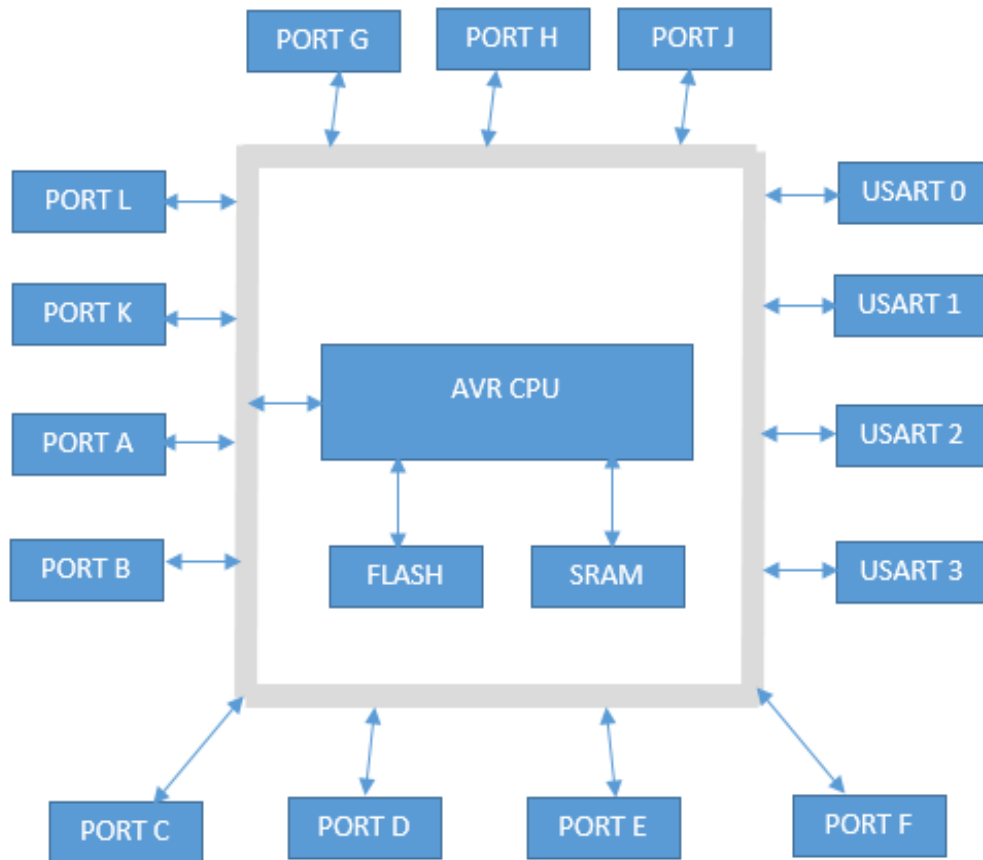

Figure 5.3-1 AVR CPU block diagram

Ports A, B, C, D, E, H, J and L are 8 bit bi-directional I/O port equipped with an internal pull-up resistor. Each of these ports is tri-stated when a reset condition becomes active. Port F also serves as an 8-bit bi-directional only if the A/D Converter is not used. Port F also holds the functions of the JTAG interface. Port G is only a 6-bit I/O port and port K serves as the analog inputs to the A/D Converter.



Other pins not listed in Figure 4.3-1 are listed in Table 5.3-1 below.

Pin Name	Description
VCC	Digital supply voltage
GND	Ground
RESET	Reset input. If there is a low level on this pin for longer than the minimum pulse length, a reset will occur
XTAL1	Input to the inverting Oscillator amplifier. Input to the internal clock operating circuit as well
XTAL2	Output from the inverting Oscillator amplifier
AVCC	Supply voltage pin for the port F and the A/D Converter. Externally connected to Vcc. Should be connected to Vcc through a low-pass filter if the ADC is used
AREF	The A/D Converter analog reference pin

Table 5.3-1 Pin List

The main ports in the diagram also have various special features of the ATmega 2560. Each of these features were vital to running the design and utilizing all of the capabilities of the microcontroller. Understanding the AVR CPU core architecture is key to understanding how to guarantee correct program execution. CPU tasks include, accessing memory, control peripherals, perform calculations and deal with interrupt handling. Figure 5.3-2 is a block diagram of the AVR architecture.

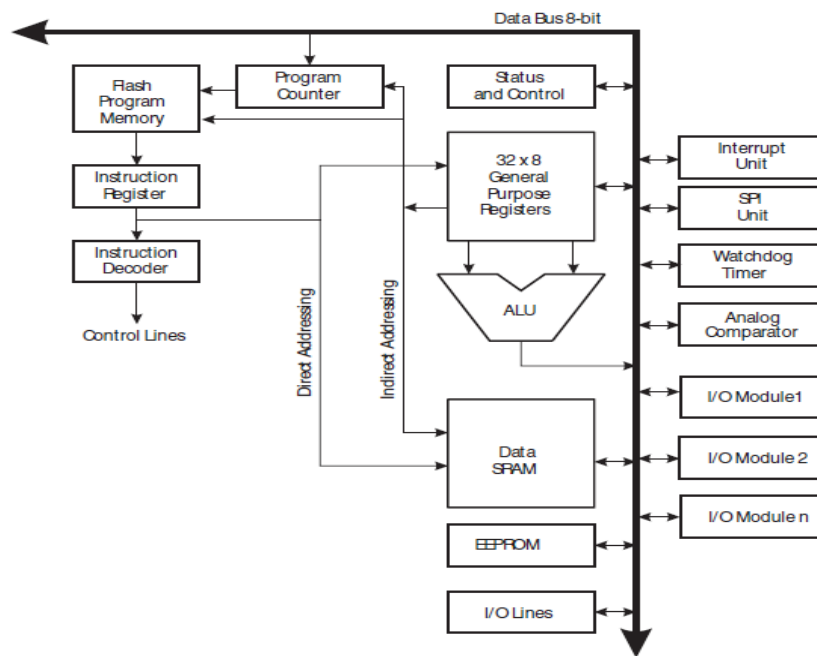

Figure 5.3-2 AVR Architectural Block Diagram  
(Courtesy of AVR Architecture by AVR)

The architecture is based off the Harvard architecture, with separate memories and buses for program and data. The instructions are executed using single level pipeline architecture. To fetch an instruction per clock cycle, the next instruction is pre-fetched from the memory while the current instruction is being executed. The register file contains thirty-two 8-bit general purpose working registers that has a single clock cycle access time. The Arithmetic Logic Unit can then operate in one clock cycle. Six of the 32 registers can be used a three 16-bit indirect address register pointers for the Data Space addressing to be able to have efficient calculations of the address. The program flash memory space is also divided into two sections, the Boot Program section and the Application Program section.

The input/output memory space contains 64 addresses for CPU peripheral functions such as Control Registers, SPI, and other I/O functions. The status register is key to understanding what the last arithmetic instruction that was executed by the ALU. Understanding the status register is vital in altering the flow of the program to perform conditional operations. Table 5.3-2 shows how the status register is read from the least significant bit.

7	6	5	4	3	2	1	0
I	T	H	S	V	N	Z	C
R/W	R/W	R/W	R/W	R/W	R/W	R/W	R/W

Bit	Name	Description
7 / I	Global Interrupt Enable	Must be set for interrupts to be enabled
6 / T	Bit Copy Storage	Uses as source or destination for the operated bit
5 / H	Half Carry Flag	Half carry in arithmetic operations. Useful in BCD arithmetic
4 / S	Sign Bit	Always an exclusive or between the Negative Flag N and the Two's complement Overflow Flag V.
3 / V	Two's Complement Overflow Flag	Supports two's complement arithmetic
2 / N	Negative Flag	Indicates a negative result in an arithmetic or logic operation
1 / Z	Zero Flag	Indicates a zero result in an arithmetic or logic operation
0 / C	Carry Flag	Indicates a carry in an arithmetic or logic operation

Table 5.3-2 SREG Description

Also vital to knowing is the AVR CPU general purpose working registers addresses; knowing the Register File. Since most instructions have direct access to every register in the Register file, they are single cycle instructions. The

registers are mapped in the first 32 locations of the Data Space. The X, Y and Z pointers can be set to index any of the registers of the file. Figure 5.3-3 is a diagram of the register file displaying all 32 registers and their address.

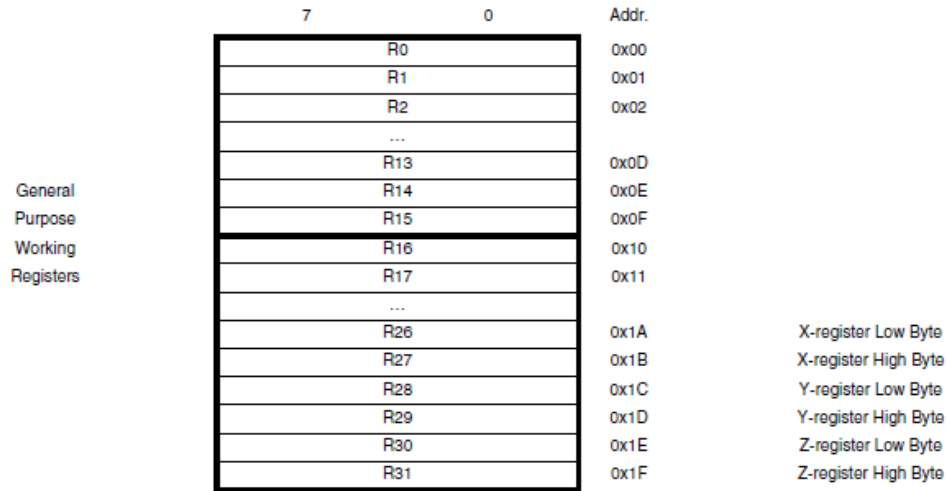

Figure 5.3-3 Register File  
(Courtesy of AVR Architecture by AVR)

Now that there is an understanding of the AVR Core and Architecture of the Atmega 2560, diving into the design aspect will be easier. Port K will have the analog pins that will take in the input from the 2 voltage sensors and the one current sensor. The Umbrella will use any of the ports that house the 8-bit I/O pins to communicate with the LEDs on top of the umbrella, and we have a variety of other ports to choose from to be able to communicate with the MPPT and Motors. Figure 5.3-4 is a block diagram of microcontroller and its interfaces.

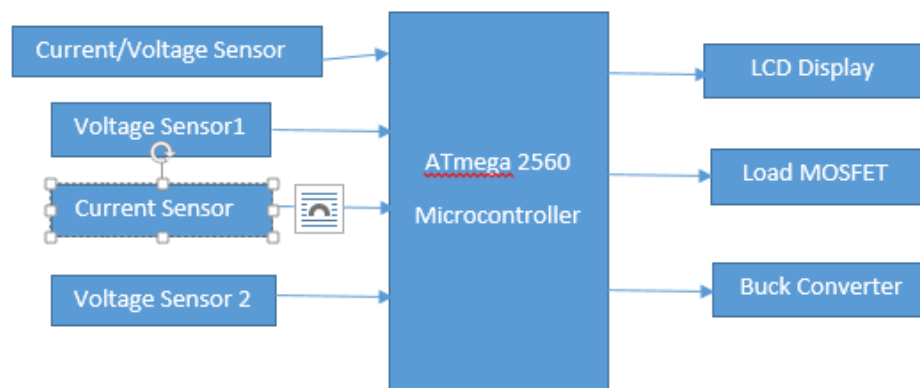

Figure 5.3-4 Design Block Diagram

Voltage Sensor 1 and Current Sensor 1 will input from the solar cells on top of the umbrella. Input Voltage can be anywhere between 6 - 13 Volts. Voltage Sensor 2 is an input coming from the battery and will be 6 - 8.4 Volts. The

current/voltage sensor can vary due to which sun tracking method we go with. The outputs of the ATmega 2560 will be 5 volts and will go to the LCD display screen which will display readings of voltages from the battery, MPPT and solar cells. The second 5 volt output will go to the motor controllers. And the last output will be a 5 volt signal going to the Buck Converter which will operate the MPPT to ensure at least 90 pct. efficiency.

## 5.4 Lighting Design

The LED lights for this project have a couple of different functions. They provide normal light for activities at night. They also provide an entertainment phase that is controlled by the microcontroller. Since the maximum output from the microcontroller pins is 40 milliamps, only a max of two LED's can be connected to the microcontroller. After looking at how much current would be drawn from the microcontroller, the group decided to use the battery to driver the LED directly. In order to do this it was necessary to have an interface device between the microcontroller and the LEDs. This is where the LED driver comes into the picture. The picture in Figure 5.4-1 shows LED driver used for this project. It is an Adafruit 24 channel pulse width modulation LED driver model number 1429.

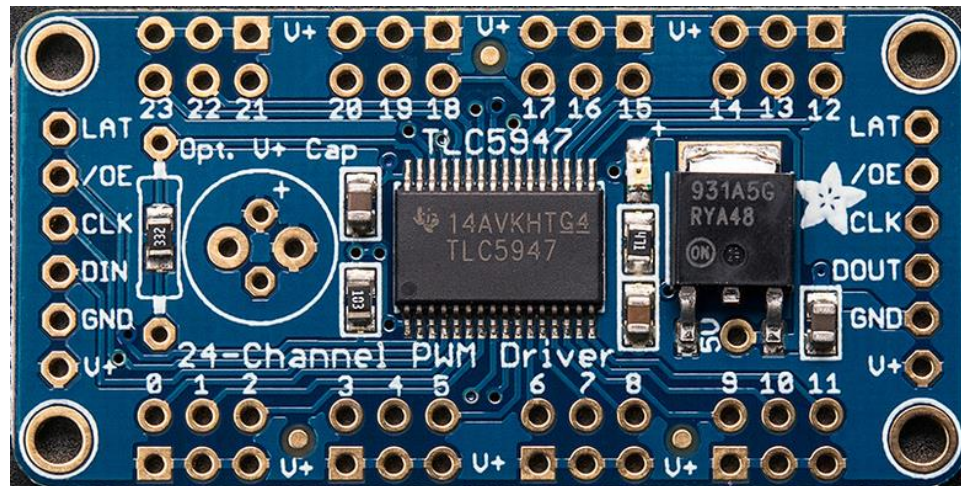

Figure 5.4-1 LED driver

The LED's that were chosen are from SuperBrightLED.com, part number YSL-R547W2C-A13. These are high flux LED's, that produce an average of 10 lumens at 3.2 volts and 20 milliamps. This driver supports up to 24 LED which is perfect for this project. The power will come directly from the battery so there is little draw from the microcontroller. This driver is controlled by using SPI communication so only four pins will be used to control the lights. By placing four of these on each of the 6 splines on the umbrella, 24 LED's were able to be utilized with separate controlling capabilities for each LED. This enabled the group to consider multiple lighting options when programming the entertainment lighting scheme. This added more flexibility to the design.

## 5.5 Motor Design

In order to control the motors it is required to use a driver to act as a gateway between the microcontroller and the motors. The driver chosen by the group is the EasyDriver ROB-12779 by Brian Schmalz. This driver makes controlling the motors much easier than trying to just use the microcontroller. If the group tried to control the driver there would not be enough current to move the motors. The driver takes input from the microcontroller and input from the solar panels. It will also output the power signal to the motors. This model has the added benefit of a sleep function. This function allowed us to shut down the power to the motors and also reduced the amount of power used by the driver. Below in Figure 5.5-1 is a picture of the driver with the pin labels.

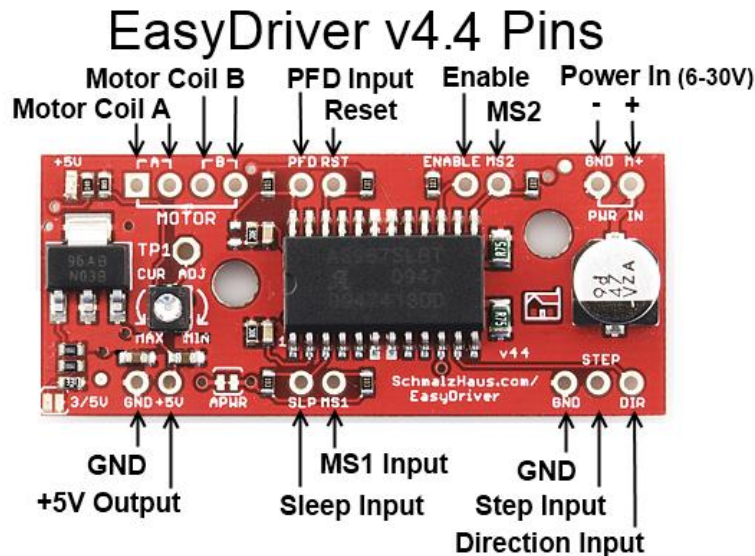

Figure 5.5-1 ROB-12779 EasyDriver Pin layout.  
(Courtesy of Brian Schmalz)

To understand how the driver functions the group must know what each of the pins on the driver represent. Starting from the top left are the motors coil pins A and B. These function as the output to the motor coils in order to make the motor move. There are two for each because current is flowing through a coil to act as an inductor. One is A+ and the other is A-, the same applies for B+ and B-. The next pin is the PFD input; this pin controls the current decay mode for the driver. If this pin is greater than 0.6 times  $V_{cc}$  slow decay is activated. If it is lower than 0.21 times  $V_{cc}$  fast decay is activated. In between these values a decay that is neither fast nor slow. This mode has many features that add to the performance aspects of the motors. The next pin is the RST pin, this pin when sent a digital signal or logic "high", it will allow the motors to be controlled. When it is sent a digital signal "low", it will disable the internal FET and the driver will not respond to any STEP commands sent to it. ENABLE is the next pin that controls whether or not the driver is working. This is a logic input from the microcontroller, when it is set "low" the internal FET will be enabled and the driver will function as it is

designed. When this pin is set to logic "high" the FET is disabled and the driver will not function. The next pin is the MS2 pin, this pin will be explained later when we review the MS1 pin. The last two pins at the top are GND and M+. These are used to input power from whatever source you have. The GND pin must be attached to a ground of the power source. This leaves the M+ pin to be attached to the source positive. These pins have a voltage difference ranging from 6 to 30 volts. Now to the bottom of the driver, the first two pins are GND and 5V. These are here so that other boards can be powered by this board. The GND is internally connected the ground on the top of the board. The 5V supplies 5 volts to an external component. This is limited to the amount of current it is able to supply to no more than 70 milliamps. Next is the SLP pin, this pin controls the sleep mode on the driver. When this pin is sent a logic "low", it turns off the internal circuitry of the driver and shuts down the output to the motors. This mode will enable the group to sleep the motor system when it is not needed. In order to override this mode, a logic "high" must be sent to this pin. The next pin is the MS1 pin, this pin along with the MS2 pin from the top are used to control the type of stepping signal sent to the motor. This driver is able to send four different type of stepping signal to the motor, they are full, half, quarter, and eighth step. These pins are controlled with the microcontroller logic signals. To show how each of the pins will need to be set to in order to affect the step type, review Table 5.5-1. The next pin is another GND pin, which is also connected to the other two GND pins to the ground of the system. The second to last pin on the board is the STEP pin. This pin is used to control when the motor is to take another step. When this pin goes from logic "low" to logic "high", the driver will command the motor to take one step. This is done on the rising clock edge, so when the logic is set back to logic "low" nothing will happen. This is a really powerful tool for the group as the driver will handle turning on and off each of the correct coils in order to make the motor step. The last pin is the DIR pin. This pin controls the direction of motor rotation. By changing the logic input from "low" to "high" or "high" to "low" will change the motors rotation direction. This will only take effect on the rising edge of the next STEP command.

<b>MS1</b>	<b>MS2</b>	<b>Step Type</b>
<b>L</b>	<b>L</b>	Full (2 phase)
<b>H</b>	<b>L</b>	Half
<b>L</b>	<b>H</b>	Quarter
<b>H</b>	<b>H</b>	Eighth

Table 5.5-1 EasyDriver MS1 and MS2 Truth table

On this board there is a couple of jumpers that need to be addressed in order to make sure that the driver is set up and functioning properly. The first jumper that the group will review is the 3/5V jumper. This jumper, pictured in Figure 5.5-2, will set what type of logic input is being used on the board. This board is set up to receive either 3.3 or 5.0 volts from a controlling source. By default this board



is set to accept 5.0 volts, if the jumper is soldered it will operate in 3.3 volt mode. For the use of the project this will need to be set to 5.0 volts which means the group will not have to solder this jumper.



Figure 5.5-2 3.3/5 volt jumper  
(Courtesy of Sparkfun Hook-up Guide)

The next jumper that needs to be reviewed is the APWR jumper. This jumper controls whether to enable the 5V and GND pins located at the bottom of the driver. This is a great feature of this driver as it can power other boards without have to get power from the microcontroller. When you solder this jumper it activates these two pins. This function will not be utilized for the design of this project. Below in Figure 5.5-3 the jumper is pictured.



Figure 5.5-3 APWR jumper  
(Courtesy of Sparkfun Hook-up Guide)

Another component on the driver board that has a need to be reviewed is the current potentiometer. This is located on the middle left side of the board. This item is pictured below in Figure 5.5-4. This driver has the ability to control the amount of current that is feed to the motors by way of this potentiometer. The range of the driver current is from 150 to 750 milliamps.



Figure 5.5-4 Current Potentiometer  
(Courtesy of Sparkfun Hook-up Guide)

This is measured in current per phase. The motors selected by the group for this project need to take a maximum of 280 milliamps per phase. In order to make sure the groups sets the potentiometer to the correct number value, the group will have to run a few test set ups on lower current per phase settings to ensure the motor is not given too much current.

## 5.6 PCB Design

The group was required to create the main PCB that housed the microcontroller. This was done by using Eagle design software. The group actually created two PCB's in this design. Both of these PCB's were sent to Osh Park after the design and they did a great job creating these boards for us. The first PCB that was created has the final design of the MPPT, The li-Ion battery charging IC, and the five volt regulator. It was split into three parts to help in the populating and testing. Figure 5.6-1 shows the Eagle board that was ordered.

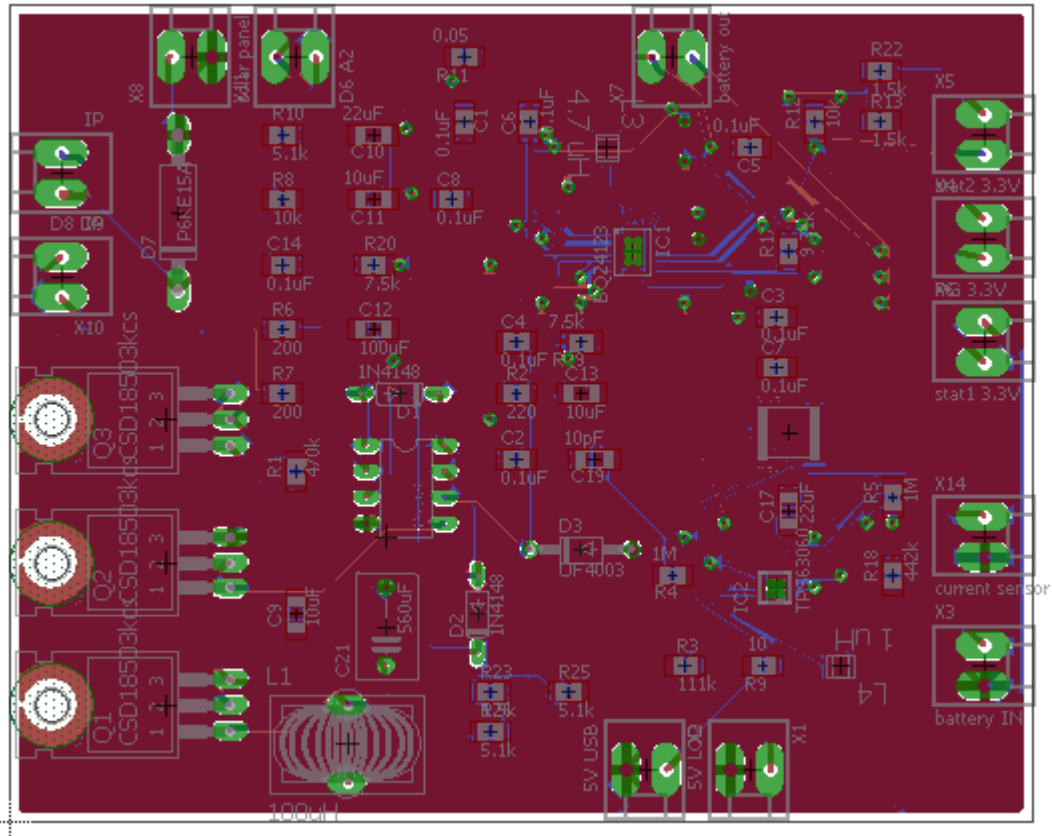

Figure 5.6-1 MPPT, Li-Ion battery charger, and 5 volt regulator

The second board that was created for this project was the ATmega2560 board. This board housed the microcontroller used in this project. Figure 5.6-2 shows the board layout of the second PCB. Two ground planes were used in the design but to show the hand routing that was done on this board they have been left out in the figure below. This design was created using a barebones ATmega2560-16AU design that was located on the internet. This schematic did not have any of the output pins located, so these pins needed to be terminated. This was hand routed by one of the group members.



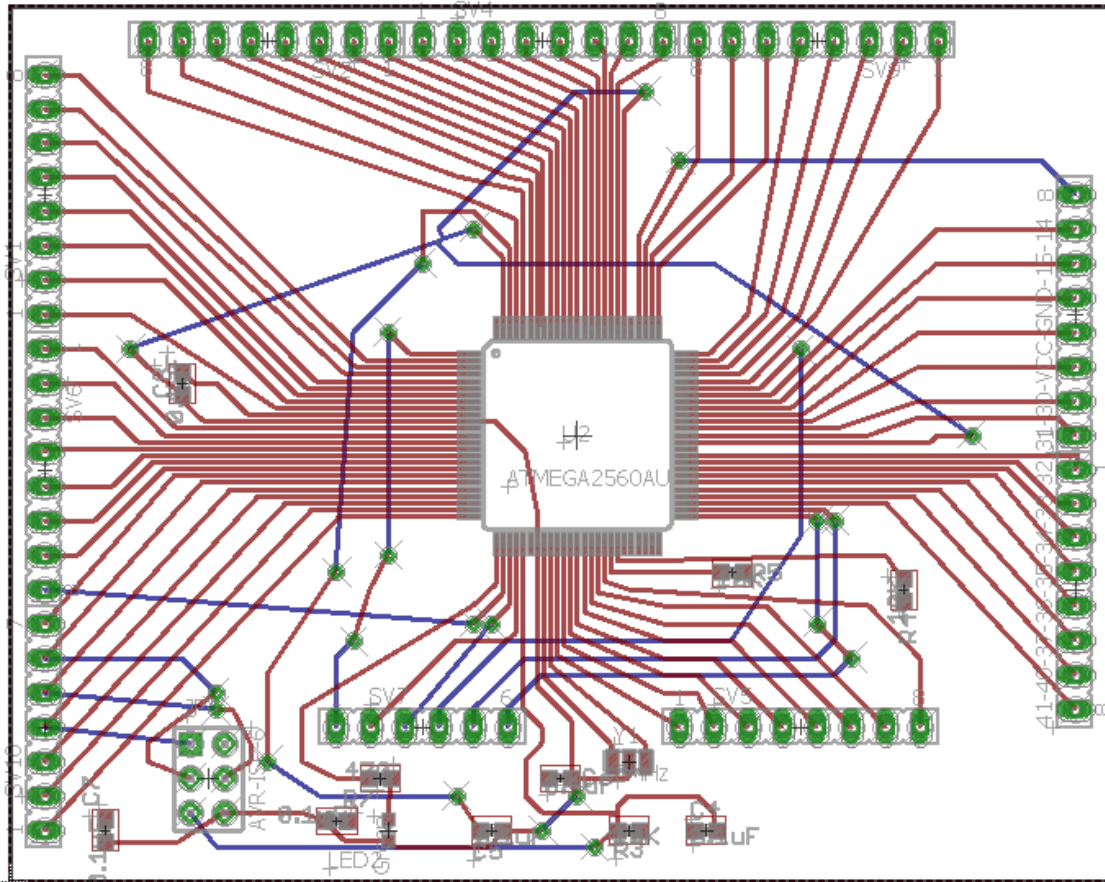

Figure 5.6-2 ATmega-16AU Eagle board

This board ended up giving us a big headache when populating the board and getting it to download the bootloader and code. Figure 5.6-2 shows the board before added VCC and ground were added to input power to the board. Figure 5.6-3 shows a close up of the resonator and shows the issue that we had to fix on this board before we could even read the IC.

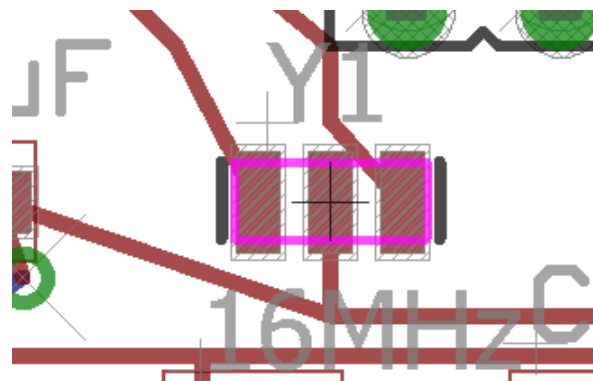

Figure 5.6-3 Resonator input grounded close-up picture

Once this was added into the design then one side of the 16MHz resonator's traces ended up getting grounded on the center pad. Cutting the ground pad in half and removing the upper half actually solved this issue and allowed us to use the PCB in our project.

## 6.0 Project Software

### 6.1 MPP Tracking Algorithm

#### 6.1.1 Overview

After doing much research in previous sections the umbrella will utilize a buck converter and its algorithm to achieve maximum power point tracking. The first thing that the algorithm has to take into account is the switching frequency that is required to switch the MOSFETs to achieve at least 90 pct. efficiency. Having an efficient algorithm is vital to ensuring the MOSFET driver is sufficiently getting the current needed to drive the gate of a MOSFET. The gate capacitance of the MOSFET has to be charged to turn on the gate allowing it to turn on and discharge it to switch off.

The algorithm the microcontroller utilizes is most commonly known as Perturb and Observe (P&O) algorithm or "Hill Climbing" algorithm. This is currently the most common algorithm used in MPPT designs due to the algorithm using simple feedback and little measured parameters. The algorithm is extremely efficient with little error. Even though the algorithm is most commonly used, it still has its drawbacks in which will be discussed later. In the Perturb and Observe algorithm, this approach starts off with the module voltage and is periodically given a perturbation, which is a deviation of a system, moving object, or process from its regular or normal state of path due to weather conditions. After its initial perturbation, the system will give it another. Figure 6.1.1-1 is a diagram of the direction the algorithm will follow to find the maximum power point.

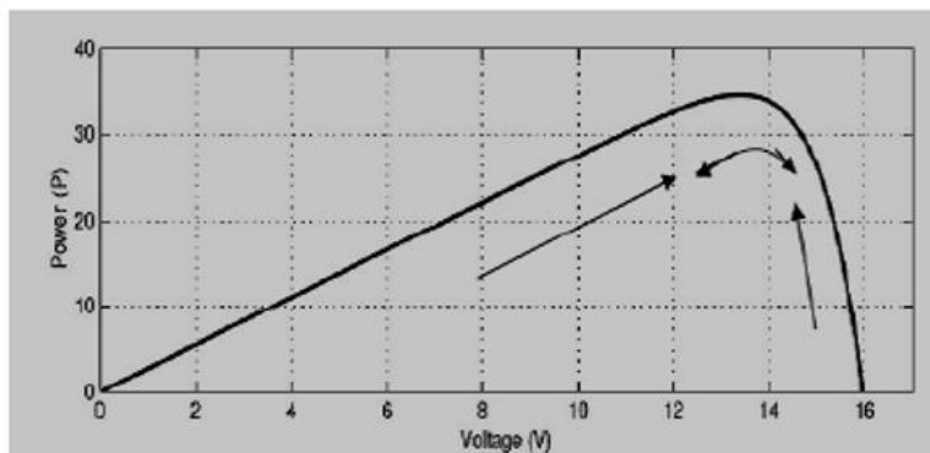

Figure 6.1.1-1 Graph Power versus Voltage (Perturb and Observe Algorithm)  
(Courtesy of Wikipedia)

The second perturbation will compare its corresponding output power to the previous perturbation cycle. If the power is greater in the next perturbation than to the one previously, then the perturbation is continued in the same direction. This will continue until a reading of a lower power occurs in which perturbation is reverse. Once the peak power is reached the power at the MPP is zero. After the peak power has been reached, the algorithm will oscillate around the peak power point. The perturbation size remains very small to maintain the power variation at this point. This technique will then set a reference voltage of the module so it matches the peak voltage of the module. A PI controller will then act to transfer the operating points to match that particular voltage. One of the drawbacks of this algorithm is that it can display a wrong MPPT on fast changing atmospheric conditions. Even with the drawback on not accurately reading the current maximum power point at fast changing weather conditions, this algorithm is still the most common and popular to use.

### 6.1.2 Software Block Diagram

Figure 6.1.2-1 shows the flowchart of the Perturb and Observe algorithm.

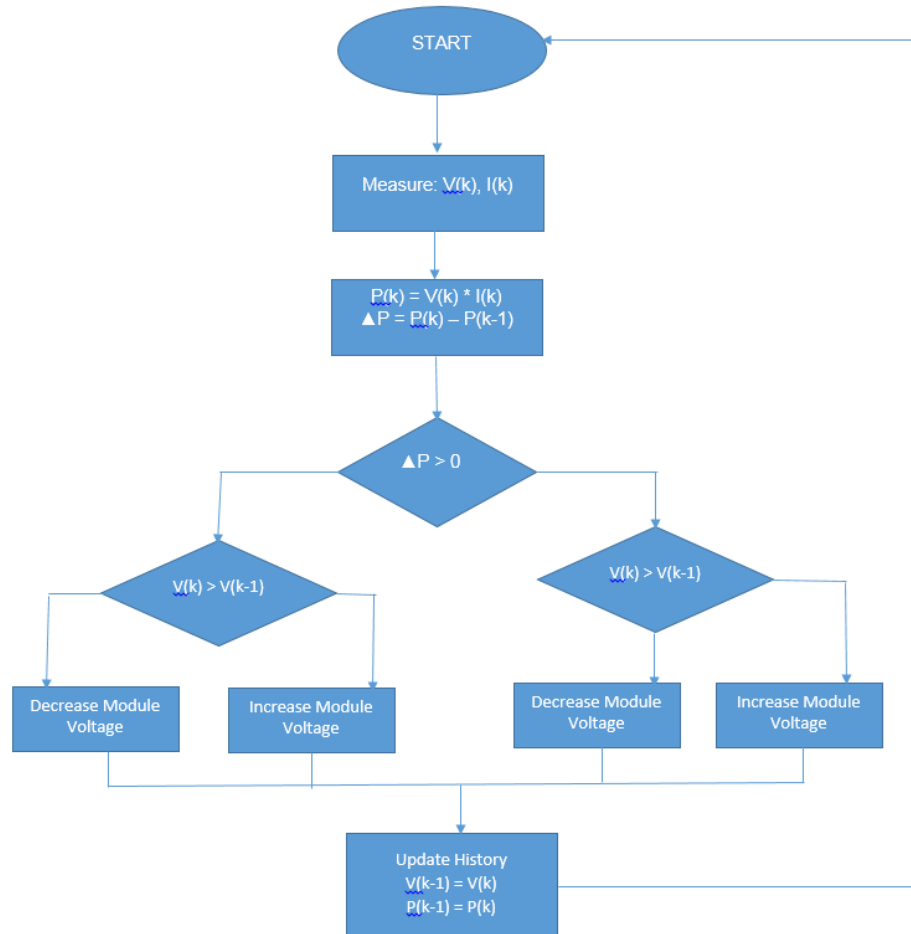

Figure 6.1.2-1 P&O Flowchart

## 6.2 Motor Control

The Smart Umbrella consists of two 7.4 volt bipolar stepper motors. Since the operating voltage of the ATmega 2560 microcontroller is 5 volts, there needed to be a driver or H bridge to control the input voltage of 7.4 volts to the stepper motors. One of the stepper motors rotates the base 360 degrees and the other tilts the top to approximately 30 degrees. The type of stepper motor that was decided for this project is the bipolar stepper motor. Because the current flows throughout the whole coil compared to the unipolar where it only flows through half, the bipolar will end up with more torque. Understanding how the motor works is crucial in understanding how a microcontroller controls it. Figure 6.2-1 is a picture of a bi-polar stepper motor.

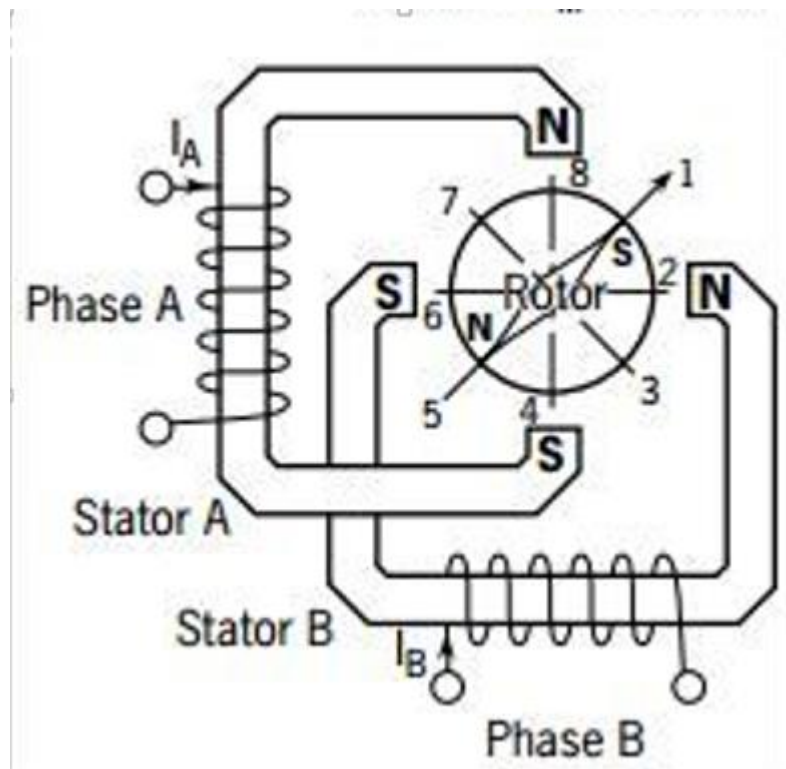

Figure 6.2-1 Bi-polar stepper motor  
(Courtesy of Microcontroller controlling Bi-polar stepper motor)

Knowing the step angle of the particular motor the project is using will help with the calibration of the rotation of motor so it will help the controller determine the correct angular position that it will need to ensure the top of the umbrella and the solar panels are directly aligned with the sun. The bi-polar stepper motor we are using has a 1.8 degree step angle. Since the bipolar stepper motor only has two windings with no center tap and a permanent magnet at the center, the stepping sequence is a little more complex. Each coil has to be powered in such a way that the polarities of the poles are reversed. Table 6.2-1 is a table of this polarity sequence.

Step	A	A\	B	B\
0	+ve	-ve	-ve	-ve
1	-ve	-ve	+ve	-ve
2	-ve	+ve	-ve	-ve
3	-ve	-ve	-ve	+ve

Table 6.2-1 Polarity Sequence Table

The above polarity can be changed to logic levels so the microcontroller can activate one coil at a time. Table 6.2-2 shows the step sequence converted to logic levels.

Step	A	A\	B	B\
0	1	0	0	0
1	0	0	1	0
2	0	1	0	0
3	0	0	0	1

Table 6.2-2 Step Sequence Table

Using the logic levels in Table 6.2-2, the microprocessor can activate each coil to allow the motor to operate correctly according to the design requirements. Knowing that we need a H-bridge driver to control the 7.4 volt input from the batteries, we dedicated 4 digital pins for each motor. The ATmega 2560 more than accommodates this with 54 digital I/O pins. To run both motors, only 8 of the 54 will be utilized. Figure 6.2-2 is a diagram of the microcontroller connected to the driver that is feeding the bi-polar stepper motor.

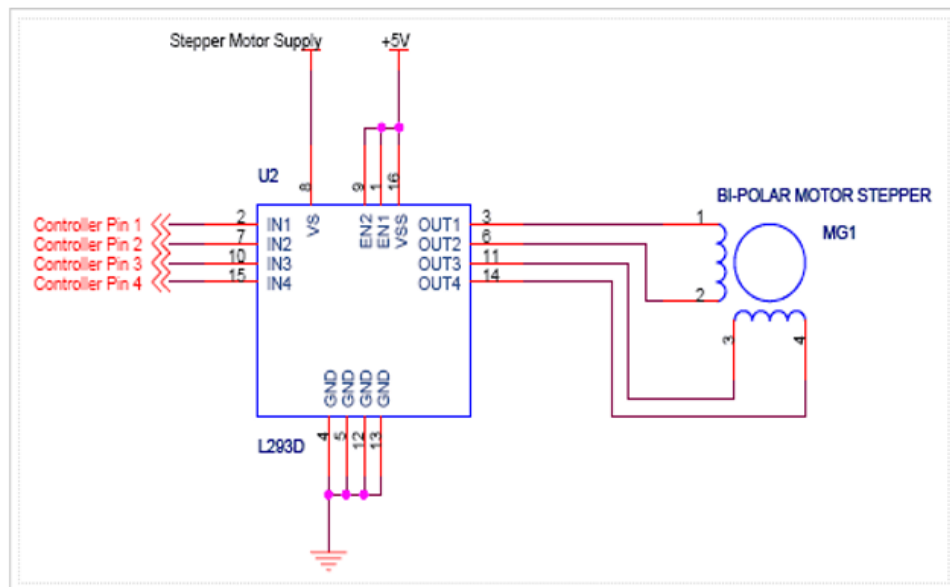

Figure 6.2-2 Schematic of Driver to motor  
(Courtesy of Microcontroller controlling Bi-polar stepper motor)

The programming aspect of this design is what was somewhat tricky. Taking into account the readings of the sun spotter sensor, the microcontroller will then have to communicate to both motors on how to rotate, so the top panel can be aligned with the sun. Once the data is collected from the sun sensor, it has to have pre-programmed positions stored in memory, so it can call that data depending on what reading it gets from the sensor. The initial plan was to have the 360 degree motor be split into 8 positions having it cover 45 degree increments up to 360. This was changed to 4 positions to simplify the coding once it was realized that less accuracy was needed. The top motor that goes from 0 to approximately 30 was found by changing the amount of turns on the shaft and the presetting this value. Having these preset positions and being able to call them once the readings from the sun tracking sensors are retrieved will simplify the design and programming. Using the microcontroller, it can be programmed using C, assembly, or both. These positions are done by ensuring the right cables are turned on. In the evening, when sun light is not present or on an overcast day where the sensor cannot track the sun, the top motor will turn to 0 degrees, in its upright positions and both motors will be turned off, meaning there will not be any current in any of the coils.

At night, whether it is on your patio or on the beach, the design incorporated a special mode or "party" mode. In this mode along with have different lighting patterns the umbrella also has the option to spin. This was controlled by the bottom 360 degree rotational motor. This motor will be controlled on a half-step sequence to ensure stability and fluency. In half step sequence, the motor step angle is reduced to half of the full sequence mode. In half mode sequence it requires doubled the number of steps of full mode and the Table 6.2-3 below shows the required steps to rotate 360 degrees.

Step	A	B	A\<	B\<
0	1	1	0	0
1	0	1	0	0
2	0	1	1	0
3	0	0	1	0
4	0	0	1	1
5	0	0	0	1
6	1	0	0	1
7	1	0	0	0

Table 6.2-3 Half Mode Sequence

Energizing these specific coils using the bits above will magnetically rotate the center. Having this option along with the lights will improve on the flash aspect of the design and will add to the entertainment factor.

## 6.3 Lighting Control

The Smart Umbrella also feature a few lighting modes. At night when the sunlight is not present the Smart Umbrella has four LED's running down the each of the 6 splines of the umbrella. The umbrella features a number of modes where the light will either stay on for reading/seeing purposes and multiple modes, or "party modes" where the lights will blink a certain pattern. Placement of the light emitting diodes will be vital to ensuring each light is supplied with enough current. As discussed in the previous specifications, a driver will provided the correct current for each LED. Since the 5mm cool white high flux light emitting diode only requires a maximum of 20 milliamps and 3.2 volts, the group can connect the LEDs directly to the driver which will provide the current about 15 milliamps constant independent of the input voltage. In order for the group to control the LEDs, Serial Peripheral Interface will be used. For this application there are 3 pins that will be connected to the driver which are the data, clock, and latch pins. With the Adafruit library, any digital pin can be used to control the LEDs. This makes coding the project much easier, all that is needed to call function and store the values to the appropriate channel and position. Then call the write function and the corresponding LED will light up. Figure 6.3-1 is a diagram showing the how the flow works for SPI communication.

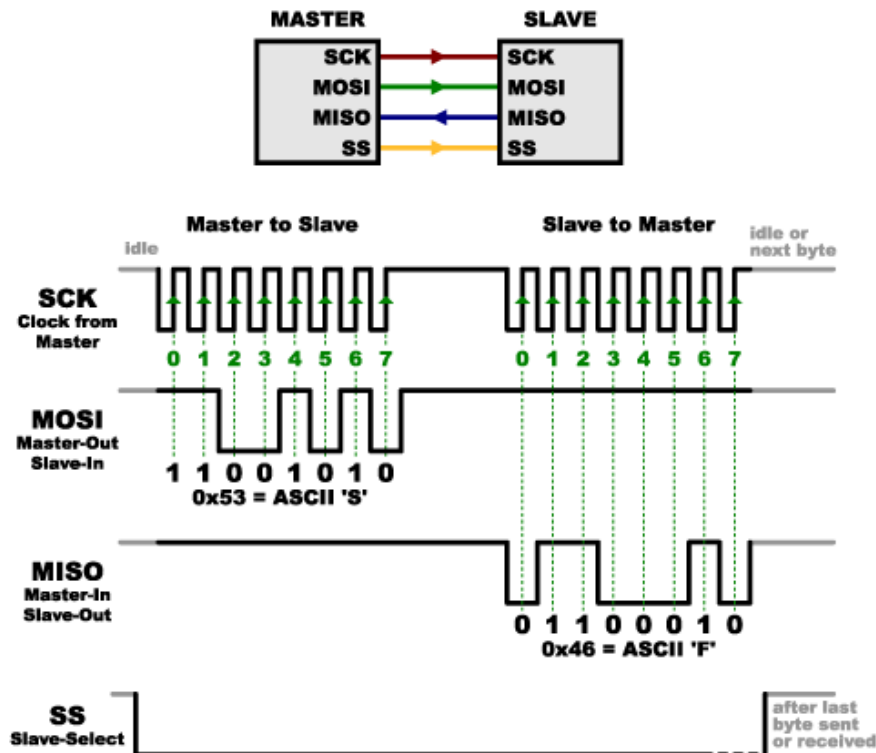

Figure 6.3-1 SPI  
(Courtesy of Adafruit)



By using the LED driver we have reduced the number of pin from 24 to 4. Another benefit of using this driver is that it has a sleep function built into the driver. When the sleep pin is pulled high the driver will shut off the LED and reduce the power consumption of the driver to minimal levels. This adds to the efficiency of the project. Because this driver features pulse width modulation, it allows the group to actually control the intensity of the the LEDs. That means that the group can actually make the LEDS fade in and out with simple call functions within the main programs code. Figure 6.3-2 is a picture of the LED driver connected to 12 LED and making them bling in sequence. With very little lines of code the group was able to make the LED blink in very different patterns which is exactly what the group needed for the next mode that the lighting system need to be able to do.

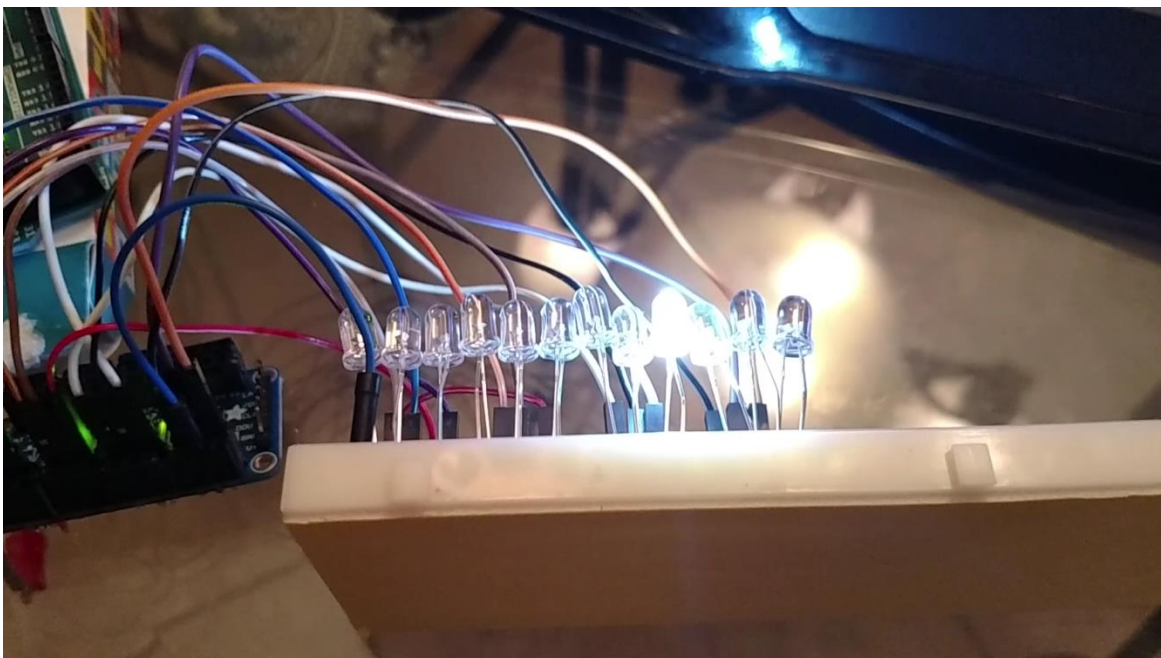

Figure 6.3-2 LED driver connected

There is a variety of lighting modes the Smart Umbrella features. Each mode will have its own switch setting, as well as an off and on switch to the entire lighting system in the cases where the user doesn't want the lights to be turned on. Adding a switch will simplify the design in the case where it doesn't have to keep track of where the sun is during the day. The umbrella is simply giving the user the option to run the lights, even if it's in day light. The first mode will be a standard lighting mode where the umbrella will turn on all 24 light emitting diodes to supply constant lighting for the user, whether it be an evening at the beach or a night on the patio. The standard mode switch will simply assign high bits to all pins connecting to the LEDs with no delays, so all 24 LEDs are constantly being supplied current and voltage until the switch is in the off position.



The next mode will incorporate a fun or "party" mode where the umbrella will add a little flash. The umbrella will have various settings of lighting patterns. One of the lighting patterns will be a circular pattern where two splines of LEDs will flash one at a time moving onto the next spline in a clockwise rotation, making a helicopter display of lights. This will involve setting the right delays in between each set of LEDs, all in a while loop. Keeping track of which set of LED's is attached to which pin will be detrimental in accomplishing this. Turning the high bit on the pins of the next spline to maintain order of the rotation will have to be carefully looked at and tested. This mode will be turned off and on from the switch that will be installed. Figure 6.3-3 is a diagram of the order the set of lights will flash at a 1 second interval. This will happen continuously until the user turns the mode off.

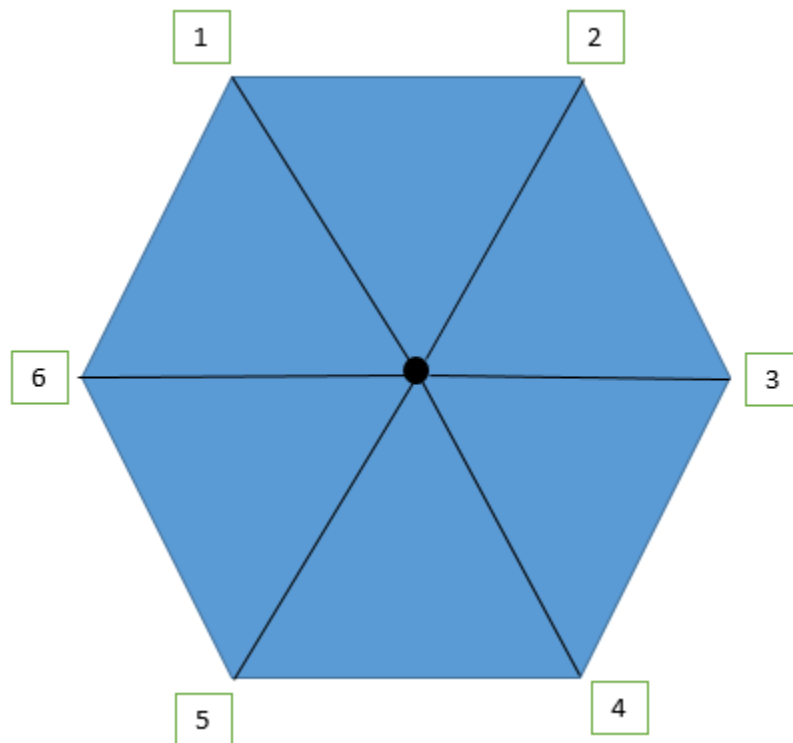

Figure 6.3-3 Mode 2 Lighting

The next mode will light up 3 splines of LEDs at a time, alternating an off spline in between each one that's on. This will also flash at 1 second intervals. The programming in this will be to group the 6 different sets of LED's into two groups and alternating the bit pattern on each group. Splines 1, 3, and 5 will be group 1 and splines 2, 4, 6 will be in group 2. Setting group 1's pins to high while group 2 is low and then switching it every second will allow the LED's to flash in this pattern. Adding delays in between group to ensure they are alternating correctly. Figure 6.3-4 is a diagram of group 1 and 2 of the LED's.

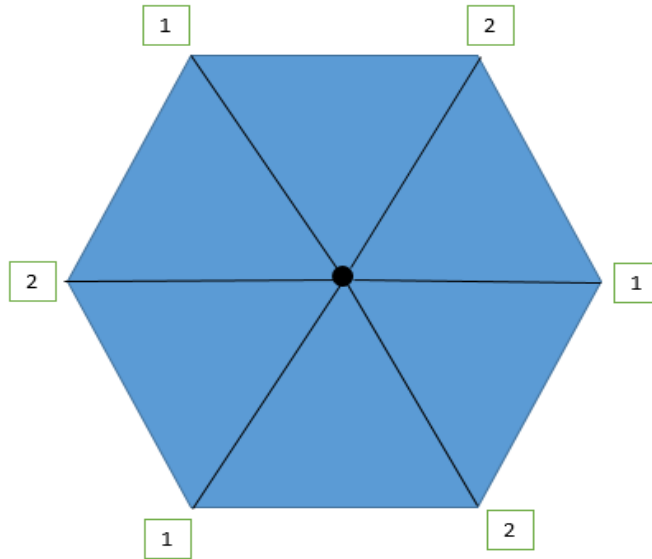

Figure 6.3-4 Mode 3 Lighting

The last mode will consist of splitting the umbrella in half. Each half of the umbrella will light up and alternate with the other half. Figure 6.3-5 is a diagram of mode 4. Groups 1 and 2 are alternating and group 3 is constantly on.

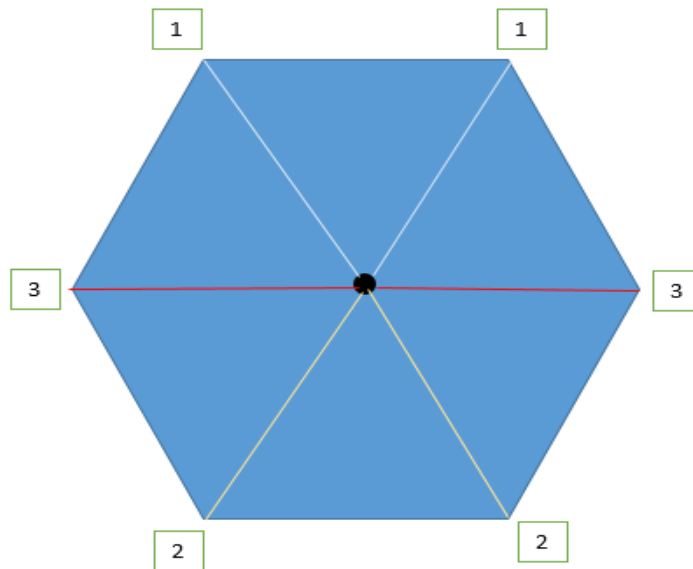

Figure 6.3-5 Mode 4 Lighting

This is pairing up the splines into two different groups like in Mode 3 but with splines 3 and 6 constantly putting out a high bit to ensure those sets of LEDs stay on. Instead spline 1 and 2 will alternate with 4 and 5 at one second intervals.

The programming will be different by having two while loops in this module with the first loop containing splines 3 and 6 with no delays and a constant high bit. The second will contain the two groups alternating with delays and alternating high and low bit assignments. Adding these different methods of lighting control, adds a little flare to the design and can be natural attractor to the design itself. Having correct algorithms to support these modes was vital in having a complete and finished product.

## **7.0 Project Construction**

### **7.1 Pole Design**

To imagine the overall pole design of this project it was decided to construct a three dimensional model of the design. This model was constructed by using a program called FreeCAD. It is a free computer-aided drafting program. This program allowed the group to construct models of what the final product will look like. The pole was manufactured out of steel and measures the total length of 7.3 feet. It is of round design and has a diameter of 1.25 inches. Because the material is made of steel it will resist oxidation, and other factors that diminish the life of a product. It also has the benefit of being light weight and strong. Steel is a widely used metal so getting this material for manufacturing is easy to do. Another reason that steel was chosen for this project is that it is easy to weld things to the pole. This will create a strong bond between the pole and objects being welded. Because motors are used in this project, the way that they were attached to the pole was crucial. It was also easier to drill holes in the pole for mounting of other components that were used in the project. The umbrella pole is able to be used in a patio table by just sticking the pole into the patio table. The umbrella tilts to make sure it can face the sun when it is not directly overhead of the unit. This was done by attaching a hinge to the pole just below where the umbrella support structure slides down the pole. This was done to ensure the unit will still fold down to make sure it is still mobile. This hinge was also needed to take a large amount of the weight off of the motor shaft. This was because most of the weight of the umbrella is located at the top. To ensure that this is done properly, the group drilled holes to attach the hinge to the pole. Then the group JB welded and bolted the hinge into place. This gave the hinge extra strength. Additional supports were also used because of the play in the hinges used in the design. These supports were bolted close to the pole at the hinge so that the pole stayed straight and could only swivel in one direction. Figure 7.1-1 shows a picture of the final Smart Umbrella and also shows how close to our original design picture the group actually came.



Figure 7.1-1 Umbrella Design

## 7.2 Motor 1 Structure Design

This design has two motors used to control motion of the unit. In this section, the design of the first motor will be discussed. This motor is responsible for rotation of the whole upper portion of the umbrella. This is going to be used for two different function of the project. The first function is during dancing mode, the umbrella spins in a circle with the lighting system blinking on and off. The second function of the rotation is to keep the umbrella facing the sun. This is the main function of the project. After reviewing many different types of ways to mount the motor it was decided that putting the motor in the shaft of the pole was the best idea. A special housing box was needed to fit the motor itself. This has

many benefits that make it the best choice for this project. Because the motor is mounted in the shaft of the pole it is hidden from the user. This does make it harder if repair is required of the motor, but the average user will not be taking this type of product apart. Another benefit is that the motor is isolated from the environment. This means it will help keep the motor from getting sand and water inside the motor. With the motor inside the pole, all of the wiring for the motors is concealed inside the pole itself, making the overall look of the pole more streamline. In order to envision how this design looks the group created a three dimensional model of what the final product looks like. This is pictured below in Figure 7.2-1. This is a cross-section of the pole; the solid part on the right of the picture is the upper part of the pole. The transparent part is the lower part of the pole. The motor was mounted in the upper part of the pole with the shaft of the motor facing downward. This effect allows the wires for the motor to be ran up the pole

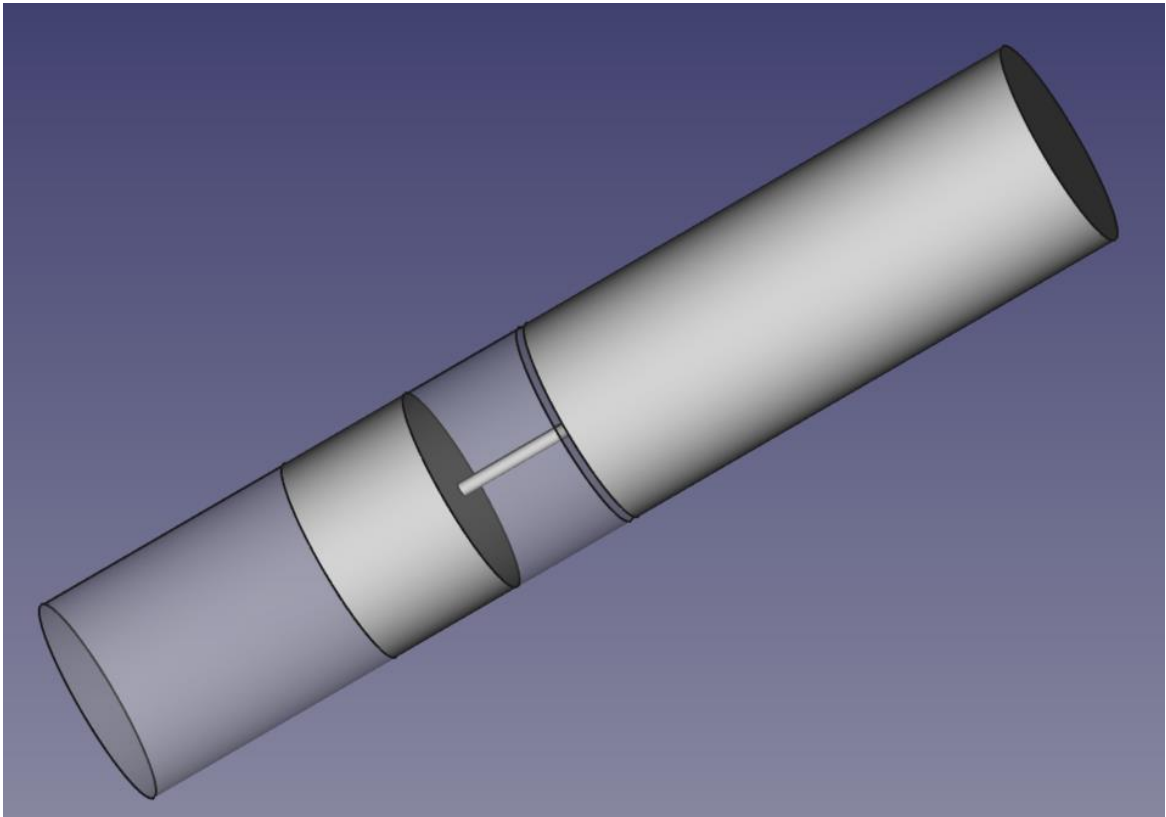

Figure 7.2-1 Rotation motor model

Because the group decided to do this, it keeps the wires from tangling and twisting as the top of the umbrella spins. In order for this to work, the base of the umbrella needed to be fixed as the motor will rotate the top of the unit. On the shaft of the motor the group attached a 10-24 all-thread extension using a 5mm coupler; this was fixed to the lower portion of the pole. In order to reduce the amount of pressure on the motor, the group decided to add a ball bearing in-

between the upper and lower parts of the pole. This makes the top roll on the ball bearings and reduces the overall friction of the motion. The group believes that this was the best design of the bottom motor.

### **7.3 Motor 2 Structure Design**

The second motor that this project utilizes is responsible for the tilting of the upper portion of the umbrella. This motor design is important because it is part of the main function of this project. The group drafted many different types of designs for this motors. The initial goal was to hide the motor in the pole just like the bottom motor. This would utilize a ninety degree gear or pulley system to in order to pull and release the upper portion of the umbrella. A piece of cord would attach to the top of the umbrella and would be wound around a pulley when the umbrella was in the vertical position. By the added use of pulleys it would help reduce the overall weight of the motor would have to pull. After much thought it was decided that this was not going to be a good way to design the motor as there is limited space to work with inside the pole and the motor might damage the wiring that is going to be running down the pole for the solar panels, lighting, and sensor systems. Trying to fit pulleys and gears in a space so small seemed to be something that would prove too difficult for this project. The next idea was to mount the motor on the outside of the pole. After going through many different configurations, it was decided by the group to mount the motor horizontally. This is pictured below in Figure 7.3-1.

The group noticed during the research phase that the stepper motors have more torque when they push and pull. In order for this design to become a reality the group must mount a hinge on the left side of figure below. This hinge will act a way to reduce the overall weight on the motor as well as have a fixed point the umbrella will drop. This was described in detail above in section 7.1. Now that the pole had a place to tilt, it required the creation of something that the motor would mount to in order to function. The idea that the group came up with was to weld a piece of metal to the top the fixed pole just before the tilting portion of the umbrella. This acted as a place to mount the motor to ensure that it would stay in place. This is pictured below on the right side of Figure 7.3-1. The motor is then mounted to this piece of metal. This is depicted below as the cylinder object on the right side of the figure. This was held in place by four bolts using the existing holes in the motors. This required drilling holes in the piece of metal in order to make a place to mount the motor. Now that the motor is mounted in the horizontal position, it must be able to move the upper portion of the umbrella. In order to do this, the group decided that using a threaded rod attached to the shaft of the stepper motor. Inside the upper portion of the pole, the group mounted a 10-24 coupling to a cotter pin for the threaded rod to screw into. After much discussion, it was realized that the coupling cannot be fixed as the pole dropped the bolt would need to be able to stay in the vertical position. This proved to be a difficult problem for the overall design the group had in mind. Many different



ideas were suggested by the group members, but many of them came with different problems. It was theorized that the motor should be mounted vertically on the side of the unit, and then have the pulley system similar to what was described before in this section. This idea was scrapped as the group didn't want all the excess objects, like the pulley, hanging on the side of the umbrella. In order to combat this problem, the group decided to mount the coupler to a rotatable pin and attach that to the inside of the pole. This would allow the bolt to stay in the vertical position and it would still be able to control the tilting of the umbrella. This design became a very difficult part of this project as the members of this group have limited background in the mechanical engineering aspect.



Figure 7.3-1 Original tilt motor model and final build of tilting motor

## 7.4 Solar Panel Location and Design

In this section the group will outline the design of the solar panels. This is the primary source of energy for this project. It is crucial that the panels are going to be able to face the sun to collect the correct amount of light to keep the system operational. The movement is done by way of motors, but the motors will need

energy in order to operate. This is where the solar panels come into to play. In order to produce enough power for this system to work, the group used twenty eight photovoltaic cells. These cells were connected in series. The umbrella top is made of six sections separated by six splines. These sections fold in half when the umbrella is closed. This makes mounting the solar panels complicated. In order to make sure the panels do not fold in half, they had to be placed in a way that would conform to the umbrella. Figure 7.4-1 shows a top down model view of the umbrella that was initially designed.

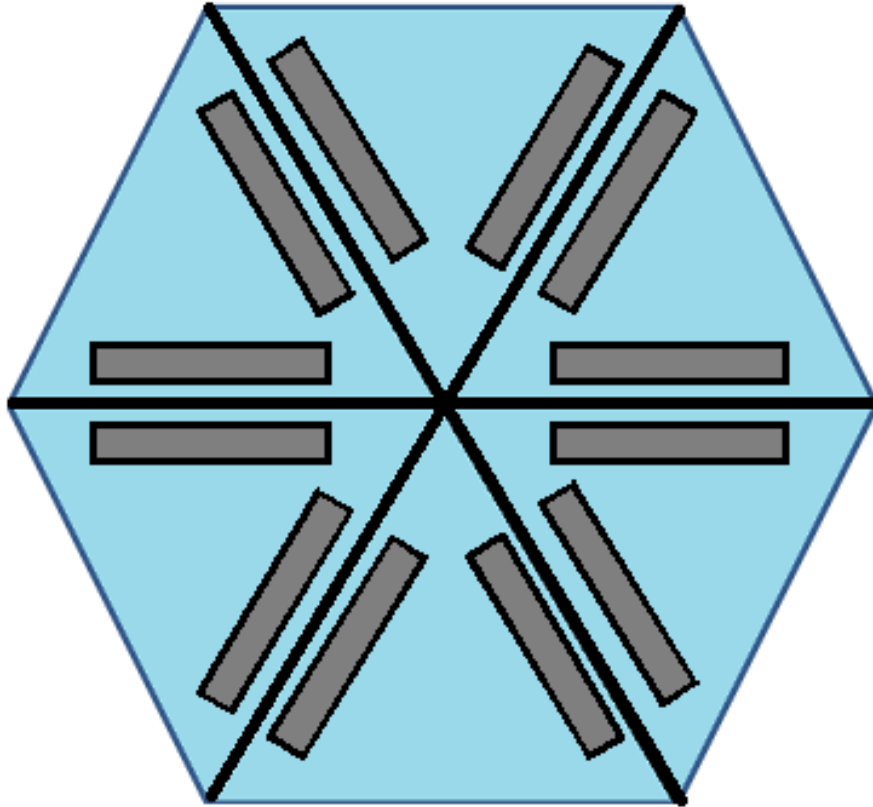

Figure 7.4-1 Initial top down model view of solar panel placement

The black lines are the spines of the umbrella. The gray blocks are the solar panels. When the panels are set up in this pattern, the umbrella folds up without any of the panels getting folded or creased. Each gray block represents two photovoltaic cells, this give the project the overall twenty eight that is needed to achieve the required power output. With two of the panels together the overall measurement of each block is three inches by fourteen inches. With the radius of the umbrella at just over forty four inches there was plenty of space to put the panels. In the final design two extra panels were mounted at two spots on the umbrella. This was done to increase the panel size to make sure that the MPPT had sufficient voltage to supply the battery. Figure 7.4-2 shows how the solar panels were mounted in the final design.





Figure 7.4-2 Final solar panel layout

It is easy to see that the final product closely mirrored the model that was initially drawn in our design stage. By placing the solar cells near the splines the group was able to still fold the umbrella for storage or transporting purposes. The wiring of each panel was then secured along the splines of the umbrella. This gave a guide for the wiring and also protects the wires from getting damaged. The group felt that this was the best way to make sure all aspects of the design were met.

## 7.5 Circuitry and Battery Location Design

In order to make this unit function, there needed to be a place to put all the components that the project contains somewhere. The group thought of many different ways to contain the equipment thought the course of the project development. The first rendition of this design had the pole containing all the components. This design was very streamline, but trying to fit all the parts that were required into a pole measuring 1.25 inches in diameter proved to be a great challenge. In order to come up with a new design idea the group started thinking of other ways to contain the parts. The idea that there should be a box or

container attached to the pole. This container houses the battery, the charging circuit, the microcontroller, and all other necessary parts needed to make this unit function the way it was theorized. This container is pictured below in Figure 7.5-1. The container has a liquid crystal display, pictured in light green in Figure 7.5-1, on the outside of it to display useful information about the efficiency of the battery.

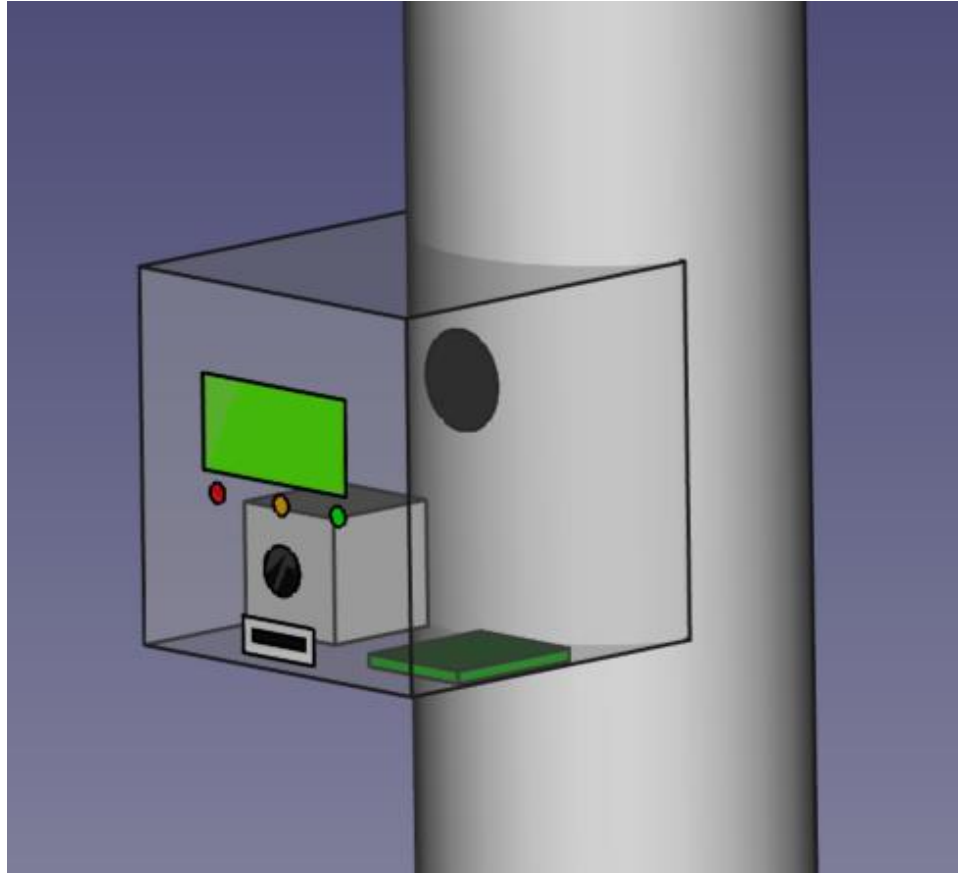

Table 7.5-1 Container with display

There are also three light emitting diodes, pictured in red, yellow, and green in Figure 7.5-1. These were used to display the state of the battery charging. The same container also houses the universal serial bus port for charging up a mobile device for the user. The port is pictured in Figure 7.5-1 as the white rectangle with black rectangle inside of it. This container was mounted directly to the pole. The area that this was mounted was near a normal table height. This means that the user will be able to see display and use the charging port. This container has gone through many different versions. The first idea was to have the container be a circular shape going around the pole in a toroid type shape. This idea was changed when the group decided to have a display. The container was changed to a square shape as it was easier to mount to the pole. This way it is also much easier to put a display and charging ports in the container. As stated earlier it was placed just above the table top. This is just above the spot where the

rotation motor is placed. A hole was also drilled into the pole behind the box in order to run all the wires to the rest of the system for this project. The hole is pictured in Figure 7.5-1 as the black circle inside the box on the pole itself. This hole has wires coming in from the solar panels to the charging circuit. This hole also has the wires running to the motors, and the lighting systems. With this setup the group was able to better weatherproof the design as most of the components were sealed in the box with the wires running up the pole. Figure 7.5.2 shows the final product with the LCD screen on with the stats being displayed along with the status LEDs and the clear enclosure.

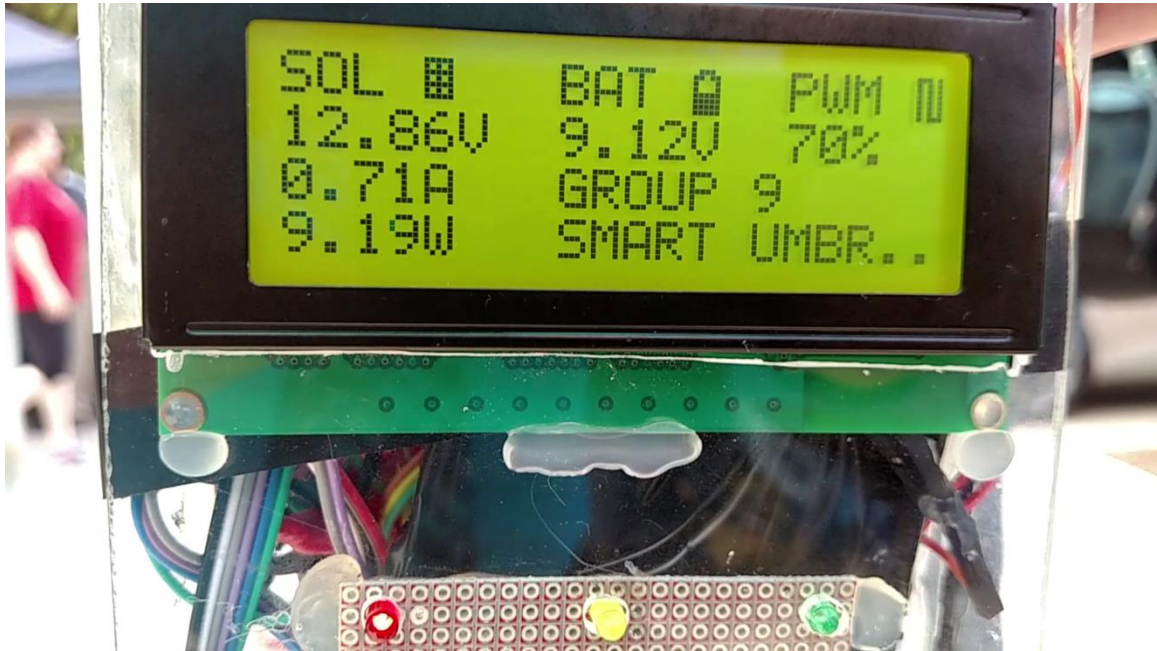

Table 7.5-2 LCD display with status LEDs

## 7.6 LED Lighting Location and Design

The last part of the section will cover the lighting system design. The lighting system will be used during the night to give the user of the umbrella lighting. This was also utilized during the dancing mode. The only place that makes sense for the light to be located is under the umbrella. The group first reviewed placing the light emitting diodes was the outside border of the umbrella. After the group thought about this plan more it was decided that it would not be a good idea. The light emitting diodes are evenly mounted in groups of four on each spline. This configuration is show below in Figure 7.6-1. Each of the white circles are one of the LEDs. The will placed on the splines in such a way that they will not interfere with the closing mechanism of the umbrella. This is because part of the specifications is that the umbrella has to be able to fold up and be transportable. This ensures that both the lighting and the transportability specifications are met.

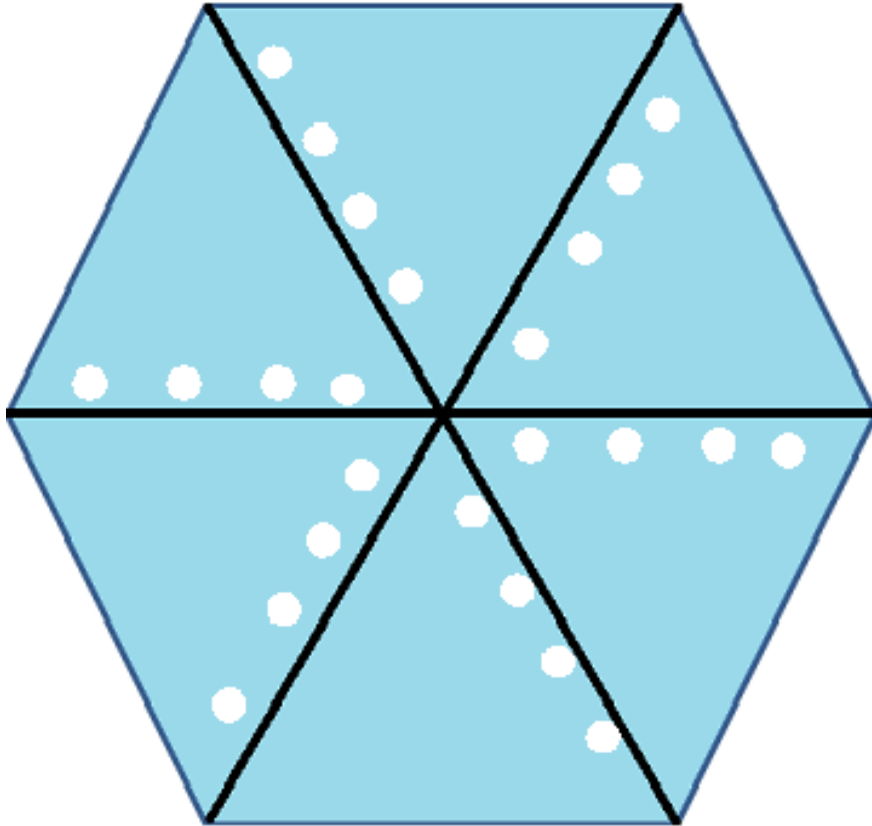

Table 7.6-1 Top down view of lighting placement

This was done because the umbrella will be folded over and over again as the umbrella is closed and opened. This is also where the wires for the solar panel are going to be run so it keeps all the wires in the same place. When the umbrella is closed and opened the splines will not bend and because of this it adds to the rigidity of the wires and lights. The lights are controlled by the microcontroller and are able to be controlled individually. The lights emitting diodes that were selected for this project will be able to be wired by direct solder to the leads on the lights. The wires will run the length of the spline back to the LED driver. Since the LED's and driver are going to be exposed to the elements, the group decided to mount them just under the umbrella top. This will offer the weatherproofing that the project specifications require. The lights themselves were mounted directly to the spline using a glue gun. With the lights configured in this way, the umbrella is able to provide ample light to the user. Another added benefit of this setup is that there are many ways the lights can be lit up in order to create different effects.

## **8.0 Prototype Testing**

### **8.1 Overview**

Along with the design and fabricating the project, one of the most important parts of the design was the testing aspect of the design. This section looks over the hardware and software testing. Testing was key to ensure the functionality and overall quality of the Smart Umbrella and making sure each subsystem was operating at its maximum efficiency. Testing also ensured proper use and making sure all goals and specifications were met throughout the design. The main topics that will be discussed are testing environments, MPPT testing to ensure 90 pct efficiency, subsystems unit testing to ensure each aspect of the design is working properly, integration testing which will combine all subsystems to ensure all of the interfaces are all functioning together as a unit. Lastly there will be a list of testing equipment that the design will require for testing purposes.

### **8.2 Testing Environment**

There are two testing environments that the Smart Umbrella took into consideration, indoors and outdoors. Testing was mostly done in the Senior Design Lab initially. Most of the electronics side could be tested there due to the parts and tools the lab supplied. Along with utilizing the senior design lab, every group member was also responsible for testing their sections of the design. Outdoor testing also needed to be done for the solar tracking and solar panels. Testing the MPPT outside, on different weather conditions also needed to be done to ensure the algorithm was tracking the maximum power point. By using a portable multi-meter we were able to test the MOSFETS to make sure they were switching correctly. Both indoor and outdoor testing was equally vital in ensuring that the final prototype of the Smart Umbrella was fully functional and operational.

### **8.3 MPPT Testing**

The MPPT consists of many parts that needed to be tested to maximize its efficiency. The first part was testing the gate driver and MOSFETs switching of the Buck Converter. To reduce the amount of errors, parts and cost, all testing was initially done on a bread board. This was vital to reduce the amount of blown MOSFETs. First thing to check once everything was connected was the resistance between the input rails. This was important because it should read several KOhm. Once this was checked, an oscilloscope was connected between the voltage source and ground. The result was a PWM with frequency 60.5KHz. Test code will be used to ensure it's operable. Figure 8.3-1 shows the output of our initial MPPT test.

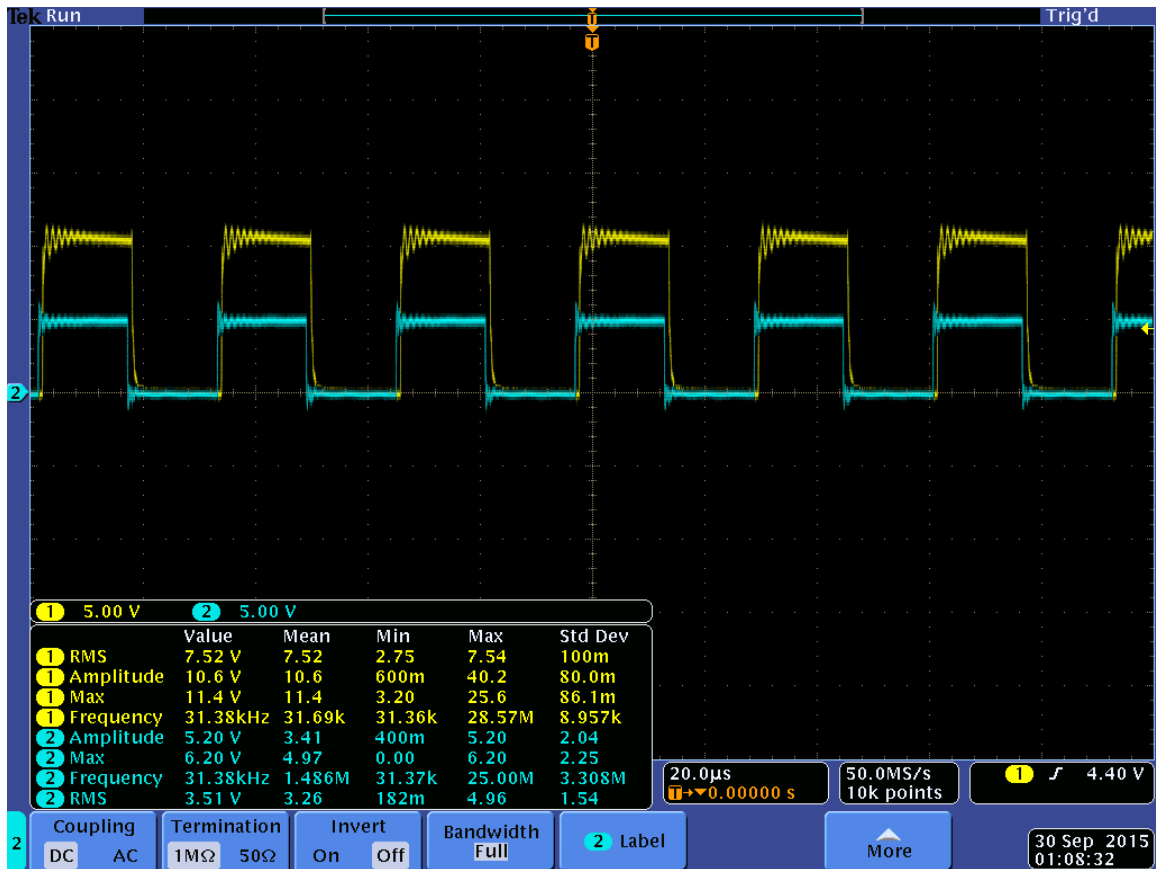

Figure 8.3-1 Initial MPPT test Oscilloscope Reading

The light blue signal is the microcontroller input at a 50 percent duty cycle. The yellow signal then shows the MOSFET’s output signal before filtering. This figure shows the MOSFETS are switching properly. It also shows the slight delay between the input and the output signals. Once these connections checked out, you will then move on to adding the inductor and capacitor that was calculated in the design section to the buck converter. Once the inductor and capacitor are connected, the resistance in between the input rail should again be tested to insure that it is above 1K ohm. Now give power to the input rail and the microcontroller and connect the probe of the oscilloscope in between the output capacitor. Output should be a steady direct current.

Using the formula  $V_{out} = \text{Duty Cycle} \times V_{in}$ , we can verify these results. An example would be calculating a 50 pct. Duty cycle of a 13 volt solar panel; the result will be 6.5 volts. Then connecting the scope in between the gate of the first MOSFET and the ground and testing that you results are a pretty clean DC signal. Figure 8.3-2 shows the initial testing result of the MPPT with the filter added.





Figure 8.3-2 MPPT with filter oscilloscope reading

Next thing that needs to be tested is the input voltage to the analog inputs. The analog inputs can be used to measure the DC voltage between 0 and 5 V. This range can be accomplished by using voltage dividers with 2 resistors. This is useful to measure the input voltage from the solar panel and the input voltage from the battery. Test code was then used to test these results and display on the computer by using the function `analogRead()` which converts the voltage into a number between 0 and 1023. To measure the current, the design calls for a Hall Effect current sensor which will read the current value and convert it into a relevant voltage value. The Smart Umbrella also has the LCD screen to output the voltage, current and power from the solar panels, battery and also give the percentage of the PWM. This was the hardest test out of them all to ensure the umbrella was working at maximum efficiency.

## 8.4 Subsystems Unit Testing

Breaking the testing down to parts helped keep track of the development of the umbrella. These tests consisted of testing the output voltage and current of the solar cells, the solar tracking system, lighting modes, etc.

The most important part with unit testing is testing the input and output voltages. A missed calculation or bad connection can be the cause of wasted material and

essentially more cost in designing. When testing these parts it is important to review each part's specifications to make sure the input voltage and current are within range. The group used the testing equipment in the lab or at home to complete these tasks. Testing the solar cells was one of the most important parts the design had to take into consideration. Without them working properly, the rest of the design was powerless. Each solar cell can produce 0.5 volts. Placing 28 of these cells in series, 14 volts was attainable with an operating current of 2 amps. Placing these correctly on top of the umbrella and measuring this output needed to be done early in the building process. The voltage at the battery was also needed to make sure it was getting enough voltage to charge the battery from the cells. The microcontroller input and output voltages also needed to be measured. The input voltage can be anywhere from 7.4 volts being supplied by the battery to 8.4 volts being supplied by the solar cells and the output voltage will be 5 volts. This was done by using an amp clamp type digital multi-meter. The synchronous buck converter also needed to be tested to ensure the voltage was regulated to 8.4 volts that will be needed to charge the battery and run the load. The 5 volt buck converter needed to be tested to ensure proper output. All of the output pins of the microcontroller have a 5 volt output, these were tested individually to verify that 5 volts maximum will be adequate to run the parts needed. Testing of the motor driver will also need to be done. Looking at the input and output voltage of this driver you can verify the working parts are adequately supplied by the battery or solar panel. Lastly the current and voltages for the light emitting diodes were measured as well. These can easily be tested using a mobile digital multi-meter.

Once all power specifications were met through testing, testing the solar tracking sensor was then a vital part to ensure the microcontroller is receiving accurate data to be able to give the correct commands to the motors. The tracking sensor has 4 separate LDR's had to be tested multiple times with adjustments to the resistors to gain a maximum number of precision points.

## **8.5 Integration Testing**

After testing each individual part and making sure the design was running correctly, the final integration test was performed so the design was fully operational and functional. This was done after everything was built and assembled. This basically consisted of checking everything to make sure that all of the functions worked correctly and in unison. Things like pressing the push button to make sure that the umbrella would go through all of the lighting modes during entertainment mode. Pushing the button for the sun tracking mode and ensuring that it was working properly was another important test that was required.



## 9.0 Milestone and Budget

### 9.1 Senior Design I Milestone Chart

The milestone table in Table 9.1-1 shows the projected progression of the pre-prototype design section that was required to meet the deadline of Thursday, August 6th, 2015.

<b>May 18, 2015 - June 21, 2015</b>					
<b>Description</b>	<b>May 18 - May 24</b>	<b>May 25 - May 31</b>	<b>June 1 - June 7</b>	<b>June 8 - June 14</b>	<b>June 15 - June 21</b>
Project Topic Research					
Basic Research of Project Materials					
Project Report					
Circuitry Schematic					
Ordering of Parts					

<b>June 22, 2015 - July 26, 2015</b>					
<b>Description</b>	<b>June 22 - June 28</b>	<b>June 29 - July 5</b>	<b>July 6 - July 12</b>	<b>July 13 - July 19</b>	<b>July 20 - July 26</b>
Project Topic Research					
Basic Research of Project Materials					
Project Report					
Circuitry Schematic					
Ordering of Parts					

<b>July 27, 2015 - August 6, 2015</b>		
<b>Description</b>	<b>July 27 - Aug 2</b>	<b>August 3 - Aug 9</b>
Project Topic Research		
Basic Research of Project Materials		
Project Report		
Circuitry Schematic		
Ordering of Parts		

Table 9.1-1

## 9.2 Senior Design II Milestone Chart

The milestone table in Table 9.2-1 shows the projected progression of the prototype build required to meet the deadline of Tuesday, December 1st, 2015. The chart in Table 9.2.1 also shows the progression of the project for the period in between Senior design I and Senior Design II.

### August 10, 2015 - September 13, 2015

Description	Aug 10 - Aug 16	Aug 17 - Aug 23	Aug 24 - Aug 30	Aug 31 - Sept 6	Sept 7 - Sept 13
Ordering of Parts					
PCB design					
Circuit Build and Testing					
Sensor Design and Testing					
Motor Control and Testing					
Lighting Control and Testing					
Solar Panel Build and Testing					
Pole Build and Testing					
Final Testing					

### September 14, 2015 - October 18, 2015

Description	Sept 14 - Sept 20	Sept 21 - Sept 27	Sept 28 - Oct 4	Oct 5 - Oct 11	Oct 12 - Oct 18
Ordering of Parts					
PCB Design					
Circuit Build and Testing					
Sensor Design and Testing					
Motor Control and Testing					
Lighting Control and Testing					
Solar Panel Build and Testing					
Pole Build and Testing					
Final Testing					

**October 19, 2015 - November 22, 2015**

<b>Description</b>	<b>Oct 19 - Oct 25</b>	<b>Oct 26 - Nov 1</b>	<b>Nov 2 - Nov 8</b>	<b>Nov 9 - Nov 15</b>	<b>Nov 16 - Nov 22</b>
Ordering of Parts					
PCB Design					
Circuit Build and Testing					
Sensor Design and Testing					
Motor Control and Testing					
Lighting Control and Testing					
Solar Panel Build and Testing					
Pole Build and Testing					
Final Testing					

**November 23, 2015 - December 11, 2015**

<b>Description</b>	<b>Nov 23 - Nov 29</b>	<b>Nov 30 - Dec 6</b>	<b>Dec 7 - Dec 11</b>
Ordering of Parts			
PCB Design			
Circuit Build and Testing			
Sensor Design and Testing			
Motor Control and Testing			
Lighting Control and Testing			
Solar Panel Build and Testing			
Pole build and Testing			
Final Testing			

Table 9.2-1

We were able to stay within about two weeks from this schedule shown in figure 9.2-1. We ended up getting behind schedule mainly due to three issues we had during the testing and populating of the PCB's we ordered.

### **9.3 Budget**

A specified design budget was determined at the brainstorming portion of this design. The group decided on a strict \$650.00 design budget. This budget includes all components that will be used in this design, including the design of a PCB during the prototype build. This budget does not include labor or manufacturing cost which would increase the budget substantially. When designing this product, special consideration of how to keep manufacturing costs to a minimum, were also discussed. These decisions have had an effect on how the product was designed. Some of these changes include installation of an external enclosure to house all of the circuitry and the battery pack. This enables this enclosure to be manufactured in a simpler manner using less costly manufacturing methods. This decreases the labor involved thus decreasing the labor cost for the product. Most of the labor costs would then be needed to mount the motors, mount the LED's, mount the solar panel arrays, and for the wire running and connections. Some of these processes could also be done during the umbrella build which would further increase build efficiency. After the initial prototype is created and tested, a detailed final bill of materials can then be created. These materials can then be used to shop for lower prices directly from the manufacturers of these components. Also buying the components in bulk would drive the components costs lower. Utilizing all of these aspects would decrease the building cost of the manufactured product lower allowing room for a profit margin which could then be considered based on sales projections. The goal of the group is to manufacture this product at around a total cost of \$100.00. Lower cost models could also be considered that would increase the target market. By creating and designing a broad range of different types of patio/beach umbrellas and installing the features from the prototype, the group believes that the Smart Umbrella would be competitive in the patio furniture or beach umbrella market.

## 10.0 Bill of Materials

### 10.1 Main Components

The main components will be those components that make up the main part of the product design. Table 10.1-1 below shows the quantity needed. The part number of the part ordered. It also gives a small description of the part. Where it will be purchased from by the group and how much the item will cost with shipping added into the total.

#	quantity	product number	description	purchased from	cost
1	1	009150286	Room Essentials 7'5" round patio umbrella	Target	\$26.00
2	1	31005	Tenergy 7.2 v 5200ah Li_ion battery pack w/PCB	Battery Junction	\$47.04
3	3	48010	Solopower 1.25 watt CIGS solar cells (lot of 10)	ebay	\$91.06
4	2	Sy35ST26-0284A	7.4V 0.28A stepper motor	Robotshop	\$31.43
5	2	ROB-12779	EasyDriver Bipolar stepper motor driver	Amazon	\$16.00
6	24	HF5-W5590	5 mm cool white high flux LED	SuperBrightLEDs.com	\$14.16
7	1	BQ24123RHLR	2-cell LI-ion charge management IC	Mouser	\$5.04

Table 10.1-1

## 10.2 MPPT Components

This list of components is those that directly relate to the MPPT synchronous switching regulator. Table 10.2-1 shows the quantity ordered and the part number for each part. It also provides a small description for each part. Finally it shows where the part will be ordered from and the cost of that part including shipping.

#	quantity	model number	description	purchased from	cost
1	1	ACS	current sensor module	eBay	\$1.72
2	1	2004 LCD	20 x 4 LCD display module	eBay	\$8.64
3	4	CSD18503KCS	Texas Instrument power MOSFETS	Mouser	\$8.16
4	1	LM27222M/NOPB	MOSFET driver	Mouser	\$2.98
5	1	2N222	BJT transistor	Mouser	\$1.79
6	2	1N4148	switching signal diode	Mouser	\$1.12
7	4	UF4003	super fast recovery diode	Mouser	\$1.72
8	2	P6KE15A	12.8 volt TVS diode	Mouser	\$1.12
9	2	P6KE10A	8.55 volt TVS diode	Mouser	\$0.88
10	1	5505-RC	Bourns 100uH inductor 4.9A	Mouser	\$2.80
11	2	EEU-FC1A561	560uF capacitor 10V	Mouser	\$1.08
12	2	5 x 20 mm	5 x 20 mm 250V fuses	eBay	\$0.99
13	2	5 x 20 mm	5 x 20 mm fuse holder	eBay	\$1.99

Table 10.2-1

### 10.3 Circuitry Components

The last table 10.3-1 shows the remaining component parts that will be used in the product design. This table shows the quantity ordered and part number. It also provides a small description of the part. Finally, the location of where the part is ordered from and the cost with shipping included is also shown.

#	quantity	model number	description	purchased from	cost
1	1	DGS126	5 pcs 2 position screw terminal wire termination	eBAy	\$1.49
2	1	2.54mm	10 pcs female header pins	eBay	\$0.99
3	1	PBS-110	5 pcs on/ off push button switch	eBay	\$3.58
4	1	66-1801-5001	toggle on/off switch w/ weatherproof boot	eBay	\$4.99
5	1	14-T000214010824	USB type A Female connector breakout charging board module 5V	eBay	\$1.67
6	2	200R	200 ohm resistor	Mouser	\$0.06
7	1	220R	220 ohm resistor	Mouser	\$0.03
8	3	330R	330 ohm resistor	Mouser	\$0.09
9	3	5kR	5k ohm resistor	Mouser	\$0.09
10	1	10kR	10K ohm resistor	Mouser	\$0.03
11	2	470kR	470k ohm resistor	Mouser	\$0.06
12	1	0.1R	0.1 ohm resistor	Mouser	\$0.03
13	1	500R	500 ohm resistor	Mouser	\$0.03
14	1	18.7kR	18.7k ohm resistor	Mouser	\$0.03
15	1	95.3kR	95.3k ohm resistor	Mouser	\$0.03
16	2	SLR-343YY3F	Yellow LED through hole 3.1mm	Mouser	\$0.98
17	6	SLR-343PC3F	Green LED through hole 3.1mm	Mouser	\$3.36
18	1	1pF	1pF capacitor	Mouser	\$0.03
19	5	0.1uF	0.1uF capacitor	Mouser	\$0.15
20	1	0.22uF	0.22uF capacitor	Mouser	\$0.03
21	1	0.33uF	0.33uF capacitor	Mouser	\$0.03
22	3	10uF	10uF capacitor	Mouser	\$0.09
23	1	100uF	100uF capacitor	Mouser	\$0.03
24	1	103AT	thermistor	Mouser	\$1.13

Table 10.3-1

## 11.0 Conclusion

This paper shows the process behind building a product from scratch. The group first brainstormed a unique idea by designing a product that meets a specific customer need. Research was then done to see if there was a market for this type of product. Outdoor furniture sales are projected to reach \$4.4 billion dollars in 2015 according to a new report done by Global Industry Analysis, Inc. There is also no one company that dominates this market. This provides the Smart Umbrella a target market in which to thrive.

Next research was done on the features offered by competitors in this market. Some umbrella manufacturers offer many different types of features. None however offer all of the features that the Smart Umbrella provides. The prototype that was built contains all of the options that will be available, though different models of the Smart Umbrella will also be available to increase sales in different sections of this market. A detailed list of specifications was then created keeping in mind the multiple features and final outcome of the product that the group wanted to create. Features that include being easily transportable, lightweight, and easy to setup. These features also include a constant shading design that utilizes small stepper motors controlled by a microprocessor that tracks the sun's location and provides shading at any time of day or season. To provide a portable umbrella that could be used in any situation a solar panel array was built from individual solar cells to provide a means to power the design. A high powered storage battery was also be used for this purpose when the solar panels do not provide enough power to run the Smart Umbrella. To increase the efficiency a Maximum Power Point Tracking synchronous switching regulator was utilized to maintain maximum power output to the battery charging system and the load. This MPPT decreases the size of the solar panel needed and increases the power available. A USB dedicated charging port is also incorporated into the design to allow connectivity in any environment. This along with multiple LED's, light up any situation allowing the user to enjoy this product in any situation.

The group then began designing the circuitry involved in making the Smart Umbrella a reality. This includes designing a MPPT synchronous switching regulator and the complete power system circuitry that was required. After many hours of research on the vast amount of components in the market today,, components were chosen based on their efficiency. User friendly circuit indicators were also designed so that the user can, at a glance, be able to see the charging status using a series of three LED's and the status of the solar panel and battery system using an LCD screen. A complete schematic was then created using Eagle Cad software. This schematic was used to create a PCB that decreased the amount of space needed by the circuitry. This PCB also added durability and dependability to the circuit design. It also made the presentation of the circuitry more professional.



The group then presents ideas on how to control the many different parts of the product. The microcontroller needed to take data from multiple group designed sensors and output data to the many different controllable systems incorporated in the design. First the microcontroller needed to collect the data from two voltage sensors and a current sensor to adjust the PWM to the synchronous switching regulator using a MPPT algorithm that was coded by the group members. This data was also displayed on the LCD screen for easy user friendly system status reports. The microcontroller also takes data from the group designed sensors that track the sun's location and output a control signal to both of the motors that will be used in the design to allow the constant shading feature. The LED's that are incorporated into the design will also need to be controlled by the microprocessor to turn on in low lighting conditions. The entertainment mode will need to be controlled as well to provide the customer with a rotating flashing LED configuration that will be the focal point of any conversation when it is used. This adds a fun factor to the design and creates a unique design feature unmatched by any other product in the market.

The group then considers and discusses how the parts will be properly mounted to create a long lasting product that could be used for years. This involves the building of solar panels from individual solar cells and showing how to properly encapsulate the cells to make them weather resistant and how to mount these panels in a visually pleasing way to the top of the Smart Umbrella. This also involves the mounting and weatherproofing of the multiple LED's that will be used in the design in a uniform manner that maximizes the lighting output. Proper wire routing and weatherproofing has also been considered. Motor mounting and motor torque ratios were then discussed in detail. The motors will need to be mounted in a non-restricting manner that is also visually pleasing to the user. Ideas for where to place the circuitry and battery pack have also been discussed, as well as, how to properly mount this enclosure to the pole of the umbrella. All of these parts need to be properly mounted to maintain the life expectancy that the group wishes to achieve. Special consideration of how to access the battery pack for easy replacement during user maintenance was also discussed.

A detailed Bill of Materials (BOM) was then created. A projected timeline for final prototyping of the design was also considered in this paper. This shows the projected weekly progress by the group members to achieve the build of the prototype in the time allowed. ABET real world constraints were considered by giving multiple examples of how these real world constraints could affect the design process. Ideas on how to final test the prototype and expected outcomes of the testing process are also discussed in this paper. This is important for showing that the product will maintain the projected life time projected by the group. This design process shows the capability of the group to create, design, and build a prototype of a major project using skills that have been taught to us over many years of schooling. This gives us the experience and confidence of creating a product from scratch considering many real world aspects that may affect the design.

## References

Direct, Eco. "MPPT vs PWM charge controllers by Blue Sky, Morningstar, Outback, and Xantrax.", accessed on 6/25/2015, <http://www.ecodirect.com/Charge-Controller-Comparison-s/251.htm>

Electronics, Power. "Buck Converter Design Demystified", accessed 7/4/2015, <http://powerelectronics.com/dc-dc-converters/buck-converter-design-demystified>

Informative, Energy. "Best thin film solar panels - Amorphous, Cadmium Telluride, or CIGS?", accessed 6/21/2015, <http://energyinformative.org/best-thin-film-solar-panels-amorphous-cadmium-telluride-cigs/>

Informative, Energy. "Which solar panel type is best? Mono- vs. Polycrystalline vs thin film", accessed 6/21/2015, <http://energyinformative.org/best-solar-panel-monocrystalline-polycrystalline-thin-film/>

Network, EDN. "A simple guide to selecting power MOSFETS", accessed 7/3/2015, <http://www.edn.com/design/components-and-packaging/4341997/A-simple-guide-to-selecting-power-MOSFETs>

Semiconductor, On. "AND9135 - LC Selection Guide for the DC-DC Synchronous Buck Converter", accessed 7/3/2015, [http://www.onsemi.com/pub\\_link/Collateral/AND9135-D.PDF](http://www.onsemi.com/pub_link/Collateral/AND9135-D.PDF)

Solar, Tindor. "Poly vs Mono crystalline" accessed 6/21/2015, <http://www.tindosolar.com.au/poly-vs-mono-crystalline/>

University, Battery. "Advantages and disadvantages of different types of batteries", accessed 6/19/2015, [http://batteryuniversity.com/learn/article/whats\\_the\\_best\\_battery](http://batteryuniversity.com/learn/article/whats_the_best_battery)

Voltage, Reference. "MOSFET selection for Buck Converters", accessed 7/3/2015, <http://referencevoltage.com/?p=348>

Wind & Sun, Northern Arizona. "Solar Charge Converter Basics", accessed 6/26/2015, <http://www.solar-electric.com/solar-charge-controller-basics.html>

Engineering, Learning. "DC Motor, How it works ?", accessed 7/13/2015, <http://www.learnengineering.org/2014/09/DC-motor-Working.html>

Engineering, Learning. "Brushless DC Motor, How it works ?" accessed 7/13/2015, <http://www.learnengineering.org/2014/10/Brushless-DC-motor.html>

Omega. "INTRODUCTION TO STEP MOTORS" accessed 07/13/2015, [https://www.omega.com/auto/pdf/REF\\_IntroStepMotors.pdf](https://www.omega.com/auto/pdf/REF_IntroStepMotors.pdf)

Adafruit. "Types of Steppers" accessed 07/14/2015, <https://learn.adafruit.com/all-about-stepper-motors/types-of-steppers>

Adafruit. "All about Stepper Motors" accessed 07/14/2015, <https://learn.adafruit.com/downloads/pdf/all-about-stepper-motors.pdf>

Engineering, Lin. "A Simple Tutorial for Common Stepper Terminology" accessed 07/14/2015, [http://www.linengineering.com/contents/steptomors/pdf/Step\\_Motor\\_Basics.pdf](http://www.linengineering.com/contents/steptomors/pdf/Step_Motor_Basics.pdf)

Wikipedia, "USB" accessed 7/15/2015, <https://en.wikipedia.org/wiki/USB>

Integrated, Maxim, "The Basics of USB Battery Charging: A Survival Guide", accessed 7/15/2015, <http://www.maximintegrated.com/en/app-notes/index.mvp/id/4803>

Bulbs. "Incandescent Bulbs" accessed 07/22/2015 <http://www.bulbs.com/learning/incandescent.aspx>

ies. "discover LIGHTING an introduction to lighting basics" accessed 07/22/2015, <http://www.ies.org/lighting/>

EE|Times. "A tradeoff between microcontroller, DSP, FPGA and ASIC technologies" accessed 07/13/2015, [http://www.eetimes.com/document.asp?doc\\_id=1275272](http://www.eetimes.com/document.asp?doc_id=1275272)

Wikipedia, "Field-programmable gate array" accessed 7/14/15 [https://en.wikipedia.org/wiki/Field-programmable\\_gate\\_array](https://en.wikipedia.org/wiki/Field-programmable_gate_array)

Microchip, "Practical Guide to Implementing Solar Panel MPPT Algorithms" accessed 7/14/15 <http://ww1.microchip.com/downloads/en/AppNotes/00001521A.pdf>

Wikipedia, "Current sensor" accessed 7/15/15 [https://en.wikipedia.org/wiki/Current\\_sensor](https://en.wikipedia.org/wiki/Current_sensor)

Suntracker, "How I built a motorized sun tracker for my solar panels" accessed 7/15/15 <http://www.mdpub.com/suntracker/>

ElectronicsTutorials, "Light Sensors" accessed 7/15/15 [http://www.electronics-tutorials.ws/io/io\\_4.html](http://www.electronics-tutorials.ws/io/io_4.html)

Atmel, "Atmel ATmega640/V-2560" accessed 7/16/15

[http://www.atmel.com/images/atmel-2549-8-bit-avr-microcontroller-atmega640-1280-1281-2560-2561\\_datasheet.pdf](http://www.atmel.com/images/atmel-2549-8-bit-avr-microcontroller-atmega640-1280-1281-2560-2561_datasheet.pdf)

Hairul Nissah Zainudin, "Comparison study of Maximum Power Point Tracker Techniques for PV Systems" accessed 7/16/15  
<http://core.ac.uk/download/pdf/11438597.pdf>

Rickey's World, "Stepper Motor Tutorial" accessed 7/16/15  
[http://www.8051projects.net/wiki/Stepper\\_Motor\\_Tutorial](http://www.8051projects.net/wiki/Stepper_Motor_Tutorial)

# Appendix A - Copyright Permission

## Figures 4.3.1-1, 4.3.1-2, 4.8.1-1, 4.8.1-2, 4.5.2-1, 4.5.2-2, 4.5.3-2, 6.1.1-1 Permission

**Important note:** The Wikimedia Foundation does not own copyright on Wikipedia article texts and illustrations. It is therefore pointless to email our contact addresses asking for permission to reproduce articles or images, even if rules at your company or school or organization mandate that you ask web site operators before copying their content.

The only Wikipedia content you should contact the Wikimedia Foundation about is the trademarked Wikipedia/Wikimedia logos, which are not freely usable without permission.

Permission to reproduce and modify text on Wikipedia has already been granted to anyone anywhere by the authors of individual articles as long as such reproduction and modification complies with licensing terms (see below and [Wikipedia:Mirrors and forks](#) for specific terms). Images may or may not permit reuse and modification; the conditions for reproduction of each image should be individually checked. The only exceptions are those cases in which editors have violated Wikipedia policy by uploading copyrighted material without authorization, or with copyright licensing terms which are incompatible with those Wikipedia authors have applied to the rest of Wikipedia content. While such material is present on Wikipedia (before it is detected and removed), it will be a copyright violation to copy it. For permission to use it, one must contact the owner of the copyright of the text or illustration in question; often, but not always, this will be the original author.

If you wish to reuse content from Wikipedia, first read the [Reusers' rights and obligations](#) section. You should then read the [Creative Commons Attribution-ShareAlike 3.0 Unported License](#) and the [GNU Free Documentation License](#).

## Figure 5.1.3-1, 5.1.4-1, 5.2.1-1 Permission

### [Use Restrictions and Termination of Access to TI Services](#)

TI Services on this site are protected by copyright laws, international copyright treaties, and other intellectual property laws and treaties. Except as stated herein, no TI Service, nor any part of any TI Service, may be reproduced, duplicated, mirrored, modified, displayed, distributed, copied, sold, resold, visited, or otherwise exploited for any purpose without express prior written consent of TI.

You agree not to use TI Services in a manner that violates any applicable law or regulation; to stalk, harass, or harm another individual; to impersonate any person or entity or otherwise misrepresent your affiliation with a person or entity; to interfere with or disrupt TI Services or servers or networks connected to TI Services; use any data mining, robots, or similar data gathering or extraction methods in connection with TI Services; frame or utilize framing techniques to enclose any trademark, logo, proprietary, or other information (including datasheets, images, text, page layout, or form); and attempt to gain unauthorized access to any portion of TI Services or any other accounts, computer systems, or networks connected to TI Services, whether through hacking, password mining, or any other means.

Subject to any Service Terms that may apply, TI grants you permission to download, reproduce, display, and distribute TI Services on this site solely for non-commercial or personal use, provided that you do not modify such TI Services, and provided further that you retain all copyright and proprietary notices as they appear in such TI Services.

TI further grants to K-12 educational institutions, universities, and community colleges permission to download, reproduce, display, and distribute TI Services on this site solely for use in the classroom, provided that such institutions identify

TI as the source of TI Services and include the following credit line: “Courtesy of Texas Instruments.” Unauthorized use of any TI Service is expressly prohibited by law, and may result in civil and criminal penalties. This grant of permission terminates if you breach any provision in these Terms of Use or Service Terms. Upon termination, you agree to destroy any materials relating to TI Services obtained from this site.

TI reserves the right, in its sole discretion, to terminate, suspend, or modify your registration with, or access to, all or any part of TI Services, without notice, at any time and for any reason.

### Figure 5.1.1-1, 8.3-1, 8.3-2 Permission

Original message sent yesterday by [mcdon20](#)

Hello deba168,

I am an electrical engineering student at the University of Central Florida who is in the process of creating my capstone project for graduation. My project will use solar panels to charge batteries, as well as, run two small motors and an FPGA board to control these motors and some led lighting. I am writing to you because after researching MPPT's for the past two weeks I was beginning to think that creating my own MPPT might be a bit over my head. After reading your detailed instructions on how you built your design, I now fully understand the process of creating an MPPT for my project. I would like to use your design as a base for my own design. I have read the license agreement on the website and understand that I can not use this design for commercial purposes and that I need to credit you, the designer, in all of my documentation. I have also read that I have to provide the licensing symbol on my documentation and agree to the same licensing restrictions. I was writing to you to first thank you for posting this information on instructables as it has been a great learning experience for me. I was also wanting to get written permission from you personally to use your design as a base for my own design. I may need to redesign it a bit to fit my own application and will probably be putting this on a PCB board as it will be needed to fit into a smaller packaging. I was also wanting to get written permission to include a few of your pictures from this website in my documentation. Mainly the block diagram showing the power and control lines going to each block. I will of course be very happy to cite you and this website for any pictures that I use as well as for the basis of my MPPT design.

Thank you

mcdon20

[Block this user](#)

from:  [PRO deba168](#)

when: Jun 15, 2015, 7:49 AM

subject: re: ARDUINO MPPT SOLAR CHARGE CONTROLLER (Version-3.0) by de...

Hello mcdon20,

If you are using it for educational/research purposes, I have no problem at all,you can feel free to use it.You can use my pictures also.

As long as it is used for educational use no need for written authorisation.So I can't give you any written authorisation for it.

Thanks

deba168

### Figure 5.5-1 Permission

EasyDriver by [Brian Schmalz](#) is licensed under a [Creative Commons Attribution 3.0 United States License](#).

You are free to:

- **Share** — copy and redistribute the material in any medium or format
- **Adapt** — remix, transform, and build upon the material for any purpose, even commercially.

The licensor cannot revoke these freedoms as long as you follow the license terms.

#### **Figure 5.5-2, and 5.5-3 Permission**

Easy Driver Hook-up Guide by TONI\_K is licensed under a [Creative Commons Attribution NonCommercial-ShareAlike 3.0 Unported](#).

You are free to:

- **Share** — copy and redistribute the material in any medium or format
- **Adapt** — remix, transform, and build upon the material

The licensor cannot revoke these freedoms as long as you follow the license terms.

#### **Figure 4.4.1-1, 4.4.1-2, 4.4.1-3, 4.4.1-4, 4.4.1-5, 4.4.1-6, 4.4.2-1, 4.4.2-2 Permission**

Types of MPPT Algorithms by Rickey's World is licensed under a [Creative Commons Attribution NonCommercial-ShareAlike](#).

You are free to:

- **Share** — copy and redistribute the material in any medium or format
- **Adapt** — remix, transform, and build upon the material

The licensor cannot revoke these freedoms as long as you follow the license terms.

#### **Figure 5.3-2, 5.3-3, 6.3-1, and 6.3-2 Permission**

AVR Architecture by AVR is licensed under a [Creative Commons Attribution NonCommercial-ShareAlike](#).

You are free to:

- **Share** — copy and redistribute the material in any medium or format
- **Adapt** — remix, transform, and build upon the material

The licensor cannot revoke these freedoms as long as you follow the license terms.

#### **Figure 6.2-1 and 6.2-2 Permission**

Microcontroller controlling Bi-polar stepper motor is licensed under a [Creative Commons Attribution NonCommercial-ShareAlike](#)

You are free to:

- **Share** — copy and redistribute the material in any medium or format
- **Adapt** — remix, transform, and build upon the material

The licensor cannot revoke these freedoms as long as you follow the license terms.

## Appendix B - Datasheets

Sy35ST26-0284A High Torque Hybrid Stepping Motor Specifications

<https://www.pololu.com/file/0J690/SY35ST26-0284A.pdf>

ROB-12779 Easy Driver Hook-up Guide

[http://media.digikey.com/pdf/Data%20Sheets/Sparkfun%20PDFs/EasyDriver\\_Ho okup\\_Guide\\_Web.pdf](http://media.digikey.com/pdf/Data%20Sheets/Sparkfun%20PDFs/EasyDriver_Ho okup_Guide_Web.pdf)

**HF5-W5590** 5mm Pure White High Flux LED

<https://www.superbrightleds.com/moreinfo/through-hole/5mm-pure-white-high-flux-led-90-degree-viewing-angle-5500-mcd/705/1980/#/tab/Specifications>

AtMega 2560 8-bit Atmel Microcontroller with 16/32/64KB In-System Programmable Flash

[http://www.atmel.com/images/atmel-2549-8-bit-avr-microcontroller-atmega640-1280-1281-2560-2561\\_datasheet.pdf](http://www.atmel.com/images/atmel-2549-8-bit-avr-microcontroller-atmega640-1280-1281-2560-2561_datasheet.pdf)

1N4148 Small Signal Fast Switching Diodes

<http://www.vishay.com/docs/81857/1n4148.pdf>

5505-RC 100 uH inductor

[www.bourns.com/pdfs/5500\\_series.pdf](http://www.bourns.com/pdfs/5500_series.pdf)

EEU-FC1A561 560 uF capacitor

<http://www.alliedelec.com/images/products/datasheets/bm/Panasonic/70068429.pdf>

ACS712 Fully Integrated, Hall Effect-Based Linear Current Sensor IC with 2.1 kVRMS Isolation and a Low-Resistance Current Conductor

<http://www.digikey.com/catalog/en/partgroup/acs712/10334?WT.srch=1&mkwid=sPM0hiPSp&pcriid=71244856275&pkw=cat%3Adigikey.com&pmt=b&pdv=c>

BQ24123 SINGLE-CHIP SWITCHMODE, LI-ION AND LI-POLYMER CHARGE-MANAGEMENT IC WITH ENHANCED EMI PERFORMANCE(bqSWITCHER™)

<http://www.ti.com/lit/ds/slus688g/slus688g.pdf>

CSD18503KCS CSD18503KCS 40 V N-Channel NexFET™ Power MOSFET

<http://www.ti.com/lit/ds/symlink/csd18503kcs.pdf>

LM27222 High-Speed 4.5A Synchronous MOSFET Driver

<http://www.farnell.com/datasheets/1803523.pdf>

P6KE18A Transil™, transient voltage surge suppressor (TVS)

<http://www.farnell.com/datasheets/1670954.pdf>



UF4003 UF4001 – UF4003 fast rectifiers  
<https://www.fairchildsemi.com/datasheets/UF/UF4003.pdf>