

Helicopter Collective Control for Flight Simulators

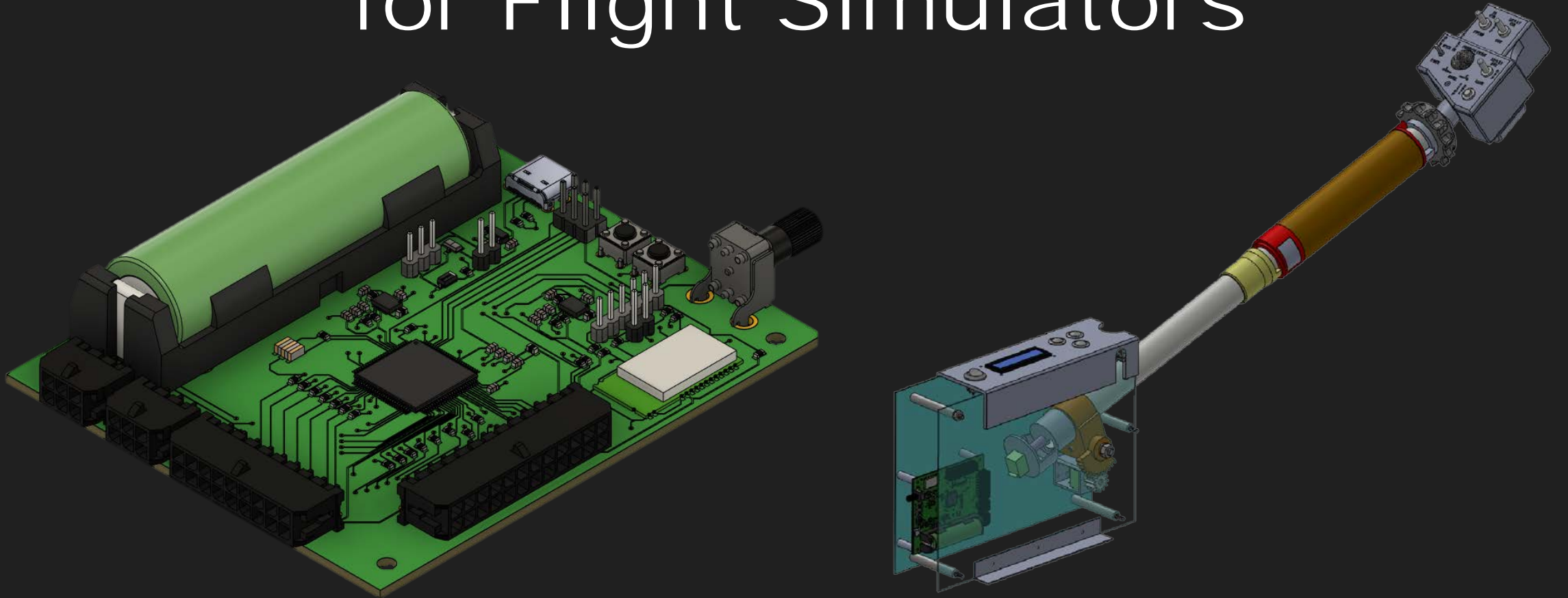

Group 20 - 6/17/2021

Meet the Team

David Green
B.S. Computer Engineering



Mark Green
B.S. Computer Engineering



Sven Hall
B.S. Computer Engineering

Picture Omitted

Joseph Pergola
B.S. Electrical Engineering



Helicopter Collective Control

- Three main helicopter controls
 - Pedals control direction which the nose points (yaw)
 - Cyclic controls movement in horizontal axis
 - Collective Control consists of throttle and lever
 - Throttle controls engine power/rotor speed
 - Lever controls movement in vertical axis
 - Changes angle of all main rotor blades simultaneously
 - Affects amount of lift generated by the blades

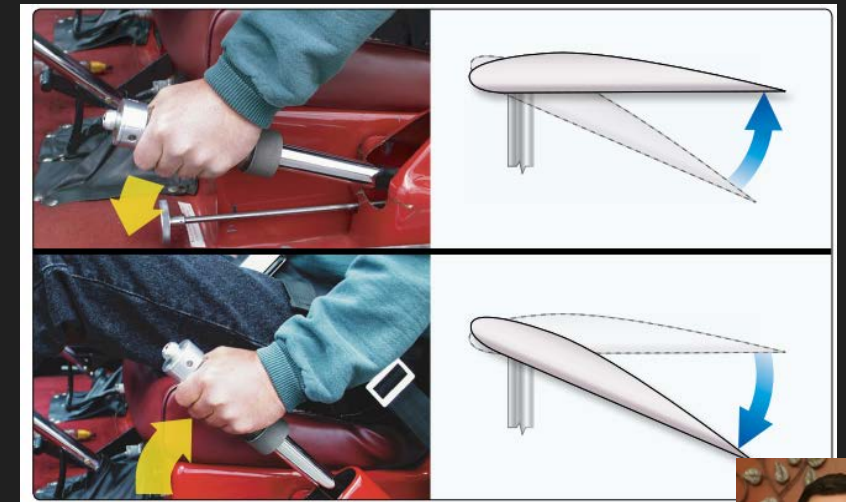
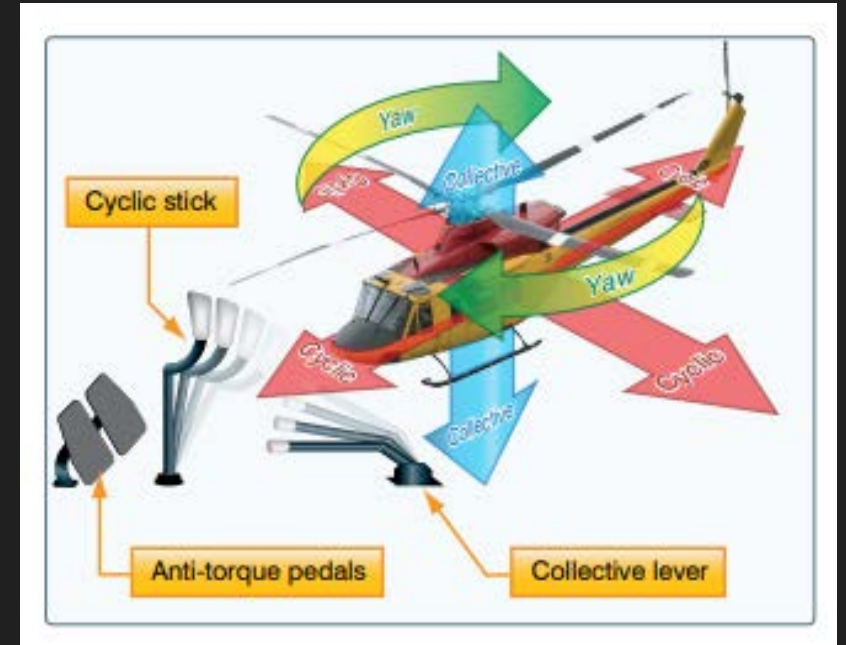

David

Motivation

- Consumer flight simulation products tailored toward airplane controls
 - More familiar to the average user of flight simulation software
 - Results in a relative lack of options for flight simulation equipment for more niche flight controls such as a helicopter collective
- Current options for helicopter-specific flight simulation controls tend to be rather expensive, often thousands of dollars



Logitech X52
H.O.T.A.S., a typical
throttle-and-stick control
for airplane flight sims

Copyright Requested for
image



Mark

Goals and Objectives

- Relatively low cost
 - Extensive use of 3D printing for mechanical structure
- Portable
 - Simple bracket mounting system, rechargeable battery power, wireless Bluetooth communication
- Accurate
 - High resolution absolute rotary encoders to measure angular position of physical parts
- Modular
 - Include a way to easily swap out collective heads to represent different helicopters



Specifications

1	Cost	< \$500
2	Weight	< 20 lbs.
3	Line of Sight Wireless Connection Range	≥ 15 ft
4	Idle Runtime (Wireless)	> 10 hours
5	Collective Base Size	< 1 cu. ft
6	Minimum Measurable Change of Lever Angle	< 1°
7	Angular Variance at Idle	$\pm 5\%$ of total angular travel
8	Number of Unique Collective Heads	≥ 2 Heads
9	Angular Poll Rate	≥ 3 Hz
10	Collective Lever Angular Travel Range	$\geq 30^\circ$
11	Calibrated Digital Output Range	Min: 0, Max: 1023
12	Operating System Compatibility	Windows 10



Electrical Hardware Design



David

Hardware Block Diagram

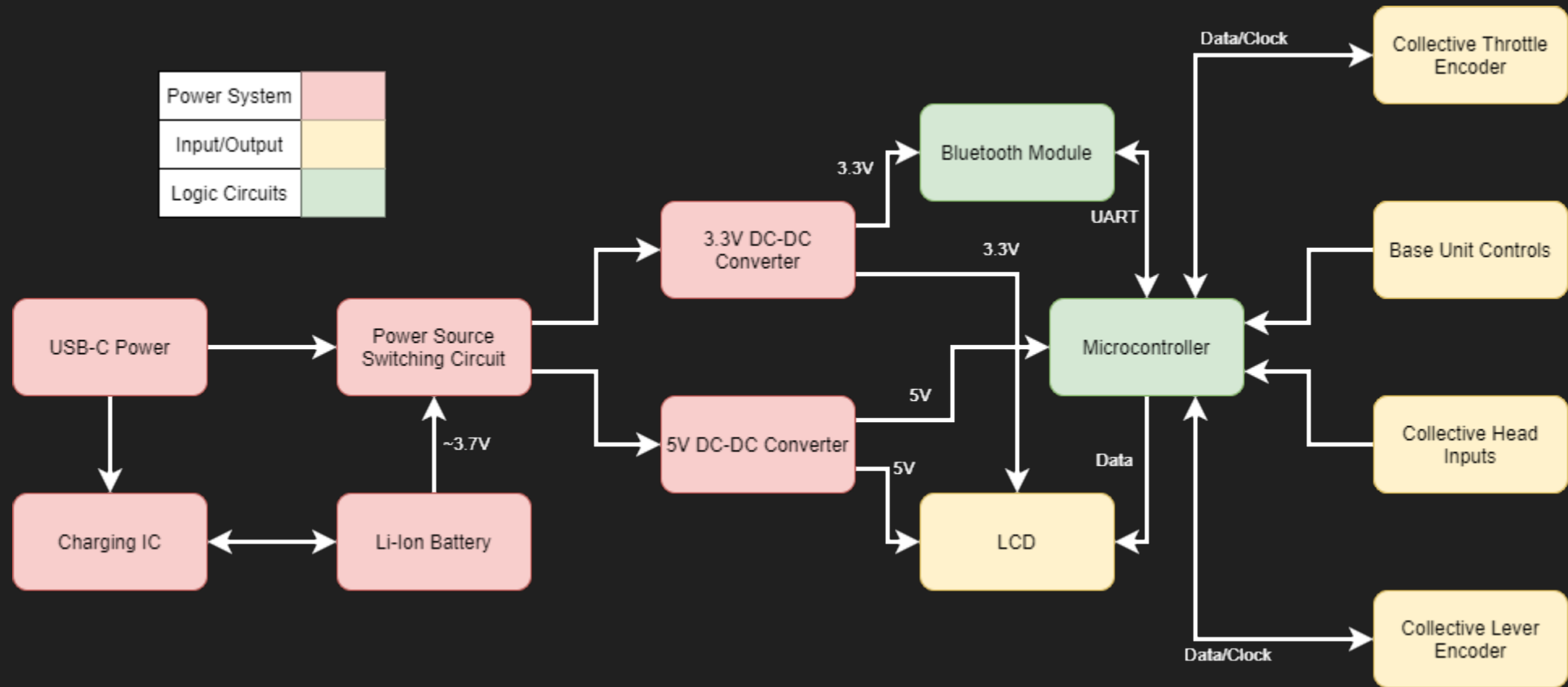

ATmega2560 Microcontroller

- 16 MHz clock allows for seemingly instantaneous response to user input
- 86 GPIO pins accommodates large number of inputs
 - Collective head and top panel require significant number of GPIO pins
 - Number of inputs varies per head
- 4KB EEPROM allows for persistent calibration data
- UART capability required to interface with Bluetooth Module
- Available on Arduino Mega 2560 development board for effective prototyping and development

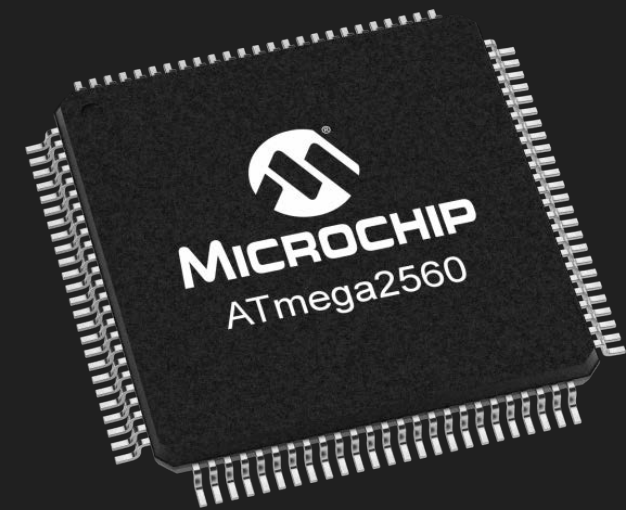

Clock Speed	16 MHz
Memory & Storage	256KB Flash, 4KB EEPROM, 8KB SRAM
Number of GPIO Pins	86 (digital, analog, and USART/I2C capable)



David

Human Interface Devices (HIDs)

- Human Interface Devices (HIDs) are a class of devices which adhere to the USB HID definition
 - HID definition describes the protocol for input/output devices to interface with a host device
 - Most common computer peripherals are an HID (mouse, keyboard, game controller, etc.)
- HID over GATT is a profile established by the Bluetooth SIG which defines how to implement HID via Bluetooth Low Energy
 - HID over GATT is essential as it converts raw data sent from the collective into inputs which are understood by the host computer
- Helicopter simulation software almost universally has support for generic HID devices
 - The collective will send data which is interpreted as two axes inputs as well as a collection of button inputs, which are then mapped in the simulation software to their corresponding actions



BM70 Bluetooth Module

- Fully Integrated Bluetooth Software Stack
 - Bluetooth Low Energy capability reduces power consumption
 - Bluetooth 5.0 is most modern specification
 - Full control over Bluetooth stack allows for HID implementation
- Integrated antenna and shield provides drop-in Bluetooth functionality
 - No need for externally connected or PCB mounted antenna
 - Factory design is shielded and certified in a variety of markets
- UART Interface allows for easy microcontroller connection
 - After configuring Bluetooth module, simple byte commands can be passed over UART between ATmega2560 and BM70 to facilitate Bluetooth communication
- Manufacturer provided software allows for ease of configuration and testing



Bluetooth Version	5.0
Wireless Range	50m
Software Interface	UART



David

EMS22A50 Rotary Encoder

- 1024 positions across 360 degrees of travel
 - 1024 positions provides accuracy of 0.35 degrees per step
- Absolute style encoder maintains position across power cycles
 - Magnetic mechanism increases lifespan and feel as compared to physical mechanism
- Panel mount allows for simple integration into mechanical design



Resolution	1024 positions
Accuracy (nominal)	+/- 0.7 degrees
Mounting Style	Panel Mount
Encoder Style	Absolute (magnetic)
Rotation	360 degrees, continuous



Molex Connectors

- Molex connectors allow for ease of assembly and cable management
 - Provide a more professional product feel
 - 17 pin Molex connector facilitates the quick-detach head mechanism
- Variety of mounting styles allow for flexible usage
 - 17 pin Molex connector is panel mounted and can be integrated directly into the collective lever
 - 6, 18, and 24 pin connectors are PCB mounted to connect top panel, head inputs, and encoders



Mounting Style	PCB Mount & Panel Mount
Number of Pins	6, 17, 18, 24
Attachment Style	Friction, clip



Electrical Hardware Schematics

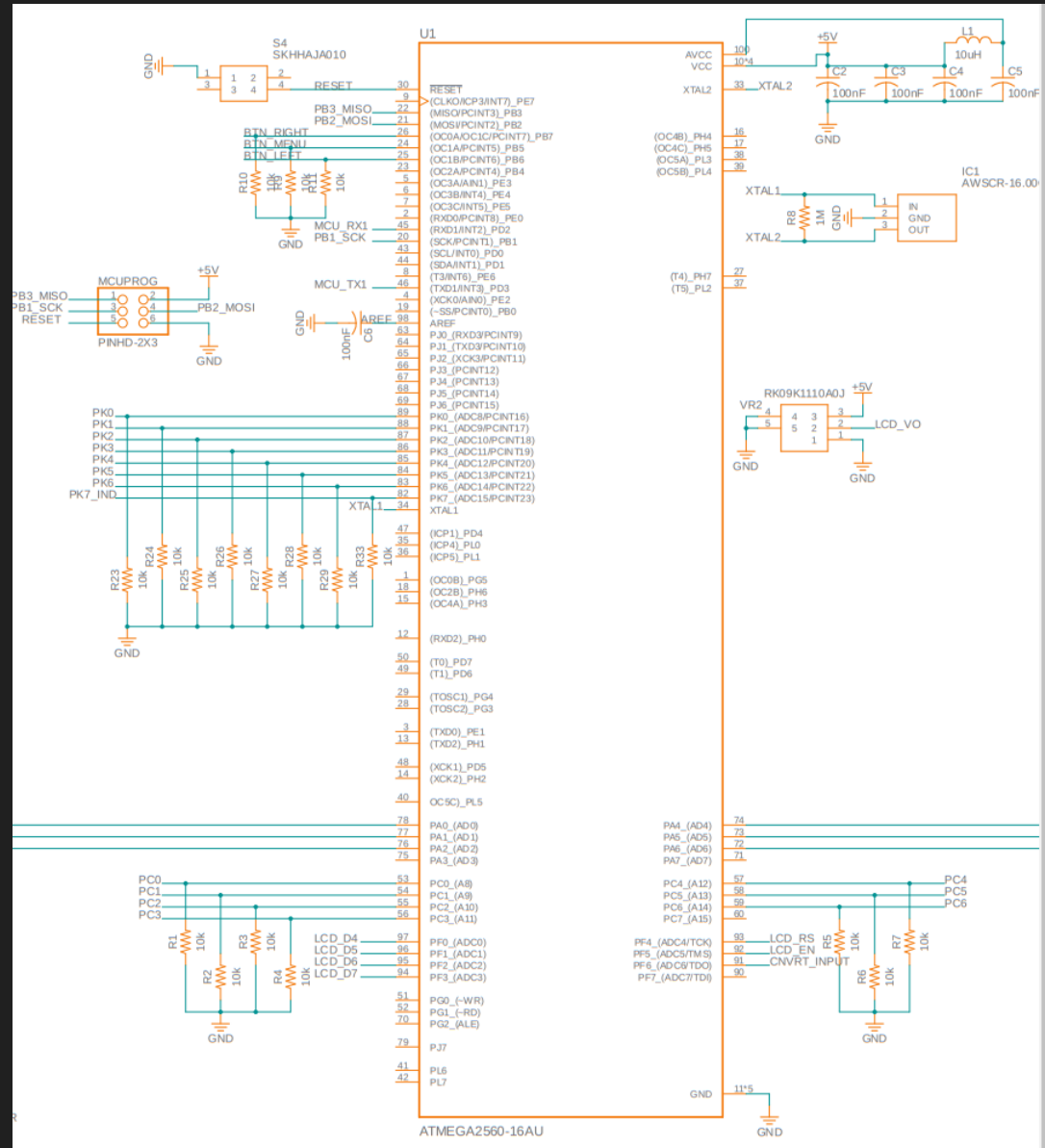
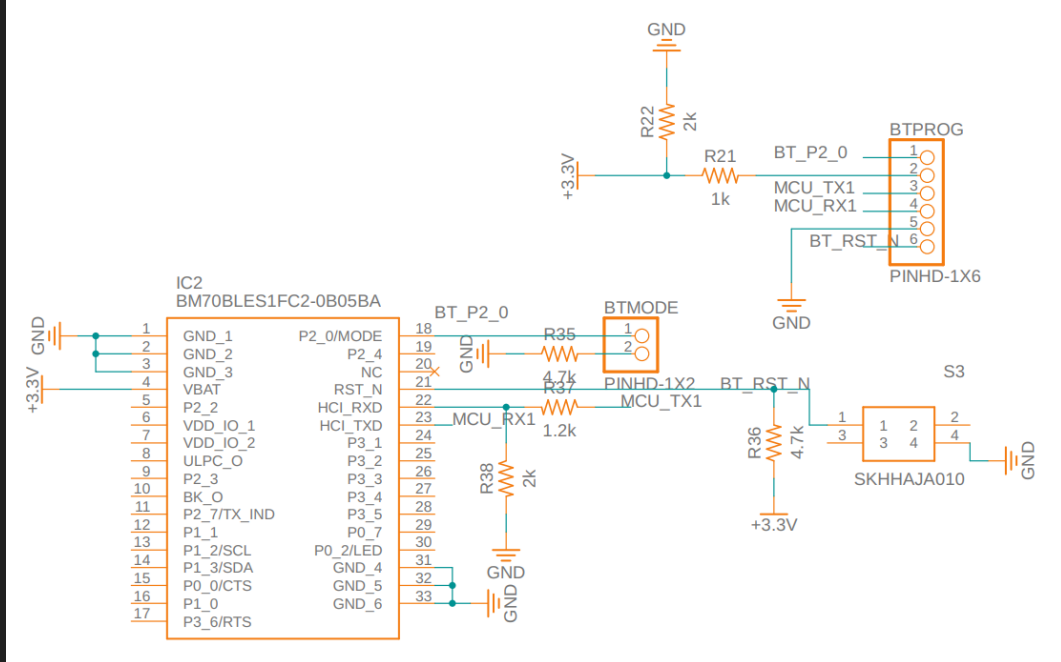
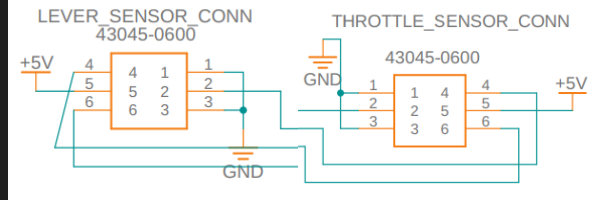
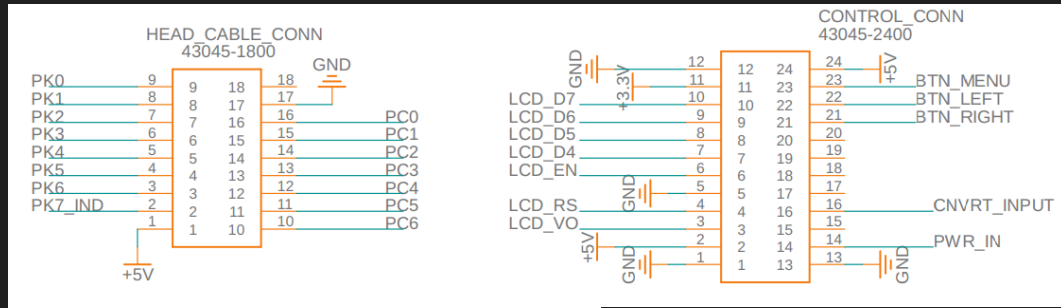

Power Design



Joseph

Power System

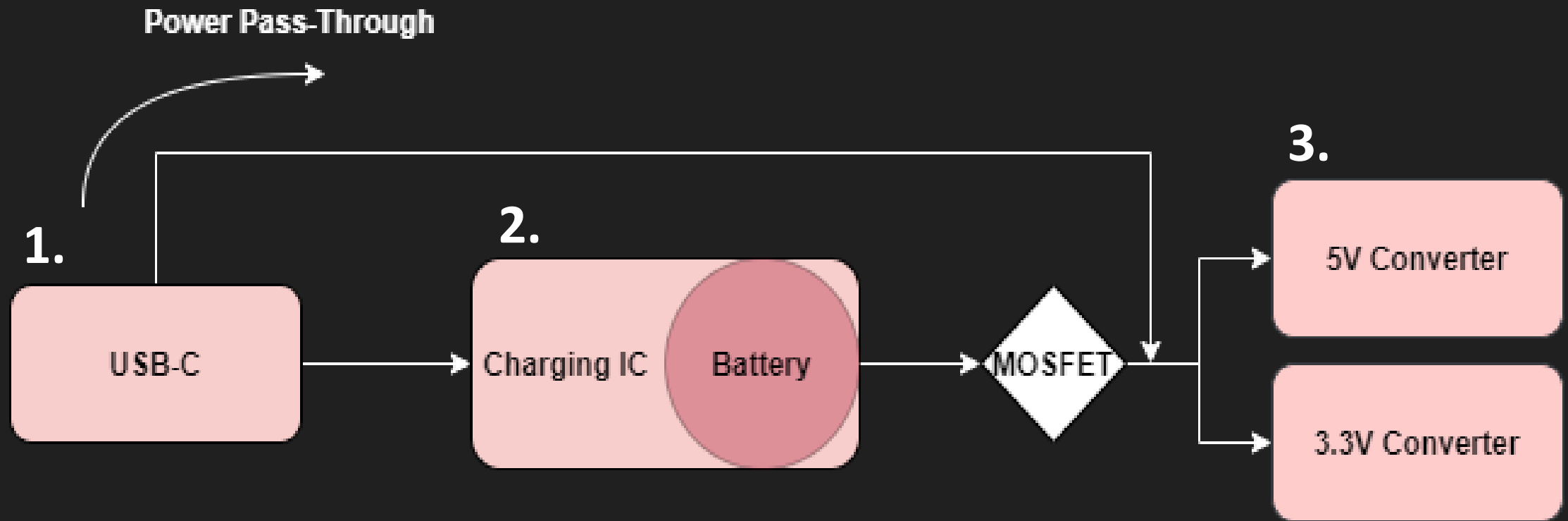

Joseph

18650 Li-Ion Battery

- Rechargeable Battery suitable for portable applications
- Li-Ion Battery and its advanced technology, providing:
 - Long Life-Cycles
 - Fast Charging
 - High Energy Density

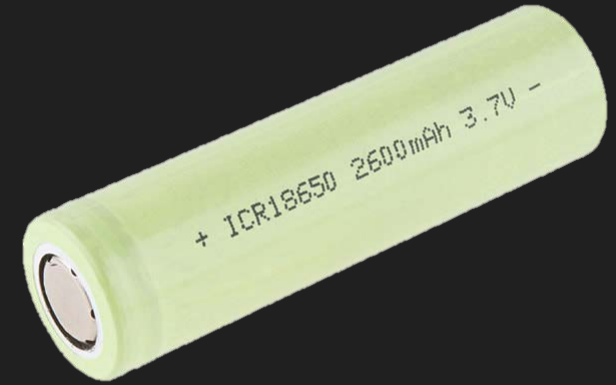

Nominal Voltage	3.6V
Voltage Range	2.5V – 4.2V
Capacity Range	~2300-4000 mAh



Joseph

MCP73831 Charging IC

- Small, affordable, and low number of external components required
- Maximum voltage charge of 4.2V, which maintains a safe limit for the battery
- Suitable input voltage range and programmable output charging current range, considering voltage and current requirements for battery and system.
- Safety Features Considered
 - Charge Termination
 - Thermal Regulation



Max. Charge Voltage	4.2V
Input Voltage Range	3.75V – 6V
Programmable Charging Current Range	15mA – 500mA
Charge Termination	7.5% of programmed charge current
Thermal Regulation	Shut-off at 150°C



Joseph

TPS63020

Buck-Boost Converter

- Buck & Boost Converter allows flexibility in stepping-up and stepping-down voltage
- Promising input voltage range which will ensure required voltage outputs even at very low voltage levels
- Suitable programmable output voltage range that satisfies project requirements
- Supports up to 4A of output current, which is more than enough for our project



Input Voltage Range	1.8V – 5.5V
Selectable Output Voltage Range	1.2V – 5.5V
Max. Output Current	4A



Joseph

USB-C

- Popular design and advanced technology
 - Fast charging & data transfer
 - High power capabilities
 - Supports USB-PD



Design	Reversible
Voltage	5V
Max. Current	3A
Supports USB-PD for higher power options	Max:100W



Joseph

USB-C

- Popular design and advanced technology
 - Fast charging & data transfer
 - High power capabilities
 - Supports USB-PD

Power Pass-Through

- Redirects power delivery flow
- Allows battery to peacefully charge



Design	Reversible
Voltage	5V
Max. Current	3A
Supports USB-PD for higher power options	Max:100W

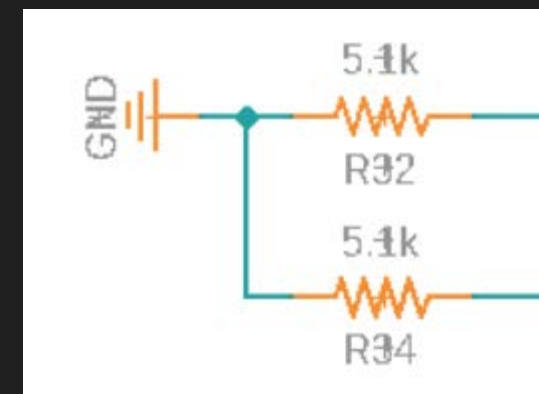

Joseph

Overall Schematic

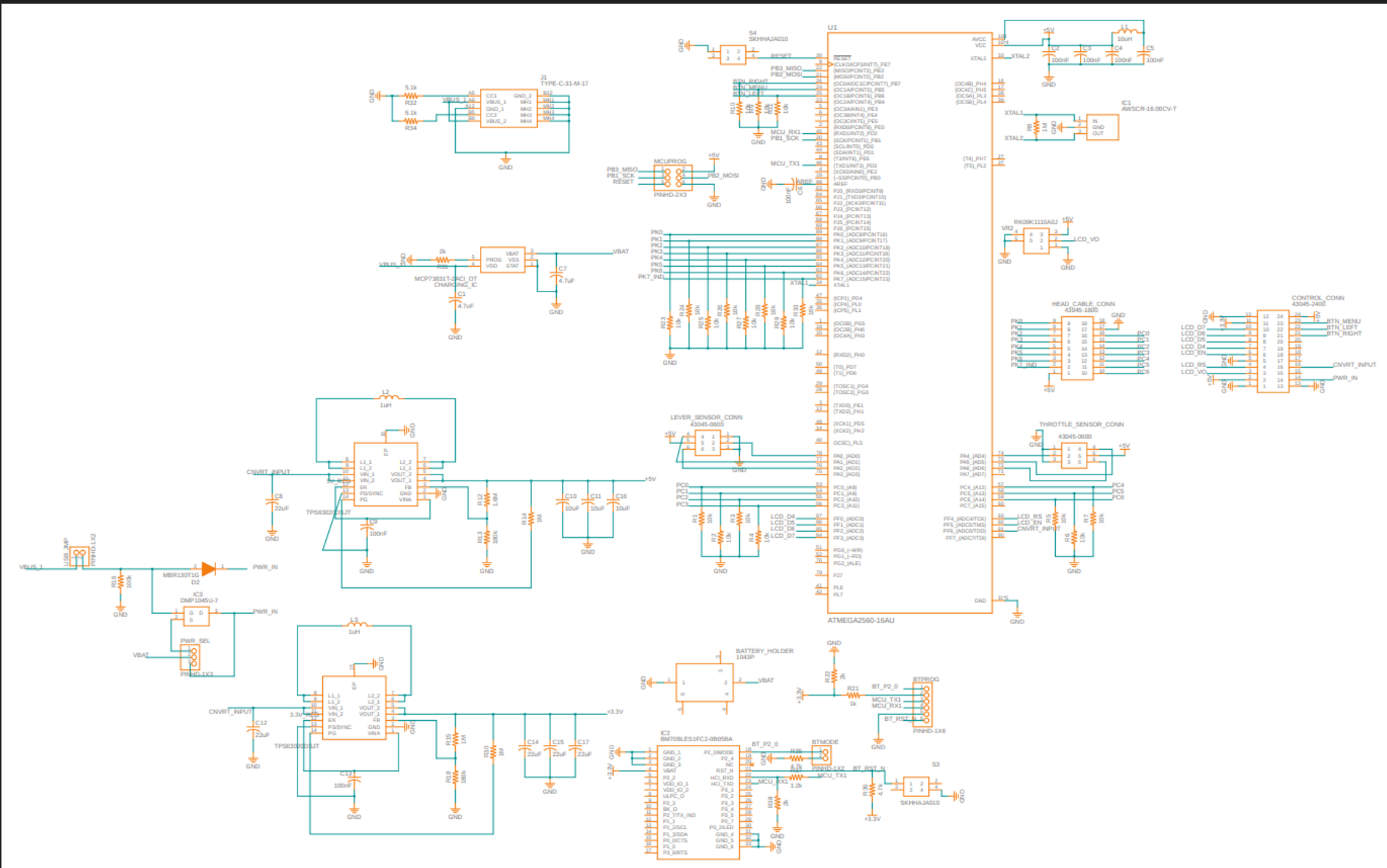

Joseph

Software Design



Mark

Software Tools

- Arduino IDE
 - Programmed in a modified version of C++
 - Provides useful libraries for embedded programming
 - Allows for programming during initial testing to easily transfer to final product
- USB-IDF HID Descriptor Tool
 - Streamlines the process of creating HID reports that adhere to HID standards
 - Report format generated via Descriptor Tool is then used when forming messages to BM70 Bluetooth module



High-Level Software Block Diagram

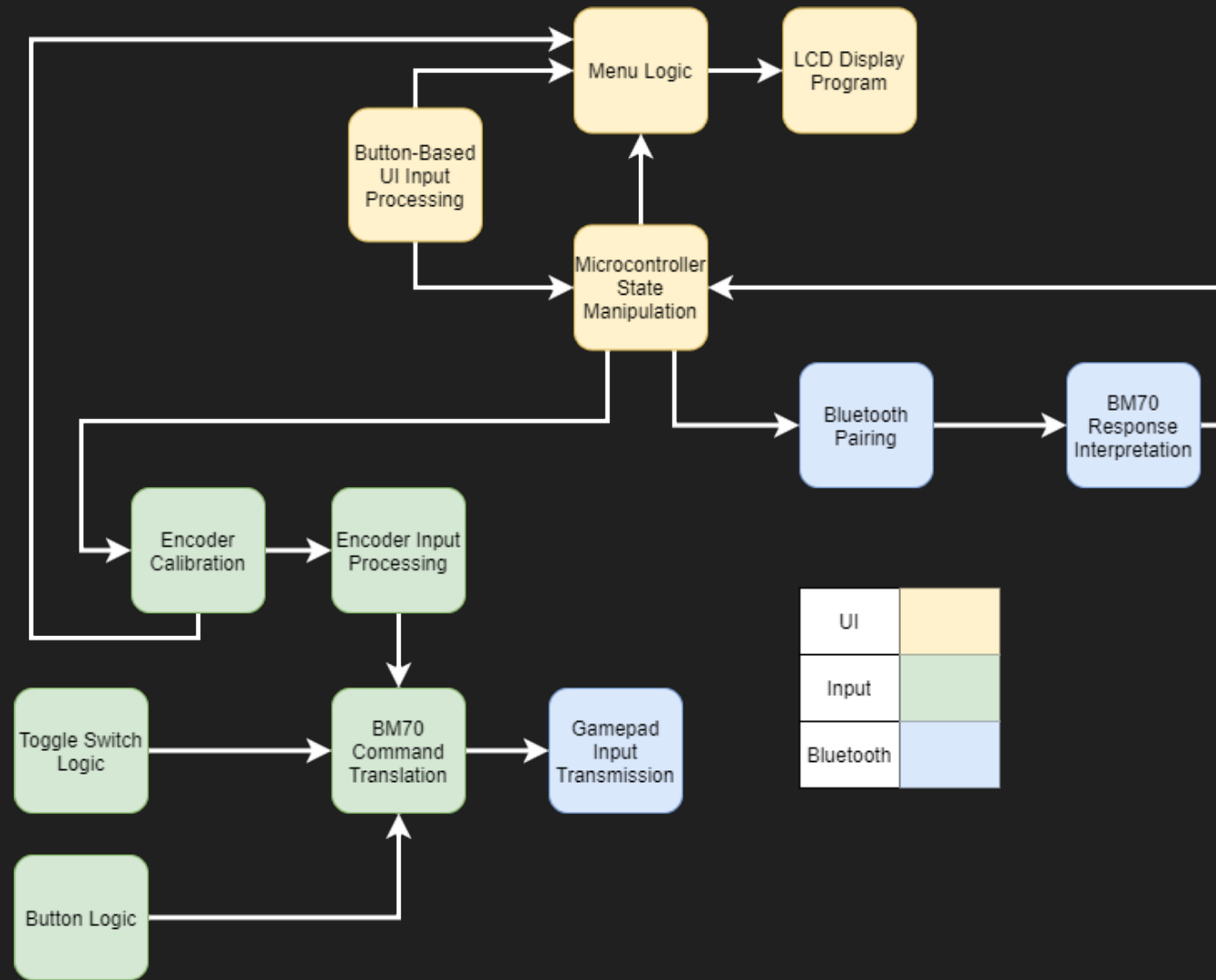

State-Based Menu Logic

- Software implementation on a high level implements logic that switches between various states
 - Encoder Calibration
 - Bluetooth Setup
 - Bluetooth Transmission/Normal Operation
- Movements between states initiated by user via buttons on collective base



Encoder Input and Calibration

- Absolute rotary encoders require specific software to take in and transmit their value
 - Data from encoder requested via specific clock signal manipulation
 - Angular position of encoder reported as value in range of 0 to 1023
 - Range of encoder encompasses full 360° range of motion, collective lever has limited range of motion
 - Calibration software implemented in calibration mode to allow user to set upper and lower bound of lever movement
 - Values taken in from the encoder from limited range of lever movement are then expanded into a range of 0-1023 to be sent over Bluetooth



Bluetooth Communication

- BM70 utilizes specific command/response format consisting of a string of bytes
 - Commands/responses will be sent/received byte-by-byte over UART to the BM70
 - Commands include start advertising Bluetooth connection, send GATT characteristic value
 - Responses include pairing complete and pairing failed and will be parsed by software to ensure proper connection to host computer

	HEAD		MID	DATA	CRC
	Start	Length	OP Code	Parameter	Checksum
Byte No	0	1 - 2	3	4 - xx	Length + 3
Size (Byte)	1	2	1	0	1
Value	0xAA	1	Command/ Event	Command/ Event parameter	Checksum
	SYNC WORD	Checksum to be calculated			
		TARGET LENGTH			

BM70 Command Format



Mark

Mechanical Design

Collective Assembly

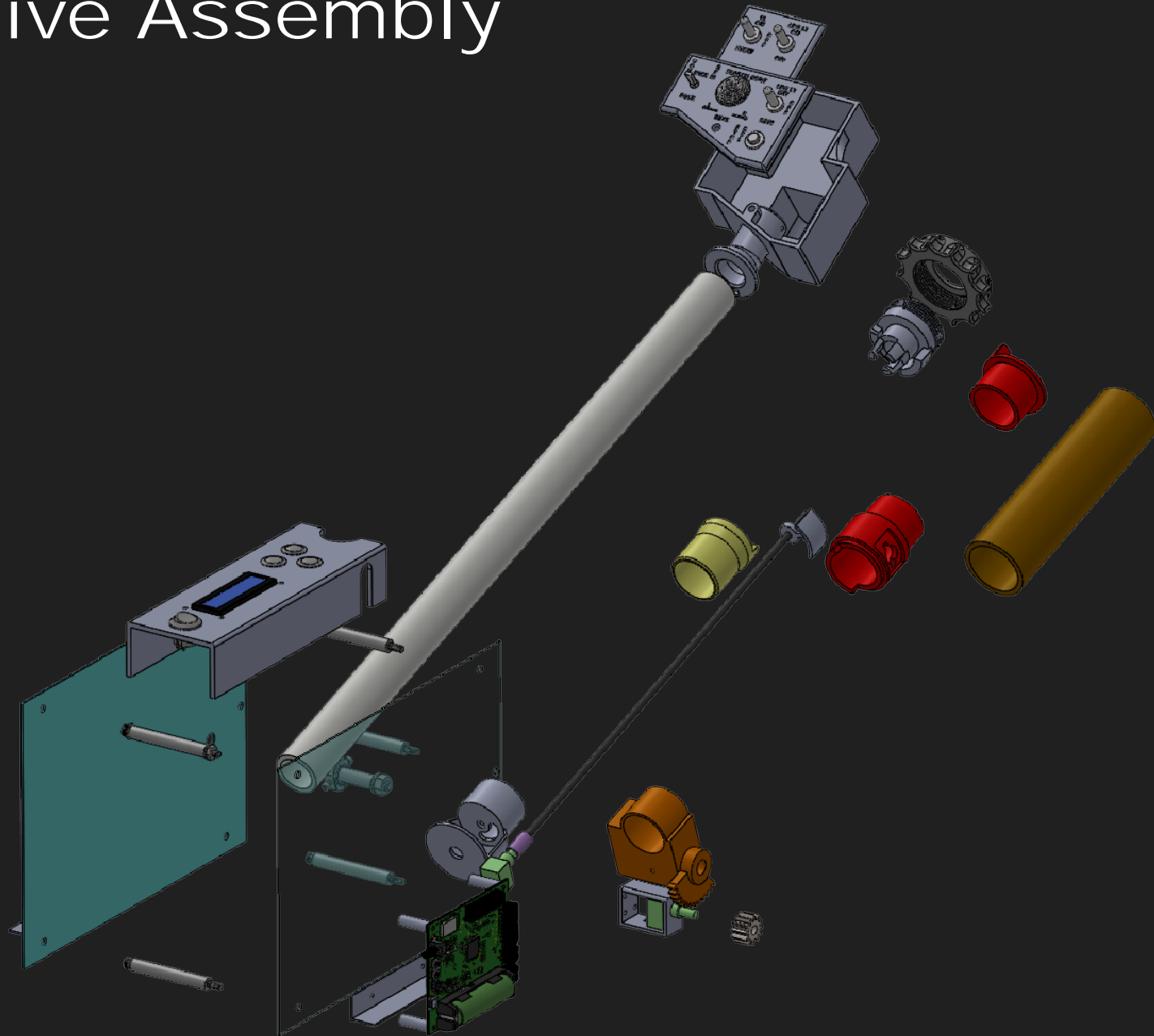

Collective Heads

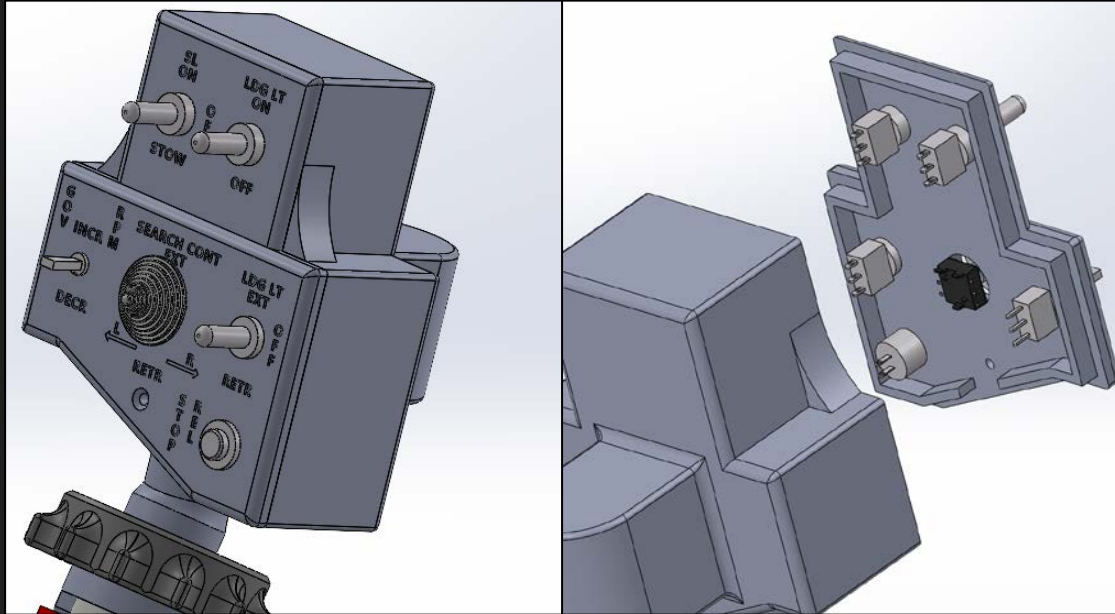

Huey collective head assembly and faceplate

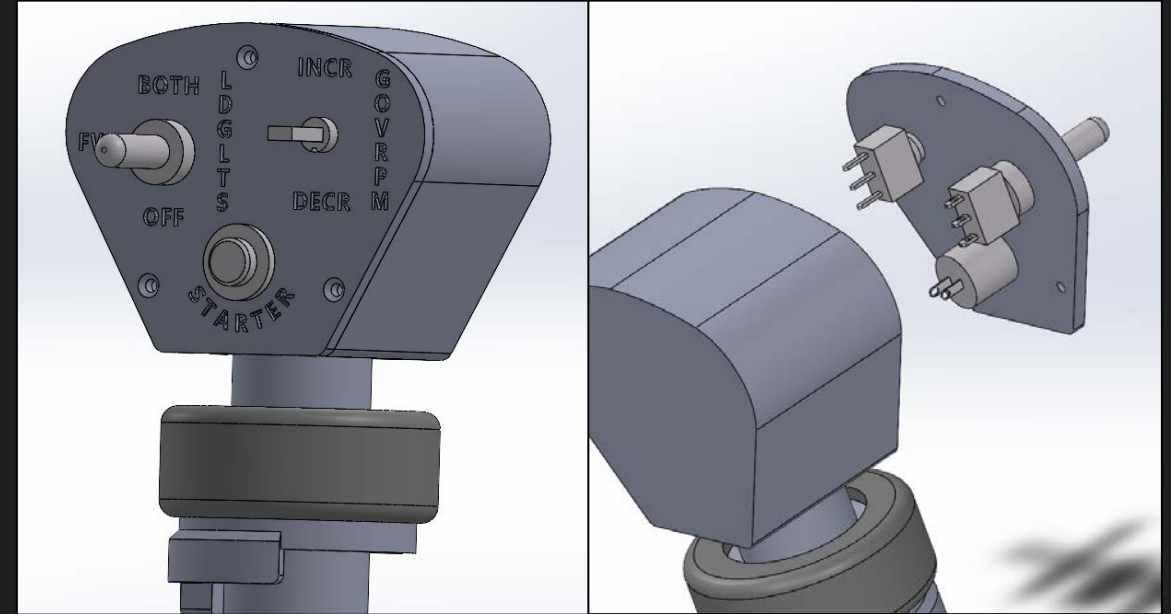

Bell 206 collective head assembly and faceplate

- Designed to replicate outside geometry of real collective heads based on reference images and technical manuals
 - Modifications made to aid in manufacturing and assembly

Collective Head Quick Detach

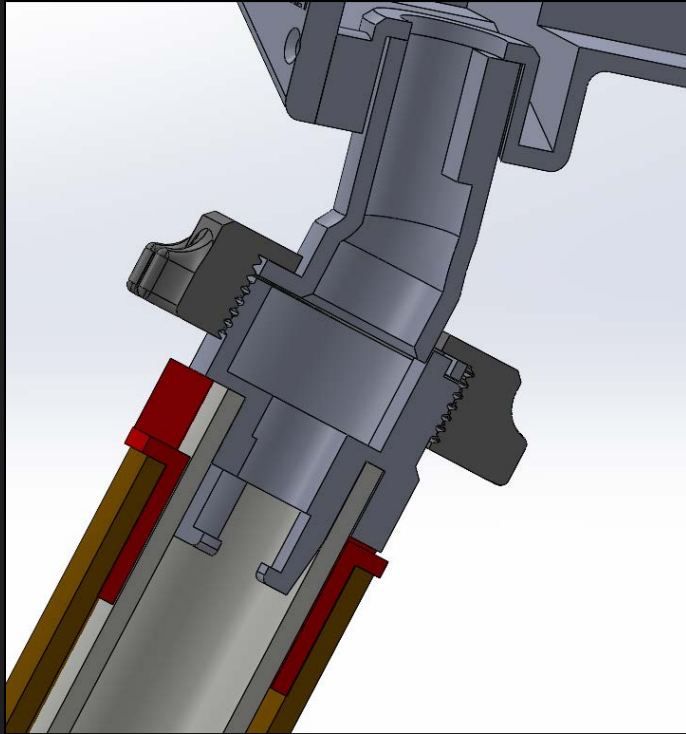

Huey head attachment method (cutaway)

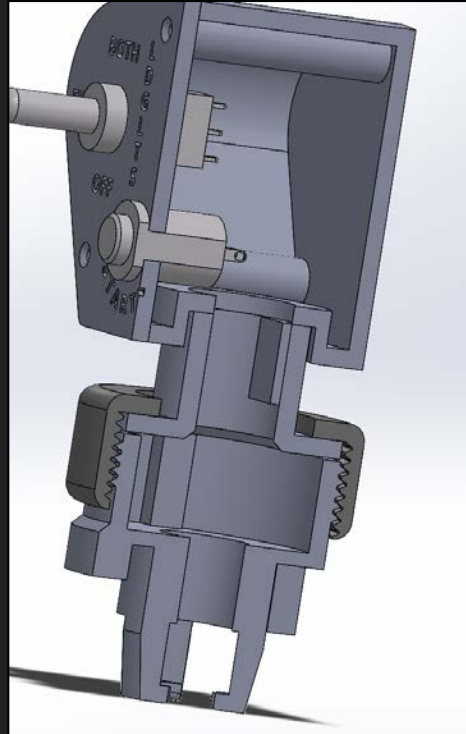

Bell 206 head attachment method (cutaway)

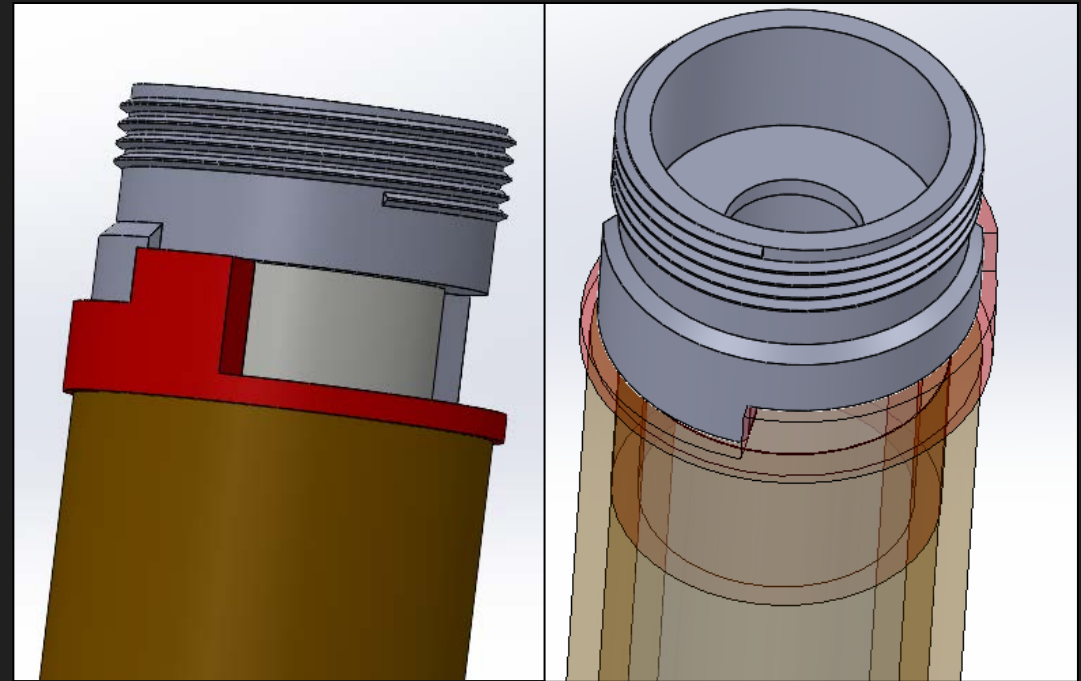

Collective lever endcap and 17-pin Molex interface

- Design specifications require the ability to interchange collective heads
 - Solution includes throttle stop integration, 17-pin Molex connector mounting, and toolless changing of heads

Collective Throttle

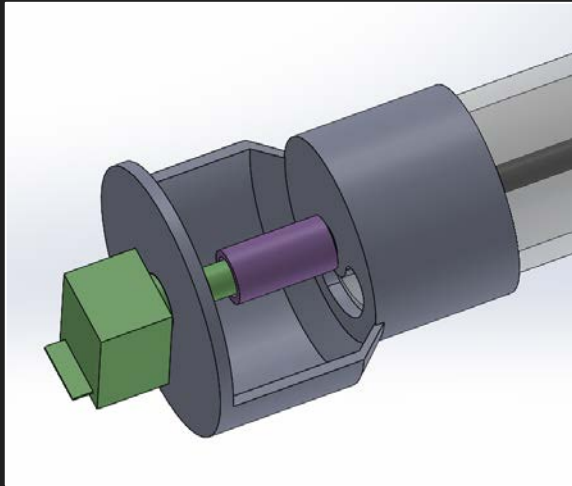

Throttle encoder housing

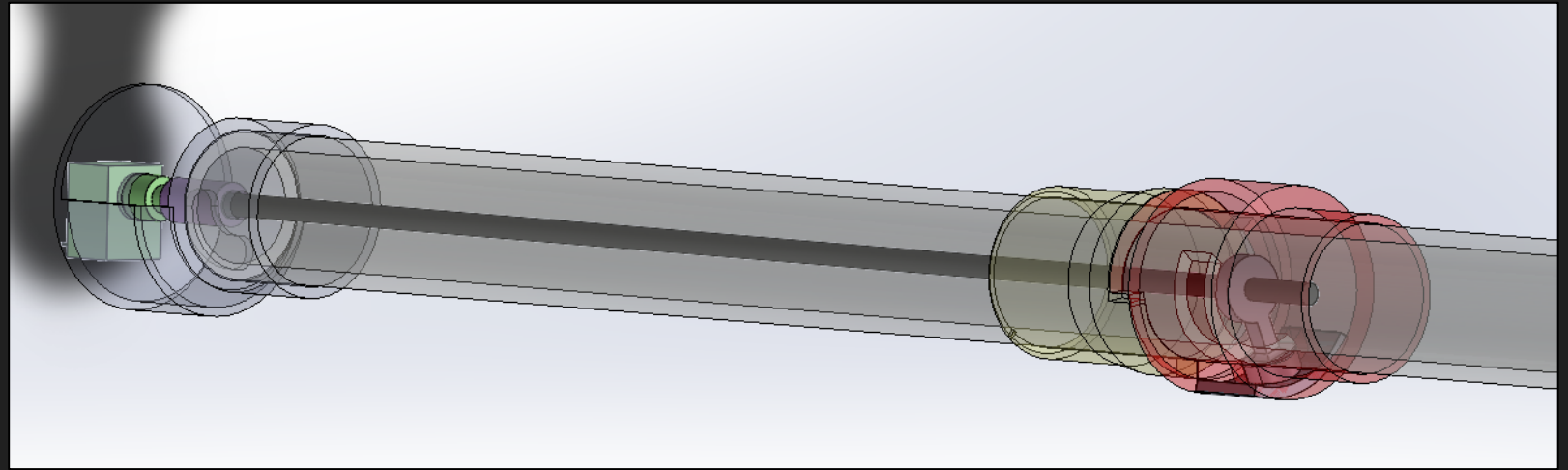

Throttle and connecting rod complete assembly

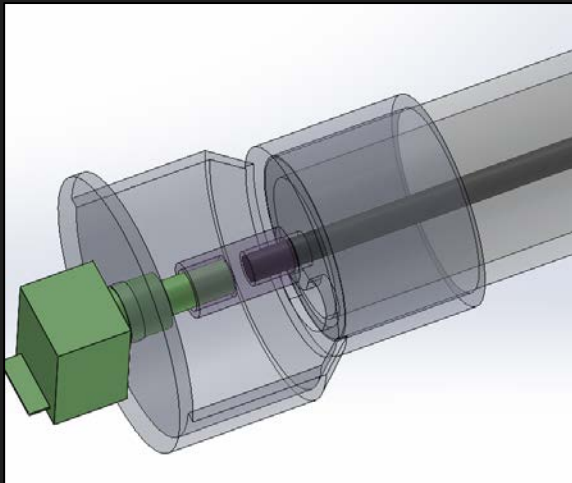

Connecting rod to encoder interface

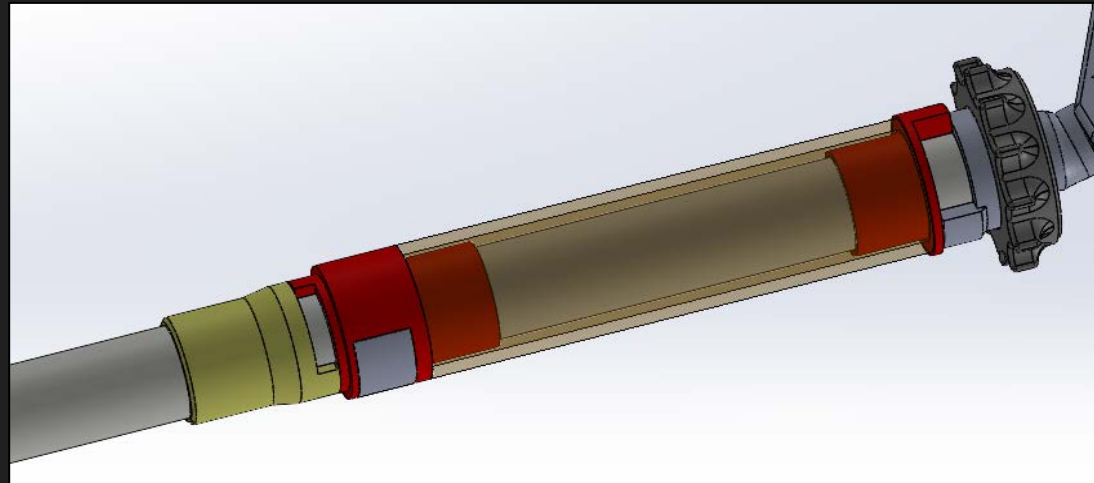

Throttle stops for rotational limiting

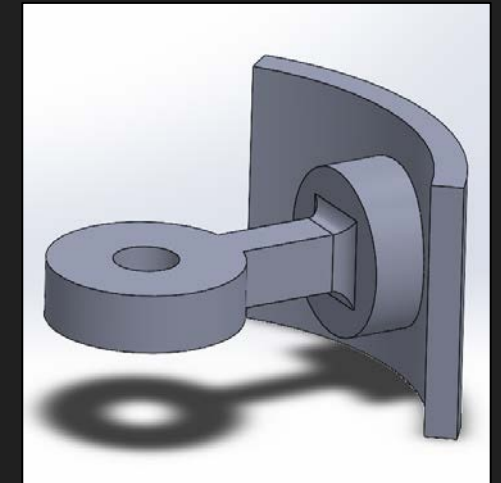

Throttle to connecting rod interface

Collective Lever

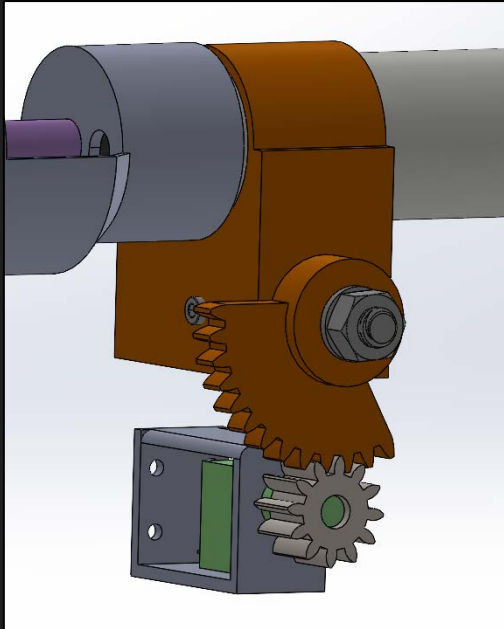

*Lever angle gear reduction
and encoder mount*

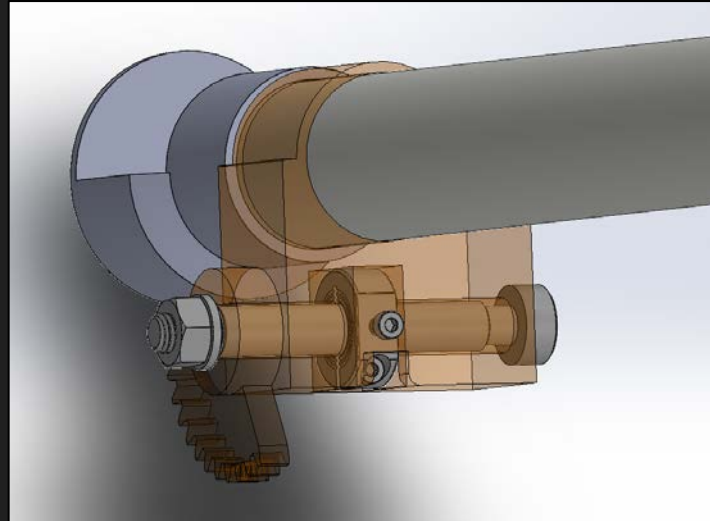

*Lever pivot and friction
adjustment mechanism*

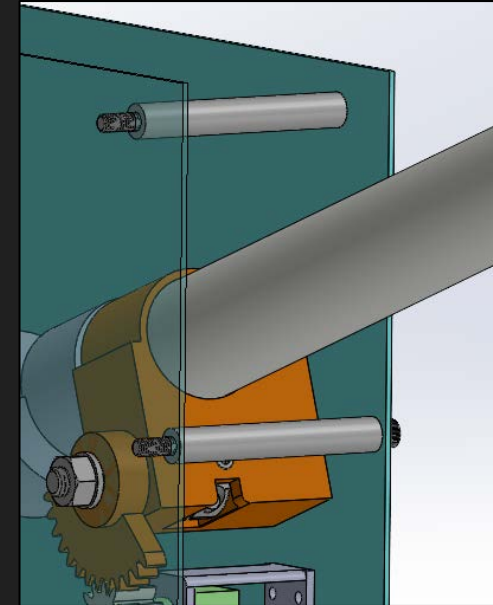

Lever angle travel stops

- Gear ratio: 3:1
 - Increases usable encoder steps from 128 to 384
- User can easily adjust the resistance of the collective lever

Base Unit

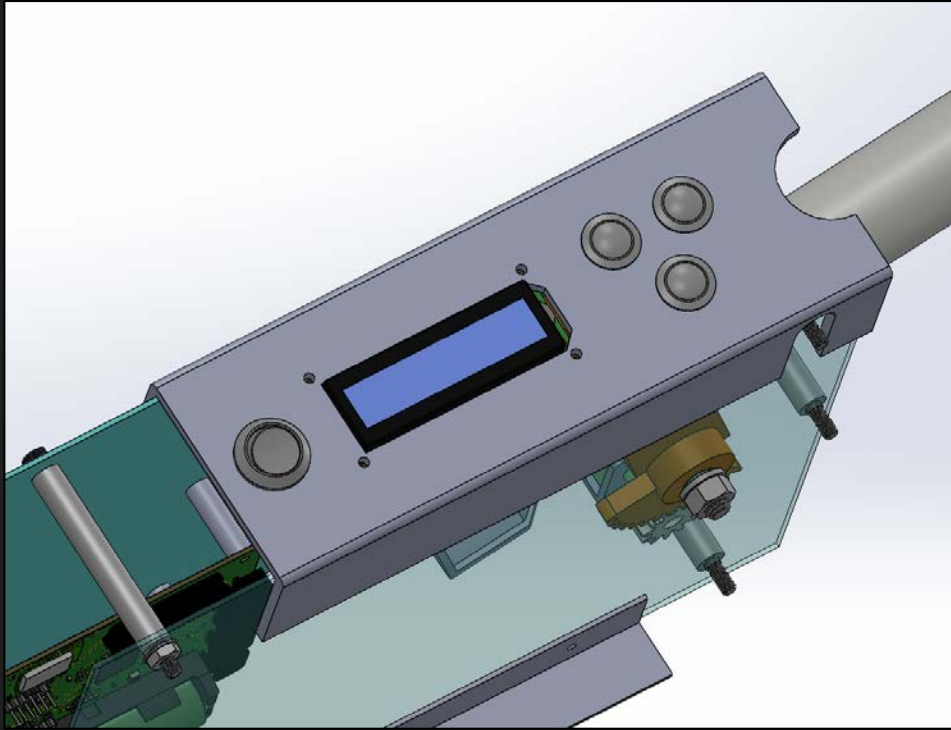

Base unit top panel

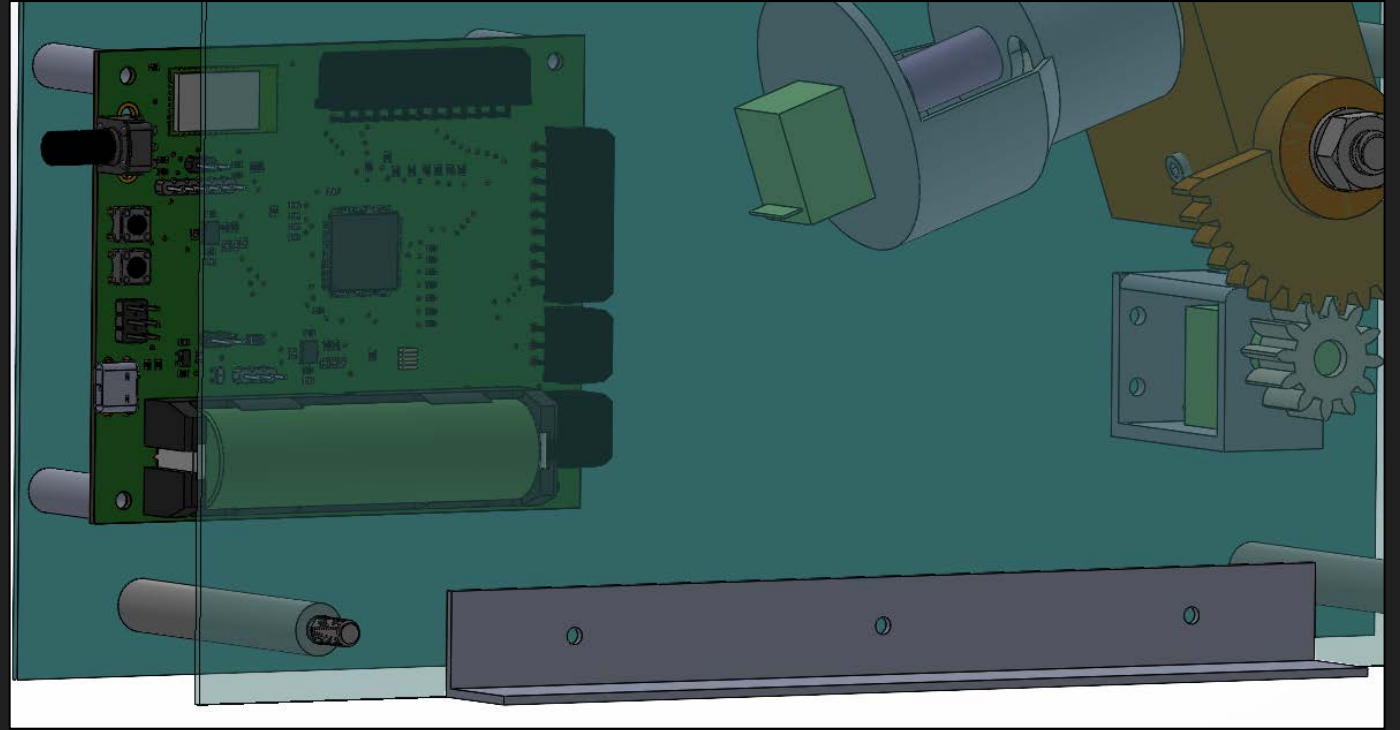

PCB positioning and unit mounting brackets

- Top panel controls allow for user to configure device
- PCB mounted to optimize the effective wireless connection range
- Mounting brackets designed for a variety of installation configurations

Administrative Content

Bill of Materials / Budget

Item Name	Part Number	Price Per Item	Quantity	Cost
18-8 Socket Screw	92196A283	\$ 1.01	5	\$ 5.05
Steel Hex Nut, Class 8, M8 x 1.25 mm Thread	90592A022	\$ 0.53	1	\$ 0.53
18-8 Stainless Steel Washer	98689A116	\$ 0.07	1	\$ 0.07
Stainless Steel Washer, Number 10 Screw Size	90107A011	\$ 0.04	5	\$ 0.20
Steel Hex Nut, 10-32 Thread Size	90480A195	\$ 0.02	5	\$ 0.10
10mm x 65mm M8x1.25 Shoulder Screw	92981A757	\$ 3.92	1	\$ 3.92
Shaft Collar, 10mm Shaft, 24 mm OD	7165N112	\$ 14.20	1	\$ 14.20
10 ft. Sch. 40 1 in. PVC Pipe	531194	\$ 5.28	1	\$ 5.28
10 ft. Sch. 40 1.5 in PVC Pipe	531111	\$ 7.96	1	\$ 7.96
eSun PLA PRO (PLA+) Filament 1 kg	781520911976	\$ 22.99	1	\$ 22.99
17 Position Male Circular Molex Connector	2021131730	\$ 11.24	2	\$ 22.48
17 Position Female Circular Molex Connector	2021131710	\$ 21.68	1	\$ 21.68
20-24AWG Tin Crimp Connector	430300001	\$ 0.05	54	\$ 2.81
18 Pos Male Molex Receptacle	430251800	\$ 0.99	1	\$ 0.99
24 Pos Male Molex Receptacle	430252400	\$ 1.45	1	\$ 1.45
6 Pos Male Molex Receptacle	430250600	\$ 0.46	2	\$ 0.92
EG2011-ND SPST Push Button	PS1024ABLK	\$ 1.27	1	\$ 1.27
EG2387-ND SPDT ON-OFF-ON Switch	100SP3T8B13M1QEH	\$ 4.04	3	\$ 12.12
EG2372-ND SPDT ON-ON Switch	100SP1T8B13M1QEH	\$ 3.58	1	\$ 3.58
EG2392-ND SPDT OFF-MOM Switch	100SP4T6B11M2QEH	\$ 4.54	2	\$ 9.08
EG1923-ND SPST Push Button	RP3502MABLK	\$ 2.72	1	\$ 2.72
1024 Position Absolute Magnetic Encoder	EMS22A50-B28-LS6	\$ 35.51	2	\$ 71.02
2.00 mm 6 Pos Female Plug Connector	5024390600	\$ 0.18	2	\$ 0.36
22-26AWG Tin Crimp Connector	5024380100	\$ 0.06	12	\$ 0.72
6x6x4.3mm Momentary Switch	Generic	\$ 0.05	4	\$ 0.18
2mmx8.5"x11" Adhesive-Backed Cork Sheets (2)	Generic	\$ 10.77	1	\$ 10.77
LCD1602 16x2 Display	ACM1602K-FL-YBW	\$ 4.76	1	\$ 4.76
Anti-Vandal OFF-MOM Push Button Switch	PV2S240NN	\$ 4.53	3	\$ 13.59
360 Brass Round Bar	BRR18	\$ 5.73	1	\$ 5.73
8"x11"x1/16" 3003-H14 Aluminum Sheet	S3063	\$ 15.26	2	\$ 30.52
3/4"x3/4"1/16" Aluminum Angle	A334116	\$ 4.25	2	\$ 8.50
SPST OFF-ON Rocker Switch	RR3130ABLKBLKES	\$ 2.35	1	\$ 2.35
Additional PCB Components	N/A	\$ 14.92	1	\$ 14.92
4000 mAh 18650 Li-Ion Battery	N/A	\$ 3.80	1	\$ 3.80
PCB Fabrication (Assembly, SMT Components)	N/A	\$ 23.00	1	\$ 23.00
Total Cost				\$329.62

This project is self-financed by the members of our team.

Project Progress

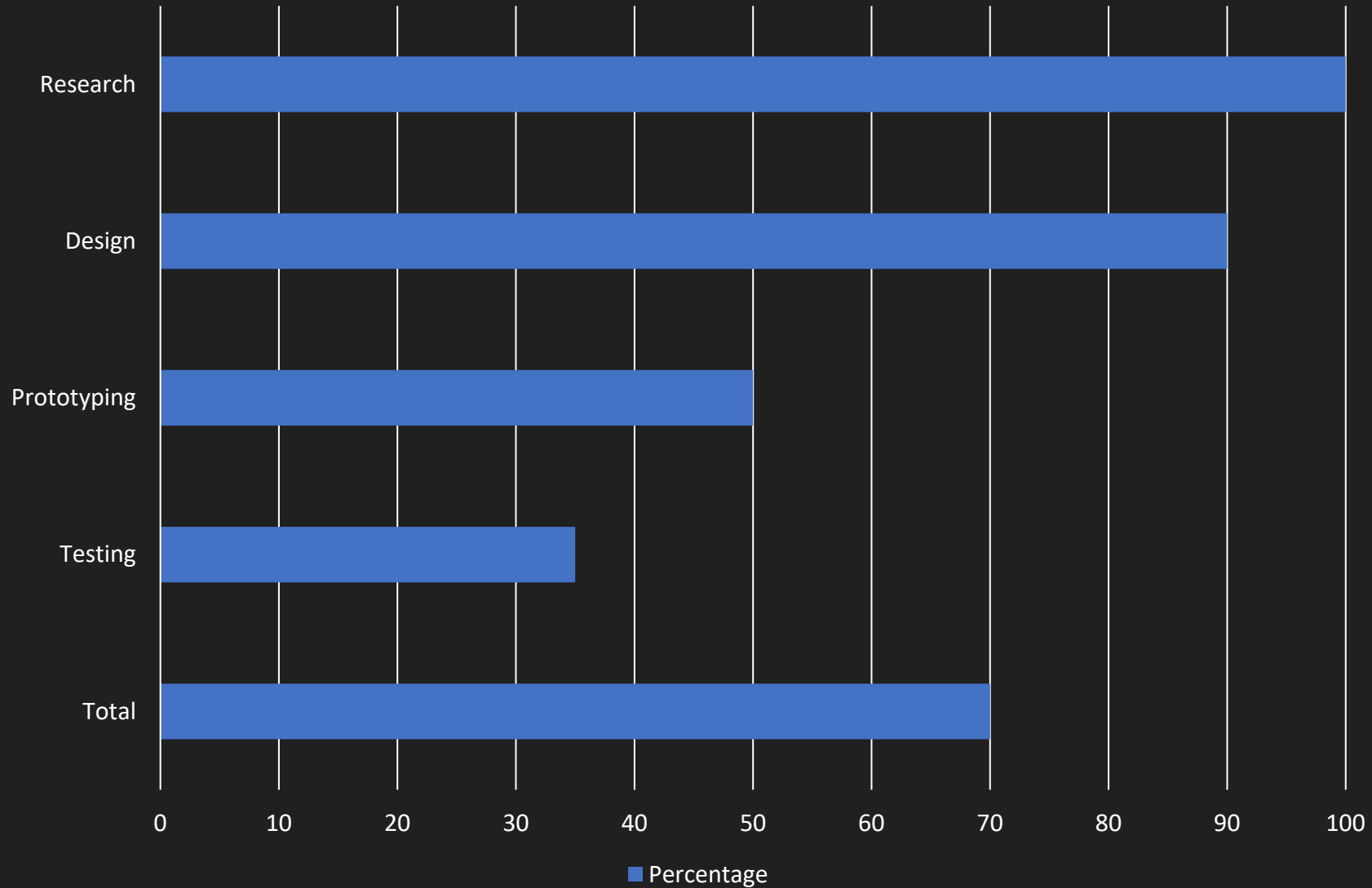

Next Steps

- 2nd Iteration of PCB is currently being manufactured
 - Assemble components not put on by manufacturer
 - Test PCB functionality
- Physical assembly of the collective lever and base
 - Almost all parts already acquired or 3D printed
- Transfer and update program from initial testing on development board to microcontroller on PCB
- Final product testing against requirement specifications