

Personal Wardrobe Assistant



Spring 2021

Group Number: 17

Efren CintronElectrical Engineering

Maximilian CarrollElectrical Engineering

O'Neal Thomas.....Computer Engineering

Juan Herrera.....Computer Engineering

Table of Contents

1.Executive Summary	9
2.Project Description	9
2.1 Project Overview	10
2.2 Objectives	10
2.3 Requirements/ Specifications	11
2.3.1 Demonstrable	12
2.4 Block Diagram	13
2.4.1 Diagram Description	14
2.5 Engineering Market house of Quality	14
3. Technology Research & Part selection	16
3.1 RFID System	16
3.1.2 History of RFID	16
3.1.3 RFID Basics	16
3.1.4 Comparison	19
3.1.5 RFID Selection	20
3.2 RFID Antenna	21
3.2.1 Size	21
3.2.2 Indoor or Outdoor	22
3.2.3 External or Integrated	22
3.2.4 RFID Energy Flow	23
3.2.5 Circular or Linear	24
3.2.4 Far Field or Near Field	25
3.2.7 High Gain or Low Gain	26
3.2.8 Wide or Narrow Beamwidth	27
3.2.9 Directional vs Omni-Directional	28
3.2.10 Overall design of our Antenna	29
3.2.7 RFID Reader	29
3.3.1 ID3-LA RFID Reader	29
3.3.2 ID-3LA Specs	30

3.3.3	Considerations of adding other external components	34
3.3.4	Designing Coils for ID-3LA	34
3.4	Wire	34
3.4.1	Copper Wire	34
3.4.2	AWG	35
3.5	Transponder	36
3.5.1	General Information	37
3.5.2	History of RFID	37
3.3.1	Passive vs Active RFID	39
3.6	Power Supply	42
3.6.1	AC Versus DC	42
3.6.2	Power supply basics	42
3.6.3	Batteries	46
3.6.4	Part Selection	47
3.6.5	stretch goals	
3.7	Interfacing with RFID reader (Wi-Fi) Power supply basics	54
3.7.1	History	54
3.7.2	Choosing Microcontroller	55
3.7.2.1	Choosing Microcontroller	55
3.7.2.2	Arduino	56
3.7.2.1	Raspberry Pi	57
3.7.2.1	MSP430	58
3.7.2.1	Ada Fruit	59
3.7.3	Interfacing with ID-3LA	60
3.7.4	Backup RFID Reader	61
3.7.5	Using AdaFruit	62
3.7.6	Power Management	63
3.7.7	USB to UART	65
3.7.8	Wi-Fi in LoT	66
3.7.9	ESP8266 Wi-Fi Module	67
3.7.10	Using Arduino IDE	68

- 3.7.11 Connecting ESP8266 69
- 3.7.12 Backup for AdaFruit 70
- 3.7.13 Connecting ESP8266 71
- 3.8. Web Application 72
 - 3.8.1 Stacks 72
 - 3.8.2 Databases 73
 - 3.8.2.1 SQL 73
 - 3.8.2.2 NOSQL 74
 - 3.8.2.3 Database Model 76
 - 3.8.3 Backend Framework 78
 - 3.8.3.1 Fastify 78
 - 3.8.3.2 Express 78
 - 3.8.4 Runtime Environment 79
 - 3.8.4.1 Elixir 80
 - 3.8.4.2 ASP.NET 80
 - 3.8.4.3 NodeJS 81
 - 3.8.5 Server 81
 - 3.8.5.1 Apache 82
 - 3.8.5.2 NGINX 82
 - 3.8.6 Client Side 84
 - 3.8.6.1 Vue 85
 - 3.8.6.2 React 85
 - 3.8.6.3 Angular 85
 - 3.8.7 CSS86
 - 3.8.7.1 Bootstrap 87
 - 3.8.8 Testing 87
 - 3.8.8.1 Postman 88
 - 3.8.8.2 Robo3t 89
 - 3.8.9 Hosting 90
 - 3.8.9.1 Database Hosting 90
 - 3.8.9.2 Web Hosting 91
- 4. Design93**
 - 4.1 Application 93
 - 4.1.1 Database Design 93
 - 4.1.2 Client-side UI 95
 - 4.2 Standards and Design Constraints 96
 - 4.2.1 Standards 96
 - 4.2.2 Antenna Standards 96

- 4.2.3 RFID Reader Standards 97
- 4.2.4 Microcontroller Standards 97
- 4.2.5 Voltage Supply Standards 97
- 4.2.6 Design Constraints 97
- 4.2.7 Antenna Design Constraints 97
- 4.2.8 RFID Reader Design Constraints 98
- 4.2.9 Microcontroller Constraints 98
- 4.2.10 Voltage Supply Constraints 98
- 4.2.11 Time Constraints 99
- 4.2.12 Experience Constraints 99
- 4.2.13 Resource Constraints 100

5. Personal Wardrobe Assistant100

- 5.1 Hardware Design 100
 - 5.1.1 Hardware Design Power100
 - 5.1.2 Hardware Design RFID Antenna103
- 5.2 Testing Microcontroller Design Power112
 - 5.2.1 Powering Microcontroller112
 - 5.2.2 Testing Wi-Fi Microcontroller113
 - 5.2.3 Testing UART114
 - 5.2.4 Testing Power & LCD 120
 - 5.2.5 Testing Power Supply 122
 - 5.2.5 Testing Antenna 124

6. PCB Final Design126

- 6.1 PCB Circuit 126
- 6.2 PCB Board 127

7. Administrative128

- 7.1 Milestones 128
- 7.2 Budget 129
- 7.3 Communication 130

Appendix134

List of Figures

- Figure 1: Block Diagram for Prototype13
- Figure 2: Block Diagram workload distribution 14
- Figure 3: House of Quality15
- Figure 4: Visual representation of RFID system 17
- Figure 5: RFID Antenna size comparison22
- Figure 6: RFID antenna cable integration24
- Figure 7: Linear Polarization vs Circular Polarization 25
- Figure 8: Near Field vs Far Field26
- Figure 9: Linear Polarized Antenna vs Circular Polarized Antenna 28
- Figure 10: Omni-Directional vs Directional antenna 29
- Figure 11: Photo of the ID-3LA reader30
- Figure 12: Pin out for ID-3LA 31
- Figure 13: Circuit Diagram for ID-3LA 33
- Figure 14: Copper wire to be purchase 35
- Figure 15: AWG cables/ wire sizes35
- Figure 16: RFID tag37
- Figure 17: Passive tag used in project 40
- Figure 18: Block diagram of a regulated Power system 43
- Figure 19: Smoothing capacitor and effects on current or voltage. 44
- Figure 20: Battery cell diagram46
- Figure 21: Voltage regulator L7805CV 48
- Figure 22: Battery pack 48
- Figure 23: Lithium-ion battery (probable power source) 49
- Figure 24: Voltage divider with formulas50
- Figure 25: Zener regulator51
- Figure 26: Pins on L7805CV regulator 52
- Figure 27: Step down regulator (provided by datasheet) 53
- Figure 28: TMS1802NC55
- Figure 29: Arduino56
- Figure 30: Raspberry Pi57
- Figure 31: MSP43058
- Figure 32: Adafruit Feather HUZAZH60
- Figure 33: ID-3LA Schematic (Copyright permission granted) 62
- Figure 34: EM18 Schematic63
- Figure 35: Adafruit feather HUZAZH 63
- Figure 36: Using rechargeable battery via feather 64
- Figure 37: AP2112K schematic65
- Figure 38: Example USB module DC-DC converter 66
- Figure 39: CP2104 Schematic66
- Figure 40: CP2104 Chip layout67

Figure 41: ESP8266 Schematic (Copyright permission pending)	68
Figure 42: ESP8266 chip	69
Figure 43: MSP430 layout	72
Figure 44: ESP-01 Graphic	72
Figure 45: 16x2 LCD screen	73
Figure 46: buttons	73
Figure 47: Multiple different databases based on the SQL and NoSQL Structure	75
Figure 48: Sample of a SQL Database	76
Figure 49: Sample Schema of a NoSQL database	77
Figure 50: Sample Schema of a NoSQL database	78
Figure 51: Database Model for the WebApp	78
Figure 52: Request per second of multiple frameworks	.80
Figure 53: ASP and Node benchmark comparisons	82
Figure 54: Server market share over 10 years.	83
Figure 55: Request per second for multiple cache solutions	85
Figure 56: Average Response time for multiple cache solutions	85
Figure 57: React vs Vue vs Angular	86
Figure 58: Popularity Vue vs React vs Angular	87
Figure 59: Sample Bootstrap 4	89
Figure 60: Sample Get Request on Postman	90
Figure 61: Robo3t Interface	91
Figure 62: Mocha Testing	92
Figure 63: Completed Database Model	95
Figure 64: JSON Package	96
Figure 65: Database inside Robo3t	97
Figure 66: Sample Data Input	98
Figure 67: tentative power circuit	103
Figure 68: output final power circuit	104
Figure 69: PCB power circuit	105
Figure 70: PVC with different size	106
Figure 71: PVC wired with enameled copper	108
Figure 72: Testing Antenna, ID-3LA Reader on RFID Qwiic kit connected with RFID Qwiic Reader	109
Figure 73: Output Waveform of the Antenna	110
Figure 74: microUSB pinout	114
Figure 76: Serial Output of Wi-Fi connect and POST request test	115
Figure 76: Voltage output of MSP430 power supply	116
Figure 77: Serial output of EM18 test	117
Figure 78: Physical test circuit for EM18	118
Figure 79: EM18 test circuit	118
Figure 80: Physical picture of the ID-12LA test circuit	119
Figure 81: ID-12LA circuit	120

- Figure 82: Serial Output of ID-12LA test 121
- Figure 83: LCD screen Powered ON 122
- Figure 84: Testing the voltage regulator 123
- Figure 85: Parallel Capacitance 124
- Figure 86: Output of regulator with capacitors 125
- Figure 87: tentative power supply PCB 125
- Figure 88: Voltage regulator connected to the ID-3LA Qwiic kit 127
- Figure 89: Schematic of PCB prototype 127
- Figure 90: Board design prototype PCB 127

List of Tables

Table 1: comparison RFID and barcode.....	20
Table 2: RFID antenna considerations	21
Table 3: Specs for our RFID antenna	23
Table 4: Device operational characteristics	30
Table 5: Pin description & output data formats	31
Table 6: Absolute Maximum ratings	32
Table 7: Standard wire gauge chart	36
Table 8: comparison tags	41
Table 9: comparison power supply	54
Table 10:SQL VS NoSQL	79
Table 11: Fastify & Express.....	80
Table 12: Comparison between Elixir & Nodejs & ASP	83
Table 13: NGINX VS APACHE	84
Table 14: Comparison between Vue & react & angular	88
Table 15: Heroku vs Google App Engine	94
Table 16: PVC inner diameter	106
Table 17: Antenna number of turns	107
Table 18: Results for Antennas without tuning up	111
Table 19: Results for Antennas with tune up	112
Table 20: Antenna testing results	126
Table 21: Overview of milestones for project	128
Table 22: Wardrobe assistant budget	130

1. Executive Summary

Wardrobes are part of everyday life. Most people will use one at one point throughout their day. No wardrobe is like the other, people have different likings when it comes to clothes. We much rather have more clothes than what we need. Leaving aside the primary reason for this project, people have too many clothes that they do not use. Leading to the problem of having too many articles of clothing simply sitting in their wardrobes. Most of the articles are collecting dust, instead with this project we want to realize which are the least worn clothes in their closet so they can either donate them or sell them.

The application aims to assist the user with wardrobe inventory tracking, informing the user of their favorite trends and styles. This will assist users into smarter, more informed decisions of their style when they are ready to purchase new clothes. Additionally, the application will also demonstrate and display the trends that the user does not particularly like. Leading to more efficient and cost-effective wardrobes with less clutter and more space efficiency.

The system will be as small, and portable as possible for convenience since you really should not be changing wardrobes all that often. The user will need to attach one of the RFID tags to any article of clothing. After they will update a form on the application to add the information pertaining to the RFID tag. This is how all articles of clothing will be tracked and managed, later the data we gather from the user we will provide statistics to help improve the user efficiency.

Should time permit, we will implement an outfit maker utilizing the pictures and information from the data in the database. Working with many cloth donation locations we can tell the user when the most optimal time to donate their clothes would be. Additionally, waterproofing and heat proofing the RFID tags in a way where they would be able to be washer and dryer safe would be a huge improvement on the system. Allowing users to worry less about the RFID tags and be able to utilize the system without much thought.

2. Project Description

Basic overview, motivations and goals this project is going to have. Also describing the planning stages and basic work distribution.

2.1 Project Overview

In the modern world the idea of automation has spread far and wide to virtually every aspect of a person's life. The process of Automation has been applied to many different ideas to great effect, Like Henry Ford with the car manufacturing process or the McDonalds brothers with fast food. Some people claim it to be an inevitability that machines will soon do every task that the average person finds too trivial. What about the most basic of human activities though? Simple menial tasks that waste a person's time, that could be used more productively. There are many individuals, across the planet, that find organization to be mandatory. It obviously allows them to be more efficient and save time. Like everything else a person does it is prone to human error or interruptions from outside sources. The idea of Automated organization is very simple in concept but what would be the best way to test this theory.

There are hundreds of people who want to keep neat and orderly. For demonstration purposes, what better way to test this idea than on clothing. Keeping track of clothes becomes more cumbersome the more one thinks about it. A person has lost their favorite shirt even though they are certain it was in their closet, but it cannot be found. Ensuring that people remember to wash the clothes they need for a specific situation or realizing that this brand of attire has not been worn in months. So why not donate it or dispose of it? This project isn't limited to clothes. Once completed it could be used in the kitchen to organize ingredients or by a student who has too many notebooks/ binders.

The inventory system will consist of three major components that will assist the user in organizing their wardrobe. A radio frequency identification tag (RFID tag), a RFID scanner, and a user-friendly application. The tags will be attached to the hangers which will be carrying unique pieces of clothing that the user wants to keep track of. The RFID tags will serve as the input for the system. For testing and demonstration, the system will be limited to an input of three to five items. These tags will be detected by the scanner when entering and leaving the inventory.

The scanning device will be wall mounted and have a minimum range of twelve inches. It will consist of three major components. The sensor, a microcontroller and a PCB that connects the two. The sensor's role is to pick up the specific signal from the RFID tag then send it to the microcontroller. The PCB board will ensure that this signal is properly transmitted and received. Once it reaches the microcontroller the data will be transmitted to a database via Wi-Fi.

When the data has reached its destination, a web application will allow the user to interact with the database and submit information on the unique article of clothing. Upon removal of an item from the inventory the user will scan the RFID tag corresponding to the article of clothing. This will trigger the database to check if the item is present. If it is in the inventory, then it will remove it from the database.

The wardrobe inventory system was designed to save the users time and give them peace of mind when dealing with their clothing. By implementing this system the user will have a clear oversight of what articles of clothing are inside of their inventory. By keeping track of items in their wardrobe the database will be able to display statistical analysis of what items the user wears frequently. This system achieves the goal of automation with regards to the process of organization.

2.2 Objectives

1. To help people with organization and time management.
2. Ensure that people don't waste space in their closet or have superfluous pieces of clothing.
3. To challenge our current abilities as student engineers.
4. Utilize the knowledge we have learned over our combined years of undergraduate study.
5. Learn more about radio frequency signals / Signal processing.
6. Learn PCB design and application.
7. Learn how to develop and deploy an enterprise software application.
8. Designing a project that can be utilized by the average person.
9. Learn how to work within a team.
10. Simulate a real life working environment.
11. Add this experience to our career resumes.
12. Demonstrating that automation can be applied to many different concepts and ideas.
13. Inspire future senior design groups.
14. Completing this project and finishing our undergraduate degrees.

2.3 Requirements / Specifications

- RFID tags
 1. The RFID tags will be mounted onto the clothing hangers.
- Passive RFID Scanner

1. Passive low frequency scanner range of at least 12 inches
 2. Feeds information to the microcontroller. (Via direct UART pins)
 3. Will be mounted to a wall outside the closet.
- PCB board that connects the scanner to the microcontroller
 - Microcontroller
 1. Powered by a battery pack of 8 AA batteries. (Approximately 12 volts)
 2. In low power mode (LPM) until the RFID tag is detected and will return to LPM after 60 second.
 3. Connects to WiFi
 4. Sends POST requests
 5. LCD screen for configuration
 - Implement a MERN stack (MongoDB, Express, React, NodeJS)
 1. MongoDB - document database
 2. Express(.js) - Node.js web framework
 3. React(.js) - a client-side JavaScript framework
 4. Node(.js) - the premier JavaScript web server
 - Implement an API that will handle the interaction between the client and the server
 1. Log in
 - a. Register/ Log in
 - b. Recovery (Retrieve Username/ Update password)
 2. Primary Features
 - a. Create, Read, Update, Delete items from database
 - b. Statistical analysis on user interaction
 - i. Frequently used clothing chart
 - ii. Favorite colors chart
 3. Secondary Features
 - a. Support for Outfit Maker
 - i. Use pictures to create virtual outfits
 - b. Alerts
 - i. Receive alerts about recommend clothing to wear due to weather
 - c. Quick scan queue operation

2.3.1 Demonstratable

1. Scanning of the RFID tags

- a. Tags will be scanned, and necessary information will be presented.
- 2. PCB board
 - a. The RFID reader,
 - b. Power supply and
 - c. Antenna
- 3. Primary Features of the WebApp
 - a. We will demonstrate a walkthrough of the application.

2.4 Block Diagram

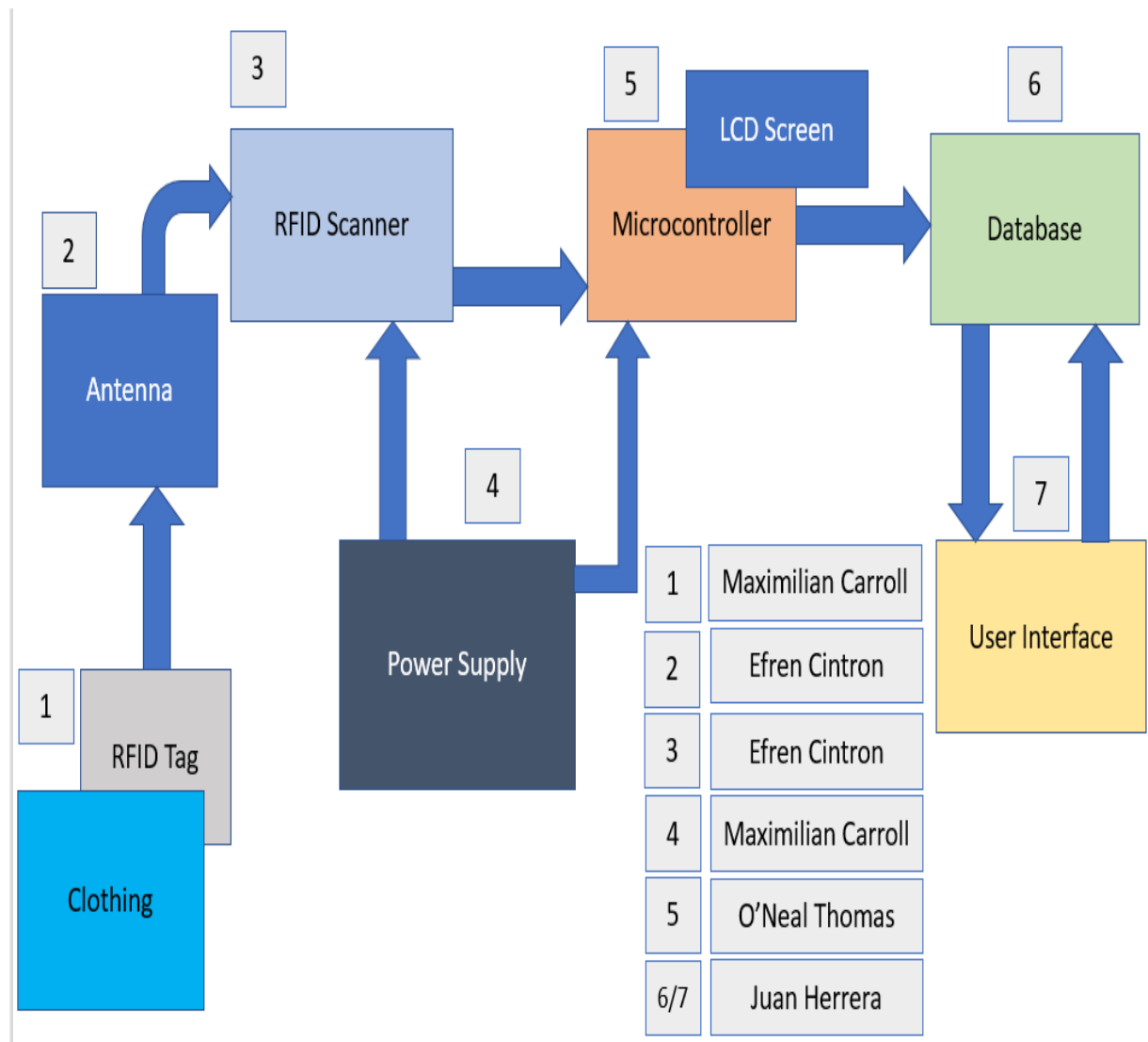

Figure 1: Block Diagram of Prototype

2.4.1 Diagram Description

4. RFID tag, Serves as input to the system.
5. Antenna will receive data from RFID tag and send it to RFID reader.
6. RFID Scanner/Reader processes the tag and sends the information to the Microcontroller.
7. Power supply will send power to the RFID reader & microcontroller.
8. Through Wi-Fi the microcontroller will send the information to the database POST request.
9. Wardrobe inventory is sent to the User from the database upon request.
10. Users will input new articles of clothing as needed into the database for inventory.

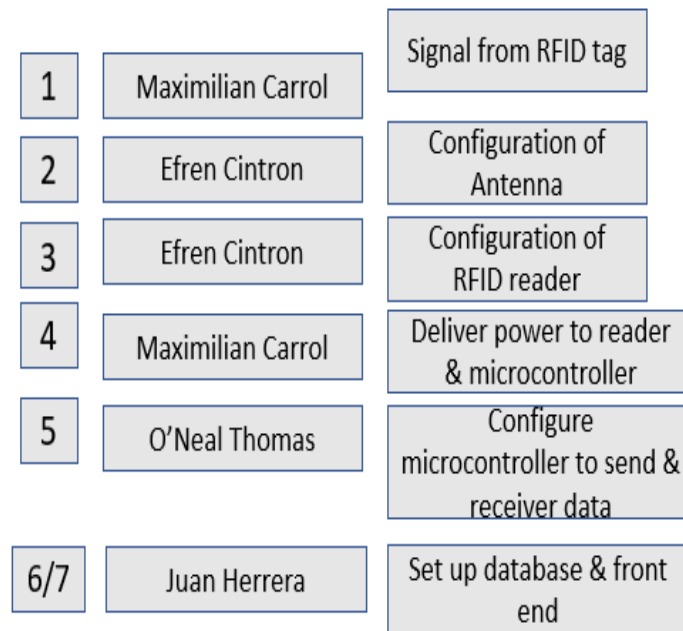

Figure 2: Block Diagram workload distribution

2.5 The Engineering-Marketing House of Quality

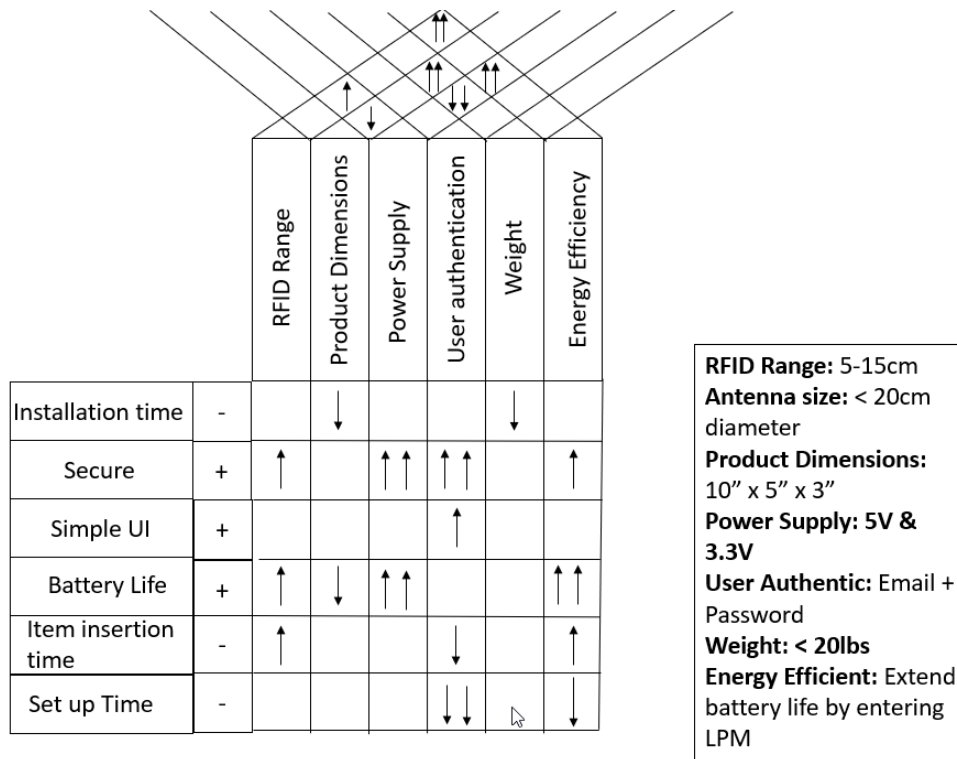

Figure 3: House of quality

Impacts and correlation

↑ Positive correlation

↓ Negative correlation

+ Positive impact

- Negative impact

No symbol: No correlation

- **Product Dimensions:** The overall size of the final product.
- **Range:** The effective range at which the scanner can effectively read the RFID tag on the desired article of clothing.
- **Cost:** The total cost of everything and how it affects the quality of the components used.
- **User Authentication:** Each user will gain access to their respective profiles via email and password
- **Power Supply:** The power supply must power the microcontroller and the RFID reader
- **Energy Efficient:** Utilizing low power mode on microcontroller to achieve extended periods of low power consumption.
- **Weight:** The overall weight of the final product

3. Technology Research & Parts Selection

3.1 RFID System

Basic overview of RFID system, parts history, and comparison to other auto identification system.

3.1.1 History of RFID

Radio frequency identification (RFID) can trace its origins to the Second World War with the invention of the radar. The Germans discovered that if they rolled their planes, it would alter the radio signal captured by a radar system. This is the earliest example of a passive RFID system. During World War Two both the axis and the allies continued to innovate on these technologies to gain an advantage over each other. Watson-Watt was responsible for heading the project that would become the first active identify friend or foe (IFF) system. The first step of the idea was for the British to equip every single one of their planes with a transmitter. Once the planes received a signal from a friendly radar station, the transmitter would begin broadcasting a signal back to the radar in order to identify it as friendly.

During the early stages of the Cold War both NATO and the Warsaw pact invested heavily into this technology, which caused it to expand rapidly. The continuous advancement of radar and RF communication systems, from scientists across the world, greatly benefited the process of developing an RFID system. The associated technologies were continuously innovated and improved until it was affordable for Businesses to commercialize them and sell them to the public. This has allowed RFID systems to integrate into many applications that benefit everyone in society.

3.1.2 RFID basics

There are three major components that an RFID system consists of: a scanning antenna, an RFID tag and a reader that decodes the interprets the information present on the data tag. The process for an RFID system starts with the tag. The tag stores all the necessary information to identify the product. Once the tag comes within scanning range of an antenna it causes electromagnetic energy to trigger the tag and send the information to the antenna in the form of radio waves. Once the radio waves have been identified by the antenna it sends

them to the reader which is responsible for decoding the information and processing it into digital information.

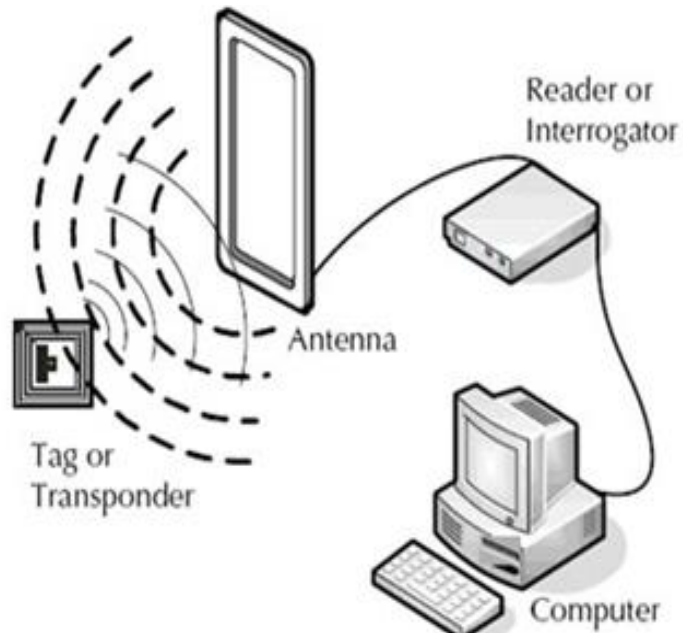

Figure 4: visual representation of RFID system

An RFID system in the modern age is typically used to communicate information wirelessly over a short distance. Even though the process for an RFID system is relatively simple to explain, there are many different applications and varieties of this kind of system. Despite this large variety of applications in RFID systems there are certain specifications that are more common than others. Most work done with RFID is done in two lower-frequency bands: 13.56Mhz and 125KHz. These specific frequencies are used in virtually every country when designing RFID systems.

RFID systems are a subcategory of Automatic Identification and Data capture (AIDC) technologies. As the name implies the focus of this technology is used to collect information from a specific object without manually entering the data information. There are numerous applications for these kinds of systems varying from distribution, manufacturing and even transportation. AIDC applications vary from identification and validation, tracking and interfaces to data systems. The various forms of AIDC systems were considered for the project of automatic inventory management.

The first major technology considered, and the one chosen, was an RFID system. There are many advantages to an RFID system. One major reason it was chosen is because this technology can scan multiple items simultaneously. Other optical scanners can only process one item at a time, but a RFID system does not suffer from this limitation. The second major advantage this system offers is that it does not require the tags to be in the line of sight. RFID systems do not have requirements for line of sight when being scanned and then processed. These two specifications were the most important for choosing the type of system because one of the principal goals of the project was to create a simple product. The user should not have to worry about the technology associated with the system. When the articles of clothing are taken from the closet or drawer there should be no limitations on the amount taken or unnecessary steps added like scanning the item in question.

There were some additional examples that weren't deemed essential but guaranteed the utilization of an RFID system in this project. Cost being one of them. In recent years the price associated with purchasing RFID tags has gone down substantially. Budget constraints are a major limitation for any project, but affordability was not an issue when choosing to work with an RFID system. One final positive aspect of working with this technology is that RFID systems have read and write capabilities. Certain identification systems, once they have been assigned a value, cannot be altered. In an RFID system certain tags can be altered as many times as the user wishes. Ideally this should encourage people to reuse the tags once they decide to dispose of or give away a certain article of clothing.

There are certain limitations associated with RFID systems though that will interfere with the end goal of completing the project. Disruption issues are a major concern in the design phase. RFID systems have quite a precise frequency on the electromagnetic spectrum and they are very sensitive to being jammed at these specifications. Even Wi-Fi can negatively impact the performance of the system. Collision issues when reading tags can also cause major problems for the system. Despite being able to read multiple objects simultaneously signals can still overlap when multiple tags are processed at the same time, but this concern is diminishing because of technological improvements with anti-collision protocols. These will mostly likely be the two largest issues in design and application that will hinder the goal from being as User friendly and simple as possible.

Other limitations include the tag being read from too long of a distance and without permission. The system being worked on is very small in application and is limited to at least a closet and at most the area outside of a closet. The range of the electromagnetic spectrum needs to be small enough where it can easily read the tag and process the information. The current goal is at least 10 cm. If the tags are within range of the antenna while in the closet the system will become confused and will always be reading them, which would destroy the entire goal of the project.

3.1.3 Comparison

Barcodes were another type of AIDC technology considered for the project. Even though they are quite like RFID systems, there are major differences between the two. A barcode is a visual representation of data in the form of numbers, text, or lines. There are regular barcodes which simply consist of thin lines arranged in a certain pattern that only follows one axis of dimension. The second kind of barcode is known as a 2D barcode, which stores information both horizontally and vertically. This picture contains details about the item in question and once scanned it can be accessed by a database. Barcodes can be found virtually any way from Identification cards to retail store items.

A two-dimensional barcode has the capability of storing 7089 characters while a traditional one-dimension bar code can only store 20 characters. This greater capacity for the two-dimensional bar codes allows the designer to even insert links to websites and other high data information. Barcode readers consist of a laser beam that is sensitive to the reflections from the line and space thickness variations. This is similar to an RFID system where the antenna picks up the information from the tag which is then digitally processed to the database. In the modern day it is even possible to scan a barcode with devices such as printers or even smart phones.

In choosing a system there are many advantages a barcode system has over an RFID system. Barcodes are much smaller and lighter than RFID tags. They are also significantly cheaper than RFID tags because they are directly printed onto the plastic or paper material. In a direct comparison of accuracy Barcodes are just as accurate as an RFID system, sometimes even more. They are a very established technology with many different resources available for people to do research and implement.

There are several disadvantages to barcodes though that make it less desirable than a RFID system for this specific project. Barcodes need a direct line of sight to work properly. This cannot be altered because the data for a barcode needs to be directly scanned by the laser otherwise it will not work properly. It is much more inconvenient for the user because they need to be scanned individually, and the processing of information takes longer compared to an RFID system. It is easier to damage a barcode than an RFID. General wear from the environment or it is exposed to the sun the pattern could begin to fade or become sun-bleached. Finally, a barcode won't work if there is any damage that impedes the bars that store the information. Once the tag is damaged it needs to be replaced with an exact copy because once a value has been assigned it cannot be altered in any way. If it is, the barcode data system will not recognize it as the original product but as a whole new one.

3.1.4 RFID selection

After discussing the advantages and disadvantages associated with each specific type of technology there were six criteria that were considered important in making a final decision for the project. Accuracy, speed, cost, ease of use, reusability, and stability. Accuracy for both RFID and barcodes is very similar so neither had a clear advantage in this case. RFID systems are able to process information quicker than a barcode system, and a goal for this project is to be quick and efficient. Barcodes are cheaper than RFID tags to produce but RFID tags are not significantly more expensive to implement. Ease of use refers to what the user has to do in order to process the information properly. A RFID system only needs to be within range of the antenna and then it is processed. A barcode requires direct line of sight and can easily be distorted if the tag is not clearly readable. Stability refers to how the system will try to work if any issues appear. Once a barcode is damaged or cannot be read clearly it won't work. RFID tags will work if the two components of the tag system are intact. Alterations refers to adding a new article of clothing or changing tags. It is significantly easier to alter an RFID tag because they have read/write capabilities, while a barcode cannot be altered.

Table 1: comparison RFID and barcode

RFID	Barcode
<ul style="list-style-type: none"> · Can read from a greater distance and depending on the tag are more accurate · Able to scan multiple tags simultaneously · Collision errors are common when scanning more than one tag at a time · Are able to store large amounts of information · More expensive and complex than barcodes. · Easily jammed by things like wifi or when there is a similar frequency being transmitted 	<ul style="list-style-type: none"> · Smaller and lighter than RFID tags · Less expensive than RFID tags · Almost equal in performance when it comes to accuracy · Not able to store as much information · Cannot be replaced once once a value has been assigned it is permanent and cannot be rewritten.

3.2 RFID Antenna

One of the most important elements of our Senior Design project is the RFID Antenna. This Antenna has two main functions: (1) Transmit power to the RFID Tags to activate them, and (2) receive the data from the RFID tags. In order to design an RFID Antenna, we need to consider some parameters based on

what we need. These selected parameters are going to make the RFID antenna works based on the specifications we are considering having.

Table 2: RFID Antenna Considerations

Small vs Large
Indoor vs Outdoor
Circular vs Linear
High Gain vs Low Gain
Narrow Bandwidth vs Wide Bandwidth
Directional vs Omni-Directional

3.2.1 Size

The Antenna size would determine the range from how far the RFID can be read. In other words, the bigger the antenna, the longer the range, the smaller the antenna, the less read range. For our design purposes, we don't need to have such a big antenna. Since we are using Low-frequency RFID tags, the read range is around 5 – 10cm away. With the antenna design, the size should not be that big to approach that distance that the antenna receives the RFID signal to read the tag information. So far, a smaller antenna is a must to keep the overall design neither big nor bulky, but just enough to fulfill those parameters. Since our Wardrobe Management System doesn't require a long-read range, we will keep it as small as possible.

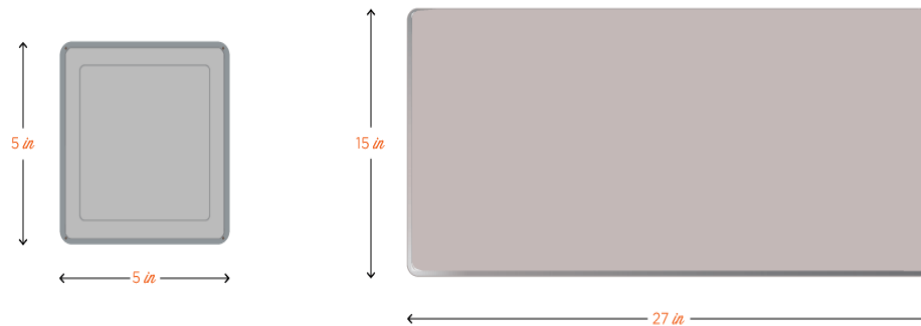

Figure 5: RFID Antenna size comparison

3.2.2 Indoor or Outdoor

Since we are building a Wardrobe management device, the system design is an indoor system. The indoor system will keep things simple to design and no need to require any other applications to make it work properly. Is important to know that an outdoor design will require some additions to protect the antenna and the whole system work. For example, if it was an outdoor design, it would require ingress protection, known as IP, for water and dust protection, since it would be exposed to those and the overall design would cost more to be protected to keep it working without any issues.

3.2.3 External or Integrated

RFID antennas can be integrated with the reader as one device, as for the external is to be purchased separately as an external piece of hardware. Integrated a reader and antenna provides certain options to consider:

1. **Compact vs Bulky:** A compact design antenna has some challenges. Since we are designing an antenna, a compact design would be challenging to make. As we start working with the specifications and the requirements for the antenna, design would probably end up being bulky.
2. **Easy to install vs More complex to install:** An integrated antenna makes things easier since everything is inside the reader module. It won't take any complications if we compared it with an external antenna. An external antenna would require more space and adding more outside components that makes things complex to integrate.

3. **Low to Mid-Gain vs More Gain options:** An integrated antenna would not provide a lot of gain since the limitations of the fixed antenna size inside the reader. On the other hand, an outside antenna has more flexibility to increase/decrease those gain values. The values of gain would be easier to perform since we can be able to get what we need.
4. **Limited vs More choices on beamwidth and directionality:** Integrated antennas, like we mentioned before, are inside readers and their values are fixed. This means that we cannot alter any of the specifications that this already contains. For an external antenna, we can make such changes to make our antenna have the specs we need. In terms of beamwidth and directionality, we are able to work in more detail to get it work based on our needs.
5. **Suitability of most applications' vs Small applications:** An integrated antenna gives a lot of limitations to make it suitable for most applications. For an external antenna, it makes things a lot easier to cover more applications compared to an integrated one.

To conclude, an external antenna provides more functionality and flexibility compared with an integrated antenna. That is why we are considering designing it to be able to get the values and the specifications that will make it work.

Table 3: Specs for our RFID antenna

External RFID Antenna
Bulky
Complex install
More Gain Options
More choices on beamwidth and functionality
Suitable for most applications

3.2.4 RFID Energy Flow

The energy flow through an RFID system is important to understand the way an RFID works. Energy enters an RFID through a power cord or ethernet connection directed to the RFID reader, out one of the antenna ports and into the center pin of an RFID cable. Energy is sent to the cable, and some of this energy is lost depending on the length and the insulation of the cable. Energy moves to

the opposite center pin, where the center antenna connection is located on the grounding plate and to the radiating component, radiated out in the form of RF waves toward the RFID tag.

In our antenna design the energy flow would mostly depend on the size and the area of the RFID waves. Those factors should be taken into consideration to make sure it reads the RFID tags and keep it consistent. It is important to know how much energy would require to the specifications the antenna would need. Since we mentioned earlier that the antenna size would not be that big, we can say that the energy flow of our design is not going to produce that much energy flow. One of the biggest things with our design is considering it to be more energy efficient. For example, Low-frequency RFID tags do not require too much energy to be read. Our reader specs are great on using power of no more than five volts, and all the components we are going to use are great to keep power minimal.



Figure 6: RFID antenna cable integration

3.2.5 Circular or Linear

One of the most important factors of designing an RFID antenna is how they radiate and receive RF waves. Polarization is the geometrical direction of the wave's oscillation. There is two ways of how the RF waves oscillate, which is either linear or circular.

Linearly polarized antennas in a single direction, making them not as flexible in certain angles and heights. For a RFID tag to be detected, the tag should be horizontal to the antenna at a consistent height. A circularly polarized antenna works well on applications where the tag item's location will not be known or will be at different angles and heights.

There are two types of circularly polarized antennas that are differentiated to the way they rotate: Right-Hand Circularly Polarized (RHCP) Antennas rotate counterclockwise, and Left-Hand Circularly Polarized (LHCP) Antennas rotate clockwise. The use of these types of Circularly polarized antenna would most depend if they needed to be used on two RFID Readers in the same area. If we have two RFID readers facing each other, it is important to know that if we keep to the same antennas, either LHCP or RHCP, facing each other, the ways could collide and cause a null zone in which in the middle tags cannot be read.

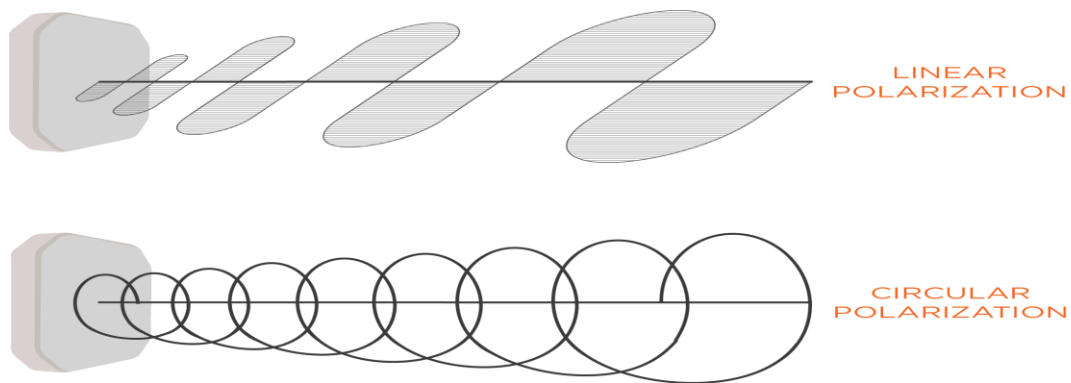

Figure 7: Linear Polarization vs Circular Polarization

3.2.6 Far Field or Near Field

The most important characteristic of an RFID antenna is the read range. Several factors determine the read range generated by an RFID antenna such as reader transmit power, amount of cable loss, coupling technique, antenna gain, and antenna beamwidth.

A key aspect of any RFID antenna is whether it is a far-field or near-field antenna. The difference in the two is the way in which they communicate with an RFID tag.

Near-field RFID antennas typically use magnetic or inductive coupling to communicate with the tag when it is near the vicinity. Near-field antennas are

limited to read no more than a foot away since their magnetic field and the tag antenna's magnetic field have to be close enough to send and receive information.

Far-field antennas use backscatter to communicate. Backscatter is a communication method in which the antenna sends energy to the tag, which powers the integrated circuit (IC). The IC then modulates the information and sends it back using the remaining energy. As opposed to the Near-field RFID Antennas, Far-field antennas can communicate with passive RFID tags up to 30 feet or more in an optimal environment.

Long read range does not always mean optimal. If we limit the space, a greater read range could cause problems due to reading too many tags at once instead of one specific tag or group of tags at a time.

For our specific design, Near-Field would be enough for our antenna to read the Low-frequency RFID tags. Since most of our components are power efficient, there is no need for us to create a Far-Field antenna. The Wardrobe Management system does not need that long range to read the RFID tags. Supposing that we create a Far-field read range, what is going to end up happening is that it will read all the RFID tags without the user's consent. We just want to cover the read range limitations of the RFID tags which is 5 to 10cm away. That's enough for us and would not create any problems with the applications that we need our antenna to perform.

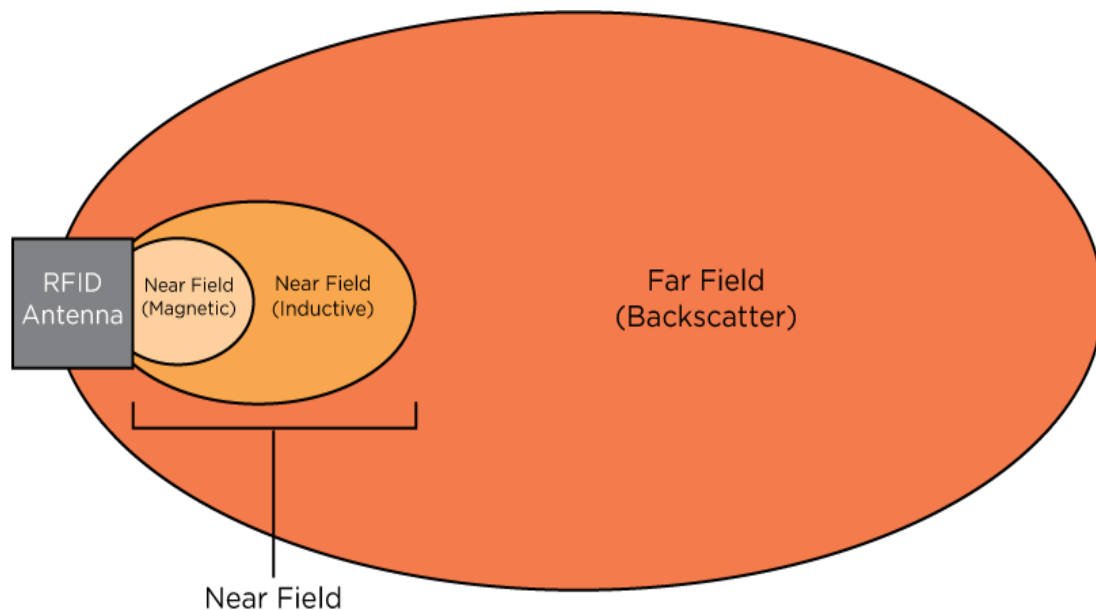

Figure 8: Near Field vs Far Field

3.2.7 High Gain vs Low Gain

Antenna gain is expressed in decibels (dB) and is a logarithmic unit of measurement of the ratio of two powers. For designing our antenna, we are considering using different units of measure depending on the aspects of the antenna. For example, dB is to measure the antenna power input over output. dBW is to measure the antenna's power in watts. dB is the antenna's power of a half wave dipole antenna. Lastly, dB is the antenna gain of power required to produce a field of EM.

When we get to the design constraints, each of these measurement values would be used accordingly to their respective applications. We can say that these are going to be used frequently to make that antenna work since dB is a measure for power. Decibels are important to measure antennas since they provide a better scale than linear values.

3.2.8 Wide or Narrow Beamwidth

Beamwidth is very closely related to gain and is exactly what the name implies – the width of the beam or RF field. There are two different fields: the azimuth and elevation fields. Both can have a beamwidth to understand where the RF waves will be directed. Linearly polarized antennas have a relatively small beamwidth in one field between 30 degrees and 360-degree beamwidth in the other. Most linear antennas' specifications note the elevation and azimuth beamwidths to the same degree because the antenna can be physically turned 90 degrees to show the opposite beamwidth.

As we know, the higher the gain, the smaller the beamwidth. We are going to decide what is more important for their application, a greater length of read with a small width, or a shorter read length and wider RF field.

For our design applications, our antenna would not need to have a narrow beamwidth. Like we mentioned in other sections, we do not need to require any complications that are not necessary for our antenna to perform. A Linearly polarized antenna would be enough to read those RFID tags. This antenna particularly will be perfect to read and send the RFID tags information to the reader and our other components that will access that information to complete the necessary tasks. Also, the angle limitation is not a constraint at all since the user would have the ability to scan the RFID tags without a problem. The location of the RFID antenna would make scanning RFID tags easy, without any complications.

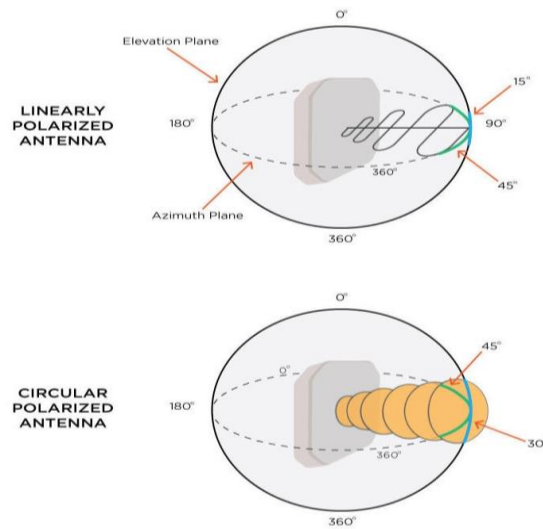

Figure 9: Linear Polarized Antenna vs Circular Polarized Antenna

3.2.9 Directional vs Omni-Directional

On this specification of the antenna, we are looking at directivity, which is defined as the antenna's ability to focus on a particular direction(s) to transmit or receive energy. There are two types of antennas in terms of directivity: directional and omni-directional.

For the directional antenna, have a concentrated beam width that covers one direction that is intended to cover between 25 to 75 degrees to detect the RFID tag. Every other angle outside that range would not be able to read. As for the omni-directional antenna it covers an entire plane and would cover 360 degrees area spectrum. Even though it covers more area than the directional antenna, it still has two locations that the RFID tags cannot be read, the top and the bottom of the antenna. Learned from EMF class, current flows create a magnetic field, either clockwise (current going up) or counterclockwise (current going down). In the picture above, it shows both antennas and what areas are covered to be able to read the RFID tag.

The external RFID antenna that we are going to design needs to consider these two options. Based on our needs, and the functionality of our system, a directional antenna would be a better fit. An Omni-directional antenna provides more angles to scan the RFID tags, we still don't need to cover a 360-degree scan. The Wardrobe Management system would keep things simple. We want to keep our RFID antenna stick to a wall, meaning that there's no need to have an omni-directional antenna. Also, to prevent any reading problems, keeping a directional antenna would make the user get the RFID tag close to the RFID antenna making

sure that the piece of clothes he/she is scanning is the one that they're going to use.

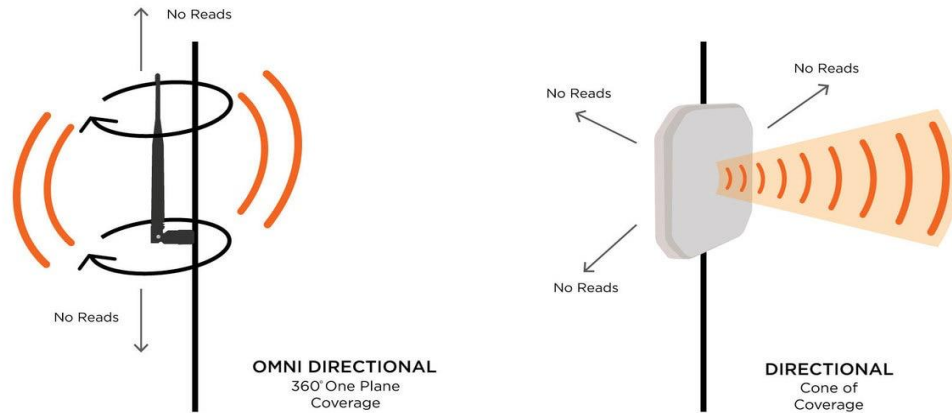

Figure 10: Omni-Directional vs Directional antenna

3.2.10 Overall design of our antenna

The antenna is one of the most essential elements of our design. If the antenna does not work properly, the other components are not going to be able to get the information of the RFID tags and do their different applications. That is why it is important to consider all the specifications that we mentioned to be carefully selected to make this an easy task. The antenna would be connected to the reader, which will take the RFID tags information to send it to the microcontroller to edit or make any changes. We will make this antenna considering using a copper wire cable and based on our specifications, make different models and tools until we get one that covers all our needs.

3.3 RFID Reader

In this section we are going to introduce the RFID reader specs, power requirements, characteristics, and how the antenna is going to be connected to it to be able to scan RFID tags.

3.3.1 ID3-LA RFID Reader

For the RFID antenna to work, we need an RFID reader. The RFID reader is the element that will pick up the RFID tag that was collected from the antenna and sends the information to the microcontroller. Based on the specifications of the RFID tags and the antenna, we want to use an RFID reader that can read 125KHz RFID tags, so that we can build an outside antenna. During our research on the internet, we found a reader that suits those needs. From the company ID-innovations, we are going to use the ID-3LA reader.

Most of the RFID readers on the market have integrated antennas and that's not what we want. We want to be able to build it as part of our Senior Project design and make it work.



Figure 11: Photo of the ID-3LA reader

3.3.2 ID-3LA Specs

In the next figures/tables, we are going to show the ID-3LA specifications:

Table 4: Device operational Characteristics

Parameter	ID-3LA
Frequency	125KHz
Card Format	EM4001 or compatible
Read Range ID3	Up to 30 using suitable antenna using ID-Innovations clamshell card @5V
Read Range ID13	Up to 12cm using ISO card, up to 18cm using ID-Innovations clamshell card @5V
Read Range ID23	Up to 18cm using ISO card, up to 25cm using ID-Innovations clamshell card @5V
Encoding	Manchester 64-bit, modulus 64
Power Requirement	+2.8 VDC thru +5 VDC
RF I/O Output Current	+/- 200mA Peak to peak
Certification	Ce, C-TICK, ROHS, FCC

Based on the ID-3LA operational characteristics, we can observe the frequency of the reader that matches our Low-frequency tags. Also, the reader itself requires just a power of no more than +5 VDC to work, making it an energy efficient reader.

1. GND
2. RES (Reset Bar)
3. ANT (Antenna)
4. ANT (Antenna)
5. CP
6. Tag in Range
7. Format Selector
8. D1 (Data Pin 1)
9. D0 (Data Pin 0)
10. Read (LED/Beeper)
11. +2.8 thru +5.0V

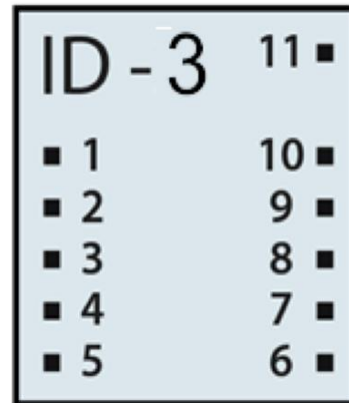

Figure 12: Pin out for ID-3LA

Looking closely at the pins on Figure F, there's two pins that are dedicated to the Antenna. Pins 3 and 4 would be used to connect the antenna.

Table 5: Pin description & Output Data formats

Pin #	Description	ASCII	Magnet Emulation	Wiegand26
Pin 1	Zero Volts	GND 0V	GND 0V	GND 0V
Pin 2	Strap to Pin 11	Reset Bar	Reset Bar	Reset Bar
Pin 3	To External Antenna	Antenna	Antenna	Antenna
Pin 4	To External Antenna	Antenna	Antenna	Antenna
Pin 5	Card Present	No function	Card Present*	No function
Pin 6	Tag in Range (Future)	Tag in Range	Tag in Range	Tag in Range
Pin 7	Format Selector (+/-)	Strap to GND	Strap to Pin 10	Strap to +5V
Pin 8	Data 1	CMOS	Clock*	One Output*
Pin 9	Data 0	TTL Data(inverted)	Data*	Zero Output*
Pin 10	3.1 KHz Logic	Beeper/LED	Beeper/LED	Beeper/LED
Pin 11	DC Voltage Supply	+2.8 thru +5.0V	+2.8 thru +5.0V	+2.8 thru +5.0V

*Requires 4K7 Pull-up resistor to +5V

Table 6: Absolute Maximum Ratings

Pin Number	Pin Function	MAX Voltage/Amp
Voltage applied to Pin 2	Vcc	5.5 V
Voltage applied to Pin 2	Reset	Vcc \pm 0.7 V
Current drawn from Pin 3	Antenna	+/- 75mA
Maximum 125KHz RF voltage at Pin 4	Antenna	+/- 80 Vpp
Current drawn from Pin 5	Card Present	+/- 5mA
Current drawn from Pin 6	Tag in Range	+/- 5mA
Voltage at Pin 7	Format Selector	Vcc \pm 0.7 V
Current drawn from Pin 8	Data 1	+/- 5mA
Current drawn from Pin 9	Data 0	+/- 5mA
Current drawn from Pin 10	Beeper	+/- 10mA
Additional Pins 5,6,7,8,9,10 may not have voltage exceeding		Vcc \pm 0.7 V

8.2 Circuit Diagram for ID-3LA

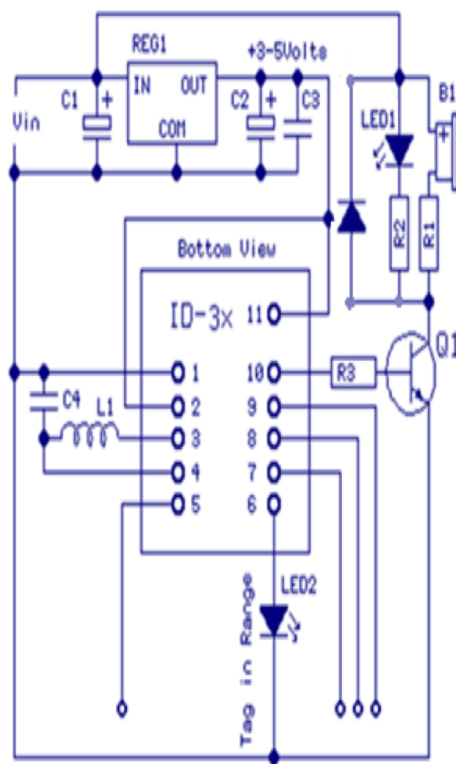

Parts List	
Part #	Value
R1	100R
R2	4K7
R3	2K2
C1	10uF 25v electrolytic
C2	1000uF 10v electrolytic
C3	100nF
L1	1.337mH
Q1	BC457 or similar
LED1	Read LED
LED2	Tag In Range LED
B1	2.7khz – 3kHz 5v PKPK AC

Figure 13: Circuit Diagram for ID-3LA

On Figure H, it shows the ID-3LA circuit diagram. It shows some components outside the reader if we are considering adding things like sound, LED lights, among others. On the right side, it shows the parts list that needed to make any of this to work.

3.3.3 Consideration of Adding other external components

Our main goal is to use this reader and connect the antenna and the microcontroller. It would be possible to add some other components as well to make our project more attractive to the public. Considering a LED2 light to insert on pin 6 is a great concept to let the user know that the RFID tag is in range. It does not seem like a difficult task to do. In fact, the user will know if the tag was scanned without checking the phone app.

Another component that can be consider it's the LED1 light. This one would let the user know if the tag was read. Now this one requires to relate to some other components to work. Pin 11 is where the DC voltage supply is connected and this LED1 light is in parallel with C1, R1 and R2.

3.3.4 Designing Coils for ID-3LA

Based on the ID-3LA specifications, the recommended inductance is 1.337mH that needs to be used with the internal tuning capacitor. We are trying to build an antenna that covers at least 10cm away. To get that range, we are building a bigger antenna so it can provide enough magnetic field strength to excite the tag. In order to do this, we need to buy copper wire.

3.4 Wire

This wire section we introducing the copper wire that are going to be use in order to build the antennas. Copper wires comes in different thicknesses and we need to choose the right ones that will work based on LF RFID tags.

3.4.1 Copper Wire

To create an antenna that can produce an electromagnetic field, we need to use copper wire. Copper wires come in different diameter sizes and base on those sizes they have a designated number. The American Wire Gauge, known as the AWG, provides a table with details of each one of the sizes available on the market.



Figure 14: Copper wire to be purchase

3.4.2 AWG (American Wire Gauge)

The American Wire Gauge is a standardized wire gauge system for the diameters of round, solid, nonferrous, and electrically conducting wire. This system is used in the United States to measure the diameter of wires. In this situation, we are going to use it to measure the thickness of the copper wires.

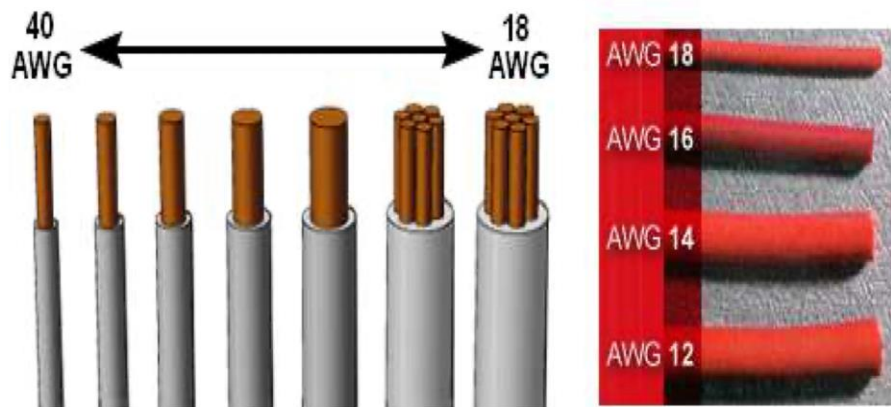

Figure 15: AWG cables/ wire sizes

On Figure K, we can tell that the thicker the wire, the higher the number. To design our external antenna, we need to consider the AWG. To create an EMF, it is important to have the copper wire turns close to each other. Below we have a table with the different diameter sizes depending on the AWG number.

Table 7: Standard Wire Gauge Chart

AWG	Diameter (mm)	Area (mm²)	Resistance (Ohms / 1000 feet)	Max Current (Amps)	Max Frequency For 100% skin depth
28	0.32	0.081	64.9	0.226	170KHz
29	0.287	0.064 2	81.83	0.182	210KHz
30	0.226	0.050	103.2	0.142	270KHz
31	0.226	0.040	130.1	0.113	340KHz
32	0.203	0.032	164.1	0.091	430KHz
33	0.180	0.025	206.9	0.072	540KHz

Since the ID-3LA is a low power, we can build an antenna with copper wire that will not use a lot of current. Also, looking at Table F, looking at the max frequency column, we can consider buying some copper wires with a AWG of 27 or higher; since our RFID tags have a frequency of 125KHz. With that said, buying no more than three copper wires to get the 10cm read range.

3.5 Transponder (tags)

Description specifications and details regarding RFID transponders used for the project.

3.5.1 General information

As stated previously, and seen in figure 1, the building block for an RFID system is the transponder, or RFID tag. These tags are divided into two subcategories active and passive. An active tag uses an internal battery source to power the circuit and send radio signals. The battery power allows the active tags to broadcast at higher frequencies, 805 to 950MHz. This allows for a maximum hypothetical range of 100 feet. A passive RFID tag is much more commonly utilized in everyday applications and does not require a battery. The energy from the electromagnetic field, once in range of the antenna, is enough to power the passive tag. The maximum range is typically limited to a 20-foot range. The passive tag is then subcategorized again into read-only and read-write. Regardless of how the transponder is categorized it contains an Integrated Antenna and a Microchip as depicted by the figure below.

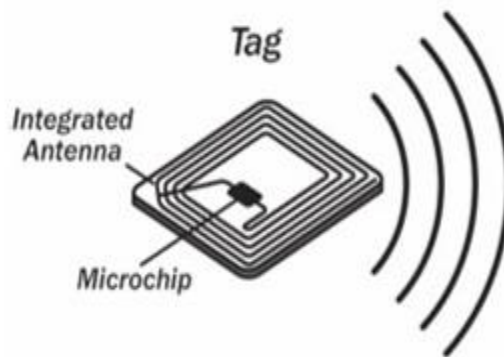

Figure: 16 RFID tag

As stated previously all tags contain an integrated circuit that manages the identification and communication. Despite having a maximum range associated with specific frequencies a 125KHz frequency is typically used for short ranges that only consists of a few centimeters. A 13.56 MHz is then used when detecting objects from one or two meters away. The range of the system is primarily dependent on the type of RFID tag and the antenna design. There are other factors that influence it as well like line of sight, conductive objects, and general interference, like other RFID systems and Wi-Fi.

3.5.2 History of RFID

The major design decision that the group had to make was whether to utilize an active or passive RFID tag. As stated previously passive tag does not have its

own power supply and waits for a signal from the RFID reader, which then sends energy to the antenna which then converts the energy into a radio wave that is sent to the read zone. A passive tag only consists of two main components: the tag's antenna and the integrated circuit or microchip. When the tag is read within the effective scanning range the internal antenna transfers the radio frequency energy to the integrated circuit and the chip. This then generates a signal that is sent back to the RF system. This process is known as backscatter. It refers to the alterations that occur in the electromagnetic waves which are used by the system to interpret information.

RFID inlay is a common term for the basic structure of passive RFID tag that only consist of an antenna and integrated circuits. There are numerous other types of tags, but the two major denominations are inlays or hard tags. A hard tag is more durable because it can be made of plastic, metal, ceramic, or any other material. Their size and shape are completely independent and can vary drastically depending on their intended purpose and designed specification. Beyond this general categorization there are even further methods of dividing hard and inlay tags.

There are high temperature inlay tags, which as the name suggests are designed to withstand extreme temperatures from both spectrums to monitor system performance and reliability. Like the previous tag there are also rugged tags. These tags are designed to withstand and function under extensive environmental conditions, like, snow, ice, sand, or even extensive dust. Size matters as well because certain products have size constraints on for their tags. Finally, there are also embeddable tags. Embeddable tags are hidden in small crevices and are covered with epoxy so that the tag itself cannot be harmed easily. Some of these specifications aren't mutually exclusive from another and can be applied to both hard and inlay tags.

Inlay tags are very cheap and can have an average price as low as \$0.12 per tag, when purchased in bulk. Despite being significantly cheaper there is no major performance disadvantage when working with inlays over hard tags. There are three major types of inlay tags: dry inlays, wet inlays, and paper face tags. A dry inlay is an integrated circuit and antenna attached to a material called a web. They are laminated and typically come with adhesive properties. Wet inlays consist of the antenna and integrated circuits being attached to material like PET or PVT. They are typically clear and have adhesive properties. Paper face tags are simply wet inlays with a white paper face on them. These are utilized in situations when a logo or number needs to be printed onto the tag itself.

Passive tags operate at different frequencies that will affect reading range and other vital applications. There are three common frequencies that are utilized. A low frequency system (LF) only has a range of 125-134 KHz. This is an extremely long wavelength that has an approximate range of 1- 10 centimeters. High

frequency (HF) and Near-field communication (NFC) have frequency of 13.56 MHz This would be considered a medium wavelength with a range from approximately 1 centimeter to about 1 meter. Ultra-high frequency (UHF) has ranging frequency from 865 to 960 MHz This is a short, high energy wavelength that has an average reading distance of 5-6 meters. If the tags sizes are increased and ideal conditions are met the UHF can have over thirty meters. As the frequency increases the waves become shorter and higher in energy. This increases the range of the RFID system but negatively affects the accuracy and reading capabilities because interference greatly increases.

An active RFID tag consists of three major components. It contains a reader, antenna, and a tag. They have their own internal power source that allows them to be read from a further distance but also gives them a greater storage capacity. The batteries that power these tags typically last anywhere from three to five years. Currently it is standard practice to completely replace the tag once the battery fails, but it is becoming more common to design active tags with replaceable batteries. The choice of tag ultimately comes down to distance, magnitude of information and environmental conditions the tag is exposed to.

The standard frequencies for active systems are 433MHz and 2.45GHZ. The internal power allows the wavelength to become longer and not be as easily influenced by external factors that could hinder the signal from being transported. Two main types of active tags are transponders and beacons. Transponders work similarly to a passive RFID system. The first step is for the reader to send a signal to the tag which then activates the transponder. Once activated it will send the signal back to the reader with the necessary data. Transponders have the added advantage of being energy efficient because until the tag receives a signal from the reader it will conserve power by not turning on fully. This is the main difference between the transponders and beacons. A beacon will not wait for a signal from the reader but continuously send out specific information every three to five seconds.

3.5.3 Passive vs Active RFID

After considering both Active and passive tags, and all their sub categorizations, the group decided to go with a pass tag. This really wasn't much of a debate because passive tags are cheaper and easier to apply than an active tag. An active tag would have been completely overqualified for this RFID system. One of the basic requirements for the inventory management system is to have a range of approximately 10cm. A passive tag can easily meet this requirement on the lowest possible frequency of 125KHz. An active tag would not only have been unnecessary, but it wouldn't allow the project to function properly because the intended space for it is confined to the area immediately outside of the closet

space, or near it. The active RFID tags would continuously read the items in the closet and not work properly. Active tags are also just too big to easily fit on the designated items and would have created a Hassle for the user every time they wanted to withdraw something and then use it.

The next step was to decide what kind of passive tag was going to be utilized, hard or inlay. This decision was a little trickier because in terms of capability there is no significant difference. After considering the desirable outcome of the system the group went with the choice of a dry inlay tag. RFID tags typically are small and not noticeable but while walking around there is the possibility that the tag will fall off or get damaged in a significant way. Another consideration is that of doing laundry. The tag should either be easily removable from the clothing or be attached to a cloth's hanger. Then every time the user wishes to categories their wardrobe, they should have the RFID tags ready to be paired with a certain article of clothing. This might add some inconvenience to the user in the initial set up of the automation system, but the time invested will be repaid once the user decides to organize and manage their closet.

The final passive dry inlay RFID tag is shown below in the figure. It is a 125KHz EM4100 RFID soft paper sticker tag, with a diameter of 30mm. It only has the read ability and is lacking the write capability. The tag has adhesive properties, but these will probably be altered. Most likely it will be attached to a Velcro strap that will allow for easy attachment and removal of the tag from the specified article of clothing. The frequency of the tag as stated before is 125Khz. This allows for an effective range between 1 and 10 cm. The main reason for choosing this frequency is to address the issue of accidentally scanning other items in a closet while they are supposed to be stored away.

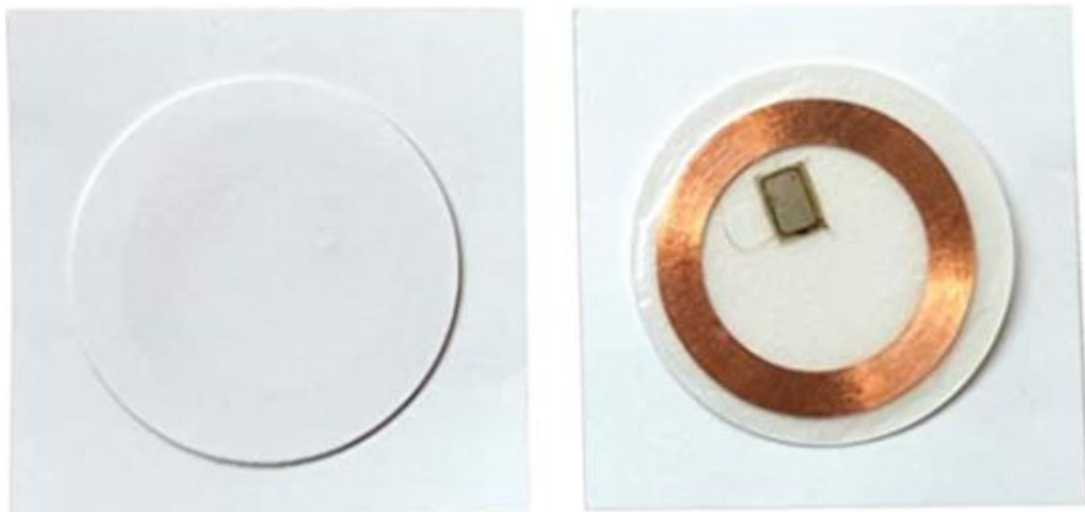

Figure 17: Passive tag used in project

One issue we will encounter using these tags is that of reusability. The description of the tags states that each one comes with a unique identification and that they cannot be altered. If a tag is damaged or lost that specific identification is lost. This shouldn't be too much of an issue though because multiple tags can be assigned to the same piece of clothing and even though the tags themselves cannot be rewritten the way they are paired in the database can be altered. The hardware limitations can be compensated with software alterations.

Also, the fact that the tag is blank will allow the user to customize them in an insignificant manner for the system, but in a convenient way for the user. They can color in the dot with the specific color of the clothing. Or if they chose to be more specific, they even have the possibility of putting writing a number or special symbol if they really like a certain piece of clothing. The group made the conscious to keep the hardware aspects, that the user directly interacts with frequently, simple so that as little errors as possible happen on the users end instead of the technical end.

Table 8: comparison tags

Active	Passive
<ul style="list-style-type: none"> · Stronger signals that are able to travel greater distances · Less prone to interference, both environmental and technical because of high frequency. · More expensive · Contain a internal power supply · Larger in size because of the extra components · Not easily damaged but typically not replaceable if power supply dies · Have the ability to be rewritten. 	<ul style="list-style-type: none"> · Smaller and cheaper than active tags. · Do not contain an internal power supply · Have long lifespan and are easily replaceable because of relative simplicity · Are easily damaged because of flimsier design compared to active tags. · Not all of them have the ability to be rewritten · Easier to jam and prone to environmental disturbances because of lower frequency.

3.6 Power supply

Comparisons of different power supplies, specifications, and part selections for the final circuit design.

3.6.1 AC Versus DC

Electric signals are the fundamental building block of any circuit. An electric signal is defined as a voltage or current which transports information, most commonly in applications it refers to voltage though. To function properly an electronic device requires power. The equation for electric power is voltage times current, or $P=V \cdot A$. Alternating current (AC) and direct current (DC), are utilized to refer to voltages, electric signals, and currents. Alternating current, as the name implies, does not exclusively flow in just one direction. It continuously changes but follows a pattern, switching between positive and negative. The rate of change for AC is known as frequency, numbers of cycles per second measured in hertz.

One important factor in analyzing AC signals is root mean square (RMS) values. The value of an AC voltage, for example continuously fluctuates between the positive and negative peaks. During much of this time the voltage is not at its peak value. To properly analyze this AC voltage and receive an accurate assessment of its outcomes it needs to be measured differently. This adjusted value is known as root mean square voltage and denoted as V_{rms} . It is simply the peak voltage times 0.7. When designing or making other power related decisions this value should be utilized if an AC voltage is involved.

AC supplies can power certain electronics but for most electronics it is necessary to use regulated DC supply. DC always flows in the same direction, but it can increase and decrease along the same axis. DC voltages are either always positive or negative, but never both. As stated previously most electronics require a consistent DC supply in order to function properly. In order to operate most efficiently this DC supply should be smooth and only have small ripple in it. Batteries, cells and regulated power supplies offer this steady DC. There are many different power supplies that have varying functions.

3.6.2 Power supply basics

The main functions of these supplies are to convert high voltage AC to a specific low voltage supply. It could also simply alter a DC supply in order to achieve a desired output or regulation. There are typically four major parts that can be used when making a power supply. Transformers step down high voltage AC

mains to low voltage AC. Rectifier converts AC to DC, but the output is not consistent. Smoothing is responsible for smoothing the DC voltage from varying too much and turns the output into a small ripple. Regulator is responsible for eliminating ripple by setting the DC output to a fixed voltage. The structure of a power supply can vary but it can be broken down into a simple block diagram depending on what the user is trying to design.

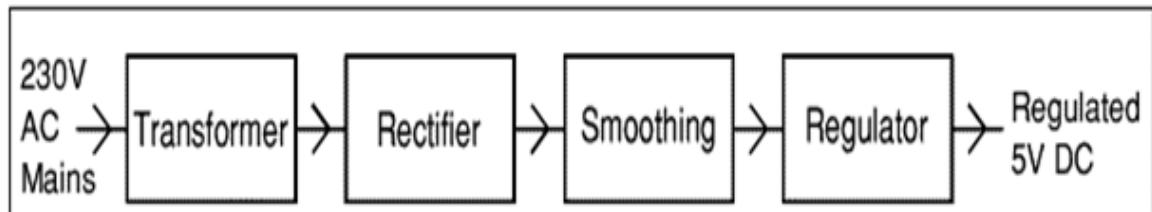

Figure 18: Block diagram of a regulated Power system

There are many different variations to this specific power supply and the specific design is dependent on the end goal of the system specifications. A voltage regulator that consists of only a transformer is optimally for things like lamps or heaters, but not electronic circuits. A transformer and a rectifier create a varying DC output which is ideal for standard motors, but not electronic circuits. A power supply consisting of a Transformer, rectifier and smoothing creates an output that is suitable for many kinds of electronic circuits. Finally, a power supply consisting of all four major components is suitable for every kind of electronic circuit. The more precise the output of power supply is, the easier it can power a circuit reliably with better performance.

Transformers convert AC electricity from one voltage to another with a minimal loss of power. They exclusively work with AC electricity. There are two kinds of transformers: step-up and step down. Step-transformers increase voltage and step-down reduces it. It is more common to use a step-down transformer because in North America domestic electrical outlets supply 120 volts. In Europe domestic outputs supply between 220 to 240 volts.

Transformers are very efficient and waste very little power. The power out is almost equal to the power in most cases. Typically, as voltage is stepped down current is stepped up to keep the approximate power the same. There are two major components for transformers. The input/primary coil and the output/secondary coil. There is no direct electrical connection between the two coils but are instead linked by an alternating magnetic field. This magnetic field is created in the soft-iron core of the transformer. Another important aspect about transformers is the turns ratio. This is the ratio of the number of turns on each coil and determines the ratio of the voltages. IT also determines if the transformer will be step up or step down.

The next major component is the rectifier. This specific part of the power supply is responsible for converting AC to DC. There are many ways to utilize diodes to create a rectifier. Two of the most common forms of rectifiers are the bridge rectifier, which produces full wave varying DC. Then there is also the single diode rectifier, which only uses the positive parts of an AC wave to produce a half-wave varying DC. A bridge wave rectifier can be created using four individual diodes. It is called a full-wave rectifier because it uses all the AC waves, both the positive and the negative halves. Bridge rectifiers are typically only used if the electronic device requires a lot of power to operate successfully. Single diode rectifiers are typically only used to supply electronic circuits that require a very small current.

Another vital component of a power supply is the process of smoothing. Capacitors are responsible for the smoothing process, and they are typically large value capacitors. These components are connected across the DC supply to act as a reservoir which supplies current to the output once the varying DC voltage from the rectifier begins to fall. The figure listed below shows the diagram of a capacitor and its effects on the DC line. The dotted line is the typical behavior for the unsmoothed DC while the solid line is the DC with the smoothed one.

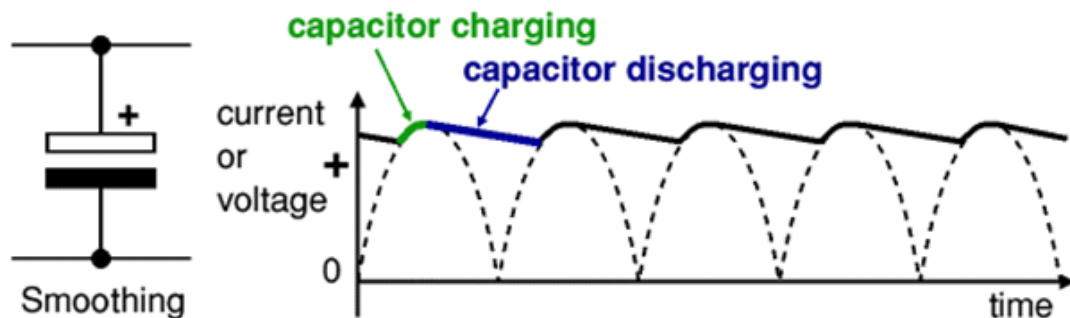

Figure 19: Smoothing capacitor and effects on current or voltage.

This is very advantageous because the smoothing process, as seen in the figure above, ensures that the DV voltage continues to stay near the peak. This process is not perfect though and there is still a fluctuation of DC wave when the capacitor discharges. Every time a capacitor discharges and continues to lower it creates a minor ripple voltage. Typically, this is not an issue because for most circuits a 10% ripple supply voltage is not enough to cause the system to not work accurately anymore. The larger a capacitor is the smaller the ripple will become. There is a slight variation when designing with a single diode rectifier that only produces a half-wave varying DC. The capacitor value needs to be doubled if the rectifier only draws from half of the AC voltage instead of both the negative and positive ends.

The final piece of power supply is known as the regulator. There are many different types of fixed output voltages, but the most common ones are either 5V, 12V or 15V output regulators. Besides the fixed output the other way of choosing a fixed regulator is categorizing it by the maximum current that they can pass while still working properly. Despite these limitations many regulators have built in fail safes that will guard them against excessive current, overload protection, and overheating, thermal protection. Fixed voltage regulators typically have 3 leads and look very similar to power transistors. It is not required though to choose from an existing voltage regulator, and they can be designed instead of pre bought.

A Zener diode regulator is a common self-designed voltage regulator. These are well suited for low current power supplies. The most basic one can be designed using only a Zener diode and a resistor. Zener diodes are characterized by their breakdown voltage V_z and maximum power P_z . Other calculations need to be made to choose the appropriate Zener diode. Zener voltage, input voltage, maximum current and Zener power are all required to make the design decisions. The resistor is responsible for limiting the current. While in the resistor the current is constant and when there is no output current the Zener diode and its power rating has to be able to withstand the current that is not flowing into the resistor.

3.6.3 Batteries

Another form of powering an electronic is using batteries. There are many different types of batteries and they can be seen everywhere from watches to smoke alarms. Batteries are continuously innovated on and tweaked, so that they can last longer or deliver more energy efficiently. A battery is a chemical device that stores electrical energy in the form of chemicals. It uses an electrochemical reaction to transform the directly stored chemical energy into DC electric energy. The electrochemical reaction in a battery is accomplished by the transfer of electrons from one matter to another through an electric current.

The term battery is most used to describe devices that undergo this electrochemical process. The specific unit responsible for the storage of energy is a cell. Three components make up a cell and these are two electrodes and electrolyte and consist of terminals, separator, and a container. Electrodes themselves are either anode or cathode. The anode is the negative electrode. Its purpose is to lose electrons to the external circuit, and during the electrochemical reaction it begins to oxidize. A cathode is the positive electrode. Its purpose is to accept the electrons from the external circuit and during the electrochemical reaction it slowly reduces. The final important component of a cell is the electrolyte. The electrolyte acts as a medium for transfer of charge in the form of ions between the electrodes. It is sometimes referred to as an ionic conductor. Electrolytes are

not electrically conductive but have ionic conductivity. A battery consists of multiple cells that are either connected in parallel or series.

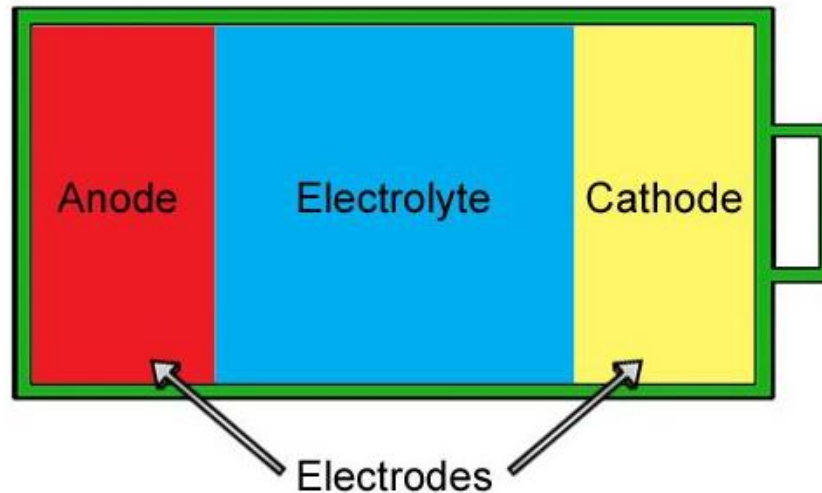

Figure 20: Battery cell diagram

There are two major categorizations for cells and batteries, and these are primary/non-rechargeable and secondary/rechargeable types. These are only the basic categorizations and there are numerous other subcategories relating to batteries. A primary battery is simpler in application because it cannot be recharged and therefore once it runs out of energy it is simply disposed of and then replaced. They are cheap, light weight, small and require very little maintenance. Most primary batteries are single celled and are cylindrically shaped. Secondary batteries have the advantage of being recharged and therefore have a significantly longer life span. This recharging process is accomplished by passing a current through the cells in the opposite direction of the initial charge. Doing this long enough will restore the secondary battery to its original charge.

There are two major ways of applying secondary batteries. In one form of application secondary batteries are used in energy storage of devices, while they are connected to a main energy storage source. They are charged by this device and when needed they supply energy. The second type of application for a secondary battery are the cases when it is used as discharged like a primary battery. When the battery is then low on charge it is connected to a specific charging mechanism which allows it to be used again. The biggest draw back for a secondary battery over a primary battery is that it has a lower energy density. Advantages over primary batteries include high power density, flat discharge curves, high discharge rate and low temperature performance.

In the United States electric outlets, or sockets, have an AC voltage of 120V with a frequency of 60 hertz. AC voltage is easier to transport and transform than DC, and once it has reached a socket the electrical system itself will convert it to the required DC. In the design of this project a major decision the group had to make was whether the project was going to be powered from a wall socket or an independent DC source. After a careful decision-making process, the group decided to go with a DC source over an AC source. This decision had little to do with the design of the system itself but was more based on the user end. Mobility for the scanner is quite important, and ideally it should be very close to or even mounted right next to the wall of the closet. Not every closet has an electrical outlet near it. A cable could have been extended from the device to a wall socket, but the group came to the decision that complete unrestricted mobility was important for this project to work as intended.

3.6.4 Part selection/specification for power supply

After deciding this next major step in the project was to identify which components need power and how much of it. There are two major components that will need power for this system to function properly. In order to help with troubleshooting, and for practical terms of testing, this project will utilize two separate power sources. The main goal is to power the reader module and the Arduino microcontroller. The reader is one of the two major cornerstones for the RFID system to work properly because it is responsible for interpreting and processing the information from the antenna. The reader being used is the ID-3LA and it has a voltage requirement of 2.8V to 5V. The Arduino board also needs to be powered but there are two options of doing so. One is through a micro-USB jack which will regulate the power from 5 volts to the required 3.3 volts. The other option is to simply connect a battery that is between 3.7V and 4.2V to the JST jack.

In order to achieve these required power specifications a large amount of DC voltage will be necessary for the devices to be powered efficiently and for a long period of time. A DC source will be utilized to power the RFID reader of the system. In order for this to be as reliable as possible the DC source will have to undergo smoothing and also go through a regulator. The Arduino board will be regulated by a separate component. It will use a KABOOK 5Pcs DC-DC converter. Only one power regulator needs to be designed for the final project because the converter only requires 6-24 volts which will then power the Arduino and add-ons related to that section of the project. An L7805CV regulator will be used for testing.



Figure 21: Voltage regulator L7805CV

For this project, the source of what kind of power pack to use was an important decision to make. So, the first major part of the power supply would be the DC source. The question was what kind to use and what DC voltage to have. The only thing for certain was that a regulator would be used and that the project should have a relatively long lifespan. Two 12-volt battery packs will be used in to supply this project with the power it requires.

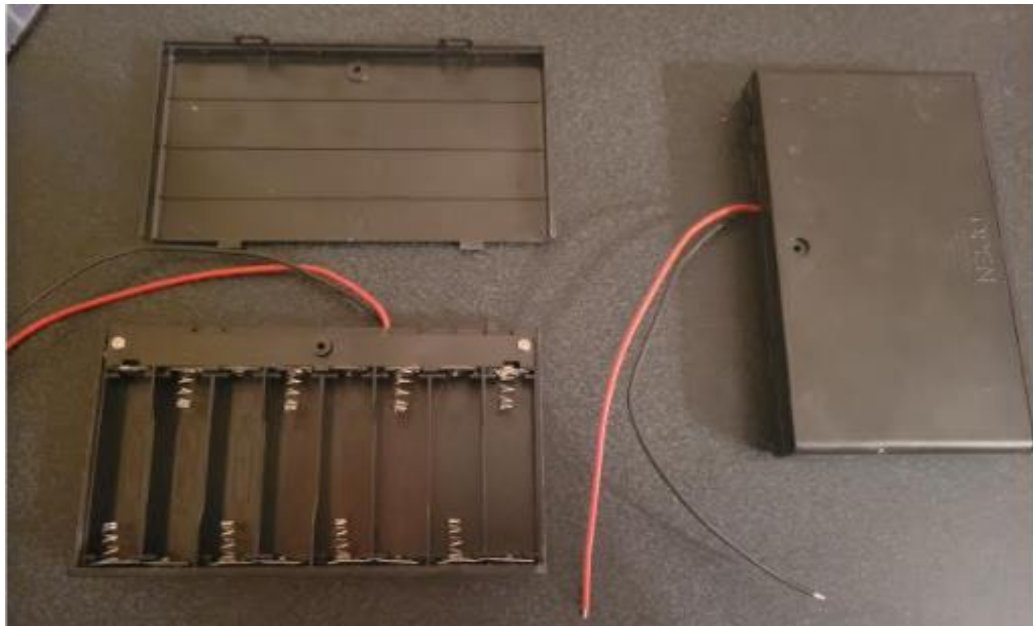

Figure 22: Battery pack

Each pack requires 8 double batteries, at 1.5 volts each and have an on and off switch right on the outside of the case. The main reasons for choosing these large battery packs were the availability of them. At the time of purchase these were the most readily available and affordable. The bonus of a on and off switch will also allow for the user to save power regarding the antenna. The Arduino will be in low power mode, and therefore will typically not be turned off. Another reason for choosing these packs was because it came with two battery packs. It's important to have an immediate replacement incase the original pack fails for some reason.

Even though there will be two sources of power within the circuit there will be a main supply system and a subsystem. The main supply system will be responsible for power the Antenna, reader, and the LCD screen. The sub power system has not been fully decided upon yet. The microcontroller requires 3.3 volt to operate, and the base power circuit will deliver 5V. There are three possible options for the microcontroller to be powered. Expand the power circuit to have two separate outputs, one 3.3V the other 5V. Build a second power regulator that will solely supply power to the microcontroller. Or us a rechargeable lithium-ion battery with a low voltage directly connected to the pin of the microcontroller. Currently the lithium-ion battery is the most likely choice because the microcontroller is the bridge between the hardware and software and is vital for the success of this project.



Figure 23: Lithium-ion battery (probable power source)

The main reason for using a regulator was because in the data sheet for the ID3LA datasheet it described a linear voltage regulator as the ideal source to manage the power. Achieving the desired voltage for the reader is only part of the solution though. Another necessary step will be to meet the current requirements. A simple voltage divider with two resistors would easily be able to achieve the desired voltage. The main issue is that a voltage divider has a very low output current and efficiency.

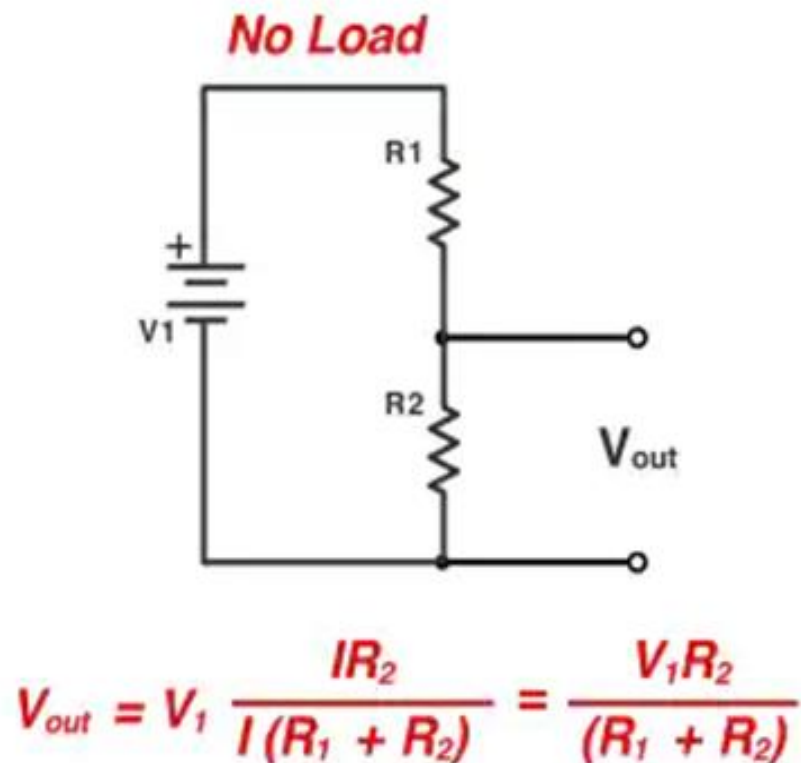

Figure 24: Voltage divider with formulas

It is not the most reliable and therefore is better used for different applications. Another option would have been to use a Zener diode. A Zener diode can produce a voltage from a limited current supply going into the diode. There is a resistor that limits the current coming from the voltage source. The output is much more regulated and stable than a circuit that does not have one. This is ideally suited for very low powered circuits and the output form can be very irregular.

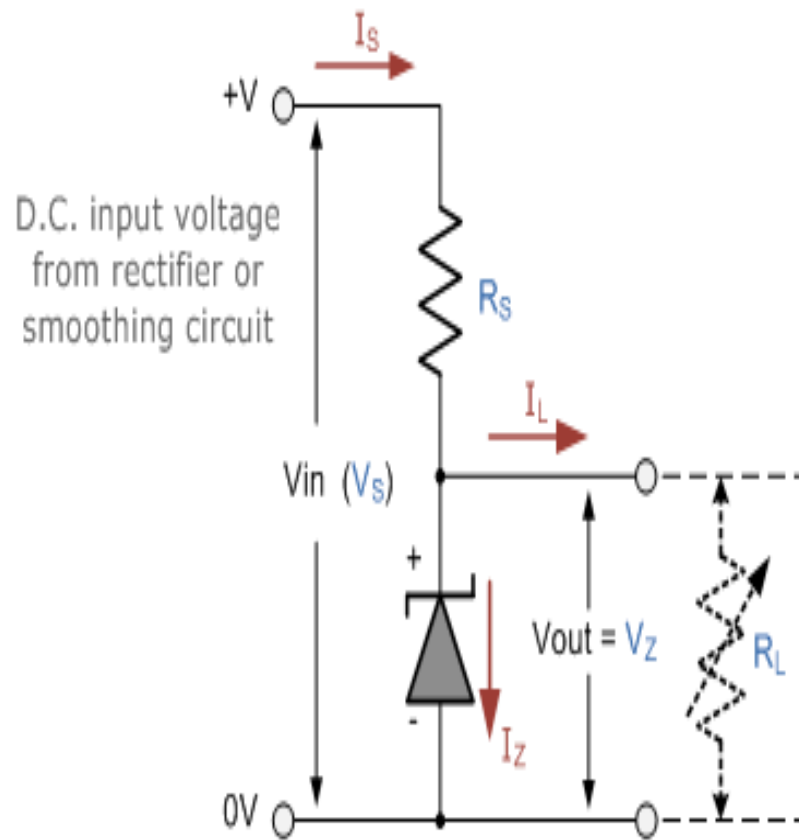

Figure 25: Zener regulator

Specifications.

- Voltage input (max): 35V
- Voltage out (min/fixed): 5V
- Current output: 1.5A
- Operating temperature 0C-125C
- Fixed output type and positive output configuration

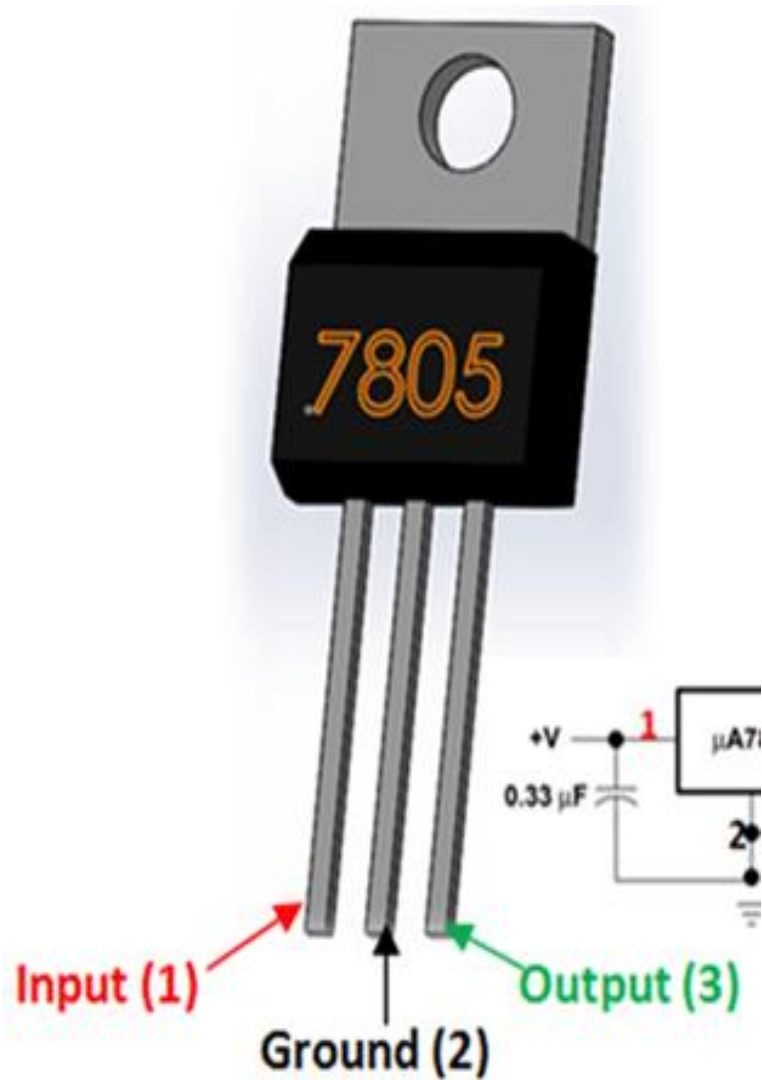

Figure 26: Pins on L7805CV regulator

Despite this being a specific model many 7805 voltage regulators work very similarly to each other and are typically interchangeable. The only reason this specific one was purchased is because of the price and availability online. A 7805 regulator is designed to produce a constant output voltage independent from the input voltage. In today's world voltage regulators are used very frequently in the industry. The name itself tells the user two things about the product. The 78 means that it is a positive regulator and the 05 tells the user that it will provide an output of 5V. The output current should reach an approximate value of 1.5 amps but that can vary due to heat loss. This can easily be rectified with a heat sink though.

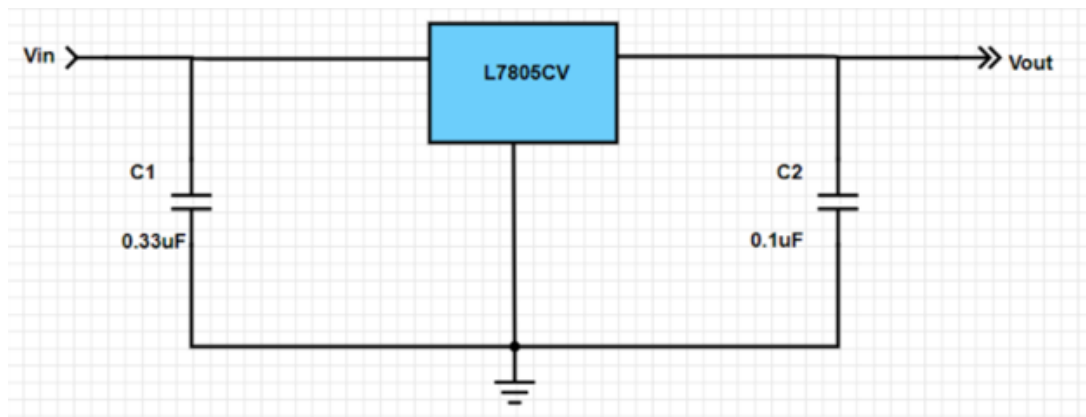

Figure 27: Step down regulator (provided by datasheet)

The figure listed above shows the typical circuit for how a regulator will be used. Simply adding two capacitors, a 0.33uF between the voltage source and the input pin. The second capacitor is 0.1uF and it is connected to the output pin. Ideally these capacitors should be placed close to the pins and they should be ceramic instead of electrolytic. The reason for this is because ceramic capacitors are faster than electrolytic ones. This basic configuration is also used to test the regulators to see that all aspects of the circuit are working properly. The capacitors are important because they are responsible for smoothing the signal so that the devices receive a more accurate DC signal. For the two components receiving power from this circuit this should be sufficient to turn it on and run for a period of time.

Table 9: Comparison power supply

AC source	DC source
<ul style="list-style-type: none">· Single source of power that allows for greater freedom of design.· Requires more components to convert from AC to DC, more expensive and complex.· Limited to locations with power outlets.· Consistent source of power that doesn't need to be replaced.· Location dependent, because it requires a consistent source of power.	<ul style="list-style-type: none">· Offers greater mobility for the final project which will allow the user to choose the location of the project.· Simpler and cheaper to design because it only consists of two major components.· Easier to troubleshoot because of relative simplicity.· Once fully drained will not work and will need to be replaced.

3.6.5 Stretch goals power supply

Despite the final project having two Dc power sources one major stretch goal for the project is to have a version of the project with an AC power supply. One of the major goals of the project was to have it be portable and give the users the choice of setting up the system anywhere they want. Some people would probably probably give up this feature if they don't have to worry about replacing the batteries in the system. Creating an AC power supply would be relatively straightforward with the only two new major components being added to the circuit. A step down transformer that takes 120 volts Ac and transforms it into 12 volts AC. After this the 12 volts AC would be put into a full bridge rectifier to ensure there is no negative AC voltage. From this it could be sent to the Dc regulator, with additional input capacitors, and would be able to power the project.

3.7 Interfacing with RFID reader and connecting to Wi-Fi

In this section we will be going over brief history of microcontrollers and how they will benefit us in this project. In order to interface with the RFID reader, we will need a microcontroller to communicate with it. We will also need a module to connect to Wi-Fi in order to communicate with our database. Properly choosing the correct device and module is an important part to this project.

3.7.1 History on microcontrollers & Our application of the microcontroller

Microcontrollers are behind the scenes when it comes to implementation into our lives. In fact, the average person interacts with at least 20 microcontrollers in their house alone. This number increases the more tech savvy one gets, which is very common today. Microcontrollers are in microwaves, dishwashers, home circuitry, and even in your car's braking system. *"The microcontroller is an embedded computer chip that controls most of the electronic gadgets and appliances people use on a daily basis."* (circuitstoday.com) During 1970-1971 Gary Boone of Texas Instruments invented the microcontroller. He designed a single integrated circuit chip to hold all the circuits of a calculator. He named it TMS1802NC, and it had 5000 transistors which provided 3000 bits of program memory and 128 bits of access memory. Since then, microcontrollers have been growing and advancing at an alarming rate. Everyday people are using microcontrollers to accomplish the little menial tasks we all take for granted. This includes elevators and how they are programmed to return to certain floors after a delay in use.

To the user, microcontrollers are usually hidden from sight and the user interacts with buttons, a screen, or a touch pad. Most of the time there are buzzers and lights integrated to signal events on the microcontroller. Our dive into the microcontroller will consist of our use in interpreting the data from an RFID tag which is a common task in the microcontroller world. Users of our personal wardrobe assistant will solely interface with a small LCD screen and perhaps a few buttons to connect to a Wi-Fi access point to communicate with the database. This project is merely icing on the surface of a cake compared to the vast amounts of applications microcontrollers are a part of, but this proves that the use of microcontrollers can touch every facet of modern human life.



Figure 28: TMS1802NC

3.7.2 Choosing a microcontroller vs building our own device

The crux of our project is what kind of device we will use to interface with our RFID reader, which also can send information wirelessly to our database. This is the most important decision because it will determine how we design the RFID scanner and what kind of system we will use to communicate with our database. We have a several options to choose from to accomplish these tasks. We narrowed it down to some options and we voted on one. The four options being an Arduino, MSP430, Raspberry Pi, Adafruit Feather HUZZAH, or creating our own device to accomplish these tasks.

3.7.2.1 Personal Device

First, I will mention that we investigated creating our own device. Which I will personally say is way above the level of our knowledge as undergraduate students. Also, this option would take an absorbent amount of time to plan, design, and troubleshoot to get it to operate correctly. This option would involve programming a microchip to receive the proper format of the RFID number from the reader. This would also encompass designing an entire circuit which would be able to communicate wirelessly to our database to store the information from the RFID reader. Personally, there is absolutely no reason to build a device to try an accomplish such a simple task. To say the least we would not have enough time to accomplish this feat within the timeframe of senior design. With some more years of experience in design and implementation of micro-electronics then this could possibly have been done.

3.7.2.2 Arduino



Figure 29: Arduino

Moving onto the popular microcontroller line up, we have the well-known Arduino. The Arduino is a popular microcontroller because of how diverse it is when it comes to small scale projects such as our own and larger scale projects too. We have all seen or know of someone building something awesome using Arduino. There are also a ton of online resources and larger communities that are fully involved into development using Arduino. The major advantages of integrating Arduino into our project would be its usability, the many examples of open-source code on the internet, and once again it's large online community in case we need to contact someone for troubleshooting purposes. Although the Arduino has a lot of advantages it does have its short comings.

The disadvantages of integrating Arduino into our project would be the cost of the device, and surprisingly it maybe too simple to gain any understanding from. Due to its popularity in the microcontroller world the Arduino could be a lot pricier then it's other counterparts in this decision. A simple starter kit for the Arduino could range from \$15-\$40 and up. Not to mention any other module we would need to integrate in order to accomplish our main tasks. For a project as small as ours and being independently funded we would like to cut costs wherever necessary to mitigate and financial hardship on our team. Being undergraduate college student's money is an issue that must be met with improvisation and craftiness.

3.7.2.3 Raspberry Pi

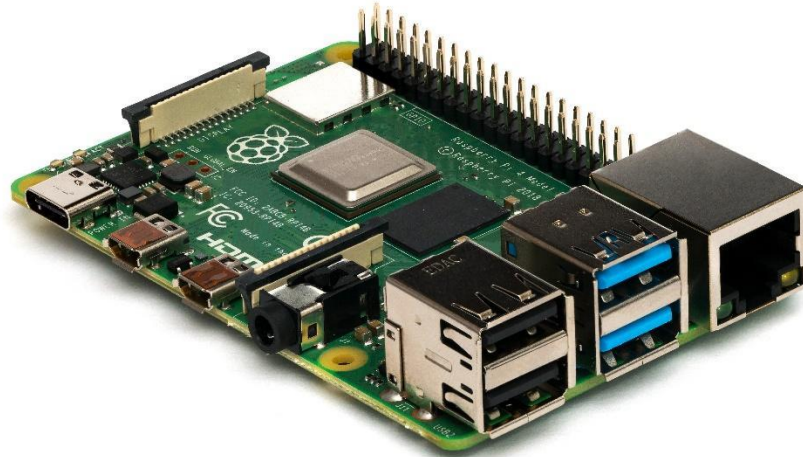

Figure 30: Raspberry Pi

The other disadvantage to Arduino is actually its simplicity. After looking into some of the functions that would be needed and also the reviews of other developers online. A consensus has been met that there is not much to learn when integrating an Arduino, because of how simple to use it is. By using an Arduino we would not get the education on the basics such as ADC, Serial communication, and I2C. The final verdict of the team was not to integrate Arduino into our project for the reasons I mentioned above and also the benefits that the other options provide our project.

Next is the famous Raspberry Pi. What makes the Raspberry Pi so appealing to our project is the fact that the Raspberry Pi is essentially just a computer. That means it is integrated with a Wi-Fi network module. With the Wi-Fi module already attached to the device we would not have to worry about delivering power to it as well as the device. Powering our project is very critical and it needs to be done as efficient as possible in order to mitigate any wasteful aspects to our project.

Additionally, having the Wi-Fi module already integrated it would make programming simpler since we don't have to write commands to it. Another huge advantage to the Raspberry Pi is that it is a Linux based machine. That being said we would have access to numerous programming languages such as C, C++,

Java, Python, and Ruby to name a few. The Raspberry Pi is a powerful device that could facilitate our project just like the Arduino with little to no issue, but just like the Arduino the Raspberry Pi has its own short comings.

The main issue is exactly like the Arduino. This device costs too much! A Raspberry Pi on average is anywhere from \$30-\$100 depending on what kind of kit you want. This price blows Arduino out of the water. This disadvantage is enough to turn our heads away from the Raspberry Pi. We can certainly accomplish our project for a lot less.

3.7.2.4 MSP430



Figure 31: MSP430

Lastly, the very well-studied MSP430 microcontroller. In the realm of microcontrollers, the MSP430 holds it own when compared to the others on the list. The MSP430 is a powerful cost-effective microcontroller with a ton of online support for developers. The main advantage of the MSP430 over the others is obviously it's cost but it also has other great edges that broke away from the Arduino and Raspberry Pi. As stated above one of the areas where the Arduino lacked was actually in it's simplicity and that undergraduates such as ourselves wouldn't be able to learn much from using an Arduino. The MSP430 provides us with enough challenge in understanding to gain some good knowledge of microcontrollers from its use. Things such as ADC, Serial communication, and I2C are all concepts that must be learned to perform well using MSP430 as a microcontroller. One of the greatest edges on the MSP430 is based on the simple fact that we actually know what we're using. During our time studying at University

of Central Florida as computer and electrical engineers the MSP430 came up quite often. In our introductory course of engineering EGN 3211 (Engineering Analysis and Computation) we got our first taste of what a microcontroller is and how to write a program on it. Albeit we were tasked to simply make lights blink, it primed our brains into the microcontroller world. In the more robust and rigorous course of engineering EEL 4742 (Embedded Systems) we got exposed to a deeper analysis of what goes on inside of the microcontrollers. Timers, interrupts, I2C, UART, and many other great topics were covered. The class was also paired with a laboratory component where we got to learn hands on how to program the MSP430 to do pretty amazing things such as creating interrupts to allow the microcontroller to pause when a button is clicked to do rapid calculations. Although the MSP430 is a perfect fit for our project, the final option happens to be the best in terms of usability.

3.7.2.5 Adafruit Feather Huzzah

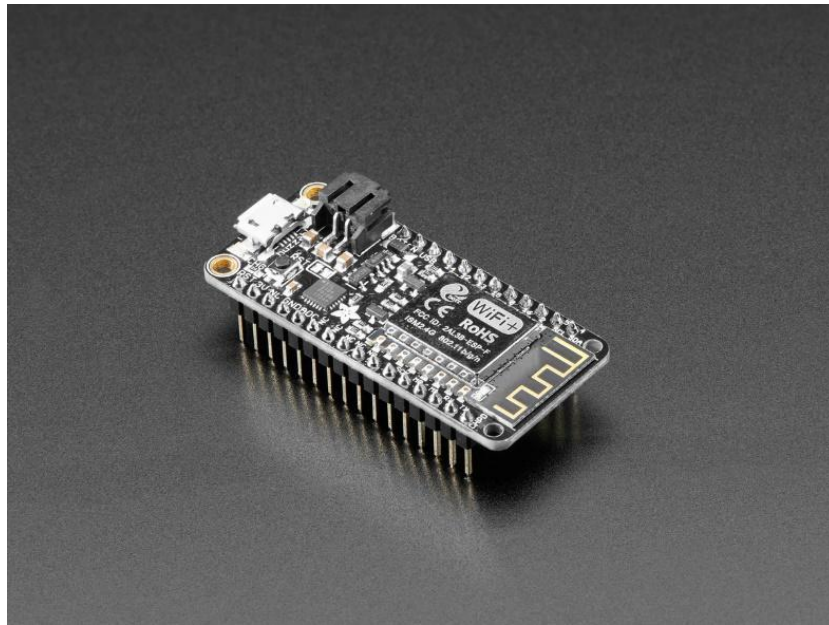

Figure 32: Adafruit Feather HUZAZH

Moving on to the Adafruit Feather HUZAZH, this tiny controller is packed with all the features we would need in order to interface with our RFID reader. It is very similar in regards of the other controllers, but there is one feature that completely pulls this option way ahead of its competitors. The Adafruit Feather HUZAZH is equipped with a ESP8266 Module Wi-Fi network module! This

information came to us recently that everything we absolutely need is right on the Adafruit Feather Huzzah. With this controller harnessing the power of using the internet, we will be able to write code to interface with our reader and also send POST requests to our database via Wi-Fi all in the same source code. The Adafruit Feather Huzzah is equipped with NodeMCU Lua in order to program the device which we will not need because you can flash the Arduino IDE onto the board. By using the Arduino IDE, we will be able to write C code for development. Being able to write code in C allows us to use the prior knowledge we have gained from EGN 3211 (Engineering Analysis and Computation) and also COP 3502C (Computer Science I) in order to correctly program the Adafruit Feather Huzzah to perform all of the necessary tasks needed for our personal wardrobe assistant. The best part about this device is that it is the cheapest of all of the controllers. Sitting at a whopping \$18.95 online, this price is well within our margins for the cost of the controller. Unfortunately for MSP430, this is our decision moving forward into our project. If the Adafruit Feather Huzzah turns out to be more complicated then we have calculated then our back up plan for microcontrollers are in the order as follows: MSP430, Arduino, Raspberry Pi. We already have some spare MSP430G2553's from our previous classes just in case we deem it necessary to switch to plan B.

3.7.3 Interfacing with ID-3LA RFID Reader Module

Our choice of RFID Reader is the ID-3LA Reader Module. Specifications for our choice are mentioned in previous sections. In this section I will only state what needs to be done to connect the ID-3LA to the Adafruit feather. It is a very simple process that involves the well-known topic of UART. When the tag comes within range of the antenna, there will be an electromagnetic force created from the interaction. This electromagnetic force is way above the topic for this section, you will just have to trust that an electromagnetic force is created. This force will trigger the reader to capture the information from the RFID tag and send the data to the microcontroller via UART pin 9. To transmit data via UART the reader and the microcontroller must be in synchronization. This means that both the reader and the microcontroller must have the baud rate or transmit the same number of bits per second. The default baud rate of the ID-3LA is 9600 bits per second which seems standard for modules such as this. Configuring the baud rate on the feather is a fairly simple process. It takes about one or two lines of code. The UART pin 9 from the ID-3LA will be connected to the RX pin on the feather; this function is distributed across a few selected pins. Pin 15 and Pin 7 may be used as UART Serial Receiver pins. The data sent to the feather will be 12 ASCII characters. The

first 10 being the RFID tag and the last two is the XOR of the previous 10 characters. Once the serial data is received it will be processed by the feather.

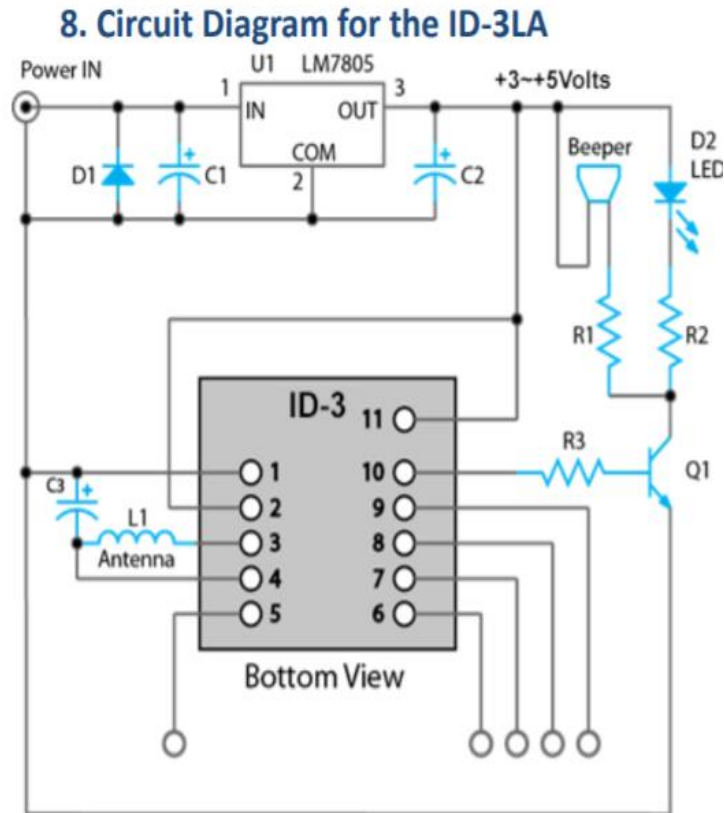

Figure 33: ID-3LA Schematic (Copyright permission granted)

3.7.4 Backup RFID Reader Module: EM18

Our backup reader is the EM18 Module. For this section's sake I will explain how the Adafruit Feather HUZAZH will interface with the EM18 Module. There will be details on configuration & baud rate of the two modules to sync. After looking into this process, I have found it to be quite simple in nature. Let's take a dive into this device.

The EM18 is a small device capable of reading RFID tag numbers and transmitting them to our controller. The operating voltage of the EM18 is between +4.5V to +5.5V. Supplying too much power to the EM18 could cause irreversible damage, So we must send power properly to the module via the controller. Essentially our power supply will power the microcontroller and the controller will distribute power to the reader.

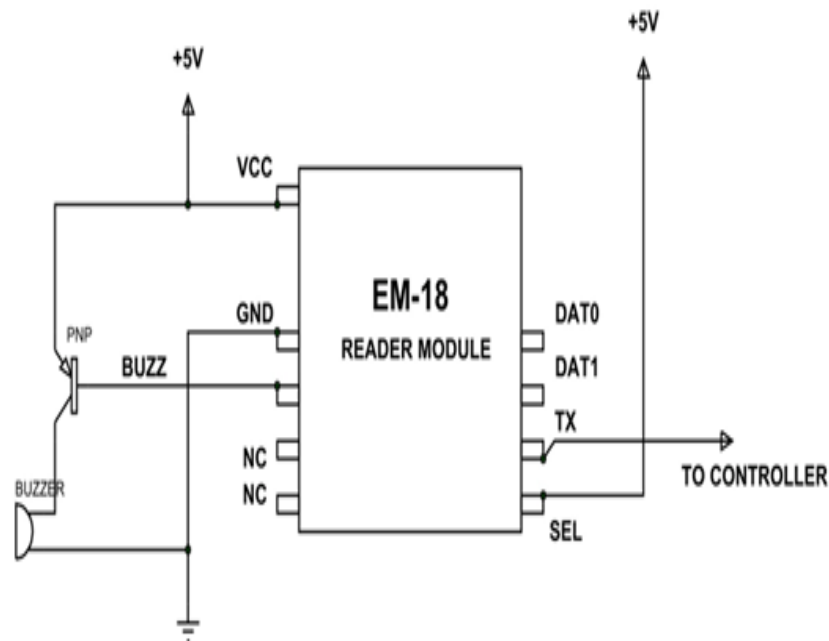

Figure 34: EM18 Schematic

As shown in the figure above we will have about 5V connected to VCC from the microcontroller. For the microcontroller to receive information from the EM18 it must be connected to the TX pin. To achieve synchronization between the reader and the microcontroller the baud rates must be set to 9600 bits per second. By default, the baud rate on the reader is already set to 9600 bits per second. To configure the baud rate for the microcontroller it's as simple as writing one line of code. If the baud rates of the EM18 or the controller are off by any means, then our system will not work correctly. The EM18 reader also comes with a buzzer, which we will be using full capability of. The buzzer will allow us to validate whether the reader was able to read the RFID tag, which in turn gives us better paths to troubleshoot our project. The entire run down of data from our antenna through the EM18 is as follows. RFID tag is brought near EM18. Electromagnetic force from the interaction of the EM18 and the RFID tag will cause the reader to read the RFID tag. The module reads the information and sends it to the controller via TX pin. The format of the RFID tag numbers is 12 ASCII characters. 10 ASCII characters represent the tag ID and two characters are the XOR of the previous 10 characters. After the information has been transmitted, the module will stop sending the data. The serial data received by the controller contains all the information and is prepared for processing. After this step the Adafruit will handle connecting to Wi-Fi and sending this data to our database.

3.7.6 Power Management

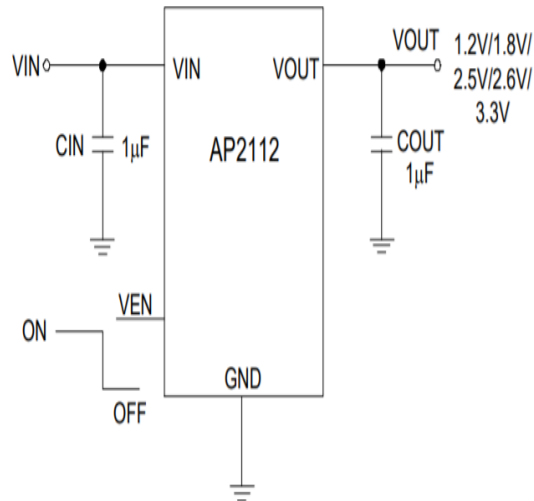

Figure 37: AP2112K schematic

The feather comes integrated with the AP2112K 3.3V regulator. If we decide to power the feather from the USB port, then the AP2112K will down regulate the 5V from the USB to 3.3V. We also have the option of running off a 3.7v LiPo battery. This option will allow us to be more portable and be able to recharge the battery life of the feather via the USB underneath their new feature called “Hotswap” which allows the feather to switch from charging on the USB to relying on power from the 3.7V LiPo battery. Our best option would be to design a power supply that has USB capabilities. This will allow us to maintain the AP2112K in use. It is specifically not recommended that we connect a power supply to the 3V and GND pins on the feather. This will disable the AP2112K voltage regulator and can cause damage to the board itself if we undergo a spike in current. Powering this board along with the EM18 and possibly an LCD screen will be one of the biggest challenges for our group. Due to the ESP8266 consuming 250mA of the 500mA output from the board’s regulator. We have little options when it comes to powering other devices from the feather. In the power management manual, it explicitly states that we should budget only 250mA, which gives the ESP8266 plenty of room to operate. This is a critical margin for this project because we do not want to cause damage to our controller by overheating it. In order to remain aligned with our best option we have decided to integrate a new module into our project. Since USB is our best bet, using a DC-DC USB charger module is a simple choice. By using this tiny module, we will be able to keep the robustness of having USB power capabilities which in turn allows us to remain using the AP2112K 3.3V regulator. This module will be mounted onto the PCB board along with the antenna, EM18, LCD screen and power supply.

Product introduction

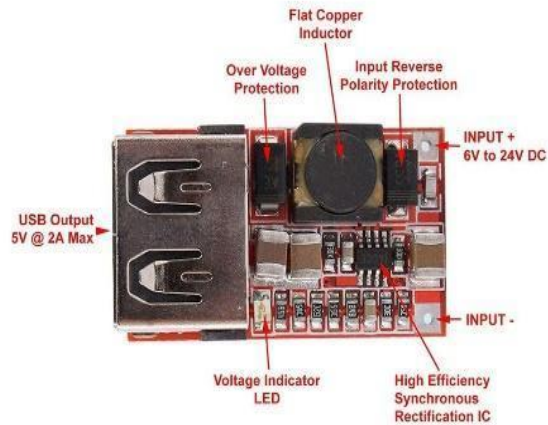

Figure 38: Example USB module DC-DC converter

3.7.7 USB to UART converter CP2104

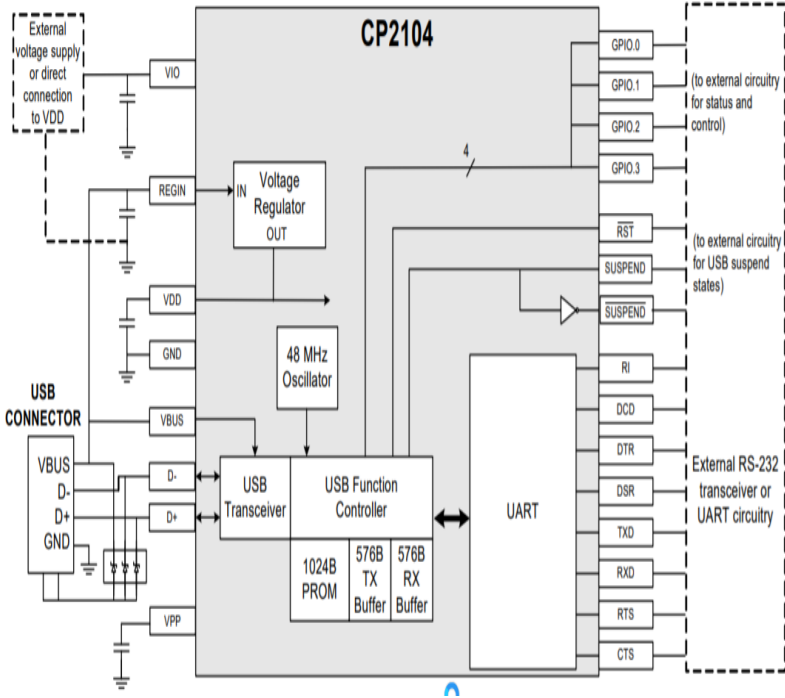

Figure 39: CP2104 Schematic

In order to communicate to the board and from the board to the ESP8266 Wi-Fi Module there is a critical component that we must discuss. This component is the USB – UART bridge. The Adafruit feather is integrated with the CP2104 onboard for our convenience when we need to deal with communication. In this section I will be describing the features of the pins off the CP2104 and which pins will be used to communicate.

Pin 6 (Vdd) is the power input for the CP2104 and to operate the tiny module it will require minimum 3V maximum 3.6V. Thankfully, this voltage will be supplied by the board and we will not have to worry about powering it ourselves. Pin 2 is Ground (GND). Pin 9 (RST) is the device reset. We can initiate a system reset on the module by driving this pin low for 15 microseconds. The two most important pins are 21 and 20 when needed for communication. Pin 21 (TXD) is the UART transmit which will allow us to transmit data from the feather. Pin 20 (RXD) is the UART receiver which will allow us to receive data and send it to the feather to be interpreted. These pins will be the most important when our feather is using the CP2104 module. The rest of the pins will aid the CP2104 in collecting the data synchronously with our reader. Lastly the baud rate must be set through our Arduino IDE to 9600 bits per second. This is the specified default baud rate of the EM18 reader.

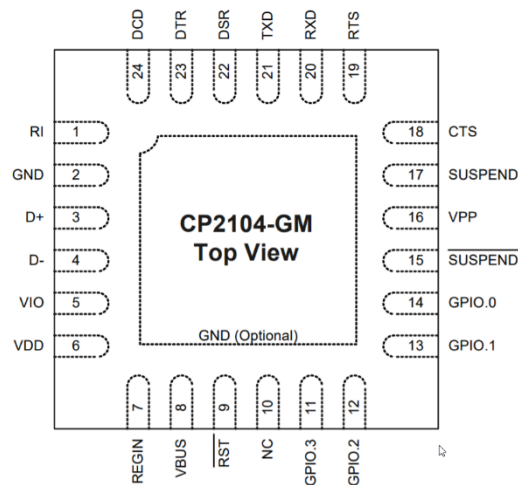

Figure 40: CP2104 Chip layout

3.7.8 The use of Wi-Fi in IoT

Wi-Fi was released for consumer use in 1997. From the day of its birth, Wi-Fi has increased in usability and decreased in how much it costs to use it. In the beginning speeds were only running at two megabytes per second, which is extremely slow relative to today's speeds. A quote from the company Purple describes Wi-Fi in its best terms. "At a base level, Wi-Fi is a way of getting

broadband internet to a device using wireless transmitters and radio signals. Once a transmitter receives data from the internet, it converts the data into a radio signal that can be received and read by Wi-Fi enabled devices. Information is then exchanged between the transmitter and the device.” (purple.ai) This exchange has gotten better and faster overtime as technology advances forward. As of today, there are certainly billions of devices that can connect to a Wi-Fi access point. Most of us cannot imagine a life without Wi-Fi. We use it for work, to run businesses, to buy and sell products, and for entertainment.

Wi-Fi uses electromagnetic waves to communicate, these waves are also called radio waves and they run at two main frequencies. 2.4 Gigahertz (802.11b) and 5 Gigahertz (802.11a). Over several years until today there have been plenty of revisions to the standards of Wi-Fi, but we have achieved speeds of Gigabytes per seconds. Since the conception of Wi-Fi and its revisions, more and more devices are able to send and receive information. This leads us to the term Internet of Things or (IoT). Which defines the abilities of interweaving several thousand devices and machines to communicate via Wi-Fi. Toasters, home security systems, light switches, and TVs to name just a few have all seen the benefits of IoT. Being able to connect to the internet wirelessly opens doors for literally every part in any home. Being able to take advantage of the IoT is where our personal wardrobe assistant truly shines and provides the user with lightning-fast response. Wi-Fi will continue to grow and as we move forward, we will certainly see more and more aspects of our human life undergo rapid change when it comes to IoT.

3.7.9 ESP8266 Wi-Fi Module

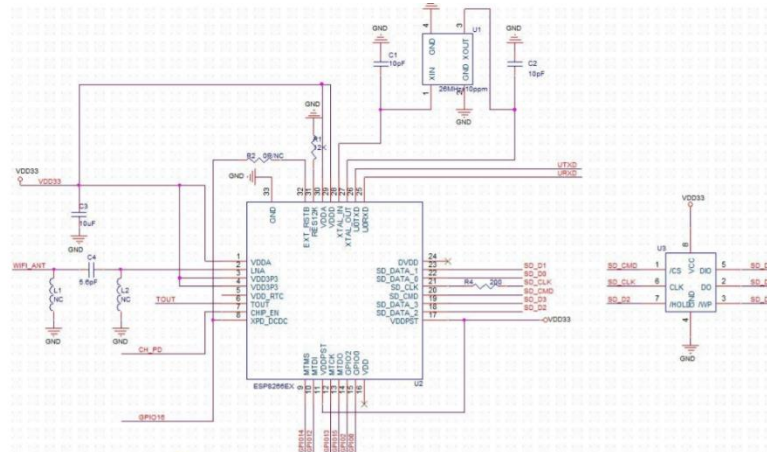

Figure 41: ESP8266 Schematic (Copyright permission pending)

In this section I will be discussing the grandiose of our option in choosing the Adafruit feather to manage the communications of our personal wardrobe

assistant. The Adafruit feather HUZAZH is integrated with the ESP8266 Wi-Fi network module. This little module packs a huge punch in what it offers our project. Some features of the ESP8266 include 802.11 b/g/n protocol, Wi-Fi Direct (PSP) soft-AP, Integrated TCP/IP protocol stack, Integrated power management system, and wake up transmissions of 2 milliseconds. The ESP8266 was specifically designed for mobile and wearable electronics for IoT applications. Its goal is to achieve the lowest power consumption possible. The power management architecture operates in 3 modes: active mode, sleep mode, and deep sleep mode. After using advanced power management techniques and logic to shutdown functions that are not needed the ESP8266 consumes less than 12 microamps in sleep mode and consumes less than 1 milliwatts. When the ESP8266 is in its sleep mode the real-time clock and watchdog remains active. The clock can be programmed to wake up the ESP8266 at any interval or when a specified condition is met. This is very important when it comes to the RFID tags and the amount of time in between each scan. This will allow us to keep the power consumption of the power supply extremely low.

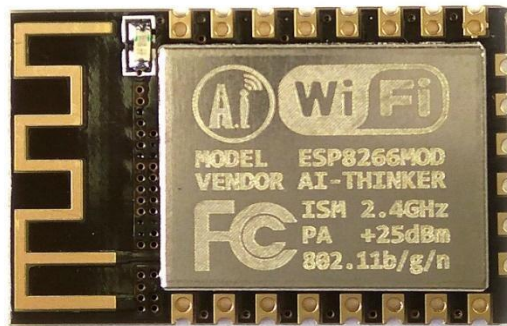

Figure 42: ESP8266 chip

The ESP8266 is embedded with an ultra-low power Micro 32-bit CPU with a 16-bit thumb mode. The memory controller contains ROM, and SRAM. There are up to 16 GPIO pins. These pins are multiplexed with other functions such as host interface, UART, SI, and Bluetooth. The application and firmware is executed in on-chip ROM and SRAM, which loads the instructions. All in all the ESP8266 is the powerhouse that will allow us to achieve capabilities of Wi-Fi seamlessly from our Adafruit feather. Without the ESP8266 embedded onto the feather we would have needed to find a separate Wi-Fi Module and integrate it into our project, which would have included distributing power fairly. Now that all of that is in one device

there's no need to worry about power consumption of the module. The feather takes care of that for us easily.

To connect to a Wi-Fi network is very simple. All it takes is a few programming commands. The Adafruit feathers standard IDE is Node MCU. This is a brand-new IDE to each of us in the group but fear not. The Adafruit feather is also capable of using the Arduino IDE, which as I covered in a previous section has a ton of online resources for us to claw through to figure how to use it to program the Adafruit feather.

Using a stand alone WiFi Module

Our next design will be excluding the microcontroller and including a stand alone WiFi Module. By integrating a stand alone wifi module we will be able to operate our system on less power and save space on our PCB. There are dozens upon dozens of WiFi modules on the market today. After some online research and observing other similar applications, we decided to go with the ESP-01s WiFi Module. By using the ESP-01s we still have the capability of using Arduino IDE to program the module, and we also have the capability of UART connection. The ESP-01s is a tiny WiFi Module at a cost of about \$5 for a pack of 5 or 6. So as for cost, it fits comfortably into our budget.

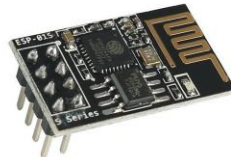

3.7.10 Using Arduino IDE

As stated above the Arduino IDE can be flashed to the feather and used for development. In this section I will go through the steps to get the Arduino IDE onto the feather and what kind of commands we will need in order to operate our personal wardrobe assistant. I will be specifically detailing steps for using Windows OS. If instructions for MAC OS is needed then please refer to the references page.

First off, to upload code to the ESP8266 you will require any data-capable micro-USB cable. Connect the micro-USB cable to the feather and to your computer's port. Before beginning the SiLabs CP2104 Driver must be downloaded. Please refer to the references for the website link for using Arduino IDE to find

drivers and other resources mentioned further. Install the Arduino IDE 1.6.8 or later. Open Arduino IDE, to install the ESP8266 Board Package, go to preferences and in “Additional Boards Manager URLs” enter http://arduino.esp8266.com/stable/package_esp8266com_index.json into the field. Afterward go to the board manager and scroll down to “esp8266 by ESP8266 Community” and install.

To configure the ESP8266 go to tools, then go to board and click on Adafruit Feather Huzzah ESP8266. Keep the flash size at “4M (3M SPIFFS)”. For the upload speed as I mentioned in previous sections will be set to the default baud rate of the EM18, 9600 bits per second. Go to port and match the COM port for the USB serial cable. This can be found by going to devices on your machine and finding the USB device. At this point we are now ready to use the Arduino IDE with our Adafruit feather Huzzah.

3.7.11 Connecting ESP8266 to Wi-Fi

The reason why we chose to use the Adafruit feather is because of how easy it is to connect to Wi-Fi and a web server. Majority of microcontrollers do not come preinstalled with a Wi-Fi module. So to connect to Wi-Fi we would need an extra. Before writing any code into Arduino IDE it is important that we include “<ESP8266WiFi.h>” which is the standard library for operating the ESP8266 properly. Create two strings, one for the network SSID and one for the network’s password. This will be used to locate the access point and connect to it. Create another screen for the name of the host server. Within a setup function we start by calling the function “Serial.begin()” and inside of the parenthesis add the baud rate in which we would like to communicate to the server as. Afterward we call the “WiFi.begin()” function and pass in both the SSID and the password in that order separated by a comma. We must use the WiFi Client class to create TCP connections with our feather and the webserver, create a client of type WiFi Client. We can create a while loop and use logic to detect whether the feather has connected to the access point. Create a URL for the specific request and place that into a string. We will be using the standard port 80 for connections, creating an integer representing HTTP Port 80. “client.connect (host, HTTP Port)” is a function that will return a Boolean. It will return true if the connection has been made, false if otherwise. This next step will allow us to send POST requests to the web server. By using the function “client.print()” and building the request “GET + URL + HTTP/1.1\r\n + host + \r\n” (this is an example). We can send POST requests to the web server.

3.7.12 Back up for Adafruit feather : MSP430

If the Adafruit feather does not work out in our favor, then the backup microcontroller we will utilize will be the MSP430. Among all the controllers stated above excluding the feather, the MSP430 is the most familiar device we have all worked with at some point in time in our academic careers. Since we all were introduced to microcontrollers through the MSP430 we each have one on hand ready in case the feather needs a substitute. Since the MSP430 does not come installed with a Wi-Fi module then we will have to acquire a standalone Wi-Fi module and use the MSP430 to power and program it to communicate with our database.

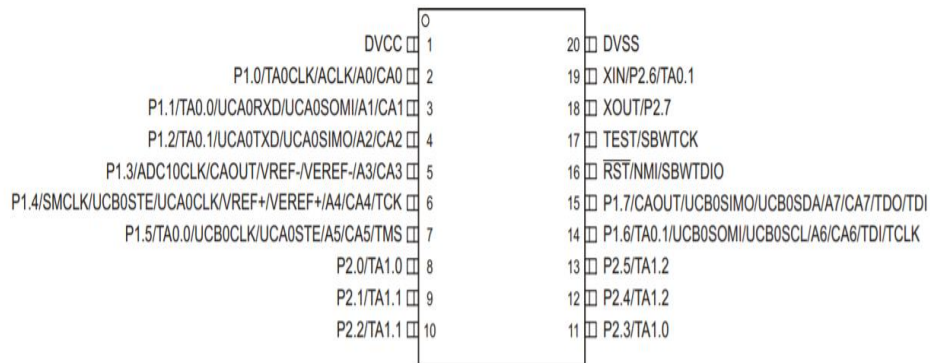

Figure 43: MSP430 layout

To communicate to the RFID tag reader, we must use the UART TXD and RXD pins from the MSP430. These pins are P1.1 and P1.2 respectively. The baud rate must also be set to 9600 bits per second as the default baud rate of the reader is set.

The proper stand-alone Wi-Fi module that would be used is the ESP-01. This module we give the MSP430 the power of Wi-Fi. For the MSP430 to communicate with the ESP-01 there will first be power distributed to from the MSP430. 3.3V to be exact. The ESP-01 also has a TX and a RX in order to communicate to the MSP430. Aside from the pins P1.1 and P1.2 the MSP430 can also communicate via UART using pre installed jumpers on the board.

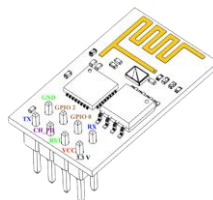

Figure 44: ESP-01 Graphic

3.7.13 Choosing a method for user to interact with device

The microcontroller itself will be running code in order to connect to the internet and send information. Presuming that a user will need to first connect to their own Wi-Fi access point we must have a way to give the user control to configure the device and connect to whatever Wi-Fi access point they desire. There are several ways a user can interface with our system. Through touch screen, a controller, or just some buttons and an LCD. Although using a touch screen would be aesthetically pleasing, it would be over killing for our application and programming a touch screen might be over our heads. Using an actual controller of some sort would also be an overkill. We don't need an interface with analog input or several different buttons. By default, a simple 16x2 LCD screen and a few buttons to navigate should suffice. With our design we have chosen the LGDehome IIC/I2C/TWI LCD 16x2 Serial interface. This LCD screen was chosen due to its small size, low cost, and adapter module for easy access to complete the I2C circuit for communication. The buttons are Gikfun TACT Switch push buttons, they are also simple, low cost and light weight.

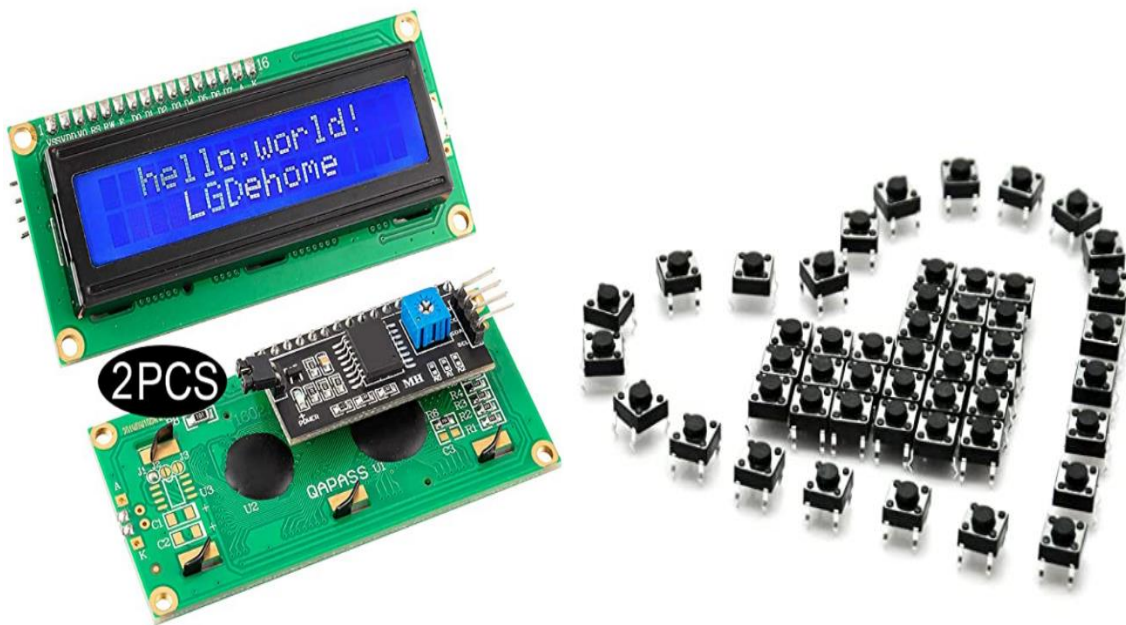

Figure 45 & 46: 16x2 LCD screen and buttons

3.8 Web Application

A web application is a piece of software that runs on a web server, instead of running locally on a user's operating system. They are accessed by the user through a web server and require an active network connection to work properly. At its most basic form it consists of a front end (client side) and an API (back end) to work with the server and perform actions. Using a web application reduces the problem of version control as all users will have access to only a single version. Lastly, unlike most OS applications the applications require a specific operation system and having multiple operating systems makes operating system applications not as scalable. Last the application does not take any space and makes it easier for user who are limited by their computer memory.

3.8.1 Stacks

A web stack is a collection of software that allows for web development, it usually contains an operating system, database, and a web server.

1. LAMP

1. Linux
2. Apache - Web Server
3. MySQL - Database
4. PHP - Scripting Language

2. MEAN, MERN, MEVN

All three have 3 common compounds except for the frontend framework.

1. MONGODB - document Database
2. Express - NodeJS web framework
3. NodeJS - JavaScript Server/ Runtime Environment
4. Front End Framework

a. MEAN

Angular: Front end web framework maintained by google

b. MEVN

Vue:

c. MERN

React: JavaScript library for building UI maintained by Facebook

We will explain why we ended up choosing a MERN stack, but it was mainly due to familiarity. We quickly moved on from a LAMP stack once we found the

difference in performance between NODE vs APACHE, and SQL vs NOSQL Database.

3.8.2 Databases

There are two different types of databases we could have used for our project, either a SQL (Structured Query Language) or NoSQL (None - Structured Query Language). There are many different types of databases, but the latter are the ones our group is familiar with.



Figure 47: Multiple different databases based on the SQL and NoSQL Structure.

3.8.2.1 SQL

SQL is used in programming and designed for managing data that is held in a relational database management system (RDBMS¹). It is mainly used to handle structured data, data that is related to each other. It is very rigid with a storage model that contains various tables with fixed rows and columns. SQL databases are vertically scalable, which means that you can increase the load on a single server by increasing the capacity and effectiveness of its components. At last, SQL databases support ACID transactions.

¹ RDBMS is a software that allows the user to create, maintain, define, and control access to a database.

- a. Atomicity: Guarantees that different transactions² are treated in a way where they are either successful or unsuccessful. If any part of a transaction fails, then the entire transaction is deemed unsuccessful, and no part of the database is changed.
- b. Consistency: Ensures that only valid data is stored in the database, prevents database corruption and guarantees primary to foreign key relationships.
- c. Isolation: Maintains that different transactions do not affect each other. Ensures that concurrent transactions are treated as if they were made sequentially.
- d. Durability: Even through system failures it guarantees that once a transaction stays committed.

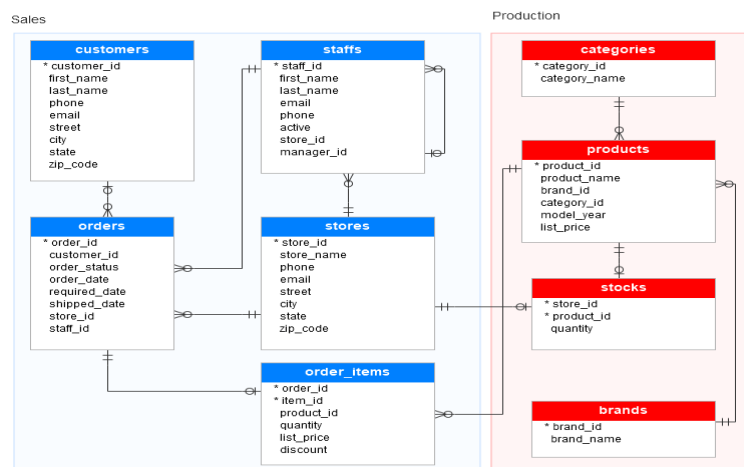

Figure 48: Sample of a SQL Database

The * represents both foreign and primary keys that relate multiple tables to each other. For example, you know the brand name of a product from the products table by having the brand_id and relating it to the brands table.

3.8.2.2 NOSQL

² Transactions represent any change in the database.

NoSQL databases prioritize availability, partition tolerance and speed. It does this by sacrificing ACID Transactions³, lack of the ability to combine columns from one or more tables in a database (Join clause), and relations between tables. Instead of storing data in tables NoSQL databases use JSON⁴ documents in either key-value pairs, rows with dynamic columns and graphs. Typically, NoSQL databases use flexible data models, which allows you to easily make changes depending on your requirements and unforeseen events. NoSQL databases scale horizontally instead of vertically which means instead of upgrading your components you can have multiple cheap servers as needed. Most importantly the query times are significantly faster in comparison to a SQL database. This is due to the fact that data stored in a NoSQL database is optimized for queries unlike SQL where queries are required to be joined from multiple tables. The larger the tables the more expensive those joins become, the slower the query becomes. The motto being data that is accessed together should be stored together.

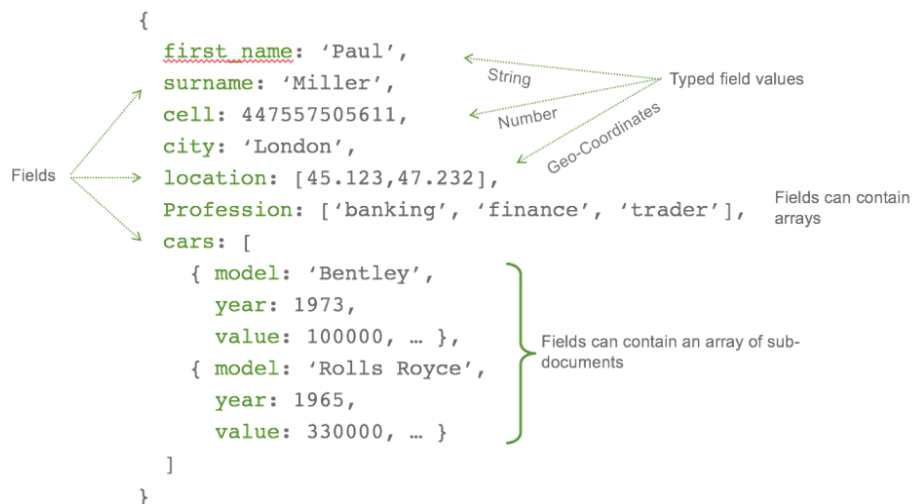

Figure 49: Sample Schema of a NoSQL database

Instead of using foreign and primary keys, the data is stored together where cars, and professions would represent a different table in a SQL database.

- a. Consistency: All clients see the same data, if an action is taken in a specific node all other nodes need to be updated.
- b. Availability: All nodes return a response regardless of if any nodes are down or not.

³ MongoDB is a type of NoSQL that does support ACID Transactions

⁴ JavaScript Object Notation is a file format used to interchange data

- c. Partition Tolerance: The node clusters need to continue despite communication breakdowns.

We choose to go with MongoDB, a NoSQL database mainly due to how much faster the queries are compared to a SQL database and its flexibility when it comes to making changes to the database. The scaling does not really apply to this project as we do not plan on commercializing the project and plan on having a small number of users. Additionally, we are also using mongoose, an object data modeling (ODM) library for MongoDB. Mongoose provides us with validation, simple queries, and allows us to have fast development. It is an intermediate between MongoDB and the server.

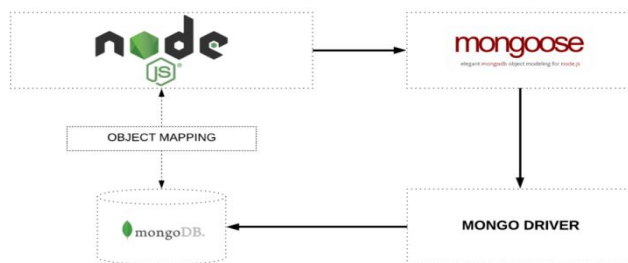

Figure 50: Sample Schema of a NoSQL database

3.8.2.3 Database Model

Without the ability to have foreign keys we had to have arrays that act as relations on a SQL database. Each user has their own security, wardrobe, and email array. The ID field is automatically generated by mongo when a new record is added. In security the hashing for the password will be done twice once leaving the user end and once again when arriving at the server. In wardrobe data number of articles, shirts, and pants will be calculated when an update to the table occurs. This will also occur in the article data table in the times used field.

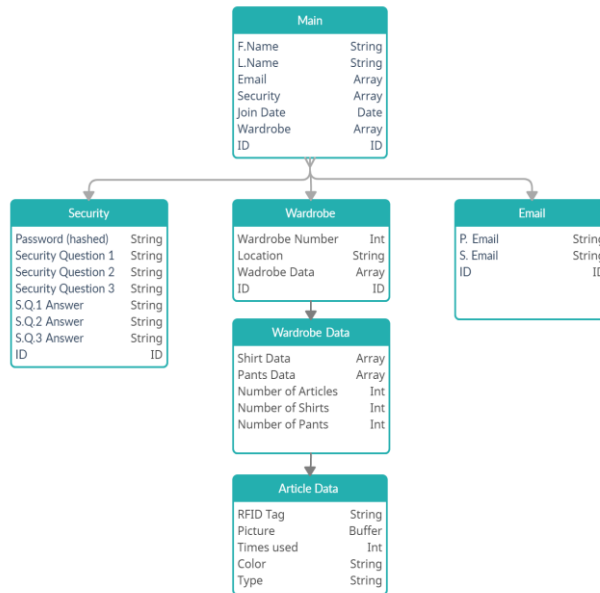

Figure 51: Database Model for the WebApp

Table 10: SQL VS NoSQL

	SQL	NoSQL
Storage Model	Tables with fixed rows and columns	JSON Documents
Schemas	Rigid and not Flexible	Dynamic and Flexible
Scaling	Vertical (Larger primary server)	Horizontal (Multiple servers)
Properties	ACID	CAP
Table Joins	Commonly used	Almost never used

3.8.3 Backend Frameworks

Frameworks allow us to organize our web application on the server side by handling routes, handling requests (Post, Get, Put) among other things. Examples such as Express, Hapi, Koa, and Fastify.

3.8.3.1 Fastify

Fastify highly focuses on speed and responsiveness with the possibility of dealing with thirty thousand requests per second. It has a wide array of support from different plugins and its schema based just like our database. Fastify supports asynchronous functions out of the box. Asynchronous functions are important because they allow multiple things to happen at the same time and prevents many errors that are related to latency. For example, requesting an image to be downloaded and the following line needs the image to perform and actions. If the functions were synchronous there will be an error since the image cannot be downloaded immediately. We instead have to wait for the image to download and then perform the actions, this is where asynchronous functions come into play. Additionally, Fastify automatically parses incoming requests into JavaScript Object Notation⁵ (JSON) if suggested and sends errors if the parsing was unable to be completed. At the end of the day, the main advantage of Fastify when comparing to other frameworks its speed and low overhead.

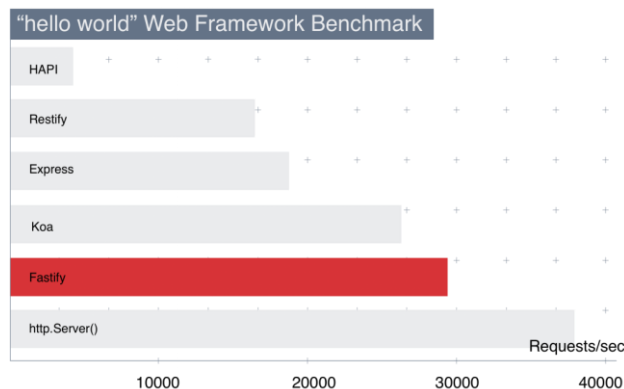

Figure 52: Request per second of multiple frameworks

3.8.3.2 Express

Express is a framework that works natively with NodeJS. Express is widely used and has a lot of documentation behind it. Support for asynchronous functions is present, however, unlike Fastify, it does not automatically parse incoming requests into JSON if suggested. In many ways Fastify is better than express, yet we choose to go with express due to experience, familiarity, and vastly more documentation than Fastify.

Table 11: Fastify & Express

⁵ JSON is a file format that is used for data interchange.

	Fastify	Express
Speed	One of the fastest web frameworks out there	Moderate Speed in comparison
User Base	Due to it being younger than express there is smaller user base	Strong user base with plenty of documentation

3.8.4 Runtime Environment

There are a couple of alternatives to NodeJS, such as Elixir and ASP.NET. I will discuss them to an extent, but at the end of the day the stack revolves around Node.js, npm, and a REST API.

1. NPM: Package manager for JavaScript that contains a multitude of code packages. Manages dependencies, conflicts, updates, and aids with installation.
2. API: Application interface, allows the different aspects, server side and client side, to work and talk to each other.
3. REST: Representational State Transfer, set of constraints that allow interactions with RESTful web services. REST APIs are usually fast, lightweight, and easily scalable.

Some important requirements for a RESTful API:

1. Client information is not store when invoking a get request.
2. Cacheable Data
3. Request are managed through HTTP.

3.8.4.1 Elixir

If we are talking about Elixir we must talk about Erlang. Erlang has real-time data processing which suits applications that want to have messaging services. This would be a nice aspect to have in our project as having real time updates would be beneficial. Elixir allows for both vertical and horizontal scaling. The scaling is a feature we will care about if we plan to expand the project to a commercial level. However, both features are not necessary; we do need fast update times but not necessarily real time.

3.8.4.2 ASP.NET

Aside from the fact that the primary language is C sharp, it is a synchronous model that is much simpler to maintain and update. It comes with more features out of the box than NodeJS, but it does have a more difficult time when it comes to integrating third-party libraries. If we were to pick ASP, the main reason would be the ability to use C# instead of JavaScript. ASP in theory is faster but it's very bloated in comparison to Node.

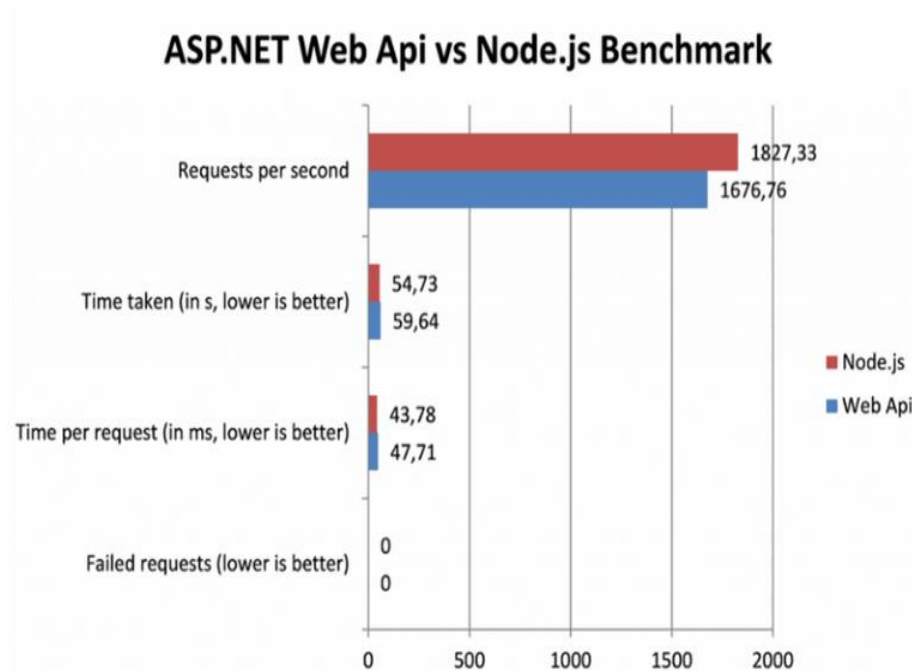

Figure 53: ASP and Node benchmark comparisons

3.8.4.3 NodeJS

NodeJS allows us to easily build server-side scalable applications. All libraries in NodeJS are asynchronous, as explained above it does not have to wait for an API to return data. It can handle a lot more requests per second in comparison to ASP and Elixir. It is thought of as synonymous to express. It is also very easy to scale applications that are built on Node, granted this does not really apply to our project. It serves both server-side and client-side making it a full-stack development option. Most importantly the support for the community is massive which can help resolve unforeseen problems in development.

Table 12 Comparison between Elixir & Nodejs & ASP

	NodeJS	ASP.NET
Language	Java Script	C#
Libraries	Library integration is simple, but less features out of the box	Library integration is difficult, but a lot of features out of the box
Customizable	Extremely customizable	Harder to customize due to the library integration.
Instructions	asynchronous	synchronous
Performance	Slower but lightness makes up for it	Faster but bloated

3.8.5 Server (reverse proxy)

It is typically good practice to pair NodeJS with either APACHE or NGINX as reverse proxies to fix vulnerabilities and improve NodeJS performance. Apache and NGINX are not the same as NodeJS. NodeJS is a runtime environment and Apache, and NGINX are servers. Granted NodeJS is regularly used to create web servers and does not need to be paired up with either APACHE or NGINX. A reverse proxy server directs client requests to the backend server, and NodeJS server in this case. Reverse proxy servers provide additional security, provide better traffic flow between the client and the server thus improving performance.

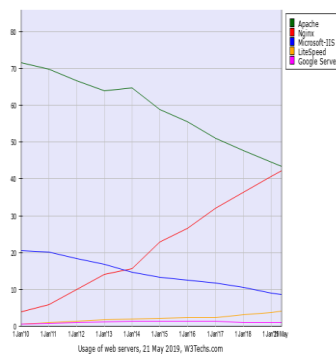

Figure 54: Server market share over 10 years.

3.8.5.1 APACHE

Typically, you will use PHP⁶ when using an apache server but there are variations that use Perl and Python. Apache is thread-based language each request is handled separately meaning if one request where to fail then the other request will not be impacted. Native support for static and dynamic content. Can operate in the filesystem or use URI to handle requests but prefers to use the filesystem. Lastly APACHE dynamically loads, and unloads modules allowing to add and remove features at will.

3.8.5.2 NGINX

NGINX was used mostly as a reverse proxy that worked in tandem with APACHE. Performance wise NGINX is more efficient and faster than Apache. Unlike Apache where you can simply remove modules at will without causing much of a headache, NGINX is the complete opposite. Modules need to be enabled

⁶ PHP a scripting language suited for web development.

when the server is being built and adding modules post-installation is not a simple task.

Table 13: NGINX VS APACHE

	NGINX	APACHE
Caching	Natively uses Fast CGI caching	Module cache module or Varnish http accelerator.
Handling Request	It uses an asynchronous, non-blocking architecture.	Process request using Multi-Processing-Modules

1. Caching: Store's data in such a way that it can be accessed faster later. This is an important feature that allows the user to experience the application in a faster more responsive manner. The following performance marks were gathered using Apache Bench on WordPress websites.

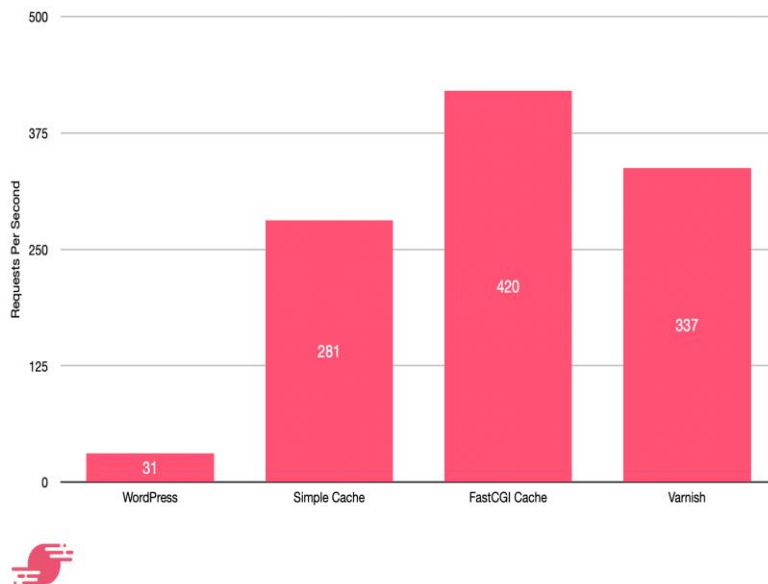

Figure 55: Request per second for multiple cache solutions

Figure 55 shows how much faster the FastCGI cache is when compared to its competitors. Allowing for 420 request per second, the closest competitor is Varnish coming in at 337 request per second. Essentially making any competitor to FastCGI 24% slower or more.

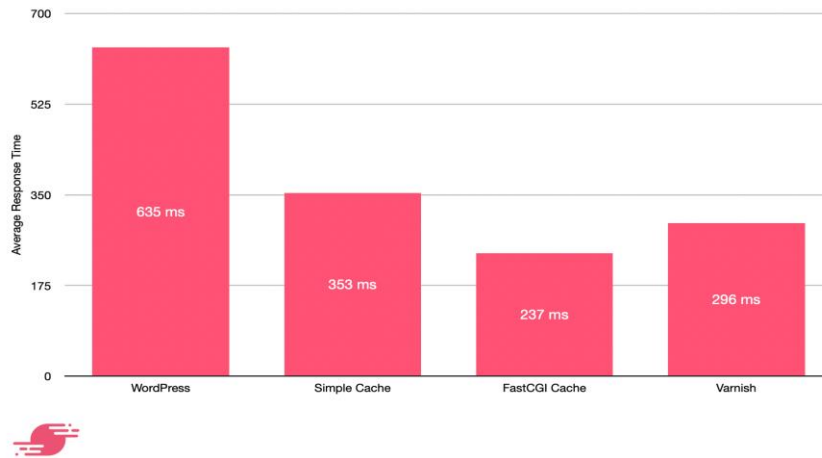

Figure 56: Average Response time for multiple cache solutions

2. Handling Request: APACHE uses threads for every connection to the server, with multiple users on the server this can become a taxing and expensive process. Take for example opening multiple applications on your computer. It is not usually an instant process, now imagine that for a website that would like to be fast and responsive. On the other hand, NGINX uses one process per CPU core where each core can handle a great number of connections without becoming as expensive as APACHE.

3.8.6 Client Side

When we mention the client side we like to talk about the frameworks, we refer to the different possibilities to achieve the same result. In this case each of the following frameworks can achieve the same result but each having their own unique characteristics. React uses the functional component model, Vue uses class based-templating, and Angular uses services and controlled models.



Figure 57: React vs Vue vs Angular

3.8.6.1 Vue

Vue is the newest framework of the bunch. It has the highest level of customizability which makes it the easier one to learn out of the three. Due to its simplicity and flexibility, it can lead to poorly written code that can make it difficult to debug. It is growing in popularity fast, which makes its infancy not a problem. As the development cycle gets closer to starting there is a chance that the application will be writing in Vue and not react but that has yet to be determined.

3.8.6.2 Angular

Angular components are called directives, directives are markers for different DOM (Document Object Model) which the developer can attach specific behaviors to. UI attributes are HTML (Hypertext Markup Language) and JavaScript for the tag's behavior. Angular is considered the hardest language when comparing it to the other two. You are required to learn concepts such as TypeScript and Model-view-Controller. It is the most mature framework, and it is considered a complete solution for the front end. Some of the features that is has overreact or Vue is that it uses TypeScript, it supports for developing dynamic web apps is spectacular. Most of our data and user interface is going to be dynamic by natures since the database is being updated when ever the user adds or removes an article of clothing from the wardrobe. Lastly, Angular provides testing and debugging in house with a single tool. React and Vue require third party tools to perform this type of testing.

3.8.6.3 React

React combines the UI and behavior components. The same part of codes will both create and display the UI element as well and state how that specific component is meant to behave. It is not as complete as angular and third-party libraries are usually needed. The most important thing is that like Vue, there is vast

support and problems that have been solved by the community. There will always be an answer to what you are trying to develop. As mentioned, before it was hard to decided between React and Vue. Angular was never truly in consideration as none of us know have ever used TypeScript, and since we plan on using multiple libraries. Angular would be useful when it comes to creating the dynamic tables and forms that we need to display the users wardrobe information, but this can we simulated by React libraries and should not be a significant setback that would force us to chance too Angular.

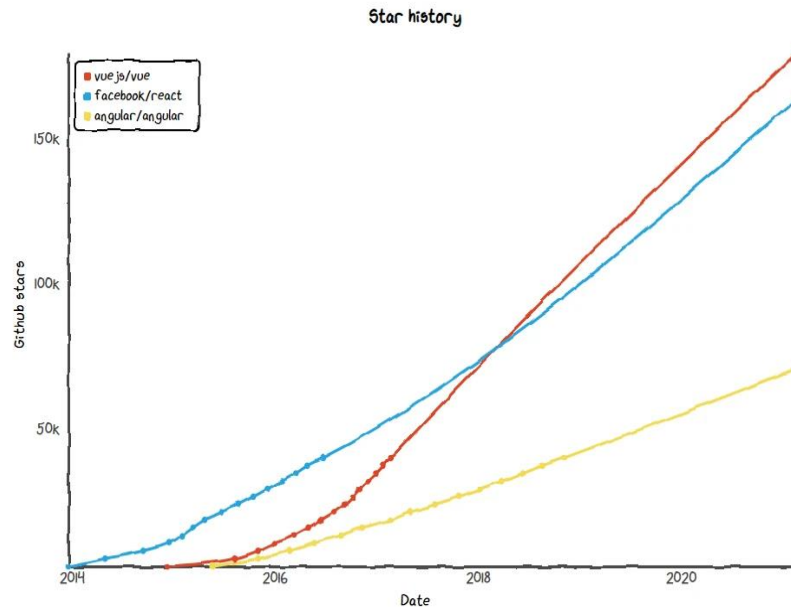

Figure 58: Popularity Vue vs React vs Angular

Table 14: Comparison between Vue & React & Angular

	Vue	React	Angular
Developed	Private	Facebook	Google
Features (no libraries)	In-between	Least number of native features	Most number of features
UI and Behavior	Combined in code	Combined in code	Separated in code

Maturity	Newest Language	Second Oldest Language	Most mature language
Community	Vast	Vast	Moderate
Difficulty	Simple	Simple	Steep learning curve

3.8.7 CSS

Cascading Style Sheet (CSS) is a language used to describe how the presentation (aesthetic) of the html is going to look like.

3.8.7.1 Bootstrap and Material-UI

Bootstrap is a front-end style framework that focuses on reactivity and mobile platforms. It contains pre-determined classes that aim to aid and assist with the User interface on applications. It contains both CSS and JavaScript properties. It provides SASS variables, a responsive grid, and JavaScript plugins. It allows developers who are not as creative, make aesthetic and responsive user interfaces. Classes contain the same properties and make the web application look tight and connected. The pre-build classes range from tables, forms, navigation bars, and picture slides.

Material-UI is another front end framework that assists in the development of front-end applications. It contains elements such as typography, box, grid, button, and many more. They are enhanced html elements that use props to interchange different styles. This circumvents all CSS and facilitates development.

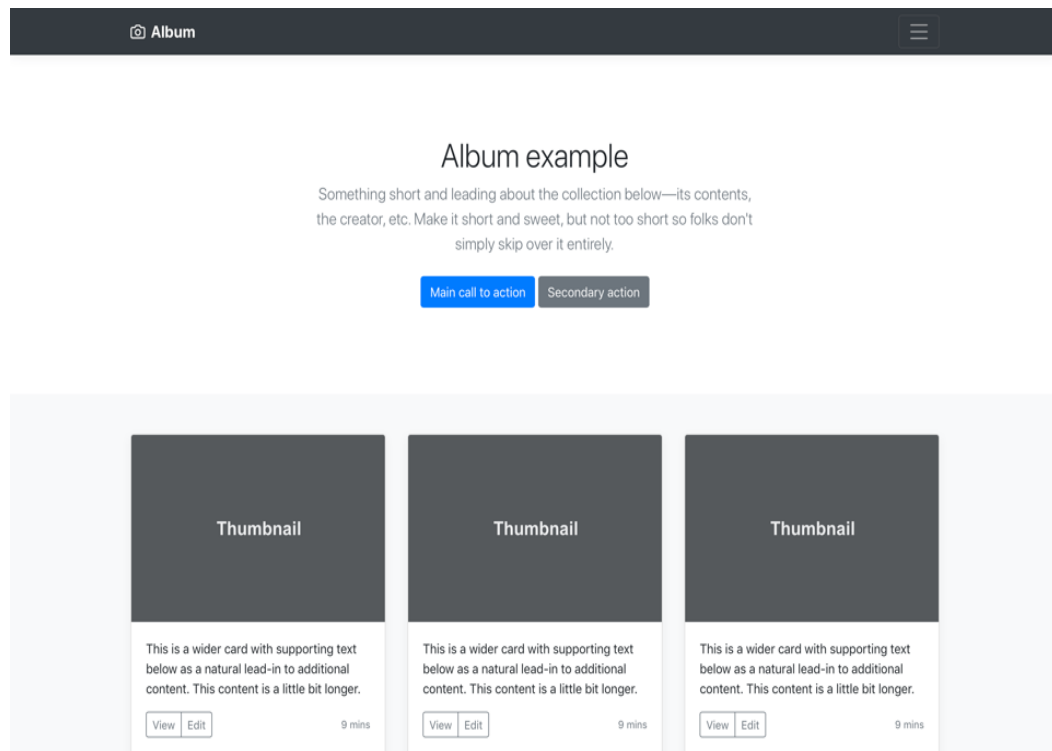

Figure 59: Sample Bootstrap 4

3.8. Testing

In this section we talk about what applications we are going to be using to test the endpoints. Simultaneously, we will also mention how we are testing the database. As we are testing the endpoints and databases with postman, we are going to be able to see what is happening to the database with Robo3t/Studio3t a Graphical User Interface that interacts with Mongo DB hosting developments.

3.8.8.1 Postman

Postman is a Graphical User Interface that allows the developer to test RESTful APIs. It allows you to perform HTML requests without having to write blocks of code. Instead of having to write a whole new route and function to perform the specific test we simply input the specific route we want to test, select the specific request we need GET or POST, and send a JSON file. The server's response is then sent in a JSON file from the server with ever status code 200 or any other corresponding code from the server.

Some alternatives are advance Rest Client (ARC), Paw, and the Insomnia REST Client. Insomnia being superior tot postman in many ways with it being lightweight and having a cleaner interface but there are some features that you do have to pay for.

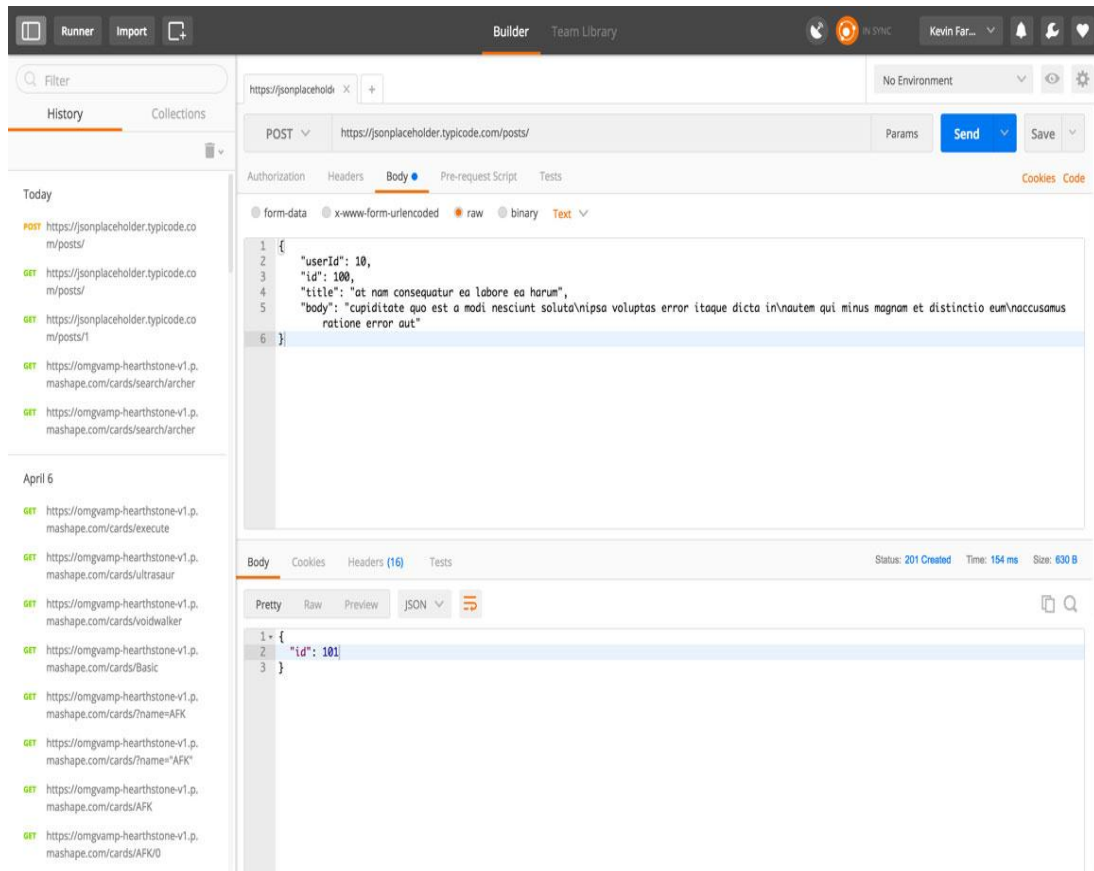

Figure 60: Sample Get Request on Postman

3.8.8.2 Robo3t (Robomongo)

Robo3t is a Graphical User Interface that enables developers to interact with the MongoDB platform. It shows real time updates to the database and lets you directly interact with the data present. You can perform all CRUD operation from the application or see those operations being performed by for example Postman.

There are other applications that perform a similar function such as NOSQL Booster, NOSQL Manager, Mongo Management Studia, MongoDB Compass, and

directly seeing the database on MongoDB Atlas. Ultimately, we went with Robo3t due to familiarity but the most used one is MongoDB Compass.

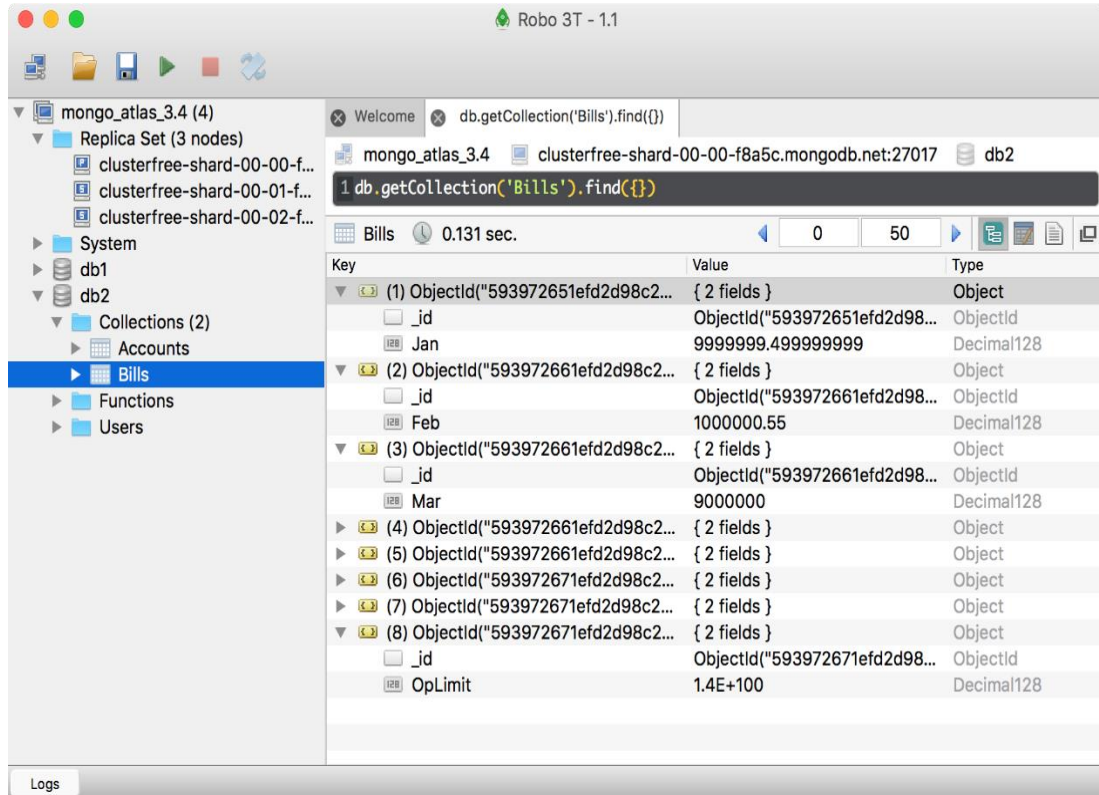

Figure 61: Robo3t Interface

3.8.8.3 Mocha

Mocha is a test framework that is part of NodeJS, its primary purpose is to make unit testing simple and approachable. Mocha executes functions and logs its results. This allows the developer to test to see if the functions that are being implement work as intended. The test cases run independently of each other, meaning that multiple tests to not interact with each other thus reducing the chance of having false positives. Mocha is a BDD tool, Behavior-driven development, and as stated earlier it allows developers to develop software that is predictable, reliable, and resilient to changes.

```
Terminal - bash - 90x24
bash
λ mocha (master): make test

duration:
  when slow
    ✓ should highlight in red (180ms)
  when reasonable
    ✓ should highlight in yellow (31ms)
  when fast
    ✓ should highlight in green

✓ 3 tests complete (242ms)

λ mocha (master):
```

Figure 62: Mocha Testing

3.8.9 Hosting

When it came to hosting, we had multiple options, we first thought of hosting the server and database on one of my personal machines. The reason being it is free, apart from the domain name, and I have full control of what the server is doing. Since we are in 2021 and there are plenty of options that more reliable, simpler, and less of a hassle we decided to just use hosting services.

3.8.9.1 Database Hosting

To host the database, we decided to use MongoDB Atlas a cloud-based database hosting service. It was created by the same developers who designed and engineered MongoDB. MongoDB atlas deals with most of the overhead when it comes to hosting your database. Examples such as, performance, security, and recovery. Additionally, it assists developers with patching, backups, and database configuration. For our purposes, MongoDB Atlas is free since we are not going to need dedicated clusters. In other words, we are not going to be commercialized.

Even though, some of the following features are irrelevant to our project they are still present and can possibly become useful.

1. Scalability: Upscale or Downscale is simple and has no downtime.
2. Global Clusters: Low latency writes globally.
3. Alerts and Monitoring allowing developers to catch issues.
4. Strong Security: Integrated protection
5. Disaster Recovery: Consistent backup and recovery
6. Workload Isolation: Concurrently run functional and analytical workloads in the same database.

3.8.9.2 Web Hosting

We will be using Heroku, arguably the fastest way to deploy an application on the internet. It allows developers to simply spend their time developing and worry less about deployment. Heroku allows for scalable applications, takes care of security and operations. Heroku provides of 175 add-ons that giving us more room more expansion and more options in general when it comes to developing the application. It is free to use for our application, the restrictions that come from using the free service do not affect us on this project. Heroku also comes with a Command line Interface that allows developers to manage their applications.

The main disadvantages for Heroku are the lack for a static IP address, limited dynos, and the fact that is only available in US and European regions. The static IP address is not a huge deal for us since our application is small in comparison to businesses and applications that require a static IP. Additionally, the fact that Heroku is only available in the US and in Europe is not a problem since we only plan on using the app in the US. By Dynos we mean virtual Linux containers that are used to run code and or commands. There is a limited number of Dynos with different specifications such as memory, CPU limits, and dedicated server variations. Since our application is small and light this is also not a problem for us.

Some alternatives to Heroku are Back4app, Google App Engine, Parse, Engine Yard and Firebase. We were in between Heroku and Google App Engine but ultimately decided to host on Heroku due to familiarity.

Table: 15 Heroku vs Google App Engine

	Heroku	App Engine
Service	Amazon Web Services	Google Cloud, which is more reliable than AWS
Flexibility	Extremely flexible	Lack of flexibility static attempts to tie you in to google services.
Pricing	Simple	Convolutd

4. Design

4.1 Application

We will discuss application design related to the database and the prediction as to what the client-side user interface will possibly look like.

4.1.2 Database Design

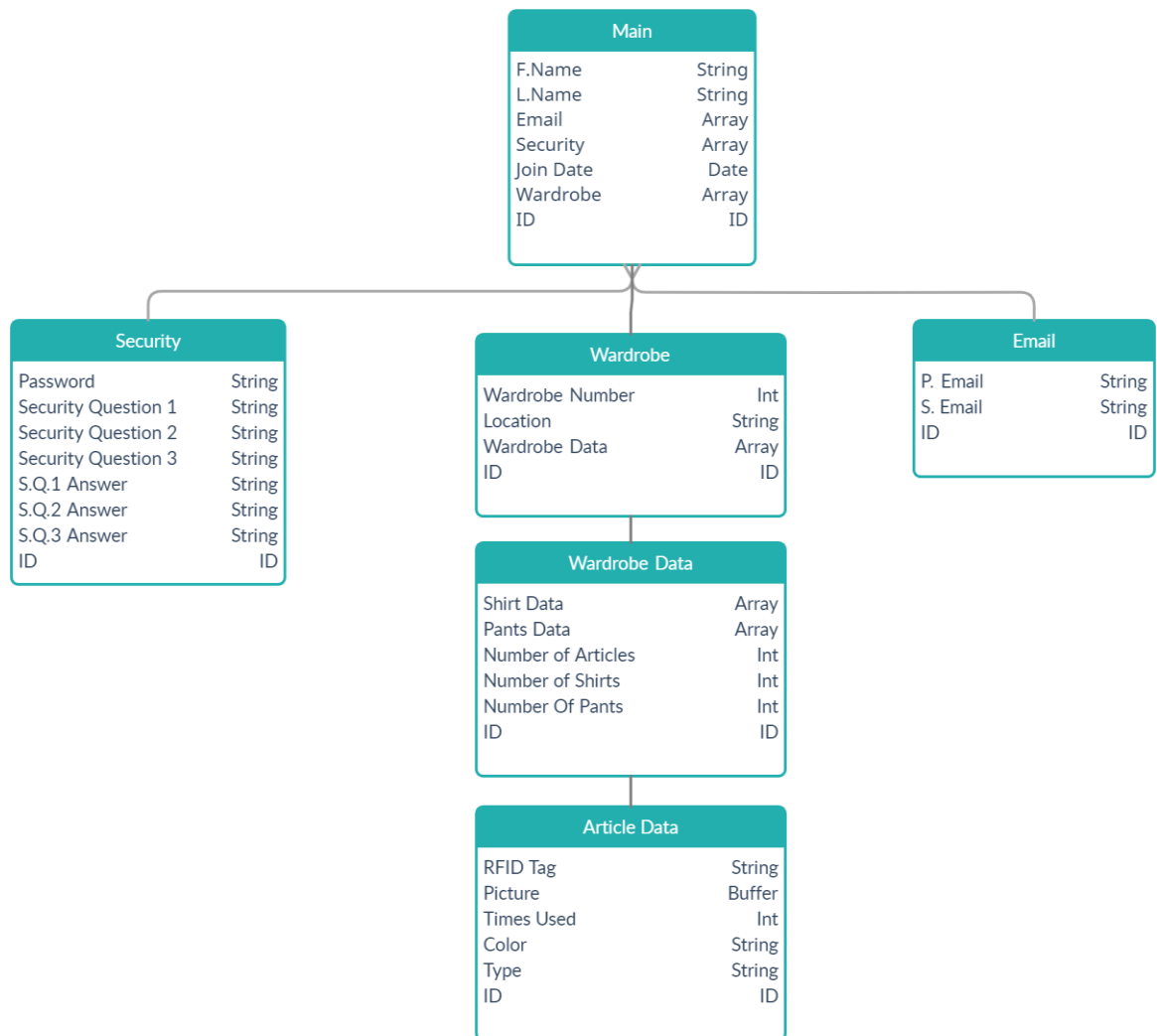

Figure 63: Completed Database Model

The Main Schema will contain most of the primary information of the users as well as the arrays containing the data for the other five “tables” in our database. As stated earlier, the lack of “tables” and primary and foreign keys in a NoSQL database is not a problem. We do not have to relate the data in any way shape or form since each user will have its own independent instance of Security, Wardrobe, Wardrobe Data, Article Data, and Email. Users will have to provide a first name and last name, a primary and secondary email, followed by a password (that will be hashed when it arrives at the server) and multiple security questions and answers. If the user is adding a wardrobe for the first time, they will need to provide the wardrobe location. The wardrobe number will be automatically generated based on the current number of wardrobes the user has added. When inputting an article of clothing into the wardrobe the user needs to select what type of article it is (shirt or pants), the color, a picture and most importantly the RFID tag.

An Example of a JSON file being send to the server and then being added to the database.

```
{  
  "F.Name" : "John",  
  "L.Name": "Doe",  
  "Email1": "123@gmail.com",  
  "Email2": "456@gmail.com"  
}
```

Figure 64: JSON Package

This sample package will be sent to the corresponding API end point and processed by the server. The server will then add the create a user and add the corresponding information to the database. Security and wardrobe will be set to an empty array when creating a new user. User ID and join date will be automatically created when a new record is created. The plan in to send the password in the same package and hash it when it gets to the server, but we have yet to confirm what our plan will be.

The following is an example of how the database looks like in Robo3t, granted some fields are missing and the object IDs are the same but this is just an example.

```

{
  "_id" : ObjectId("5f1b430b321c860004efc87b"),
  "FirstName" : "John",
  "LastName" : "Doe",
  "Email" : [
    {
      "_id" : ObjectId("5f1b430b321c860004efc87c"),
      "Email1" : "123@gmail.com",
      "Email2" : "456@gmail.com",
    }
  ],
  "Security" : [
    {
      "_id" : ObjectId("5f1b430b321c860004efc87c"),
      "Password" : "default",
      "SQ1" : "default",
      "SQ1A" : "default",
    }
  ],
  "Wardrobe" : [
    {
      "_id" : ObjectId("5f1b430b321c860004efc87c"),
      "Number" : "default",
      "Location" : "default",
      "Data" : [
        {
          "_id" : ObjectId("5f1b430b321c860004efc87c"),
          "ShirtData" : [{}],
          "Pants Data" : [{}],
          "NumberA" : 0,
        }
      ],
    }
  ],
  "Date" : ISODate("2020-07-24T20:22:35.788Z"),
  "__v" : 0
}

```

Figure 65: Database inside Robo3t

4.1.2 Client-side user interface

This is a sample user interface for the web application. This is simulating adding an article of clothing to the database. This is a very rough draft and its only meant to simulate a form. The form asks for specific information that is going to be validated on the client side. This form for example will proceed to perform a POST request and send the information in a JSON file to the server. The server will then send a code corresponding to success of an error. The error will be displayed on the client side. Most of the validation will be done prior to sending the JSON file to the server.

Wardrobe Inventory Home About Contact Login Register

Wardrobe Number

Article Type

Article Color

RFID TAG Type

Check me out

Figure 66: Sample Data Input

4.2 Standards and Design Constraints

In this section details the standards and design constraints that will show the Personal Wardrobe Assistant's parts selection, features, and design.

4.2.1 Standards

Standards are considering an important parameter in which we take the design of any system. In this section the purpose is to specify the important standards of each of the components that applies to the Personal Wardrobe Assistant.

4.2.2 Antenna Standards

The antenna standards involve that it could scan the RFID tag at a certain distance without having any complications. The standard is not to make a huge antenna neither a small antenna. A big antenna would cover too much space in our design and will scan from a greater distance, and that's not what we want. Neither we want to build a small antenna that the user needs to scan getting the RFID close to the antenna. There is going to be build different antennas with different sizes to see which one is the most practical.

4.2.3 RFID Reader Standards

The RFID reader standards is to be able to receive the information of the RFID tag that was scanned on the antenna and be able to send that information to the microcontroller. All this can be made possible using the INT pin to communicate to the microcontroller.

4.2.4 Microcontroller Standards

Standards for the microcontroller will involve proper use of UART connection between controller and reader. The microcontroller will also properly be connected to a Wi-Fi access point and send information via POST request to the database.

4.2.5 Voltage Supply Standards

The voltage supply has a to be a consistent and reliable source of power for every indivial part of the project. The goal is to ensure that the power supply is stable and doesn't overload any components. If too much voltage is supplied to any of the given parts then it could cause irreparable damage to the individual pieces. If too little is delivered the components won't even turn on. Also the design needs to create a smooth output signal so that the antenna can have the optimal range as specified in the house of quality. The main system will deliver 5V and the subsystem will deliver 3.3V.

4.2.6 Design Constraints

There is no project that would function without a lot of work and sacrifice. This Personal Wardrobe assistant is no exception. In this section we are going to describe the constraints that it challenges us in the design of our Personal Wardrobe Assistant.

4.2.7 Antenna Design Constraints

This could be challenging when we talk about designing an antenna from scratch. It involves a good amount of time and work to make it functional. For the antenna, it is necessary to provide a distance range to scan the RFID so the user can update their wardrobe information through the app. The things that come into play is the copper wire thickness and the diameter of the antenna. These two combined will determine the range and the power necessary to scan the RFID in a convenient distance so the user doesn't struggle if the RFID tag has to be really close to the antenna to scan or if it scans too far away. This element is the key to make the antenna user friendly, getting a range that can be enough, so the user won't have any issues.

4.2.8 RFID Reader Design Constraints

The design constraints that the RFID reader has is the use of UART. This reader is well known to use with Arduino using I2C configuration. UART is also possible but it remains to be a challenge since there's not too much information available to be able to connect it via UART.

4.2.9 Microcontroller constraints

Constraints of the microcontroller will be the power delivered to it, Keeping the controller in LPM (Low power mode) until the device is in use, and creating the proper connections to communicate to the LCD screen. 5VDC is needed to power the microcontroller. Low power mode must be achieved after a 60 second duration of inactivity. Lastly, to communicate with the LCD screen two 4.7k ohm resistors are required to complete the I2C circuit for communication.

4.2.10 Voltage Supply constraints

The biggest constraint relating to the supply system is that a voltage regulator with smoothing capacitors is not just the most efficient but essentially required. The Antenna strength is very sensitive to the DC output and according to the datasheet the ideal method of generating a signal for the reader is with a voltage regulator and smoothing capacitors. Using the capacitors allows the group the most simple way of tuning the DC signal. The DC output is required to be a smoothed signal, otherwise it would cause issues for the ID-3LA reader. A relatively large battery pack was also required because the power circuit would be providing power to two different components.

During the testing and design phases the biggest restraints were availability of parts and time. There were restrictions for going onto Campus during COVID, reservations had to be made beforehand. The proper capacitors for the final design were acquired but testing out other options, like the voltage divider or purely diode regulator were not an option because these materials could not be obtained easily. Also when doing testing from home all the parts had to be ordered and testing happened in a none ideal environment.

4.2.11 Time Constraints

Time is one of the biggest enemies for an engineering project to get done. This Personal Wardrobe Assistant is no exception to the rule. To design a good engineering product could take a good number of experienced engineers, setting goals, and years to get the best of it. In our case, we only have around two semesters to complete the design, functionality, and constraints that this project demands. The impact of these time constraints limits the amount of time we must solve the problems and the challenges that this Personal Wardrobe Assistant faces, which cuts some time to optimize the antenna design, the app functionalities, and so many other things that will need to add to this project.

One of the challenges that will face is how this time constraint would affect our milestones in a significant way, meaning that we probably will not meet our stretch goals. Every component that the Wardrobe needs like the Antenna design, the reader, microcontroller, the app, and so many others would consume too much time that we do not have to meet each of the deadlines.

4.2.12 Experience Constraints

Today's many products like smartphones, tablets, ANC Headphones, and so many others are made by an experienced team of engineers. Companies like Apple, Microsoft, Intel hires engineers with some related experience to work on their companies.

Since our group doesn't have the experience dealing with the technologies that this Personal Wardrobe Assistant demands, it challenges each one of us to make this work.

This means that our lack of experience would bring more challenges and more time spent on our design, research and the methods that we need to consider making this Personal Wardrobe assistant. Lacking experience means to redo a lot of testing, finding multiple solutions and even figuring things out in a short amount of time.

One of the biggest challenges that we're facing in our project is the creation of a PCB board where we have to insert layouts for our different components. Our team has a lot of theory knowledge but putting this theory into practice can be such a challenge since time is not in favor. Laying out a circuit board requires spending time on how to use different programs and knowledge of how to put things together. The result is making mistakes on how to connect each component and time loss on correcting these mistakes.

4.2.13 Resource Constraints

Most companies have a certain percentage of their budget for their development of their products. Big companies like Apple spend billions of dollars on developing new technology for their products. Even the US military spends hundreds of millions of dollars to develop their newest weapons and fly jets.

Our reality is that being students is having not enough money to spend on things that we really would like to have. In terms of this project, we are spending money on so many parts and components that need to be purchased in order to build the Personal Wardrobe Assistant. It's been a little bit of a challenge to find the components locally, leaving us to research on the internet, reading datasheets, specs, in order to buy these and test them. It could take 1-2 weeks to get such important parts that are necessary to our project.

Another resource constraint is that most of the equipment that we need to test our parts are located at UCF. This means that we mostly depend on it and some of our team members leave far from there.

5. Personal Wardrobe Assistant

This section details the overall design of the various aspects of the Personal Wardrobe Assistant that would be broken up in various sections.

5.1 Hardware Design

This section covers the hardware aspect of our Personal Wardrobe Assistant's design, divided into various parts.

5.1.1 Hardware Design Power system

For the power design the main component that requires voltage is the ID-3LA reader. It requires a voltage of 2.8-5.5V in order to start. Once it receives power the reader it sends a current to the antenna. The LCD screen, which the user will use to interact with the system, also requires 5V in order to operate successfully. Permission was obtained from ID-innovations to use the basic power circuit pictured below.

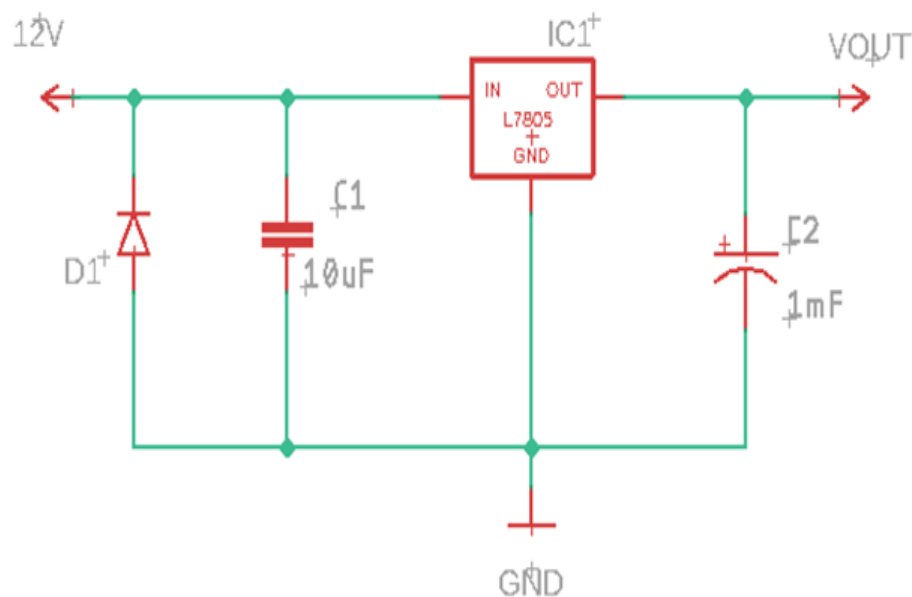

Figure 67: tentative power circuit

The circuit consists of five major parts. The voltage regulator, the two capacitors, a diode, and the voltage pack. According to the data sheet of the ID-3LA, the maximum capacitance for C1 is 10uf 25V electrolytic. The maximum value for C2 is 1000uf 10 V electrolytic. When testing the final antenna design the capacitance values can be altered to increase the strength of the signal. Even though the final power design was tested with the antenna fine tuning was not able

to be completed because of time and social restrictions due to both school and Covid. Individual testing was possible though and the construction of a basic prototype. When measuring the output, the desired output voltage of 5V was once again achieved with the final set up. The design is limited to this basic board because the form of the DC output directly affects the performance of the antenna.

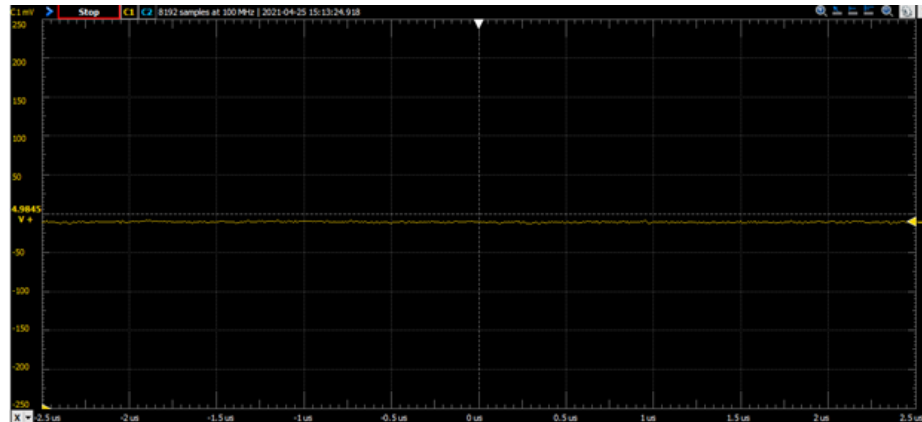

Figure 68: output final power circuit

The basic design of the power circuit is very limited because it is very simple with only one primary job. The voltage itself cannot be altered because of design specifications. During the initial testing three regulators were lost due to human error. Therefore, a diode will be present in the final circuit design as well. A diode only allows current to flow in one direction. In power supplies it acts like a safety mechanism to ensure the current only flows toward the input of the regulator. This achieves two things for the design. One it increases the safety of the circuit and makes the likelihood of the regulator overloading less likely. This steady current also allows for a steadier output signal which is beneficial for performance.

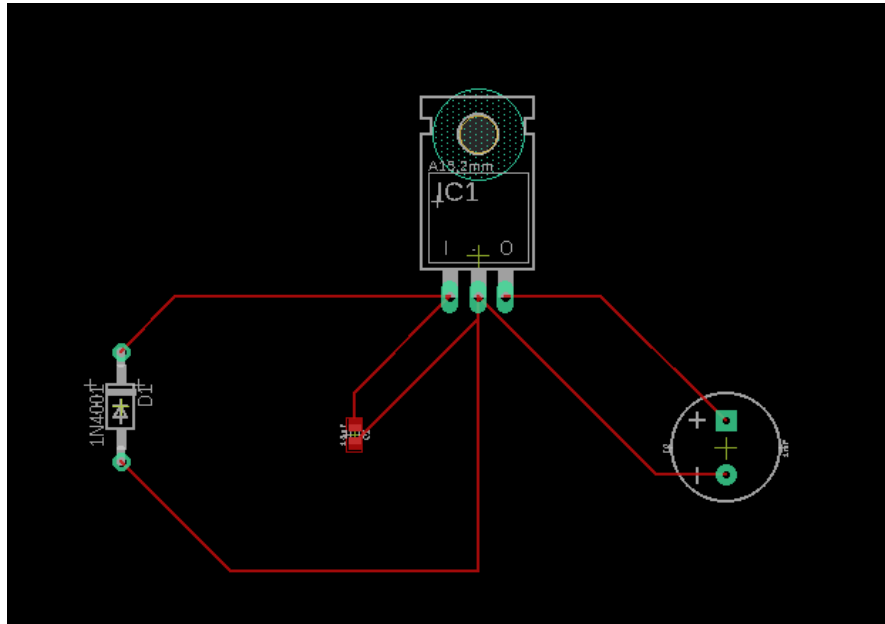

Figure 69: PCB power circuit

The PCB design was created using the schematic software EAGLE. All the components had to be downloaded from separate libraries and were not part of the standard EAGLE library. This was beneficial because the group had to refamiliarize itself with the EAGLE Software, which is one of the most widely used schematic software's in the electrical engineering industry.

5.1.2 Hardware Design RFID Antenna

The antenna design is a critical subsystem since it is the starting point of our Personal Wardrobe Assistant to scan RFID tags and receive the information that the user needs to take care of his/her clothing inventory. To design an RFID antenna it is necessary to have some copper wire and some PVC tube of different diameters. There are 2,3,4-inch PVC tubes with some 28,30, and 32 AWG enameled copper wires. Combining these two elements, we were able to build a total of 9 antennas to test them out and look for the one with the best range.

To build each antenna, we measured the inside diameter of each PVC in mm.



Figure 70: PVC with different size

Table: 16 PVC inner diameter

PVC (in)	PVC (mm)
2-inch	68mm
3-inch	86mm
4-inch	113mm

Table: 17 Antenna number of turns

AWG	Diameter Size(in)	No. of Turns
28	2	98
28	3	87
28	4	76
30	2	99
30	3	88
30	4	77
32	2	100
32	3	88
32		77

After measuring each PVC inner diameter in mm, there is a website in which we add the inner diameter of the desired measurement in mm, the AWG copper wire size and the inductance of the antenna that we want to get. Based on the ID-3LA reader, we need an inductance of 1.337mH to get the antenna to work. A screenshot of the calculator can be seen on Appendix B Figure B-2. The results will be shown on the next table.

After getting the values of how many turns it needs each of them, then we start to loop the copper wire around each PVC tube. Getting the copper wire around the PVC could take around 20 to 30 minutes since each copper wire has to be close to each other. Each PVC wire was taped with paper to keep the copper wires to move around and maintain them in place. The numbers obtained were rounded to the nearest tenth. So, we ended up getting all the sizes the same

around the loops. For the 2-inch we got 80 loops, 90 loops for the 3-inch, and 100 loops for the 4-inch.



Figure 71: PVC wired with enameled copper

Now that the antennas are built, it's time to connect them to the reader. To connect the antennas with the reader it is necessary to connect them to an Arduino device. On the Sparkfun website, they sell an RFID Qwiic Reader and a RFID kit that can be connected to I2C. This can be found on Appendix Figure B-3 and B-4. The good thing is that the Qwiic reader does not need to be programmed to read the RFID tags since it contains a buzzer. We tested out with an ID-12LA reader which has the integrated antenna and was scanning without having to do any code. The same works with the ID-3LA. We connect them to the RFID kit and RFID Qwiic Reader, solder some pins and connect the antenna into the respective pins, ANT1 and ANT2 (look at Figure 9).

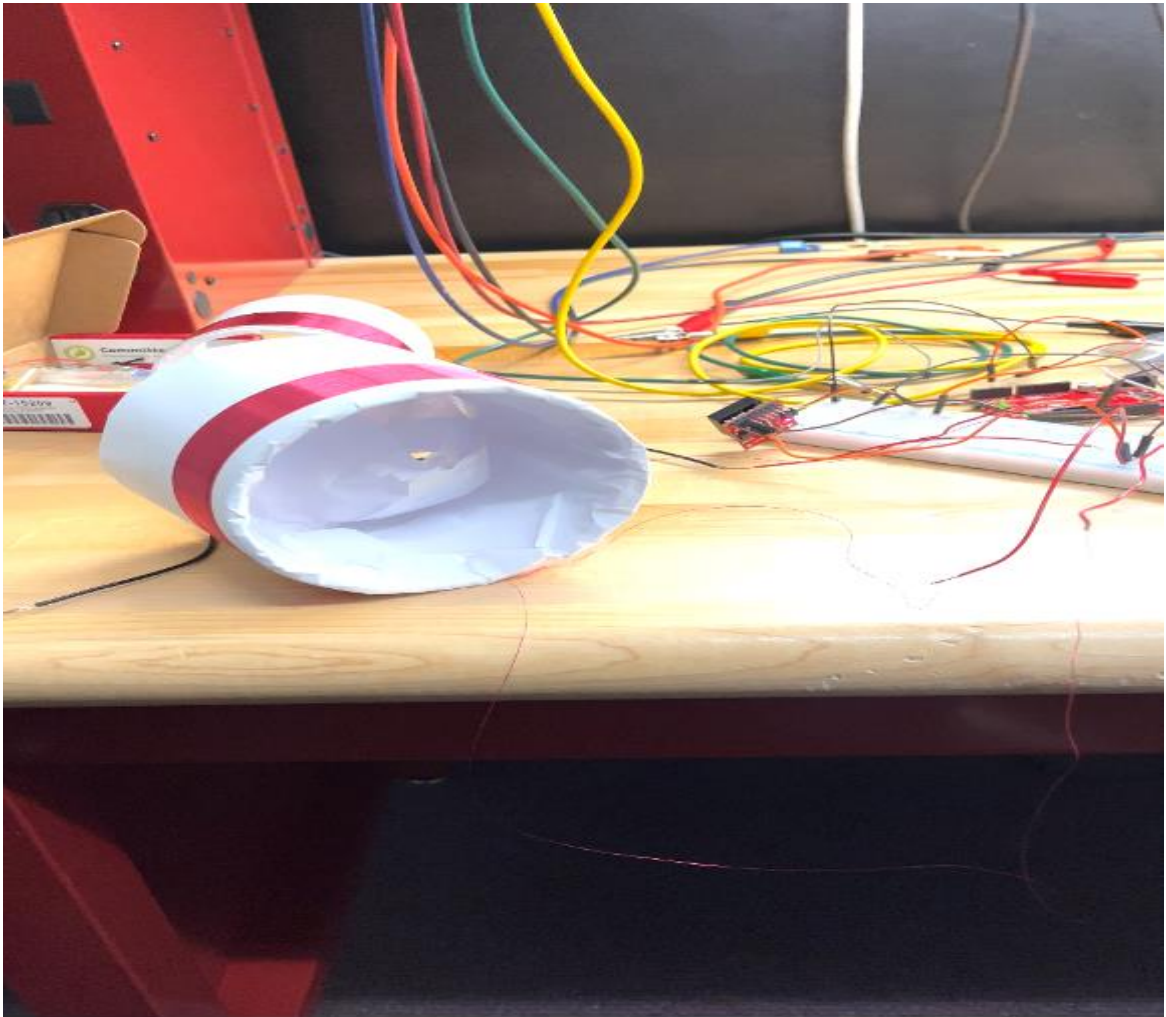

Figure 72: Testing Antenna, ID-3LA Reader on RFID Qwiic kit connected with RFID Qwiic Reader

To test the antennas, we connect the oscilloscope to the ANT1 and ANT2 pins of the RFID reader to check the voltage peak-to-peak, frequency (which should be 125KHz) and the range of each of the antennas. There's going to be two different trials: (1) Antennas without tuning up, which means not altering the loop acquired from the calculator, and (2) tuning up the antennas which will be adding/taking more loops in order to expand the range. All this information will be shown in two different tables. The first table will be adding a column of expanding/compressing waveforms.

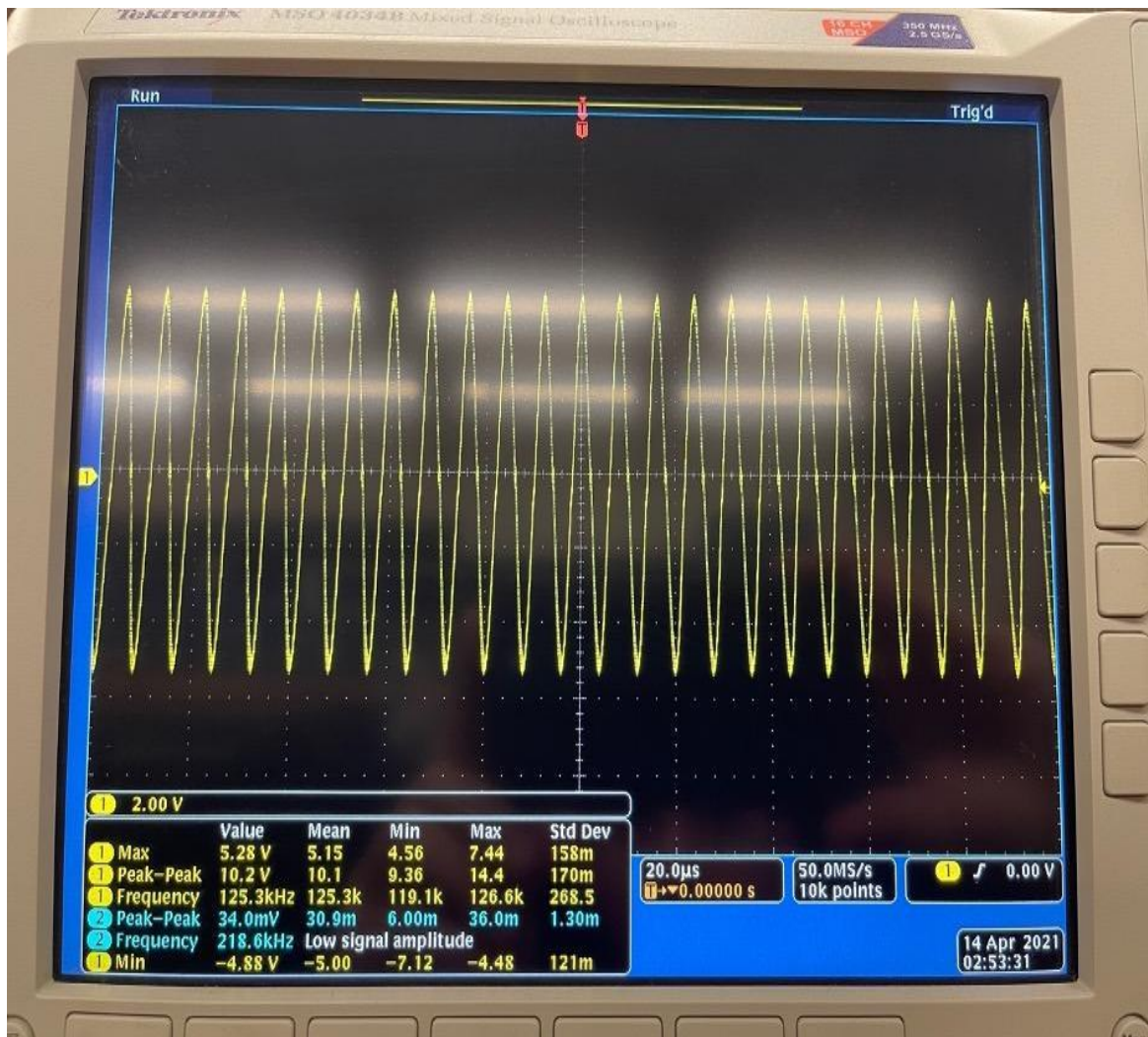

Figure 73: Output Waveform of the Antenna

When we talk about expanding/compressing the waveform is when you get the RFID tag closer to the antenna and the waveform gets either larger or smaller. When the RFID tag gets closer to the antenna and the waveform expands it means that it does not have enough inductance and needs to add more cable to the coil. On the other hand, if the waveform compresses it means that it has too much inductance and the copper cable needs to unwind some cable from the coil.

Table: 18 Results for Antennas without tuning up

AWG	Diameter Size (inches)	Number of Turns	Voltage Peak-to-Peak (V)	Range (cm)	Waveform Compress/Expands
28	2	100	3.8	N/A	Expands
28	3	90	6.28	1	Compress
28	4	80	9.6	5	Compress
30	2	100	2.84	N/A	Expands
30	3	90	6.8	8	Compress
30	4	80	15	13	Compress
32	2	100	10.1	0.5	Compress
32	3	90	10.2	2.5	Compress
32	4	80	10.2	5.5	Compress

Table 19: Results for Antennas with tune-up

AWG	Diameter Size (inches)	Number of Turns	Voltage Peak-to-Peak (V)	Range (cm)
28	2	112	7.6	5
28	3	84	9.6	7
28	4	75	10.5	8
30	2	114	8.9	8
30	3	86	8.6	13
30	4	76	17	9
32	2	94	11.5	7
32	3	87	13.6	11
32	4	74	14	13

The results obtained with the antennas were shocking. 7 out of the 9 antennas were scanning the RFID tags. The two antennas that were not working are the ones that the waveform expands, meaning that they need to wind more copper wire. Based on the results, the antennas that get the highest range are the 3-inch and the 4-inch from the 30 AWG copper wire.

Now we are going to run a second trial test making sure that this time, all the antennas can read RFID tags at their optimum state. For the two antennas that were not working, it will have a total of 120 turns on the coil, an increase of 20% to start tuning them up and make them scan RFID tags.

Based on the results obtained, we can determine that all the antennas can scan tags at this point. It is important to mention that the 30 AWG of 2-inch is giving the best range out of the other 8 antennas. The smaller the coil, the better to increase the field strength and coupling.

5.2 Testing microcontroller & other components

In this section we will be testing the functionalities of the microcontroller and several components involving the operation of the microcontroller. We will measure power delivered to the microcontroller & power delivered to an LCD screen. We will also be testing the functionality of UART on the microcontroller. This will require several components in order to test. There will be sample code used from our online resource in order to test the microcontroller's ability to connect to a Wi-Fi access point and send POST requests. Next, we will check the functionality of the LCD screen and display strings of characters to the LCD screen. Lastly, we will check the functionality of buttons we will use for the user to navigate the settings on the microcontroller when connecting to a Wi-Fi access point.

5.2.1 Powering ON microcontroller

To power on the microcontroller, we will be making use of the power delivered by USB. Below is a physical picture and a pinout of a standard micro-USB layout.



Pin	Name	Cable color	Description
1	VCC	Red	+5 VDC
2	D-	White	Data -
3	D+	Green	Data +
4	ID		Mode Detect
5	GND	Black	Ground

Mode Detect. May be N/C, GND or used as an attached device presence indicator (shorted to GND with resistor)

Figure 74: microUSB pinout

Although there are data lines coming through the micro-USB, we will only make use of the +5 VDC which is delivered through pin 1. Testing this is quite trivial and simply connecting the opposite end of the micro-USB cable to our computer will do the job.

We then plug in the micro-USB into the microcontroller. Upon plugging in the micro-USB into the microcontroller, LED lights begin to flash and our computer is registering the device as detected and actively communicating.

5.2.2 Testing Wi-Fi functionality of the microcontroller

To test the Wi-Fi capabilities of the microcontroller we must first install Arduino IDE and configure the IDE to detect the Adafruit feather Huzzah. In the previous section we discussed how to configure the Arduino IDE so we will not revisit this topic here. After configuring the Arduino IDE to detect the microcontroller we will now need to execute the sample code on the Adafruit website to test the microcontroller. Here is a link to the code

https://learn.adafruit.com/adafruit-feather-huzzah-esp8266/using-arduino-ide?gclid=Cj0KCQjwgtWDBhDZARIsADEKwgPcuna_Tj-TeCPk3bf2qEa9Vs84H6qIIPAg0MNHQFLocHJ0JliS8JgaAvHnEALw_wcB

We compiled and executed the example code and our test was successful! We were able to not only connect to a WiFi access point but also test that we can send POST request to a sever. Below is a screen shot of the serial monitor of the data from the server.

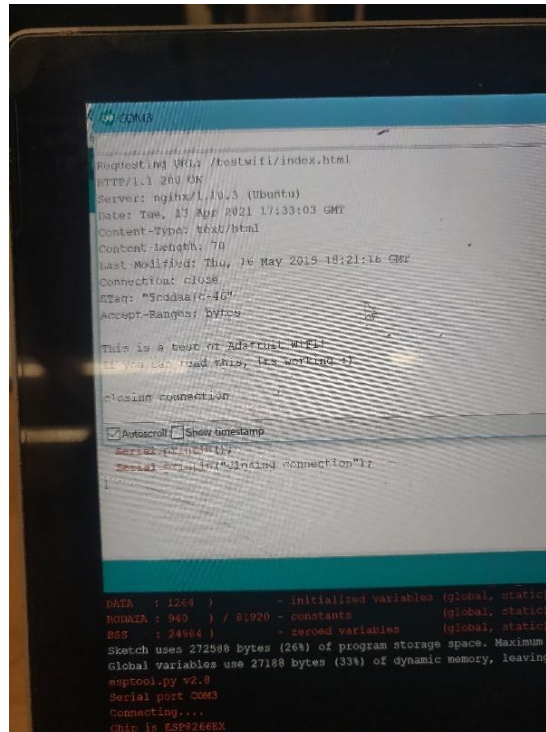

```
Requesting URL: /testwifi/index.html
HTTP/1.1 200 OK
Server: nginx/1.10.3 (Ubuntu)
Date: Tue, 17 Apr 2021 17:33:03 GMT
Content-Type: text/html
Content-Length: 70
Last-Modified: Thu, 16 May 2019 18:21:16 GMT
Connection: close
ETag: "5edd517c10"
Accept-Ranges: bytes

This is a test of Arduino WiFi!
If you can read this, the script is
closing connection.

Autoscroll [x] Show timestamp
Serial.println();
Serial.println("closing connection");

MEMO : 1264 ) - initialized variables (global, static)
ROM2A : 940 ) / 81920 - constants (global, static)
MEM : 24864 ) - zeroed variables (global, static)
Sketch uses 272598 bytes (26%) of program storage space. Maximum is 1024000 bytes.
Global variables use 27188 bytes (33%) of dynamic memory, leaving 50412 bytes free.
esp8266.py 72.8
Serial port COM3
Connecting...
Chip is ESP8266EX
```

Figure 75: Serial Output of WiFi connect and POST request test

Being able to send POST request is the driving force when connecting to our remote database. There will be further rigorous testing on this topic later on, but for now the basic Wi-Fi connection is stable and we can connect to a web server.

5.2.3 Testing UART functionality of microcontroller

5.2.3.1 Set Up & Measurements

For this project our primary mode of communication will be UART. In order to test the microcontroller for its UART capabilities we will be using our back up EM18 RFID reader to send data across the TX – RX bus from reader to microcontroller. To begin we need to first send power to the EM18. We will be

making use of the MSP430 in order to send +5 VDC to the EM18 RFID reader. By utilizing a bread board, we can use the positive and negative rails to provide a simple source of power to the EM18 reader and a common ground for the entire circuit. After establishing the +5 VDC to the RFID reader we now can establish a common ground for the entire circuit. Using the GND on the MSP430, we connect it to the negative rail on the breadboard. Next, we must pull up the SELECT pin on the EM18 RFID reader to +5 VDC in order to make use of the RS232 connection. This wire will also be connected to the positive rail on the bread board and attached to the SELECT pin on the EM18. Now we must connect the microcontroller to the circuit. To utilize the UART connection we must establish a common ground between the reader and the microcontroller. So, we connect a wire from the GND pin on the microcontroller to the negative rail on the breadboard. Lastly, the only thing left to do is connect the TX pin on the reader to the RX pin on the microcontroller. Before we compile the sketch on the Arduino IDE to test. We must measure the voltage on the positive rail of the breadboard to ensure we are within range of +5 VDC. We utilize the Analog Discovery 2 and the Wave Form application for Windows to measure the power delivered to the circuit. Below is a screen shot of the output.

As shown in the screen shot, we are receiving 4.874 – 4.474 VDC from the MSP430. This is certainly in tolerance to power the EM18 and pull up the SELECT pin to RS232. Next we will continue to execute the code and show the output.

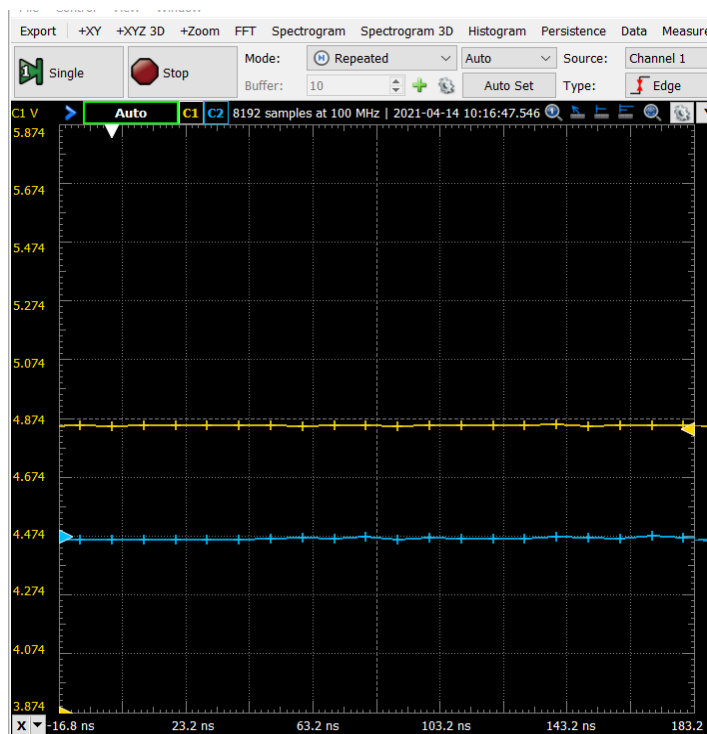

Figure 76: Voltage output of MSP430 power supply

5.2.3.2 Execution

Now we will compile the sketch on the Arduino IDE and program the microcontroller to receive the information from the reader upon scanning an RFID tag. After positioning an RFID tag within the minimum proximity to be detected by the EM18 RFID reader, we begin to witness the serial monitor on the computer propagate the information from the RFID tag. Below is a screenshot of the output.

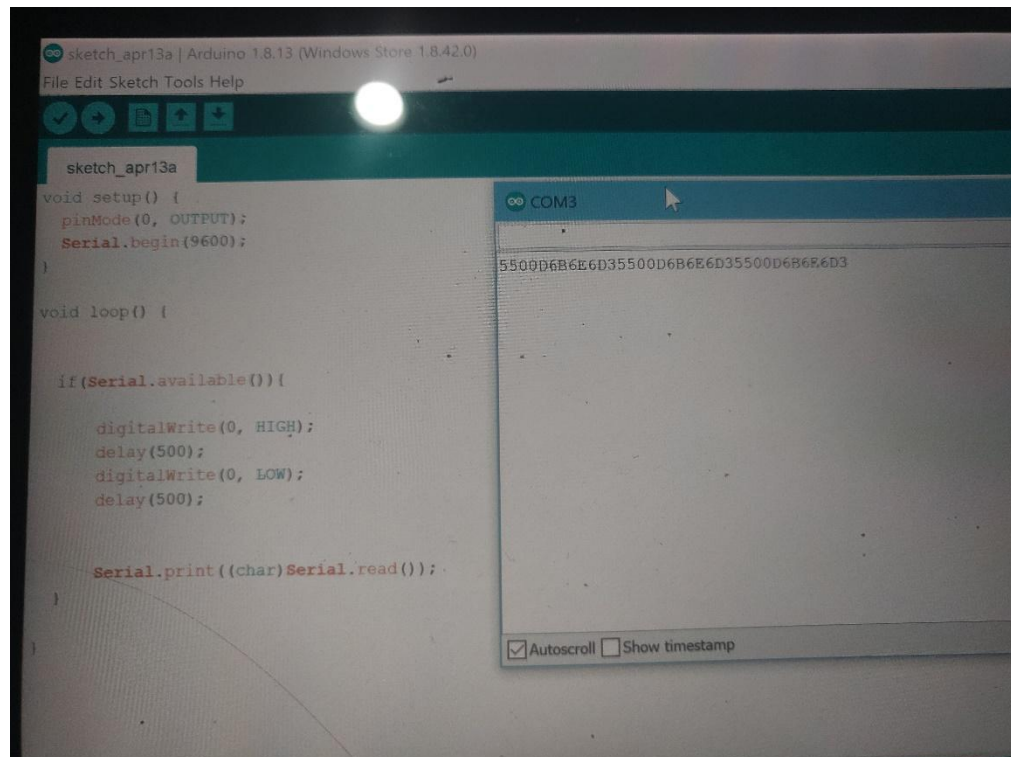

Figure 75: Serial output of EM18 test

The RFID tag information is written to the serial console as 5500D6B6E6D3. In this scheme as stated in previous sections 10 characters are dedicated to the RFID tag number and the last two characters are the check sum which is a XOR operations of the last 10 characters.

Below is a screenshot of the test setup and a wiring diagram of the test setup.

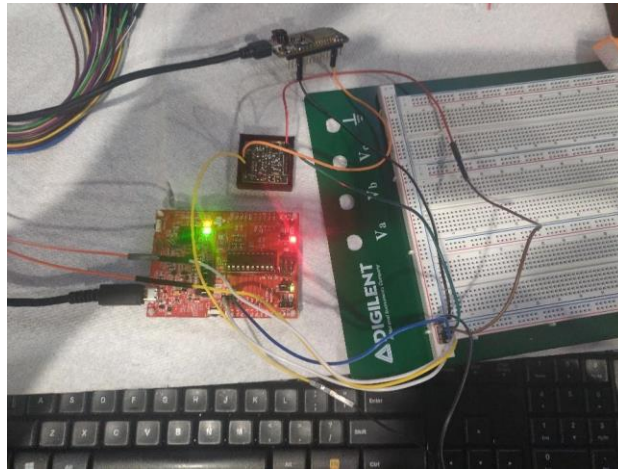

Figure 78: Physical test circuit for EM18

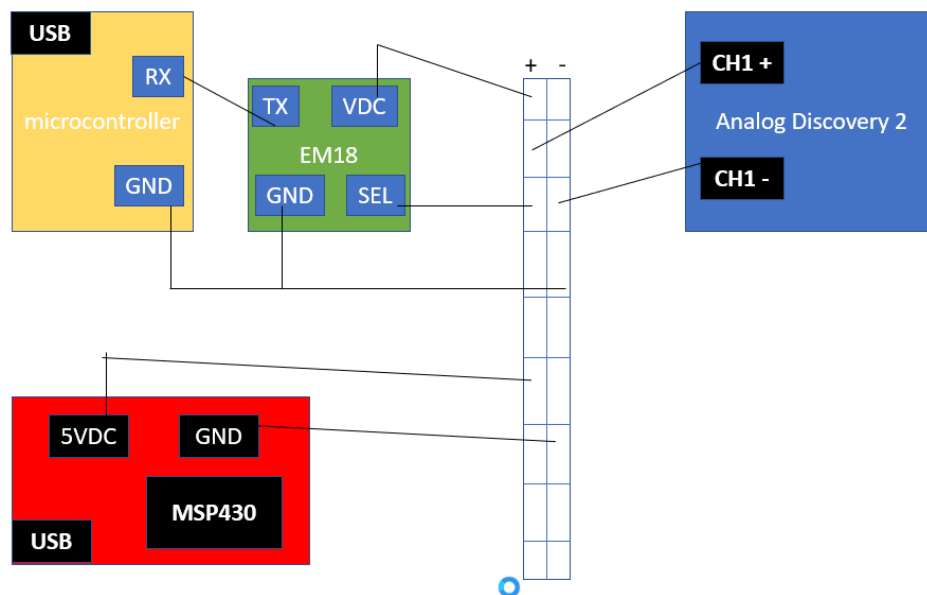

Figure 79: EM18 test circuit

Notes:

We ran into a few issues with testing the UART capabilities of the microcontroller. Our project is planned and designed to use the ID-3LA to make use of the independent antenna capability, but during the time of testing we did not have the means to test the ID-3LA, so we defaulted to simply testing UART using our backup RFID reader the EM18.

Upon making all of the connections initially the EM18 seemed to not be working. We tried several different configurations to solve this issue and after 6 to

7 hours of troubleshooting we were able to figure out what was wrong with our set up. The pins on the microcontroller are a little bit misleading. Instead of plugging the wire into the RX pin, we accidentally placed the wire on the TX pin. After making this change, the information from the EM18 worked like a charm.

5.2.3.3 Testing ID-12LA

The EM18 is a great RFID reader but unfortunately it is not a part of our primary design in this project. The ID-3LA is the primary RFID reader and will be used in our final prototype. Reason being is because with the ID-3LA we can create and tune our own antenna. For testing purposes, we will be using the ID-12LA which is similar to the ID-3LA in its design and the use of UART to communicate to the microcontroller. We will begin testing the ID-3LA against the microcontroller when our antenna has been properly tuned.

For the ID-12LA to communicate via UART with the microcontroller we must connect the TX pin of the ID-12LA to the RX pin of the microcontroller. The equivalent pin is D0 on the reader. We will be using 3V3 volt DC from the MSP430, like the way we have been using it to power the EM18. After connecting the power, we must ensure that the ID-12LA and the microcontroller are sharing a common ground. This will allow them to be in sync with each other. Below is a screenshot of our setup and a wiring diagram of the components.

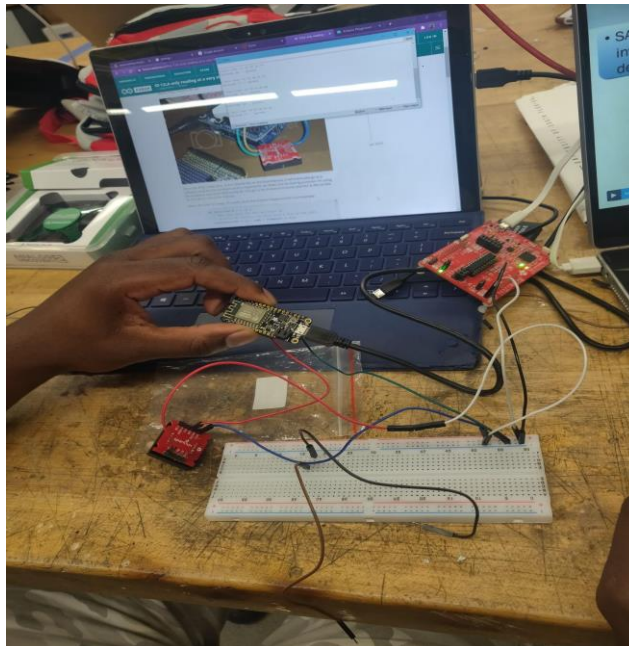

Figure 80: Physical picture of the ID-12LA test circuit

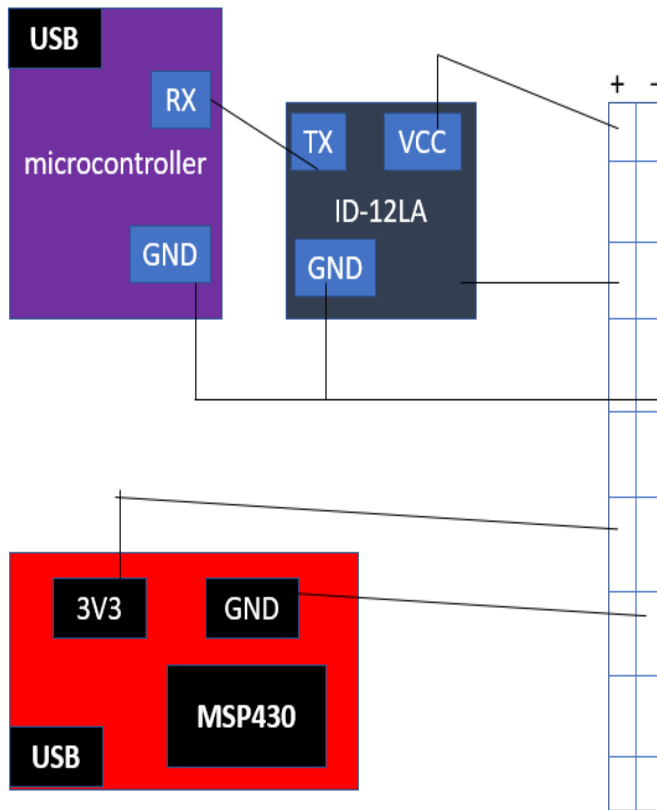

Figure 81: ID-12LA circuit

5.2.3.4 Results:

A few things to mention. We used some sample code online to interface with the reader. Initially our circuit was not working at all. After altering some lines of code, we were able to detect some information on the serial output. This information was unfortunately unreadable and contained foreign characters. After troubleshooting and reassessing our set up, we noticed that the TX pin on the reader was connected to D1. This is the reason why we were reading unrecognizable characters in the serial output. After switching to the actual TX pin which is D0. We were able to read the information on the RFID tag which came in the form of hexadecimal. Below is a screenshot of the output of the serial monitor.

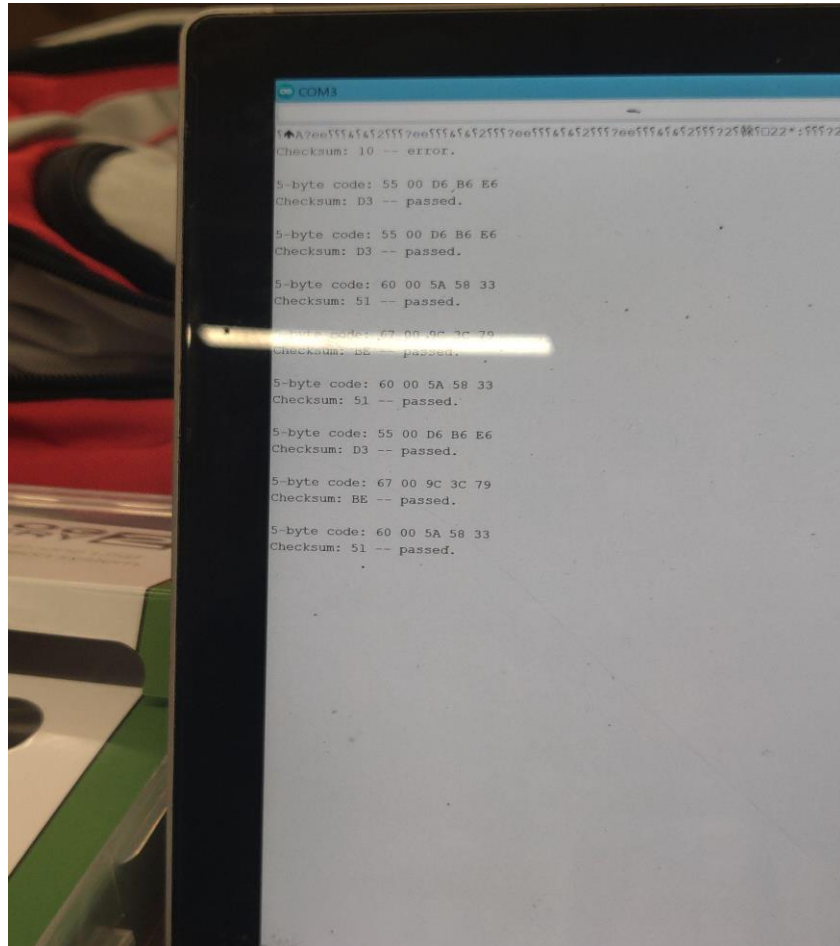

Figure 82: Serial Output of ID-12LA test

5.2.4 Testing power & functionality of LCD screen

We will be using the same +5VDC set up from our MSP430 to power on the LCD screen. The LCD screen is a 16x2 character screen, This should be more than enough characters to operate the personal wardrobe assistant module. Sending power to the LCD screen is as simple as connecting the +5 VDC and GND to each respective side of the rail on the breadboard and then to the LCD screen pins VCC and GND. Upon connecting each respective pins, the backlight of the LCD immediately light ups. The LCD screen successfully is powered on. Below is a screenshot of the LCD.

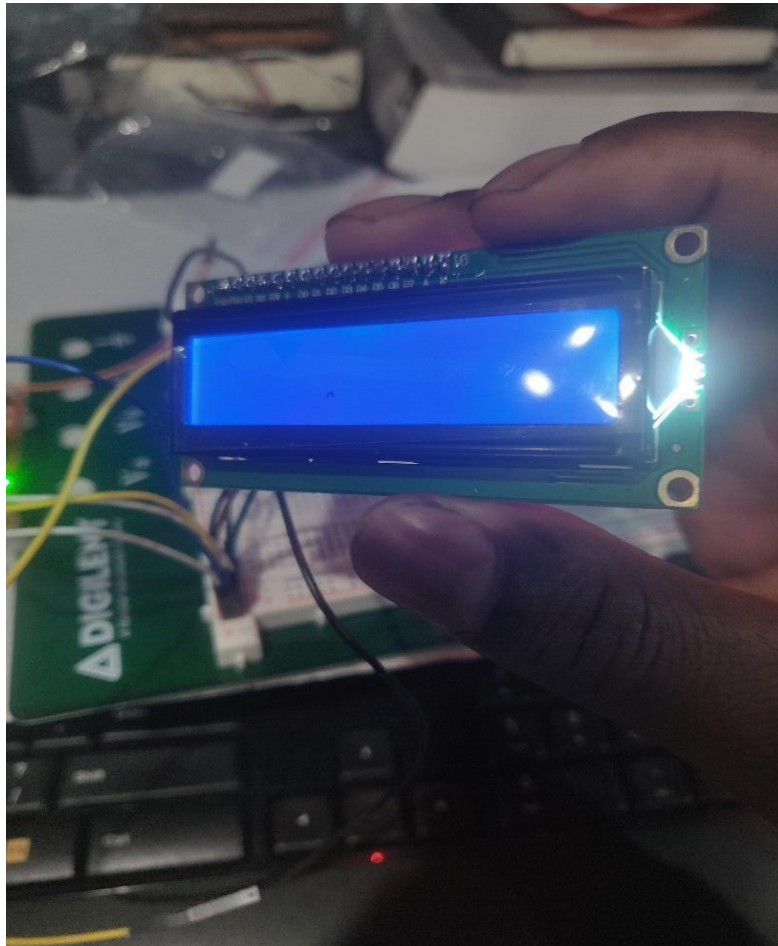

Figure 83: LCD screen Powered ON

The next thing to do is to test the functionality of the LCD screen and print strings onto the display. The LCD screen communicates with the microcontroller via I2C which uses two bus lines. SDA and SCL which are the serial data and serial clock. We connected these two pins to the LCD, respectively. Then connect the opposite end to the respective SDA and SCL pins on the microcontroller.

Notes: The LCD screen still needs further testing, proper resistors need to be identified to complete the I2C circuit. Initially it is recommended that we start from 4.7k ohm resistors and work our way down until the I2C circuit is functional. This will require further testing on our end. But we do not need the LCD screen in order to move on to the subsystem tests. The LCD screen will only provide the user a graphical interface on navigating the device and connecting to a WiFi access point.

5.2.5 Testing parts for the power supply

The main components for the power supply are the battery pack, capacitors, and regulators. The data sheet of the 7805 recommended to connect capacitors to the input and output of the circuit to ensure that the DC wave form would be stable. When tested by itself the regulator produced the desired voltage output. Hypothetically this should be enough to power the circuit, but the source would be volatile. Two smoothing capacitors were attached to the regulator in order to improve the output performance. 0.33uf in the input and 0.1 in the output.

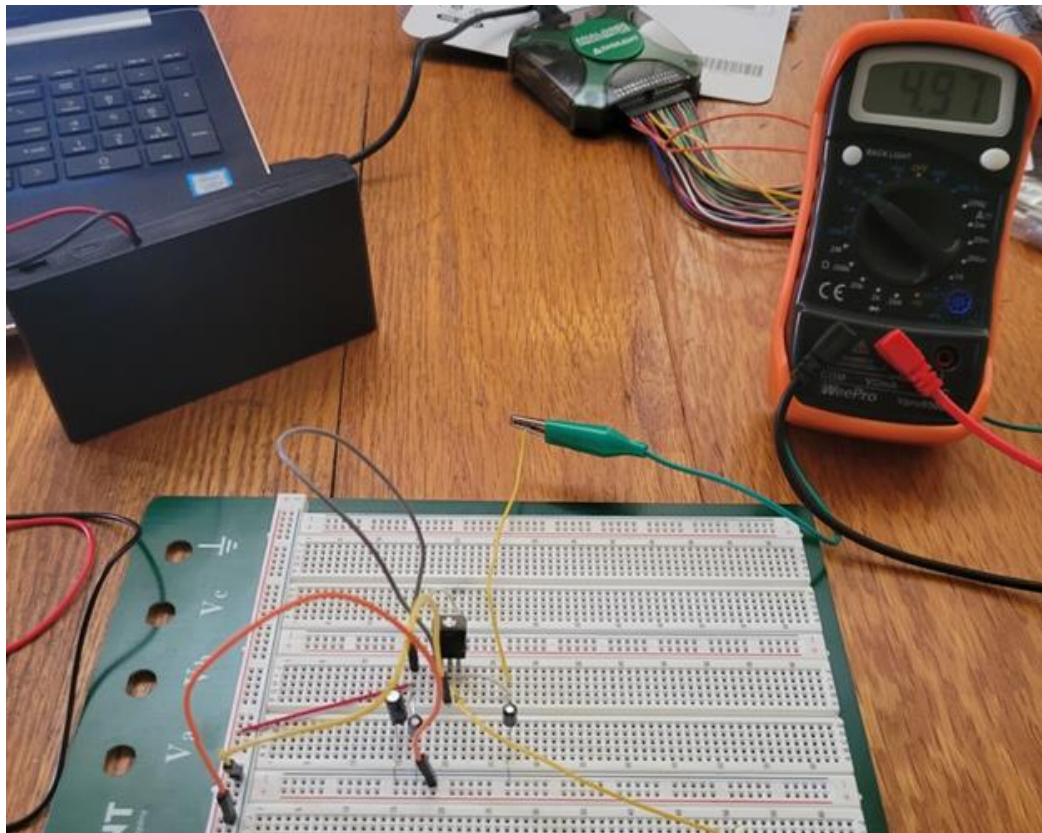

Figure 84: Testing the voltage regulator

The capacitor values were described in the datasheet and there was no copyright claim for them. It also stated that to obtain the most ideal condition for testing ceramic capacitors should be used. This was sadly not an option because of time and budgetary constraints. Electrolytic capacitors were used instead because they were more readily available and the innovation lab at the University of Central Florida did not have the desired capacitors as well. The purchased capacitors did not include a 0.33uf capacitor so in order to obtain the closest possible output a slight modification had to take place.

$$C_{\text{total}} = C_1 + C_2 + \dots + C_n$$

Figure 85: Parallel Capacitance

When connected in parallel the total capacitance of all the capacitors sums up to a total. The two values chosen were 0.22uf and 0.1uf. Both were electrolytic capacitors with a voltage limit of 50volts. When connected in parallel they will have a total capacitance of 0.32uf. This is 0.01uf short of the recommended but it should not make a major difference.

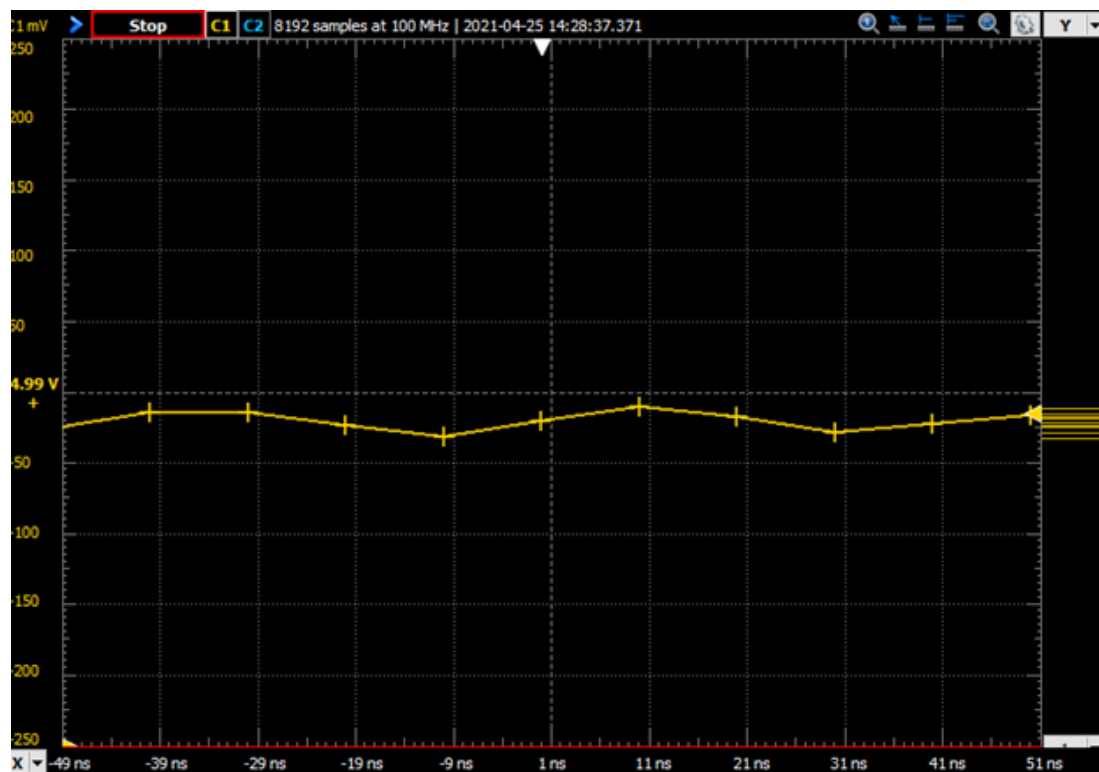

Figure 86: Output of regulator with capacitors.

After combining everything on the bread board and ensure that all pieces were properly connected the voltage was tested first. The voltage output was 4.97V which is the desired output. After connecting the circuit to an oscilloscope, the output was measured. There were slight fluctuations, but the capacitors worked as intended and modified the signal to a point where it was still a recognizable DC signal just smoothed. The output could have been properly tested if the ceramic capacitors were available. Lack of knowledge using a software to simulate an oscilloscope made the process of measuring the output more difficult than it should have been.

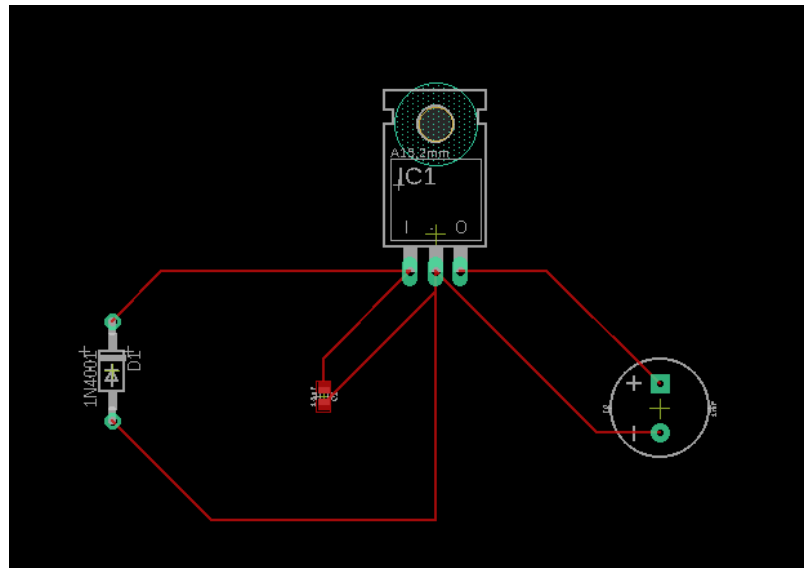

Figure 87: tentative power supply PCB

5.2.6 Testing Antennas with the Power Supply

When we started putting things together, one of the first things that we connected it to the Voltage regulator was the antennas. The antennas were tested one by one, connecting the Arduino controller and the Qwiic kit with the ID-3LA that contains a buzzer that will determine the range of each antenna. The voltage regulator was providing a total voltage of 4.95VDC, where our RFID reader requires between 2.8 to 5VDC.

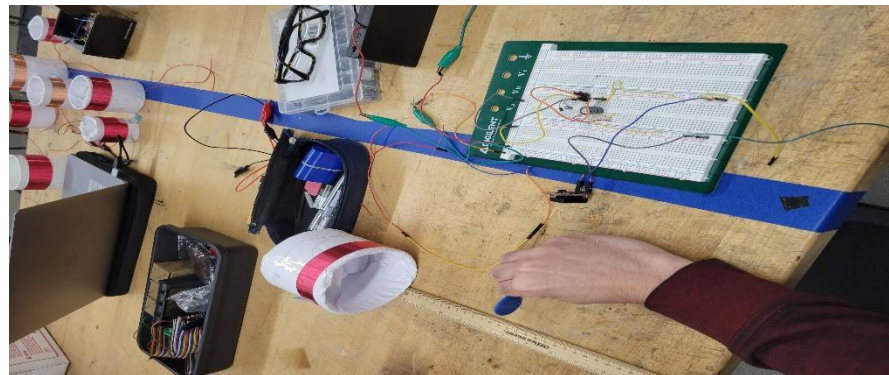

Figure 88: Voltage regulator connected to the ID-3LA and Qwiic kit

When we started testing each antenna, on the side we add a ruler to measure the range that each one of them scans the RFID tag. It is important to mention that we have some problems at first since two of the RFID tags were damaged. A table is going to be provided specifying the range of each antenna measured.

Table: 20 Antenna Testing results

AWG	Diameter Size(mm)	Range (cm)
28	68	N/A
28	86	1
28	113	5
30	68	N/A
30	86	N/A
30	113	13
32	68	N/A
32	86	8.5
32	113	3

Based on the results obtained, antennas were having pretty similar performance compared when they were connected to the computer as a power source. Looking the antennas' performance, we got another antenna that didn't scan the RFID tags, meaning that 5 out of 9 antennas are working at this point.

6 PCB Final Design

This section details the prototype schematic for the final design of the project.

6.1 PCB circuit diagram

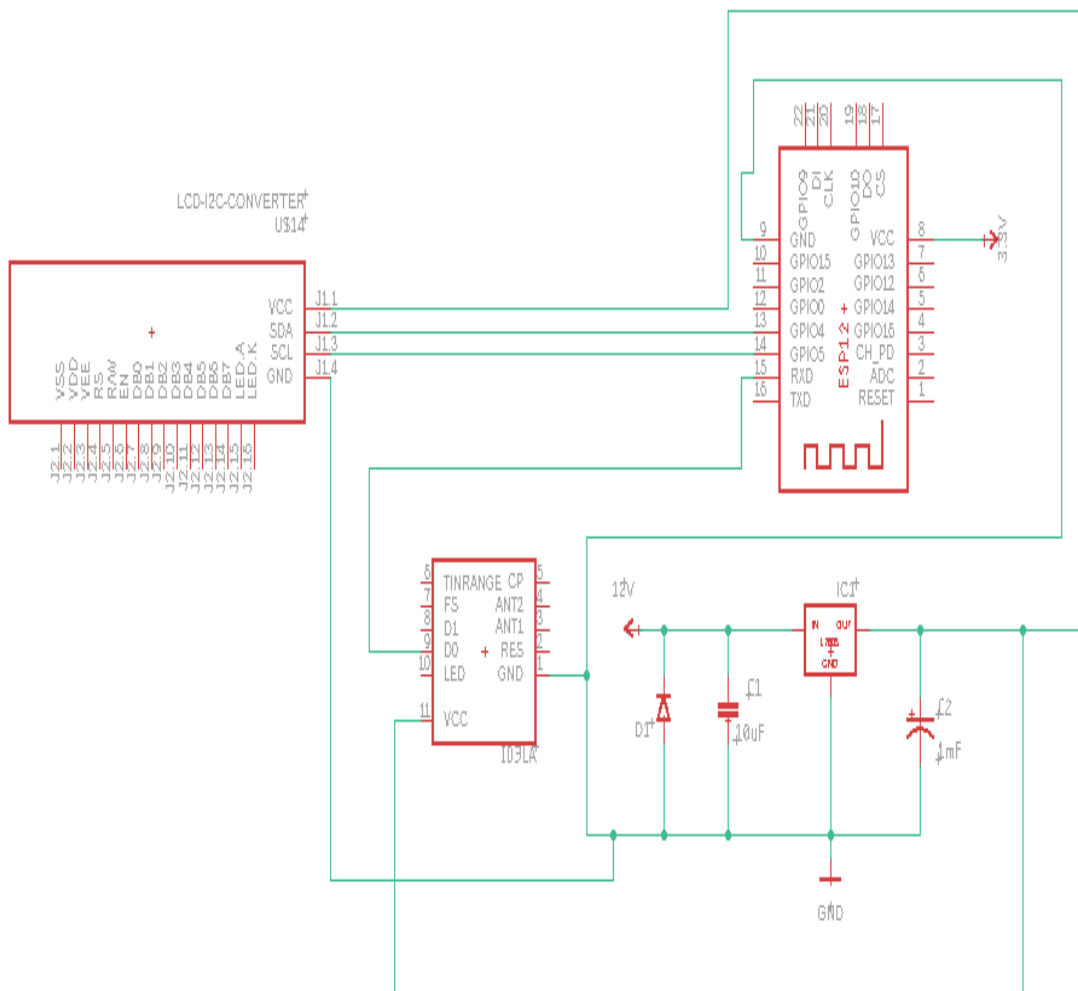

Figure 89: Schematic of PCB prototype

6.2 PCB circuit board layout

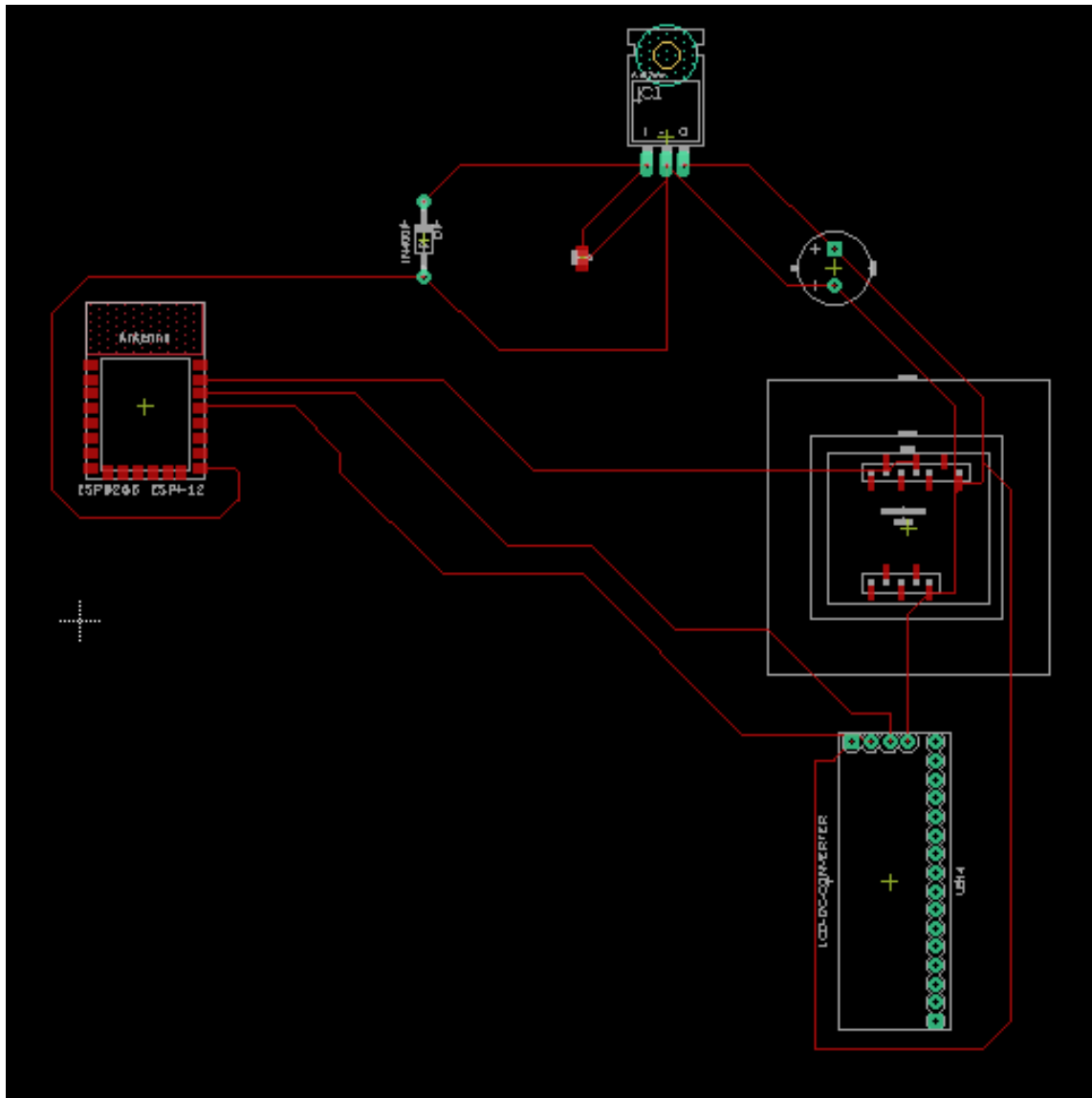

Figure 90: Board design prototype PCB

7. Administrative

7.1 Milestones

Table 21: Overview of milestones for project

Milestones					
Task	Start	End	Status	Responsible	
Senior Design I					
1 Ideas	1/12/2021	TBA	In Progress	Group 17	
2 Project Selection & Role Assignment	1/12/2021	TBA	In Progress	Group 17	
Project Report					
3 Initial Document - Divide & Conquer	1/21/2021	1/29/2021	Completed	Group 17	
Updated the to a new version after the feedback that we received from Dr. Wei					
4 Initial Document - Divide & Conquer V2	2/2/2021	2/12/2021	In Progress	Group 17	
More Information will be given as we approach the date					
4 60 Page First Draft	2/12/2021	3/15/2021	Not Started	Group 17	
More Information will be given as we approach the date					
5 100 Page report submission	3/15/2021	3/29/2021	Not Started	Group 17	
More Information will be given as we approach the date					
6 Final report	3/29/2021	4/12/2021	Not Started	Group 17	
Research, Documentation, & Design					
RFID tags	2/1/2021	TBA	Researching	Max & Efren	
How the work, and which ones we are going to get					
8 Power Distribution	2/2/2021	TBA	Researching	Max & Efren	
9 Schematics	2/3/2021	TBA	Researching	Max & Efren	
10 Raspberry Pie Data Distribution	2/4/2021	TBA	Researching	Juan & O'neal	
11 MERN Stack and Mongoose Documentation	2/4/2021	TBA	In Progress	Juan & O'neal	
12 Node JS Package Installation	2/4/2021	TBA	In Progress	Juan & O'neal	
13 Phase 1 of WebApp	2/8/2021	TBA	In Progress	Juan & O'neal	

	Initializing the server, Implementing Routes and Creating the Database				
14	Order & Test Parts	TBA	TBA	TBA	Group 17
Senior Design II					
15	Build Prototype	TBA	TBA		Group 17
16	Testing & Redesign	TBA	TBA		Group 17
17	Finalize Prototype	TBA	TBA		Group 17
18	Peer Presentation	TBA	TBA		Group 17
19	Final Report	TBA	TBA		Group 17
20	Final Presentation	TBA	TBA		Group 17

7.2 Estimated project budget & financing

Prices listed below are estimates of current online research and quotes from manufacturers. With, prices are bound to fluctuate as we get closer to the dates of purchase. Additional expenses may arise if we decided to add more features regarding hardware. As of now, we are currently not sponsored, and all costs will be inherited by the group.

Project Initial Budget: \$100/person total = \$400

Table: 22 wardrobe assistant budget

Virtual Wardrobe Assistant						
Number	Part Number	Description	Vendor	Price Per Unit	Amount	Total Estimated Price
1	MSP - 430	MSP-EXP430G2 LaunchPad	Texas Instruments	\$23.40	1	\$23.40
2		Adafruit feather HUZZAH	Adafruit	\$18.00	1	\$18.00
3		PCB Board	EAGLE	Unknown	1	Unknown
4		Plastic Clothing Notched Hangers (20)	Sharpty	\$13.99	1	\$13.99

5		12 Volt battery pack(2)	Co rode	\$4.00	1	\$8.00
6		Clothing	Self	N/A	5	0
7		DNS and Server Hosting	Go Daddy	\$49.99	1	\$49.99
8	ID-3LA	ID-3LA RFID Reader	Electromaker	\$25.99	1	\$25.99
9	EM18	EM18 RFID reader	AliExpress	\$5.99	1	\$5.99
10		Pack of batteries (20)	Duracell	\$0.75	1	\$14.99
11		24 value 500pcs capacitors	OCR	\$0.03	1	\$14.99
12		RFID tags 125kHz	Yarong RFID	\$7.98	1	\$7.98
13		15 Diodes (1N4001)	Fairchild semiconductor	\$0.20	1	\$2.98
14		Regulators (10 L7805)	C YUMU	\$6.99	1	\$6.99
15		28 AWG Enameled Copper	BNTECHGO	\$8.48	1	\$8.48
16		30AWG Enameled Copper	BNTECHGO	\$8.69	1	\$8.69
17		32 AWG Enameled Copper	BNTECHGO	\$8.69	1	\$8.69
	Total					\$219.15

7.3 Communication

To make sure our team can communicate, despite COVID-19 restrictions, we have considered different platforms to talk to each other. On these different platforms, we were able to express ourselves and share ideas to make this project to work.

7.3.1 Zoom

In the beginning stages of the project, we first used zoom to get to know each other better. At first having video communication has helpful when it came to coming up with ideas. At the end of the day, we found that using zoom was unnecessary. We first did not need video call whatsoever and having a permanent location where we can communicate ideas and reach out to each other individually become more practical. Due to the latter, we choose to migrate to discord.

7.3.2 Discord

Discord became the obvious choice after our epiphany, not only did it store previous messages, but it also allowed us to communicate in quick matter, we were able to send links and files efficiently and effectively and allowed us to simply join the discord server at anytime without dealing the hazels of Zoom. We were better at organizing and planning out the assignments due to the outstanding amount of features discord provided us.

7.3.3 OneDrive

After having so many issues importing our individual parts to Google Drive, we noticed that it was acting weird messing up margins, creating too many white spaces, making writing the document a real hassle. After careful consideration, we ended up using this online platform that contains Microsoft Word online making our lives way easier to format and to add information.

7.4 Conclusion

For eons humans have been engineering new ways to make life “easier” and save time. Inventions such as the computer and the motorized vehicle save us time when performing the corresponding tasks. Virtualizing the wardrobe is no different. Utilizing RFID technology can physically be used to keep track of closet inventory. Being a group of young college students, we all shared the same view on this topic. Keeping an organized wardrobe will save a person hour in the long run. This would create more opportunities like working on hobbies and spending time with family. The overall technology of RFID provides us with a safe and cost-effective method of keeping track of the inventory. Our product displays the versatility of radio frequency technology and how it can be applied throughout the

common household. In summary, being able to devote more time into other tasks instead of hand managing a closet inventory is completed through our wardrobe inventory management system.

Appendix A - Copyright Permissions

Copyright permission granted for ID-3LA schematic

O'Neal Thomas - Copyright permission request Inbox x 📄 🖨 📧

 **O'Neal Thomas** Tue, Apr 6, 9:38 AM (8 days ago) ☆
Hello, I am an undergraduate student studying at the University of Central Florida in the U.S. I am currently in my senior design course and I would like to ask

 **Wendy Jiang** <wendy@id-innovations.com> 12:35 AM (8 hours ago) ☆ ↩ ⋮
to me ▼

Hi O'Neal

Thanks for writing to us.

No problem to use it if you are using ID-3LA for your design course.

Please let us know if you have any question.

Best regards

Wendy Powell

NEW release:
Low power series: ID-3/12/20LA- LP draws 1mA Maximum current
Ultra low power ID-3/12/20- uP draws 5uA @3v current
<http://www.id-innovations.com/htdocs/Modules%28non%20write%29.htm>
[See Module testing video on Youtube](#)

Appendix B - Datasheets

AWG	Diameter [Inches]	Diameter [mm]	Area [mm ²]	Resistance [Ohms / 1000 ft]	Resistance [Ohms / km]	Max Current [Amperes]	Max Frequency for 100% skin depth
0000 (4/0)	0.46	11.684	107	0.049	0.16072	302	125 Hz
000 (3/0)	0.4096	10.40384	85	0.0618	0.202704	239	160 Hz
00 (2/0)	0.3648	9.26592	67.4	0.0779	0.255512	190	200 Hz
0 (1/0)	0.3249	8.25246	53.5	0.0983	0.322424	150	250 Hz
1	0.2893	7.34822	42.4	0.1239	0.406392	119	325 Hz
2	0.2576	6.54304	33.6	0.1563	0.512664	94	410 Hz
3	0.2294	5.82676	26.7	0.197	0.64616	75	500 Hz
4	0.2043	5.18922	21.2	0.2485	0.81508	60	650 Hz
5	0.1819	4.62026	16.8	0.3133	1.027624	47	810 Hz
6	0.162	4.1148	13.3	0.3951	1.295928	37	1100 Hz
7	0.1443	3.66522	10.5	0.4982	1.634096	30	1300 Hz
8	0.1285	3.2639	8.37	0.6282	2.060496	24	1650 Hz
9	0.1144	2.90576	6.63	0.7921	2.598088	19	2050 Hz
10	0.1019	2.58826	5.26	0.9989	3.276392	15	2600 Hz
11	0.0907	2.30378	4.17	1.26	4.1328	12	3200 Hz
12	0.0808	2.05232	3.31	1.588	5.20864	9.3	4150 Hz
13	0.072	1.8288	2.62	2.003	6.56984	7.4	5300 Hz
14	0.0641	1.62814	2.08	2.525	8.282	5.9	6700 Hz
15	0.0571	1.45034	1.65	3.184	10.44352	4.7	8250 Hz
16	0.0508	1.29032	1.31	4.016	13.17248	3.7	11 k Hz
17	0.0453	1.15062	1.04	5.064	16.60992	2.9	13 k Hz
18	0.0403	1.02362	0.823	6.385	20.9428	2.3	17 kHz
19	0.0359	0.91186	0.653	8.051	26.40728	1.8	21 kHz
20	0.032	0.8128	0.518	10.15	33.292	1.5	27 kHz
21	0.0285	0.7239	0.41	12.8	41.984	1.2	33 kHz
22	0.0254	0.64516	0.326	16.14	52.9392	0.92	42 kHz
23	0.0226	0.57404	0.258	20.36	66.7808	0.729	53 kHz
24	0.0201	0.51054	0.205	25.67	84.1976	0.577	68 kHz
25	0.0179	0.45466	0.162	32.37	106.1736	0.457	85 kHz
26	0.0159	0.40386	0.129	40.81	133.8568	0.361	107 kHz
27	0.0142	0.36068	0.102	51.47	168.8216	0.288	130 kHz
28	0.0126	0.32004	0.081	64.9	212.872	0.226	170 kHz
29	0.0113	0.28702	0.0642	81.83	268.4024	0.182	210 kHz
30	0.01	0.254	0.0509	103.2	338.496	0.142	270 kHz
31	0.0089	0.22606	0.0404	130.1	426.728	0.113	340 kHz
32	0.008	0.2032	0.032	164.1	538.248	0.091	430 kHz
33	0.0071	0.18034	0.0254	206.9	678.632	0.072	540 kHz
34	0.0063	0.16002	0.0201	260.9	855.752	0.056	690 kHz
35	0.0056	0.14224	0.016	329	1079.12	0.044	870 kHz
36	0.005	0.127	0.0127	414.8	1360	0.035	1100 kHz
37	0.0045	0.1143	0.01	523.1	1715	0.0289	1350 kHz
38	0.004	0.1016	0.00797	659.6	2163	0.0228	1750 kHz
39	0.0035	0.0889	0.00632	831.8	2728	0.0175	2250 kHz
40	0.0031	0.07874	0.00501	1049	3440	0.0137	2900 kHz

AWG Table

Appendix C – References

- #370201, Member, et al. “RFID Reader ID-12LA (125 KHz).” *SEN-11827 - SparkFun Electronics*, www.sparkfun.com/products/11827.
- #370201, Member, et al. “RFID Reader ID-12LA (125 KHz).” *SEN-11827 - SparkFun Electronics*, www.sparkfun.com/products/11827.
- #673974, Member, et al. “RFID Reader ID-3LA (125 KHz).” *SEN-11862 - SparkFun Electronics*, www.sparkfun.com/products/11862.
- “.NET vs Elixir: What Are the Differences?” *StackShare*, stackshare.io/stackups/dot-net-vs-elixir.
- 262588213843476. “Rfiddemo.ino.” *Gist*, gist.github.com/jsгарvin/888d97b9a258511bc980.
- “6 Things That Can Affect An RFID System's Performance.” *6 Things That Can Affect An RFID System's Performance | Serialio.com*, www.serialio.com/support/6-things-can-affect-rfid-systems-performance.
- “6 Things That Can Affect An RFID System's Performance.” *6 Things That Can Affect An RFID System's Performance | Serialio.com*, www.serialio.com/support/6-things-can-affect-rfid-systems-performance.
- Ada, Lady. “Adafruit Feather HUZZAH ESP8266.” *Adafruit Learning System*, learn.adafruit.com/adafruit-feather-huzzah-esp8266/pinouts.
- Ada, Lady. “Adafruit Feather HUZZAH ESP8266.” *Adafruit Learning System*, learn.adafruit.com/adafruit-feather-huzzah-esp8266/pinouts.

- Ada, Lady. “Adafruit Feather HUZZAH ESP8266.” *Adafruit Learning System*, learn.adafruit.com/adafruit-feather-huzzah-esp8266/power-management.
- Ada, Lady. “Adafruit Feather HUZZAH ESP8266.” *Adafruit Learning System*, learn.adafruit.com/adafruit-feather-huzzah-esp8266/power-management.
- Ada, Lady. “Adafruit Feather HUZZAH ESP8266.” *Adafruit Learning System*, learn.adafruit.com/adafruit-feather-huzzah-esp8266/power-management.
- Ada, Lady. “Adafruit Feather HUZZAH ESP8266.” *Adafruit Learning System*, learn.adafruit.com/adafruit-feather-huzzah-esp8266/using-arduino-ide.
- Ada, Lady. “Adafruit Feather HUZZAH ESP8266.” *Adafruit Learning System*, learn.adafruit.com/adafruit-feather-huzzah-esp8266/using-arduino-ide.
- “The Advantages and Disadvantages of Active and Passive RFID Technologies.” *Altium*, resources.altium.com/p/advantages-and-disadvantages-active-and-passive-rfid-technologies.
- Ali.RashidiAli.Rashidi, et al. “How to Read from a Usb Rfid Reader?” *Stack Overflow*, 1 Dec. 1962, stackoverflow.com/questions/22516812/how-to-read-from-a-usb-rfid-reader.

- “Angular vs React vs Vue - My Thoughts.” *Academind*, Academind, academind.com/tutorials/angular-vs-react-vs-vue-my-thoughts/.
- Baisden, Andrew. “Creating MERN Stack Applications (2020).” *DEV Community*, DEV Community, 31 July 2020, dev.to/andrewbaisden/creating-mern-stack-applications-2020-4a44.
- “The Collaboration Platform for API Development.” *Postman*, www.postman.com/.
- Contributor, TechTarget. “What Is Automatic Identification and Data Capture (AIDC)? - Definition from WhatIs.com.” *SearchERP*, TechTarget, 4 Nov. 2010, searcherp.techtarget.com/definition/Automatic-Identification-and-Data-Capture-AIDC.
- Daityari, Shaumik. “Angular vs React vs Vue: Which Framework to Choose in 2021.” *CodeinWP*, VertiStudio, 15 Mar. 2021, www.codeinwp.com/blog/angular-vs-vue-vs-react/.
- DigitalOcean. “Apache vs Nginx: Practical Considerations.” *DigitalOcean*, www.digitalocean.com/community/tutorials/apache-vs-nginx-practical-considerations.
- “Download the Latest Version of Robo 3T.” *Robo 3T | Free, Open-Source MongoDB GUI (Formerly Robomongo)*, robomongo.org/.
- F5, Owen Garrett of. “NGINX vs. Apache: Our View of a Decade-Old Question.” *NGINX*, 14 Jan. 2021, www.nginx.com/blog/nginx-vs-apache-our-view/.

- “Fastify vs. Express.” *Educative*, www.educative.io/edpresso/fastify-vs-express.
- “The Fun, Simple, Flexible JavaScript Test Framework.” *Mocha*, mochajs.org/.
- Ganssle, Jack. “A Designers Guide to RFID.” *DigiKey*, Convergence Promotions LLC, 2 May 2013, www.digikey.com/en/articles/a-designers-guide-to-rfid.
- “Heroku vs AppEngine: UpGuard.” *RSS*, www.upguard.com/blog/heroku-appengine.
- *Heroku*, dashboard.heroku.com/apps.
- Hinz, Paul. “RFID VS BARCODES: Advantages and Disadvantages Comparison.” *Adaptalift*, www.adaptalift.com.au/blog/2012-05-01-rfid-vs-barcodes-advantages-and-disadvantages-comparison#:~:text=Barcodes%20have%20no%20read%2Fwrite,more%20easily%20reproduced%20or%20forged.
- “How RFID Works & Antenna Design: EAGLE: Blog.” *Eagle Blog*, 2 Feb. 2021, www.autodesk.com/products/eagle/blog/rfid-works-antenna-design/.
- *Invalid Request*, www.digikey.com/en/articles/a-designers-guide-to-rfid :
- “Managed MongoDB Hosting: Database-as-a-Service.” *MongoDB*, www.mongodb.com/cloud/atlas.

- Mark Otto, Jacob Thornton. "Bootstrap." *Bootstrap · The Most Popular HTML, CSS, and JS Library in the World.*, getbootstrap.com/.
- "Nginx vs Apache: Which Web Server Is the Best? (2021 Edition)." *Kinsta*, 26 Mar. 2021, kinsta.com/blog/nginx-vs-apache/.
- "Node.js vs Asp.net: Find Out The 5 Best Differences." *EDUCBA*, 22 Mar. 2021, www.educba.com/node-js-vs-asp-net/.
- "Node.js vs ASP.NET: Which One Is A Better For Web Development?" *ESparkbiz*, 22 Mar. 2021, www.esparkinfo.com/node-js-vs-asp-net.html.
- P, Pieter. *A Beginner's Guide to the ESP8266*, ttapa.github.io/ESP8266/Chap02%20-%20Hardware.html.
- Petrik, Louis. "I Built the Same API With Fastify, Express & Bare Node.js. Here Are the Differences." *Medium*, JavaScript in Plain English, 9 Oct. 2020, javascript.plainenglish.io/fastify-express-benchmark-4c4aebb726d6.
- "POWER SUPPLY BASICS." *Wavelength Electronics*, Wavelength Electronics, 25 Mar. 2021, www.teamwavelength.com/power-supply-basics/.
- "Runtime System." *Wikipedia*, Wikimedia Foundation, 9 Apr. 2021, en.wikipedia.org/wiki/Runtime_system.
- "Series and Parallel Capacitors: Capacitors: Electronics Textbook." *All About Circuits*, www.allaboutcircuits.com/textbook/direct-current/chpt-13/series-and-parallel-

- “Zener Diode as Voltage Regulator Tutorial.” *Basic Electronics Tutorials*, 30 Mar. 2020, www.electronics-tutorials.ws/diode/diode_7.html.