

# 120 Page First Semester Document

April 3, 2020

## **Bottom Feeder**



A remotely operated underwater vehicle that de-risks aquatic exploration and assists in locating and recovering personal effects.

### **University of Central Florida**

Department of Electrical Engineering and Computer Science

Dr. Samuel Richie

#### **Group 2**

John Cope	Computer Engineering	<a href="mailto:jcope@knights.ucf.edu">jcope@knights.ucf.edu</a>
T Davis	Computer Engineering	<a href="mailto:t_davis@knights.ucf.edu">t_davis@knights.ucf.edu</a>
Sarah Reim	Electrical Engineering	<a href="mailto:sreim1@knights.ucf.edu">sreim1@knights.ucf.edu</a>
Tyler Rose	Electrical Engineering	<a href="mailto:tyler.rose@knights.ucf.edu">tyler.rose@knights.ucf.edu</a>

# Table of Contents

## Table of Contents

### List of Figures

<b>1.0 Executive Summary</b>	<b>12</b>
<b>2.0 Project Summary</b>	<b>13</b>
2.1 Project Goals	13
2.2 Project Milestones	14
2.3 Functionality	15
2.4 Existing Products	16
2.4.1 Metal Detecting	16
2.4.2 Object Retrieval	18
2.4.3 Video Capturing	20
2.5 Engineering Requirements	21
2.6 Project Operation	23
2.7 Bill of Materials & Project Budget	24
2.8 Safety Warnings and Hazards	26
2.9 House of Quality	26
2.10 Hardware Diagram	28
2.11 Software Diagram	29
<b>3.0 Project Research</b>	<b>31</b>
3.1 Propulsion	31
3.1.1 Motor Layout	31
3.1.2 Motor Selection - Pre-built Options	34
3.1.3 Motor Selection - Building our own	35
3.1.4 Build Using a DC Motor	35

3.1.5 Build Using a Bilge Pump Cartridge	36
3.1.6 Motor Comparisons	36
3.1.7 Propulsion Conclusion	37
3.2 Cameras	38
3.2.1 Mono Video	38
3.2.2 Stereo Video	38
3.2.3 Fixed Camera	39
3.2.4 Gimbal Camera	39
3.2.5 Omnidirectional video standards	39
3.2.6 Camera technologies	40
3.2.7 Infrared Filtering	41
3.2.8 Imaging Sensors	42
3.2.8.1 Omnivision 5647	42
3.2.8.1 IMX219	42
3.2.8.1 AR0251	42
3.2.9 Camera Comparisons	43
3.2.10 Camera Selection	44
3.3 Positional Feedback	45
3.3.1 BNO055 from Bosch Sensotec	45
3.3.2 BerryIMU from Ozzmaker	45
3.3.3 9DoF Razor IMU Mo from SparkFun	45
3.3.4 Positional Feedback Conclusion	46
3.4 Metal Detection	46
3.4.1 Beat Frequency Oscillation	46
3.4.2 Very Low-Frequency Detectors	47
3.4.3 Pulse Induction	48

3.4.4 Best Detector For Our Project	48
3.5 Power	50
3.5.1 Powering The Surface System	51
3.5.2 Surface System Battery	52
3.5.3 Power over Ethernet	54
3.5.4 Surface Station Power Alternatives	57
3.5.5 Powering The ROV	58
3.5.6 ROV Battery Power	58
3.6 Tether	61
3.6.1 Tether Criteria	64
3.6.2 Our Tether	65
3.7 Depth sensing	67
3.7.1 LPS33HW Pressure sensor	68
3.7.2 Autex Pressure Transducer	68
3.7.3 Pressure Sensor Comparisons	69
3.7.4 Pressure Sensor Selection	69
3.8 Geiger Counter	69
3.9 Lights	70
3.9.1 Purchasable Options	71
3.9.2 Making Our Own	71
3.9.3 Comparison and Selection	72
3.10 Operator View	74
3.11 Control System	75
3.12 Housing	75
3.12.1 Permanent Enclosures	75
3.12.2 Resealable Enclosures	76

3.12.3 PVC Scaffolding	76
3.13 Electrical Feedthroughs	76
3.13.1 Wet Mate Connectors	77
3.13.2 Dry Mate Feedthroughs	77
3.13.3 Permanent Feedthroughs	77
3.13.4 Feedthrough selection	78
3.14 Object Retrieval	78
3.15 Home Base	80
3.16 Sonar	81
3.17 Main Onboard Computer	83
3.17.1 Raspberry Pi 4	83
3.17.2 Nvidia Jetson Nano	83
3.17.3 Libre Computer ROC-RK3328-CC Renegade	84
3.17.4 ASUS Tinker Board	84
3.17.5 UDOO BOLT	85
3.17.6 Onboard Computer Conclusion	85
3.18 Microcontroller	86
3.18.1 MSP430G2553	87
3.18.2 ATmega328P	87
3.18.3 SAMD51	87
3.18.4 Microcontroller Conclusion	87
3.19 Motor Driver	88
3.19.1 MDD3A	88
3.19.2 L298N	89
3.19.3 Motor Driver Conclusion	89
4.0 Standards and Constraints	<b>89</b>

4.1 Realistic Project Constraints	89
4.1.1 Impacts from the COVID-19 Global Pandemic	90
4.1.2 Economic Constraints	91
4.1.3 Environmental Constraints	91
4.1.4 Social and Political Constraints	92
4.1.5 Legal Constraints	92
4.1.6 Health and Safety Constraints	93
4.1.7 Manufacturability Constraints	93
4.1.8 Sustainability Constraints	94
4.1.9 Ethical Constraints	95
4.1.10 Application Constraints	95
4.2 Project Standards	95
4.2.1 Battery Standards	96
4.2.2 PCB Standards	96
4.2.3 Bluetooth 5	97
4.2.4 H.264 AVC	98
4.2.5 360 Video Formats	98
4.2.6 RoHS Standards	99
4.2.7 CAT-6 Standard	99
4.2.8 I2C	100
4.2.9 UDP/IP	100
4.2.10 STL	100
4.2.11 Power over Ethernet Standards	101
5.0 Project Design	<b>102</b>
5.1 Hardware Design	102
5.1.1 Pressure Sensor Design	102

5.1.2 IMU Design	103
5.1.3 LED Illumination Design	103
5.1.4 Submersible Embedded Design	104
5.1.5 Surface computing Design	105
5.1.6 Motor Driver Design	106
5.1.7 Power Supply Design	107
5.1.8 Metal Detector Circuit Design	109
5.2 Software Design	111
5.2.1 Omnidirectional Video Processing Design	112
5.2.2 Microcontroller Code Development	113
5.2.3 ROS system development	114
5.2.4 Class Diagram	114
5.3 Printed Circuit Board (PCB)	116
5.3.1 Schematic and PCB Software	116
5.3.2 PCB Manufacturing and Soldering	117
5.3.3 PCB Design	117
5.4 System Housing Design	117
5.4.1 Materials	119
5.4.2 Modeling Software	119
6.0 Testing	<b>119</b>
6.1 Component Testing	120
6.1.1 Pressure Sensor Testing	120
6.1.2 IMU Testing	120
6.1.3 Power Testing	121
6.1.4 Bluetooth Testing	121
6.1.5 Head Mounted Display Testing	121

6.1.6 Metal Detector Testing	122
6.1.7 Geiger Counter Testing	122
6.1.8 Thruster Testing	123
6.1.9 Camera Testing	126
6.2 Prototype Testing	127
6.2.1 Hardware Testing	127
6.2.2 Software Testing	128
7.0 Conclusion	<b>128</b>
<b>8.0 Appendix</b>	<b>130</b>
8.1 References	130
8.2 Permission	133



# List of Figures

Figure 1: JW Fishers RMD-1 attached to the SeaLion-2	17
Figure 2: Deep Trekker Two-Function Grabber Arm	17
Figure 3: Diving Scooper	18
Figure 4: Gladius Mini by Chasing Innovation	18
Figure 5: House of quality	19
Figure 6: Block Diagram of system with task assignments	19
Figure 7: ROV Software Flowchart	20
Figure 8: ROV Surface Station Flowchart	20
Figure 9: 6DOF Motor Layout 1	27
Figure 10: 6DOF Motor Layout 2	27
Figure 11: 6DOF Motor Layout 3	29
Figure 12: Five Motor design	29
Figure 13: Four motor design	30
Figure 14: Three motor design	30
Figure 15: Thruster available on Amazon	31
Figure 16: 1100 GPH Bilge Pump	31
Figure 17: The Waveshare IMX219-200, featuring IMX219 and a 200° FoV lens	32
Figure 18: BNO055 IMU	32
Figure 19: Beat Frequency Oscillation	32
Figure 20: Kingdetector Metal Detector MD-4030 Search Coil	32
Figure 21: High-Level Power Flow	33
Figure 22: MightyMax ML18-12	33

Figure 23: Network switch and standards for PoE output	34
Figure 24: TP-Link TL-PoE150S	34
Figure 25: Turnigy 11	34
Figure 26: Fathom ROV Tether	34
Figure 27: Steel wire strength member	34
Figure 28: Stranded Cat 6 Ethernet cable	34
Figure 29: Mightyohm Geiger Counter V1	35
Figure 30: Cree XLamp XP-L-665-1	35
Figure 31: The dry mate RJ45 cable gland that will be used to connect the tether	38
Figure 32: test items for ROV sensor testing and retrieval	38
Figure 33: Mechanical arm vs	44
Figure 34: Home base block diagram	44
Figure 35: Nvidia Jetson Nano	46
Figure 36: TI LaunchPad using MSP430G2553	46
Figure 37: The connections between the Jetson, the MSP430 and discrete components	47
Figure 38: Application schematics from the L298	47
Figure 39: The resultant schematic of the motor driver subassembly	49
Figure 40: The voltage regulation for the low power electronics systems	49
Figure 41: The high power motor supply	51
Figure 42: RLC oscillator circuit using the 555 timer	51
Figure 43: This pulse counting circuit provides a SPI interface to measure frequency	53

Figure 44: Breadboard prototype of metal detection circuit	53
Figure 45: An example 200° field of view image available for processing	54
Figure 46: Class Diagram	54
Figure 47: ROV Design made of PVC with metal detector	56
Figure 48: A design featuring geometries available locally and thruster configuration noted in figure 13	56
Figure 49: Motor Test Bench	60
Figure 50: Design 1	60
Figure 51: Design 2	62
Figure 52: Design 3	62
Figure 53: Jetson Nano Camera Testing Case	64
Figure 54: Jetson Nano Testing Case Bracket	64
Figure 55: An omnidirectional, equirectangular image of a suburban yard	66

# 1.0 Executive Summary

Living in Florida, our lives are deeply entwined with the water. Many of our hobbies, our recreations, our professions, and our stories touch the waves at some point or another. Florida's key location at the southeast point of the nation, and its peninsular geography combine to create an environment that draws visitors from around the globe for reasons spanning business and pleasure.

Our motivation in creating a submersible robot is to alleviate some of the drawbacks to our watery way of life. Jewelry, keys, and keepsakes are liable to be lost at beaches. Repair and maintenance of boats and submerged structures can be delayed if a tool or critical component slips out of a technician's hand and buries itself in the silt below. We are creating an ROV capable of finding and recovering objects from sandy bottomed waterways. This will be achieved through the use of a metal detector and vacuum assisted shovel for an aquatic robotics platform.

Control and interaction with the device will be facilitated by a camera system linked with a head mounted display. With a low-latency connection, users will be able to look around from the robot's perspective, independent of machine orientation. The machine will be aware of its orientation and position and actively stabilize itself with thrusters. The operator will be able to use an off the shelf gaming controller to direct the general movement of the machine, while the operating system will manage the motors to accomplish that locomotion. The systems will also support headlights.

In addition to metal detection, the ROV will be equipped with other sensors to improve its functionality as well as helping gather information about the surrounding waters. Functional sensors would include those that would enable our bot to maintain proper orientation, depths, and speeds while it traverses through the water. Information gathering sensors will be added to better monitor the encompassing body of water's health.

The ROV will have an array of thrusters for movement. The controller on board the submersible will be able to use motion sensors to stabilize itself, allowing the operator to control the machine behind a layer of abstraction. Through a controller, the operator will command the machine to perform translation and rotation operations. Within the submersible, it will manage whichever thrusters may have to work together to perform those operations faithfully.

In general, not only is it much safer to deploy an unmanned vehicle under water but, given that ROV's can stay underwater longer than your average diver, it's also more time efficient. Our vision is to eliminate the need for human divers to enter our waterways to retrieve lost valuables and gather information, making for much more effective subaquatic exploration.

## **2.0 Project Summary**

Human underwater exploration always involves some amount of risk. Scuba divers can get stuck in tight spaces or can get their airline caught on rocks or coral. Scuba divers who surface too quickly can experience decompression sickness and have to spend an extended period of time in a hyperbaric chamber. Small personal submarines can develop catastrophic leaks, lose power, or simply run out of air. Our project aims to de-risk underwater exploration by removing the human from the underwater environment. By developing and using an underwater submersible vehicle we can perform tasks such as recording video, detecting metal objects, and object retrieval all without risking human life.

### **2.1 Project Goals**

Even the most basic underwater remotely operated vehicles can cost thousands of dollars while providing no more than a camera feed. Our goal is to develop and create an entire ROV system that is capable of underwater exploration and video recording, which also includes advanced features such as 3D video, metal detection, object retrieval, and potentially more. We want to accomplish all of this while also keeping our budget below a thousand dollars.

We will design the entire system of the ROV. This includes the ROV itself and the surface station which will receive and process information from the ROV, output that information to the user in a live feed, and take user inputs from a controller. The surface station will then need to relay that information down to the ROV and tell it how the operator wants it to move. The ROV will be responsible for recording 3D video and processing it into a usable video format that can be sent through a tether to the surface station. The ROV will also need to respond to controller inputs received from the base station and distribute power to the motors appropriately. Stable movement is important for video recording, so the ROV will be equipped with an inertial measurement system and a control program which keeps the ROV stable while underwater. Video quality is one of the most important features for any ROV. Special consideration for this will be

needed when selecting the cameras, designing the placement for the cameras, and designing the placement and intensity of the underwater lighting.

The entire system needs to be intuitive and easy to control. While we all are only a few months away from having a degree in engineering, you shouldn't need one in order to operate the submersible vehicle. The ROV should be ready to work out of the box, with no complicated setup protocols needed. The only thing we should expect the user to do is turn the device on and throw it into the water that they want to explore.

## **2.2 Project Milestones**

The entire Senior Design experience is a very time intensive one. Because of how much time is required to do a good job it is important that a schedule be created early and that everyone in the group is on the same page concerning what all needs to be done and when it needs to be done by. In table 1 below we list the import milestones and the expected schedule for this entire project.

For Senior Design I the important dates given by the class are the dates that documentation is due. Divide and Conquer I and II set out to define the scope of the project that we are doing, and serve to formalize our project idea into something that our advisor can approve of and give feedback on. The three rough drafts focus mainly on the research required for this project, including research on current products that serve similar purposes, potential parts to be used in the prototype, relevant legal considerations, and any standards that are used when designing and building the prototype.

Senior Design II is mainly concerned with the building and testing of the actual prototype. For this stage of the class we need to have the working prototype built and coded as early as possible. The earlier we have a working prototype, the earlier we'll be able to start testing it and make any modifications as needed. The eventual final end date doesn't leave any room for delays, so it is important that we stay on schedule, as depicted in table 1 and get things done as quickly as possible.

Table 1: Project Milestones

<b>Senior Design I</b>	
Task	Due Date
Form Group	1/10/2020
Project Idea	1/24/2020
Divide and Conquer 1	1/31/2020
Divide and Conquer 2	2/14/2020
<b>Milestone 1 - Finalize Project Idea and Requirement Specifications</b>	
Order SBC, Cameras	3/09/2020
Sixty Page Rough Draft	3/09/2020
Order Motor For Testing	3/31/2020
One Hundred Page Rough Draft	4/02/2020
Order Additional Parts	4/13/2020
Final Document	4/13/2020
<b>Milestone 2 - Finished Research and Produced Final Document</b>	
<b>Senior Design II</b>	
Working code for ROV	5/02/2020
Working base station	5/30/2020
Finish Building Prototype	6/10/2020
Finish Testing Prototype	6/31/2020
<b>Milestone 3 - Working Prototype</b>	
Final Presentation	TBD
<b>Milestone 4 - Graduation</b>	

## 2.3 Functionality

This project is a combination of software and hardware functionality, and these are described below in table 2.

Table 2: The hardware and software functionality of the ROV

Software Function:
Provide a real time video interface to the ROV
Provide real time control over all ROV features
Show operator relevant metal detection data regarding location and strength.
Maintain ROV position and orientation autonomously using sensor information.
Alert operator if the ROV is descending beyond tolerable limits.
Hardware Functionality:
Intuitive and ergonomic controller for ROV.
Live video feed from ROV to HMD.
Thrusters must be able to move ROV at 5 knots.
A metal detector must detect a crescent wrench ten centimeters away from the sensor.
The Geiger counter must report activity of surrounding materials or water.

## 2.4 Existing Products

There are only a handful of submersible ROVs available for purchase in today's market, and each one typically offers only a couple of features. The most common feature for these systems is high quality video that is streamed to a surface system (or home base). Some products have other added sensors to tell you the temperature of the water or find fish, but ROVs with metal detector capabilities tend to be much more expensive and rare. We want to build a submersible ROV that has a metal detector, a tool for picking up objects, and a high quality or stereo video camera all with an affordable price tag. We are also looking into the option of an omnidirectional camera system that would allow the user to turn their head in any direction and see all around the ROV via the headset.

### 2.4.1 Metal Detecting

One of the features we want to have on our ROV is a small metal detector. Currently, ROVs with metal detectors are expensive. JW Fishers made an ROV, see *figure 1*, and a separate metal detector that can be attached to their ROV or potentially other ROVs. This metal detector is fantastic as it can detect ferrous and nonferrous metals that are buried up to a distance of 1.5 meters [1]. Another



thing pointed out in their article is that it was made to function without producing a false positive for metal inside the ROV that it is attached to. The biggest issue with a high-class metal detector like this is that the pricing of this product precludes its selection from student and hobbyist projects. The metal detector itself runs for \$12,995 and the ROV shown in *figure 1* for \$29,995 currently.



*Figure 1: JW Fishers RMD-1 attached to the SeaLion-2*  
Reprinted with permission, from [1]

The type of customer that JW Fishers is looking for is likely to be a very specific type of customer who will use this equipment in more industrial-sized operations. For our project, we need to find something significantly cheaper, but even other companies that sell metal detectors made for ROVs still charge a high price (typically over \$1,000). We want to create a prototype that would be more suitable for the average ocean explorer or inspector. The average person is not going to be able to afford expensive equipment so we will need to come up with something more cost effective. We want to build or modify a much simpler metal detector that will just give some added functionality to our ROV without adding a large cost to the entire system. We should be able to build or modify a simpler metal detector that will cost around \$50 to add to our ROV. Depending on our design and purchase options of metal detectors, this may have a large impact on the overall design for the housing of our project. A large metal detector would use

up more power and, therefore, we would need a larger ROV and a bigger battery to drive this feature.

## 2.4.2 Object Retrieval

Another one of the functions that we want our ROV to have is the ability to grab or pick up objects. When exploring underwater, you may detect something worth picking up (like a bottle cap, a small coin, or maybe a golden nugget). Without some sort of arm or scooper, you would have to suit up and dive down to pick up these objects by hand. By attaching a mechanical arm to the ROV, you won't have to get in the water for something small. One type of arm that we found in our research was a rotatable claw developed by Deep Trekker, found below in *figure 2*.



*Figure 2:* Deep Trekker Two-Function Grabber Arm  
Reprinted with permission, from [2]

This type of solution is great because it is an optional attachment to add to an ROV, and it has two simple functions. The arm has a claw that can open or close, as well as rotate. This is something that we would like to implement as it could be used to move things out of the way. The major issue with Deep Trekker's solution is that it is too expensive for what it does. It can rotate and open/close, but they

are charging \$1500 for their arm. It is also relatively large compared to the ROV itself. This means that the maneuverability may suffer by having such a large attachment. We should be able to make our own grabber arm solution out of much cheaper materials and save a lot of money on this feature for our ROV.

Another option typically used by divers is a scooping device. Divers will pass over an area with their metal detector, then they will scoop up a small area of sand that the metal detector picked something up in. If they scan the area again and the detector does not sound off, it is safe to say they scooped up the object. An example of one of the types of scoopers used can be found in *figure 3*.



*Figure 3: Diving Scooper*

Reprinted with permission pending, from [3]

For something like this, we could use a smaller scooper that we could build or buy for our ROV. We would then need to decide if we wanted the scooper to be simply mounted to the ROV or if we wanted to make a more sophisticated system to allow us more complex movements besides driving the ROV into the sand. If we are able to make precise enough movements with the ROV, then we could even use a static arm that can open/close and a static scooper in conjunction to pick things up or throw things around during an expedition.

### 2.4.3 Video Capturing

Video capturing is the most important function of the submersible ROV. The user needs to be able to see in order to do inspections, look for treasure, or to take pictures and video. Almost all of the ROVs used today have a single 4K camera built-in. Even if the ROV comes with a headset for the pilot to wear, they are typically looking at a single captured image. Many of the current ROVs don't need stereo video capturing because the user only needs to take pictures. For those cases it makes sense to have one nice camera and not two or more. Most of the affordable ROVs out there look very much like the Gladius Mini, pictured in *figure 4*.



*Figure 4: Gladius Mini by Chasing Innovation*  
Reprinted with permission, from [4]

They have one camera that points in front of the ROV with two small lights beside it. Having a single camera may be enough for common applications, but it may not be enough for our ROV. If we are able to set up two cameras, it opens up many new possibilities. Having two front-facing stereo cameras would allow the pilot to have better depth perception while operating the ROV. This would be very useful to our project because we will have features that we will operate close to objects in the environment. For example, with the grabber arm attached to the ROV, you would want to have good depth perception in order to make more

precise movements. With a metal detector feature, you will want to have a better idea of how close you are to the object or area you are scanning.

The other way we are considering using two cameras is by setting two cameras back-to-back inside of a clear sphere to provide omnidirectional video. By using two wide angle cameras in this way, we could create almost 360 degrees of vision (minus the parts blocked by the seams in the housing or parts blocked by the frame). This would allow us to do interesting things like allow the user to rotate their headset and look around from the ROV's perspective. Not only would this make the visuals quite stunning, but it could save battery power and aid inspection by allowing the freedom to look around without the need to drive the motors and physically move the ROV.

## **2.5 Engineering Requirements**

The engineering requirements define the specific properties and features that the final product should have. They serve as the contract between the customer and the engineers designing the product. Even though we act as both the customer and the design team for this project, it is still important that an explicit set of requirements be created from the start, so that everyone is on the same page and that the product gets designed with the same goals in mind. The Engineering requirements consist of detailed and measurable features, each one needs to have a clear and quantifiable way to test in order to ensure that the requirements are being met. Below is the detailed list of our engineering requirements. They are broken up into sections based on each individual component. This way it'll be clear if the component being tested has passed all relevant tests.

Stereo camera:

- Provide omnidirectional visual feedback to an operator above water
- 1080p video resolution for real time video feedback and video recording

Battery:

- 1 hour runtime (standard usage)
- Can be recharged by the user without needing tools.

Metal detector:

- Has a maximum detection range of at least 10 centimeters
- Has a maximum depth rating of 10 meters

#### Head Mounted Display:

- Capable of displaying 1080 video feed from cameras underwater
- Able to look around in 360 degrees
- Shows feedback from onboard sensors
- Battery charge displayed

#### Handheld controller:

- Controls all horizontal translational, vertical translation, and rotational movement.

#### Onboard Controller:

- Receives input instruction from handheld controller and sends power to the appropriate thrusters and ballast tank.
- Receives data from inertial measurement unit and other sensors
- Transmits sensor data to headset
- Emergency float system in case cable disconnects from ROV

#### Sensors:

- 3 axis gyroscope with  $\pm 2000$  degrees per second dynamic range
- 3 axis accelerometer with  $\pm 4g$  acceleration range
- 3 axis magnetometer  $\pm 1000\mu T$  magnetic field range
- Depth gauge accurate to 5mm
- Geiger counter accurate to  $\pm 20\%$

#### Collection Device:

- Can collect an item under 6"x6"x6" and up to 5 pounds

#### Housing:

- Water resistant up to maximum depth of 10 meters

#### Motors:

- Capable of moving the ROV at 5 knots forwards and backwards
- Can turn the ROV completely around in 3 seconds
- Can change the pitch by 30 degrees in 1 second

## 2.6 Project Operation

This project has several layers of abstraction and human interaction, and benefits from a central user's guide for operation. The piloting of this device requires that the operator understand several aspects of system constraint, and the importance of respecting these constraints.

To begin a piloting session, the system must be prepared ahead of time, and these preparations should be verified in a pre-departure check. Failure to verify that the following systems are functioning properly could result in total loss of the submersible system or other considerable expenses due to damage. It should be verified that the electronics enclosure is fully sealed, and any external fasteners or bolts are tightened fully. All batteries should be fully charged before disembarking, as a power failure can result in the need for ROV recovery, which may then only become possible by reeling in the tether. However, there is no guaranteed success if such an unfortunate event were to take place. That being said, the user must be very mindful of the ROV's condition before launch.

After a pre-departure check, the pilot should set up and turn on the surface station, followed by the ROV booting up and showing signs of life. After verifying that everything is running smoothly, the user may then release the tether and submerge the vehicle into the water. It is highly recommended that a second person minds the homebase and takes special care of the tether during operation to avoid tangles and snags.

Verifying that there is plenty of space to operate, the pilot is ready to operate the headset and controller. They should be sure to place the controller within reach and the head mounted display gently over their heads. The headset should be fastened in place, and the pilot should now be viewing a live feed of video directly from the ROV. The controller will be used to navigate the ROV through the water.

After the user is done with exploration, proper retrieval and storage of the ROV must take place. The pilot must bring the vehicle back to the surface and either they or their crew must reel in the tether, being cautious of kinks and entanglement. Once the ROV is above surface, it should be inspected for any sort of damage before being dried and stored.

## 2.7 Bill of Materials & Project Budget

Underwater exploration is an inherently expensive endeavor to undertake. Getting things working on land is relatively easy, but when you try to make electronics work underwater you have to account for long term waterproofing, intense compressive forces, corrosion, and figuring out a way to send and receive signals from something that is underwater to something located on the surface. In our research into current products on the market we had a difficult time finding products priced below \$1000 dollars. For professionally built ROVs, such as the BlueROV2 from Blue Robotics, can easily cost anywhere between three thousand and five thousand dollars [5]. We do not have any form of corporate sponsorship so we are forced to see what we are able to build for much less than what ROV companies are charging for their products. With this all in mind, our goal is to keep the final production cost of our prototype below one thousand dollars. Our estimated budget is shown below in table 3.

*Table 3: Estimated Project Budget and Financing*

Item	Cost
Camera	\$125
Raspberry Pi	\$40
Nvidia Jetson Nano	\$100
Battery	\$30
Handheld Controller	\$40
Inertial Measurement Unit	\$30
Motors	\$100
Metal Detector	\$100
Tether	\$100
FPV Headset	\$120
Frame	\$50
Printed Circuit Board	\$30
Electronics Enclosure	\$20
Microcontroller	\$2.00
<b>Total</b>	<b>\$885</b>



Our current bill of materials can be found in table 4 below. These represent current components under development by the team in pursuit of the functioning ROV.

*Table 4: Bill of Materials*

Part	Description	Price	QTY	Ext. Price
<b>Total:</b>				<b>\$792.59</b>
IMX219-200	Camera	\$34.85	2	\$69.70
Jetson Nano	SBC	\$99.00	1	\$99.00
MSP430G2553	Microcontroller	\$1.84	1	\$1.84
L298N	Motor Driver	\$4.86	4	\$19.44
Bilge Pump Cartridge	Thruster	\$30.09	4	\$120.36
Cree XLamp XP-L LED	Lights	\$6.99	2	\$13.98
Turnigy 3200mAh 3S 30C LiPoly Pack	Battery	\$22.89	1	\$22.89
Turnigy 14.8V 5 Amp-hr	Battery	\$42.51	1	\$42.51
Raspberry Pi	SBC	\$41.99	1	\$41.99
BNO055	IMU	\$11.16	1	\$11.16
PS4 DualShock 4	Bluetooth Controller	\$46.96	1	\$46.96
Pressure transducer 100 PSI	Pressure Sensor	\$23.80	1	\$23.80
tp-link TL-POE150S	PoE Injector	\$24.99	1	\$24.99
MightyMax ML18-12	Surface Station Battery	\$22.99	1	\$22.99
Oculus Rift Dev Kit 2	Headset	\$150.00	1	\$150.00
Waterproof CAT 6 - 50 feet	Tether	\$27.99	1	\$27.99
MD-4030	Metal Detector	\$52.99	1	\$52.99

## **2.8 Safety Warnings and Hazards**

The biggest concern that's going to be associated with our product is the electrical components being exposed to water. Electrocution is a big safety hazard and should be avoided at all costs. It's important to make sure our equipment is up-to-date and properly tested/maintained before submerging it in water. Other safety warnings and hazards may include:

- Avoiding other divers in the water while deploying because light and noise can interfere with a diver's senses [6]
- ROV propellers or thrusters getting caught in the umbilical or coming in contact with a person
- We will be spending quite a bit of time in Florida's summer heat testing our product, so it's important to stay hydrated and to use sunscreen

## **2.9 House of Quality**

The house of quality shows relationships between engineering requirements and marketing requirements. It also shows the relationships between different engineering requirements, allowing for more informed decision making when deciding between different options. Engineering decisions always involve trade-offs and this diagram will help add a central point around which the team can communicate when deciding what to include or exclude, and what areas of design could be optimized further and what systems may be culled in the process.

























	Engineering Reqs.	Detector Sensitivity	Power Efficiency	Case Strength	Video Quality	Maneuverability	Cost
Minimize + Maximise - Pos Correlation  Neg Correlation 							
Marketing Reqs		+	+	+	+	+	-
Cost	-						
Physical Range	+						
Battery Life	+						
User Interface	+						
Detection Quality	+						
Target		$\geq 10\text{cm}$	$\leq 100\text{ watts}$	IP 68 @ 10m	1080 HD	5 knots	$\leq \$1000$

Figure 5: House of quality

## 2.10 Hardware Diagram

The hardware for this entire ROV system is broken up into a surface station and the ROV itself. These two parts are connected using a tether which allows for data and power to be transferred between the two systems. The surface station consists of a computer, a headset, a controller, and a power supply. The computer runs the code that receives controller input from the controller, sends that input through the tether to the ROV, and also receives and processes the video and sensor data coming through the tether from the ROV. The surface station then takes this processed video and sensor information and displays it to the user through the headset.

The ROV consists of everything that is underwater, including the onboard computer, the thrusters, a metal detector, a grabbing device, lights, sensors, and a power system. The onboard computer is responsible for collecting and encoding the camera feed and sending it, along with sensor information, to the surface station. The ROV needs to take any controller inputs that it receives and apply the correct power and direction to the appropriate motors. The ROV needs to be powered in some way. Some power will be sent through the tether using Power over Ethernet, the rest will need to be supplied to the motors using an on board battery. The individual components of the system were divided among the four group members based on our majors. The computer engineering majors will deal mainly with the coding of the single board computers and embedded systems. The electrical engineering majors will be focusing on power distributions and data communication. The hardware diagram itself is given below in *figure 6*. As more components are researched and purchased the diagram will change to reflect that.

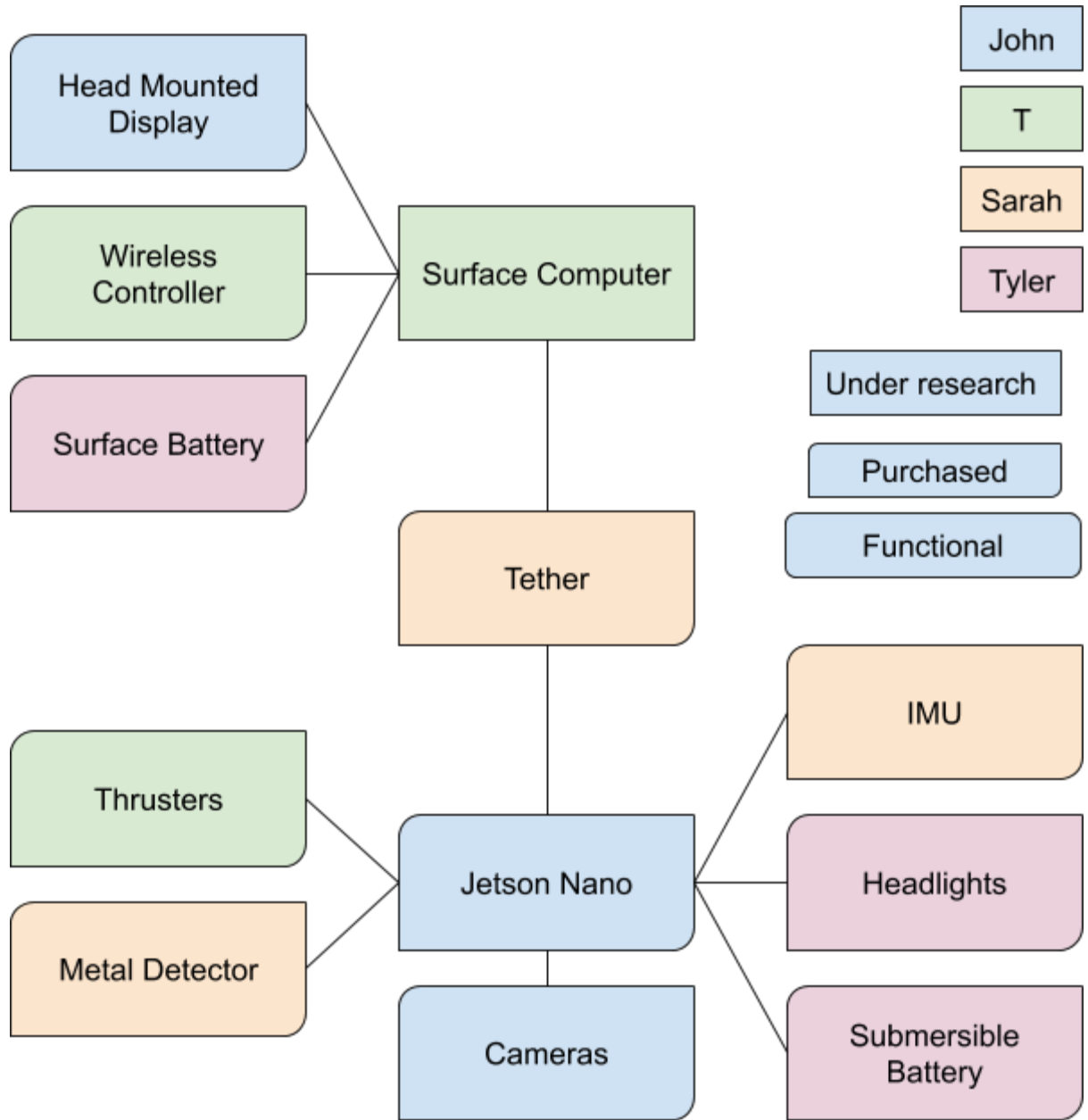

Figure 6: Block Diagram of system with task assignments

## 2.11 Software Diagram

The software that controls the ROV is developed using the Robot Operating System (ROS) on Ubuntu Linux. The software diagrams are broken down into two parts, *figure 7* shows the software diagram for the system on the ROV itself, whereas *figure 8* shows the software diagram for the system on the surface station. The ROV will need to initialize its cameras and sensors, connect to the surface station, and then send video and sensor information while also receiving

any and all controller input from the surface station. The ROV will then take that controller input and determine what motors need to be turned on, what direction they need to spin, and how much power they need to get. The surface station will need to connect to the headset and the controller, and establish a communication link with the ROV. Once connected it will need to receive the video stream from the ROV, display it on the headset, and send all controller inputs to the ROV.

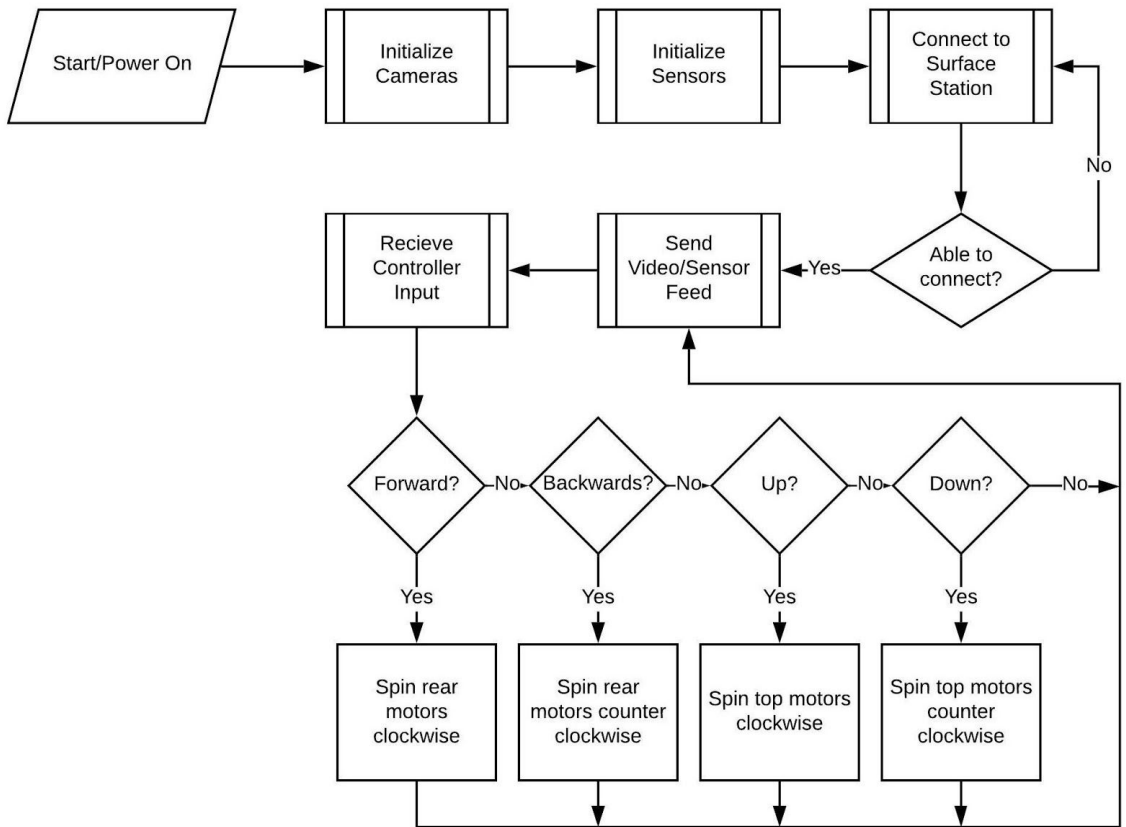
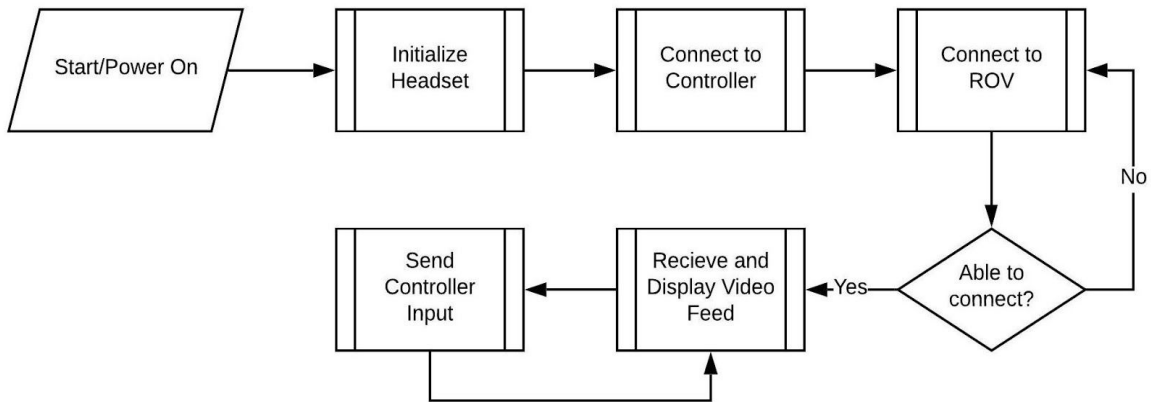

Figure 7: ROV Software Flowchart



*Figure 8: ROV Surface Station Flowchart*

## 3.0 Project Research

All of the research done for the individual components used in our ROV are provided in this section. For every system that comprises the eventual end project, multiple different hardware aspects were researched and evaluated based on different criteria such as the price, how well it will work, and the availability of supporting documentation. At the end of each subsection is a conclusion where we discuss which option we eventually ended up using and why we chose that option.

### 3.1 Propulsion

ROVs need a way to move around underwater. Without it, your ROV will drift around aimlessly controlled only by the current of the water. ROVs use electric motors to spin a propeller in the water. The important things to consider in designing the propulsion system is where the motors will physically be, and how powerful they are.

#### 3.1.1 Motor Layout

The first step to figuring out the design of your thrusters is figuring out what kind of control you want to have of the ROV. Underwater it is possible to move your ROV in six different degrees of freedom. Three of them are translational (forward/backward, left/right, up/down), and three of them are rotational (yaw, pitch, roll). Many different motor orientations are possible, but if you want the

full six degrees of freedom you'll likely need to use at least six different motors. Below are two possible six degree of freedom motor orientations.

In *figure 9* motors 1 and 2 provide forward and backward movement, and yaw rotation. Motors 3, 4, and 5 handle up and down movement and pitch, and motor 6 gives you left and right movement. Motors 3 and 4 will give the ROV roll.

The layout in *figure 10* has a more symmetrical layout, with the motors 1, 2, 3 and 4 all working together for forwards/backwards movement, left/right movement, pitch, and yaw. Motors 5 and 6 handle up and down movement along with roll. The downside to this layout is that a lot of the energy used by the motors is wasted. In order to go forward four motors have to spin at the same time, but each one is only using half of its energy to push forward. The rest is used to counteract the horizontal forces from the other three motors. The layout in *figure 11* is similar to the design in *figure 10*, but it has extra motors for upwards and downwards movement. This design would only be used if the ROV was expected to lift heavy loads.

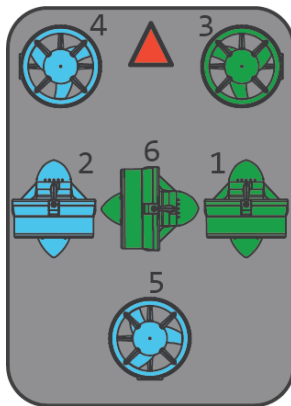

*Figure 9: 6DOF Motor Layout 1*  
Reprinted with permission, from [7]

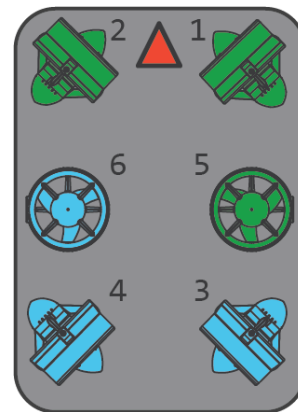

*Figure 10: 6DOF Motor Layout 2*  
Reprinted with permission, from [7]



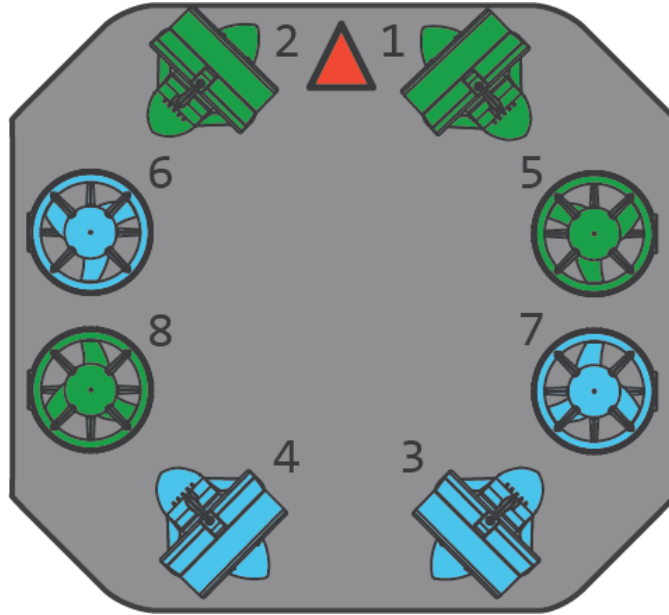
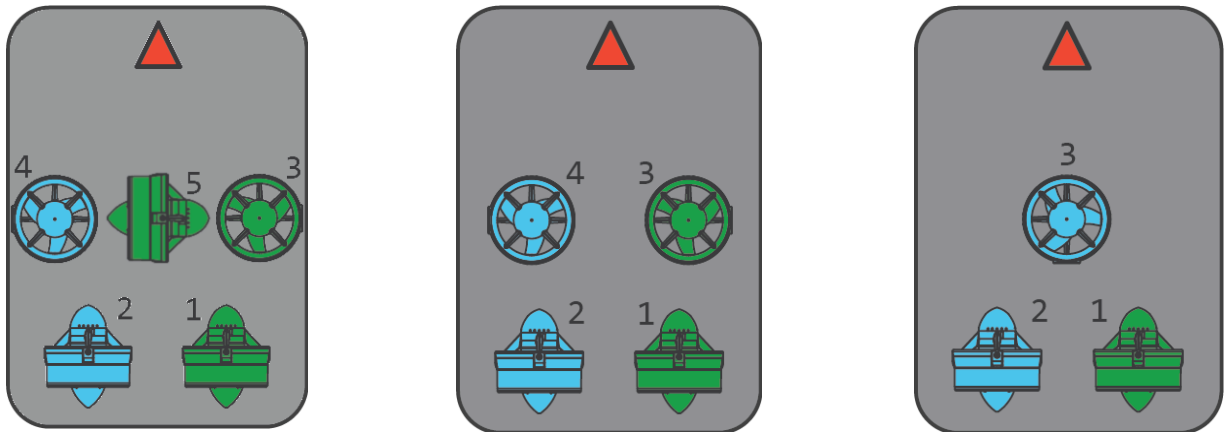

Figure 11: 6DOF Motor Layout 3  
Reprinted with permission, from [7]

If six degrees of freedom isn't necessary then designs with less thrusters can be used in order to save on cost, weight, and energy requirements. The design in *figure 12* uses two motors for forwards and backwards movement along with yaw rotation, two motors for up and down movement and roll, and one motor for lateral movement. This design does not offer any pitch control. The design in *figure 13* drops the motor for lateral movement and over provides for movement forwards/backwards, up/down, and yaw and roll rotations. The last design in *figure 14* uses only three motors and cuts out the second vertical thruster from *figure 13*. This leaves the potential ROV with only three degrees of freedom of movement, forwards/backwards, up/down, and yaw rotation.



*Figure 12: Five Motor design Reprinted with permission, from [7]*    *Figure 13: Four motor design Reprinted with permission, from [7]*    *Figure 14: Three motor design Reprinted with permission, from [7]*

The motor layout we will be using will be the four motor design from *figure 13*. This design has the best compromise between degree of control, cost, simplicity, and energy usage. [7]

### **3.1.2 Motor Selection - Pre-built Options**

T100 Thruster from Blue Robotics - Cost \$119 each

This thruster is able to produce 5 pounds of thrust and is specially designed for use in ROV applications. The motor itself is a three phase brushless electric motor that is sealed and protected using an epoxy coating to seal it inside a UV resistant polycarbonate injection molded plastic. The motor uses high-performance plastic bearings instead of steel bearing because steel bearings will rust in saltwater. [8]

Smart Thruster from Seadrone Pro - Cost \$190 each

Able to generate 5.5 pounds of force. The motor itself is a custom sensorless brushless motor that can monitor its current, voltage, RPM and temperature in real time. The included smart control system can accommodate for battery voltage drops after the battery has been in use. [9]

VS Thruster from Copenhagen Subsea - Cost \$250 each

This thruster is specially designed for underwater applications and has only one moving part, an inner ring which rotates with propeller blades attached to it. All molded parts are solid, with no sealing needed and no air or oil on the inside. The bearings are lubricated using seawater and the hubless propeller means there is a low risk of entanglement. This thruster is capable of providing up to 55 pounds of force. [10]

RC Boat Thruster 12-24V from Amazon - Cost \$35.99 each

This Amazon listing provides little more than a picture of the product in question. Unfortunately most all listings on popular online shopping websites have this same flaw. There is no description outlining important information like power draw, force produced, or even the size of the thruster.



*Figure 15: Thruster available on Amazon*  
Reprinted with permission pending, from [11]

### **3.1.3 Motor Selection - Building our own**

All pre-built specially designed thrusters for ROV applications have one glaring weakness, they are all prohibitively expensive. Some options are available from sites such as Amazon and Ebay that are more accessibly priced, but they lack any sort of documentation. One way to get around these limitations is to build our own thruster. We found two different methods online on how to build an underwater thruster, one using a DC brushless motor that is typically used for remote controlled airplanes, and one using the motor from a submersible bilge pump.

### **3.1.4 Build Using a DC Motor**

The first build uses a DT700 brushless motor which is available from HobbyKing for \$13.91 [12], a 3D printed nozzle set, and some epoxy resin for waterproofing. The first step is to partially disassemble the motor and seal the wires with epoxy.

This will keep the wires from deteriorating over time which could cause the motor or the controller to burn out. Next the motor needs to be modified so that it can handle the extra load from moving through water instead of air. The shaft of the motor needs a deeper hole drilled into it so that the set screws hold the shaft securely. Once the motor is ready, all that is left is to place the motor into the 3D printed housing and screw everything together. The guide for this particular build claims a measured thrust of over 10 pounds, which is twice as much as the thrust claimed from the \$119 thruster from Blue Robotics. [13]

### **3.1.5 Build Using a Bilge Pump Cartridge**

The second build uses a Johnson Pump Cartridge from a submersible bilge pump and 3D printed thruster housings and propellers. A 1000 gallon per hour pump cartridge costs \$33.72 [14]. This design doesn't require any additional sealing or modification to the motor. You simply place the bilge pump cartridge into the thruster mount, attach the mount to your ROV, and then attach the propeller to the shaft of the bilge pump cartridge. The designer of this build doesn't give numbers for pounds of thrust, but they do say that the 1000 gallon per hour pump cartridge was sufficient for their needs. [15]

### **3.1.6 Motor Comparisons**

The comparison table for the previously discussed thruster options is given below in table 5. The professionally prebuilt options allow us to buy a motor we know will work, but the price tag means that most of our budget will go towards propulsion. Cheaper prebuilt options could provide an out of the box solution, but all options that were found lack proper documentation on how much power they'll draw and how much force they are able to produce. The few online reviews that these cheaper options have also cite reliability concerns. Waterproofing a standard DC motor gives us a wide range of DC motors to choose from, and is much more affordable than the prebuilt options. However, waterproofing an electric motor can be very challenging and we are worried about how long these water proofing measures would last for. There is also no way to know how much force we will get out of the thruster until it is built and tested. The bilge pump conversion method is also much cheaper than the prebuilt options. Bilge pumps also come in a professionally designed waterproof housing, so there aren't any reliability concerns with the water proofing method. The selection of available bilge pumps is limited however, with there only being a handful of options

ranging between a flow rate of 500 gallons per hour to 1100 gallons per hour. Along with the DC motor conversion, the bilge pump conversion does not have any proper documentation, so extensive testing must be done to judge how effective the motor design is.

*Table 5: Thruster Option Comparisons*

Method	Pros	Cons
Professionally prebuilt options	<ul style="list-style-type: none"> <li>Specifically designed to work underwater with an ROV.</li> </ul>	<ul style="list-style-type: none"> <li>Prohibitively expensive.</li> </ul>
Cheap prebuilt options	<ul style="list-style-type: none"> <li>Affordable</li> </ul>	<ul style="list-style-type: none"> <li>Poor documentation</li> <li>Negative reviews</li> </ul>
DC motor conversion	<ul style="list-style-type: none"> <li>Cheapest option</li> <li>Large selection of potential motors.</li> </ul>	<ul style="list-style-type: none"> <li>Waterproofing can prove difficult</li> <li>Reliability concerns</li> <li>No documentation</li> </ul>
Bilge pump conversion	<ul style="list-style-type: none"> <li>Cheaper than prebuilt options</li> <li>Motor is already waterproofed</li> </ul>	<ul style="list-style-type: none"> <li>Limited selection</li> <li>No documentation</li> </ul>

### **3.1.7 Propulsion Conclusion**

We decided on using a bilge pump that was found on Ebay and then adapting it to serve our needs. One was bought at first for test purposes. A picture of the bilge pump that was purchased for testing purposes is shown below in *figure 16*. To adapt this pump into a thruster the blue part and the white part need to first be removed from the red pump cartridge. Next the impeller needs to be removed and a properly sized propeller needs to be put in its place. Finally, a mount needs to be designed for the motor so that it can be attached to the frame of the ROV.



*Figure 16: 1100 GPH Bilge Pump*

## **3.2 Cameras**

Typical ROV applications have a single, fixed, viewport in the front of the vehicle. This fixed camera's captured image is relayed to a view screen at the base station. Other video solutions allow for more immersive experiences, at the cost of more expensive equipment for video capture and processing. Video feeds can also be transmitted via analog or digital communication means, and a variety of compression techniques can be applied to this data.

### **3.2.1 Mono Video**

This is the simplest option for video capture and transmission. A single, front facing camera is very common on existing ROV products and solutions. The total frame captured is presented to the viewer, with no image data being captured and not displayed, as is the case with omnidirectional video discussed below.

### **3.2.2 Stereo Video**

Stereo video transmission is very similar to mono video transmission, but with most systems simply being duplicated. Static stereo video allows for a viewer to observe a scene with realistic depth of field information usually lost to mono

video. Anaglyphic video transmission allows for great savings in storage space and transmission bandwidth, at the sacrifice of color quality. This system overlays two perspectives on one another, while offsetting and tinting the disparate streams, and requires the viewer to wear color filtering lenses to separate each eye's proper perspective.

### **3.2.3 Fixed Camera**

A camera rigidly mounted to the frame of the robot provides an easy to implement viewpoint that not only serves to allow exploration of the environment, but also intuitively demonstrates to the user of the devices the orientation of the ROV. This is the most commonly implemented mounting scheme in commercially available devices. ROVs, being neutrally buoyant and quite maneuverable, a fixed camera does not inhibit exploration as much as it might on a terrestrial device.

### **3.2.4 Gimbal Camera**

Mounting a camera on a gimbal is a common method of overcoming orientation limitations in machines that have a distinct “top” and “bottom” as wheeled, walking, or aerial vehicles are commonly constrained. A linkage of motorized joints allows an operator to look around the world independent of overall device orientation. This, paired with head mounted displays, provides an immersive experience for many first-person-view racing drones and other robots where total environment immersion is an important factor.

### **3.2.5 Omnidirectional video standards**

Storing omnidirectional video is an ongoing point of development in computer science and entertainment. A major format is the equirectangular projection. It is created by "unfolding" the sphere of the world visible by the camera. The lines of longitude extending from the upper and lower poles of the sphere also touch the top and bottom of a rectangular frame of a video or photograph. The latitudinal lines of the sphere then become horizontal lines across the image. This mapping is straightforward to implement in its creation, as it very cleanly correlates two angular displacements for a given pixel value to two cartesian displacements. A drawback of equirectangular projection is the excessive distortion of the poles in storage and transmission, which can lead to degradation of quality on playback.

The color value of the exact pole of the view sphere technically maps to all pixels horizontally at the top and bottom of the frame.

Alternatives to equirectangular projection usually involve mapping the view sphere onto a platonic solid, such as a cube, and unfolding that solid's net. This avoids the excessive pinch and distortion earlier described, but is more computationally complex to map values from a source to this format.

Stereo omnidirectional video requires two or more of these mapped video streams, with one for each eye's viewpoint. Capturing multiple omnidirectional videos can require a large array of cameras and considerable post processing power. Omnidirectional video, when viewed through a HMD, allows the user to explore a recorded environment freely and intuitively. This can be a challenge for stereo omnidirectional video however, because yaw, pitch and roll movements by the user may not map directly to camera offsets and angles, creating a dissonance in experience.

Many of the considerations of omnidirectional video capture and playback need not be considered by creators of video games or other virtual environments. The ease with which a scene can be rendered from multiple points of view simultaneously allows for any perspective the player so desires without a dramatic increase in processing or storage. Furthermore, the amount of video generated by these systems is much less than stored or broadcast omnidirectional video, as the scene is rendered on the fly, and objects outside the viewing frustum are culled without computing visual data. For scenes that are to be recorded and played back after the fact, all viewing angles must be captured at once, stored, and loaded for each viewer, allowing the viewer to explore at their own leisure.

### **3.2.6 Camera technologies**

There are many web-cam style solutions for digital video capture that use USB or USB3 to transfer their images to the computer. This allows for many cameras to be connected to a single device, although with additional layers of software abstraction between the image sensor and the application running on the computer using the image.

Analog video solutions will encode the captured image in NTSC video format. This format of signal can be readily viewed by many TVs or smaller view screens. Once this signal is generated, overlaying other images on it requires matching sync with the video signal's pulses, or capturing the analog signal into a digital signal for software processing. Similar equipment is required for splicing



multiple signals into one video screen. A benefit of NTSC is that multiple video streams can exist on a single coaxial cable. Limiting the number of conductors required for a signal is a great design consideration in ROVs, where conductor count and complexity shows itself in costs of tether and feedthroughs.

The MIPI-CSI communications protocol allows for very rapid deposition of camera image data into a computer, but is more technologically limiting, as compared to USB, in terms of the hardware needed to directly connect these imaging sensors to the computing device. The MIPI-CSI standard is a proprietary one, and is restricted in terms of distribution. Access to the standard is limited to members of the MIPI Alliance, and membership costs begin at \$4,000 and can reach upwards of \$40,000 for corporate and influential partner membership in the alliance. Developing custom hardware using the MIPI-CSI standards is outside of the scope of independent students and hobbyists without significant reverse engineering efforts. It is stated that the MIPI-CSI interface isn't suited for long term cable transmission, as the standard requires a ribbon cable. It is the interest of the engineer to create a system for processing the image data nearby to the camera. This can take the form of an embedded computing system that handles all image processing at the site of the camera, or could take the form of a signal processor unit that can convert the video feed into a format more suited for long term transmission and processing at a distance.

The PixyCam offers an easy to incorporate object tracking solution for the device. If the ROV is to follow and film another device, or an aquatic creature, this would be a great feature to have. If the ROV is to maintain a relative position to an undersea feature, perhaps a boat hull for inspection, the PixyCam's data output can assist the positioning system of the ROV to counteract drift due to currents. These features are not mutually exclusive with other vision systems. A camera-based feedback to a closed loop control system can be implemented in parallel with a high quality video solution for ROV operations and remote viewing.

### **3.2.7 Infrared Filtering**

Camera sensors are not strictly limited to photoelectric transduction in the visible spectrum. Photons of many wavelengths can excite the photosensitive elements of these devices. This has become a feature in some systems and a drawback that must be compensated for in others. Infrared filtering is an option on many off-the-shelf camera imaging units. Sensors with filtering can produce images that more closely resemble what humans see, but those that lack IR filters can

show odd glows from heat sources, television remotes, and even change how the sky or clouds look due to IR scattering in the atmosphere differently than visible light. Cameras without IR filters are used in security systems alongside IR sources, creating a system of illumination and image capture that is totally outside the visible spectrum. This allows for security cameras to be deployed in areas where a human-visible illumination source would disturb the normal operation of the space, or spoil a covert nature of surveillance intended.

Water absorbs a great deal more IR light than the atmosphere, so the amount of incident light provided by the sun decreases below the surface of the water.

## **3.2.8 Imaging Sensors**

If MIPI-CSI as the format and communication standard is selected for the video input devices, there are still several options of sensor and sensor manufacturer that operate over the MIPI-CSI interface.

### **3.2.8.1 Omnivision 5647**

The Omnivision 5647 provides a 5 megapixel sensor with dimensions of 2592 x 1944, available through two lanes of MIPI-CSI. It captures light through a 1/4” sensor, and is able to stream a 1080p video at 30fps, and smaller resolutions at a faster rate, and report colors at either an 8 or 10 bit depth. This sensor is widely available broken out on a development board with a variety of lens mounts, and was widely distributed for use with early Raspberry Pi computers.

### **3.2.8.1 IMX219**

The IMX219 is an 8 megapixel sensor produced by Sony. The sensor is 1/4 inch format, and single lane MIPI. It is able to produce a 1080p feed at 30 frames per second. The color depth is reported with 10 bit depth. This is widely distributed with carrier boards and sold under the general title of Raspberry Pi Camera V2.1. This sensor is also packaged with a variety of lens mounts and fixed mount lenses with a varied selection of fields of view.

### **3.2.8.1 AR0251**

At the highest end of camera modules considered, the AR0251 sensor is very capable of capturing a wide dynamic range in a scene, and worked exceptionally well with low noise in low light scenarios. The sensor is a 1/2.5 inch module,

containing a 5 megapixel array. It has the same pixel dimensions as the Omnivision 5647 sensor, but doubling the length and width of the cell allows for four times the light to strike the transducers. A carrier board that looks very promising for this sensor is the e-CAM50\_CUNANO offered by E-Con Systems.

### 3.2.9 Camera Comparisons

In order to create a cohesive video observation and telepresence system, a vision system must be devised that supports intuitive control and interaction with the environment in which the submersible is deployed. While stereo vision would be a great boon to this immersion, mono is more compatible with the other systems discussed in this section. A mono video feed also will generally halve the amount of video information that needs to be pushed up the cable to the base station.

In order to maximize visibility, a motion platform for the camera, or a gimbal, has been considered. It has been shown by prior works that a motorized gimbal linked with the accelerometers in a head mounted display can create a very immersive video experience in first person view drone racing. This is also a method of creating a stereo video experience that allows for any angle of observation of the world. This system requires having blackout regions, or significant mechanical design work in order to support slip rings, bearings, and other means of allowing continuous views of the world, while not tangling the system up in its own cabling. A single fixed camera, on the other hand, is the simplest video solution mechanically. A small bracket is all that is needed to point a camera off through a porthole. If the viewer is observing the feed on a fixed screen no further processing is needed for the system.

*Table 6: Comparisons of considered camera sensors*

Device	Price	Resolution	MIPI-CSI Lanes
Omnivision 5647	\$19.99	2952 x 1944	2
IMX219	\$29.69	3280 x 2464	1
AR0251	\$89.00	2592 x 1944	2

Adding complexity to the fixed mono camera is to mount multiple cameras pointing out from the submersible orthogonally. Mounting cameras with sufficiently wide angle lenses allows for complete observation of the environment, but creates a very high amount of video data, and much of this data may never be seen by the operator.

### 3.2.10 Camera Selection

We have elected to use the IMX219 sensor, mounted on the Raspberry Pi V2.1 Camera Breakout board. The compromise was made between the high quality capabilities of the e\_CAM50\_CUNANO and the lower price points of other camera modules. In comparison to the Omnivision 5647, the IMX219 reaps a great benefit from being a single lane MIPI-CSI device.

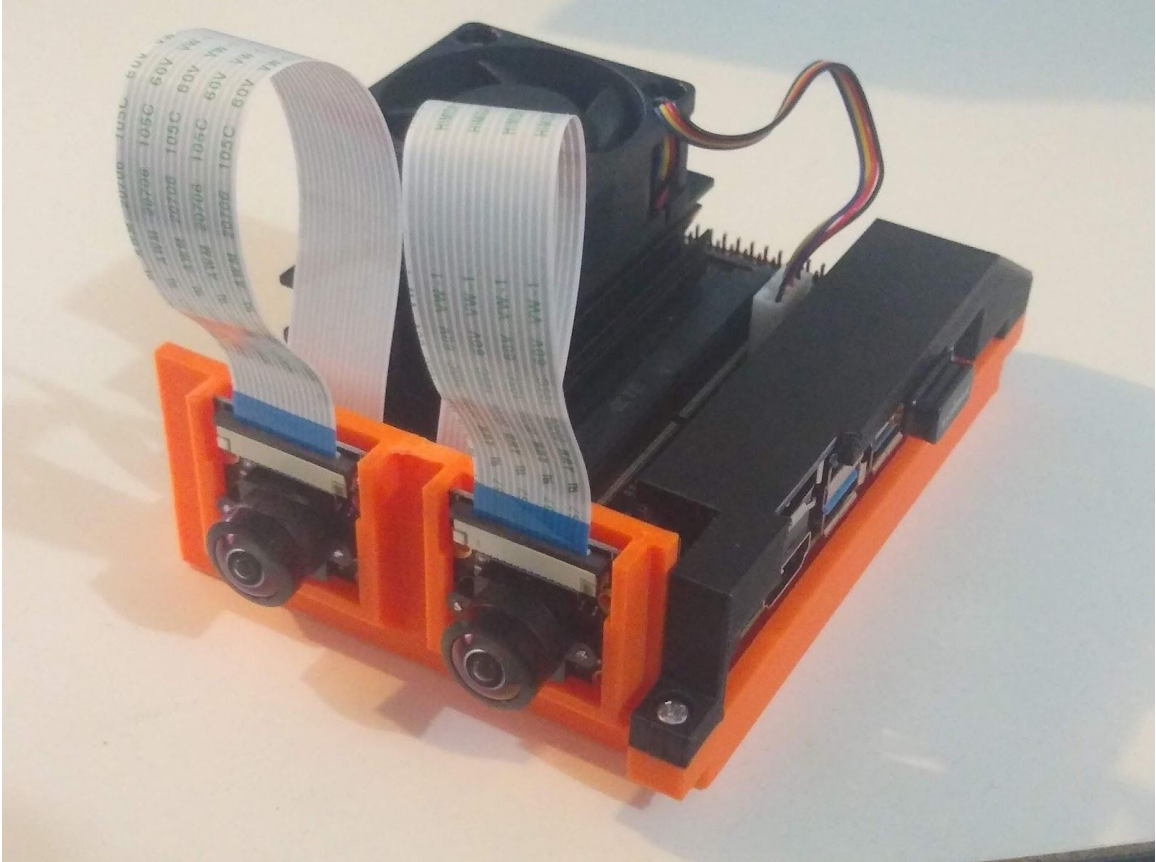

*Figure 17: The Waveshare IMX219-200, featuring IMX219 and a 200° FoV lens*

Having selected the NVIDIA Jetson Nano for this project, a computer that supports a dozen MIPI-CSI lines, the carrier board from NVIDIA only supports two lanes of MIPI-CSI. Carrier boards that support more full-featured, and higher resolution cameras are outside of the price range for this project. This decision was made based on the goal of using multiple cameras to create an omnidirectional video system. Had we elected to focus on a single video feed, the compromises made could have supported an alternative sensor module.

## **3.3 Positional Feedback**

The positional feedback from the ROV is crucial to the control of the ROV. An inertial measurement system will help the ROV in knowing how much power to send to which motors so that it stays stable while in the water. Inertial measurement units can consist of three different ways to measure motion. An accelerometer on the IMU chip will report changes in linear motion in all degrees of freedom. A gyroscope will give the current yaw, pitch, and roll. Lastly, a magnetometer will give you the direction that the ROV is currently facing.

### **3.3.1 BNO055 from Bosch Sensotec**

This chip is a nine degree of freedom inertial measurement unit. The chip combines a gyroscope, accelerometer, and magnetometer on a single die with a high speed ARM Cortex-M0 based processor which takes in all of the sensor data and reports useful data in quaternions, euler angles, or vectors. The BNO055 connects to the single board computer using I<sup>2</sup>C, and has prebuilt linux libraries and documentation. The BNO055 costs \$34.95. [16]

### **3.3.2 BerryIMU from Ozzmaker**

The BerryIMU v2 is a nine degree of freedom inertial measurement unit that uses a LSM9DS1 IMU sensor. The sensor combines an accelerometer, gyroscope, and magnetometer. This chip only gives the raw sensor data. Additional processing is required to get the sensor data into a usable data format. The BerryIMU v2 also comes with a BMP280 barometric sensor, which could be used by the onboard computer to calculate the current depth of the ROV. The BerryIMU costs \$15. [17]

### **3.3.3 9DoF Razor IMU Mo from SparkFun**

The SparkFun 9DoF Razor IMU Mo uses a SAMD21 microprocessor to output euler angles given from a MPU-9250 9DoF sensor. The microprocessor is a 32-bit ARM Cortex-M0+ microcontroller, and it can also be programmed to monitor and log motion. The documentation on this IMU is somewhat lacking and finding drivers for it to connect to a linux based machine has been challenging. The breakout board for this sensor costs \$35.95 at SparkFun. [18]

### **3.3.4 Positional Feedback Conclusion**

We're choosing the BNO055 from Bosch Sensotec. The chip does the complicated math and gives the single board computer simple to work with Euler angles. This chip has the most readily available documentation, and has Linux support. The breakout board for this sensor is given below in *figure 18*.

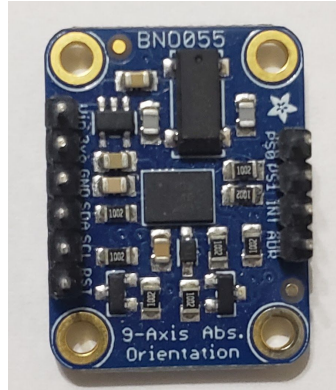

*Figure 18: BNO055 IMU*

## **3.4 Metal Detection**

One of the main features included in Bottom Feeder is a metal detector. We want our project to be able to scan for and retrieve metal objects in the water. While doing some research, we found that there are three main types of metal detectors that are commonly used: beat frequency oscillation, very low-frequency, and pulse induction. In order to decide which detection type to use we should first look at how each type works and what current applications apply to each.

### **3.4.1 Beat Frequency Oscillation**

Beat frequency oscillation is the simplest type of metal detector that is made. This type of detector uses two coils that are very close together. One of these coils (usually the larger diameter coil) sends out a low frequency current. When this current comes in contact with a metal item it creates what is called an “eddy current”. The eddy current is then detected by the second, smaller coil and then some type of signal is output to the user to inform them.

Many detectors use a speaker to output a constant humming sound that will sound noisy or decrepitate when the eddy current is detected. One major flaw with this type of detector is that it is very susceptible to ground mineralisation. This means that it will not be a good choice for our project since we want to be able to detect objects in sand underwater.

*Figure 19* shows how beat frequency oscillating metal detectors send out an electromagnetic field that is echoed back by the metal underneath. This echo is what the detector is looking for to indicate what type of metal is found. Depending on the time it takes for this “echo” to be received by the detector is what is used to determine the type of metal that is in the field. If the signal or the “echo” is lingering around longer than when no metal is present, this means that the object is a ferrous metal. If the signal dies down faster than normal, then the object is a nonferrous metal. If there is no change, then no metal is in the field. This is how all the metal detectors work, and the different types of detectors do different things with the information they pick up from the field.

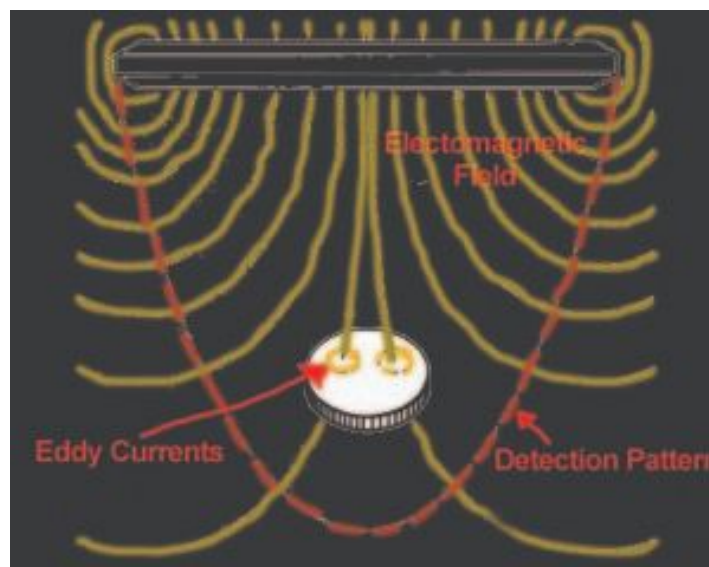

*Figure 19: Beat Frequency Oscillation*  
Reprinted with permission pending, from [19]

### **3.4.2 Very Low-Frequency Detectors**

Similar to the beat frequency oscillation detectors, the very low-frequency detectors use two different coils. One of the coils acts as the transmitter and the other acts as a receiver. The transmitter sends out a constant electric current that the receiver will pick up and amplify. Together, these two coils make a magnetic field that can go a foot or two underground. When this field is passed over certain metals, they will react with a magnetic current that disturbs the transmitted magnetic field. Each metal that interferes with the magnetic field will have a different effect. These different effects can be output through a speaker and used to distinguish between different metals. This can be very useful for someone who

is looking for a lost gold ring and doesn't want to waste time digging around when another type of metal is detected.

### **3.4.3 Pulse Induction**

Pulse induction works by sending an electromagnetic pulse out and measuring the response. If there is no metal to interfere with the pulse, then the measurement taken will be a signal that decreases at a uniform rate. If there is metal in the range of the electromagnetic pulse, it will create a smaller secondary pulse in the reverse direction and the signal measurement taken will not drop uniformly. If the detector can pick up on the secondary signal caused by the initial signal reacting in the metal, then it can detect the presence of metal. A common analogy for describing this functionality is echolocation. If you yell in a room with sound-absorbing walls, you will not hear yourself. But if you place a large enough object that will return sound, you can hear your signal come back as an echo.

### **3.4.4 Best Detector For Our Project**

The best type of detector for our project is going to be the Pulse Induction metal detector. This type of metal detector will not be able to distinguish between different types of metals, but it will be able to output a yes or no signal to our system that will explain if there is metal or not. By keeping the output to a simple “metal or not” we reduce the complexity of operation and can maintain an intuitive design. Several existing pulse induction metal detectors use a simple LED on the end of the device that will turn on when metal is being detected. This type of output will be more suited to our project as it keeps things simple for the user. This simple 1 or 0 for metal detection is also perfect for sending an output to the user’s HUD that we plan on having so that they can detect metal without sound. If, for some reason, the HUD is unable to perform this, we could always leave the LED on the metal detector and just aim the camera at it.

We looked into some of the metal detectors that we could purchase that satisfy our requirements for a metal detector. Most of the detectors that meet the specifications we need cost around \$100. There are a few copycat detectors out there, but below is a simple table, table 7, with the cost and depth ratings of the most affordable options. These metal detectors themselves would need to be stripped down somewhat to get rid of the features that are built in. For example, the MD - 750 is supposed to vibrate and turn on an indicator LED when metal is



successfully detected. If we are to choose this option we need to disable the vibration feature and we also need to connect the detector to the main ROV power supply to eliminate having to take it apart to change the battery.

*Table 7: Metal Detector Comparisons*

Device	Price	Maximum Depth	Voltage	Detection Range
Wedigout MD - 750	\$109.99	100 Feet	9V	3.9 Inches
KKmoon Metal Detector	\$112.99	100 Feet	9V	N/S
<i>Kingdetector MD-4030</i>	\$0.00	TBD	9V	7 Inches

Although it may not be a top-of-line product, the Kingdetector MD-4030 was generously donated to us. Ultimately, it will likely be more advantageous to us to modify our free device. To begin the modification process, we'd need to make the coils water-proof. Once we have a waterproof search coil, all we need to do is build the rest of the circuit in a waterproof housing and we will have a working metal detector at a very low cost. Our metal detector is pictured below in *figure 20*.



*Figure 20: Kingdetector Metal Detector MD-4030 Search Coil*

However, choosing this metal detector does come with its disadvantages. One of them may be that it'll take more effort to rework its components to fit our water-proofing needs. In spite of this drawback, as long as we can achieve the engineering requirements we have defined, the low-cost benefit will surely outweigh the cons.

## 3.5 Power

Power is the most important aspect of our project for many reasons. The most obvious reason is that our project cannot operate without it. We need power to operate each and every feature we will have. In order to make sure everything is going to operate correctly, we need to understand how much power every feature is going to draw. Then we can figure out how we want to supply the power that we need to accomplish our goals. *Figure 21* is a simple diagram that shows the overall power flow of the project.

The project will be broken up into two major parts: the surface station and the ROV. We need to have power supplied to the surface station and its features, and separate batteries that will be used to power the ROV and its features. We will most likely be using power from the wall to power the Pi (or laptop) on the surface station, but we also want to be able to use a battery when needed (for cases when wall power is not an option). We can also use PoE to supply power to the Jetson nano from the surface to reduce the load on the batteries in the ROV.

The ROV power is going to be two different batteries that will power different features. The bilge pumps that we are using to generate thrust will require the most power, so we will need to get a larger battery for those to make sure we can meet our runtime requirements. The second battery can be a little cheaper since it will power features that will not be used as frequently as the bilge pumps (the lights, the metal detector, and sensors).

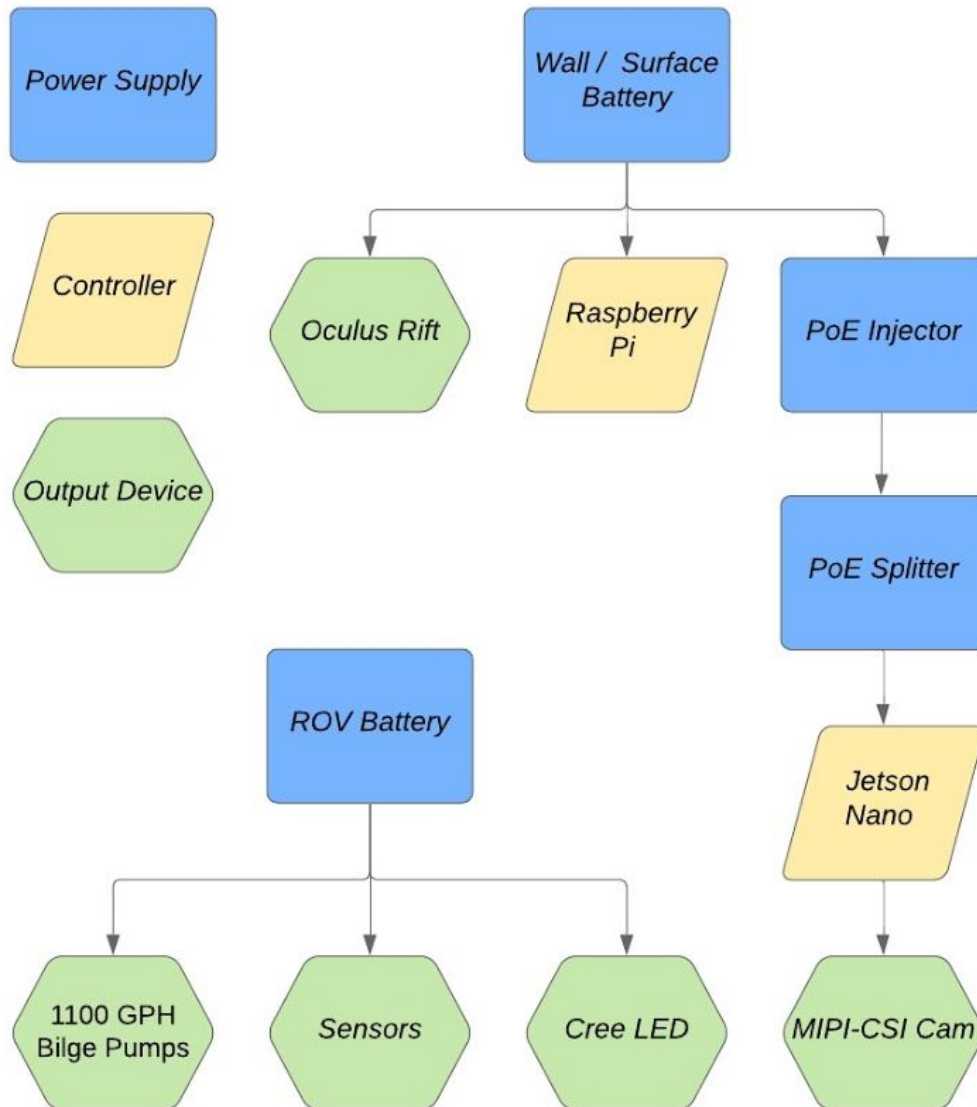

Figure 21: High-Level Power Flow

This flowchart only shows the high-level flow of power for the project. This chart does not represent the physical connections between each component. The controllers will have many more connections between themselves and the output devices. Devices that do not need power from the two main batteries are not shown here (mainly the controller). Based on this design, there are two power supply systems for our project, the surface system battery and the ROV battery.

### 3.5.1 Powering The Surface System

The surface system will have a raspberry pi that controls the inputs and outputs of the ROV as well as the oculus rift for video output. Since the movement

controller will be directly connected to the Pi or have its own power source, the only power problem to solve is that of powering the Pi and the oculus rift. The Pi requires an input of 5V and 2A to function properly, and the oculus rift requires 5V and 1.5 Amps. To accomplish this, we want to be able to use a battery or a pack of several batteries to keep things simple. We should also be able to hook up our surface system to the wall if we are able to in the environment we are working with.

### **3.5.2 Surface System Battery**

In order to power the surface system, we want to be able to use a battery pack whenever we cannot plug it into a wall somewhere. A simple battery pack that connects a few AAs is all we need in order to power the Raspberry Pi. If we use a rechargeable set, we can save money on powering the system over the course of many expeditions. We can also make use of non-rechargeable batteries if there are concerns about the capacity of rechargeable batteries decreasing over time.

To increase the capacity of the battery pack we can use more batteries in parallel by adding more to the pack and using a DC-DC converter to regulate the output. We also have the option to have multiple battery packs and simply swap them out as needed during operation. The other option we have is to buy a larger battery that has a much higher capacity. This option is still cheap, but it will not be as simple to change out the battery due to it being more expensive. Some of the larger batteries can take long hours to charge as well. What we are looking for is a battery that has a large enough capacity to keep the system running for over an hour. We have plenty of physical space for the surface station so we can get as large of a battery as we need to. We are also looking for something that has at least 5 Volts minimum since the Pi and the Oculus Rift require about 5 Volts to operate. Table 8 offers some details that we can use to compare battery options for our surface system.

Table 8: Surface System Battery Options

Device	Price	Voltage	Capacity
ExpertPower EXP12100	\$26.99	12 Volts	10 Amp-hr
ExpertPower EXP645	\$12.99	6 Volts	4.5 Amp-hr
MightyMax ML18-12	\$35.99	12 Volts	18 Amp-hr
Zeee 2S LiPo 7.4V	\$35.69 (for 2-pack)	7.4 Volts	5.2 Amp-hr

The MightyMax battery is going to be the best option for the surface system due to the fact that it is extremely affordable for the offered capacity. We do not need 12V, but most of the lead-acid batteries that are on the market right now are used for scooters and similar projects. The battery we purchased is seen in *figure 22* below.



Figure 22: MightyMax ML18-12

We can take this battery and regulate the voltage for the raspberry pi and the oculus rift to ensure they have the proper inputs. With this much capacity we

should be able to operate the surface system for a very long time without stopping to recharge. For now, we have a cheap charger we can use, but we may also need to create our own circuit for charging this battery. We could also purchase a charger for it separately down the road depending on the remaining time/budget.

### 3.5.3 Power over Ethernet

Aside from onboard batteries, another way to supply power to the ROV is through a tether. Our tether will be a long Ethernet wire. If the surface system could send power down to the ROV in any capacity, it would help reduce the battery capacity we need to have underwater. One method of achieving this is through the use of “Power over Ethernet”. Power over Ethernet is exactly what it sounds like. It is the ability to supply power and information over the same cable. This is commonly used today in IP cameras and VoIP phones. PoE can be sent from a network switch to any PoE compatible device.

Due to existing IEEE standards on PoE, it should be a relatively easy way to power up some of the features in our ROV. The Jetson we are using inside the ROV supports PoE if additional power conditioning is added to its GPIO header, and we will be able to power it from the surface system if we choose to. This could help reduce the power consumption coming from the battery so it can be used for driving the motors and lights. Based on some research, we found that PoE should be able to supply enough power to our Jetson Nano, which requires at least 10 Watts. The more features we use with the nano the more power we will need. *Figure 23* is a small chart that shows how much power is able to be supplied by a network switch.



*Figure 23:* Network switch and standards for PoE output  
Reprinted with permission, from [20]

In order to use Power over Ethernet, we will have to purchase or use an existing network switch that has the capability. The one shown in the picture above runs for about \$140. This can output up to 120W, but we would have to use all eight ports on the device and having 8 long cables will add an even higher cost to our project overall. Power over Ethernet still seems like a viable option to power the Jetson only. If the Jetson was being powered by the surface system or if the ROV batteries ran out, we would still be able to get video coming from the ROV to the user. This could help us get some stationary video for longer amounts of time than we could achieve without Power over Ethernet. We will most likely need to have a very large capacity battery inside or on the ROV in order to power the motors and lights as well as any additional features. We will also have to decide on spending more money to get a switch just to power the Jetson, or if we want to use that money to buy a larger capacity battery.

Another option we have is to use PoE to potentially charge a battery that is on the ROV. If we can come up with a way to accomplish this safely, we would be able to charge the ROV from the surface system. This could add a small amount of time to the runtime of the system because we could charge it up while it is stationary or when the load is small enough. This would be nice for the spherical housing design as it would allow the ROV to get some battery power whenever the user is just looking around without moving the ROV.

Table 9 displays some of the options we are looking at for PoE injectors. They seem to be relatively cheap, and with any of these options we should be able to power the Jetson on the ROV via POE. This will allow us to continue streaming video to the headset even if the battery on the ROV runs out.

*Table 9: Power over Ethernet Injectors*

Device	Price	Power Output	Distance Supported
TP-LINK TL-PoE150S PoE Injector Adapter	\$30.00	15.4 Watts	328 feet
BV-Tech Gigabit Power over Ethernet PoE+ Injector	\$20.00	19 Watts	250 feet
Cudy POE300 60W Gigabit Ultra PoE+ Injector	\$49.90	60 Watts	N/S

We decided to go with the TL-PoE150S pictured in *figure 24* because it outputs enough power to operate the Jetson Nano. We could have chosen an injector that offers more power, but for the cost and supported distance this one is more than adequate. We may also be receiving this from a friend and if so, it will save us some money on this feature.



*Figure 24:* TP-Link TL-PoE150S  
Reprinted with permission pending, from [21]

Since we want to use PoE to get power to the Jetson, it would be very helpful to get a PoE splitter to go with the injector. The Jetson has a female barrel jack port and if we get a splitter it will “split” the power and data that is received from the injector. To summarize this, the injector can be powered by a battery or the wall and it will send both power and data over the Ethernet cable. The Ethernet cable will go into a splitter that is inside the ROV. The splitter takes the Ethernet and separates the data and power signals again. We can then plug the barrel jack and Ethernet separately into the jetson. Table 10 shows some comparisons between different splitters that are within our price range.



Table 10: PoE splitter comparison

Device	Price	Output Voltage
TP-Link TL-POE10R	\$17.13	5/9/12 V
UCTRONICS Active PoE Splitter	\$8.88	12 V
Amcrest Active PoE Splitter Adapter	\$19.98	5/9/12 V

The splitter that we will use is the TP-Link POE10R. This option is the cheaper one of the options that have a 5V output mode. Since the PoE standard allows for 15.4 Watts to be sent across the cable, if we set the output of the splitter to 5 Volts, we should be able to achieve 3 Amps maximum at the splitter output. This will be a little smaller in actuality, but it is rated to supply 2 Amps, which is what the Jetson needs to function. The Uctronics splitter is the cheapest, but we would have to design a regulator to lower the voltage from 12 Volts down to the 5 Volts we need. There is no need for a picture of the splitter because TP-Link uses the exact same case for the splitter as the injector. The only difference is a couple ports and the label in the corner.

### 3.5.4 Surface Station Power Alternatives

Batteries are not the only usable option to power the surface system of our project. One of the options to power the surface system is the use of wall power. We need our surface system to be powered by a battery, but there are some cases where getting power from a generator or an outlet would be possible. In some cases the user may be operating our ROV on a dock or they may have a generator on their boat that allows them to get power outside the use of our battery systems. Another alternative power option for the surface system is solar power. Since we will be using our ROV in the water, it is likely that there will be plenty of bright sunlight shining down on us. For a user that already has access to solar power, they could simply hook up the surface system to their solar power supply. This would make our project powerable even in the most remote locations of the earth.

The Pi can be powered with the universal power supply (USB connection) as well as wiring up the pins manually. The AR headset is going to get its power from either the surface system or the battery of the cell phone inside. If we decide to

use Power over Ethernet, we could plug in the switch that we use to supply PoE into an outlet. It would be great to be able to charge our surface system battery while it is on the jobsite. We could also add the capability for the device to switch between battery power and wall power if it is able to be plugged in. This way we could charge the batteries up and operate the ROV and surface system at the same time. Since power is so important we should make sure we design our ROV for the case where there is no external power source, but make it able to take advantage of the situation when it is available.

### **3.5.5 Powering The ROV**

The ROV will have many things that need power: controller, lights, motors, cameras, metal detector, etc. In order to power all of these things we will need a battery capacity large enough to allow the ROV to stay underwater as long as possible. We also don't want to spend too much money on a battery. Existing submersible ROVs have battery lifetimes that range from 1 hour to above 3 hours. Since we want our project to be comparable to existing products, we need to try to reach a minimum of 1 hour run time. The major deciding factors on how we will need to pick our power option are: physical size of the ROV and the number of features we want to have. The more things we want the ROV to be able to do, the more power it is going to draw. Once we get to a certain number of features and power draw, we will have to start increasing the size of the battery to support them.

### **3.5.6 ROV Battery Power**

There are a couple of options that we can choose from to get power to the ROV and all of its components/features. The first way that comes to mind is to use a battery with a large capacity. Lead-acid batteries are very widely used because they are extremely cheap. Lead-acid batteries have two lead plates inside of them. The first plate is the positive plate and it is coated in a lead dioxide paste. The second plate is the negative plate and it is made of a sponge lead material. Between the two plates is an insulating material called a separator.

This type of battery can give us a large capacity for a low financial cost, but they are much larger than some of the other battery options out there. If we go with an ROV design that could allow for a physically large battery, then lead-acid would be the way to go. We can get our hands on a 12 Volt, 10Ah capacity battery for

under \$30. We just need to make sure that the battery we choose does not need good ventilation as some lead-acid batteries do.

For the spherical housing design option, we will need to use a battery that takes up the least physical space possible. There are many different lithium batteries that are available for purchase. These LiPo (lithium polymer) and LiHV (high voltage lithium polymer) are used for many different types of RC vehicles like cars, drones, and boats. These batteries would work for most housing designs we can pick from, but they are typically more expensive for the capacity they supply. A LiPo battery that is 11.1 Volts with 5000 MAh capacity goes for about \$50.

This is where we have to decide what we need more in our batteries: smaller physical size, larger capacity, or somewhere in between. If our ROV is going to be larger, we should go with the larger battery because it will more easily support a large power draw. If we can manage to keep the ROV small, we will be able to power it with a smaller battery. We will also have to take into consideration the amount of power the ROV will be consuming. The more features we have, the more power we will need to draw. So not only do features affect the physical design of the ROV, but also the number of options we have for batteries in our budget. These things must be balanced out as we have discussed through the house of quality section of this document.

Most of the LiPo battery packs come in 11.1 Volt or 14.8 Volt packs. Since the bilge pumps we decided to use for thrusters need 12 Volts, it is best for us to use the 14.8 Volt batteries, or to go with a NiMH battery pack. We also need a capacity large enough to allow the ROV to operate under normal usage for a minimum of one hour. We estimate that to reach this minimum time, we will need at least 4200 mAh capacity to operate the bilge pumps alone. Since one of our members already owns a Turnigy 11.1V 3200 mAh battery, we can use that to power the other features and we only would have to buy a battery to drive the bilge pumps. Table 11 below compares a few of the options worth considering.

Table 11: ROV Battery Options

Device	Voltage	Capacity	Price
Gens Ace (LiPo)	14.8 Volts	10 Amp-hr	\$89.99
Turnigy (LiPo)	14.8 Volts	10 Amp-hr	\$89.23
Turnigy (LiPo)	14.8 Volts	5 Amp-hr	\$32.81
10EP4200SC (NiMH)	12 Volts	4.2 Amp-hr	\$54.95
Tenergy (NiMH)	12 Volts	4.2 Amp-hr	\$69.99

We decided to use two separate LiPo batteries for the ROV in order to save as much money as possible. The main issue with the NiMH batteries is that we don't have a charger for them. We would have to purchase a charger separately or find someone who is willing to let us borrow/keep it. Getting one of the larger capacity LiPo batteries would be great for keeping the physical size of the battery to a minimum, but they are more expensive. We also don't need to have that much capacity to power our ROV for the minimum runtime goal that we set. The best option here is to use the battery we already have for the other features of the ROV, and purchase a new battery for the bilge pumps. These batteries are pictured in *figure 25* below:



Figure 25: Turnigy 11.1V 3200 mAh (top) and 14.8V 5000 mAh

Based on our research, we found that lead-acid batteries are a great option for power because of how cheap they are, but they tend to be too large and some require good ventilation to operate safely. NiMH batteries meet the power requirements and have a relatively affordable price tag, but they require a charger that we do not currently have access to. For all of these reasons combined, we decided to use two different batteries since we already have one battery that should suffice for the operation of the components other than the bilge pumps. This will allow us to take advantage of batteries we already have, and we can split the power consumption across two different batteries with different voltages.

## **3.6 Tether**

ROV's can either be wireless, or more commonly, tethered. Although tetherless, or wireless forms of ROV's exist, they're not recommended due to the poor range of radio frequency underwater. This results in a more costly bot that simply doesn't have all the gadgets found on its tethered counterparts. For this reason, our bot is going to be tethered.

The tether, sometimes called the umbilical, is the cable linking the body of the submersed ROV to the tether management system on the surface. It's used to supply power and communicate with the electrical components on the underwater vehicle. Most ROV's include a tether for both the power and signaling needs of the vehicle in conjunction with, for power specifically, onboard ROV batteries. Oftentimes there is a tether management system (TMS) on the surface to help store and protect the long tether cord. In our case, our TMS would likely translate to a nice reel or 'winch' in order to wrap the cord and avoid tangles. A hand lever would be used to wrap our tether around the device. A typical industry-grade tether from Fathom is displayed below in *figure 26*.



*Figure 26: Fathom ROV Tether*  
Reprinted with permission, from [22]

The cable design itself starts with the use of a conductor for electricity to travel through. Typically, this means copper, specifically tin-plated copper. There is also silver-plated copper that's ideal for higher temperatures but this is quite pricey, and won't be considered for our project. The copper wire has a measure of gauge or American Wire Gauge (AWG), the USA standard. Lower numbers correspond to thicker conductor diameters. Wires that are too thin may pose problems when supplying power to our ROV. Common AWG sizes for ROVs may range from 14 to 26 gauge. A Cat6 cable usually has a 23-AWG which equals 0.0226 inches in diameter. Next, it's important to talk about the wire's stranding. Wires are usually stranded or solid. Solid wires contain just a single, thick strand of copper wire. [23] While standard wires are quite durable, it would not be favored for our purposes. It is recommended that our wire is stranded, or containing multiple wires bundled tightly together, sometimes forming twisted pairs. Not only do we need to separate the wire strands when we're soldering it to multiple electrical components inside the ROV, but stranded wires are much more flexible and are less likely to become damaged while being bent.

Now, let's talk about the conductor's insulation, which will be used as the housing for the electrical energy. The two kinds of insulation commonly used in ROV's is thermoplastic and thermoset. Thermoplastic material becomes softer when heated and hardened when cooled, while thermoset material changes its molecular form when heated. The latter requires special equipment to work with and thus, won't be an insulation consideration for our project. Some examples of common thermoplastic material is listed below:

- Polyethylene (PE)
- Polypropylene (PP)
- Polyvinyl chloride (PVC)
- Polyurethane (PUR)
- Nylon
- Fluorocarbons [24]

A hollow polypropylene rope seems to be the popular pick (likely due to its inexpensive price-point) and will be highly considered. A half an inch hollow cord sells for as cheap as \$20 on websites such as Amazon and Ebay. Since most network cables are already insulated with polyethylene or PVC, the polypropylene rope would also serve as a means to protect the already-jacketed tether from strain when being dragged underneath the water. It may also provide more buoyancy to the tether, which is an important feature discussed further in the tether criteria section below.

The cable is then wrapped together using a sheath or jacket. It's recommended to use a low-density jacket to help offset the negative weight of the copper wire. Common ones include polyolefin and polyurethane. The strength member of the cable is also important and in industry a steel wire strength member is the standard with galvanizing coating covering the outside for corrosion protection. Steel strength members are usually associated with a wire that is as strong, waterproof, kink-free, corrosion-free, etc. Mechanical considerations to make include:

- (Anticipated) working load
- Maximum peak dynamic load
- Minimum bend radius/diameter
- Expected cycle-life performance [24]

Thus far our anticipated working load is an onboard processor, thrusters, lights, sensors, and a power system. It's important that our wire is able to supply for all of these work loads. At the moment a Cat6 or Cat5e ethernet cable seems mechanically suitable for the job. *Figure 27* represents the sort of wire one might consider in industry. Although an ideal, industry-approved steel wire strength member would be great, such a luxury would probably come at too steep of a price for our project.



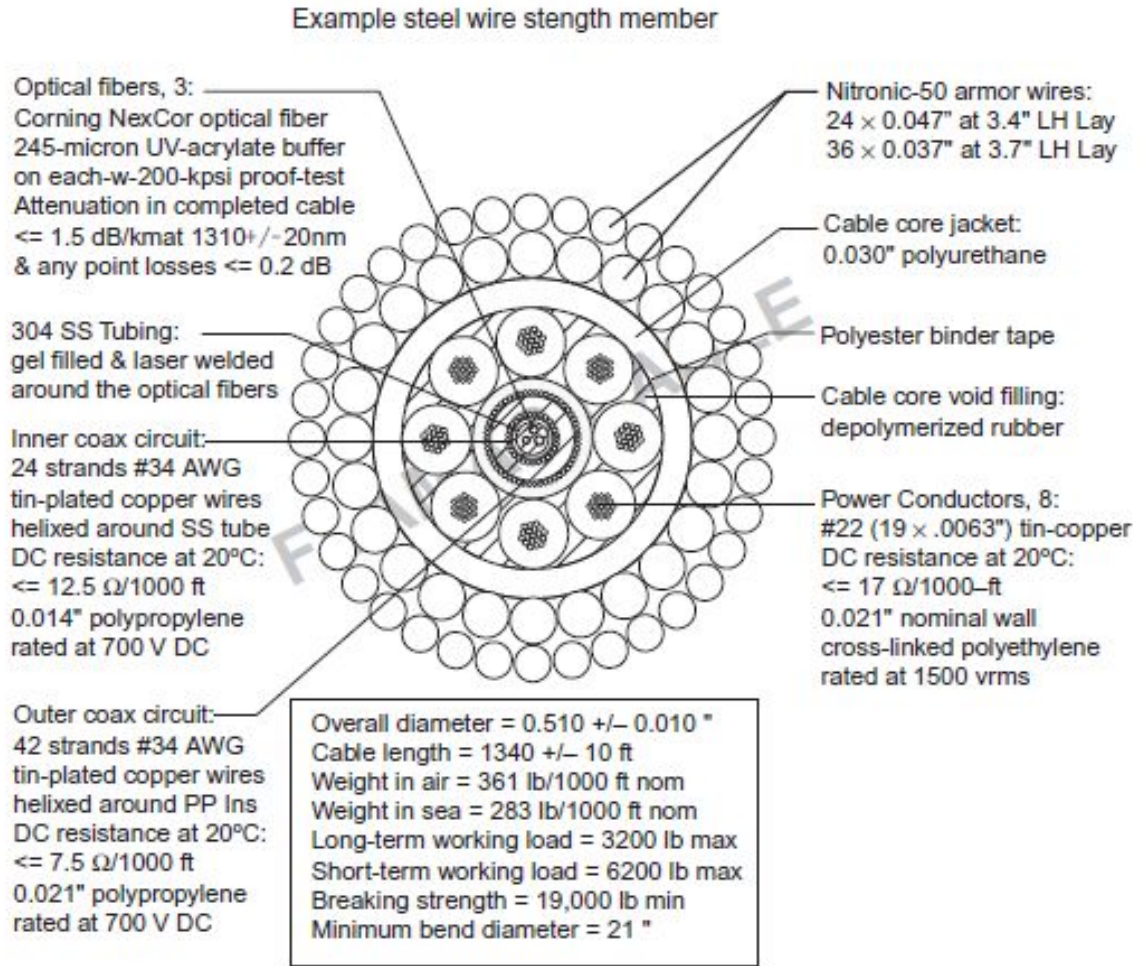

*Figure 27: Steel wire strength member*  
Reprinted with permission pending, from [24]

### 3.6.1 Tether Criteria

There are a couple of criteria we must take into consideration before we decide how to make our tether. The first one of them being how much power needs to be supplied through the cords to the ROV. Our underwater bot needs to power up the thrusters, microcontrollers, sensors, lights, and the camera with enough voltage to make it run efficiently. The resistance will only increase with our tether's length, resulting in a voltage drop. We can compensate for this by increasing the conducting wires gauge to allow for more flow, but this may also result in a more expensive or heavier tether.

A heavier tether brings up another vital component known as buoyancy, or how the cord floats through the water. There are three kinds of buoyancy to consider.



The first is positive buoyancy, which happens when the tether floats because it is lighter than the surrounding water. The second is negative buoyancy and causes the tether to sink in water due to too much weight. Usually, these first two applications are not desired in an ROV. The third, and most ideal, is neutral buoyancy. This causes the tether to stay suspended in water by getting very close to the same weight as water. A neutrally buoyant tether is far superior because it stops the cord from dragging on the body of the water's floor (or floating to the top). In turn, that reduces the ROV's drag which conserves the power consumption needed by the thrusters to haul the cord around. Taking that into consideration, if we discover that our tether is too heavy, we may find the need to add floatation devices to achieve neutral buoyancy. [25]

Signals will also be transmitted through our tether. Signal transmission can be analog or digital as well as electrical or optical. Specifically, the feed from our camera needs to be transmitted through our cord to a device, such as a raspberry pi or laptop, on the surface. We also want to be able to monitor data like depth, temperature, battery level, ionizing radiation, metal detection, etc. As stated earlier, we will likely be using optical fiber in the form of a Cat 6 Ethernet cable. Parameters to consider are attenuation, bandwidth, and wavelength. It's common practice to have a separate group of cables for signal transmission but other than that, the wire used for the signaling requirements is very similar to that of the power requirements. [24] Whether we will be considering this is to be determined.

### **3.6.2 Our Tether**

For our design we have two options for the tether; make it ourselves or buy an already assembled one from a reputable manufacturer. If we were to create our own, again, we'd be using a waterproof Cat 6 Ethernet cable for signaling and power. A Cat 5e Ethernet cable will also be considered due to it being budget-friendly. However, a Cat 5 cable may not meet our demands. The core of these cables are 'flooded' or filled with gel in order to make them waterproof. The benefit of using an Ethernet cable would be lowering the cost. However, some things to contemplate is the weight of an Ethernet cable. They're quite heavy and an addition of floatation devices on the cord may be necessary. Another thing to note is perhaps having a separate wire to power on the camera to avoid any inconsistencies with the feed from other components on the ROV draining power. Or, on the other hand, we may be able to use the onboard batteries for most of our power needs and most of the signaling being run through our Ethernet wire.

The other option would be to buy our tether already made. This may increase our cost but perhaps save us time and be the more reliable option in the long run. Common tether's available on the market are those from BlueRobotics [22]. Their Fathom ROV Tether has the price point of \$175 dollars at 25 meters. This is definitely overkill for our 10m goal but premade ROV tethers typically do not offer shorter lengths. However, since their products are specifically made for their ROV's, adjustments may need to be made to the wiring to suit our purpose. Table 12 below gives us a clearer view of the pros and cons of buying our tether versus making it.

*Table 12: Buying Our Tether Vs. Making It*

	Pros	Cons
Buying	<ul style="list-style-type: none"> <li>● Reliability</li> <li>● Time-efficient</li> </ul>	<ul style="list-style-type: none"> <li>● Pricier</li> <li>● May have to adjust to fit our power needs</li> </ul>
Making	<ul style="list-style-type: none"> <li>● Cost-efficient</li> <li>● More hands-on experience</li> </ul>	<ul style="list-style-type: none"> <li>● Time consuming</li> <li>● More trouble-shooting</li> </ul>

After weighing the pros and cons, we are leaning towards making our own tether. We are currently in possession of 800 feet of Cat 6 Ethernet wiring. For now, this will suit our needs for brief submersion testing. *Figure 28* below displays a picture of this stranded wiring that we have on-hand.

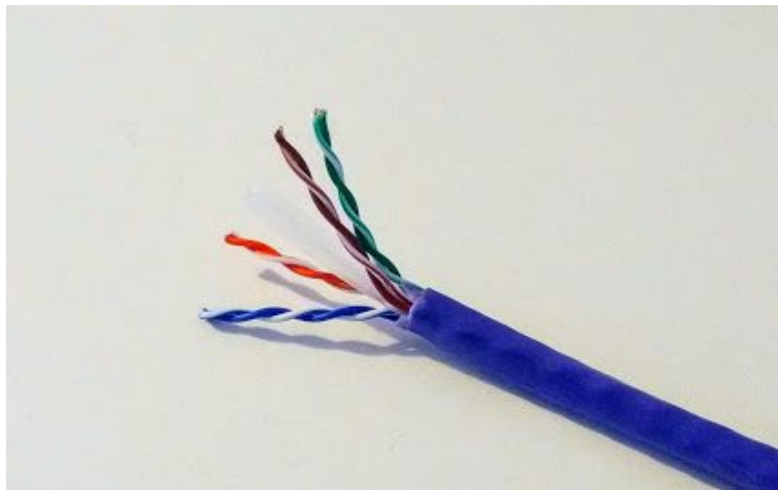

*Figure 28: Stranded Cat 6 Ethernet cable*

We will later be buying a Cat 5e or Cat 6 gel-filled Ethernet wire to fulfill our needs for long-term testing.

## 3.7 Depth sensing

Depth sensing in a submersible vehicle is typically accomplished through sensing the pressure of water outside the vehicle and converting that to a below-sea-level depth using a linear formula. Pressure sensors generally operate based on a moveable surface or membrane that restricts the push of water pressure. There is a small amount of movement possible on this surface, depending on the force, and it is through this mechanical deformation that pressure is detected. Some sensors use a piezoelectric disc to create a static voltage based on the pressure applied to the disk. Another technology falls into the MEMS category, and uses a sealed cavity with two conductive surfaces separated by a spacer. A pressure applied to one surface will compress the cavity, moving the conductors closer together and increasing the capacitance of the chamber. This change in capacitance is then observed and translated into a pressure reading. They may also use a piezoresistive material for the deformable surface, and measure the change in resistance as a result of the surface's strain.[26]

We can take the density of surface freshwater to be 1000kg per cubic meter, and seawater to have a density of 1027kg per cubic meter [water density thing]. Knowing that hydrostatic pressure is calculated based on the column of water directly above a surface, it can be shown that the effective pressure on any submerged surface is as follows in equation 1.

$$P_{static} = \rho \cdot d \cdot g$$

Equation 1: Equation for hydrostatic pressure,  $P$ , given density,  $\rho$ , depth,  $d$ , and the acceleration due to gravity,  $g$ .

Rearranging this equation to solve for depth, we have the following result equation 2.

$$d = \left( \frac{\rho \cdot g}{P_{static}} \right)$$

Equation 2: This expression calculates depth as a function of pressure

By using a sensor that is able to give us a static pressure on the surface of the ROV, we can calculate the depth we are operating at. This depth will be dependent on the density of the water we are deploying in, and this dependency can be mitigated with an operator-accessible setting.

### **3.7.1 LPS33HW Pressure sensor**

This sensor, offered by STMicroelectronics, is made up of a pressure sensitive transducer, a ducted port to allow access from the environment to this transducer, and an integrated circuit that is able to be read via either SPI and I2C. A physical port is integrated in the housing of the device, providing a safe and convenient method of exposing the sensing region to the exterior environment, while preventing ingress of water. The I2C communication aspect of this component is a large benefit. The more components in this project that can be configured to communicate over a shared bus, the less hardware space is consumed by managing disparate communication schemes. This component is available on an evaluation board from Adafruit that exposes the communication bus and power connections to a single connector. The sensor reports pressure data with 24 bit accuracy.

The LPS33HW, despite its benefits in simplifying electronics design, using it to determine depth of dive is limited to a smaller range than the following options. Accurate readings are limited to 126 kPa, which limits accurate readings to 12.8m of depth or less. This approaches half of our planned depth rating, and is not ideal for our use case. Used in conjunction with another sensor, this may allow for more granular sensing of depth at shallower operating conditions. The sensor is rated to tolerate, but not accurately report at, up to 2500 kPa, or 250m of depth.

This sensor will also report ambient temperature, which could be added to a list of product features when marketing the final device.

### **3.7.2 Autex Pressure Transducer**

With a 3ms response time to pressure changes and an analog signal as its method of information delivery, a fuel pressure sensor produced by Autex has seen an increase in usage by hobbyists looking to monitor pressure in any number of DIY projects. A controller with an ADC integrated, or added as an external IC is necessary in order to interpret its results. Per the manufacturer datasheet, a signal of 0.5V indicates that the transducer is exposed to atmospheric pressure, and a signal of 4.5V indicates that the operating surface is exposed to a pressure of 1034kPa. This pressure, found at a depth of roughly 104m, far exceeds the other operating goals of the device.

### 3.7.3 Pressure Sensor Comparisons

The LPS33HW provides an easy to integrate solution for digital electronics and computing systems. The all-in-one nature of the sensor removes much of the work needed in order to get started with it, where it provides sensing, conversion, storage, and bus-accessed control and readings. The fuel pressure sensor would provide readings over the entire range of operation of the ROV, but unfortunately is designed for analog feedback systems, and would require additional circuitry and support systems to be able to provide information to a microcontroller or a single board computer.

*Table 13: Comparisons between various pressure sensors*

Device	Max. Depth	Resolution	Price
LPS33HW	12.8m	10 Amp-hr	\$12.78
AUTEX Transceiver	104m	Continuous/ADC dependent	\$28.99

### 3.7.4 Pressure Sensor Selection

We have elected to use the fuel pressure sensor for our device and craft a driver board incorporating a bus-access ADC to provide a comparable interface to the LPS33HW sensor, while being able to observe and report on depth at all supported operating depths.

## 3.8 Geiger Counter

A Geiger counter is an apparatus used to detect ionizing radiation. The most common of these emissions being beta particles, alpha particles, and gamma rays. It works by filling a tube with inert gas across which high voltage is held. When exposed to radioactive emissions, the particles crash into the gas causing it to conduct electrical charge. When enough charge is created, it is registered on a meter to determine the surrounding radiation. [27]

Industry-wise, the practice of using Geiger counters on ROVs is most commonly for inspecting cooling tanks within nuclear power plants. [24] However, our use would be to see if there's any radioactive pollution in rivers or lakes. Such a device added to our ROV would be helpful in monitoring the health of the body of water's ecosystem. We currently are in possession of a Mightyohm Geiger Counter V1.0 pictured below in *figure 29* [28].



*Figure 29: Mightyohm Geiger Counter V1.0*

It's sensitive to beta and gamma radiation. The device would need to protrude outside the ROV's enclosure in a thin, waterproof tube to ensure accurate radiation readings from the water. It'd take a bit of work to properly wire and install the hardware, but afterwards our homebase on the surface should be able to pick up clicks when radiation is near the Geiger-Muller tube. As of this moment we have uranium-doped radioactive glass and a uranium sample for testing purposes.

Our consideration of even using this Geiger counter was thanks to a generous donation. Not only is the kit already built but we have access to the source code and hardware schematics. However, in the grand scheme of things this Geiger counter falls under lower priority. Programming our signals to be sent to the surface properly may prove daunting. Whether or not it's going to be implemented in the final product is to be determined.

### **3.9 Lights**

Having Lights on the ROV is going to be essential. We need to be able to light up many areas as the ROV maneuvers around and looks for great pictures or valuable metals. Since we want our ROV to be able to move around at ~10m depths and possibly travel through coves or explore shipwrecks, we need to have acceptable lights in order to see. The measurement for light is called the Lumen. A lumen is, by definition, the SI unit of luminous flux, equal to the amount of light emitted per second in a unit solid angle of one steradian from a uniform source of one candela. Every light you look at buying has a lumen value

associated with it so that you know how bright the light actually is. So how many lumens do we want our underwater lights to have? Based on some of our research and some posts from night divers, 1000 lumens should be more than enough to see in our maximum depth range.

There are many factors that go into deciding what lights to have on our ROV. If we want to light up a wider area for taking better pictures, then we will need to have a wider angle which will reduce the visibility range. If we want better range and brightness we can go with the smaller angle design. Depending on what housing and camera setup we use, we will likely use different lights. With a static, stereo camera system we would want to have smaller angle lights that are mounted to the outside of the ROV. This is the most common setup that you see on affordable ROVs. They typically use one high quality fixed camera with two small flashlights mounted on either side. If we want to have ~360 degree video and use a spherical housing, then we will want to have a wide angle light on each side of the ROV in order to light up more area for video capturing.

### **3.9.1 Purchasable Options**

One of our options is to buy a flashlight component that is designed for projects like ours. This is the most expensive option because underwater flashlight components like this tend to be overpriced (around \$50 to \$100 per light). The benefit, however, is that it would save us some time when it comes to completing our prototype. We could also use these types of lights mounted in different ways to suit different housing styles. The other pre-existing options are regular diving flashlights. We could purchase a cheap pair of diving flashlights for around \$30 and modify them to run off of the ROV battery and have them controlled by the surface system. This option would be very cheap, but it would not provide much room for mechanical design. Essentially we would be using the case that they come in since it is waterproof and we would simply mount them to the outside of the housing. This may not be the best option for the ~360 degree camera setup either because cheaper diving flashlights don't have very wide angles.

### **3.9.2 Making Our Own**

If we make our own lights, we have total freedom to make any angle and any brightness we need for our project. There would also be the potential to design the lights so that they mount to the inside of the housing. If this is possible, then

we would not need to spend extra money on a waterproof case for the lights and they could be made to function on either housing design we pick.

In order to make the lights we need, we would purchase the emitter, reflector, and lens if necessary. The emitters go for a few dollars and the reflectors and lenses are even cheaper. This would save us a lot of money, but it would take up the most time. If we are unable to fit the lights inside the housing, we would have to make a waterproof case for our lights so they could mount to the outside of the housing. This would become much more expensive and time consuming as well. But if we can make room inside the housing for these lights it will allow for much more freedom in the type of lights we want for our project.

Another idea we had for our lights if we get the omnidirectional video working is to build a strip of LEDs or make several LEDs that mount around the housing. This would be great because the user could not only look around using the headset, but the lights could also be programmed to turn on or off depending on where the user is looking. For example if the user is looking to the south then only the south LEDs would be on. As the user turns their head, the LEDs ahead of their vision would begin to turn on and the ones that are leaving the field of view would turn off. This concept would definitely be something we make ourselves. Even if we could buy an LED strip that would satisfy the programming criteria, we would have to put in much brighter LEDs to be able to flood the darkness and get more range of vision in the dark.

### **3.9.3 Comparison and Selection**

For our project the best option we have for lights is going to be making our own. We can purchase high power LEDs that are manufactured by Cree and implement them into our ROV in any way we see fit. One of our ideas was to come up with a loop of LEDs that circle the ROV and activate as the user looks around using the Oculus Rift. This idea is great, but with the time constraints we have, we feel it would be better to go with something simpler for now. Lights are one feature that we want to have, but our time can be better spent elsewhere on the project. To get the most out of the lights, we should go with one or two high powered LEDs that will be mounted to the ROV on the front, or on either side to light up the surroundings. Of the LEDs that are out there, Cree makes several different LEDs that have the angle and brightness that we are aiming for of over 1000 Lumens. They also offer components that can be ordered as 1 up or triple-up, meaning that they have 1 or 3 LEDs on the same piece. This allows for some different Lumen measurements from the same device. If we chose to use a



smaller angle, we would not need lights this bright, but for simplicity's sake we are looking at the options in the table below:

*Table 14: Cree Lights Comparison*

Device	Price	Brightness	Voltage	Angle
Cree XLamp XHP35	\$7.75	1712 lm	11.3 Volts	125°
Cree XLamp XP-G2 (Triple-up)	\$10.99	1758 lm	3.9 Volts	115°
Cree XLamp XP-665-1	\$6.99	1150 lm	2.95 Volts	125°

We decided to go with the XP-L due to it meeting the minimum requirements we are looking for of 1000 lumens. The angle is a bit wider than we need, but if necessary, we can always add a reflector to direct the light in whatever focus we need. The power drawn by the XP-L is also the lowest out of the other options considered due to the fact that it has the lowest brightness.



*Figure 30: Cree XLamp XP-L-665-1*  
Reprinted with permission pending, from [29]

This LED is pretty expensive for an LED, but due to the fact that it gives off over 1000 lm on its own means that it is going to be exactly what we need. Without enough brightness, it will be very hard to see as our project goes deeper underwater. With the XP-L we should have an angle of light that is wide enough to somewhat illuminate the viewing angle that we expect to have with our

cameras on each side. As we test this LED we can determine if the angle needs to be decreased in order to increase the range of the light for better vision range. We will have to buy or make a reflector to modify the output of the LED to suit our project's needs. Due to this component being relatively small, we plan on putting it in a transparent dome around it to protect it from water.

## **3.10 Operator View**

Viewing a remote video feed can be done with a fixed screen or a head mounted display. In the case of omnidirectional video, either display option can track to a certain position with manual control, or support motion tracking. A head mounted display with motion tracking will create the most immersive experience for the system operator. A fixed display with no motion controls, on the other hand, is the most technologically straightforward system to develop.

Existing remote environment control solutions can be seen in mobile video games. A full screen visual stream is overlaid with virtual control options and heads up display elements. These controls can include camera pan and tilt controls, or they may allow the user to observe different angles of view by tilting the tablet device.

Head mounted displays are available from a variety of manufacturers and fit a variety of budgets. Google's Cardboard and Daydream hardware solutions offer a way to use existing smartphones for a head mounted system. The set up relies on a user having a smartphone that functions as mobile transceiver, accelerometer and compass, and screen. What is added to these smartphones is a head mounted unit that holds the phone a certain distance from the eyes, a pair of lenses to help the eyes focus on the screen at such a close distance, and a shrouded chamber to prevent excess light from spoiling the experience. Many of these headsets also have straps to free up the operators hands to perform other tasks.

There are also higher quality HMD solutions that are purpose built, and do not require any additional electronics provided by the user. These solutions are more expensive on their own, but also can provide a more finely tuned experience, as all units produced are known to have a single display size, and capability, and can be engineered from a more holistic perspective.

In order to aptly control the device, the operator must have feedback on the position, orientation, sensor data, as well as information regarding the state of the machine, such as battery level and temperature of the device. Heads up

displays are frequently used by pilots in order to non-intrusively have access to telemetry data.

## **3.11 Control System**

The home base system needs a way to receive inputs from the user to then send control information to the ROV via the tether. The ROV will need inputs telling it to move horizontally, vertically, and to rotate to the left and right. The most practical way to receive the user inputs is using a typical video game controller. Our home base system has a bluetooth receiver, so using an already owned Playstation 4 controller makes the most sense economically. The Playstation 4 controller has two analog sticks each giving two degrees of freedom. It also has two analog triggers, twelve digital buttons, a gyroscope, and force feedback. The force feedback feature could be used in conjunction with the metal detector and alert the pilot whenever a metallic object has been found [30].

## **3.12 Housing**

While water is intrinsically an insulator, dissolved ions greatly decrease the resistance of the medium. In fresh water, this resistance can be as low at 50 to 100 Ohms meters, and in seawater this can go as low as 0.2 Ohms meter. In order to maintain functional electrical systems, they must be protected from contact with the surrounding environment.

Existing submersible equipment shows that there are myriad solutions to this problem. These range from sealants applied directly to electronics, creating an artificial safe environment for the electronics using a resealable enclosure, and finally moving all electronics above water and only submerging systems that can more easily cope with the presence of fluids.

### **3.12.1 Permanent Enclosures**

A straightforward method of protecting submerged electronics is to apply a sealant directly to the vulnerable components. The options for these coatings are diverse. Room Temperature Vulcanizing silicone can be sprayed on to electronics after testing is complete and creates a durable, impermeable barrier. A benefit of RTV coatings is that they can sometimes be peeled off in cases where electronics require additional testing or reworking of components. Another solution to prevent ingress of water into a board is to "pot" the electronics in their final housing by use of an epoxy. This creates an incredibly durable layer of protection

for electronics, but has a major drawback of being a permanent process. If the circuit were to fail after potting, the effort of extracting it from its resinous tomb is generally not worth the effort. This is primarily used in very hostile environments where more temporary and accessible solutions may fail faster, and only when a system has been thoroughly tested and is expected not to fail before its task is complete.

### **3.12.2 Resealable Enclosures**

Complex submersible systems, and those that may frequently require attention or modification will use resealable enclosures to house their onboard electronics. These generally have gaskets or seals between separable components, allowing mechanical flexibility while preventing fluid ingress when properly secured. These enclosures can be opaque metals, transparent acrylic, or many other options. The transmission of light through an enclosure becomes an important issue when there will be a video system housed within.

### **3.12.3 PVC Scaffolding**

Frequently used as a scaffolding and structure by ROV hobbyists and enthusiasts is PVC plumbing fittings. These are designed for long term contact with water, are rigid enough for structural members, but not so stiff as to be brittle and fracture under most light bumps. They provide easy ways of creating enclosures for submerged systems that will resist the ingress of water, and allow for highly customizable and creative solutions to be produced. They are limited by the selections offered to consumers however, and being designed and produced with the needs of plumbing in mind, and thus may not readily provide all parts or fixtures desired by the ROV creators. Optically clear pieces of PVC are more expensive than those fixtures and pipes available for residential and commercial plumbing.

## **3.13 Electrical Feedthroughs**

Feedthroughs are components that allow electrical connections to pass through a physical barrier. These can be rated to separate high pressure systems or vacuum systems from the atmosphere, or to allow electrical signals to penetrate a submerged vessel without water making ingress. When selecting a feed through, it is important to select one that matches the signal content and current requirements of the wiring that will connect to either side. Feed throughs can

allow for removable cables on either side, or can be permanent connections. Radio frequency signals or analog waveforms may benefit from a coaxially terminated feedthrough, and these systems can even provide electrical connection to the chassis of the system, helping to eliminate electrical noise at the point of penetration.

When selecting a submersible feedthrough for an electrical signal, it must also be considered if the connection should be able to be mated while underwater [31]. If it is rated for wet connections, then the feedthrough must physically push away any errant water in the connection as the various contacts are made between the two halves. Excessive water present at the mating point could create dangerous or error-producing shorts between the conductors. Dry mate connectors form a seal around the connection points and prevent water from entering the joint, but they do not have the same ability to evacuate all fluids, and they require that the two halves of the system be totally dry when mating. There are also underwater mating connectors, rated for plugging and unplugging while submerged, but they cannot be powered while unmated underwater.

### **3.13.1 Wet Mate Connectors**

Subconn/MacArtney manufactures a broad selection of both wet mate and dry mate feedthroughs and connectors. Their eight pin wet mate feedthrough technology allows for up to 400VAC potential between conductors and a maximum per-pin current of 10A, while the complete 8 pin connector should be limited to no more than 50A. They also offer an Ethernet capable connector with 5 additional conductors, and market this as a solution that is able to transmit additional power, without using the power-over-Ethernet standard.

### **3.13.2 Dry Mate Feedthroughs**

Dry mate connectors and add-on cable glands offer a compromise between affordability and flexibility. One option for dry mate feedthroughs are cable gland connectors. These allow for rematable connections

### **3.13.3 Permanent Feedthroughs**

For permanent, non mating, transmission from outside the enclosure to inside, a compression gland can be used. This is made of a threaded insert that can be passed through a penetration in the housing, and holds a gasket against the cable moving through as well as itself, and uses compression to apply a great pressure

to these seals. Mechanical force is what prevents ingress of water, although vibrations and flexing of the cables can lead to slow ingresses of water. These are not suitable for long term and unsupervised penetrations, as water may need to be emptied from the enclosure periodically.

### **3.13.4 Feedthrough selection**

We have elected to use a dry mate RJ45 feedthrough for our tether, and a permanent compression gland feedthrough system for all onboard connections. The dry mate RJ-45 connector system allows for off the shelf Ethernet connectors and CAT6 cabling to carry data and some power, without moving to a multi-hundred dollar solution for feedthroughs.



*Figure 31:* The dry mate RJ45 cable gland that will be used to connect the tether.

## **3.14 Object Retrieval**

One of our ROVs main functions will be the ability to detect and retrieve metal items while traversing through watery depths. The first idea that has been explored is a grabbing appendage that could pick up items in a mechanical claw-like manner. Buying such an item is likely out of the question due to the price point that is explained in the previous sections above. However, we could make such an apparatus. Important things to bear in mind when creating an item-retrieval claw would be grip force, jaw opening, pressure rating, and of course, making sure the entire device is water-proof. Our target items to be retrieved are pictured below in *figure 32*.



*Figure 32: test items for ROV sensor testing and retrieval*

Included are 98% gold coins, 90% silver coins, a gold necklace, and gold earrings. Note that the glass bowl and rock are for potential radiation testing, not for retrieval. These items are relatively small so our grip force for our proposed arm wouldn't be demanding, nor would its jaw opening have to be very large. However, it's important that the arm could withstand water pressure up to 10 meters deep, as per our requirements. The material could simply be made out of plastic to keep cost low. Internal parts may include a linear actuator and motor. It's important that the electronic components are properly sealed and housed in a waterproof tube.

Our second consideration would simply be a device that scoops up the target item from the water's sandy floor. Its design would look very much like your standard diver's scooper, which includes small holes for gravel and sand to pass through with a back enclosure that secures your target object. The scooper would need to be made of material, such as plastic, that doesn't interfere with the metal detection. We would probably adhere the device to the bottom of our ROV. By using our camera and manually controlling the movement of our ROV through a controller, we will drag our scooper through the sand and pick up our desired metal. The retrieved item will then be brought to the surface. The pros and cons of both designs are compared below in *figure 33*.

	Pros	Cons
Mechanical arm	<ul style="list-style-type: none"> <li>• Greater range of motion</li> <li>• Accuracy</li> </ul>	<ul style="list-style-type: none"> <li>• Pricier</li> <li>• Time consuming</li> </ul>
Scooper	<ul style="list-style-type: none"> <li>• Cost-efficient</li> <li>• Simple</li> <li>• No moving parts</li> </ul>	<ul style="list-style-type: none"> <li>• Poor range of motion</li> <li>• Less accuracy</li> </ul>

Figure 33: Mechanical arm vs. scooper for object retrieval

Ultimately, we are likely to favor the scooper over the claw arm. Although the claw would give us more range in picking up our objects, the cost of assembly and time would likely be too great. The scooper is simple, inexpensive, and requires no moving parts.

### 3.15 Home Base

Our homebase will consist of a raspberry pi, a head mounted display, PoE switch, and a controller. Options for a power source include a wall outlet, generator, or a battery that can power at least 5V and 1A. A generator would likely be too costly and is probably going to be excluded as an option in our final product. A wall outlet could be a powerful source of voltage but the downside is the availability. We can't always rely on there being an outlet available for plugin, especially near a body of water. This leaves us with a battery, our most likely candidate for powering our home base. We plan to make this our bare minimum for powering, with an addition of a wall outlet plug-in. Connected to this raspberry pi will be our head mounted display and a controller. Additionally, there may be a laptop on the surface for further computing power when it comes to controlling and collecting the data signals that are sent and received. Another consideration is the use of a waterproof, padded case to store our surface components. If we were to utilize such a thing, we would likely use a pelican case. The head mounted display will show real time video of the camera footage from the ROV below the water, and the controller will be used to move the ROV. We would like the head mounted display to display a relevant portion of the camera feed from onboard the ROV to give us a stunning, full view of the underwater terrain. Lastly, the surface's homebase will include a PoE switch or Power over Ethernet. This will allow for our Ethernet cable to transmit not only signals but power to our underwater remote operated vehicle. A clearer view of what we have in mind for our home base can be seen in the block diagram below in *figure 34*.



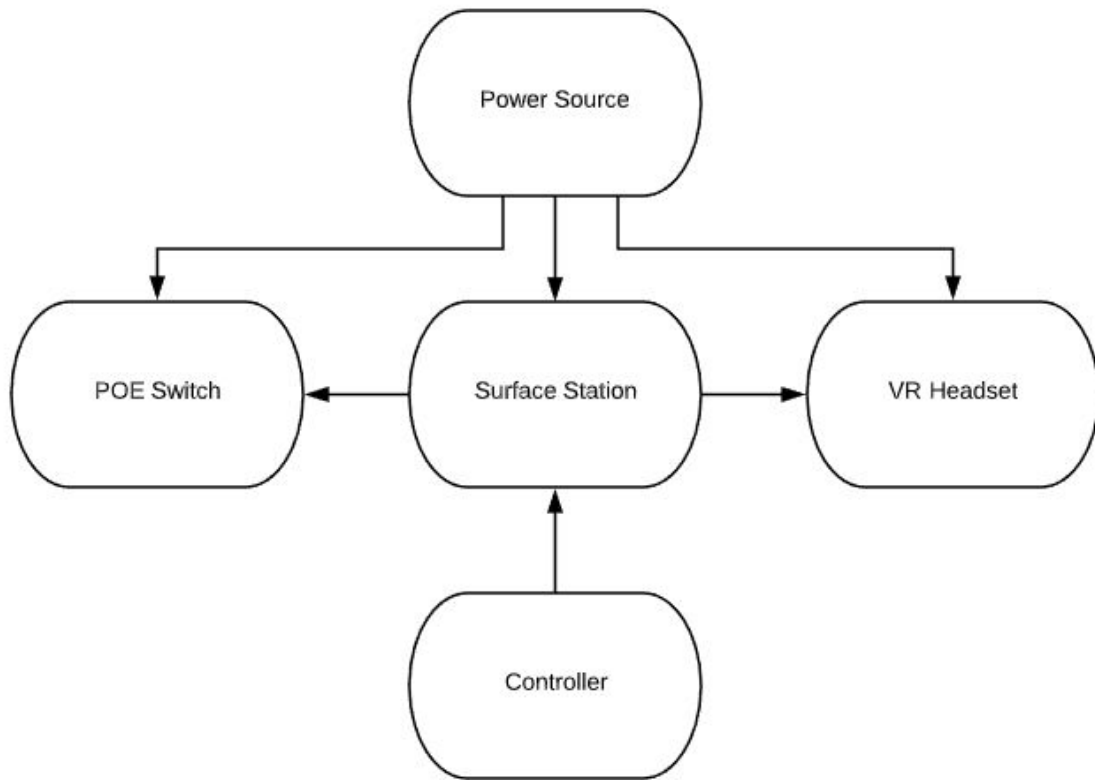

*Figure 34: Home base block diagram*

### **3.16 Sonar**

Sonar, or sound navigation and ranging, involves the use of sound waves through water to identify targets. This is done by reflected sound frequency and intensity, much like whales or dolphins communicating underwater.

Sonar is a very common feature for many ROVs that need to navigate through murky waters and some practical applications include:

- Echo sounding for bathymetry
- Side-scan sonar for bathymetry and item location
- Underwater vehicle-mounted imaging sonar for target identification
- Geophysical research
- Underwater communications
- Underwater telemetry
- Military listening devices (passive sonar) for submarines and shipping identification
- Position fixing with acoustic positioning systems

- Fish finding
  - Acoustic seabed classification
  - Underwater vehicle tracking over bottom
- Measuring waves and current [24]

There are two fundamental types of sonar, active and passive. In active sonar, a signal is sent out and part of this signal will be reflected back. By taking measurements of the time between when a signal is first sent out and when that signal is reflected back to the receiver, one can determine the distance to a targeted object. In active sonar, these received signals can then be used for imaging of the target. On the other hand, passive sonar only receives signals and does not transmit. An example of passive sonar would be receiving a signal from an underwater creature and then being able to determine their location. [32] If we were to include sonar, we'd likely want active sonar.

The backscatter, or the reflected sound from the object that is being insonified, displays the desired results depending on our ROVs specific needs. Examples of some backscatter analysis:

- Multiple bounce depth sounder backscatter is analyzed with acoustic seabed classification systems to determine the texture and makeup of the sea bottom (sand, mud, rock, oyster bed, kelp, etc.) for environmental monitoring as well as vessel navigation.
- Doppler shift backscatter is used for vehicle speed over ground as well as current/wave profiling.
- Frequency shift backscatter is analyzed in CHIRP sonar systems to discriminate between objects in close proximity.
- Simple high-frequency backscatter can characterize a target as to aspect, texture, surface features, and orientation. [24]

Our use for sonar was mostly based around finding objects underwater when the surroundings were dark and muddy; conditions in which our light couldn't remedy the visuals. We also entertained the idea of a fish finder. However, we looked at all our options when it came to including sonar in our final design but unfortunately, as useful as sonar would be to our ROV, it's not likely to be included in the final product to keep cost down. Cost usually begins at around a \$300 price point and for now, that is simply outside of our budget. It will be lowest on our priority list.

## **3.17 Main Onboard Computer**

The main onboard computer for the ROV system is responsible for controlling and interacting with all of the different systems on the ROV, and sending information to the homebase system. The onboard computer must take in camera input, process that video information into something usable, and send that processed video feed to the above water station. The main onboard computer will be responsible for all motor outputs, so it will need a way to send control signals to multiple motor drivers. The main onboard computer will also be responsible for reading all sensor data coming from the ROV, including the depth sensor, readings from the inertial measurement unit, and information from the metal detector. Finally, the main onboard computer needs to be able to have two way communication with the home base station above the water.

### **3.17.1 Raspberry Pi 4**

The Raspberry Pi is a single board embedded computer that is typically used for education and prototyping uses. The most recent Raspberry Pi, the Raspberry Pi 4, costs only \$60 for the 4 GB version and boasts a quad-core 64 bit Arm processor running at 1.5 GHz. Included in the board is a ton of different interfaces. There are two USB 3.0 ports, two USB 2.0 ports, 2 micro HDMI ports, Ethernet, built in 2.4 GHz and 5.0 GHz IEEE 802.11B/g/n/ac Wireless LAN, and Bluetooth 5.0. The board also comes equipped with 28 general purpose input/out pins, and one MIPI camera interface. Raspberry Pis typically run on a specially built version of Linux known as Raspbian, which has extensive community support behind it and a wealth of easily found documentation to makes getting started with development easy. The main drawbacks to this board is that it doesn't have a built in analog to digital converter, so an external one would need to be sourced, also the board only comes equipped with one MIPI camera slot so running a dual camera stereo vision system could prove challenging. [33]

### **3.17.2 Nvidia Jetson Nano**

The Nvidia Jetson Nano is a single board computer that was designed with enough power to run artificial intelligence projects, neural networks, and other large development projects. The Jetson Nano runs on a quad-core ARM Cortex-A57 MPCore processor with a dedicated graphical processing unit running

Nvidia's Maxwell architecture with 128 NVIDIA CUDA cores putting out 0.5 teraflops. The Jetson Nano has 4 GB of 64-bit LPDDR4 RAM running at 1600Mhz, and has 16 GB of eMMC 5.1 Flash memory built in. This board runs on NVIDIA's special build of Ubuntu Linux known as Jetpack SDK. The community support is not as thorough as the support the Raspberry Pi has, but NVIDIA does have good documentation to get you started working with the development platform. The Jetson Nano is capable of encoding two 1080p video signals at 60 frames per second. The main drawbacks to this board compared to the Raspberry Pi is that it doesn't have built in WiFi or bluetooth, and the physical board is larger than the Raspberry Pi. In addition, at \$100 the board is more expensive than the Raspberry Pi. The biggest advantage of the Jetson Nano is that it has two MIPI camera input ports which would make using a two camera setup much more straightforward. The increased graphical processing power of the Jetson Nano would enable us to send higher quality video from the underwater vehicle to the pilot on the surface. [34]

### **3.17.3 Libre Computer ROC-RK3328-CC Renegade**

The Libre Computer Renegade is a Raspberry Pi sized single board computer that is primarily used for media centers. It runs on a quad-core ARM Cortex-A53 CPU running at 1.4GHz. It has a dedicated ARM Mali-450 GPU running at 500 MHz, and comes equipped with up to 4GB of DDR3-2133 SDRAM. The Renegade has two USB 2.0 ports and one USB 3.0 port, a HDMI 2.0 port, and a gigabit Ethernet connector. Like the Jetson Nano it does not come with Wifi or bluetooth on the board. The Renegade is able to encode 4k video at 60 frames per second. The biggest drawback to this board is that it doesn't have any dedicated MIPI camera slots. This means that to add cameras to the project they have to be connected to the board using one of the USB ports. The high end 4 GB model of the Renegade costs \$80 which is a little bit more expensive than the Raspberry Pi. It typically runs on either a specialized Linux distribution of Ubuntu, or it runs on Android 7.1. [35]

### **3.17.4 ASUS Tinker Board**

The Asus Tinker Board is a single board computer that is used primarily for Android development. The Tinker Board features an ARM-based RK3288 quad-core processor running at 1.8Ghz. The integrated GPU is based on the

Mali-T764 and has 4 cores at clocks in a 600MHz. It has 2GB Dual Channel DDR3 RAM. The Tinker Board comes equipped with four USB 2.0 ports, an Ethernet port, 802.11 b/g/n WiFi, and Bluetooth 4.0. Like the Raspberry Pi it comes equipped with one MIPI camera port and 28 general purpose input/output pins. While this board is typically used with Android OS it can also run a special build of Debian Linux. The Tinker Board costs about the same as the Raspberry Pi, but seems to be underpowered compared to the newest version of Raspberry Pi. It also has the same drawback that the Raspberry Pi has, with it only having one MIPI camera interface. Documentation and community support for the Tinker Board is scarce, with only basic install information found on the ASUS website and only a few public projects found for it in popular repositories. [36]

### **3.17.5 UDOO BOLT**

The UDOO BOLT is a portable computer that boasts impressive processing power. It has an AMD Ryzen quad-core eight thread CPU running at 3.6 GHz. The GPU is an AMD Radeon Vega 8 which clocks in at 1.2 GHz. It comes equipped with two DDR4 dual-channel slots which support up to 32 GB at 2400 MT/s. It has a 32 GB high speed drive on board with the option to add an SSD via SATA or M.2 socket. It has a gigabit Ethernet, two USB 3.0 Type-A slots, two USB 3.0 Type-C slots, HDMI slots, Displayport slots, and arduino compatible input and output ports. For all that it does come with it does have some glaring omissions. You need to supply your own RAM boards and your own WiFi and bluetooth modules. It also does not have any MIPI camera slots, so all cameras must be connected using USB. It has a few other downsides as well. While it is definitely powerful enough for the ROV applications, the power draw means that running it off of a battery isn't feasible for any substantial length of time. The board size is massive compared to any other board that has been researched, meaning the enclosure would need to be massive to match, which would also affect the size of the motors. The cost is prohibitively large as well. At \$430 the cost of just this board would account for almost half of our entire budget. [37]

### **3.17.6 Onboard Computer Conclusion**

After considering the plethora of boards available we decided to go with the NVIDIA Jetson Nano for our Onboard Computer. The extra power that it packs

compared to the Raspberry Pi means that it can do complicated stereo vision calculations and can also handle 360 degree vision as well. The two MIPI camera slots means we can use IMX219 image sensor based cameras and plug them into the board directly, rather than having to use USB. For power considerations the Jetson Nano is able to run in 5 watt mode or 10 watt mode, meaning we can use less power and extend our battery life.

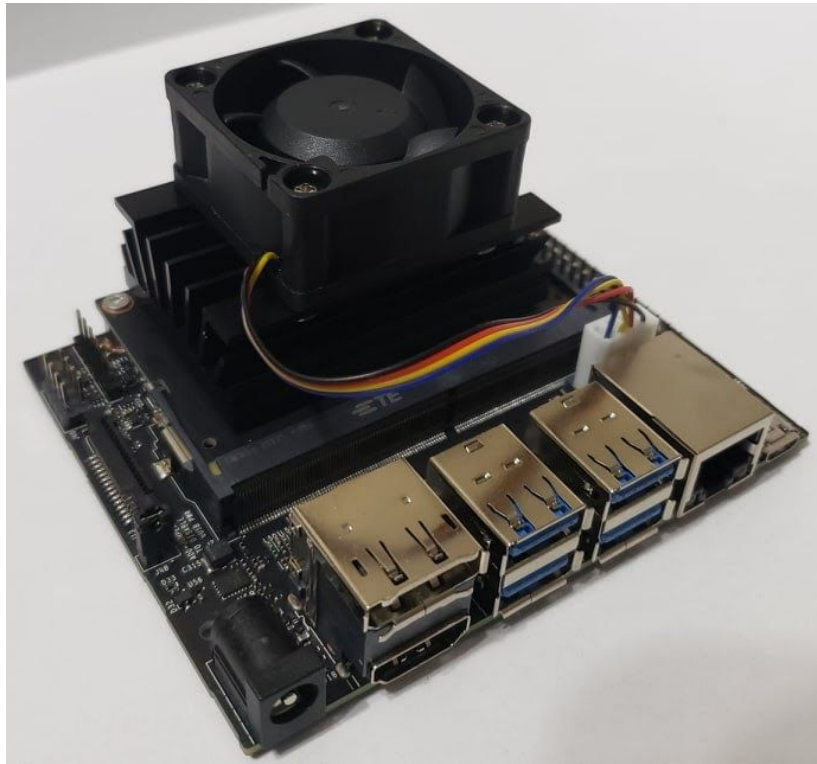

*Figure 35: Nvidia Jetson Nano*

### **3.18 Microcontroller**

The single board computer is able to do a lot of complex calculations, but they are not typically designed to be used for sensor inputs or for controlling motors. The sensor inputs need an analog to digital comparator circuit, and the motors need pulse width modulation pins in order to control the speed and direction of the motor. The easiest and most typical way to add this functionality to a project is to add a separate microcontroller chip to your system. This chip can communicate with the single board computer using any manner of serial communication system, including UART, SPI, and I<sup>2</sup>C.

### **3.18.1 MSP430G2553**

The MSP430 family of microcontrollers are ultra low power FRAM platforms that provide high performance at low energy costs. The G2553 version comes equipped with a 16-bit RISC CPU, two 16-bit timers, and 16-bit registers. For motor driving and sensor inputs the G2553 has twenty four input/output pins, an on chip analog-to-digital comparator, and a ten bit analog-to-digital converter. This chip also has UART communication, SPI, and I<sup>2</sup>C, so it can communicate with the single board computer. [38]

### **3.18.2 ATmega328P**

The Atmega328P is the chip typically associated with the Arduino Uno microcontroller platform. The chip itself has twenty general purpose input/output pins, three timers with compare modes, and internal and external interrupts. This chip has a ten bit analog to digital converter, serial programmable USART, SPI functionality, and communication using I<sup>2</sup>C. [39]

### **3.18.3 SAMD51**

This is an Arduino environment compatible microcontroller from Atmel. A key feature is that USB communication is built into the IC for the purposes of reprogramming as well as UART based communication. With options for clocks as fast as 120MHz, as well as hosting a FPU make this a powerful option for computing pressures and motor control data. [40]

### **3.18.4 Microcontroller Conclusion**

We will be going with the MSP430G2553 for our motor controlling and sensor output needs. The MSP430 has ultra low power usage, only pulling 230  $\mu$ Amps at 3.3 Volts when running in active mode. The internal clocks allow us to drive enough pulse width modulation pins to control all of our motors. The MSP430 has a ten bit digital-to-analog converter which is multiplexed to eight of the twenty external pins in the package. These eight pins are sufficient to sample all of our planned sensors. As an added bonus, the MSP430 was used in the embedded systems class at UCF, and the development board from this class is shown below in *figure 36*. Because this was used in a previous class, not only do

we all have the physical board for prototyping uses, we also have some experience using them.

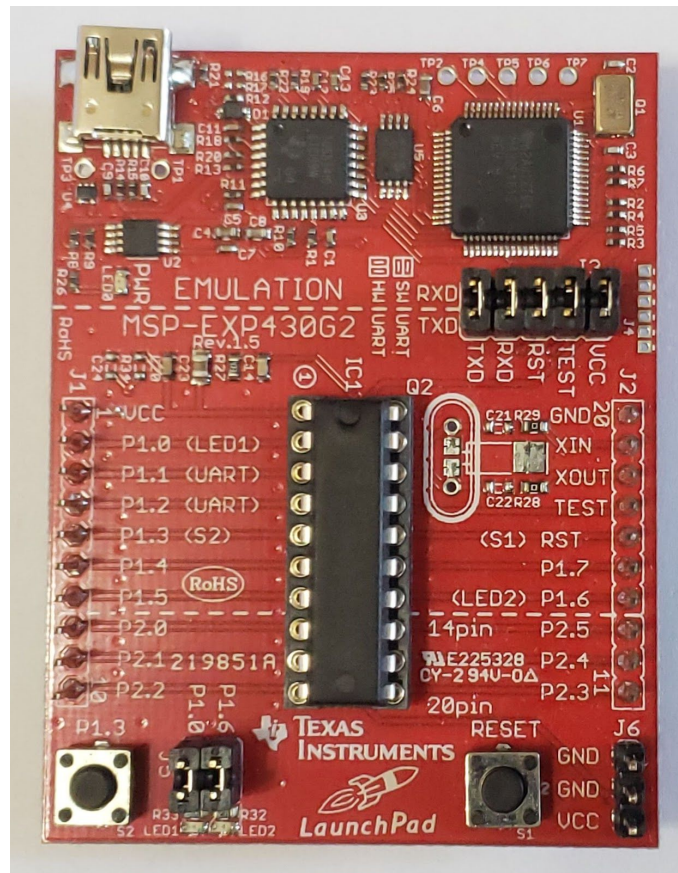

Figure 36: TI LaunchPad using MSP430G2553

## 3.19 Motor Driver

The DC motors being used for the thruster need a way to be controlled so that the rotational direction of the propeller can be changed, along with the ability to change the speed of the propeller. This is done using a specially designed motor driver chip.

### 3.19.1 MDD3A

The MDD3A is a 3 amp h bridge motor driver circuit that is able to drive two brushed DC motors at a voltage range of 4 volts to 16 volts. This motor driver accepts a PWM control signal of 1.8 volts, 3.3 volts, 5 volts, and 12 volts, so it is compatible with many different microcontroller circuits. This driver is equipped



with reverse voltage protection in case the battery is plugged in with the wrong polarity.

### **3.19.2 L298N**

This chip is a full-bridge motor driver with an operating supply voltage capping out at 46V. The total DC current for this driver is 4A, and it comes equipped with overheat protection. The supported logic supply voltage is 4.5 volts to 7 volts

### **3.19.3 Motor Driver Conclusion**

The MDD3A has suits all of our motor driver needs. The 3 amp two channel design means that two chips are able to power all of our motors. The L298N has two channels, but each one is only capable of handling 2 amps at once. This limitation means that one L298N chip is needed to run each individual motor. Unfortunately, due to recent global events, the expected lead time on buying new MDD3A chips is twelve weeks. Which means that there is not enough time to get these chips in and tested before the end of senior design II. With this restriction in mind, we'll be using the readily available L298N motor driver.

## **4.0 Standards and Constraints**

The standards and constraints section details all limitations that impacted the design, testing, and build of our ROV. This includes any published engineering standards that we followed and used in our project, as well as any outside constraints placed on us that we were not necessarily able to control, such as legal, economic, and environmental constraints.

### **4.1 Realistic Project Constraints**

There are several realistic project constraints that we must bear in mind when assembling our ROV. A brief overview of realistic constraints include:

- All electrical components need to be in an airtight enclosure to avoid contact with water
- Outside components need to be corrosion-resistant
- Size of the body or function of the vacuum/metal detector/appendage that picks items up needs to account for narrower areas

- Thrusters must be strong enough to move our ROV around smoothly and combat potential drag
- The power supplied to our ROV must be enough for our payloads
- Metal detector must be able to work in both fresh and saltwater
- Metal detector must not interfere with ROV's electrical or metal components

Most importantly, a tangible, cost-efficient product must be made in two semesters.

### **4.1.1 Impacts from the COVID-19 Global Pandemic**

On Monday, March 16th, the University of Central Florida closed down campus and moved to remote instruction for the remainder of the Spring 2020 semester [41]. Orange County then issued a shelter in place which went into effect on Thursday, March 26th [42]. Finally, the governor of Florida issued a state-wide shelter in place order on April 1st which is scheduled to last for thirty days [43]. Clearly this unprecedented series of events has changed the lives of everyone, and it has had a huge impact on the design, build, and testing of our ROV.

The first hurdle that needed to be cleared was how do we work on a group project separately from all of our respective homes. We were able to acquire all of our already purchased equipment from the senior design lab before the campus was locked down. We were also able to acquire a second Jetson Nano from a friend so that two of us were able to work on the ROV control program together from home. Any other parts of the ROV are being developed and tested separately while this shelter in place order is active. When the order is eventually lifted we'll be able to meet together to combine all of our parts together into a single functional prototype.

The next problem we faced was finding parts while this global pandemic is happening. Most cheap electronic equipment typically comes from China. Because the pandemic started in China most of the industry there shut down making ordering cheap electronics and printed circuit boards a challenge. The only way to get past this hurdle is to make sure that all of our parts are ordered as early as possible, and to use domestic suppliers when available. Doing so will likely increase the cost of our components. Unfortunately some common domestic suppliers are affected by this pandemic as well. Amazon has announced

that they are prioritizing essential items first, meaning that some of our electronic equipment went from having one day shipping estimates to one month estimates. This means that we've had to look to other domestic suppliers for components such as our thrusters.

The last problem faced as a result of the pandemic is how do we test some of our components. Without access to UCF's main campus we lose the ability to use the testing equipment in the labs. This means that any tests that we need to run requires self built testing equipment. This costs additional time to develop the tests and additional money to buy any required testing equipment.

### **4.1.2 Economic Constraints**

We are constrained in producing a prototype by our self-funding. While sponsors were approached throughout the project, due to the financial instability resulting from the COVID-19 pandemic, sponsorship discussions and sample requests stalled. Because of this, the scope of the project has shifted to find more creative solutions that utilize widely available, inexpensive components in order to produce a functioning prototype. Despite the economic constraints we face when producing a prototype of this project, we should also be forward thinking towards production of a commercial unit, and make choices that align with a sustainable business model surrounding the production or operation of a submersible machine.

Typical consumer class ROVs sell for between \$1000 and \$3000, while commercial units can be rented, with pilot, for similar fees daily. The commercial units are typically outfitted with expanded sensor and articulation capabilities, and that more closely aligns with our goals in producing this submersible. Selecting for sensing platforms that align with commercial needs provide a path for a strong return on investment in any components and assemblies required to support these sensors. It is with that in mind that we look to select not only sensors that are within our purchasing power, but also sensors that have a high demand in usage and application.

### **4.1.3 Environmental Constraints**

Today, more than ever, it is critically important to consider the environmental impact of the engineering profession, and manufacturing as a whole. It is imperative to push production and recycling of electronics towards a sustainable endpoint, and to be mindful of the extensive reach of the choices we make in

component selection and product design. To this extent, modular systems are favored in lieu of heavily integrated solutions. Having multiple assemblies connected via headers and cables provide methods of updating the prototype, or upgrading production models, without having to scrap large functional areas of the design. Smaller sub assemblies means that if a failure requires the destruction of a component, its damage can be more easily mitigated.

#### **4.1.4 Social and Political Constraints**

Underwater exploration typically won't have too many social or political constraints. The only possible issue we could run into is when treasure hunting is involved. Ships that have sunk while flying under the flag of a sovereign nation can still be claimed by that nation. The nation most well known for claiming ownership over any sunken treasure is Spain. The Spanish took gold, silver, and valuable gems from Latin America and transported them back across the Atlantic to Spain. Treasure hunters in the past who have found Spanish treasure have had to return the Treasure to Spain. An example of this happened back in 2012 when United States courts ruled that \$500 million dollars worth of Spanish gold and silver coins had to be returned to the Spanish government [44]. In 2007 an American treasure hunting company called Odyssey Marine Exploration found 594 thousand gold and silver coins. The company found the coins using remote-controlled deep sea robots to search 1,100 meters underwater on the seafloor. After a five year legal battle with the Spanish government was determined to be the rightful owner of the coins, and Odyssey Marine Exploration had to return the treasure to them.

#### **4.1.5 Legal Constraints**

There are a number of legal constraints to operating a metal detecting system and further constraints on removing objects that are found by the operator. Pursuant to Federal Regulations, Title 36, Chapter 1, Part 2, §2.1 paragraph a, clause 7, metal detecting is strictly prohibited in national parks and other federal lands, unless, under item i under clause 7, the detector is broken down to an extent that it is nonfunctional for the duration of the operator's presence on the land. This informs the design of the ROV and suggests that in order to maximize the areas that it can be taken, the metal detector coils should communicate with their driver and the submersible at large through a mating connector. This allows, when the legal need arises, the metal detecting portion of the device to be

disassembled and rendered temporarily unusable. The only exception to this is for approved scientific use.

State law does not prohibit metal detecting in state parks. At coastal parks however, the limits of legal metal detecting are the dunes and the waterline, which permits ambulatory metal detecting, but prevents any kind of submersible vehicle from operating as a detector. There are many different county restrictions on metal detecting that range from bans on metal detectors, to restrictions on hole size when digging, as well as various limits on which terrains or areas are allowed to be traversed.

Private lands are allowed to be detected on without issue, as long as it does not affect protected plants or animals. No sites can be disturbed if they are known archeological sites.

Florida does not require a boating license, but in order to command a vehicle with a combined engine strength greater than 10 horsepower, a class must be taken to allow operation.

## **4.1.6 Health and Safety Constraints**

There are several health and safety constraints beyond the COVID-19 pandemic mentioned in section 4.1.1. These are intrinsic to the ROV system itself.

In the event of a battery failure, the lithium polymer chemistry presents a significant fire and noxious fume danger to the operator. Care must be taken to charge and discharge these packs per manufacturer instruction, and to avoid piercing them or submerging them in water.

Head mounted displays can create great feelings of nausea or vertigo if improperly calibrated, or if the operator is more sensitive to symptoms of car sickness or sea sickness. Setting a correct interpupillary distance with the display's lenses, and selecting the proper lenses for a user, helps to combat this. Beyond the immediate discomfort of nausea or vertigo, operating a device adjacent to open water, any dizziness could lead to operator submersion, and it is important that the operator be able to swim in this event.

## **4.1.7 Manufacturability Constraints**

The most obvious manufacturing constraint for this entire project is making sure everything works while under water. Not only is waterproofing a major concern

but hydrostatic force when deep underwater could cause catastrophic failure as well. For every 10 meters below the surface of the water, an additional atmosphere of pressure is added from the water. So for the goal operating depth of 30 meters the static pressure experienced will be four atmospheres, or about 42 psi. This means that anything going underwater needs to be able to withstand that much pressure, and stay waterproof while doing so.

The design for the ROV itself will contain a dry container for all of the electrical components, a frame to connect motors and other accessories to, and the motors and accessories themselves. The dry container will need to be large enough to house the battery, the Nvidia Jetson Nano, the cameras, and any corresponding circuitry attached to a printed circuit board. Increasing the size of the dry container will make the ROV more buoyant due to all of the excess air in the dry container. The rest of the ROV will have to be heavier to counteract this additional buoyancy, as the ROV needs to be as neutrally buoyant as possible. If the ROV isn't neutrally buoyant, then extra power will be needed for the vertical thrusters to keep the ROV in the same spot.

It is also important to note where the weight of the ROV is located. If the center of mass for the ROV is located above the center of buoyancy, the ROV will have a tendency to flip over. If the center of mass for the ROV is located too much lower than the center of buoyancy then ROV will have a difficult time rolling. For our purposes we do not need our ROV to be able to roll too much, so extra weight will likely need to be added to the skids at the bottom of the ROV in order to keep the ROV neutrally buoyant while also keeping the center of buoyancy low. If our ROV isn't buoyant enough, then floats will need to be added to the top of ROV to keep it neutrally buoyant and keep it from tipping over.

The motor placement is important as well. The two thrusters that are used for forward and backward motion need to be on the same horizontal plane as the center of mass of the ROV. Placing these motors above or below the center of mass of the ROV will cause the ROV to pitch up or down depending on where they are placed in relation to the center of mass. The vertical thrusters need to pay attention to the center of mass as well. If they are too far forward or behind the center of mass the ROV will pitch.

## **4.1.8 Sustainability Constraints**

The ROV should be designed and constructed so that it is able to be reused multiple uses without needing servicing. The only part of the ROV that should

require any form of maintenance is the battery, and all the battery should need is to be recharged before each use. Because of this, the battery needs to be easy to charge, that could either mean that the battery has a recharging port that is easy to get to, or that the battery itself is easy to take out for its recharging needs. If there ever is a mechanical or electrical problem with the ROV there needs to be a way for easy access to the internal components so that repairs can be made. This will ensure that just individual components are replaced, rather than having to replace the entire ROV.

### **4.1.9 Ethical Constraints**

An ROV outfitted specifically with sensors for water quality and observation of natural phenomenon may not run afoul of any ethical constraints in and of itself. However, when exploring waterways it is important that the natural ecosystems remain undisturbed. This includes destruction of natural monuments and features, excessive disruption of local wildlife, and leaving behind material that is not biodegradable. There is possibility to mar natural resources by impacting them with the device, as well as unguarded propellers striking wildlife. Scars can commonly be seen on manatees that have been struck by boat propellers, and it is for similar reasons that we guard the propellers on our device.

Furthermore, creating a system that has the capability for locating and re  
AAGUH

### **4.1.10 Application Constraints**

Our application which controls the entire ROV system will be developed using the Robot Operating System on Ubuntu Linux. Linux is a widely used operating system with open source development and is available and most devices imaginable. With its massive popularity and community support finding technical information and guides on this technology shouldn't be a major issue.

## **4.2 Project Standards**

This section lists the different standards that impacted the design of our ROV. Engineering standards are the documents that give the characteristics and technical specifications that all products that use this standard must follow. Standards are used to ensure that the products and systems that all use this standard are able to interact with each other in a consistent and repeatable way.

Standards are also important for safety reasons. They make sure that potentially dangerous technologies are implemented in a safe and reasonable way.

### **4.2.1 Battery Standards**

The *IEEE 485-2010* standard lays out the recommended practice for sizing lead-acid batteries for stationary applications. This standard describes methods for maintaining, testing, and installing lead-acid batteries. The standard also helps to recommend other battery types depending on the specifications of the project. Unfortunately to get access to the official document, it would cost about \$200, but the standard itself is still useful to our project. Reading about this standard helps us to understand the things we need to be looking at in detail as we decide what type of battery we will be using for the project. We should discuss the methods of maintaining and testing different battery types to better prepare us for deciding which one would be best for our ROV.

### **4.2.2 PCB Standards**

Printed circuit boards are laminated stacks of a variety of materials. There are conductive layers and insulative layers and mechanically stabilizing layers, and in some cases, a layer may perform multiple duties. The conductive layer of a PCB is typically copper, but can be other materials. Above the copper is a thin layer of solder mask, an insulator designed to resist access to the copper layer by corrosive atmosphere or liquid ingress. The solder mask also prevents errant bits of solder falling and shorting nearby traces when populating a PCB with components.

Beneath the copper layer is typically a rigid combination of a fibrous material and epoxy. Two very common materials for the rigid inner layer are Flame Resistant (FR) and Composite Epoxy Material (CEM). This rigid layer can be made of woven glass (FR-4 and FR-5), cotton paper (FR-2 and FR-3), while impregnated with epoxy. The options also exist respectively in glass (CEM-3, CEM-4 and CEM-5) and paper (CEM-1 and CEM-2).

In order to accommodate more complex design needs, circuit board fabrication houses can create boards with more than 2 layers of copper. These are generally created in paired layers of copper around an intermediate substrate, and laminated and assembled together at the end. Board “layers” refer to the number



of copper layers in a design, and will always either be a single layer, or a multiple of two, because of this pairing in manufacturing.

There are also flexible PCBs that are constructed of a thin copper layer, a flexible solder mask layer (typically a sheet of a polymer instead of an applied epoxy paint) and an additional flexible polymer layer below the copper as the substrate. The benefits of flexible PCBs is the ability to have non-planar designs with great ease, as well as allowing for mechanically forgiving designs in areas of vibration or jointed connections.

In cases where great thermal dissipation is needed, metals can be used as the rigid substrate below the copper. There will be a thin layer of an electrically insulative, and thermally conductive, material applied to the metal before the adhesion of the copper, and this will allow electrical components to effectively use the PCB itself as a heat sink.

### **4.2.3 Bluetooth 5**

Bluetooth technology was unveiled back in 1994 and is used for short distance wireless communication for devices that are typically within 10 meters of each other. Bluetooth is used in all sorts of different applications, including laptops, smart phones, smart watches, wireless controllers, and wireless headsets. The Bluetooth Special Interest Group (SIG) is the organization which develops and distributes bluetooth technology. Bluetooth technology has evolved from point to point connectivity, which is typically used for always active applications such as with wireless speakers and wireless headsets, to Bluetooth Low Energy (BLE), which is optimized for low power data transfer. The Bluetooth SIG published Bluetooth 5.0 in December of 2016. Its main focus is to build upon BLE by doubling the speed, quadrupling the coverage area inside of buildings, and improving the broadcasting capacity by a factor of eight. The mandatory physical layer in Bluetooth 1.0 to Bluetooth 4.0 used Gaussian frequency-shift keying has a bit rate of 1 MB/s. Bluetooth 5.0 introduced two additional physical layers which work to double the speed and quadruple the range. Bluetooth 5.0 also introduced a feature called slot availability mask which reduced the amount of collisions between Bluetooth and other radio technologies that operate at the same frequency band. [45]

## **4.2.4 H.264 AVC**

H.264 is a video compression technology developed by the International Telecommunications Union and by the International Organization for Standardization/International Electrotechnical Commission Moving Picture Experts Group. The later group refers to H.264 as MPEG-4 or Advanced Video Coding (AVC). H.264 defines multiple profiles and levels, which give the user control over the maximum bit rates and resolutions used. H.264 supports up to 4k and 8k video playback. When streaming a video the data rate required to send every frame grows exponentially as the quality increases. An uncompressed 720p video stream can be over 200Mbps, whereas an uncompressed 1080p video stream can require as much as 3Gbps. [46]

Video streaming using this codec works because most video signals only have small changes between frames. Rather than send a completely new copy of each and every frame, only the changes to each frame are sent instead. Complete frames need to be sent at the start of every transmission, and complete frames known as key frames are sent every few seconds so that the video playback can keep track of where it is. [47]

## **4.2.5 360 Video Formats**

In order to encode omnidirectional video in a manner that is universally accepted by devices, the photosphere is warped into an equirectangular projection. This mapping has been used to represent the globe of the earth by cartographers for centuries. The usage of this format allows software to calculate the intersection of the viewing frustum with the sphere surrounding the viewpoint, and project that intersection onto the viewer's screen. In this way, all possible views from a single vantage point are stored, and a particular view can be selected at will by the user.

This format however, creates a great deal of unused video during storage and transmission. Large amounts of data are required to transmit unused imagery, and this imagery could ultimately end up behind the user. In the cases of stored video available for viewing afterwards, this allows for a high re-watching value in the media, as you can explore the same scene over and over. For live views of the world, where the captured omnidirectional video isn't stored, this data is captured, transmitted, and decoded, yet never used.

## 4.2.6 RoHS Standards

RoHS standards is abbreviated for Restriction of Hazardous substances and is also known as the original Directive 2002/95/EC, which originates from the European union dating back to 2002. It's main objective is to impose restrictions on hazardous components found in the electronics industry and electrical components. The current RoHS is RoHS 3 and starting from July of 2019 to now includes the following substance limitations:

- Cadmium (Cd): < 100 ppm
- Lead (Pb): < 1000 ppm
- Mercury (Hg): < 1000 ppm
- Hexavalent Chromium: (Cr VI) < 1000 ppm
- Polybrominated Biphenyls (PBB): < 1000 ppm
- Polybrominated Diphenyl Ethers (PBDE): < 1000 ppm
- Bis(2-Ethylhexyl) phthalate (DEHP): < 1000 ppm
- Benzyl butyl phthalate (BBP): < 1000 ppm
- Dibutyl phthalate (DBP): < 1000 ppm
- Diisobutyl phthalate (DIBP): < 1000 ppm [48]

It is imperative that our ROV does not exceed any of these amounts of hazardous materials in order to remain RoHS compliant.

## 4.2.7 CAT-6 Standard

A Category 6 cable is the sixth generation of twisted pair Ethernet cabling and proceeds it's predecessor in cross talk and system noise. In order to transmit signals according to typical Cat 6 standards, jacks, patch panels, patch cables, cross-connections, and cabling must match the standards defined by the Electronic Industries Association and Telecommunications Industry Association. Also, Cat 6 cabling is backwards compatible with the previous models. [49] [50] Our specific Cat 6 cable on hand is an unshielded twisted pair that includes 26AWG stranded, copper conductors. It's made of 100% pure bare copper, which makes it compliant with the UL Code 444 and National Electrical Code TIA-568-C.2 fire and safety standards, and has 550MHz bandwidth [51].

Our current dilemma lies in making our current Cat 6 cable able to handle being submerged underwater for a long duration. Typically, one would want a shielded Cat6 wire that's gel-filled or 'flooded'. The wiring would exceed TIA/EIA-568-C.2, CSA and ISO/IEC 11801 specifications. [52] We'll continue to explore alternatives

into making our current wire waterproof and may resort to buying a new Cat6 cable if we don't reach proper standards.

## **4.2.8 I<sup>2</sup>C**

I<sup>2</sup>C stands for Inter-integrated Circuit and it is used to connect multiple slave digital integrated circuit chips to one or more master chips. It is only intended for short distance communications within a single device. Only two signal wires are used to exchange information. I<sup>2</sup>C supports up to 1008 slave devices and is capable of supporting a multi-master system, which allows for more than one master device to communicate with all devices on the bus. Most I<sup>2</sup>C devices communicate at a rate of 100kHz or 400kHz. For every 8 bits of data sent an extra bit of data is sent as well for the ACK/NACK bit. Messages in I<sup>2</sup>C are broken up into address frames and data frames. Address frames contain where the master indicates where to send the information to. Data frames are 8-bit messages passed either from master to slave or from slave to master. Multiple data frames can be sent with just one address frame. [53]

## **4.2.9 UDP/IP**

User Datagram Protocol is a communication protocol used for time-sensitive transmissions on the internet. Typically UDP/IP is used for video playback or for online multiplayer video game sessions. UDP does not have the error checking or ordering functionality that TCP has. As such, it is best utilized when error checking is not needed and speed is the most important quality. UDP headers consist of four two byte fields, they are the source port, the destination port, the UDP length, and the UDP checksum. The UDP header is not processed by any intermediate systems in the network, instead they are delivered to the final destination in the form they were originally transmitted in. [54]

## **4.2.10 STL**

The STL file format is a 3D model file format which is commonly used for 3D printing. STL stands for Stereolithography, although it is sometimes referred to as Standard Triangle Language or Standard Tessellation Language. The STL file gives the geometry of the surface of an object's surface. This information is created using a process known as tessellation. This process consists of tiling a surface with geometric shapes so that there are no gaps or overlaps. The STL file format uses 2 dimensional triangles to cover the surface of a 3D model, and then

to record the information about the size, shape, and location of these triangles into a file. The file itself stores the coordinates of the three vertices of each triangle, as well as the vector normal to the face of the triangle, facing outwards from the surface. STL has some special rules for the tessellations and the way information is stored. Each triangle in the tessellation must share two vertices with neighboring triangles. The vertices of the triangles must also be listed in counterclockwise order when facing the object from the outside. This ordering follows the right hand rule. This redundancy helps to ensure that STL files aren't corrupted. If a triangle has its vertices listed in the wrong order then the 3D program will know that the file has a program and can attempt to correct it.

## **4.2.11 Power over Ethernet Standards**

There are several standards for PoE that define the amount of power that is able to be transmitted over an Ethernet cable. These standards also state how many of the twisted pairs the PoE must be limited to in order to function properly. Since the first IEEE standard for PoE was adopted, there have been others that continue to push the power limits per cable and device. These standards that have been set will greatly help us with finding the right devices for using PoE. The standards make it much easier for the consumer to see what power outputs they can expect from a given device. We can also verify that the products we use are meeting the standards that they claim to meet. Below is a short list of the standards that impacted the PoE injectors we looked at for the project:

IEEE802.3af - Supplies 15.4 Watts maximum to a device, where only 12.95 Watts is guaranteed to make it to the powered device due to losses along the cable. The 15.4 Watts is calculated as minimum 44 VDC and 350 mA.

IEEE802.3at - Allows for the use of 4 pairs and supports higher power to powered devices. This standard encompasses the previous standard (802.3af) as it can also use only 2 pairs. This standard allows for up to 30W per port which practically doubles the previous output due to the fact that the wires used doubles.

There are other standards that were made to increase the power output even further for some devices, but for our usage we will not need more than 15-30 Watts for powering our features. It is also important to note that these standards are changing as time goes on. These standards can get better in more ways than a simple power increase per port on a switch.

## **5.0 Project Design**

Bottom Feeder is going to be a collection of features that are combined in a manner that allows the user the freedom to explore the waters in a new way. This means that the ROV's principal duties are locomotion and observation. Following this are tasks involving manipulation of the environment. In order to facilitate these goals, a physical design must be conceived and built. The discussion of the design will be broken up into several parts in the following sections.

### **5.1 Hardware Design**

In order to move freely underwater, the design must include several mounted thrusters. These can be mounted orthogonally, and their axes not passing through the center of buoyancy, in order to affect a maximum amount of yaw, pitch or roll, through operation. If they are oriented similarly, but not orthogonally, they can cancel each other's moments, and propel the craft in a manner more akin to translation.

These thrusters, and the batteries to power them, must not overly obscure the cameras. Special challenges arise with the addition of omnidirectional video. The creation of this media benefits greatly from cameras being mounted physically close to one another, so that their points of origin trend towards coincident. In a more intuitive constraint, it is also important to not mount excessive amounts of equipment in direct view of the cameras, lest we unnecessarily create blind spots for the operator.

#### **5.1.1 Pressure Sensor Design**

The pressure sensor chosen will output its information in analog fashion, rendering a voltage on its signal pin representing pressure at the transducer. This voltage is offset downwards, attenuated with a resistor divider and buffered through an operational amplifier before presenting it to the microcontroller's pin. Sampling this voltage can be done with the MSP430G2553, and its onboard digital to analog controller. Sampling is done twice a second, as more frequent samples won't generally improve the quality of the system. The limited speed of Bottom Feeder is the limiting factor on how quickly samples from the pressure sensor will be required. Onboard the MSP430 microcontroller, this voltage is read as a 12 bit unsigned value. Ranging from 0 at the surface and 4096 at its full depth of 105m, and considering that pressure scales linearly with depth, this

integer value is divided by 39, and the resultant number is the depth in meters. This number is sent over a UART connection to the NVIDIA Jetson Nano and then further reported to the end user.

### **5.1.2 IMU Design**

The BNO005 Inertial Measurement unit connects to the microcontroller using the I<sup>2</sup>C communication standard. When the IMU powers on it needs to be calibrated. This is done by rotating the IMU around in a circle. Fortunately, this calibration only needs to be done once, and the calibration data can be saved in a nonvolatile memory location, such as on the SD card in the Nvidia Jetson Nano. Once calibrated, the provided libraries for the IMU allow for seamless data acquisition. The BNO005 is able to give the absolute orientation in euler vectors or as quaternions, the angular velocity vector in radians per second, three axis acceleration in meter per second squared, and the magnetic field strength vector used for compass headings in micro Teslas. The IMU is going to be used to ensure that the ROV stays stable while in the water. When the operator isn't giving the ROV any inputs the ROV should stay in place while in calm waters. This means the linear and rotational acceleration vectors will need to be reported to the microcontroller so that any adjustments can be made using the motors. The magnetic orientation will be pulled from the sensor as well and sent to the surface station so that it can be displayed on the head set's heads up display.

### **5.1.3 LED Illumination Design**

The CREE XPL-665-1 LEDs that we are using for the lights are high-power LEDs. They will take up to 3 Amps of current and depending on how much power they draw, the brightness of the LED will change. In the datasheet for these, the brightness is 200 lm/W at a current of 350 mA This means that we need to ensure that we have the current draw we need for a specific brightness. The LEDs are able to output about 1140 Lumens at their maximum power rating which is slightly higher than we will need. We could potentially have brightness control by allowing the user to directly change how much current the LED is getting using a potentiometer. We intend to at least have the lights to be controlled by a simple on/off switch.

It is important that we keep the LEDs dry and in the ROV housing outside of the camera bubbles. If the LEDs are inside the bubble with the camera it is likely that the cameras will see some of the light reflected back from the inside of the

housing. We will also be adjusting the angle of the LED by using a reflector as well. This will keep the light aimed in the best direction to allow for maximum visibility. If we have the time to implement variable brightness, it may also allow the user to reduce the light that is reflected back from particles in the water that tend to reduce visibility in the dark. Adjustments will be made to the brightness if we run into any issue like this.

## 5.1.4 Submersible Embedded Design

The embedded electronics designed for the ROV will facilitate the Jetson Nano's ability to manage peripherals. The hardware will allow for mating with multiple batteries, conditioning their output, operating the metal detector, and controlling the underwater illumination and the thruster motor driving. The Jetson Nano will communicate with an MSP430g2335 microcontroller on this board, that will in turn communicate with H-Bridge and general discrete logic components to accomplish this goal. The Jetson's 40 pin GPIO header, the MSP430 and some digital logic not covered elsewhere can be seen in *figure 37*.

The MSP430 will communicate with the metal detector's digital interface over a discretely implemented serial interface. These are annotated as MOSI, MISO, EN, CLR (active low), and SCLK in amber, to the MSP430's pins 7, 6, 12, 13, and 14 respectively.

The pressure sensor makes use of the onboard analog to digital converter available on pin 31. In order to maximize the available peripherals to communicate with, configuration information for the motor drivers is shifted out into a register, bringing the requisite number of control lines down from 8 to 3.

To simplify reprogramming of the MSP430 we have broken out the programming headers in an effort to match the FET connector on an MSP430 launchpad development board. This allows for the use of Code Composer Studio's advanced real time debugging capabilities to be taken advantage of.



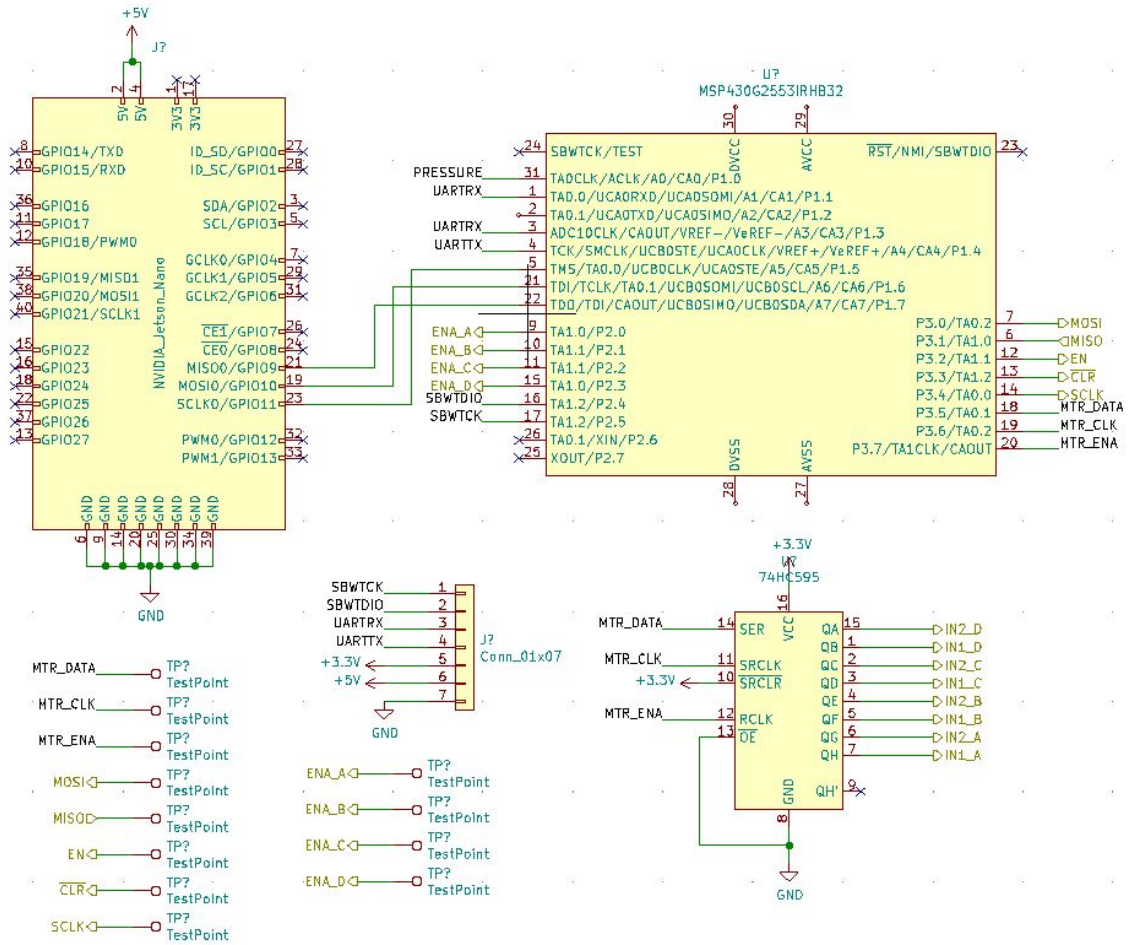

Figure 37: The connections between the Jetson, the MSP430 and discrete components

In figure 37, it can also be seen that test points are used generously in this design, providing ample opportunities for the developers to troubleshoot issues that arise over the course of component population and initial testing.

## 5.1.5 Surface computing Design

Surface computing will be handled by an application running on a Raspberry Pi. This will mate with the Oculus Rift HMD and pair with the Playstation 4 wireless controller, and communicate with the submerged systems over Ethernet. The Raspberry Pi will be accompanied in its case by a lead acid battery as well as a Power over Ethernet injector.

Computation done on this device will include presenting the video stream to the HMD, without any graphical processing. It will also serve to collect data from the controller, package it into a JSON object, and serve it over TCP/IP to the underwater Jetson Nano. This will allow for minimal data processing and high throughput from the controller to the ROS process that will use it as input for its set points.

## 5.1.6 Motor Driver Design

For powering the thrusters we've elected to use the L298 H bridge driver from ST Microelectronics. Due to the thrusters requiring up to 3A of current during normal operation, it is recommended that we configure both halves of the dual driver to function in parallel. Add to this that we desire bidirectional operation, we use a fast recovery schottky diode rectifier in order to suppress back-emf from the motors, preventing damage to the bridge driver. The two application schematics from the datasheet are found below in *figure 38*.

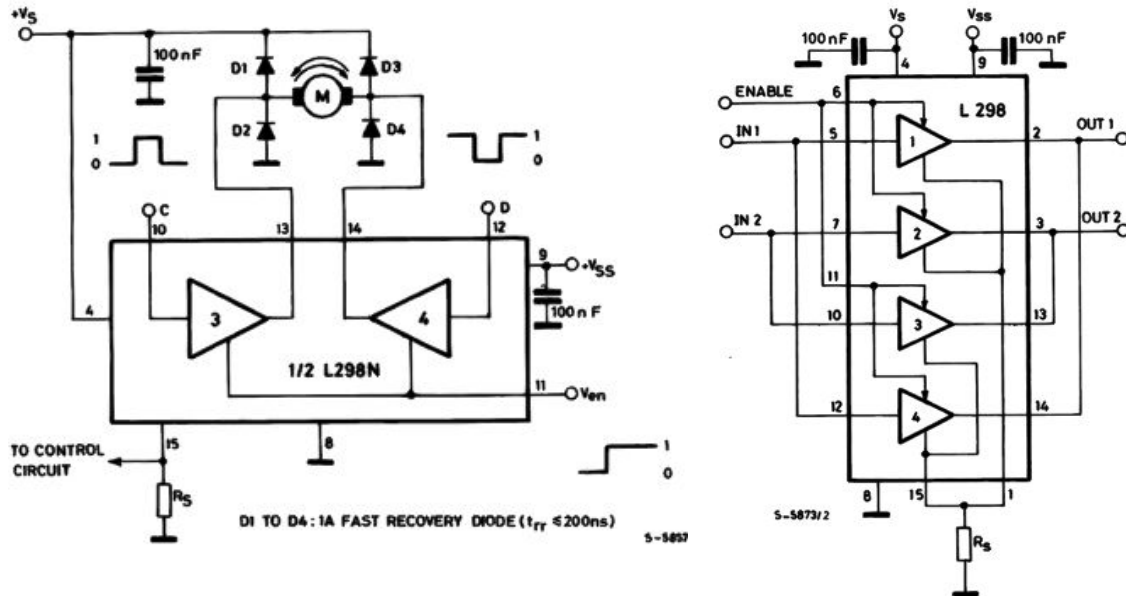

*Figure 38:* Application schematics from the L298

The result of these application schematics is a parallel driver circuit configured to manage a bidirectional brushed motor. Each of the four motor drivers takes two digital inputs, annotated as IN1\_X and IN2\_X, and an ENA\_X input for enabling the selected configuration. When IN1\_X and IN2\_X are both set to high by the controller, the motors will undergo active braking, when only IN1\_X is high, the

motors will spin either clockwise or counterclockwise, and holding only IN2\_X high will result in the alternate direction of motion.

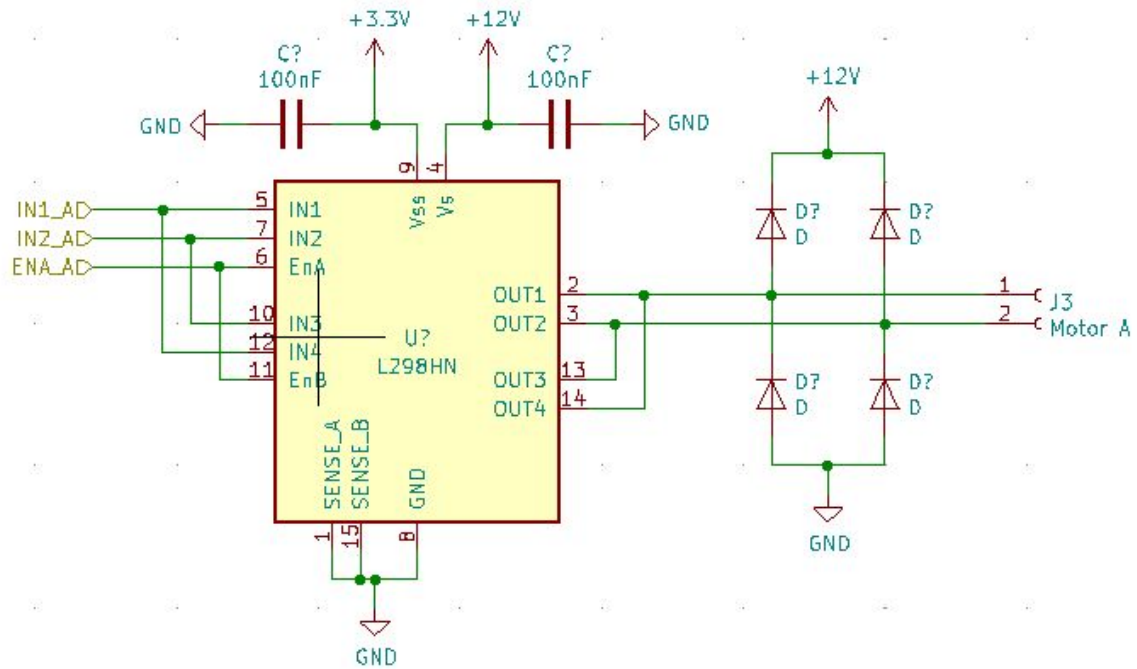

Figure 39: The resultant schematic of the motor driver subassembly.

## 5.1.7 Power Supply Design

The ROV will have several low power components that need to be powered by an 11.1 Volt LiPo battery. For these components to be properly powered we have to regulate the voltage coming from the battery and properly convert it to the correct voltage/current for the components. For example, the Jetson needs a 5 Volt input, and the microcontroller needs a 3.3Volt input. This voltage regulation is done in the schematic seen in *figure 40*.

Our low power domain makes use of the TPS565208 regulation IC, that is able to provide an output potential ranging from 0.76V to 7V. This provides an opportunity to the designer to minimize the size of the bill of materials, by reusing the same component in order to provide both 3.3V and 5V potentials to the digital components. The IC uses a reference signal provided to the voltage feedback pin, annotated in schematic as VFB. This IC creates its output based on equation 3 as found in the datasheet. These schematics are designed to produce no more than 4amps, as the NVIDIA Jetson Nano loaded with cameras should

draw 2.5A, and the MSP430 and associated logic ICs contribute a few dozen milliamps each to the load.

$$V_{OUT} = 0.760 \cdot \left( 1 + \frac{R1}{R2} \right)$$

Equation 3: This equation guides selection for feedback resistors.

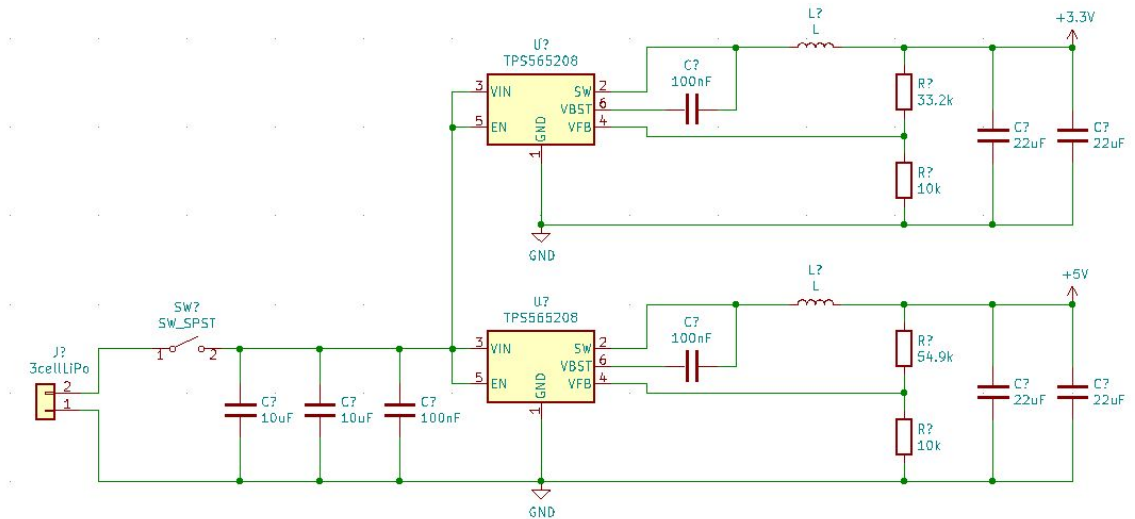
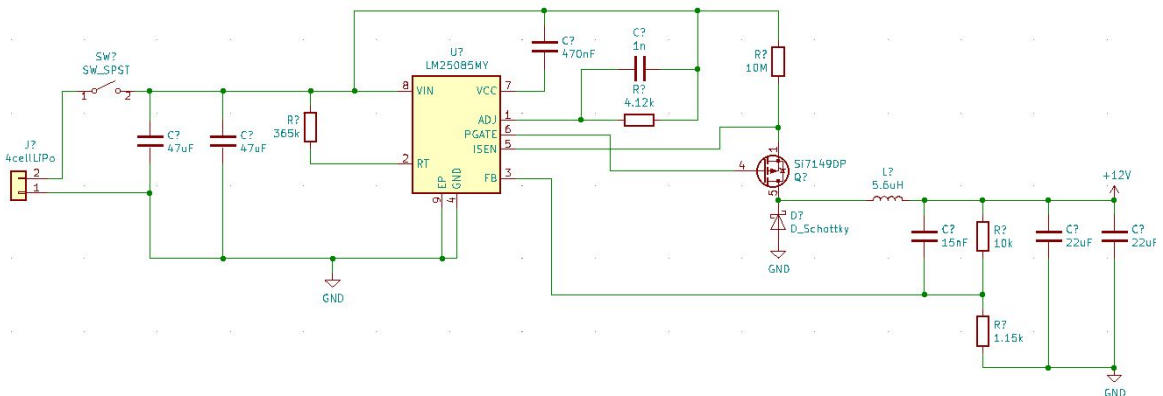

Figure 40: The voltage regulation for the low power electronics systems

To maintain a relatively clean electrical domain for the digital electronics, we separated the thruster driving controls to a separate power supply. These two domains' grounds will be linked through an inductor to prevent ripples on the ground plane to perturb the digital circuits. The high power circuit is described below in figure 41.



*Figure 41: The high power motor supply.*

The high power design elects to use an LM25085MY buck switching controller that manages the duty cycle of a P-FET rated to carry up to 70amps. Maintaining this switching creates a small ripple, smoothed by the output capacitors, and shouldn't create an issue for the motors, that will be under their own PWM influences. When using Texas Instruments' WebBench designer, we specified that this high power circuit should be able to deliver 10 amps. Practical tests of the thrusters have shown that under full load, at 100% duty cycle, they pull up to 2.1A each, and we've overrated this to find the 10A maximum.

The LM25085MY offers several features that led to its selection. The design allows for a predictable noise on the outgoing voltage rails. In the case that water creates a short between the positive supply potential and ground the IC features an integrated thermal shutdown, should the power consumed by the aqueous component create an undue burden on the regulator.

## **5.1.8 Metal Detector Circuit Design**

An elementary method of metal detecting is to look for changes in the inductance of an area. As a coil of wire is moved towards conductive elements, its inductance will change. We harness this change by making an RLC oscillator with hysteresis created with the comparators and latch in the LM555 IC. This oscillator is presented in *figure 42*. As the inductance increases in this circuit, the frequency of oscillation also increases. In audible frequency ranges, this change in frequency can be perceived as a change in pitch.

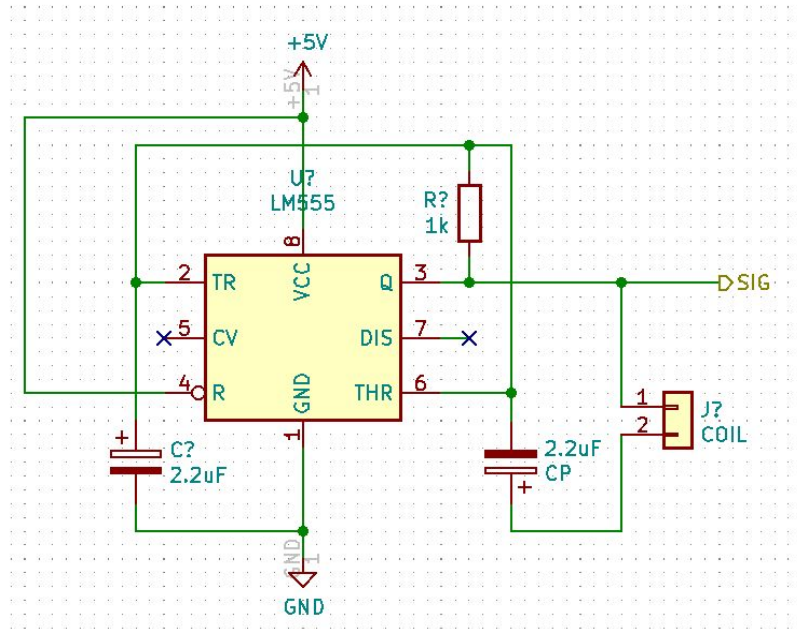

Figure 42: RLC oscillator circuit using the 555 timer

In order to more easily integrate with the microcontroller, this pitch is converted through a pulse counting circuit, and latched into parallel in/serial out shift registers. This creates a frequency to integer converter circuit, and allows for a SPI style interface to read this data. This counting circuit is seen in *figure 43*.

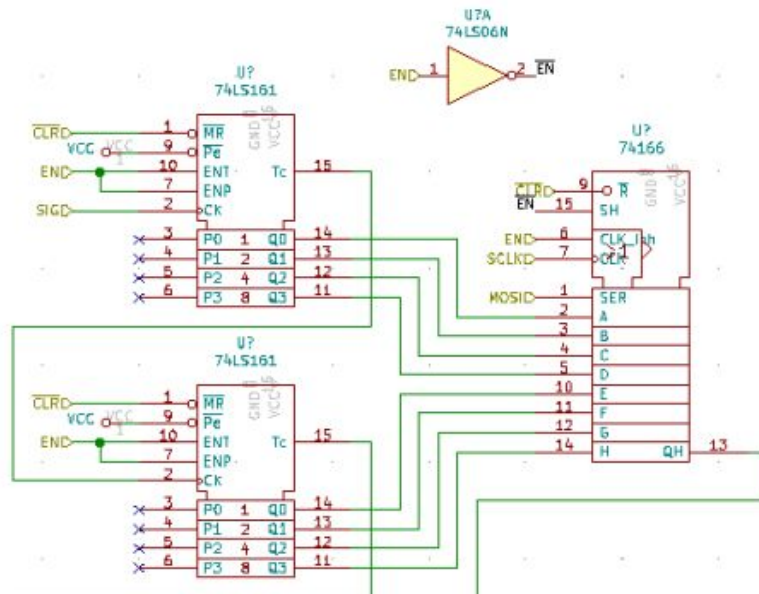
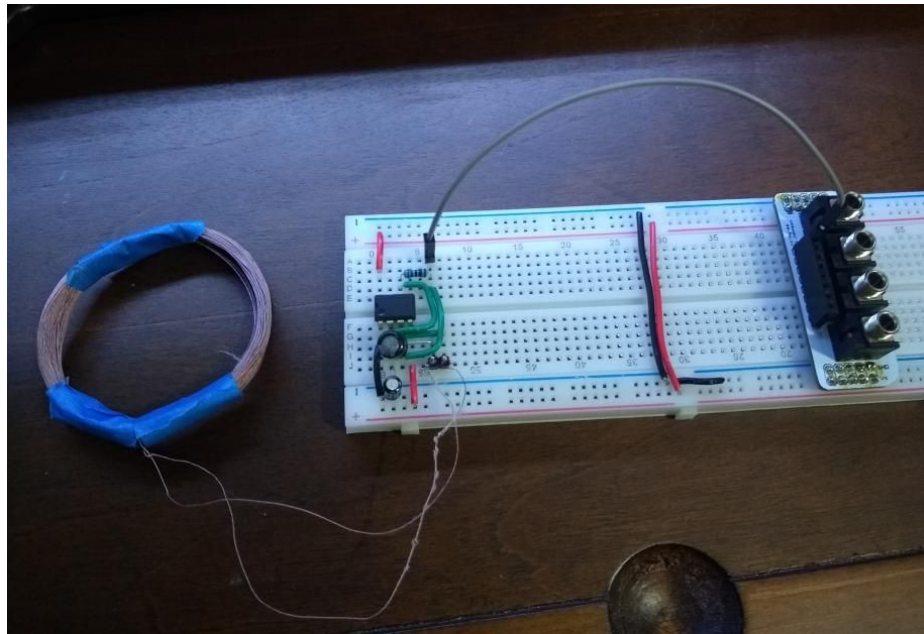

Figure 43: This pulse counting circuit provides a SPI interface to measure frequency

The microcontroller pulses a read signal high for a fixed period, allowing the oscillator's signal to toggle the counters, and when pulling the read signal low, that recorded count is latched into the shift registers. Then the recorded number of peaks from the circuit can be read into the microcontroller as a 16 bit value. This allows for granular control over the recording duration, and a broad range of possible output values. After normalizing the algorithm to a few neutral measurements, the system can observe for deviations from this calibrated value. When the observation deviates by an appreciable amount, the operator is alerted that there may be an item of interest in the range of the detector.

The detector oscillator section of this has been prototyped on breadboard prior to the initial PCB layout. This can be seen in *figure 44*.



*Figure 44:* Breadboard prototype of metal detection circuit

Initial qualitative tests have proved fruitful with this design.

## 5.2 Software Design

While this project creates a great deal of electrical and mechanical processes and components, the glue that holds these systems together lies in the software we will produce. In order to control the ROV, be able to interpret its data and immerse oneself in its point of view, and to allow the ROV to manage its own minutiae, multiple software systems must be written. These applications will



interact with each other on a single device, and across a wired network, and through traditional embedded serial methods.

## 5.2.1 Omnidirectional Video Processing Design

In order to process the two camera feeds and create an equirectangular video stream, we will make use of the NVVIA Jetson Nano's graphics processing unit. Accessing the camera data via MIPI-CSI requires using the EGLStream libraries from NVIDIA's own JetPack Camera API. These allow for access of the data via the OpenGL Shading Language (GLSL). This video feed available has been experimentally recorded up to 100 frames per second (fps), although at a sacrifice of quality. At full resolution, 30 fps is achievable while sampling both cameras. The raw view from these wide angle cameras is visible in *figure 45*.

In GLSL, slices of the source texture, the camera feed, can be distorted and mapped to new coordinates of the framebuffer, or the outgoing video stream. Having few, fixed translations for these texture maps allows very optimal usage of the Maxwell GPU on the Nano. Using the GStreamer API, this framebuffer can be compressed using the H265 algorithm, to limit bandwidth usage, and then streamed via UDP to the surface station for presentation to the system operator. The speed at which these transformations can be achieved and presented to the networking functions for streaming is yet undetermined.





*Figure 45:* An example 200° field of view image available for processing

The surface station will forward the H265 video stream to the HMD, which comes from the manufacturer with the ability to decode this video stream and allow for immersive viewing of equirectangular video in a first person perspective by the wearer.

## **5.2.2 Microcontroller Code Development**

The microcontroller is responsible for all of the sensor data acquisition and for providing the logic signal to the DC motors. We are using the MSP430G2553 for our microcontroller which has twenty general purpose input/output pins and two clock signals. Using these two clock signals we can generate a pulse width modulation signal on the four pins used for control signals. The direction of a motor is controlled using two input pins on the motor driver circuit. Switching which direction the motor is spinning is done by switching which of these two pins is high and which pin is low. In order to save on the number of microcontroller pins being used a shift register can be implemented. The

microcontroller also comes with a ten bit analog to digital converter. This allows us to get the sensor readings as a number between 0 and 1023. All of this information can then be passed to the Nvidia Jetson Nano over the I<sup>2</sup>C interface.

### **5.2.3 ROS system development**

The Robot Operating System (ROS) is a robotics integration platform that contains a collection of tools, libraries, and conventions that help simplify the development of complex robotic behavior. The current version of ROS that is compatible with the Nvidia Jetson Nano is ROS Melodic Morenia. While it's called Robot Operating System, it doesn't replace the operating system on the Jetson Nano, instead it is installed on top of Ubuntu Linux. The main benefit for using ROS is that it provides a simple message passing interface that is able to communicate with many different devices. For our project, ROS is the backbone that allows us to transmit video and sensor data from the ROV to the surface, and then transmit bluetooth controller inputs back to the ROV in order to control the motors. The message passing interface of ROS is built on a publish and subscribe mechanism.

### **5.2.4 Class Diagram**

The class diagram for the entire ROV system is given below in *figure 46*. This diagram shows the relationship between all of the major classes and the methods and fields that comprise each class. All of the individual sensors connect directly to the microcontroller using the on board analog to digital converter. The motor drivers will also receive their control signals from the pulse width modulation pins on the microcontroller. The microcontroller itself will communicate with the main single board computer using I<sup>2</sup>C. Through this connection, the microcontroller will be able to relay all sensor information to the main single board computer, and the computer will be able to send thruster commands out. The cameras connect directly to the main single board computer, which then gets processed and encoded into a live streaming video format and sent to the computer on the surface. The surface station sends a video signal to the headset, and also receives controller inputs from the bluetooth controller while also sending a force feedback rumble response back.

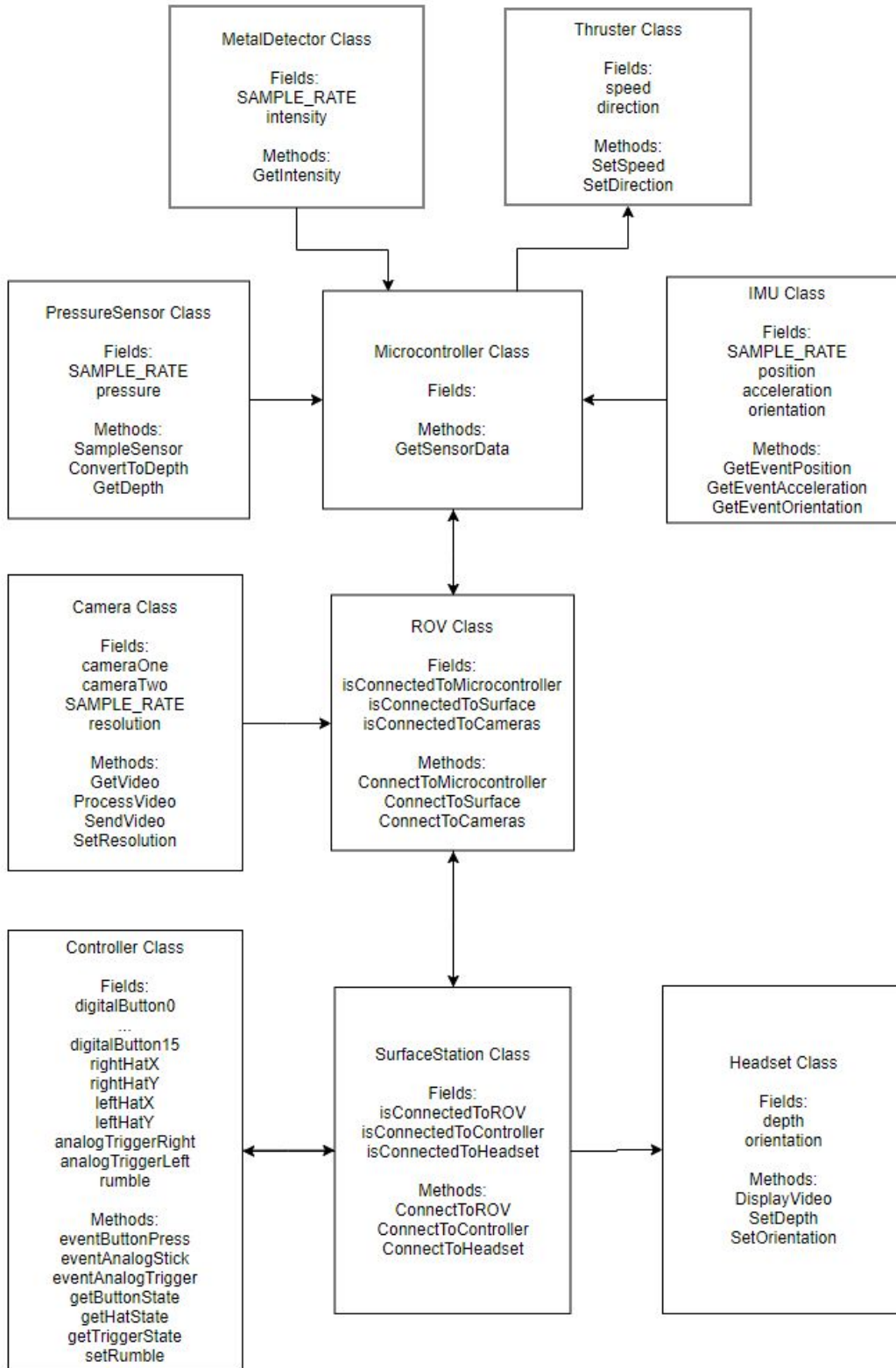

Figure 46: Class Diagram

## 5.3 Printed Circuit Board (PCB)

In order to operate the various peripherals beyond the NVIDIA Jetson Nano, a daughter board will be designed and constructed. This will contain voltage regulation for the required subsystems, drivers for motors and LEDs, and sensor interface circuits.

### 5.3.1 Schematic and PCB Software

To organize the schematic capture and board layout, a PCB CAD software package must be chosen that will allow for collaborative editing of files remotely. In addition to the collaboration management software, a system of tools must be in place to create the designs themselves.

Solutions to the first issue, regarding syncing progress and allowing for remote work, include Google Drive, Dropbox and Git. Each have benefits and drawbacks, and the general tradeoff between using Google Drive or Dropbox, instead of a Git solution is the convenience of an automatic solution, at the expense of being able to granularly control what is committed to the storage solution, and explicit labelling of every file and change added.

To create the designs for a PCB, an electronic design automation (EDA) package must be chosen. Several market leaders include EagleCAD, Altium Designer and KiCAD.

EagleCAD presents a great benefit in that it is a widely used solution, widely supported by both engineering firms and the manufacturers of components. Its proprietary formats are frequently found on manufacturer pages and allow for complex circuits and component information to be gotten and imported quickly. The free version allows for a 10cm by 10cm PCB, limited to two layers

Altium Designer offers similar benefits to EagleCAD, but offers enhanced high speed and EMF simulation tools in order to verify the design before manufacturing. There is no free version of Altium, and the license is prohibitively expensive.

The final solution in KiCAD offers a free EDA package without any arbitrary limits on layer count or footprint size. This software is free and open source, and because of that, functional updates to the software are prioritized over quality of

use, and many interesting or uncommon tools found in other packages, such as curved traces when routing a PCB, are not found in KiCAD.

## **5.3.2 PCB Manufacturing and Soldering**

Printed circuit boards can be made at any number of fabrication facilities around the globe. Ones used previously by team members include OSHPark, JLCPCB, and AllPCB. While overseas circuit board fabrication has the benefits of fast turnaround at a rock bottom price point, given the global turmoil with COVID-19, a US supplier may have a more stable shipping system in place, avoiding concerns about stalls at the border due to health concerns. In opposition to that concern, there may be large delays and backlogs at American suppliers of PCBs, and certain areas of the nation may remain under Stay-at-Home or Shelter-in-Place orders, preventing any domestic manufacturing of these devices. In that case, we may be forced to go overseas to suppliers.

## **5.3.3 PCB Design**

In order to draw the schematics for our project, and to lay out the printed circuit board, we have chosen to use KiCAD, which is a collection of EDA softwares. Of the included packages, we are using Eeschema for schematic capture and PCBNew for layout and routing. The myriad design files are housed in a Git repository along with our software, and all team members have access to this cloud based version control system.

## **5.4 System Housing Design**

In order to sketch ideas for design, a rapid modeling system was employed through the use of OpenSCAD. Some preliminary sketches of possible form factors are below in *figure 47* and *figure 48*.

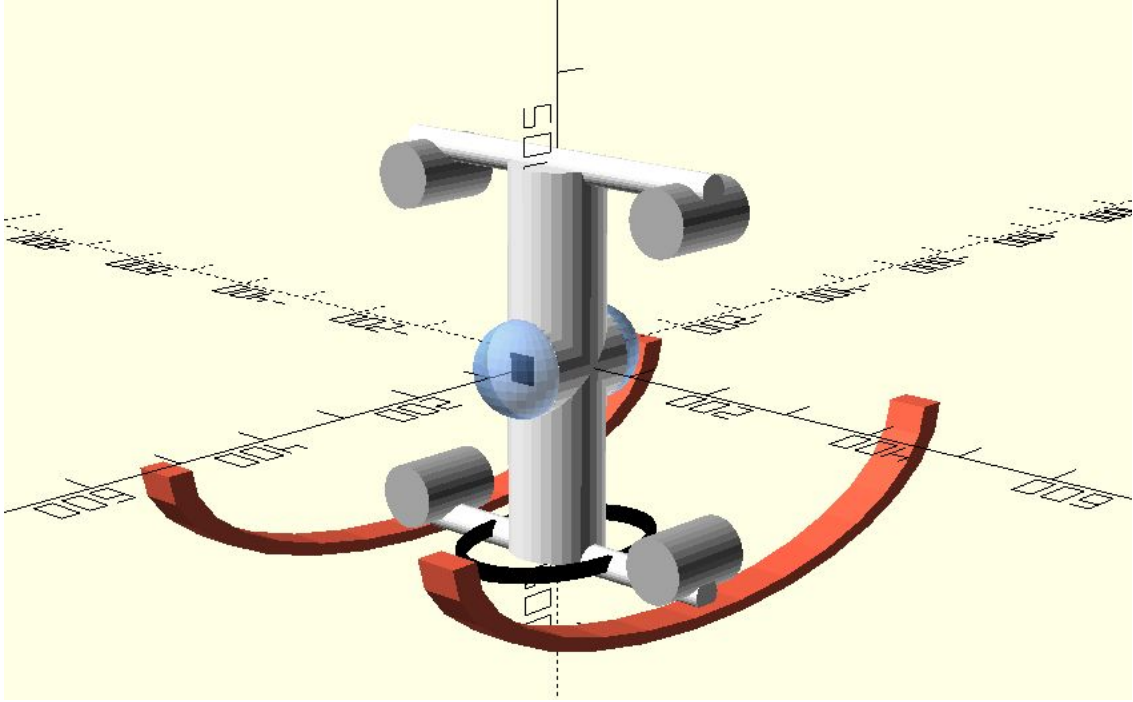

*Figure 47: ROV Design made of PVC with metal detector*

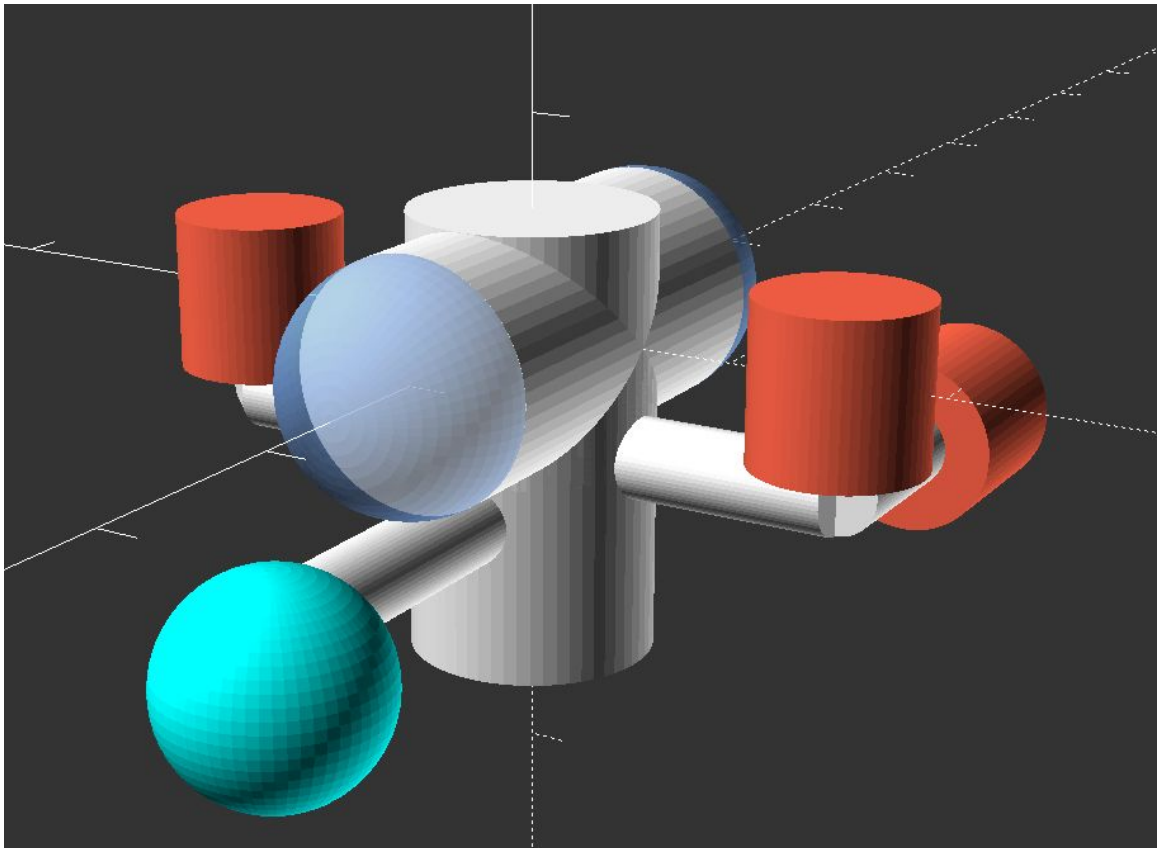

*Figure 48: A design featuring geometries available locally and thruster configuration noted in figure 13*

## **5.4.1 Materials**

Materials used in the construction of the ROV's mechanical aspects will be limited to PVC plumbing components, 3D printed assemblies, as well as acrylic components where transparency is an integral aspect of the design.

## **5.4.2 Modeling Software**

We will be using Autodesk Fusion 360 modeling software for all of our three dimensional modeling needs, and OpenSCAD for much of our prototyping and idea sketching.

Autodesk Fusion is free for students and is very similar to 3D modeling programs that we have prior experience with such as Solid Works. Autodesk Fusion 360 has an extensive amount of community support, making it easy to find tutorials and find answers to any specific questions that we might have. Fusion 360 has a cloud saving system which ensures that our designs are never lost, and has a built in function called teams which allows for us all to see and edit our designs. Fusion 360 has a built in 3D print function which converts the 3D model into a widely accepted .stl file. This filetype is used by all popular 3D slicer programs and works well with the 3D printer that we have access to. For this project the testing case for the 3D/stereo vision cameras was designed using Fusion 360. [55]

OpenSCAD's programmatic take on solid modeling is geared towards software developers and those looking to work strictly with primitive volumes and their intersection, union, etc.

## **6.0 Testing**

Testing will be performed in several locations simultaneously. Each subsystem will be tested by the team member designing it, and ultimate construction and testing of assemblies will be performed as social distancing protocols relax and more in person contact is permitted by law. Due to restrictions on international shipping and commerce, some testing and quantitative analysis will be made to the best effort of the team, and home made solutions will be used in the interim period, in lieu of being able to access more robust and well equipped facilities



during the quarantine that will dominate the overall working period of this project.

## **6.1 Component Testing**

While larger assemblies of systems will not be tested, individual components and circuits will be verified to perform adequately. When possible, components purchased will be breadboarded into minimal driver circuits and then subjected to reasonable loads or conditions. If not the component is not through hole, does not have 0.1" divisible spacing, or testing precludes the possibility of using a breadboard, an alternate solution will be pursued. This includes purchasing the component on an evaluation board but could also include designing our own breakout board.

### **6.1.1 Pressure Sensor Testing**

Testing the pressure sensor will require immersion in water, and therefore requires that any circuit on a standard breadboard be at a distance. The component uses long leads to allow access to the voltage potential created as an output. The ADC circuit can be safely above the surface of water, while the sensor is submerged. In an effort to keep the back side of the sensor dry, the sensor will be mounted in a small enclosure. This enclosure can be mounted to the end of a PVC pipe, with the wiring run through it. By marking off on the pipe the distance from the sensor head, the pipe can be submerged to different depths and the voltage potential recorded. This will allow us to create a mapping of voltage onto pressure, knowing the density of the water we're testing in. Having an input that can be read as pressure allows us to efficiently map that to depth in both fresh and saltwater, knowing the densities of both fluids.

### **6.1.2 IMU Testing**

The inertial measurement unit gives positional feedback to the ROV controller and allows for the ROV to keep level and stable while in use. The testing procedure for the IMU is simple and straightforward. The Adafruit Sensor Library contains testing code which allows you to move the sensor around in physical space and see how a digital 3D object moves in response to that [56]. By running this test code we can verify that the IMU is operating properly and that our single board computer is receiving data properly.



### **6.1.3 Power Testing**

Each feature needs to be tested on its own to ensure that they are functioning properly. We can do this by breadboarding each of the components (the LEDs, microcontrollers, etc.) to verify that they operate normally. Once all the components are functioning correctly, the regulator circuits need to be thoroughly tested. This will be done by putting load resistors in place of the components receiving the regulated output, and inputting a voltage of a range similar to that of the battery to the input end of the voltage regulator. If the voltage and current across the load is in the acceptable range then it should be safe to connect the actual components. We do, however, need to be certain that the regulators are correctly limiting the voltages and currents to the values that are within the safe operation specified by the components. If we fail to test this, then we will have to buy more parts and we will lose time. We also should test that the voltages that we expect to be DC are stable voltages.

### **6.1.4 Bluetooth Testing**

The wireless controller we are using connects to the surface station via bluetooth. To ensure that the controller is working properly and that the bluetooth connection established a test code will need to be written to test all of the features of the controller. The test code will need to test that all of the digital buttons are working, that the two joysticks give correct values in both the x and y directions, and that the two analog triggers give an appropriate analog reading when pressed. The controller we are using is also capable of force feedback, often referred to as a rumble feature. This feature can be used for sensor feedback, and the metal detector circuit can make solid use of this feedback. As such, the rumble feature will need to be tested as well to ensure that we can use it to tell the difference between a metallic object that is at the edge of the metal detection range and an object that is right next to the metal detector.

### **6.1.5 Head Mounted Display Testing**

Headset testing consists of viewing various sources of video, and confirming that they are real time and responsive to head movements. Streaming online content from an uncontrolled API is the first stage of testing. Streaming a recorded file from a local source is the second milestone. Lastly, streaming content from a

local live source is the final challenge. Once this has been achieved, the bulk of visual work to be done rests on camera feed manipulation.

A service that would be beneficial to the system operator would be a heads up display (HUD) that overlays relevant sensor data from the device in an easy to consume manner. These displays have been used for pilots since the 1960s, and offer an unobtrusive method of integrating the natural view with critical system updates [57]. The Oculus Rift API provides access to adding static elements overlaid on a video stream, and this is the method chosen to create the HUD. Elements of the HUD will include thruster status, including direction and magnitude, current depth, the orientation of the Bottom Feeder, and the status of the metal detector's activation.

## **6.1.6 Metal Detector Testing**

In an effort to test the metal detector, we have assembled a variety of materials we can use to calibrate its response to metals we are likely to encounter in the field. We will be using a crescent wrench to test identification of ferrous materials. In order to test precious metals, we have an ounce of 0.900 gold, and a large amount of quarters and dimes that predate the 1964 switch away from a high silver content. We also have acquired a pair of fishtanks we will use to hold fresh and saltwater, allowing us to test the metal detector in both water conditions and verify that it responds to metallic objects appropriately.

## **6.1.7 Geiger Counter Testing**

Our goal with detecting radioactivity in the environment is limited to detecting radon dissolved in the water. Water is intrinsically very good at interacting with, and thereby blocking, alpha particles. It can be surmised that at operating depth, if radioactive activity is detected, it signifies the presence of dissolved radon, or perhaps uranium salts. In order to test the sensor, we have several radioactive samples at our disposal, ranging from a pair of uranium doped glass pieces to a piece of uranium ore, these are visible in *figure 32*.

Alongside our ROV's sensor, we can place a commercial Geiger counter, and record the response to our test materials in microSieverts per hour ( $\mu\text{Sv/h}$ ), and use this information to to calibrate our sensor and have a threshold to compare against.

## 6.1.8 Thruster Testing

Because the thrusters have to be modified from submersible bilge pumps without any proper documentation, they have to go through testing in order to find out how much thrust they can produce. The basic way to run this test is place the thruster underwater and connect it to scale. The change in weight on the scale is the amount of thrust the thruster provides. A single 1100 gallon per hour pump was purchased for testing purposes. *Figure 49* below shows the completed testing rig for our thruster design. The motor is placed at the bottom of a stick which is free to pivot at the center. At the top of the stick is a hook which connects to a hanging scale. The mounts for the motor, the pivot stick, and the scale were all designed and 3D printed by us. The propeller was also designed and 3D printed by us, and different propeller designs were tested using this test bench. The motor was connected to a multimeter so that a relationship between amps and force can be ascertained.



*Figure 49: Motor Test Bench*

Table 15 below shows the test results for several different propeller designs. The first row in the table is the power draw for the motor with no propeller attached. The second row of the table is the power draw and resulting force using the impeller that came with the motor originally. This serves as a good baseline for the propeller design. We know that the motor is designed to run at 12 volts and 2.18 amps at its peak current draw. The motor is rated up to 4 amps, so there is some room to work with in the propeller design if we want to increase the force

we get out of the motors. Design #1 has 10 mm long fins with a pitch ranging from 30 degrees to 35 degrees. The width of the fin at the tip is 10 mm. Design #2 has the same length and pitch fins, but the width at the tip is 9 mm. Design #3 has a much larger fin size than the first two designs. The fins are 20 mm long and have a 50 degree pitch. Because of this, design #3 has a significantly higher current draw than the previous two designs. The power supply we used prevented the motor from drawing enough power to damage it. This dramatic drop in voltage and rise in amperage shows that this particular propeller design is too large to run with the motor. Based on the testing data Design #1 is the most viable option. Further design tweaks may happen before the final prototype is built. The 3D models for the three propeller designs are given below in *figure 50 - figure 52*.

*Table 15: Motor Testing Results*

Load	Voltage	Amperage	Force (lbs)
None	12.0	0.49	0.00
Stock Impeller	12.0	2.18	0.07
Design #1	12.0	2.04	0.57
Design #2	12.0	2.07	0.57
Design #3	9.2	3.10	0.53

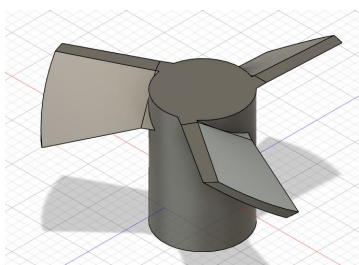

*Figure 50: Design 1*

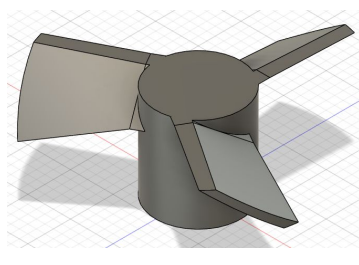

*Figure 51: Design 2*

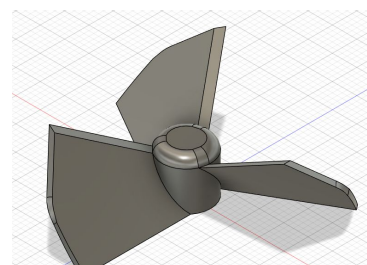

*Figure 52: Design 3*

## 6.1.9 Camera Testing

In order to test the potential camera layouts we designed a case for the Jetson Nano that holds the cameras in two different possible orientations. This case is shown below in *figure 53*. The first orientation has the cameras mounted side by side on the front of the case. This orientation allows for stereo vision applications. The second camera layout has a back to back camera bracket at the top of the case. This layout allows for full 3D image sensing. The bracket in *figure 54* was designed to hold the Jetson Nano in place while also allowing full access to the I/O ports, and the 40 GPIO pins. Special consideration was also used to ensure that the bracket doesn't come into contact with the heat sink located on top of the Jetson Nano.

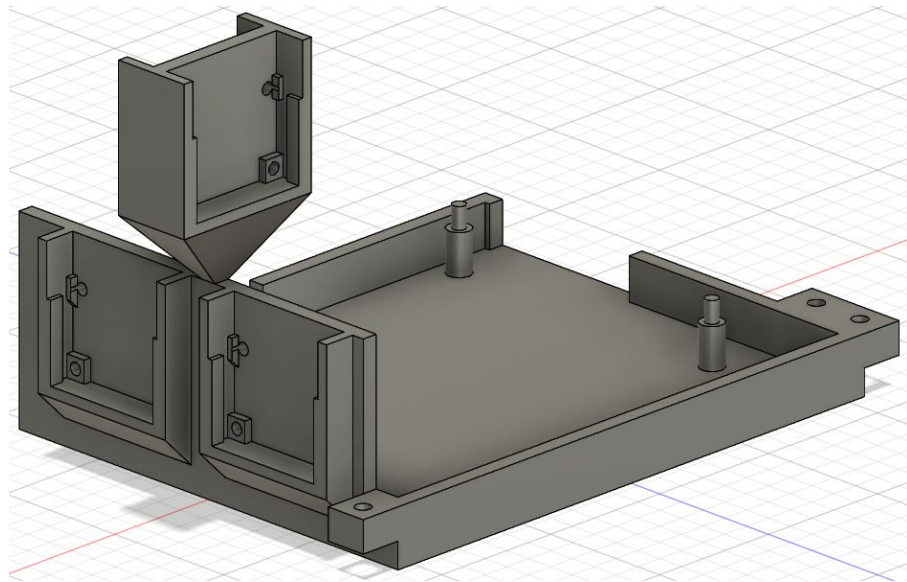

*Figure 53: Jetson Nano Camera Testing Case*

With options for mounting the cameras facing together in one direction, or facing opposite each other, this fixturing arrangement allowed for early explorations in stereo vision, and subsequent development of the omnidirectional video.



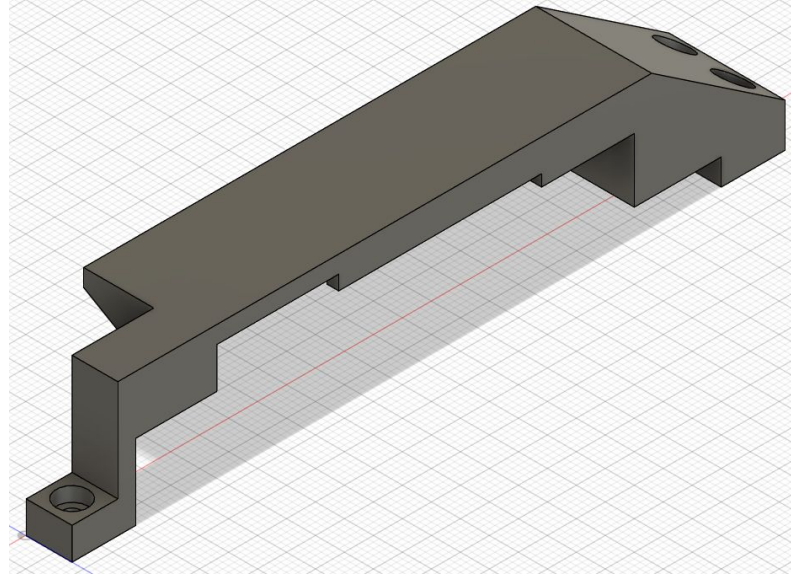

*Figure 54: Jetson Nano Testing Case Bracket*

The mounting of the cameras opposite each other aligns with the final goal of orientation, although in this case they are much closer together than the ultimate application. Below in *figure 55*, an equirectangular image has been captured with our system, and this image is viewable with common spherical photo browsing softwares.



*Figure 55: An omnidirectional, equirectangular image of a suburban yard.*

## **6.2 Prototype Testing**

When the individual components have passed testing the final prototype can be completely built. The final all encompassing design must be tested to ensure that the individual components all work together properly. The hardware testing section covers the mechanical aspects of this project. This includes how all of the wire feed throughs work, the battery consumption, the lights, and the connection between the surface and the ROV. The software testing section will include how all of the sensor data is fed through to the surface, ensuring that the bluetooth controller is able to feed a control signal all the way down to the motors, and that the video feed comes in clear.

### **6.2.1 Hardware Testing**

Throughout general testing of the system, periodic audits of the assembled device will be performed. These inspections will inform us of any slippage of mechanical joints and any leakage of water into the housing. Ballast adjustments will be made throughout testing in order to assure even flight underwater and that the ROV responds intuitively to input. Testing on the metal detector will be done to verify that the ROV itself doesn't interfere with metal detection. We must also be sure that the field generated by the metal detector does not interfere with any of the electronics in the ROV. Over the course of testing, ROS's feedback loops will be tuned to create a stable device that is able to manage its own yaw, pitch and roll.

### **6.2.2 Software Testing**

Software testing will be done to verify that the entire system is communicating with each other properly. The sensor information needs to be displayed correctly on the heads up display of the headset along with the fully processed camera feed. The IMU will need to be tested with the motors to see how well the ROV is able to stay in one place while in the water. The communication with the bluetooth controller will be tested to verify that all of the inputs from the controller to the ROV are working properly, and that the controller rumbles when the metal detector encounters a metallic object. The pressure reading from the pressure transducer will be converted to a depth reading and displayed on the headset. This depth reading will be validated using a pool with known depth markers.



The state of software components, and their passing or failing of required functions, is logged in the Git commit messages. This provides a means of identifying functional code in history that may break in future development iterations. This historic log of working code has proved invaluable as the iterative development cycle introduces new bugs to functional, tangentially related systems.

## **7.0 Conclusion**

Our entire project began with a motivation to make it easier to retrieve lost objects from the depths of Florida's waterways. This idea manifested into a remote operated vehicle with metal detecting features and the ability to locate and retrieve these valuables. Pre-existing products with these desired features come with the price tag of thousands of dollars, and are simply not affordable to the masses. That being said, our goal was set: to make a budget-friendly ROV with item-retrieving capabilities that can be used by those who are not as financially fortunate to afford such luxuries. Our team quickly got to work on ways to make our vision a reality. We began with researching existing products to enrich our knowledge of what's out there and how ROV's operate. We familiarized ourselves with motors, housing, powering, metal detecting, object retrieval, tethers, camera technology, sensors, lights, and all standard features that one would find on an ROV. We were able to then determine areas in which we could make certain costly features more affordable. The complex interconnected systems provide an opportunity to get hands on experience working with complicated embedded system design. We believe that we are in a good place to finish the build of the ROV, and complete all testing before the end of Senior Design II.

## 8.0 Appendix

### 8.1 References

- [1] "SPECIAL METAL DETECTOR ADDS CAPABILITY TO ROVS," *jwfishers.com*. [Online]. Available: <http://www.jwfishers.com/nr/nr259.html>. [Accessed: 02-Apr-2020].
- [2] "TWO-FUNCTION GRABBER ARM," *deeptrekker.com*. [Online]. Available: <https://www.deeptrekker.com/shop/products/two-function-grabber-arm>. [Accessed: 02-Apr-2020].
- [3] "Heavy Duty Large EZ Dig Metal Detector," *seriousdetecting.com*. [Online]. Available: <https://www.seriousdetecting.com/product/heavy-duty-large-ez-dig-sand-metal-detector-beach-finds-scoop-wet-dry-sand/>. [Accessed: 02-Apr-2020].
- [4] "Gladius Mini Underwater Drone," *chasing.com*. [Online]. Available: <https://www.chasing.com/gladius-mini.html>. [Accessed: 02-Apr-2020].
- [5] "BlueROV2," *BlueRobotics*. [Online]. Available: <https://bluerobotics.com/store/rov/bluerov2/>. [Accessed: 29-Mar-2020].
- [6] "Using ROVs In Diving Operations: What are the risks?," *FiskUSA*. [Online]. Available: <https://fiskusa.com/blog/rov/using-rovs-in-diving-operations-what-are-the-risks/>. [Accessed: 02-Apr-2020].
- [7] "Supported Frames," *ArduSub*. [Online]. Available: <https://www.ardusub.com/introduction/features.html>. [Accessed: 18-Mar-2020].
- [8] "T100 Thruster," *Blue Robotics*. [Online]. Available: <https://bluerobotics.com/store/thrusters/t100-t200-thrusters/t100-thruster/>. [Accessed: 14-Mar-2020].
- [9] "Smart Thruster," *Sea Drone Pro*. [Online]. Available: <https://seadronepro.com/accessories/thruster>. [Accessed: 14-Mar-2020].
- [10] "Explore the VS thruster," *Copenhagen Subsea A/S*. [Online]. Available: <https://www.copenhagensubsea.com/vs>. [Accessed: 14-Mar-2020].
- [11] "RC Boat Thruster 12-24V," *Amazon*. [Online]. Available: [https://www.amazon.com/Thruster-Underwater-Brushless-4-Blade-Propeller/dp/B07VWKPPJH/ref=sr\\_1\\_2?dchild=1&keywords=underwater+thruster&qid=1584647619&sr=8-2](https://www.amazon.com/Thruster-Underwater-Brushless-4-Blade-Propeller/dp/B07VWKPPJH/ref=sr_1_2?dchild=1&keywords=underwater+thruster&qid=1584647619&sr=8-2). [Accessed: 14-Mar-2020].
- [12] "hexTronik DT700 Brushless Outrunner," *Hobby King*. [Online]. Available: [https://hobbyking.com/en\\_us/hextronik-dt700-brushless-outrunner-700kv.html](https://hobbyking.com/en_us/hextronik-dt700-brushless-outrunner-700kv.html). [Accessed: 14-Mar-2020].
- [13] "ROV Thruster 10.5 Lbs From DT700 Brushless Motor," *Instructables*. [Online]. Available: <https://www.instructables.com/id/ROV-Thruster-105-Lbs-From-DT700-Brushless-Motor/>. [Accessed: 14-Mar-2020].
- [14] "Johnson Pump of America 28512 Marine Pump Cartridge for 1000 GPH Motor,"

- Amazon*. [Online]. Available:  
[https://www.amazon.com/Johnson-Pump-America-28512-Cartridge/dp/BooooBYOAV/ref=pd\\_bxgy\\_2/138-2874778-7413623?\\_encoding=UTF8&pd\\_rd\\_i=BooooBYOAV&pd\\_rd\\_r=273106f7-94be-451e-a29d-300d93aa05b4&pd\\_rd\\_w=iREcM&pd\\_rd\\_wg=xuxay&pf\\_rd\\_p=1b7ae7c4-8437-4495-a779-460fb30ae641&pf\\_rd\\_r=ZR43Z4PFB53AD4ANW1JD&psc=1&refRID=ZR43Z4PFB53AD4ANW1JD](https://www.amazon.com/Johnson-Pump-America-28512-Cartridge/dp/BooooBYOAV/ref=pd_bxgy_2/138-2874778-7413623?_encoding=UTF8&pd_rd_i=BooooBYOAV&pd_rd_r=273106f7-94be-451e-a29d-300d93aa05b4&pd_rd_w=iREcM&pd_rd_wg=xuxay&pf_rd_p=1b7ae7c4-8437-4495-a779-460fb30ae641&pf_rd_r=ZR43Z4PFB53AD4ANW1JD&psc=1&refRID=ZR43Z4PFB53AD4ANW1JD). [Accessed: 14-Mar-2020].
- [15] “DIY Submersible ROV,” *Instructables*. [Online]. Available:  
<https://www.instructables.com/id/DIY-Submersible-ROV/>. [Accessed: 14-Mar-2020].
- [16] “Adafruit 9-DOF Absolute Orientation IMU Fusion Breakout - BNO055,” *Adafruit Industries*. [Online]. Available: <https://www.adafruit.com/product/2472>. [Accessed: 19-Mar-2020].
- [17] “BerryIMU v2,” *Ozmaker*. [Online]. Available:  
<https://ozmaker.com/product/berryimu-accelerometer-gyroscope-magnetometer-barometricaltitude-sensor/>. [Accessed: 19-Mar-2020].
- [18] “SparkFun 9DoF Razor IMU Mo,” *SparkFun*. [Online]. Available:  
<https://www.sparkfun.com/products/14001>. [Accessed: 19-Mar-2020].
- [19] “Pulse induction vs beat frequency technology?,” *metaldetectorsa.co.za*. [Online]. Available:  
<https://metaldetectorsa.co.za/frequently-asked-questions/pulse-induction-vs-beat-frequency-technology/>. [Accessed: 02-Apr-2020].
- [20] D. Hernandez, “Become a Power over Ethernet (PoE) Expert in Just 5 Minutes,” *versatek.com*. [Online]. Available:  
<https://www.versatek.com/blog/become-a-power-over-ethernet-poe-expert-in-just-5-minutes/>. [Accessed: 02-Apr-2020].
- [21] “tp-link,” *tp-link.com*. [Online]. Available:  
<https://www.tp-link.com/us/business-networking/accessory/tl-poe150s/>. [Accessed: 20-Apr-2020].
- [22] “Fathom ROV Tether,” *Blue Robotics*. [Online]. Available:  
<https://bluerobotics.com/store/cables-connectors/cables/fathom-tether-nb-4p-26a-wg-r2/>. [Accessed: 19-Mar-2020].
- [23] “Stranded Wire vs Solid Wire,” *audiovideoelectric*. [Online]. Available:  
<https://www.audiovideoelectric.com/resources/stranded-wire-vs-solid-wire-which-is-best/>. [Accessed: 19-Mar-2020].
- [24] R. L. W. Robert D. Christ Sr., *The ROV Manual A User Guide for Remotely Operated Vehicles*. Elsevier Ltd., 2014.
- [25] “ROV 101,” *Ocean Innovations*. [Online]. Available:  
<https://ocean-innovations.net/companies/seabotix/training-and-education/rov-101/>. [Accessed: 09-Mar-2020].
- [26] “Bar30 High-Resolution 300m Depth/Pressure Sensor,” *Blue Robotics*. [Online]. Available: <https://bluerobotics.com/store/electronics/bar30-sensor-r1/>. [Accessed: 19-Mar-2020].
- [27] “It’s A Question Of Physics: What Is A Geiger Counter?,” *The Atomic Age*. [Online]. Available: <https://atomic.lindahall.org/what-is-a-geiger-counter.html>. [Accessed: 20-Mar-2020].
- [28] “Geiger Counter,” *MightyOhm*. [Online]. Available:  
<https://mightyohm.com/blog/products/geiger-counter/>. [Accessed: 02-Apr-2020].

- [29] “Cree XLamp XP-L High Density LED Star,” *ledsupply.com*. [Online]. Available: <https://www.ledsupply.com/leds/cree-xlamp-xp-l-high-density-led-star>. [Accessed: 20-Apr-2020].
- [30] “DUALSHOCK™ 4 wireless controller,” *PlayStation®4 User’s Guide*. [Online]. Available: [https://manuals.playstation.net/document/gb/ps4/basic/pn\\_controller.html](https://manuals.playstation.net/document/gb/ps4/basic/pn_controller.html). [Accessed: 19-Mar-2020].
- [31] “ALL-WET,” *seaconworldwide.com*. [Online]. Available: <http://seaconworldwide.com/products/electrical-wet-mate/all-wet/>. [Accessed: 20-Apr-2020].
- [32] “Sonar,” *Discovery of Found in the Sea*. [Online]. Available: <https://dosits.org/science/sounds-in-the-sea/how-do-people-and-animals-use-sound-in-the-sea/sonar/>. [Accessed: 19-Mar-2020].
- [33] “Raspberry Pi 4.” [Online]. Available: <https://www.raspberrypi.org/products/raspberry-pi-4-model-b/>. [Accessed: 03-Mar-2020].
- [34] “Jetson Nano,” *Autonomous Machines*. [Online]. Available: <https://www.nvidia.com/en-us/autonomous-machines/embedded-systems/jetson-nano/>. [Accessed: 10-Mar-2020].
- [35] “ROC-RK3328-CC (Renegade),” *Libre Computer*. [Online]. Available: <https://libre.computer/products/boards/roc-rk3328-cc/>. [Accessed: 15-Mar-2020].
- [36] “ASUS,” *Tinker Board*. [Online]. Available: <https://www.asus.com/us/Single-Board-Computer/Tinker-Board/>. [Accessed: 15-Mar-2020].
- [37] “UDOO BOLT.” [Online]. Available: <https://www.udoo.org/udoo-bolt/>. [Accessed: 14-Mar-2020].
- [38] “MSP430G2553,” *Texas Instruments*. [Online]. Available: <http://www.ti.com/product/MSP430G2553>. [Accessed: 13-Apr-2020].
- [39] “Atmega328P,” *Microchip*. [Online]. Available: <https://www.microchip.com/wwwproducts/en/ATmega328P>. [Accessed: 13-Apr-2020].
- [40] “ATSAMD51N19A,” *Microchip*. [Online]. Available: <https://www.microchip.com/wwwproducts/en/ATSAMD51N19A>. [Accessed: 19-Apr-2020].
- [41] “UCF Moving to Remote Instruction March 16,” *UCF Safety*, 03-Nov-2020. [Online]. Available: <https://www.ucf.edu/safety/ucf-moving-to-remote-instruction-march-16/>. [Accessed: 02-Apr-2020].
- [42] “Central Florida’s stay-at-home orders,” *WESH 2 News*, 26-Mar-2020. [Online]. Available: <https://www.wesh.com/article/orange-county-stay-at-home-order-frequently-asked-questions/31919891>. [Accessed: 02-Apr-2020].
- [43] “Florida governor issues statewide stay-at-home order,” *WESH 2 News*, 01-Apr-2020. [Online]. Available: <https://www.wesh.com/article/florida-stay-at-home-order-coronavirus/32008465#>. [Accessed: 02-Apr-2020].
- [44] G. Tremlett, “Treasure from sunken galleon must be returned to Spain,” *The Guardian*, 01-Feb-2012.

- [45] E. Au, "Bluetooth 5.0 and Beyond," *IEEE Veh. Technol. Mag.*, Jun. 2019.
- [46] J. Ozer, "What is H.264," *Streaming Media*. [Online]. Available: <https://www.streamingmedia.com/Articles/ReadArticle.aspx?ArticleID=74735>. [Accessed: 01-Apr-2020].
- [47] "H.264 Video Compression," *Haivision*. [Online]. Available: <https://www.haivision.com/resources/streaming-video-definitions/h-264/>. [Accessed: 01-Apr-2020].
- [48] "RoHS Guide," *RoHS*. [Online]. Available: <https://www.rohsguide.com/>. [Accessed: 21-Apr-2020].
- [49] "How CAT6 Cable Works," *Lifewire*. [Online]. Available: <https://www.lifewire.com/cat6-ethernet-cable-standard-817553>. [Accessed: 02-Apr-2020].
- [50] "Category 5, 5e, 6, 6a and 7 Cable Standards," *Cablek*. [Online]. Available: <http://www.cablek.com/technical-reference/cat-5---5e--6--6a---7--8-standards>. [Accessed: 02-Apr-2020].
- [51] "Cat6 Bulk Ethernet Cables," *Monoprice*. [Online]. Available: [https://www.monoprice.com/product?p\\_id=8103](https://www.monoprice.com/product?p_id=8103). [Accessed: 02-Apr-2020].
- [52] "Vertical Cable Cat6, UTP, Gel Filled (Flooded Core), Direct Burial, 1000ft, Black, Bulk Ethernet Cable," *Amazon*. [Online]. Available: <https://www.amazon.com/Vertical-Cable-Filled-Flooded-Ethernet/dp/B005AIP8Z4>. [Accessed: 02-Apr-2020].
- [53] "I2C-bus specification and user manual," *NXP Semiconductors*, 04-Apr-2014. [Online]. Available: <https://www.nxp.com/docs/en/user-guide/UM10204.pdf>. [Accessed: 02-Apr-2020].
- [54] J. Postel, "User Datagram Protocol," *Internet Engineering Task Force*, 28-Aug-1980. [Online]. Available: <https://tools.ietf.org/html/rfc768>. [Accessed: 01-Apr-2020].
- [55] "Fusion 360," *Autodesk Design Academy*, 2018. [Online]. Available: <https://academy.autodesk.com/getting-started-fusion-360>. [Accessed: 21-Mar-2020].
- [56] K. Townsend, "Adafruit BNO055 Absolute Orientation Sensor," *Adafruit*, 22-Apr-2015. [Online]. Available: <https://learn.adafruit.com/adafruit-bno055-absolute-orientation-sensor/overview>. [Accessed: 30-Mar-2020].
- [57] C. R. Spitzer, "Head-Up Displays," in *Digital Avionics Handbook*, Boca Raton, FL: CRC Press, 2001.

## 8.2 Permission

*Figure 1: JW Fishers RMD-1 attached to the SeaLion-2*



● Tyler Rose <tyler.rose5@yahoo.com>  
To: info@jwfishers.com

Sat, Apr 18 at 1:48 PM ★

Hello!

I am a student at the University of Central Florida, and I would like to use an image from your website in my report. I want to write about existing submersible ROVs and I would like to include one of your pictures in my report. Here is the url that contains the picture: [Special Metal Detector Adds Capability to ROVs](#)

**Special Metal Detector Adds Capability to ROVs**

JW Fishers manufactures underwater search equipment - side scan sonar, video cameras, remotely operated vehicle...



and this is the picture I would like to use in my report: [http://www.jwfishers.com/graphics/New\\_photos/RMD\\_main.png](http://www.jwfishers.com/graphics/New_photos/RMD_main.png)

Thank you for your time!



● JW Fishers Mfg <info@jwfishers.com>  
To: 'Tyler Rose'

Mon, Apr 20 at 1:38 PM ★

Good Afternoon,

Permission granted.

Please let us know if there is anything else that we can do for you and please forward us a copy of the report so we can read as we always enjoy these types of things.

Good luck,

Brian

Brian Smith-Fisher

Chief Operating Officer

**JW Fishers Mfg Inc.**

1953 County St.

East Taunton MA 02718

Tel: 508.822.7330

Fax: 508.880.8949

Web: [www.jwfishers.com](http://www.jwfishers.com)

Email: [Brrians@jwfishers.com](mailto:Brrians@jwfishers.com)



Figure 2: Deep Trekker Two-Function Grabber Arm

• Permission to use image 4

Yahoo/Sent ★



• **Tyler Rose** <tyler.rose5@yahoo.com>  
To: sales@deeptrekker.com



Sat, Apr 18 at 1:53 PM ★

Hello!

I am a student at the University of Central Florida, and I am doing my senior design project on submersible ROVs. I would like to use one of your pictures in my report about existing products. Here is the image I would like permission to use: [https://images.ctfassets.net/kzewhs8e6cvu/75PlkqOnAtviZFU5Heybl3/474937790b819b3e9bee11ebed2e0403/2\\_Function\\_Grabber\\_Arm.jpg?w=800&h=591&fit=fill](https://images.ctfassets.net/kzewhs8e6cvu/75PlkqOnAtviZFU5Heybl3/474937790b819b3e9bee11ebed2e0403/2_Function_Grabber_Arm.jpg?w=800&h=591&fit=fill) and here is the link to your website where I found it: <https://www.deeptrekker.com/shop/products/two-function-grabber-arm>

Thank you for your time!



• **Cody Warner** <codywarner@deeptrekker.com>  
To: Tyler Rose



Sat, Apr 18 at 3:09 PM ★

Hi Tyler,

You have permission to use the image

Cheers

Cody

> Show original message

Figure 4: Gladius Mini by Chasing Innovation

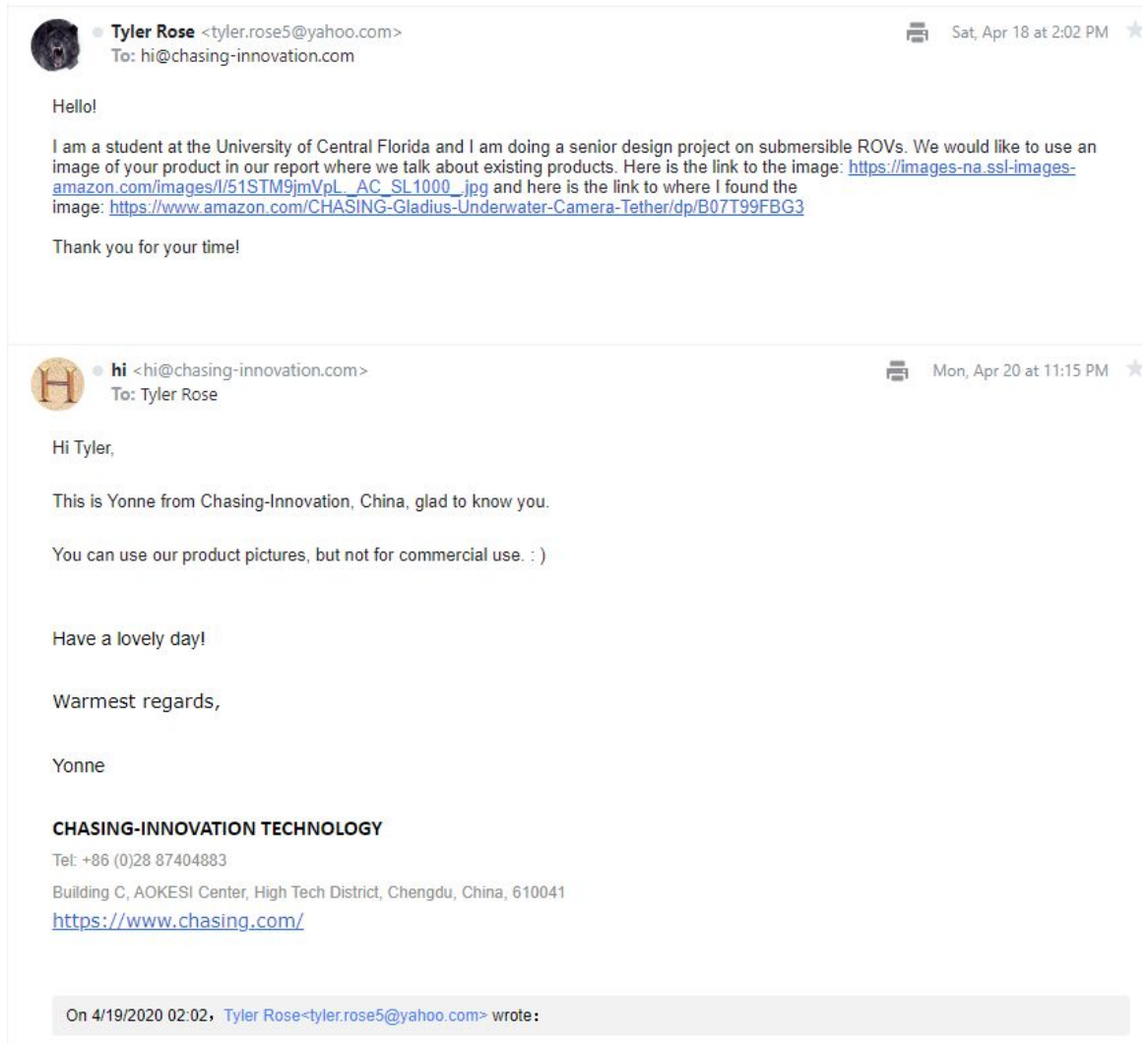



*Figure 9 - figure 14: Rov Motor Orientations*

## Overview

The information in this guide applies to ArduSub V3.5 and up. If you are running an older version, you should update.

## ArduSub and the ArduPilot Project

The ArduSub project is a fully-featured open-source solution for remotely operated underwater vehicles (ROVs) and autonomous underwater vehicles (AUVs). ArduSub is a part of the ArduPilot project, and was originally derived from the ArduCopter code. ArduSub has extensive capabilities out of the box including feedback stability control, depth and heading hold, and autonomous navigation.

ArduSub is designed to be safe, feature-rich, open-ended, and easy to use even for novice users.

ArduSub works seamlessly with Ground Control Station software that can monitor vehicle telemetry and perform powerful mission planning activities. It also benefits from other parts of the ArduPilot platform, including simulators, log analysis tools, and higher level APIs for vehicle management and control.

ArduSub is on the leading edge of marine robotics and intended for anyone who wants to operate a vehicle below the water's surface. There is support for many different ROV configurations, and adding a custom design is simple.

## About this Book

This book is an on-going work in progress to document the ArduSub software as well as supporting software and hardware. The documentation in this book is based on the most recent software available at the time of writing. In some cases, features or options documented here may be only available in developmental versions of the software. The authoring of this book and the ArduSub project are sponsored by Blue Robotics.

## License

- The ArduSub and ArduPilot code are released under the GPLv3 License.
- This book is released under the CC-NC-SA 4.0 License.

Figure 15: Thruster available on Amazon

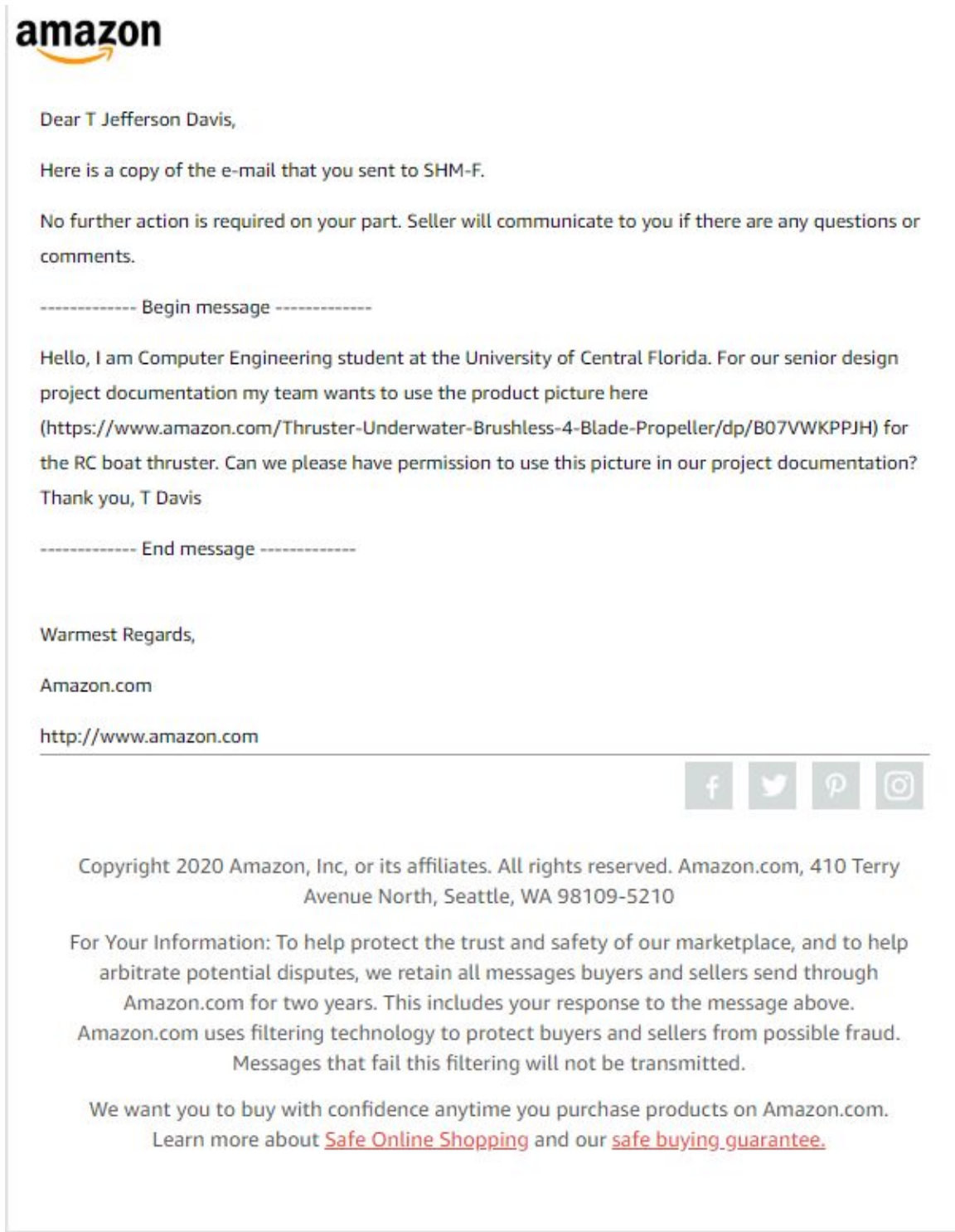

The image shows a screenshot of an email from Amazon. At the top left is the Amazon logo. The email body starts with a salutation 'Dear T Jefferson Davis,' followed by a message from Amazon stating that a copy of the sender's email to SHM-F is being provided. It then informs the sender that no further action is required and the seller will communicate if needed. A separator line indicates the start of the message. The message itself is a request from a student at the University of Central Florida for permission to use a product image from Amazon for a project. The product is identified as a 'Thruster-Underwater-Brushless-4-Blade-Propeller' with a specific Amazon product ID. The student thanks the recipient and signs off. Another separator line indicates the end of the message. Below the message, there are 'Warmest Regards,' the text 'Amazon.com', and a URL 'http://www.amazon.com'. A horizontal line separates this from a footer area containing social media icons for Facebook, Twitter, Pinterest, and Instagram. The footer text includes copyright information for Amazon, Inc. (2020), the company address in Seattle, WA, and a 'For Your Information' section explaining Amazon's policy on retaining messages for two years to protect the marketplace. It also mentions fraud filtering technology. The final part of the footer encourages buying with confidence and provides links to 'Safe Online Shopping' and the 'safe buying guarantee'.

**amazon**

Dear T Jefferson Davis,

Here is a copy of the e-mail that you sent to SHM-F.

No further action is required on your part. Seller will communicate to you if there are any questions or comments.

----- Begin message -----

Hello, I am Computer Engineering student at the University of Central Florida. For our senior design project documentation my team wants to use the product picture here (<https://www.amazon.com/Thruster-Underwater-Brushless-4-Blade-Propeller/dp/B07VWKPPJH>) for the RC boat thruster. Can we please have permission to use this picture in our project documentation? Thank you, T Davis





----- End message -----

Warmest Regards,

Amazon.com

<http://www.amazon.com>

---

Copyright 2020 Amazon, Inc, or its affiliates. All rights reserved. Amazon.com, 410 Terry Avenue North, Seattle, WA 98109-5210

For Your Information: To help protect the trust and safety of our marketplace, and to help arbitrate potential disputes, we retain all messages buyers and sellers send through Amazon.com for two years. This includes your response to the message above. Amazon.com uses filtering technology to protect buyers and sellers from possible fraud. Messages that fail this filtering will not be transmitted.

We want you to buy with confidence anytime you purchase products on Amazon.com. Learn more about [Safe Online Shopping](#) and our [safe buying guarantee](#).

Figure 23: Network switch and standards for PoE output

Image use permission 3 Yahoo/Sent ★

---

 **Tyler Rose** <tyler.rose5@yahoo.com> Sat, Apr 18 at 1:24 PM ★  
To: info@versatek.com

Hello!

I am a student at the University of Central Florida and I am writing a report for my senior design project. I would like to use a picture from your website in my report, and I am required by the university to obtain your permission. Here is the link to the page where the image is: [Become a Power over Ethernet \(PoE\) Expert | Versa Technology](http://www.versatek.com/versatek/wp-content/uploads/2015/01/poe-device-011.png).



**Become a Power over Ethernet (PoE) Expert | Versa Technology**

Learn how to determine the PoE power budget of your Power Sourcing Equipment (PSE) to determine if you're Powere...

And here is the specific image I would like permission to use in my report: <https://i0.wp.com/versatek.com/wp-content/uploads/2015/01/poe-device-011.png>

Thank you for your time!

← ↶ → ⋮

---

 **Shaw Tien** <shawt@versatek.com> Mon, Apr 20 at 11:33 AM ★  
To: Tyler Rose

Hi Tyler,

You may use it. It is a stock picture we used.



SHAW TIEN  
[shawt@versatek.com](mailto:shawt@versatek.com)

Versa Technology, Inc.  
Phone: 1-909-591-8891 x6 | Fax: 1-909-591-6962  
Websites: [Versatek.com](http://Versatek.com) | [Planetechusa.com](http://Planetechusa.com)

Websites: [Versatek.com](http://Versatek.com) | [Planetechusa.com](http://Planetechusa.com)

DISCLAIMER: This information is intended only for the use of the addressee(s) and may contain privileged, confidential or proprietary information. If you are not the intended recipient, or the employee or agent responsible for delivering the message to the intended recipient, you are hereby notified that any dissemination, distribution, displaying, copying, or use of this information is strictly prohibited. If you have received this communication in error, please notify us immediately at [info@versatek.com](mailto:info@versatek.com) or by telephone at (909) 591-8891, and return the information to the sender with all copies deleted and destroyed. Thank you.

> Show original message



image005.emz  
4.7kB

## Figure 26: Fathom ROV Tether



**Elisa Miller** <[elisa@bluerobotics.com](mailto:elisa@bluerobotics.com)>

12:47 PM



To: Sarah Reim Cc: [support@bluerobotics.com](mailto:support@bluerobotics.com)

Hi Sarah,

Thanks for reaching out! You are more than welcome to use the photos. Thanks for checking and good luck with your project!

Best,

**Elisa Miller**  
Blue Robotics  
[elisa@bluerobotics.com](mailto:elisa@bluerobotics.com)  
[bluerobotics](http://bluerobotics.com)  
--  
[www.bluerobotics.com](http://www.bluerobotics.com)

On Sun, Apr 19, 2020 at 10:22 AM Sarah Reim <[SReim1@knights.ucf.edu](mailto:SReim1@knights.ucf.edu)> wrote:

Greetings,

I am an electrical engineering student at UCF and our senior design team would like to use your picture of the fathom ROV tether in our document as example market products (pictures we want to use are attached). We're creating an ROV ourselves and found your tether as a very useful reference. We're hoping you'd kindly consider granting us permission to include these pictures in our document. If this is the wrong email to reach out to, I'd appreciate being directed to the right one.

Thanks so much,

Sarah Reim

*Figure 27: Steel wire strength member*



Sarah Reim <SReim1@Knights.ucf.edu>

4/19/2020 1:15 PM



To: sales@falmat.com

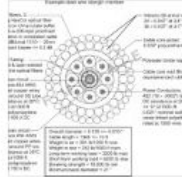

Greetings,

I'm part of a senior design team for UCF's electrical engineering program (BSEE) and my team would like to use your picture of an example steel strength member in our document (picture in question attached).

I'm sorry if sales is the wrong extension to reach out to and, if so, I'd really appreciate being sent to the right department where permission to use this picture can be granted.

We're working on an ROV for our senior design project and would be using your picture in our tether research.

Thanks,  
Sarah Reim