

# **Watt You Pay For**

Group 10

Spring/Summer 2018

Adam Althar

Charles Desowitz

Anders Hauge

Jonathan Killeen

# Table of Contents

1.0 Executive Summary .....	1
2.0 Project Description .....	3
2.1 Project Motivation .....	4
2.2 Goals and Objectives .....	4
2.3 Requirement Specifications.....	5
2.3.1 Software Functional Requirements .....	7
2.3.2 Hardware Functional Requirements.....	8
2.4 Marketing and Engineering Requirements .....	10
3.0 Research .....	12
3.1 Student Projects .....	12
3.1.1 Watt's the Matter .....	12
3.1.2 S.H.A.P.E.R. ....	13
3.2 Existing Products.....	15
3.2.1 TP-Link HS-200 Smart Switch .....	15
3.2.2 The Kill-A-Watt® PS-10 .....	17
3.2.3 Nest Learning Thermostat.....	18
3.3 Power Monitoring .....	20
3.3.1 Current Sensing .....	21
3.3.2 Voltage Sensing.....	23
3.4 Analog to Digital Conversion .....	24
3.4.1 ADC0804 .....	24
3.4.2 ATmega2560 Integrated ADC.....	25
3.5 Control Unit Data Transmission Methods.....	26
3.5.1 RS-485.....	26
3.5.2 Ethernet .....	26
3.5.3 Wi-Fi.....	27
3.6 Operating Systems.....	27
3.6.1 Ubuntu Server .....	28
3.6.2 FreeBSD .....	28
3.6.3 Windows Server 2016 .....	28
3.7 Power Transformation .....	29
3.7.1 Tamura 3FD-320 Power transformer .....	29
3.7.2 Würth Electronics Midcom 7508110151 SMPS .....	29

3.7.3 Capacitive Power Supply .....	30
3.8 Database Management Systems .....	31
3.8.1 MySQL .....	31
3.8.2 Redis.....	32
3.8.3 Maria DB .....	32
3.9 Microcontrollers .....	32
3.9.1 Texas Instruments MSP430F6638.....	33
3.9.2 Microchip ATmega5260 .....	34
3.9.3 Parallax P8X32A-D40 .....	35
3.10 Web Server Software .....	36
3.10.1 NodeJS .....	36
3.10.2 Apache HTTP .....	36
3.10.3 Nginx.....	37
3.11 Temperature Sensing.....	37
3.11.1 DS18B20 1-Wire Digital Thermometer.....	37
3.11.2 MCP9700A-E/TO Thermistor IC.....	38
3.11.3 LMT86-Q1 Analog Temperature Sensor .....	39
3.12 Displays.....	39
3.12.1 Crystalfontz CFAH1602B-TMI-JT.....	39
3.12.2 Adafruit 0.96" mini Color OLED .....	40
3.13 PCB Design Software.....	40
3.13.1 Altium .....	40
3.13.2 EAGLE CAD .....	41
3.13.3 KiCAD .....	41
3.14 Logic Level Shifter .....	41
3.14.1 Voltage Divider.....	42
3.14.2 TXB0108 8-Bit Bidirectional Voltage Translator .....	42
3.14.3 Bi-Directional Level Shifter .....	43
3.15 Operation Amplifier.....	43
3.15.1 OPA2180-Q1 Operational Amplifier .....	44
3.15.2 INA2128 Instrumentation Amplifier.....	45
3.15.3 INA828 Instrumentation Amplifier.....	45
3.16 Power Relay .....	45
3.16.1 RT1 Power PCB Mechanical Relay.....	46

3.16.2 G3NA Solid State Relay .....	47
4.0 Strategic Components and Part Selection .....	48
4.1 Current Sensor .....	48
4.2 Voltage Sensor .....	49
4.2.1 Final Voltage and Current Sensor .....	50
4.3 Analog to Digital Converter .....	50
4.3.1 Analog to Digital Converter Key Component.....	51
4.4 Microcontroller .....	52
4.5 Capacitive Power Supply .....	53
4.5.1 Key Power Supply Components Selection.....	53
4.5.2 Final Power Supply Selection .....	54
4.6 Digital Temperature Sensor .....	54
4.7 PCB Software .....	55
4.8 Display .....	56
4.9 Main Server Operating System .....	57
4.10 Main Server Web Server .....	57
4.11 Main Server Database.....	58
4.12 Control Unit Data Transmission Method.....	59
4.13 Discrete Logic Level Shifter.....	59
4.13.1 Key Discrete Logic Level Component Selection .....	60
4.14 Operational Amplifier.....	61
4.15 Power Relay .....	62
4.15.1 Final Power Relay.....	63
5.0 Related Standards.....	64
5.1 Wireless Communication Standards .....	64
5.2 AC Voltage Standards.....	65
5.3 Outlet Design Standards .....	65
5.4 Embedded C Coding Standard.....	66
5.5 Design Impact of Embedded C Coding Standard.....	67
5.6 Electrical Safety Standards .....	68
5.6.1 Live Parts Guarding .....	68
5.6.2 Conductor Identification Standards .....	69
5.6.3 Polarity Standards.....	69
5.6.4 Grounding Standards.....	70

5.7 UART Standards .....	70
6.0 Realistic Design Constraints.....	71
6.1 PUR and DSC .....	71
6.2 CU/MS Network Performance Constraints .....	73
6.3 Air-Conditioning Unit Constraints .....	73
6.4 Microcontroller Memory Constraints.....	73
6.5 Economic and Time Constraints.....	74
6.6 Environmental, Social and Political Constraints .....	76
6.7 Ethical, Health and Safety Constraints.....	77
6.8 Manufacturability and Sustainability Constraints .....	78
6.9 MySQL Database Standards.....	78
7.0 Project Hardware and Software Design Details.....	80
7.1 Control Unit Modules.....	80
7.2 NodeJS Server Modules .....	81
7.3 Connect/Setup Mode Logic Flow.....	82
7.4 Power Loss Recovery Program Flow .....	84
7.5 PUM Time Slot Method .....	85
7.6 Outlet Control Unit Prototype.....	87
7.6.1 Final Outlet Control Unit.....	88
7.7 System Connection Map .....	88
7.8 Main Server / Client Interaction .....	89
7.9 Microcontroller and Module Powering .....	90
7.10 Microcontroller Connections Overview .....	91
7.11 Time tracking on the Arduino.....	92
7.11.1 Final Time Tracking Implementation .....	93
7.12 Unique Thermostat Considerations .....	94
7.12.1 Final Thermostat Implementation.....	96
7.13 Microcontroller Power-Data Handling.....	97
7.13.1 Final Microcontroller Power-Data Implementation .....	100
7.14 MCU Relay Communication .....	100
7.14.1 Final Relay Implementation.....	101
7.15 Current Sensing Design Details .....	101
7.15.1 Current Sensing Second Stage Amplifier.....	103
7.15.2 Final Current Sensing Design Details .....	104

7.16 Voltage Sensing Design Details .....	105
7.16.1 Final Voltage Sensing Design Details .....	105
8.0 Roles and Responsibilities.....	107
9.0 Project Prototype Construction .....	108
9.1 Part Acquisition and Bill of Materials .....	108
9.2 Equipment and Facilities .....	109
9.3 LCD Temperature Prototyping.....	110
9.4 Setup Mode Prototype.....	111
9.5 Button Interaction Prototype.....	113
9.6 Relay Prototype.....	114
9.7 Minute counter Prototype .....	114
9.8 PCB Vendor and Assembly .....	115
9.8.1 PCB CART .....	116
9.8.2 Custom Circuit Boards <sup>TM</sup> .....	116
9.8.3 Gold Phoenix Printed Circuit Board Co. ....	116
9.8.4 Final PCB Vendor .....	117
9.9 Part Acquisition .....	117
10.0 Administrative Content.....	119
10.1 Budget.....	119
10.2 Milestones .....	120
11.0 Testing.....	122
11.1 Voltage Measurement Testing.....	122
11.2 Current Measurement Testing.....	123
11.3 Input Voltage ADC Testing.....	124
11.4 Input Current ADC Testing.....	125
11.5 Temperature Testing .....	125
11.6 Power Transformation Testing .....	126
11.7 LCD Testing .....	126
11.8 Module Stubs .....	126
11.9 Wi-Fi Communication Testing .....	127
11.10 MCU Timekeeping Testing.....	128
11.11 Facilities and Equipment .....	128
12.0 System Setup and Operation.....	130
13.0 Project Summary and Conclusion .....	132

14.0 Appendix.....	134
14.1 Resources .....	134
14.2 Copyright Permission .....	134

## List of Figures

Figure 1: House of quality.....	11
Figure 2: TP-Link HS-200 Courtesy of TP-Link .....	16
Figure 3: Kill A Watt® PS-10 Courtesy of P3 International .....	18
Figure 4: Nest Learning Thermostat Courtesy of Nest .....	19
Figure 5: Watt-Hour Meter Courtesy of Texas Instruments .....	33
Figure 6: Outlet Diagram .....	66
Figure 7: Control Unit Modules .....	81
Figure 8: Main Server Modules.....	82
Figure 9: Control Unit Setup/Connect Toggle .....	82
Figure 10: Control Unit Power On Flow Chart .....	83
Figure 11: Power Recovery Flowchart.....	85
Figure 12: Power Usage Measurement Method .....	86
Figure 13: Transmit Mode to Record Mode Transition .....	87
Figure 14: Outlet Control Unit Prototype.....	87
Figure 15: Setup Mode .....	88
Figure 16: Connect Mode .....	89
Figure 17: Main Server / Client Interaction Diagram.....	90
Figure 18: Microcontroller Powering Diagram.....	91
Figure 19: Microcontroller Connections .....	92
Figure 20: Minute Counter Flowchart .....	93
Figure 21: Thermometer Pun Configuration .....	95
Figure 22: A/C Control Unit Flowchart .....	96
Figure 23: Sample Rate Comparison Visualization .....	97
Figure 24: Power Data Handling Flowchart .....	99
Figure 25: Current ADC Pin Selection Flowchart.....	100
Figure 26: Relay Control Diagram .....	101
Figure 27: Shunt Current Sensing Circuit .....	102
Figure 28: Current Sensing Second Stage Amplifier Circuit .....	103
Figure 29: Final Current Sensing Schematic .....	104
Figure 30: Voltage Sensor Circuit.....	105
Figure 31: Final Voltage Sensor Schematic.....	106
Figure 32: LCD with Temperature Prototype. ....	110
Figure 33: Setup Mode Prototype.....	111
Figure 34: Control Unit Access Point.....	112
Figure 35: Wi-Fi Module Configuration Web Page .....	112
Figure 36: Wi-Fi Module Serial Feed .....	113
Figure 37: Button Input Prototype.....	113
Figure 38: Driver Prototype.....	114
Figure 39: Minute counter prototype output.....	115

Figure 40: Output Waveform of Voltage Sensor .....	122
Figure 41: Output Waveform at 15 amps through the Shunt .....	123
Figure 42: Output Waveform at 1 amp through the Shunt .....	124
Figure 43 Texas Instruments Innovation Lab Equipment .....	129
Figure 44: Control Unit Access Point.....	130
Figure 45: Control Unit Configuration Page.....	130
Figure 46: Main Server Login Page .....	131
Figure 47: Server Control Panel .....	131

## List of Tables

Table 1: Residential Power Use Breakdown .....	4
Table 2: Device Software Functional Requirements .....	7
Table 3: Database Functional Requirements.....	8
Table 4: System Specific Custom Requirements.....	9
Table 5: Standard Electrical Functional Requirements .....	10
Table 6: Current Sensor Comparison .....	49
Table 7: Voltage Sensing Comparison .....	50
Table 8: Analog to Digital Converters .....	51
Table 9: Microcontroller Comparison Table.....	52
Table 10: Power Transformation Comparisons .....	53
Table 11: Temperature Sensor Comparison.....	55
Table 12: PCB Software Comparison.....	56
Table 13: Display Comparison.....	57
Table 14: Operating System Comparison.....	57
Table 15: Web Server Comparison .....	58
Table 16: Database Management System Comparison .....	59
Table 17: Communication Method Comparison.....	59
Table 18: Level Shifter Comparison .....	60
Table 19: Operational Amplifier Comparison.....	62
Table 20: Power Relay Comparison .....	63
Table 21: EPUMF vs Data Storage .....	72
Table 22: Sample Rate Comparison Table.....	98
Table 23: Role and Responsibilities .....	107
Table 24: Bill of Materials of Key Components .....	108
Table 25: Bill of Materials of Accessory Components.....	109
Table 26: Facilities Used .....	109
Table 27: Vendors .....	118
Table 28: Expense Breakdown.....	119
Table 29: Completed Milestones .....	120
Table 30: In-Progress Milestones.....	121



# 1.0 Executive Summary

Power is something that affects nearly everyone in our modern-day society. As population growth increases and more people begin to use electricity energy demand will greatly increase. These increasing power demands have many negative effects on our society and environment. As the overall energy usage increases the amount of resources needed to create this power increases as well. This means that more energy sources such as coal and natural gas must be produced. These resources are currently the largest source of power generated and are nonrenewable. In addition, consuming these resources increases the environmental pollution and greenhouse gases. Having larger power consumption also has the effect of requiring increased infrastructure. As power consumption increases lines must be able to carry more and additional generation sources must be created. These additional infrastructures increase the cost of power for everyone and are very undesirable.

Because power consumption has become such an important topic in today's society it is our goal to give the individual the information to see their power usage and to give them the control over the power they can reduce to improve the environment and to save money. Because of this, the modules designed in this project were created with the idea of monitoring and giving users the option to reduce the power for devices that can easily controlled by the user. Certain devices such as the water heater, refrigerator and washer and dryer were not considered. This because the energy usage certain devices such as refrigerator, cannot be easily reduced by the user without replacing the device completely. Almost all people living in the modern world cannot simply turn the refrigerator off for a period of time without food spoiling or not washing the clothes without wearing dirty clothes. Because of this, our project focused on the monitoring of devices that the user can easily turn off and reduce their power usage without greatly reducing comfort. To accomplish this, our product will monitor three primary devices. The first module that will be a part of the energy measuring system is the smart outlet. This outlet will measure the energy usage of all devices that are currently plugged into it. This measured value will be transferred to an online website that can be viewed from desktop or cellphone. Additionally, the user will be able to switch off power to this outlet through a browser if something plugged into it, such as a television, was left on and is wasting energy. This the smart outlet will empower users to see their real time power usage of anything plugged in and make a decision to turn the plug off to save energy.

The second module is the thermostat. The thermostat is a device that users can easily control that has one of the largest impacts on home energy usage. When the air conditioner is on, the energy used by the unit will be measured and set to the server. The energy usage can be seen by the user and by seeing the amount of power used, will incentivize the user to turn on the unit less frequently.

The last module that users can easily control to reduce their energy usage is the light switch. The smart light switch implemented has a similar function to the smart outlet. Users will be able to see their past and present energy usage from the light switch the device is connected to. Additionally, if a light is left on by accident, the user will be able to turn off the light switch remotely through the website. The desire of this project is to give users the information of their everyday electric usage and to give them the power to reduce their energy by turning off devices that are accidentally left on either locally or remotely.

## 2.0 Project Description

In recent years the public has become more and more aware of the effect that power consumption can have. As awareness has increased, homeowners are looking for new and meaningful ways to both monitor and control their power consumption. Our Smart Home Energy Management System aimed to provide users with a complete system that will both give them control over their consumption in the form of remote on/off control and information in the form of power usage analytics.

Our system is composed of three major components and a web-based interface. The three devices are a smart light switch, smart outlet and A/C control unity. These devices will monitor the current consumption of the respective devices hooked up to them, then sending this data over the home's Wi-Fi network. The user will be able to control these devices and see their power consumption statistics via a web-based user interface.

The smart light switch is designed to fit a standard switch box. The device contains an MCU, Wi-Fi module, and the current sensing components. The power data will then be sent over the Wi-Fi network to the database will it will be processed. These components will require power even when the switch is in the 'off' position so it will be important that our switch box has a connection to the neutral wire. This will allow for a closed circuit even when the light switch is in the 'off' position, allowing the electronics to still be powered.

The outlet also uses standard housing which provides adequate housing for all the components. The outlet is also be composed of an MCU and Wi-Fi module and current sensing components. The power data is sent over Wi-Fi to the database. To power the electronics in the outlet we converted the signal from the standard 120V 60Hz to a signal that can the MCU and Wi-Fi module can be powered with.

The A/C control unit also contains an MCU and Wi-Fi module but not the current sensing components. However, unlike the other two components the A/C control unit also has an LCD screen attached to it to display the settings of the A/C unit, as is standard in practice.. In our interface we will show both the real power consumption of our model and a more realistic value to demonstrate a more accurate cost and power analysis.

Aside from the physical components we will also have a web interface that the user can use to control the devices when connected to the local network and provide information to them on their usage patterns, power consumption and cost. We will utilize a cloud-based computing server to process the data and the interface. This will prevent us from needing to create our own server and more accurately reflects how it is done in industry.

## 2.1 Project Motivation

Electrical energy has become a necessity for nearly all people in the world. With increasing human population and as non-renewable energies such as fossil fuels begin dwindling, power conservation has become increasingly more important. As our energy sources dwindle and greenhouse gas pollution becomes an increasingly bigger issue, saving energy will be one of the biggest problems in the 21st century. A large portion of our energy usage that people have a direct control over comes directly from household and residential users consuming power for their everyday needs. Giving people the ability to see their energy usage and give them the power to easily manage it was our motivation, with the effect of reducing electrical energy consumption by empowering users to see their real time power usage and the cost associated with it. Table 1 shows a breakdown of how electricity is used in U.S. Homes from the U.S. Energy Information Administration. This table shows why we choxd to tackle cooling/heating, lighting and outlets. These systems are the big spenders of energy in the home, so it is only logically that we would address the biggest spenders.

*Table 1: Residential Power Use Breakdown*

<b>End Use</b>	<b>Share of Total</b>
Space Cooling	15%
Water Heating	10%
Lighting	9%
Refrigeration	7%
Space Heating	6%
Televisions and Related Equipment	6%
Clothes Dryers	4%
Furnace Fans/Boiler Circulation Pumps	2%
Computers and Related Equipment	2%
Cooking	2%
Dishwashers	2%
Freezers	2%
Clothes Washers	1%
Other (Small electronic devices etc.)	34%

## 2.2 Goals and Objectives

The goal of this project was to create a smart energy management system for a household. This product allows for users to easily and quickly monitor their energy usage and directly convert their usage to real world cost. The system consists of three main components: a smart outlet, smart light switch and AC power monitoring system. For the smart outlet and light switch remote, switch

control was implemented. The power consumption of the lighting controlled by the switch, devices plugged into the outlet and AC unit was all displayed on a screen controlled by a microcontroller. This product educates users on their electricity habits and how their usage means from a financial standpoint. By having remote control over certain devices, this will empower users to have a greater control over their home energy usage. By giving users this power and control over their home they will not only save money but also promote good energy habits and draw attention to some wasteful practices they may not even be aware of. For example, without this system someone might not understand how leaving lights or the television on when they aren't using them could be potentially harmful. However, with this system the user will be able to directly see how that sort of behavior costs them money. The user will interact with the system through a web interface. This will allow us to provide the user with a robust interface where they can be given details about their particular energy usage in a number of formats. The user can also be able to remotely control the devices. Of course, the user can also be able to control the various devices in a more traditional manner.

## **2.3 Requirement Specifications**

The most important requirement for this project was the current sensing and voltage sensing module. Both are required to be measured because power has a real and reactive component. While reactive power is important for power quality, consumers only pay for the real power used. Measuring both the voltage and the current allows for the real power consumed to be measured by finding the phase difference between the two. Typically, it can be assumed that the voltage on a single-phase line for residential use in the United States of America is at 120 volts RMS. This voltage however is allowed to fluctuate within 5%. Measuring the actual voltage gave us the advantage of measuring more accurately by directly measuring any voltage fluctuation. In addition to a voltage measuring module, another requirement was that it has a current sensing module. Both the instantaneous voltage and current modules was then read by an Analog to Digital Converter. This device allowed the analog current measurement to be converted to a digital signal which can be interpreted by a computer. This data was stored temporarily in the MCU's memory. When enough data is accumulated, the energy usage over a specified time period will be transmitted to a base server over Wi-Fi. The Wi-Fi module will interact between the MCU that is built into the outlet and the server that will accumulate the data over a longer period of time. The MCU will also be able to receive signals from the base. The base will transmit data to tell the MCU when to turn on or off by the user or through updating the timer. The outlet and the light will have the ability to switch on or off through a high current, 15-amp relay. This relay will connect or disconnect the live wire to the outlet which will effectively turn it on or off. Controlling the relay through the MCU allows for the requirement to be remotely accessed much

easier. A signal sent through Wi-Fi will be able to access each individual module and be able to turn it on or off at the user's discretion.

The system shall be able to be controlled remotely from a web-based interface. Since the light switch, outlet, and AC unit must be able to be controlled remotely the device must be "always on". This is because even though power is not flowing to the light-bulb in the case of the switch, or the devices plugged into the outlet, the MCUs must still be have power to enable the remote control. As such it is important for MCUs to be put into a low-power mode when the devices are off, in order to not waste energy. Only components required for turning back on the devices, such as the Wi-Fi module and components involved in the interrupt routine will be left on. The MCU connected to the AC unit will act as the central hub of the system. The usage data from the outlet and switch will be transmitted to the AC unit's MCU. We will be utilizing the Arduino platform to perform these tasks. We have chosen Arduino as our platform due to the wide range of possibilities that can be performed using these devices, along with the massive catalog of information out there to help developers. We believe that using this platform will allow us to focus on implementing the functionality of our project and less time dealing with our platform failing us. The user will then be able to monitor and interact with the data from these devices and the devices themselves via an interface running on a rented Digital Ocean Droplet server. We are doing this, instead of creating our own server, since this is more realistic to what would be done in industry. It requires much less infrastructure for a company to simply rent a server than to create their own. We are going with Digital Ocean instead of some of the other alternatives due to our teams past experience with the service. In order to configure the devices each device will have its own Wi-Fi network. This is to allow for a more robust interface to be created instead of being limited by the MCU. It is also important for the device to be secure.

Each device in the system shall have a number of operational modes depending on what the user is trying to do at the time. This is true for each device, the outlet control unit, the light switch control unit and the air-conditioning control unit. The first mode the devices can be in is called 'Setup Mode'. In this mode the device shall not be monitoring power usage and will act as an access point for the user to connect to. While in setup mode each device shall setup and maintain its setup Wi-Fi network, with an ID and password. In this mode, each device shall also be used to serve the interface to the user's computer which allows them to configure the system. While in setup mode each device shall also handle inputs given by the user. to have a

The other mode of each device in the system is "Connect Mode". There are several desired behaviors that need to be explained for when a component is in this mode. Each of the individual devices shall be the initiator when establishing a connection with the main server. Each device shall also attempt to maintain the connection with the server. While in this mode each control unit shall attempt to establish and maintain a connection with the main server. In connect mode each

device also shall send power usage data to the main server. Likewise, each device shall receive control commands from the main server while in this mode.

There are also various behaviors of the webserver operates both by itself and in conjunction with the devices. First each unit shall have its specific settings sent to the server with the ability to track which device it is from. The web interface and the setup page for each unit shall be compatible with Firefox and Chrome. The main server shall serve the MS web interface, serve the login page to the user's browser clients and shall also relay commands from authenticated MS web interface clients to their respective control units. Likewise, the main server shall authenticate user login credentials sent from their web browser client. The main server shall display its respective user's register device data usage and provide the ability to control each device from the web interface. The web interface shall also notify the user if it is disconnected from the main server. The database shall also store the login credentials of

### 2.3.1 Software Functional Requirements

We had previously defined how the software components of our system shall operate, but it is also important that we defined the quantifiable requirements of the system. The table below defines these requirements for software side of our 3 major components of our system with the goal of providing demonstrable behavior of the system to provide a better understanding of how the final system operated.

*Table 2: Device Software Functional Requirements*

<b>Behavior</b>	<b>Value</b>	<b>Unit</b>
The outlet control unit shall connect to Wi-Fi in under	45	Sec
The A/C Control unit shall connect to Wi-Fi in under	45	Sec
The light switch control unit shall connect to Wi-Fi in under	45	Sec
At each location the voltage and current shall be sampled every	1	ms
The outlet control unit shall store power data of the previous	1	Min
The A/C control unit shall store power data of the previous	1	Min
The light switch control unit shall store power data of the previous	1	Min
The outlet control unit shall transmit power data to the database every	1	Min
The A/C control unit shall transmit power data to the database every	1	Min
The light switch control unit shall transmit power data to the database every	1	Min

Defining the functional requirements of the software for the 3 main components in our system is not sufficient, as this is only a portion of the software that comprises our system. We must also define the functional requirements for the server. The table below does this and should help to demonstrate what we will be working towards when we are designing our system.

*Table 3: Database Functional Requirements*

<b>Behavior</b>	<b>Value</b>	<b>Unit</b>
The main server shall authenticate in under	20	Sec
The main server shall allow passwords of up to	20	Char
The main server shall respond to device connection attempts in under	10	Sec
The database shall store outlet power data at a resolution of 1 minute for the previous	24	Hr
The database shall store A/C control unit power data a resolution of 1 minute for the previous	24	Hr
The database shall store light switch control unit data at a resolution of 1 minute for the previous	24	Hr
The database shall store outlet power data at a resolution of 24 hours for the previous	30	Days
The database shall store A/C control unit power data at a resolution of 24 hours for the previous	30	Days
The Database shall store light switch control unit power data at a resolution of 24 hours for the previous	30	Days
The database shall store outlet power data at a resolution of 30 days for the previous	365	Days
The database shall store A/C control unit power data at a resolution of 30 days for the previous	365	Days
The database shall store light switch power data at a resolution of 30 days for the previous	365	Days
Main sever shall send information to individual components in under	20	Seconds
The main server shall support simultaneous connections up to	50	CTNS

### **2.3.2 Hardware Functional Requirements**

Alongside the software requirements there were several quantifiable hardware requirements that needed to be explained. It was important to note that some of these requirements were defined by either us or as a requirement of the components in our system, while others were as requirements due to various electrical and building standards we needed to adhere to. The table below focuses on the functional requirements that were due to our system. These



include what voltage values we needed in order to power certain devices, and requirements of that nature.

*Table 4: System Specific Custom Requirements*

<b>Behavior</b>	<b>Value</b>	<b>Unit</b>
The outlet control unit shall withstand and measure current up to	15	A
The air conditioning control unit shall withstand and measure current up to	15	A
The light switch control unit shall withstand and measure current up to	15	A
The outlet control unit power supply shall be capable of providing a voltage at	5	V
The outlet control unit power supply shall provide at most	1	A
The air conditioning control unit power supply shall be capable of providing a voltage at	5	V
The air conditioning control unit power supply shall provide at most	1	A
The light switch control unit power supply shall provide be capable of providing a voltage at	5	V
The light switch control unit power supply shall provide at most	500	mA
The outlet control unit power supply shall be capable of providing a voltage at	3.3	V
The air conditioning control unit power supply shall be capable of providing a voltage at	3.3	V
The light switch control unit shall be capable of providing a voltage at	3.3	V
The outlet control unit shall have a minimum Wi-Fi range of	300	m
The A/C control unit shall have a minimum Wi-Fi range of	300	m
The light switch control unit shall have a minimum Wi-Fi range of	300	m

The requirement specifications that we defined are not enough to paint a complete picture of the requirements of our system. We must also address the functional requirements of our system that occur as a result of our environment. Since our system operates off of standard home power this introduces a number of functional requirements for our hardware. These Functional requirements are described in the table below.

Table 5: Standard Electrical Functional Requirements

Behavior	Value	Unit
The A/C control unit shall be capable of measuring power across power lines at	120	V
The A/C control unit shall be capable of measuring power across power lines at	60	Hz
The outlet control unit power supply shall be capable of measuring power across power lines at	120	V
The outlet control unit shall be capable of measuring power across power lines at	60	Hz
The light switch control unit shall be capable of measuring power across power lines at	120	V
The light switch control unit shall be capable of measuring power across power lines at	60	Hz

## 2.4 Marketing and Engineering Requirements

It was important to know the engineering requirements of the products as well as the desires of consumer. The house of quality provides an excellent visual model to demonstrate the relationship between these two aspects. The figure below shows the correlation between the customer requirements and the engineering technical requirements. These correlations are shown by up and down arrows. Single up or down arrows represent a weak correlation between the customer and engineering requirements. Tiles that are blank mean that there is no correlation between the two requirements. The double arrow represents a strong correlation between the two requirements. The house of quality also demonstrates the relationship between engineering requirements. The top pyramid shows if there is a positive or negative correlation between the engineering requirements.

		Technical Requirements					
		Sampling Rate	Communication Quality	Cost	Response Time	Security	
		+	+	-	-	+	
Customer Requirements	Measurement Accuracy	+	↑↑	↓↓			
	Power Consumption	-	↓	↓	↑	↓	
	Ease of Use	+		↑	↓	↑↑	
	Cost	-	↓↓	↓	↑↑	↓	
	Reliable	+		↑↑			↑
	Scalable	+	↓	↓	↓	↓	
Engineering Requirement Targets			1k Samples/ Second	100 foot signal radius	> \$200.00	> 10 seconds	SSL encryption

Figure 1: House of quality

## **3.0 Research**

Creating a well-made, well-designed project required having a good understanding of the various components and technologies that were being used in the project. In the following section we looked at previous projects, consumer level devices, potential components and technologies that we helped us in developing our project. The goal of this research was to provide us with a better understanding of the qualities we needed be looking for before we selected our specific devices, systems and designs. These qualities were then graded as objectively as possible as to give a clear and concise overview of the strengths and weaknesses of each specific component, and how they led us to selecting our final design.

### **3.1 Student Projects**

An important part of researching for our project was examining similar past senior projects. Investigating these projects helps to give us ideas on solutions to problems that we encountered, areas where other groups have failed so we could focus on those areas ahead of time, and opportunities for improving our project. When looking at consumer level devices they sometimes contain technologies that were either too expensive, complicated or otherwise unobtainable for use to utilize them in our project, however with other student projects we can get ideas for potential parts and design methodologies that are feasible at a senior design level. There were also certain aspects of our project we didn't consider, and this research helped to shed light on those issues.

#### **3.1.1 Watt's the Matter**

The first project that we investigated was 'Watt's the Matter: Home Power Management System'. This was the Senior Design project done by a group of students from UCF who took Senior Design I and Senior Design II during the Fall 2013/ Fall 2014 semesters. The students who created this project, defined their project as "An easy to use home power monitoring system enabling users to observe and control the power consumed at each outlet in addition to viewing the history of consumption over a predefined timespan." This project looks to tackle many of the same challenges as our group.

There are a couple immediate design differences between the "Watt's the Matter" project and our system. Their team decided to incorporate LCD display panels at each of the outlets as well as a central hub VGA Panel to control the connected devices. We opted for a web interface instead of the central hub. In a real-world

setting, the web-based solution we implemented has the advantage of massive cost savings by skipping the need to manufacture central hubs for each unit. It also provides an avenue for higher level programming to be used, instead of having strictly embedded software programming. This was a good opportunity for the two computer engineers on the team to develop a wider range of skills. The 'Watt's the Matter' project was also strictly designed for monitoring the power drawn at outlets. While this is certainly a good starting point, monitoring lighting and Air Conditioning helps to paint a more complete picture of the home power situation and give the users a more accurate idea of how they're using energy. As previously discussed, the U.S. Energy Information Administration published a breakdown of residential power consumption which found Space Cooling to be the highest power usage end use making up 15% of the power consumed in U.S. homes. Lighting came in at 3<sup>rd</sup>, being responsible for 9% of the total power used in the home.

On an electrical level the "Watt's the Matter" project appears to implement their power monitoring scheme in the same manner as we implemented. A low-ohm shunt resistor is placed in front of the load and the voltage across this shunt resistor is fed to the ADC of their MCU. The block diagram they use in their system was very beneficial to us in showing a possible way to step the signal down from the outlet to a signal that could be used to power our MCU. Their team accomplished this with a Capacitive Power Supply, a strategy previously unknown to our team. Our original plan was to utilize a transformer to step-down the signal. We investigated a capacitive power supply as well, but did not end up using this technique.

Selecting our wireless communication method was something our team was unsure of at first. From Bluetooth, to XBee to Wi-Fi there are many choices that appear to serve the same purpose. Examining this project helped us to work with one method over another. The "Watt's the Matter" team decided to go with XBee, and after examining their system this makes sense. Since they use a central control hub all they require is for inter-device connectivity. They don't need any sort of internet access, or interaction with devices they didn't create. Since we want to be able to interact with our devices via the web this pushes us towards Wi-Fi. Using Wi-Fi also enabled our system to have the potential to expand in scale, for example throughout an entire hotel or apartment building, as long as the devices are connected to the same local network. This is not true for XBee, which has some range limitations.

### **3.1.2 S.H.A.P.E.R.**

The next project that was investigated was the S.H.A.P.E.R. project, performed by a group of students from the University of Central Florida as a Senior Design project during the Fall 2015/Spring 2016 Semesters. They described their project as "A home automation system that is built to aid the user in having better power

consumption habits at an affordable price. The system will display power consumed using two smart outlets, automatic lighting and dimming capabilities and thermostat control.” The goals of this project again sound very similar to ours, including the thermostat control.

The S.H.A.P.E.R. project has a couple functional capabilities that are worth examining. A feature that our group had not considered is the incorporation of motion sensors for the light switches in order to automatically adjust the lighting to save power. Their system uses a mixture of motion sensors and temperature sensing to detect if someone is in a room. They also incorporate automatic A/C adjustment based on room occupancy. This idea is certainly one we considered heavily. If the goal of a system is to minimize power-consumption then the natural progression of this idea is automation. The use of heat-detection specifically, as it can possibly negate some of the drawbacks of motion sensing, like when people are sitting stationary at a desk for prolonged periods of time. The S.H.A.P.E.R. team also decided to utilize an Android based app to interact with their system. While we had considered the use of a mobile application, but upon inspecting they are also not having remote network connectivity, so it was more or less a preference-based decision. Since our team is more comfortable with web interface programming it made sense for us to use do so.

For the current sensing aspect, the S.H.A.P.E.R team also utilized a shunt resistor setup, but chose to go with an all-in-one current sense amplifier from TI. These ICs combine a shunt resistor and op-amp into a single IC that also performs the power calculations. While this is a very simple solution we wanted to have more control over how our data is being processed, meaning that a discrete op-amp/resistor combo was the more appropriate approach. Another sensing topic discussed was high-side versus low-side sensing. As was our initial thought, since our components will be measuring the power drawn through the outlet and light-switch, high-side sensing is what we defaulted to.

Seeing another group that had A/C monitoring as part of their system was also very insightful. They utilized a small LCD, only showing the information that would be shown on a typical A/C unit, such as current temperature setting an ON/OFF status. They also raise the point of making sure that the MCU used is capable of driving an LCD display and can receive inputs from I/O buttons in order to operate the A/C unit in a traditional manner.

The S.H.A.P.E.R. team also did inspection into different wireless communications, selecting from either Wi-Fi, Bluetooth, or Near Field Communication (NFC). They rather quickly reject the idea of using NFC as it suffers from range limitations and therefore isn't appropriate for this application. In the end this group chose to use Bluetooth instead of Wi-Fi due to Bluetooth having lower power consumption. For a system that is designed to help conserve power it is understandable to select the lowest power option, along with the team liking it for the simplicity of Bluetooth. However Bluetooth suffers heavily from range restriction, as well as being affected by physical interference. The S.H.A.P.E.R. team makes a strong case for using Wi-Fi including Wi-Fi's long

range, ability for multiple devices to be connected and high data transfer rate. The team was against using Wi-Fi due to its higher power consumption and requirement for a router to be present in order for the system to work. While the higher power consumption is certainly a problem, the range and interference limitations that Bluetooth suffers from simply make it not an option for our team. We felt comfortable that anyone who would be looking to implement these types of smart devices into their home would already have a local Wi-Fi network set-up and therefore the requirement of a router would not be a problem.

## **3.2 Existing Products**

It was difficult to find things such as block diagrams and schematics for consumer level devices since these things are often important intellectual properties of corporations that don't want to publish them online for others to copy. What was able to be gained from researching these devices was the features and methods used in creating a consumer level quality product. After conducting this research, we hoped to be able to create a system that behaved in such a manner that it could potentially be mass produced and sold in stores.

### **3.2.1 TP-Link HS-200 Smart Switch**

The TP-Link HS200 Smart Switch is single panel, Wi-Fi based smart switch from TP-Link. This switch provides has a number of interesting features that we could adopt in order to make our system more robust. One of the most interesting features is what TP-Link refers to as "Away Mode" This mode causes the light to turn on and off and random intervals to make it appear if someone is in the home even when it is unoccupied. As we had largely approached this project from a power conservation it was interesting to see other possibilities The switch also is capable of more standard features such as remote ON/OFF control and scheduling to allow the lights to turn on and off at user defined intervals. Figure 2 shows how simple the switch design is. There aren't any extra buttons save for a small latch at the bottom to cut all power to the device. The lack of extra features helps to make sure the whole device is able to fit in a standard light switch fitting.



*Figure 2: TP-Link HS-200 Courtesy of TP-Link*

Perhaps more of more interest than the switch itself is how TP-Link handles its wider smart device platform known as 'Kasa'. Kasa is a platform in the form of a mobile app that allows users to interact with the multiple smart TP-Link devices that may be in a user's home. On the Kasa application the user can monitor power usage similar to our system. There is a noticeable lack of user interaction with their energy statistics. The app tells the user the current power consumption of the device, the total consumption for the day, week and month along with their daily average over those periods of time. Since the goal of our project was more focused on power management it made sense for our system to attempt to provide more robust tools. This included things such as allowing the user to check power consumption over various intervals alongside allowing the user to choose which devices they see the data for. Also displaying graphs over energy usage over these same intervals helped the user know if they were potentially wasting energy at certain times of the day, or days of the week. Since we tracked and stored this data the only work this required was be creating a way for the user to interact with it. Also, with us using a web-based interface as opposed to an app, we had the liberty to incorporate features that require user interaction outside of what's possible on a touch-based device. The other thing to take away from Kasa is the modularity in the way the system is designed. New Kasa compatible devices have been released since the system has launched, which means the platform is designed in such a way to handle new hardware. This was certainly a goal to work towards for our system, and did in fact prove easier to create a platform that is a skeleton to which any number of devices could be added, than to approach it was a fixed structure that is only compatible with the three components we have planned.

Another major problem the examining the TP-Link HS200 help bring us towards a solution was that of device network configuration. We needed some way to easily connect the various components of our system to a new network. This



meant some way to communicate with each device without using the local network. Originally the idea of having either Ethernet or micro USB ports on each device in order to program them would be possible, but these options weren't practical. Doing this would require additional cost in the form of additional modules on each of our devices, not to mention the additional space this would require. It would also require us either shipping additional cables with our system or hoping our user has cables that aren't required for normal operation of our system. However, the way the TP-Link HS200 connects to the local network is having the user first connect to the device's own network. This presents the user with an interface where they enter in the login credentials for the network they wish to use the device on. This was a very clean way of allowing the user to configure without additional hardware costs, and ideally once this system is created for one of the devices it shouldn't be hard to port this system to each of the other devices.

### **3.2.2 The Kill-A-Watt® PS-10**

The Kill-A-Watt PS-10 is an energy monitoring power strip from P3 International. This device is in the form factor of a 10-outlet power strip, complete with an LCD display to inform the user about the power consumption of the outlet. This device has 10 outlets allowing for a plethora of devices to be connected. The device's operating range can also provide some target metrics for us, with an RMS voltage range of 108.0 to 132.0  $V_{RMS}$ , RMS current range of 0.0-150  $A_{RMS}$ , and Active power range of 0.0 to 1980 watts.

Seeing this device utilizing this form factor made us completely rethink our approach for the outlet component of our system. Originally, we were leaning towards a single outlet form factor, as is very popular. However, after seeing more devices like The Kill-A-Watt PS-10, we started to consider the advantages of creating a device more akin to a power strip than an individual outlet. The obvious one is the increased space for the various electronics such as the MCU to be stored. Rather than having a very limited amount of space where heat can easily become a major issue. Another major upside is the potential increased power savings. With a standard sized outlet device there is only statistics on one or two connected devices, but with a whole power strip the options are much greater. For example, the power consumption of an entire home entertainment center with Television, DVD player and other such devices being monitored, or an office setup where a desktop computer, multiple monitors and device chargers are being monitored and controller. Of course, this also would have provided us with unique challenges, such as grounding the multiple outlets and other unforeseen complications that would have arisen by the increased load.

From a feature standpoint, the Kill-A-Watt PS-10 provided us with insight into statistics to monitor that had not yet been considered. The Kill A Watt PS-10 displays the Max/Min Volts, Amps, Watts, PF & leakage current. While some of

these are potentially overkill for what a consumer may need to know, displaying leakage current did raise a good point. Duke Energy, and other energy companies often tell customers looking for ways to save energy to eliminate what is known as “Vampire Energy”, or the energy drawn by devices even when they are off. There are many devices that are common ‘energy vampires’ ranging from things like cell phone chargers, DVD Players and Televisions. Displaying vampire energy in our system could have empowered our user even further, making them more conscious of the potential ways they can save energy and money. While vampire energy is not a major spender of electricity, Duke Energy estimating a phone charger uses about 20 kWh or \$2.00 worth of electricity a year, since our goal was not only to give users power statistics but also help to make them more knowledgeable about how to save energy this information was still a very interesting consideration. One area the Kill-A-Watt PS-10 is different than our system is that it doesn’t have any sort of wireless network interaction or works as part of a larger system. It is standalone device, which explains the need for an LCD display on the power strip itself. Since our device interacted with our web interface we were able to forgo the LCD, instead focusing on wireless communication. Figure 3 shows a picture of the Kill-A-Watt PS-10 which does a good job of showing the LCD and multiple power outlets available on the power strip.



*Figure 3: Kill A Watt® PS-10 Courtesy of P3 International*

### **3.2.3 Nest Learning Thermostat**

Having now researched a smart light switch and a smart outlet, the final device we investigated was a smart A/C controller to have a reference for each component of our project. The device we investigated was the Nest Thermostat. The Nest Thermostat is a smart A/C controller that has become massively

popular in recent years. The Nest not only advertises giving the user more control over their home but also self-adapting to the user's lifestyle and automatically adjusting the temperature. We will examine what features they include in order to enable these capabilities.

The Nest Learning Thermostat prides itself on automatically adjusting to the user after about a week of use, with the goal of maximizing energy efficiency and user experience. To do this the thermostat records user adjustments in temperature in attempt to recognize a pattern, for example if the user consistently lowers the temperature before they go to bed, and raises it when they wake up the thermostat will instead automatically adjust the temperature at these times. The thermostat also uses phone GPS to tell when the user is out of the house and automatically switches to an 'eco' mode in order to save energy while the house is unoccupied. Then using the users GPS location the system will turn back on when the user is within a certain range of their house. This is a good way of dealing with a common issue in heating and cooling, which is people leaving their systems running even when they aren't present since they want the house to be at a comfortable temperature when they return, instead of waiting for the whole house to become heated or cooled upon their return. With the method nest uses, this should not be an issue. Unfortunately we did not chose to incorporate any sort of GPS features into our system as we only operated over the local network. However we did consider implementing user created scheduling to fix this problem for things such as when the user is going to or from work. In short, the nest is less about the device itself and more about the software behind it. Figure 4 helps to demonstrate this. The device doesn't show any information besides the current temperature, granted they use a beautiful display for this. The take away is creating a robust feature of power monitoring features for our system is more important than having a complex control unit for the A/C unit.



*Figure 4: Nest Learning Thermostat Courtesy of Nest*

Nest uses a mobile application to allow the user to remotely control their system, and takes some very creative approaches to help encourage users to save energy. While they provide standard feedback like how a user's energy consumption was spread out over a day, or differed from day to day the real interesting part is how they use gamification to get users excited about saving energy. One factor of this is what they refer to as "Nest Leaf Points" which are awarded to users who are changing their consumption to save more energy. This can be something such as having your cooling at a slightly higher temperature or heating at a slightly high temperature. Nest does this as they claim that "Setting the thermostat to save one degree can save up to 5% on your heating and cooling bill." These points are don't actually get used for anything but they are a good way of telling the user when they are being efficient and create that sense in a user that they are being rewarded for their efforts. Nest creates monthly energy reports telling users how many leafs they earned that month and their total for the year. The report also tells the user in what percentile they ranked in leaf earnings compared to other users in their state. The report also tells the user why their energy consumption may have changed from month to month, due to factors such as higher outside temperatures, being home less often or not adjusting the temperature as frequently. Perhaps the one place the Nest falls short is by not providing comparisons of the same month from the previous year. This can provide a more accurate picture of what is going on with a user's consumption habits since comparing a month that is fully in winter with one that is on the tail end of fall, such as November and December will obviously result in a change in heating and cooling usage. By allowing the user to compare their usage from this December to their usage from last December, they can see how they changed under similar conditions

### **3.3 Power Monitoring**

Power monitoring is a critical part of this project. The ability of being able to monitor how much power a device is using and how much using that device costs will help the user cut down on unnecessary power usage.

Power monitoring is broken into two parts, current sensing and voltage sensing. Apparent power is the sum of real power and reactive power. Real power is the power consumed by a resistive load, meaning that the current and the voltage are in phase. Reactive power is the borrowed power, meaning it absorbs and releases power. When there is reactive power present then the current and the voltage are out of phase. The consumer is only billed for the real power used. The RMS value of the current multiplied by the RMS value of the voltage is equal to the apparent power, however if the current wave form and the voltage waveform are multiplied together the power waveform is found. The average value of this power waveform is equal to the real power. This value is what the user will be billed for.

### **3.3.1 Current Sensing**

In order to accurately measure the real power that a device is using the current will be measured, however an analog to digital converter cannot read a current directly. Instead this current needs to be represented as a voltage that the analog to digital converter can read. The current in an outlet can range anywhere from 0 amps to 15 amps RMS, which is 22 amps peak. An analog to digital converter will only be able to read a voltage ranging from 0 volts to 5 volts, so this means that the negative 22 amp to positive 22 amp current will need to be represented as a 0 volt to 5 volt signal. In order to narrow down the choices for current sensing a couple of parameters were chosen, such as size, power dissipation, cost, accuracy, and ease of implementation. Size is a necessary parameter because the amount of room inside of the case was quite limited. It was also not desired to have a large amount of wasted power. Ease of implementation plays a big role into testing and creating multiple products. It was not desired to have a unit that is difficult to create or replicate. Finally accuracy was important because it was desired to achieve the most accurate estimate of real power use and total cost. Given these parameters the choices for a current sensor was narrowed down to three different devices, a shunt resistor, a current transformer, and a Hall Effect sensor.

#### **3.3.1.1 MSR3 5 Milliohm Shunt Resistor**

The MSR3 shunt resistor has a very low resistance of 5 milliohms and a power rating of 3 watts. The shunt resistor is placed in series with the load on the neutral side. Since the MSR3 shunt resistor is rated for 3 watts the shunt resistor will be able to operate at a current of up to 25 amps continuously, which exceeds the range of current from the outlet. The shunt resistor also has a low tolerance of 1%, meaning the value of the resistance will only change from 5 milliohms by 1%. Having a known resistance it is known that the current through the shunt, which is the same current that flows through the load, is equal to the voltage across the shunt divided by the resistance of the shunt. The relationship of the voltage to the current is linear due to Ohm's Law, so that means using a shunt resistor can be extremely accurate, but there are some issues that can cause inaccuracies. Firstly the voltage across the shunt resistor is ideally very small, which means that this value for the voltage will need to be amplified in order for the microcontroller to read the measurement accurately. Secondly, when a conductor heats up, the resistance of the conductor increases. This means that if the shunt heats up enough then the resistance may increase, which will lead to the equation to calculate current, voltage over resistance, to be nonlinear. That is why it is crucial for this implementation to use a shunt resistor that is designed for a much higher power rating than what will actually be the rated power. Another benefit of the shunt resistor is its size. Since the shunt resistor is simply just a

small piece of metal it will not take up much room. The only parts that will take up some room are the amplifiers. The shunt resistor would also only dissipate 1.125 watts of power at full load, meaning that if this shunt was at full load for 37 days it would only cost 12 cents. The final benefit of using the MSR3 shunt resistor would be that it is the most cost effective as it only cost at most \$1 per shunt resistor. One of the only negatives of using the shunt resistor is that it is not isolated from the MCU.

### **3.3.1.2 AC1015 Current Transformer**

A current transformer works in the same way as a voltage transformer, but instead up stepping up or stepping down voltage it steps up or steps down current. The output current is a function of the input current and the turn ratio. There are two type of current transformers, invasive and noninvasive. An invasive current transformer needs to be put in series with the load while the noninvasive current transformer only needs a line on the load to go through the core of the transformer. The AC1015 current transformer is a noninvasive current transformer. The AC1015 has a turn ratio of 1 to 1000, meaning that if 1 amp is flowing through the primary then 1 milliamp will be flowing through the secondary. It is capable of continuously running at 15 amps with a max primary current rating of 60 amps. A resistor will need to be placed across the secondary of the current transformer in order to translate the current to a voltage for the analog to digital converter. A resistor of the value 100 ohms is recommended and will produce a linear relationship of voltage and current for above 1 amp. It is very normal for the outlet current to be much less than 1 amp, which means that the accuracy of the AC1015 current will decrease as the current decreases. The AC1015 is also quite large at 24x24x11 mm. The price of the AC1015 ranges from \$4 to \$5. The AC1015 will only dissipate around 30 milliwatts at full load. The main benefit of using a current transformer is that the MCU side is completely isolated from mains voltage side.

### **3.3.1.3 ACS712 Hall Effect Sensor**

The ACS712 Hall effect sensor measures the magnetic field created off of the main line. The ACS712 would be placed in series with the load and is designed to handle currents up to 20 amps which exceeds the 15 amp maximum. The IC only needs to be powered by positive 5 volts. The output of the ACS712 is a voltage in the range of 0 to 5 volts and has a linear relationship to the input current. Since the ACS712 already outputs on a scale that the analog to digital converter can read there is no need of extra circuitry to level shift the zero centered sine wave produced from the shunt and current transformer. The ACS712 also isolates the MCU side from the mains side. The series resistance

of the IC is only 1.2 milliohm meaning only 270 milliwatts of power is being dissipated at full load. This IC is then more efficient than the shunt resistor but not as efficient as the current transformer. The cost of the ACS712 ranges from \$1 to \$2. The main drawbacks of the ACS712 are the accuracy and the rise time. The accuracy can be increased by increasing the value of a filter capacitor, but when this capacitor is increased the rise time increases. At best case accuracy the rise time will be above 1 millisecond. At worst case accuracy the rise time is 5 microseconds. This can cause quite large errors when calculating the real power of the device.

### **3.3.2 Voltage Sensing**

The other important aspect to power monitoring is accurately measuring the voltage. The voltage at an outlet is typically 120 volts RMS, however this voltage can vary from 110 volts RMS to 130 volts RMS. This range in voltage does not affect the power a device is using, but that still does not mean that when calculating the power used a value of 120 can be multiplied by the current being measured. The power that the consumer is paying for is the real power of the device, not the apparent power. The phase difference between the voltage and current affects the value of the real power. With this in mind it is now required to scale this 120 volt RMS, 170 volt peak wave to a scale from 0 volts to 5 volts. This can be done in two different ways. The first way is by using a voltage transformer, and the second way is by using a voltage divider. Both ways have their pros and cons and three parameters were used in order to choose a voltage sensor. Size, power dissipation, and accuracy were parameters used to narrow down the choices.

#### **3.3.2.1 Resistor Voltage Divider**

The analog to digital converter requires a voltage in the range of 0 volts to 5 volts. One simple and efficient way to convert 120 volts to 5 volts is by using a voltage divider. Using a 1 mega ohm resistor and a 32 kilo ohm resistor in parallel with the source will produce a voltage in the range of positive and negative 4 volts in between the two resistors. The amount of power that this process uses is very low at only 14 milliwatts. Another benefit of this design is the extremely low cost of only a couple of cents for resistors and the simplistic design and implementation. The only negative of using a voltage divider is that this method does not isolate the mains side from the MCU side.

### **3.3.2.2 Capacitive Voltage Divider**

Another method for voltage sensing is using a capacitive voltage divider. A capacitive voltage divider works in the same way as a resistive voltage divider except with capacitors in place of resistors. Since the impedance of a capacitor depends on the inverse of the capacitance times the frequency, having a low value capacitance will result in a high value impedance. The current flowing through a resistor is in phase, so the power of the device is purely real power. The current flowing through a capacitor is  $90^\circ$  out of phase of the voltage across it, so the power is purely reactive. Since reactive power is power consumed and released, the capacitive power supply does not actually use any power. The size of a capacitive voltage divider will not be an issue as a capacitive voltage divider will be around the same size as a resistive voltage divider. There also will not be any accuracy issues once the ratio of the impedances of the capacitors are found. Implementing a capacitive voltage divider would be fairly simple with the only complications being in initial tuning. The cost would be more than a resistive voltage divider but only because capacitors will cost a slight amount more than resistors.

## **3.4 Analog to Digital Conversion**

The analog to digital converter is the heart of any device that communicates with the real world. The analog to digital converter takes analog and often continuous signals and converts them into digital signals that can be read and processed by a computer. For the home energy monitoring system, two important analog signals need to be converted to the digital domain. The first signal that must be converted is the voltage sensing readings and the other important signal was the current sensing readings. Because both of these signals operate at 60Hz the same analog to digital converter can be used on each sensor. For devices that perform this operation, two options were examined. The first is an external ADC and the second is the microcontroller's built in converter. Each has its positives and negatives attributes which are examined in detail.

### **3.4.1 ADC0804**

The external analog to digital converter researched is the ADC0804 IC. This chip is an 8 bit analog to digital converter. This means that the voltage can be divided up to 256 times. Assuming our voltage input is 120 volts RMS, this gives a total voltage range of  $\pm 170$  volts or 340 volts peak to peak. Dividing the peak to peak voltage by the division range of 256 means that the smallest resolution this IC can achieve is 1.33 volts. While a higher resolution is desirable, this accuracy



would be acceptable to give a decently accurate voltage reading. The next important factor to consider when reviewing ADCs was the sampling rate. The ADC0804 has a conversion time of under 100 $\mu$ s which means it has the potential to sample at up to 10 kHz. Considering the voltage wave needing to be converted was only 60 Hz, the sampling speed at which this chip can perform is excellent and is far greater than what is necessary to measure the waveform. The ADC0804 has a voltage range of only 0-5 volts that it can convert. While this was a small range, large voltages can be scaled down through voltage dividers or transformers that can bring the voltage to a range that can be easily read. While it would have been more convenient to have a larger voltage range, it is not a big issue. An external ADC also has the benefit of reducing the burden on a CPU. On some microcontrollers, a built in ADC is included in the package. While this feature is very convenient, it can come at the cost of using many clock cycles to perform the conversion accurately. An external ADC would allow this conversion to be performed independently of the CPU and the digital data could be directly sent to the microcontroller. Lastly, the cost of adding an external ADC was considered. Depending on packaging, quantity, and location, the ADC0804 IC can cost anywhere between 2 - 6 dollars. While this is not a huge cost, the cost could of became a major expensive in large scale production, especially when the microcontroller may have the capability to do the analog to digital conversion for free.

### **3.4.2 ATmega2560 Integrated ADC**

The next option researched as a potential analog to digital converter is the Atmel ATmega2560. This microcontroller had the benefit of having a built in analog digital converter. The most obvious benefit to this is that if this controller is already used, its additional capability of doing conversion can also be exploited for free. Because of this, using the ATmega2560's built in analog to digital converter is an excellent choice for reducing cost. The built in ADC uses the internal clock divided to get a frequency range between 50 kHz to 200 kHz. At these frequencies the ATmega2560 is able to produce a 10 bit sample. This number of bits allows for an extremely fine resolution of 1024 steps. This equates to 0.33 volts when scaled to the full range of the peak to peak voltage in a household mains line. A resolution this fine can give an extremely accurate voltage and current readings. The microcontroller also has the advantage of going to even high frequencies up to 1 MHz at the cost of a lower resolution. The frequency range far exceeds the speed of the analog waveform and makes it an excellent choice for our project considering the wide range of resolution and various frequencies. One small negative is like the ADC0804, the Arduino's ADC can only handle input voltages from 0-5 volts. This means that the input voltage must be scaled down properly through a transformer or voltage divider for the converter to be able to read the range correctly.

## **3.5 Control Unit Data Transmission Methods**

A key decision during the design process was deciding on the means by which the control units would communicate with the main server. Choices were divided based on the medium they utilized and their reliance (or lack of) on a hub. The medium categories consisted of wireless and wired based data transmission methods. If a method required a hub to act as an intermediary (such as ZigBee) then it was categorized as hub-based. The features on which each data transmission method was evaluated are security, robustness, scalability, ease of use, range, and speed. Ease of use refers to the perceived implementation difficulty and the availability and quality of documentation for the given method. For legal concerns, data transmission methods which failed to meet a minimum level of security were omitted as possible choices. Methods which did not have a viable means of implementation and integration with the current system (i.e. those which did not have a prebuilt module which could be connected to a microcontroller) were also discarded. In order to effectively implement the live power consumption feed, we need a transmission method with a significantly high transmission speed. There are on average 40 outlets in a house in the US. We needed a transmission method capable of supporting 40 active devices at a time. Since the project involves connecting multiple nodes over long distances we wanted a transmission method with the farthest length possible.

### **3.5.1 RS-485**

RS-485 is a wired serial communication method designed to send data over long distances and in areas of high electromagnetic noise. It is used heavily in industry due to these two characteristics and supports full duplex operation. RS485 supports up to 32 devices and can transmit over distances of up to 1,200 meters. It uses a differential balanced line with twisted pair cabling. As it is a serial communication method, RS485 uses differential signals to transmit data via +/- voltage differentials of 5 volts. Data transmission rates for RS485 are capped at 100 kilobytes per second. One significant advantage of RS485 is that it is immune to noise. One disadvantage of RS485 is that its cables are much more expensive than other wired communication methods such as Ethernet. Cost for a RS485 Module such as the MAX485 RS-485 Module which meets the basic requirements average around \$7 per module.

### **3.5.2 Ethernet**

Ethernet is a wired communication method used in local areas networks. Cat 5 Ethernet cables can transmit up to distances of 100 meters long without

repeaters or hubs and run at speeds of up to 1000 megabits per second. The Ethernet method handles medium contention using carrier sense multiple access with collision detection. As it is a wired method, Ethernet is considerably more secure than wireless methods as it restricts medium access to devices that are physically connected. Ethernet also has a significantly higher bandwidth than wireless and has much less restrictive standards. This does not come without a trade of however. Ethernet is far less mobile than wireless communication methods and is vulnerable to cross talk with longer cable runs. Ethernet modules such as the ENC28J60 run around \$5.

### **3.5.3 Wi-Fi**

Wi-Fi is a wireless communication method which utilizes the 2.4 GHz and 5.8 GHz industrial, scientific and medical radio frequency bands. A significant disadvantage of Wi-Fi is that it is vulnerable to eavesdropping, ARP poisoning and de-authentication attacks. Devices using stock antennas can transmit up to 100 meters without the use of repeaters. Modern Wi-Fi uses carrier sense multiple access with collision avoidance to resolve medium contention. Another major issue with Wi-Fi is that it is significantly less reliable than wired communication methods. Deformation of packets can occur because of both collisions between simultaneously transmitting packets and by interference from external devices. Wi-Fi modules such as the ESP8266 cost around \$7.

## **3.6 Operating Systems**

Arguably the most critical component of the system is the main server operating system. The main server operating system would act as the foundation of the main server. It supports and acts as the intermediary between the database, web server and the physical network layer. Candidates were evaluated based on security features, hardware support, ease of use, and cost. Security was the most critical factor as the consequences of a breach in a system that controls AC mains power can be catastrophic. We selected operating systems which had support for popular security features such as port knocking, SSH keys, packet filtering and strong role-based access control. Linux based systems tend to provide driver support for a wide variety of hardware configurations while other operating systems such as Mac OS X server have more limited support. We wanted an operating system with good hardware compatibility so that server hardware would have minimal impact on the overall system functionality. Ease of use is dependent on both the documentation available for the operating system and the difficulty in working with it. To minimize risk, we wanted an operating system with a low learning curve and an intuitive interface. We also wanted an operating system which was cheap and had an unrestrictive license.

### **3.6.1 Ubuntu Server**

Ubuntu Server is an open source operating system. The operating system is one of many distributions of Linux and is based on the Debian architecture. Ubuntu provides both dynamic page file support and swapping partition support (however swapping partitions are not dynamic). One of the strongest advantages of Ubuntu server is security. Ubuntu server security features include a built-in packet filtering firewall, SSH key support, and role-based access control. Ubuntu server also has expansive driver support which allows it to be run on a wide variety of hardware configurations. Ubuntu Server has a modified general public license (GPL). The license does not require any monetary fees but it does require derivative works can only be distributed under the GPL licensing terms.

### **3.6.2 FreeBSD**

FreeBSD is an open source UNIX like operating system. FreeBSD comes with a robust set of security features including access control lists, mandatory access controls, security event auditing, and extended file system attributes. It also features remote SSH capability via its OpenSSH component. OpenSSH allows for encrypted data transmission over a network. FreeBSD maintains a Berkeley Software Distribution (BSD) license. BSD is less restrictive than copy left licenses like GPL as it does not require derivative works to maintain its terms.

### **3.6.3 Windows Server 2016**

Windows Server is a proprietary server operating system created by Microsoft which runs exclusively on x86 and 64 architectures. In terms of cost even a modest license comes with a high price. Included in the cost, however, is access to an effective technical support system. As it is a part of the Windows NT family, Windows server is more frequently targeted and thus is more vulnerable in terms of security. To cope with this Windows server offered a built-in antivirus known as windows and a firewall with security logging capabilities. One key disadvantage of Windows Server is its lack of stability. Changes in Windows Server configuration usually require a reboot to take effect. Frequent reboots in a time critical system such as ours would be unacceptable and would require a costly backup server to compensate for.

## **3.7 Power Transformation**

Most homes today have 120 or 240 volts RMS in their household outlet for daily use. While this power is useful in many applications, most devices which contain a digital logic circuit or IC cannot use such high voltages or alternating currents. The smart outlet, smart light switch, and smart thermostat all suffer from the issue of needing both high AC voltage for measurements and low DC voltage for microcontroller powering and operations. To solve this issue the high voltage power from the outlet must be effectively stepped down and rectified to voltages more useful to a computer. Many methods are explored to accomplish this goal which are invested in more depth below.

### **3.7.1 Tamura 3FD-320 Power transformer**

The power Transformer is one of the oldest and simplest ways to step up or down AC voltage through changing winding ratios within the transformer. The Tamura 3FD-320 has the benefit of being the simplest method of reducing the voltage. This transformer has two secondary windings. Connecting these windings in series results in an output voltage of 20 volts. While this voltage is significantly lower than the mains voltage, this reduction is still too far off to reasonably use for the microcontroller selected. The windings also can be used in parallel which means each winding has 10 volts RMS. This means the amplitude is 14 volts which is much more reasonable, but it would still require further reduction through a voltage regulator which adds complexity. Each winding can output 0.15 amps which gives a total power output of this transform is 3 VA which is decent and far exceeds the power needs of our project. The transformer size is quite large for a circuit component with dimensions of 1.22 x 1.4 x 1.26 inches. Because of this this transformer would not be able to fit in small packages and case design would have to be significantly larger to accommodate it. Additionally, power transformers are very expensive. Typical prices range from 5 –20 dollars depending on manufacturer, and quantities with the Tamura 3fd-320 costing 5.15 dollars per unit. Lastly, the safety of the power transformation was considered. Power transformers provide full galvanic isolation from the mains line on the secondary side. This means current from the secondary side cannot accidentally reach mains ground through a person's body.

### **3.7.2 Würth Electronics Midcom 7508110151 SMPS**

The Würth Switching Mode Power Supply (SMPS), is a transformer that is designed to operate at much higher frequencies than is typical of the power transformers. The Würth 7508110151 is designed to operate at 70 kHz which is

significantly faster than mains frequency and allows the transformer to operate much more efficiently. To support these high frequencies however, the circuit must have rectification of the mains voltage along with a high power high frequency transistor and a driving IC that can pulse the base of the transistor at high frequencies. The supporting circuitry that is required for switching mode power supplies adds a great deal of complexity and cost which is undesirable. Additionally, this high frequency switching can cause a great deal of RF noise throughout the household which will be present if not filtered out. Along with providing full isolation from mains, many of the ICs that drive the high frequency switching also support current measuring on the secondary side through the use of opto-isolators. This gives switching power supplies two-fold safety mechanisms. One is through protecting current flow to mains and through shutting down the switching circuit if the opto-isolators detect a short or overload on the secondary side. This makes switching mode power supplies the optimal choice when safety is of the highest concern. The Würth SMPS has a saturation current of 425mA. This gives this transformer a decent power output that greatly outperforms the power needs of the microcontroller's consumption. Lastly, SMPS are often smaller than traditional power a transformer which saves circuit space and cost. The Würth 7508110151 has a 0.55 x 0.55 x 0.5 inch dimension which is over 14 times less volume than Tamura power transformer. This would allow for much lower profile designs when making the smart outlet, light switch, and thermostat. The smaller size also correlates to a lower price with most switching power supplies costing between 3-10 dollars with the Würth costing 3.85 dollars.

### **3.7.3 Capacitive Power Supply**

The last method of power transformation researched was the capacitive power supply. This power supply has no particular manufacturer but rather describes a certain circuit configuration. This design uses a full bridge rectifier on the mains voltage with a current limiting capacitor. The rectified voltage then passed through another capacitor to make the output DC, along with a precision Schottky diode to keep the voltage constant. This design has many benefits as well as drawbacks. The biggest advantage of the capacitive power supply is that it is very cheap and simple to make. In this design there is no transformer, which is usually the most expensive component in power transformation. On top of this, not having a transformer greatly reduces the area of the PCB as well as reducing the profile of the board. Almost all components in the design can be implemented with cheap and small surface mount components with the exception of the large capacitors. The simplicity of the circuit also means it is easy to design and troubleshoot which greatly reduces the complexity of the overall design. The capacitive power supply has some limitations and drawbacks however. First, this design cannot be used for large loads that require a large amount of current. This however is not an issue for the project because nothing on the circuit board consumes a large amount of power. Secondly, this design does not have mains

isolation. This means failure or opening the device while being powered could result in being shocked from the mains power line. The capacitor that is directly connected to the mains voltage however does have a parasitic resistor that discharges the capacitor when unplugged which helps in safety however. Lastly it should be noted that the power factor of this device is extremely bad. The capacitive power supply typically has a power factor near 0. This is caused by the large capacitive load. While the extremely low power factor is a large issue for utility companies, it does not affect the customer in any way because the extra power consumed is refunded, resulting in a zero-net increase of real power consumed.

## **3.8 Database Management Systems**

A key part of this project was the selection of the database management system. We needed a system to store not only power usage consumption data, but user account data, and various log data. The primary features we focused on in our analysis of potential candidates was ease of use, security, scalability, speed, and cost. Ease of use is a qualitative metric refers to the perceived implementation difficulty and the availability and quality of documentation for the given method. In the context of DBMS security refers to the presence and effectiveness of security features to safeguard data from potential attackers. Performance was evaluated based on on-disk spatial overhead, scalability, data retrieval and storage speed. We also chose to evaluate only database management systems that were free and had permissive or no licensing constraints

### **3.8.1 MySQL**

MySQL is an open source relational database management system released under a modified GPL license. It is developed by the Oracle Corporation and it is free for private use. To run with the full SQL standard, it must be paired with a version of the InnoDB storage engine. MySQL is cross platform meaning that it can be run on multiple operating systems. As far as ease of use is concerned, MySQL has a large amount of well-written documentation available and an integrated development environment to level out the learning curve. A few key features MySQL offers includes triggers, stored procedures, and (most importantly) secure socket layer support. Having secure socket layer support in a system which handles sensitive information such as ours is invaluable. Access to stored procedure functionality is also useful as it allows the database to offload computational tasks from the web server software. Triggers also offload much of the logging associated with transactions between the WSS and the database. One major issue with MySQL is its lack of built in incremental backups. While most database management systems have this feature implemented and

enabled by default, MySQL requires that all tables be backed up explicitly. This increases the overall workload of the project as it requires more extensive testing between version changes.

### **3.8.2 Redis**

Redis is a cross platform, open source, in-memory key value store database management system. Redis essentially stores the entire data set in random access memory, using on-disk memory to periodically store snapshots. As its data set is stored on a volatile medium Redis can access data entities much more quickly than on-disk store systems like MySQL. As a result, Redis data sets are more vulnerable to crashing as data stored on memory that is not backed by a snapshot is lost. Another issue with Redis is its scalability. Redis only uses RAM to store data sets which could lead to significantly high server costs for large scale systems.

### **3.8.3 Maria DB**

Maria DB is a fork of the original MySQL database management system and is distributed over the standard GNU General Public Use license. It aims to both expand upon the functionality of MySQL and to surpass it in terms of performance. Maria DB has a significantly faster replication method, memory heap, checksum table. While Oracle is very strict about potential contributions to MySQL builds, Maria DB take advantage of community contributions allowing it to expand its functionality. Maria DB is also backwards compatible with MySQL.

## **3.9 Microcontrollers**

The microcontroller is the workhorse of our system. The device is responsible for receiving and storing data it is sent from the ADC, performing manipulation on this data, sending it to and controlling our chosen wireless communication device and just about everything else that needs to be done. Since each of our three components will use a microcontroller so it was important that we select one that has a wide range of compatible peripherals. There was also an extensive amount of programming that had to be done using these microcontrollers, so it was important that aspects such as available resources and user friendliness are considered. Specifically, for the A/C controller we needed to be able to drive a small LCD display and receive inputs from buttons for the A/C control unit portion of our system. Due to the importance of the MCU and the amount of time that



was to be spent working with the device it was important to carefully research all aspects of potential MCUs.

### 3.9.1 Texas Instruments MSP430F6638

The MSP430 is an incredibly popular family of microcontrollers from Texas Instruments. Texas instruments offers a line of development kits for their MSP430 family known as the “LaunchPad” line of products, designed to help familiarize customers with development using the device. This also means that there is an extensive amount of tutorials and design references both from Texas Instruments and other individuals that can be very helpful when working on our own project. T.I. even has multiple application notes on how to use the MSP430 in a Watt-Hour meter, similar to how we intend to use our MCU. The MSP430 family is also incredibly vast, so for the purpose of our research we focused in on the MSP430F6638.

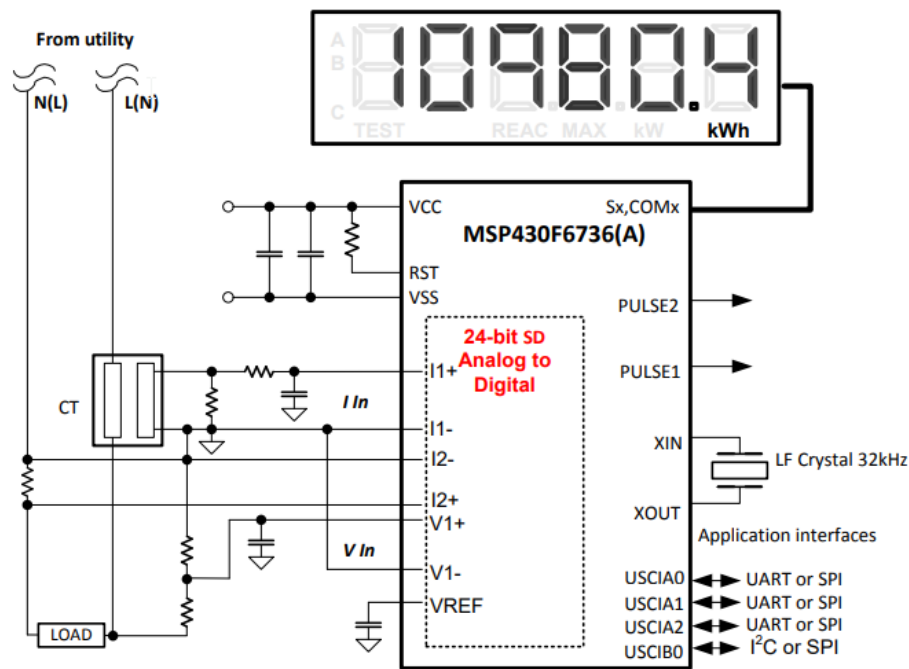

Figure 5: Watt-Hour Meter Courtesy of Texas Instruments

The MSP430F6639 offers 256 KB of Non-volatile Memory, 18KB of RAM that operates with a 16-bit RISC CPU and 16-bit registers, 11 of which are general-purpose registers with a speed rated at 16 MIPS. The device also has built in LCD drivers, which are a must in order for us to be able to drive an LCD display that will be part of our A/C control unit. These drivers support static, 2-mux, 3-mux and 4-mux displays. The MSP430 series instruction set consists of 51 instructions with three formats and seven address modes. As the MSP430 was the MCU used in the embedded systems course at UCF all team members

should have at least some familiarity working with this ISA. Another interesting feature of the MSP430 series is the variety of operating modes the device supports. There is a standard full power active mode along with seven different low power modes. Each low-power mode has a different combination of what devices are enabled or disabled, which clocks remain active or if data is retained. Since the goal of our project was to save energy, and the MCU will likely be the highest consumer of power in any of our devices, being able to effectively utilize these low-power modes could have potentially helped us to better achieve our goal.

Texas Instruments has also created their own IDE known as Code Composer Studio, which T.I. describes as “An integrated development environment (IDE) that supports TI’s Microcontroller and Embedded Processors portfolio.” Code Composer Studio has a number of features to help create and maintain projects such as a line by line debugger, ability to set flags to pause the program upon reaching certain lines of code and the ability to flash the code on to the MCU.

### **3.9.2 Microchip ATmega5260**

The next microcontroller we looked at was the ATmega2560 from Microchip. The ATmega2560 is very well known due to being the MCU of choice for the Arduino Mega, a wildly popular development board that is often used as an introduction to working with electronics and coding. What this means for us is there was a large amount of resources available to help less experienced users create their own projects and better understand the workings of the device.

From a specs standpoint, the ATmega2560 utilizes an 8-bit AVR RISC-based CPU, with 256KB of Flash Memory, 16MIPS CPU speed and 32 general purpose registers. The device also has 86 general purpose I/O pins so supporting the various components, specifically at the thermostat will certainly not be an issue for this device. The number of I/O pins is certainly overkill, but unfortunately the only package the device is offered in is a 100-lead package. Likewise it was better for us to have too many I/O pins and simply not connect them to anything than it was to end up with too few. The ATmega2560 was also more than capable of driving an LCD display, which is another requirement for the A/C control unit. The ATmega2560 also offers a variety of sleep modes which are designed to help save power by shutting down unused modules in the MCU.

To program the device, the self-titled Arduino IDE is a commonly used development environment. The Arduino IDE has offers the standard set of debugging features that one would expect out of an IDE designed for use with microcontrollers, but also offers a range of quality of life features such as auto-code formatting and customizable font sizes amongst others. One of the other great features of the IDE is the built in “Examples” library. These are small pieces of example code that can range from things like outputting something to a display to transmitting via a Wi-Fi module. This comfortable IDE along with the wide

range of resources makes the job of the person writing software for the MCU easier.

### **3.9.3 Parallax P8X32A-D40**

The final potential microcontroller option that we investigated was the P8X32A-D40 from Parallax. Similar to the previous two options we had first considered, there is an educational platform from Parallax known as “Propeller” that incorporates a spin of the P8X32A, designed to help get those unfamiliar with working with an MCU up to speed. However this platform is seemingly the least popular of the three, resulting in a less-substantial library of tutorials and guides to reference while designing a system such as ours.

Where the P8X32A-D40 does stand out is the impressive technical specs of the device. The MCU is built around a 32-bit 8-core CPU allowing for various parallel processing strategies to be implemented. These 8-cores combine for a total processing speed of 160MIPS, or 20MIPS per core. The device also has a whopping 32 I/O pins, which is possibly excessive for our needs, but would be give us wiggle room in the event that an unforeseen device need to occupy pins in order for our system to get up and running. To support the variety of possible I/O configurations the P8X32A-D40 has a set of pre-built objects for video sources such as VGA as well as support for LCDs in the form of 256 stored character definitions for programming an LCD which can prove helpful in the event that the on-board library of the LCD in the system is lacking. Unfortunately while the P8X32A-D40 has the ability to switch between two clock modes to operate at low-power there isn't the robust offerings seen in the MSP430 or ATmega2560.

From a programming standpoint, the P8X32A-D40 uses the PropellerIDE. Alongside the traditional features, the PropellerIDE also features a highly customizable UI alongside a memory-map feature which can help programmers understand how their data is being processed by the MCU. This can be very helpful when doing certain debugging tasks. However what is the most unique feature of the PropellerIDE in combination with the P8X32A-D40 is the support of the proprietary “Spin” language, alongside the modified C and assembly languages that are more standard offerings for MCU programming. Spin is an Object-Oriented language, unlike C and assembly. This was interesting as it is often easier to create more complex programs using object-oriented languages while being much more straightforward to understand than C code for the same task.

## **3.10 Web Server Software**

The primary purpose of the web server software in this system is to serve the interface to users. Features on which each possible choice was evaluated include security, ease of use, and performance. As the web server software acts as the front end of the main server it will bear the brunt of cyber-attacks and must be capable of effectively dealing with such attacks. The server also needs to be capable of handling a large volume of concurrent requests at a time. Ease of use in the context of web server software is a qualitative metric that refers to the perceived implementation difficulty and the availability and quality of documentation for the given method.

### **3.10.1 NodeJS**

NodeJS is an open source, cross-platform server framework. One of the major features which sets NodeJS apart from other web server software is its built-in asynchronous I/O support. As a result, NodeJS web servers can handle multiple requests concurrently. Another key feature of NodeJS is that server-side code is written in JavaScript. This helps eliminate traditional web server development boundaries as both the front-end and the back-end code is (in part) written in the same language. NodeJS is not without its flaws, however. As it is a relatively young framework, it does not yet support multi-threading in the traditional sense. As a result, NodeJS does not perform as well when handling a high number of concurrent connections. Due to its complexity, support for multi-threading is unlikely to be introduced for some time. Another issue with the age of NodeJS is that it is constantly undergoing API changes. These constant changes are usually backwards incompatible, meaning that code must be rewritten to accommodate such changes.

### **3.10.2 Apache HTTP**

Apache HTTP is an open source, cross-platform server framework. The framework has a long development history and is actively maintained. Due to its long history, Apache HTTP has a great deal of documentation available. Three important characteristics which Apache HTTP is known for are its reliability, flexibility, and high performance. Apache HTTP is flexible in part due to its use of `htaccess` files. These files provide a means to restrict file access by web clients on a per-directory basis. In other words, sensitive system files which lie in the web directory can be "hidden" from users. Apache HTTP also provides load balancing support which can help redirect high request volumes among multiple servers. To increase performance, Apache HTTP provides a selection of Multi-

Processing Modules. The most significant feature of Apache HTTP is its security. As a majority of exploits are written for Microsoft systems there are far less known Apache HTTP exploits.

### **3.10.3 Nginx**

Nginx is an open source, cross platform, web server software. The software is distributed under the standard 2-clause BSD license. It was written with the goal of surpassing the Apache web server and sports a variety of features including load balancing, Transport Layer Security, IP address based virtual servers and reverse proxy. In terms of memory and performance usage Nginx outperforms both Apache and NodeJS. In addition, Nginx web servers can handle more simultaneous clients with less processes than other servers like Apache. In terms of ease of use, Nginx web servers are much more complex to setup and modify. Module creation, in particular, is a daunting task as Nginx does not as of yet provide an intuitive interface for effective installing and swapping out modules.

## **3.11 Temperature Sensing**

Temperature is an incredibly important parameter in our society. Temperature affects many facets of our lives such as cooking something to the right temperature, ensuring a component does not get too hot, or keeping our day to day lives comfortable. In the home energy monitoring project, temperature sensing is one of the most vital components to the home thermostat. The temperature sensor tells the microcontroller when the thermostat needs to turn on or off the air conditioning. Because of this, was important to choose a sensor that can accurately and effectively measure the temperature and relay the information so that the user can remain comfortable and can accurately tell what temperature he or she desires to keep the household. There many different methods of temperature sensing that were researched below to discover the best method for the thermostat.

### **3.11.1 DS18B20 1-Wire Digital Thermometer**

The DS18B20 is a small, three pin thermometer that typically comes in a TO-92 package. This device uses one pin for the data communication and two pins for the powering. The DS18B20 has a very flexible internal EEPROM that allows for many different user configurations. One of the configurations is selecting the resolution of the sample. The digital thermometer is able to sample the current temperature and convert it to a digital signal that is between 9 to 12 bits.

Selecting more bits will consume more data but will give much more accurate temperature reading. The DS18B20 has temperature range from  $-67$  to  $257$  degrees Fahrenheit. This temperature far exceeds the temperature range of the average home user and gives an excellent range for any temperature any household may be. The accuracy of the DS18B20 is also quite good with the error of the thermometer is roughly 1 degree at most temperatures. This accuracy however does decrease if the number of bits is reduced from twelve bits. This device also has temperature safety alarms. The DS18B20 has user settable temperature limits which are triggered when the temperature exceeds the set temperature. When this occurs, the device sends out an alarm signal which on the data pin which then can be read from a microcontroller and take related action. The powering of the DS18B20 is also quite flexible. The  $V_{DD}$  pin can be powered from  $3 - 5.5$  volts. Additionally, the  $V_{DD}$  pin can be unused entirely if space or powering is an issue. The chip is able to run in parasitic mode where it is completely powered through the data line. This however requires the line to always have a pull up resistor. Additionally, the DS18B20 requires a strong pull up resistor when analog to digital conversion occurs and the data bus cannot be pulled low during this time. This device requires also has the benefit of needing no external components to be fully implemented which greatly increases the ease of use. The table below gives an overview of the qualities of the DS18B20. Lastly the price of the temperature sensor is neither expensive nor inexpensive. Prices of this device range between 2-4 dollars depending on quantity and location of purchase.

### **3.11.2 MCP9700A-E/TO Thermistor IC**

The MCP9700A-E is a low cost three pin analog thermistor. This thermistor acts as a cheap but somewhat inaccurate thermometer. This device can operate at a large range of input voltages from  $2.3-5.5$  volts which makes powering the device very easy. Because this device is analog, the signals that come from the  $V_{OUT}$  pin are an analog voltage. This means that not only does this device need an analog to digital converter, but it also requires a voltage to temperature conversion table to change the digital voltage reading to an actual temperature that can be used. These two reasons increase the complexity of implementing the MCP9700A by a large margin. The MCP9700A does have a very large temperature range. This device can operate from  $-55$  to  $130$  degrees Celsius. This range is far larger than the temperature of any temperature that a normal household would reach and far exceeds the needs of the project. The cost of this device is also extremely low. Packages of this device are as low as 32 cents which makes it an extremely cost-effective device for low cost devices. The major drawback to this device of this device is the accuracy of its measurements. The MCP9700A has an error of up to 4 degrees Celsius which equates to 7.2 degrees Fahrenheit. This is a large amount of temperature variance which would be acceptable in some applications but is completely unusable for a home

thermostat system. Overall, this device has some good qualities but was overwhelmingly overshadowed by its flaws for this application. The table below reviews these qualities.

### **3.11.3 LMT86-Q1 Analog Temperature Sensor**

The LMT86-Q1 is surface mount three pin temperature sensor manufactured by Texas Instruments. This device has an excellent input voltage range of 2.2 - 5 volts which gives it a large powering flexibility. This device also has a linear voltage output dependent on the temperature. Because of this, the LMT86-Q1 also requires an analog to digital converter and a conversion table. These elements cause the complexity to increase by adding the use of a converter and increasing the coding required to get a measurement. Like many temperature ICs, the LMT86-Q1 has a very large temperature operating range. This device can run from -40 to 150 degrees Celsius. The wide temperature range greatly exceeds the temperature requirements for typical household ranges. The cost of the LMT86-Q1 is decently priced at 95 cents per component. This device has a typical accuracy of 0.4 degrees Celsius but can go to a maximum of 2.7 degrees. The typical error range is acceptable but the possibility of it going very far out of range makes it an unideal choice. This device has many positive and negative qualities that are reviewed in the table below.

## **3.12 Displays**

Almost all A/C control units have a small display to tell the user basic information about the system. Generally this consists of if the A/C unit is turned on, what the current temperature of the house and what temperature the user has set the device to. In order to display this information, a Liquid Crystal Display, or LCD is often used. For our project it was important that we found a display that is easy to use, has low power consumption and is large enough to display the information we needed to display. It was also important to be aware of how the display handles data transmission with the MCU, as there is only a finite number of I/O pins for us to work with.

### **3.12.1 Crystalfontz CFAH1602B-TMI-JT**

The first display we chose to research was the Crystalfontz CFAH1602B-TMI-JT. This device is a simple 16x2 LCD that operates at 5V with a typical supply current of 1.2 mA. The device interfaces with the microcontroller using either 4-bit or 8-bit parallel communication. An important part of this display is that it is supported by the Sitronix ST7066U controller which is important as it eliminates

the need for us to program a font library. What made this display special when compared to other displays is the backlighting. Many other LCD displays are very hard to read under certain lighting conditions, but the white on blue color scheme along with the use of backlighting made this display easily readable at either day or night. The size of the display does limit the information we can display to only the essential information of current temperature and set temperature, along with the potential of an ON/OFF icon.

### **3.12.2 Adafruit 0.96” mini Color OLED**

The other display we had considered was a mini color OLED from Adafruit. This device consists of a 96x64 RGB pixel display driven by a SSD1331 chip. This display allows for a wide range of colors thanks to the 16-bit color resolution for each pixel. This device also communicates via 4 pin SPI connection. The device requires a 3.3V power supply. Adafruit supplies an open source graphics library for drawing pixels, lines, shapes and other symbols along with a coding and wiring tutorial. This would have allowed us to display more information on the screen, though the small size can make it somewhat hard to read despite the high contrast offered by the OLED.

## **3.13 PCB Design Software**

PCB design is a very important part of any modern circuit design. There are many different types of software to facilitate this designing process. PCB design software helps implement layout, trace routing, and component placement. Each software has its strengths and weaknesses which were looked into further detail.

### **3.13.1 Altium**

Altium is an industry orientated software that can make PBC designs and an eCAD program that can create 3D models of the board and components placed on it. This software also has no limits on the amount of layers, pins or signal layers on the PCB design. This makes it one of the most flexible designing software available. The software is also very intuitive to learn which means it will save a large amount of time learning how to design in it. Unfortunately, this software also cost the most out of any PCB design software with licenses costing over 7000 dollars and no free student version. While this software would be useful to learn because it so common in industry, the price made it unfeasible for the scope of this project.



### **3.13.2 EAGLE CAD**

Eagle CAD is another PCB design software that is used by both hobbyists and engineering companies. Eagle has many features depending on which version is used. Fortunately, Eagle supports both a student and a full professional version. The professional version costs 100 dollars per year which is very affordable and the student version is completely free. The free student version does have some limits that may hinder designs however. The educational edition has 99 schematic sheets available which should be plenty for the scope of the project. Additionally, the amount of layers is greatly limited, with only six layers allowed. Lastly, the routing area of the PBC design is limited with only 160x100 mm allowed. Eagle has varying learning curves depending on the user however. Some users state that the learning process is very easy while others have stated it requires a great deal of time to use efficiently.

### **3.13.3 KiCAD**

KiCAD is a free PCB Design CAD program. This program also works on Linux, Windows, and OSX. This software is primarily focused towards hobbyists as it has not been widely adopted in the industry. Even though it is not used professionally very often, KICAD still has a wide variety useful features that can assist in circuit design and layout on a PCB. KiCAD has a PBC Layout that assists in routing and supports up to 32 layers which is greatly exceeds the amount of layers most likely needed in this project. Additionally, much like Altium, KiCAD supports a 3D viewer to see dimensions and components placed on the board. KiCAD has a useful schematic capture that gives an easy to view overview of the circuit and the components. KiCAD also automates a bill of materials on the schematic capture which will quickly and easily allow for final component selection. Lastly, many people have had positive experiences with learning how to operate the software. Many modern reviews suggest that learning the basics of KiCAD does not take a large amount of time.

## **3.14 Logic Level Shifter**

There are many devices today that are required to operate on their own specific voltage. If these voltages are too high, the component may fail due to overvoltage. If the voltage is too low, the chip may not power on or the signal sent to the device may not be read. These issues can make it extremely difficult to communicate between two devices that have different operating voltages. In the scope of the power monitoring system, the issue came with the microcontroller which runs on 5 volts and the Wi-Fi module that requires only 3.3

volts to operate. This means direct communication between the two devices was not possible because the microcontroller will send a logic high voltage of 5 volts which could damage the Wi-Fi module. Because of this, the voltages in which the logic one and logic zero are transmitted were needed to be converted before they reach the corresponding module. The following research looks into methods of this conversion.

### **3.14.1 Voltage Divider**

The Voltage Divider is one of the simplest ways to step down the voltage. By selecting correctly sized resistors, the output voltage can be very easily stepped down from 5 volts to 3.3 volts. Additionally, this method is the cheapest to implement because the cost only comes from two extremely cheap resistors and a tiny amount of additional board space. The simplicity and low cost comes at a price however. The voltage divider is extremely inflexible. Because it steps down the voltage through resistors, any current that is pulled from the divider drops the voltage below the expected voltage. This means that anything connected to it has to be high impedance for it to output the correct voltage. Additionally, it also means that the voltage divider cannot be used to power any device. Lastly, the voltage divider is only able to step down voltages and cannot be used to increase the logic voltage level. This means that the microcontroller must be able to read input voltages lower than 3.3 volts as logic high or bidirectional communication is impossible. Because our microcontroller needs to send and receive data from the Wi-Fi module, this makes it a poor choice to shift the logic levels.

### **3.14.2 TXB0108 8-Bit Bidirectional Voltage Translator**

The TXB0108 is an 8-bit level shifting IC that comes in various surface mount packages. The TXB0108 allows for bidirectional communication with two different communication voltage levels. This device allows the  $V_{CCB}$  input voltage to range from 1.65 volts to up to 5.5 volts. The low voltage side,  $V_{CCA}$  allows an input voltage from 1.2 volts up to 3.6 volts. These voltages neatly fit into the projects needed ranges of 5 volts for the microcontroller and 3.3 volts for the Wi-Fi module. Additionally, the TXB0108 has an output enable feature that can allow the input of the signal to go to high impedance. This allows unwanted noise or signals to not be communicated when starting up or when communication is desired to end. Additionally, the TXB0108 requires no supporting components other than capacitors on the input voltages for voltage stability and noise reduction. This device also has electric static discharge protection with port A able to handle up to 2000 volts and port B up to 15kV. This protection adds to the robustness of the device and makes it more reliable in the long run. Lastly, the

cost of this device is relatively inexpensive with the cost of one IC ranging between 2 dollars to 80 cents depending on vendor and quantity purchased.

### **3.14.3 Bi-Directional Level Shifter**

The Bi-Directional level shifter is a simple device that uses discrete surface mount components to achieve voltage level shifting from both sides. This device allows for 5 volts to be shifted down to 3.3 volts and to let the low voltage logic level of 3.3 volts to be shifted up to 5 volts. This device, while not complex, allows for the dual communication between the microcontroller and the Wi-Fi module selected in this project. The simplicity of the device also gives it a huge advantage. This device only uses three components per pin. The two resistors and one MOSFET transistor are surface mount and costs mere cents to purchase. On top of this, the design allows for extremely easy scaling. Because this design does not use integrated circuits, the amount of level shifters can be arbitrary and can easily be scaled to be as many or as few level shifters as needed. This allows for much more efficient usage of shifters than an integrated circuit package would provide because it is very unlikely that the package will have exactly the same amount of that you need to shift without having too many or needing to have an additional IC. The only downside to this is that having individual discrete components adds a significant amount of labor soldering than a single IC package would need.

### **3.15 Operation Amplifier**

The current through the shunt resistor is proportional to the voltage across the shunt resistor and its resistance. The resistance of the shunt is desired to be very low, to decrease the wasted power, which will result in the voltage across the shunt also being very small. This small voltage needs to be read by the analog to digital converter so that the microcontroller can process the data. The analog to digital converter has an accuracy of about 5 mV, but when a current of 1 amp DC is flowing through the shunt the voltage across the shunt is only 5 mV. With this small voltage, the analog to the digital converter will not be able to accurately read the voltage waveform, which is why an amplifier is necessary. Using an operation amplifier for the amplifying process is desired due to a number of reasons. The single packaged operational amplifier IC can be very simple to implement as there are only 5 pins on the chip. Two of these pins act as the input, two pins are for powering the device, and one pin is for the output. The operational amplifier is also simple to implement because the value of the gain can be determined by the value of one or two resistors. The operational amplifier also has an extremely high internal gain, meaning that it is possible to amplify a very small signal into a much more readable signal. Another benefit of the

operational amplifier is that the device has extremely high input impedance. This means that essentially no current flows into the input pins of the operational amplifier. This is beneficial because the system that this operational amplifier will be connected to will see currents of up to 15 amps. Because of the extremely high input impedance, the input current will be close to zero, even when dealing with currents up to 15 amps.

The operational amplifier does however have one issue that will need to be dealt with, and that is the common mode rejection ratio. The common mode rejection ratio is the ratio at which the operational amplifier can sense a difference between the two inputs. This means that if a very small difference voltage is sent into the operational amplifier, it may not see any voltage at all, so no matter how high the gain of the amplifier is there still may not be any output. This will be an issue when attempting to amplify the very small voltage that will be across the shunt resistor. A specific device that does have a high common mode rejection ratio is an instrumentation amplifier. An instrumentation amplifier is an operation amplifier configuration in a single integrated circuit that is able to read in extremely small voltages. Because of this both operational amplifiers and instrumentation amplifiers are looked at and compared. Some key factors that are looked at in order to choose the best solution are cost, common mode rejection ratio, minimum supply voltage, and input impedance.

In total three operational amplifiers was required, one for the voltage waveform and two for the shunt resistor. The operational amplifier for the voltage waveform will be primarily for protection, as the gain of this amplifier will only be one. When the operational amplifier is powered by a set voltage the output of the amplifier will never go above that powering voltage. This will protect the MCU in case of over voltage going to the operational amplifier. The two operational amplifiers for the shunt resistor will be necessary because a two stage amplifier will be implemented. Because three operational amplifiers in total will be necessary there is a choice on what to get. Since only a single instrumentational amplifier is needed it is possible to get only one and then two operational amplifiers. Because of this both single channel and two channel chips are looked at. In the next section three different devices was looked at, the two channel OPA2180-Q1 operational amplifier, the two channel INA2128 instrumentation amplifier, and the single channel INA828 instrumentation amplifier.

### **3.15.1 OPA2180-Q1 Operational Amplifier**

The OPA2180-Q1 is a high precision two channel operational amplifier. The OPA2180 has many benefits for being two single operational amplifiers, such as a low price. The price of a single chip will be less than \$3, which is much less than a high precision instrumentation amplifier. Next the OPA2180 has an excellent common mode rejection ratio for only being a single operational amplifier. The common mode rejection ratio ranges from 104 dB to 114 dB, which

is quite high. For a reference a standard operational amplifier such as the TL08x only has a common mode rejection ratio of around 86 dB. The next parameter to look at is the minimum supply voltage. The OPA2180 has a minimum supply voltage of 4 volts, or +/- 2 volts, and the maximum supply voltage is 36 volts or +/- 18 volts. This meets the needs of the system as the operational amplifier is not be powered by anything less than 5 volts. The final aspect of the OPA2180 that was looked at is the input impedance. The input impedance of the OPA2180 is very large at 100 M $\Omega$ .

### **3.15.2 INA2128 Instrumentation Amplifier**

The INA2128 is a low power two channel instrumentation amplifier. Each channel of the INA2128 uses three operational amplifiers in order to achieve a high common mode rejection ratio of 120 dB. The INA2128 also has an acceptable supply voltage range, which ranges from a minimum supply voltage of 4.5 volts to a maximum supply voltage of 36 volts. This an acceptable range as the INA2128 will not be powered by anything less than 5 volts. The next parameter of that will be looked at is the input impedance. The INA2128 has an extremely high input impedance of 10 G $\Omega$ . This input impedance will be suitable for this high current application. The final parameter that will be looked at is the cost, which is one of the negatives of the INA2128. The price of the INA2128 can be quite expensive, at \$12, for a single chip.

### **3.15.3 INA828 Instrumentation Amplifier**

The INA828 is a high precision single channel instrumentation amplifier. The INA828 has many benefits such as the very high common mode rejection ratio, which is around 140 dB. The INA828 also has an acceptable supply voltage range of 4.5 volts to 36 volts, which will not be an issue because the INA828 will not be powered by anything less than 5 volts. The next parameter that will be looked at is the input impedance. The input impedance of the INA828 is extremely high at 100 G $\Omega$ . This input impedance is very suitable for high current applications. The final parameter that will be looked at is cost. The cost of the single channel INA828 instrumentation amplifier is around \$5-\$6. Since only one is needed that price is not too high.

## **3.16 Power Relay**

The ability to remotely turn on or off an outlet or a switch was a key aspect of this system. This ability can be done simply with a power relay. The power relay has

two sides, the control side and the load side. When a voltage is applied to the control side of the relay it closes a switch and allows current to flow through the load side. There are two main types of relays, a typical mechanical switch relay and a solid state relay. The mechanical switch relay uses an electromagnet to pull closed a physical switch, when a voltage is applied to the control side, which allows current to flow through the load side. A solid state relay works by using the light from an LED to control a transistor. When a voltage is applied to the control side light is emitted from the LED and it electrically closes a switch in the transistor, allowing current to flow through load side.

Both mechanical switch relays and solid state relays have their advantages and disadvantages. One key aspect to look at when choosing a relay is the control current. If the control side of the relay requires a lot of current then the device may not be very efficient. Another key aspect to look at is the resistance of the load side. Ideally the resistance of the load side of the relay is  $0\Omega$ , but realistically it is much higher. When the load side of the relay has high resistance there will be a voltage drop across it, which results in a lot of wasted power. This power will be translated to heat, which will require cooling. If the load side of the relay was ideal and had no resistance then there would not be any wasted power and no unintended heating. The next key aspect that was looked into was cost, as some solid state relays can get very expensive. The final key aspect to look into was the size. Since the available space inside the case is quite limited. In the next section the RT1 power PCB mechanical relay was looked at as well as the G3NA solid state relay.

### **3.16.1 RT1 Power PCB Mechanical Relay**

The RT1 mechanical relay is designed to be used on a PCB. The load side of the RT1 relay is capable of withstanding 20 amps continuous current with peak currents up to 30 amps. Ideally the relay will not be required to handle more than 15 amps, but the relay may see currents higher than 15 amps. Because of this the RT1 relay exceeds the requirements. The control side operates in a voltage range of 3 to 36 volts. This is an acceptable range as the relay will need to be powered by 5 volts from the MCU. These specifications meet the requirements of the system, and now the key aspects was looked at. The RT1 mechanical relay is rated to use around 400 milliwatts of power. The load side resistance is ideally very low, so the heat produced should not be too much. The cost of the RT1 mechanical relay is around \$5. Finally the size of the RT1 relay is reasonably small at 29 by 16 by 14 millimeters.

### **3.16.2 G3NA Solid State Relay**

The G3NA solid state relay is an enclosed box that requires wires to be ran to it for both the control side and the load side. The G3NA solid state relay is designed to withstand 20 amps continuous with a heat sink and only 4 amps continuous without a heatsink. The G3NA solid state relay is able to withstand peak currents of up to 220 amps for one cycle, at 60 Hz. This means that if the G3NA solid state relay were to be used then a heat sink is necessary. The G3NA solid state relay also has a turn on voltage range of 4 volts to 32 volts. This meets the requirements so now the key aspects will be looked at. First the power that the G3NA solid state relay uses will be looked at. The power that the control side uses is very small at no more than 20 milliwatts. The G3NA solid state relay can have a voltage drop across the load side of up to 1.5 volts to 2 volts. At max current of 15 amps, this will result in up to 30 watts wasted and converted to heat. This is why it is so crucial to have a heat sink for this particular solid state relay, which affect the already overall large size. The G3NA solid state relay is quite large, coming in at 58 by 43 by 27 millimeters. The minimum size for a heat sink for the G3NA solid state relay is around 100 by 47 by 35 millimeters. This will result in a huge device that will take up a lot of room that is not available. The final aspect to look into is the price. The price of the G3NA solid state relay will cost around \$30, not including the heat sink, which will be a necessary addition.

## 4.0 Strategic Components and Part Selection

Selecting the product that we used from among the products we researched was the next step towards having a functioning system. For each item researched we created specifications for each product type based on what factors of the device are important to our system and assigned scores to each of these categories to attempt to decide which product was the best for the job. In the following sections we discussed which component was selected and why that component was selected over the others.

### 4.1 Current Sensor

The device chosen in order to accurately measure the current flowing through an outlet or light switch is the MSR3 5 milliohm shunt resistor. This device was chosen because it excels in almost all aspects. The shunt resistor will be the smallest choice as it is only a single resistor and an amplifier. The cost of the MSR3 5 milliohm shunt resistor is one of the cheapest options as all that is needed to implement this method of current sensing is the shunt itself, which is at most \$1, and an amplifier, which will again only cost \$2. The MSR3 5 milliohm shunt resistor was the most accurate choice as there is no delay time or nonlinear relationship between current and voltage within certain ranges. The only accuracy issues that may occur when using the shunt resistor are that when the shunt resistor heats up the resistance increases. This means that measuring the current as voltage over resistance will not be linear. The MSR3 5 milliohm shunt resistor however is rated at 3 watts, while ideally the most power that the shunt resistor will use at full load is only 1.125 watts. This gives almost 2 watts of wiggle room to make sure that the shunt resistor does not heat up. The only other accuracy issue that may occur is during the amplification process, however that only took a little bit of tuning in order to get the component very accurate. Because of the power rating of the shunt resistor, it worked well in both accuracy and power dissipation. Since power produces heat it is beneficial to not dissipate an excessive amount of power as this will not only waste power, but it will also affect the accuracy. This shunt resistor as a current sensor does waste the most power of all the choices, however it is an extremely small amount of power at only 1.125 watts. The table below shows the comparison of the three devices.



Table 6: Current Sensor Comparison

<b>Current Sensor Comparison</b>			
<b>Specification (Score out of 10)</b>	<b>MSR3 5 mΩ Shunt Resistor</b>	<b>AC1015 Current Transformer</b>	<b>ACS712 Hall Effect Sensor</b>
<b>Power Consumption</b>	7	9	8
<b>Size</b>	8	5	8
<b>Cost</b>	8	6	8
<b>Measurement Accuracy</b>	9	6	5
<b>Ease of Implementation</b>	7	8	7
<b>Total Score</b>	7.8	6.8	7.2

## 4.2 Voltage Sensor

The device chosen in order to accurately measure the voltage at each outlet and light switch was a voltage divider. This device was chosen because it excels in almost all aspects. It is by far the cheapest option as it is simply just two resistors. Since it is also only two resistors it is also extremely easy to implement. Since the values of the two resistors will determine what the voltage across the second resistor will be, it is simple to get an output voltage in a desired range for the microcontroller to read it. The only thing that will need to be done is a level shift of the waveform, which is done with only two resistors. The size of a voltage divider is tiny, while a transformer is very large and will take up a lot of room. A voltage divider is also very accurate. It took some tuning in order to get an accurate ratio, but once the ratio was obtained there were no issues. The current flowing through the two resistors was very small, so there will be almost no heat, which means that the resistance of the voltage divider will not likely change. The voltage divider will also only waste a very small amount of power, at only 14 milliwatts. Because of all of these benefits, and no negatives, there was almost no reason to pick a power transformer over a voltage divider. The table below shows the comparison of the two devices.

Table 7: Voltage Sensing Comparison

<b>Voltage Sensing Comparison</b>		
<b>Specification (Score out of 10)</b>	<b>Resistor Voltage Divider</b>	<b>Capacitive Voltage Divider</b>
<b>Power Consumption</b>	7	9
<b>Size</b>	9	8
<b>Cost</b>	9	7
<b>Measurement Accuracy</b>	8	8
<b>Ease of Implementation</b>	8	7
<b>Total Score</b>	8.2	7.8

### 4.2.1 Final Voltage and Current Sensor

In the final design, much of the same circuit of both the voltage sensor and current sensor was kept the same. The only difference was that the level shifting was too imprecise for these waveforms. To combat this, our final voltage sensor had a variable voltage shift. Implementing this design did not add a great deal of complexity to our circuit. First, a potentiometer was used create a voltage divider. This voltage was then sent to a unity gain op amp. The output of this op amp went directly to the voltage divider circuit which shifted the waveform up to whatever level the potentiometer was outputting. This allowed us to fine tune the shift of the waveform by turning the potentiometer.

### 4.3 Analog to Digital Converter

The device chosen to perform the analog to digital conversion for the current and voltage sensors was the microprocessor's internal ADC. This was chosen for a variety of reasons. The first reason why it was chosen is that it lowers cost and simplifies design. Adding components costs money twofold. The first is that the price of new components must be included. Additionally, the area of the PCB must be increased to accommodate the new area that the part takes. On top of these issues, the ADC0804 requires its own unique inputs such as filtering, voltage references and clocks. The ADC0804 add unnecessary complexity and adds a much greater potential to cause circuit design issues. Choosing the ATmega2560 as our microprocessor essentially gives us the ADC for free which was a large cost reduction. The second reason the internal analog to digital converter was chosen is it that it met or outperformed low-cost analog to digital converters such as the ADC0804 in all important parameters. The Atmel ATmega2560 has 10 bits for conversion which gives it 4 times more voltage resolution than the competing 8 bit ADC. Additionally, the speed in which it can

sample can be potentially much greater and can easily be set by register modification. The voltage range that it can read from is the same for both at 0-5 volts so they are the same in this regard. The only major downside is that having the processor perform the conversion may consume a significant amount of clock cycles from measuring both the current and the voltage. If this becomes an issue a faster clocked microprocessor or an external ADC may become more viable. The table below briefly goes over all potential analog to digital converters examined and compares their advantages and disadvantages of each component researched.

*Table 8: Analog to Digital Converters*

<b>Analog to Digital Converter Comparison</b>		
<b>Specification (Score out of 10)</b>	<b>ADC0804 IC</b>	<b>ATmega2560 Integrated ADC</b>
<b>Sampling Frequency</b>	8	9
<b>Voltage Reading Range</b>	7	7
<b>Cost</b>	4	10
<b>Accuracy Sample</b>	6	8
<b>Total Score</b>	6.25	8.5

### **4.3.1 Analog to Digital Converter Key Component**

Because the internal analog to digital converter was being used to do the conversion instead of an external analog to digital converter, the supporting components to implement this conversion are all built in within the microcontroller. This however does not mean it is ideal to directly connect the analog signal to the analog to digital conversion pin. While the microcontroller does have some internal safety circuitry, it is not wise to solely rely on it. It is typically dangerous to the microcontroller IC to input more than 5 volts on any pin. Since the analog input is not digital, the voltage that this pin is connected to can vary wildly. To ensure that the voltage does not go above 5 volts on this pin, a safety mechanism needed to be installed on every pin that is doing an analog voltage reading. To facilitate this safety mechanism, the LM431 adjustable precision Zener shunt regulator will be used. This Zener an output voltage that can be set from anywhere from 2.5 volts up to 36 volts. This Zener shunt regulator will be set to trigger at 5 volts through the use of a resistive voltage divider. This will allow any input voltage on the analog pin greater than 5 volts to be capped. Preventing voltages higher than 5 volts to reach the analog pin will protect the microcontroller from being damaged and will ensure even if a signal is over amplified it will remain safe.

## 4.4 Microcontroller

The Microcontroller chosen for our platform was the ATmega2560 from Microchip. This device was chosen over the Parallax P8X32A-D40 and MSP430F6638. First, despite the impressive technical capabilities of the P8X32A-D40, the increased cost and power consumption made the trade-off not worth it. It was also the only one of the MCUs our team had zero experience with. This left us with a choice between the MSP430F6638 and the ATmega2560. The ATmega2560 comes in at a lower price point and slightly lower power-consumption which made it the easy choice looking at it from an analytical perspective. However, what really made it an easy decision to use the ATmega2560 was the development environment and abundance of resources available for the device. All the members of our group have experience creating projects using both the MSP430 based LaunchPad platform and the ATmega2560 based Arduino Uno platform and the unanimous decision among our team was that working with the Arduino based platform was a better all-around experience. The step-through ability of Code Composer Studio is a very helpful feature the lack of supported libraries was a major problem for us here. The abundance of resources available for the Arduino IDE made programming and creating projects using the platform very simple. This allowed for more time to be spent on getting our project up and running and less time troubleshooting strange bugs in our development environment. Table 10 quantifies these various strengths and weaknesses of each device according to a set of specifications that are important to us. As expected the Parallax P8X32A-D40 ranked very highly in the Processor Speed category but the low scores in cost and available resources helped push us away from this device while the Microchip ATmega2560's high scores in Development Environment and Available Resources made it made us more confident in our decision to use it as our system's MCU.

Table 9: Microcontroller Comparison Table

<b>Microcontroller Comparison</b>			
<b>Specification (Score out of 10)</b>	<b>Texas Instruments MSP430F6639</b>	<b>Parallax P8X32A-D40</b>	<b>Microchip ATmega2560</b>
<b>Power Consumption</b>	7	3	7
<b>Processing Speed</b>	4	10	5
<b>Cost</b>	4	3	6
<b>Development Environment</b>	5	5	8
<b>Available Resources</b>	7	2	9
<b>Total Score</b>	5.4	4.6	7.0

## 4.5 Capacitive Power Supply

The power supply selected for our project is the capacitive power supply. This design was chosen for a variety of reasons. First, the project designs do not require a large amount of power. For this reason, the potential power output of other voltage transformation methods such as power transformation and switching mode power supplies are almost completely underutilized in their power output. Secondly, the cost savings of the capacitance power supply are unparalleled. The lack of an expensive transformer and the relatively cheap and small components that it is composed of completely outclass all other designs in both PCB area and component costs. The small number of components also allow for easier circuit design and will make troubleshooting in the case that something does not work, much easier. Because the power supply will not be isolated from the main 120 volts input, special care must be taken to ensure that the internals of the power supply are safely isolated. All external parts must be made of insulating material such as plastic to give good insulation between mains potential and ground. The table below reviews the various power transformation methods researched. Their advantages and disadvantages are compared below and a total score out of ten is given for each method researched below.

Table 10: Power Transformation Comparisons

<b>Power Transformation Methods</b>			
<b>Specification (Score out of 10)</b>	<b>Tamura 3FD-320 Transformer</b>	<b>Würth Electronics Midcom SMPS</b>	<b>Capacitive Power Supply</b>
<b>Size</b>	4	6	8
<b>Potential Power Output</b>	7	9	6
<b>Complexity of Implementation</b>	9	1	10
<b>Cost</b>	4	5	6
<b>Safety</b>	7	10	1
<b>Total Score</b>	5.8	6.2	6.4

### 4.5.1 Key Power Supply Components Selection

There are two important components that must be used to gain the desired effect of stepping the voltage down. Arguably the most important component is the dropper capacitor. This capacitor effectively acts as a large resistor, thus reducing the total current that flows through the circuit. Careful consideration must be made when selecting this capacitor because it must be able to be connected to 120 volts AC and the size determines the amount of current the device can supply. Because of this, a film capacitor must be selected. The

dropper capacitor selected was a KEMET R71VN42204030K. This capacitor is rated at 2.2  $\mu\text{F}$  which allows for the power supply to give roughly 100mA of current. This should be able to power the microcontroller and external peripherals but can be increased in capacitance if needed. The other key component in this circuit is the Zener diode. This diode keeps the output voltage constant and can be set for any output desired. The device selected was the LM431 adjustable precision Zener shunt regulator. This device allows us to accurately set the output voltage at 5 volts with a voltage divider.

## **4.5.2 Final Power Supply Selection**

The capacitive power supply selected initially had some issues that made it unattractive for the final project. The biggest concern of the supply is that it is at mains voltage potential. This made it very dangerous to work with and unsafe for anybody to touch anywhere. The other issue with it was its power output. The final design used much more power than the initial design was planned for. For these reasons the power supply was not used. The power supply that was used for the final project was a 60 Hz transformer. This transformer had a primary and two secondary windings which allowed for both positive and negative voltage rails with a center tap for the ground voltage. These windings were connected in series to achieve this configuration. When in this configuration, the transformer outputs 8 and -8 volts. To make this voltage DC a full bridge rectifier was used with large capacitors to keep the ripple voltage as low as possible. With the output converted to direct current, the voltage was sent to several linear voltage regulators. These voltage regulators stepped down the voltage from 8 volts to 6.9 volts, 5 volts, and 3.3 volts. Capacitors were also added at the input and output of these voltage regulators to keep the signal as clean as possible. These voltages were all the voltages needed for our project which made the 60 Hz transformer a perfect fit for the project.

## **4.6 Digital Temperature Sensor**

The device chosen for the temperature sensing was the DS18B20 1-Wire Digital Thermometer. This device was chosen for many reasons. The accuracy was one of the most important parameters for choosing this device. A large error is extremely undesirable because the actual temperature of the house may fluctuate widely and may keep users much hotter or colder than they desire. This device will give users a very accurate reading of the real time temperature of the household. The voltage range also coincides with the voltage that will be used for the ATmega2560, so powering the device is extremely simple. Additionally, interfacing with the device is very convenient. The DS18B20 has a built-in analog to digital converter which makes reading the temperature extremely easy for the

microcontroller to accomplish. The cost of the device is much higher than simpler temperature sensors, but it is made up by the plethora of built in features and easy implementation. Lastly, the additional feature of having a temperature warning signal when the temperature goes above the set temperature may have been a useful feature to use if designs had changed. The table below goes over the various thermometers researched in chapter three. These researched components are examined by reviewing their advantages and disadvantages and ranking them on a score out of ten.

Table 11: Temperature Sensor Comparison

<b>Analog and Digital Temperature Sensors</b>			
<b>Specification (Score out of 10)</b>	<b>DS18B20 1-Wire Digital Thermometer</b>	<b>MCP9700A-E/TO Thermistor</b>	<b>LMT86-Q1 Analog Temperature Sensor</b>
<b>Accuracy</b>	8	1	3
<b>Temperature Range</b>	9	9	9
<b>Input Voltage Range</b>	5	7	9
<b>Ease of Implementation</b>	8	3	3
<b>Cost</b>	5	10	8
<b>Total Score</b>	7	6	6.2

## 4.7 PCB Software

For our PCB design software KiCAD was selected. The biggest factor for picking this software is the cost. KiCAD is completely free and open source which means all the features that are built in are completely available and not behind a paid service. EAGLE offers a free version, however many of the features and design capabilities are locked behind the paid version such as the number of layers in the PCB design. KiCAD on the other hand, gave us the option of having a larger PCB design and more layers which allowed a much greater degree of freedom in the design process. Atrium would have been the ideal software but the extremely high cost of accessing it made it completely unrealistic to use in an environment that is not a business or large firm. The table below reviews the various PCB software. Each of the software's advantages and disadvantages are reviewed below and the qualities that they have are given a score out ten along with a total score.

Table 12: PCB Software Comparison

<b>PCB Software</b>			
<b>Specification (Score out of 10)</b>	<b>Altium</b>	<b>EAGLE CAD</b>	<b>KiCAD PCB Designer</b>
<b>Ease of Use</b>	9	7	7
<b>Software Features</b>	8	5	8
<b>Price of Software</b>	1	10	10
<b>Total Score</b>	6	7.34	8.34

## 4.8 Display

The display we choose for this system was the Crystallfontz CFAH1602B-TMI-JT. The combination of cost and size was the biggest factor in us choosing this simple 16x2 display over an OLED display. The OLED display we researched was roughly five times the cost of the Crystallfontz display while being roughly the size of a quarter. This means that to get a display of a size that wouldn't be extremely uncomfortable to read would cost a lot of money. The simplicity in programming a 16x2 display was also a deciding factor. Members of our group had experience working with both traditional LCDs such as the CFAH1602B-TMI-JT an OLED displays and have always had much better success in working with LCDs. While this did indeed limit the amount of information we were able to display at our A/C control unit the 16x2 was still sufficient to display all of the necessary information. Table 14 quantifies the strengths and weaknesses of each of these displays based on various specifications that were important to making our decision. Examining the table helps to show just how greatly the CFAH1602B-TMI-JT outperforms the Adafruit display in the viewing quality and cost categories, ultimately leading to it being our display of choice for our system.



Table 13: Display Comparison

<b>Display Comparison</b>		
<b>Specification (Score out of 10)</b>	<b>Crystalfontz CFAH1602B-TMI-JT</b>	<b>Adafruit 0.96" mini Color OLED Display</b>
<b>Viewing Quality</b>	9	3
<b>Character Capacity</b>	3	7
<b>Cost</b>	9	3
<b>Power Consumption</b>	7	5
<b>Hardware Requirement</b>	6	4
<b>Total Score</b>	6.8	4.4

## 4.9 Main Server Operating System

Ubuntu Server is an open source operating system. The operating system is one of many distributions of Linux and is based on the Debian architecture. Ubuntu provides both dynamic page file support and swapping partition support (however swapping partitions are not dynamic). One of the strongest advantages of Ubuntu server is security. Ubuntu server security features include a built-in packet filtering firewall, SSH key support, and role-based access control. Ubuntu server also has expansive driver support which allows it to be run on a wide variety of hardware configurations. Ubuntu Server has a modified general public license (GPL). The license does not require any monetary fees but it does require derivative works that can only be distributed under the GPL licensing terms. The table below shows the advantages and disadvantages of the different operating systems.

Table 14: Operating System Comparison

<b>Operating System Comparison</b>			
<b>Specification (Score out of 10)</b>	<b>Ubuntu Server</b>	<b>FreeBSD</b>	<b>Windows Server 2016</b>
<b>Security</b>	7	8	4
<b>Hardware Support</b>	8	7	6
<b>Ease of Use</b>	9	6	9
<b>Cost</b>	9	3	4
<b>Total Score</b>	8.25	6.0	5.75

## 4.10 Main Server Web Server

NodeJS is an open source, cross-platform server framework. One of the major features which sets NodeJS apart from other web server software is its built in asynchronous I/O support. As a result NodeJS web servers can handle multiple

requests concurrently. Another key feature of NodeJS is that server-side code is written in JavaScript. This helps eliminate traditional web server development boundaries as both the front-end and the back-end code is (in part) written in the same language. NodeJS is not without its flaws however. As it is a relatively young framework, it does not yet support multi-threading in the traditional sense. As a result, NodeJS does not perform as well when handling a high number of concurrent connections. Due to its complexity, support for multi-threading is unlikely to be introduced for some time. Another issue with the age of NodeJS is that it is constantly undergoing API changes. These constant changes are usually backwards incompatible meaning that code must be rewritten to accommodate such changes. The table below shows the advantages and disadvantages of the different web servers.

Table 15: Web Server Comparison

<b>Web Server Comparison</b>			
<b>Specification (Score out of 10)</b>	<b>NodeJS</b>	<b>Apache Http</b>	<b>Nginx</b>
<b>Ease of Use</b>	3	6	8
<b>Security</b>	7	7	7
<b>Performance</b>	7	8	9
<b>Total Score</b>	5.7	7.0	8.0

## 4.11 Main Server Database

MySQL is an open source relational database management system released under a modified GPL license. It is developed by the Oracle Corporation and it is free for private use. To run with the full SQL standard, it must be paired with a version of the InnoDB storage engine. MySQL is cross platform meaning that it can be run on multiple operating systems. As far as ease of use is concerned, MySQL has a large amount of well-written documentation available and an integrated development environment to level out the learning curve. A few key features MySQL offers includes triggers, stored procedures, and (most importantly) secure socket layer support. Having secure socket layer support in a system which handles sensitive information such as ours is invaluable. Access to stored procedure functionality is also useful as it allows the database to offload computational tasks from the web server software. Triggers also offload much of the logging associated with transactions between the WSS and the database. One major issue with MySQL is its lack of built in incremental backups. While most database management systems have this feature implemented and enabled by default, MySQL requires that all tables be backed up explicitly. This increases the overall workload of the project as it requires more extensive testing between version changes. The table below shows the advantages and disadvantages of the different database management systems.

Table 16: Database Management System Comparison

Database Management System Comparison			
Specification (Score out of 10)	MySQL	Redis	MariaDB
Ease of Use	5	6	3
Scalability	7	8	7
Speed	3	3	4
Security	8	6	8
Cost	9	7	8
<b>Total Score</b>	6.4	5.8	6.0

## 4.12 Control Unit Data Transmission Method

Wi-Fi is a wireless communication method which utilizes the 2.4 GHz and 5.8 GHz industrial, scientific and medical radio frequency bands. A significant disadvantage of Wi-Fi is that it is vulnerable to eavesdropping, ARP poisoning and de-authentication attacks. Devices using stock antennas can transmit up to 100 meters without the use of repeaters. Modern Wi-Fi uses carrier sense multiple access with collision avoidance to resolve medium contention. Another major issue with Wi-Fi is that it is significantly less reliable than wired communication methods. Deformation of packets can occur because of both collisions between simultaneously transmitting packets and by interference from external devices. Wi-Fi modules such as the ESP8266 cost around \$7. The table below shows the advantages and disadvantages of the different communication methods.

Table 17: Communication Method Comparison

Communication Method Comparison			
Specification (Score out of 10)	Wi-Fi	Ethernet	RS-445
Ease of Use	10	4	5
Scalability	10	7	3
Speed	6	3	6
Security	8	7	4
Range	10	4	6
<b>Total Score</b>	8.8	5.7	7.3

## 4.13 Discrete Logic Level Shifter

The two main candidates for level shifting considered were the TXB0108 8-bit bidirectional voltage translator and the discrete bi-directional level shifter. While both logic level shifters have the flexibility to do bidirectional logic level

conversion on both the 5 volt and 3.3 volt inputs, a choice between them had to be made. The one selected for this project was the discrete bidirectional level shifter. This was chosen for a variety of reasons. The biggest factor in our design was how easy it would be to implement. At first inspection it would appear that the single TXB0108 package would be the easiest to implement. This IC however is only available in very small packages which makes soldering difficult and routing much more involved. The discrete level shifter however has much bigger surface mount parts which makes soldering and routing easy but also makes troubleshooting easier as well. Additionally, the discrete version is extremely inexpensive. While the TXb0108 costs under two dollars per IC, the discrete level shifter only costs cents per pin that needs to be level shifted. This makes it the most economic choice for our project. Lastly, another advantage the discrete version has over the integrated circuit is that it can be easily scaled. If in the future, another 3.3 volt module is added or it is realized that more data pins need to be shifted, it becomes trivial to add additional shifters. Since each circuit diagram of the shifter is the same, if additional ones are needed it can be easily copied and pasted into the PCB designing software. Because it is the cheapest option while still having the same amount of flexibility of the TXB0108 with the addition of being extremely easy to scale, the discrete logic level shifter was the clear pick for our project. The table below goes over each potential device that could have been used for the logic level shifting. In this table, the key attributes of level shifting are examined and a score from 1 to 10 is given depending on how well each device performs.

Table 18: Level Shifter Comparison

<b>Comparison of Logic Level Shifters</b>			
<b>Specification (Score out of 10)</b>	<b>Voltage Divider</b>	<b>TXB0108 8-Bit Bidirectional Voltage Translator</b>	<b>Bi-Directional Level Shifter</b>
<b>Input Voltage Range</b>	9	6	7
<b>Ease of Implementation</b>	10	8	6
<b>Cost</b>	10	3	9
<b>Flexibility</b>	0	7	8
<b>Total Score</b>	7.25	6	7.5

#### 4.13.1 Key Discrete Logic Level Component Selection

The two main components of the discrete logic level shifter are the resistors and the transistor. While the resistors are not very critical for them to be a specific type or tolerance the transistor used is very important. The component chosen for the transistor is the BSS138. This component is a surface mount N-channel

MOSFET. This transistor is an ideal choice because it has an extremely low resistance between the drain and source when it is in the on state. This means that less power is wasted in the transistor when it is on and there is almost an insignificant voltage drop across it when powered on. Additionally, choosing a MOSFET means that no current will flow through the gate, which greatly simplifies the design and control of the transistor.

### **4.13.2 Final Logic Level Shifting**

The original logic level shifter had issues. The biggest issue with it was that it could not transmit data at the speed required. This caused the ESP8266 to not communicate reliably to the main microcontroller. Because of this the TXB0108 was used. This IC promised fast data transfer rate and a small package. The package however also had issues. The TXB0108 could only output an extremely tiny amount of current. This small current was not large enough to send logic level signals to the ESP8266. Our final logic level shifting was to use a voltage divider. The voltage divider stepped down the 5 volt signal to 3.3 volts. The 3.3 volt signal that was sent from the ESP8266 was directly connected to the microcontroller. This signal did not have to be level shifted because the microcontroller selected could read 3.3 volt logic level signals as logic high. This allowed direct communication between the two devices without any complex discrete circuits or IC packages.

### **4.14 Operational Amplifier**

The two main parts to be considered for amplifying the voltage across the shunt resistor are the OPA2180 2 channel operational amplifier and the INA828 single channel instrumentation amplifier. The reason that these two are the main contenders and the INA2128 two channel instrumentation amplifier is not comes down to both price and the common mode rejection ratio. The price of a single INA2128 two channel instrumentation amplifier is more expensive than two INA828 single channel instrumentation amplifier. This may be an acceptable expense except the common mode rejection ratio of the INA828 is 20 dB higher than the INA2128. Because of these reasons the INA2128 will not be an option when choosing an amplifier. The table below compares the three different operational amplifiers.

Table 19: Operational Amplifier Comparison

<b>Operational Amplifier Comparison</b>			
<b>Specification (Score out of 10)</b>	<b>OPA2180</b>	<b>INA2128</b>	<b>INA828</b>
<b>Supply Voltage</b>	10	8	9
<b>Input Impedance</b>	8	9	10
<b>CMRR</b>	9	9	10
<b>Cost</b>	10	6	8
<b>Total Score</b>	9.25	8	9.25

The part chosen for the amplifier will be chosen is the OPA2180 2 channel operational amplifier and the INA828 instrumentation amplifier. The INA828 will be used for the first stage of the shunt resistors voltage while the OPA2180 will be used for the second stage amplifier and for the voltage sensor protection. The INA828 instrumentation amplifier is chosen for the first stage of the amplifier mainly because of its extremely high common mode rejection ratio.

#### **4.14.1 Final Operational Amplifier**

Originally it was decided that INA828 instrumentation amplifier would be used in order to amplify the voltage across the shunt resistor, however the OPA2180 op-amp was fully capable of amplifying this small voltage. Since the OPA2180 came in a two channel package it was decided that each channel would be used for the amplification of the current signal. The op-amp chosen as the unity gain for the voltage sensing and for the level shifting was the TL084. This op-amp comes in a four channel package. Since no high precision amplification was needed, the TL084 would work perfectly.

#### **4.15 Power Relay**

The two relays to be considered to remotely turn on or off the device was the RT1 power PCB mechanical relay and the G3NA solid state relay. Both of these devices met the requirements of having a turn on voltage of 5 volts and being able to withstand 20 amps continuous through the load side. The table below compares the two devices.

Table 20: Power Relay Comparison

<b>Power Relay Comparison</b>		
<b>Specification (Score out of 10)</b>	<b>RT1 Mechanical Relay</b>	<b>G3NA Solid State Relay</b>
<b>Control Side Power</b>	7	8
<b>Load Side Power</b>	9	4
<b>Cost</b>	9	4
<b>Size</b>	8	4
<b>Total Score</b>	8.25	5

When comparing the power used on the control side of the relay, ideally the control side of the G3NA solid state uses much less power than the RT1 mechanical relay, which uses 400 milliwatts. The RT1 mechanical relay however uses significantly less power on the load side than the G3NA solid state relay. The G3NA solid state relay has a voltage drop of up to 2 volts on the load side, which results in up to 30 watts of wasted power. This is not only a large waste of power, but it also results in a significant amount of heat that requires cooling. This requirement for extra cooling results in making an already large device even bigger. The RT1 mechanical relay is much smaller and does not require any extra cooling. The final aspect compared was the cost. The G3NA solid state relay is very expensive with no extra benefits. Because of these reasons the RT1 mechanical relay was the chosen device.

### 4.15.1 Final Power Relay

The initial power relay selected initially worked but had issues. The primary issue with the relay was that it had switching noise. When the circuit did not have current flowing through the mains line the switching was fine. However, when the circuit had current flowing through it, it caused a large amount of switching noise. This switching noise translated into large voltage spikes that damaged the circuit. To solve this problem, a solid state relay was used. The relay causes a voltage drop which wastes power but it does not have any switching noise. Because it does not damage the circuit, it was chosen as the final power relay.

## 5.0 Related Standards

Standards are an important aspect to consider when designing and building any project. Standards define many ways to implement both software and hardware. These standards give both engineers and users an expected method of communication and interaction between various things. These standards must be observed and adhered to ensure that components can communicate together properly. In addition, safety standards must be followed to ensure the well-being of the user. Some standards we used were strictly followed while others were adjusted based on the unique properties of the project. The most critical standards addressed in this section include "Wireless Communication", "AC Voltage", "Electrical Safety", and "Live Parts Guarding."

### 5.1 Wireless Communication Standards

IEEE 802.11 is a wireless communication standard created and maintained by the Institute of Electrical and Electronics Engineers LAN/MAN committee. The standard is commonly used when implementing Wi-Fi technologies such as wireless local area networks. The standard was created after a ruling by the Federal Commission for Communication agency to open up a section of the Industrial, Scientific, and Medical radio band for public unlicensed use. This standard has undergone many amendments since its first release in 1997. Three amendments which are of direct interest to this project are the IEEE 802.11b, IEEE 802.11g and IEEE 802.11n amendments. The IEEE 802.11b amendment provides a maximum raw data throughput of 11 megabits per second on the 2.4 GHz wireless band. Each channel has a frequency delta of 5 MHz. Devices which use IEEE 802.11b are vulnerable to interference from products which operate in the 2.4 GHz band such as baby monitors, cordless telephones, wireless audio transmitters, microwave ovens and some radio transponders. The IEEE 802.11g amendment expands upon its predecessor IEEE 802.11b. The raw data throughput of IEEE 802.11g is increased up to 54 megabits per second and utilizes the 2.4 GHz wireless band. The performance increase for IEEE 802.11g is due in largely in part to its use of the orthogonal frequency-division multiplexing scheme. The IEEE 802.11n amendment is the latest of the three amendments and as such comes with a variety of feature enhancements. IEEE 802.11n increases the maximum raw data rate throughput to 600 megabits per second by using four separate spatial streams. The IEEE 802.11n amendment has backwards compatibility with both the IEEE 802.11b and IEEE 802.11g amendments and thus support both the 5GHz and 2.4 GHz wireless bands. IEEE 802.11n also provides support for multiple input multiple output modulation scheme and spatial division multiplexing.



## 5.2 AC Voltage Standards

In all houses, the electrical energy that is sent into a residential house is measured in AC voltage. There are two primary competing voltage standards in the world. The standard in Europe is based on a two phase power system that is at a slower 50 Hz but at a higher combined voltage of 240 volts. In America, the voltage standard is very different than the voltage standard in Europe. The standard voltage that is the usual outlet is 120 volts RMS. This means that the standard voltage in a single phase outlet has an amplitude of roughly 170 volts and a peak to peak voltage of 340 volts. This voltage has a standard acceptance of variance as well. At any bus in the system, this voltage is allowed to vary by  $\pm 5\%$ . This means that household voltage can also vary by this amount. This means that the RMS voltage can vary between 114 and 126 volts and still be within the standard accepted voltage.

## 5.3 Outlet Design Standards

Outlet designs standards are a very important aspect that was consider when designing a product that may go to different countries. Along with having different rated voltage outlets, many countries have extremely different outlet designs. These designs have different amount of pins and different pin configurations standards depending on the country. Because our product will remain in America however, we will only consider the American outlet standard. The American outlet has two primary designs for single phase power. The 20 amp outlet has a unique side slot that allows for 20 amp plugs to be inserted along with standard outlet designs. The more common outlet standard is the 15 amp design. This standard design has a neutral slot which is a long rectangle. The hot line, which contains the 120 volts RMS is also a rectangular slot but much smaller than the neutral. The reason this became the standard is it makes it much less likely that something may enter the dangerous voltage side. Lastly, it is standard for all modern outlets to have a ground pin. This ground pin is located at the bottom and is in the shape of a semicircle. This pin serves as another safety parameter to ensure that anything that is connected to the chassis is not at a potentially dangerous voltage.

The figure below demonstrates the basic outlet design standards that must be met for safety and for standard United States of America outlets to work correctly. There is another other typical 120v outlet standard for 20 amperes. This outlet looks extremely to the 15 amp outlet with the exception that the neutral slot has a horizontal slot in addition to the vertical slot. This slot allows standard plugs to be inserted into the receptacle in addition to higher current plugs which have a special design so that they cannot be inserted into 15 amp outlets. This outlet standard, while valid will not be considered when designing our product. The outlet standards that is relevant to our product will be the 15

ampere outlet. The screws are typically used to fasten the neutral and hot wires to the outlet. The polarity that the screws are attached to however is very important for safety and has a standard configuration. The brass screw which is also on the same side as the smaller notch, will attach to the black hot wire. Conversely, the neutral line will connect to silver screw which is on the same side as the bigger notch. Lastly the ground conductor which is either a green wire or bare metal is typically connected to the bottom corner of the outlet. The figure below shows how the lines are connected and how the hot, neutral, and ground connect to the plug receptacle.

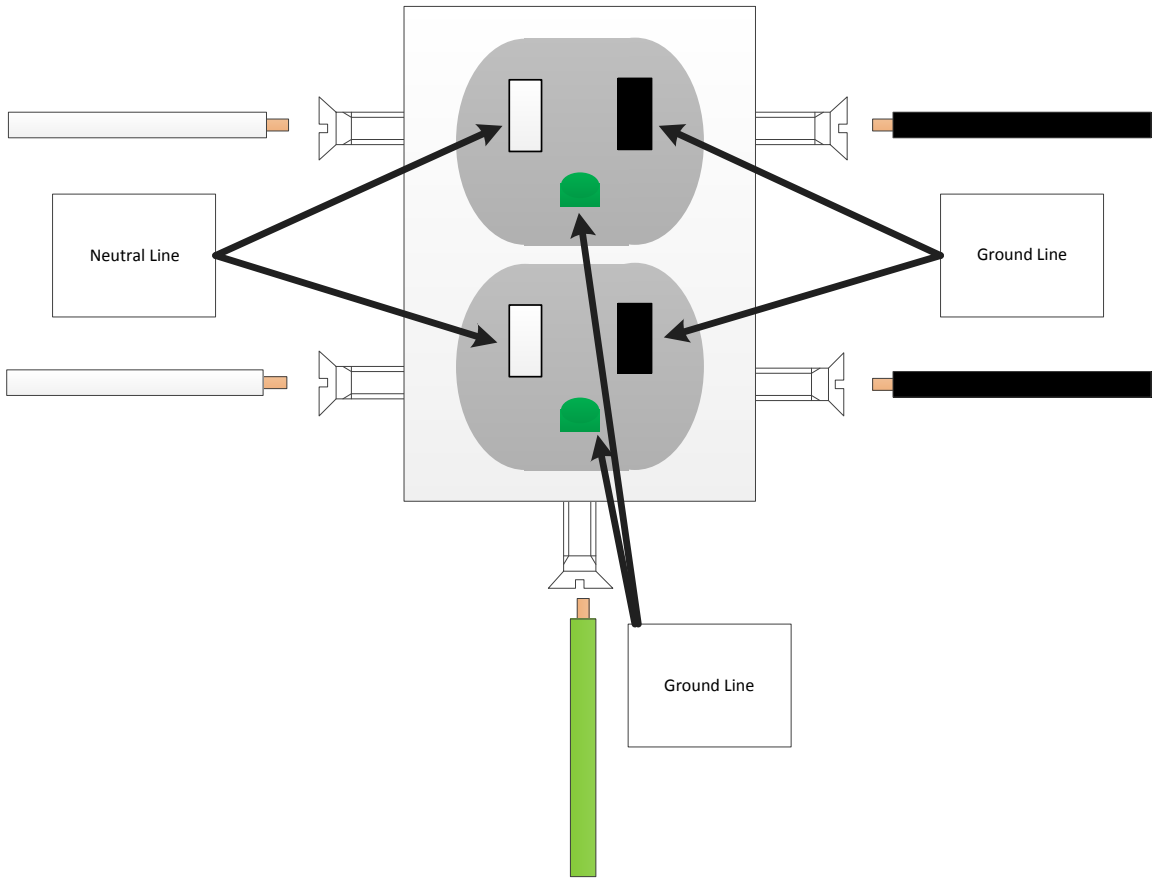

Figure 6: Outlet Diagram

## 5.4 Embedded C Coding Standard

Having a coding standard for software systems is important for a number of reasons. Coding standards help to reduce bugs, reduce complexity of code, and make the code easy to understand for people other than the person who wrote the code. To help promote these ideas we chose to use a standard for programming our MCUs that is based on the Barr Group's Embedded C Coding

Standard. While we will not be describing the entire standard here we will examine the important points that will have the largest impact on our project.

First we examined the more general aspects of the standard. The ground work for this standard was that the program should be written to comply with the C99 version of the ISO Standard for the C programming language. Next, all blocks of code following if, else, switch, while, do and for statements. Both the opening and closing braces shall appear on their own line. Perhaps more than any other line, having consistent and clean bracket usage helps for people besides the author of the code to read the code well. Another important standard is that acronyms and abbreviations should be avoided. This is very important for our project since we have several places for confusion, like 'AC' meaning either air conditioning or alternating current. There was also extensive naming conventions for different data types, variables and functions.

Next we examined some comment standards. The difference between having good comments can make or break the project, as the quality of the comments directly affect the ability for people understand the code they are looking at. Quality comments can help coders quickly identify the cause of bugs that are arising, while poor commenting can cause coders to misunderstand the code and break it further. Importantly this applies to both the original authors of the code and other readers, as coders can often write something and then upon review forget why code was written in a specific way. To maximize to benefit of comments the standard dictates that single line comments started with `'//'` are a preferable to large comment chunks, save for at the start of a program. The other important comment standard was one that is often overlooked, which is that comments should never be used to disable chunks of code. Also all comments should be in the form of complete sentences.

Using these standards did indeed help make our embedded code clean, simple to read and easy to debug.

## **5.5 Design Impact of Embedded C Coding Standard**

Using the Barr Group's Embedded C Coding Standard impacted our software design in a number of ways. By using a well-defined standard the design process in itself became much more systematic, leaving less opportunities for components of the design to be forgotten or mismanaged. Additionally, periodically throughout the design process we chose to have code review sessions in which we make sure our code is matching the standards. If it wasn't, we adjusted the code to make sure it met the standard.

As our MCU was handling different types of data and working with various digital and analog signals, using the naming conventions in the guidelines was needed to help to minimize the chances of getting these different values and data types confused while manipulating them. This was most important when doing

conversion between data types, as it is often easy to forget when an integer is being converted into a double, or other data conversions along those lines. It also helped the designer be aware of what datatypes they are using and explicitly define them as opposed to allowing the compiler to determine the data type.

In general, the use of a standard greatly streamlined the design process and made any debugging or troubleshooting that needed to be done less of an obstacle which ultimately made completion of the design much easier.

## **5.6 Electrical Safety Standards**

Electricity is a very useful but potentially dangerous utility that people deal with every day. To protect users from an extremely painful or potentially deadly shock, there have been many safety standards that minimize the chance that someone can accidentally encounter these voltages. OSHA discusses many of these safety standards.

### **5.6.1 Live Parts Guarding**

One of these electrical safety standards is the guarding of live parts. This standard is designed to protect any person against accidental contact. This is to prevent unqualified or untrained people from accessing live parts. This guarding of live parts must be done on any equipment operating at 50 volts or more. Because our devices will be operating at 120 volts RMS, this safety standard must be adhered to in our project. To guard high voltages, there are certain acceptable methods to guard live parts. The first is to have the live parts in a room that is only accessible by authorized people. Because our project is designed to be accessed by any user this method of guarding is infeasible. The second method of guarding is by placing it on a suitable balcony, gallery, or platform. This method of guarding is once again not applicable because of functions they will provide. The third method is to place components that have live voltage out of reach. For this to meet safety standards the live part must have an elevation of 8 feet or more above the floor. This height must be higher if there are materials that may come in contact with this height however. The last acceptable standard for guarding live parts is to be enclosed by permanent, substantial partitions. These partitions so that only qualified people will have access to the live parts. If the device has any openings, the openings must be small enough that accidental contact with any live parts is extremely unlikely. Lastly, the use of covers or screens that the live parts can only be accessed with the use of tools is not required but good design that makes people less likely to violate the safety standard. This is the route that our project will take to meet the safety standard of guarding live parts. Our design was in an enclosure to ensure that users will not have access to the live parts.

## 5.6.2 Conductor Identification Standards

Another important safety standard is conductor identification. All wiring systems for transmitting power have a neutral line, and almost all facilities, with the exception of places that have extremely old wiring infrastructure have a ground line. These two lines must meet standard coloring schemes to make them easily identifiable to users and qualified electricians. The grounded conductor, which is typically referred to as the neutral line, must be protected with an insulator. While the neutral line is typically not energized, certain faults may cause it to become energized and become a hazard to touch. To identify the neutral line, there are two standard colors for this line. The insulation of the neutral line must be either continuous white or a natural gray color. The other line that must have an identification standard is the ground conductor. The ground conductor has two standards of identification. The first is bare conductor. This means that the ground wire has no insulation or covering. Because this wire has earth potential however, it is safe to leave uninsulated. The other standard for ground wire is to insulate it with a green color. This insulation is a continuous green with one or more yellow stripes. Lastly, the live wire that contains the voltage does not have a standard color. For this reason, the ungrounded conductor can be any color other than the colors used for the neutral line and the ground line. To meet these standards, the smart home energy monitoring system has any wires connected to the mains power to be colored in the same manner. Our modules has the white wires connecting to the neutral conductor and bare wires for anything that connects to the ground conductor. For the ungrounded conductor we used a black insulated conductor. While there is no standard that says it has to be this color, it is very typical for house wiring to use this color.

## 5.6.3 Polarity Standards

In the three-line system, each line has a dedicated purpose. In many cases, equipment that is plugged into a receptacle will still work even if the polarities on the lines are incorrect. This improper connection is most common in smaller circuits that run on 120 volt outlets. While this improper connection may still work, the device or appliance has the potential to become extremely dangerous. One of the most common incorrect polarities is exchanging the hot and neutral line. While this typically will not cause a shock hazard, it may cause internal damage to the device. The most dangerous incorrect polarity is when the live wire is connected to the ground and is connected to the neutral line. Because the ground wire is typically connected to the chassis of the device, this causes the live 120 volts to be connected to the case of the device. With this configuration, the device that is plugged in will not work. In addition, touching the outside case could cause a potentially fatal shock. To ensure our project meets polarity standards, the wiring was done very carefully. Because the outlet that we use is

a standard United States outlet, the wiring to it will have to be correct as well. The standard polarity has the hot black connected to the brass terminal. The neutral is hooked up to the silver colored screw. Lastly the ground is attached to the green hexagonal head screw. Following this wiring configuration will also ensure that we will follow polarity standards which will make the device much safer.

## **5.6.4 Grounding Standards**

Grounding is essential for safety. The two type of grounding is circuit grounding and electrical equipment grounding. Equipment grounding has to deal with physically tying the system to the earth. This is in place to protect the user and circuit from high voltage such as lightning strike or high voltage contact such as from a short. The grounding provides an electrical path for dangerous voltages to return to system ground when a fault has taken place. This path allows protective devices to work such as breakers or fuses. This grounding path has a number of standards to ensure it works as designed. The first standard is that the ground line must be permanent and continuous. The second is that the ground must be able to safely handle any fault current. This standard exists because if it cannot handle the fault current then it might not trigger safety devises such as the breaker. The third standard is that it has to have low enough impedence to limit the voltage to ground and to facilitate the operation of circuit protection devices. This is because if the impedence is high, there might not be enough current to trigger a breaker. Equipment must be grounded if it is operated at over 150 volts.

## **5.7 UART Standards**

Universal asynchronous receiver-transmitter is a standard for digital communication between two devices. UART allows for varying data formats and transmission speeds. In UART data is transmitted in sequential packets between devices in simplex, half duplex or full duplex mode. In simplex mode, data transmission occurs in one direction (from sender to receiver). In half duplex mode, data transmission can occur in both directions but only in one direction at a time. In full duplex mode, data can be transmitted between both devices simultaneously. Standard UART devices contain the following components: input/output shift registers, clock generator, transmit/receive control. The inclusion of a memory buffer is recommended but not required. UART data packets consist of 1 start bit, 5 to 9 data bits, 0 to 1 parity bits, and 1 to 2 stop bits. The start bit is used to initialize the transmission. The data frame consists of the data that is being sent. The parity bit is used to check for data transmission errors. The stop bits are used to signal the end of the data transmission.

## 6.0 Realistic Design Constraints

The project had a wide variety of design constraints to consider. Some constraints were addressed with dedicated modules while others were discarded due to logistic constraints. There were some constraints that were self-imposed due to the goals of our project and its focus on saving energy. Other constraints arose due to us being students with limited time and resources. Other constraints would be present for anyone trying to create a system that is intended to operate off home electrical wires. Included in this section are all of these constraints which and the manner in which they were handled.

### 6.1 PUR and DSC

A critical constraint we had to consider when making system design choices was data storage consumption (DSC). Power usage resolution (PUR) was one such design choice. PUR refers to number of power usage measurements for a given period of time (per second, per minute, hourly, daily, etc.). In the ideal system we would be able to record the exact power usage for a control unit at any point in time over any amount of time. However due to real world data storage constraints we had to limit the PUR to a value which the system could realistically handle and the user would be satisfied with. PUR is dependent upon the effective power usage measurement frequency (EPUMF). EPUMF refers not to the rate at which the control unit actually measures its power usage. The control unit takes the average of the actual rate to estimated power usage readings. The main server interprets these readings as having occurred at a slower frequency. This slower frequency is the EPUMF. The higher the EPUMF, the more measurements are taken over a period of time and the higher the PUR. The lower the EPUMF, the less measurements are take over time and the lower the PUR. The EPUMF determines the overall data storage consumption of a control unit over a period of time. Below is a table showing the relationship between EPUMF and the number of stored power usage measurements (SPUM) made hourly/daily/weekly/monthly to accommodate each frequency. If a control unit measures the power usage at a rate of 10 readings / cycle on a standard 60 Hz AC outlet and reports readings to the main server as an average of all the readings it takes in a second then the EPUMF will be 60 Hz. Even small EMPUF value for a single control unit such as 1 reading every second has a monthly SPUM count that would consume a considerable amount of storage. The table below shows the relationship between EPUMF and data storage.

Table 21: EPUMF vs Data Storage

EPUMF (Hz)	Minute SPUM Count	Hourly SPUM Count	Daily SPUM Count	Weekly SPUM Count	Monthly SPUM Count
1/600	0.1	6	144	1008	4032
1/60	1	60	1440	10080	40320
1	60	3600	86400	604800	2419200
60	3600	216000	5184000	36288000	145152000
600	36000	2160000	51840000	362880000	1451520000
6000	360000	21600000	518400000	3628800000	14515200000
60000	3600000	216000000	5184000000	36288000000	1.45152E+11

We developed a solution to deal with this issue known as the "Power Usage Measurement Average" (PUMA) system. The purpose of PUMA is to average power usage readings over time intervals to reduce the overall amount of stored readings. For example, say the power usage measuring module on the Arduino measures at a rate of 600 Hz (600 readings per second) and starts taking measurements at 00:00:00 on Sunday. Over the next second (00:00:00-00:00:01) the PUMA will accumulate a sum of each reading. At the end of the second the PUMA will take the average of the readings and record it. This process then repeats for each second until end of the current minute 00:00:00. At the start of the minute 00:00:01 the PUMA takes the average of the 60 second-by-second averages over the past minute and records it. The 60 second-by-second averages over the past minute (00:00:00-00:00:01) are discarded. The PUMA then repeats this process every minute until the end of the current hour (00:00:00). At the start of the next hour 01:00:00 the PUMA takes the average of the 60 minute-by-minute averages over the past hour (00:00:00-01:00:00) and records it. The 60 minute-by-minute averages over the past hour (00:00:00-01:00:00) are discarded. This process repeats for every hour until the end the current day (24:00:00). At the end of the current day the PUMA takes the average of the 24 hour-by-hour averages and records it. The 24 hour-by-hour averages taken over the course of the current day are then discarded. This processes then repeats until the end of the current month. At the end of the current month the PUMA takes the average of the daily power usage averages for that month. The daily averages over the current month are discarded. This process repeats until the end of the current year. Monthly averages are not discarded. By taking averages over multiple levels (cycle, second, minute, hour, day) accuracy is lost. However, this trade-off is necessary in order to avoid overloading the main server.



## **6.2 CU/MS Network Performance Constraints**

Another key constraint we had to consider was the performance of the network which acted as the medium between the control units and the main servers. The control units use Wi-Fi to connect to main server. Wi-Fi is subject to a significantly higher collision rate and is more vulnerable to external electromagnetic interference than wired connection methods such as Ethernet. To compensate for the lack of reliability we chose to use transmission control protocol (TCP) as the primary communication protocol between control units and the main server. TCP increases the reliability of transmission but at the cost of additional overhead. We chose to favor reliability over speed as we felt a faster system with unreliable data would be considered much worse than a slower system with reliable data.

## **6.3 Air-Conditioning Unit Constraints**

The availability and feasibility of using a real air-conditioning unit in our project was a huge constraint we needed to navigate. In a real-world implementation of our system our air-conditioning control panel would be interacting with a real air-conditioning unit. Unfortunately, these are massive objects that cost thousands of dollars and aren't portable. Also modifying the wiring of a real unit would require very intrusive modifications. We attempted to handle this constraint in several ways. First, to allow for a more realistic picture to be given to the user in the web interface, we spoofed the air conditioning power values in our database. We considered still monitor the power we have going through our load there and sending that information to the database to prove successful monitoring as well, however we decided against this as the other units demonstrate this concept. We had also considered attaching a fan as a load that would turn on under certain conditions and monitoring this power usage. In the end, for our project purposes, when the user set the temperature of the thermostat lower than the temperature or higher than the temperature by a number of degrees, we turned on or off indicator LEDs. While these LEDs are on we spoof power data to the server. While working with the real thing would have been ideal these concessions were a way for us to realistically navigate the constraint placed on us by the difficulty of working with a real air-conditioning unit.

## **6.4 Microcontroller Memory Constraints**

In this project we hoped to use the microcontroller to do many things, particularly at the thermostat. However, attempting to perform a wide set of tasks with a microcontroller presents some unique constraints. Particularly we saw these

constraints arise with memory available on some microcontrollers. Originally, we planned to use a 32kb version of the microcontroller we selected, but after some early prototyping we realized this would not be feasible. This was because many of the features we wish to incorporate require their own libraries be stored on the device. Some of the libraries, like those required for the thermometer, needed 15kb for their libraries. There are a number of approaches that can be used to try to reduce the size required by libraries. One approach is to manually go into the library files and extract the parts of it you need, thus reducing space. This can prove effect when dealing with large libraries for things such as math functions, where parts of the libraries are isolated and can be individually extracted without risk of breaking the program. However, for libraries such as those required to perform serial communication, extracting the necessary components can be tricky. Often the entire large library is required to have desired behavior. If not, it is very complicated to extract the desired parts without breaking the system as these libraries tend to be much more interdependent than other libraries. The table below provides further insights into some of the libraries and their size requirements. The solution we decided on was to simply switch which microcontroller we were considering. The final microcontroller that was settled on was almost identical except for more I/O pins and the larger memory. External memory modules were also considered. The main advantage of using these external modules was the lower cost when compared with buying a microcontroller with more memory. However, these devices do not perform well with runtime data, and instead are more suited for storing large blocks of static data, like a look-up table. Since this is not why we needed the extra memory, this solution turned out to be a bit of a dead end. Choosing the solution of the microcontroller does increase the cost of our system, along with increased difficulty to solder the chips, as the only package available for the larger memory version is a 100-pin package. However, we believe these tradeoffs were worth it considering the other option was a non-operational system.

*Table 23: MCU Library Size*

<b>MCU Library Sizes</b>	
<b>Library</b>	<b>Size in KB</b>
<b>SoftwareSerial</b>	17
<b>EEPROM</b>	6
<b>OneWire</b>	24
<b>LiquidCrystal</b>	12

## **6.5 Economic and Time Constraints**

Being a self-funded project, it was important that we keep our budget as low as possible. However, saving money does not simply mean buying the cheapest parts on the market, and this is for a number of reasons. First, using cheap products could easily break unexpectedly causing lots of problems, especially if it isn't obvious to the naked eye that the part is broken. This could have easily end

up costing more money in the long run. Also, we wanted to make sure that we didn't buy cheaply made parts, so we can ensure they were accurately measuring the data in our system. As one goal of our project was to help the users of the system save money it was better to invest slightly more at the time of construction in order to help more money be saved while the system was in use. What is important is finding a balance on the return on investment for the user is efficient. When the topic of other power saving technologies came up, such as solar panels, a common point of discussion is how long it takes for the cost in energy savings to pay for the cost of the device. Keeping this in mind we were constrained to a sweet spot where we spend enough money to ensure a quality system while still leaving the potential for a reasonable return on investment time. There are a couple things we did do to help minimize the negative effects of these constraints including thorough research to help reduce unnecessary spending and reusing as many components from testing into the final build of the design, thus minimizing spending on parts.

Along with the economic constraints there were also a number of time constraints to be considered. The plan for the design needed to be finished by end of the Spring 2018 semester at UCF. Likewise, the final build of the project needed to be completed by the end of the Summer 2018 semester at UCF. This narrowed the amount of time we had to troubleshoot any problems we encounter along the way. To help minimize this constraint we began prototyping individual units within the system before the entire design was finalized so that when it was time to begin work on the final version we already had been comfortable with the individual sections. Additionally, as our project correlates data with time, we were constrained by time in another way. Our system allows the user to view their power consumption over a previous number of months and compare it with their current usage. However due to the time constraints of our project we could allow our system to run for months collecting data. To minimize the effect of this constraint we instead populated our database with values to demonstrate the functionality of the system, instead of capturing the data.

One key time constraint lied in the case design of the control units. There were two options for the case: buying a premade plastic case or 3D printing a case. Buying a case has a shipping time constraint on average of two to three weeks. 3D printing a case has a time constraint which consists of the design time, system tuning time printing time and (if printing fidelity is insufficient) finishing time. For these reasons 3D printing a case for the prototype would be far too time consuming. Instead we opted to buy a premade case for the prototype. In addition, we chose to attempt to design a 3D printed case for the final product and order a premade case as a backup plan.

## 6.6 Environmental, Social and Political Constraints

Our project revolved around reducing the amount of power people use in their home. This is a very environmentally focused goal; therefore, it is important for us that we understood the environmental constraints on our project as to not betray our objective. We were able to do this by minimizing waste by not excessively ordering components or throwing away components that are still potentially useful. Likewise, when we disposed of any material that could potentially be harmful to the environment is very important that we followed the proper protocols for disposing of harmful waste. When dealing with electronics it is also possible for the heat caused by energy dissipation to burn materials releasing potentially harmful contaminants into the air. We minimized our chances of this happening by properly examining our circuit before we apply a signal to it, so that it does not behave unexpectedly and cause an issue.

Social issues for our project fell upon the group members. There are four members in this group which can be a lot of moving parts. The completion of this project is also determinate in whether we successfully graduate, which caused a lot of stress. These factors had the potential to combine to create discord within the group. Working many hours, a day with the same people in a high stress environment could lead people to snapping at each other and becoming easily irritated irrationally. Therefore, it was our job to attempt to minimize these stresses and properly defuse situations if tensions get high. There are several ways in which this was able to be done. The first one was simple, to avoid procrastinating. Scrambling to complete a project last minute will very quickly raise tension among team members but starting work quickly and maintaining a consistent work schedule can help to minimize the chances of this happening. It is also important for the team to have clear and open communication along with being understand of the other group members. On a larger scale, there are a couple other social constraints on our system. Recently there are many news pieces about various security breaches that occur because of poor design in different 'Smart' devices. To negate this, we would need to demonstrate the security advantages of our system and make sure the core functionality of the devices, such as the light turning on when the switch is pressed, still operational even if the network is down.

The large scale social constraints are also making way for the potential of increased political constraints on our project. The plethora of recent safety, security and functionality problems that have arisen in the internet-of-things sphere has some people calling for increased oversight on these devices. While no such legislation yet exists, it is important to be aware that this is a factor that may become a larger problem down the road. Lastly there is political constraint in the form of electrical standards that we must adhere to. There are all sorts of regulations pertaining to how electricity in homes must be, so we have no choice but to adapt our system to these sorts of constraints. It is our job to design a system that works within these preexisting constraints.

## 6.7 Ethical, Health and Safety Constraints

When creating any sort of project, it is very important to consider the ethical constraints that apply. For our system there were a couple of ethical constraints that we needed be very mindful of. First of all, our system was informing the user of their power consumption which has a direct financial cost associated with it. It would be very unethical if we knowingly were under-reporting the user's power consumption then when their bill arrives the cost is much higher than they expect. Therefore we strived to be as accurate as we could with our power usage data. Additionally, the use of Wi-Fi in our system created additional ethical constraints on our project. Our system needed to be able to operate even when they weren't the only devices connected to the user's Wi-Fi network. Therefore, it was important that we did not knowingly leave any security gaps in our network functionality that could end up harming the user. Likewise, it was important that our system require user authentication before connecting to the network.

When working with high-power sources health constraints quickly arose. We needed not to pose any threat to health in our system by anything such as exposed wiring or other active power components, or materials that could harm the user. To further this goal, we used safe materials to house our components that were able to withstand both the heat and the electricity that they were experiencing. Likewise, the members of our team were vulnerable to these same sort of health risks, especially when working in the lab during testing. To help minimize the risk to our team members it was important for them to practice proper lab safety when operating devices such as soldering irons or exposed electrical hazards. This included practices like wearing lab goggles when soldering and using an electrostatic discharge bracelet when working on the electronics equipment.

Working with objects that were operating with the wiring in a home introduced several safety constraints as a result of various electrical safety standards. One of these is that someone cannot be able to reach the live hot components easily. Our outlet must also have a constant connection to ground in order to prevent injury. These constraints are for the safety of the users and therefore it is important that adjust our design to meet these constraints as it is overall beneficial. To meet these standards, it is our responsibility to make safe housing units for the devices in our system so that they do not pose a safety risk to anyone who either works with them or uses them. Likewise, it is important for us to take steps to ensure the safety of the team members in the lab. This can be accomplished by wearing electrostatic discharge bracelets when working with equipment and taking care when soldering components on to the PCB.

## **6.8 Manufacturability and Sustainability Constraints**

Being a student project with a tight time schedule there were expectedly several manufacturability constraints that we needed to be ready for. First, we did not have access to any high-quality 3D printing stations, nor did we have anyone specialized in designing housings for electronics. This meant that we will not be able to create housing for our units that will fit into standard outlet boxes or light switch sockets. To overcome this, we instead purchased larger housings out of materials that are easy to work with while still maintaining the safety properties that are essential when working with electronics. Another major manufacturability constraint came down to that of the PCB. We had no way ourselves of manufacturing a PCB but instead needed to rely on third party vendors to manufacture the PCBs according to our designs. Since there was a few week turnaround from submitting the order to one of these PCB manufacturers to receiving the PCB it is important that we got an early start on this, so that in the case of a fault in our PCB we had sufficient time to order and test new PCBs.

With any project based on saving power, sustainability constraints certainly become a factor. This came down to making sure our system's lifespan lasted to maximize return. One reason for this is the higher cost often associated with various products designed to save energy. These products come at a higher initial cost than the non-specialized equivalents. For the consumer the consideration comes down to paying a higher initial cost that is offset in savings overtime. Having a sustainably designed device attempted to maximize the lifespan of the device, in turn maximizing the potential return on savings. Sustainability was also important beyond the lifespan of the device. We did not want to use materials in our device that required an abundant amount of resources to create, nor did we want to use materials that have a negative impact on the environment when they are disposed of. Where the sustainability constraints really become noticeable is when the effect is viewed from an economic lens. If our system were to be competing against similar products that are not created with a focus on sustainability they may be able to produce their item at a lower cost thus driving us out of the market. To help to negate the negative impact of these various sustainability constraints we attempted to do extensive research to find materials and components for our design that were a good combination of quality and cost.

## **6.9 MySQL Database Standards**

We followed a series of database standards enhance the performance and overall structure of the database. Constants labels will be written in all uppercase with underscore separators. Variable labels will be written in camel casing with the first letter being lowercase and uppercase letters acting as separators. All labels shall be no longer than 32 characters in length. Variable may consist of at

least 1 letter and may be followed by either letters or numbers. Variable labels and procedure labels must relate directly to their function. The database shall be normalized in third normal form. To be considered third normal form, a database must first be in second normal form and every non-prime attribute of every table must be non-transitively dependent on every key within their table. To be considered in second normal form if the database and every non-prime attribute is dependent on the whole of every candidate key. A database is in first normal form if the domain of each attribute contains atomic values.

## 7.0 Project Hardware and Software Design Details

This section provides a comprehensive explanation of the design of critical hardware and software components in our project. In addition, it also provides a macroscopic overview of the hardware and software systems in use. The goal of this section is to have addressed every part of our design and have a plan from top to bottom for our system to operate. From a hardware standpoint this consists of making sure that any signals that must be adjusted to provide power to components or have outputs connected to things such as ADCs are considered and planned for. From a software standpoint we wanted to address how any devices that need to communicate will do so, how data will be handled throughout our system and logic decisions made within our system.

### 7.1 Control Unit Modules

The figure below shows the software modules which need to be created in order to implement the control unit functionality specified in the Goals and Objectives section. Each module is to be implemented separately as either a class or set of functions (class is preferred) and then integrated using Main Loop code. The main loop is primarily responsible for handling initial startup which involves determining the current startup mode, verifying that all components are connected/functioning and calling either the setup mode module or the connect mode module. Once control is transferred to either mode module the selected module maintains control until either the device is powered off or reset. The switch controller module is responsible for controlling the relay which connects the incoming AC power input to the outgoing AC power ports (and ultimately the devices connected to them). The temperature measuring module is used to measure the ambient room temperature using a one-wire temperature sensor. The LCD screen controller is only included on AC control units and is used to display power usage data onto the LCD screens attached to AC control units. The power measuring module is used to measure the power usage of both the control unit and connected devices over a period of time. The power measurement storage module is used to store power measurement readings in both non-volatile and volatile storage. The web server module is used by the setup mode module to implement a web server on the control unit's network. The Connect/Setup mode push button handler is called whenever the connect/setup mode push button is pressed and is responsible for changing the control units mode. The main function of the time tracking module is to maintain the current shared system time between the control unit and the main server. The Wi-Fi main server communication module is responsible for handling all data sent to the main server and all commands received from the server. The setup mode and connect mode modules act as additional main loops which implement the



behavior of the control unit for their respective modes. The figure below shows the modules that need to be created for the control unit software.

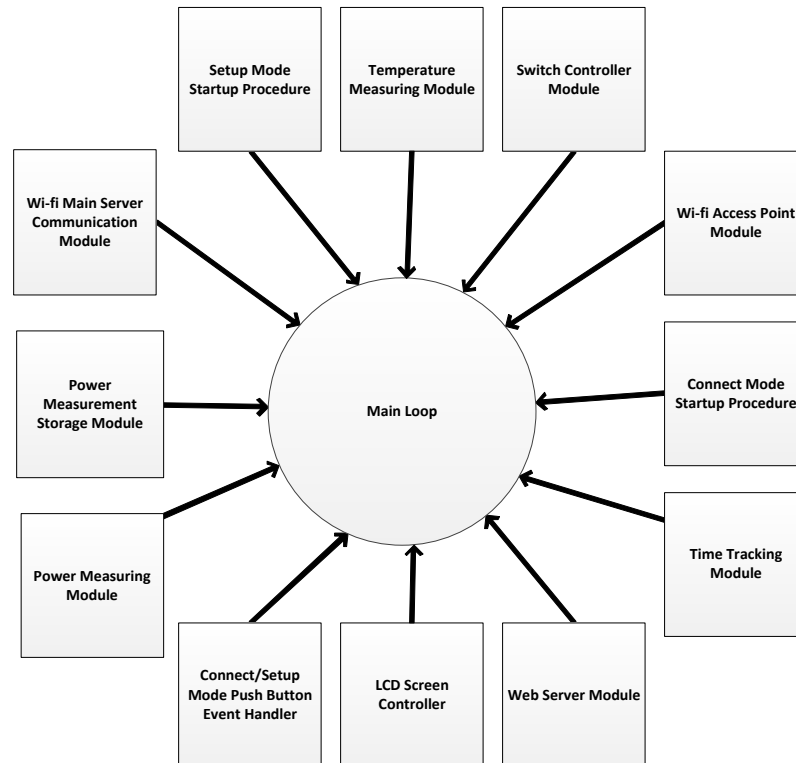

Figure 7: Control Unit Modules

## 7.2 NodeJS Server Modules

The figure below shows the software modules which need to be created in order to implement the main server functionality specified in the Goals and Objectives section. The control unit handler is responsible for handling all interaction between the main server and control units. It will be used to send commands to the control unit and to receive and process data from the control units. The control unit handler is also responsible for handling authentication of a control unit using the MySQL database interface. All data sent between the control units and the control unit handler is encrypted. The MySQL Database interface is used to read and modify the main server's MySQL database. The web browser interface handler is responsible for implementing the main server's user web browser interface. It is also responsible for authenticating all users using the MySQL Database Interface. All data sent between users and the web browser interface is encrypted. The IP Tables Interface module is used to control the main server's firewall settings. The Main module acts as the foundation on which the other modules are run on. The figure below shows the modules that need to be developed for the main server.

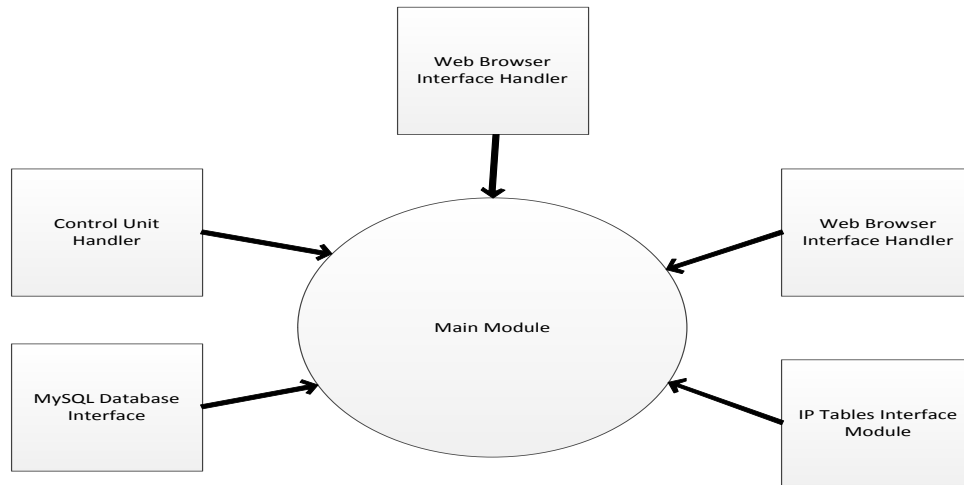

Figure 8: Main Server Modules

### 7.3 Connect/Setup Mode Logic Flow

Upon first boot the control unit will start in set up mode. After initial boot if the user presses the setup/connect mode button while in set up mode the control unit will restart in connect mode. When the user presses the setup/connect mode button while in connect mode the control unit will restart in setup mode. As long as the control unit's configuration parameters have not been modified it will start in setup mode. The flow chart shown below illustrates the logic behind this.

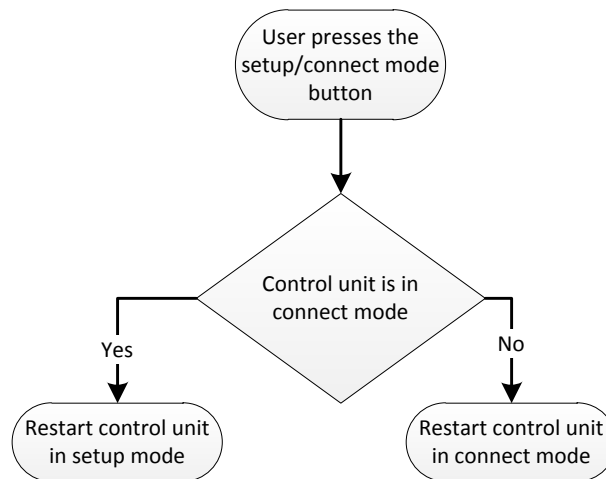

Figure 9: Control Unit Setup/Connect Toggle

Whenever the control unit powers on with default configuration settings or the control unit mode variable is set to setup mode it will start in setup mode. When in setup mode the control unit will create its own Wi-Fi network and sets up a

web server on it. After the web server and Wi-Fi network are initialized the setup mode main module is initialized.

When in connect mode the control unit will attempt to connect to the Wi-Fi network specified with in its configuration parameters with the credentials provided in its configuration parameters. If the control unit fails to connect it will periodically attempt re-connection. Once the control unit has successfully connected to the user Wi-Fi network it will attempt to establish a connection with the main server. If the control unit is unable to connect to the main server, it will periodically attempt reconnection. Once the control unit establishes a connection with the main server it will call the connect main module. The figure below shows the flow chart for the control unit power on sequence.

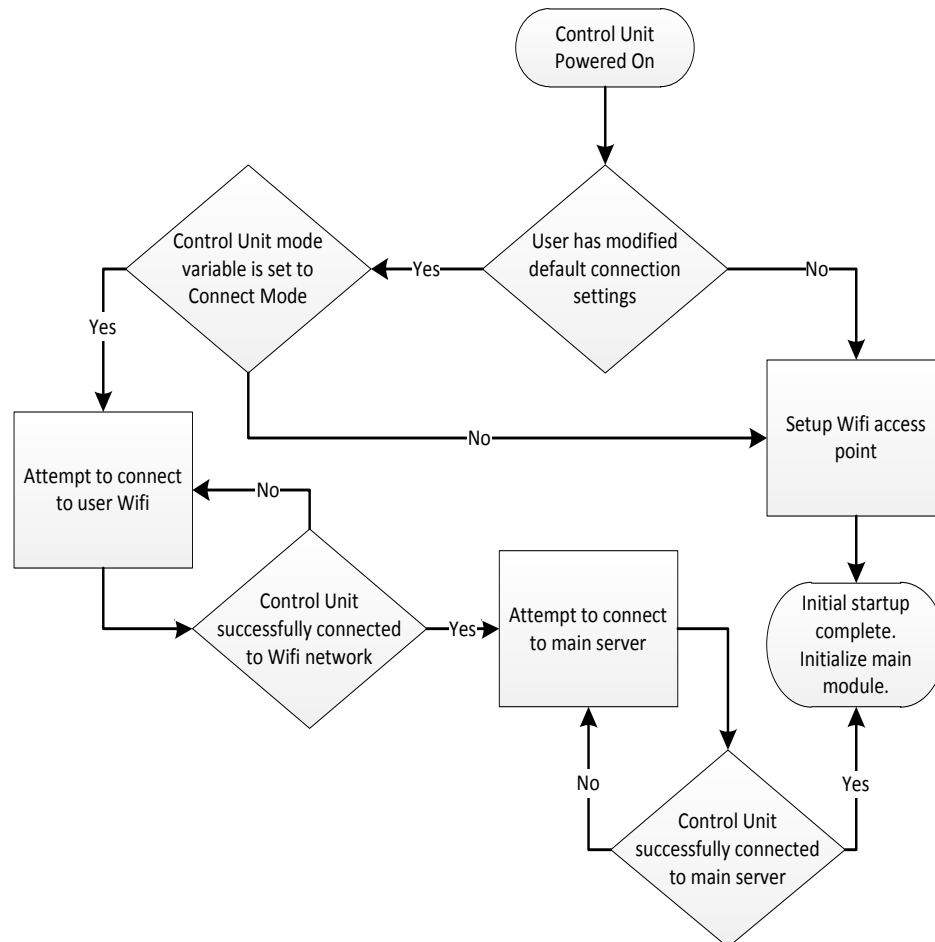

Figure 10: Control Unit Power On Flow Chart

The Wi-Fi network id and password will be varied for each control unit. The user can connect to the Wi-Fi network using a Wi-Fi enabled device. Once connected to the control units Wi-Fi network the user enters the IP address of the control unit (which is the same for each unit) into their browser and requests the control unit web configuration interface from the control unit. The user then uses the interface to modify the control unit's configuration parameters so that it can

connect to the user's Wi-Fi network. The user then switches the control unit into connect mode. If the control unit establishes a connection with the main server, it will determine the current time using the main server. Once the current time has been determined the control unit will determine its current time slot and begin periodically sending power usage data packets to the main server. Power usage data packets consist of two main elements: the recorded power usage measurement for a given time slot and the time slot in which the measurement was recorded. The control unit will respond to switch control commands received from the main server by switching the outlet on or off. When in connect mode the control unit alternates between two sub modes: record and transmit. While in record mode the control unit will record power usage data for the current time slot. At the start of transmit mode the control unit will send the oldest power usage data packet in its buffer to the main server and wait for the main server to reply with either an acknowledgement or a command.

## **7.4 Power Loss Recovery Program Flow**

While our system was 'Always-On' when in operation, there are times when the various devices could have lost power. This could have been due to an unexpected event, such as a sudden power outage, or due to the user simply wanting to turn the device off for their own reasons, such as going out of town for a period of time and not wanting to waste energy. After events like these occurred we wanted our system to be able to recover on its own and not require reconfiguration from the user or for anything to be reloaded on to the MCU. To do this will use the non-volatile memory built-into the ESP8266. Figure 11 shows how this process will be implemented. Upon startup, the system will check if there is Wi-Fi connection credentials stored in the EEPROM. If not, the system would simply enter the normal setup mode that would occur when the system is booted for the first time. If there were Wi-Fi credentials stored the system will search for the network and attempt to connect. If the matching network was not found, the system would continue to search until the user manually presses the enter setup button, upon which the device will enter the standard setup mode. Likewise, if for any reason the network was found but the device is unable to connect to the network it would continue to attempt to connect to the network until the user presses the configure button upon which the device will enter setup mode, or the system connects successfully. Upon successful network connection than operation would resume normally. The reason for having the devices reattempt both network location and network connection was to ultimately make it more user friendly. In the event of a power outage, it can take a longer period of time for a Wi-Fi network to come back up than for power and operation to resume at these types of smart devices. In this event, we didn't want the user to be required to reconnect each of their devices when in reality if the devices were to attempt to connect at a slightly later point the devices would be successful in

their attempts to connect to the network. The figure below shows how the system behaved when there was an unexpected loss of power.

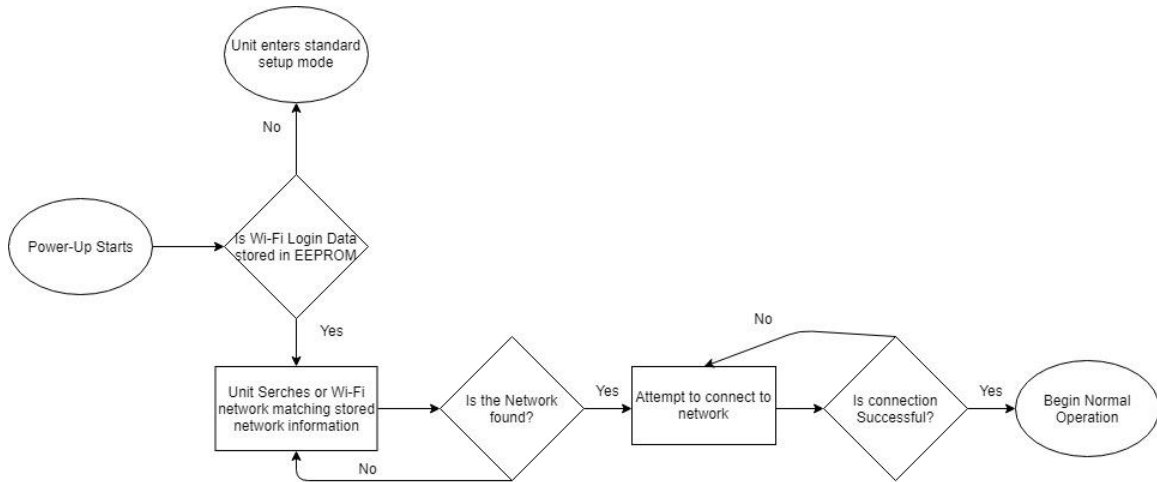

Figure 11: Power Recovery Flowchart

## 7.5 PUM Time Slot Method

In order for the both the control unit and the main server to effectively monitor power we needed to discretize the power usage measurements to accommodate for the physical performance constraints of the control unit, the main server and the network on which they communicate. To accomplish this, we broke up power measurement reading cycles in a manner analogous to TDMA communication. Each measurement cycle is directly linked with a time slot. Before the control unit can begin measuring power, it must synchronize its time with the main server. Once synchronized the control unit waits for the next time slot then begins recording. The control unit records the average power consumption during a time slot and adds the reading and corresponding time slot id to the power reading buffer. Power reading – time slot pairs are periodically sent from the buffer to the main server. Time slot size must be selected based on the physical constraints of both the control unit, the main server and the medium which connects them. Selecting a time slot that is too small would lead to buffer overflow of either the control unit's power reading buffer or the main server's power reading buffer. In addition, the large number of incoming power reading packets would require more expensive main server hardware. The biggest issue however, would be the resulting congestion of the user's network. Selecting a time slot that is too large would lead to overall inaccurate power measurements over long periods of time. Choosing the time slot is essentially an exercise in trade off analysis between power monitoring accuracy and congestion control. Power readings lost during

transmit mode are replaced with the average of the readings within the same time slot. The figure below shows the power usage measurement method.

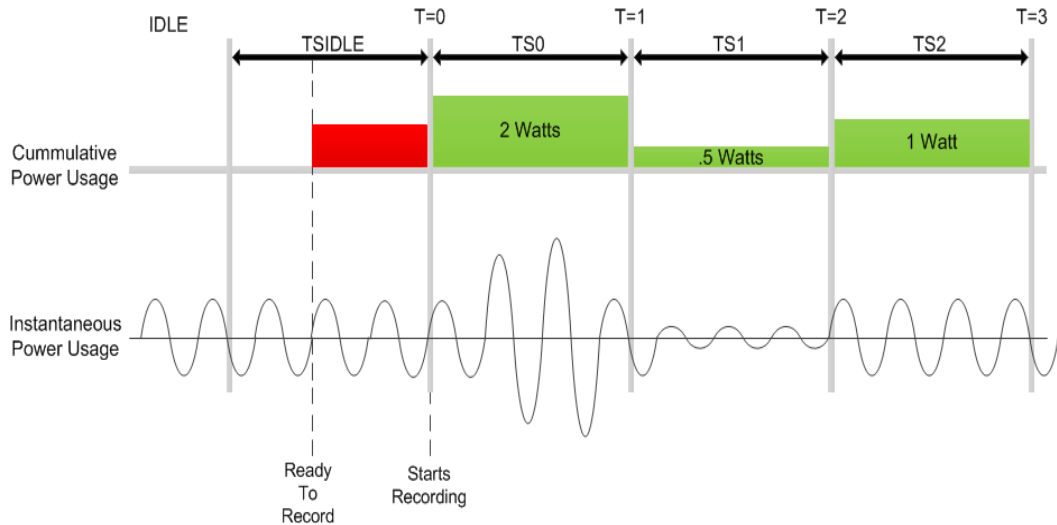

Figure 12: Power Usage Measurement Method

The below image demonstrates the transition from transmit mode to record mode and back which occurs every time slot on the power usage measurement module (PUMM) in the control unit. At the start of the time slot the power usage measurement module initiates a serial connection with the Wi-Fi module. Once a connection has been established the power usage measurement module transmits its most recent power usage readings to the Wi-Fi module. Once the power usage readings have been transferred, the power usage measurement module reads commands (if there are any) from the Wi-Fi module and adds them to the command buffer. For the rest of transmit mode the power usage measurement module attempts to address commands in the command buffer. At the end of the time slot the process repeats. During transmit mode some information is lost. To prevent inaccurate overall power usage readings the length of transmit mode is sufficiently limited. The figure below shows the transition from transmit mode to record mode.

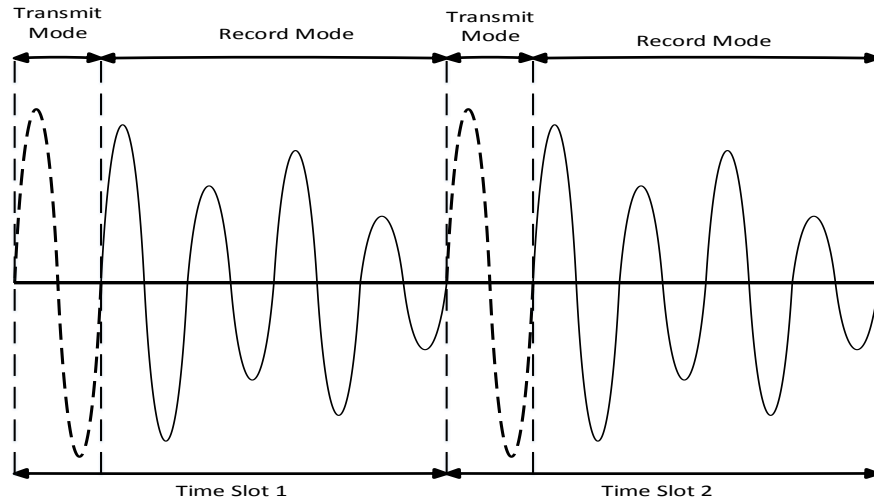

Figure 13: Transmit Mode to Record Mode Transition

## 7.6 Outlet Control Unit Prototype

For the initial outlet control unit prototype we decided to use a standard ABS plastic box as the housing. The power outlet is a standard 120 volt 15 amp AC wall outlet. The outlet control unit's power plug connects directly to the user's wall outlet. User devices are then connected to the outlet control unit's power outlet and their power usage is monitored by the power control unit. The outlet control unit has a bypass power switch which can manually connect/disconnect power from the entire control unit. The outlet control unit has a setup/connect mode (SCM) button which can change its current operating mode from setup mode to connect mode and vice versa. The figure below shows the prototype of the outlet control unit.

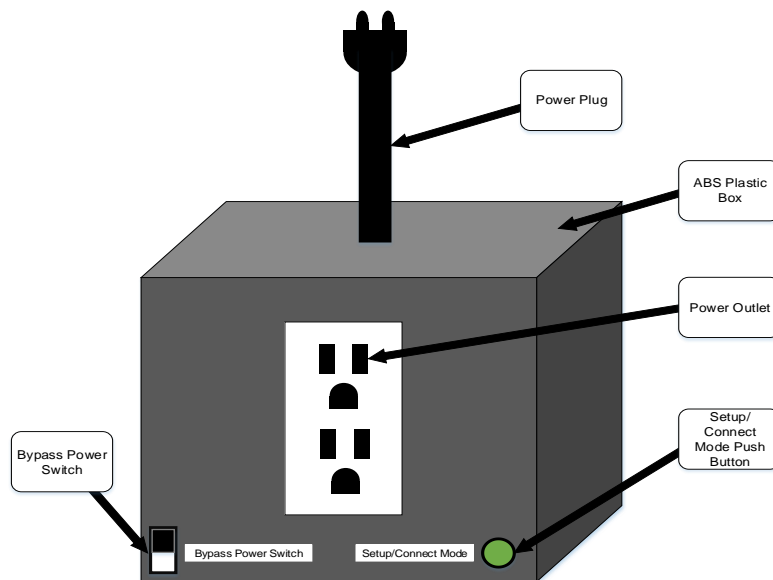

Figure 14: Outlet Control Unit Prototype

## 7.6.1 Final Outlet Control Unit

Much of the outlet control unit stayed the same. The primary difference between the prototype and the final is the construction method. The final outlet module was not put in an ABS plastic box. The final module was placed in a wood housing. Also the power plug was slightly different. The main power plug did go into the outlet module but also went into the power supply. This allowed for one power plug to power both the power supply and the outlet itself.

## 7.7 System Connection Map

The diagrams below illustrate the manner in which user devices connect to the outlet control unit. When booting in setup mode the control unit creates its own Wi-Fi network and initializes a configuration interface web server on that network. The user can then connect to the control unit's network using a Wi-Fi enabled device such as a phone, tablet or personal computer. The user can then use their devices browser to navigate to the IP address of the control unit's web server and modify its configuration settings. The control unit's configuration parameters can only be modified while in setup mode. The figure below shows the connection map for a control unit in setup mode.

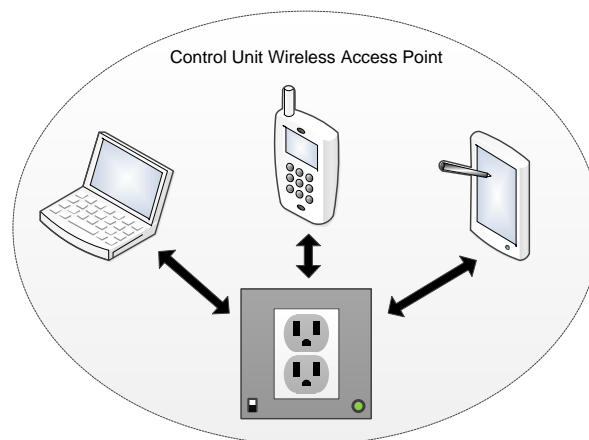

*Figure 15: Setup Mode*

Shown below is a figure which illustrates the manner in which the control unit connects to the main server when powering on in connect mode. Once the control unit connects to the user's Wi-Fi network it can then connect via the internet to the main server and begin receiving/sending data to and from it. The figure below shows the connection map for the control unit in connect mode.



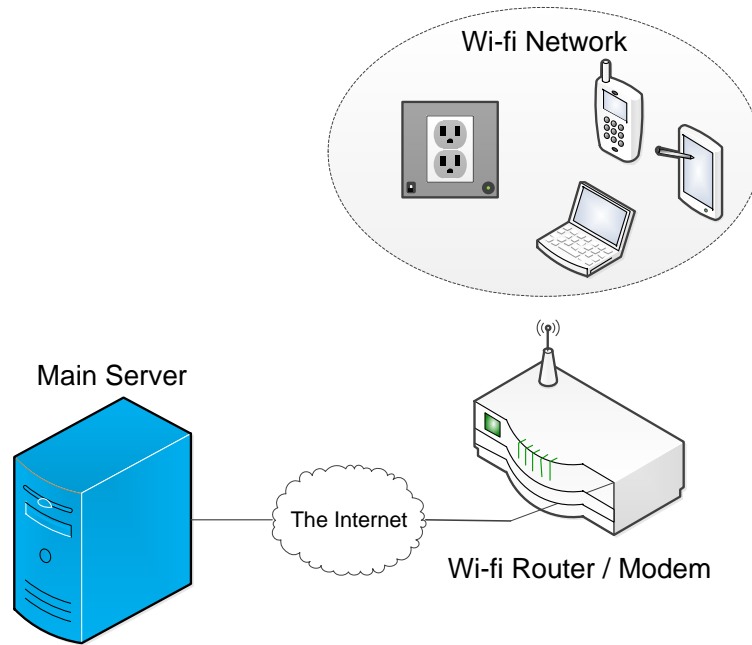

Figure 16: Connect Mode

## 7.8 Main Server / Client Interaction

The figure below shows the flow of data between the software entities of the system. The primary software entities of the main server consist of the NodeJS server, the MySQL database, the OS firewall and the server OS. The NodeJS server acts as the front end interface for control units and users alike. It serves the browser web interface to the user and records data from control units. In addition, it also relays commands set by the user to the control units. The OS firewall is responsible for filtering unwanted external network interactions. The rules which govern whether an interaction should be filtered are stored in the operating systems IP tables' structure and are modified by the NodeJS server and the administrator. The OS acts as a medium between the NodeJS server and internal entities such as the MySQL database and OS IP table. The OS Firewall in a sense acts as the medium between the NodeJS server and external entities such as control units and browser clients. The figure below shows the main server / client interaction diagram.

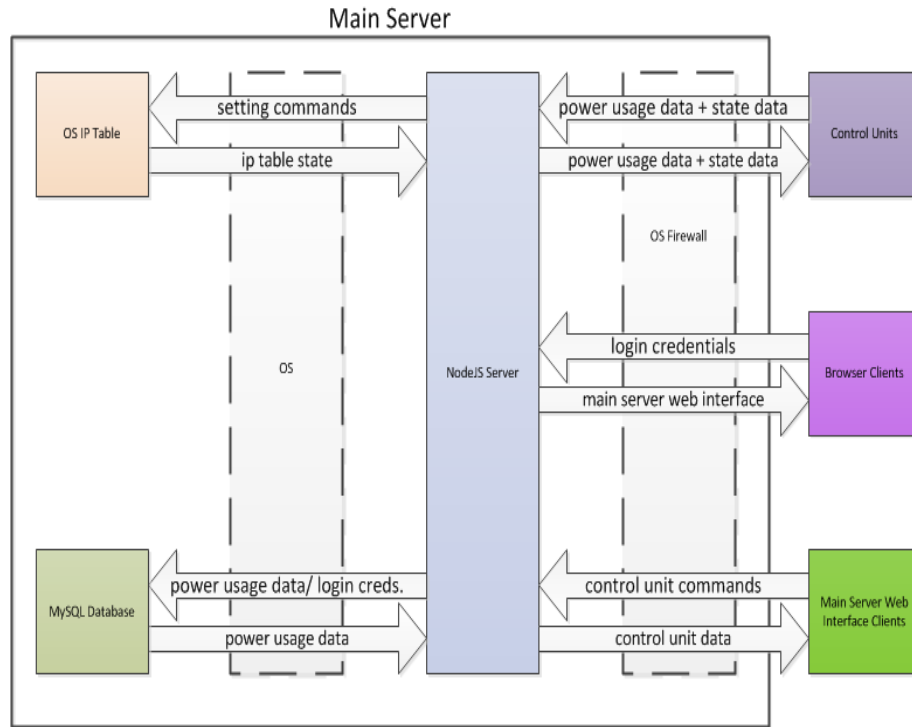

Figure 17: Main Server / Client Interaction Diagram

## 7.9 Microcontroller and Module Powering

Obtaining low DC voltages was critical for our project. Everything that modifies processes and transmits data operates at these low voltages. There are two voltages that were most important to obtain. These voltages are 5 volts and 3.3 volts. These voltages will power the microcontroller and the Wi-Fi module and their supporting components. To obtain these voltages, the rectified and lowered voltage from mains is sent through a series of filters and voltage regulators that gradually steps down the voltages to the critical voltages of 5 and 3.3 volts. The flow diagram below demonstrates this process.

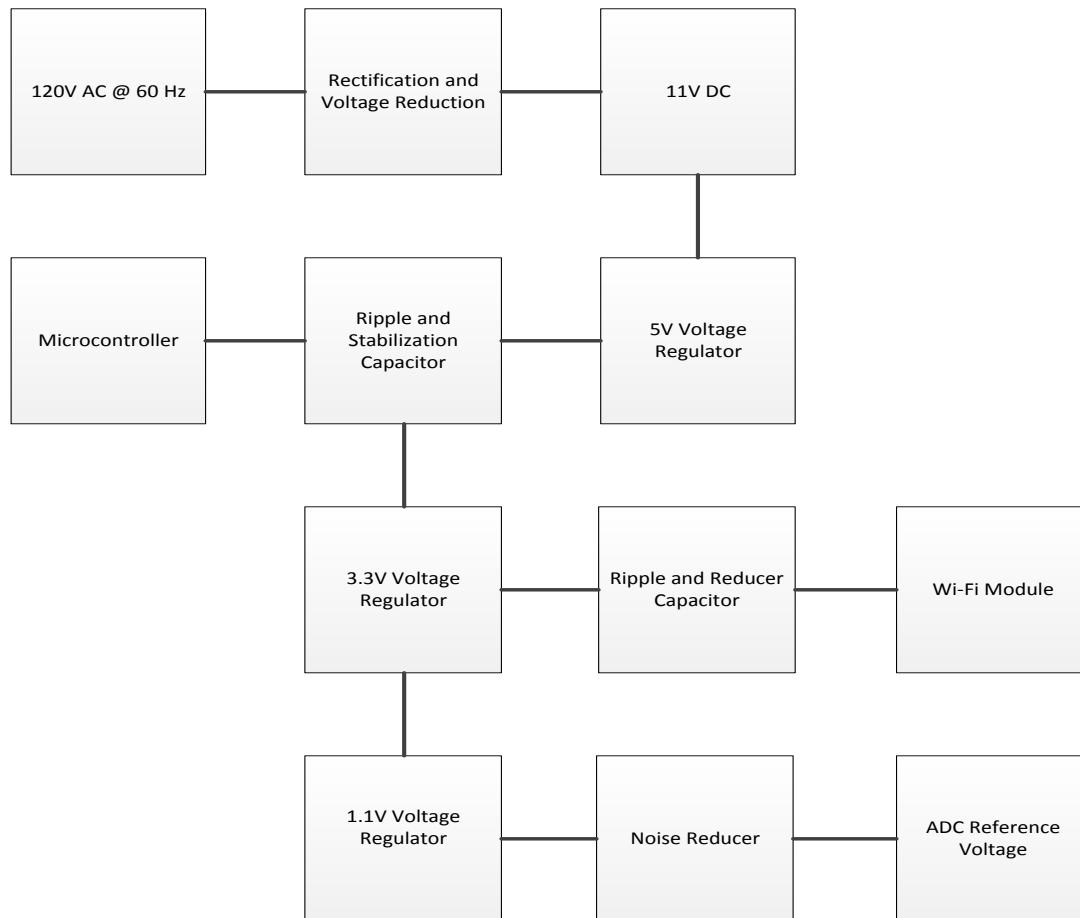

Figure 18: Microcontroller Powering Diagram

## 7.10 Microcontroller Connections Overview

The microcontroller was the most important module in the home energy project. While the sensors and attachments are critical for measuring and transmitting data, the microcontroller is the key element in processing all the data coming in and out. Because of this, it was important to have a clear overview of all connections that are connected to the microcontroller. These connections include power, data transmission and modules that collect live analog data. The figure below demonstrates and gives a high level overview of all components connected to the microcontroller.

It should be noted that the thermostat has two unique connections. This is because this microcontroller has more tasks to do than other modules that just monitor and transmit power usage. Because the thermostat must measure this power as well as display current temperature and set temperature, the thermostat has extra display and temperature measuring modules which can be seen below.

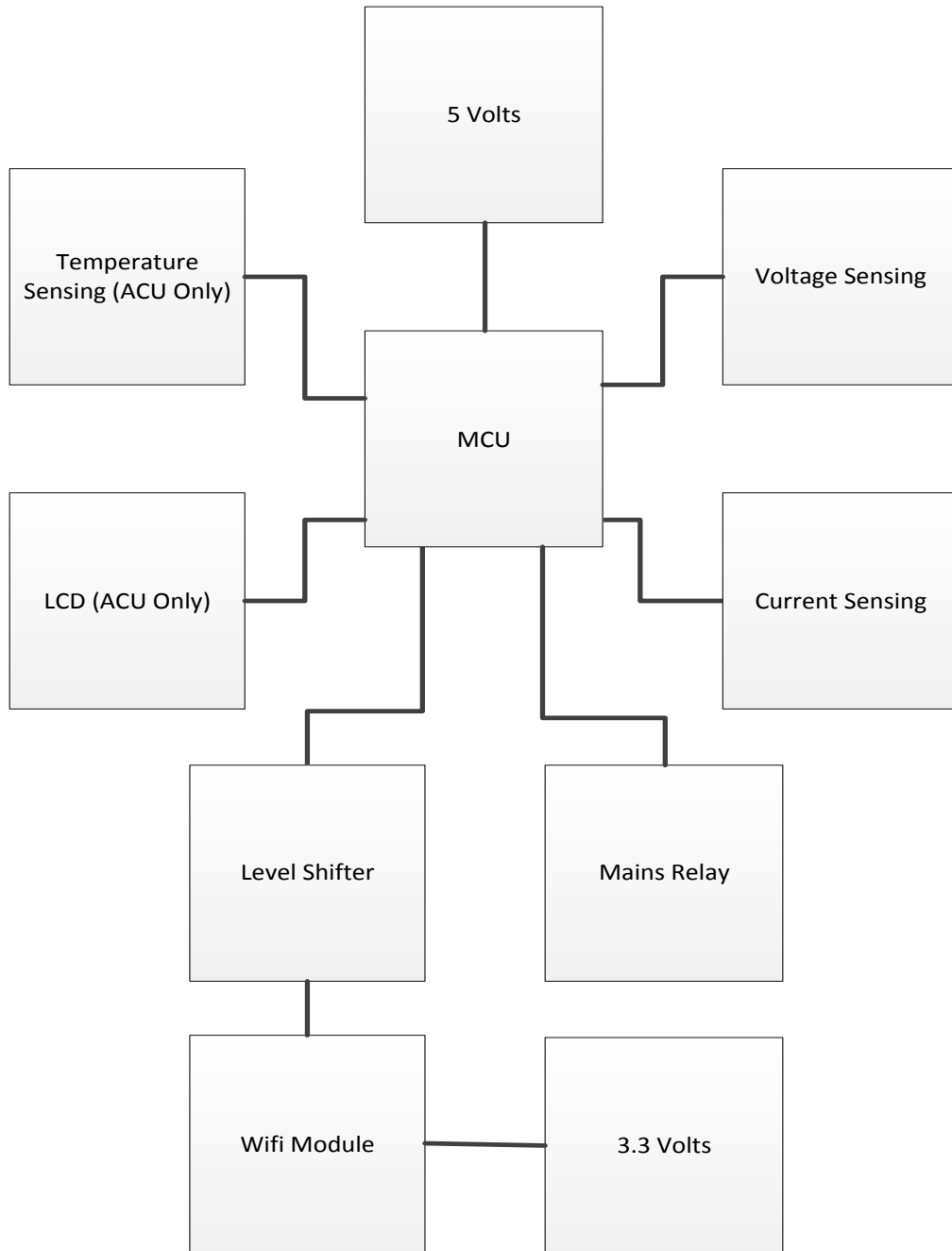

Figure 19: Microcontroller Connections

## 7.11 Time tracking on the Arduino

As our system needed to keep track with real world time, it was important to consider how we would do this. This was important because all of the power data being sent from the various components have a time signature along with them, to let the database know what time the power measurement corresponds to. This

value needed to be an exact minute time in order for the server to handle the data properly. The figure below shows how we accomplished this. When each device connects successfully connects to the network, they ping the database to retrieve the current time. This time value was converted from a 24-hour format to a single integer in the form of minutes. This value ranged from 0 to 1440, one minute for each minute of a 24-hour day. The 'millis()' function will assist us greatly in this endeavor. This function tracks the time in milliseconds since the Arduino has booted. Since we want to track when a minute passes we will check if the elapsed time since the last data transfer is 60,000 milliseconds. If so, we will send the data database along with the minute value that data corresponds to. We will then increment the data counter by one and start the process over again. Of course, before incrementing we will also need to check if the current minute value is equal to 1440, and if so then reset the minute timer to 0. The millis() function does not roll-over for 49 days meaning it should about a month and a half before any discrepancies, which will still be incredibly minor.

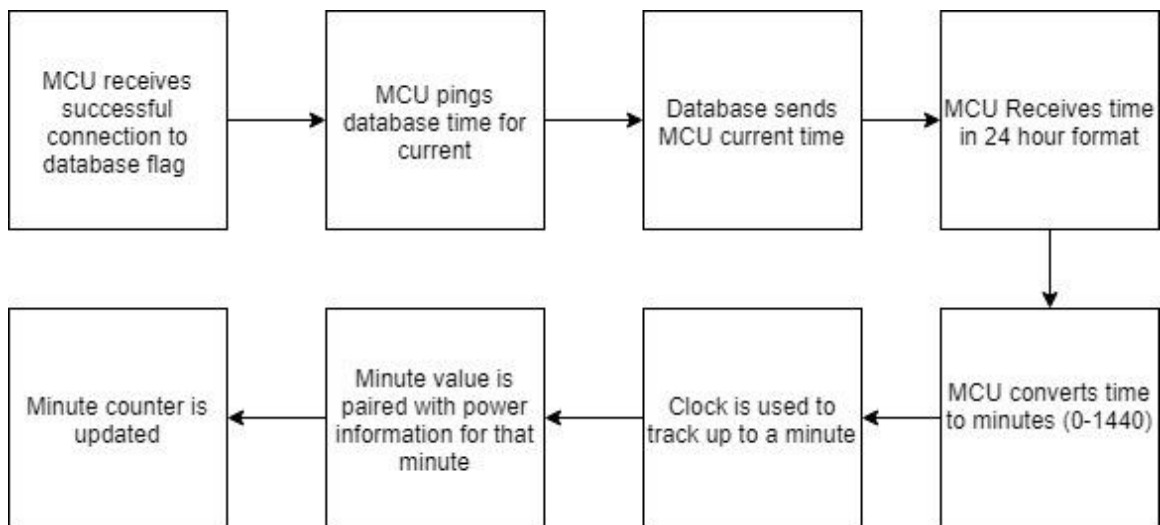

Figure 20: Minute Counter Flowchart

### 7.11.1 Final Time Tracking Implementation

In our final design we made a slight design change to simplify our time keeping process. Instead of getting a 24 hour time and converting it to a minute value between 0 and 1440, we instead use UNIX time. A unix time was requested from the server and on the next start of the minute the devices would begin recording and transmitting power data. This ensures that every time stamp the server receives is an exact minute value, which the server requires to operate. Using UNIX time was also very helpful as we were able to easily access this value and it is designed to be very accurate.

## 7.12 Unique Thermostat Considerations

The microcontroller was the core of the project. The microcontroller was the module that took in data, processed the data, and packaged data that was sent to the server. Because of this, it had many attachments and modules to assist it in this goal. The diagram below gives a high-level view of the devices connected to the microcontroller and the functions they serve. It should be noted that some attachments are unique to the thermostat only. The thermostat had special hardware because it has more functionality than the power sensor for the outlet and the light switch. The thermostat must measure the power from the air conditioning unit as the outlet and the light switch do. However, the thermostat must also control when the thermostat turns on the air conditioning unit, based on what the current temperature is and what the user has set the desired temperature to. Additionally, the thermostat must display the current temperature and the set temperature to the user. In total this means that the thermostat has 3 unique attachments that must be considered; the thermometer, the LCD and the buttons.

To allow the thermostat to monitor the current temperature, we utilized the DS18B20, which is a 1-Wire Digital Thermometer. The 1-wire design is incredibly advantageous for our design as it left other I/O pins to be freed up at the thermostat, which has the most unique attachments. From a programming standpoint the device was also incredibly easy to work with thanks to the availability of a couple libraries. The first of which assists in the 1-wire data flow, so the master/slave communication protocol didn't need to be handled by us. The other handles the conversion of the data read from the thermometer into standard units that we can then read. These are the OneWire and DallasTemperature libraries. This made the entire process of displaying the current temperature on the thermostat very simple. The figure below shows how the thermometer will be wired to the MCU. While this does demonstrate how simple the 1-Wire device makes the whole process, the greater take away is the 4.7K  $\Omega$  pull-up resistor that connects the data line to  $V_{CC}$ . This makes it so that the idle state of the bus is high.

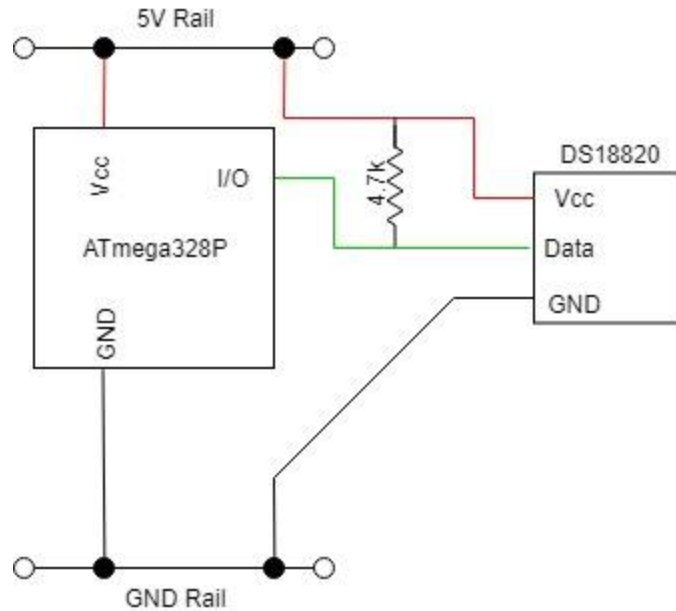

Figure 21: Thermometer Pin Configuration

Outside of the web interface, and to a certain degree the light switch, the air conditioning control unit was the other location the user was be able to control the system via the temperature up and down buttons. This changes the 'Set Temp' value displayed on the LCD at the unit. However, cooling and heating units often have minimum and maximum temperatures since, so we wanted to restrict the range of values we let our user set as their temperature. The figure below shows how we implemented this. When the user presses the 'Up' button on the control unit, we check if the current set temperature is 85 degrees, which is the max temperature we will allow. If it is, we present a message on the LCD saying, 'AT MAX TEMP'. If not, then we increment the Set temperature variable by 1 and then display the new set temperature on the LCD. Likewise, if the user presses the 'Down' button we check if the current set temperature is 65 degrees, which is our minimum temperature. If so we display a message on the LCD saying, 'AT MIN TEMP'. Otherwise we decrement the set temperature variable by 1 and update the LCD with the new set temperature. In both cases the new temperature value is also be sent to the A/C unit to change the temperature output accordingly.

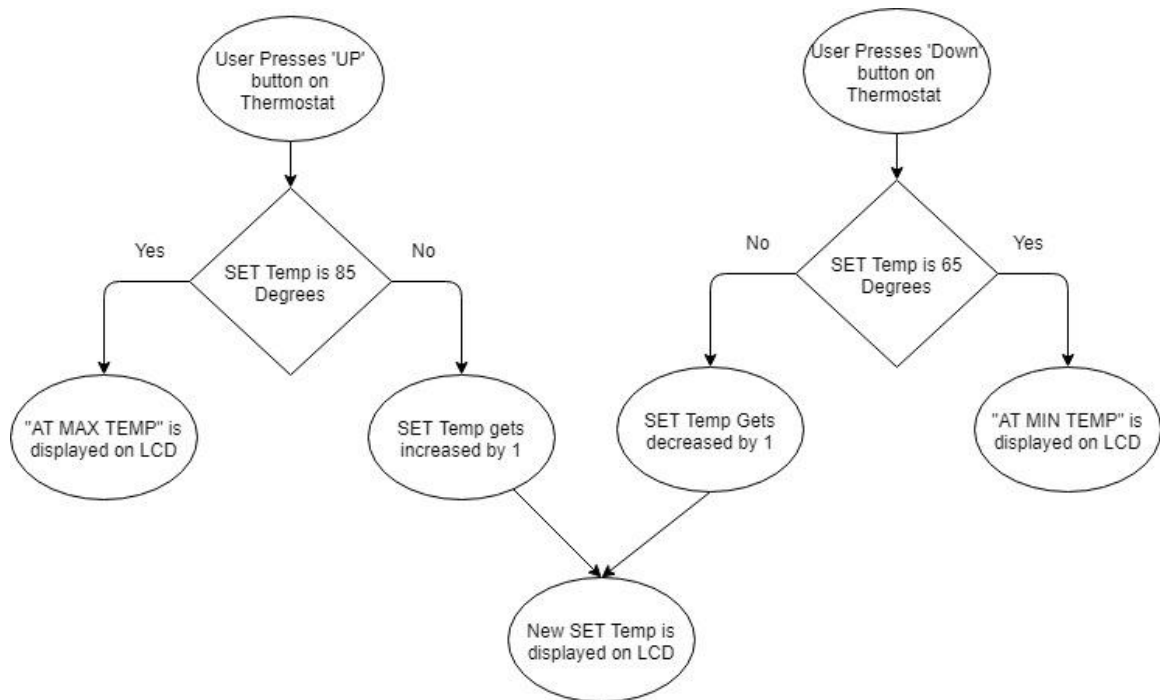

Figure 22: A/C Control Unit Flowchart

The last special consideration for the thermostat was something previously discussed in the constraints section. This was the inability for a real air-conditioning unit to be used in our final build of the project. Instead we be connecting a small electric fan to play the role of our air-conditioning unit. We will still be monitoring the power consumption of this fan as normal, and sending it to the database, but we manipulate it server side to make it more accurately reflect the power consumption that would be typical of a real air-conditioning unit. We also want to be able to demonstrate that our thermostat is responsive to user input. To do this we will compare the set temperature against the temperature being read by the thermometer. If the user has set the temperature on the thermostat lower than that off the temperature on the thermometer then the fan will turn on to replicate the air-conditioning unit cooling the house. Conversely, if the user sets the temperature on the thermostat above what the thermometer is reading the fan will simply turnoff. To make wiring simple we will use a basic 120V fan so we don't need to manipulate the signal in order to power the fan.

### 7.12.1 Final Thermostat Implementation

There were a couple slight changes to our final design of our thermostat. We no longer measure any power data at the thermostat. Instead, when the temperature is such that the heating or cooling is turned on we spoofed power data and send it to the server. This was done so that the values the server displays are more in line with what a user would encounter in a real world environment. We also did not implement the 'AT MAX TEMP' or 'AT MIN TEMP' LCD messages as they were largely unnecessary.



## 7.13 Microcontroller Power-Data Handling

The core of our project was based around power monitoring. As such, it was important to address how the analog data is processed on the microcontroller. There are multiple facets of the data processing, from how we are sampling to how we are handling the data on the microcontroller before sending it. The goal of the design was to use as little space on the MCU while getting the most accurate measurements possible.

When reading any analog signal, it is important to consider how often to sample the signal. Sampling too infrequently can easily cause inaccuracies, while oversampling can increase power consumption and reduce the processing power that is available for other tasks. The figure below shows the difference between a low sampling rate and a high sampling rate. The low sampling rate appears to just be a random set of values, where the higher sampling rate clearly paints the picture of the signal it is meant to represent.

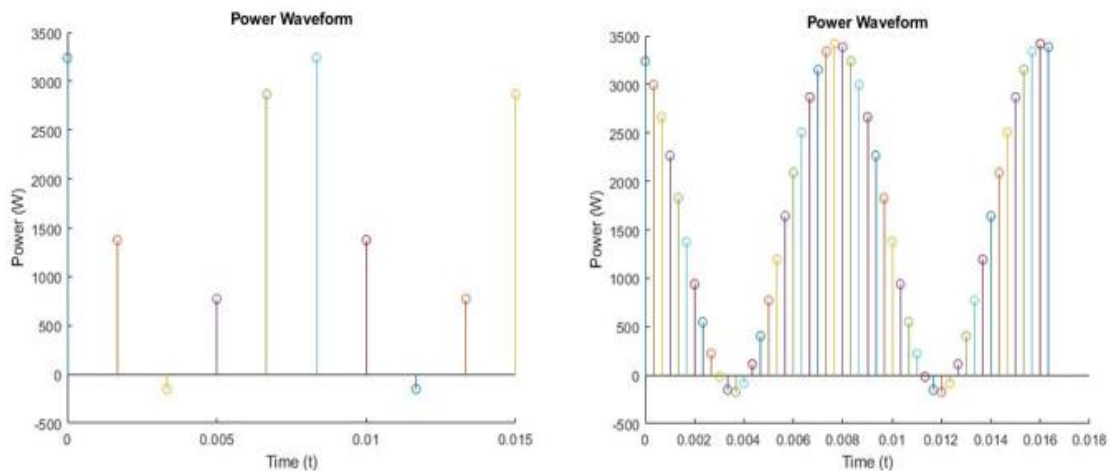

Figure 23: Sample Rate Comparison Visualization

Despite what the image above may lead some to believe, the lower sample rate may be perfectly sufficient. The table below shows a comparison of the two signals measured above. The exact same signal was measured both at 10 samples per second and 50 samples per second, and while you would expect the 50 samples per second measurement to be more accurate this was not the case. When the data points in each graph were averaged the results were the same. These results also both matched the expected calculated power value for the signal. While this was a simulation, so we will see some discrepancy, this shows us that 10 samples per cycle was adequate for our needs.

Table 22: Sample Rate Comparison Table

	<b>10 Samples/Cycle</b>	<b>50 Samples/Cycle</b>
<b>Voltage</b>	120 V	120 V
<b>Current</b>	15 A	15 A
<b>Frequency</b>	60 Hz	60 Hz
<b>Power Factor</b>	0.9 (Lagging)	0.9 (Lagging)
<b>Calculated Power</b>	1.62 kW	1.62 kW
<b>Measured Power</b>	1.62 kW	1.62 kW

It was also important to address how we will get the microcontroller to sample at our desired sample rate. This was accomplished with the `millis()` function and the `analogRead()` function. Since we are sampling a 60 Hz signal, we had to have sampled one complete cycle every 0.016667 seconds. To get 10 samples per cycle this required us to get a sample once every 1.6667 milliseconds. Since we could not use decimal values with the `millis()` function we instead sampled once every one millisecond. Every time our `millis()` value increments we will perform an `analogRead()` on the ADC pin to get the current value. This will put at 16 samples per cycle. It was also important to remember at each device we will be performing an analog read on three different pins, one for voltage and two different current measurements.

Of course, reading the data was only part of the process. Once we had the values from the values from the ADC we needed to manipulate them to get them in a format that can be easily sent to the server. The figure below shows how the data was to be handled after being read from the ADC. Each time we took a sample we are taking a sample of the current and the voltage. However, we were not be reading the actual values of these, but rather a scaled value that ranges from 0V to 5V. This was due to the limitations of the MCU. In order descale the value we instead multiply the read current and voltage values by a fixed scalar. To maximize the accuracy of our readings we will need to calibrate this value at each of the device as even the most minor difference in resistance due to the manufacturing process is enough to cause inaccuracies. After both the current and voltage values have been descaled they were multiplied together to get the instantaneous power at the time of the sample. This instantaneous power was then added to a sum of all the power readings since the start of the last interval. We are using one minute as our interval, as this was the highest resolution we will show to our users on the database. After a minute has passed the sum of all the powers, now being the total power used over the course of the minute will be sent over the Wi-Fi network along with the 24-hour minute value.

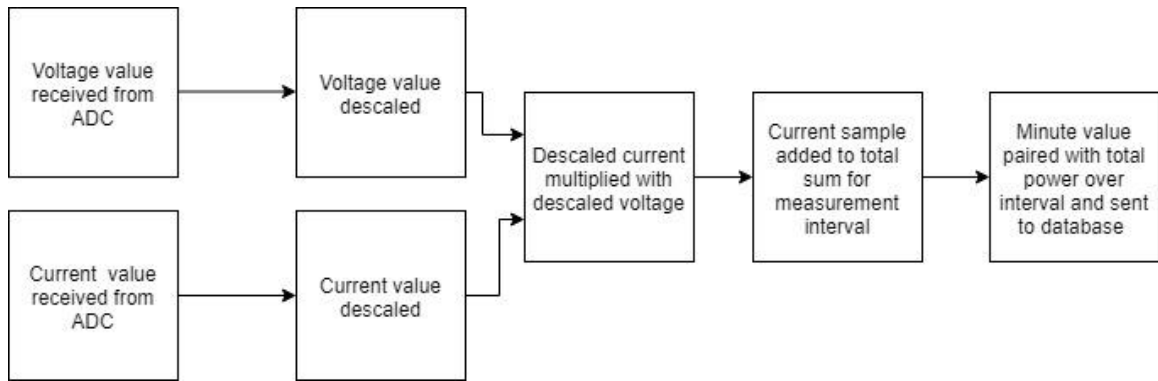

Figure 24: Power Data Handling Flowchart

The main advantage to using this method was the minimal storage space required on the MCU. By not storing individual power values outside of the most recently read one we greatly reduced the amount of data being stored on the MCU. This freed up more memory, allowing us to comfortably fit all of the code and data on the MCU. This was especially important for the thermostat, which required additional code to handle the LCD controls along with the temperature readings.

There was an added issue regarding reading current values that must also be addressed. Due to the range of signals that needed to be read by the ADC there must be two separate amplifiers with outputs to the ADC pins. This was because there are situations where the lower gain amplifier won't produce a signal with enough variance for the ADC to be able to read it accurately. For this reason, another amplifier with additional gain was added with its output also going to an ADC pin. The problem was such that sometimes this will produce a signal with too high voltage and the output hits the rail of the amplifier, causing clipping in the reading. To solve this problem some simple logic was implemented in the microcontroller code in to select which amplifier we read the output of. The flow chart for this logic can be seen in the figure below. The value at the pin of the amplifier with higher gain was read first. If this value was above 4.8V, then we are in danger of clipping our signal and should read from the lower gain amplifier which had its own function to descale the value, so it can be properly manipulated. Conversely, if the value read at the high gain amplifier pin was below 4.8 volts then we know the extra amplification is important and clipping is not an issue, so we can use the function created to descale those readings before they are manipulated.

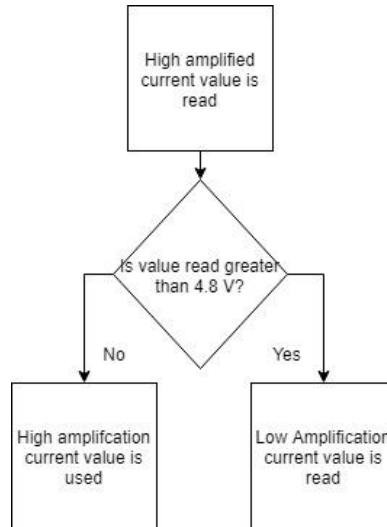

Figure 25: Current ADC Pin Selection Flowchart

### 7.13.1 Final Microcontroller Power-Data Implementation

We made some minor changes to how our sampling methodology operates in the final design of our project. Instead of frequent samples we instead did periodic high-resolution samples. Every second we would spend 16 milliseconds sampling as fast as possible and then calculate our values based on this, assuming the power would be consistent for the second. This gave us more to handle other tasks at the MCU as the time spent sampling was greatly reduced.

### 7.14 MCU Relay Communication

Along with the various power monitoring ability of our system we also allowed the user to remotely control each of the devices in the system via the web interface. This consisted of sending a signal from the server to the MCU, which then interpreted the signal to either turn the device on or off. To perform the controlling of the device we connected a digital output of the microcontroller to a mechanical relay that will switch the on/off state of the device. This can be seen in the figure below. Here, we had the digital output of the microcontroller connected to the base of a BJT transistor. This allowed the microcontroller to output enough current to power the inductor that is controlling the switch in the relay. Since we are using an inductive relay we must also incorporate a fly back diode into our design, to protect our circuit when we witness an abrupt voltage change across the inductor caused by reducing the current. When the user wants to supply power to the load, be it the light bulb, air-conditioning unit or device connected to the outlet via the web interface the MCU will retrieve this signal and set the output to high. This will output current to the inductor thus closing the mechanical

switch and allowing current to flow to the load. Inversely, if the user wants to turn any of the devices off remotely the output pin will go to low, no current will flow to the inductor in the relay and the switch will open preventing any current from flowing to the load.

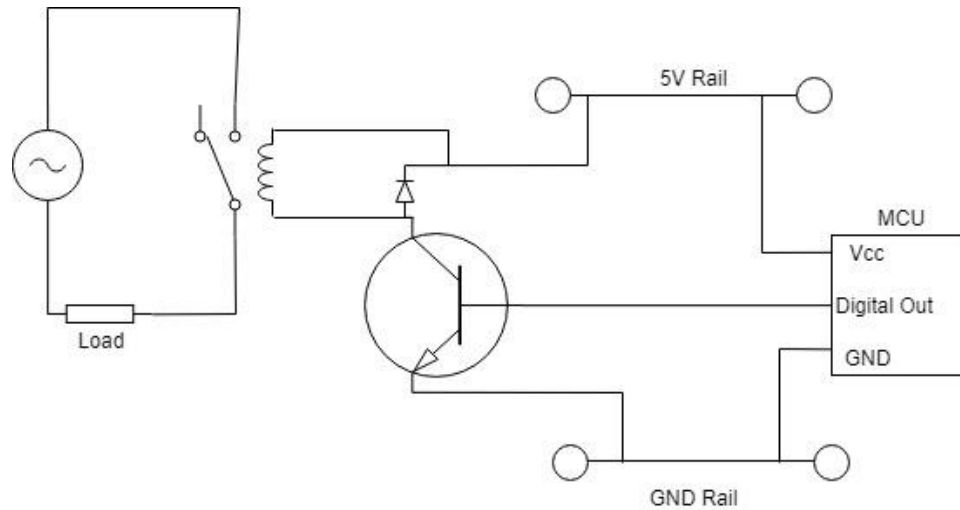

Figure 26: Relay Control Diagram

### 7.14.1 Final Relay Implementation

In our final project we implemented relays in a very different manner. Our original attempt at using a mechanical relay introduced numerous electrical problems that we hadn't predicated, which caused our MCU to reset. To circumvent these issues, we instead used a solid-state relay. This solved our electrical issues with regards to the mechanical relay, however there was a voltage drop introduced across the solid-state relay which made our power measurements slightly inaccurate.

### 7.15 Current Sensing Design Details

The main goal of this project was the ability to accurately measure the power a device is using and in order to do that, accurate current measurement was a requirement. The method to do this is to measure the voltage across a shunt resistor with a known resistance. The voltage across this shunt is a very small sine wave centered at zero. At max load of 15 amps the voltage is only 1 mV peak. This voltage needs to be shifted and amplified into a range of 0 to 5 volts, at max load. This can be done in two different ways. The first way is by first shifting the wave up and then amplifying it. Using this method would result in not needing any negative voltages to power the operational amplifier since the sine

wave will be shifted above 0 volts. The second method requires a negative voltage to power the operational amplifier because the sine wave would be amplified first and then shifted up to be centered at 2.5 volts, the mid-point from 0 to 5 volts.

The ideal voltage range at max load of 15 amps is to be 0 to 5 volts. Achieving this can be difficult when shifting the wave first and then amplifying it. This is because the operational amplifier can only output to a certain voltage from the power rails. For example if the operational amplifier is powered with +5 volts on the positive rail and 0 volts on the negative rail, the maximum output from the operational amplifier may only be 4.5 volts, while the minimum may only be 0.5 volts. Because of this reduced voltage range there will be a reduction in accuracy. It is possible to lower the maximum voltage that the analog to digital converter will read, increasing the accuracy, however it is not possible to raise the minimum voltage. This means that the 0 to 0.5 volt range that is lost because of the operational amplifier will be lost in accuracy. Because of this reason it was desired to amplify the signal first and then shift it up into a range of 0 to 5 volts. The figure below shows the circuit which includes the shunt, the amplifying stage, and the level shifter.

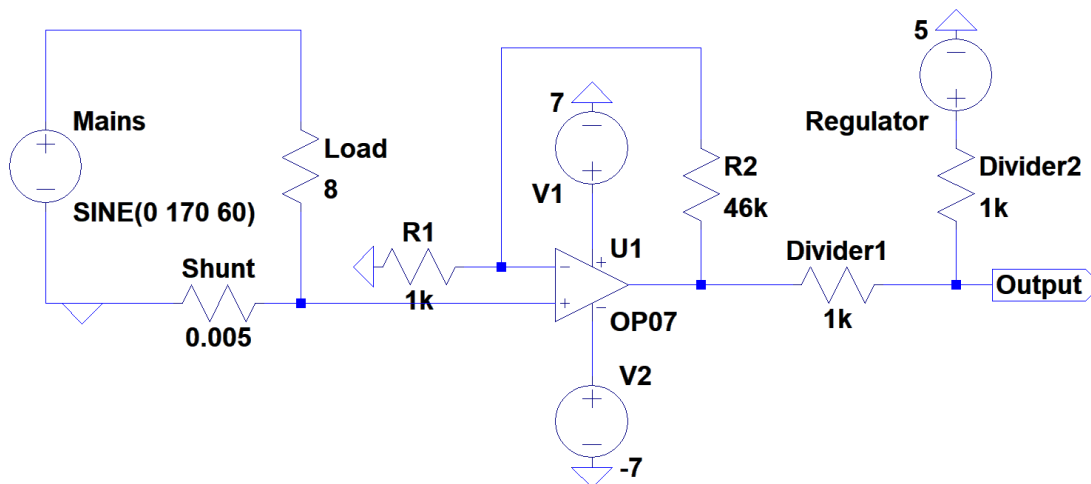

Figure 27: Shunt Current Sensing Circuit

The figure shows that the voltage across the shunt resistor goes into a non-inverting amplifier with a gain of 47. The gain was chosen by first finding what the maximum voltage across the shunt would be. When 15 amps flows through a 5 mΩ resistor the peak voltage will be 106 mV. Before the level shifting it is desired to have a maximum peak sine wave of +/- 5 volts. The gain of the amplifier was then found by dividing 5 volts, the ideal peak output voltage, by 106 mV, the maximum input voltage, which results in a gain of 47. Now that the signal is in a range of -5 to +5 volts it is desired to shift that waveform up into a range of 0 to 5 volts. This was done by using two resistors of equal value to create a voltage divider. When 5 volts is placed at the other end of the voltage divider so the waveform gets shifted up. This is seen by using super position. When the input

waveform is zero the output is half the 5 volt supply voltage, which is 2.5 volts. When the input waveform is at 5 volts the output will be half the input voltage, or 2.5 volts, plus half the 5 volt supply voltage, which is 2.5 volts. This results in a 5 volt output. Finally, when the input waveform is at -5 volts the output will be at -2.5 volts, plus half the 5 volt supply voltage, or 2.5 volts, resulting in an output of 0 volts. Now very high accuracy will be achieved for high current, however when there is a small current flowing through the load the output waveform will be very small and not very accurate. This is why a second stage amplifier was added, which was designed in the next section.

### 7.15.1 Current Sensing Second Stage Amplifier

The second stage amplifier was implemented in order to increase the accuracy when reading low currents. The output of the first amplifier is design to output 0 to 5 volts when the max load of 15 amps is flowing through the shunt. As the current decreases the range of the output significantly decreases. When 1 amp is flowing through the shunt there is only a range of 0.33 volts on the output. If an even smaller current flows through the shunt then the analog to digital converter will not be able distinguish the waveform. Because of this it was decided that the output of the second stage of the amplifier will produce a voltage of 0 to 5 volts when 1 amp is flowing through the shunt resistor. The figure below shows the circuit of the two stage amplifier.

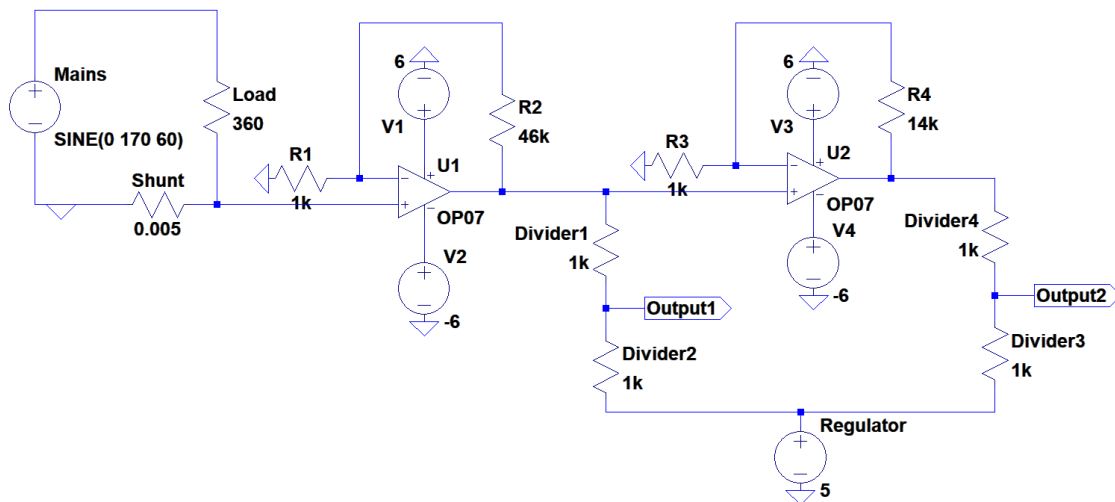

Figure 28: Current Sensing Second Stage Amplifier Circuit

The figure shows that the design of the second stage amplifier is exactly the same as the design of the first stage amplifier, but with different resistor values to achieve a different gain. When 1 amp is flowing through the shunt the voltage at the output of first amplifier, before level shifting, is at 332 mV peak. The desired output of the second stage amplifier is 5 volt peak. In order to achieve this the

gain was found to be 5 volts divided by 0.332 volts, which is 15. This was the gain of the second amplifier. Now to turn this -5 to +5 volt wave into a 0 to 5 volt wave the exact same method of using a voltage divider was used. With this design it is seen that in the range of greater than 1 amp to 15 amps, the reading from the first amplifier is to be taken. When the load pulls less than 1 amp the reading from the second stage amplifier is to be taken.

## 7.15.2 Final Current Sensing Design Details

Only one aspect of the original design for the current sensing was changed, and that was the level shifting. Theoretically using a 5V supply for the voltage divider would shift the waveform to be centered exactly at 2.5V, however there are inaccuracies with this method. If the supply voltage is not a constant 5V, or the resistor values are not exactly the same, then the waveform will not be perfectly centered at 2.5V. To solve this a unity gain with a potentiometer was used in order to vary the supply voltage. This method allows for fine tuning so that the waveform can be centered exactly at 2.5V. The figure below shows the final schematic for the current sensing.

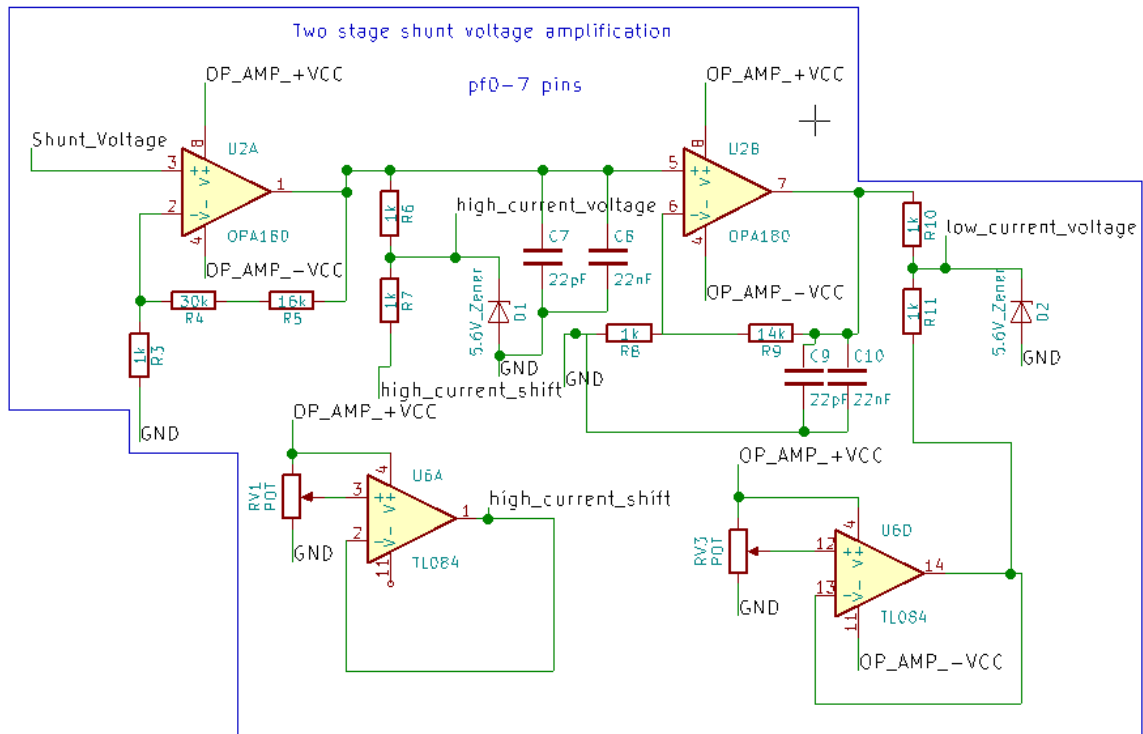

Figure 29: Final Current Sensing Schematic



## 7.16 Voltage Sensing Design Details

The main goal of the project was to accurately measure power, and in order to do that accurate measurements of current and voltage needed to be made. To step down the voltage and shift it into a range of 0 to 5 volts, so that the analog to digital converter can read it, two voltage dividers and an operational amplifier were used. The purpose of the first voltage divider was to step down the voltage from 170 peak to 5 volt peak. This stepped down voltage goes to an operational amplifier with a gain of 1 in order to protect the analog to digital converter in case of a rise in voltage. The operational amplifier protects the device because the output of the operational amplifier will never go above the voltage that is powering it. The output of the operational amplifier then goes to another voltage divider. The figure below shows the schematic.

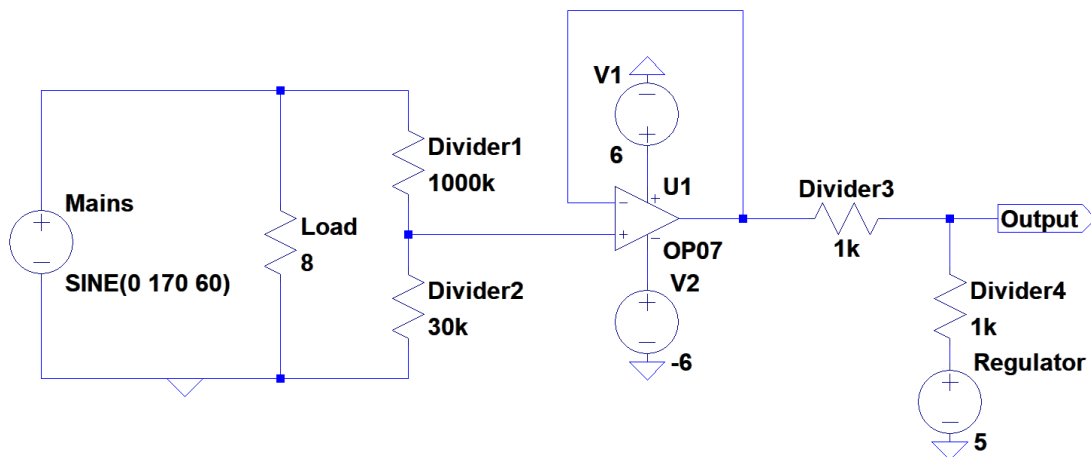

Figure 30: Voltage Sensor Circuit

Using the voltage divider equation with an output voltage of 5 volts and an input voltage of 170 volts, it was found that the resistor values needed were 1 M $\Omega$  and 30 k $\Omega$ . The resistor values of the second voltage divider, for level shifting, were found in the same way as for the current sensor. Resistors of equal value will result in an output of half the input plus half the 5 volt source. This results in a sine wave centered at 2.5 volts with peaks at 0 and 5 volts.

### 7.16.1 Final Voltage Sensing Design Details

The original design for the voltage sensing had some changes. The first change was a change in resistor values. Initially it was chosen to use a 1 M $\Omega$  and 30 k $\Omega$  resistor in order to scale down the 170V sine wave down to a 5V sine wave. However that gives no room for the mains voltage to fluctuate. It is very normal for mains voltage to vary anywhere from 115V to 125V. In order to give some

more room for fluctuations it was decided to use a 24 kΩ resistor instead of the original 30 kΩ. The second change that the voltage sensing underwent was the inclusion of a varying supply voltage. Just like for the current sensing, the voltage waveform of the voltage sensing was not able to be centered exactly at 2.5V from a 5V supply. This is why a unity gain with a potentiometer was used in order to fine tune the waveform to be centered exactly at 2.5V. The figure below shows the final schematic of the voltage sensor.

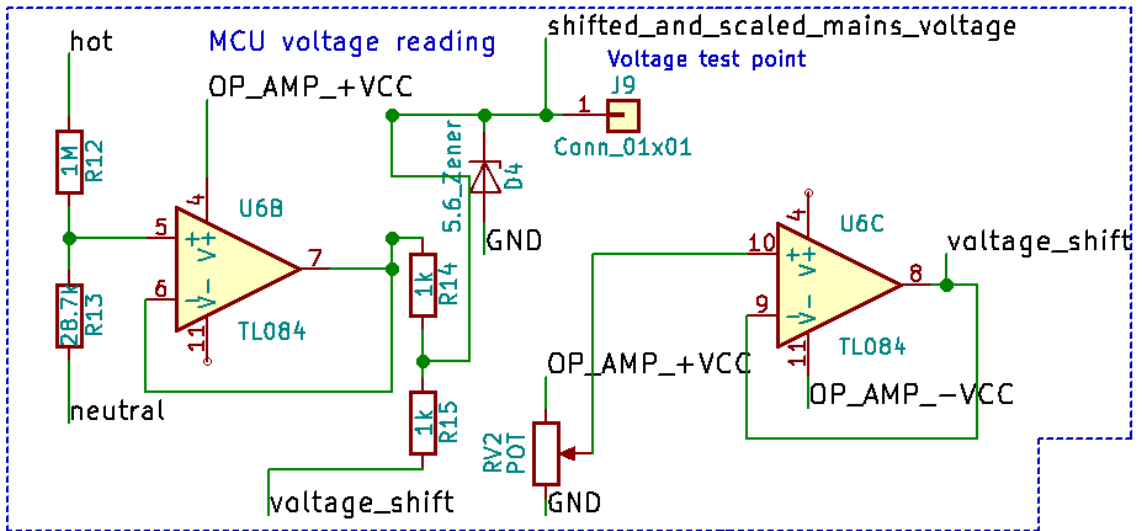

Figure 31: Final Voltage Sensor Schematic

## 8.0 Roles and Responsibilities

Project responsibilities of team members were set as shown below. The two computer engineers in our group Jonathan Killeen and Adam Althar were given primarily software related tasks. The two electrical engineers in our group Charles Desowitz and Anders Hauge were assigned primarily hardware related tasks. Critical project milestones include: initial outlet control unit prototype, main server prototype, switch control unit prototype, ac control unit prototype, control unit PCB implementations, final product assembly. The table below shows the roles and responsibilities of each group member.

Table 23: Role and Responsibilities

Component	Status	Assigned Team Member
CU Setup Mode Module	prototyping	Killeen
CU Connect Mode Module	prototyping	Killeen
CU Temperature Measuring Module	prototyping	Althar
CU Switch Controller Module	prototyping	Althar
CU Time Tracking Module	prototyping	Althar
CU LCD Controller	prototyping	Althar
CU Power Measuring Module	prototyping	Althar
CU Wi-Fi Main Server Communication Module	prototyping	Killeen
CU Web Server Module	prototyping	Killeen
CU Connect/Setup Push Button Event Handler	prototyping	Althar
CU Power Measurement Storage module	prototyping	Althar
CU Wi-Fi access point module	prototyping	Killeen
Main Server Web Browser Interface Handler	prototyping	Killeen
Main Server Control Unit Handler	prototyping	Killeen
Main Server IP Tables Interface Module	prototyping	Killeen
Main Server MySQL Database Interface	prototyping	Killeen
Main Server MySQL Database	prototyping	Killeen
Main Server Web Interface Design	prototyping	Killeen
Control Unit Web Interface Design	prototyping	Killeen
CU Power Supply Design	prototyping	Desowitz
CU Power Measurement Sensor	prototyping	Hauge
CU Temperature Measurement Sensor	prototyping	Desowitz
CU LCD Screen	prototyping	Althar
Outlet CU PCB Design	prototyping	Desowitz/Hauge
AC CU PCB Design	prototyping	Desowitz/Hauge
Switch CU PCB Design	prototyping	Desowitz/Hauge
CU Enclosure Design	prototyping	Hauge
CU Hardware Integration	prototyping	Desowitz
CU Software Integration	prototyping	Killeen

## 9.0 Project Prototype Construction

Prototyping during the project design stage was a very important step towards having a successful project. Prototyping allowed for proof of concept testing for different techniques that the members of the team may not have initially been familiar with and need to experiment some before the idea is committed to. The use of breakout boards and the like also gave the group the chance to become familiar with the technologies they would eventually be working with without the needed of a customized PCB. The following sections explain some of the prototyping that was done during the design phase of this project. Often times the components use are slightly different than those that we decided to use during the final build of the project but are representative of the types of sub-systems we eventually implemented and taught the members valuable skills that helped when the time to create the final system arrived.

### 9.1 Part Acquisition and Bill of Materials

The table below is a comprehensive list of materials required for creating the prototype and the final product. Excess parts were ordered for those which played critical role in the system. Unit prices were not included as electronics prices fluctuate frequently.

*Table 24: Bill of Materials of Key Components*

<b>Component</b>	<b>Quantity</b>
ESP 8266 ESP-01S Wi-Fi Module	10
ATmega2560	8
Operational Amplifier	3
Instrumentation Amplifier	5
TL084 Operational Amplifier	10
INA828 Instrumentation Amplifier	10
LM431 Zener Shunt Regulator	4
BSS 138 FET	14
DS18B20 1-Wire Digital Temperature Sensor	8
Assorted Electrolytic Capacitor Pack	1
Assorted 0.25 Watt Resistor Pack	1
16 MHz Crystal Oscillator	10
Assorted Tantalum Capacitor Pack	1
3.3V Regulator	14
5V Regulator	14
5mm LED Multiple Colors	20
RGB LED Push Button	4
MSR3 5 Million Ohm Shunt Resistor	20
Crystalfontz CFAH1602B-TMI-JT LCD Screen	2

These are less significant components than the previous ones. They are less expensive and are likely to take less time shipping than the components in the previous table.

Table 25: Bill of Materials of Accessory Components

Component	Quantity
2 mm Pitch Break Away Headers	30
2 mm Male to Male Jumper Wires	30
2.54 mm Pitch Break Away Headers	30
2.54 mm Male to Male Jumper Wires	30
2.54 mm Male to Female Jumper Wires	30
20-29 AWG Compatible Breadboard	4
Lead Free Soldering Spool	1
22 AWG Solid Core Wire Spool	1
Lead Free Soldering Paste	1
Solder Flux Pens	5
01C SMD 10K Ohm Resistor	28
Fine Paint Brush Set	1
Arduino Uno Board	4
USB A/B Cable	4
Desoldering Braid	1
Needle Soldering Tip	1
Chisel Soldering Tip	1
6mm Tactile Push Button	20
Through Hole Alligator Clips Pack	1

## 9.2 Equipment and Facilities

Table 26 shows a list of equipment needed for the project and the facilities which offer the equipment. Rows with "Group Owned" represent equipment items which are owned by one or more team members and do not require the use of a facility. Items with a facility listed as "Need to Purchase" are items not currently offered by accessible facilities and not currently owned by any group members.

Table 26: Facilities Used

Device	Facility
Contact Soldering Station	Group Owned
Multimeter	Group Owned
Oscilloscope	UCF TI Lab
Variable Power Supply	UCF TI Lab
Hot Air Soldering Station	Need To Purchase
Computer	Group Owned
Dremel	Group Owned

## 9.3 LCD Temperature Prototyping

The purpose of this prototype was to write variable information to the LCD in the form of temperature and test using 4-wire protocol to transmit the data to the LCD. The figure below shows this prototype. Of course, there are some differences between this prototype and how it was eventually to be executed in our final build. First the most obvious is this was using an Arduino development board as opposed to an on PCB MCU. Additionally, instead of a thermometer like we ended up using in the final build, a thermistor was used. The key takeaways from this were processing temperature from an analog input and getting familiar with the 4-wire transmission strategy. Even though a thermistor was used the 1-wire thermometer was still very similar in behavior, so learning to interpret the data was good practice. Likewise, the LCD writing was almost identical, so learning the functions that are helpful to write, along with how to space the unit at the end of the temperature regardless of the number of digits.

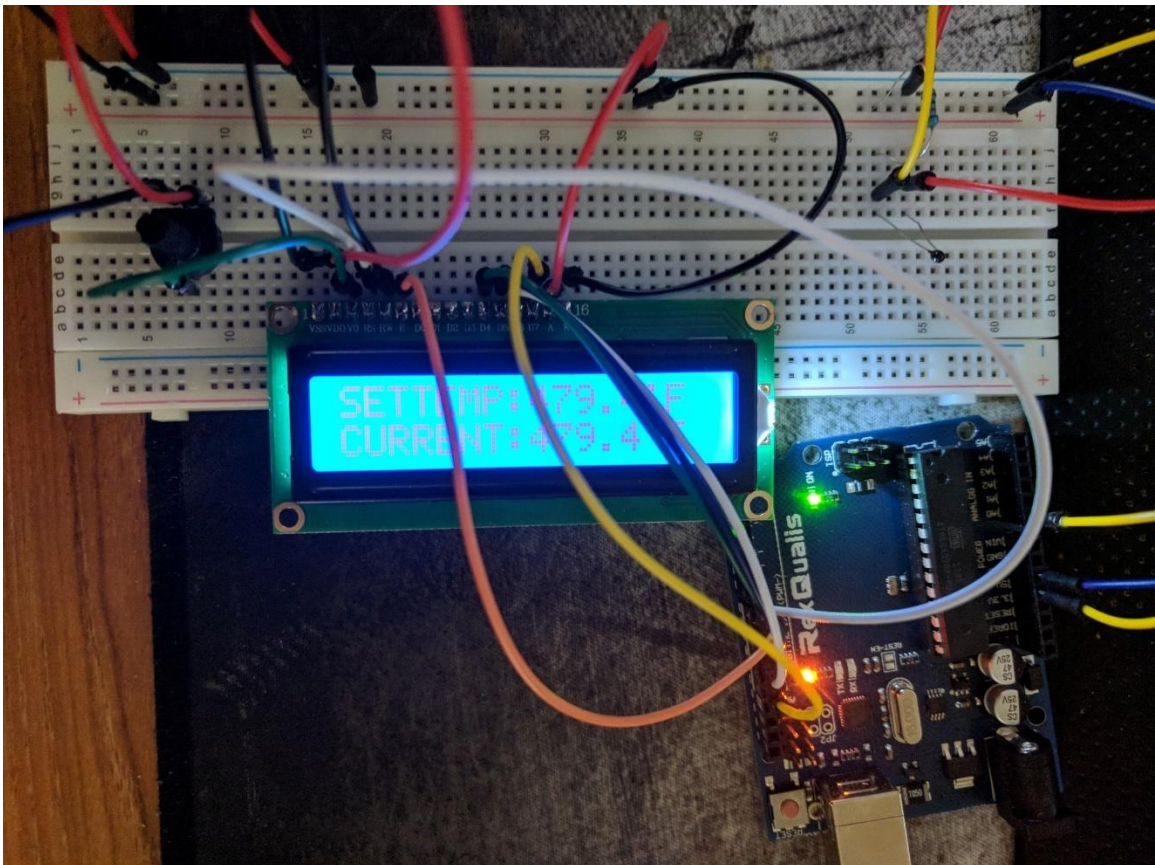
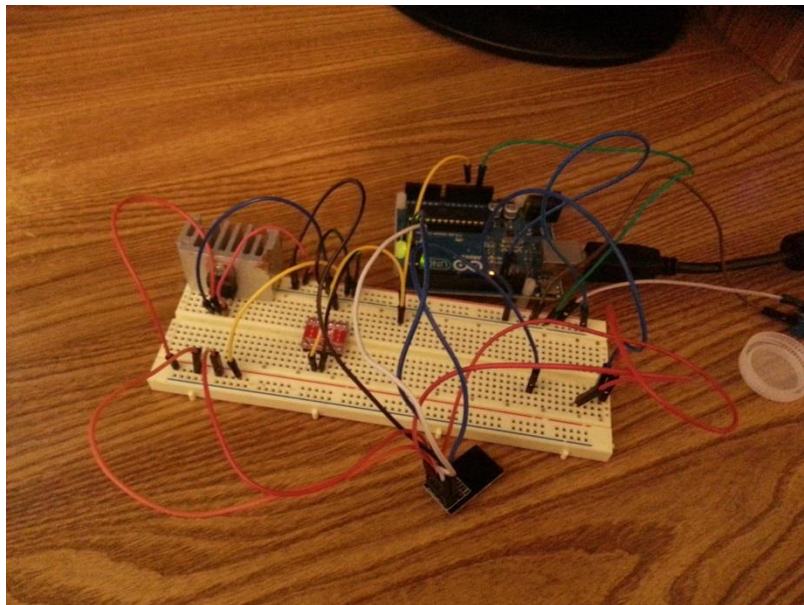

Figure 32: LCD with Temperature Prototype.

## 9.4 Setup Mode Prototype

The purpose of this prototype was to demonstrate the ESP 8266 Wi-Fi module's ability to act as an access point. The Arduino Uno was set up to act as a programmer for the Wi-Fi module by connecting their RX and TX pins via a bi-directional logic level converter. Logic signals coming from the Arduino and going to the Wi-Fi module are shifted from 5V to 3.3V. Logic signals coming from the Wi-Fi and going to the Arduino are shifted up from 3.3V to 5V. Figure X shows these connections on a bread board. The Arduino was powered by a computer via a USB cable. The Wi-Fi module was powered via a 3.3V voltage regulator supplied by a variable power supply unit set at 5V. A 5V and 3.3V signals was also applied to the logic level converter as reference voltages. The Wi-Fi module, Arduino, bi-directional logic level converter and the 3.3V regulator were all connected to the same ground rail. To program the Wi-Fi module it must be set into "programming mode." The Wi-Fi is set into programming mode by connecting its GPIO pin 0 and then briefly connecting the reset pin to ground. Connecting GPIO pin 2 to ground can sometimes prevent the Wi-Fi module from entering programming mode. Once connected and in programming mode, the Wi-Fi module can be programmed directly by the Arduino IDE (set in ESP 8266 compilation mode).



*Figure 33: Setup Mode Prototype*

A program was created and flashed to the Wi-Fi module which made it function as an access point "Control Unit AP ED32" and web server on that access point with the IP address "192.168.1.4". Figure X shows the control unit access point appearing in a list of nearby networks. With the password "testpassword" a Wi-Fi enabled device can connect to the access point.

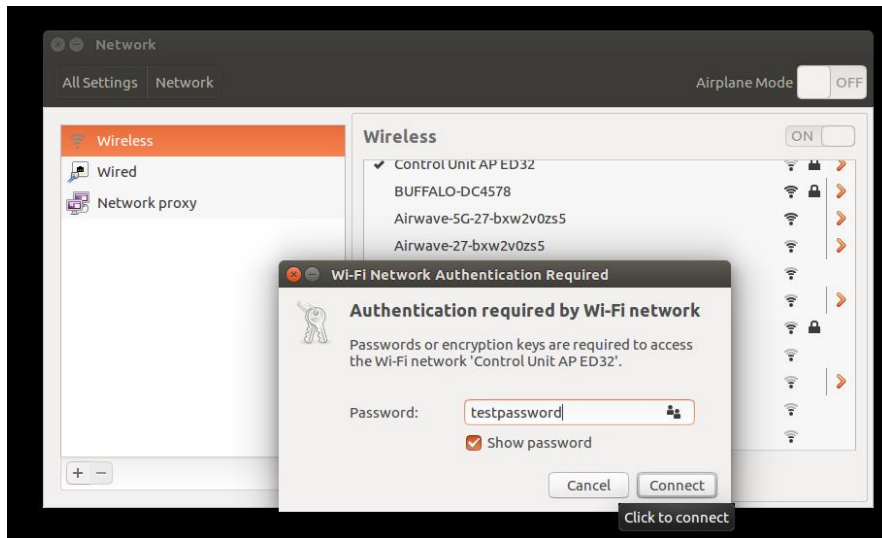

Figure 34: Control Unit Access Point

Once connected to the Wi-Fi module access point the user can access the Wi-Fi module's configuration web page in browser by entering its url "192.168.1.4". The user can modify the configuration settings of the control unit by entering values into the web page and hitting "Submit Query". Figure X shows the configuration web page sent by the control unit.

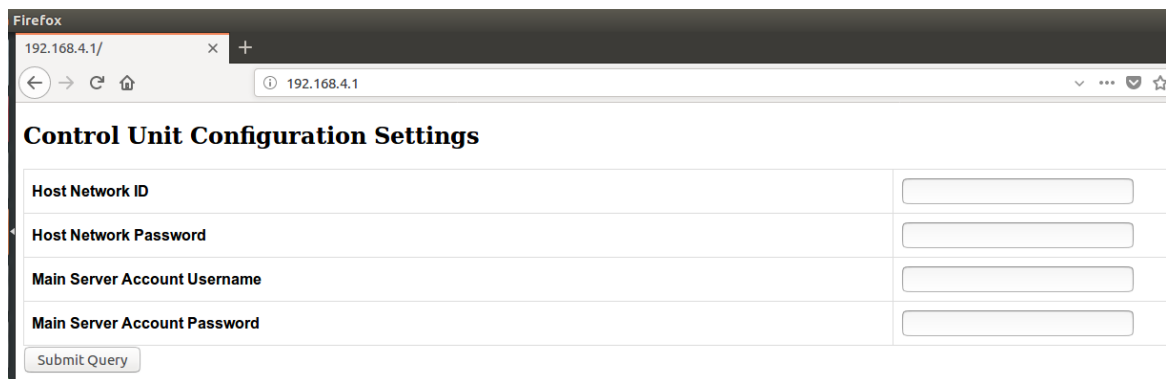

Figure 35: Wi-Fi Module Configuration Web Page

The Wi-Fi module then processes the values sent from the user's browser and adjusts its internal configuration settings accordingly. Figure X shows the serial feed from the Wi-Fi module after receiving configuration settings from the Wi-Fi enabled device.



```
~ld
GET / HTTP/1.1
Client disconnected
GET / HTTP/1.1
Client disconnected
GET /action_page.php?hostnetworkid=somenetworkssid&hostnetworkpass=someuserneworkpassword&hostnetworkid=someuserneworkssid&hostnetworkid=s
Client disconnected
```

Figure 36: Wi-Fi Module Serial Feed

## 9.5 Button Interaction Prototype

The temperature reading prototyped helped us demonstrate how we would handle analog readings and displaying them to the LCD. To get practice with digital readings, another thermostat component prototype was created. This time the prototype was for using buttons to change the “SETTEMP” value on the LCD screen. This can be seen in the figure below. An Arduino kit was used to for this prototype, with two buttons being connected to two of the digital I/O pins on the Arduino. The system was programmed such that pressing one button would increment the integer on the screen and the other would decrement the value. This prototype helped to teach a number of lessons. The first is the need to define the pins the buttons are connected to as INPUT\_PULLUP pins. The other end must be connected to ground. This way we can have the system respond to the pin going low, as pressing the button will close the switch inside pulling the pin from high to ground. The other important was the use of delay after button presses. If there is no delay programmed in, then the user giving a slight press to raise the temperature one degree could result in the value going up by many more degrees than intended. To fix this, after we adjust the value we want to have a slight delay programmed in to prevent this.

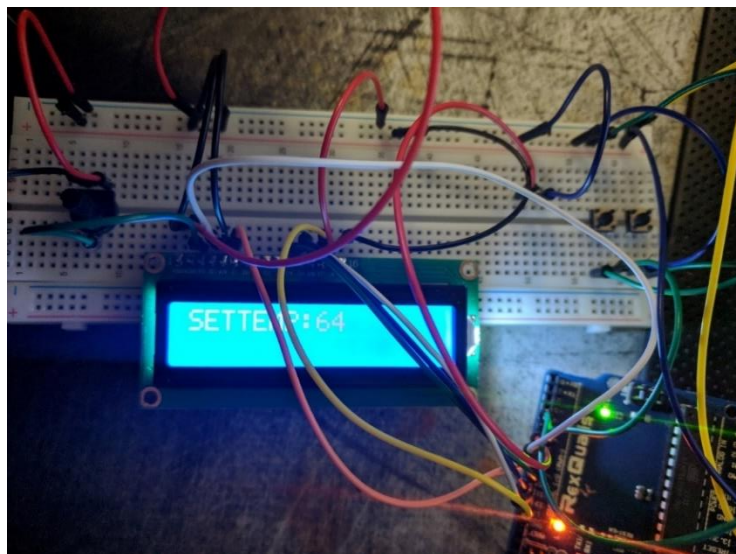

Figure 37: Button Input Prototype

## 9.6 Relay Prototype

Relays are the core of the remote functionality of the devices in our system, so it is very important that we prototype a relay to make sure we understand the process beforehand. The figure below shows a picture of this prototype. In the prototype we switch a relay to turn a small fan on and off. In the prototype a driver and breadboard power supply were used to supply power to the relay which is slightly different than what we ended up doing. We instead would end up using a solid-state relay since the MCU couldn't source enough, but the concept was the same, especially on the software front. The Arduino's digital output pins were configured to not only turn the fan on and off but also switch the direction of the fan. This was accomplished by switching which digital wires are high and which ones are low, on the fly. This is an interesting tactic to keep in mind for the final build of our project.

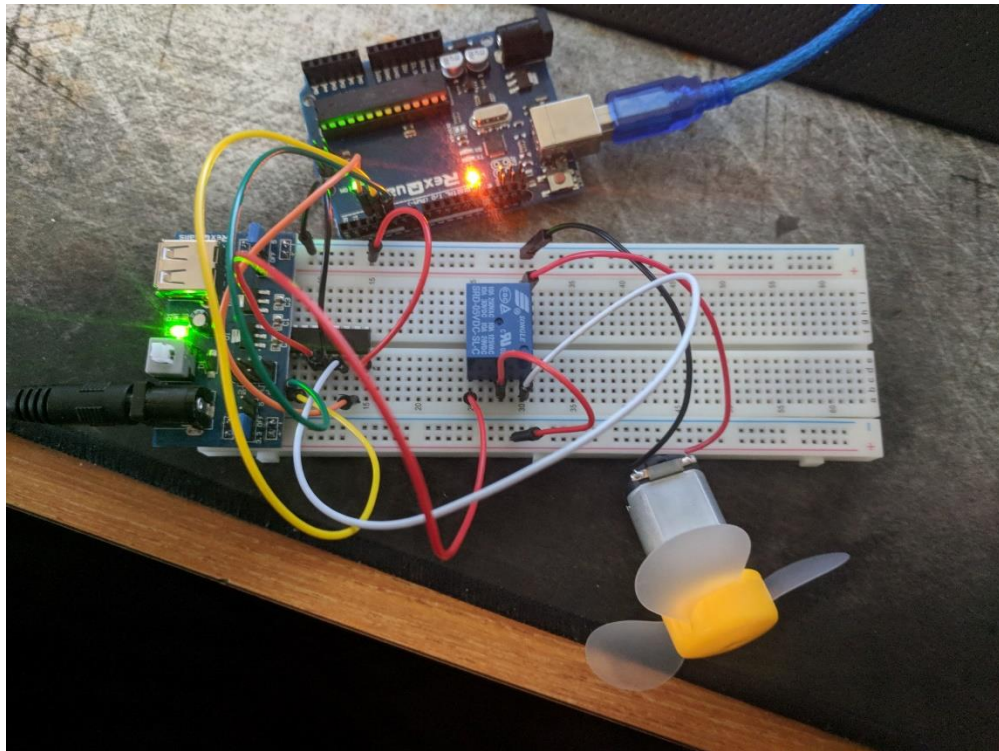
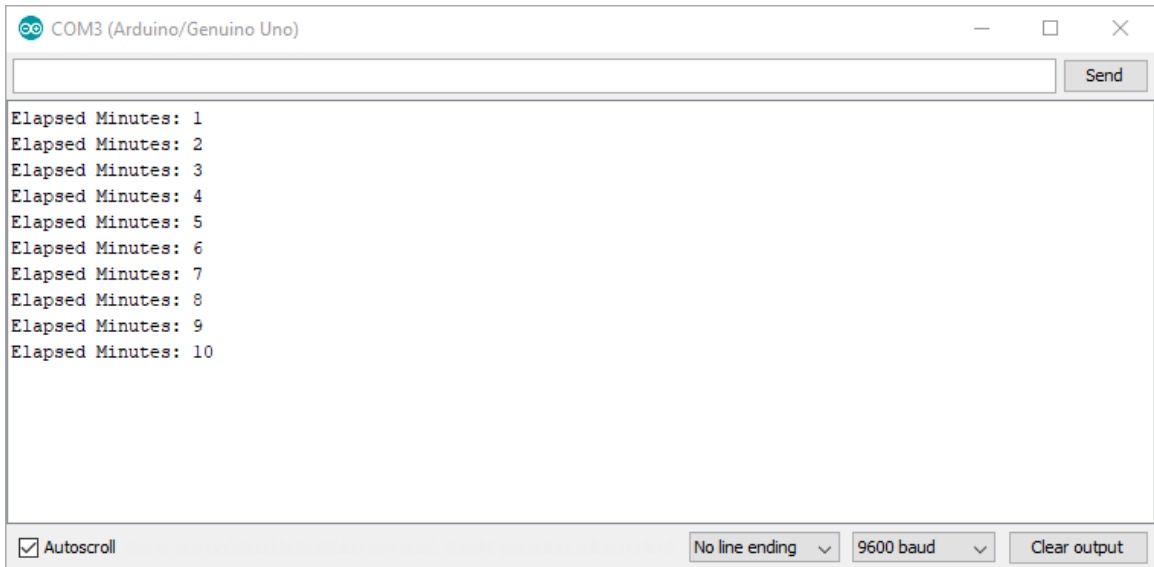

Figure 38: Driver Prototype

## 9.7 Minute counter Prototype

Time accuracy was crucial to properly informing the users of our system of their power usage. If we did not properly track the time at which a user is consuming

power, we would have been misleading them in how their device usage habits effect their power consumption. To minimize this risk, we prototyped how the minute value would be tracked on the Arduino. To do this we programmed the Arduino to compare the millis() value, or time in milliseconds since the Arduino has started, with a variable that updates whenever the millis() value is over 60,000 higher than this variable. This variable then gets updated with the current millis() value. The end result was the ability to perform certain actions every minute. For prototyping purposes all we did was print a message to the serial terminal once a minute for 10 minutes while monitoring a digital timer to make sure the value was updating as accurately as possible. While we were doing more than just printing to a terminal in the final build, this prototype acted as a good proof of concept for the way in which we intend to track time.



*Figure 39: Minute counter prototype output*

## 9.8 PCB Vendor and Assembly

A custom PCB is an integral component of our project. The custom PCB will allow for all of our modules to seamlessly be connected together in one clean board. This custom PCB however must be designed and manufactured. To manufacture this PCB the design files must be submitted to a PCB manufacturer for them to create the board. Once the board is created, the final product is mailed back and final components can be added. There are many different PCB manufactures that have their own unique creation time, size, layer and shipping delays. These different manufactures were examined in more detail below to determine which the best for our needs are.

### **9.8.1 PCB CART**

PCB Cart is a PCB manufacturer that does a variety of PCB from prototype to Advanced PCB. To save time and development costs only the prototype PCBs will be considered. PCB Cart's prototype PCB designs are quite flexible. The PCB manufacturer allows from 1 to 8 layers on their prototype board. This gives a large amount of flexibility in routing. Additionally they allow for a large and small amount of boards to be ordered. Their prototyping PCBs can be ordered in quantities ranging from 5 to 100 pieces. Their board size is also quite flexible. They allow a maximum size of 500mm by 500mm and a minimum PCB board size of 6mm by 6mm. The development time is also quite fast with board creation taking as little as 4 days. The cost of a 2 layer board is quite reasonable as well with it costing roughly 50 dollars for 5 prototype boards.

### **9.8.2 Custom Circuit Boards™**

Custom Circuit Boards is another PCB vender that specializes in both production and prototype PCBs. They can have from 1 to 40 layers. This gives a huge amount of flexibility in routing. In addition, Custom Circuit Boards has the ability to make two layer boards a maximum size of 20 inches by 28 inches. The largest advantage that Custom Circuit Boards has is that it can produce circuit boards as fast as 24 hours. This can help greatly when extremely fast prototypes are needed. They also support a variety of solder masks such as green, white, black, blue or red. Unfortunately, they do not have quotes on their site without submitting a PCB design file. Because of this, it is unclear how they fair in price. It was a considered vender however if extremely rapid service is needed to create a prototype.

### **9.8.3 Gold Phoenix Printed Circuit Board Co.**

Gold Phoenix is another PCB vender that specializes in many unique PCB designs. One very unique service that Gold Phoenix offers is specialized board materials. Along with the standard rigid PCB materials, this manufacturer offer flexible PCB boards. While this is not is most likely not a useful in our project the ability to use it is a nice potential to have. There more traditional PCB board manufacturing capabilities have many options as well. They allow for up to 20 layers which was many more than was needed. They also allow for quite small holes in their PCB designs. Gold Phoenix can have finish holes that are as small as 6 mm with a tolerance of 3 mm. Like many vendors, Gold Phoenix allows for many solder mask colors. They allow for green, black, red, yellow, white, purple, and blue. This gives our board many cosmetic choices to choose from. They also

have a potential for silk screens on the board. This gives the option to label key components and pins which can make soldering much easier because a schematic does not have to be constantly referenced to see which part goes where. Lastly Gold Phoenix allows for very large PCB boards. For single or double layer boards the maximum board can be as large as 59 inches by 50 inches which is insanely large. The minimum board size that they offer is 0.2 inches by 0.2 inches which is extremely small. The huge variety of board sizes gives our designing a very large flexible capability. Gold Phoenix Printed Circuit Board Co. does not provide live price estimates by PCB dimensions. This makes comparing the prices they offer difficult because of the time they need to evaluate the board design file submitted.

Every PCB manufacturer has its benefits and drawbacks. Because they all have good and bad attributes, no single PCB vendor was considered when ordering our custom boards. Instead the manufacturer that is picked for making our prototype was selected based on our current needs. If time was not a current constraint we will go with a PCB manufacturer that provides lowest cost for our design. Conversely if time is the biggest constraint we will go with a manufacturer such as Custom Circuit Boards which can design our prototype board within one day for fast delivery.

#### **9.8.4 Final PCB Vendor**

For this project only one PCB vendor was used to produce the boards. This PCB vendor was JLCPCB. They were chosen for multiple reasons. The first reason was that they were one of the cheapest producers of prototype boards available. For our board size, manufacturing and shipping only cost 20 dollars. This price was significantly lower than any PCB vendors located in America. The other reason they were used was because they provided very fast turnaround times. JLC PCB manufactured boards within 2 days. On top of this, their shipping usually only took roughly 2-4 days. This meant the boards could be produced and shipped in less than one week. Because of the low cost and fast production they were the only PCB vendor used for our project.

### **9.9 Part Acquisition**

Parts were acquired from multiple vendors based on current market prices and discounts offered. Primary vendors and the products they specialize in are shown in the table below. A large selection of vendors were used to maximize the efficiency of the budget, minimize time waiting for products to ship/arrive and maximize the overall quality of the system. The table below shows the different vendors.

Table 27: Vendors

<b>Vendor</b>	<b>Relevant Products</b>
<b>Digi-key</b>	ICs, Resistors, PCBs
<b>Mouser</b>	ICs, Resistors,
<b>Ebay</b>	Electronic Components
<b>Sparkfun</b>	Jumper wires, logic level shifters
<b>Adafruit</b>	ATMega chips
<b>Amazon</b>	Capacitors, Vuvuzela, Soldering Paste
<b>Walmart</b>	Flux pens, desoldering braids
<b>Pololu</b>	PCBs, ICs, ATMega chips
<b>DFrobot</b>	Wiring, Solder, Relays
<b>All Electronics</b>	Arduino Uno Boards, Bread Boards
<b>Waveshare</b>	TQFP Adapters
<b>BGMicro</b>	Switches, Solder Tip Cleaners, Flux Paste

## 10.0 Administrative Content

The following section details various non-technical aspects of our project. These include our budget, which approximates the total cost required to acquire the necessary components to build our system, and a milestones section which details some important milestones we hope to accomplish.

### 10.1 Budget

As the goals of this project included helping users to reduce power consumption and informing users about their power habits and the cost of these habits, Group 10 planned to seek sponsorship from Duke Energy. Consumers saving electricity also results in savings for energy companies, therefore we believed that Duke Energy's interest to finance a project such as ours. When Duke Energy did not approve our energy request, our senior design project became self-funded.

Table 28: Expense Breakdown

Component	Quantity	Cost Per Component	Total Cost
Arduino Starter Kit	4	\$30	\$120
Microcontroller	3	\$10	\$30
ESP 8266 Wi-Fi Module	3	\$10	\$30
CT sensor SCT-013-000	3	\$12	\$36
Prototype Materials	Varied	Varied	\$150
Presentation materials	Varied	Varied	\$50
PCB Manufacturing	3	\$15	\$45
SMAKN Voltage Transformer	3	\$12	\$36
Digital Ocean Droplet Server Subscription	7	\$5	\$35
5V USB PSU	3	\$5	\$15
<b>Total</b>			<b>\$547</b>

Our project was developed on the Arduino platform, using Arduino based MCUs in each component in our system. Therefore it was important for each of our team members to buy Arduino starter kits to help familiarize ourselves with the technology we will be working with. A starter kit with the essentials costs roughly \$30 on Amazon. Our actual project required MCUs at each device which cost approximately \$10. Each device also required a module to allow them to interface with the Wi-Fi. The Wi-Fi module will cost from \$5-\$10. The system required assorted analog components to perform the power monitoring functions.

This cost around \$120 in total, including backups. The cost of a printing our own PCBs was also approximately \$45. We also planned on doing a few prototypes in order to learn how to perform some of the desired functions of our final system. We spent approximately \$150 on materials for prototyping. The final expense was materials required for presenting our project in a reasonable manner. Based on similar projects this involved creating a display board on a piece of plywood and using things such as light bulbs and other electronic devices to serve as sample loads. These materials cost no more than \$50. This puts the total maximum cost at approximately \$547.

## 10.2 Milestones

There were several critical milestones throughout the course of the project. A table was created to track these milestones and overall project progress. Group members agreed on the milestones and have taken responsibility for their completion. These milestones are by no means final and changed due to unforeseen circumstances. The table below shows the list of completed project milestones.

*Table 29: Completed Milestones*

<b>Milestone</b>	<b>Completion Status</b>	<b>Description</b>
Senior Design 1 Boot Camp	Complete	Ran several team building exercises and organized our ideas.
Final Project Decision	Complete	Came to a unanimous agreement to pursue this project.
Divide and Conquer Draft	Complete	Initial project outline and description.
60 Page SD1 Draft	Complete	First half the senior design 1 paper.
120 Page SD1 Draft	Complete	Complete and bounded senior design 1 paper.

The table below goes over our in progress milestones. All in progress milestones were completed by the end of senior design 2. These goals vary from very short milestones that will be quick to complete to long milestones that were only finished by the end of the semester. These milestones were by no means final and changed due to unforeseen circumstances.



Table 30: In-Progress Milestones

<b>Milestone</b>	<b>Completion Status</b>	<b>Description</b>
1 minute Power Usage Measurement System	In-Progress	A system which can measure the power usage of an attached load over a period of a period of 1 minute.
Setup Mode Prototype	In-Progress	Implement the setup mode functionality of a control unit.
Connect Mode Prototype	In-Progress	Implement the connect mode functionality of a control unit.
AC Control Unit Prototype	In-Progress	Implement an AC control unit with full functionality
Outlet Control Unit Prototype	In-Progress	Implement an Outlet control unit with full functionality
Switch Control Unit Prototype	In-Progress	Implement a Switch control unit with full functionality
AC Control Unit PCB	In-Progress	Full implementation of AC control unit printed circuit board
Outlet Control Unit PCB	In-Progress	Full implementation of outlet control unit printed circuit board
Switch Control Unit PCB	In-Progress	Full implementation of switch control unit printed circuit board
Main Server Prototype	In-Progress	Implementation of main server prototype
Control Unit Integration	In-Progress	Integration of control unit modules into single cohesive unit.
Control Unit – Main Server Link	In-Progress	Full implementation of link between control unit and main server

# 11.0 Testing

Testing was a critical part of project. Not only did it need to be confirmed that all individual components work correctly, but it also needed to be confirmed that they also needed to work correctly when connected together. To ensure this, circuit designs were simulated and experimentally tested for each module. When each circuit had been thoroughly tested and confidence that the design functions as expected, these individual modules were combined. Once again, these combined modules were tested to ensure that they communicated and functioned together flawlessly. When these tests had been done they were finally tested on the printed circuit board. The preliminary testing was done to reduce troubleshooting issues and the number of prototype circuit board that needed to be designed. The testing of these modules and the methods used to do this testing is explored in more detail below.

## 11.1 Voltage Measurement Testing

The testing of the voltage divider for voltage sensing was first done by simulating in LTspice. The circuit for the voltage divider, shown in section 7.11, was built in LTspice and then simulated. The figure below shows the output waveform of the voltage divider, level shifter, and operational amplifier when the source voltage is set as a 170 volt peak, 60 Hz sine wave.

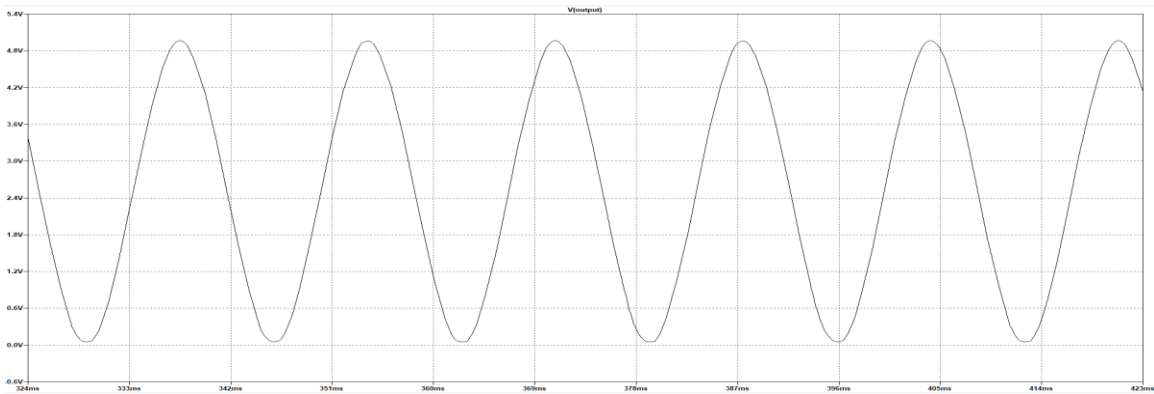

Figure 40: Output Waveform of Voltage Sensor

As expected the output waveform was a sine wave centered at 2.5 volts, with peaks at 0 and 5 volts. When the source voltage was increased the output of the operational amplifier went to the power rails, which protects the analog to digital converter.

## 11.2 Current Measurement Testing

Testing the current sensor was done in two different ways. First the shunt with the two stage amplifier was simulated using LTspice. After the circuit was simulated and the expected results were seen, the circuit design was hardware tested using a breadboard. The circuit design shown in section 7.10.1 was built in LTspice and then simulated. The voltage across the shunt and the two output waveforms when 15 amps is flowing through the shunt are shown in the figure below.

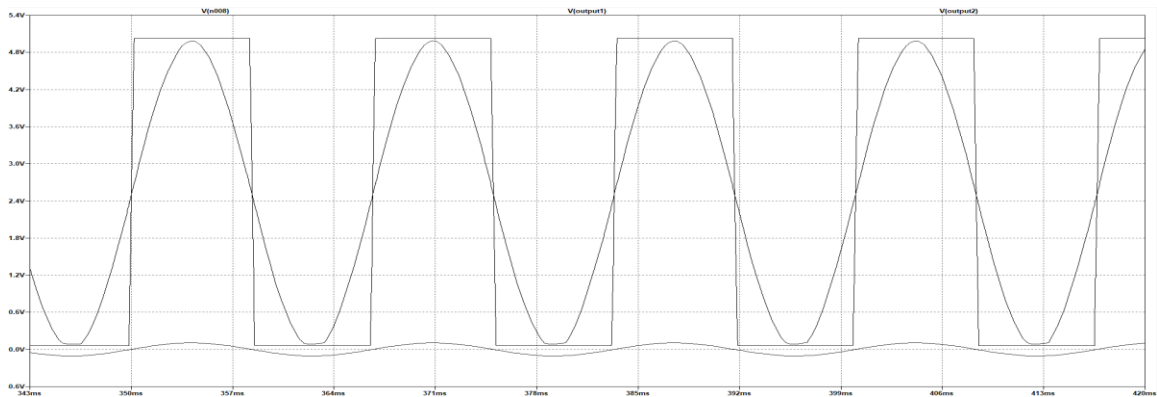

Figure 41: Output Waveform at 15 amps through the Shunt

The figure above shows the output of the second stage amplifier as the square wave. The output of the first stage amplifier is shown as the smooth sine wave. The voltage across the shunt is shown as the small oscillating sine wave centered at 0 volts. As expected the output of the first stage is centered at 0 volts with peaks at zero volts and 5 volts. This is the largest waveform that the MCU sees. The output of the second stage of the amplifier is seen to be a square wave with peaks at 0 volts and 5 volts. The reason that this waveform is from 0 to 5 volts is because the maximum peaks that the operational amplifier can output is the power rail voltage, which is  $\pm 6$  volts. Since the second stage amplifier is amplifying the already large output from the first stage amplifier the waveform goes directly to the power rails. This will help distinguish which waveform to read and also protects the MCU from any voltages that it cannot handle. Now as the current through the shunt decreases the square wave output from the second stage amplifier turns into a sine wave ranging from 0 to 5 volts. As this happens the output waveform from the first stage amplifier decreases into an almost unreadable waveform. The figure below shows the output waveform of each stage of the amplifiers as well as the voltage across the shunt.

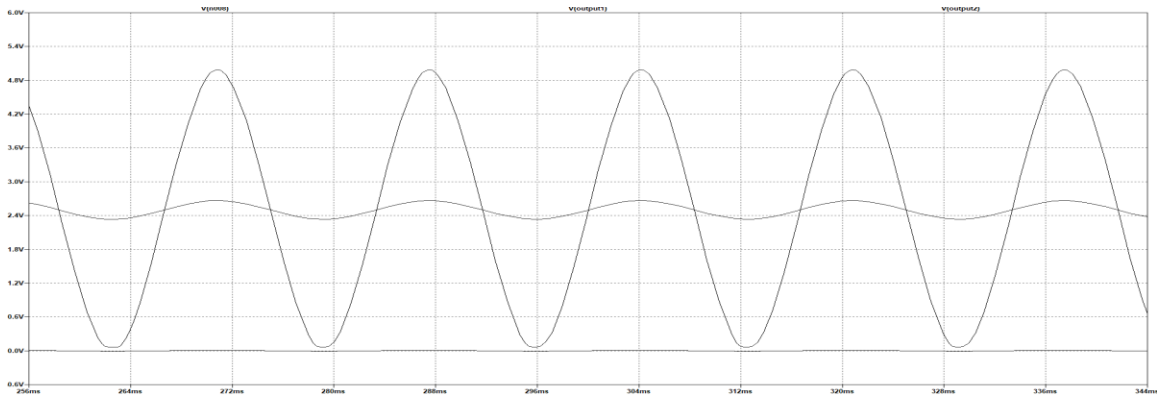

Figure 42: Output Waveform at 1 amp through the Shunt

The figure above shows the output of the second stage amplifier as the smooth sine wave ranging from 0 to 5 volts. The output of the first stage amplifier is seen to be the small sine wave centered at 2.5 volts. Finally the voltage across the shunt is seen as the small sine wave centered at 0 volts. As expected it is seen that for 1 amp of load current the output waveform ranges from 0 to 5 volts and any higher load current would result in this waveform beginning to clip. This is when the output waveform from the first stage amplifier will be read instead of the output from the second stage amplifier.

## 11.3 Input Voltage ADC Testing

The analog to digital conversion is one of the most important components in the project to confirm output is correct. Because the internal analog to digital converter of the ATmega2560 is being used to complete this task, various analog signals will be sent to this device. To ensure the full range of voltages is realizable, an analog read of zero and 5 volts was read. Because the conversion is 10 bits, the minimum and maximum integers that should be read was zero and 1023. These values confirmed as output when zero and 5 volts are inputted. Once the basic operation of the ADC was confirmed to work, the next step in testing was to attach the voltage and current analog signals to the microcontroller. These signals were both sinusoidal signals that will range from zero to 5 volts to get the most resolution from the analog to digital converter. These signals were converted and their output was confirmed to move in a sinusoidal pattern. These sinusoidal values were then rescaled to their proper value. Because the voltage scaling factor will be constant, the integer value was first be multiplied by 4.88mV which is voltage the integer represents. This will convert the integer value into a voltage value. This voltage was then be scaled up to take into account of the scaling down of the input voltage through the voltage divider. Because the voltage divider reduces the voltage by a factor of roughly 34, in software this input voltage was multiplied by 34 to retain the full 170 volts amplitude.

## 11.4 Input Current ADC Testing

A very similar conversion that was used for the voltage testing was used to test the analog to digital conversion for the current sensing. To confirm the pin that is connected to the current ADC, two test voltages of zero and 5 volts was inputted on the pin. If the converter is working correctly, an input of 5 volts will result in an integer number of 1023 and an input voltage of zero will give an integer value of zero. When the basic functionality of the analog to digital converter pin was confirmed to work properly, a more complex signal will be applied to the pin. Because the device has two amplification ranges, the current sensing will also require two analog to digital conversion pins. Each pin needed to be tested to confirm that scaled result is being correctly converted into the expected integer. When the low amplification current sensor is tested, the digital output was first observed to oscillate in a sinusoidal manner. When this result is seen, it was then tested to see that the expected current draw matched scaled digital result. This was tested first applying a known constant load. This load was then compared with the properly scaled readings from the analog to digital converter to confirm that the values closely match. Once this was tested the high-resolution ADC will be tested. This was tested by applying a small but known load to the shunt. This load was then compared to the scaled current measurements that come from the analog to digital converter. These measured values was compared closely to the known values and made sure to match before the analog to digital converter is confirmed to truly work properly.

## 11.5 Temperature Testing

The temperature testing was vital to ensure that the thermostat module will work correctly. A malfunctioning thermostat had the potential to set the users temperature higher or lower than the user expects which not only makes the user hotter or cooler than expected but also had major power ramifications. A thermostat that turns on when it should not can greatly increase a consumer's energy usage which is exactly what this project was attempting to reduce. To test the one wire thermometer selected the module was first powered and connected to the microcontroller. Once this was accomplished, any output will be attempted to be read out to confirm the unit was turned on and powered properly. When the unit was confirmed to power on, the actual measuring of the device was scrutinized. The thermostat's output was compared with an external self-contained thermometer and the temperatures were compared. If these temperatures were measured to be close to each other over a wide range of temperatures the module was confirmed to be operating as expected and were attached to the PCB.

## 11.6 Power Transformation Testing

Thoroughly testing the power transformer was essential for ensuring that our low voltage devices work properly. To test the transformer the first thing that was tested is the input voltage. The device was tested to ensure that there is not a bad connection and that it is receiving the full 120 volts RMS for the input. This was tested by the use of a simple digital multi-meter. After that was confirmed, the output voltage was tested. The output was checked to see if the waveform was much lower voltage than the input. After the voltage was confirmed to be much lower, rectification and ripple reduction was tested. This was tested through the use of an oscilloscope. The oscilloscope showed if there is an unacceptable amount of ripple and if the voltage is the right voltage. Once the output is confirmed to be a clean low voltage DC waveform, the testing of the power transformation was completed.

## 11.7 LCD Testing

Properly testing the LCD was important to make the user is properly being told what they have their temperature set to and what the temperature of the house is. If they think their A/C unit is set at a higher temperature than it actually is they make turn it down further, wasting power. To verify proper operation, we will conduct testing in three phases. The first will be pushing information to the LCD that is hard coded into the LCD. This consists of writing the information we want to write to the display, including the "SET TEMP" and "CURRENT TEMP". After we confirm we can write to the display and thermometer testing has concluded we will test that the LCD will accurately display changes in temperature. We can do this by putting the thermometer under different temperature conditions and monitoring the LCD to make sure it is updating accurately. The final stage will consist of testing the buttons and response of the system. To do this we will adjust that when the 'UP' button is pressed, the "SET TEMP" value increases by one, until our cap of 85 degrees after which it should display the "AT MAX TEMP" warning. Likewise, we will test the LCD properly displays the decremented "SET TEMP" value when the 'DOWN' button is pressed until the floor of 65 degrees at which point the LCD should display the "AT MIN TEMP" message.

## 11.8 Module Stubs

Stubs were created for interacting software components of the project. The purpose of these stubs was to reduce integration issues. Stubs of components which were worked on by two different team members were verified by both team members to avoid confusion. For example, team members Jonathan Killeen and

Adam Althar were both working on two interacting components: Wi-Fi communication module and power usage measurement module. Each member created a stub program which can simulate the functionality of their modules.

## 11.9 Wi-Fi Communication Testing

To ensure our power data is properly being transmitted to the database we needed to conduct testing of this data transmission. To do this we configured the database to echo back whatever data it receives from the Wi-Fi module. This consists of manually coded data be sent from the MCU over the Wi-Fi module, then reading the data that is sent back. If we received the exact same information back from the database that we transmitted to it, we knew that our communication was operating successfully.

The ESP 8266 Wi-Fi module can be tested directly using AT commands sent from a computer via an Arduino Uno board. The "AT" command I used to test if the ESP 8266 Wi-Fi module has successfully initialized. If the ESP 8266 Wi-Fi module was successfully initialized it will return "OK" whenever it receives the "AT" command. The "AT+RST" command restarts the ESP 8266 module. When the ESP 8266 Wi-Fi module receives the "AT+GMR" command it sends back the AT version info, SDK version info, and last compile time. When the ESP 8266 Wi-Fi module receives the "AT+GSLP=<time>" command it will enter deep sleep mode for the time value received. "AT+RESTORE" restores the ESP 8266 Wi-Fi module to default factory settings. There are some AT commands that double as both get and set commands. One such QS command is "AT+UART". When used by itself "AT+UART" is used to query the ESP 8266 Wi-Fi module for the current UART configuration. When used as a set command ("AT+UART=<baudrate>,<databits>,<stopbits >,<parity>,<flow control>") it will modify the ESP 8266 Wi-Fi module UART configuration settings. It should be noted that these are the UART configuration settings which are saved in flash. To get/set current UART configuration settings in use you would send the "AT+UART\_CUR?" Command. The default factory UART configuration settings of the ESP 8266 Wi-Fi module can be set/retrieved using the "AT+UART\_DEF" command. AT sleep commands may not be used in this project. The "AT+RFPOWER" set only command is used to current radio frequency transmission power value for the ESP 8266 Wi-Fi module. The "AT+SYSRAM" command will be used to get the current remaining RAM space on the ESP 8266 Wi-Fi module. The "AT+SYSIOSETCFG" command can be used to set the current configuration for each of the two digital I/O pins on the ESP 8266 Wi-Fi module. The "AT+SYSGPIODIR" command will be used to set the direction of the ESP 8266 Wi-Fi module I/O pins. The "AT+CWHOSTNAME" set commands the host name of the ESP 8266 Wi-Fi module. We will use the "ATE" command to turn AT command echoing on (ATE1) and off (ATE0). The "AT+CWQAP" command will be used to disconnect from the current connected AP. The "AT+CWAUTOCONN" command will be used to configure the ESP 8266 Wi-Fi

module to connect automatically to the AP specified in its flash memory on boot. We can use the "AT+CIPSTATUS" command can be used to get the current connection status. We will use the "AT+CIPSSLSIZE" to set the SSL buffer size on the ESP 8266 Wi-Fi module. Using the "AT+CIPSEND" command we can send data across the network to the currently registered destination address. "AT+CIPSTART" is used to establish a TCP, UDP or SSL connection with another device. With "AT+PING" we can test the ESP 8266 Wi-Fi module's ability to send ping packets across the network. The current SNTP time can be queried using the "AT+CIPSNTPTIME" command.

## **11.10 MCU Timekeeping Testing**

We needed to perform adequate testing of the ability of the microcontroller to keep an accurate count of the real-world time in minutes. To test the accuracy of the code designed to track time we started each of the three devices in our system at a different time, making note of the real-world time when the process is started. We then had them retrieve the current real-world time in UNIX time at various times. We then had the microcontroller print the current value stored of the minute tracker variable to the serial. After that, we compared the value that is output against the real-world world time to check the accuracy. Testing at various points in time had a couple of benefits for testing. First, the longer the system ran the more noticeable the inaccuracies of the clock could have become. Testing over a long period of time helped to tell us if we are accurately tracking time or if we need to reevaluate our methods. Additionally, for our original plan, going for a long period of time allowed us to test that our minute variable is rolling over properly. Since we should only receive values from 0 to 1440, if we see something outside of that range we know we are not properly rolling our time over. However since our final build used UNIX time this original concern was no longer present.

## **11.11 Facilities and Equipment**

It was important to have a location that was able to facilitate designing, testing, troubleshooting of a project. There were two locations that we used as our facilities to work on the smart energy monitoring project. The first and most frequently used facility was the Texas Instruments Innovation Lab. This lab was ideal for many reasons. This facility had many tables to build and debug any part of the project. In addition, the Texas Instruments Innovation Lab had many components on hand. These parts were able to be a huge asset when a quick prototype was desired to be built or when a common component was forgotten. Almost all parts within the lab were given away freely as long as permission to take the component was asked for first. This greatly helped in reducing the



budget by recycling parts or using parts already purchased by others. The facility also had a great deal of prototyping and testing equipment. The Texas Instruments Innovation Lab has soldering stations, 3D printers, oscilloscopes, digital multi-meters, and signal generators. This equipment was almost all equipment needed to test our project's modules and solder components on a PCB. The figure below shows the facility and its large open tables the lab had to offer and some of the various equipment on the premise.



*Figure 43 Texas Instruments Innovation Lab Equipment*

The other testing facility that was utilized when designing and testing our project was the Senior Design Lab. When the Texas Instruments Innovation Lab was too full the Senior Design Lab was used instead. The Senior Design Lab is a large facility that had many tables for working. They also had some extremely basic components there such as resistors and capacitors as well. The components they did have was free as well which made it a convenient place to get common components for our project. They had some testing equipment as well such as oscilloscopes and function generators. While the Senior Design Lab did not have as much equipment or parts as the Texas Instruments Innovation Lab, it made up for its deficiencies by being typically quieter and having less people in its facilities. The Senior Design Lab was also available 24-hours a day, which was incredibly useful as we approached the end of our project and needed to spend as much time as possible working on our project.

## 12.0 System Setup and Operation

This section covers the basic setup and registration of a control unit. As all control units possess setup/connect mode functionality this section can be applied to all unit types. Failure to adhere to the instructions in this section can result in a control unit being unable to connect to the main server.

Step 1: Set the unit into setup mode by pressing the connect/setup mode button.

Step 2: Connect to the “ESP8266 Setup” Wi-Fi network using a tablet, smart phone or personal computer.

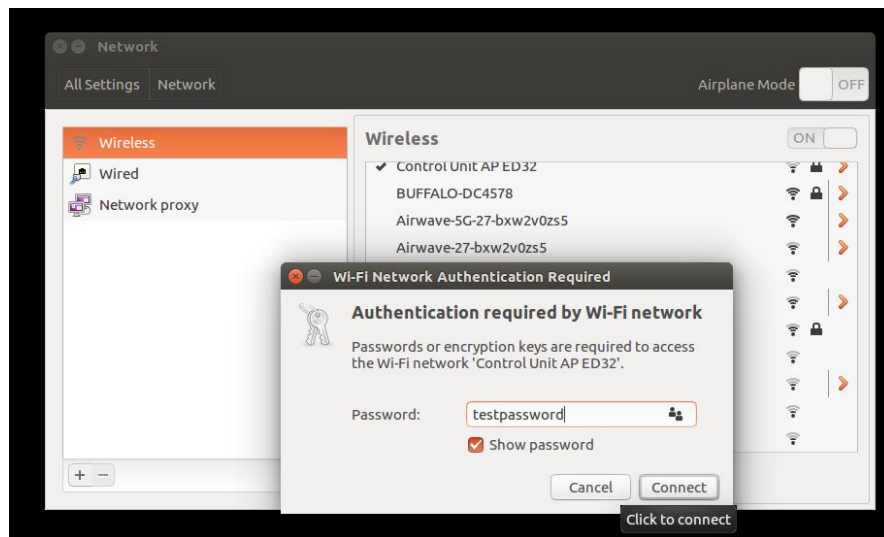

Figure 44: Control Unit Access Point

Step 3: Navigate to 192.168.1.1 in the smart phone, tablet or personal computer internet browser to access the control unit configuration page.

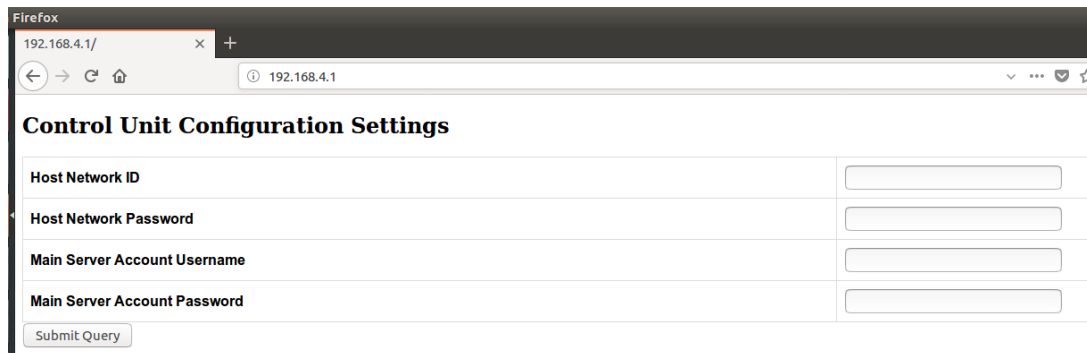



Figure 45: Control Unit Configuration Page

Step 4: Enter in Wi-Fi credentials for the user network, the user account credentials and a device name and click submit. If the configuration settings were changed successfully the browser should redirect to a confirmation page and the control unit will reboot in connect mode.

Step 5: Wait 3 minutes for the control unit to register itself with the server.

Step 6: Connect your tablet, smart phone or personal computer to the internet and navigate to the main server website (on VM version ip address 192.168.11.120).

Watt You Pay For



**Username**  
testaccount

**Password**  
\*\*\*\*\*

[Login](#)

[Sign Up](#)

Figure 46: Main Server Login Page

Step 7: Enter your account credentials and log in. If the control unit has successfully connected and registered with your account, it should appear in the control area at the bottom of the page.

Device	Relay Status	Temperature	Controls	
Night	ON	76	<input type="button" value="ON"/>	<input type="button" value="OFF"/>
Light	OFF	N/A	<input type="button" value="ON"/>	<input type="button" value="OFF"/>
Outlet	OFF	N/A	<input type="button" value="ON"/>	<input type="button" value="OFF"/>

Figure 47: Server Control Panel

## 13.0 Project Summary and Conclusion

Energy conservation and 'Smart' internet-of-things devices are two topics that will have an impact well into the coming years. Our project was chosen due to the increasing relevance of these topics along with our team member's interest in the topic. Based on the energy usage statistics we researched, we believe that addressing a light switch, thermostat and outlet helped us to address the most important consumers of energy in the home. Our thermostat did not display much information besides the current ambient temperature and the set temperature. Additionally, the light switch and the outlet were simple yet functional, which is what most users would want out of a smart device. Based on our research showed that what differentiates these products is how they handle their interface and controls. This meant what was most important was our web interface. Presenting our users with clean, understandable data is what will truly educate our users to better understand how their energy consumption habits manifest. For example, when a user sees just how much more energy the air conditioning and heating unit requires compared with the lights or the outlet, the user can better understand that they need to reduce their cooling and heating usage if they want to have any sort of noticeable impact on their energy consumption. Additionally, features such as the day by day and month by month views help the user to see if they are actively improving their energy consumption habits over time. The user being able to see the total consumption going down month over month will help to tell them that they are tangibly improving their consumption habits. We think that educating users is one of the most important steps in reducing their energy consumption and our web-based interface helps to do this very well. Likewise, the ability to remotely turn on and off the light switch and outlet gives the user even more control over the system, which allows them to reduce their power consumption even further. For example, if the user left a device plugged in to the outlet or left their lights on when they left their house, our system allows the user to remotely turn off the device, further saving energy. This capability is the biggest upside to us choosing to use Wi-Fi over other communication methodologies such as Bluetooth.

In conclusion, we believe that our project effectively satisfies our goals and motivations that we had laid out prior to beginning work on our project. Our group learned a lot during the entire processes. For example, one of the areas that gave us the most trouble was also one area that we learned the most, which was attempting to use a mechanical relay. Since this relay had an inductor in it, this component introduced many complications as a result of discharge and EMF from the inductor. Now that we understand the benefit of a solid-state relay we feel much more comfortable about working with similar components in the future. The various lessons like this one made us all understand the importance of doing a project such as this and how they will benefit us in the real engineering world. Going forward, if we were to continue to refine our system there is a number of improvements we could make to our system if we chose to. For example, our system's infrastructure allows for us to add devices very easily, so if we wanted

to add something like additional light switches or discreet appliances we could easily do this. Additionally, we could attempt to add more ways for the user to manage their system, such as allowing the user to schedule when they want their devices on or off or integrate GPS functionality so that these devices would only work when the user's cellphone is within a certain range of their house. Overall, our team is very satisfied with the quality of our project and very happy with what we learned from this experience.

# 14.0 Appendix

The final section of this report contains miscellaneous resources that were used for the creation of the paper not explicitly mentioned in the report. This includes sites that helped use better understand how to create a report of a high quality along with all permissions from various companies to use either their intellectual property or images in the image.

## 14.1 Resources

[https://en.wikipedia.org/wiki/Functional\\_requirement](https://en.wikipedia.org/wiki/Functional_requirement)

<http://www.ofnisystems.com/services/validation/functional-requirements/>

[https://en.wikipedia.org/wiki/Non-functional\\_requirement](https://en.wikipedia.org/wiki/Non-functional_requirement)

## 14.2 Copyright Permission



Yihsuan Lee <yihuan.lee@tp-link.com>

Wed 4/11, 1:27 PM

Adam Althar; Ifiti Anees <ifitianeess@tp-link.com>; Sonia Zhang <sonia.zhang@tp-link.com>; Natasha Han <natasha.han@tp-link.com>



Download Save to OneDrive - Knights - University of Central Florida

Hi Adam,

Thank you for checking with us.

You have the permission to use the product image; however, we ask you not to alter the image in any way and make sure it doesn't look blurry.

The TP-Link logo needs to be added to the image you select, on the top right corner. I've attached a copy for you to use. Other than that, please do not remove or add elements on the image.

Let me know if you have any questions.

Thank you,

Yihsuan

YI-HSUAN LEE

Graphic Designer

Office: 408.818.5474

Skype: yihuan.lee@tp-link.com

TP-Link Research America

Business Development

www.tp-link.com



\*\*\*

## Item Photo Use in Senior Design Paper



Sales <Sales@p3international.com>

Mon 4/9, 4:58 PM

Adam Althar ↵

Good afternoon Adam,

You can use a picture of the Kill A Watt PS10. Thank you for asking and good luck on your senior design report!

Thank you,

Olaedo Ekechukwu

P3 International Corporation

132 Nassau Street

11th Floor – Suite 1103

New York, NY 10038

www.p3international.com

T: (212) 346 7979 Ext 8272

F: (212) 346-9499

E: Ekechukwu@p3international.com

...

[Requests & questions from ti.com] [EXTERNAL] Request for TI block diagram image use in Senior Design Document



Bassuk, Larry <l-bassuk@ti.com>

Fri 4/20, 5:40 PM

Adam Althar ↵

Dear Adam,

Thank you for your interest in Texas Instruments. We grant the permission you request in your email below.

On each copy, please provide the following credit:

Courtesy Texas Instruments

Regards,

Larry Bassuk

Senior Patent Counsel &

Copyright Counsel

Texas Instruments Incorporated

214-479-1152

Permission for photo use in Senior Design Report

 Olivia Proffit <oproffit@google.com>  
Yesterday, 12:31 PM  
Adam Aithar,press@nest.com

Inbox



Download Save to OneDrive - Knights - University of Central Florida

Hi Adam,

Thanks for reaching out. I've attached the high-res version of your requested image to this email. You have permission to use it.

For your reference, all product images can be found on our [press page](#).

Thanks,  
Olivia  
...

### ***Legal Notices***

This document as well as the selection and arrangement of the rules it comprises is Copyright © 2013 by Barr Group. It is permissible for individuals, companies, and institutions to adopt all or a subset of the coding rules herein; indeed we hope that many more will. This may be done simply by identifying the “*Barr Group Embedded C Coding Standard*” as the source of your rules and retaining this paragraph in its entirety. All other rights in copyright law are reserved by Barr Group.

To learn about acquiring the rights to an editable (e.g., Microsoft Word format) version of this coding standard to adapt to your needs, please call (866) 65-EMBED or email [embed@barrgroup.com](mailto:embed@barrgroup.com).

Barr Group and the Barr Group logo are registered trademarks of Integrated Embedded, LLC. Other trademarks used in this book are property of their respective owners.