

# Bioelectric Smartwatch



## Group 1

Krystal Folkes

Computer Engineering

Jelani Foy

Electrical Engineering

Bailey Morgan

Electrical Engineering

Niabelle Thelemaque

Electrical Engineering

## **Special Thanks**

We would like to thank Dr. Ricardo Zaurin for suggesting the original senior design idea of a watch/bracelet with accelerometers and a system that recognizes the vibration patterns for people like his mother, suffering from Parkinson's disease.

Our senior design process requires each person to contribute 30 independent ideas. Then each group of four students had to evaluate around 100 ideas and select one or two. After that, the teams needed to write 10 pages for 1 or 2 ideas. A watch for people with Parkinson's disease was one of the ideas we submitted. During our half-hour meeting, Dr. Wei pointed out the difficulty to differentiate Parkinson's-related vibrating movements from vibrating movements while walking. Dr. Wei pointed out certain difficulties in determining if someone fell on the ground or just dropped the watch on the ground. As a result, we added two sensors: one to measure pulse and one to measure body temperature. This is how this project idea developed.

Ms. Krystal Folkes also would like to express her appreciation to Dr. Wisniewski for two independent studies and one summer REU opportunity. Our team was made aware of Dr. Wisniewski and her team's NSF funded project for Carebit, a health monitoring app, similar to our project. Her project is to do a feasibility study.

## Table of Contents

Special Thanks .....	ii
List of Figures .....	viii
List of Tables .....	x
1.0 Executive Summary .....	1
2.0 Project Description.....	2
2.1 Goals and Objectives.....	2
2.2 Project Specifications .....	3
2.3 Marketing Trade-off Matrix .....	4
3.0 Research .....	5
3.1 Existing Products.....	5
3.1.1 Fitbit.....	5
3.1.2 Life Alert .....	6
3.1.3 Apple iWatch.....	6
3.1.4 Garmin Forerunner and Chest Strap.....	7
3.2 Skin Temperature Sensor .....	8
3.2.1 Resistance Temperature Detector (RTD) .....	8
3.2.2 Thermocouple .....	9
3.2.3 Thermistor .....	10
3.2.4 Temperature Sensor Integrated Circuit.....	10
3.3 Voltage Regulator .....	12
3.3.1 Linear Voltage Regulator .....	12
3.3.2 Switching Voltage Regulator.....	12
3.4 Data Converters.....	14
3.4.1 Comparison of Data Converters .....	14
3.5 Microcontroller.....	15
3.6 Electronic Housing.....	17
3.6.1 3D Printed Case .....	17
3.7 Display .....	18
3.7.1 Display Performance .....	18
3.7.2 Display Cost .....	19
3.7.3 Display Power Requirements .....	20

3.8 Battery .....	20
3.8.1 Power Capacity .....	21
3.9 Power Management .....	23
3.9.1 Energy Harvesting .....	24
3.9.2 Conventional Battery Charging .....	24
3.9.3 Wireless Charging .....	24
3.10 Battery Fuel Gauge.....	25
3.11 Push Buttons.....	28
3.12 Pulse Sensor .....	29
3.12.1 Electrocardiogram .....	29
3.12.2 Pulse Oximetry .....	30
3.13 Accelerometer .....	33
3.13.1 Capacitive Accelerometers .....	34
3.13.2 Piezoelectric Accelerometers .....	35
3.13.3 Accelerometer Comparison .....	35
3.14 Vibrating Motor.....	36
3.14.1 Motor Control Circuit.....	37
3.15 Printed Circuit Board .....	37
3.16 Watch Band.....	38
3.17 Bluetooth.....	38
3.17.1 Bluetooth Protocols .....	39
3.17.2 Bluetooth Range .....	39
3.17.3 Bluetooth Pairing.....	40
3.17.4 Bluetooth Security .....	41
3.18 Global Positions System (GPS) .....	41
3.18.1 GPS Background .....	41
3.18.2 Application of GPS.....	42
3.18.3 GPS Alignment and Structure .....	42
3.18.4 GPS Mapping Software .....	43
3.18.5 GPS An Inside Look.....	45
3.18.6 GPS Trilateration.....	45
3.18.7 GPS Error Boundaries .....	46

3.19 Wireless Local Area Networking (Wi-Fi).....	47
3.19.1 Wi-Fi Background .....	47
3.19.2 Wi-Fi Security .....	52
3.20 Diodes.....	52
3.21 Ordered Components.....	57
3.22 Senior Design 2 Changes .....	58
3.22.1 Temperature Sensor .....	58
3.22.2 Voltage Regulator.....	58
3.22.3 Push Buttons .....	58
3.22.4 Accelerometer.....	58
3.22.5 Data Converter.....	58
3.22.6 Microcontroller .....	59
3.22.7 Watch Shell and Band .....	59
3.22.8 Wireless Local Area Networking (Wi-Fi).....	59
4.0 Related Standards and Design Constraints (IEEE).....	60
4.1 Related Standards.....	60
4.1.1 IEEE Health Informatics .....	60
4.1.2 IEEE Recommended Practice for General Principles of Temperature Measurements as Applied to Electrical Apparatus .....	61
4.1.3 IEEE Standard for Rechargeable Batteries for Portable Computing.....	62
4.1.4 Definitions and Concepts for Dynamic Spectrum Access.....	65
4.1.5 Software Life Cycle Processes .....	65
4.1.6 Systems Life Cycle Processes .....	65
4.1.7 IEEE Standard for Sensor Performance Parameter Definitions .....	66
4.1.8 IEEE Bluetooth Standard.....	67
4.1.9 NASA Standard for Soldering .....	67
4.1.10 IEEE Wireless Local Area Network Assisted GPS in Seamless Positioning.....	67
4.1.11 PCB Standard .....	68
4.1.13 Health Informatics Personal Health Device - 11073-10404-2010 .....	69
4.2 Design Constraints .....	70
4.2.1 Economic and Time Constraints.....	71
4.2.2 Environmental, Health and Safety Constraints.....	71
4.2.3 Ethical and Social Constraints .....	72

4.2.4 Electrical Safety Constraints .....	72
5.0 Project Design.....	73
5.1 Motor Design.....	73
5.2 Power Design .....	74
5.2.1 Power Consumption .....	75
5.2.2 Battery and Charging Design .....	77
5.2.3 Voltage Regulator Design .....	78
5.3 Pulse Sensor Design .....	78
5.4 Accelerometer and Temperature Design.....	80
5.4.1 Accelerometer GPIO PIN Description .....	81
5.5 Bluetooth Communication Design .....	83
5.5.1 Bluetooth GPIO PIN Descriptions .....	83
5.5.2 BlueFruit LE Hardware Technical Specification .....	84
5.6 GPS Design .....	85
5.6.1 GPS GPIO PIN Descriptions .....	85
5.6.2 GPS Hardware Technical Specification .....	86
5.7 OLED Display Design Schematic.....	87
5.7.1 OLED Display GPIO PIN Descriptions .....	88
5.7.2 OLED Display Hardware Technical Specification .....	89
5.8 Switch Design .....	90
5.9 Hardware Design.....	91
5.9.1 General Layout .....	91
5.9.2 Watch Shell.....	93
5.9.3 Watch Shell Change in Senior Design 2 .....	94
5.10 Overall Design.....	94
5.10.1 PCB Schematic .....	96
6.0 Software Design.....	97
6.1 Software Framework Ionic.....	97
6.2 Ionic Framework Setup.....	97
6.3 Ionic Framework Running Application Through Browser vs Native Platforms .....	97
6.4 Running Application on the Simulator vs Physical Device .....	98
6.5 Software Definitions, Acronyms, and Abbreviations .....	99

6.5.1 Software Life Cycle Process.....	99
6.6 Software Assumptions.....	99
6.7 Storing Application with Version Control Systems.....	100
6.8 Common GitHub Features .....	100
6.9 Software Event Table .....	101
6.10 Software User Interface Mobile .....	102
6.11 Software Testing Mobile.....	103
6.12 Software Individual Test Cases Mobile .....	104
6.13 Software Security .....	105
6.14 Senior Design 2 Software Update .....	106
7.0 System Testing.....	107
7.1 Motor Testing.....	107
7.2 Power Testing.....	108
7.2.1 Battery and Battery Charger Testing .....	109
7.2.2 Voltage Regulator Testing.....	109
7.3 Bluetooth Testing .....	110
7.4 GPS Testing.....	112
7.4.1 GPS Device Receive Data Test .....	112
7.4.2 BlueFruit LE UART Device Powered by Battery Test Combined .....	114
7.5 OLED Display Testing.....	115
7.5.1 OLED Display Test .....	115
7.6 Accelerometer Testing .....	117
7.6.1 Accelerometer Test.....	117
7.7 Pulse Sensor Testing .....	117
7.7.1 Pulse Sensor Test.....	117
7.8 Pushbutton Testing.....	118
7.9 Overall System Testing .....	119
7.10 Overall System Testing in Senior Design 2 .....	119
8.0 Administrative Content.....	120
8.1 Initial Project Diagram .....	120
8.2 Budget .....	121
8.2.1 Components of final PCB.....	122

8.3 Project Milestones .....	122
9.0 Conclusions .....	124
9.1 Possible Future Considerations .....	124
10.0 Appendices .....	126
10.1 Bibliography .....	126
10.2 Requested Permissions .....	131
10.3 Copyright Permissions .....	138

## List of Figures

Figure 1: Image of Wearable Fitbit .....	5
Figure 2: Different Wearable Options for Life Alert System .....	6
Figure 3: Apple iWatch PPG .....	7
Figure 4: Garmin Forerunner 630 and Garmin Chest Strap .....	7
Figure 5: Design of RTD .....	9
Figure 6: Schematic of Thermocouple .....	9
Figure 7: Simple Diagram of Temperature Sensor Integrated Circuit .....	10
Figure 8: Basic Diagram of Linear Voltage Regulator (Courtesy of Microelectronics) .....	12
Figure 9: Basic Diagram of Switching Voltage Regulator .....	13
Figure 10: Image of Basic layout of a Microcontroller .....	16
Figure 11: Visualization Comparison of the OLED Display vs. LCD Display .....	19
Figure 12: Power Capacity Watt-hour Formula .....	22
Figure 13: Battery Connection Schematic Example .....	22
Figure 14: Battery Capacity Reduction Graph .....	23
Figure 15: Inductive Power Transmission Theoretical Display .....	25
Figure 16: Visualization of Wireless Charging Process .....	26
Figure 17: High-Level Visualization of Battery Fuel Gauge Process .....	27
Figure 18: Light Emitting Diode Fuel Gauge Circuit Example .....	28
Figure 19: Push Button Operation Illustration .....	29
Figure 20: Pulse Oximetry Illustration .....	30
Figure 21: High-Level PPG Sensor Diagram .....	31
Figure 22: High-level LED Controller Diagram .....	31
Figure 23: H Bridge Driver Design for LEDs .....	31
Figure 24: AFE4400 Design .....	32
Figure 25: Single Capacitive Accelerometer Diagram .....	34
Figure 26: Differential Capacitive Accelerometer Diagram .....	34
Figure 27: Diagram of Piezoelectric Technology .....	35
Figure 28: Motor Control Circuit .....	37



Figure 29: Bluetooth Protocol Stack.....	39
Figure 30: General Satellite with Antenna.....	42
Figure 31: Sample of GPS Satellites Orbiting Earth .....	43
Figure 32: Diagram Roadmap of Bluetooth Connection .....	44
Figure 33: General Internal Components of GPS .....	45
Figure 34: GPS Trilateration Configuration .....	46
Figure 35: Illustration of Wi-Fi with Connected Devices .....	50
Figure 36: The Voltage and Current Relationship of an Ideal Diode .....	53
Figure 37: Voltage and Current Relationship of an Applicable Diode.....	54
Figure 38: Voltage and Current Relationship of a Zener Diode.....	54
Figure 39: Voltage and Current Relationship of an LED .....	55
Figure 40: Voltage and Current Relationship of a Schottky Diode .....	55
Figure 41: Smartwatch Ordered Components.....	57
Figure 42: Image of Temperature Measurement Characteristics.....	63
Figure 43: Formal Soldering Technique .....	67
Figure 44: SPI Standard Demonstration .....	69
Figure 45: I2C Standard Demonstration .....	69
Figure 46: Motor Schematic .....	73
Figure 47: Power Block Diagram .....	75
Figure 48: Battery Charging Design Schematic .....	77
Figure 49: Pulse Sensor Communication Diagram.....	79
Figure 50: Pulse Sensor Schematic.....	79
Figure 51: Data flow diagram of LIS3DH.....	80
Figure 52: Accelerometer and Temperature Sensor Schematic.....	81
Figure 53: Bluetooth and Microcontroller Schematic .....	85
Figure 54: GPS and Microcontroller Schematic.....	86
Figure 55: Display Design .....	87
Figure 56: OLED and Microcontroller .....	89
Figure 57: Switch Connection Diagram .....	91
Figure 58: Simple Switch Test Schematic .....	91
Figure 59: The general physical layout of the smartwatch prototype. Frontal view (left), back view (right).....	92
Figure 60: Layout of Watch Shell Prototype .....	93
Figure 61: Layout of Watch Shell.....	93
Figure 62: Figure of Overall System Schematic.....	95
Figure 63: Final PCB Schematic .....	96
Figure 64: Agile Software Development Software.....	100
Figure 65: Mobile App Prototype Layout.....	102
Figure 66: Raspberry Pi 3 Microcontroller.....	107
Figure 67: Supply voltage and base voltage of vibrating motor circuit.....	108

Figure 68: Motor Breadboard Testing .....	109
Figure 69: Image of Voltage Regulator attached to Power Supply .....	110
Figure 70: BlueFruit LE UART Wiring for Raspberry Pi .....	111
Figure 71: Bluetooth outputting “Hello World” to the terminal.....	111
Figure 72: Bluetooth Discoverable to Mobile Device .....	112
Figure 73: GPS UART Wiring for Raspberry Pi .....	113
Figure 74: GPS Component Receiving Data .....	113
Figure 75: Verified the location coordinates given by GPS are accurate .....	114
Figure 76: Bluetooth Powered with Battery and Voltage Regulator .....	115
Figure 77: OLED Display Wiring to Raspberry Pi.....	116
Figure 78: OLED Display demonstration executing shapes.py.....	116
Figure 79: Accelerometer outputting three-directional axis to the terminal.....	117
Figure 80: Pulse Sensor output to Terminal .....	118
Figure 81: Push Button Breadboarding.....	118
Figure 82: Block Diagram of Assigned Roles .....	120
.....	122
Figure 83: PCB with soldered components .....	122

## List of Tables

Table 1: Legend for House of Quality Diagram .....	4
Table 2: House of Quality Diagram.....	4
Table 3: Comparison of Techniques to Measure Skin Temperature .....	11
Table 4: Comparison of Integrated Circuit Temperature Sensor.....	11
Table 5: Comparison of Linear and Switching Voltage Regulators .....	13
Table 6: Comparison of Voltage Regulator Components.....	14
Table 7: Comparison of Data Converters .....	15
Table 8: Comparison of Microcontrollers.....	16
Table 9: Comparison of 3D Printed Material .....	17
Table 11: Overall Display Comparison .....	20
Table 12: Battery Advantages and Disadvantages.....	21
Table 13: Battery Logistics Comparison .....	23
Table 14: Battery Charge Color Indication Levels .....	27
Table 15: Push Button Quick Facts .....	29
Table 16: Comparing AFE4400 and AFE4490 Pulse Oximetry Analog Front Ends.....	33
Table 17: Comparison of 3 Different Accelerometers.....	36
Table 18: Bluetooth Versioning Comparisons.....	40
Table 19: Comparison of 2 Different GPS Modules .....	48
Table 20: Comparison of 2 different Wi-Fi .....	51
Table 21: Comparison of Different Types of Diodes .....	56

Table 22: Comparison of 2 Diodes .....	56
Table 23: Device current consumption .....	75
Table 24: Battery Charger Indicators.....	78
Table 25: Accelerometer GPIO Pin Mappings to Raspberry Pi .....	82
Table 26: Bluetooth GPIO mapping to Raspberry PI.....	84
Table 27: GPS Raspberry Pi 3 GPIO Mapping .....	86
Table 28: Display Raspberry Pi 3 GPIO Mapping .....	89
Table 29: Software Events for Testing .....	102
Table 30: Data Extraction Comparison Methods for Smartwatch Devices.....	106
Table 31: Voltage Regulator Preliminary Test .....	110
Table 32: Project Budget Table .....	121
Table 33: Senior Design 1 Projected Schedule.....	123
Table 34: Senior Design 2 Projected Schedule.....	123

# 1.0 Executive Summary

Health has always been an important topic in our society. However, the exact definition of health has constantly changed over time. Before, being healthy just meant that a person did not have any type of disease. It wasn't until the late 1980s that the World Health Organization, an organized agency of the United Nations that focuses on setting norms and standards, policies, and providing leadership on matters related to public health, defined health as "the extent to which an individual or group is able to realize aspirations and satisfy needs, and to change or cope with the environment. Health is a resource for everyday life, not the objective of living; it is a positive concept, emphasizing social and personal resources, as well as physical capacities."

People are always monitoring their health, whether it is in the form of doctor check-ups, paying attention to nutrition, or going to the gym. With innovations in technology, tracking health progress has become easier as gadgets can provide statistics and tips based on real-time trends and scientific studies. We wanted to create a product that not only contained many health features to track health progress but also serve as an alert system in times of distress. There are already fitness trackers in the market, and there are already distress signal beacons for elderly people. The idea behind the Bioelectric Smartwatch is to integrate both the lifestyle improving characteristics of a smartwatch and an emergency GPS beacon.

The Bioelectric Smartwatch is a small electrical current device that has the capabilities of monitoring a person's vitals based on their inputted health profile and send notifications or alerts to specified personnel in the event of a medical emergency. The Bioelectric Smartwatch will be able to collect and send data wirelessly to a safe and secure mobile web application. The user will also have the ability to allow or deny the supervisory to their medical professional or family members. The smartwatch will also have the ability to display helpful information and notify users through the use of vibrations, and visual LED interface. By doing this, we are providing aid with new age medical technologies, contributing to society, and helping in the physical therapy practices.

The Bioelectric Smartwatch is tailored towards elderly people, or people with an illness that needs to be tracked. The watch will have the ability to send a signal in the event of an emergency that will notify local authorities of the user's location. Being that older people and people with certain medical conditions are more at risk for accidents, having the ability to track vitals and send out an emergency GPS signal will help save lives. To help improve the life of the user, the pulse and temperature, and step count will help track their exercise. Increasing exercise is a key factor to living a healthier lifestyle. The Bioelectric Smartwatch's purpose is to assist elderly and sick people to get on track to living a healthy lifestyle, and maintaining a healthy lifestyle if they are already living a healthier lifestyle. While being tailored towards the elderly, this watch can also be marketed towards the general public.

## **2.0 Project Description**

The Bioelectric Smartwatch is to have a small microcontroller PCB. This small microcontroller should have the capability to monitor and detect client's health with integrations of many vital body sensors. For example, a Parkinson's client that may have the possibility of having one type of motor function such as the rhythmic spontaneous resting discharge may need the accelerometer feature of the watch to monitor the speed of hand muscle contractions and the body impedance to send notification to user to notify them that they are experiencing a tremor. The accelerometer will measure the hand movement, and send data wirelessly.

The pulse sensor of the device will contain an infrared emitter and receiver. The emitter sends infrared light through the skin, and the emitter acts like a solar cell, absorbing the light that is reflected by the body. The emitter turns the infrared light into electrical signals that are then amplified. The changing blood flow through a vein will reflect different amounts of infrared light, thus the emitter will be seeing spikes that can be interpreted as a pulse. The analog signal from the body is filtered. After filtering the signal, the pulse can then be output to the user in beats per minute (BPM).

Skin temperature can be implemented using a thermistor, a type of resistor that changes resistance based on its temperature. This component will be integrated into the smartwatch to directly make contact with the user's skin. The thermistor will be able to aid in the measurement of a person's electro-dermal activity, also known as skin conductance, which is activated by an increase in sweat gland activity.

Data from these tests will be sent wirelessly to a monitoring device web platform (smart device, computer, etc....) to help with, collecting data of progress and be used to help medical professionals. The mobile web platform will be secure and make sure the privacy of the user medical records is not compromised. A GPS system will also be integrated with the watch to track the user's location that will communicate to client's mobile device. In the event of an emergency, the user will be able to send a distress signal that will help authorities pinpoint their location.

### **2.1 Goals and Objectives**

The Bioelectric Smartwatch works toward essentially being a hub for health and a monitor of a person's health conditions. The objective of this project is to create a smartwatch that can be used by sick and elderly. A user will be able to create an online health profile to specify any type of health conditions they may be suffering from. For example, customers with Parkinson's and anxiety and high stress. Some of the health conditions that we will factor into the watch include measuring pulse, skin temperature, movement. Furthermore, this apparatus will utilize a mobile web application capability to store private information that can be used for medical records and progress. Additionally, this information can be securely sent to approved family and medical personnel. The smartwatch mobile web application will be able to send out alerts and notifications to specified authorized personnel, when there is need for medical or considered high risk situation for the client.

## 2.2 Project Specifications

- Watch Shell
  - 10cm x 7cm
    - Prototype will be larger than actual product after integrating components into a chip
  - Weighs under ½ lb
  - Will have a wrist strap
    - Wrist strap will be universal fitting wrist strap for any user
  - Will be comfortable for the user
  - Will contain an LCD screen
    - Will be able to read pulse
    - Will be able to read steps taken
    - Will be able to navigate through menus
    - Will be able to read the screen at night
    - Will have the time
  - Will contain a Lithium battery to power the watch
    - Will supply 3.7V DC to the microcontroller via a power supply circuit
    - Will be charged from a power outlet via a cord
  - Will have buttons to navigate menus
  - Will have a motor that alerts user
    - Motor will be controlled via transistor
- Accessibility
  - Will be lightweight
  - Will be portable
- Wireless Communication
  - Can send and receive data up to 50ft.
  - Measurement and control information send and receive accurately to web-based application
- GPS Signal
  - Can detect user location with 90% accuracy
- Measurements
  - Will be able to measure user's pulse within +/-3 beats per minute
  - Will be able to measure user's movement within +/- .1g
  - Will be able to measure user's position within +/- 50ft.
- Smartwatch features
  - Measure amount of steps taken
  - An alert button to notify authorities
  - Measure pulse

## 2.3 Marketing Trade-off Matrix

A House of Quality Diagram is a diagram that helps determine how a product will meet a customer's need. This diagram, seen in Table 2, was used to help determine some important tradeoffs and marketing requirements. Some things that were considered were predictions of the customers' expectations and what aspects they would be looking for when considering our product. A legend explaining the symbols that were used can be seen in Table 1.

**Table1: Legend for House of Quality Diagram**

Legend	
↑	Positive Correlation
↓	Negative Correlation
+	Positive Polarity (Increasing the Requirement)
-	Negative Polarity (Decreasing the Requirement)
Blank spaces mean no correlation	

**Table 2: House of Quality Diagram**

		Watch Dimensions	Adaptability	Weight of Device	Accuracy in measurements	Battery Size
		-	+	-	+	-
<b>Small Size</b>	-	↑	↑	↑	↓	↑
<b>Low Cost</b>	-	↑	↓	↑	↑	↑
<b>Easy to Use</b>	+	↓	↑	↑	↑	
<b>Long Battery Life</b>	+	↑	↓	↓	↓	↓
<b>Durable</b>	+	↑	↑	↑	↑	↑
<b>Targets for Engineering Requirements</b>		<b>10cm x 7cm</b>	<b>Covers at least two user cases</b>	<b>&lt; ½ lb</b>	<b>&gt; 95%</b>	<b>&lt; ¼ lb</b>

## 3.0 Research

This section gives an overview on the research and background information implemented when designing and creating the Bioelectric Smartwatch. Included in this section are as follows:

- Information on existing products
- An overview of the research done in picking components
- Technology used for the Bioelectric Smartwatch's features

Analysis was done on the different methods to best meet the Bioelectric Smartwatch needs and the advantages and disadvantages of the potential components were considered.

### 3.1 Existing Products

Monitoring one's health has increased in popularity as people focus on their well-being. With these new health trends and diets emerge, devices in the market are geared to include ways to track their activity. This section discusses and reviews pre-existing and/or similar products where some of the attributes were included or improved on in the Bioelectric Smartwatch.

#### 3.1.1 Fitbit

The Fitbit is an activity tracker and wireless enable device. It can measure a variety of personal metrics related to a person's fitness like quality of sleep, number of steps walked, and heart rate. Most of the Fitbit products can be worn on the wrist. There is also a mobile app and website that Fitbit users can use to log in calorie consumed and burned, track their progress over time, and set goals for themselves. The Fitbit also includes a USB to sync data to the mobile app and website. Fitbit also offers their products in a range of designs and colors so that users can customize their Fitbit to their liking.



**Figure 1: Image of Wearable Fitbit**  
Courtesy of <http://help.fitbit.com/?cu=1&form=pr>

Although this product is widely popular, it comes with a few criticisms. One major



criticism is privacy concerns. Although Fitbit has its own account set-up, there was an issue with the website with their user's descriptions of and inputted information was available for the public to view. Another issue is the cost of the Fitbit. Since the market is a competitive atmosphere, many other devices offer similar services that the Fitbit must offer, but at a cheaper cost.

### 3.1.2 Life Alert

Known for its catchy slogan, I've fallen and I can't get up! ®, Life Alert is a small wireless help button that a user wears at all times. in the event of a medical emergency. This device is geared toward someone who is handicapped or elderly person. If they are in trouble, the user can press the button on the pendant which acts as an automated dialer that is connected to a telephone line. The pendant serves as a speakerphone so that the emergency dispatcher can alert authorities of the issue at hand. Some of the Life Alert's features are that the device is waterproof, has 800ft range, and has a battery life up to 7-10 years (Website).



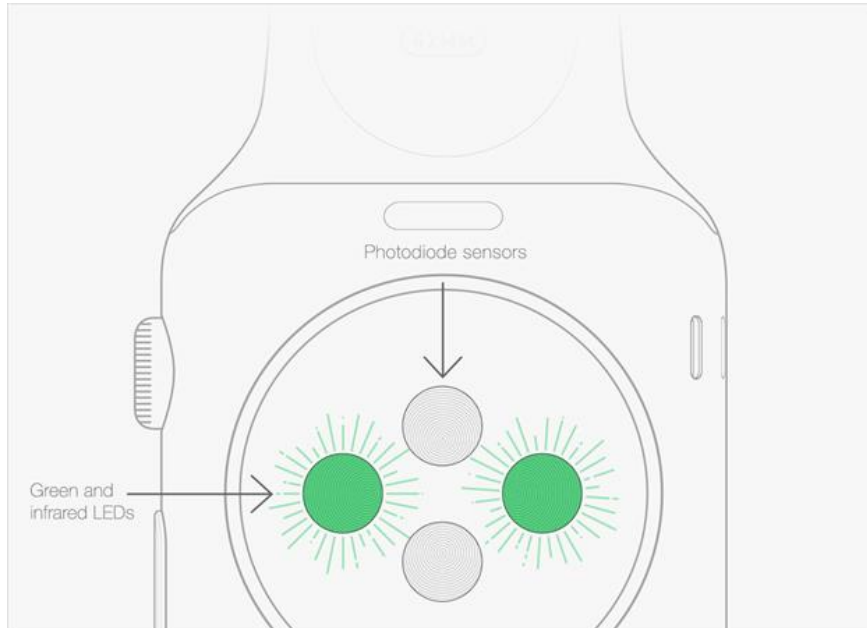
**Figure 2: Different Wearable Options for Life Alert System**  
Courtesy of <http://www.lifealert.com/>

The biggest issue facing the Life Alert system is its reputation in society. Although the commercials for the Life Alert system are informative and serve as a reminder of the importance of the device, many potential users are dissuaded from buying the product because of its stigma. It has been mocked on social media and television. Another drawback to this system is its design. Although, the pendant can be worn on the wrist or around the neck, the design of the pendant itself is bland. Reviews have stated that Life Alert was a reliable system; however, it's not the best option for people who have active lifestyles.

### 3.1.3 Apple iWatch

Apple watch uses PPG to measure its user's pulse. It makes use of LEDs that are both Green, and infrared light. Blood absorbs green light very well, thus the green is a better indicator. The infrared light is used when the user is sleeping. Photodiodes measure the amount of light absorbed by the blood to see how the blood is flowing. The apple watch

can also connect to a chest strap, that can measure the BPM of the heart by EKG, which is more accurate. Other watch manufacturers use the same method to get the user's pulse, including Fitbit, Garmin, and Polar.



**Figure 3: Apple iWatch PPG**  
Courtesy of <https://support.apple.com>

### 3.1.4 Garmin Forerunner and Chest Strap



**Figure 4: Garmin Forerunner 630 and Garmin Chest Strap**  
Courtesy of <https://www.bike-discount.de>

The Garmin Forerunner series is used by fitness enthusiasts that use heart rate to improve their workouts. Newer Garmin Forerunners also include PPG, but may communicate to an external chest strap via Bluetooth for improved accuracy. The chest strap utilized

Electrocardiography (ECG), to more accurately measure the heart rate of the user while they are more active. Other fitness watches can communicate to an external chest monitor like the abovementioned, but for our design it is not necessary because this watch is not intended for fitness purposes.

## **3.2 Skin Temperature Sensor**

The skin is the largest organ of the body. It protects our body from external elements, regulates our internal temperature, and helps produce necessary vitamins. A person's average internal temperature is 37°C (98.6°F); however, internal temperatures can vary due to the outside environment. Internal temperatures can also vary due to a person's health. Because of these fluctuations in temperature, medical professionals pay special attention to temperature because it can be an indicator of any health problems. There are many ways to measure skin temperature but the most accurate method are internal measurements or in a body cavity. An example can be seen when doctors measure a person's temperature in the tympanic membrane, also known as the eardrum.

A traditional thermometer works with the thermal expansion or contraction of fluids with respect to temperature changes. Usually the fluid used is mercury because it grows bigger when heated and smaller when cooled. It's measuring range is -37-356°C (-34.6-672.8°F), unlike earlier methods that used water which freezes at 100°C (32°F). When the material is heated, or loses heat, it must reach its final pressure in order to obtain an official final temperature. In heated materials, the liquid in most of the thermometers is forced to rise, either going up or down.

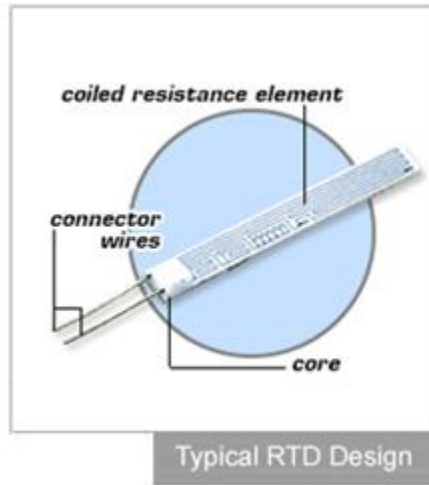
The Bioelectric Smartwatch will measure skin temperature on the wrist. Due to its placement, there will be loss in accuracy. When measuring skin temperature on different parts of the body, it must satisfy a set of standards, known as the "Golden Standard" (Please refer to section 4). There are many types of components and methods to measure skin temperature in the market; however, we narrowed our search to focus on digital thermometers. Within this category the following have been considered:

- Resistance temperature detectors (RTD)
- Thermocouples
- Thermistor
- Temperature sensor integrated circuit

### **3.2.1 Resistance Temperature Detector (RTD)**

Resistance Temperature detectors are detectors that sense temperature by using the change in resistor values to calculate temperature. The relationship between resistance and temperature is described as the change in resistance of the sensor per temperature degree change. An RTD probe is designed by wrapping a fine-coiled wire around a ceramic core. A pure resistance element, usually platinum, nickel, or copper, is used to best determine temperature. This device can be easily placed on the bottom of the Bioelectric Smartwatch

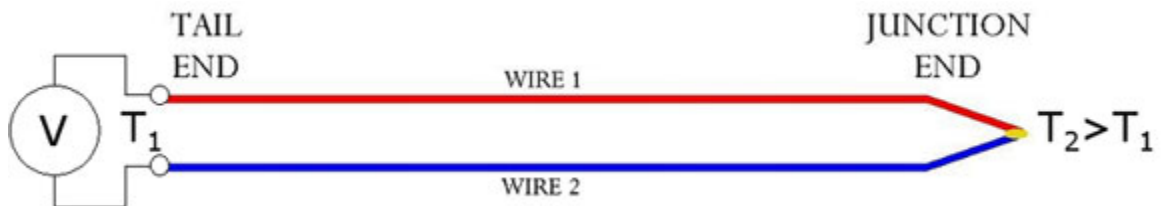
so that it can direct contact the user's skin. The main issue with this detector is that the price for this component is expensive.



**Figure 5: Design of RTD**  
 Courtesy of <http://www.omega.com/prodinfo/rtd.html>

### 3.2.2 Thermocouple

Thermocouples are temperature sensors that are very sensitive to changes in temperature. A thermocouple has two metal elements that form two junctions. One junction is used as a reference while the other junction is connected to the unknown body temperature. With these two junctions, the unknown temperature is measured in reference to the known temperature. The thermocouple works when the two wires are joined at both ends, a continuous flow of current flows and when this circuit is broken, the voltage produced is correlated to the temperature. The image in Figure 6 below shows the schematic for a typical thermocouple design. This image shows the two wires at different temperatures, one ambient temperature and the other at a higher temperature. A voltage difference between the two wires was measured and found using the equation below, In this equation.  $S_1$  and  $S_2$  are the Seebeck coefficients of the two elements, which can be found using online reference tables.



**Figure 6: Schematic of Thermocouple**  
 Courtesy of <https://www.msm.cam.ac.uk>

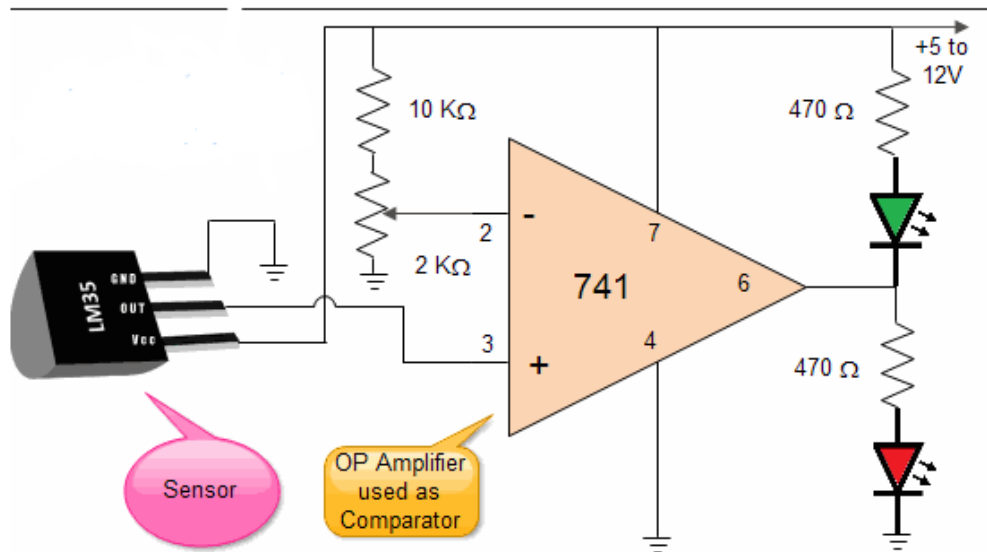
$$EMF = \int_{t_1}^{t_2} S_{12} \cdot dt = \int_{t_1}^{t_2} (S_1 - S_2) \cdot dt$$

### 3.2.3 Thermistor

A thermistor is a semiconductor device that measure temperature using electrical resistance. They are usually made from ceramic or polymer. The resistance of a thermistor will change with the change in temperature and temperature and resistance have a nonlinear relationship. Due to its size, it quickly responds to any temperature changes.

### 3.2.4 Temperature Sensor Integrated Circuit

An integrated circuit temperature sensor is a two-terminal integrated circuit temperature device that produces an output current. This output current is then used in proportion to absolute temperature. With integrated circuit like this temperature sensor, there is extensive signal processing circuitry included, enabling the use of lesser parts. Temperature is also measured continuously. The Figure below shows a schematic of a simple temperature sensor integrated circuit that houses an internal operational amplifier. The internal amplifier acts as a comparator to measure the differences in a reference voltage and the temperature of the unknown material/ object. The diodes aid in the measurement of the actual temperature sensor. The voltage drop across the diodes depend on temperature to operate. All of these components are internalized into an integrated circuit component such as the LM35. Further studies will be conducted to determine the best component for the Bioelectric Smartwatch.



**Figure 7: Simple Diagram of Temperature Sensor Integrated Circuit**  
Courtesy of <https://www.omega.com>

Table 3 shows a comparison of the four different types of methods that skin temperature can be measured. Some of the similar characteristics for the different types of methods were weighed against each other.

**Table 3: Comparison of Techniques to Measure Skin Temperature**

Type	RTD	Thermocouple	Thermistor	IC Temp Sensor
General Temperature Range	-260-750 °C	-180-1480 °C	-50-300 °C	-55-150 °C
Accuracy	Most accurate	Variation between models	Depends on model	Wide variation between models
Input/ Output Power	High power	High power	Low power	Low power
Linearity	Nonlinear	Non-linear	Non-linear	Linear
Cost	Expensive	Can be expensive	Can vary	Cheapest

**Table 4: Comparison of Integrated Circuit Temperature Sensor**

Name	LMT70	MAX6613
Supplier	Texas Instruments	Digi-Key
Temperature Range	-55-150°C	-55-130°C
Accuracy	±0.05°C or ±0.13°C from 20°C to 42°C	±4.0°C from 0°C to 50°C
Size	0.88mmx0.88mm	Not given
Cost	\$0.80	\$0.86

From research and comparisons, using an integrated circuit temperature sensor will meet the requirements of the Bioelectric Smartwatch.

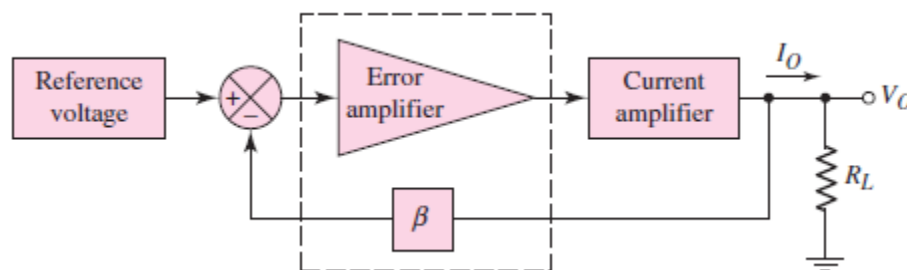
Based on research comparison on the two components, the LMT70 was chosen for the Bioelectric Smartwatch because it has a better accuracy and is slightly cheaper than the MAX6613.

### 3.3 Voltage Regulator

Voltage regulators are designed to maintain a constant voltage level automatically. They prevent the occurrence of damaging surges and provide enough voltage that is required for a device to work. There are two types of voltage regulators: linear and switching.

#### 3.3.1 Linear Voltage Regulator

A linear voltage regulator controls the voltage drop between the input and output to keep the output voltage constant or at a desired value. A simple linear voltage regulator can be made using a transistor and an operational amplifier to perform output regulation. However, to simplify components and due to spacing constraints from the size of the actual watch, a voltage regulator component will be used. Linear voltage regulators are required to have a higher reference voltage than the output voltage because the output voltage is derived from the reference voltage.

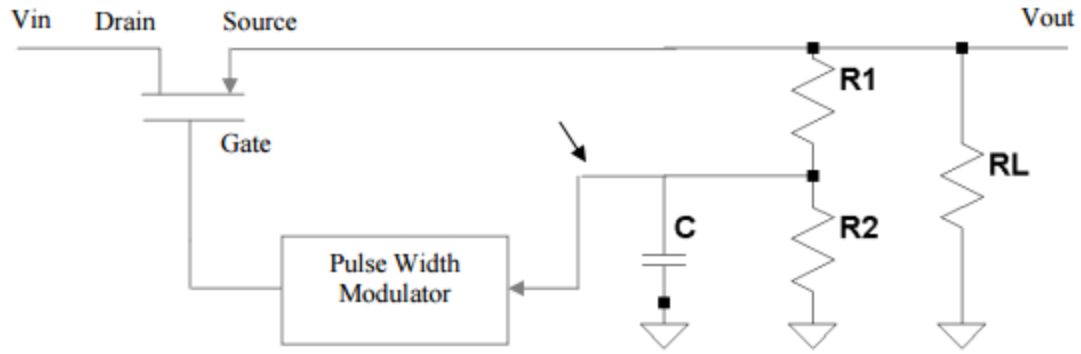


**Figure 8: Basic Diagram of Linear Voltage Regulator (Courtesy of Microelectronics)**  
**Courtesy of Microelectronics Circuit Analysis and Design**

The image in Figure 8 shows a basic schematic of a linear voltage regulator. The portion encased by the dotted lines make the feedback loop. Part of the output voltage goes back into this feedback loop to ensure that the feedback is equal to the reference voltage, thus acting as a regulator. One main concern of the linear voltage regulator is that it may cause a device to overheat because of the large amount of energy dissipation. This can be an issue for the Bioelectric Smartwatch because users must be able to wear the watch comfortably, and safely, without worrying about being burned.

#### 3.3.2 Switching Voltage Regulator

Switching voltage regulators are regulators that vary its duty cycle to rapidly switch a device on and off to maintain a constant output voltage. If the output voltage gets too high, energy flow is cut while energy flow is taken from the input if the output voltage is too low. The use of capacitor and inductors are also used for energy storage purposes.



**Figure 9: Basic Diagram of Switching Voltage Regulator**  
 Courtesy of <http://www.ece.ucf.edu>

The image in Figure 9 shows a basic diagram of a switching voltage regulator. A simple switching voltage regulator usually has a MOSFET and a pulse width modulation. A pulse width modulation is a modulation technique that controls power to electrical devices and loads while the MOSFET controls the flow of voltage. The capacitor in the diagram serves as a storage element, storing the peak voltage. The capacitor can also serve as a DC source voltage even when the output voltage is at a higher voltage.

**Table 5: Comparison of Linear and Switching Voltage Regulators**

Type	Linear Voltage Regulator	Switching Voltage Regulator
Relationship between input and output	Input is higher than output	Output can be higher than input
Ease of use	Simple	Complex
Efficiency	50% or <	70-90%
Cost	Inexpensive	Can be expensive

To fit the purposes of the Bioelectric Smartwatch, a switching voltage regulator will be used. Three types of voltage regulator have been reviewed to determine the most applicable to the project. They are the TPS61200 voltage regulator, the U1V11F3, and the 102-27758-ND. Table 6 shows the comparison of the three voltage regulators. Based on the research and comparison, the best voltage regulator for the Bioelectric Smartwatch is the U1V11F3.



**Table 6: Comparison of Voltage Regulator Components**

Name	TPS61200	102-2758-ND Also, known as PDS1-S5-S5-S	U1V11F3
Supplier	Texas Instruments	Digi-Key	Pololu
Max current	600 mA	200 mA	1.2 A
Max voltage	5.5 V	5.5 V	5.5V
Min voltage	0.5 V	4.5 V	0.5 V
Price of 1	\$4.49	\$4.31	\$4.95

### 3.4 Data Converters

With the features that will be included in the Bioelectric Smartwatch, data will be gathered and sent. This will require the use of a microcontroller that will be able to read and send information to a computer or application to either be calculated or processed into a format that is suitable for the user to read. As a result, multiple microcontrollers that fit the needs of the Bioelectric Smartwatch were researched and compared.

#### 3.4.1 Comparison of Data Converters

One avenue to consider for the Bioelectric Smartwatch capabilities is to use a low-cost integrated analog front-end for weight-scale and body composition measurement, also known as AFE 4300. This device applies a sinusoidal current into the body between two terminals. As a result, body impedance is measured back with a differential amplifier (Datasheet). Another device similar to the AFE3000 is a complete low power integrated analog front-end for ECG applications, also known as ADS1292. This component has features required in portable, low-power ECG, sports, and fitness applications. The last device is the ADS1115. This component has a programmable gain amplifier and comparator. One thing to note about this component is that it reduces power consumption during idle period. Table 7 shows a comparison of the three data converters and weighs the pros and cons to determine which best suits the Bioelectric Smartwatch's purpose.

**Table 7: Comparison of Data Converters**

Name	AFE 4300	ADS1292	ADS1115
Supplier	Texas Instruments	Texas Instruments	Adafruit
Max. Supply Voltage	3.6 V	5.5V	5.5V
Input Current	30 $\mu$ A	10 $\mu$ A	10 mA
Capabilities	-Weight scale measurements -Supports up to 4 load cell inputs	-Bio potential measurements -Multichannel signal acquisition	-Temperature Measurement Systems -Performs data conversion
Cost	\$4.86	\$11.72	\$14.95

The ADS1115 component was ultimately chosen for the Bioelectric Smartwatch for its multiple features and concentrated focus on temperature prices.

### 3.5 Microcontroller

This section describes the research done to determine the best fit for the Bioelectric Smartwatch's purposes. A microcontroller is a mini computer that is encompassed on an integrated circuit. A microcontroller is often confused with a microprocessor which is very similar; however, it is different from a microprocessor such that a microcontroller is used for embedded applications and many peripherals while a microprocessor is used for has only a CPU inside of it.

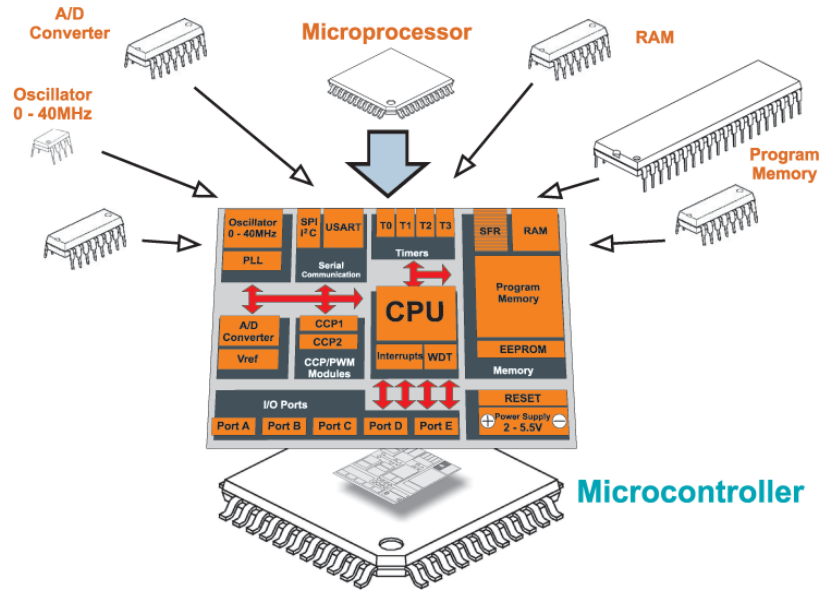
A basic microcontroller is usually comprised of the following elements:

- CPU- Microcontrollers have a central processing unit which is the circuitry that is within a computer that performs instructions delegated by a computer program.
- Fixed amount of memory- Microcontrollers are built with a specified amount of ROM, RAM, or flash memory.
- Inputs and output ports- These include interacting with different interfaces such as LED's LCD's or ports for USB capabilities.
- Serial ports- Typical ports on microcontrollers are serial ports like universal asynchronous receiver/transmitter, also known as a UART.
- Timers- Many microcontrollers have a variety of timers used as oscillators, clock functions, or pulse generation.
- ADC/DAC- Analog to digital converters and digital to analog converters are used

to modify an input signal depending on a device's functionality and application.

- Interpret Control- This type of controller gives delays that are necessary for a program to run optimally.

The image in Figure 10 shows a couple of the components that can be found within a microcontroller and shows the typical layout.



**Figure 10: Image of Basic layout of a Microcontroller**  
 Courtesy of <https://learn.mikroe.com/ebooks>

Multiple microcontrollers were researched; however, three microcontrollers were compared to determine the best fit for the Bioelectric Smartwatch. The comparisons can be seen in the Table 8.

**Table 8: Comparison of Microcontrollers**

Name	Arduino Pro Mini	MSP430FG6626	Raspberry Pi 3
Company	Adafruit	Texas Instruments	Adafruit
DC Input (V)	3.3-12	3.6-5.5V	3.3-5V
I/O pins	14	8	35
Price	\$9.95	\$11.14	\$39.95

The Raspberry Pi 3 was ultimately chosen because of the amount of input and output ports and for easier testing purposes.

### 3.6 Electronic Housing

With all of the components that will go into the Bioelectric Smartwatch, a cover will be in order to house them. Some factors that are needed to be taken into consideration for that type of material used are that it will not irritate the skin, it is durable, it is lightweight, will provide proper insulation. This section goes over the types of materials considered for the smartwatch.

#### 3.6.1 3D Printed Case

3D printing is a process that prints a solid object based on a digital model. It was invented in 1983 and since then, advancements in technology have made 3D printing easily available, cheaper, and faster. Using some computer-aided design, also known as CAD, a design is created. Once the design has been completed, special software is used to split the design into thin cross-sections. Each cross section is printed one layer at a time until the design has been properly completed. Specialized materials are used for the printed material. For the structure of smartwatch, materials like stainless steel, nylon, or acrylonitrile butadiene styrene (ABS). Table 9 gives a comparison of the materials to determine which meets the criteria for the Bioelectric Smartwatch.

**Table 9: Comparison of 3D Printed Material**

Material	Stainless Steel	Nylon	ABS
Strength	Very strong	Strong and flexible	Strong and hard
Thickness	3mm	1mm	1mm
Color	Limited	Can be changed	Can be changed
Cost	Most expensive	Cheap	Cheap

From the Table 9 comparison, the best material is ABS because it is strong and harder than the nylon and seems lighter than stainless steel. Also, ABS may most likely be able to withstand heat caused by loss.

The advantages of 3D printing allow for customization of each watch and specified additions for the features of the Bioelectric Smartwatch. One main drawback to 3D printing is time that will need to be dedicated to learn how to use the CAD software. The Manufacturing Lab in the Harris building on campus offers 3D printing services. The cost of these services is \$5/cubic inch for print jobs.

### 3.7 Display

The display of the Bioelectric Smartwatch will be one of the most important components of the device. The display is the component of the device that the user will interact with the most. The display will also be responsible for exhibiting many of the watch's functions as well as aesthetics. Being that the watch cannot be excessive in size, the display will play a major role in determining the overall size of the device. Since the screen cannot be very large, the display should have a moderately high resolution so that the results presented on the display are easily readable.

There are a few common types of displays that are normally utilized within this type of technology. These displays are the liquid crystal display and organic light emitting diode. Both displays would be suitable for the Bioelectric Smartwatch. There is also a third type of display that could possibly be used. This third display is SHARP's Memory Liquid Crystal Display. This display is a hybrid of both Electronic Ink (E-Ink) technology along with Liquid Crystal Display technology.

However, before a decision can be made on which display is best, there are a few factors that must be taken into consideration that will determine which display would be most suitable for the Bioelectric Smartwatch. All three displays are obtainable, as well as utilized within this type of technology. Therefore, there will be a few significant features or performance attributes that will set one of the displays apart from the other displays.

**Table 10: Basic Display Features Comparison**

Type of Display	Basic Features
Organic Light Emitting Diode Display	Low power dissipation compared to the Liquid Crystal Display, higher quality imaging, and low price
Liquid Crystal Display	Many suppliers, medium power dissipation and lower quality compared other displays, low price
Sharp Memory Liquid Crystal Display	Low power dissipation, higher quality imaging high price

#### 3.7.1 Display Performance

The display of the device is what's going to be most appealing about the watch. Therefore, the display should perform well and be appealing at the same time. Organic Light Emitting Diode displays are composed of thin layers of organic molecules that generate light when electricity is applied to them. Liquid Crystal displays are composed layers of polarizing material that use liquid crystals to operate the pixels in the display.

Comparing the displays, there were some interesting findings. Organic Light Emitting Diode displays are seemingly more preferred than the Liquid Crystal display counterpart. Organic Light Emitting Diode displays are thinner than the Liquid Crystal display. The Organic Light Emitting Diode display poses more pixels per inch (ppi) which offers better black levels and better viewing angles for the user. Thus, producing a higher quality output which is more efficient. The Organic Light Emitting Diode display also consumes less power than the Liquid Crystal display. However, there are some major disadvantages that come along with the Organic Light Emitting Diode display that its counterpart does not experience.

Liquid Crystal displays last longer than that of the Organic Light Emitting Diode. Another disadvantage is that Organic Light Emitting Diode displays are more sensitive to moisture. These disadvantages can be viewed as serious concerns given the unknown conditions in which the device may be used under. Therefore, those two major disadvantages of the Organic Light Emitting Diode display could in turn be the deciding factor in which display we decide to incorporate in the makeup of our device. A visual comparison of the Organic Light Emitting Diode and Liquid Crystal displays are pictured below.



**Figure 11: Visualization Comparison of the OLED Display vs. LCD Display**  
Courtesy of <http://4k.com/oled>

The SHARP Memory Liquid Crystal Display utilizes the low-power consumption of E-Ink and the quick refresh rates of the Liquid Crystal for its output. This display produces higher resolution outputs than its regular Liquid Crystal Display counterpart.

### **3.7.2 Display Cost**

Although performance is very important, cost also plays an important role in the overall aspect of the project as well as which display we will choose to incorporate in our device. The Bioelectric Smartwatch can potentially be used by many people of different demographics. Therefore, we want to utilize the most cost efficient parts to develop our device, while making sure that those parts are efficient and appealing to the user as well. In doing so, the Bioelectric Smartwatch will be desired and obtainable to many individuals.

### 3.7.3 Display Power Requirements

The power requirements differ for both displays. For the displays that we have found so far, the power requirements are dependent on how often the display will be lit. However, there are some figures that represent the on average power requirements for the displays. The OLED display will demand current based on the number of pixels in use. Typically, it will draw about 25mA, but the precise figure is relative to the usage. The Liquid Crystal display will demand current based on the usage of the backlight. When the backlight is at capacity it will demand 50mA. Both displays require a power supply of 3.3V - 5V.

The SHARP Memory Liquid Crystal display will demand current based on the refresh rate of the device. The refresh rate is defined as however often the buffer of the display is updated per second. The refresh rate consists of the measurement of however often a recurrent drawing with an identical number of frames is outputted via the display.

**Table 11: Overall Display Comparison**

Categories	Monochrome OLED	TFT LCD	SHARP Memory
Cost	\$19.95	\$19.95	\$39.95
Display Size	1.30"	1.80"	1.30"
Display Resolution	128x64	128x160	96x96
Weight	2.18 g	2.75 g	2.55 g
Current Draw	40mA	50mA	4 uA
Power Supply Voltage	3.3V or 5V	3.3V or 5V	3.3V or 5V

### 3.8 Battery

Battery life could potentially be a vital concern when it comes to the Bioelectric Smartwatch. The users of the Bioelectric Smartwatch should be able to use the device for at least an entire day without worrying about the device. Due to its lightweight and small that we're trying to achieve with this device, the power of the battery may be limited. Our goal is for the battery to supply all devices that compose the device, to the best of its ability for a reasonable amount of time. Therefore, the battery must be able to power all components of the watch as well as be reliable.

The major factor that could be an issue with the battery for our device is how long it will be able supply power for the device before the battery needs to be recharged. Essentially, that all depends on how the respective user of the device and how they go about using the

device. Therefore, we must conduct the appropriate amount of research to determine which components will work best together and allow for a decent amount of battery lifetime so that the users of the device will be satisfied. To conserve and efficiently use battery power as well as extend the run time of the device, there are a few approaches that we could undertake to achieve those characteristics within our device. There are a few types of batteries that can be utilized within the design of our device. However, the foremost utilized types of batters within most smart watch devices are Lithium Polymer (Li-Po) and Lithium-ion polymer (Li-Ion) batteries. Table 12 provides a comprehensible comparison of both types of batteries.

**Table 12: Battery Advantages and Disadvantages**

<b>Battery</b>	<b>Advantages</b>	<b>Disadvantages</b>
Lithium Polymer (Li-Po)	Slender profile	Lower power capacity
	Light weight	Production is expensive
	Protection circuit	
Lithium-ion polymer (Li-Ion)	Higher power capacity	Protection circuit required
	Low maintenance	Deteriorates over time
	Slower discharge	Thicker profile
	Cheaper to produce	

### **3.8.1 Power Capacity**

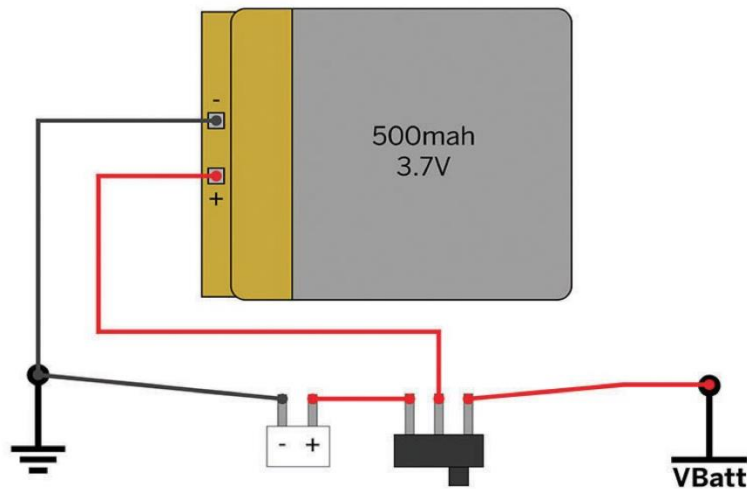
Polymer batteries prove to be the best choice for these types of devices due to their higher power capacity. Power capacity is defined as the amount of energy that is stored within the battery. The power capacity is normally conveyed in Watt-hours (Wh). A Watt-hour is the amount of voltage supplied by the battery, multiplied by the amount of current the battery can provide per hour. In order to obtain the Watt-hours, the Amps per hour is multiplied by the nominal voltage. For example, if there is a 5V nominal battery that has one Amp-hour capacity, that means the battery has 5 Watt-hours of capacity. One Amp-hour indicates that one Ampere of current can be drawn per hour, 0.1 Amps over a time period of ten hours, and 0.01 Amps over a time period of 100 hours. However, before a decision can be made on which battery is most suitable, the two should be compared to



determine which battery would be best for our device.

$$\text{Voltage (V)} \times \text{Current (A)} \times \text{Hours (T)} = \text{Watt - hour (Wh)}$$

**Figure 12: Power Capacity Watt-hour Formula**



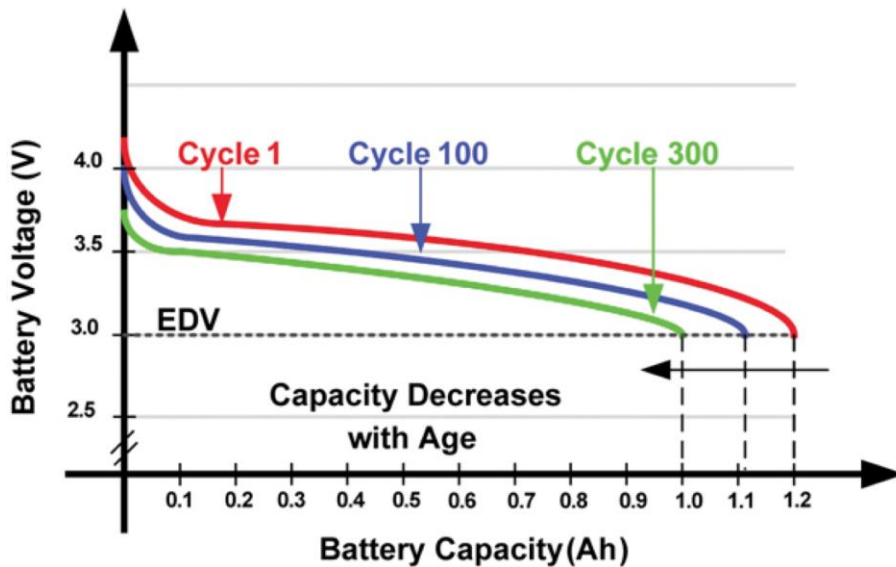
**Figure 13: Battery Connection Schematic Example**  
Courtesy of <https://learn.adafruit.com/all-about-batteries/>

Although, no matter which battery we decide upon to be utilized in the Bioelectric Smartwatch, the battery capacity will naturally decrease over time. This is known as battery self-discharge. This occurs overtime due to the aging of the battery as well as the amount of charge-discharge cycles the battery endures over time. Figure 14 below provides a representation battery capacity throughout multiple charge-discharge cycles.

Upon our we research, we decided that the best battery for our device would be the Li-Ion battery. We believe that the advantages of this battery will work well within our device. There are a few options of Li-Ion batteries available. In choosing which Li-Ion battery will most suitable for our device, one of major deciding factor could possibly end up being the capacity of the battery. A milliampere hour (mAh) describes the capacity of energy charge that a device can operate on before having to recharge the battery. A few options for Li-Ion batteries that would be usable in our device and that will meet our specifications are compared in Table 13.

**Table 13: Battery Logistics Comparison**

Categories	Lithium-ion polymer (Li-Ion) Batteries			
Capacity	350mAh	500mAh	1200mAh	2500mAh
Price	\$6.95	\$7.95	\$9.95	\$14.95
Weight	7.9 g	10.5 g	23.0 g	10.5 g
Size	1.4" x 0.8" x 0.22"	1.15" x 1.4" x 0.19"	1.3" x 2.4" x 0.2"	1.15" x 1.4" x 0.2"
Output	4.2V – 3.7V (1.3 Wh)	4.2V – 3.7V (1.9 Wh)	4.2V – 3.7V (4.5 Wh)	4.2V – 3.7V (10 Wh)



**Figure 14: Battery Capacity Reduction Graph**  
 Courtesy of <https://learn.adafruit.com/all-about-batteries>

### 3.9 Power Management

The microcontroller unit (MCU) and display will more than likely consume the most power in the device. The MCU needs to compute lots of data meanwhile keeping power consumption to a minimum. The display must output data for the user. To conserve power, the display can have minimal outputs and send more data to the web-based application. There are a few available options to be researched when it comes to extending battery life

and effective power management for our device.

### **3.9.1 Energy Harvesting**

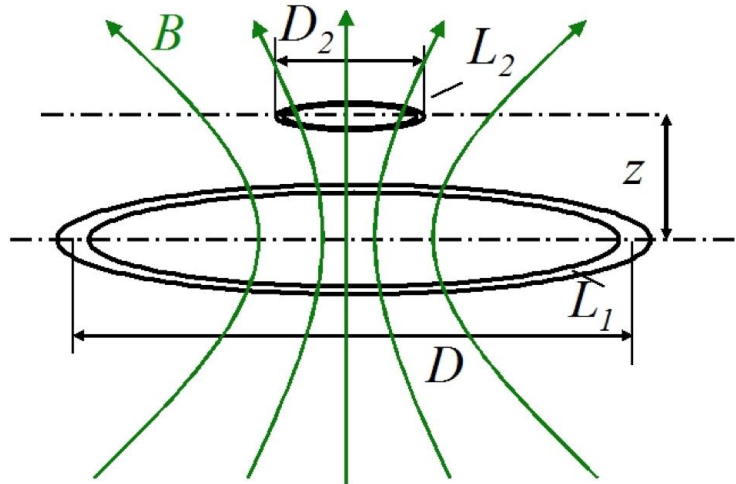
The first method researched when it comes to extending battery life is the energy harvesting method. The energy harvesting method utilizes energy that is collected from the body, due to body heat or movement. Energy harvesting can also utilize energy from the surrounding environment, for example, ambient light. Ambient light is lighting that incorporates the immediate surroundings or environment. The energy collected from the ambient lighting does not provide enough energy to power a device like ours. Usually, this type of energy harvesting option provides a range of microwatts to milliwatts. However, there are devices that can convert as much as 300 - 400 millivolts and amplify the energy collected via this method of energy harvesting to anywhere from 3 – 5 volts, which would be able to power a device such as ours.

### **3.9.2 Conventional Battery Charging**

The next method researched when it comes to extending battery life is the conventional battery charging method. The device can be charged via a battery charger in which an electrical current will be forced into the device supplying energy to the rechargeable battery located inside of the device. The size of the battery will be the determinant of the amount of current over a certain amount of time, the amount of voltage, and protocol for when the battery is completely charged. When a battery is overcharged, it is still connected to the power source even though the battery is already completely charged. When overcharging occurs, the battery may overheat or, at times even explode, which would be detrimental to any device. Some batteries have the propensity to be overcharged, while some can tolerate overcharging. In this method of effective power management, the charging source will be disconnected manually when the charging cycle is completed. There are also some charging devices in which there may be a cut off timer. The charging device can contain voltage and temperature sensors along with a microcontroller that will adjust the voltage and charging current. This charging device can also establish the state of charge (fuel gauge) of the battery and turn itself off at the completion of the charging cycle.

### **3.9.3 Wireless Charging**

The last method of effective power management researched that our device could potentially use is wireless charging, also known as wireless power transfer. This method utilizes a transmitter and receiver to transfer power via electromagnetic fields to charge or recharge a battery. This is accomplished without physically connecting the charging source to the device via any cord. The principle of Inductive Power Transmission is used for wireless power transfer to be accomplished. The theoretical aspect of Inductive Power Transmission is portrayed in the image in Figure 15 and description below.



*The basic principle of an inductively coupled power transfer system is shown above. It consists of a transmitter coil  $L_1$  and a receiver coil  $L_2$ . Both coils form a system of magnetically coupled inductors. An alternating current in the transmitter coil generates a magnetic field which induces a voltage in the receiver coil. This voltage can be used to power a mobile device or charge a battery.*

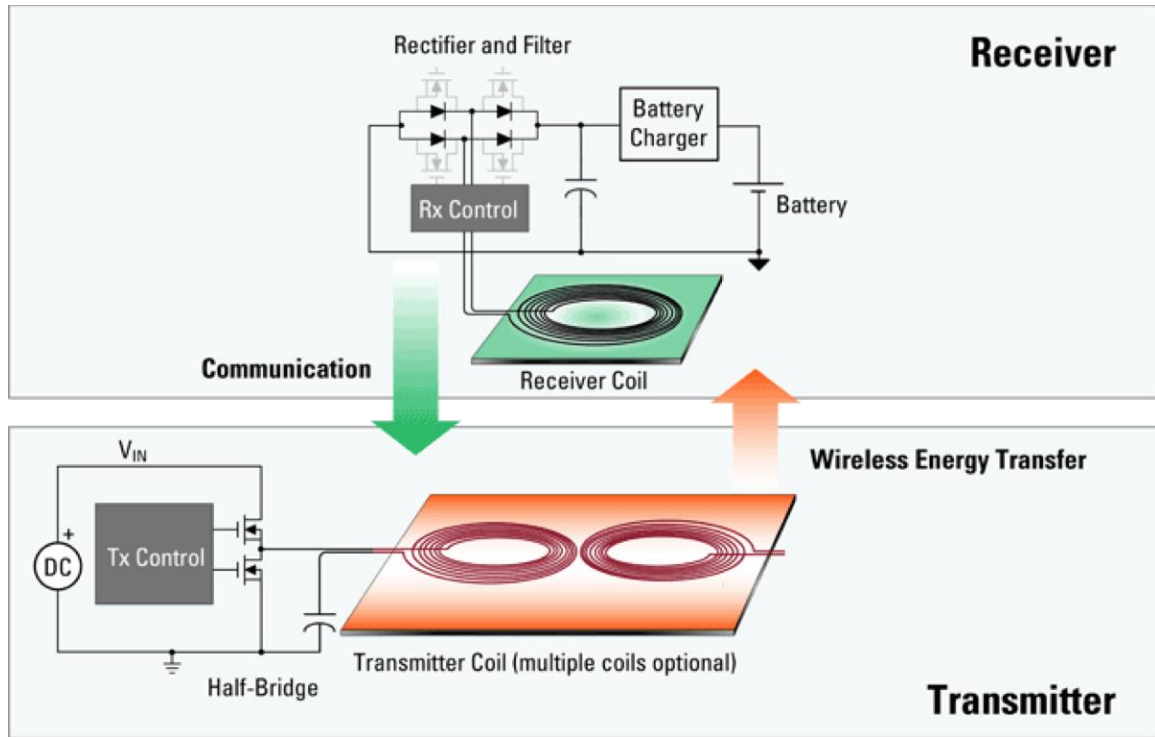
**Figure 15: Inductive Power Transmission Theoretical Display**  
 Courtesy of <https://www.wirelesspowerconsortium.com>

When it comes to how wireless charging works, first, within the transmitter circuit the voltage from the DC source is transformed to a high frequency alternating current. Next, the alternating current is passed on to the transmitter coil, thus generating an electromagnetic field. This electromagnetic field produces a current within the receiver coil in the receiver circuit of the device. The current in the receiver coil is transformed to direct current and that current is used to charge the battery contained within the device. Figure 16 portrays the process by which the battery of the device can be charged during the wireless power transfer process.

### 3.10 Battery Fuel Gauge

Battery fuel gauge which is also known as battery charge indication, which is the exact same as portraying the amount of charge remains in the battery, will be very useful to the users of the Bioelectric Smartwatch. Without proper battery charge indication, the users of the Bioelectric Smartwatch will not be able to determine how much longer they will be able to utilize the device without having to charge the battery of the device. With not being able to determine how much battery power remains in the device, this will hinder the situations in which the Bioelectric Smartwatch may be utilized. For example, if a user of the Bioelectric Smartwatch is going camping and they need to use the device, if they have no way to determine how much power remains in the battery and they become stuck in a situation in which they need to alert someone or signal for assistance and the device dies while they need it, then the Bioelectric Smartwatch would basically be no use to them. The user of the Bioelectric Smartwatch will need to know how much power remains in the

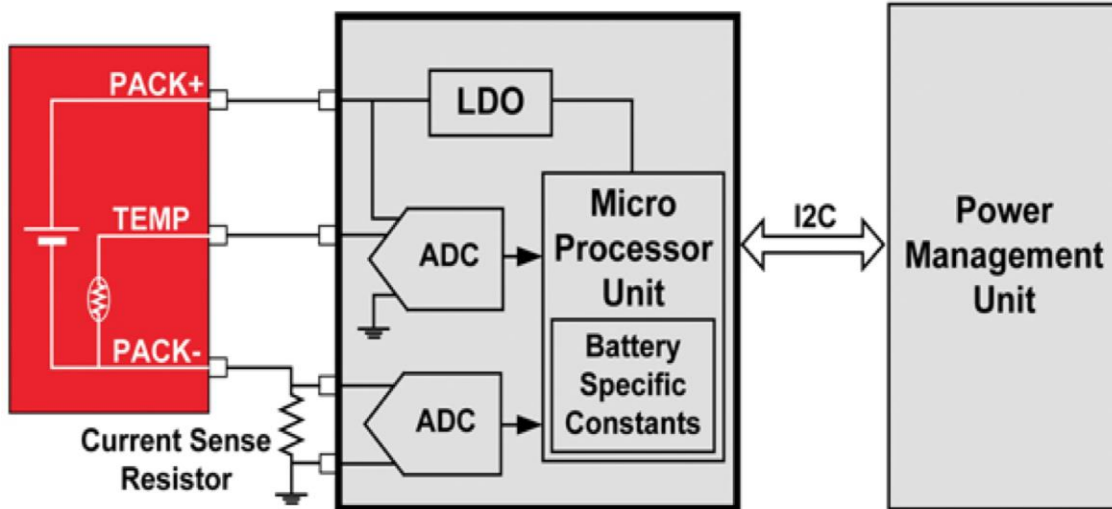
battery so that they may utilize the device and its functions when need be.



**Figure 16: Visualization of Wireless Charging Process**  
Courtesy of <https://www.idt.com/products/power-management/wireless-power>

There are a few ways in which the battery level can be indicated within our device. The battery level can be indicated either via dot or bar form, as well as via Light Emitting Diodes. Within the Bioelectric Smartwatch we can go about indication the battery level in either one of these ways. The battery indication can either be integrated along with other functions of the device, or we can use Light Emitting Diodes to display the percentage of battery power that remains for the Bioelectric Smartwatch to carry out its functions with.

When it comes to the integrated battery fuel gauging, systems normally consist of a couple analog-to-digital converters in which one measures current of the battery, while the other measures the voltage of the battery or battery temperature. The data that is measured by the analog-to-digital converters is transmitted to the microprocessor. The calculations for the fuel gauging is essentially housed within the microprocessor, which contains the necessary data to determine an accurate reading of the battery. Figure 17 portrays the process of integrated battery fuel gauging.



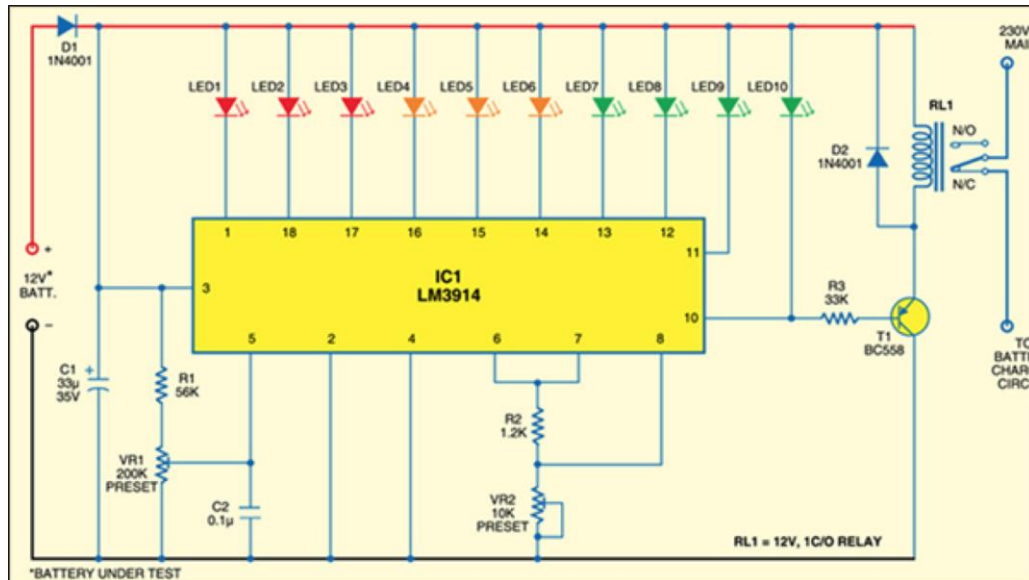
**Figure 17: High-Level Visualization of Battery Fuel Gauge Process**  
 Courtesy of <https://www.ecnmag.com/article/2012/11/fundamentals-battery-fuel-gauging>

When it comes to utilizing Light Emitting Diodes to display the percentage of battery power, this method could either be more complicated due to the amount of hardware, or simpler when compared to the integrated battery fuel gauging, due to software aspect that is utilized in implementing that method. Based on the current-divider rule, this method will utilize a voltage divider network and Light Emitting Diodes of different colors to enable the user of the device to determine exactly what range of battery percentage the device has remaining. Using different colored Light Emitting Diodes enables the user of the device to distinguish exactly how much battery charge percentage remains based on the color coordination of the battery percentage range and a certain color.

**Table 14: Battery Charge Color Indication Levels**

Light Emitting Diode Color	Battery Charge Level
Red	Power to be Connected (0%)
Orange	Power to soon be connected (25%)
Yellow	Power is at halfway mark (50%)
Green	Power is more than halfway (75%)
Blue	Power is a full charge (100%)

An example of a circuit that utilizes Light Emitting Diodes to display the percentage of battery power is displayed in Figure 18.



**Figure 18: Light Emitting Diode Fuel Gauge Circuit Example**  
 Courtesy of [http://rewirring.blogspot.com/2014\\_02\\_01\\_archive.html](http://rewirring.blogspot.com/2014_02_01_archive.html)

To determine which version of fuel gauging we will utilize for the Bioelectric Smartwatch, we will design using both versions, then make a decision via trial and error as well as whichever version cooperates best with the infrastructure of the overall device.

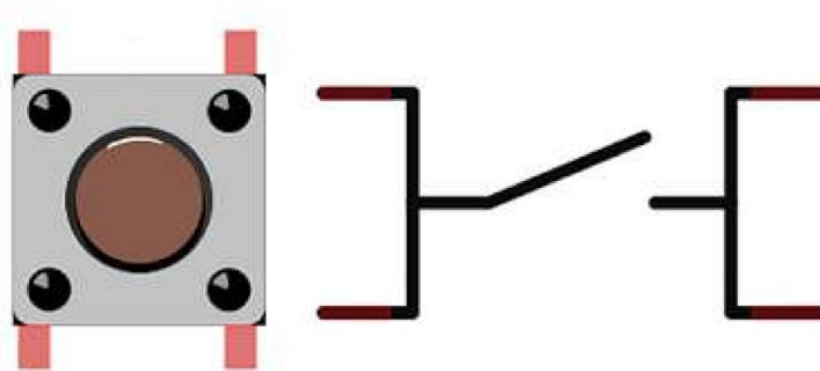
### 3.11 Push Buttons

Believe it or not, but push buttons can play a major role on the overall make-up of the Bioelectric Smartwatch. The amount or the size of push buttons can affect as many things such as: how large the size of the watch will be, how many settings or functions can be assigned to each push button, as well as how appealing the watch might be.

A push button is essentially a switching type instrument that controls some type of feature or characteristic of a process or mechanism. Push button are usually composed of some type of firm material such as metal or plastic. Push buttons typically possess a flat shape and are suited to adapt to the human hand or finger so that the button can be easily operated. Push buttons are usually biased switches. A biased switch is a switch that is normally in its set position, and returns to that position once engaged. Biased switches include an instrument that returns the button to its original position once the button is pushed then released by the operator. Usually, push buttons are normally open mechanisms. When the push button is pressed, contact is made. When the push button is released, contact is broken.

For the Bioelectric Smartwatch, we decided on a four-button configuration. The operations in which the four push buttons will be used for are one button for selection, one button to cancel, and two buttons for movement up or down on the display. There are a couple types of push buttons that we can use for the Bioelectric Smartwatch. The first option is an illuminated push button. These types of push buttons include a light within the button which saves electricity and space within the hardware of devices. Next is the long-life push button which typically last for an extended period of time. Lastly, there's the low-profile push button which are not as large as typical push buttons and allow designers to

save space within their applications.



**Figure 19: Push Button Operation Illustration**  
 Courtesy of <http://nilza.net/mainpage/detail/push-button-switch-schematic>

**Table 15: Push Button Quick Facts**

	Illuminated	Long Life	Low Profile
Contact Rating	0.1A	50mA	20mA
Expectancy	50,000 Cycles	100,000 Cycles	100,000 Cycles

### 3.12 Pulse Sensor

Pulse sensors can be useful in a watch, because heart rate can be connected to many different things. Today, fitness watches are able to measure pulse in 2 different ways. The first, and most conventional method of taking heart rate is by using an electrocardiogram (EKG). The second method is Pulse Oximetry.

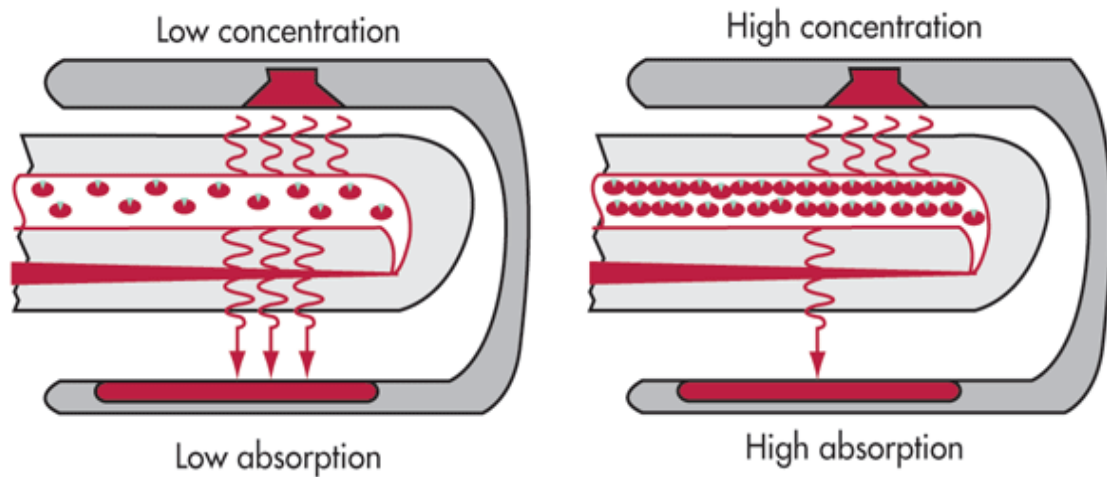
#### 3.12.1 Electrocardiogram

The first method discussed the EKG. The EKG is either attached around the chest with a sensor near the heart, or a clamp goes on the fingertip. An EKG is made up of an electrode that attaches to the body to measure the current flow, an amplification and filtering stage, and a data processing stage. The electrode sends the voltage signal from the body to the amplification stage. From the amplification stage, the signal then passes through multiple filters to filter out certain bodily and power system frequencies that are unnecessary noise. The output waveform will be a voltage representation of the pulse; thus you will see the



peaks and troughs of the heartbeat.

### 3.12.2 Pulse Oximetry



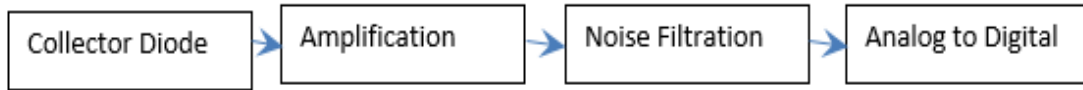
**Figure 20: Pulse Oximetry Illustration**  
Courtesy of <http://electronicdesign.com>

The second method of reading pulse is by using photo plethysmography (PPG). PPG is the technique used by more advanced watches today like the Fitbit, and the iWatch. The act of using PPG to analyze the amount of oxygen in the blood is called Pulse Oximetry. Pulse Oximetry uses the light reflecting and absorbing properties of hemoglobin to analyze heart rate, amount of oxygen in the blood, and blood flow rate. The Lambert-Beer law defines how much light is absorbed by the hemoglobin in the blood with light of different wavelengths and distance traveled. LEDs are used to illuminate the blood, and light sensitive diodes absorb the light to measure how much light is reflected, or absorbed through the blood. Typical frequencies of light used are red (650nm), and infrared (940nm). Sensors on the finger measure the amount of light absorbed by the hemoglobin, because the LED shines on one side of the finger, and the light collecting diode is on the other side. 2 different wavelength LEDs are used in conjunction to observe the difference in reflection of each. In a watch application, the amount of light reflected by the hemoglobin is used, because it would be difficult to measure the absorption of blood through a thick body part like a wrist, and the watch band would need to have a component in the clasp. If the collector was in the clasp, then it would be difficult to have a one size fits all type of design, and have the collector line up with the emitter.

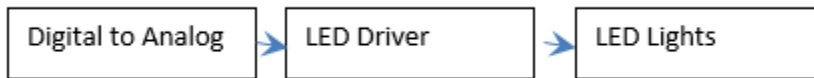
Product list of a working heart rate monitor utilizing PPG:

- PPG sensors (LED emitter, diode collector)
- Analog front end (amplification, filtering)
- Low-powered microcontroller
- Wireless module for exchanging data
- Motion sensor (accelerometer) monitoring user's motion
- RAM for data logging
- Lithium battery

- Battery charger
- Battery fuel gauge

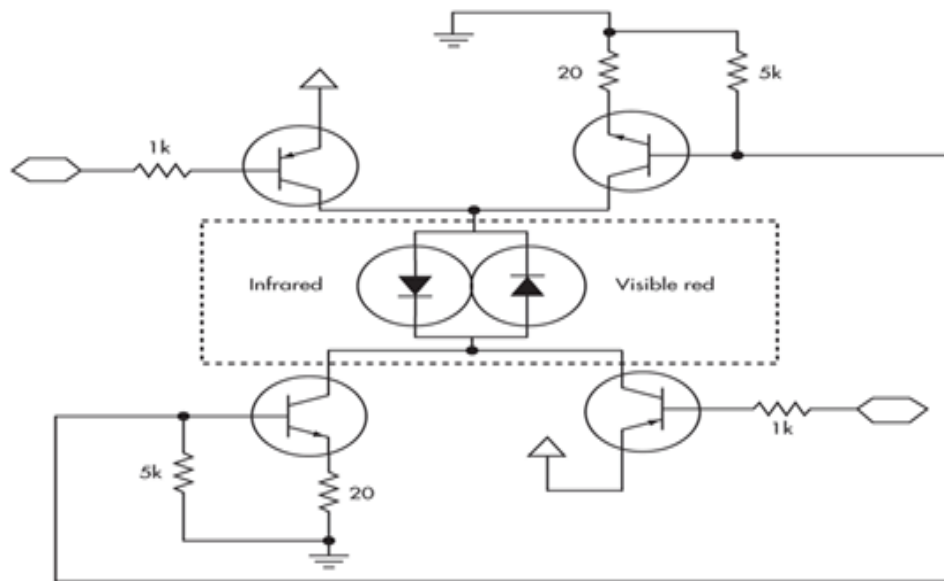


**Figure 21: High-Level PPG Sensor Diagram**

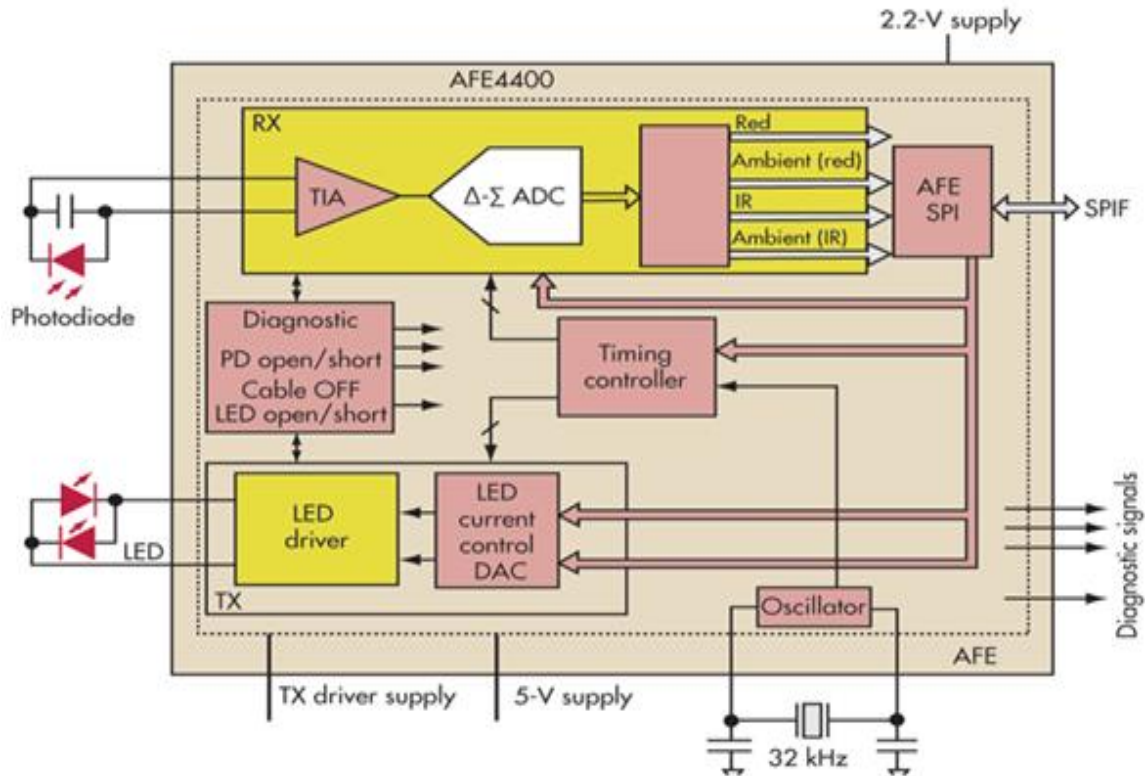


**Figure 22: High-level LED Controller Diagram**

The driving LED circuit is an H-bridge driver. The circuit controls the on and off times of the IR and red LEDs by using pulse-width modulation (PWM). The analog signal is amplified by BJTs to drive the LEDs. Typical designs use 25% duty cycle for each LED. The quality of the photodiode can change the life of the battery, because you can scale the PWM down if the photodiode is of good quality.



**Figure 23: H Bridge Driver Design for LEDs**  
 Courtesy of <http://electronicdesign.com>



**Figure 24: AFE4400 Design**  
 Courtesy of <http://www.ti.com/product/AFE4490>

Companies put together the analog front end (AFE – amplification, and filtering of input) and the LED driver circuitry in one package. This can make it convenient for this project, instead of having to design separate circuits, we could purchase this product. Or, products like this can be observed to create a similar product to fit the needs of this project. An example of such product is Texas Instruments’ *AFE4400 Integrated Analog Front End for Heart Rate Monitors and Low Cost Pulse Oximeters*.

The AFE4400 is a fully-integrated AFE that is tailored towards pulse oximetry. The device contains a low noise receiver (to filter possible noise from measurements, outside 60Hz interference, and bodily interference), and analog to digital converter, LED control circuit, and LED fault detection.

The timing of the AFE is configurable, meaning that the PWM is able to be controlled to change sampling frequency. An external crystal oscillator provides the clock function of the AFE, thus reducing jitter – deviation from keeping true time. This AFE device is designed to communicate to an external microcontroller via Serial Peripheral Interface bus (SPI). The AFE4490 model offers the same solutions in one single package, but contains a few upgraded features. The feature comparison is shown below.

**Table 16: Comparing AFE4400 and AFE4490 Pulse Oximetry Analog Front Ends**

	AFE4400	AFE4490
Fully Integrated AFE	Yes	Yes
Dynamic Range (allows low noise at low LED currents)	95dB	110dB
LED current	50mA	50mA, 75mA, 100mA, 150mA, 200mA
Power Consumption	100 $\mu$ A+LED current	100 $\mu$ A+LED current
LED timer programmability	Yes	Seems like more features?
Filter Flexibility	Less	More
Temperature Range	0C-70C	-40C-80C
Cost	\$6.32 ea.	\$17.27 ea.

As one can see, the AFE4490 is a more robust AFE design than the AFE4400, but costs almost 3 times as much. The AFE4400 may be enough for this project, but further research must be conducted. It may be beneficial to order both products to test each, and see which is the better fit for the smartwatch project. The AFE4490 does have many more features that reduce noise, make it more useful in a variety of colder climates, and to drive more powerful LEDs. Whether this is necessary is what must be considered.

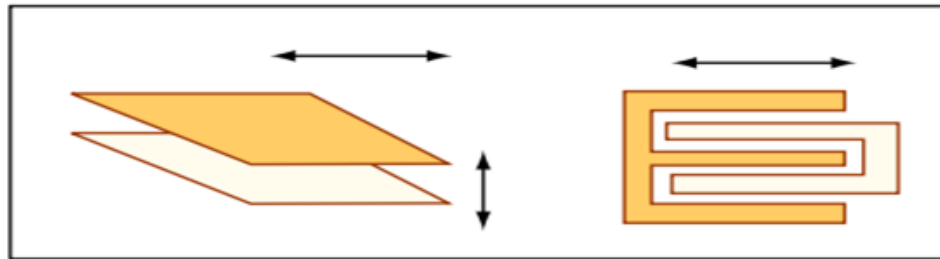
### 3.13 Accelerometer

An accelerometer is a device that measures dynamic and static acceleration. Dynamic accelerations are essentially vibrations, and quick movements, and static accelerations are steady accelerations like gravity. Accelerometers can measure as little only 1 axis, or as many as all 3 axes. 3 axis accelerometers are more common now, and are reasonably cheap.

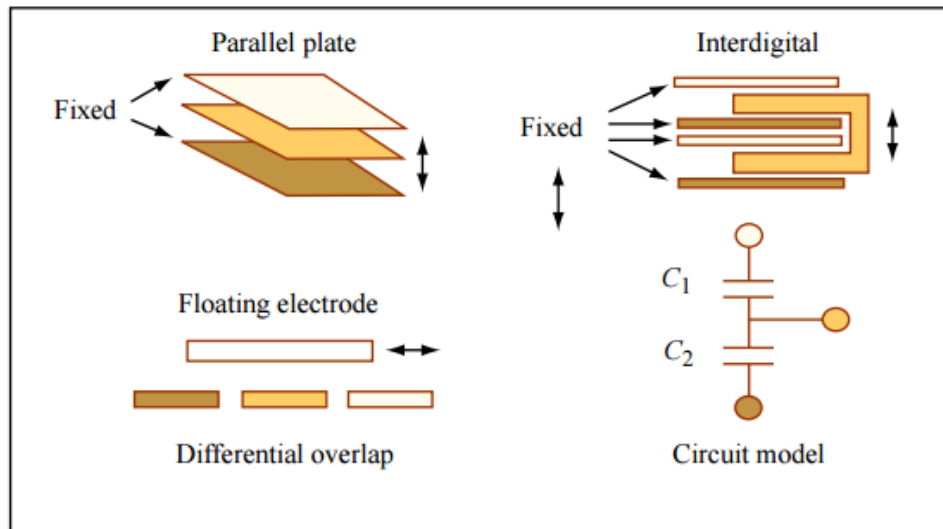
### 3.13.1 Capacitive Accelerometers

Capacitive accelerometers work off changing capacitance. The 2 main types of capacitive accelerometers are single capacitor accelerometers, and differential capacitor accelerometers. Single capacitor accelerometers measure the change in capacitance that occurs when two capacitive plates move closer or farther away from each other. Differential capacitor accelerometers measure the change in capacitance on multiple plates while the plates shift due to movement. Differential capacitor accelerometers give a more linear output signal, because it measures the difference between different capacitor values. Some advantages of capacitive accelerometers are: DC measurements, good stability in different temperatures, long life, and good repeatability. Some disadvantages are: complex design, and sensitivity to electromagnetic fields.

A basic voltage divider can describe the output voltage of the accelerometer circuit. Thus, when movement causes the change in capacitance, the output voltage will also change. The voltage divider equation for the above circuit is given by.



**Figure 25: Single Capacitive Accelerometer Diagram**  
Courtesy of <https://ocw.mit.edu>

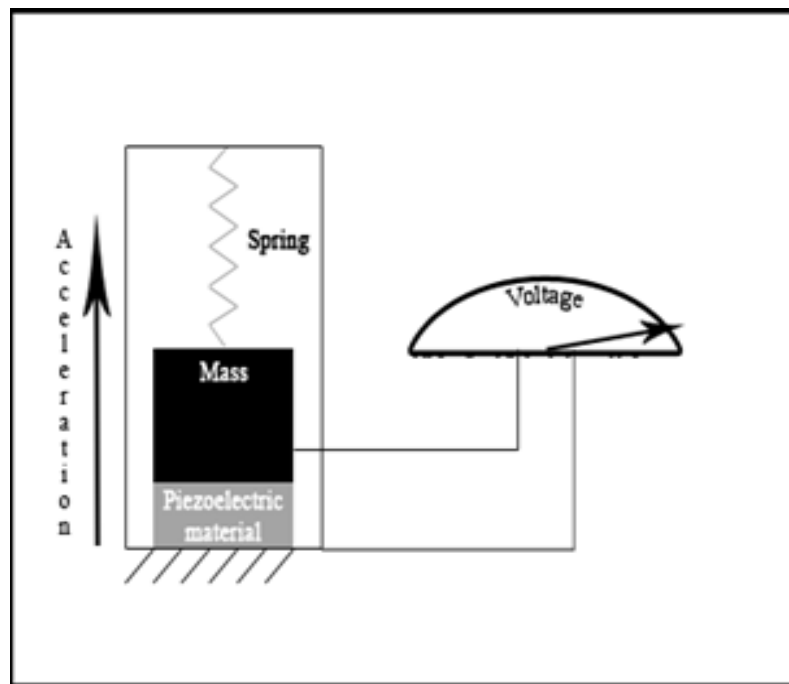


**Figure 26: Differential Capacitive Accelerometer Diagram**  
Courtesy of <https://ocw.mit.edu>

### 3.13.2 Piezoelectric Accelerometers

A piezoelectric material is a material that creates an electric signal when a force is exerted upon it. This is very useful for an accelerometer, because it makes it possible to change motion forces directly into a measurable electric signal. Typically, a spring with a mass on the end is attached the piezoelectric material. The movement causes the mass to move slightly, which then compresses and contracts the piezoelectric material.

Piezoelectric accelerometers can be separated into 2 separate categories: single crystal, and ceramic materials. Single crystal accelerometers consist of 1 crystal, typically quartz, are the most common and have a very long service life. The drawback of single crystal accelerometers is that they are not very sensitive. The second type of accelerometers, ceramic material accelerometers, are more sensitive and less expensive to produce. They some piezoelectric materials in the ceramic accelerometers are barium titanate, lead-zirconate-lead-titanate, lead metaniobate. The main drawback of ceramic material accelerometers is that their sensitivity degrades over time. Thus, single crystal accelerometers should be used for projects that are designed to require less maintenance, and a higher service life.



**Figure 27: Diagram of Piezoelectric Technology**  
Courtesy of <https://en.wikipedia.org>

### 3.13.3 Accelerometer Comparison

All 3 accelerometers in Table 17 are MEMS capacitive accelerometers. Capacitive are the most common accelerometers. Table 17 highlights the main parameters that need to be observed when considering an accelerometer. The size of each accelerometer is very small, but the smallest of the 3 is the LIS3DH.

The accelerometer needs to be as small as possible to fit in a watch application. The input voltage of each accelerometer is approximately the same, and is a standard voltage range that works with most microcontrollers. Accelerometers are sensitive to overvoltage; thus, the input voltage needs to be considered a priority. The current consumption of the LIS3DH is also very low in comparison to the other 2 accelerometer choices, which is favorable because the watch battery will not be very large. The accelerometer will also be running often, so low power consumption is a key factor.

**Table 17: Comparison of 3 Different Accelerometers**

	ADXL345	ADXL335	LIS3DH
Size	3x5x1mm	4x4x1.45mm	3x3x1mm
Input Voltage	2-3.6V	1.8-3.6V	1.7-3.6V
Max Current Consumption	145 $\mu$ A	350 $\mu$ A	100 $\mu$ A
Min Current Consumption	40 $\mu$ A	320 $\mu$ A	2 $\mu$ A
Measurement Range	+/- 2g - +/- 16g	+/- 3g	+/- 2g - +/- 16g
Sensitivity	232 - 286 LSB/g	270-330 mv/g	1mg/digit - 12mg/digit
Data Rates	6.25-3200 Hz	0.5-550 Hz	1Hz-5 kHz
Temperature Sensor	No	No	Yes
Price	\$18	\$15	\$5

Both the LIS3DH and ADXL345 accelerometers have more programmable measurement ranges, however this will not be quite as crucial as the other factors. The LIS3DH also has a very sensitive sensor. This is of interest, because the forces exerted by the user are very insignificant when compared to 16g's. the LIS3DH also contains a temperature sensor, and is the cheapest option. The LIS3DH is the ideal accelerometer for this project, but the ADXL345 will also be purchased, because it may work better in practice.

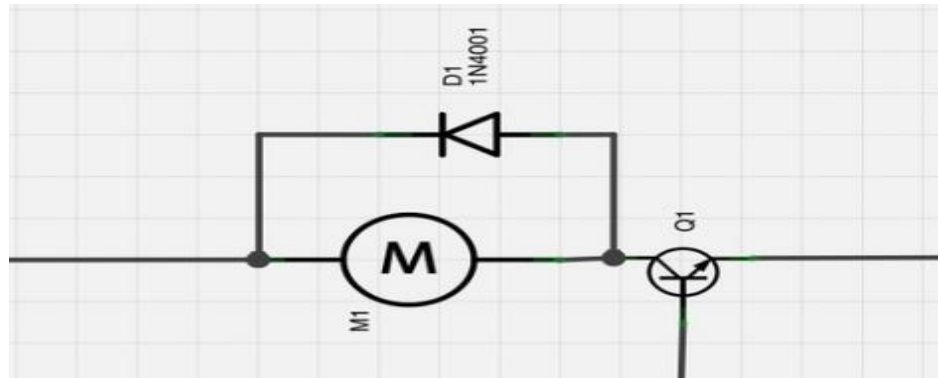
### 3.14 Vibrating Motor

The smartwatch will need to provide silent notifications to the user, thus a vibrating motor will need to be used. A small vibrating motor will be installed in the watch to alert the user of something happening. When choosing a motor for this project, a few specs need to be considered. The first, and perhaps the most important spec for this project is the size. Motors are generally large devices; thus, compact configurations are needed. Disk motors work well, because they are flat, and can fit in tight spaces. The next spec to consider is the voltage and current draw of the motor. This smartwatch is limited by lower voltages

and current capabilities, so the motor cannot require a large supply voltage and current. The motor also cannot be overwhelmingly loud and powerful.

### 3.14.1 Motor Control Circuit

Most microcontrollers cannot output enough current to supply a motor safely. A transistor may be used to control throttle the motor with minimal output required from the microcontroller's output pin. The transistor will act as a throttled switch, with the output of the Arduino connected to the base of the Bipolar Junction Transistor (BJT). As the current from the microcontroller is increased, the flow of current from the emitter to collector of the BJT increases. The microcontroller will be able to change the PWM of the output to adjust the current flow to the base of the BJT. The collector of the BJT will be hooked up to the voltage supply. A diode will be placed in the opposite direction of the flow of current to prevent from an inductive current spike caused by the motor. A common BJT to use for this circuit is a PN2222, and a common diode used for this is an IN4001.



**Figure 28: Motor Control Circuit**  
Courtesy of <https://learn.adafruit.com>

The motor chosen for this smartwatch will be the vibrating motor mini disk that is sold from Adafruit.com. The motor can work with voltages from 2V-5V, and currents from 40mA-100mA. The 40mA current draw is ideal for the smartwatch application, thus the low voltage 2V threshold will be where the watch will be set to. The user will not need a large vibration to be alerted, but the option is available if a more powerful jolt is necessary.

### 3.15 Printed Circuit Board

All the components that will be incorporated in the Bioelectric Smartwatch will be placed on a printed circuit board (PCB), a necessary component in the fabrication and testing of electronic circuits. A PCB is a thin sheet that has conductive etched or printed tracks on, usually made of copper, on its surface which is also known as the substrate. To connect electrical components to each other. Holes are placed throughout the circuit so that components that are “through hole” can be placed and soldered. A PCB can have one side, double-sided, or have multiple layers, depending on its functionality. Double-sided PCBs are used when one side becomes too cluttered by the number of components that are placed, which can cause sparks. This can pose potential health risks especially in wearable applications like the Bioelectric Smartwatch. Multiple-layered PCBs have the different



layers compressed into one sheet, allowing for a greater number of components to be placed and interconnections to occur.

PCB's can be designed using computer software like Easily Applicable Graphical Layout Editor (EAGLE). This software is a free automation design tool to layout the placement of components. As a result, many parameters can be specified to fit any design. Due to its popularity, many tutorials and guides are available for reference and ease of use.

### **3.16 Watch Band**

The watch is a seemingly unimportant piece of the smartwatch project, but the user must have a comfortable, well-fitting wrist band to secure the watch to their wrist. An excellent watch cannot have a low-quality watch band. A few things need to be considered when choosing a watch band. First is the material. The material of the watch needs to be comfortable, but durable. A few common materials for watch bands are silicone, steel, titanium, and nylon.

Steel and titanium are premium materials that offer long life, but are very expensive. Silicone and nylon are more popular for smartwatches, and are the cheaper options. They also offer many color combinations to give the customer more of a selection to choose from. The next thing to consider is how the watch band attaches to the watch. The watch band will have to be wide enough to stabilize the watch face, while still being able to line up with the pins on the watches edges. Silicone watch bands offer many sizes and connection configurations. Silicone will be the material used for this project, because it is durable, cheap, comfortable, and adaptable to many different situations. Other smartwatches like the Apple Watch, Fitbit, and Garmin Forerunner have all had success with silicone wrist bands.

### **3.17 Bluetooth**

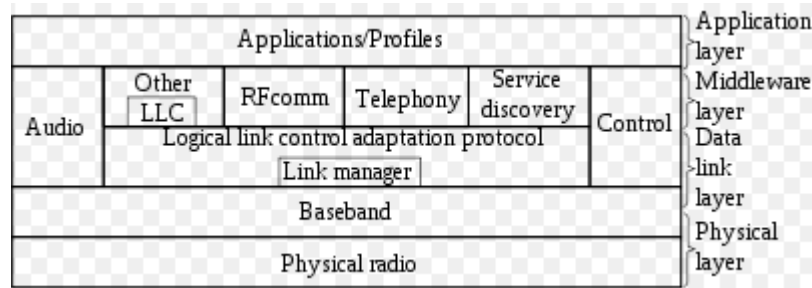
Bluetooth is a wireless standard for sending and receiving data over short wavelengths and distances from fixed network and mobile devices. It was invented to by telecom vendor Ericsson as an alternative to data cables. It can connect to up to seven devices at a time, thus solving problems with technology that older devices faced. Bluetooth is managed by the Bluetooth Special Interest Group (SIG), all manufacture of Bluetooth device must meet the Bluetooth SIG standards.

Bluetooth operates at the frequencies between 2402 and 2480 MHz, or 2400 and 2483.5 MHz including guard bands 2MHz wide at the bottom end 3.5 MHz wide at the top. Bluetooth use radio technology called the frequency hopping spread spectrum, the data divides transmitted data into packets, and transmits each packet on one of 79 designated channels. The frequency-hopping spread spectrum is a method of transmitting radio signals by rapidly switching a carrier among many of the ranged frequencies channels, using a pseudorandom sequence known to both transmitter and receiver. It used as a multiple access method in the code division multiple access. Bluetooth use low energy and performs about 800 hops per second, when the Adaptive Frequency Hopping is enabled.

### 3.17.1 Bluetooth Protocols

Bluetooth has a master-slave structure for the packet-based protocol. Meaning that one master may communicate with up to seven slaves in a piconet. A piconet is an ad hoc network that links a wireless user group of devices. It consists of two or more devices occupying the same physical channel. All the devices share the master clock with the master. Packets exchange is based on the basic clock, defined by the master, which ticks at 312.5 picoseconds intervals. The simplest case of the clocks of a single-slot packets the master transmit in even slots and receive in odd slots. The slave receives in even slots and transmits in odd slots. The packets may be 1,3, or 5 slots long. However, the master transmission starts in even slots and slave in odd slots.

The Bluetooth protocol stack is defined as a layered protocol architecture that consists of cable replacement protocols, telephone control protocols, and adapted protocols. The Core protocols for the all the Bluetooth stacks are: LMP, L2CAP and SDP. LMP is the Link Management Protocol is used to set-up and control of the radio link between two devices. L2CAP – the Logical Link Control and Adaptation Protocol is used to multiplex multiple local connections between two devices using higher level protocols. The SDP- Service Discovery Protocol allows a device to discover services by other devices, and their associated parameters.



**Figure 29: Bluetooth Protocol Stack**  
 Courtesy of <https://en.wikipedia.org/wiki/Bluetooth>

### 3.17.2 Bluetooth Range

Bluetooth range varies due to the conditions, material coverage, antenna configurations and battery conditions. The typical conditions for Bluetooth are for indoor condition, where the attenuation of walls and reflections are minimal and lower due the specified line of sight range for the devices. To use the Bluetooth a device must be able to interpret the certain Bluetooth profiles, which are definition of possible application and specify general that Bluetooth-enabled device to communicate with.

**Table 18: Bluetooth Versioning Comparisons**

Bluetooth Version	Maximum Speed	Maximum Range
3.0	25 Mbit/s	n/a
4.0	25 Mbit/s	200 feet (60 m)
5	50 Mbit/s	800 feet (240 m)

### **3.17.3 Bluetooth Pairing**

Implantation of Bluetooth of the pairing the two devices establish a relationship by creating a shared secret know a link key. When both devices store the same link key, they are considered bonded or paired. Then when a divide want to communicate only with a bonded device can authenticate the identity if the other device. Link key is generated, an authenticated and Asynchronous Connection-Less between devices may be encrypted to protect changed data against eavesdropping.

The Asynchronous Connection-Less is important to avoid latency to help when the payload. In this type of link, if a payload encapsulated in the frame is corrupted, it is retransmitted. A secondary returns an ACL frame in the available odd-numbered slot if and only if the previous slot has been addressed to it. ACL can use one, three or more slots and can achieve a maximum data rate of 721 Kbit/s. The user can delete link keys from either device, which remove the bond between the device. It is possible for one device to store a linked key for a device it no longer paired with.

There a few paring mechanisms the current one that being use right now for Legacy pairing, which is method that available with Bluetooth 2.0 and before. Each device must enter a PIN code. The pairing would be considered successful if both device enter the same PIN. The other mechanism Secure Simple Pairing (SSP) device may only legacy paring to uses a form of public key cryptography, and some types can help protect against man in the middle attacks. The SSP is used commonly now because is considered simple for many reasons.

- It doesn't require a use to generate a passkey.
- Using OOB and NFC enables pairing when devices simply get close, rather than requiring a lengthy discovery process.
- MITM protection can be achieved with a simple equality comparison by the user.
- Uses-cases not requiring MITM protection, user interaction can be eliminated.

### **3.17.4 Bluetooth Security**

Bluetooth implements confidentiality, authentication and key derivation with custom algorithms based on the Secure And Fast Encryption Routine SAFER+ block cipher. This cipher use the same round function consisting of four stages: a key-mixing stage, a substitution layer, another key-mixing stage, and finally a diffusion layer. Bluetooth key generation is generally based on a Bluetooth PIN, which must be entered both devices. Though being exposed in 2008 this technology is commonly used for small powered devices.

### **3.18 Global Positions System (GPS)**

This section gives an overview on the research and background information that will be implemented when designing and creating the global positioning system features for the Bioelectric Smartwatch. Included in this section are as follows:

- a brief background of about global positioning systems
- application of global positioning systems
- a comparison of a couple global positioning modules

Analysis and research was done in order to best meet the needs for the Bioelectric Smartwatch.

#### **3.18.1 GPS Background**

The Global Positioning System is space- based radio navigation system owned by the United States government and operated by the Unites States Air Force. GPS provides geo location a and time location to a GPS receiver anywhere on or near the Earth where there is an unobstructed line of sight to four or more GPS satellites. The GPS system typically operates independently of any telephonic or internet reception, through these technologies can enhance the usefulness of the GPS positions information. The GPS can be sued commercial, civil, and military uses. The US government can selectively deny access to the system as the seek fit for the protection for the country.

Since being launched during the Cold War to overcome the limitations of previous navigation systems. Transit was the first satellite systems launched by the USA and tested by the US Navy in 1960. Then the soon thereafter launched five satellites orbiting the earth allowed ships to fix their positions on the seas every hour. That made the Transit successful because of the highly accurate atomic clocks could be operated in space. Navstar completed the modern GPS constellation of satellites that network 24. The GPS 21 of the constellation are active and they have 3 spares.

### 3.18.2 Application of GPS

The most common application after the initial military uses were for commercial civilian application. Millions of users rely on the GPS system navigation in vehicles, aircraft, and ships. This allows with a receiver to pinpoint their speed and positions on land, air and sea, with incredible accuracy GPS also available for uses like hikers and rambler can use GPS receivers to ensure they following their chosen route to the points along the way. Another, example services for instance, can use GPS not only to find their way to an incident quicker than ever before and pinpoint the location of accidents and to allow the correct assistance to arrive faster. This can and be sued for rescue teams that are looking for rescue during extreme conditions. Research in the STEM fields have also use applications to make sure for monitoring geographical activity. The GPS can help with predicting climate change and produce accurate map.



**Figure 30: General Satellite with Antenna**  
Courtesy of <http://www.mio.com>

### 3.18.3 GPS Alignment and Structure

There are three part to the GPS a constellation of 24 to 32 powered satellites orbiting earth. The satellites are orbiting at the altitude about 20000 kilometers. They have master control station and four control and monitor stations across the globe. Each of the orbits of the satellites the receivers to detect at least for of the other four operational satellites. The satellites send out microwave signals to a receiver where the built-in computer uses the signals to work the accurate distance from each of the four satellite and then triangulate you positions on the planet nearest based on these directions. The fourth signal is redundant and is used to confirm the results of the initial calculation. If the position calculation from 1-2-3 does not match the calculation for 1-2-4 then the combinations of other satellites are

tested till they are consistence. There is a process to measuring the distance is based on time interval signals. There are time lags when a receiver picks up signal from a different satellite.

### **3.18.4 GPS Mapping Software**

The main use for use for the GPS is the navigation so the GPS mapping software has been up to date. Generally, the road and structure are changes by 5 percent every year. Thus, when new infrastructure is built, that changes the speed limits, and traffic signals for examples. The mapping structure need to be often updated.



**Figure 31: Sample of GPS Satellites Orbiting Earth**  
Courtesy of <http://www.mio.com>

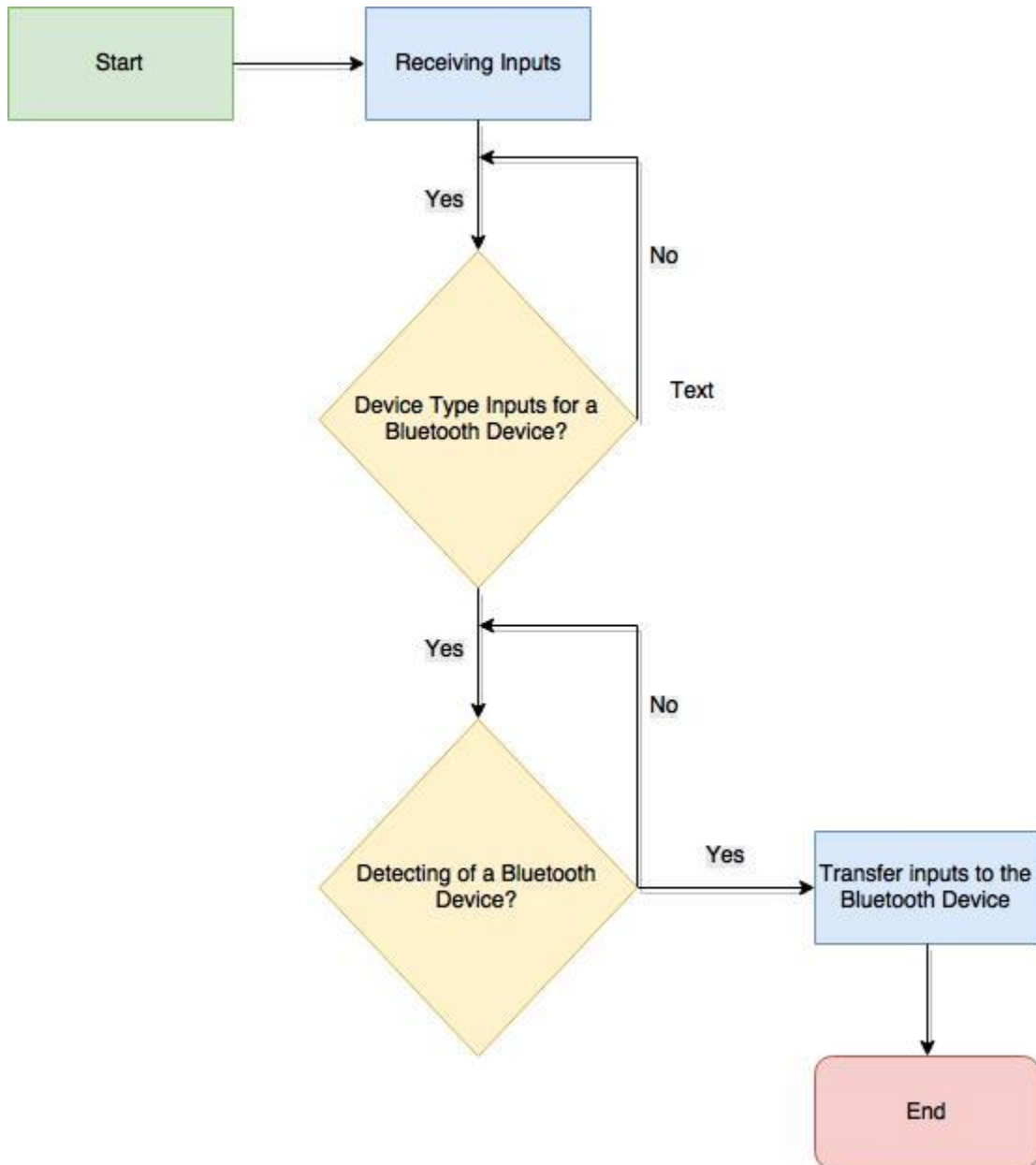
The advantages to digital mapping include not rely on traditional method road map atlas that can be obsolete in some areas. Companies in digital mapping work constantly to update the GPS software to make it more available to their customers and most have the most reliable navigation device. Most of the GPS satellites do not provide the maps software, they instead offer the position lock that is then overlaid on the maps by your GPS receiver.

All navigation devices come with preloaded maps, but to make sure you have the latest maps for your navigation device, you must install updated GPS mapping software regularly on your devices. Map updates are available in two forms: either purchase an expansion card from a retailer or go online and download the updates to your computer ready for installing next time you connect your navigation device.

The components inside a navigation device has a specific purpose and each is essential to the functioning of the device. There are circuits too that control the information, map and route displayed as well as to produce spoken directions and camera alerts in some models.

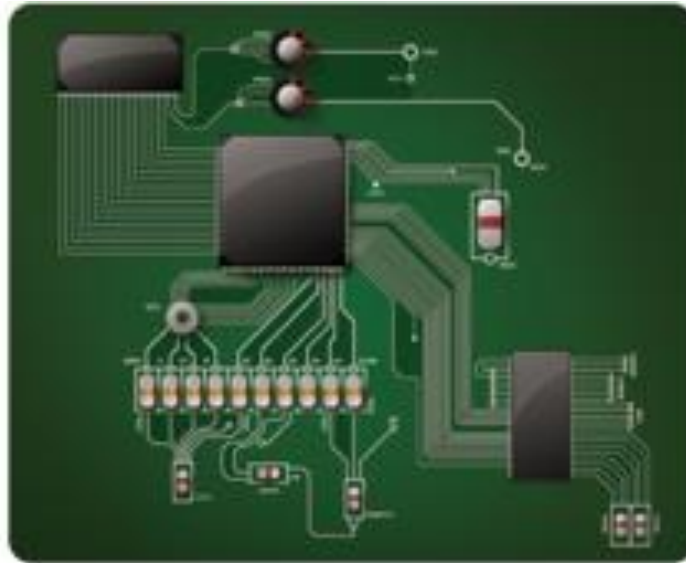
In order to carry out its main job of locking on to the global positioning system (GPS). The GPS receives the microwave signals from the satellites in the GPS constellation. The signals are then amplified and fed to the integrated circuits that analyze the signals and calculate your position.

The circuitry uses a system known as trilateration, which is the 3D equivalent of trilateration on a map. The trilateration process depends on the GPS device being able to determine the distance to the satellites by timing the signals using its inbuilt clock. The clock itself is an electronic circuit known as an oscillator.



**Figure 32: Diagram Roadmap of Bluetooth Connection**

### 3.18.5 GPS An Inside Look



**Figure 33: General Internal Components of GPS**  
Courtesy of <http://www.mio.com>

### 3.18.6 GPS Trilateration

The trilateration is to determine the positions of the surface by the earth's timing signals from three satellites in the GPS. The network that orbit the earth and send a signal to the GPS receivers providing precise details of the receiver location, the time of the day, and the speed of the device is moving in the relation to the three satellites. The signals travel at the speed of light, but there is a delay because the satellites are at an altitude of tens of thousands of kilometers above the earth.

Once a GPS device has distances for at least three satellites, it can perform the trilateration calculations. Trilateration works in a similar way to pinpointing your position on a map knowing the precise distance from three different landmarks using a pair of compasses. Where the three circles centered on each of the landmarks overlap is your location given the radius of each circle is your distance from each landmark.

Calculations are processed happens fast that allows the GPS device to pinpoint its location, altitude (if it is in an aircraft), speed and direction. The transmissions are timed to begin precisely on the minute and the half minute as indicated by the satellite's atomic clock. The first part of the GPS signal tells the receiver the relationship between the satellite's clock and GPS time. The next portion of data gives the receiver of the satellite's precise orbit information.





**Figure 34: GPS Trilateration Configuration**  
Courtesy of <http://www.mio.com>

### **3.18.7 GPS Error Boundaries**

The main GPS error source is due to inaccurate time-keeping by the receiver's clock. Microwave radio signals travelling at the speed of light from at least three satellites are used by the receiver's built-in computer to calculate its position, altitude and velocity. These small discrepancies between the GPS receiver's onboard clock and GPS time, which synchronizes the whole global positioning system, mean distances calculated can implicate false readings. There are two solutions to this problem.

- The first would be to use an atomic clock in each receiver.
- The second is to use some mathematical equations to account for the time-keeping error based on how the signals from three or more satellite signals are detected by the receiver, which essentially allows the receiver to reset its clock.

Thus, the second option is used due to the low costs by manufactures. Intrinsic error source in GPS associated with the way the system works. When the GPS receivers analyze three signals from satellites in the system and work out how long it has taken each signal to reach them. This allows them to carry out a trilateration calculation to pinpoint the exact location of the receiver.

The signals are transmitted by the satellites at a specific rate. Unfortunately, the electronic detector in standard GPS devices is accurate to just 1 percent of a bit time. This is approximately 10 billionths of a second (10 nanoseconds). Given that the GPS microwave

signals travel at the speed of light, this equates to an error of about 3 meters. That means the standard GPS cannot determine position to greater than 3-metre accuracy. More sophisticated GPS receivers used by the military are ten times more accurate to 300 millimeters.

Other errors arise because of atmospheric disturbances that distort the signals before they reach a receiver. Reflections from buildings and other large, solid objects can lead to GPS accuracy problems too. There may also be problems with the timekeeping accuracy and the data onboard a satellite. These accuracy problems are circumvented by GPS receivers which endeavor to lock on to more than three satellites to get consistent data.

### **3.19 Wireless Local Area Networking (Wi-Fi)**

Wireless Local Area Network or Wi-Fi/Wi-Fi is a technology with devices networks in the IEEE 802.11 standards. It has been trademarked by the Wi-Fi Alliance that certifies products that have access to successfully operate with the network. Devices that use Wi-Fi technology are considered compatible devices can connect to the internet via WLAN network and Wireless access point. These access points have a range on average about 20 meters (66 feet) indoors and a greater range outdoors. Hotspot coverage can be as small as a single room with walls that block radio waves, or a large as many square kilometers with overlapping access points.

Wi-Fi generally has uses the 2.4 GHz Ultra High Frequency (UHF) and 5 GHz Super High Frequency of Industrial, Scientific and Medical Radio Bands (SHF ISM). Having no physical connections, it is more vulnerable to attack wired connection, such as Ethernet.

#### **3.19.1 Wi-Fi Background**

In 1991, NCR Corporation with AT&T Corporation invented the precursor to 802.11, intended for use in cashier systems. The first wireless products were under the name WaveLAN. They are the ones credited with inventing Wi-Fi. The name Wi-Fi, commercially used at least as early as August 1999, was coined by the brand-consulting firm Interbrand. The Wi-Fi Alliance had hired Interbrand to create a name that was "a little catchier than 'IEEE 802.11b Direct Sequence. Wi-Fi nodes operating in ad-hoc mode refers to devices talking directly to each other without the need to first talk to an access point (also known as base station). Ad-hoc mode was first invented and realized by Chai K. Toh in his 1996 invention of Wi-Fi ad-hoc routing, implemented on Lucent WaveLAN 802.11a wireless on IBM ThinkPad's over a size nodes scenario spanning a region of over a mile. The success was recorded in Mobile Computing magazine and later published formally in IEEE Transactions on Wireless Communications.

**Table 19: Comparison of 2 Different GPS Modules**

	FPGMMOPAH	GP-20U7
Satellites	22 tracking, 66 searching	22 tracking, 56 searching
Antenna Size	15mm x 15mm x 4mm	18.4mm x 18.4mm x 4mm
Update Rate	1 to 10 Hz	350 $\mu$ A
Position Accuracy	3 meters	2.5 meters
Velocity Accuracy	0.1 meters/s	0.1 meters/s
Warm/Cold Start	34 seconds	29 seconds
Acquisition Sensitivity	-145 dBm	-148 dBm
Tracking Sensitivity	-165 dBm	-165 dBm
Maximum Velocity	515m/s	515m/s
Vin Range	3.0-5.5VDC	3.3VDC
Operating Current	25mA tracking, 20 mA current draw during navigation	30mA tracking, 20 mA current draw during navigation
Output	9600 baud default	9600 baud default
PRN	210	-
Jammer Detection	Yes	-
Cost	\$39.95	\$15

The IEEE 802.11 standard is a set of media access control (MAC) and physical layer (PHY) specifications for implementing wireless local area network (WLAN) computer communication in the multiple different frequency bands 2.4, 3.6, 5, and 60 GHz. The standard and amendments provide the basis for wireless network products using the Wi-Fi brand. While each amendment is officially revoked when it is incorporated in the latest version of the standard, the corporate world tends to market to the revisions because they concisely denote capabilities of their products. As a result, in the marketplace, each revision tends to become its own standard.

To connect to a Wi-Fi LAN, a computer must be equipped with a wireless network interface controller. The combination of computer and interface controller is called a station. For all stations that share a single radio frequency communication channel, transmissions on this channel are received by all stations within range. Wi-Fi technology may be used to provide Internet access to devices that are within the range of a wireless network that is connected to the Internet. The coverage of one or more interconnected access points (hotspots) can extend from an area as small as a few rooms to as large as many square kilometers. Coverage in the larger area may require a group of access points with overlapping coverage. Routers that incorporate a digital subscriber line modem or a cable modem and a Wi-Fi access point, often set up in homes and other buildings, provide Internet access and internetworking to all devices connected to them, wirelessly or via cable.

Similarly, battery-powered routers may include a cellular Internet radio modem and Wi-Fi access point. When subscribed to a cellular data carrier, they allow nearby Wi-Fi stations to access the Internet over 2G, 3G, or 4G networks using the tethering technique. Many smartphones have a built-in capability of this sort, including those based on Android, BlackBerry, Bada, iOS (iPhone), Windows Phone and Symbian, though carriers often disable the feature, or charge a separate fee to enable it, especially for customers with unlimited data plans. "Internet packs" provide standalone facilities of this type as well, without use of a smartphone; examples include the MiFi- and WiBro-branded devices. Some laptops that have a cellular modem card can also act as mobile Internet Wi-Fi access points.

A wireless access point (WAP) connects a group of wireless devices to an adjacent wired LAN. An access point resembles a network hub, relaying data between connected wireless devices in addition to a (usually) single connected wired device, most often an Ethernet hub or switch, allowing wireless devices to communicate with other wired devices. Wireless adapters allow devices to connect to a wireless network. These adapters connect to devices using various external or internal interconnects such as PCI, miniPCI, USB, ExpressCard, Cardbus and PC Card.



**Figure 35: Illustration of Wi-Fi with Connected Devices**  
 Courtesy of <https://3.imimg.com>

Wireless routers integrate a Wireless Access Point, Ethernet switch, and internal router firmware application that provides IP routing, NAT, and DNS forwarding through an integrated WAN-interface. A wireless router allows wired and wireless Ethernet LAN devices to connect to a (usually) single WAN device such as a cable modem or a DSL modem. A wireless router allows all three devices, mainly the access point and router, to be configured through one central utility. This utility is usually an integrated web server that is accessible to wired and wireless LAN clients and often optionally to WAN clients. Wireless network bridges connect a wired network to a wireless network.

A bridge differs from an access point: an access point connects wireless devices to a wired network at the data-link layer. Two wireless bridges may be used to connect two wired networks over a wireless link, useful in situations where a wired connection may be unavailable, such as between two separate homes or for devices which do not have wireless networking capability (but have wired networking capability), such as consumer entertainment devices; alternatively, a wireless bridge can be used to enable a device which supports a wired connection to operate at a wireless networking standard which is faster than supported by the wireless network connectivity.

**Table 20: Comparison of 2 different Wi-Fi**

	ESP8266EX	ESP-WROOM-32
Wi-Fi Protocols	802.11 b/g/n	802.11 b/g/n
Frequency Range	2.4G-2.5G (2400M-2483.5M)	2.4G-2.5G (2400M-2483.5M) ~ 2.5 GHz
Tx Power	802.11 b: +20 dBm 802.11 g: +17dBm 802.11 n: +14 dBm	Not Given
Rx Sensitivity	802.11 b: -91 dBm 802.11 g: -75 dBm 802.11 n: -72 dBm	Not Given
Types of Antenna	PCB Trace, External, IPEX Connector, Ceramic Chip	Not Given
Peripheral Bus	UART/SDIO/SPI/I2C/I2S/I R Remote Control  GPIO/PWM	UART/SDIO/SPI/I2C/I2 S/IR Remote Control  GPIO/PWM
Operating Voltage	3.0~3.6V	2.2 ~ 3.6V
Operational Current	80mA	80 mA
Security	WPA/WPA2	WPA/WPA2/WPA2-Enterprise/WPS
Network Protocols	IPv4, TCP/UDP/HTTP/FTP	IPv4, IPv6, SSL, TCP/UDP/HTTP/FTP/ MQTT
Price	\$9.99	\$8.95

### **3.19.2 Wi-Fi Security**

Wireless network security is its simplified access to the network compared to traditional wired networks such as Ethernet. With wired networking, one must either gain access to a building (physically connecting into the internal network), or break through an external firewall. To enable Wi-Fi, one merely needs to be within the range of the Wi-Fi network. Most business networks protect sensitive data and systems by attempting to disallow external access. Enabling wireless connectivity reduces security if the network uses inadequate or no encryption.

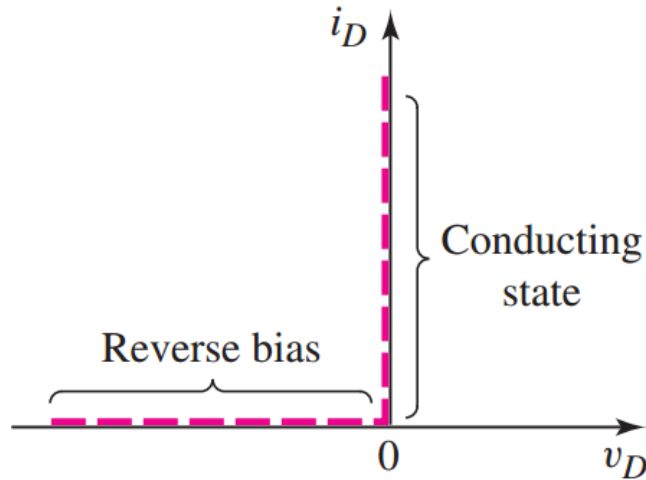
Wi-Fi Protected Access encryption (WPA2) is considered secure, provided a strong passphrase is used. A proposed modification to WPA2 is WPA-OTP or WPA3, which stores an on-chip optically generated one time pad on all connected devices which is periodically updated via strong encryption then hashed with the data to be sent or received. This would be unbreakable using any (even quantum) computer system as the hashed data is essentially random and no pattern can be detected if it is implemented properly. Main disadvantage is that it would need multi-GB storage chips so would be expensive for the consumers.

Wired Equivalent Privacy (WEP) encryption was designed to protect against casual snooping but it is no longer considered secure. Because of WEP's weakness the Wi-Fi Alliance approved Wi-Fi Protected Access (WPA) which uses TKIP. WPA was specifically designed to work with older equipment usually through a firmware upgrade. Though more secure than WEP, WPA has known vulnerabilities.

### **3.20 Diodes**

Diodes are used in many applications, from solar power generation, frequency mixing in radio frequency communications, and AC-to-DC power conversion. Diodes are electrical components that control the direction of the flow of current and prevents this flow from going in the opposite direction by acting as a block. A diode has two polarized terminals: one is called the anode and the other is the cathode. The anode is the positive end of a diode while the cathode is the negative end of the diode. Current flows from the anode to the cathode.

An ideal diode's primary function is to perform like a precise conductor when current flows forward from the anode to the cathode and like an insulator so that no current can flow from the cathode to the anode. The relationship between the voltage and current can be seen in the image below. Ideal diodes have two operational modes: forward-biased and reverse-biased. The graph in Figure 36 shows when the voltage is negative, the diode is reverse-biased. This means the diode is turned off, current is zero because current cannot flow, and the diode performs like an open circuit. When the voltage is zero or becomes non-negative, the diode is forward-biased. The diode turns on, current conducts and increases to an infinite amount, and the diode performs like a short circuit.



**Figure 36: The Voltage and Current Relationship of an Ideal Diode**  
**Courtesy of Microelectronics Circuit Analysis and Design**

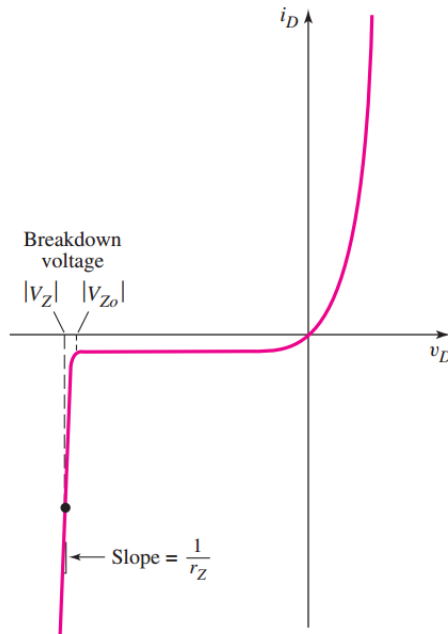
In applicable cases, diodes are not ideal because of a number of factors. Some diodes, depending on the material can have forward resistances and use some power when it is forward-biased. Applicable diodes have similar characteristics as the ideal; however, one of the biggest differences is that applicable diodes operate in three modes: forward-biased, reverse-biased, and breakdown.

A diode is forward-biased when the voltage across it is positive and the voltage is greater than the forward voltage. Depending on the material, diodes can have a barrier potential and forward resistance that it takes into consideration. As a result, the forward voltage is the set voltage where the current becomes significant. In diodes made from silicon material, the forward voltage is 0.7 volts while a diode made from germanium is 0.3 volts. Once it surpasses the forward voltage, the diode is turned on and current flows exponentially.

A diode is reverse-biased when the voltage is less than the forward voltage and greater than the breakdown voltage. This voltage can positive and negative, depending on the value of the forward voltage. The diode is turned off and the flow of current is blocked. However, a very small amount of current is able to flow back through the diode in the direction of the cathode to the anode.

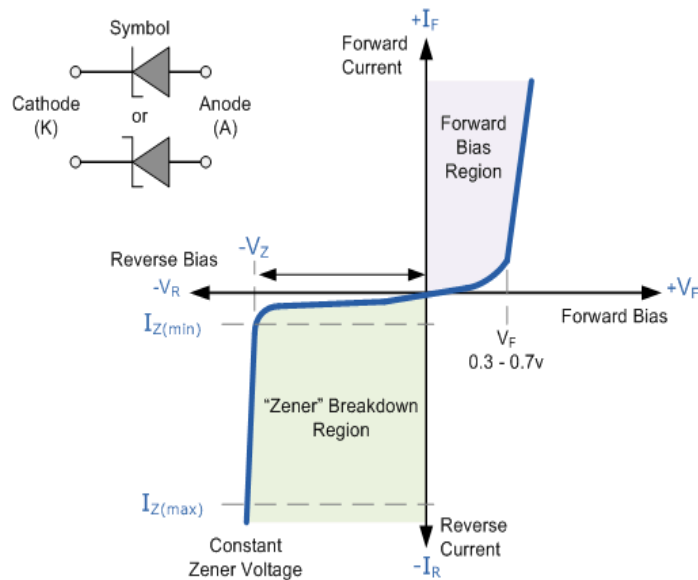
The breakdown mode in a diode is when the voltage applied across it is immensely negative. As a result, current flows in the reverse direction, from the cathode to the anode in large amounts.





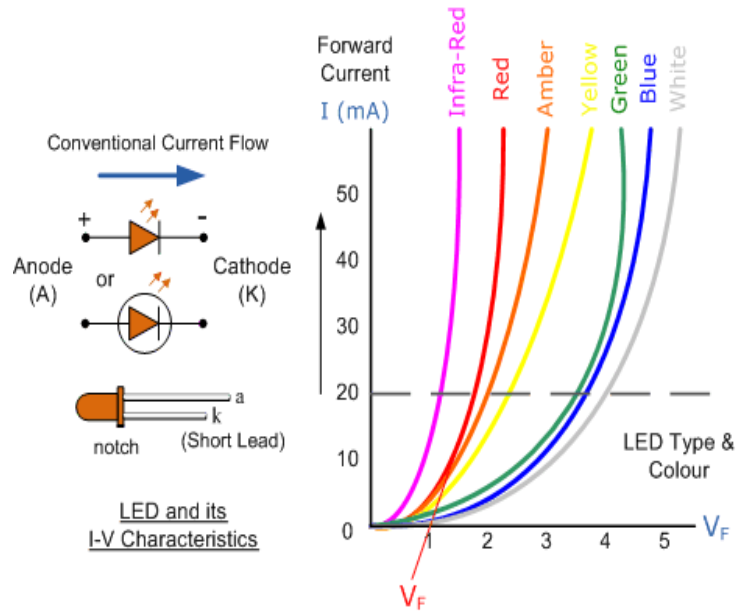
**Figure 37: Voltage and Current Relationship of an Applicable Diode**  
 Courtesy of Microelectronics Circuit Analysis and Design

There are many types of diodes and the main types are Zener, light-emitting, and Schottky. A Zener diode a semiconductor diode allows current to flow from the anode to the cathode. However, Zener diodes allow current to flow reversely, once it reaches a voltage known as Zener voltage. This voltage is a very specific breakdown voltage can be as low as -24 volts. The image in Figure 38 gives a visual of the relationship of the current and voltages.

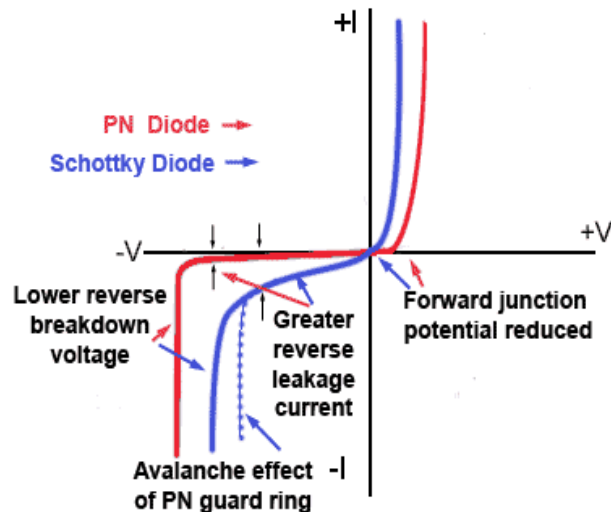


**Figure 38: Voltage and Current Relationship of a Zener Diode**  
<http://www.electronics-tutorials.ws>

A light-emitting diode, also known as LED, is a semiconductor diode that allows current through one direction. An LED is very similar to a general diode; however, the LED has a higher required forward voltage so that the light can emit. This forward voltage can range from 1.2 volts to 4 volts, depending on the color that the LED produces. Infra-red has the lowest forward voltage while the color white has the highest forward voltage. The image in Figure 39 shows the relationship between the voltage and the current.



**Figure 39: Voltage and Current Relationship of an LED**  
 Courtesy of <http://www.electronics-tutorials.ws>



**Figure 40: Voltage and Current Relationship of a Schottky Diode**  
 Courtesy of <http://www.electronics-tutorials.ws>

A Schottky diode is a semiconductor diode that is formed with another metal. This diode has a smaller forward voltage than a general diode, ranging from 0.15 volts to 0.45 volts.

The images below show the graphs of the relationship between the voltage and current. The image in Figure 40 below shows the voltage and current relationship of the Schottky diode compared to a general diode.

The main types of diodes were compared to determine the best diode for the Bioelectric Smartwatch.

**Table 21: Comparison of Different Types of Diodes**

Type of Diode	General Diode	Zener Diode	LED	Schottky
Forward Voltage (V)	0.3	0.65	1.2- 3	0.15-0.45
Breakdown Voltage (V)	Low	-24 to -3	Low	Low

Ultimately, it was decided that a general diode would be used. Two types of diode were researched and a comparison of their characteristics can be seen in Table 23.

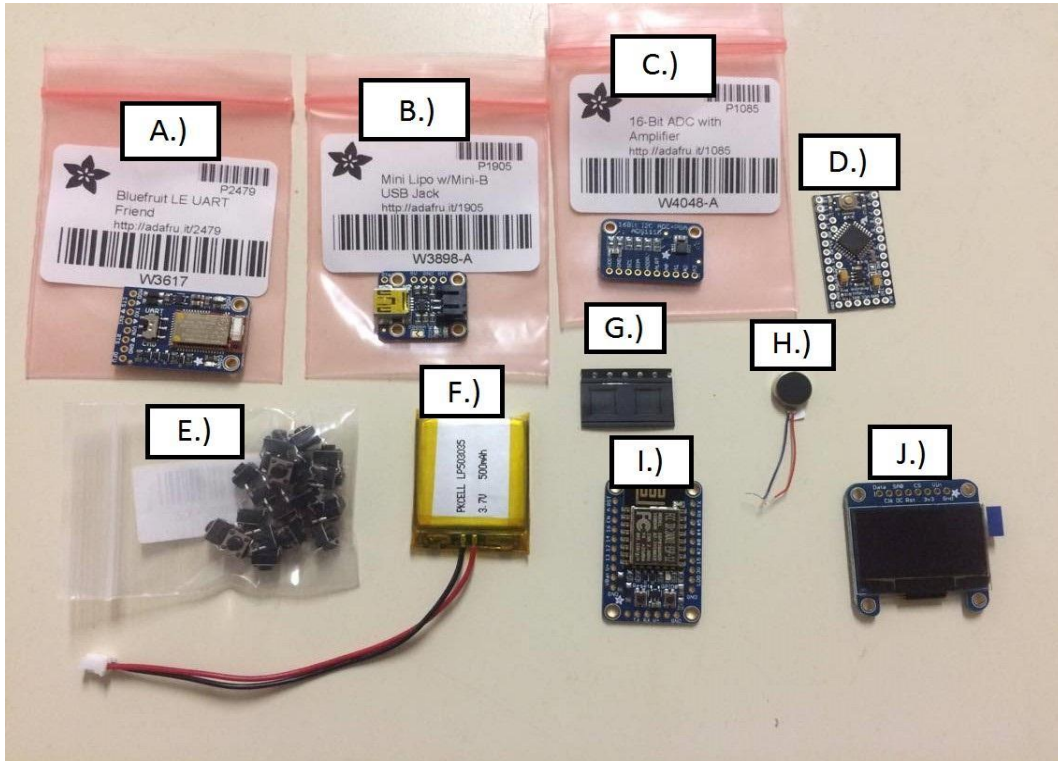
**Table 22: Comparison of 2 Diodes**

Name	1N4148	1N4454
Company	Digi-Key	Mouser Electronics
Max. Forward Voltage (V)	1	1
DC Forward Current(mA)	300mA	600
Breakdown Voltage (V)	75-100	75
Max. Reverse Current( $\mu$ A)	5	100
Reverse Recovery Time (ns)	4	4
Price	\$0.10	\$0.10

The type of diode that will be used in the Bioelectric Smartwatch is the 1N4148 diode because of its availability. This diode has a fast switching speed and can be used for rectification purposes. For the Bioelectric Smartwatch, the diode will prevent sudden inductive voltage spikes. In a circuit when the connections are broken, a high voltage pulse can occur. Thus, a voltage spike can occur. To prevent this spike from occurring and from causing possible damages to the rest of the components, a diode is placed in parallel to the inductive load so the current flow through the inductor is not blocked. This will allow current to dissipate over time.

### 3.21 Ordered Components

The electrical components to create the smart watch were ordered, and most have arrived. The arrival of the components means that testing can be conducted, and bread boarding can be conducted before the PCB is designed.



**Figure 41: Smartwatch Ordered Components**

The components ordered are listed below:

- A.) Bluetooth module
- B.) Lithium battery charge controller
- C.) ADC
- D.) Arduino Pro Mini Microcontroller
- E.) Tactile switches
- F.) 3.7V lithium battery
- G.) AFE4490
- H.) Vibrating motor
- I.) GPS module
- J.) OLED screen

One thing to note is that not all of the components are pictured, because not all have arrived.

## **3.22 Senior Design 2 Changes**

This section highlights major changes that took place at the end of Senior Design 2. Some of the topics that are discussed are based on the components that may have changed and the way things were implemented after further research was done.

### **3.22.1 Temperature Sensor**

The temperature sensor was not implemented in the final smartwatch design. Issues arose when trying to implement the LIS3DH component. Temperature readings from this device proved to be inaccurate and troubleshooting did not mitigate any issues. The team decided it would be best to remove the temperature sensor altogether and focus on the successful integration of the rest of the peripherals.

### **3.22.2 Voltage Regulator**

In Senior Design 2, it was discovered that an additional voltage regulator would be needed to power the pulse sensor and the ATmega2560. Originally, the 3.3 voltage regulator was going to be used; however, with a 3.3 volt input going into the pulse sensor, the pulse readings were incorrect. As a result, the pulse sensor was isolated from the rest of the components and a power supply was used to show that the sensor worked better at a higher voltage. It was also decided that the ATmega2560 would also be powered at a higher voltage. Upon further research, a NCP1402 boost converter was used as a step up 5 voltage regulator. Now the configuration of the power system has the voltage from the battery splitting off into the motor, 3.3 voltage regulator, and the 5 volt regulator.

### **3.22.3 Push Buttons**

Originally, the Bioelectric Smartwatch was going to have a four button configuration. Throughout the design process, the group realized that only three buttons were needed to carry out the functions of the device. Button one is the emergency button. When pressed and held, the emergency beacon sends the user's location to assigned/authorized personnel. Button two is the power button. Once the button has been pressed and held down, the watch turns off. If the button is pressed once, the watch will turn on and resume operation. Lastly, button three is screen toggle button. This button cycles from the home screen to the health data screen.

### **3.22.4 Accelerometer**

The accelerometer component that was in the original plans for the Bioelectric Smartwatch was the LIS3DH. In Senior Design 2, the accelerometer component was changed to the ADXL345. This was because the LIS3DH was an obsolete part. Also, the ADXL345 has slightly better resolution.

### **3.22.5 Data Converter**

Data converters were not used in the final Bioelectric Smartwatch. Each peripheral component had a converter integrated into its chip so this part was unnecessary.

### **3.22.6 Microcontroller**

The Raspberry Pi 3 was used in the prototyping portion of the project. The chip on the Raspberry Pi 3, the Broadcom BCM2835 proved to be difficult to test out the peripherals used in the watch so Arduino boards were considered. The ATmega328 was initially chosen however, this chip did not have enough memory. The team decided to choose the ATmega2560 because it has eight times the amount of flash memory as the ATmega328, it's compatible with the other peripherals, and it has enough input/output pins.

### **3.22.7 Watch Shell and Band**

The material used for the final watch was a woven material with Velcro to secure the watch in place. Due the watch being unisex, it was decided that the watch needed to be adjustable for different wrist sizes. The straps can be easily removed without having to do much alterations like a traditional watch.

### **3.22.8 Wireless Local Area Networking (Wi-Fi)**

After consideration and implementation of the smartwatch device, the team decided to move forward with Bluetooth for communication purposes. Due to the size constraints of the PCB, only one communication device would be needed. The Bluetooth module is low powered and with Bluetooth, the team removed the constraint of having to be connected to the internet to send data to the device.

## **4.0 Related Standards and Design Constraints (IEEE)**

Standards define characteristics of a product, process or service, such as dimensions, safety aspects and performance requirements. Standards play a very important role in the process of essentially all designs. There are quite a few standards that apply to design of the Bioelectric Smartwatch. The standards utilized in our design process will be collected from the Institute of Electrical and Electronics Engineers (IEEE) Standards Association. The Institute of Electrical and Electronics Engineers (IEEE), is a professional association geared towards the educational and technical advancements of electrical engineering, telecommunications, computer engineering, and allied disciplines, develops standards to maximize the reliability of materials, products, methods, and services that people use daily.

### **4.1 Related Standards**

For this project, many health measurements will be acquired. As a result, many of the related standards deal with making sure that regulations are enforced and that protocols will be taken into consideration in the design of the Bioelectric Smartwatch. The related health standards created by IEEE will be acknowledged below to prevent any health and safety issues from occurring.

There are several organizations in which develop and provide standards. Some of the organizations are The American National Standards Institute (ANSI) and NBS: National Bureau of Standards, just to name a few. Standards yield a set of requirements in which assist in the connection of one system to another.

Additional standards that are considered for the design and production of the Bioelectric Smartwatch are the IPC standards. The IPC is an administration in which links electronic industries. The IPC is authorized by an organization which is known worldwide. The organization is The American National Standards Institute (ANSI). The American National Standards Institute well known for their standards within the industry of electronics. Their standards are broadly accepted worldwide. The IPC develops standards industry wide for printed circuit boards (PCB's), design, assemble, development, and plenty other aspects. Although not many of the standards developed by the IPC impact us directly for the design of the Bioelectric Smartwatch. These standards do however impact the manufacturers of the elements utilized in the design of the Bioelectric Smartwatch. If these standards did not exist for manufacturers, components needed for our design may not operate correctly, or might not even exist. That being the case, while these standards do not directly impact the design of the Bioelectric Smartwatch, they do impact the device indirectly.

#### **4.1.1 IEEE Health Informatics**

The IEEE Std 11073-10441 is a portion of standards outlined for personal health device communication devices. This standard, in particular, establishes a normative definition of the communication between personal cardiovascular fitness and activity monitoring devices and managers in a manner that enables plug-and play interoperability. This standard was created so that users can be better informed in managing their health. Managers are defined as cell phones, personal computers, personal health appliances, and

set top boxes. Some key factors to take into consideration from this standard, especially regarding the Bioelectric Smartwatch measurements are heart rate and speed.

In the standard, heart rate is measured as a numeric value. Heart rates can be observed either as the maximum, minimum, or mean values for a session or sub session, or as an instantaneous value. The rate is a key indicator of physical exertion. In particular, the maximum observed heart rate is an important observation that might be used to calculate the VO<sub>2</sub>max of a user. VO<sub>2</sub>max, also known as maximal oxygen consumption, is the maximum rate of oxygen consumption as measured in exercise that increases intensity over time. With activity intensity, calculations can be made to find VO<sub>2</sub>max by multiplying the maximum recommended heart rate by 0.70. Another calculation that can be made is the maximum recommended heart rate which can be given by the estimation:

$$\text{Maximum recommended heart rate} = 220 - \text{age.}$$

Where age can be inputted manually by the user. The maximum recommended heart rate can be useful in providing context for the other values like the maximum, minimum, and mean observed heart rates achieved during an exercise session.

The Bioelectric Smartwatch will also have an accelerometer to inform the user about the number of steps taken. From the defined standard, this is a numeric measure called stride length. It defines this measurement as a measure of the distance covered in a single stride/step when walking or running. It is either captured as a minimum, mean, and maximum value over a session or sub session or as an instantaneous value. For the smartwatch, the accelerometer will be able to calculate the distance by using programmed algorithms and the vibrations that arise when a person moves their hands when walking. That swinging motion will then be able to show the distance.

Since the Bioelectric Smartwatch measures activity over a period of time called a session, information will be included about the date and time of the session, as well as the session duration and the activity that was measured during the session. The Bioelectric Smartwatch will provide measurements periodically as defined in section 12 of the standard where physical activity monitors are required to have some form of continuous monitoring sessions.

#### **4.1.2 IEEE Recommended Practice for General Principles of Temperature Measurements as Applied to Electrical Apparatus**

The IEEE Std. 119-1974 discusses guidelines and techniques for proper temperature measurement in applications. Accurate determination of the temperature can be within a degree or two may satisfy the need. The most general guideline mentioned is that when temperature is expressed in Celsius, it can be changed to Fahrenheit by using the equation below:

$$F = \frac{9}{5} \cdot (\text{temperature in Celsius}) + 32$$

The standard also states that when determining the technique to determine temperature, the factors below must be considered:



- 1) Accuracy of the measurement is required
- 2) Physical characteristics of the component be monitored
- 3) Accessibility of the part to be monitored
- 4) Permanency of instrumentation to be installed (short-term study/ life of the equipment installation)
- 5) Range of temperatures to be monitored
- 6) Location of readout device (local/remote)
- 7) Electrical potential of component being monitored

The image in Figure 42 shows the characteristics of the different temperature measurement techniques and special directions and precautions that need to be taken under consideration. The type of skin temperature sensor that will be used in this project go under temperature-sensitive materials. In this category, it is required that access to the surface being monitored is necessary.

For applications, such as the Bioelectric Smartwatch, the sensor should be in direct contact with the medium being monitored rather than separated from it by a wall, like a thermometer well. In section 3.6 of the standard, the procurement of constant or insignificant change in temperature reading is not necessarily adequate because of a process known as temperature equalization. This natural tendency is the flow of heat from regions where higher temperatures are to lower temperatures. Also, the time the sensor takes to measure this change in temperature needs to be taken into consideration. Because of this lag in measurement, it should be indicated to the user that a change in temperature occurs.

### **4.1.3 IEEE Standard for Rechargeable Batteries for Portable Computing**

IEEE Standard for Rechargeable Batteries for Portable Computing is a standard that is used as a guide for the design and manufacture of lithium-ion (Li-ion) and lithium-ion polymer (Li-ion polymer) rechargeable battery packs used for portable computing. In order to prevent battery system failure, this standard has provided clear approaches to design, test and evaluate a cell, battery pack and host device. System reliability is dependent upon the compliance of the provisions of the standard, including subsystem interface design responsibilities for each subsystem designer/manufacturer/supplier and the end user being properly educated.

Due to the fact that this standard covers rechargeable battery systems for portable computing, criteria has been established in order to ensure maximum operational performance in terms of design analysis for qualification, quality and reliability. The battery technologies covered within this standard only include Li-ion and Li-ion polymer but also mentioned are

- Battery pack electrical and mechanical construction
- System, pack, and cell level charge and discharge controls
- Battery status communications.

**Table 1**  
**Characteristics of Various Temperature-Measurement Techniques**

Technique	Working Temperature Range (°C)	Estimated Uncertainty*	Access Required to Monitor	Type Readout	Adaptable to Recording Instrument	Special Notes
Liquid-in-Glass Thermometer	-200 to 500	0.01 to 2 °C	yes	direct visual sight of column height	no	primarily for fluids and surface temperatures of solids except when well or other provisions are made
Filled-System Thermometer	-240 to 670	0.5 to 1% of span	no	mechanical linkage to pointer	unusual	
Bimetallic Thermometer	-130 to 540	0.5 to 1% of span	no	mechanical linkage to pointer	no	
Thermocouple Thermometer	-180 to 1480	0.1 to 2 °C	no	electrical millivoltmeter	yes	
Resistance Thermometer	-260 to 750	0.001 to 2 °C	no	electrical circuit to meter	yes	
Infrared-Radiation Thermometer Systems†	-50 to 150 (to 3000 in special applications)	0.2 to 5 °C	no	meter or visual image display	no	used principally for detection of hot spots in electrical equipment
Change in Resistance Method	-20 to 250	depends upon winding resistance and method used	access to winding terminals required	mathematical conversion of resistance to temperature	no	for obtaining average winding temperatures only; winding normally is deenergized
Temperature-Sensitive Materials	38 to 600 (to 1700 in special applications)	1% for fusible types 10 to 15 °C for pigment types	access to surface being monitored is necessary	sensitive material physical change	no	temperature-sensitive materials change physical appearance when their calibrated temperature is reached; material applied to surface to be monitored

\*Estimated uncertainty varies with type of device, scale of readout device, quality, and temperature being determined.  
†The characteristics given are those of instruments of importance in temperature measurements of electric apparatus.

**Figure 42: Image of Temperature Measurement Characteristics**  
Courtesy of <http://ieeexplore.ieee.org/document/29002/>

Furthermore, this standard focuses on and addresses:

- Qualification process
- Manufacturing process control
- Energy capacity and demand management
- Levels of management and control in the battery systems
- Current and planned lithium-based battery chemistries
- Packaging technologies
- Considerations for end-user notification as well.

Although this standard cannot guarantee protection or safety for battery users, it does provide recommendations for design analyses and certain testing procedures to ensure reliable user experience and operation of batteries in portable computing environments. It is the responsibility of the manufacturer/supplier to comply with such standards as well as the end user. It is also important to note that this standard cannot provide a complete guarantee against hazards to the end user (such as fire, explosion and leakage) as it can only contemplate reasonable intended use by the end user.

The battery pack will be designed in order to reduce hazards from contamination of electronic circuits by electrolyte from leaking cells. Minimizing hazards from foreign

objects and external sources of liquids will also be incorporated into the design of the battery pack and connector. Strategic implementations are included in the design of the circuit board and in the assembling process of the battery packs such as:

- Providing accurate runner spacing, soldering area size, and distance from each other, especially for power traces
- Providing adequate process control from solder balls, solder flashes, solder bridges, and foreign debris. Sufficient electrical, thermal and mechanical ratings will be applied to all components such as connectors, cables, tabs, insulators and circuit boards.

Whether the battery pack is installed in the device or removed from it, the output current will be limited in the event of an external short circuit. Battery packs will have methods to limit current, such as including protective circuits at the cell level and including connector structure to minimize the possibility of an accidental external short circuit of the battery terminals.

Over-temperature precautions will be incorporated to prevent hazards from occurring due to operation above maximum temperature or time limitations. Temperature ranges will be set based on surrounding environment temperature and the heat interactions between cell, battery pack and host device by the ranges recommended by the manufacturer/suppliers of the cells, battery packs and host devices. The battery pack alone will contain at least one thermal protection circuit or device independent of internal cell devices or mechanisms whereas the combination of cell, battery pack and host device will contain two. Upon temperature and time limitations being exceeded, the battery pack will shut down or use another protective action whereas the host device only may take action by shutting down or using another protective action.

The upper voltage and current limits of the cell, as specified by the manufacturer/supplier, will determine the maximum charging voltage and current in accordance with the agreement set by the cell, battery pack and host device manufacturers/suppliers. The charge control will be located in the battery pack and it will be a circuit or device in order to prevent overcharging. The combination of cell, battery pack and host device will control the charge if overcharging occurs by detecting the voltage of each cell block. In doing so, they will have at least three independent overcharge protection functions.

Similar to the precaution for overcharging, the minimum discharge voltage and current will be determined by the lowest voltage and current limit of the cell as specified by the cell manufacturer/supplier in order to prevent over-discharge.

In terms of overcurrent precautions, the battery pack will contain at least one overcurrent protect circuitry, such as a fuse or PTC resistor, to comply with the upper limit discharge current and time limitations set by the manufacturers/suppliers of the cells, battery packs and portable devices.

The focus of the design of the connector/terminal will be to prevent shorting by contact with a conductive object in order to minimize the chances of an accidental short circuit.

The final aspects of this standard are identifying the final underlying uses and functions of the battery. This standard allows us, the developers of the Bioelectric Smartwatch, to

understand all the functions and capabilities of the battery along with how it should be used to successfully be able operate it within the Bioelectric Smartwatch.

#### **4.1.4 Definitions and Concepts for Dynamic Spectrum Access**

The IEEE Standard Definitions and Concepts for Dynamic Spectrum Access: Terminology Relating to Emerging Wireless Networks, System Functionality, and Spectrum Management presents standard provides definitions and explanations of key concepts in the fields of spectrum management, cognitive radio, policy-defined radio, adaptive radio, software-defined radio, and related technologies. This standard goes further that straightforward definitions by elaborating upon terms in the circumstances of technology that utilize them. This standard also explains how these technologies develop new capabilities meanwhile supporting new prototypes of spectrum management such as dynamic spectrum access.

#### **4.1.5 Software Life Cycle Processes**

The 12207-IEEE Software Life Cycle Processes provides a general framework for the development of software. The standard explores the different aspects throughout the lifetime of a software from system. It covers the development, operation, maintenance, as well as the removal of software from a system. This standard overall:

- Specifies the Technical Management processes from ISO/IEC/IEEE 15288 that are required to be implemented for planning a systems engineering project
- Gives guidelines for applying the required processes.
- Specifies a required information item, a plan for the technical management and execution of the project that is to be produced through the implementation of the Project Planning process.
- Gives guidelines for the format and content of the required information item, and provides normative definition of the content of the information item that results from the application of these processes to that end. In this part of ISO/IEC/IEEE 24748 that plan for technical project management is termed the Systems Engineering Management Plan (SEMP).

#### **4.1.6 Systems Life Cycle Processes**

15288-2015-IEEE: Systems Life Cycle Processes standard demonstrates an engineering standpoint of a common structure of process descriptions for describing the life cycle of systems by defining a set of processes and related terms. These processes are applicable at any level in a system's structure and certain sets of these processes can also be applied throughout the life cycle for managing and performing the stages of a system's life cycle. To the benefit of an organization or a project, this standard also offers processes that support the definition, control and improvement of the system life cycle processes to be used for acquiring and supplying systems. Included within this standard are man-made systems that may be configured with one or more of the following system elements:

- Hardware
- Software

- Data
- Humans
- Processes
- Procedures
- Facilities
- Materials
- Naturally occurring entities

Providing a defined set of processes to ease communication among acquirers, suppliers and other stakeholders in the life cycle of a system while being applied to organizations as both acquirers and suppliers is the purpose of this standard. The processes can be used as a foundation for establishing business environments, including methods, procedures, techniques, tools and trained personnel.

This standard covers the importance of effective communication between a group of individuals as well as what the most beneficial way for us to reach the goal of our design. The standard kickoff is the initiation process. We achieved this criterion of the standard by completing our initial project document scope.

The next aspect of the standard is the development of the system concept. In this aspect of the standard, we mapped out the main goals for the project. After identifying the goals of the project the next aspect is the planning phase. Within the planning phase, a lot of uncertainty or disorder of the project is rectified. This is where we laid out certain goals and deadlines for the project such as deadlines for having parts ordered and when to begin testing components. After the planning aspect is the requirement analysis in which to delve into the specifications as well as the requirements as well as the scope of our project.

In order to achieve this, similar technologies to what we are using were researched to see what components and technologies would be most useful to us and why. Throughout this aspect of the standard is where we realized what components would be most suitable in the design of the Bioelectric Smartwatch. The next aspect is the development aspect. Within this aspect of the standard, physical components come into play. This is when we start to test as well as construct and layout integrations as well as testing of components. The final aspect of this standard is the results aspect. Within this aspect of the standard we map out complications and issues in which we encounter then go back to design a new aspect of the issue. We essential identify an issue and use new designing as well as trial and error to rectify the issue.

The final aspects of the standard are identifying the final underlying uses and functions of the device. This allows the user of the Bioelectric Smartwatch to understand all the functions and capabilities of the device along with how to operate it.

#### **4.1.7 IEEE Standard for Sensor Performance Parameter Definitions**

IEEE Standard for Sensor Performance Parameter Definitions standard introduces an established system of methods used in determining sensor performance. This standard satisfies the necessity that sensor performance is specified and will relieve non-scalable integration challenges. This standard outlines a collection of performance variables in

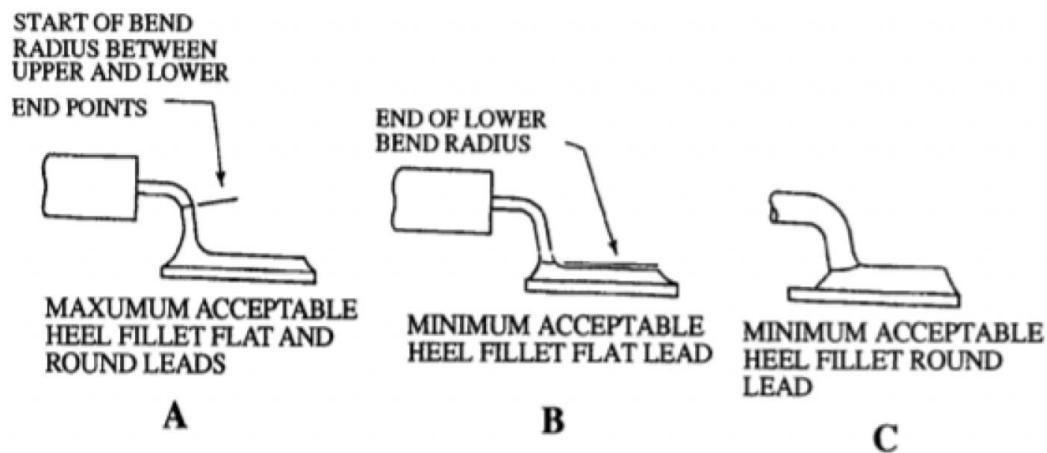
which distributions, units, and conditions for sensors. This standard outlines the accuracies in which the pulse sensor within the Bioelectric Smartwatch will utilize.

#### 4.1.8 IEEE Bluetooth Standard

The Bluetooth IEEE standard 802.15 will not have much impact on our design. This being because we will be utilizing already developed Bluetooth modules for use within our design. We will only be designing how we will incorporate the use of these already established components and how we will incorporate them within the infrastructure of the Bioelectric Smartwatch.

#### 4.1.9 NASA Standard for Soldering

NASA Technical Standard: Soldered Electrical Connections is a standard that was developed by the National Aeronautics and Space Administration (NASA). In this standard, NASA examine numerous significant factors which should be utilized in order for one's soldering technique to be deemed acceptable. In this standard, NASA utilizes numerous diagrams as well as tables in order to portray exactly just how contacts should appear when they are properly soldered. This standard incorporates multiple surface mount soldering approaches, such as, round-lead termination. It also includes through-hole soldering techniques as well. The figure below describes a few of the surface mount techniques for soldering.



**Figure 43: Formal Soldering Technique**  
Courtesy of <https://nepp.nasa.gov/index.cfm/5544>

#### 4.1.10 IEEE Wireless Local Area Network Assisted GPS in Seamless Positioning

The IEEE Wireless Local Area Network Assisted GPS in Seamless Positioning states

that, “Wireless Local Area Network (WLAN) is a new information access platform which can be used to achieve positioning, monitoring and tracking in wide area. Self-positioned of the network node is the basis and prerequisite for most applications, although the current popular Wi-Fi positioning technology is a position solution for WLAN series standard” [37]. This standard describes satellite navigation as well as positioning technologies. This standard also describes various calibration procedures as well as satellite positioning and navigation. Our Bioelectric Smartwatch utilizes this standard because our watch utilizes GPS for both outdoor as well as indoor.

#### **4.1.11 PCB Standard**

The IPC is an administration in which links electronic industries and has developed a Printed Circuit Board standard. The IPC is authorized by an organization which is known worldwide. The IPC gained its accreditation from the American National Standards Institute to develop standards. The Association of Connecting Electronic Industries creates standards that cover the assembly as well as the production requirements that is utilized within electronic equipment. Listed below are some printed circuit board (PCB) standards

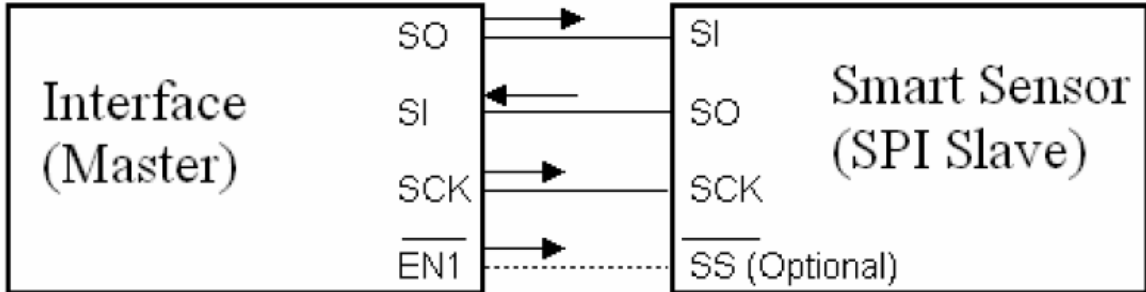
- The IPC 2615 establishes the standard for the Printed Circuit Board Dimensions and tolerances.
- The IPC-D-325A indicates the necessary documentation requirements needed for Printed Circuit Boards.
- The IPC-ET-652 indicates the necessary guidelines as well as requirements for Electrical Testing of Unpopulated Printed Circuit Boards.
- The IPC-2221A indicates the necessary general standard used within Printed Circuit Board Design.
- The IPC-6011 indicates the necessary general performance specification for Printed Circuit Boards.
- IPC J-STD-001ES indicates the necessary requirements utilized within soldering electrical and electronics fabrications.
- IPC J-STD-004B indicates the necessary requirements for soldering fluxes.

#### **4.1.12 IEEE Standard for I2C and SPI 1451.7**

The IEEE standard 1451.7 describes the smart transducer interface for sensors. This standard is created to make it possible to connect a multitude of transducers (sensors) in a network. The network may be wired, or wireless. This relates to our project, because it contains the standards for using SPI, and I2C communication with sensors. The sensors in the Bioelectric Smartwatch use both SPI and I2C communication methods.

The SPI (serial peripheral interface) standard describes that SPI is the method of sending data out of the SO (serial output) of one device into the SI (serial input) of the other. Each bit is sent serially, or one bit per clock cycle to make up a total of 8 bits. This is how information is exchanged between two devices that utilize SPI. It is common to use frequencies of 10kHz to 100Mhz for SPI, but this standard suggests 2Mhz. For SPI sensors, a chip enable (SS) pin is implemented to allow for a single master

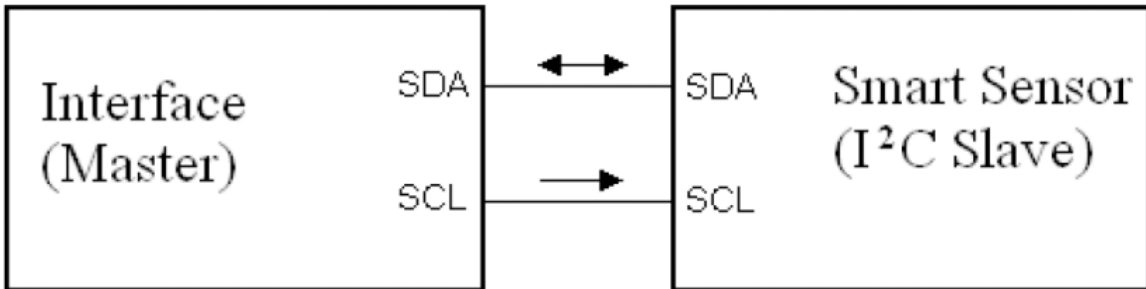
microcontroller to control multiple slave sensors. Figure 44 displays this relationship. SPI is the easiest method to communicate on serial busses. The hardware implementation of the master and the slave can be carried out with ease.



**Figure 44: SPI Standard Demonstration**  
 Courtesy of <http://ieeexplore.ieee.org/document/5494713/>

The next part of the IEEE 1451.7 standard describes the I2C (inter-integrated circuit) standard for interfacing sensors. I2C is also an option for most of the sensors in the project, and may be used for the accelerometer.

With I2C circuits, the bus only contains one clock line, and the input/output trace is combined into one trace. The master, or microcontroller, will control the clock to synchronize the data. The data being sent from the MCU to the sensor contains the address, so multiple sensors can be connected to the same input/output line.



**Figure 45: I2C Standard Demonstration**  
 Courtesy of <http://ieeexplore.ieee.org/document/5494713/>

I2C is a common bus communication protocol. The advantage of the I2C bus is that it only uses 2 wires to send and receive data. However, because it only uses two wires, it is more difficult to program the interchange of communication.

#### 4.1.13 Health Informatics Personal Health Device - 11073-10404-2010

In this standard pulse oximetry is described. This is pertinent, because the pulse sensor is the most difficult to implement and important part of the smartwatch.



Pulse oximetry analyzes the amount of SpO<sub>2</sub>, or amount of Oxygen saturated in the blood. The standard refers to measuring the pulse of the user. During moderate, or low stress activities, using pulse oximetry may not be sensitive and give either unrealistic or fluctuating measurements. “Modality” of the pulse measurements may be employed to gather more realistic data. Modality is an algorithm that smoothens the measurement data via averaging or by other means. This modality is also called “slow response.”

Pulse sensors will send measurements on a periodic base. They may send a measurement once every second. The standard also mentions that the pulse oximeter may send a data point every time that an acceptable value is measured, or converge on a “best value.” This best value technique is also called a “spot check.” The device does not simply show the first data point, but shows the “best” value.

This standard also mentions that while measuring the blood Oxygen levels is convenient, it is not the same as measuring the heart’s pulse directly. The heart needs to beat, and then needs to send blood to the artery, and create enough arterial pressure for the pulse sensor to register a measurement. This means that there can be more error within pulse oximetry. This also means that an ECG (electrocardiogram) may be more accurate than a pulse oximetry measuring device because the ECG directly measures the pulse of the heart by measuring the voltage across the heart. The heart pulsating produces an instant pulse indication with the heartbeat signal.

There are also multiple ways to use the blood Oxygen levels collected by pulse oximeter. To use Pulse Oximetry, at least one of the uses of blood Oxygen must be collected and sent to a data manager. The data can be stored on the device and sent later (hours or days depending on storage), or the data can be sent immediately to the manager. Either method constitutes a pulse oximetry design.

## **4.2 Design Constraints**

Any project or endeavor that a group of individuals, team, or company embarks on will have some challenges, which are also known as constraints. Design constraints are design decisions that sets limits on any project. These constraints anticipate potential problems that may arise and take into consideration other factors that may have a negative impact on the final design.

The major challenges of implementing a pulse sensor in a watch will be noise and position. Typically, pulse is measured from the hands, or finger tips, but our goal is to be able to read the pulse from the wrist. This means, that the group will need to find a way to obtain a steady pulse signal from the wrist by means of amplification, infrared device selection, or physical position in the watch. The user of the watch will also move around quite a bit; thus it will be difficult to get a steady signal. Noise can be introduced from the movement of the sensors, and the ambient light. This means that filters, and light isolation must be implemented to obtain a usable signal.

Though GPS technology has been around for a few years the only constraint is when there is no internet connection then the system would only have to rely on the closest cell tower

for calibration. If due our client possibly being in a remote location, it may interfere with smartwatch emergency alerts and pinpointing location in an emergency.

Another constraint is not getting enough participants to train and verify our Bioelectric Smartwatch, test usability of the different functions of the smartwatch, and accuracy of measured results. We must work together to really push ourselves to create a real novice medical device and contribute to the research community.

In addition to the challenges that we will fill in designing and building the Bioelectric Smartwatch, some other constraint factors need to be taken into consideration for this project. The main categories are listed below:

- Economic
- Environmental
- Ethical
- Health and Safety
- Social
- Time

#### **4.2.1 Economic and Time Constraints**

Economic constraints will limit the type of components used in the Bioelectric Smartwatch. Although this project will be funded by the members of the group, it is important to take costs in consideration to make this device a feasible and marketable product for potential consumers. Consequently, price, among other factors, has been a factor in picking the type of components used for this project. Another economic constraint is that currently, the market for body composition smartwatches has been going down. If this device were to be marketable for users, the main goal would be to present additional features that existing watches do not have.

One of the largest constraint of this project is time. Instead of completing Senior Design II in the fall when there are sixteen weeks in the semester, our group will complete Senior Design II in the summer. This summer semester only has about eleven weeks. This duration of time will include implementing and testing our design to ensure that everything is working properly and that time will be assigned for any issues that occur, Time will also be allocated in the event that components need to be reordered or any modifications made to the layout of the printed circuit board can be received and tested accordingly. As a result, it is important to practice time management and be strict on meeting deadlines in order to be successful.

#### **4.2.2 Environmental, Health and Safety Constraints**

Because the Bioelectric Smartwatch will perform health measurements, it is important to consider the health and safety of the user. Electrical components need to be properly insulated and covered to ensure that it doesn't pose a risk to the person wearing it.

An environmental constraint involves the wireless communication used in the Bioelectric Smartwatch. Although GPS technology has been around for a few years and has many advantages, it comes with slight setbacks. When there is no internet connection, the system would only have to rely on the closest cell tower for calibration. In the event that the user is in a remote location, it may interfere with the smartwatch's emergency alert system and make pinpointing their location difficult during an emergency.

Health concerns that may occur to design are skin irritation. The main causes of skin irritation are the belt and elevated parts of the sensor. Belt width and softness are extremely important for the prolonged use. Optical sensor features an elevated, dome like, structure to allow better contact with the skin. However, the sensor creates more pressure at the contact with the skin.

Wrists are not very convenient for physiological sensors, mostly because of the motion artifacts, access to the skin (e.g. hairy skin), or skin complexion darker skin provides less reliable measurements.

### **4.2.3 Ethical and Social Constraints**

The Bioelectric Smartwatch is advertised for anyone who is interested in monitoring their health. We must ensure that this product is user-friendly and adaptable to meet the user's needs. Our goal is to make this device not only easily available but secure.

One main social and ethical constraint is the accuracy of the health information. The Bioelectric Smartwatch will be worn on the wrist. Because of its placement, similar to wearable health monitoring devices on the market, the data that is collected is not necessarily of use to physicians. Most of these devices are not certified medical devices so physicians are skeptical to use the information that these types of devices record. In addition to meeting the accuracy standard as defined in section 4.1, external factors can also affect the accuracy of the device such as PCB layout or excessive movement. In order to ensure that there is transparency and that users are aware of all aspects of the Bioelectric Smartwatch; a disclaimer will be created.

### **4.2.4 Electrical Safety Constraints**

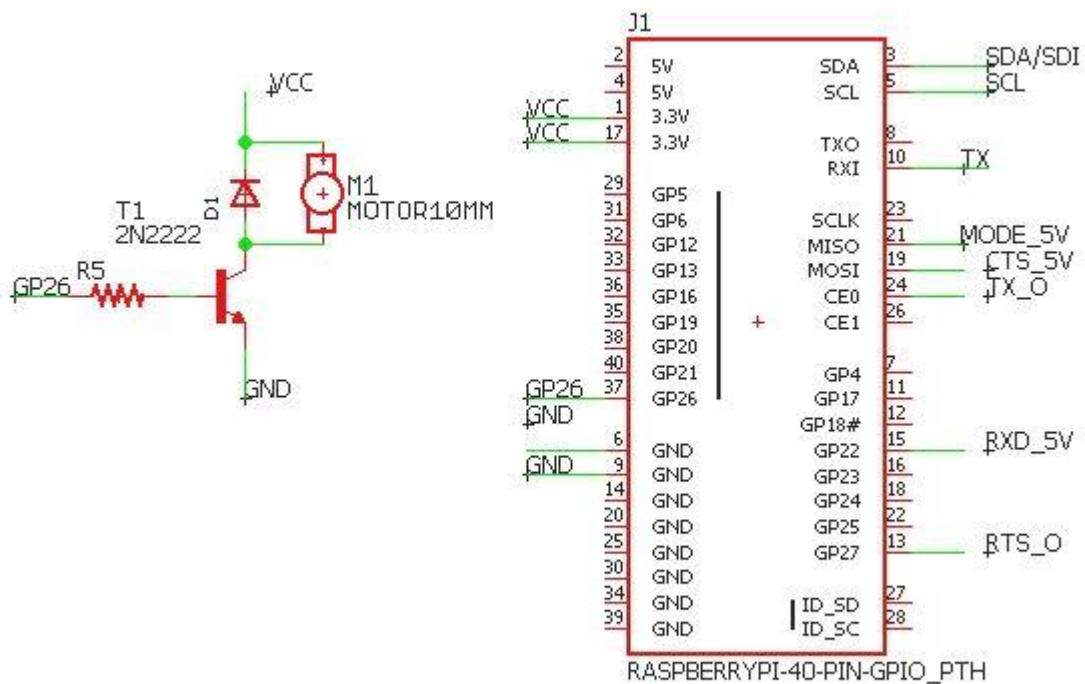
Because the Bioelectric Smartwatch will perform many tasks at once, it will rely heavily upon the proper operation to be safe for users. All components within the Bioelectric Smartwatch must be safe. These components must be safe for those designing as well as the users of the device. First and foremost, no wires should be exposed on any part of the device. Also, we must try our best to prevent short circuits. A short circuit could be detrimental to the device and can bring harm to the use of the Bioelectric Smartwatch. A short circuit can cause battery failure. This failure could in turn lead to an explosion of the battery as well as the device. These electrical safety constraints will be taken into consideration within the design as well as development of the Bioelectric Smartwatch to keep the developers out of harm's way, but most importantly the users of the device.

## 5.0 Project Design

The project design section is intended to describe the designs that will be implemented to allow the smart watch to function. The project's overall design will be broken down into subsystems to better analyze how the watch will be implemented, and how it will function.

### 5.1 Motor Design

The motor is one of the more simple parts of the smart watch. The motor will be used to bring the attention of the user to the watch's notifications. This means that the motor must vibrate enough to alert the user, without vibrating too much and creating unwanted noise. The motor used in the design is the Adafruit Mini Motor Disk because it is small enough to fit in the watch, was the cheapest option, and works with the voltage supply available.



**Figure 46: Motor Schematic**

The datasheet for the vibrating motor claims that it works with voltages from 2V-5V. Testing was conducted on the motor with the Agilent E3630A Triple Output DC Power Supply as the power supply. The power supply output voltage was increased until the motor produced just enough vibration to be felt by the hand. The motor began vibrating noticeably at 0.5V. The voltage was then increased to 3.7V to see if that was enough voltage to create sufficient voltage to alert the user, because the supply battery's voltage is 3.7V. The motor produced sufficient force to alert the user.

The schematic of the vibrating motor design is shown in Figure 46. The BJT base pin is connected to a general input/output pin on the microcontroller to throttle the motor. It only needs to be a general digital pin, because the voltage at the base can be a constant value. A resistance of  $5k\Omega$  is used in place of R5 to drop the output voltage from 3.5V to 0.8V at the base.

## 5.2 Power Design

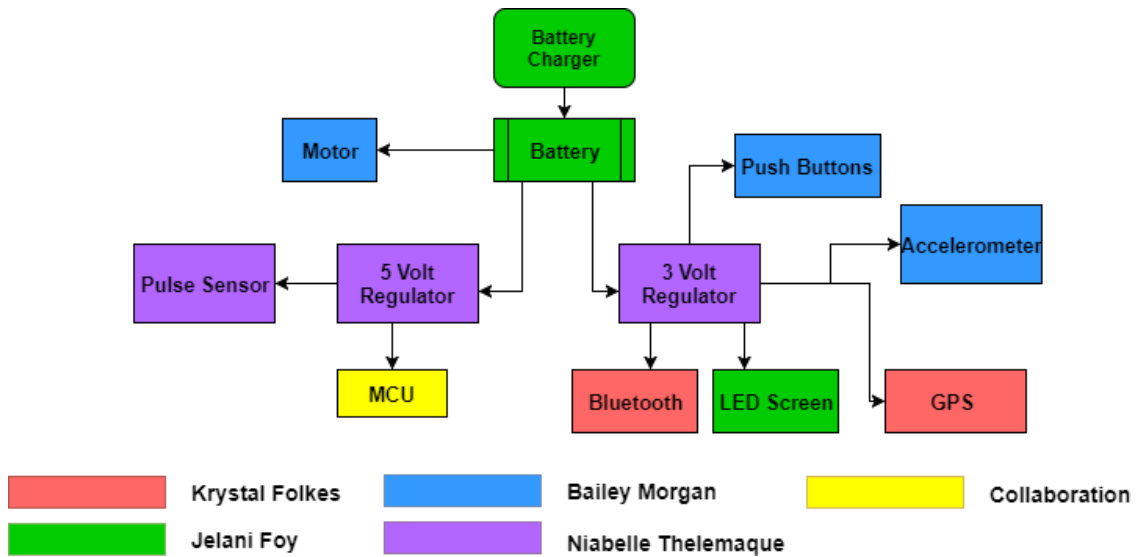
The power design of the watch is a crucial element to the success of the watch. The watch must be able to power many components simultaneously, while also having a long enough lifespan to satisfy the user. If this design is not properly designed, insufficient voltage could turn off components, overvoltage could damage components, and voltage fluctuations could cause bad performance of the device.

The watch is a portable device, thus when the watch is not being charged a lithium battery will act as a supply. The battery being used is a 3.7V, 500mAh battery. This battery will be connected to a charging circuit, and a voltage regulation circuit. While a battery is charging, and discharging, the voltage will fluctuate. This is not acceptable as an input for a circuit, because components like the AFE have sensitive inputs that can be affected by these fluctuations. This creates a need for a voltage regulation circuit that can keep the secondary components supplied.

The voltage regulator that will be used is a boost regulator that has linear down regulation capability. This regulator will keep the output at 3.3V, which will work with every component in the watch. The maximum voltage that can be supplied by the battery or the charger when it is fully charged is 4.2V. This regulator will down regulate up to 5V, so it will keep the components properly supplied even when the battery is charging. This is important if the user would like to turn on the device while it is turned on. The voltage regulator claims an efficiency of up to 90%, which is an excellent efficiency for this project.

The motor will not be regulated by the voltage regulator because it will reduce losses that are introduced by the power supply. Instead, the motor circuit will be directly supplied by the battery, and will not be a secondary power component. The motor is able to handle the full voltage of the battery; thus, it will not be necessary to regulate the voltage to the motor. Also, the difference in force output by the motor between 3.2 and 4.2V (operating voltage of the supply battery) is not noticeable to the user. The reason for choosing not regulate the motor's voltage is essentially to save power.

It can be seen in Figure 47 that the microcontroller, screen, analog to digital converter, AFE, temp sensor, Wi-Fi, and Bluetooth will all be receiving the 3.3V DC. Components were chosen strategically to have compatible input voltages, to minimize efforts on designing power supply circuits.



**Figure 47: Power Block Diagram**

### 5.2.1 Power Consumption

**Table 23: Device current consumption**

Component	Max Current Draw
Microcontroller	150 mA
Wi-Fi	215 mA
Bluetooth	50 mA
ADC	.15mA
Temp Sensor	.012 mA
Screen	200 mA
AFE	50 mA
Motor	100 mA
<b>Total</b>	<b>765 mA</b>

When considering what to power the smart watch, power consumption is the most important calculation. One must know how much power is being drawn to match the correct power supply. Data on current consumption can be found within the datasheet for each component, however, the amount of draw on each of these components can vary drastically depending on what the component is doing. Many of the components in the

watch can be drawing much more than their max, depending on what function that they carrying out and depending on what mode they are in (operational, rest, shutdown).

When calculating how much current a device draws, it is important to calculate the maximum power drawn to make sure that both the supply and the regulation can handle the current draw. Table 23 shows that the calculated maximum current draw from the watch components is 765mA if all of the components are working at their maximum at the same time. This obviously is not likely, nor will it be programmed to do so, but it is important to make sure that the upper bound is calculated to make sure that the correct battery and regulator are chosen.

The voltage regulator is rated to handle up to 1.2A of supply current. This seems to work with the voltage regulator, because the maximum draw is 765mA, but the voltage regulator is also not an ideal voltage regulator. The voltage regulator has an efficiency of upwards of 90%, but also as low as 70%. To calculate the current draw on the supply side of the voltage regulator, the formula below can be applied. If the efficiency of the regulator is 70%, then using the equation,

$$\text{Supply Current} = \frac{\text{Current Draw}}{\text{Efficiency}}$$

$$\text{Supply Current} = \frac{750mA}{0.7}$$

the efficiency is 1.07A. On the lower bound, the supply current could be as little as

$$\text{Supply Current} = \frac{750mA}{0.9}$$

which is 833 mA. Realistically, the supply current will be something between 1.07A and 833A, and both of these currents are below the rated 1.2A stated in the datasheet.

The battery chosen needs to be analyzed as well. The battery is a 3.7V, 500mAh battery. 500mAh is the amount of current that the battery can supply before it reaches its low voltage operational threshold. To see how long this battery will last before the watch shuts off with all components operating at maximum capacity, the formula

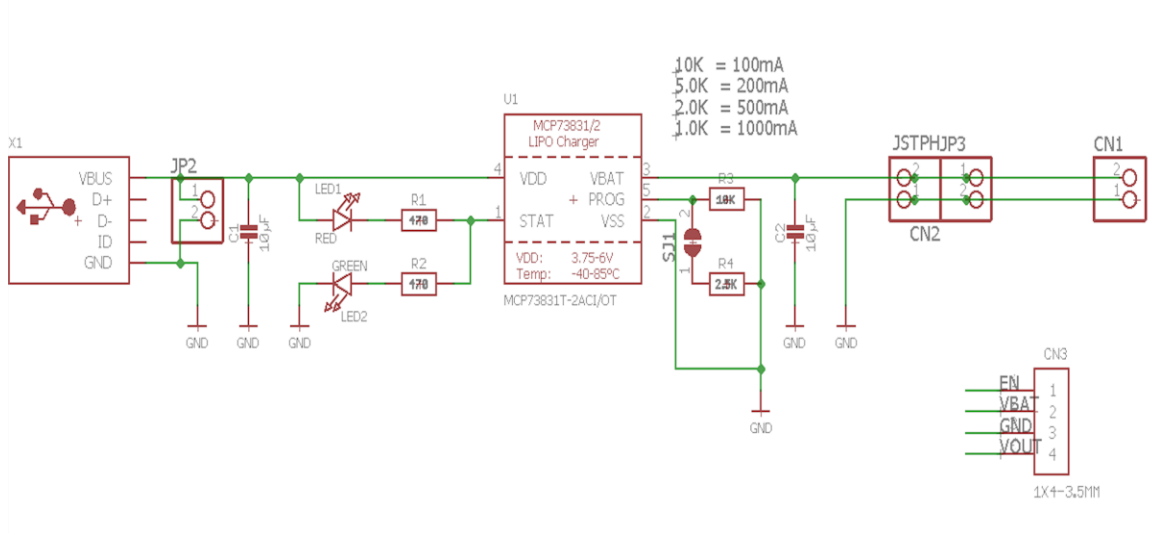
$$\text{time} = \frac{\text{capacity}}{\text{current draw}}$$

will be applied. In this case, the battery can last  $\frac{500mAh}{750mA}$ , which is 0.67 hours, or 40 minutes. After efficiency of the regulator is considered, the max time possible to attain from this battery is 36 minutes. This is reasonable, because the components in the watch either will be programmed to idle in rest mode, or will not be used constantly. If one's cell phone were able to use every feature at once, it would not last very long either. The watch will use much less current, and hopefully it can be reduced to 5% of its max current. At 5% of its max current, the watch will last  $\frac{500mAh}{37.5mA}$ , which is 13.3 hours.

## 5.2.2 Battery and Charging Design

Lithium-ion polymer (Li-Ion) batteries possess certain charging requirements so that the battery can be charged efficiently. The charger we are using within our design is the Adafruit Mini Lipo with mini USB jack charger. Efficiently charging the battery protects the battery, thus protecting the device in with the battery is supplying power to. Overcharging the battery may damage and or significantly lessen the overall lifetime of the battery. When charging this battery, it's important to keep the charge rate in mind.

The battery and battery charger will be attached to the regulator. The system of the regulator, battery and battery charger will work in unison to ensure that the components of the Bioelectric Smartwatch will receive the correct amount of voltage that will remain constant for each component so that no components are damaged.



**Figure 48: Battery Charging Design Schematic**

Charging of the battery is carried out in three stages:

1. Preconditioning charge
2. Constant-current fast charge
3. Constant-voltage trickle charge

This charger utilizes charge indicator LEDs. The indications of these LEDs are outlined in Table 24.



**Table 24: Battery Charger Indicators**

<b>Color</b>	<b>Indication</b>
Red	Battery is charging
Green	Charge cycle is complete
Both	Battery is damaged or is not plugged in

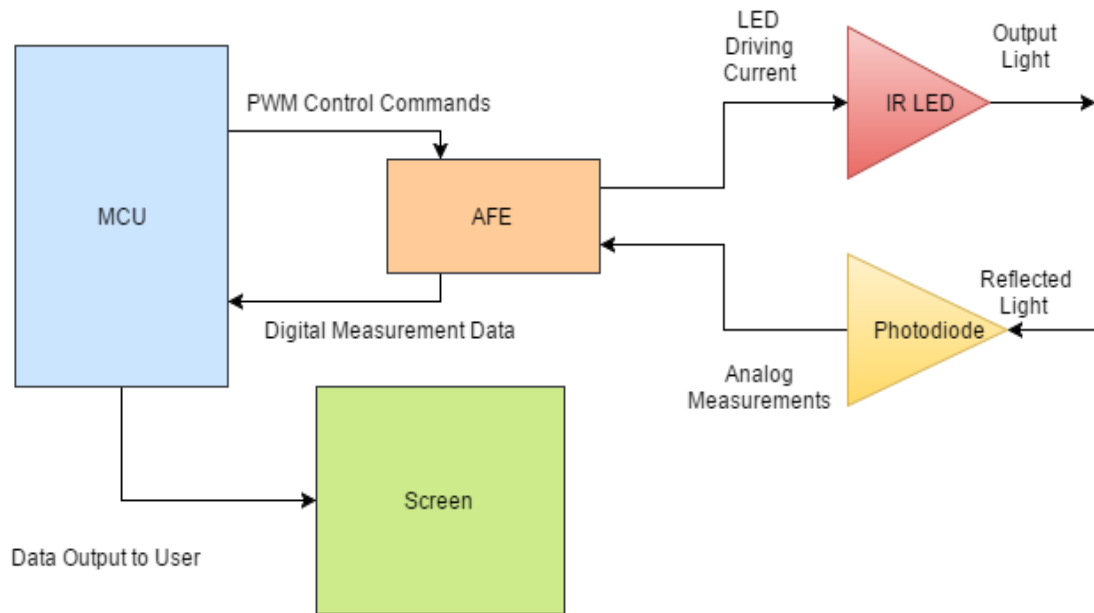
### **5.2.3 Voltage Regulator Design**

The main purpose of the voltage regulator is to regulate the power from the battery and maintain it at a certain voltage. A simple test will be done to ensure the voltage regulator was working properly and maintaining an output of 3.3 Volts. Only the three of the four pins on the voltage regulator will be used for the Bioelectric Smartwatch. The voltage regulator will be placed between the battery and the rest of the components used in the Bioelectric Smartwatch.

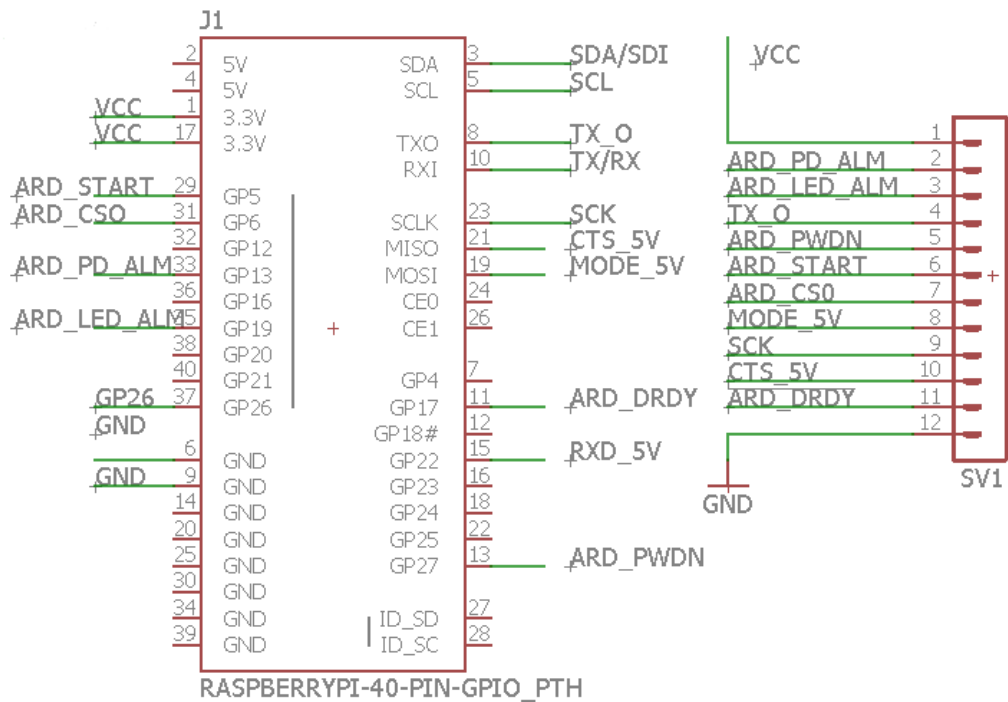
### **5.3 Pulse Sensor Design**

To main goal of the pulse sensor design is to feed coherent data to the microcontroller, that can then manipulate and send the data to the user in an understandable format. A few key functions must happen to accomplish this. The first is driving the LED with a current and voltage that is controlled by PWM. The second is obtaining the analog values from the photodiode. The third function that must be performed is filtering and amplifying the input analog waveform, because of induced noise from the surroundings. The last function that must be performed is analog to digital conversion of the data that is pulled from the photodiodes. This information is then passed serially to the microcontroller one bit at a time.

The components that were chosen to accomplish the task of measuring the user's pulse were the infrared LED and photodiode from Sparkfun, and the AFE 4490 from Texas Instruments, TI. The TI AFE takes much of the design work out of getting a working LED transmitting, because it comes with most of what is needed within one package. Contained within the AFE4490 is a trans impedance amplifier, gain stage, analog filter, analog to digital converter, digital filter, serial interface, timing controller, LED controller, and an oscillator. This means, that the design challenge of measuring the pulse will be in coordinating the PWM of the LEDs to output the correct frequency of light to accurately measure the blood flow of the user. Also, coordinating the serial communication between the microcontroller and the AFE will be done by trial.



**Figure 49: Pulse Sensor Communication Diagram**



**Figure 50: Pulse Sensor Schematic**

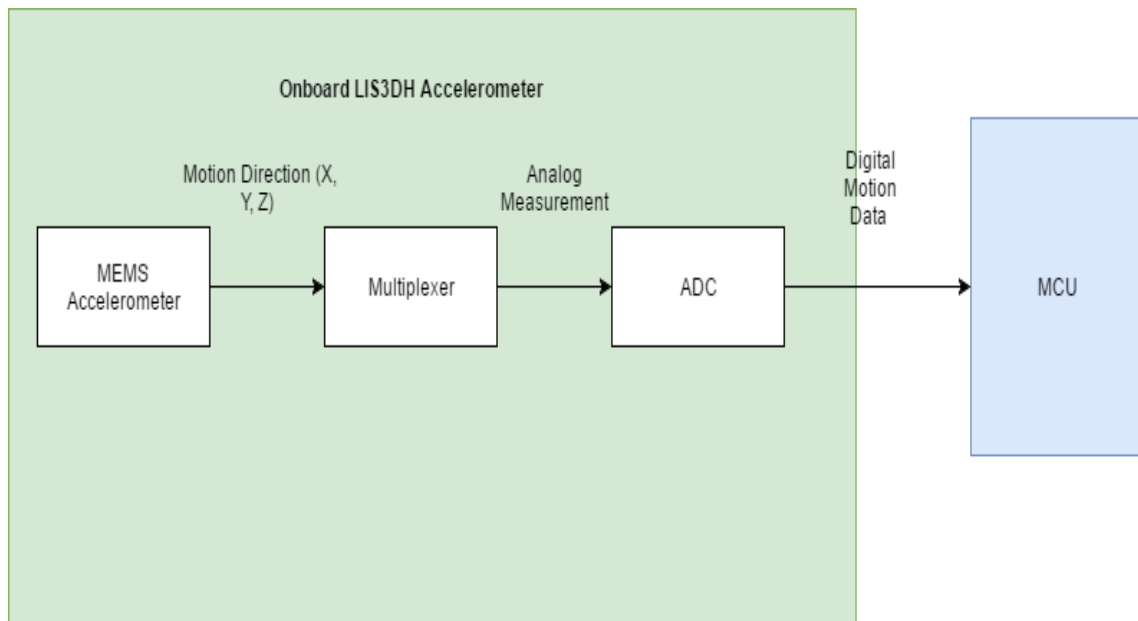
The design of the pulse sensor also includes activating the LED drivers and controlling how often the pulse is taken. The AFE has a significant current draw of 50mA when it is operating at maximum capacity, thus checking the user's pulse every minute will be sufficient in gathering relevant data. This smartwatch is not a precise fitness tracker that will track heart rate each second because the users will not need data that precise. Typically, that data is only necessary for knowing current physical effort during an interval training

workout.

Another design aspect of the pulse sensor is the power diagram. The AFE4490 takes two voltage supplies to properly function. The transmitting pin takes 3-5V DC, and the receive pin takes 2-3.6V DC. Both inputs overlap from 3-3.6V DC. The voltage regulator used for all of the components will provide 3.3V DC, thus wiring the voltage inputs in parallel and attaching to the output of the voltage regulator will be sufficient in powering the AFE chip.

The pin connections can be seen in Figure 50. The schematic shows the connections between the microcontroller and the AFE 4490 pulse sensor IC.

## 5.4 Accelerometer and Temperature Design



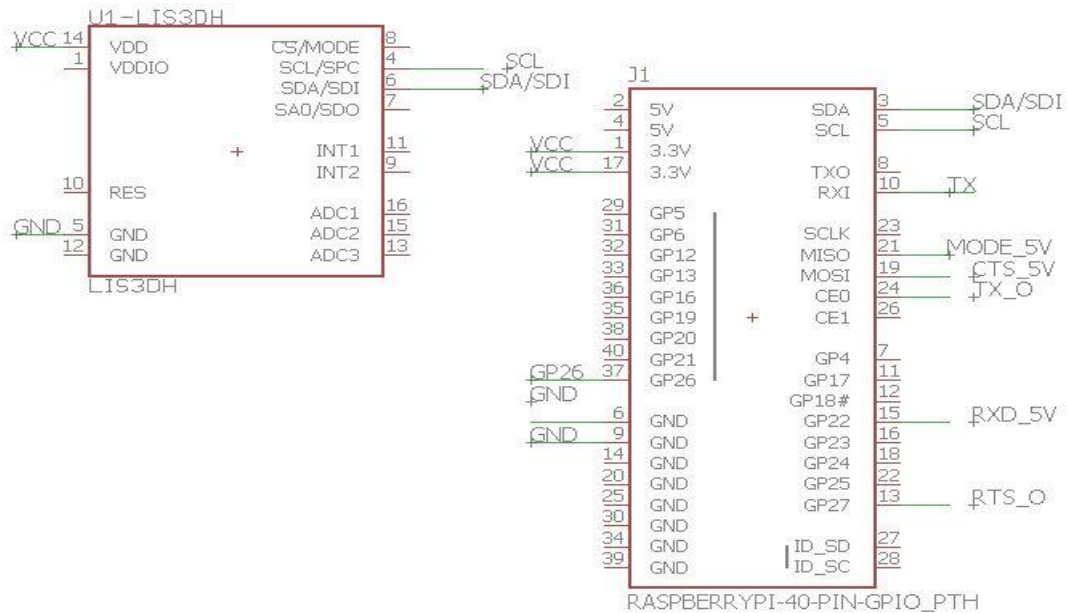
**Figure 51: Data flow diagram of LIS3DH**

The goal of the accelerometer is to sense whether the user is active, or at rest, and assist in tracking the movement of the user. The accelerometer will act as a switch that will send a signal to the microcontroller to activate more features of the watch. To save power, the watch should be in rest mode. Rest mode will reduce the number of samples measured from the sensors, reduce processing. This will save power because, the sensors and communication use a majority of the watch's power.

The main purpose of the skin temperature is to feed temperature measurements of the user to the microcontroller. From the microcontroller, the data can be manipulated into a format that is understandable to the user. In order for the user to get this information and for the design process to be simplified, an analog to digital converter was required.

The accelerometer and temperature sensor will be attached to the regulator as a power source. The regulator can operate off of the 3.3V that the voltage regulator provides. The output pins will be hooked up to the microcontroller. The LIS3DH chosen has a built-in

ADC that converts the analog movement and temperature measurements into digital that can be sent via serial communication. Using this data, the microcontroller can detect whether the user is moving, how much the user is moving, what type of movement the user is doing, and be able to read the temperature. The movement data can also tell the user how many steps that they have taken.



**Figure 52: Accelerometer and Temperature Sensor Schematic**

Figure 52 shows the schematic of the accelerometer and temperature sensor interfacing with the microcontroller. The voltage regulator also contains a temperature sensor. Only 4 of the pins on the accelerometer need to be connected, because the device has a very simple SPI (serial peripheral interface) communication protocol. The data pin (SDA/SDI) gets connected to the microcontroller’s SDA pin, and the clock of the microcontroller is connected to the accelerometer clock pin to synchronize the two devices.

### 5.4.1 Accelerometer GPIO PIN Description

#### Power Pins

- Vin - this is the power pin. Since the chip uses 3 VDC, we have included a voltage regulator on board that will take 3-5VDC and safely convert it down. To power the board, give it the same power as the logic level of your microcontroller - e.g. for a 5V micro like Arduino, use 5V
- 3Vo - this is the 3.3V output from the voltage regulator, you can grab up to 100mA from this if you like
- GND - common ground for power and logic

#### I2C Pins

- SCL - I2C clock pin, connect to your microcontroller's I2C clock line. Has a 10K pull-up already on it.

- SDA - I2C data pin, connect to your microcontroller's I2C data line. Has a 10K pull-up already on it.
- To use I2C, keep the CS pin either disconnected or tied to a high (3-5V) logic level.
- SDO - When in I2C mode, this pin can be used for address selection. When connected to GND or left open, the address is 0x18 - it can also be connected to 3.3V to set the address to 0x19

**Table 25: Accelerometer GPIO Pin Mappings to Raspberry Pi**

Accelerometer	Raspberry Pi 3 Pin name
VCC	Pin 1
GND	Pin 6
SCL/SPC	Pin 5
SDA/SDI	Pin 3
VDDIO	Not used
RES	Not used
CS/MODE	Not used
INT1	Not used
INT2	Not used
ADC1	Not used
ADC2	Not used
ADC3	Not used

### SPI Pins

All pins going into the breakout have level shifting circuitry to make them 3-5V logic level safe. Use whatever logic level is on Vin!

- SCL - this is the SPI Clock pin, it's an input to the chip
- SDA - this is the Serial Data In / Master Out Slave In pin, for data sent from your processor to the LIS3DH
- SDO - this is the Serial Data Out / Master In Slave Out pin, for data sent from the LIS3DH to your processor. It's 3.3V logic level out
- CS - this is the Chip Select pin, drop it low to start an SPI transaction. It's an input to the chip

## 5.5 Bluetooth Communication Design

The purpose of the Bluetooth communication is to make it possible to send data from smart watch to the user's smart phone. To minimize the amount of memory that the smartwatch has onboard, the smartphone will have an app that can store the user's data, creating a profile. To do this, Bluetooth must be implemented to transmit and receive data.

The output of the microcontroller will be attached to the I/O pins of the Bluetooth module to send data to the phone. No data will be sent from the phone to the Bluetooth module, thus we will not need to consider this aspect.

The Bluetooth will take 3.3V, thus it will be paralleled with the rest of the components that are on the low side of the voltage regulator. On a side note, this Bluetooth module offers more features than just Bluetooth capability. It also can be configured to obtain pulse, which will be explored further in testing.

### 5.5.1 Bluetooth GPIO PIN Descriptions

The image below shows the pin layout from the Bluetooth device to the microcontroller. The pin layouts for the device are described below.

#### Power Pins

- **VIN:** This is the power supply for the module, supply with 3.3-16V power supply input. This will be regulated down to 3.3V to run the chip.
- **GND:** The common/GND pin for power and logic.

#### UART Pins

- **TXO** - This is the UART Transmit pin out of the breakout (Bluefruit LE --> MCU), it's at 3.3V logic level.
- **RXI** - This is the UART Receive pin into the breakout (MCU --> Bluefruit LE). This has a logic level shifter on it, you can use 3-5V logic.
- **CTS** - Clear to Send hardware flow control pin into the breakout (MCU --> Bluefruit LE). Use this pin to tell the Bluefruit that it can send data back to the microcontroller over the TXO pin. **This pin is pulled high by default and must be set to ground in order to enable data transfer out! If you do not need hardware flow control, tie this pin to ground** it is a level shifted pin, you can use 3-5V logic.
- **RTS** - Read to Send flow control pin out of the module (Bluefruit LE --> MCU). This pin will be low when it's fine to send data to the Bluefruit. In general, at 9600 bauds we haven't seen a need for this pin, but you can watch it for full flow control! This pin is 3.3V out.

#### Other Pins

- **MOD:** Mode Selection. The Bluefruit has two modes, Command and Data. You can keep this pin disconnected, and use the slide switch to select the mode. Or, you

can control the mode by setting this pin voltage, it will override the switch setting! High = Command Mode, Low = UART/DATA mode. This pin is level shifted, you can use 3-5V logic.

- **DFU:** Setting this pin low when you power the device up will force the Bluefruit LE module to enter a special firmware update mode to update the firmware over the air. Once the device is powered up, this pin can also be used to perform a factory reset. Wire the pin to GND for >5s until the two LEDs start to blink, then release the pin (set it to 5V or logic high) and a factory reset will be performed.

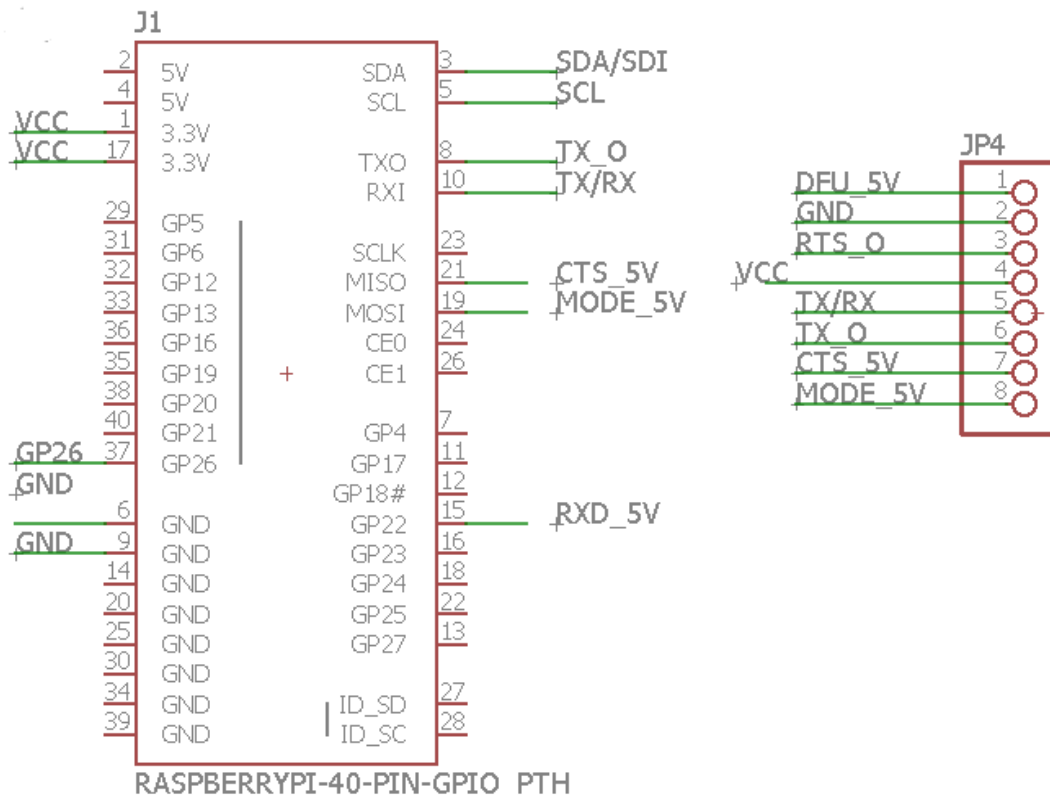
Table 26 explains the exact pin names attached to the Raspberry Pi microcontroller.

**Table 26: Bluetooth GPIO mapping to Raspberry PI**

Bluetooth(JP4) Pin name	Raspberry Pi 3 Pin name
DFU_5V	Not used
GND	PIN 9
RTS_O	Not used
VCC	Pin 1
TX/RX	Pin 10
TX_O	Pin 8
CTS_5V	Pin 21
MODE_5V	Pin 19

### 5.5.2 BlueFruit LE Hardware Technical Specification

- ARM Cortex M0 core running at 16MHz
- 256KB flash memory
- 32KB SRAM
- Peak current draw
- Transport: UART @ 9600 baud with HW flow control (CTS+RTS required!)
- 5V-safe inputs
- On-board 3.3V voltage regulation
- Bootloader with support for safe OTA firmware updates
- Easy AT command set to get up and running quickly



**Figure 53: Bluetooth and Microcontroller Schematic**

## 5.6 GPS Design

The main purpose of the GPS system is to help the authorities pinpoint the exact location of a user who is in distress. Once a user presses the alert button, signals will be sent from the microcontroller to the GPS system which, with the aid of the wireless communication and localized satellites, will get accurate coordinates of a user's location, and send it to the correct point of contact.

A simple test that can be done, includes interfacing the GPS system to a microprocessor correctly and ensuring that module can work indoors and outdoors with a specified accuracy that will meet the smartwatch's requirements.

### 5.6.1 GPS GPIO PIN Descriptions

The image below shows the pin layout from the Bluetooth device to the microcontroller. The pin layouts for the device are described below.

#### Power Pins:

- **VIN:** This is the power supply for the module, supply with 3.3V
- **GND:** The common/GND pin for power and logic.



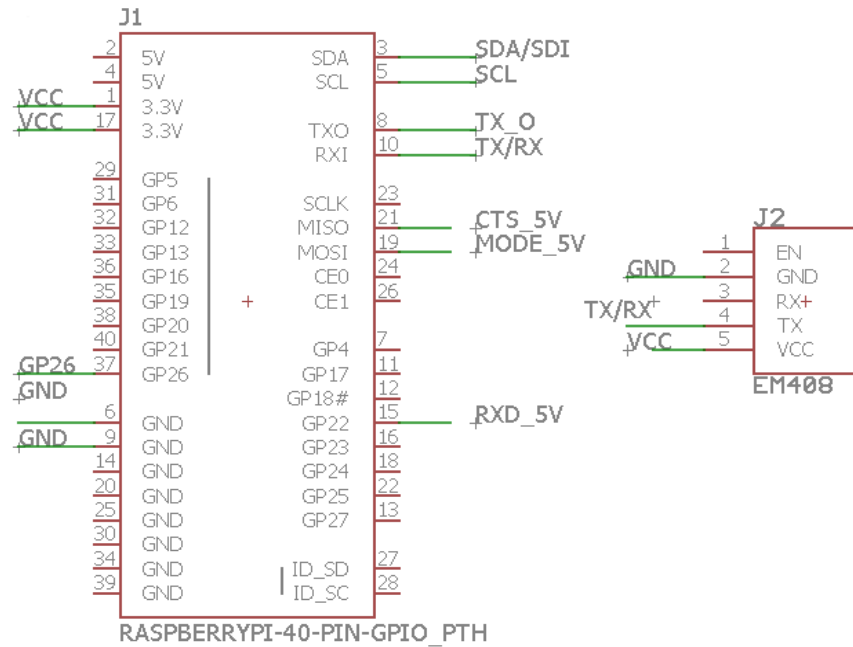
**UART Pins:**

- **RXI** - This is the UART Receive pin

Table 27 explains the exact pin names attached to the microcontroller.

**Table 27: GPS Raspberry Pi 3 GPIO Mapping**

GPS (J1) Pin name	Raspberry Pi 3 Pin name
EN	Not used
GND	Pin 6
RX	Not used
TX	Pin 10
VCC	Pin 1

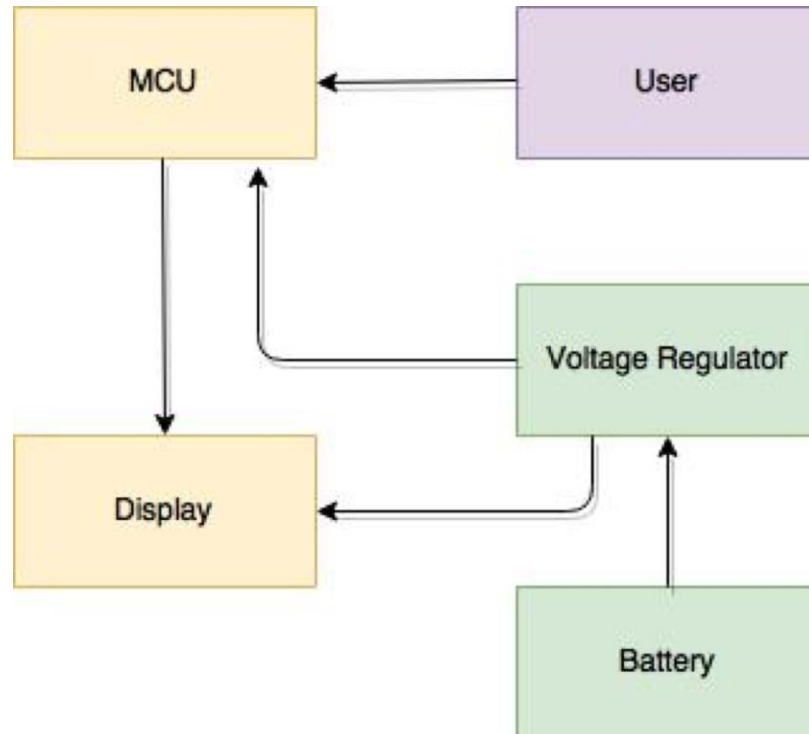


**Figure 54: GPS and Microcontroller Schematic**

**5.6.2 GPS Hardware Technical Specification**

- 56-Channel Receiver (22 Channel All-in-View)
- Sensitivity: -162dBm
- 2.5m Positional Accuracy
- Cold Start: 29s (Open Sky)
- 40mA @ 3.3V
- 3-pin JST Terminated Cable
- 

## 5.7 OLED Display Design Schematic



**Figure 55: Display Design**

The main purpose of the screen is to allow the user to easily read and see information that the Bioelectric Smartwatch will provide. The screen that was chosen, the OLED graphic display is the size of a typical digital screen. The screen itself is 23mm by 35mm. It was chosen because as was mentioned earlier, no backlight is required and this reduces power that would have been used if a backlight was needed.

The microcontroller will perform the switching and functioning between the components of the device. The microcontroller will also be able to display all the data and information to the user. The display is what the user will interact with the most when it comes to the functionality of the Bioelectric Smartwatch. User inputs via sensors as well as switches will allow the user to interact with the device. The inputs from the user are communicated to the device via the microcontroller. Thus, displaying whatever information that we select

to be visible via the display to the user. An outline of the process is illustrated in Figure 55.

In order to test just the screen, header pads that came with the screen will be soldered on the back of the screen. Header pads are electrical connectors that make testing and implementing components easier. In addition, two jumpers will need to be soldered to the back of the OLED.

### 5.7.1 OLED Display GPIO PIN Descriptions

The image below shows the pin layout from the Bluetooth device to the microcontroller. The pin layouts for the device are described below.

#### Power Pins

- **VIN:** This is the power supply for the module, supply with 3.3V.
- **GND:** The common/GND pin for power and logic.

#### UART Pins

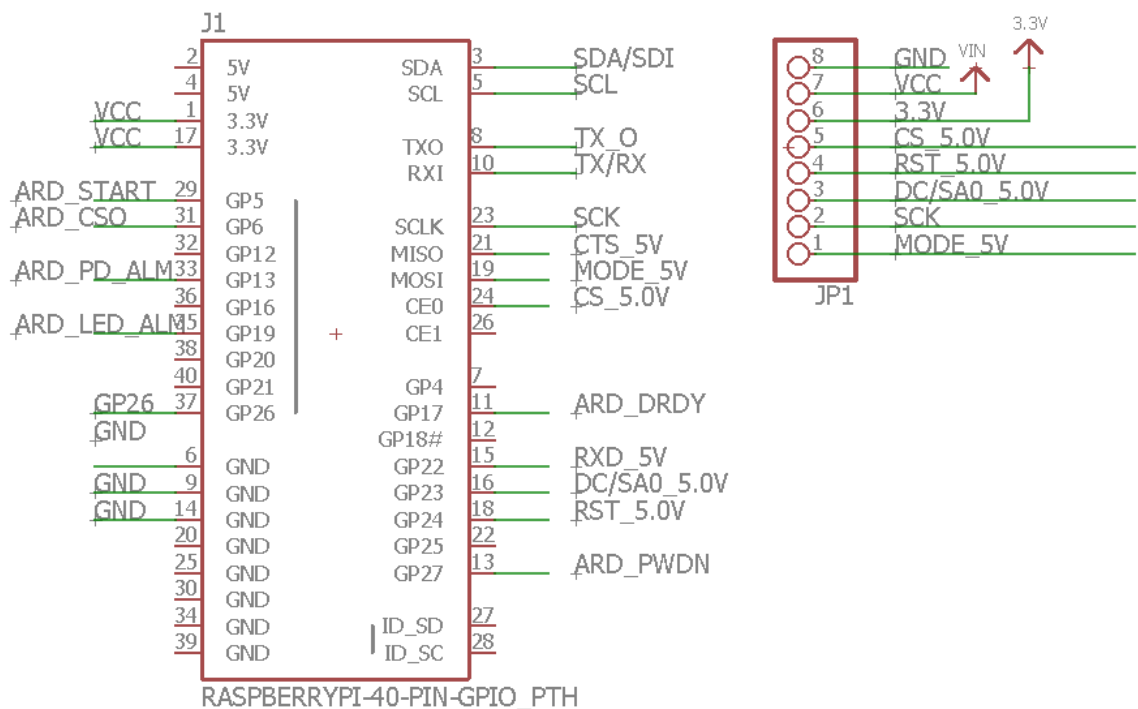
- **CS** - Clear to Send hardware flow control pin into the breakout (MCU --> Display). Use this pin to tell the Bluefruit that it can send data back to the microcontroller over the TXO pin. This pin is pulled high by default and must be set to ground in order to enable data transfer out! If you do not need hardware flow control, tie this pin to ground it is a level shifted pin, you can use 3-5V logic.
- **RTS** - Read to Send flow control pin out of the module (Display --> MCU). This pin will be low when it's fine to send data to the Bluefruit. In general, at 9600 baud we haven't seen a need for this pin, but you can watch it for full flow control! This pin is 3.3V out.

#### Other Pins

- **CLK:** Clock connects to the System Clock.
- **DC:** Display connects General GPIO Pin.
- **RST:** Reset connects to Rest GPIO Pin.
- **Data/MOD:** Mode Selection. The Screen has two modes, Command and Data. You can keep this pin disconnected, and use the slide switch to select the mode. Or, you can control the mode by setting this pin voltage, it will override the switch setting! High = Command Mode, Low = UART/DATA mode.

**Table 28: Display Raspberry Pi 3 GPIO Mapping**

OLED (JP1) Pin name	Raspberry Pi 3 Pin name
GND	Pin 14
VCC	Pin 17
3.3V	Not Used
CS_5.0V	Pin 24
RST_5.0V	Pin 18
DC/SA0_5.0V	Pin 16
D0/SCLK/SCK_5.0V	Pin 23
MODE_5V	Pin 19



**Figure 56: OLED and Microcontroller**

### 5.7.2 OLED Display Hardware Technical Specification

- PCB: 38mm x 29mm (1.5" x 1")
- Screen: 25mm x 14mm

- Thickness: 4mm
- Weight: 8.5g
- Display current draw is completely dependent on your usage: each OLED LED draws current when on so the more pixels you have lit, the more current is used. They tend to draw ~20mA or so in practice but for precise numbers you must measure the current in your usage circuit.
- This board/chip uses I2C 7-bit address between 0x3C-0x3D, selectable with jumpers

## 5.8 Switch Design

In order to alternate between what is displayed on the smartwatch's screen, tactile switches were purchased to make for easy transitioning. Each switch placed on the smartwatch will have its own functionality. One switch is designated to enable the smartwatch's alert system. Once pressed, this button will notify the microcontroller to obtain the user's location using the wireless communication. Once the location has been found, a message will be sent to local authorities, notifying them that there is an emergency and that assistance is needed. However, the same switch will also have an alarm cancellation in the event that the switch was pressed by mistake. The microcontroller will be able to determine if an emergency is occurring by the number of times the switch is pressed.

Another switch will be to obtain current temperature reading. When this switch is pressed, if the temperature sensor is set to single-shot mode, the microcontroller will be notified of request in temperature. This will resume the ADS1115 power mode and update the temperature per user request. Another switch will be used to request the data on a user's pulse. The microcontroller will send a signal to the AFE4400 to allow for quick measurements on the user's pulse. One switch is designated on the accelerometer measurements. Because the accelerometer will be used to determine whether the user is active or in a resting position. As a result, once the switch has been pressed, the LIS3DH accelerometer will be in a rest mode until a certain frequency has been met. At the specified range, the LIS3DH will be placed in active mode and record the movement and be able to tell the user the amount of steps taken. A diagram of the initial design of the switches connected to its respective sensor/ features through the microcontroller can be seen below in Figure 57.

A simple test that will be conducted to check that the switches are a simple circuit check. An LED is required for this test. A DC voltage supply from will power the circuit. A 50 Ohm resistor and a red LED will be placed in series with this power supply closing the circuit. Ground will also be placed on the circuit. A switch will be inserted in series between the power supply and resistor. A successful test is evident when the red LED can be turned on and off with each press of the switch. A circuit diagram can be seen in Figure57.

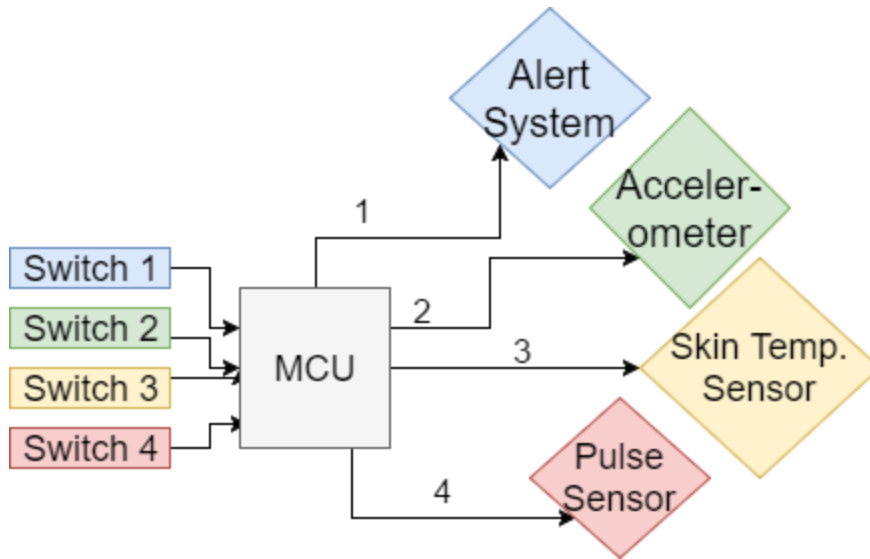


Figure 57: Switch Connection Diagram

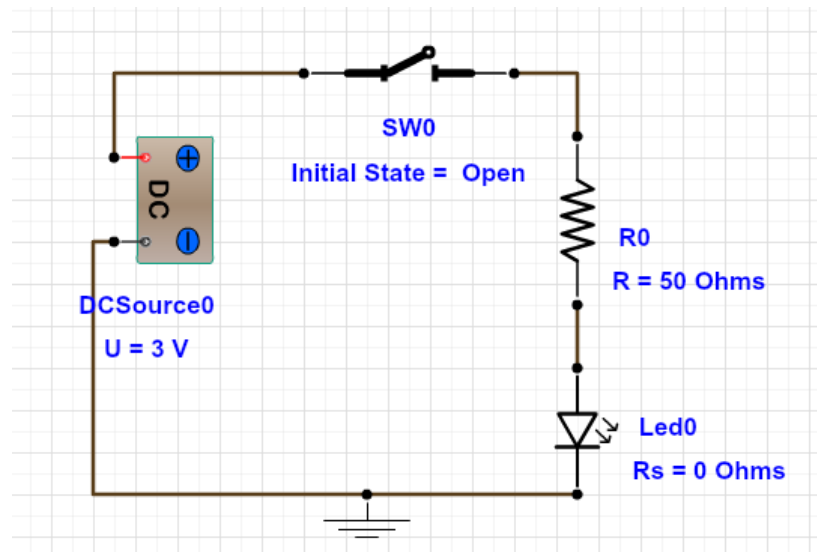


Figure 58: Simple Switch Test Schematic

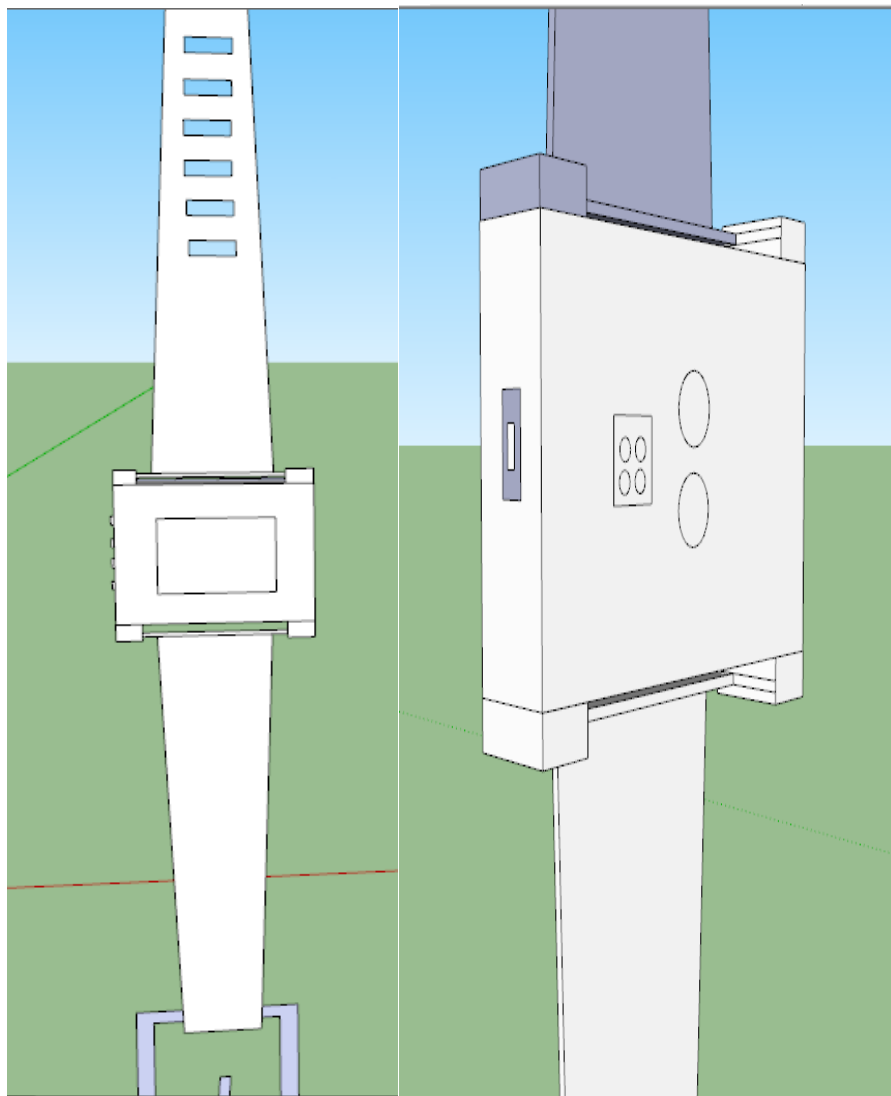
## 5.9 Hardware Design

The hardware design of the watch is an important consideration, because it will greatly influence how the user interfaces with the watch. Currently, the physical design of the watch is in a prototyping phase until the electrical design can be tested and in working order.

### 5.9.1 General Layout

The general layout of the watch will be as such: A single case will contain all of the components of the watch. The case will be either made of molded plastic, or 3D printed, because the shape of the watch may very well need to be custom. The OLED screen will

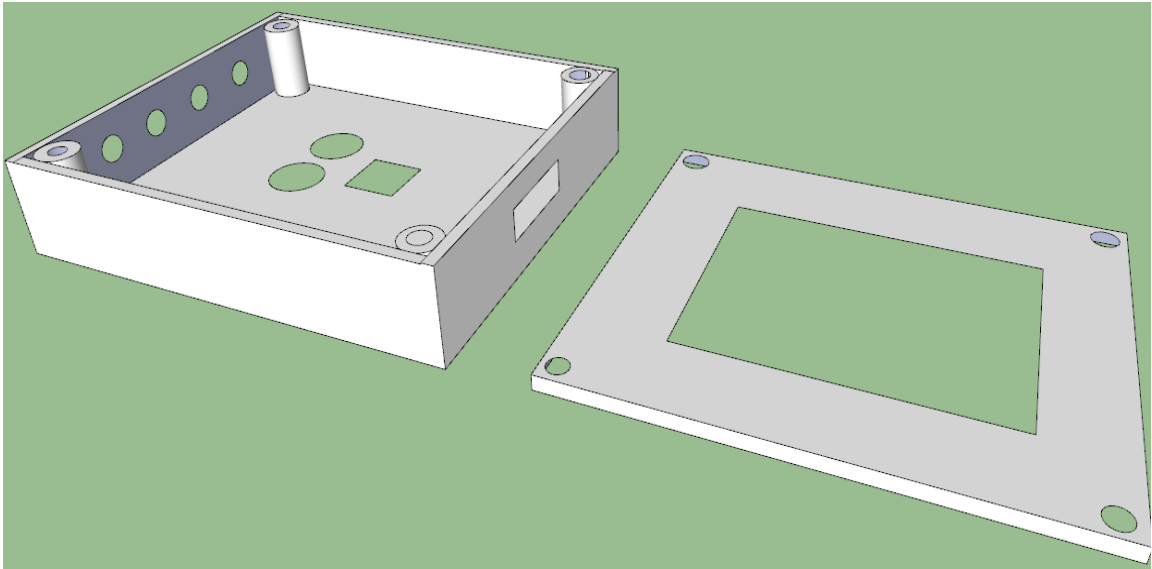
be on the face of the watch so that the user can easily see the watch. The push buttons will be mounted to the side of the watch so that they are not in the way of the screen. The USB port for charging the watch will be placed on the opposite side of the push buttons so that the user may push the buttons while the watch is plugged into a USB cable. The watch will accept a mini USB cable. On the back of the watch (side that touches the user's wrist) will contain the sensors. The sensors will be centrally located to help eliminate outside temperature and light from affecting the measurements. The wrist strap will contain several slotted holes to allow for the user to adjust the size to properly fit their wrist. A clasp will be on the end of one side of the wrist band to lock into one of the slotted holes and keep the watch secure to the user's wrist. The back of the watch will either be flat or slightly convex to hug the user's wrist. Testing will need to be conducted to see which yields better results and which is possible from a construction standpoint.



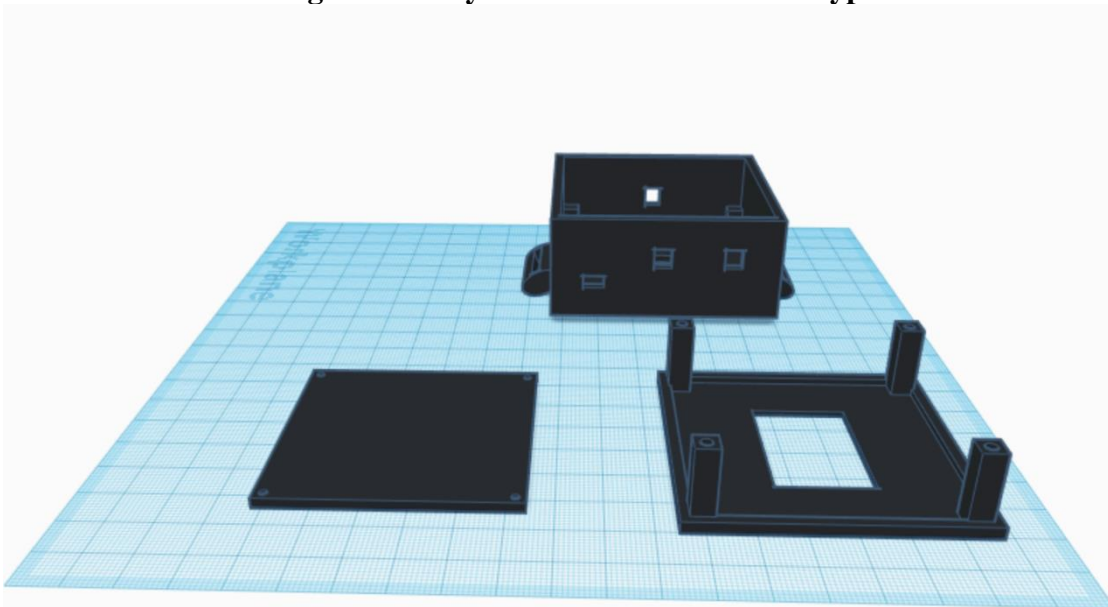
**Figure 59: The general physical layout of the smartwatch prototype. Frontal view (left), back view (right)**

More research is needed to determine the best material for the strap of the Bioelectric Smartwatch. Most plastics that have been researched use a flexible hypoallergenic material in order to minimize skin irritation.

### 5.9.2 Watch Shell



**Figure 60: Layout of Watch Shell Prototype**



**Figure 61: Layout of Watch Shell**

The goal of the shell design is to accommodate all of the components internally, allow functionality of the watch's sensors, enable the user to see the screen easily, be comfortable, and allow the user access to the buttons and USB port. The shell will be square, and can either have rounded or square corners (rounded may be more ergonomic).



4 columns, one in each corner of the shell, will be tapped to house a machine screw. The machine screws will attach the two separate pieces of the shell together. The shell needs to be two separate pieces because access to the inside components will be necessary for assembly and testing. Dimensions of the prototype are currently unknown, because the electrical design has not been constructed, but they will be measured when the final product is assembled. On the face of the shell, a hole will be mortised to attach the OLED screen. The sides of the shell will have holes milled out for the buttons and USB port. The back of the shell will be milled out to allow for the LED, photodiode, and temperature to be mounted in a way that will allow them to touch the user's skin.

### **5.9.3 Watch Shell Change in Senior Design 2**

The layout for the watch shell was adjusted due to changes in Senior Design 2. Figure 61 is the new watch shell case layout. Some major changes were that the power button, screen toggle button, and battery charger were placed on one side of the watch case. The emergency button was placed on the opposite side. The flat black square that can be seen in Figure 61 is for the PCB to rest on inside the casing.

### **5.10 Overall Design**

After completing the system design of the full schematic was created to show all the components that were listed and their connections. To avoid confusion, the wires are named to show their connections instead of directly connected to each other to avoid any improper connections. The Eagle software allows every net with the exact name to be connected. The image below shows the schematic.



### 5.10.1 PCB Schematic

Figure 63 shows the Final PCB layout used for the Bioelectric Smartwatch. The PCB was designed in three different configurations to maximize board size and determine how component placement affected the circuit as a whole. The first PCB that was designed was 3.2 by 2.5 inches. The final PCB was 2.2 by 2.18 inches. Some of the major alterations between the first board and the final board include changing incorrect connections, connecting analog voltage sources, adding additional components and ICSP pins, and making sure to include decoupling capacitors. These changes were necessary in order to get the entire board to work properly. To fabricate this board, the group used PCBway because of the company's timely turnaround.

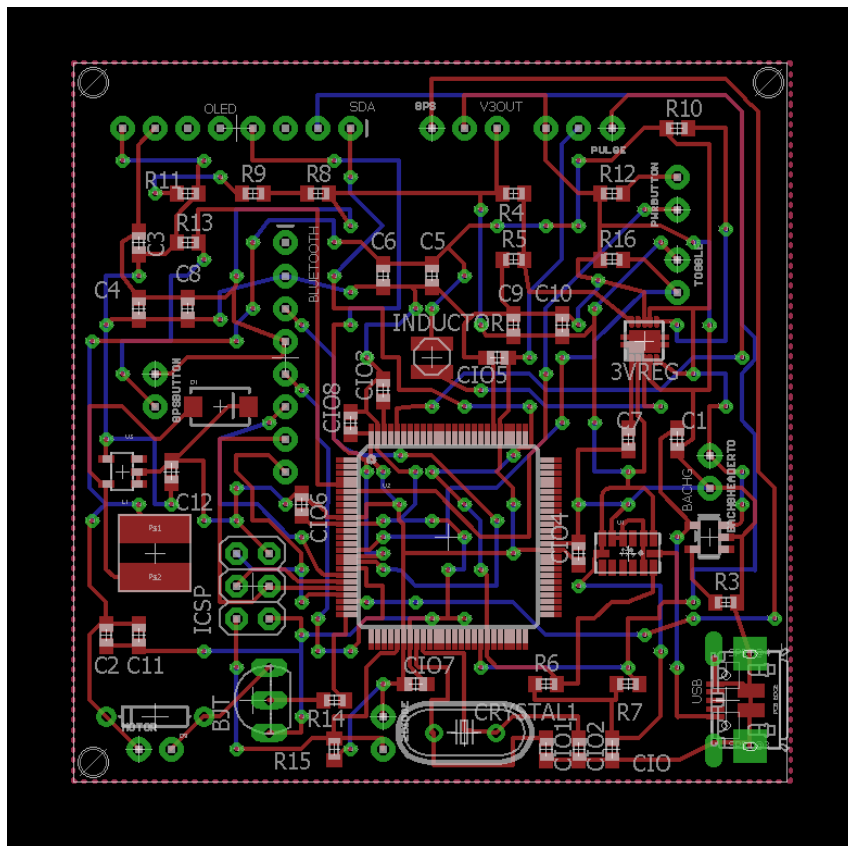


Figure 63: Final PCB Schematic

## 6.0 Software Design

Software application should include integrated systems that show the users daily tasks, notify them accordingly, and safely record the user's performance based on the completion of those tasks. The primary function of our smart watch is to monitor personal attributes of the user for example walking steps, and time elapsed in tasks and tracking like and provide adequate and simple feedback to the user. The design of the software application should be intuitive and user friendly interface for interconnecting user health status which include a smart phone. Smart watch application also includes an network to connect to one portable network device and a server. Our proposed solutions, and one of the few target audience of our product are about to extend the scope of support for elderly people, who want to stay in their familiar home in a safe and self-determined way, as long as this can be justified by medical reasons.

### 6.1 Software Framework Ionic

For the purpose of this project we will be using Ionic an open-source mobile application framework. Ionic is powerful because it cross platform between Android and IOS Mobile devices, well documented and supported with native mobile- plugins. Ionic have capabilities for mobile design prototyping, multiple device testing simulators, and buildable. Ionic is an MIT-licensed, front-end framework for creating hybrid mobile apps. Ionic is also a Node module that helps with the process of creating, building, and packaging hybrid apps. The Ionic framework and module are backed by the same company, Drifty. In the context of this article, Ionic will be used in both cases. Either way, Ionic empowers developers to leverage their AngularJS and HTML5 skills to create beautiful, high-performing apps.

### 6.2 Ionic Framework Setup

Ionic relies on Node.js. For that reason, you must install Node.js if you haven't done so previously. You can get the Node installer from <http://nodejs.org/>. Once installed, Ionic can be installed using Node's package manager (npm) via the following command-line. With your console window, open, enter the following. The preceding command will install the Ionic and Apache Cordova modules globally. The modules themselves are installed in your user directory. If you're running Windows, the modules are at C:\Users\{username}\AppData\Roaming\npm. If you're running Mac OS X or Linux, the modules can be found in /usr/local.

### 6.3 Ionic Framework Running Application Through Browser vs Native Platforms

**Browser:** Ionic apps are built with web technologies. You can develop, debug, and test Ionic apps in the WebKit browser of your choice. Browsers that support WebKit include Apple Safari, Google Chrome, and the Opera browser. To open an Ionic app in one of these browsers, you need to host the app in a web server. Ionic lets you run your apps locally via

LiveReload. LiveReload is a server that gets installed as a Node module. This module was installed when a snippet was run.

You can get pretty far along developing your app in the local browser. However, your app may need to use features that are more readily available on a real device. For example, your app may make use of an accelerometer or a compass. These capabilities are more likely to exist on your phone than the machine you're cranking code on. For that reason, we need to discuss running apps on native platforms.

**Native Platforms:** Running apps built with the Ionic framework on a native platform requires Apache Cordova. Cordova is an open source library that makes device-level APIs accessible to JavaScript. In other words, things like the accelerometer or compass become programmatically accessible through JavaScript. This bridge helps you cross the divide between physical hardware and more malleable software. The Ionic module makes it simple to target platforms when you're ready to start testing and deploying your app on specific platforms. From the command line, you enter `ionic platform add <PLATFORMNAME>` to prepare your app for a specific environment. For example, if you want your app to run on the three most popular mobile platforms (Android, iOS, and Windows Phone).

Building your Ionic app creates a package using the SDKs installed on your local machine. You have the option of using the package task instead. That task uses the Ionic Build service to create app-store ready bundles without using SDKs on your local machine. This is especially useful if you're creating apps on a Linux or Windows machine and want to pump out an iOS app.

There are two other libraries you should be aware of when building your Ionic app. Two libraries that will help you build apps with Ionic are called `ngCordova` and `ngCordovaMocks`. `ngCordova` is a set of extensions that bridge the gap between AngularJS and Cordova. As Ionic makes heavy use of AngularJS, these extensions may become an integral part of your development. `ngCordovaMocks` complements `ngCordova` in that it empowers you to continue developing and testing your app in a web browser. These libraries are optional, but highly recommended.

Once you've created your application packages, you might want to run them. You have several options. The two most popular include running the package in a simulator or on a physical device.

## 6.4 Running Application on the Simulator vs Physical Device

Running your app in a simulator can be more convenient than running it on a physical device. Ionic makes it easy to run your app in a simulator from the command line. Running your app in a simulator will get you closer to the real thing than the previously mentioned browser emulation. However, there's nothing better than the real thing. For that reason, we are considering running (and testing) your app on a real physical device. This task requires the `--device` argument to `ionic deploy` to run the app on a physical device. Once run, this task

builds the project, creates the application package, and deploys the app to a connected physical device. From there, you can continue your testing.

## **6.5 Software Definitions, Acronyms, and Abbreviations**

- **API - Application Programming Interface**
- **HTML - Hypertext Markup Language**, a language used specify the visual layout of websites.
- **JavaScript** - is a computer programming language that is concurrent, class-based, object-oriented for web development.
- **Wi-Fi** - is a local area wireless technology that allows an electronic device to exchange data or connect to the internet using 2.4 GHz UHF and 5 GHz SHF radio waves.
- **GPS - Global Positioning System** is a space-based satellite navigation system that provides location and time information in all weather conditions, anywhere on or near the Earth where there is an unobstructed line of sight to four or more GPS satellites
- **UDP = User Datagram Protocol**

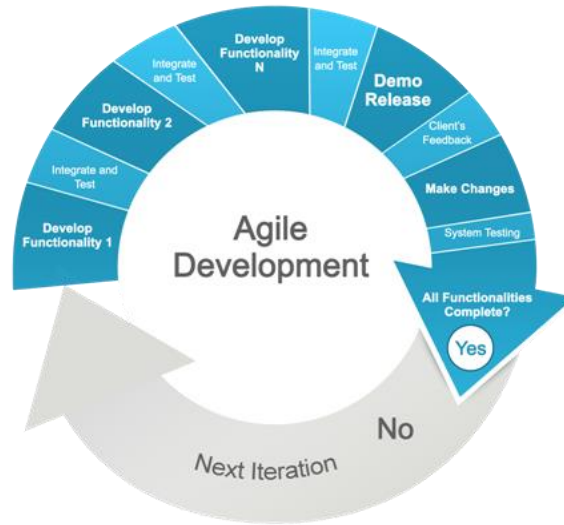
### **6.5.1 Software Life Cycle Process**

Our group will be using an Agile development process. This process is a way to empower the group into working more effectively than our current methods. One of the biggest issues was that each of the members of the group have divergent schedules that make meeting difficult. The self-organizing, cross functional group nature of the Agile process fits well with our time constraints and the multiple roles that each member of the group will be fulfilling. Furthermore, our project has a fair amount of theory/research material in it, which fits well with the evolving product aspect of Agile lifecycles. Using this, the group hopes to implement deadlines adequately.

## **6.6 Software Assumptions**

Some of the assumptions that we will utilize when incorporating can be seen below:

- All devices are smartphones .
- All devices have Wi-Fi
- All devices have GPS.
- 100MBs Memory App usage.
- Memory and processor are irrelevant to the apps functionality.



**Figure 64: Agile Software Development Software**

## 6.7 Storing Application with Version Control Systems

Git is a “version control system,” As our mobile application developers are creating something, they are making constant changes to the code and releasing new versions, up to and after the first official (non-beta) release.

Version control systems keep these revisions straight, and store the modifications in a central repository. This allows developers to easily collaborate, as they can download a new version of the software, make changes, and upload the newest revision. Every developer can see these new changes, download them, and contribute.

Similarly, people who have nothing to do with the development of a project can still download the files and use them. Most Linux users should be familiar with this process, as using Git, Subversion, or some other similar method is common for downloading needed files, especially in preparation for compiling a program from source code (a rather common practice for Linux geeks).

In case you are wondering why Git is the preferred version control system of most developers, it has multiple advantages over the other systems available, including a more efficient way to store file changes and ensuring file integrity.

## 6.8 Common GitHub Features

### Forking a Repo

“Forking” is when you create a new project based off another project that already exists. This is an amazing feature that vastly encourages the further development of programs and other projects. If you find a project on GitHub that you’d like to contribute to, you can fork

the repo, make the changes you'd like, and release the revised project as a new repo. If the original repository that you forked to create your new project gets updated, you can easily add those updates to your current fork.

## **Pull Requests**

You fork a repository, make a great revision to the project, and want it to be recognized by the original developers, maybe even included in the official project/repository. You can do so by creating a pull request, so the authors of the original repository can see your work, and then choose whether to accept it into the official project. Whenever you issue a pull request, GitHub provides a perfect medium for you and the project's maintainer to communicate.

## **Social Networking**

The social networking aspect of GitHub is probably its most powerful feature and is what allows projects to grow more than anything else. Each user on GitHub has their own profile, which can act like a resume of sorts, showing your past work and contributions to other projects via pull requests.

Project revisions are able to be discussed publicly, so a mass of experts can contribute knowledge and collaborate to advance a project forward. Before the advent of GitHub, developers interested in contributing to a project would usually need to find some means of contacting the authors, probably by email, and then have to convince them that their contribution is legit and they can be trusted.

## **Changelogs**

When multiple people are collaborating on a project, it's really hard to keep track of who changed what and to keep track of the revisions that took place. GitHub takes care of this problem by keeping track of all the changes that have been pushed to the repository.

## **6.9 Software Event Table**

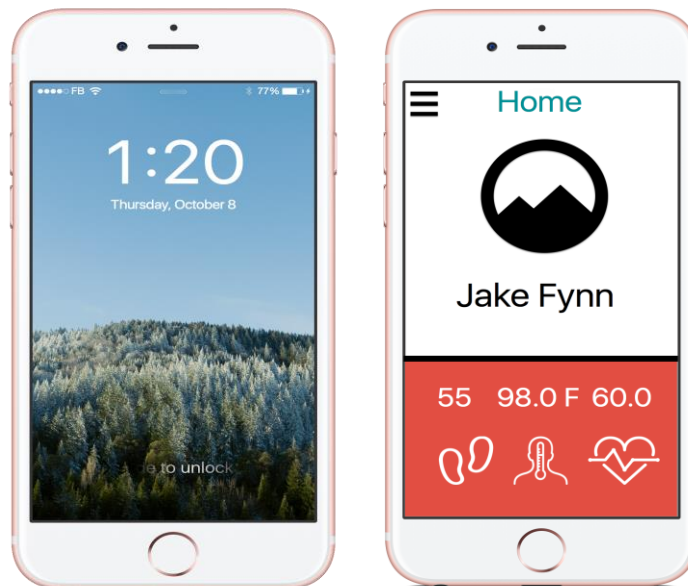
The table shows that the software events for testing of the Bioelectric Smartwatch during the mobile application. This table outlines some of the major cases that we expect the user to access on the Bioelectric Smartwatch as well as the events that take place within the smartwatch's software. Future cases will be done once prototyping is completed to test for an even larger scale of test cases.



**Table 29: Software Events for Testing**

Event Name	External Stimuli	External Responses	Internal data and state
Activate	User Initiated	Activates the Smart watch and user's location is tagged on Map.	Sends signal to mobile application once they have logged in the phone.
Send Message	Watch Initiated	Sends message to the	Sends message to nearby users
Sensor Activation	User Initiated	Bluetooth to the mobile app which will collect data every 1-2 minutes	Resends if failed
Emergency Services Alert	User Initiated	Alert is sent out to all users nearby	Alert is sent to all users nearby

## 6.10 Software User Interface Mobile



**Figure 65: Mobile App Prototype Layout**

## 6.11 Software Testing Mobile

If errors are determined during testing, these bugs will be noted in the developer's weekly activity log. If the developer is assigned to the component that failed, the developer may fix the component immediately. Otherwise, the developer should inform, in a timely manner, the developer(s) responsible for the component of the test conditions and test results.

When testing functionality of a module test cases are written before the code itself; at that point, they are impassable. Code is written specifically to pass a given test case. When the written code successfully passes the test, the passing code is refactored into a more elegant module – without introducing any new functional elements.

By using this test-driven development strategy, we can improve our iterative build process in the following:

- It facilitates easy maintenance and helps alleviate scope creep
- Encourages granularity in testing; it is guaranteed that every standalone piece of logic can be tested
- since test cases are written first, other programmers can view the tests as usage examples of how the code is intended to work

At the end of the lifecycle, all test cases will be run against the total code base to verify the functionality of the app. Communication errors will take priority over any cosmetic errors, these are more defined test cases, and the final project depends on full functionality of communication.

If errors are determined during testing, these bugs will be noted in the developer's weekly activity log GitHub. If the developer is assigned to the component that failed, the developer may fix the component immediately. Otherwise, the developer should inform, in a timely manner, the developer(s) responsible for the component of the test conditions and test results.

When the testing functionality of a module test cases is written before the code itself; at that point, they are impassable. The code is written specifically to pass a given test case. When the written code successfully passes the test, the passing code is refactored into a more elegant module – without introducing any new functional elements.

By using this test-driven development strategy, we can improve our iterative build process in the following:

- it facilitates easy maintenance and helps alleviate scope creep
- encourages granularity in testing; it is guaranteed that every standalone piece of logic can be tested
- since test cases are written first, other programmers can view the tests as usage examples of how the code is intended to work

At the end of the lifecycle of the project, all test cases will be run against the total code base to verify the functionality of the app. Communication errors will take priority over any cosmetic errors, these are more defined test cases, and the final project depends on the full functionality of communication. The Software should complete all the test cases for each module to ensure no functionality was lost by changes.

## 6.12 Software Individual Test Cases Mobile

Listed below are a few of the test cases obtained via the mobile application for the Bioelectric Smartwatch.

### 1. **Test Objective:** Connectivity

#### **Test Description:**

1. Open the application on the smartphone
2. Log in to software
3. Engage “Send” command

#### **Test Conditions:**

1. User has no wireless internet connection
2. User has no cellular service
3. User has ideal connectivity (GSM, GPS, Wi-Fi, all options)

**Expected Results:** Other test candidate (mobile device) should receive a push notification.

### 2. **Test Objective:** Test Sensor Feature

#### **Test Description:**

1. Open the application on the smartphone
2. Log in to software
3. Engage sensors to read data

**Expected Results:** There should Data should be sent via Bluetooth

### 3. **Test Objective:** User Location

#### **Test Description:**

1. The event will be activated
2. Obtain the GPS coordinates of the user

**Expected Results:** There should be a location geotagged on the map.

### 4. **Test Objective:** Messaging

#### **Test Description:**

1. Open the application on the smartphone
2. Create the message
3. Transmit the message
4. Additional user receives transmitted message

**Expected Results:** The additional user will receive the message transmitted to the additional user.

**5. Test Objective:** Emergency Services Alert

**Test Description:**

1. Open the application on the smartphone
2. Create the health alert
3. Transmit the Health Alert
4. Additional users receive transmitted health alert

**Expected Results:** All users will receive the health alert that was transmitted.

## 6.13 Software Security

The increasing usage of wearable technologies and cloud services in applications, such as health care, could result in new attack vectors for the ‘Cloud of Things’, which could in turn be exploited to release of sensitive user data. One of the next key areas of expansion for wearable devices will be integration with cloud computing with storage and data communication. This amalgamation will provide wearable devices with access to a range of confidential user information, which will greatly improve their utility when undertaking day-to-day tasks for example, a smartwatch having real-time access to the user’s calendar service. However, with this increase in functionality comes a risk to user privacy, where wearable devices have not been appropriately secured.

Security may not be a major consideration for wearable device manufacturers, as the last generation of devices generally lacked direct access to online services. In the majority of cases to date, privacy issues with smart wearable technologies have been a result of their recording capabilities and the privacy impact on those in the surrounding environment of the device’s user.

Generally, fitness trackers are often in market cheaper and are also widely available but generally have less potential to store sensitive user information. While smartwatches are becoming increasingly prevalent, relatively little in-depth studies has been conducted into the types of data which they store and if this data is sufficiently protected to prevent a breach of the user’s privacy, particularly in a health care settings.

The most common privacy concern is enabling companies, manufactures and other organizations to track them across the Internet and learn their interests and behaviors. Since the common communication pair is via Bluetooth. Bluetooth is known to be particularly insecure as mentioned before, with many vulnerabilities that could be exploited by malicious attackers.

Today smartwatches tend to store only a portion of the sensitive data stored on a smartphone. This is because of their reduced functionality and reliance on paired

smartphones. New and upcoming smartwatches, such as the Apple Watch, have a far greater number of functions and features, including near-field communication. As the number of features in a smartwatch increases (and their reliance on a paired device decreases), the prediction is that the amount of sensitive information stored on these devices will also rise.

To enhance security, we are proposing on the encrypting the smart device to enhance security and prevent attacking. This proposal will be especially possible if we could find good research materials and journal articles on this topic. The leading smartwatch manufacturers continue to increase security features on mobile devices to prevent the exfiltration of sensitive user data. We hope to that we can build trust with our smartwatch users.

**Table 30: Data Extraction Comparison Methods for Smartwatch Devices**

USB connection	Using the USB connection of the wearable device as an exfiltration medium means that the attacker must either infect the device to which the wearable device is connected or have physical access to the device.
Bluetooth	Bluetooth has a reasonably short transmission range for data exfiltration. It is also a common area of security research (refer to preceding texts), meaning the newest implementations may be very secure.
SMS	Several wearable devices can send voice dictated messages and quick replies. This could be utilized by an attacker to covertly exfiltrate data. Shortcomings of this medium are that it is limited by the user’s mobile plan and the fact that some operating systems limit the number of messages that can be sent within a time period.
NFC	The newest wearable devices have the ability to communicate via NFC. This could allow an attacker with close proximity to the wearable device to exfiltrate data.
Wi-Fi and mobile network	Newer wearable devices have the ability to directly connect to a mobile or Wi-Fi network, providing this powerful medium to malicious attackers.

## 6.14 Senior Design 2 Software Update

Android Development with Android Studio is the official Integrated Development Environment (IDE) for Android app development, based on IntelliJ IDEA. On top of IntelliJ’s powerful code editor and developer tools, Android Studio offers even more features that enhance your productivity when building Android apps, such as fast emulators and custom designs.

## 7.0 System Testing

The system testing section is designed to describe the methods of component and system integration testing on the breadboard and simulations. This section includes tests done in the software and hardware aspects of the Bioelectric Smartwatch.

### Raspberry Pi 3 Component for Testing:

Raspberry Pi 3 microcontroller was used to test the display, GPS, and Bluetooth components. The Raspberry Pi is open hardware, with the exception of the primary chip on the Raspberry Pi, the Broadcom SoC (System on a Chip), which runs many of the main components of the board—CPU, graphics, memory, the USB controller, etc. The Raspberry Pi was designed for the Linux operating system, and many Linux distributions now have a version optimized for the Raspberry Pi. The image below shows the Raspberry Pi 3 Microcontroller and the GPIO PIN Layout which will be discussed in section 5.

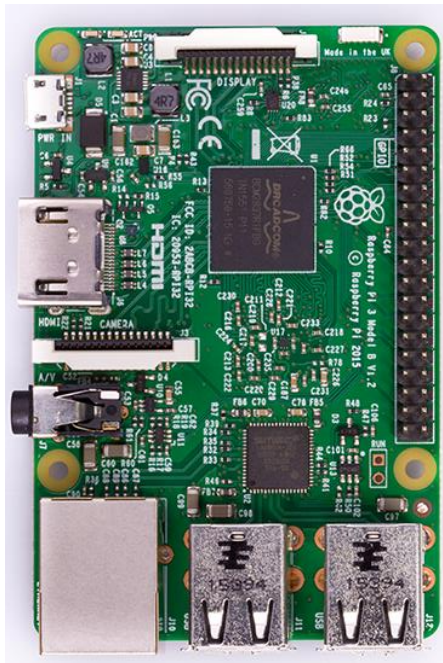
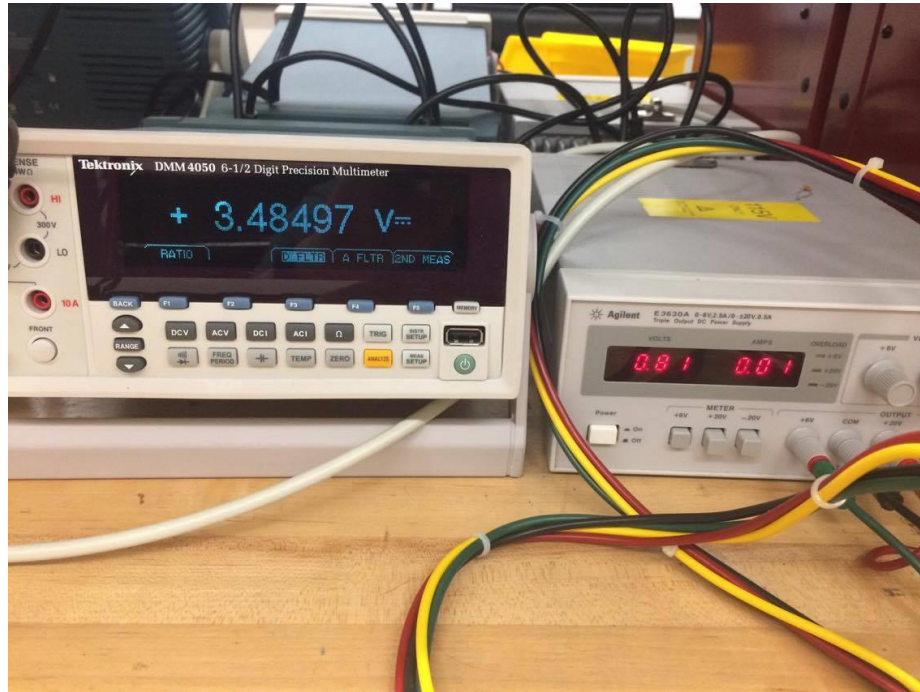


Figure 66: Raspberry Pi 3 Microcontroller

### 7.1 Motor Testing

The design to control the motor was then tested. A PN2222A bipolar transistor (BJT) was implemented into the circuit to throttle the motor, and a 1N4148 is used to eliminate the spike from quickly eliminating the supply current to the motor. The BJT is used to reduce the amount of current that the microcontroller must supply to the motor to activate it. The microcontroller can use minimal voltage to activate the motor by being connected to the base of the BJT. During the testing, the BJT allowed current flow from the collector to the emitter at approximately 0.7V at the base, and allowed maximum flow at a base voltage of 0.8V. The voltage that the microcontroller will be set to output will be 0.8V to allow for the full supply voltage to pass across the vibrating motor. The results can be seen in Figure

67 on the Tektronix DMM4050 Digital Multimeter. The power supply voltage was set to 3.7V, but the results show that a voltage drop occurs, giving the vibrating motor an actual voltage of 3.4V. This voltage is sufficient to notify the user. The base voltage was also increased over 0.8V, but that did not further increase the voltage across the motor.

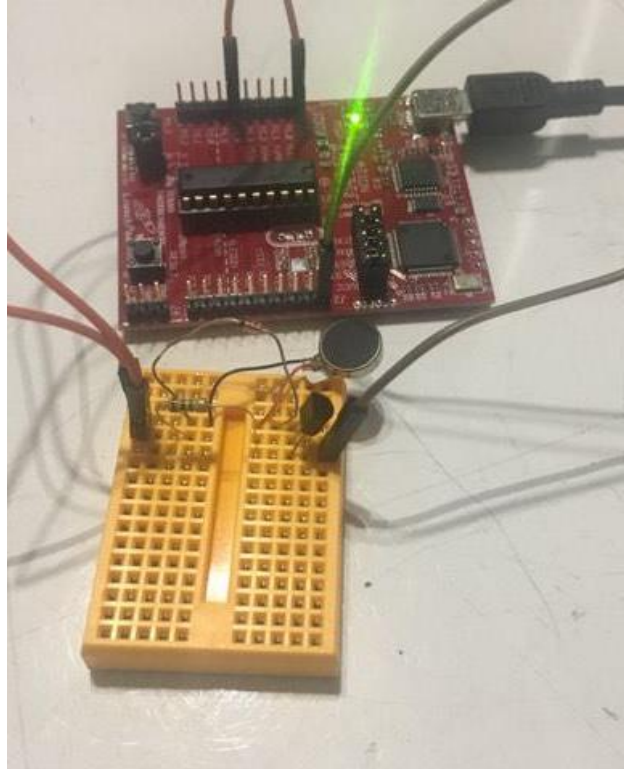


**Figure 67: Supply voltage and base voltage of vibrating motor circuit**

To test the microcontroller being attached to the motor, a resistance of  $5k\Omega$  was implemented to connect the microcontroller to the base of the BJT. A simple voltage divider formula, paired with the BJT formulas were used to solve for this resistance. The microcontroller output 3.5V to the BJT base, and the BJT base was at 0.8V. The goal of putting 0.8V to the base was accomplished. While the microcontroller was connected, a voltage of 3V was observed across the motor. The motor was running, and the current across the motor matched what was listed in the datasheet.

## 7.2 Power Testing

The power system testing will include the voltage regulator, battery, and battery charger testing. The battery and regulator were also hooked up to components to test the power circuit.



**Figure 68: Motor Breadboard Testing**

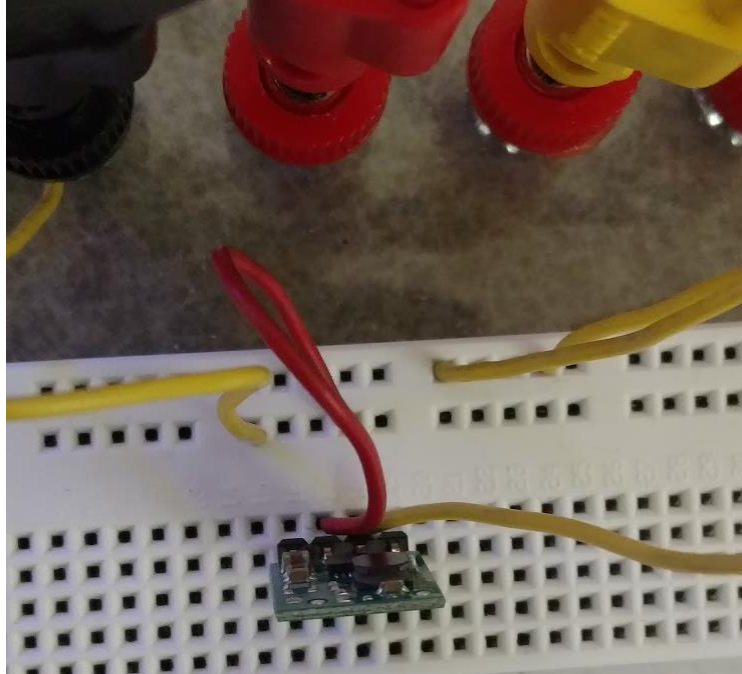
### **7.2.1 Battery and Battery Charger Testing**

The testing process for the battery was to simply check the voltage of the battery out of the box, and then to check the voltage of the battery while it is charging. The battery is a 3.7V nominal, but measures 3.92V out of the box. A Craftsman digital multimeter was used to measure the voltage while charging, and not charging. The maximum charging voltage from the charger was 4.2V.

### **7.2.2 Voltage Regulator Testing**

A simple test on the voltage regulator was done to ensure that it was working as specified in the datasheet. The pin labeled SHDN was not used. The pin labeled VIN was attached to a DC voltage power supply that was initially set to 1 volt, the pin labeled GND was set to ground. The last pin labeled VOUT was used to determine the correct output. In Table 31, the test can be seen below. A digital multimeter was used to measure the input and output voltages by connecting the positive terminals. From this test, it can be seen that the output of the voltage regulator remained constant as the input voltage increased. Figure 69 shows the test set-up of the voltage regulator where the red wire is connected to the power supply and the yellow wire is connected to ground.





**Figure 69: Image of Voltage Regulator attached to Power Supply**

**Table 31: Voltage Regulator Preliminary Test**

Voltage Supply	Input Voltage	Output Voltage
1.02	1.02048	3.32781
2	2.04	3.32832
3	2.96	3.32714
4	4.01	3.33810

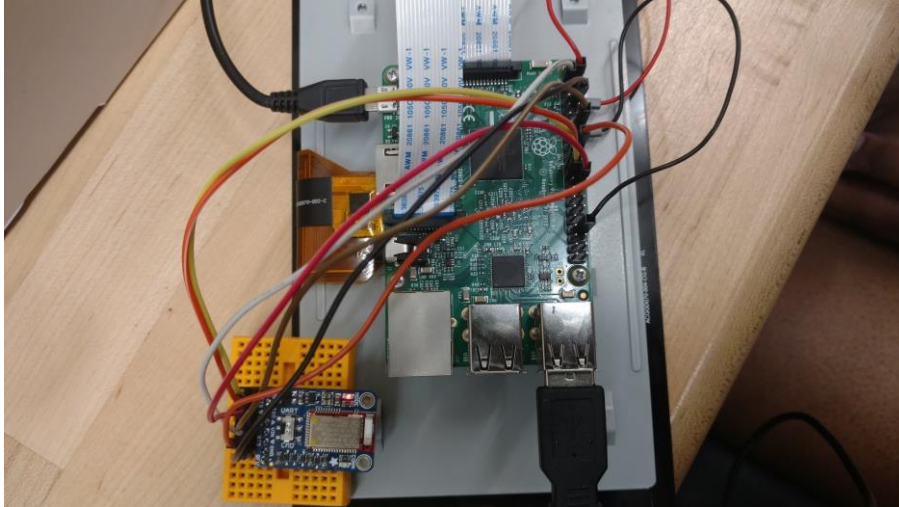
## 7.3 Bluetooth Testing

The Bluefruit LE UART Friend makes it easy to add Bluetooth Low Energy connectivity to anything with a hardware or software serial port. The Nordic UART RX/TX connection profile. In this profile, the Bluefruit acts as a data pipe, that can 'transparently' transmit back and forth from your iOS or Android device.

### 7.3.1 BlueFruit LE UART Device Read and Write Data Test

**Test Objective:** Connect to Bluetooth with Raspberry Pi and confirm the Bluetooth reads and writes data.

**Result:** The BlueFruit LE is discoverable and able to read and write data.



**Figure 70: BlueFruit LE UART Wiring for Raspberry Pi**

### **Bluetooth Software Installation:**

To install BlueZ 5.33 on a Raspberry Pi first make sure it's running the latest Raspbian operating system and is connected to the internet with a wired or wireless network connection. Then to make sure the Bluetooth daemon runs at boot and is run with the --experimental flag to enable all the BLE APIs. To do this edit the /etc/rc.local file with a text editor.

Once you confirm BlueZ is running with the experimental flag you can move to the library install section below. There's one final step to prepare to use the library on a Linux machine or Raspberry Pi. Then need to install the python-dbus library to ensure it's available for the library to use. That's it, the library should be installed globally and ready to use with any Python script on your system.

```
sudo python uart_service.py

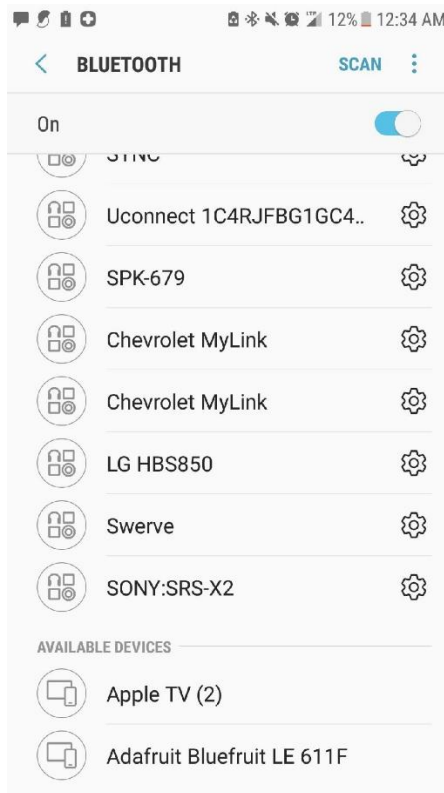
Using adapter: BlueZ 5.33
Disconnecting any connected UART devices...
Searching for UART device...
Connecting to device...
Discovering services...
Sent 'Hello world!' to the device.
Waiting up to 60 seconds to receive data from the device...

H [0x48] e [0x65] l [0x6C] l [0x6C] o [0x6F] [0x20] w [0x77] o [0x6F] r [0x72] l [0x6C] d [0x64] ! [0x21] [0x00]
[0x0A]
Received: test
```

**Figure 71: Bluetooth outputting “Hello World” to the terminal**

Once you confirm BlueZ is running with the experimental flag you can move to the library install section below. There's one final step to prepare to use the library on a Linux machine or Raspberry Pi. Then need to install the python-dbus library to ensure it's available for

the library to use. That's it, the library should be installed globally and ready to use with any Python script on your system.



**Figure 72: Bluetooth Discoverable to Mobile Device**

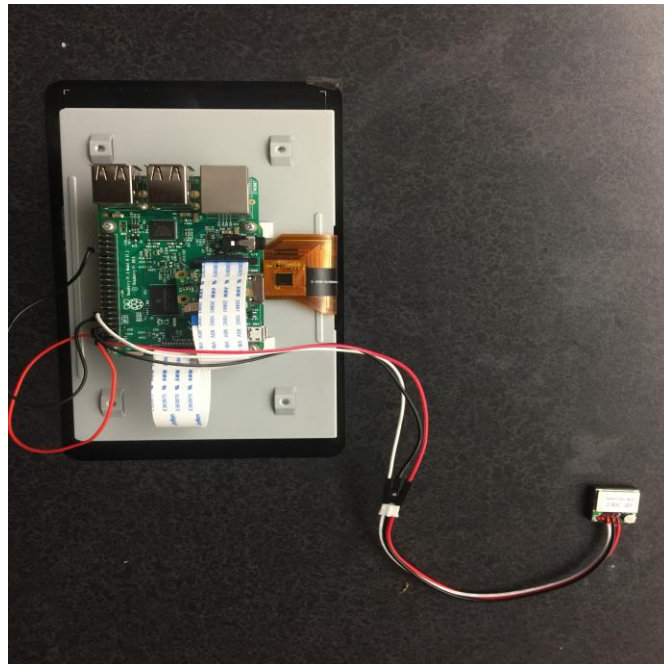
## 7.4 GPS Testing

**56 Channel GPS Receiver (GP-20U7)** The GP-20U7 is a compact GPS receiver with a built-in high performances all-in-one GPS chipset. The GP-20U7 accurately provides position, velocity, and time readings as well possessing high sensitivity and tracking capabilities. Thanks to the low power consumption this receiver requires, the GP-20U7 is ideal for portable applications such as tablet PCs, smartphones, and other devices requiring positioning capability. This 56-channel GPS module, that supports a standard NMEA-0183 and uBlox 7 protocol, has low power consumption of 40mA@3.3V (max), an antenna on board, and -162dBm tracking sensitivity. With 56 channels in search mode and 22 channels “all-in-view” tracking, the GP-20U7 is quite the workhorse for its size.

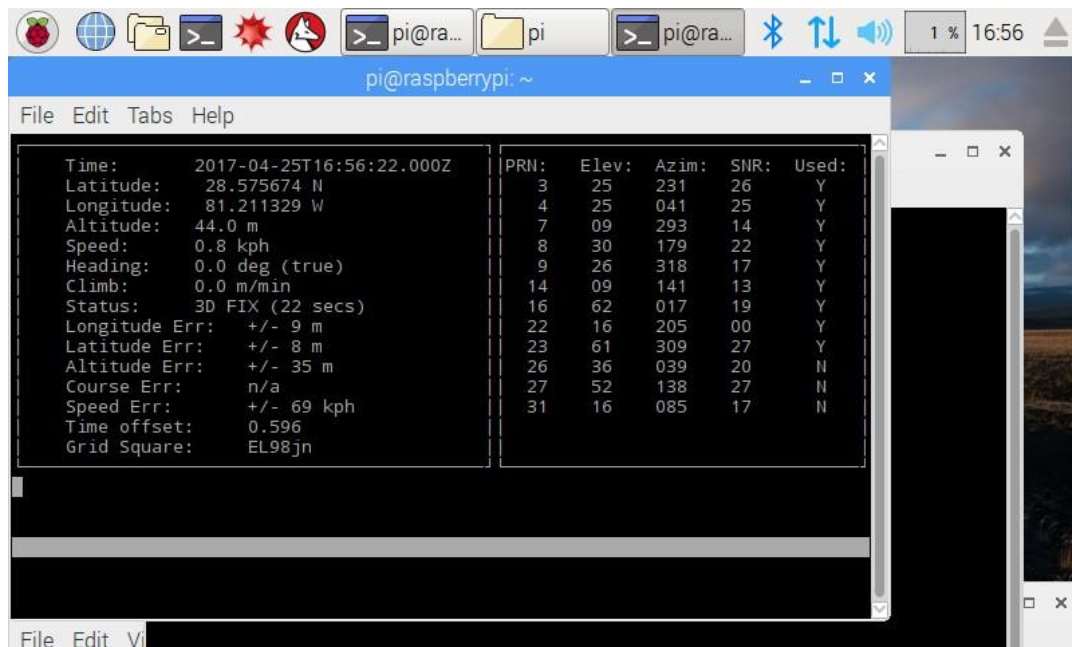
### 7.4.1 GPS Device Receive Data Test

**Test Objective:** Install and run the GPS device.

**Result:** GPS device tracking and activated properly.



**Figure 73: GPS UART Wiring for Raspberry Pi**



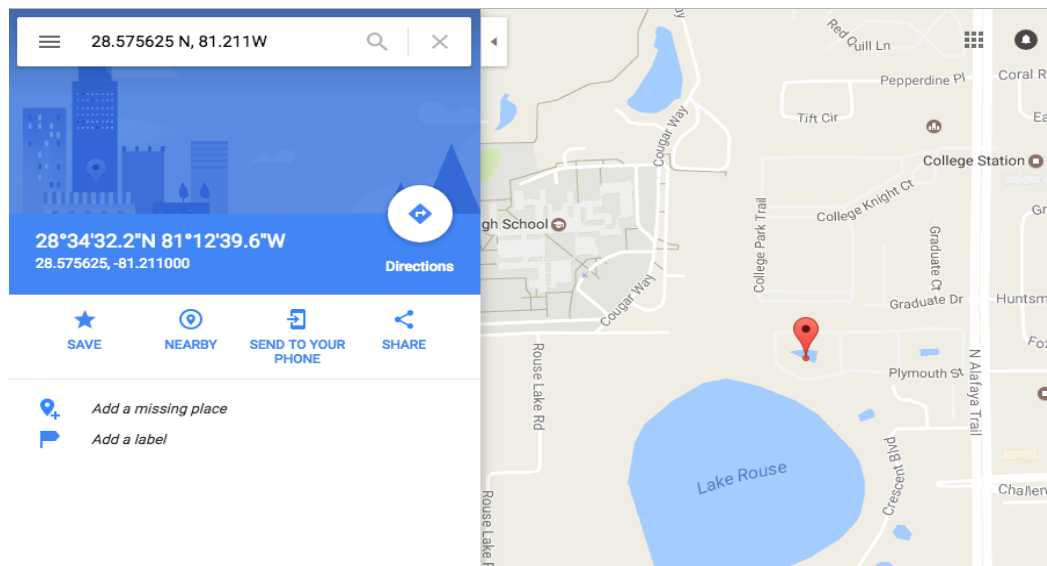
**Figure 74: GPS Component Receiving Data**

### GPS Software Installation:

The first step is installing some software on your Raspberry Pi that understands the serial data that your GPS module is providing via `/dev/ttyS0`.

Since properly parsing the raw GPS data, and we can use (amongst other options) a nice

little package named 'gpsd', which essentially acts as a layer between your applications and the actual GPS hardware, gracefully handling parsing errors, and providing a common, well-defined interface to any GPS module. This service has systemd listen on a local socket and run gpsd when clients connect to it, however it will also interfere with other gpsd instances that are manually run. You will need to disable the gpsd systemd service. Start gpsd and direct it to use HW UART and run cgps -s which gives a less detailed, but still quite nice output.



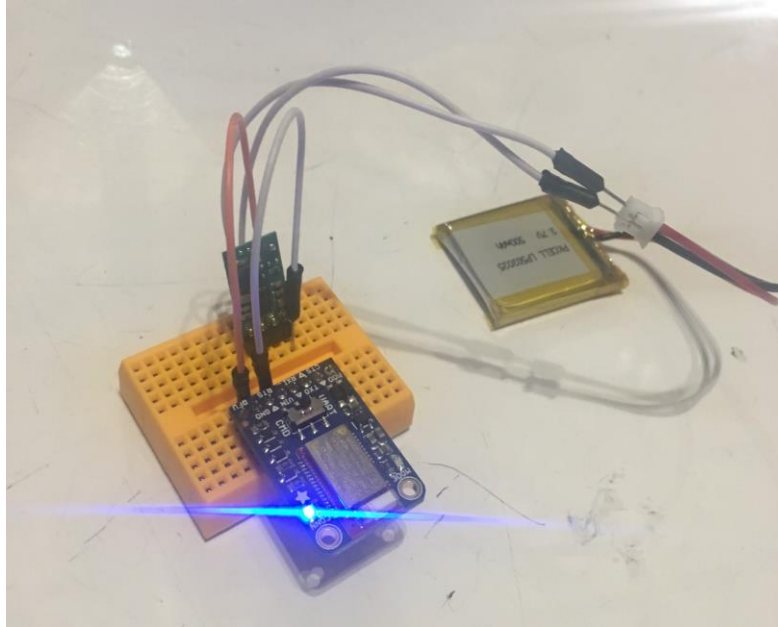
**Figure 75: Verified the location coordinates given by GPS are accurate**

**Constraints:** While the test on the GPS was done by connecting the device to the microcontroller. Problems arose when testing inside, thus GPS was unable to recognize its location. Better reception was achieved when moved next to the window or outdoors.

#### **7.4.2 BlueFruit LE UART Device Powered by Battery Test Combined**

**Test Objective:** An integration test was done connecting the battery, voltage regulator, and microcontroller to the Bluetooth device.

**Result:** The Bluetooth device indicated a correct connection based on the red flashing LED for power and blue LED for connectivity.



**Figure 76: Bluetooth Powered with Battery and Voltage Regulator**

## 7.5 OLED Display Testing

The driver chip, SSD1306 can communicate in multiple ways including I2C, SPI and 8-bit parallel. However, only the 128x64 display has all these interfaces available. This display is small, only about 1" diagonal, but very readable due to the high contrast of an OLED display. Because the display makes its own light, no backlight is required. This reduces the power required to run the OLED and is why the display has such high contrast.

### 7.5.1 OLED Display Test

**Test Objective:** Install and run the OLED display device.

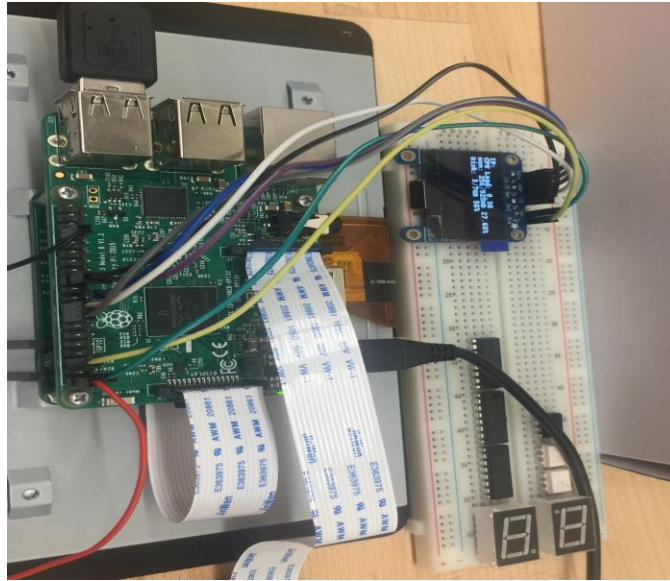
**Result:** Display information and text to OLED display.

#### **OLED Display Software Installation:**

With the Raspberry Pi, install the RPi.GPIO library. Then, install the Python Imaging Library and smbus library. Now to download and install the SSD1306 python library code and examples. Inside the examples subdirectory for shapes.py and stats.py.

#### **Other Software Configurations:**

Along with the size of the display you also configure what interface the display uses in these lines. The first couple examples use the I2C interface and only need to specify an RST pin. Internally the SSD1306 library will look up the default I2C bus number for the platform and use it--if you've followed the wiring in this guide you should be all set! However, if you need to explicitly control the I2C bus number, the third example shows how to specify it with an `i2c_bus` parameter.



**Figure 77: OLED Display Wiring to Raspberry Pi**



**Figure 78: OLED Display demonstration executing shapes.py**

## 7.6 Accelerometer Testing

The LIS3DH is a very popular low power triple-axis accelerometer. This sensor communicates over I2C or SPI (our library code supports both) so you can share it with a bunch of other sensors on the same I2C bus. There's an address selection pin so you can have two accelerometers share an I2C bus.

### 7.6.1 Accelerometer Test

**Test Objective:** Install and run Accelerometer

**Result:** Display information for Accelerometer

#### Acceleration Software Installation:

With the Raspberry Pi, install the RPi.GPIO library. Then, git install the python-lis3dh library and run the testLIS3DH.py

```
x = -0.4336996G, y = -0.9728937G, z = 0.4190476G
x = -0.470818G, y = -0.7990232G, z = 0.3067155G
x = -0.4102564G, y = -0.8136751G, z = 0.5304029G
x = -0.4395604G, y = -0.84884G, z = 0.5128205G
x = -0.2412698G, y = -0.7706959G, z = 0.5509157G
x = -0.2705739G, y = -0.8722832G, z = 0.5753357G
x = -0.1465201G, y = -0.7892551G, z = 0.6466422G
x = -0.1338217G, y = -0.7833943G, z = 0.647619G
x = -0.1103785G, y = -0.7081807G, z = 0.6993895G
x = -0.1797314G, y = -0.4131868G, z = 0.9592185G
x = -0.2901099G, y = -0.1494505G, z = 0.9064713G
x = -0.004884005G, y = 0.004884005G, z = 0.9924297G
x = 0.0G, y = -0.004884005G, z = 0.9885225G
x = -0.002930403G, y = -0.0009768009G, z = 0.9748473G
x = -0.002930403G, y = -0.002930403G, z = 0.9787545G
x = -0.001953602G, y = -0.002930403G, z = 0.9787545G
x = -0.007814407G, y = -0.002930403G, z = 0.9787545G
x = 0.001953602G, y = -0.005860806G, z = 0.9728937G
x = 0.004884005G, y = -0.001953602G, z = 0.9797314G
x = 0.0G, y = -0.0009768009G, z = 0.9797314G
x = 0.0009768009G, y = -0.002930403G, z = 0.991453G
x = -0.001953602G, y = -0.002930403G, z = 0.9748473G
x = -0.002930403G, y = -0.005860806G, z = 0.9807081G
```

Figure 79: Accelerometer outputting three-directional axis to the terminal

## 7.7 Pulse Sensor Testing

The Gravity Heart Rate Monitor Sensor is a pulse sensor which is developed based on PPG (PhotoPlethysmoGraphy) techniques. This is a simple and low-cost optical technique that can be used to detect blood volume changing in the microvascular bed of tissues. It is relatively easy to detect the pulsatile component of the cardiac cycle according to this theory.

### 7.7.1 Pulse Sensor Test

**Test Objective:** Install and run pulse sensor.

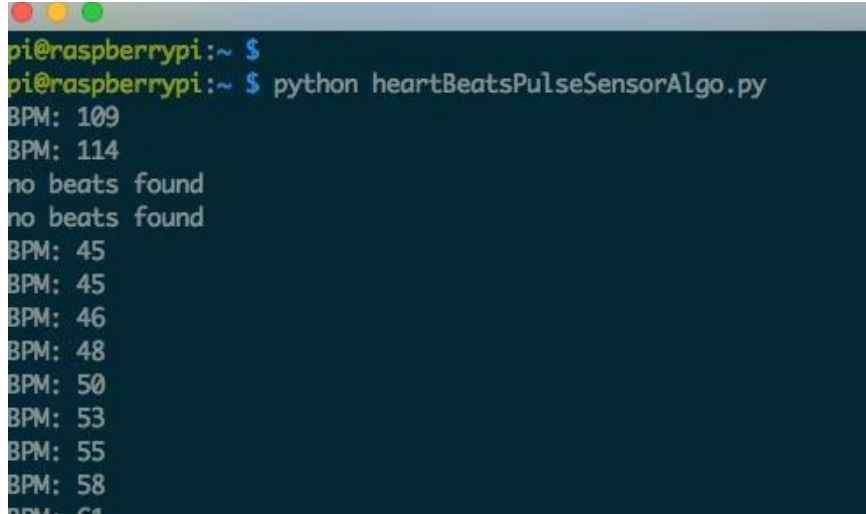
**Result:** Display information for pulse sensor.

#### Acceleration Software Installation:



With the Raspberry Pi, install the RPi.GPIO library. The python to read and process data from the Pulse Sensor and produce Beats per Minute (BPM) or the Heart rate. Configure Raspberry Pi to enable I2C module.

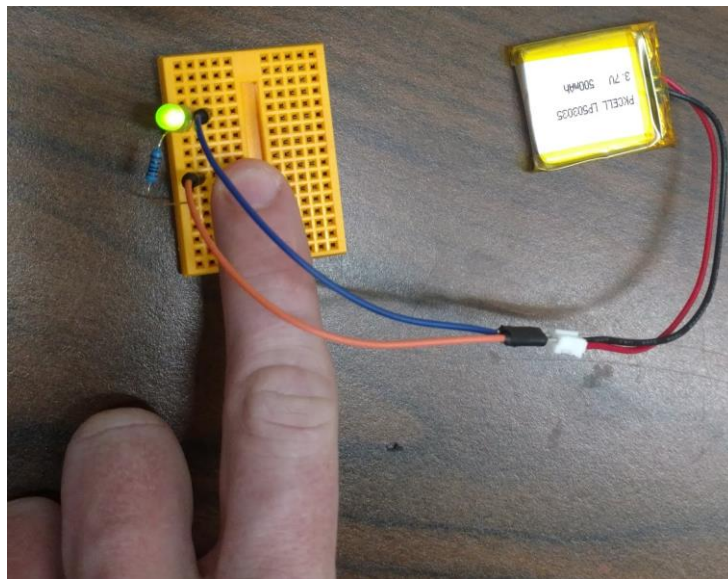
Also, install [https://github.com/adafruit/Adafruit\\_Python\\_ADS1x15](https://github.com/adafruit/Adafruit_Python_ADS1x15).

A terminal window on a Raspberry Pi showing the execution of a Python script named 'heartBeatsPulseSensorAlgo.py'. The output displays a series of heart rate measurements in beats per minute (BPM) and some instances where no beats were found. The measurements are: 109, 114, no beats found, no beats found, 45, 45, 46, 48, 50, 53, 55, 58, and 61.

```
pi@raspberrypi:~ $  
pi@raspberrypi:~ $ python heartBeatsPulseSensorAlgo.py  
BPM: 109  
BPM: 114  
no beats found  
no beats found  
BPM: 45  
BPM: 45  
BPM: 46  
BPM: 48  
BPM: 50  
BPM: 53  
BPM: 55  
BPM: 58  
BPM: 61
```

**Figure 80: Pulse Sensor output to Terminal**

## 7.8 Pushbutton Testing



**Figure 81: Push Button Breadboarding**

Figure 81 shows the simple testing of the push button. The button is attached to an LED to understand how the push button leads pass current. The battery was used as a power supply, but no voltage regulator was used to drop the voltage, because it was not necessary.

## **7.9 Overall System Testing**

Once testing has been completed and completely integrated into the final design and schematic, the team will conduct multiple tests to check the overall system performance. Adjustments will be made to the design until the results from the tests meet the required specifications.

The prototype of the Bioelectric Smartwatch will be tested on varying age groups for performance analysis. Our team has acquired multiple test subjects to help provide data for our tests. As a comparison to the health monitoring tests on our device, we will be able to check the readings that are obtained with existing health monitoring tools. This will allow us to check accuracies and fix any bugs that may have occurred.

The primary tests involve will involve gauging the life expectancy of the Bioelectric Smartwatch under different conditions. These conditions include one test where the Bioelectric Smartwatch has little to no use. Another test will be done where the Bioelectric Smartwatch will be used extensively. This type of testing will look to see how quickly the battery of the Bioelectric Smartwatch drains.

The next tests will be on the individual health monitoring systems. For the pulse sensor, measurements will be taken for a person who is at rest to obtain their average beats per minute (BPM). Once this average has been calculated, another test will be done shortly after someone has exerted themselves to get their BPM, which should be higher than their BPM at rest. For the temperature sensor, a test will be done in a similar fashion to the pulse sensor tests. For the accelerometer, measurements will be taken for a person at rest and immediately after excessive hand movement, which can be caused by physical activities or tremors in a user's hand.

The next test that will be done are on the communication systems. The Bluetooth system will be tested by connecting the Bioelectric Smartwatch to smartphones that are on different platforms. This will ensure that the Bioelectric Smartwatch is compatible with any device. The GPS system will be tested by checking to see if the system can determine if a signal can be picked up from indoors as well as outdoors. This will ensure that if an emergency were to occur, the authorities will be able to locate the user, no matter where they are.

## **7.10 Overall System Testing in Senior Design 2**

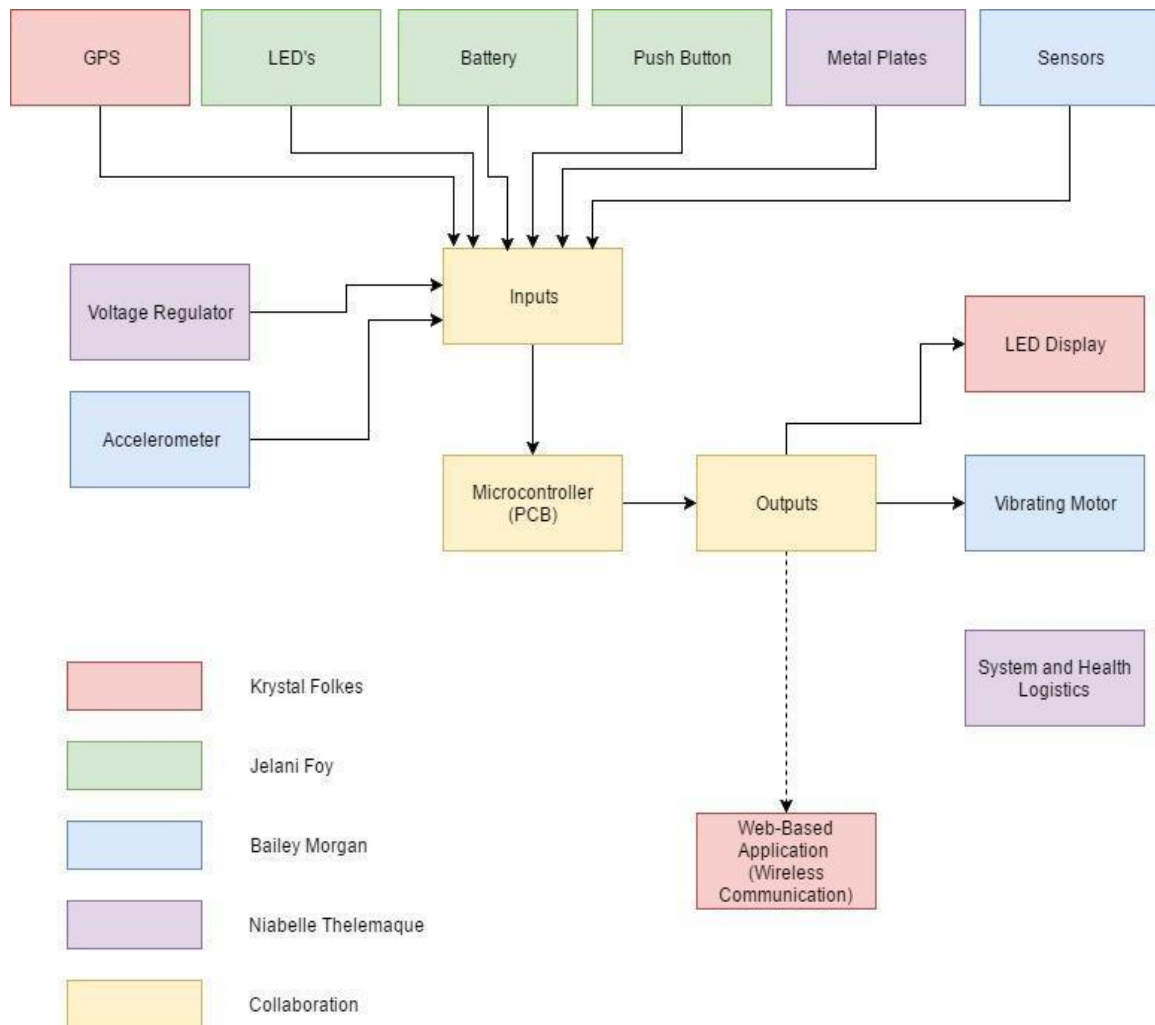
Once all the components were acquired in Senior Design 2, prototyping of the entire board commenced. Connections were altered depending on the functionality of the peripherals. To test the board, coding was done in Arduino. The GPS system worked partially in the Engineering 1 building. It was discovered that the GPS system worked best outdoors. After further trial and error, the breadboard was able to function exactly how the final project would run.

## 8.0 Administrative Content

This portion of the document will be used to describe how well the group can effectively manage time as well as portray logistics of the budget for this project. This section lists different due dates, as well as timelines for each significant event from the kickoff of the project up to the time that the final document is due.

### 8.1 Initial Project Diagram

Figure 82 below shows a diagram of how the work will be split in the team. The roles are divided by color and are assigned per the legend at the bottom. Roles and subject boxes are subjected to change during the implementation of the product.



**Figure 82: Block Diagram of Assigned Roles**

The initial project diagram is important because it laid the foundation of the project, and researching the project. The goal of the initial project design is to get an idea of how every component will be connected in a high-level sense. The initial project design was the task assigned at the beginning of senior design, when the first 10-page draft was assigned. This

design will possibly change in the near future because it was only an initial design, but it is important nonetheless.

## 8.2 Budget

The prices listed below in Table 32 are the prices of the components used in the Bioelectric Smartwatch. The place column refers to 8.2.1.

**Table 32: Project Budget Table**

Item	Place	Manufacturer	Price/Unit	Unit	Total
Accelerometer	A	Sparkfun	\$8.06	1	\$8.06
OLED Display	B	Adafruit	\$19.95	1	\$19.95
Motor Disc	C	Adafruit	\$1.95	1	\$1.95
Pulse Monitor	D	DFRobot	\$16.00	1	\$16.00
Lithium Ion Battery	E	Adafruit	\$7.95	1	\$7.95
Voltage Regulators	F/G	Pololu/ Digikey	\$8.99	1	\$8.99
Button Switch	H	Adafruit	\$0.27	3	\$0.81
Battery Charger	I	Adafruit	\$6.95	1	\$6.95
GPS Receiver	J	Sparkfun	\$15.95	1	\$15.95
Bluefruit LE UART	K	Adafruit	\$17.50	1	\$17.50
PCB		PCB Way	\$28.00	1	\$28.00
Total					\$132.11

### Note

- These values are an estimate based on products already in the market.

- Total price will be divided by four.

### 8.2.1 Components of final PCB

Refer to Table 32 for the placement of the components for the soldered PCB.

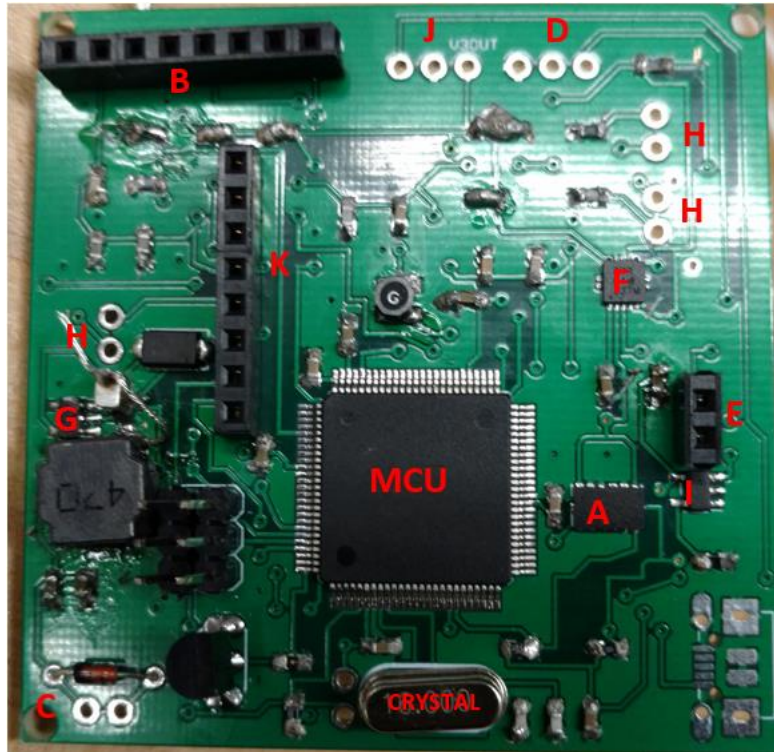


Figure 83: PCB with soldered components

### 8.3 Project Milestones

Table 33 and Table 34 below show the initial project milestones we will complete in Senior Design 1 and Senior Design 2. We will use this to serve as a reference to ensure that we are on track to complete the documentation and final product in a timely manner.

**Table 33: Senior Design 1 Projected Schedule**

<b>Description</b>	<b>Duration</b>	<b>Dates</b>
<b>Project Idea</b>	<b>1 week</b>	January 9- January 13
<b>Divide and Conquer</b>	<b>3 weeks</b>	January 13- February 3
<b>Initial Project Document</b>	-	February 3
<b>Research and Writing</b>	<b>2 weeks</b>	February 3- February 17
<b>Update on Divide and Conquer</b>	-	February 17
<b>Individual Research and Writing</b>	<b>5 weeks</b>	February 17- March 24
<b>Table of Contents</b>	-	March 24
<b>Initial Draft</b>	-	March 31
<b>Final Document</b>	-	April 27

**Table 34: Senior Design 2 Projected Schedule**

<b>Week</b>	<b>Description</b>
1	Test Components
2-6	Build Prototype
7-8	Test Prototype
9-11	Finalize Prototype
12	Present Project

## 9.0 Conclusions

Designing the Bioelectric Smartwatch has been an overall challenging and rewarding experience. Designing and testing the Bioelectric Smartwatch incorporated all the skills that were learned while studying the electrical and computer engineering disciplines. Many obstacles were encountered while designing the project. Some of these obstacles and problems were encountered in the testing phase. One of these issues being that the GPS receiver had problems sending a signal to our board and was not working properly when it was tested inside of many buildings. The success of testing the other components, however, show that the smartwatch is closer to becoming a completed product.

The cutting-edge technologies that have been implemented in the design of this project are pulse oximetry, accelerometer measurements, and GPS tracking. Pulse oximetry is the newest technology out of every type of technology being implemented, and thus is the most difficult to implement. The method of getting heart rate from pulse oximetry will make for a successful fitness tracking watch because it is the forefront technology of heart rate monitors. Integrating the pulse oximetry will be the biggest accomplishment of the smartwatch design.

Some of the biggest challenges that the group faced was changing microcontrollers halfway through the Senior Design 2 semester. This caused issues with the PCB designs due to the new pin layout. Another issue is that the majority of the components are surface mount. This made prototyping difficult to do, especially if a component was soldered incorrectly. For the peripheral components, the accelerometer proved to be the most difficult because it needed to be calibrated to count the steps to replicate arm movement. Any adjustment to this component also needed to be adjusted in the code for the accelerometer. Lastly, the Bluetooth and pulse sensor remained on their boards. The Bluetooth board had many vital components that could be easily destroyed if not properly removed. The pulse sensor also remained on the board because it became difficult to rebuild the sensor for the smartwatch's use. It also was difficult to determine the components used to build the pulse sensor.

One of the major takeaways from this project has been working together as a team, in order to take what was just an idea to becoming a tangible product of our creation. Due to the nature of our product, we be creating something that will help the well-being of people was the motivating factor of this project, and will motivate the group to work hard on the final design.

The main idea behind this project is to bring a product to the market that helps the elderly and sick live a safer and healthier lifestyle. This product will be able to satisfy the need of this market by using cutting edge technology. The Bioelectric Smartwatch will be the first of its kind to mesh fitness tracking abilities with the added of safety of an emergency GPS beacon.

### 9.1 Possible Future Considerations

An alternative idea to this project is to include accessories, increasing the number of

features to the Bioelectric Smartwatch. One additional feature would be to measure a user's blood pressure. However, instead of incorporating this health monitoring device within the Bioelectric Smartwatch, an accessory can be used instead. This accessory would be a blood pressure cuff, gauge, and bulb that can be attached to the smartwatch so that the smartwatch would serve as the digital monitor. The cuff would be inflated by squeezing the bulb until the gauge reaches a specified value. Then the user will read the systolic pressure calculated by the watch.

Another accessory would be to measure body fat percentage through bioelectrical impedance analysis. This analysis measures the body's electrical resistance. Body fat will be measured with the use of two electrodes that are safely attached to the body. One electrode would be placed underneath the face of the smartwatch, contacting the skin of the user. The other electrode would be created in the form of an attachable band that can be placed on a user's ankle.

Thought research suggested feature that could be added was speech recognition. This case was proposed due to about 90 percent of people with Parkinson's disease (PD) experience decreased functional communication due to the presence of voice and speech disorders associated with dysarthria that can be characterized by monotony of pitch (or fundamental frequency), reduced loudness, irregular rate of speech, imprecise consonants, and changes in voice quality. This feature would help and aid in speech treatment processes and help the recovery of common diseases.



## 10.0 Appendices

This section is to show the material used as reference throughout this report, and to show the permissions requested for this material and images.

### 10.1 Bibliography

- [1] T. Agarwal, "Types of Temperature Sensors and Their working Principles | Features", *EIProCus - Electronic Projects for Engineering Students*, 2017. [Online]. Available: <https://www.elprocus.com/temperature-sensors-types-working-operation/>. [Accessed: 25- Apr- 2017].
- [2] E. Denton, "Learn How to Measure Body Temperature Accurately and Cost Effectively", *Texas Instruments*, 2015. [Online]. Available: <http://www.ti.com/lit/ml/slyw051/slyw051.pdf>. [Accessed: 25- Apr- 2017].
- [3]"What is 3d printing? | 3D Printing from scratch", *3D Printing from scratch*, 2017. [Online]. Available: <http://3dprintingfromscratch.com/common/what-is-3d-printing/>. [Accessed: 25- Apr- 2017].
- [4]"Switch Basics - learn.sparkfun.com", *Learn.sparkfun.com*, 2017. [Online]. Available: <https://learn.sparkfun.com/tutorials/switch-basics>. [Accessed: 25- Apr- 2017].
- [5]"The Light Emitting Diode", *Electronics Tutorials*, 2014. [Online]. Available: [http://www.electronics-tutorials.ws/diode/diode\\_8.html](http://www.electronics-tutorials.ws/diode/diode_8.html). [Accessed: 25- Apr- 2017].
- [6] I. Poole, "Schottky Diode | Characteristics Specifications | Tutorial", *Radio-electronics.com*, 2017. [Online]. Available: [http://www.radio-electronics.com/info/data/semicond/schottky\\_diode/characteristics-specifications-parameters.php](http://www.radio-electronics.com/info/data/semicond/schottky_diode/characteristics-specifications-parameters.php). [Accessed: 25- Apr- 2017].
- [7]"Introduction to Diodes And Rectifiers | Diodes and Rectifiers | Electronics Textbook", *Allaboutcircuits.com*, 2017. [Online]. Available: <https://www.allaboutcircuits.com/textbook/semiconductors/chpt-3/introduction-to-diodes-and-rectifiers/>. [Accessed: 25- Apr- 2017].
- [8]"Diodes - learn.sparkfun.com", *Learn.sparkfun.com*, 2017. [Online]. Available: <https://learn.sparkfun.com/tutorials/diodes>. [Accessed: 25- Apr- 2017].

- [9]"Fitness and wearable activity monitor block diagram| TI.com", *Ti.com*, 2017. [Online]. Available: <http://www.ti.com/solution/fitness-activity-monitors>. [Accessed: 26- Apr- 2017].
- [10]"AFE4400 Integrated Analog Front End for Heart Rate Monitors and Low Cost Pulse Oximeters | TI.com", *Ti.com*, 2017. [Online]. Available: <http://www.ti.com/product/afe4400>. [Accessed: 26- Apr- 2017].
- [11]2017. [Online]. Available: <http://electronicdesign.com/digital-ics/build-wrist-heart-rate-monitor-using-ultra-low-power-mcu> - Amazing explanation of pulse sensor design. [Accessed: 26- Apr- 2017].
- [12] M. Szczys, "Pulse Oximeter from LM324, LED, and Photodiode", *Hackaday*, 2017. [Online]. Available: <http://hackaday.com/2013/04/18/pulse-oximeter-from-lm324-led-and-photodiode/>. [Accessed: 26- Apr- 2017].
- [13]"Pulse oximetry", *En.wikipedia.org*, 2017. [Online]. Available: [https://en.wikipedia.org/wiki/Pulse\\_oximetry](https://en.wikipedia.org/wiki/Pulse_oximetry). [Accessed: 26- Apr- 2017].
- [14]2017. [Online]. Available: [https://github.com/Protocentral/AFE4490\\_Oximeter/blob/master/Hardware/pc\\_afe4490\\_shield\\_v2/pc\\_afe44xx\\_shield\\_v2.pdf](https://github.com/Protocentral/AFE4490_Oximeter/blob/master/Hardware/pc_afe4490_shield_v2/pc_afe44xx_shield_v2.pdf). [Accessed: 26- Apr- 2017].
- [14] S. ADXL335, S. ADXL337, S. ADXL377 and S. ADXL362, "Accelerometer Basics - learn.sparkfun.com", *Learn.sparkfun.com*, 2017. [Online]. Available: <https://learn.sparkfun.com/tutorials/accelerometer-basics>. [Accessed: 26- Apr- 2017].
- [15]"How to Build an Accelerometer Circuit", *Learningaboutelectronics.com*, 2017. [Online]. Available: <http://www.learningaboutelectronics.com/Articles/Accelerometer-circuit.php>. [Accessed: 26- Apr- 2017].
- [16]2017. [Online]. Available: <https://ocw.mit.edu/courses/electrical-engineering-and-computer-science/6-777j-design-and-fabrication-of-microelectromechanical-devices-spring-2007/lecture-notes/07lecture24.pdf>. [Accessed: 26- Apr- 2017].
- [17] Colibrys, "Advantage of capacitive MEMS accelerometers vs other technologies", *Slideshare.net*, 2017. [Online]. Available: <https://www.slideshare.net/Colibrys/advantage-of-capacitive-mems-accelerometers-vs-other-technologies>. [Accessed: 26- Apr- 2017].
- [18]"Piezoelectric accelerometer", *En.wikipedia.org*, 2017. [Online]. Available: [https://en.wikipedia.org/wiki/Piezoelectric\\_accelerometer](https://en.wikipedia.org/wiki/Piezoelectric_accelerometer). [Accessed: 26- Apr- 2017].

- [19]"Overview | Arduino Lesson 13. DC Motors | Adafruit Learning System", *Learn.adafruit.com*, 2017. [Online]. Available: <https://learn.adafruit.com/adafruit-arduino-lesson-13-dc-motors>. [Accessed: 26- Apr- 2017].
- [20]"OLED 4K TV VS. LCD 4K TV: Your comprehensive comparison across key specs -", *4k.com*, 2017. [Online]. Available: <http://4k.com/oled-4k-tvs-vs-lcd-4k-tvs-the-comparison-across-8-key-points-12320-2/>. [Accessed: 26- Apr- 2017].
- [21]"Inductive Power Transmission", *Wirelesspowerconsortium.com*, 2017. [Online]. Available: <https://www.wirelesspowerconsortium.com/technology/basic-principle-of-inductive-power-transmission.html>. [Accessed: 26- Apr- 2017].
- [22]"Introduction to Wireless Battery Charging | IDT", *Idt.com*, 2017. [Online]. Available: <https://www.idt.com/products/power-management/wireless-power/introduction-to-wireless-battery-charging>. [Accessed: 26- Apr- 2017].
- [23]"Fundamentals of battery fuel-gauging", *Electronic Component News*, 2017. [Online]. Available: <https://www.ecnmag.com/article/2012/11/fundamentals-battery-fuel-gauging>. [Accessed: 26- Apr- 2017].
- [24] m. kareirea, "Wiring Diagram Remote Control", *Rcwirring.blogspot.com*, 2017. [Online]. Available: [http://rcwirring.blogspot.com/2014\\_02\\_01\\_archive.html](http://rcwirring.blogspot.com/2014_02_01_archive.html). [Accessed: 26- Apr- 2017].
- [25]"Push Button Switch Schematic - Nilza.net", *Nilza.net*, 2017. [Online]. Available: <http://nilza.net/mainpage/detail/push-button-switch-schematic>. [Accessed: 26- Apr- 2017].
- [26]"Smart Watch Display Technology Shoot-Out", *Displaymate.com*, 2017. [Online]. Available: [http://www.displaymate.com/Smart\\_Watch\\_ShootOut\\_1.htm](http://www.displaymate.com/Smart_Watch_ShootOut_1.htm). [Accessed: 26- Apr- 2017].
- [27]"How do LCDs (liquid crystal displays) work?", *Explain that Stuff*, 2017. [Online]. Available: <http://www.explainthatstuff.com/lcdtv.html>. [Accessed: 26- Apr- 2017].
- [28]"EXCLUSIVE: What's inside a smart watch?", *Global Sources*, 2017. [Online]. Available: <http://www.globalsources.com/gsol/I/Smart-watch/a/9000000132594.html>. [Accessed: 26- Apr- 2017].
- [29]"IEEE Standard for Rechargeable Batteries for Multi-Cell Mobile Computing Devices - Redline - IEEE Xplore Document", *Ieeexplore.ieee.org*, 2017. [Online]. Available: <http://ieeexplore.ieee.org/document/5982066/>. [Accessed: 26- Apr- 2017].
- [30]"IEEE Standard Definitions and Concepts for Dynamic Spectrum Access: Terminology Relating to Emerging Wireless Networks, System Functionality, and

- Spectrum Management Amendment 1: Addition of New Terms and Associated Definitions - IEEE Xplore Document", *Ieeexplore.ieee.org*, 2017. [Online]. Available: <http://ieeexplore.ieee.org/document/6422300/>. [Accessed: 26- Apr- 2017].
- [31]"IPC Printed Board Defense Roadmap to Be Released at IPC Technology Interchange | IPC", *Ipc.org*, 2017. [Online]. Available: <http://www.ipc.org/contentpage.aspx?pageid=IPC-Printed-Board-Defense-Roadmap-to-Be-Released-at-IPC-Technology-Interchange>. [Accessed: 26- Apr- 2017].
- [32]"Links To Required Workmanship Standards", *Nepp.nasa.gov*, 2017. [Online]. Available: <https://nepp.nasa.gov/index.cfm/5544>. [Accessed: 26- Apr- 2017].
- [33]"GPS Navigation Manufacturer - Mio Technology", *Mio.com*, 2017. [Online]. Available: <http://www.mio.com/>. [Accessed: 26- Apr- 2017].
- [34]"Bluetooth", *En.wikipedia.org*, 2017. [Online]. Available: <https://en.wikipedia.org/wiki/Bluetooth>. [Accessed: 26- Apr- 2017].
- [35]"Wi-Fi", *En.wikipedia.org*, 2017. [Online]. Available: <https://en.wikipedia.org/wiki/Wi-Fi>. [Accessed: 26- Apr- 2017].
- [36]"IEEE Recommended Practice For General Principles Of Temperature Measurement As Applied To Electrical Apparatus - IEEE Xplore Document". *Ieeexplore.ieee.org*. N.p., 2017. Web. 26 Apr. 2017.
- [37]"Wireless Local Area Network Assisted GPS in Seamless Positioning - IEEE Xplore Document", *Ieeexplore.ieee.org*, 2017. [Online]. Available: <http://ieeexplore.ieee.org/document/6188248/>. [Accessed: 26- Apr- 2017].
- [38]"Health Informatic--Personal Health Device Communication Part 10441: Device Specialization--Cardiovascular Fitness and Activity Monitor - IEEE Xplore Document". *Ieeexplore.ieee.org*. N.p., 2017. Web. 26 Apr. 2017.
- [39]"IEEE Standard for Smart Transducer Interface for Sensors and Actuators-- Transducers to Radio Frequency Identification (RFID) Systems Communication Protocols and Transducer Electronic Data Sheet Formats - IEEE Xplore Document", *Ieeexplore.ieee.org*, 2017. [Online]. Available: <http://ieeexplore.ieee.org/document/5494713/>. [Accessed: 26- Apr- 2017].
- [40]"Health informatics Personal health device communication Part 10404: Device specialization Pulse oximeter - IEEE Xplore Document", *Ieeexplore.ieee.org*, 2017. [Online]. Available: <http://ieeexplore.ieee.org/document/6235069/>. [Accessed: 27- Apr- 2017].

- [41] C. Khorakhun, and S. N. Bhatti. "MHealth through Quantified-Self: A User Study". 2015 17th International Conference on E-health Networking, Application & Services (HealthCom). Web.
- [42] Josette M. Bianchi-Hayes, Elinor R. Schoenfeld, Rosa Cataldo, Jiayu Huang, and Susmita Pati, "Caregiver Preferences regarding Technology's Role in Supporting Adolescent Weight Management," *International Scholarly Research Notices*, vol. 2015, Article ID 153723, 12 pages, 2015. doi:10.1155/2015/153723
- [43] T. H. Tan, et al. "Indoor Activity Monitoring System for Elderly using RFID and Fitbit Flex Wristband". *IEEE-EMBS International Conference on Biomedical and Health Informatics (BHI)*. Web
- [44] Wisniewski, Pamela; Turgut, Damla; Chen, Kim "Leveraging the FitBit API to Share Activity Levels with a Trusted Caregiver" , Department of Computer Science at the University of Central Florida, NSF
- [45] Scanail, C. N., Carew, S., Barralon, P., Noury, N., Lyons, D., & Lyons, G. M. (2006). A Review of Approaches to Mobility Telemonitoring of the Elderly in Their Living Environment. *Annals of Biomedical Engineering*, 34(4), 547–563. Web.
- [46] Boise, L., Wild, K., Mattek, N., Ruhl, M., Dodge, H. H., & Kaye, J. (2013). Willingness of older adults to share data and privacy concerns after exposure to unobtrusive inhome monitoring. *Gerontechnology : International Journal on the Fundamental Aspects of Technology to Serve the Ageing Society*, 11(3), 428–435. Web.
- [47] Chiauzzi, E., Rodarte, C., & DasMahapatra, P. (2015). Patient-centered activity monitoring in the self-management of chronic health conditions. *BMC Medicine*, 13, 77. Web.
- [48] Takacs, J., Pollock, C. L., Guenther, J. R., Bahar, M., Napier, C., & Hunt, M. A. (2014). Validation of the Fitbit One activity monitor device during treadmill walking. *Journal of Science and Medicine in Sport*, 17(5), 496–500. Web.
- [49] Pentland, A. (2004). Healthwear: medical technology becomes wearable. *Computer*, 37(5), 42–49. Web.
- [50] Wisniewski, Pamela; Chen, Kim "Leveraging the Fitbit API to Share Activity Levels with a Trusted Caregiver", Department of Computer Science at the University of Central Florida, NSF

## 10.2 Requested Permissions

First Name :  
Bailey

Last Name :  
Morgan

\*Email Address :  
tantrichdd15@gmail.com

Student - College/University ▼

United States of America ▼

Intellectual Property ▼

\*Comments  
Hello,  
  
I am requesting to use a few images from your website to explain current accelerometer design.  
  
Thank you,  
Bailey Morgan

Hello,

I am requesting to reference some images and designs from your website into my senior design paper.

Thank you,  
Bailey Morgan

## PR/Media Inquiry

Niabelle

Thelemaque

niabelle\_thelemaque@knights.ucf.edu

Receive updates from Fitbit

United States

Good evening,

My name is Niabelle Thelemaque and I am an electrical engineering student at the University of Central Florida. I am writing to request permission to reference the figures from your website, specifically the [Fitbit Alta HR](#) for a technical document that I am working on.

Please get back to me at this email, [niabelle\\_thelemaque@knights.ucf.edu](mailto:niabelle_thelemaque@knights.ucf.edu) or at (954) 850-0573.

Thank you for your help.

Sincerely,

Niabelle Thelemaque

OMEGA E-mail Boxes:	General Information
*First Name:	Niabelle
*Last Name:	Thelemaque
*Company Name:	University of Central Florida
*Company Address:	4000 Central Blvd.
*City:	Orlando
State/Province:	Florida
*Country:	USA
Zip:	32816
*E-mail Address:	niabelle_thelemaque@knights.ucf.edu
*Phone Number:	9548500573
Fax Number:	
*Subject:	Permission to use figures/ information
*Message:	<p>Good evening,</p> <p>My name is Niabelle Thelemaque and I am an electrical engineering student at the University of Central Florida. I am writing to request permission to reference the figures/information from your website for a technical document that I am working on. Please get back to me at this email, <a href="mailto:niabelle_thelemaque@knights.ucf.edu">niabelle_thelemaque@knights.ucf.edu</a> or at (954) 850-0573.</p> <p>Thank you for your help.</p> <p>Sincerely,</p> <p>Niabelle Thelemaque</p>

**First Name**

Bailey

**Last Name**

Morgan

**Email Address**

tantrichdd15@gmail.com

**Company Name**

University of Central Florida

**Title/Position**

Student

**Phone Number**

407-520-1899

**Fax**

**Describe your Request**


Hello,

I am requesting to use an image of the apple watch so use as a reference to current smart watch technology.

Thank you,  
Bailey Morgan



## Senior Design Information Request


 Jelani Foy  
Wed 4/26/2017 3:07 PM  
To: webmaster@idt.com

Hello,

My name is Jelani Foy. I am an Electrical Engineering student at the University of Central Florida. I am currently working on a senior design project, and I would like to reproduce some images from your website information on the components of wireless battery charging. I am writing to request permission to refer to these pictures in the technical document that I am currently working on.

Feel free to get back to me at this email, jfoy22@knights.ucf.edu. Thank you for your assistance.

Regards,  
Jelani Foy

 Jelani Foy  
Wed 4/26/2017 3:20 PM  
To: ti\_karthikkadirvel@list.ti.com


Hello,

My name is Jelani Foy. I am an Electrical Engineering student at the University of Central Florida. I am currently working on a senior design project, and I would like to reproduce some images from your website information on the fundamentals of battery fuel gauging. I am writing to request permission to refer to these pictures in the technical document that I am currently working on.

Feel free to get back to me at this email, jfoy22@knights.ucf.edu. Thank you for your assistance.

Regards,  
Jelani Foy

## Senior Design Information Request

 Jelani Foy  
Wed 4/26/2017 2:38 PM  
To: contact@4k.com


Hello,

My name is Jelani Foy. I am an Electrical Engineering student at the University of Central Florida. I am currently working on a senior design project, and I would like to reproduce some images from your website information on the OLED vs. LCD visualization. I am writing to request permission to refer to these pictures in the technical document that I am currently working on.

Feel free to get back to me at this email, jfoy22@knights.ucf.edu. Thank you for your assistance.

Regards,  
Jelani Foy

## Senior Design Information Request

 Jelani Foy  
Wed 4/26/2017 2:43 PM  
To: support@adafruit.com

Hello,

My name is Jelani Foy. I am an Electrical Engineering student at the University of Central Florida. I am currently working on a senior design project, and I would like to reproduce some images from your website information on the 500mah Lithium-Ion Battery. I am writing to request permission to refer to these pictures in the technical document that I am currently working on.

Feel free to get back to me at this email, jfoy22@knights.ucf.edu. Thank you for your assistance.

Regards,  
Jelani Foy

## Requesting use of images

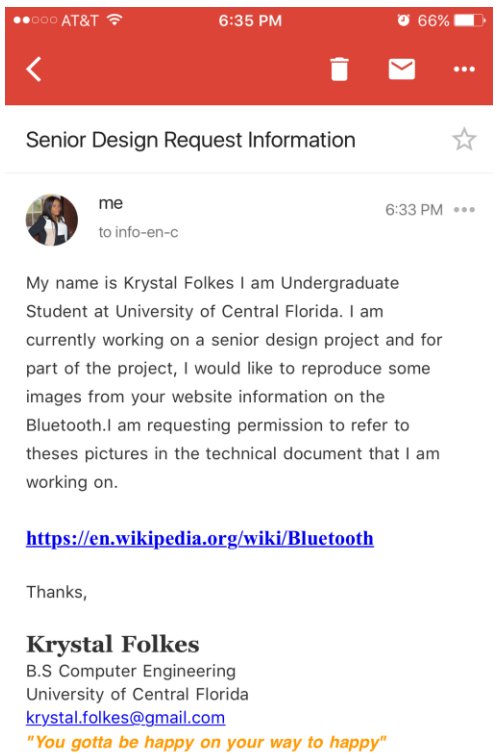
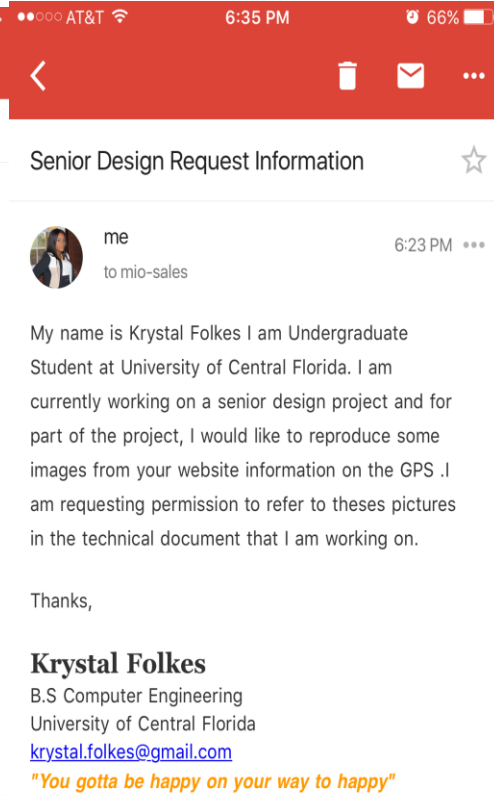
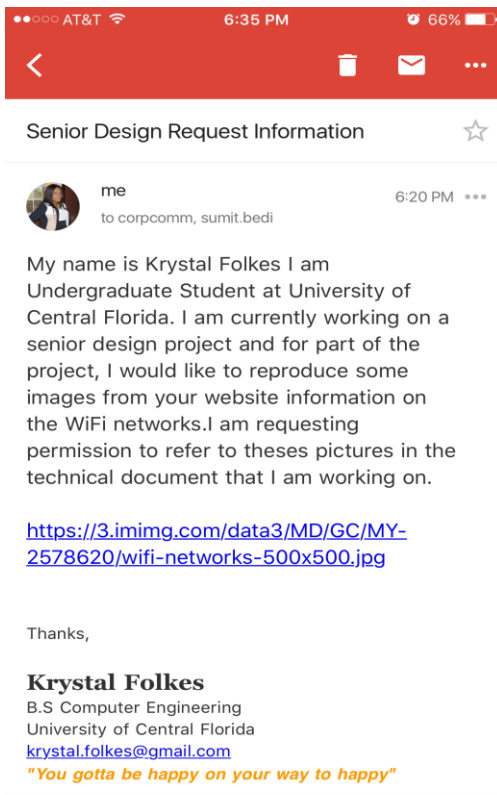
ti-cares@ti.com

## Requesting use of images

Hello,

I am requesting to use some of your images and designs as reference material for my senior design paper. It will be used to explain current smartwatch technology.

Thank you,  
Bailey Morgan



Niabelle Thelemaque  
Today, 6:16 PM  
neamen@eece.unm.edu

Reply all

Hello,

My name is Niabelle Thelemaque and I am an electrical engineering student at the University of Central Florida. I am currently working on a senior design project, and for part of this project, I would like to reproduce some images from your Microelectronics Circuit Analysis and Design, 4th edition textbook. I am writing to request permission to refer to these pictures in the technical document that I am working on. The images I am primarily interested in images pertaining voltage regulators.

Please get back to me at this email, Niabelle\_Thelemaque@knights.ucf.edu or at (954) 850-0573.

Thank you for your help.

Sincerely,

Niabelle Thelemaque

\* Name :

Niabelle Thelemaque

\* Email :

niabelle\_thelemaque@knights.ucf.edu

Are you accessing through a company/university subscription?  Yes

No

If Yes, please indicate the name of the institution:

University Central of Florida

Are you an IEEE Member?  Yes  No

If Yes, please indicate your member number:

Feedback concerning:  Search  Content  Access  Other

Your Comments:

Hello,

My name is Niabelle Thelemaque and I am an electrical engineering student at the University of Central Florida. I am currently working on a senior design project, and for part of this project, I would like to reproduce some images from your website information on standards, specifically from the IEEE Recommended Practice for General Principles of Temperature Measurements as Applied to Electrical Apparatus . I am writing to request permission to refer to these pictures in the technical document that I am working on.

Please get back to me at this email, Niabelle\_Thelemaque@knights.ucf.edu or at (954) 850-0573.

Thank you for your help.

|

Sincerely,

1812 characters remaining

## Contact learnabout-electronics.org

Please use the contact form below if you have any comments, congratulations, cc

Do include an email contact address and we will always try to get back to you as soon as possible.  
\*(denotes required field)

First Name: \*

Last Name: \*

E-Mail Address: \*

E-Mail Address again: \*  
Please enter your E-mail Address a second time.

Organisation/School/College/ Company

Country

Message: \*

Hello,

My name is Niabelle Thelemaque and I am an electrical engineering student at the University of Central Florida. I am currently working on a senior design project, and for part of this project, I would like to reproduce some images from your website. I am writing to request permission to refer to these pictures in the technical document that I am working on.

Please get back to me at this email,

### Contact the Electronics Tutorials Team

We always encourage you to share your ideas and improvements with us, so if you have any questions about our [Electronics Tutorials](#) website, please feel free to contact us using the form below. Many thanks for your show of support.

Your Message (required)

My name is Niabelle Thelemaque and I am an electrical engineering student at the University of Central Florida. I am currently working on a senior design project, and for part of this project, I would like to reproduce some images from your Microelectronics Circuit Analysis and Design, 4th edition textbook. I am writing to request permission to refer to these pictures in the technical document that I am working on. The images I am primarily interested in images pertaining voltage regulators.

Please get back to me at this email, Niabelle\_Thelemaque@knights.ucf.edu or at (954) 850-0573.

Thank you for your help.

Sincerely,

Niabelle Thelemaque

## 10.3 Copyright Permissions

- Noun Project - Icons in Mobile Application and Logo (Creative commons License)
  - <https://thenounproject.com>
  - <https://creativecommons.org/licenses/by/3.0/us/>
- Adafruit Bluefruit LE
  - [https://github.com/adafruit/Bluefruit\\_LE\\_Connect\\_Android](https://github.com/adafruit/Bluefruit_LE_Connect_Android) (MIT)
  - The MIT License (MIT) Copyright (c) 2015 Adafruit Industries

Permission is hereby granted, free of charge, to any person obtaining a copy of this software and associated documentation files (the "Software"), to deal in the Software without restriction, including without limitation the rights to use, copy, modify, merge, publish, distribute, sublicense, and/or sell copies of the Software, and to permit persons to whom the Software is furnished to do so, subject to the following conditions:

The above copyright notice and this permission notice shall be included in all copies or substantial portions of the Software.

THE SOFTWARE IS PROVIDED "AS IS", WITHOUT WARRANTY OF ANY KIND, EXPRESS OR IMPLIED, INCLUDING BUT NOT LIMITED TO THE WARRANTIES OF MERCHANTABILITY, FITNESS FOR A PARTICULAR PURPOSE AND NONINFRINGEMENT. IN NO EVENT SHALL THE AUTHORS OR COPYRIGHT HOLDERS BE LIABLE FOR ANY CLAIM, DAMAGES OR OTHER LIABILITY, WHETHER IN AN ACTION OF CONTRACT, TORT OR OTHERWISE, ARISING FROM, OUT OF OR IN CONNECTION WITH THE SOFTWARE OR THE USE OR OTHER DEALINGS IN THE SOFTWARE.

- Ionic - Mobile Application
  - <http://drifty.com/>
  - MIT License

Permission is hereby granted, free of charge, to any person obtaining a copy of this software and associated documentation files (the "Software"), to deal in the Software without restriction, including without limitation the rights to use, copy, modify, merge, publish, distribute, sublicense, and/or sell copies of the Software, and to permit persons to whom the Software is furnished to do so, subject to the following conditions:

The above copyright notice and this permission notice shall be included in all copies or substantial portions of the Software.

THE SOFTWARE IS PROVIDED "AS IS", WITHOUT WARRANTY OF ANY KIND, EXPRESS OR IMPLIED, INCLUDING BUT NOT LIMITED TO THE WARRANTIES OF MERCHANTABILITY, FITNESS FOR A PARTICULAR PURPOSE AND

NONINFRINGEMENT. IN NO EVENT SHALL THE AUTHORS OR COPYRIGHT HOLDERS BE LIABLE FOR ANY CLAIM, DAMAGES OR OTHER LIABILITY, WHETHER IN AN ACTION OF CONTRACT, TORT OR OTHERWISE, ARISING FROM, OUT OF OR IN CONNECTION WITH THE SOFTWARE OR THE USE OR OTHER DEALINGS IN THE SOFTWARE.

### Microcontroller Libraries

Component	Site
Screen	<a href="https://learn.adafruit.com/monochrome-oled-breakouts/downloads">https://learn.adafruit.com/monochrome-oled-breakouts/downloads</a>
Accelerometer	<a href="https://learn.sparkfun.com/tutorials/lis3dh-hookup-guide">https://learn.sparkfun.com/tutorials/lis3dh-hookup-guide</a>
Bluetooth	<a href="https://learn.adafruit.com/introducing-the-adafruit-bluefruit-le-uart-friend/software">https://learn.adafruit.com/introducing-the-adafruit-bluefruit-le-uart-friend/software</a>
Pulse	<a href="https://www.dfrobot.com/wiki/index.php/Heart_Rate_Sensor_SKU:_SEN0203">https://www.dfrobot.com/wiki/index.php/Heart_Rate_Sensor_SKU:_SEN0203</a>
Microcontroller	<a href="http://playground.arduino.cc/Learning">http://playground.arduino.cc/Learning</a>
GPS	<a href="https://forum.arduino.cc/index.php?topic=381256.0">https://forum.arduino.cc/index.php?topic=381256.0</a> <a href="http://playground.arduino.cc/Tutorials/GPS">http://playground.arduino.cc/Tutorials/GPS</a>

### Mobile Application Libraries

Component	Site
Adafruit Bluetooth LE	<a href="https://github.com/adafruit/Bluefruit_LE_Connect_Android">https://github.com/adafruit/Bluefruit_LE_Connect_Android</a>
Android Developers	<a href="https://developer.android.com">https://developer.android.com</a>
Online Forums	<a href="https://stackoverflow.com">https://stackoverflow.com</a>
Android Studios	<a href="https://developer.android.com/studio/intro/index.html">https://developer.android.com/studio/intro/index.html</a>