

water wise

smart hydroponic system

The logo for 'water wise' features the words 'water wise' in a lowercase, rounded sans-serif font. The letter 'i' in 'wise' is replaced by a stylized plant stem with two leaves and a brain icon at the top. Below the main text, the tagline 'smart hydroponic system' is written in a smaller, lowercase sans-serif font.

Group #4

Joe Bender - CPE

Joseph Johnson IV - CPE

Akeem Liburd - EE

Matt LaRue - EE

Motivation

- Provide ability to grow plants in atypical environment
- Conserve water through continuous recirculation system
- Simplify hydroponic gardening through automation
- Promote healthy lifestyle with home grown greens

Goals & Objectives

- Provide real-time monitoring of environmental conditions
- Create a user-friendly experience via mobile application
- Construct a structure able to reside indoors or outdoors
- Develop an automated system for both entry-level and expert users

Specifications

Component	Parameter	Specification
Structure	Size	2.5' W x 3' L x 6' H
Environmental Sensors	Margin of Error	< 10%
Wireless Communication	Connectivity	WiFi
User Interface	Design	Material Design
Interaction	Mode	Physical Buttons or Mobile Application

Requirements For Success

User Must Be Able To:

- Control system using both LCD/buttons and mobile application
 - Toggle power to main system components
 - View recent sensor measurements of hydroponic ecosystem
- Download plant profile information for system

Hydroponics Introduction

- Growing plants in absence of soil
- Utilizes liquid nutrient solution
- Able to grow many varieties of plants
- Multiple system techniques
 - Aeroponics
 - Drip Technique
 - Nutrient Film Technique



Hydroponics - Nutrient Film Technique

Characteristics

- Growth tray tilted to utilize gravity
- Water oxidized with air pump
- Runoff drains into reservoir

Pros & Cons

- ✓ Efficient
- ✓ Possible with low power pumps
- ✓ Low maintenance
- ✗ Reliance on gravity increases height

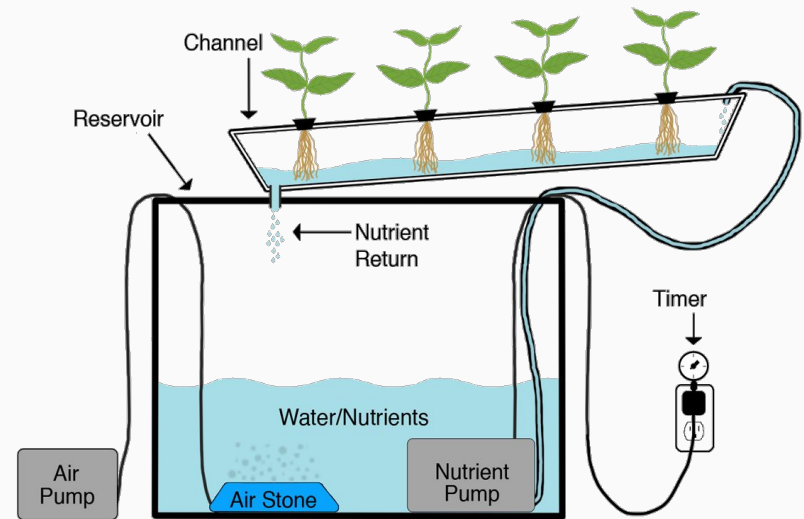

WaterWise Smart Hydroponic System

Structural Design:

- Cabinet
 - Water reservoir & submersible pump
 - Electrical components & sensors
 - PCB sealed in waterproof casing
 - Peristaltic pumps & nutrient hoppers
- Growth Canopy
 - Three growth channels
 - LED grow lights suspended above

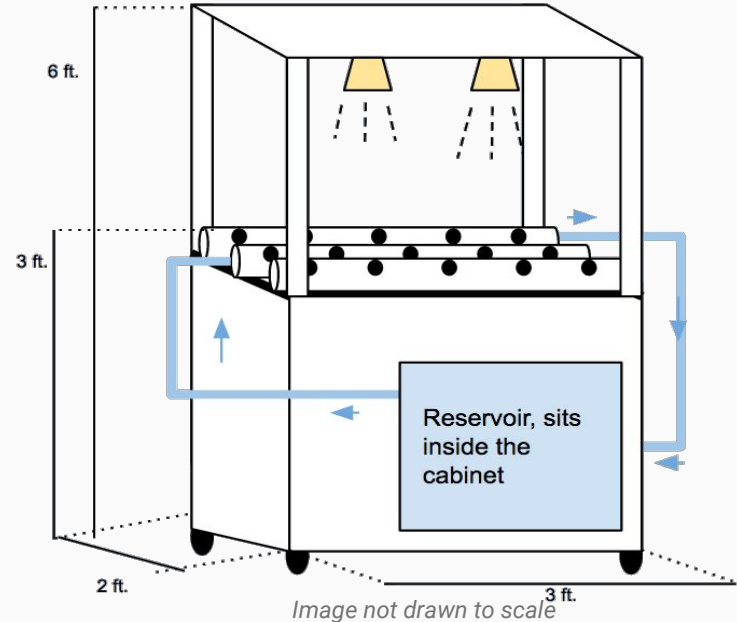

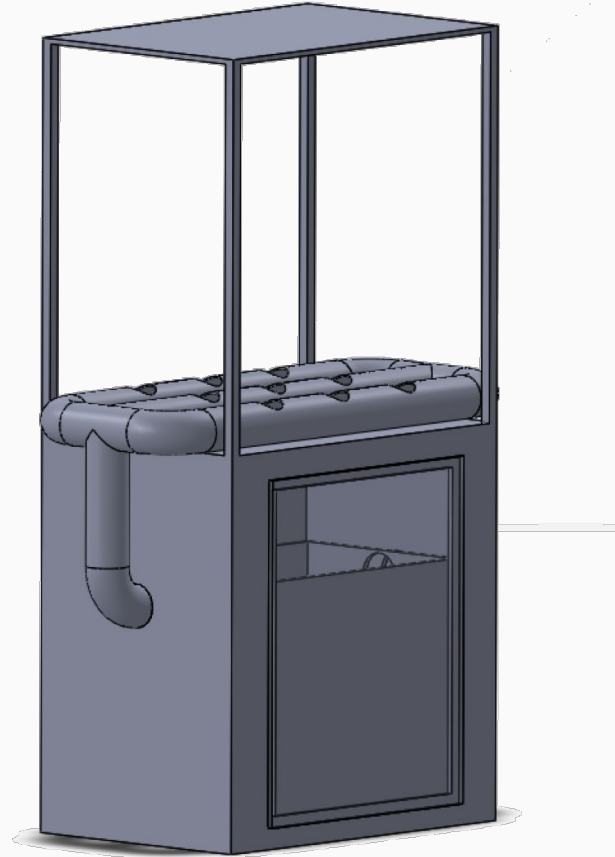

Overall Design

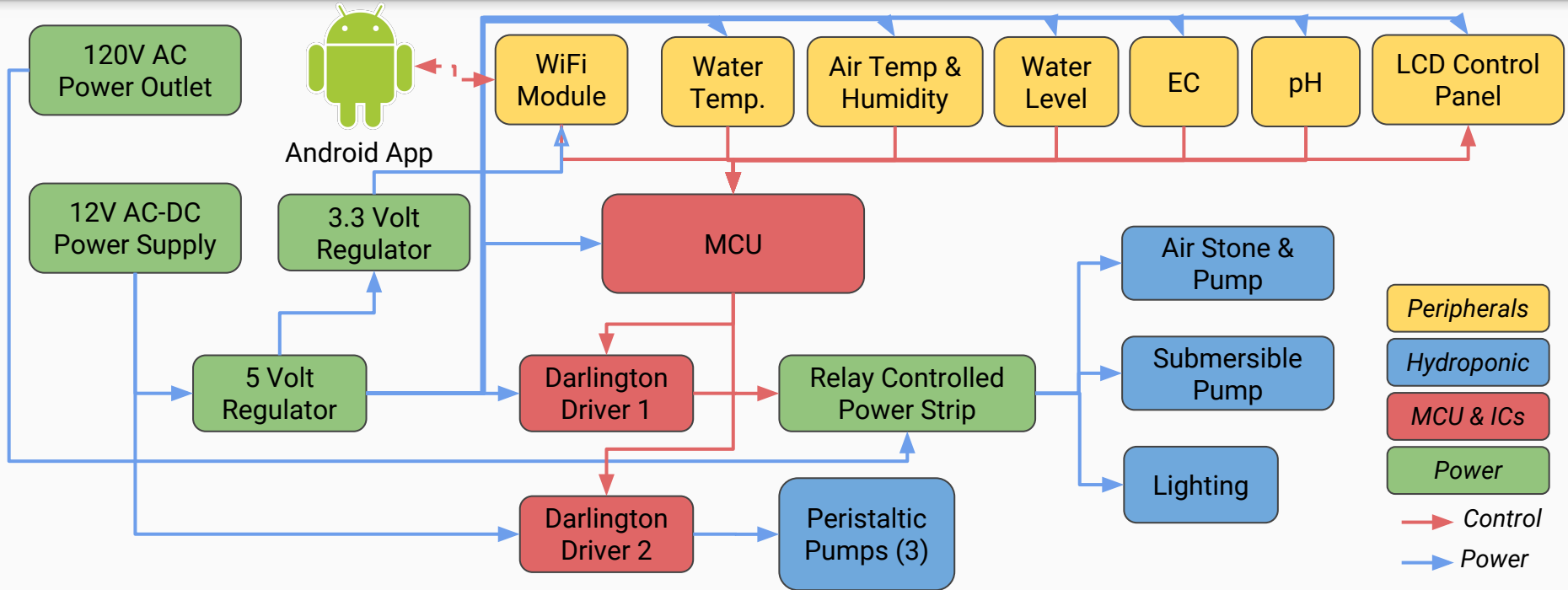

Power

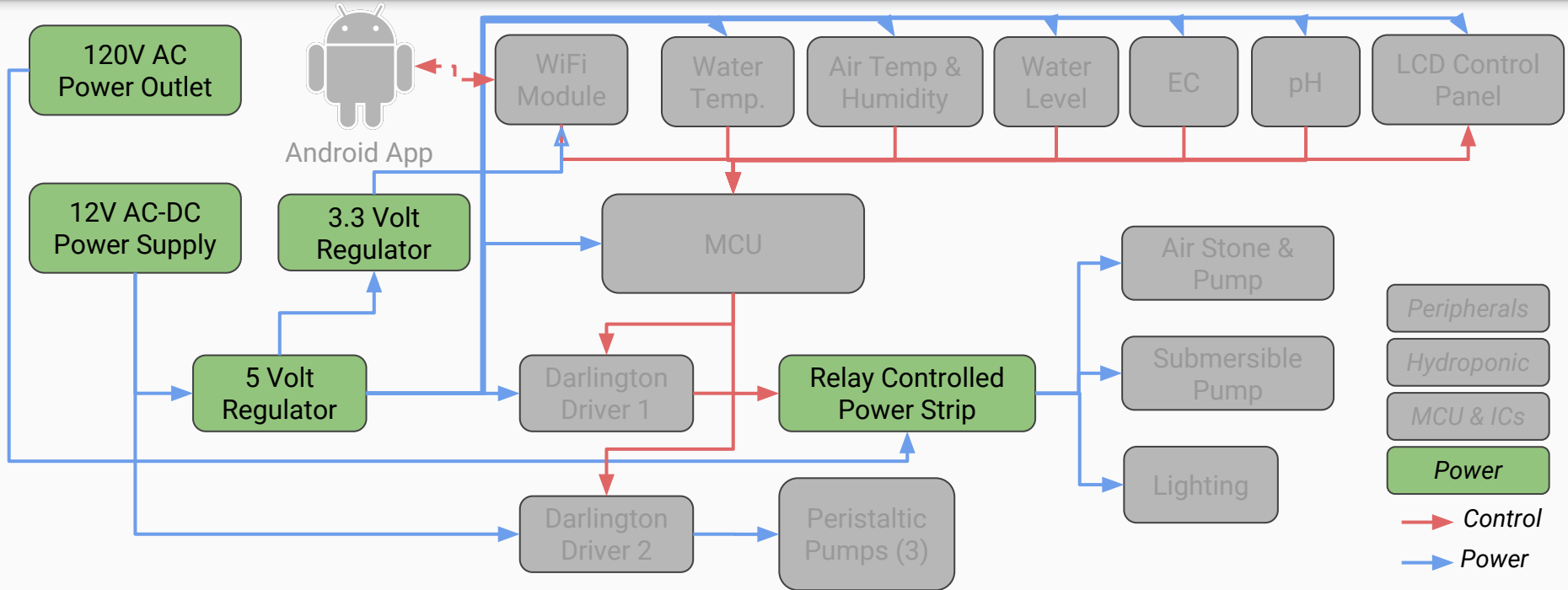

Power Supply Considerations

- Solar vs. No Solar
 - Needs to work indoors
- Battery Supply vs. 120V AC
 - Charging not user friendly
- Varying Subsystem Requirements
 - Some of them use 120V AC

PCB Power Supply

- PCB powered by 12V AC to DC converter with a standard 2.1mm barrel jack
 - PCB will use linear voltage regulators to obtain 5V and 3.3V



Relay Controlled Power Strip

- 4 *Grove Twig* relays control 4 power outlets
- 2 outlets remain always on

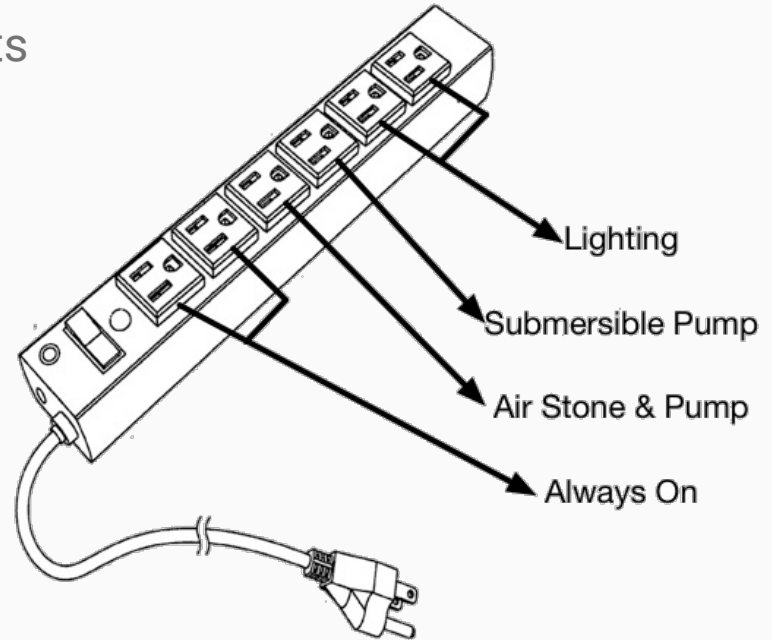
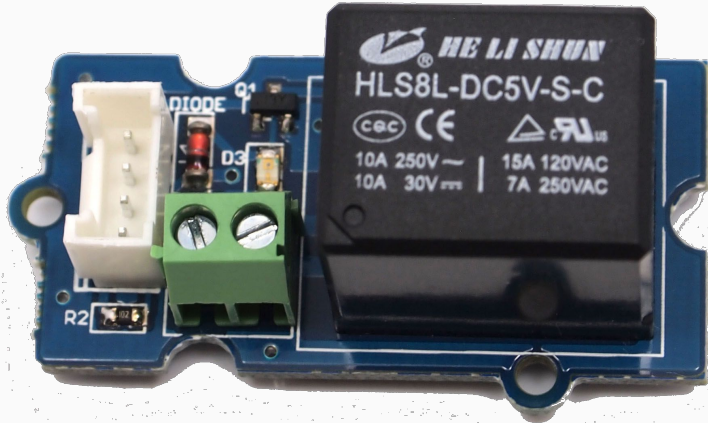

Relay Implementation Schematic

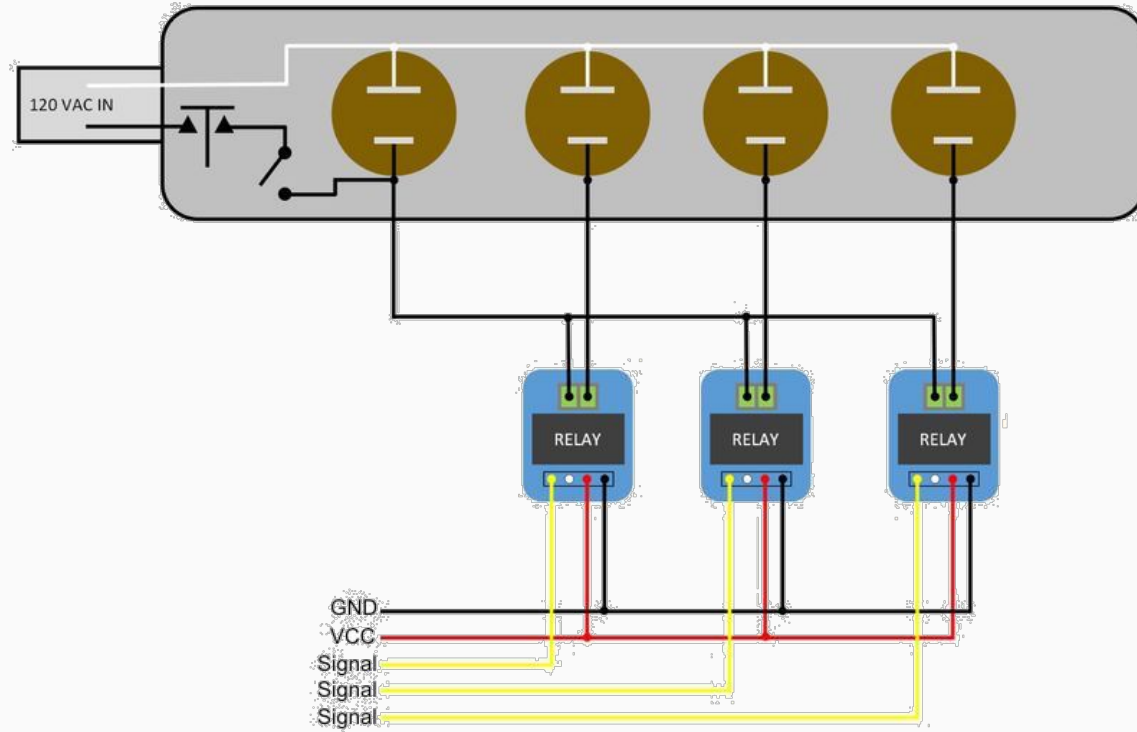

Microcontroller & ICs

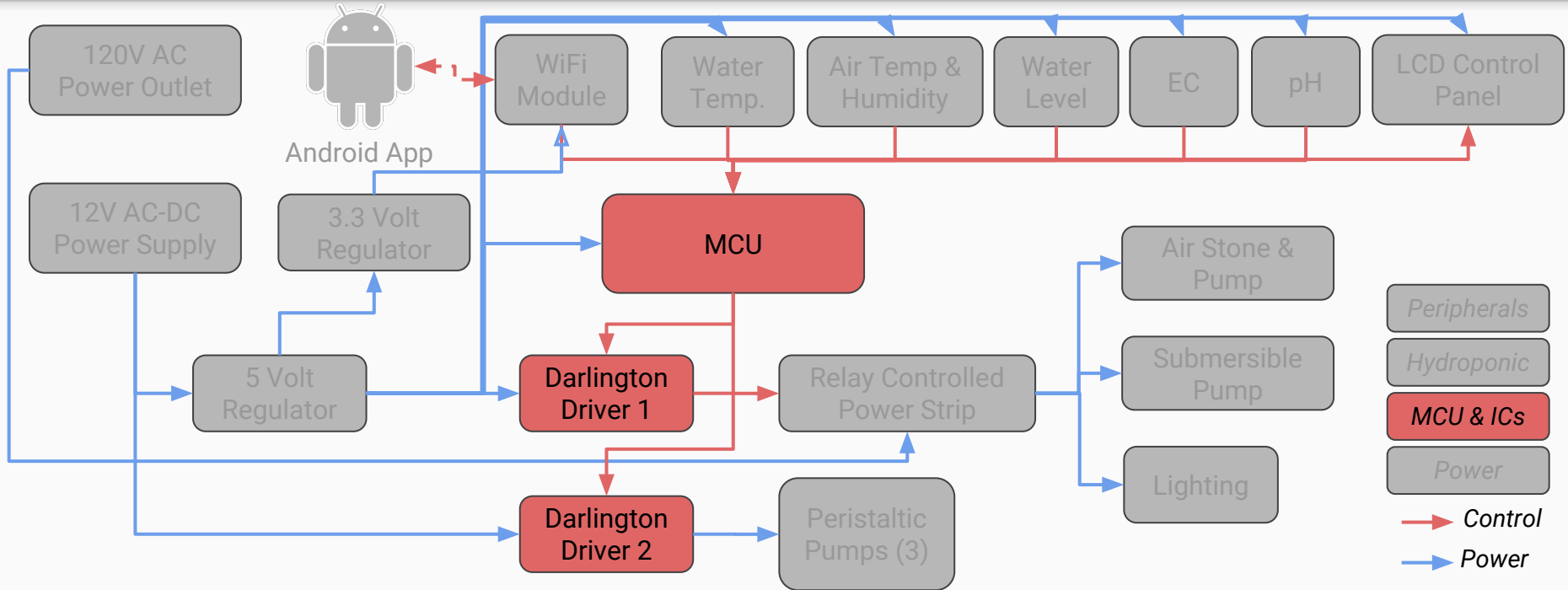

MCU Comparison

Specification	MSP430F6638	ATMega2560AU	ATMega328
Frequency	20 MHz	16 MHz	16 MHz
Non-Volatile Mem.	256 KB	256 KB	32 KB
Volatile Mem.	18 KB	8 KB	2 KB
Operating Voltage	1.8 - 3.6 V	5 V	5 V
General I/O Pins	74	86	23

MCU Comparison

Design Decision: ATmega2560AU

- Open source nature
- Abundant community resources
- Convenient operating voltage with peripherals

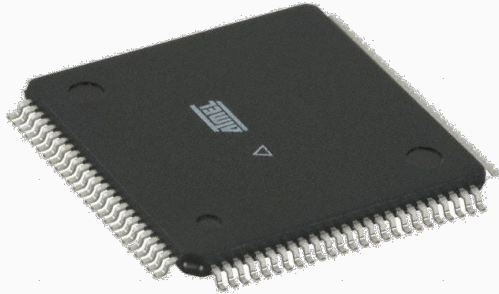

Specification	MSP430F6638	ATmega2560AU	ATmega328
Frequency	20 MHz	16 MHz	16 MHz
Non-Volatile Mem.	256 KB	256 KB	32 KB
Volatile Mem.	18 KB	8 KB	2 KB
Operating Voltage	1.8 - 3.6 V	5 V	5 V
General I/O Pins	74	86	23

Darlington Driver IC

ULN2803 Darlington Transistor Array:

- Used for driving relays and peristaltic pumps
- Prevents back-emf reaching MCU
- Output Current: 500 mA
- Max Output Voltage: 50 V
- Operating Voltage: 5 V

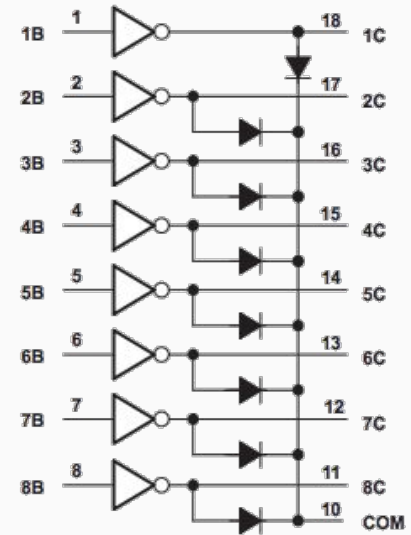

Courtesy of Texas Instruments

PCB Schematic Design

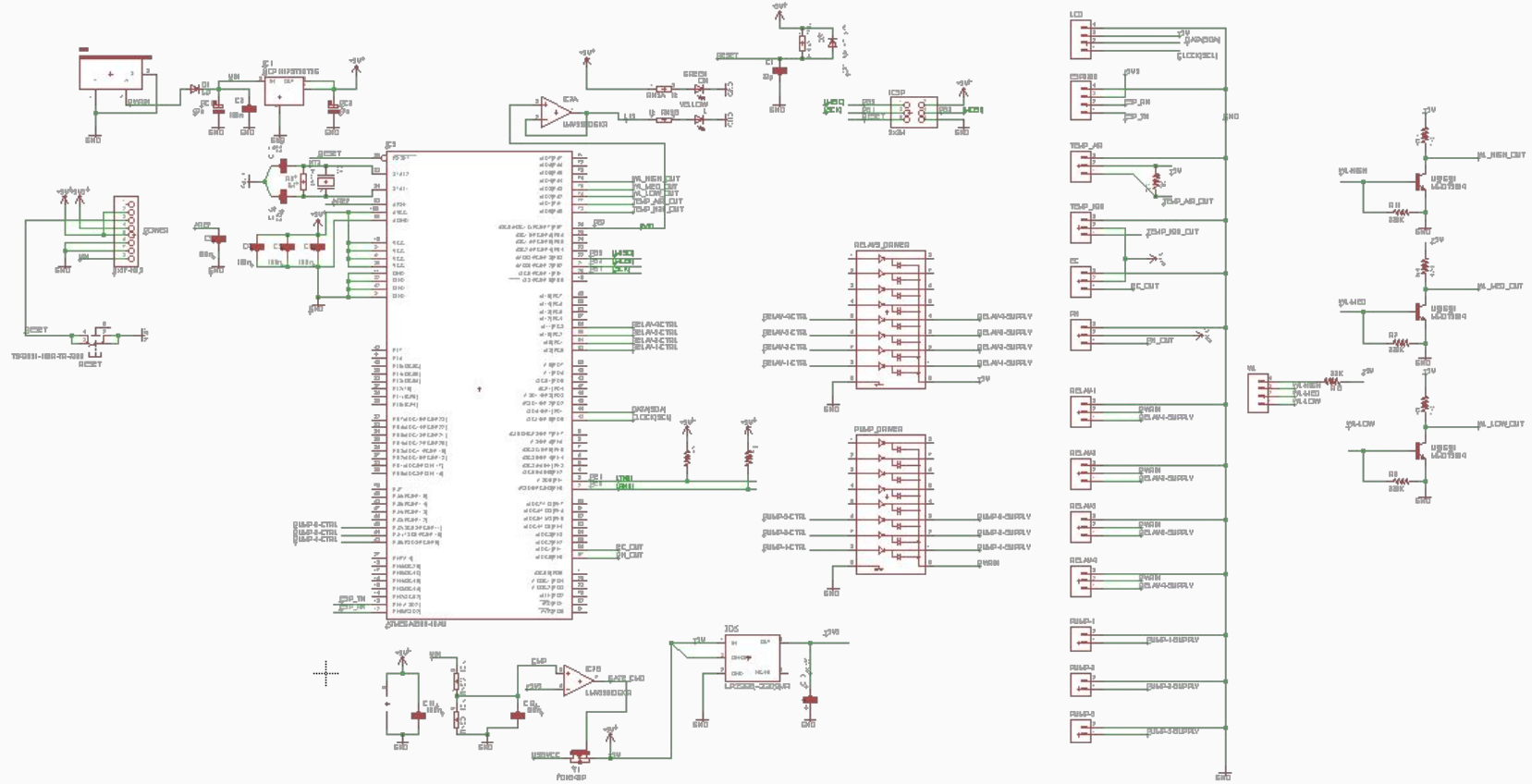

PCB Schematic - Power Distribution

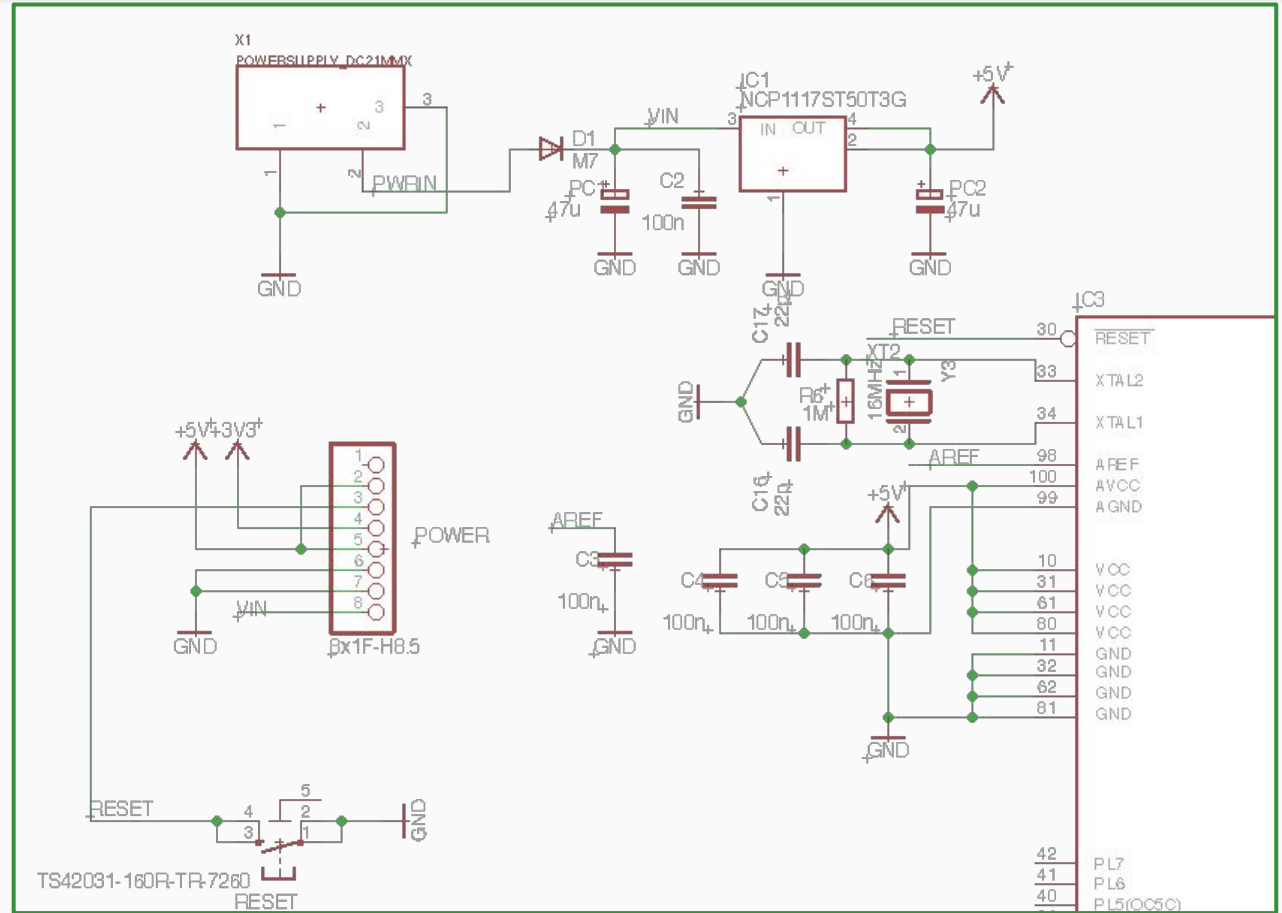
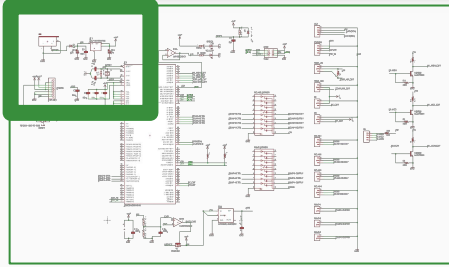

PCB Schematic - Sensor Interfaces

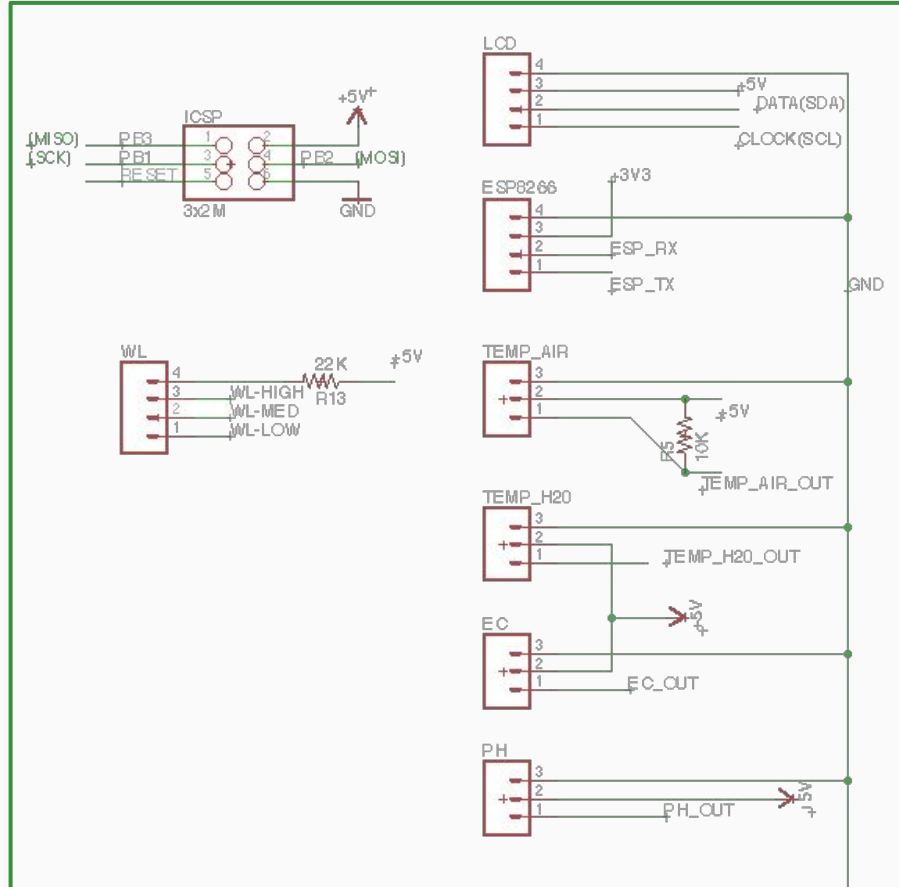
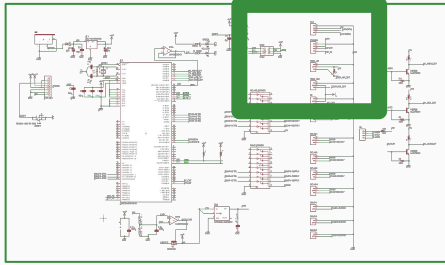

PCB Schematic - Darlington Drivers & Relay/Pump Interfaces

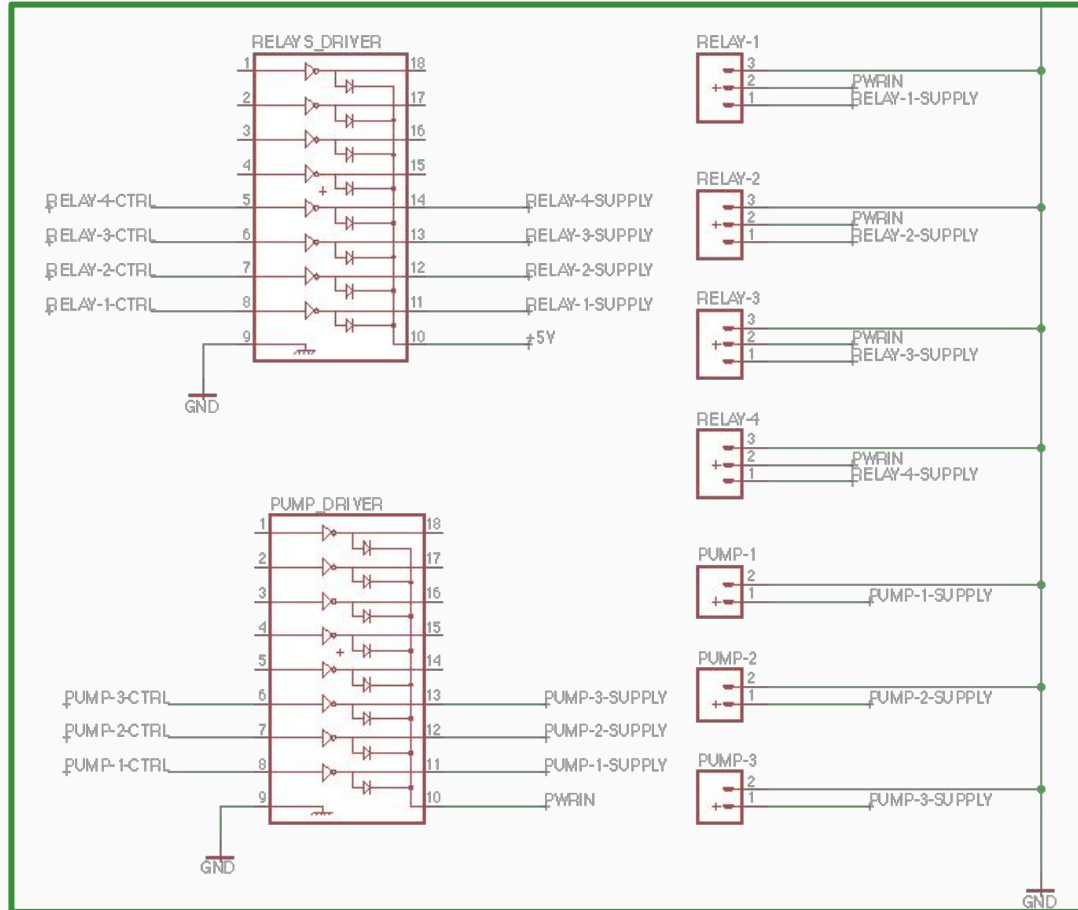
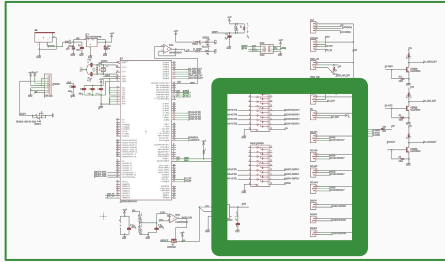

PCB Board Layout - First Attempt

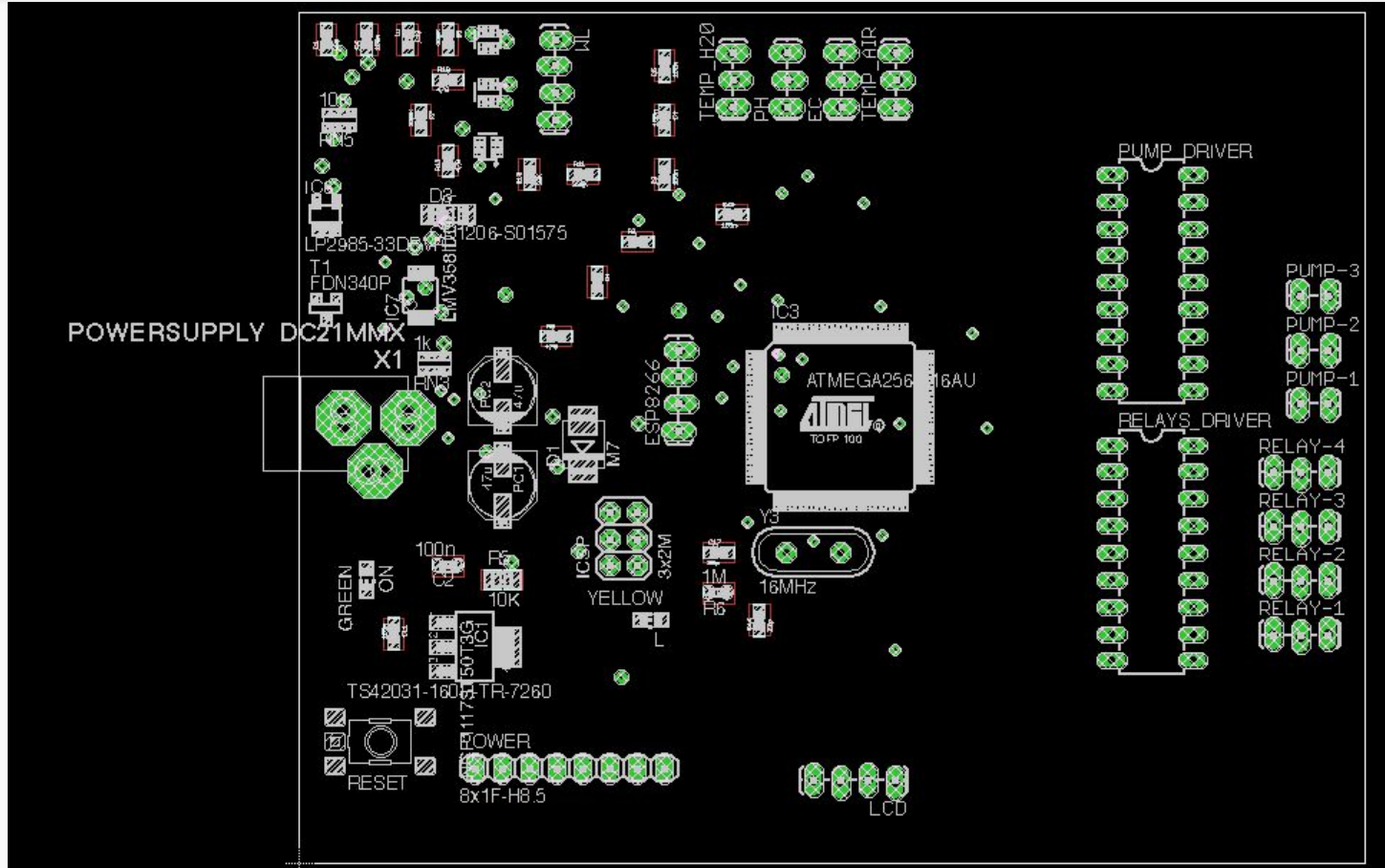

PCB Board Routes - First Attempt

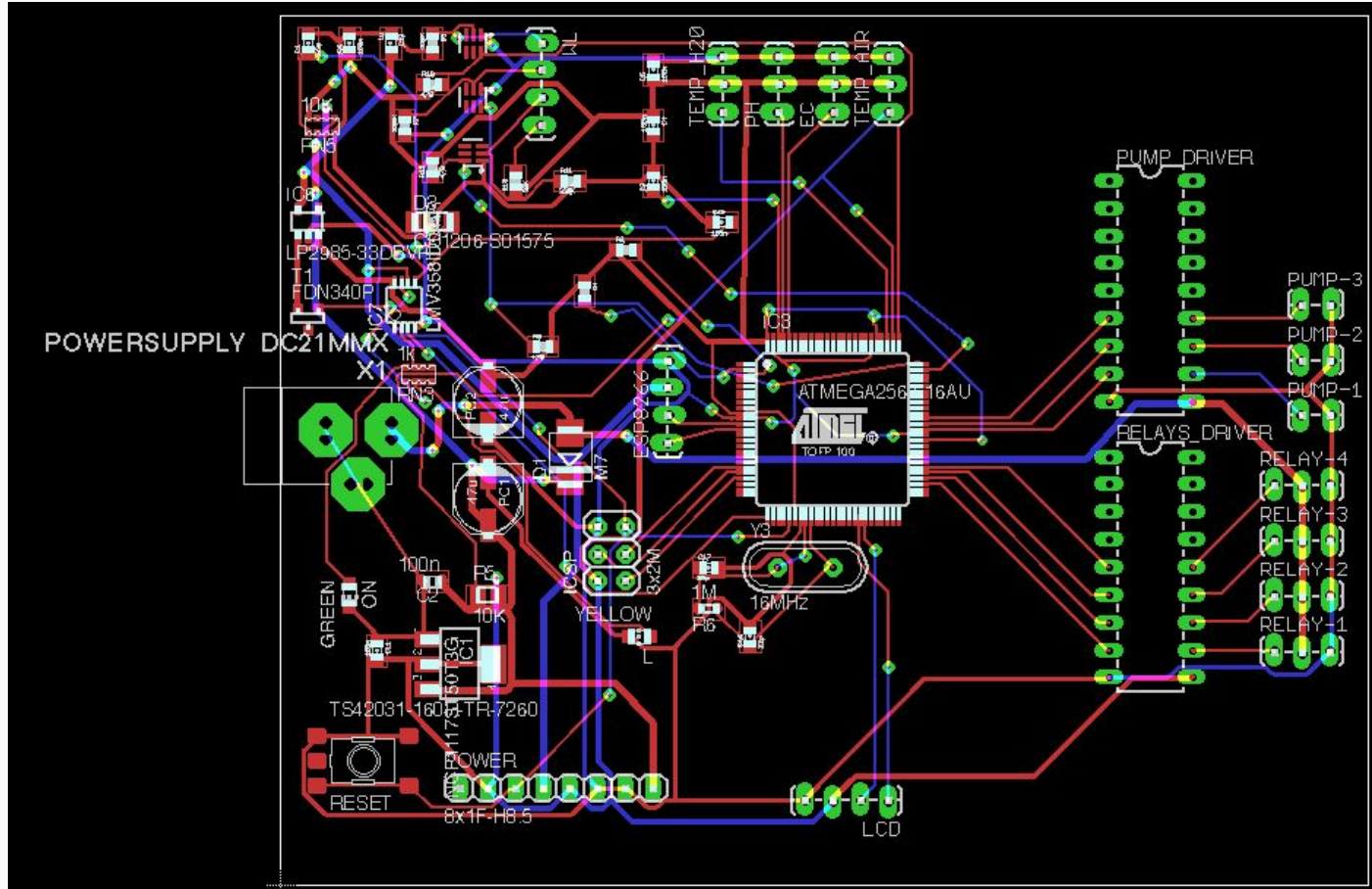

MCU Software Block Diagram

- MCU Input:
 - WiFi Module
 - Sensor Data
 - Control Panel Buttons
- MCU Output:
 - LCD Views
 - Sensor Alerts
 - Peristaltic Pumps
 - Power Relays
 - WiFi Module

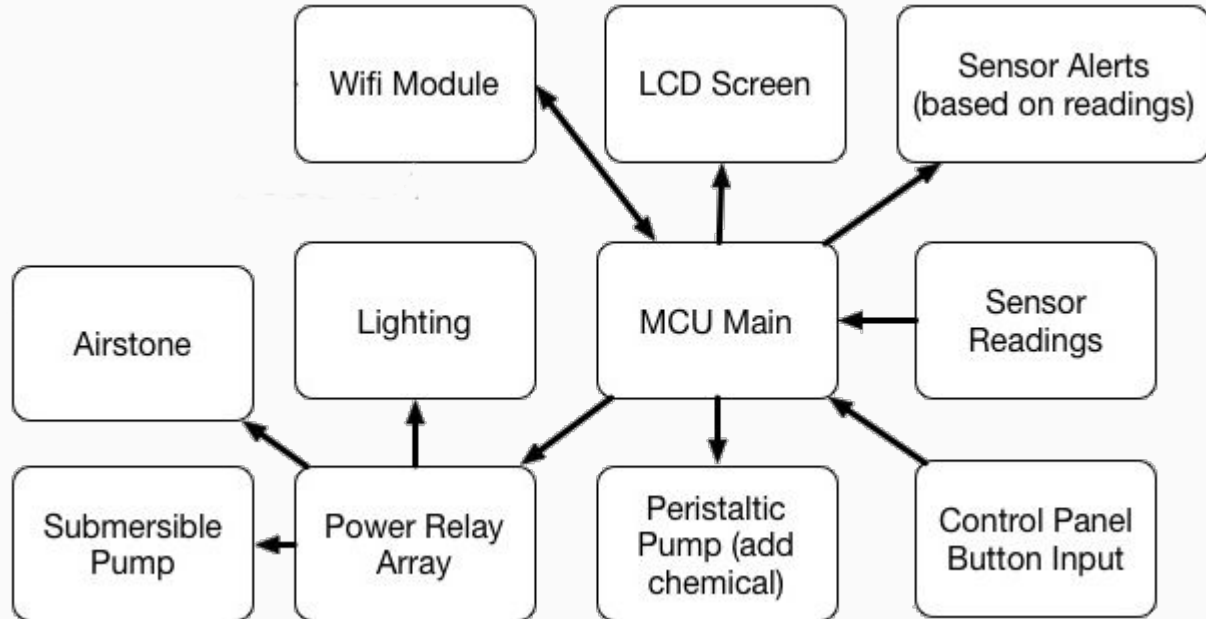

Peripherals

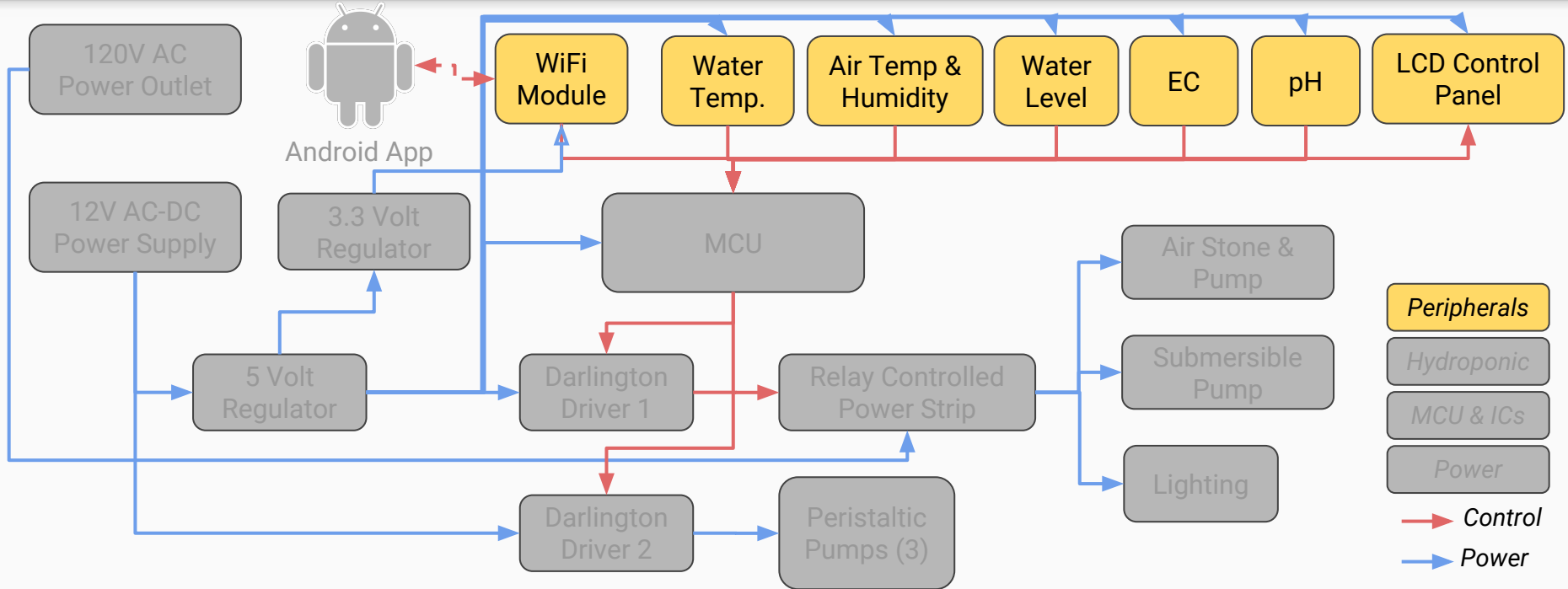

Wireless Communication

- **Bluetooth:** very short range, low connectivity
- **WiFi:** high data rate, good range, high power
- **ZigBee:** low power, good range & connectivity

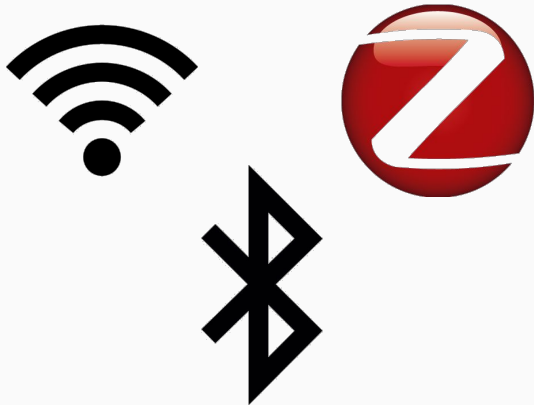

Standard	Bluetooth	WiFi	ZigBee
IEEE Spec.	802.15.1	802.11/n/ac	802.15.4
Data Rate	1 Mbps	54 Mbps	250 Kbps
Frequency	2.4 GHz	2.4 or 5 GHz	0.8, 0.9, 2.4 GHz
Range	10 m	up to 100 m	10 to 100 m
Power Supply	Days	Hours	Years
Net Topology	ad-hoc, very small networks	point to hub	ad-hoc, p2p, star or mesh
Device Impact	High	High	Low
Typical Applications	Wireless connectivity between devices	Wireless LAN connectivity, Internet access	Sensor networks, building automation, control and monitoring

Wireless Communication

- **Design Decision: WiFi**

- Good for Internet connectivity
- Usability in homes
- Abundant implementation resources

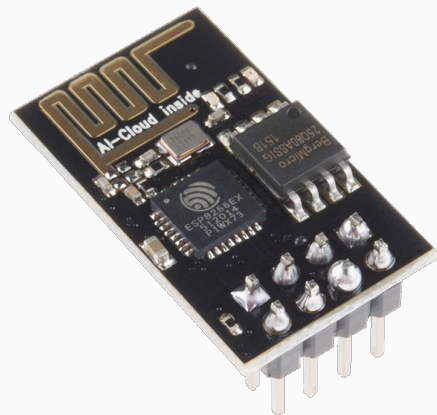

Standard	Bluetooth	WiFi	ZigBee
IEEE Spec.	802.15.1	802.11/n/ac	802.15.4
Data Rate	1 Mbps	54 Mbps	250 Kbps
Frequency	2.4 GHz	2.4 or 5 GHz	0.8, 0.9, 2.4 GHz
Range	10 m	up to 100 m	10 to 100 m
Power Supply	Days	Hours	Years
Net Topology	ad-hoc, very small networks	point to hub	ad-hoc, p2p, star or mesh
Device Impact	High	High	Low
Typical Applications	Wireless connectivity between devices	Wireless LAN connectivity, Internet access	Sensor networks, building automation, control and monitoring

ESP8266 WiFi Module

Features

- Two modes of operation
 - Wireless Access Point
 - Wireless Device
- Connects using a single TX and RX pin on the MCU
- Capable of hosting an HTML webpage

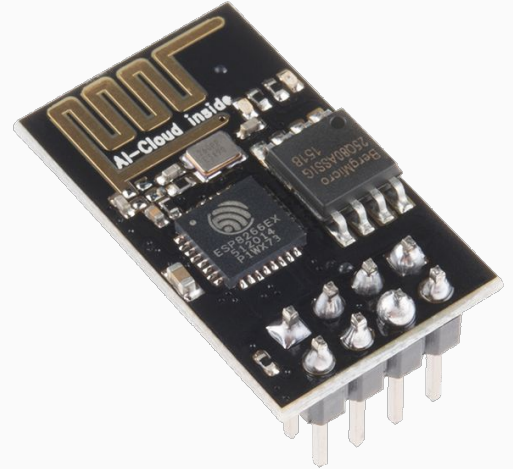

LCD Control Panel

LCD & Push Button Controls

- ✓ Low financial cost
- ✓ Simple to implement
- ✗ Lacks innovation
- ✗ Less user friendly



Touch Screen Interface

- ✓ Innovative design feature
- ✓ High design utility
- ✗ Difficult to implement
- ✗ Non-critical design component



LCD & Push Button Controls

- ✓ Low financial cost
- ✓ Simple to implement
- ✗ Lacks innovation
- ✗ Less user friendly



Touch Screen Interface

- ✓ Innovative design feature
- ✓ High design utility
- ✗ Difficult to implement
- ✗ Non-critical design component



LCD Control Views

- LCD and five-button control mounted to structure
- Able to power on/off and view sensor readings

LCD Control Views
16x2 Character Display & Up/Down/Left/Right/Select Buttons



Main Menu

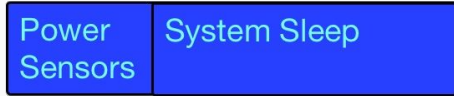

Power Menu



Sensor Menu

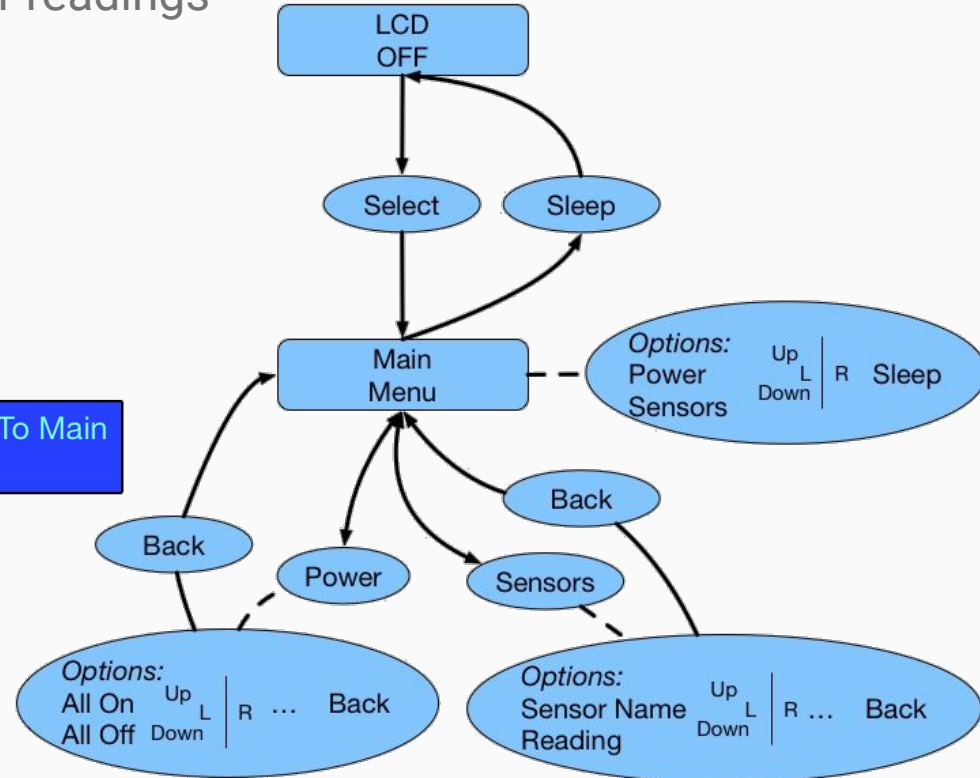

Electrical Conductivity (EC) Meter Kit

DF Robot EC Meter Specifications

Operating Voltage	+5.00 V
Operating Temperature	5 - 40 °C
Measuring Range	1mS/cm - 20mS/cm
Accuracy	<±10% F.S.
PCB Size	45 mm x 32 mm
Temperature Sensor	DS18B20 (Waterproof)

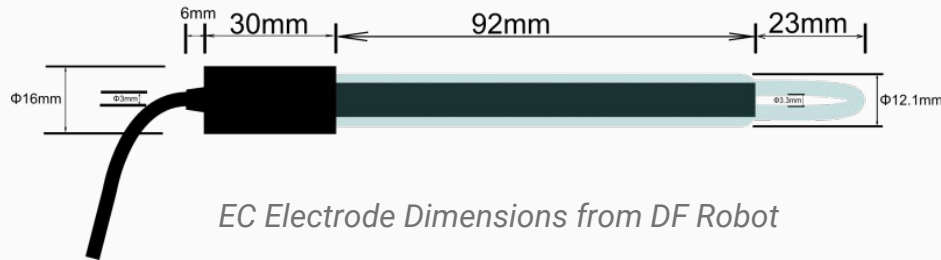

EC Electrode Dimensions from DF Robot

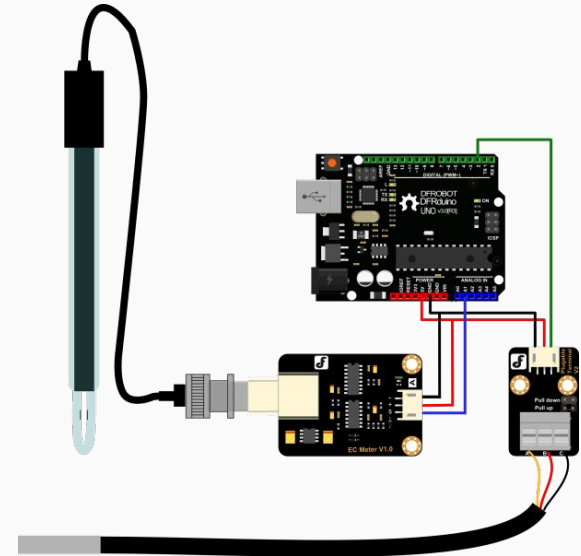

EC Meter Kit Connection Diagram with Temperature Sensor

Analog pH Meter Kit

DF Robot pH Meter Specifications

Operating Voltage	+5.00 V
Measuring Temperature	0 - 60 °C
pH Measuring Range	0 - 14
Accuracy	< ±0.1pH (25 °C)
PCB Size	45 mm x 32 mm
Response Time	≤ 1min

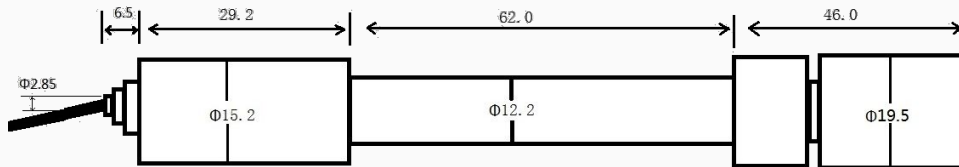

pH Electrode Dimensions from DF Robot

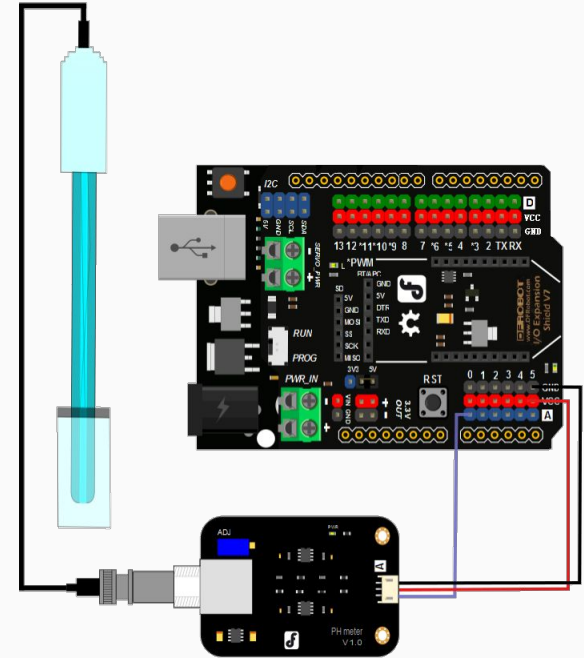

Analog pH Meter Connection Diagram

Air Temperature & Humidity

Analog DHT11 Specifications

Operating Voltage	3.00 - 5.50 V
Temperature Range	0 - 50 °C
Temperature Accuracy	±2°C
Humidity Range	20% - 90% RH
Humidity Accuracy	±4% RH
Temp Response Time	6s - 30s
Humidity Response Time	6s - 15s

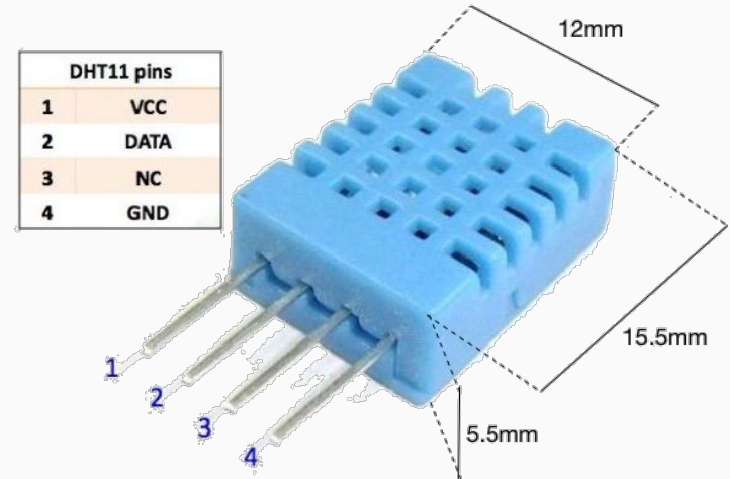

Analog DHT11 Dimensions and Pin Layout

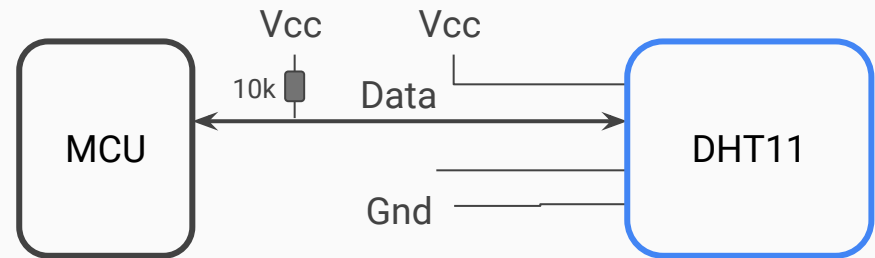

DHT11 Connection Diagram

Water Level Sensor

- Simple circuitry of jumper wire, resistors, and NPN transistors
- Operating Voltage: 5.00 V
- Realized by three digital probes
- MCU reads signals from different probes to indicate water level

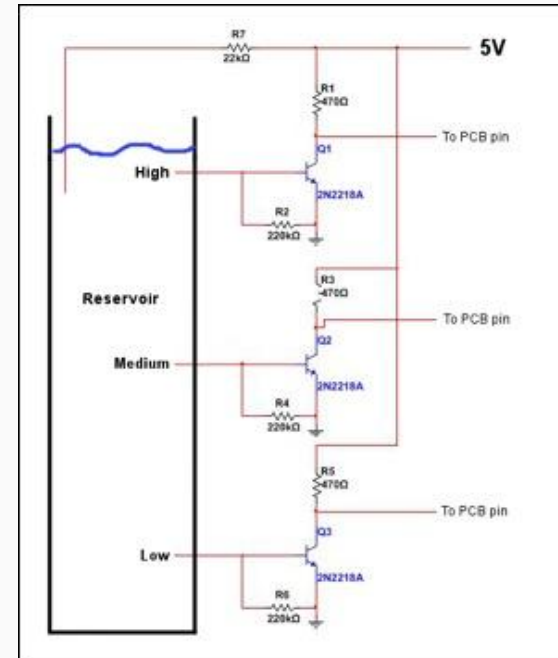

Hydroponic Components

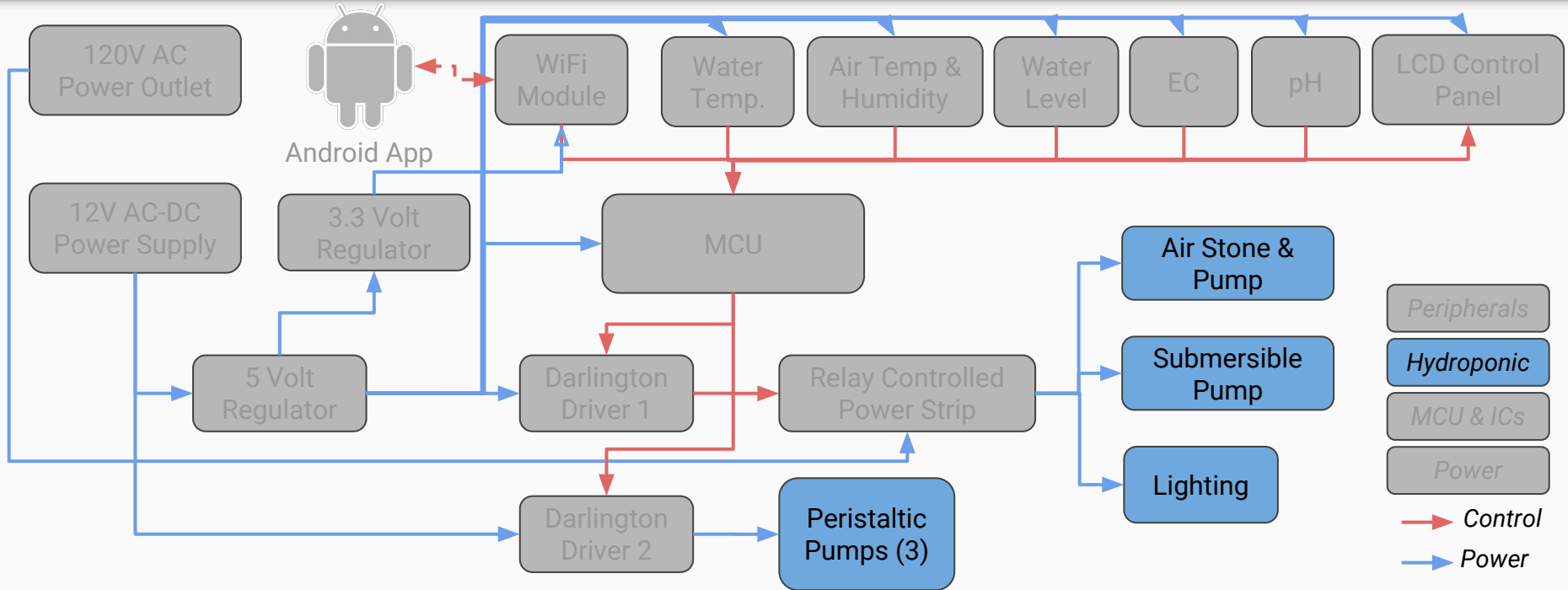

Submersible Pump

Active Aqua PW250

- Flow rate of 250 GPH
 - Much greater than needed for design.
 - Minimum flow rate of 87 GPH at head height of zero feet.
- Circulates system capacity once every two hours
- Versatile and relatively inexpensive



Lighting

HQRP Quad-Band 225 LED Grow Light

- (2) 12 in x 12 in x 1.5 in grow lights in canopy of structure.
 - Lights feature a proper balance of red, blue, and white LEDs for each stage of growth.

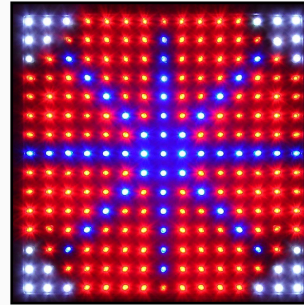

Color	Wavelength	Intensity	Number of LEDs
Red	660 nm	7.3 lux	77
Blue	450 nm	4.8 lux	47
Orange	630 nm	7.1 lux	77
White	n/a	7.5 lux	24

Air Disk & Pump

EcoPlus 728355 Air Pump

- 253 Gallons Per Hour
- 4 channel output

EcoPlus 728418 Airstone Disk

- Air Disk yields higher bubble output than air stone
- Combination yields higher dissolved oxygen levels



Nutrient Peristaltic Pump Array

Three Peristaltic Pumps

- pH up
- pH down
- Liquid nutrient
- Zero maintenance

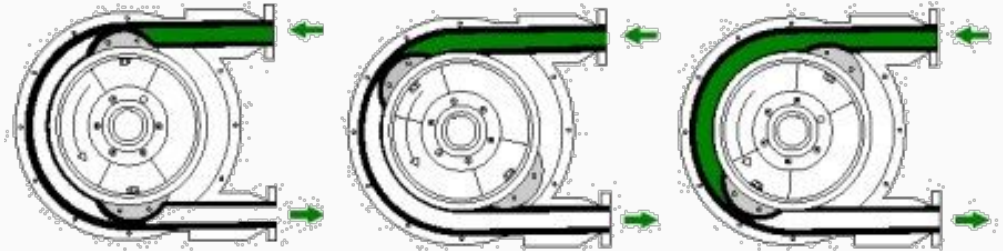

Mobile Application

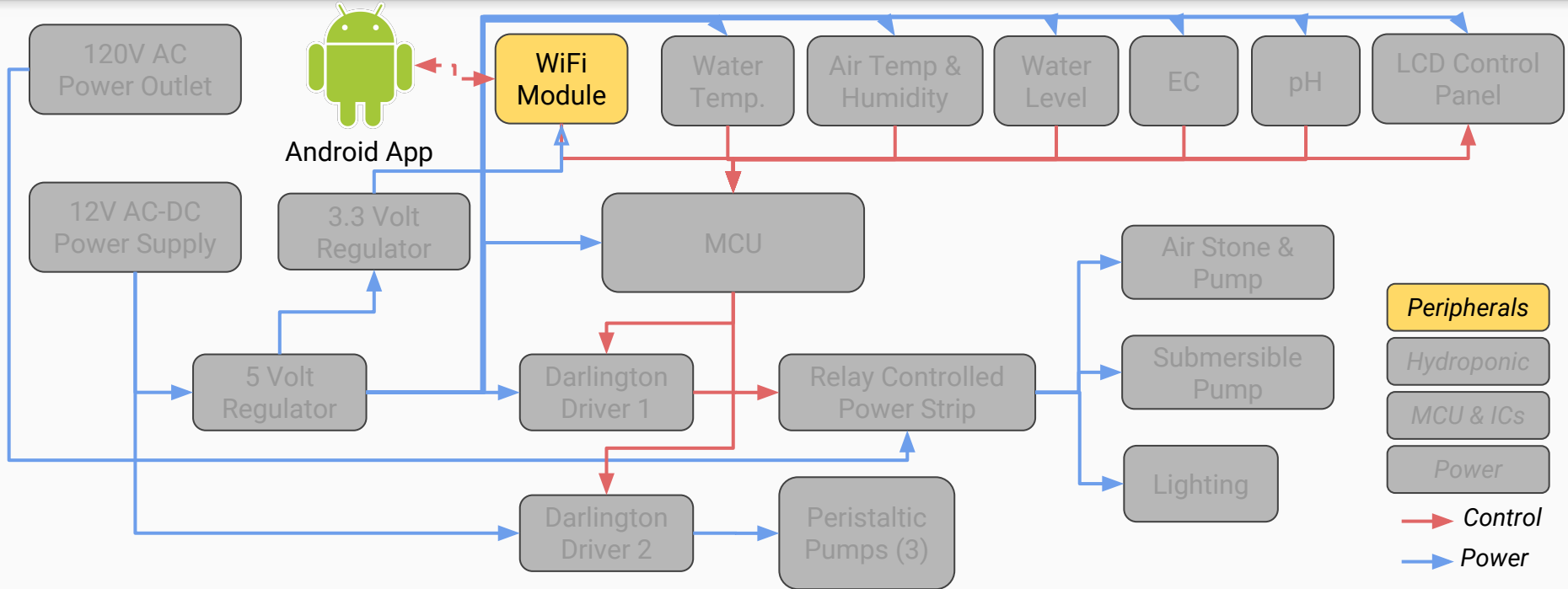

Platform Considerations

Android

- ✓ Largest market share
- ✓ Less expensive developer fees
- ✓ Application Side-loading
- ✓ Applications written in Java and XML

iOS

- ✗ Requires paid subscription
- ✗ Applications written in objective C or Swift

Windows Phone

- ✗ Very low market share
- ✗ Requires paid subscription
- ✗ Visual Basic or C#

Android Application Functionalities

User account system

- Create personal account for use with the mobile application
- Google+ log in
- Store application settings

System Interaction

- View sensor data
- Control power to subsystems
 - Pumps, lighting, etc.

Plant Database

- Database of plant growth information
- Search database and select a plant of interest to view growth information
- Assign currently growing plant to automatically configure nutrient pumps

Material Design

UX Design Language for Android

- Key principle of simplicity and usability
- Content lies upon Material
- Large emphasis on elevation and the use of shadows
 - Many elements are meant to be perceived as 'floating' above material
- Vibrant and distinctive color choices
 - Use contrasted colors to show where interaction is possible

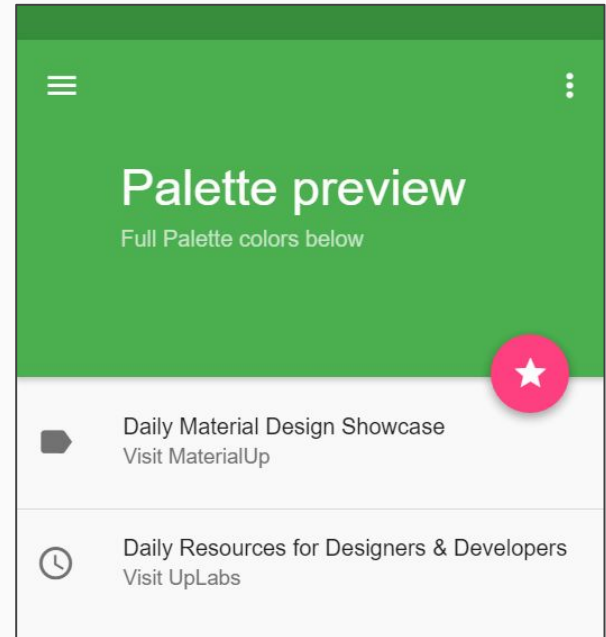

Prototype UI Design

- Simple user interface consistent with Material Design
- Floating action buttons to activate floating windows
- Hamburger menu icon consistent with Android ecosystem.

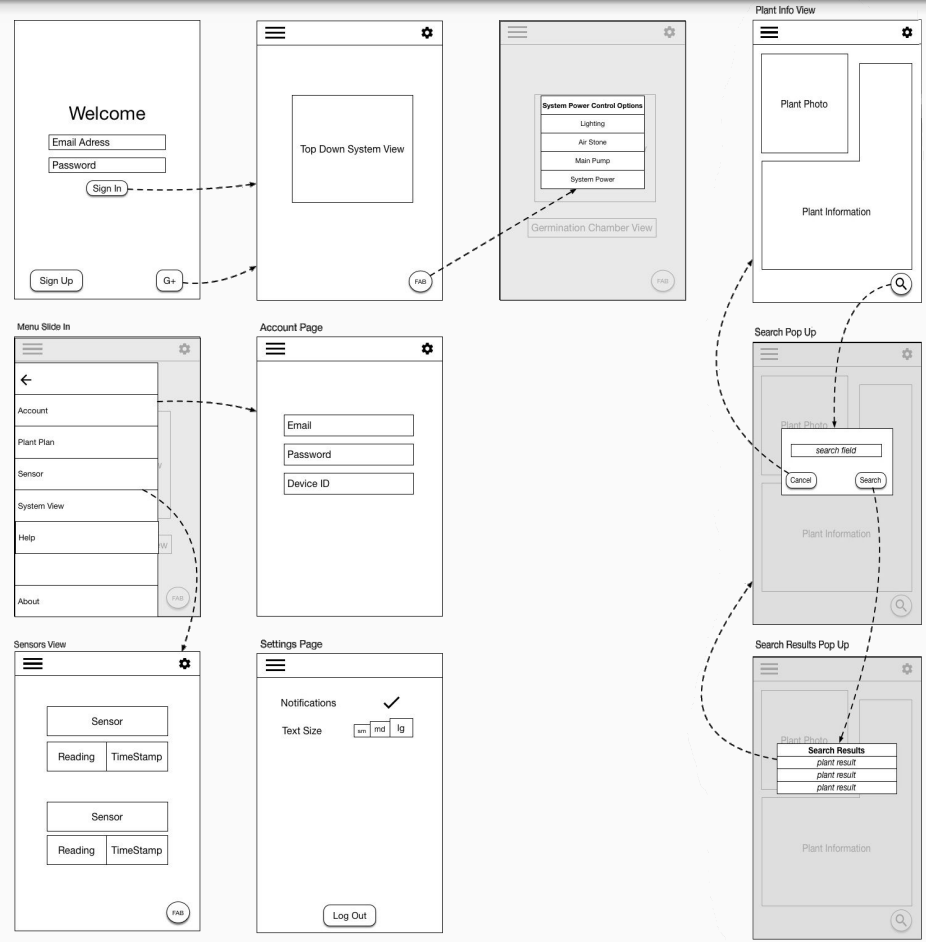

UI Screen Flow

- Number of application views: 6
- Number of floating menus: 2
- Persistent Slide in Menu

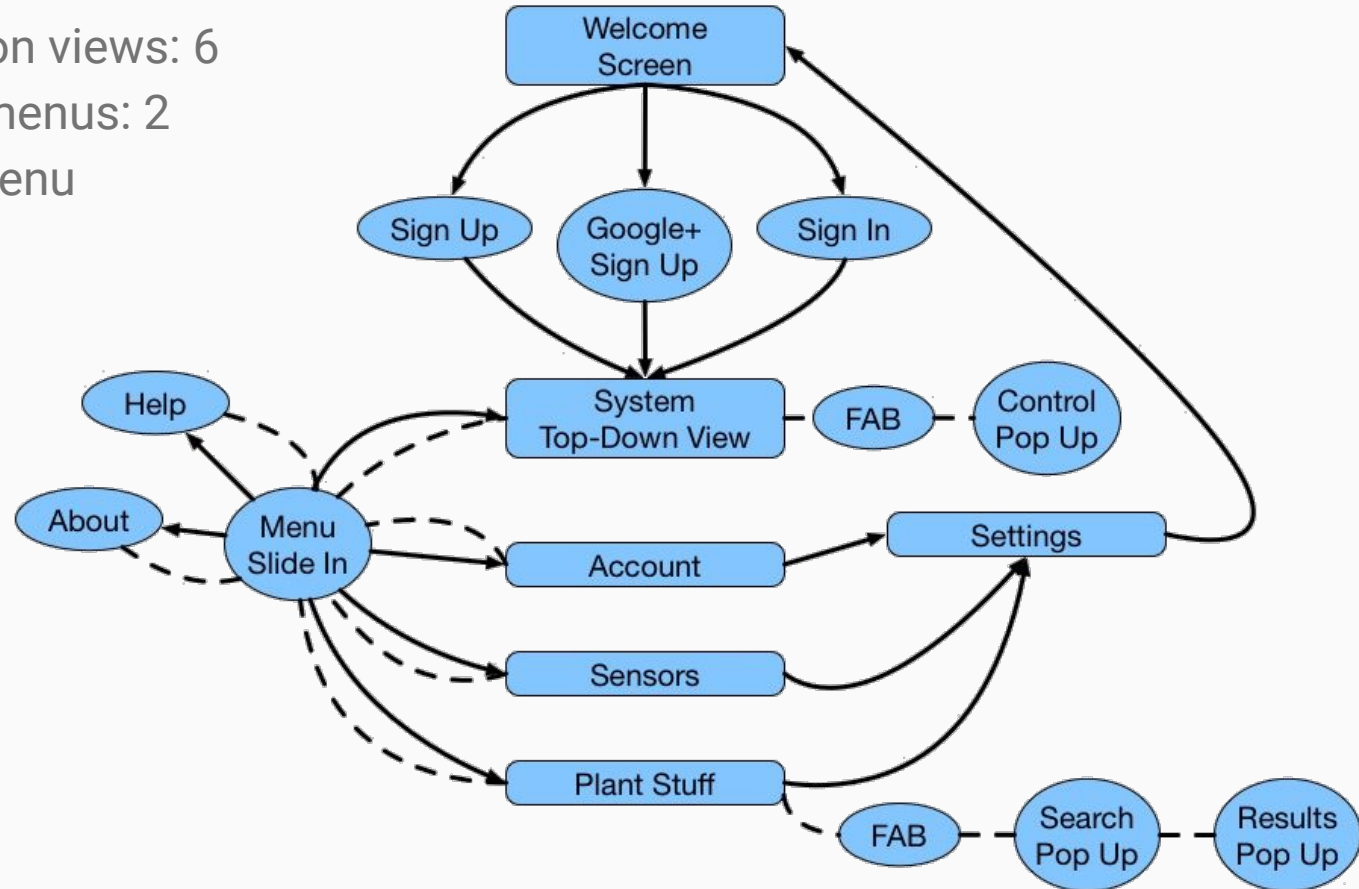

Kinvey MBaaS

Mobile Backend as a Service

- Saves development time
- Reduces liability
- Guarantees reliability
- Simple integration
- Easily scalable

Kinvey

- Popular MBaaS provider
- Multiple service tiers to fit our needs as they change
- Free tier for up to 1000 active users and 30GB of storage
- Simple API implementation for Android applications

WiFi Module Connectivity

Connecting the system

- Program wireless module to host simple HTML page
- Mobile application will instruct user to connect to AP hosted by wireless module
- Mobile application will provide link to HTML page
- User will input SSID and Password for desired wireless AP

Administrative Content

Budget Overview

#	Name	Vendor	Part #	Qty.	Price
1	Active Aqua Submersible Water Pump	HydroFarm	250 GPH – AAPW250	1	\$25.95
2	ATmega2560	Mouser Electronics	ATMEGA2560-16AU	1	\$16.54
3	Analog pH Meter Kit	DFRobot	SEN_ARDPH_D11	1	\$39.00
4	Basic Temp-Humidity Sensor	Adafruit	DHT11	1	\$5.00
5	Analog EC Meter	DFRobot	DFR0300	1	\$69.90
6	Workshop 6-Outlet Power Strip	Home Depot	0415518811	1	\$14.62
7	Peristaltic Pump	ZJchao	B00KJ5X1NY	3	\$12.59
8	LCD Control Panel	Adafruit	772	1	\$19.95
9	Super Sprouter Propagation Station	GrowersHouse	726400	1	\$37.83
10	ESP8266 Wifi Module	Mouser Electronics	485-2471	1	\$9.95

12	Heavy Duty Swivel Caster	HarborFreight	61758	4	\$7.49
13	253 GPH Air Pump	EcoPlus	728355	1	\$27.95
14	Ancor Watertight Wire Seal	Downwind Marine	765010	1	\$11.10
15	450w LED Grow Light Panel	Yescom	11GRL003-S225-BROWx2	1	\$49.95
16	Flexible Air Tubing	Penn-Plax	B0002563MW	1	\$4.45
17	Air stone	Hydrofarm	AS4RD	1	\$7.99
18	4" x 10' PVC	Home Depot	531103	1	\$21.87
19	Waterproof PCB Casing	Estone	B00JEWNKR0	1	\$5.19
20	12 VDC 2A Power Supply	All Electronics	PS-12275	1	\$6.50
21	Grove Relay	Seeed	103020005	4	\$2.90
22	3 in. Plastic Net Cup	1000Bulbs	HG3NETCUP	9	\$0.24
23	Kill A Watt Electricity Usage Monitor	P3	P4400	1	\$19.00

Total Cost: \$530.28

Financing

- Currently self-funding
- Proposals have been written and sent out for sponsorships; awaiting approval
 - Home Depot
 - Pentair Aquatic Ecosystems
 - Lockheed Martin

Work Distribution

Name	Akeem Liburd <i>EE</i>	Joseph Bender <i>CpE</i>	Joseph Johnson IV <i>CpE</i>	Matt LaRue <i>EE</i>
Power	Secondary			Primary
Mobile Application		Secondary	Primary	
Backend Integration			Primary	
PCB Design	Primary	Secondary		
Sensor Interfacing	Primary	Secondary		Secondary
MCU Software		Primary	Secondary	
Physical Structure		Secondary		Primary
Hydroponic Design	Secondary		Primary	Secondary

Primary

Secondary

Progress

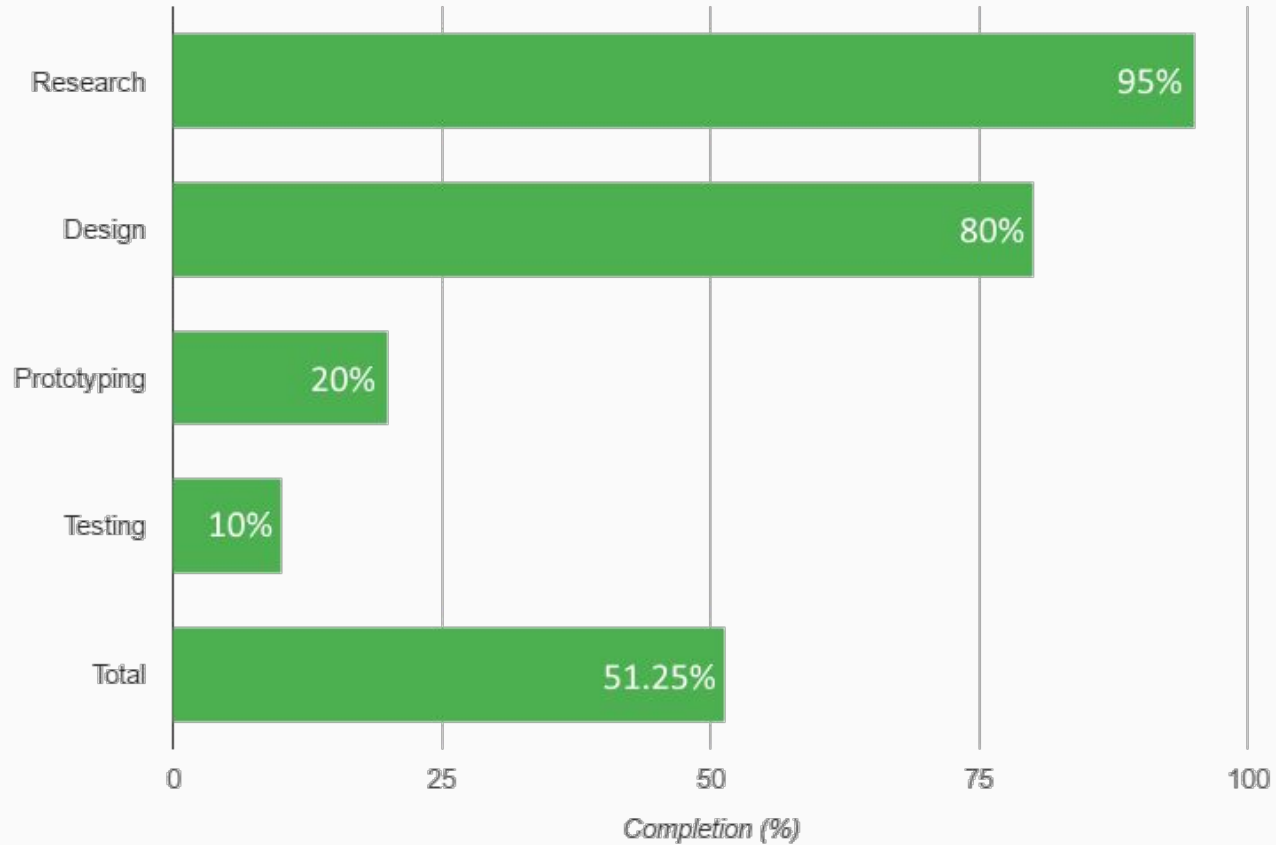

Questions?