

Senior Design Project

Final Document

~\*\*\*~

Solar Powered Intelligent Bike Rack System



Team Member: The Pham | Christine Erwin | Nha Nguyen | Daniel Adarme

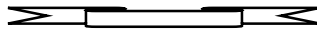

UNIVERSITY OF CENTRAL FLORIDA

# CONTENTS

1. Executive Summary.....	1
2. Project Description.....	2
2.1. Project Motivation.....	2
2.2. Goals & Objectives.....	3
2.3. Specifications and Requirements.....	3
3. Research Related to Project Definition.....	5
3.1. Existing Products or Projects.....	5
3.1.1. Citibike.....	6
3.1.2. Juice Orlando.....	6
3.2. Demand Analysis.....	7
4. Standards.....	8
4.1. DC/AC Conversion.....	8
4.2. Solar Panels.....	8
4.3. Security Camera.....	9
4.4. Battery Storage.....	9
4.5. Wireless.....	11
4.6. Magnetic Card.....	11
4.7. RFID.....	14
5. Realistic Design Constraints.....	14
5.1. Physical.....	14
5.2. Time.....	15
5.3. Economic.....	15
5.4. Environment & Safety.....	16
6. Research.....	17
6.1. Charge Controller.....	17
6.1.1. Pulse Width Modulation.....	17
6.1.2. Maximum Power Point Tracking & Options.....	19
6.2. Battery Storage.....	21
6.2.1. Backup System.....	21
6.2.1.1. Lead-Acid Battery.....	21
6.2.1.2. Battery Performance vs Temperature.....	23
6.3. Photovoltaic System.....	25
6.3.1. Grid-Connected.....	25
6.3.2. Off-Grid (Stand-Alone) Solar Power System.....	26
6.3.3. Size.....	26
6.3.4. 12 Volt System.....	27
6.3.5. 24 Volt System.....	27
6.3.6. Solar Cell Technology.....	28
6.3.6.1. Crystalline.....	28
6.3.6.2. Thin Film.....	29
6.3.7. Wiring Configuration.....	31
6.3.7.1. Parallel.....	31
6.3.7.2. Series.....	32
6.3.7.3. Combination.....	31
6.3.8. Wire and Connector Components.....	32

6.3.8.1.	American Wire Gauge PV.....	33
6.4.	Locking Mechanism.....	34
6.5.	Power Distribution System.....	37
6.5.1.	Power Converters.....	37
6.6.	Security Camera System.....	38
6.6.1.	Webcamera.....	38
6.6.2.	Raspberry Pi Camera.....	38
6.7.	Light Sensing Technology.....	39
6.7.1.	Phototransistors.....	39
6.7.2.	Photodiode.....	39
6.8.	Bicycle Identification System.....	40
6.9.	User Interface.....	41
6.9.1.	Cost.....	41
6.9.2.	Size and Connectivity.....	41
6.9.3.	User Authentication.....	42
6.9.4.	Display Screen.....	43
6.10.	Wireless Communication.....	45
6.10.1.	WiFi.....	45
6.10.2.	Bluetooth.....	46
6.10.3.	RFID/NFC.....	46
6.11.	Embedded Systems.....	47
6.11.1.	Central System.....	47
6.11.2.	Light & Camera System.....	48
6.11.3.	Time Keeping Methods.....	49
6.11.4.	Motion Sensor.....	49
6.12.	Software Development Environments.....	50
6.13.	Cloud Solutions.....	51
7.	Project Design Details.....	52
7.1.	Overview Block Diagram.....	52
7.2.	Structural Design.....	53
7.3.	Hardware Design.....	54
7.3.1.	Power System.....	54
7.3.1.1.	Charge Controller.....	55
7.3.1.2.	Power Stage.....	57
7.3.1.3.	Logic Control.....	59
7.3.1.4.	Bias Power Supply.....	59
7.3.1.5.	Power Distribution.....	59
7.3.2.	Solar Panels.....	66
7.3.3.	Power Distribution System.....	68
7.3.3.1.	DC-DC Inverter.....	68
7.3.3.2.	DC-AC Inverter.....	69
7.3.3.3.	Circuit Protection and Snubber.....	79
7.3.4.	Security System.....	79
7.3.4.1.	Security Camera.....	79
7.3.4.2.	Memory Storage.....	80
7.3.4.3.	Lighting System.....	80

7.3.4.4.	Microcontroller.....	80
7.3.4.5.	Motion Sensor.....	80
7.3.5.	Lock System.....	87
7.3.6.	Embedded System.....	89
7.3.7.	RFID and Magnetic Card Reader.....	89
7.4.	Software Design Details.....	90
7.4.1.	User Interface.....	90
7.4.1.1.	LCD Screen.....	90
7.4.2.	Security Camera Embedded System.....	96
7.4.3.	Lighting System Embedded System.....	97
7.4.4.	MPPT Software Structure Design and Programming Language	98
8.	Project Implementation.....	100
8.1.	Parts and Acquisition and BOM.....	100
8.2.	Facilities and Equipment.....	101
8.3.	Hardware Implementation.....	101
8.3.1.	Power System.....	101
8.3.1.1.	Charge Controller.....	101
8.3.1.2.	DC-DC Converter.....	101
8.3.1.3.	DC-AC Converter.....	102
8.3.2.	Security System.....	103
8.3.3.	Lighting System.....	103
8.3.4.	RFID and Magnetic Card.....	103
8.4.	Software Implementation.....	103
9.	Prototype Testing.....	104
9.1.	Hardware Testing.....	104
9.1.1.	MPPT Charge Controller Testing.....	105
9.1.2.	Data Reading Program (Graphical User Interface GUI PMP7605)	105
9.1.3.	Connection between the Hardware and the GUI .....	106
9.1.4.	Graphical User Interface Data Reading.....	106
9.1.5.	Efficiency Test for the Charge Controller.....	107
9.1.6.	DC-DC Converter Testing.....	109
9.1.7.	TICC3200 Hardware Interface Testing.....	112
9.1.8.	Lighting and Security Camera Testing.....	114
9.1.9.	DC-to-AC Converter Testing.....	117
9.1.10.	Locking Mechanism Testing.....	118
9.2.	Software Specification Testing.....	118
9.2.1.	Software Testing Environment.....	118
10.	Maintenance.....	122
10.1.	Locking Mechanism.....	122
10.2.	Power Distribution.....	122
11.	Troubleshooting.....	123
12.	Administrative Content.....	124
12.1.	Legalities.....	124
12.2.	Senior 1 Milestone.....	125
12.3.	Senior 2 Milestone.....	126

12.4.	Budget.....	127
13.	Appendices.....	128
13.1.	Appendix A – Permission.....	128
13.2.	Appendix B – Reference.....	129

# 1. Executive Summary

In recent years, more and more students are using a bicycle as their main transportation to campus because of numerous benefits it offers. Firstly, by using a bike to go to school, it can help students from being stuck in crowded traffic. Secondly, riding a bike to school assists in preventing environmental pollution. However, there are few problems that bike owners usually have to deal with daily and those problems can become significant if they're not addressed seriously. One of the first reasons why students are afraid to use their bikes to go to class is that their bikes can get damaged due to many external factors such as harshness of weather (raining), colliding with other bikes, etc. A bike is not an inexpensive thing to buy, and it can become extremely costly to the bike rider if it is not maintained properly. The first problem we identify is a proper bike storage place for a bike owner. Another factor that can become a major issue is the security and convenience for the bike owners. Whoever owns a bike would be concerned more about the issue of bike theft. Even with the advancement of modern bike lock technology, bicycle theft rates are still at a significant level. In an article regarding bike theft "the article link is in the reference section", it is stated that the number of the bikes being stolen nearly reached to 200,000 bikes across the US in 2008 according to the Federal Bureau of Investigation. Therefore, students who own a bike, and use it frequently, risk exposing their bikes, and themselves, to this unfortunate event.

KnightRyder Station will be the solution to all these problems. The main goal of this project is to help to solve the problems that the students who own bikes currently have to deal with every day when it comes to storage place, security, and convenience. In addition, with a few add-on features being designed and installed on the system, it will surely provide many great benefits to the bike owners.

The KnightRyder Station is a new concept for bike storage system. The bike rack will be fully covered by a roof where the solar power will be mounted on top of it. The purpose of having the roof cover for the bike rack is to protect the bike, and to have a strong foundation that can support the solar panel system. The solar power will be the main power supply to the whole bike rack system, and it is an off-grid type so the whole system can be installed at any desired place. The main purpose for the idea of choosing an off-grid type over the tie-to-grid type solar system is to be easily relocated and installed. The lock system for the bike rack is designed specifically for security and convenience purposes. First, it is designed to be accessible for all types of bike. With a careful design plan, our lock system will not only fit to all bikes but also provides better security. All the locks will be controlled mainly by the microcontroller and it have the ID card reader feature, which means only students who have valid school ID can have access to the locks. This provides the most convenient and secure way for students to store their bikes. In addition to our bike rack lock system, we also have some great add-on features to provide for bike owners such as the AC power outlet charging station where students can charge their bikes while they are in class, the LED strip lighting system with a smart sensor that will turn on the lights when it's dark outside, and the security camera with

motion detector feature that will record when there is a moving object near the system. All of these features are designed thoroughly to maximize the security for bike owners.

Another problem is seen, not by the users, but by UCF itself. After the end of semesters, students are in a hurry to travel back home and many times they leave their bikes locked to a rack. During the down time, UCF begins to put notices on the bikes for the owners when they return. However, due to unforeseen events the owners do not return and UCF is stuck with the problem of a locked bike taking up room, preventing other students of using the space. KnightRyder Station provides the correct solution, as the system will know who the bike belongs to, hence the purpose of swiping the UCF ID. This way, during term breaks, the system (or a crew member) can access the database and notify the owner that his/her bike is still on the racks. If the bike is left unattended, UCF can take custody of the bike, removing it from the rack (freeing space) and notifying the owner of when and where they can pick up their bike.

One more concept that we have recently added to our system is the bike rental service. The bike rental service is created based on the interests and high demands from students. We acknowledge that students find it inconvenient to travel between classroom buildings with a short time gap between. The result for this inconvenience is being late to class which is not fair for students. Therefore, the idea of the bike rental service is created to be the solution for these inconvenient problems. Every student with valid school ID will have full access to this service. After swiping their ID to the system, students will be provided with different time range options for their bike rental. Students must return the bike back to the station before the time runs out. In the case that the bike is returned after the time runs out, the system will send the data of the person who rented the bike to the school system.

The objective for this project is to apply our knowledge and experiences in electrical engineering studies to solve real world problem. We want to plan, design, and engineer a product that not only delivers a better solution to the problems presented, but also brings the benefit to the users. From an electrical engineering perspective, we want to build our own circuit systems in the most cost effective way, yet maximize the performance. In addition to a cost effective strategy, we also want to design an energy efficient project. Our system involves renewable energy technology as the main power supply and designed with a low-power device technology.

---

## **2. Project Description**

The following section will outline the motivation for the project, the specifications and requirements that will be set, but subject to change if necessary, as guidelines for the build process for the project to follow. We will also define the goals and objectives for researching and implementing the project.

## **2.1. Project Motivation**

When discussing the idea for this project, we all wanted to something that would challenge ourselves and be meaningful at the same time. We wanted to be able to implement several subsystems and assign roles that played to each individual's strengths. After much deliberation, we came to the conclusion that improving the bike rack by incorporating electronics was the way to go. We deemed this idea as useful, since it could easily be applied to UCF's campus, since so many students ride their bikes as their main mode of transportation. We also see it as a way to foster the use of clean transportation. We think that by improving upon the security of the bike rack, we can diminish the fear that people have of their bikes being stolen, thus increasing the willingness for people to ride their bikes to school.

By implementing solar panels and an electric bike charging station, we hope to even further support clean energy. It is important for us to think of the impact we have on the environment on a daily basis, and how we can go about making a positive impact, and this project is a way too. We hope that this project, no matter how small, will have a positive effect by letting more people safely use clean transportation. Among all of these motivations, the concepts of transforming our lives into clean energy and finding the best way to harness these renewable energy source are the primary key for this project to happen. Another important factor that motivate us to make project happening is about the people, the community. All of people around us, friends, family, teacher, have been supporting us and putting their trust in us. This is why we want to invest everything we have into this project, to make this project into a reality.

## **2.2. Goals & Objective**

The goal of this project is to have a fully functional bike rack system. Looking at the specifics though, we want to be able to implement several subsystems that are intended to improve upon current bike rack models, especially the security of them. We want to implement a bike rental system, where each bike is equipped with a mode of identification. We also want to be able to have people store their personal bikes, including electric bikes. We want the electric bike user to be able to charge their bike at the rack. All bikes will be secured behind locks that will be locked and unlocked by a form of identification. This is only one form of security however. We will improve where other bike racks fail by making a secure as possible lock, but will also add a security camera into the system to aid as a theft deterrent. In addition, the bike rack will be lit up in the dark so that user may see and feel safe and secure. Ultimately, we want the bike rack to be powered mainly by solar power, with batteries for backup.

## **2.3. Specifications and Requirements**



<b>Power Specifications</b>	
<b>#</b>	<b>Description</b>
1	The project will be energy sufficient through solar panels that will be implemented on top of a roof.
2	There will be batteries (3) for backup. The reason for this is for AC charging capabilities, night-time operations and possible power shortage from the panels.
3	The charge distribution will be controlled by one charge controller that will direct the distribution of power from the solar panels to the batteries and to the MCUs, LCD screen, and magnetic locking system.
4	There will be a light sensor to detect insufficient daylight.
5	One DC-to-AC converter for AC charging capabilities. This is for promoting green energy as electric bikes are more affordable for college students.
6	The roof will double as a shelter for the bike(s).

<b>UI Specifications</b>	
<b>#</b>	<b>Description</b>
1	Low-power system that will remain awake for only a few minutes.
2	The main MCU will drive the LCD screen, sub MCU and card reader.
3	A second MCU will be used for the lock mechanisms
4	There will be a magnetic card reader which will authenticate UCF Students. If person is not a UCF student, they must swipe a credit card.
5	The LCD screen should be optimal for outdoor use with daylight.
6	When a student completes the process of authentication, the bike should be unlocked for a short amount of time to the user.
7	Identification (unknown implementation) tags will be placed on the bikes for identification purposes for the system. This is effective when renting the bikes out.
8	Identification tags will enable proper data logging for usage purposes.
9	The system should provide convenient interaction with the user.
10	All corresponding data will be driven to a cloud-based server where student authentication will take place and correct data logging for pick-up/drop off.

<b>Security Specifications</b>	
<b>#</b>	<b>Description</b>
1	There will be a low-power security system which will be activated with a motion sensor.
2	The security camera will be an LPM system, running for only 10 minutes at a time when motion is detected.
3	The footage from the cameras will be stored on an external hard drive and will be extracted and cleared in corresponding intervals.
4	The docking station along with RFID tags will be an additional theft-deterrent specification.
5	Electronically controlled mechanical locking mechanisms will secure bikes.

Table 1 – Specifications and Requirements

---

### 3. Research Related to Project Definition

The following section will overview the related projects or systems that are in existence today and could be used as a basis model for this project. It will also overview a short demand analysis for the UCF campus to possibly implement this system.

#### 3.1. Existing Products or Projects

Bike-sharing systems have been growing linearly\* all over the globe in the past decade. Countries in Europe, such as Denmark, France, Germany, England and Spain have highly successful bike-sharing systems. Hangzhou, China has one of the largest bike-sharing networks in the world.\* their reputations and popularity amongst climate-change enthusiasts have heightened the awareness to others seeking viable clean transportation. Their effectiveness is within close range distances, where the need to take a taxi or an autobus can be easily replaced by a bicycle. Alongside the climate benefit is also the health benefit an individual receives by mobilizing themselves from point-to-point.



Figure 3.1 - Hangzhou bike system which supports over 60,000 bikes.

Bike-sharing is nothing new. The first recorded bike-sharing system occurred in 1960's Amsterdam. The program was relatively simple, white-painted bikes were used and dropped wherever for someone else next to use it. The program collapsed quickly as bicycles quickly vanished and/or ended up in Amsterdam famous canals. It wasn't until 2005 when a French program named Velo'v in Lyon, France marked the first successful large-scale bike sharing system.

Successful bike-sharing systems design vary from city to city, however they all have a few commonalities among them. These are theft deterrent, dense network, simple UI, wireless tracking systems, and balance cost to user. The theft deterrent comes in the

design of securing the bicycle itself and the vulnerabilities of the hardware/software system. A dense network of bicycles is essential to success. A lack of density hurts the perception of the effectiveness of bike sharing and may deter potential cyclers. A simple UI eliminates the requirement to be technologically savvy in order to operate the system and creates an optimal the user experience. Wireless tracking systems are required in order to keep proper inventory and login/logout times of users. A balanced cost to the user assists in maximizing short term use and reflects the competitions of non-renewable energy, such as busses and taxis.

### **3.1.1. CitiBike**

Citi Bike is one of the known bike-sharing systems currently in the US. Their systems reside in New York, Miami and a few other cities with thousands of bikes in each location. CitiBike utilizes a point-to-point system, meaning a user can pick up a bike at station A and drop it at station B. They're system is efficient and easy to use. The user can choose the time they would like to use the bike for and can pay for it. They can drop the bikes that they rent at any station in the city and will not get charged extra. The bikes have an RFID tag attached to them to allow for identification to the system at any given station. They also offer member services for residents, which allow the residents to use the bike any time they like; all they need to do is swipe their RFID membership tag and they're good to go.



Figure 3.2 - A citizen using CitiBike system in New York City.  
Courtesy of CitiBike\*

### **3.1.2. Juice Orlando**

Juice is a local Orlando bike-sharing point-to-point system that offers electric bikes as a means for clean transportation within the Downtown Orlando area. Their system is highly comparable to CitiBikes and they offer advertisement space as a means to generate extra revenue. They also provide real-time availability of bikes at each station via Android and iPhone applications and their website as well. They too offer membership services for locals who are interested in using the system frequently.



Figure 3.3 - Juice bike station located in Downtown Orlando.  
Notice advertisement space sold to VHB  
Courtesy of Juice Bike Orlando (\*TBD)

### **3.2. Demand analysis**

We conducted a survey on the UCF campus for one hour as a test bench. Our objective was to find out from students, personally, if they could envision UCF having a bike-sharing system and if that is something they would like to see UCF have. In one hour, we collected over 100 signatures. While collecting the data, not everyone either wanted to sign or participate in our survey however, the amount of negatives to positives was negligible and therefore we concluded that given 10 more hours of survey conductivity, we would be able to obtain approximately 1000 signatures. We believe this amount of students is enough to promote and instantiate the process of pursuing the implementation of a bike-sharing system on UCF and its neighboring communities for UCF students to use.

The proposed coverage area for UCF Main Campus would be 10 stations on campus and 5 stations off campus at university housing communities such as Knights Landing, Northview, Marquee, and Edge. We also propose two stations in Research Park.

Currently, there is a bike-sharing system in place, however it is manually operated, meaning, there is an individual to check each person in/out of their bike times. This system is located outside of the Student Union and has limited operational hours. It requires students to show proof of their student id's and makes them responsible for the bike and the lock given to them.

---

## 4. Standards

The following section will define the standards that will be used related to this project. Standards are important to be kept as they comply with specifications, allow a universal understanding for the system, and allow possible integration from other systems.

### 4.1. DC/AC Conversion

A DC/AC converter device requires a stable DC power source in order to supply enough current for desired power demands of the system. Some examples of standards DC input are:

- 12 VDC, for smaller consumer and commercial inverters that typically run from a rechargeable 12 V lead acid battery.
- 24 and 48 VDC, which are common standards for home energy systems.
- 200 to 400 VDC, when power is from photovoltaic solar panels.
- 300 to 450 VDC, when power is from electric vehicle battery packs in vehicle-to-grid systems.
- Hundreds of thousands of volts, where the inverter is part of a high voltage direct current power transmission system. [Wikipedia]

In general, there are two types of DC/AC conversion. One of them provides a sinusoidal modulated sine wave output. The other one is pure sine wave inverter which provides less distortion and proper sinusoidal sine waveform as output.

The standard for AC power supplies are vary to different region. In the US, that standard is 120V 60Hz VAC for most of resident electric appliances and other AC devices. Besides that, the electric outlet type is also concerned. The A and B outlet types are commonly used in US.

Because of its advantage, a fine sine wave DC/AC converter is chosen to design. The AC output voltage of that power inverter is controlled to be the same as the grid line voltage for standard. 120V 60Hz, even when the driven load changed. This allows the inverter to power several devices designed for standard line power.

### 4.2. Solar Panels

The photovoltaic solar devices have been standardized over the past decade. The performance of PV standards is created by International Electrotechnical Commission (IEC) under the article, namely IEC 61215 (Ed. 2-2005) and IEC 61646(Ed.2-2008). This article has set a specific test sequences, conditions and requirements for the design qualification of a PV module. The qualification of the design represent the PV module's performance capability under prolonged exposure to standard climates which is defined in IEC 60721-2-1. Other related standards (found in IEC 61730-1,IEC 61730-2 and UL 1703) address the safety qualification for a module. The performance of the photovoltaic solar devices makes an impact to the application of the solar harvesting system. The engineering application must follow a certain rule based on the specification



of the rating on the photovoltaic solar devices to ensure that it meets all the required specification.

### **4.3. Security Camera**

It is generally illegal to include audio recording in surveillance footage. This is because the laws note that if the recording is not taken with permission from the person that is being recorded, there is an expectation of privacy from that individual. Audio recording is normally only legal if the person doing the recording is actively taken part in the conversation. The video itself is allowed to be recorded in a public space. Places that aren't considered alright to record in a places where to reasonable expectation of privacy, such as a bathroom or changing room.

### **4.4. Battery Storage**

Any project involves big system battery has a high risk if it is not taken seriously. There are few standards required to follow in order to have battery system installing in the project

In every battery devices, there are groups of Battery Council International (BCI) number (e.g., U1, 24, 27, 31, 8D, etc.) which is based on the physical case size, terminal placement and terminal polarity. The standard is different in each region: For example, In Europe, the EN, IEC, Italian CEI, and German DIN standards are used and in Asia, the Japanese JIS standard is used. In these group of number, the ampere-hour or RC ratings, battery type and warranty vary in models of the same brand or from brand to brand.

There is a specific site to check for the BCI size information on the battery <http://www.exidebatteries.com/bci.cfm>. In general, the batteries are sold by their model, and sometime, they are sold by the group number which can results in same price. It implies that we can be able to purchase a larger battery with more ampere-hour or RC than the battery that we change. However, there are few cautions that we need to consider before replacing the battery are the connection as well as the size of the battery for the system

In application using, the battery must be stored in a particular place where only the certified technician is allowed to access.

One of the first thing that we need to avoid is to buy a wet lead-acid battery that is already operated more than three month old because by then it has started to sulfate unless it has periodically been recharged (this is not the usual practice of many retailers) or it is dry charged. The exceptions to this recommendation are AGM and Gel Cell batteries, which can be stored up to 12 months before the state-of-charge drops 80% or below.

Some of the manufacturer's date coding techniques are as follows:

*Delphi (AC Delco and some Sears DieHard)*

Dates are stamped on the cover near one post. The first number is the year. The second character is the month A-M, skipping I. The last two characters indicate geographic areas. Example OBN3=2000 February.



Figure 4.1

[Source: Interstate Batteries]

*Douglas*

Douglas uses the letters of their name to indicate the year of manufacture and the digits 1-12 for the month. D=1994 O=1995 U=1996 G=1997 L=1998 A=1999 S=2000 Example S02=2000 Feb.

4.4.3. East Penn, GNB (Champion), and Johnson Controls Inc. (Interstate and some Sears DieHard)

Usually on a sticker or hot-stamped on the side of the case. A=January, B=February, and the letter I is skipped. The number next to the letter is the year of shipment. Example B0=Feb 2000

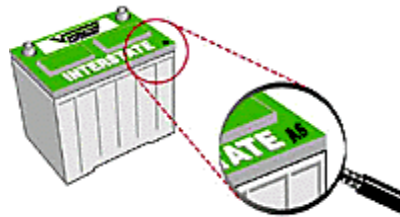

Figure 4.2

[Source: Interstate Batteries]

Exide (some Sears non-Gold DieHards)

The fourth or fifth character is the month. The following numeric character is the year. A-M skipping I. Example RO8B0B=Feb. 2000.

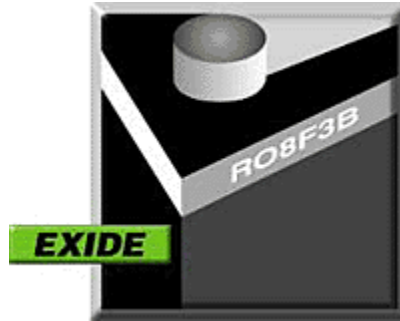

Figure 4.3

[Source: Interstate Batteries]  
Trojan

Stamp on post, 2 months after manufacture date.

Warranty - Usually the battery warranties are not necessarily indicative of the quality or the cost over the life of the battery. Generally, the manufacturers will prorate warranties based on the list price of the bad battery, so if a battery failed half way or more through its warranty period, buying a new battery outright might cost you less than paying the difference under a prorated warranty. The exception to this is the free replacement warranty and represents the risk that the manufacturer is willing to assume. A longer free replacement warranty period is better.

#### 4.5. Wireless Standard

The following table relates the wireless standards that the project must comply with if certain wireless components are to be used. The wireless standards used are IEEE based and span WiFi, Bluetooth and RF.

Standard	Description
<b>IEEE 802.11b</b>	Defines wireless-networking specifications up to 11Mbit/s up to 2.4GHz WiFi
<b>IEEE 802.15.1</b>	Defines wireless medium access control and physical layer specifications for wireless area networks. (Bluetooth specific)
<b>IEEE 802.15.4f</b>	Defines protocol for active RFID and sensor applications.

Table 2 – Wireless Standard

#### 4.6. Magnetic Card

Magnetic Card Standards vary depending on type and format. The various types of magnetic cards are ISO, ANSI, CDL, and AAMVA. The majority of financial and identification cards abide by ISO standards, hence this will be the standard that will dictate how we will be able to retrieve information from said cards.



*ISO/IEC Standard*

The International Organization for Standardization (ISO) sets the bar for all three formats. The specific dimensions for bit formatting are listed below depending on card type and information stored.

<b>ISO</b>	<b>7810</b>	Identification Cards
	<b>7811-1</b>	Embossing
	<b>7811-2</b>	Magnetic Stripe- LoCo
	<b>7811-3</b>	Location of embossed characters on ID-1 Cards
	<b>7811-6</b>	Magnetic Stripe - HiCo
	<b>7813</b>	Financial transactions Cards

Table 3 – ISO Standard

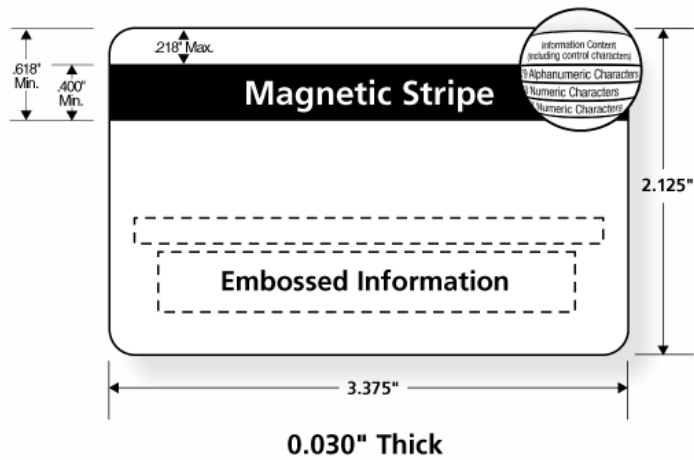

	0.223"		Recording Density (bits per inch)	Character Configuration (including parity bit)	Information Content (including control characters)
Q.110'	Track 1	IATA	210 BPI	7 Bits per Character	79 Alphanumeric Characters
Q.110'	Track 2	ABA	75 BPI	5 Bits per Character	40 Numeric Characters
Q.110'	Track 3	THRIFT	210 BPI	5 Bits per Character	107 Numeric Characters

Diagram illustrating the dimensions and recording parameters for three tracks of a magnetic stripe. The track width is 0.223". The total height of the stripe area is 548". The recording density and character configuration for each track are detailed in the table below.

Figure 4.4 - 3 tracks for magnetic cards via ISO Standards. Courtesy of Q-Card

**Card Data Format  
Track 1**

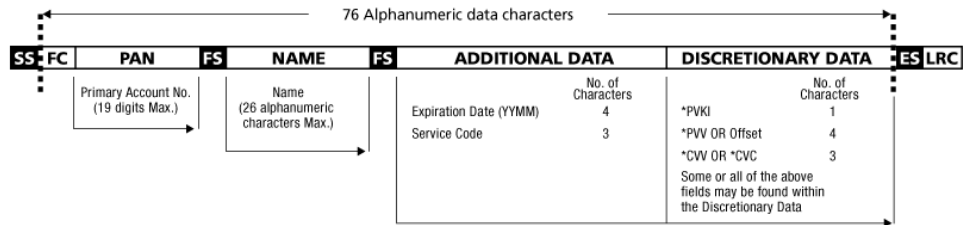

Shaded area identifies control characters

- SS** Start Sentinel %
- FC** Format Code
- FS** Field Separator ^
- LRC** Longitudinal Redundancy Check Character
- ES** End Sentinel ?

- \*PVKI PIN Verification Key Indicator
- \*PVV PIN Verification Value
- \*CVV Card Verification Value
- \*CVC Card Validation Code

**Card Data Format  
Track 2**

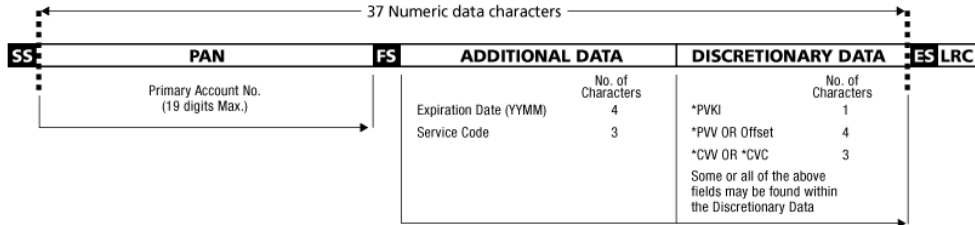

Shaded area identifies control characters

- SS** Start Sentinel Hex B ;
- ES** End Sentinel Hex F ?
- FS** Field Separator Hex D =
- LRC** Longitudinal Redundancy Check Character

- \*PVKI PIN Verification Key Indicator
- \*PVV PIN Verification Value
- \*CVV Card Verification Value
- \*CVC Card Validation Code

**Card Data Format  
Track 3 (ISO 4909)**

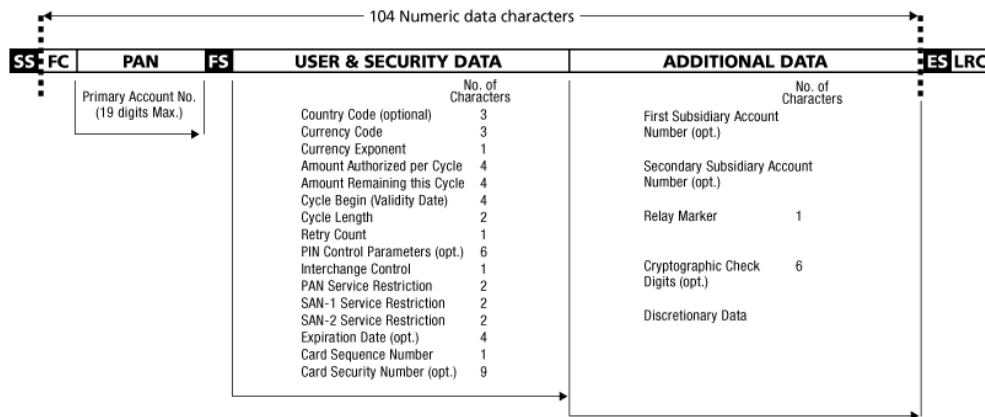

Shaded area identifies control characters

- SS** Start Sentinel Hex B ;
- FC** Format Code (2 digits)
- FS** Field Separator Hex D =
- LRC** Longitudinal Redundancy Check Character
- ES** End Sentinel Hex F ?

A Field Separator (FS) must be encoded if an optional field is not used.

Figure 4.5 Track format standards are pictured below.

## 4.7. RFID

There are a few set standards and regulations that need be following when utilizing RFID, especially when creating an RFID device. For our purposes, we will only be using RFID devices however, these are the standards that are constraining and assisting us. If in the future it made sense to design and fabricate an RFID reader or tags for the bicycles, these would be the standards to abide by.

It is important to note that there are two different major organizations that hold RFID standards. First, the ISO and second, Auto-ID Center, which developed Electronic Product Code (EPC) technologies, both whose standards conflict with one another. The ISO is the world leader when it comes to standards, and dictates whether or not a product is deemed ISO standardized. The Auto-ID Center is a company, whose objective was to develop low-cost RFID tracking systems, mainly used for inventory tracking and operated in Ultra High Frequency (UHF) due to read range.

*ISO Standards* (copied directly from RFID Journal.com)

ISO has developed RFID standards for automatic identification and item management. This standard, known as the ISO 18000 series, covers the air interface protocol for systems likely to be used to track goods in the supply chain. They cover the major frequencies used in RFID systems around the world. The seven parts are show in Table XX.XX

<b>ISO</b>	<b>18000-1</b>	Generic parameters for air interfaces for globally accepted frequencies
	<b>18000-2</b>	Air interface for 135 KHz
	<b>18000-3</b>	Air interface for 13.56 MHz
	<b>18000-4</b>	Air interface for 2.45 GHz
	<b>18000-5</b>	Air interface for 5.8 GHz
	<b>18000-6</b>	Air interface for 860 MHz to 930 MHz
	<b>18000-7</b>	Air interface at 433.92 MHz

Table 4 – ISO Standards for RFID

---

## 5. Realistic Design Constraints

The following section will overview the realistic constraints the project faced while research was conducted. These include but are not limited to physical, financial/economic, time, and environmental factors. A few of these factors due play a major role in any projects implementation, especially financial/economic.

### 5.1. Physical

Since our main focus for this project is lying in the electrical aspect for the system as a whole, the whole structure for the bike rack system will be limited to a certain level. There will be three big structural components involved in this project: The whole system structure, the locking structure, the battery bank storage structure. The material choice

for the structure is limited due to the limited in structural designing aspects. Most of the components that we will be using to build the structure this project will be mainly made of wood and plastic materials.

Our initial goal is to add few more features for our bike rack system like intelligent system beside lock/store/light/renewable energy features. However, not every features can be added to the limited space of the structure.

## **5.2. Time**

Time constraint plays a major role in every aspect of this project. The second half of this class will be done over summer, a semester shortened by four weeks. That is a valuable amount of time that most teams have over a regular semester. That means we need to be able to build, program, test and have this project fully functional by our July 10th deadline. We also need to allow time for parts to arrive, as not all the parts ordered were from the same distributor/manufacturer. We're also expecting to run into implementation problems and have set concurrent milestones for this expectation.

Since we will be presenting in July, our team deadline is three weeks prior to this date. The programming itself will also be extensive with mostly each team member having their fair share. Since time is of the essence, this makes an impact in our design decisions, as we may be purchasing certain module packages that may take care of a specific task, that may have been cheaper if we had more time to design it ourselves.

PCB board designs also need to be made. If time becomes a factor, we may have to send out our components to be soldered to the board, which comes at an additional cost. It may also be wise to do this incase an error is made during soldering, rendering any circuitry useless and a new PCB required.

The programming aspect also takes a hit with the time constraint. Efficient features built into the system for maintenance could be included, let alone a complimentary mobile application. Features such as keeping track of the battery charge and life would be very useful. System run time and other data statistics that could be implemented but the "meat and potatoes" of the project must come first.

The ability to learn more about the technology we are using is also a constraint handed by time. Learning more about security features in programming and RFID would be beneficial, however, these are mainly components purchased and used to execute a simple task. A final dent is that we aren't learning fully how cost effective some of these systems actually could be because of some of the DIY (sort of speak) modules that, for example, cost \$35 yet if we were to design and build it by hand, may only cost \$10 or \$15, allowing us to, not only save money, but realize an actual scalable product from front-to-back.

## **5.3. Economical**

Economic constraints played another key role in the design process and decision making. The financial road saw a lot of great choices scrapped simply because they were too expensive. A benefit to the project was the way funds were raised, through a GoFundMe account, which luckily, accrued over \$1000 within a week. Even though we had a budget now to work with, we still were short funds and the group divided any remaining costs.

The bulk of the expense came with the power system. Solar power is not cheap on a marginal standard or any standard at that. Panels range from the low end of \$125 into the thousands of dollars, of course depending on the power output and specifications. There is value in the price. Of course, the better the panel, the more stable and reliable it will be. Since we really only need this project to work for one month at the maximum, we made sacrifices by going with the lower end panels available.

As stated earlier, a high tech user interface runs parallel with higher cost. Implementing a beautiful 15" touch screen simply wasn't on the menu as our budget didn't allow it. In order to drive a 15" touch screen would also require more processing power, and with that more power in general. All come at a cost.

We also couldn't manufacture the roofing structure because the materials would cost 50% of our budget. With the other 50% for the power system, this would leave us with no capital for the remaining components of the project. The structure is going to have to be winged and most likely used wood. A simple paint job should suffice for appearance but as for this moment, a decision hasn't been made.

Using a top-end HD security camera was scrapped for the same reason, as what good is a security camera if you can't see the villain's face or features. Another lower end option was selected to suffice for the insufficient budget.

#### **5.4. Environment & Safety**

The bike rack is a system to be installed outdoors. The materials will thus need to be able to be sustained in an outdoor environment where it will be subjected to a multitude of weather patterns. Considering that we are focusing on this being used at UCF, meaning it will be used in Florida, it will need to largely be able to endure heat and rain. The electronics will need to be waterproof and need to have proper heat management systems.

The bike rack will have to be structurally sound, so that there is not a chance of events such as it collapsing. This will come to down to physics, based on the weight of the roof and the load being bared on each post on the four corners of the bike rack. In turn, this will affect the overall spacing and height of the rack to get optimal stability.

Other safety concerns include not having exposed wires, leading to people can get hurt from shock. The electronics will need to be hidden so that safely away so that people do not come in contact with them. This plays into the fact that they need to be waterproofed, as water will not only damage the electronics but will make them more dangerous. Also, the bike storage slots themselves will have to be a reasonable width so that the bikes can

slide safely in and out without people getting their hands or feet stuck while guiding the bike in.

---

## **6. Research**

The following section will overview in detail, the research conducted for the various components needed to implement the project. Research is a crucial factor in building a project as a team must know which parts will fit the specifications and requirements along with satisfying or limited to the constraints given.

### **6.1. Charge Controller**

In an off-grid photovoltaic system, charge controller plays a main role as the controlling brain of the system. It controls the flow of the power going out from the solar and into the battery system to protect the battery from being damaged. Also, it does also control the power going to the loads. As being the main controller, the charge controller has the ability to prevent the photovoltaic devices over charging the power backup batteries as well as under charging the batteries bank system. By sending an internal signal to check the battery voltage level and comparing it back to the power input from the panel, the integrated circuit inside the charge controller will perform the analysis in such a way that it will regulate the flow of charges coming out from the panels to match with the current level of the voltage and current inside the battery bank. Often in time, the charge controller is viewed as the charge regulator since it helps to regulate the charge flowing into the system and out with system monitoring inside each circuit.

For most of the off-grid system, the charge controller has the highest role because it can keep the backup battery system's life lasting longer. However, designing and implementing a charge controller for a certain system require many steps of measurement. There are many factors that are needed to be taken into consideration before building a right type of charge controller: what type of the system (Off-grid or Grid Connect), what is the rating power for the system (12V, 24V or 48V), and other external factors that can affect the system.

In today PV market, there are two main types of charge controllers: PWM (Pulse Width Modulation) charge controller and MPPT (Maximum Power Point Tracking) charge controller. Despite these charge controllers have the same functionality in regulating the charge flowing from the solar panel, they do have a unique design in of their own for certain purpose.

#### **6.1.1. Pulse Width Modulation Charge Controller**

The PWM (Pulse Width Modulation) Charge Controller senses the level of the capacity inside the battery. Based on the collected data from the monitoring system, the ICs inside the charge controller start adjusting the level of charging pulse going to the battery. If the charge controller realizes that the level of capacity inside the battery nearly reaches to its full charging status, the charging pulse width will be getting smaller and smaller until the

battery reaches its full state. The PWM charge controller will keep repeatedly checking the battery level at every cycle for a certain amount of time. The process will be the same for the discharged condition, if the monitoring system detect the capacity is at low level, the charging pulse will be send, the width of the pulse will begin with wide length and start getting shortened as the charge control sensing the battery's capacity level until it reaches to the nearly full state. The [figure 1] illustrate the graph of current vs voltage and power vs voltage.

One of the advantages of the PWM charge controller is the cost efficiency. The PWM is more applicable for small scale system where the temperature is moderate high (above 100°F)

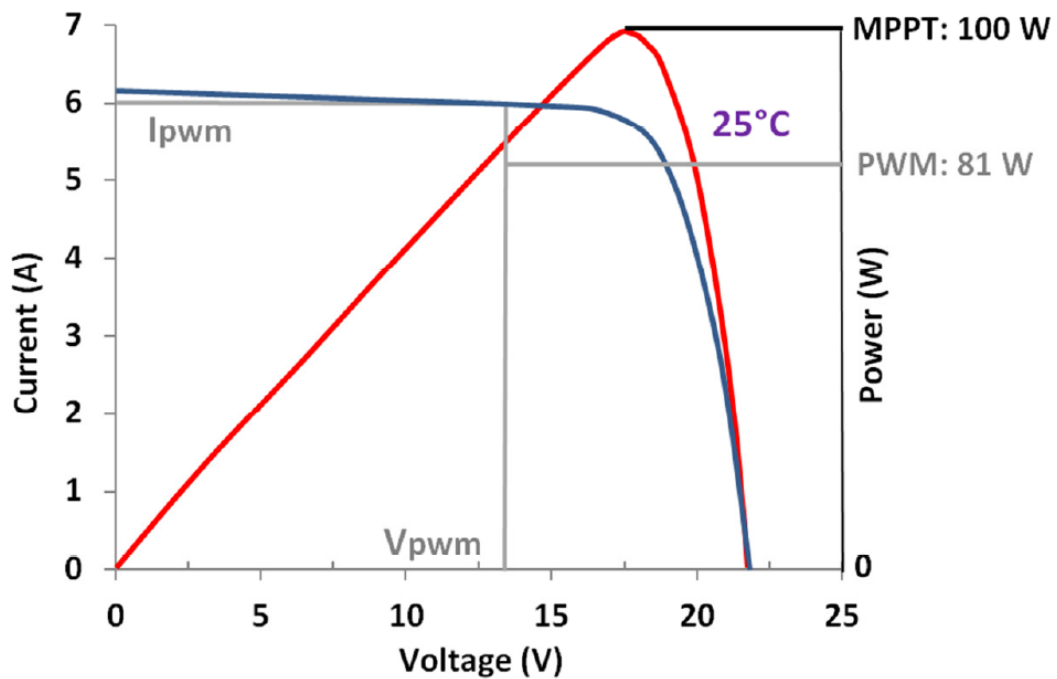

Figure 6.1.1 - PWM Charge Controller Current Vs Voltage and Power Vs Voltage Graph (Reprinted with Permission from VictronEnergy.com)

This graph is illustrating the 12V PV system where the powers are supplied from the 100W Crystalline PV panels as the specification below

<b>Maximum Power (Pmax)</b>	100W
<b>Open Circuit Voltage (Voc)</b>	21.60V
<b>Short Circuit Current</b>	6.32A
<b>Max Power Voltage</b>	17.4V
<b>Max Power Current</b>	5.75 A
<b>Max System Voltage</b>	1000VDC

■ Current starts at the "short circuit current" (6.32Amp) level and starts decreasing as the voltage level increasing

■ Power starts at 0W ( $W = V \times I$ ) increasing linearly as the voltage and current value increases. And it starts decreasing after reaching its maximum power.

■ Voltage at Pulse Width Modulation and Current at Pulse Width Modulation

If the capacity of the battery is at the full discharged level (low level), the charge voltage will be requested by the PWM charge controller. At the request process, the PV panels supply 12V also extra 0.5V (taking into account for voltage drop in cabling and controller). The charge voltage is then slowly increased by the charge controller in which it will stop when the full charge level reached. Power produced by PWM =  $12.5V \times 6A = 75 W$  (25% below the maximum power)

From above analysis, it shows that if we use PWM charge controller for our system, it will lose some power despite it is cost efficiency. Power efficiency will be more beneficial for long run than the cost efficiency, therefore we will not go with PWM charge controller.

### **6.1.2 MPPT (Maximum Power Point Tracking) Charge Controller**

In the maximum power point tracking MPPT charge controller circuit, the ICs will track for the maximum power point. After tracking for the maximum point, the MPPT charge controller will set the output for the  $V_M$  (maximum voltage) and draw the maximum current  $I_M$  from the solar panels. Then, the ICs in MPPT charge controller determine the difference in power between the battery and the input power coming from the panels. Inside the MPPT charge controller, there is a DC to DC transformer whose task is to transform the power with the higher voltage into the power with the lower voltage. During the DC to DC converting process taking place, the DC voltage will be converted into high frequency AC voltage ultimately it converts back into DC voltage for the case. In the figure 2 below, showing the graph of the current vs voltage and power vs voltage in MPPT charge controller



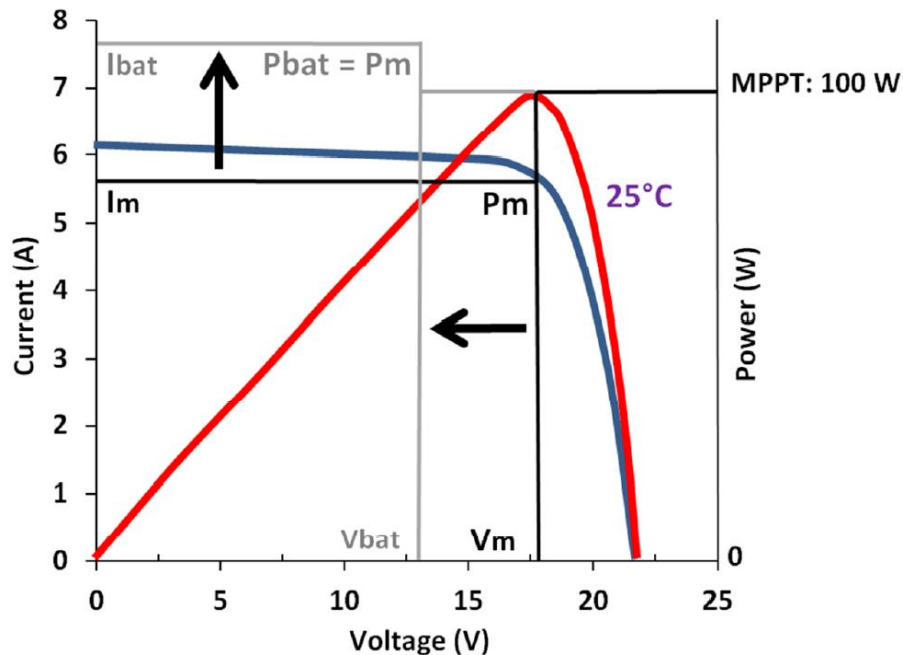

Figure 6.1.2 – MPPT Controller, graphical representation of the DC-DC transformation  
 $P_m = V_m \times I_m = 18V \times 5.6A = 100W$  and  $P_{bat} = V_{bat} \times I_{bat} = 13V \times 7.7A = 100W$

As above data analysis, the MPPT charge controller provide a better power efficiency to the system since it does not waste any extra voltages. If there is any extra voltage value, it will be converted into currents for utilizing.

For the system that we have, we expect more power efficiency coming out from the PV system since our loads depend solely the battery bank. Therefore, the maximum power point tracking charge controller is a better choice for our project. We expect to provide the battery bank with the maximum power performance from the PV in order for it to operate well. Another reason for choosing the MPPT over the PWM is that the MPPT offers microprocessor option which help to regulate the charge flow more actively, and the processor acts faster to prevent fault happening to the system. In term of cost, the PWM charge controller is cheaper than the MPPT charge controller but it may require more in maintenance cost.

#### *Maximum Power Point Tracking ICs Option*

Beside the main functionality of regulating the charge flow, the charge controller can be installed with some integrated circuits which generate additional functionality. The maximum power point tracking functionality is one of the most useful circuit feature for a charge controller because it improves power efficiency for the photovoltaic power system.

In the market, there are many companies offering the charge controller with installed MPPT integrated circuit. There are also MPPT integrated circuit available for purchasing separately.

One of the most efficiency way is to design a charge controller for the system that comes with MPPT integrated circuit installed.

## **6.2. Battery Storage**

One of the three main components of an off-grid solar power system is the power storage system. This component is playing as the heart of the system and the one that requires the most cares and periodical maintenances. Solar power storage is critically important to most of the off-grid power system (either it is using Wind-Turbine or it is using Photovoltaic System) because these renewable energy sources do not always supply constant power for a long period of time so most of the supplied powers which are requested by the loads are coming from the power storage. Therefore, choosing a right type of power storage can help to improve the system power efficiency and the overall performance.

### **6.2.1. Battery Backup System Selection**

In today market, there are a wide range of selections for solar power storage system which can be chosen depending on the type of the application and the limits of the budget. Among these types of batteries, lead-acid battery backup type seems to be the most common and preferable choice to most of the PV power application, especially for the small scale system like 12V, 24V, 48V and so on. While there are other brands available in the market today, such as nickel-cadmium and nickel-iron battery type, they are usually not common due to its expensive costs, high requirement for maintenance, and inefficiency. One of the lead-acid battery advantage is that it offers lowest cost as well as durable life.

Deep-cycle lead-acid battery type is our first and only preferable choice due to its practical condition and its specification matching our project requirement. The only unique feature for the deep-cycle type of battery is that it can discharge frequently or provide deep discharging cycle for a long period of time without any problem compared to other type. There are also other types of battery which also provide discharged power but it usually lasts not too long. Especially in the automotive starting battery type, it usually starts discharging with large current which can potentially destroy the small electrical component.

#### **6.2.1.1. Lead-acid Battery**

##### *Gelled Lead Acid Battery*

In the lead-acid battery product line, the gelled cell battery is one the three common types. This special type of battery is produced and developed after the flooded cell (which is discussed below) which has sealed cap with gel electrolyte. The name of this type battery implies the characteristic of it in term of designing and performance. The electrolyte on this particular battery is thicken by the effect of fumed silica (which is the thickening agent for the electrolyte). The purpose of having this fumed silica is to make the battery cells more stable, and also it prevents the cell from leaking when it is damaged. One of the main differences in the gelled lead-acid battery comparing to the flooded lead-acid battery type is that it requires less vent in term of storage, less maintenance needed, and it can produce slightly higher discharging rate.

One of the reasons people usually choose this type of battery for the project is that when they require to work under a less surveillance working environment. Since the technology in this gelled cell battery is developed after the flooded cell, it is expectedly more expensive than the flooded cell; however, in the return, the cost of maintenance is cheaper. Comparing this to the flooded cell, we think that this type is not our solution since it does not deliver the cost efficiency solution that we expected.

#### *AGM-Absorbed Glass Mat Lead-Acid Battery (VRLA)*

This type of the battery is the latest development in valve regulated lead-acid product lines. The AMG is designed and developed based on the need for a better protection when it comes to external effects which mainly caused by the environment. The electrolyte on this particular type of battery is held captive by the sheets of fiber glass. In term of protective features, the AGM type has some similar features comparing to the gel celled. One of the appealing features of the AGM when it comes to the storage is that the AGM requires less ventilation under normal condition. This feature has become more important since it gives more flexibility for a designer. Although the AGM is similar to the gel cell product line, it does have some distinguished features which make it more appealing to the consumer is that it is compatible with the flooded cell battery due to the fact that it uses the same charging voltage as the flooded battery. With this feature, the AGM is more preferable than the gel cell when it comes to PV system. However, the AGM is still not the common choice for small scale PV design because it is still very expensive.

#### *Flooded lead-acid battery (FLA)*

One of the three most common lead-acid batteries is the flooded lead-acid battery. This particular type of battery offers the cost efficiency solution for a small system PV solar project like ours, and it is also the most common choice when it comes to reliable energy storage system with affordable selection. In the physical design, the flooded batteries are unsealed with liquid electrolyte. During charging cycle, the water lost through gassing via the vent cap. Therefore, a secured storage box for the battery bank is required and inside the box, there must be a vent leading to the outdoor for preventing hazardous situation occurring. Additionally, flooded lead-acid batteries usually require periodic cares the most due to its physical condition. If the batteries are well maintained, the lifespan can be much longer than the other two type of the lead-acid batteries. In the market today, there are numerous manufacturers for the flooded lead-acid batteries, top leading brands like Trojan, Surrette, and Deka are well known for their reliable products in the PV industry with the wide range of selection in size, dimensions, and materials. For that reason, the flooded lead-acid battery is the choice for our power storage system solution.

#### *Golf Cart batteries (Flooded Lead-Acid Batteries)*

When it comes to flooded lead-acid battery, the golf cart battery is the most well-known family product. There are also other types of product in the flooded lead-acid battery series, such as automotive battery, boat battery...However, for the PV application purpose, the golf cart battery is the most preferable choice since it has the deep-cycle

characteristic. The golf cart battery usually comes with a standard of 6V rating and 215 Ah in 20-hour rating. The structure of the battery is very well constructed and protected due to its thick and strong skin protective layer. It can perform well under harsh weather condition (working under temperature range 40°F to 100°F ) which is applicable for Florida weather. In order to maintain the battery, it must be checked frequently for the storage capacity status of the battery. As the matter of fact, the golf cart battery cannot be allowed to be under low discharged because it can damage and shorten the lifespan of the golf cart battery.

Beside all the required technical treatments for this particular type of battery, it is a great solution for a small scale PV system. In the economic term, the golf cart battery is the most cost efficient choice for our project. Although there are numerous selections for golf cart shopping online, we decide that we will go with the one produced by Duracell manufacturer. The reason is that it saves us money and saves us time. Most of the golf cart batteries from well-known manufacturers usually require online transaction and shipping process since most of these are not sold locally. Duracell golf cart batteries are available at the local Sam Club, which makes more convenient for us in term of buying and safe transportation because it can reduce the shipping cost which lower our project cost.

#### 6.2.1.2. Battery Performance vs Temperature

One of the factors that can affect the performance of the battery is temperature. Having the battery operating under a certain temperature level can result in the changing of the capacity in the battery as well as the life cycle of the battery. It is critical to check for the rating specification of the battery, especially, we need to check on to see what is maximum or minimum power rating for the battery system

The figure [] below demonstrate the how the temperature in Celsius rating scale can affect the capacity of the battery

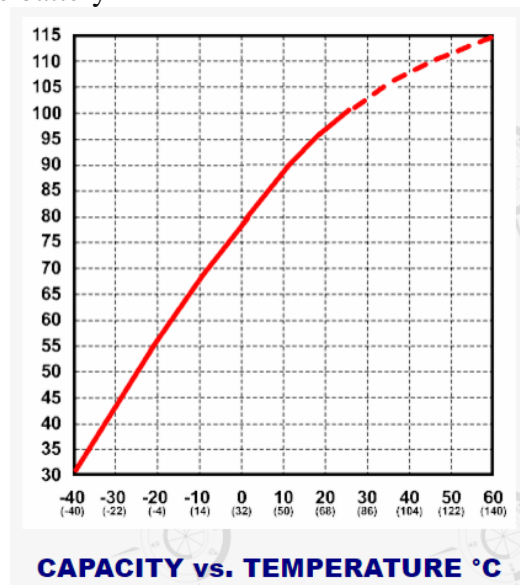

Figure 6.2.1 Battery capacity vs Temperature

Source: Concorde

The graph has shown that as the temperature increase, the capacity of the battery is also increased, vice versa. In a real design, we want to have our battery system being stored inside a certain level of temperature that can still keep it to perform its maximum scale, but not too much for it to be damaged.

*The Battery Data Comparison for Battery Storage System Choice*

The table 5 and the table 6 below show the data comparison between battery type and its lifespan as well as the battery type efficiency. These value help us to choose what the best type of battery for our project.

*Battery LifeSpan*

Marine Battery	1-6 years
Golf Cart Battery	2-7 years
AGM Deep Cycle	4-8 years
Gelled Deep Cycle	2-5 years
Deep Cycle	4-8 years
Rolls-Surrette premium deep cycle	7-15 years
Industrial deep cycle (Crown and Rolls 4KS series)	10-20+ years.

Table 5 - Comparison of batteries lifecycle

[6](source: <http://www.solar-electric.com/deep-cycle-battery-faq.html#Temperature Effects on Batteries>)

*Battery Performance Efficiency*

Type of Battery System	Efficiency Rate
Lead-Acid Battery type	The efficiency Rate is 85%-95%
NiCad (Nickel Cadmium)	Low efficiency (65-80%)
NiFe (Nickel Iron)	Low efficiency - may be as low as 50%, typically 60-65%.

Table 6 – Comparison of battery performance efficiency

[7](source: <http://www.solar-electric.com/deep-cycle-battery-faq.html#Temperature Effects on Batteries>)

### **6.3. Photovoltaic System:**

Solar Power Systems are becoming the fastest growing and the most popular energy supplied systems among other renewable energy sources which provide clean and efficiency energy. They come with different type of sizes, different type of specifications to provide renewable energy to variety of applications. Choosing a right type of solar power system for an application is not simply done by making arbitrary decision. It requires a measurement not only based on electrical aspects, but also on economic aspects. Larger power solar panel is not always an ideal selection to small loading demand applications such as this project. Therefore, the decision in finding a proper solar panel depends on many factors which are being grouped in different category.

Among these group selections, making decision between having a system connected to the grid or having a stand-alone system. There are two main type of solar power systems in the market today that can be installed and utilized by both industries and consumers:

- Grid-Connected Solar Power System.
- Off-Grid (Stand-Alone) Solar Power System.

Each of these systems has its own unique advantages as well as disadvantages. And that each system can provide a great benefit to the engineering standpoint depending on which type of application that it can be utilized into, and also depending on the limit of the budget for the projects.

#### **6.3.1. Grid-Connected Solar Power System**

Grid-Connected Solar Power System is the system having the photovoltaic devices connecting to the utility grid through the inverter and requiring no need for the power back-up storage system. Since the system is tied to the grid, it provides the dual solution to both problems in powers, power outage and extra power supplied. In the power outage case, the load demand will be supplied the power from the utility grid if the power from the solar panels are not generated enough for the application to operate. In the extra power case, the extra power supplied from the solar panel can be directly transferred into the grid when the loads are over supplied; with this solution, the potential damage to the device due to overpower supplied can be reduced and also no unused power will be wasted.

The cost of having Grid-Connected Solar Power System would be less than the Stand-Alone System since the batteries are not included in the system component list. The batteries are not needed because most of the power flow actions take place between the grid and the loads. However, this system is limited when it comes to flexibility in location and also some add-on features to the project application. In other words, the photovoltaic devices (solar panels) of the grid-connected system are usually being mounted in a fixed location since the wiring system for these solar panels have to connect through the inverter system which connect to the grid on the other end.

The electrical conducting wires for the Grid-Connected system are sized differently from the Stand Alone system because they are required more power protection from being connecting to the local grid which have higher potential to damage the system or even the application due to its high power. The grid-connected system can be less in economic aspect but it may require more in engineering technical aspect which explains why all the large scale application such as the power generation system always require the system of grid-connected.

### **6.3.2. Off-Grid (Stand-Alone) Solar Power System**

Off-grid solar power system is not required to connect to the grid as the other system, but it does require to connect to a power storage system (backup system) for power maintain and power protection. Since the system does not require any connection to the utility line, the installation becomes more simply and it can be a proper choice for some eco-friendly applications which do not require any power supplied from local utility. One of the main factors making the off-grid system more preferable is the independent characteristic. Since the system is not installed on a certain fixed location, it can be mounted on any place for its functionality purpose. Mostly, this system is preferred to be placed where the utility pole or grid cannot reach too.

However, for the system to be considered as a functional system, it always requires power storage solution which is always incorporated with the system as a whole. And for most of the time, rechargeable back-up batteries are always viewed as a better solution for power storage system than any other system. Usually, the backup power batteries have a wide range of selections based on the demand of the loads and also the budget for the system.

After choosing a right type of power storage system, the charge controller can be designed next. The charge controller is functioning as the controlling brain for the off-grid system. In the system block diagram design, the charge controller block is always placed between the solar photovoltaic system block and the power storage system block which shows how important it is for the main system.

To find a proper off-grid system for an application, many considerations must be made by these following questions: how much power the system will need to operate, how long can it be operating without sun power's presence, what is the maximum budget of the application, all the constraints included in these considerations. Once all these requirements and specifications are defined, the system can then be designed for desired solution.

### **6.3.3. Size**

An energy efficiency system does not have to be an expensive one, nor a sophisticated technical designed one, but instead, it must be a precise measured system. In order for it to be considered as a precise measured system, two factors must be considered and defined: first) what will the system be used on? Second) how will the system be used on? Sizing a system needs the numerical analysis on how much the power it must be used.

Usually, there are more simply ways looking at this problem. Previously, defining what the system will be used (grid connected system or off-grid system) always give a hint to how much power the system will be required to generate.

Grid-connected system solar power always generate more power with a larger cell power. The off-grid system is used more in smaller scale. Particularly, for the off-grid system, it usually comes with a clear defined power group: 12V system, 24V system, or 48V system. These are usually standard sizes for the off-grid solar power system design. Also, in the off-grid system, sizing the photovoltaic always help in the design process as well as the implementation process.

Recall that in the off-grid system, the photovoltaic device (solar panel) is not defined as a complete system, it always come with other components: the charge controller and a battery. And this is why it is more critical for the off-grid system than the grid connected system when it comes to define what the load demands must be because every other parts depend on one another. For making a right measurement for the system, all the parameters of all the electrical components must be defined: voltage value, current value, and the usage hour value. These values are extremely important in making a better operating and energy sufficiency system.

Below is the list of required numerical defined parameters:

- Voltage Value (Active Mode)
- Current Value (Active Mode)
- Current Value (Low Power Mode)
- Usage Hour for the application

#### **6.3.4. Photovoltaic 12V System**

In today design, PV 12V system is widely used in many applications. Since the voltage rating are at a sizable and feasible level, it provides a lower cost in wide range of applications. When designing a 12V system, every device in the system and in the application must be in 12V rating. Having all the components in the same rating voltage level is extremely critical because it not only help the system to prevent from potential damage, but also bring more efficient to the system. To ensure this, our backup batter system, to our charge controller must be in 12V rating level. When we design the bike charging station, we ensured that the inverter DC-AC will only accept 12VDC as input and convert to 120VAC output. When the system runs at low voltage, it reduces the cost in many ways because system with lower power always cost lower than system that has higher power rating.

#### **6.3.5. Photovoltaic 24V System**

In 24V system, as in the designing perspective, it offers less current rating value to run the system than the 12V, which the conducting wires can be smaller in diameter. This leads to reduced heat dissipation in the system when the current rating is not the main driven force. However, it costs more than the 12V system because, as being expected, when the system in 24V, every other component must also be in 24V rating voltage level



to keep the system operating efficiently. Since our system solely runs on 12V rating component, and the budget that we have for this project is extremely limited, this is why having 24V system will not a good strategy for our project.

### **6.3.6. Solar Cell Technologies**

One of the important things in finding a right photovoltaic solar device for the system is the select the right type of photovoltaic cell type for the application needs. By definition, solar cell, as known as the photovoltaic cell, acts as the electrical device that can convert the photon cells which are composed in the sunlight into utilizable electricity. And the process is call the photoelectric effect in which the electrons are emitted from the matter (metals and non-metal) when the energy of electromagnetic radiation of short wavelength is being absorbed. These electrons are known as the photoelectrons.

Over the year, these cell technologies are being improved and developed into more power efficient cells that the size can be reduced smaller but the powers still remain the same or even higher.

There are two main types of cell technologies available in the market today:

- Crystalline Silicon Cells
- Thin Film

Choosing between crystalline silicon cell solar panel and the thin film is based on the budget, the efficiency in energy converting into electricity, and also the reliability of the product.

#### **6.3.6.1. Crystalline Silicon Cell Solar Panels**

Crystalline Silicon cell solar panel is the most popular and well-known type in the solar market today. The c-Si cell is made of silicon layers which the photon energy will transfer through the semiconductor layers N type and P types. It's common today due to its reliability and that it delivers the efficiency in range of 15% to 25%. However, c-Si cell is not a great material to absorb light, which still needs to be improved. The Crystalline Silicon Cell Solar Panels are sorted into two different types: Monocrystalline Silicon Cell Solar Panel and Polycrystalline Silicon Cell Solar Panel.

##### *Monocrystalline Silicon Cell Solar Panel*

This photovoltaic cell is the original cell and the first cell being created. The monocrystalline cell modules (also being known as the single crystal cell) offer the highest efficiency compared to other, which occurs to be at the range of 15% to 20% in power conversion. Since these single crystal cell solar panels provide more power efficiency which makes them more expensive than other cell solar panels. Comparing to other types of solar cells, the monocrystalline silicon cells tend to generate more electricity in low light condition which is extremely critical. Even though in Florida during day time, especially most of the time, the weather is always bright and full of sunlight, but there always comes unexpected changing in weather that can make a big effect on the application.

### *Polycrystalline Silicon Cell Solar Panel*

Polycrystalline silicon cell, unlike the single crystal silicon, is composed of many of the smaller crystals which leads to the degrading in power efficiency. Reducing in power efficiency leads to reducing in the cost. Polycrystalline Silicon Cell Solar Panel cannot generate better power efficiency when they are works in the high temperature environment. This factor does not really make a big impact on the application so they can be negligible. The rating efficiency of the cells is around 13%-16% still very high compared to others but not to the monocrystalline. Since our project contains only low power consumption devices and the budget for our project is limited, the polycrystalline silicon cell solar panel would be a better choice for our application.

Our bike rack system composed very less power consuming devices, except for the AC charging station. Most of the microcontrollers in the system would be TI-products which the power consumption can be negligible, and most of the time, when the system is not in operating mode, it automatically enters into the low power mode system which makes it more energy efficiency. After all, the polycrystalline silicon cell solar panel seems to be a great choice because of its lower cost and its good rating efficiency in power.

### **6.3.6.2. Thin Films**

The thin film cell technology is new to the market today, even though it has been used in a wide range of application. Noticeably, this new technology is less expensive than the crystalline silicon cell technology, but in the trade-off, the thin film cells are far more less efficient than the crystalline silicon cell which in the realm of 20% to 30% light to voltage conversion. The thin cell solar panels are thinner and more flexible than the Crystalline Silicon, which makes them more popular in application required less space and lighter, thereby if we want larger power input we have to install more of the thin films. Comparing to the polycrystalline solar cell, the thin film panel can have a higher cost effective, but way less in term of power efficiency which is not ideal for our project. We may choose any product which has a cheaper cost for our project but it must still maintain a certain level of power performance.

Table of Data showing comparision between Monocrystalline vs Polycrystalline vs Thin Film

This table of comparision is made based on the 100W 12V System Panel

<b>MONOCRYSTALLINE vs POLYCRYSTALLINE vs THIN FILM</b>			
<b>TECHNOLOGY</b>	<b>MONOCRYSTAL LINE</b>	<b>POLYCRYSTALLINE</b>	<b>THIN FILM</b>
<b>EFFICIENCY</b>	efficiency typically within the range of 135-170 Watts per m2 (13-17%, with notable exceptions).	typically 120-150 Watts per m2 (12-15%, with notable exceptions).	typically 60-80 Watts/m2 (6-8%, with notable exceptions).
<b>CONVERSION EFFICIENCY</b>	18% conversion efficiency	18% conversion efficiency	6-8%, with notable exceptions).
<b>TEMPERATURE</b>	Outstanding performance in cooler conditions	Slightly better performance in hotter conditions	Optimal efficiency in hot weather, less effective in cooler conditions
<b>PHYSICAL DIMENSION</b>	Big Dimension in size	Big Dimension in size	Small Dimension (Requires 2-3 times more panels and surface area for same output as crystalline.)
<b>WEIGHT</b>	Heavy	Heavy	Light
<b>RELIABILITY</b>	excellent life span longevity. Usually come with a 25yr warranty	excellent life span longevity. Usually come with a 25yr warranty	Expected lifespan is less than crystalline panels.
<b>MAINTENANCE</b>	Low Required maintenance	Low Required maintenance	Medium Required maintenance
<b>COMPATIBILITY</b>	Works well with typical charge controller	Works well with typical charge controller	Works well with typical charge controller
<b>COST</b>	Range \$150-\$200 per each panel	Range \$120-\$180 per each panel	Range \$150-\$200 depend on the length and the size

Table 7 - Comparison between Monocrystalline vs Polycrystalline vs Thin Film

### **6.3.7. Configuration for Solar Panel Wiring**

Wiring solar panel system can be considered based on how much the power the system would require. It takes into account of many factors such as the power rating of the batteries, the power rating of the charge controllers, and the maximum value of the voltage and current the loads can handle. There are three typical configurations for wiring the solar panel system: (1) Wiring in Parallel configuration, (2) Wiring in Series configuration, (3) Wiring in Combination configuration. Each of these listed configuration can make a big impact to the system especially to the off-grid system which the exceed powers have to be taken into consideration.

One of the advantage of choosing a right wiring for the solar panels is to improve the system power dissipation, prevent over charging power or under charging power to the batteries or the load, and save money from buying expensive high power photovoltaic devices. In the market, the panels with higher rating voltage or current always cost more than the typical panels with 12v and 8.3A rating values.

#### **6.3.7.1. Parallel**

One of the most common type of configurations is parallel configuration. With this configuration, the system will still remain the same rating voltage of each panel, but increase in the rating current value. In the market today, a panel with 12V and 8.3A is always cheaper than a panel with 12V and higher rating current. For most of the components used in the application, may require only 12V rating voltage, but require more currents to run the system. In our case, the solar panel that we used has the rating voltage is 12V and 8.3A for current. If we connect another identical panel, the system will end up having the rating voltage 12V (which remains the same in parallel configuration) and the rating current is 16.3A (adding up by twice). By having the system in the parallel configuration, the current will be the main driven force for the operating application.

One of the main benefits of having the current to be the main controlling variable as in design terms is that most of the electrical applications are driven by current. Different level of currents can drive the system in many different ways. In our case, we need variety of current input for different applications: the lighting system, the security camera system, the sensor circuit, the microcontroller, and the DC-AC converter. Each of the applications requires different input rating current. Some require constant currents, some require varying current input. Another benefit of having the current to be the controlling variable would be safety. It is easier for protecting the system by keeping the current regulated than the voltage. Since there is DC-AC converting as a part of one of our applications, having the current as the driven input can help to optimize the system for efficiency purpose.

However, there are also few disadvantages that are needed to be taken into considerations: having current too large (by wiring the system in parallel) will require

larger and more expensive conducting wires, if the distance from the solar panel to the charge controller are too long, the voltage input have high potential to be dropped and the variation between the input and the output can cause the system inefficient which we all want to prevent.

### **6.3.7.2. Series**

Another way wiring the solar system is to wire them in series configuration. Using this wiring configuration, we will expect that the current value will be kept constant while the rating voltage values will be added up by the amount of solar panels. This configuration helps the system which is run by the voltage input that if we have two panels with 12V rating and 8.5A, the output will end up to be 24V rating and 8.5A. Most of the diodes and transistors can be activated only by when the voltage reach to a certain level. One of the benefits of using voltage as the input source for operating the system is that there is a certain level of voltage can be adjusted by using the voltage regulators. Since the current input is constant, it offers lower cost when it comes to choosing conducting wires.

Unlike the parallel configuration, the series configuration seems to be more efficient when it comes to long distance wiring because the it will help to prevent the system power losses over long distance connection to the charge controller. As in our case, our system will not be affected by the power losses that much since the connection from the photovoltaic to the charge controller is less than 10 feet long. We will reconsider our wiring system to this configuration if the other configuration is not efficient for our system, otherwise we will stick to the other configuration.

### **6.3.7.3 Combination**

It seems that this configuration offers better solution for a large scale application which utilize the most energy from solar panels. This configuration is the combination between the parallel and series configuration in which the voltage and the current rating value can be added up depending on the specification of the demands. In the technical design, the two positive terminal of the first two panels will connect on the same wire (parallel configuration) and that same specific wire will connect to negative terminal the next solar panel (panel number 3) as continue the positive terminal of the solar panel number 3 will connect to the negative terminal of solar panel terminal number 4 which the positive terminal of the solar panel 4 will be the positive terminal of the over all system while the negative input of the overall system will be coming from the negative terminal of the parallel panels 1 and 2. Having the system to be constructed in this configuration, the system will be more efficient in power, and more cost effective. However, in order to have this configuration setting up for the system, there requires at least four panels for the system.

### **6.3.8. Wire and Connector Component**

One of the factors which can determine the efficiency for the power system is the electrical conducting wires and the electrical connection component. Choosing a wrong

type of conducting wires can result in reduced power efficiency for the system and potentially causing huge damages to the electrical component as well as the loads. Most of the time, photovoltaic panel manufacturers offer a standard conducting wires as well as the connection components for the PV panels. These standard components are set so that it can prevent confusion for the buyer as well as the manufacturers.

Today in the market, most of the wire connection standards are based in the Wiring System, Article 690 in the National Electric Code (NEC) NFPA 70. Depending the size of the PV panel rating power, the rating power that the wires can be able to handle must be match or higher in order to prevent over heating the wires which can result in damaging the connection which can cause power losses internally in the system.

#### **6.3.8.1. American Wire Gauge PV Conducting Wires**

When choosing the PV extension cable, American Wire Gauge (AWG) seems to be the most popular choice among other and trusted choice in PV industry. AWG offers variety of selection depending on how the system being design. Smaller size in diameter can result in smaller current carrying capacity. The current carrying capacity is the rating value based on the input rating current generated from the PV systems. In our case, our current rating will be in the range between 13.8-22.0 A, which requires a Gauge no.10 based in the TABLE 1 (AWG Wire Size and Ampacity).

For our project, we want to use the 10 feet extension cable which is produced by WindyNation as the conducting wires. The first reason is that this extension cable is produced from the same company that produces the solar panel product that we chose. Second reason is that this extension cable has the specification which can handle the PV system that we have choose.

AWG gauge	Conductor Diameter Inches	Conductor Diameter mm	Ohms per 1000 ft.	Ohms per km	Maximum amps for chassis wiring	Maximum amps for power transmission	Maximum frequency for 100% skin depth for solid conductor copper	Breaking force Soft Annealed Cu 37000 PSI
0000	0.46	11.684	0.049	0.16072	380	302	125 Hz	6120 lbs
000	0.4096	10.40384	0.0618	0.202704	328	239	160 Hz	4860 lbs
00	0.3648	9.26592	0.0779	0.255512	283	190	200 Hz	3860 lbs
0	0.3249	8.25246	0.0983	0.322424	245	150	250 Hz	3060 lbs
1	0.2893	7.34822	0.1239	0.406392	211	119	325 Hz	2430 lbs
2	0.2576	6.54304	0.1563	0.512664	181	94	410 Hz	1930 lbs
3	0.2294	5.82676	0.197	0.64616	158	75	500 Hz	1530 lbs
4	0.2043	5.18922	0.2485	0.81508	135	60	650 Hz	1210 lbs
5	0.1819	4.62026	0.3133	1.027624	118	47	810 Hz	960 lbs
6	0.162	4.1148	0.3951	1.295928	101	37	1100 Hz	760 lbs
7	0.1443	3.66522	0.4982	1.634096	89	30	1300 Hz	605 lbs
8	0.1285	3.2639	0.6282	2.060496	73	24	1650 Hz	480 lbs
9	0.1144	2.90576	0.7921	2.598088	64	19	2050 Hz	380 lbs
10	0.1019	2.58826	0.9989	3.276392	55	15	2600 Hz	314 lbs
11	0.0907	2.30378	1.26	4.1328	47	12	3200 Hz	249 lbs
12	0.0808	2.05232	1.588	5.20864	41	9.3	4150 Hz	197 lbs
13	0.072	1.8288	2.003	6.56984	35	7.4	5300 Hz	150 lbs
14	0.0641	1.62814	2.525	8.282	32	5.9	6700 Hz	119 lbs
15	0.0571	1.45034	3.184	10.44352	28	4.7	8250 Hz	94 lbs

Table 8 – American Wire Gauge Wire Size and Ampacity



**Extension Cable  
Brand Choice: WindyNation  
Technical Specifications**

- Wire Thickness: 10 AWG**
- Stranding: 8**
- Insulation Thickness: 0.075 inches**
- Nominal Outer Diameter: 0.28 inches**
- Approximate Net Weight : 17.54 ft/lbs**
- Ampacity 90°C Wet/Dry: 40A**

Figure 6.3.8.1 - WindyNation Extension Cable  
[Pending Permission from WindyNation ]

**6.4. Locking Mechanism**

For security and theft deterrent purposes, we will need to incorporate some type of locking mechanism or device to secure the bike in place while it is not in operation. There are various types of locks that can be used from analog combination padlocks to

electric solenoids to original key locks. The various types of locks also incur a cost not only in price but also to the user experience. A difficult locking system could frustrate users and prevent them from using the system in the future. We will evaluate a few different options for locking mechanism and choose the locking system based off desired variables.

Combination Ulocks are a slightly upgraded versions of original padlocks, which required a key. Combination Ulocks are useful as they require usually a three to four digit sequence in order to unlock. They also could have a spin wheel, which usually requires a certain amount of turns and stops at specific numbers to unlock the padlock. These locks are marginally inexpensive, ranging from \$15 to \$20 per lock. The locks are very durable and have an almost lifetime shelf life. However, this would not be a viable option in our system, as it would require the user to hold on to the lock and not lose it. This is an uncontrollable variable from our stand point and is not beneficial if users continue to lose locks, or simply take them for themselves. It would not only cost the system another Ulock but most likely, an additional bicycle as well.

A solenoid is an electromagnet-based device that pushes or pulls a shaft. Sort of like a motor that moves in and out instead of spinning. Solenoids are widely used as momentary actuators in locking systems. Those devices are electromagnetic based which can either push or pull. Solenoids work likely as motors that moves in and out instead of spinning.

Solenoids come in a range of voltages, usually from about 12v-48v DC to 120V AC. Generally they are binary devices, either off or on. Solenoids also come in many types. One type of solenoids is "continuous duty", meaning it can be turned on and stay on during operation. Other solenoids only operate in a period of time and turn back to off mode after that. Pull-type solenoid pull the shaft in when they are turn on. On the other hand, Push-type solenoid push the shaft out when they are activated. A few are bi-functioned, they can either push or pull the shaft when their polarities set differently. Generally, Pull-type solenoids are more widely used. When you turn off the power from a solenoid, the shaft doesn't return to its zero position, so you need external force like spring force to either pull or push the shaft back to its initial position until it is activated again.



	A420-066843-00	A420-064867-00	A420-066842-00	A420-064866-00
AC/DC	DC	DC	DC	DC
Volts	12 VDC	12 VDC	12 VDC	12 VDC
Push/Pull	Pull	Pull	Pull	Pull
Duty Cycle	Intermittent	Intermittent	Continuous	Continuous
Stroke	1.00 in	1.00 in	1.00 in	1.00 in
Pull Force	20 Oz	10 Oz	8 Oz	3 Oz
Resistance at 70F	5.6 Ohm	4.6 Ohm	17.5 Ohm	14.8 Ohm
Power	27 VA	32.4 VA	8.6 VA	10.2 VA
Current Seated	2140 mA	2580 mA	686 mA	811 mA
Holding Force	205 oz	160 oz	179 oz	139 oz
Style	Tubular	Tubular Long-life	Tubular	Tubular
Model No.	T12x19-12	T12x19-I-12	T12x19-C-12	T12x19-C-12
Intermittent Duty Condition	25% 'On' Time, (100 Seconds 'On' Max. Followed By 300 Seconds 'Off' Min.)	25% 'On' Time, (100 Seconds 'On' Max. Followed By 300 Seconds 'Off' Min.)		

Table 9 – Comparison of Solenoid Types

In this project, pull-type solenoids are used for wheel locking system because of its reliability and easiness. However, because of the variety of wheel size and limited power supply, we have to look for a low power solenoid which are still able to secure any type of wheel. After the research, the TP8X16-C-12D Tabular Solenoid manufactured by Guardian Electric is considered to use. It leaves a wide space (1inch) for any type of wheel size and uses 12V DC voltage to operate.



TP128X19-C-12D Tabular Solenoid  
(Courtesy of Guardian Electric)

## **6.5. Power Distribution System**

There are two essential parts in power distribution of this project which are DC-to-DC Inverter and DC-to-AC Inverter.

### **6.5.1. Power Converter**

There are two essential parts in power distribution of this project which are DC-to-DC Inverter and DC-to-AC Inverter.

#### *DC-to-DC Converter*

The contribution of the DC-to-DC is in order to supply microcontroller system as well as other electric components using DC power. The DC-to-DC is built mainly based on the knowledge of operational amplifier and voltage regulator. The advantage of op-amps converter are consuming less power and having high efficiency. The regulators provide a stable voltage and easiness of usage. In other to convert 12V DC voltage from battery bank to variety of different voltage needs, we come up with a design of DC-to-DC Converter with multiple outputs so the design will be simplified and cost less comparing to building many similar circuits.

#### *DC-to-AC Converter*

The DC-to-AC inverter is designed to provide a charge station for students' electric bikes and other devices of their needs. There are many types and brands of these inverter but we desire to build our own devices with lower cost and power consumption. Besides the inverters, the research about the Power Distribution System also includes protection plan for components and how we wire them.

The DC-to-AC is more complicated. In market, there are two types of DC-to-AC Inverter which output Modified Sine Wave or Fine Sine Wave. The Fine Sine Wave Inverters are more complex and more expensive but they protect devices better. In other to better protection for student's electric bikes, we would design this type of inverter.

The knowledge we used to build the DC-to-AC Inverter is Pulse-Width Modulation. A reference square waveform and a carrier triangular waveform are generated from battery DC voltage (24V). Two signal would be put into a comparator device to create PWM signal. This signal would feed a Low/High Side MOSFET Driver in a desired frequency and amplitude. The Driver would then control an H-bridge MOSFET configuration under applied 110V voltage. A converter at the end will output a fine sine wave with 110 V and 60Hz frequency which supply to charge electric bike properly.

## 6.6. Security Camera System

A security camera system will be implemented in case peoples' bikes get stolen, so footage may be reviewed by an authority. The security camera will also work as a theft deterrent, so hopefully less bike thefts happen overall. There are two different camera options that we are to decide between, the choice will be coupled what is decided to be the best MCU option for the camera, since they have different eases of implementation depending on what type of MCU they are to be interfaced with.

### 6.6.1. Web Camera

Webcams generally come with a built in microphone since they are used for conversational purposes. If a webcam were used, the microphone would need to be disabled to give people their privacy and to adhere to legal restrictions. The wired connection to the USB port of a webcam will make it easier to set up on the bike rack. Webcams are also rotatable, which is another way that makes it easier to get a proper filming angle on. Webcams tend to be double the price of the Raspberry Pi camera discussed below, and cost is a prohibitive aspect of this project.

The cameras have similar resolution and price and are both viable options for the project. The Table X.X details the options in a side-by-side comparison. Considering how similar these options are, it will be important to read user reviews to make to see what people have noticed while using these cameras. There are many more different cameras out there that vary from the ones given here, however, there were much more expensive and outside of our price range.

	Logitech C270 720p	Microsoft LifeCam HD-3000
Megapixels	3	Not listed
Video resolution	1280 x 720 pixels	720p
Price	\$22.95	\$22.29

Table 10 - Camera comparison

### 6.6.2. Raspberry Pi Camera

Considering one of the options for the MCU that controls the camera is a Raspberry Pi, the Raspberry Pi Camera is a good choice since it was designed to be used with the Raspberry Pi. A downside to using this camera is that it will harder to obtain a longer connection between it and the MCU, since it does not use a standard USB wired connection like stated above about web cams. The connection it comes with is very short in length, and will most likely need to be lengthened so it can be set up for a proper filming angle on the bike rack. A benefit from using this camera is that there are libraries directly linked from the product website which aid in ease of implementation.

## **6.7. Light Sensing Technologies**

Our first option for lighting up the bike rack is to implement a technology that senses when it has become dark outside. The downside to these devices is that the lights will be on the whole time that is dark outside and not just when people are there. The upside to these is that we do not have to keep track of what time it is or never need adjustments for when the daylight and nighttime hours change throughout the year.

### **6.7.1. Phototransistors**

A phototransistor is a semiconductor device whose base, when it is hit with infrared light, converts that light into voltage. It is from there that the emitter-collector path conducts. How bright the light it is taking in is determines how much current is flowing. The brighter the light, the higher the current that is produced.

Normal bipolar transistors are also photosensitive, however, phototransistors are made in such a way to take advantage of those effects. The phototransistor is much like a normal bipolar transistor, with the exception that it's base is exposed to take in light. Even when there is no light on a phototransistor, there will be a small amount of current. They can detect wavelengths from the near UV to near infrared range.

### **6.7.2. Photodiode**

A photodiode is a semiconductor device that converts light that shines onto it into current. Photodiodes tend to be the most sensitive to light from 200 nm to 1100 nm, which is sufficient for detecting sunlight. A photodiode can be operated in either of two modes, and the choice of which mode to use should be based on how fast you need it to respond and the allowable amount of dark current. The photovoltaic mode results in the photodiode unbiased and a minimum dark current. On the other hand, the photoconductive mode results in the photodiode being reverse biased and having faster response time. If this were to be implemented, the reverse biased mode would benefit us the most, because we want the lights to be on as soon as they need to be, as off as soon as they need to be. The material a photodiode is important in defining its properties. The Table 11, below, courtesy of Wikipedia, demonstrates what wavelengths different materials are sensitive to.

Material	Electromagnetic spectrum wavelength range (nm)
Silicon	190–1100
Germanium	400–1700
Indium gallium arsenide	800–2600
Lead(II) sulfide	<1000–3500
Mercury cadmium telluride	400–14000

Table 11 – Wavelengths of different materials  
(Courtesy of Wikipedia)

### 6.8. Bicycle Identification System

The idea of using a barcode to identify the bicycles was an initial option as it provided an already familiar concept and ease of implementation. Barcodes identification are very common and are used almost everyday. A positive to using barcodes is the ease of implementation and low cost to produce multiple barcodes, as you only need a printer and simple laminate. However, for outdoor purposes, barcodes become a problem, as printed ink may fade over time as well as the laminate being exposed to weather may deteriorate its effectiveness from protecting the barcode. The vulnerability from scratches and normal “wear-and-tear”. Alongside its outdoor vulnerabilities, in order for barcodes to be integrated into the system would require the user to have to manually position the bicycle to scan the barcode. This degrades convenience to the user experience and may potentially repel users from using the system in the future.



Figure 6.8.1 - Example of barcode placement on a bicycle

Radio Frequency Identification (RFID) has been a popular way of tracking inventory since its creation. RFID utilizes the electromagnetic field (EMF) phenomena in order to transmit data. A reader simply emits an EMF and when the tag is very close by, some as close as 7cm, the readers EMF induces a current in the tag, which then transmits the identification number via the tags antenna to the reader. The reader then processes this information, or sends it to a server to then authenticate. In our system, bicycle

identification would be met with a bicycle tag- housed inside an enclosure connected to the bicycle itself- being connected to the user who rents it, first when they check the bike out, and then when they return the bike, clearing the user for the time allotted and allowing the next person to then rent the bike as well. This identification method is extremely cost-effective, comes to no inconvenience to the user and allows tracking bicycle inventory seamless.

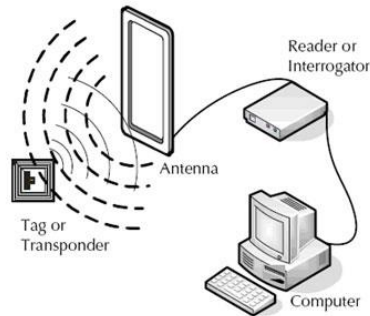

Figure 6.8.2 - An example of data transmission via RFID tag to reader

## 6.9. User Interface

Alas, the tip of the iceberg. The user interface is one of the most crucial aspects of any project, not only this one. This integral component is crucial to the success of the project, as it depends on how users mainly perceive and interact with the system. Just as a website or mobile application, ease of use is the main focus of the UI.

UI's require a lot of thought when designing and producing a system. There are a lot of key factors that come into play when designing them such as cost, size, connectivity, power consumption, processing power and operating systems (if need be), what type of graphics are required, should it be wireless and if so, short or long range and so forth. All these factors affect the user experience, even when it's behind the curtains. It is best to thoroughly run through the UI design process before implementing any further components of the project.

### 6.9.1. Cost

Cost is a huge factor when designing and implementing any kind of project, not just UI's. With cost constraints, come UI constraints. High-end leading technology is expensive to implement in a project, however, it may lead to a smooth and seamless UI. If the price point is too high, the project would never gain traction from investors and wouldn't see the light of day. Tradeoffs are mandatory and the lack of technology may be met with other accessories or details which may balance the UI.

### 6.9.2. Size & Connectivity

Size is another important factor. Depending on the system, it may need to be portable or not, which affect the UI design process and the end product. An Apple Watch UI is going to differ from the UI of an airplane drastically. Also, is the system going to be wireless or

hard wired. If it is wireless, are you going to use short or long range wireless, which also cut into cost and size constraints. If it is a hardwired system, then that means you're hardwired into the power grid, which affects energy costs and may be too taxing on the maintenance costs of the system. If energy costs are not an object, then hardwired systems give leeway to more suitable options, as low-power processors and low-power devices are not necessary.

### *Processing Power*

A lot of UI design can be correlated to the processing power of the system demand. A UI that requires top-level graphics will need more processing power to drive the displays and may even need a separate processor specifically for it, in order to alleviate delay from the main application processor. Processing power is also directly related to cost, as powerful processors cost more compared to their counterparts.

### **6.9.3. User Authentication**

Aside from the RFID tap option, a magnetic card reader provides us with a different option for users to authenticate in the system. A key factor in considering this as an option, is the fact that every UCF student already has a card, making distribution an unnecessary task in implementing this project. Magnetic card readers provide an efficient way of retrieving student information since an abundant of students' information is already loaded on their student id. Majority of magnetic card readers run off of USB 5V, which falls well below our power supply.

From a design perspective, magnetic card readers are really not as big as you see in everyday life. They are actually really small devices with two magnetic stripes facing each other. When a card is swiped, the magnetic stripes pull the information that is loaded from the cards, starting with what is referred to as "a sentinel bit" (refer to Standards). This bit tells the computer where the information is starting from. This is then connected to an integrated circuit which transmits this data to the main processor or server, which then decodes the binary into hexadecimal and then into text if need be. Since the main point of our project is much larger than the scope of a magnetic card, we will not be needing the intricacies to modify its behavior. Although designing and fabricating is more cost effective, it would also take up more time, as we would need to design an enclosure to integrate into our UI. We will then look into the various options for purchasing a reader.

MagTek is the leading brand and offers a dual swipe and bi-directional, meaning that you can swipe the card either way and from top to bottom or vice versa. Being the leading brand, demands a higher price, coming in at around \$45-55. The second option is Square, the popular startup that is attempting to take over mobile payment processing industry (they make up less than 4.9%, but that's still very significant) with their cleverly small designed magnetic card reader. The reader plugs into the auxiliary headphone jack of smartphones and could easily be interfaced with the MCU, if the MCU were an Android or iPhone application. Unfortunately, it isn't so were moving on. Another option is the OSAYDE MS Magnetic card reader offered 3 track dual-reading, and is preloaded with

read software and is plug and play, meaning it can interface with any hardware. It also is bi-directional and can All we need is to be able to authenticate UCF student identification. This also met our specifications for being a low-power as it is interfaced with the MCU via 5V USB.

#### **6.9.4. Display Screen**

The display screen is very important for this project. This is one of the major components that the user interacts with from our system, therefore it is important to choose the correct display screen. By comparing the disadvantages and advantages of each of the two options for display screens, our task at choosing the best one will be easier.

First, let's look at the two possible options for display screens: Cathode Ray Tube (CRT) and Flat panel display. CRT screens were some of the first screens invented to display video imaging. Very popular from the 50's up into the 90's, these display screens saw their day as Flat panel displays began to takeover. One advantage of these displays are their cost effectiveness, as you can acquire one of these for almost next-to-nothing. The major disadvantages are, of course, their size compared to flat panel displays and their energy consumption. With our project being built upon renewable energy and dependent on energy conservation, CRT displays certainly are not a viable option.

Flat panel displays would be our next option, as they're the most common display technology of today and are relatively inexpensive. These displays come in a few options: Light Emitting Diode (LED), Liquid Crystal Display (LCD), and Electronic paper (E-Paper) display. Any one of these options significantly trumps CRT as they come in a variety of shapes and sizes and most importantly, consume far less energy than CRT displays, which of course, is what we want.

E-Paper display is a display that mimics the visualization of black ink on white paper. If you're not familiar with the term, just think of the Amazon Kindle, it has an e-paper display. These displays are low-power and use an interesting method to display to the screen. They're great for outdoor use, as there is little interference from the sunlight onto the screen, as these displays don't depend on light, unlike LED's and LCD's, to display text or images on the screen. One drawback to e-paper displays is they're only available in black and white at a reasonable cost and the multi-color screen options are not economically viable compared to the competition.

LED and LCD screens are the final option to overview. One of the major benefits, and reason why LED/LCD are used in so many UI architectures, is the rapid refresh rate that is offered. This is why televisions and graphically-enhanced UI's integrate these displays. Also, their availability in color is another factor. One drawback, is that they're not as energy efficient if they're constantly running, but in our case, we can control that feature if need be.

One of our primary options was to go with a basic seven-segmented LED screen. The main reason was simplicity and familiarity, even though it's not as aesthetically pleasing



as a color LCD screen. A disadvantage is the limitation of displayed output. Alongside the LED screen would be the requirement of push buttons, which would be used to select various options that the user would need to input in order to complete the use of the system. Other forms of LED screens come with larger segment array, allowing a broader spectrum of output to be displayed which may suit to be viable options.

Another option was to go with a touch LCD screen. This is not only the higher end of the cost spectrum but also the UI spectrum as well. By utilizing a touch screen, the need for analog buttons are eliminated. The aesthetics are also targeted to more of the millennial generation, as they're really only familiar with these UI's due to their smartphones, etc. They have a rapid refresh rate and the option to include a friendly video is also a bonus, as new users can watch this to quickly learn how to use the system effectively. There are multiple LCD modules available at reasonable price, however depending on the MCU chosen will dictate the touch LCD module as it will require the MCU to be compatible with the graphics libraries.

One touch LCD screen module is the RA8875 driver board coupled with either a 4.3", 5.0" or 7.0" touch resistive screen. It is low power, requiring 3-5V with a constant current booster to drive the LCD screen. A major drawback is this system is incompatible with any TI MCU and would require a compatible module from Adafruit.

A second LCD module option is the TI EB-LM4FXX Stellaris Series LCD Boosterpack. This system is low power as well, requiring 3.3V and has plenty of memory, coming in at 256kB flash and 32kB RAM. Cost is also a factor and this boosterpack could be a cost effective option for the project.



Figure 6.9.4 - TI Stellaris LCD demo  
Courtesy of TI\* (pending approval)

The following table summarizes the comparison of the various display screens available on the market.

Display/Spec	E-paper	LED segment	LCD	Touch	CRT
Power	<3V	3-5V	3-5V	3-5V	High DV/120AC
Resolution	Low	Low	Low	High	low
Refresh Rate f/s	low	60	60-120	60	<60Hz
UI Rating (1-5)	3	4		5	1

Table 12 - The comparison of the various available display screens

## 6.10. Wireless Communication

For this project, it is required that we have a wireless connection in order to transmit data to authenticate users as UCF Students. Another reason is the system is to be designed with wireless communication is so it does not require any hardwiring into the grid, making the system versatile when it comes to location placement. Therefore, any hardware options are out and we must evaluate the wireless options available: WiFi, Bluetooth, and ZigBee. These are the most popular wireless options as they all have disadvantages and advantages regarding cost, implementation, security, bandwidth, interference, power consumption, and, last but not least, range.

### 6.10.1. WiFi

Standard WiFi transmits at 2.4GHz with newer modems transmitting at 5GHz. The main difference between the two is wavelength, making the 2.4GHz more adaptable to its environment as the waves can maneuver around objects better than its 5GHz counterpart. This makes it a very popular option. One major drawback to WiFi, compared to the others, is it is an energy hog, especially if it is constantly running. Security is somewhat of a concern, however the majority of the wireless MCU solutions that now exist, offer 128 to 256-bit encryption and is now becoming standard protocol for the Internet-of-Things (IoT) wireless solutions.

Making the microcontroller able to connect to the internet via WiFi would allow the time to be updated in real time, with no need for adjustments. This would make it easy for instances such as daylight savings time, because no human intervention would be needed to keep the clock accurate. A fairly powerful microprocessor would need to be used to make WiFi a viable option.

One disadvantage with using WiFi is that it will use a lot of the microcontroller's resources. Another drawback, however not uncommon, is interference. Interference can occur with all wireless communication, not just WiFi, and occurs from devices emitting EM waves such as "microwave ovens, cordless phones, Bluetooth devices, wireless video

cameras, outdoor microwave links, wireless game controllers, Zigbee devices, fluorescent lights, WiMAX and so on". [6]

### **6.10.2. Bluetooth**

Bluetooth is another form of wireless communication that uses EM waves which connect at a shorter range than WiFi signals. By today's standards, it's a household name and its footprint is very prominent in the IoT world. There are multiple forms of Bluetooth: BR/EDR (basic rate/enhanced data rate) and low power. BR/EDR are the most common form in bigger devices and low power usually found in wearable devices such as fitness bands. Bluetooth has an advantage over WiFi as it's not such an energy hog, however, the advantage comes at a cost: range and transfer rate. Typical Bluetooth has a maximum range of up to 10 meters vs WiFi's 95 meter maximum. Another drawback is transfer rate, limited to 1Mbps vs WiFi's 54Mbps. Since typical Bluetooth allows multiple devices to talk to each other, we will not really be needing this option, as we need to be able to connect to a remote server to authenticate. Maybe in the future, an Android/iPhone application can be used in tandem with Bluetooth to pair and authenticate users, however that leads us to another technology being used for the same purpose.

### **6.10.3. RFID/NFC**

As stated previously, RFID/ NFC (Near Field Communication) is an efficient method to identify and authenticate users to the system. One way is through a tag, which a chip is embedded that has a specific number associated with it. Another way is through smartphones, which many are coming equipped with RFID tags/readers in them. A prime example is Apple Pay, where users have their credit card information stored on their phone. All users need to do is simply tap their phones on the RFID readers in store, their credit card information is transmitted, and the payment is executed. It's possible to design an iPhone/Android app where users need to first fill out their student information. The app will connect to the school server and verify the student data. From there, all students would need to do is tap an RFID reader at the station and they would be authenticated already, no need to interact with a touch screen etc. It would make for a smoother user experience, however, mobile applications are out of our current range of knowledge.

One drawback to be noted is that everyone that is in our market may not own or possess a working smartphone that is NFC compatible. This could severely limit and possibly deter valued users away from our system, if this was the only option. Also, tags could be an option for memberships, however that does come with an initial cost before user purchase, increasing unnecessary overhead. It also is something additional for users to lose, which the idea of cost replacement may drive them away from the system, as the market is college students who don't have much capital to begin with. Table 13 summarizes and compares the various wireless methods.

Method-> Specification	RF/NFC	Bluetooth	WiFi
Max Range	3m	100m	100m
Frequency	125kHz-5GHz	2.4GHz	2.4-5GHz
Communication	1 and 2 way	2 way	2 way
Data rate	106, 212, 424 Kbps	22Mbps	144Mbps
Application	Payment, inventory, identification	Communication between peripherals	Wireless internet

Table 13 – Wireless Methods

## 6.11. Embedded System

The following section will overview the possible embedded system options for the main control unit and the security system. It is important choose the microcontrollers wisely as you run the risk of choosing too small of an MCU and may run out of memory or too big and is less cost effective on the system.

### 6.11.1. Central System

When choosing a microcontroller, there are endless options to choose from. The main consideration when researching a microcontroller unit (MCU) is the architecture. There are two types of architectures that MCU's are built on: Harvard and Von Neumann. Since this isn't a microcontroller project, the bulk of the details aren't necessary, however it is noted that Harvard architecture is the most commonly used today, due to its parallel processing speed in which it accesses memory. It is almost too important to keep in mind the programming language in which you will need to code the MCU. All MCU's can be programmed using assembly, C, C++, Java, Pascal, and a few others to give an example. Assembly, C and C++ are the most common, especially amongst EE's. Assembly allows the programmer access to control specific registers, useful when a custom function needs to be created and/or a subroutine made. This allows direct manipulation of the stack, which is useful but also very time consuming.

A good place to start are some of the more common MCU's used such as Texas Instruments (TI) MSP430 Family, Advanced Reduced Instruction Set Computer (RISC) Machine (ARM), Amtel Family and so forth. Since we want to use a Harvard Architecture, we can start weeding out our options from there. TI's MSP430 implements Von Neumann so that one is not an option. Another key factor in our decision making for our central MCU is memory capability and multiple peripherals.

One of them was the TI Tiva C Series TM4C123G. From the looks of it, it had all the memory capability that we needed. 256KB of flash, 32KB SRAM, 2KB EEPROM (which we don't really need but could be useful). Alongside the memory, the clock speed, 80MHz is plenty of processing speed to ensure fast output to the LEDs, making the user experience fast and easy when interacting with the system. However, the only downside to the Tiva is that it isn't wireless which would require us to compliment it with a wireless module.

Another option from TI was the CC3200 SimpleLink, Wifi and IoT (Internet of Things) solution micro-chip. From the looks of it, this is a one-stop shop kind of MCU. It comes WiFi certified, an ARM Cortex M4 Core at 80MHz, up to 256kB Flash memory, Hardware Crypto Engine, 1 SPI, 1 I2C and much more. It also comes with a 40MHz and 32.768kHz crystals for the clock sources, and multiple LPM's. One of the only drawbacks is that this MCU only has one SPI port and it may be needed from our project for a few more.

A third option was an MCU from Amtel SMART SAM S Family. These MCU's can run up to 300MHz with up to 2MB of Flash Memory and 383kB of SRAM. Multiple SPI, I2C, High-speed USB and various communication peripherals make it an intriguing option. It's low-power demand is significantly attractive, as that fits our requirements as well. The only drawback is it isn't wireless unlike the TI SimpleLink, and will require an additional wireless mcu to fulfill our wireless requirement. This may not be a viable option due to cost.

MCU/Specifications	TI Tiva	AMTEL	TI CC3200
Power	3.3V	3.3V	3.3V
Clock speed	80MHz	300MHz	80MHz
Wireless	External mod req.	external module req.	WiFi
RAM	32kB	383kB	-----
FLASH	256kB	2MB	256kB
Peripherals	multiple	USB, SPI +	SPI
I2C	4	1	1
IDE	Code Composer		Code Composer
LPM	4	4	4

Table 14 – Comparison of MCUs

### 6.11.2. Lighting & Camera System

The MCU will need to be capable of handling both the lighting and the camera systems at the same time. It will be prudent for the MCU to be able to get the information from the camera saved efficiently to the external hard drive. The MSP432P401R is one choice of MCU for the lighting and camera systems. It would meet our low powered requirements, considering this MCU was designed with that in mind. It only consumes 90 microA/ MHz while active and consumes 850 nA in LPM3 with the RTC running, and the ARM-Cortex M4F CPU runs at a frequency of up to 48 MHz. The RTC is a useful feature for us if we plan on going with the motion sensor option for the lighting system functionality. With 84 GPIO, it would have more than enough room to attach any peripheral devices to it.

Another option is the CC3200 which is from TI's SimpleLink line and is useful for wireless connectivity. This would be particularly useful if we decide to update the time

with WiFi, which would give us the added benefit of being able to count for daylight savings time. We would also be able to send video camera footage to a computer instead of having to use an external harddrive. This MCU has 27 GPIO pins. While not as many as the pins in the other option, it is still plenty for our purposes

Table 15 below gives a side by side comparison between the choices.

	MSP432P401R	CC3200
Power Consumption (Active)	3.7 V, 48 uA/MHZ	3.6 V, 278 mA max
Power Consumption (Low Power Mode)	3.7 V, 850 nA	3.6v, 250 uA
Number of GPIO Pins	84	27
Frequency	48 MHz	80 MHz
Wireless	no	yes
RTC	yes	yes

Table 15: MCU comparison

### 6.11.3. Time Keeping Methods

Time will need to be kept in some form if the lights are turned on with information from the motion sensor. The point of implementing a time keeping method, is to be able to tell when it is nighttime outside, thus deciding when the lights need to be turned on. The pros and cons of using the motion sensor paired with a time keeping method will be weighed against using a light sensing technology. The final choice between the two will be based on what best fits our design specifications and restraints. The possibility of using WiFi to keep time for the lights is discussed previously in section 6.8.1, where it was also examined for other parts of the project.

#### *Real Time Clock*

A real time clock is a small, cheap device that may be connected to the pins on a microcontroller. The time will need to be initially setup. An accurate start time can be obtained by setting it up via WiFi or Ethernet. I2C will need to be set up on the microcontroller to allow communication between it and the RTC. It must be kept in mind, however, that RTCs have a tendency for the time to become inaccurate fairly quickly, so adjustments may need to be made from time to time. Another disadvantage to using a RTC is that it does not directly account for daylight changes throughout the year, so code would have to be implemented to account for that, which may be tricky.

### 6.11.4. Motion sensor

One option for initiating powering on the lights is using motion sensor in conjunction with a RTC, to notify when somewhere is there and when it is nighttime. The camera will need to be activated this way. A benefit to using this for the lights, is that a motion sensor will be already implemented for the camera, so it will not be anything additional in that sense, and the cost of a RTC is minimal. The most prominent type of motion sensor on

the market is a passive infrared (PIR) sensor. It is called “passive” because the sensor itself does not emit or generate energy to do its job, instead it detects the infrared radiation that is either emitted or reflected by an object. It is specifically looking for changes in infrared radiation occurring in its surroundings.

The downside of using this method for the lighting system is that we will need to use the RTC clock, which can be fairly inaccurate. The main issue will be finding a RTC that does not have a large amount of error. Also, if this method is used for the lighting system, it will need to be controlled by the MCU. This will give the MCU more tasks to do, so we would need a MCU that is capable of doing a few tasks at once.

The sensor consists of two slots that are both made out of material that is sensitive to infrared. When the sensor is inactive, it senses only the ambient infrared. However, when a person passes one of the slots, thereby the sensor sensing a change in infrared radiation, a positive differential change occurs between the two slots. A negative differential change occurs when the person passes by the second slot.

It was difficult to find a motion sensor that had copious amounts of information listed for it. Not matter what the choice is, plenty of testing will need to be done to determine that it is receiving the right current and to determine its sensing range. Table 16 details the information known about the two motion sensor choices in a side-by-side comparison.

	PIR Motion Sensor	PIR Motion Sensor (JST)
Power Consumption	5v-16v, current not listed	1.6 mA at 3.3v
Sensing Range	20 feet	Not listed
Sensing Radius	120 degree cone	Not listed

Table 16 - Motion sensor comparison

## 6.12. Software Development Environments

As previously stated, MCU’s can be programmed in a number of programming languages. The best option for us is C for a few reasons. One being that many companies and products use C as a standard programming language and modern compilers can translate into effective assembly anyways. Assembly itself is useful when need be, such as creating subroutines or when you need to access specific registers to manipulate the stack but it’s more tedious and time consuming.

Once the programming language is chosen, it’s necessary to choose an Integrated Development Environment (IDE) to code your program. For this project, we will need an IDE that supports ARM and C together. There are a few IDE’s to choose from such as: DS-5 Eclipse, Crossworks, Keil, and Code Composer Studio from TI. Depending on the financial constraints, certain IDE’s will require a license, which may come at a cost.

Since UCF uses TI MCU’s in their labs, Code Composer Studio is available at no cost to the students, making it a suitable choice. CCStudio is limited in its free software version, however for our design, it poses no threat to drawback or delay. Keil IDE is supportive

on all MCU brands and is marketed as user friendly. DS-5 Eclipse is an open source IDE (free) and is specifically geared at ARM Cortex-A based devices. [8]

For our project, we will opt with TI's Code Composer Studio, as the licensing has already been purchased for us and the software is already downloaded in the design labs computers. The benefit of this IDE is that TI developed it with the intent of optimizing the C/C++ compiler and debugger, so the necessity of using assembly is minimal. Alongside, the easy UI and familiarity allows us to smoothly develop the program without time taken to learning a new landscape.

### **6.13. Cloud Solutions**

In order for the system to authenticate users, it must be connected to some kind of server in order to verify the incoming data that it is receiving from users. There are a few methods we can choose from in order to do this. The most obvious is to connect to the UCF database through its own wireless connection to authenticate, however this being a proof of concept project, there is no need for UCF to hand the keys. In order to demonstrate this behavior we can either create our own server, use a dummy server, or connect to a cloud.

Creating our own server is an interesting option. In order to do so, we would need to know the required space that all the data would require for all UCF students that are currently enrolled and also, for the students in the upcoming years to be added to the system. Also, we would need components to connect wirelessly, via a router, and a central location to place all the servers. For the project purpose, we would only need a small server to mimic this implementation, but we're already under financial constraints and this option is not that demanding to showcase our skills so we're going to bypass it.

The second option is setting up a dummy server, which can be implemented by using an old computer. An old Mac Mini was available to us for free, which had plenty of memory space for the project and already has all the wireless components built in. All it would take is to set up a connection between the two systems.

The third option is to connect to a cloud service (also known as a host), which would require no additional hardware on our part, only a wireless connection. A suitable option is Parse, Facebooks (driven by Amazon Web Services) version of cloud computing for mobile application developers. Through family connections, an account was made available for us at no charge. This is a huge advantage as cloud services can cost anywhere from \$10 to the 10's of thousands depending on storage demand per month. It would provide a simple solution, to store student data for authentication and also can log in and out times, which is useful once the system is setup to determine other statistical data about users and locations.

---



## 7. Project Structural, Hardware, Software Design Details

The following section will overview the final selections of all the researched components and the design details of the project.

### 7.1. Overview Block Diagram

Our system is divided into four main groups:

- Power System (Photovoltaic Solar System, Charge Controller, Battery),
- Power Distribution System (DC-DC, DC-AC, Power Protection),
- Application System (Lighting System, Security Camera, Motion Sensor),
- Embedded System (Microcontroller, Digital Locking System, Magnetic Card Reader).

The following block diagram is generated for the whole system which combines all the groups together as a whole system. For designing purpose, each of these blocks will have its own block diagram to further show detail of the functionality for each component and how it can affect the performance for the system as a whole.

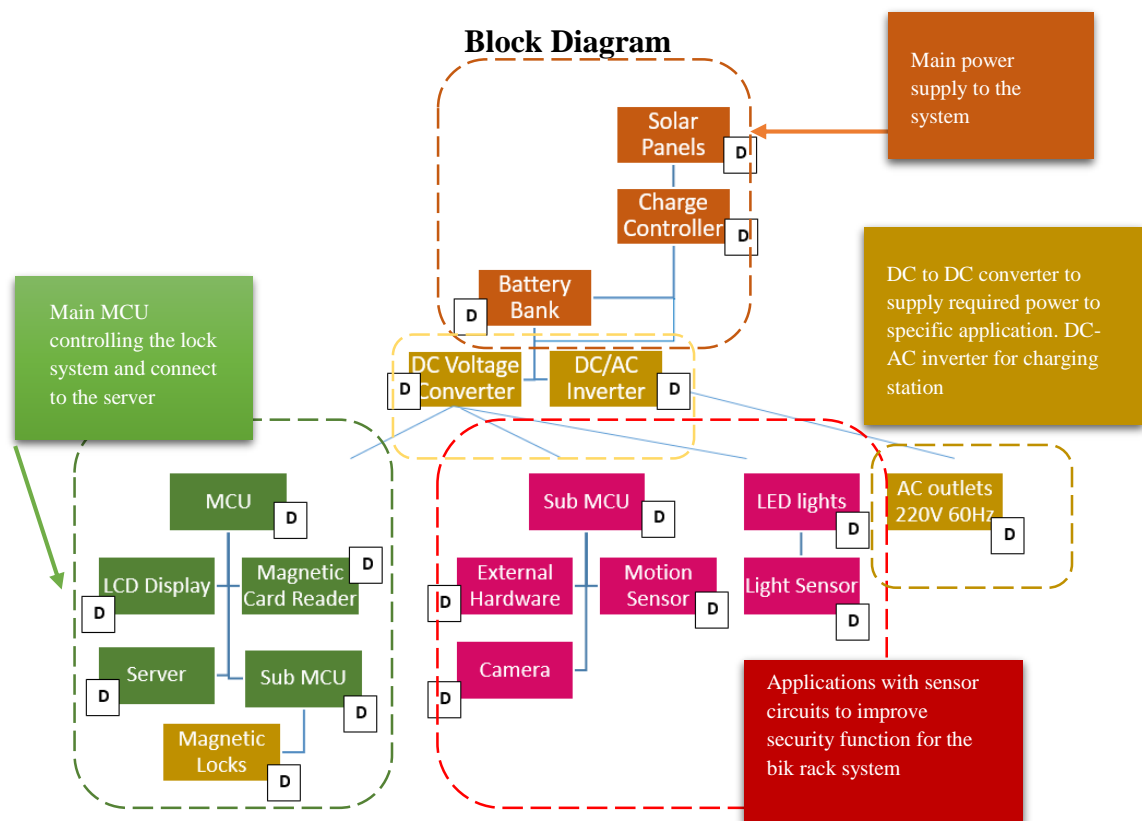

Figure 7.1 - Hardware Block Diagram and Engineering tasks

**NOTE**

- Thai Pham
- Nha Nguyen
- Daniel Adarme
- Christine Erwin

- T** To be acquired - meaning the block will be purchased or donated
- A** Acquired - block has been donated or purchased
- R** Research - block design approach is being investigated
- D** Design - block is currently being designed
- P** Prototype - block is currently being prototyped
- C** Completed - block design is a finished prototype

**7.2. Structural Design**

The proposed structure will entail a bike rack, with mechanical, electronically controlled locks, a roof with solar panel(s) to provide shelter, and the touch screen interface as the main access point for users. The structure will also include lights for post-daylight operation and security camera to monitor activity. Figure XX and Figure XX illustrate this below.

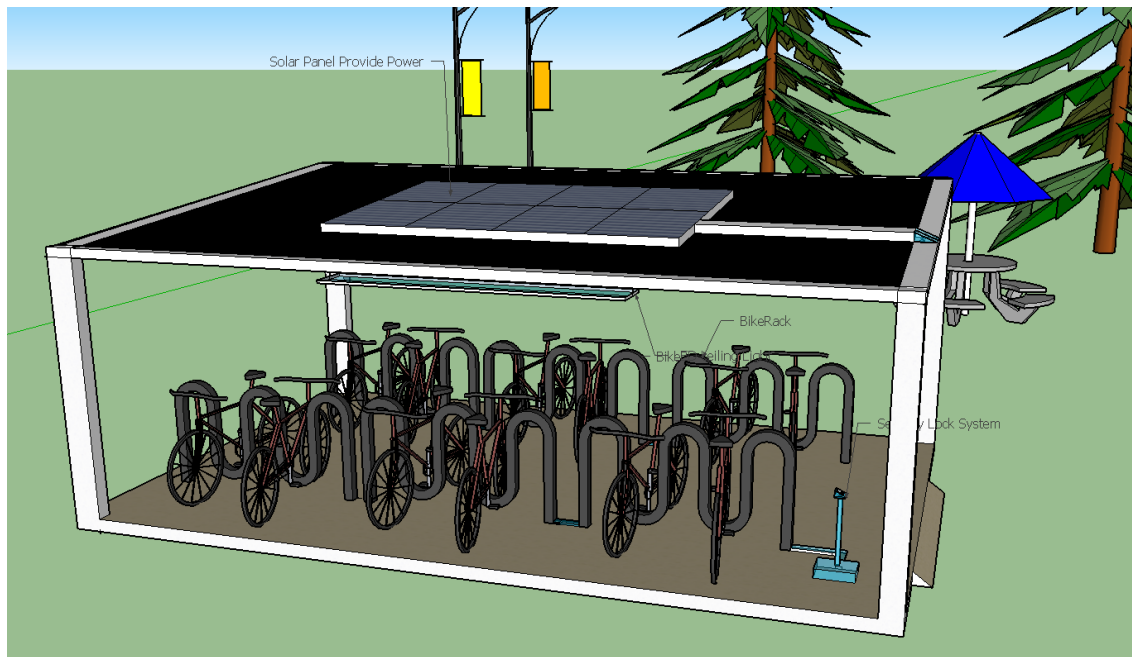

Figure 7.2.1 – Structural Design

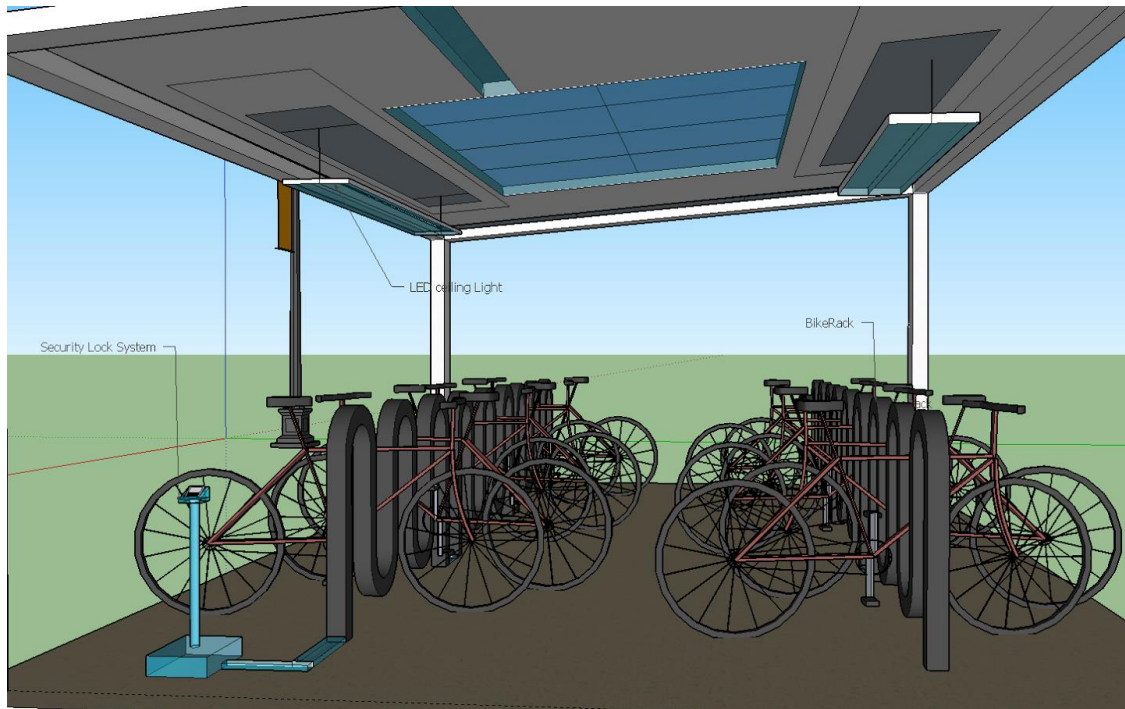

Figure 7.2.2 – Structural Design

For our actual build-out, we will only be representing a single unit and will not building out a multiple bike rack. However, we will be building the roofing structure, the lighting, security camera, and user interface via touch screen.

### 7.3. Hardware Design details

The following section will discuss the hardware design details such as PCB, power system, schematics and specification/requirements.

#### 7.3.1. Power System

The main component to be designed in the power system is the charge controller. This device is also the main controller for the whole power distribution. As being defined in the previous section, charge controller is the control gate which has the ability to control the flow of charge flowing between the solar devices to the battery storage system. It is critical to have a charge controller that can not only achieve the maximum power absorption from the solar devices but also protect the battery storage system.

#### *MPPT Charge Controller Block Diagram*

The charge controller block diagram is designed in the diagram [] below. This design is based on the structure of the MPPT Charge Controller PMP7605 of Texas Instrument. Since our system over all power is 12V, the selections for the photovoltaic devices, battery storage system, and loads are on based on the rating value of 12V. This block diagram has not been fully completed since the power protection system block has not been added. The actual and final blocks will be completed upon the design of the over all bike rack system.

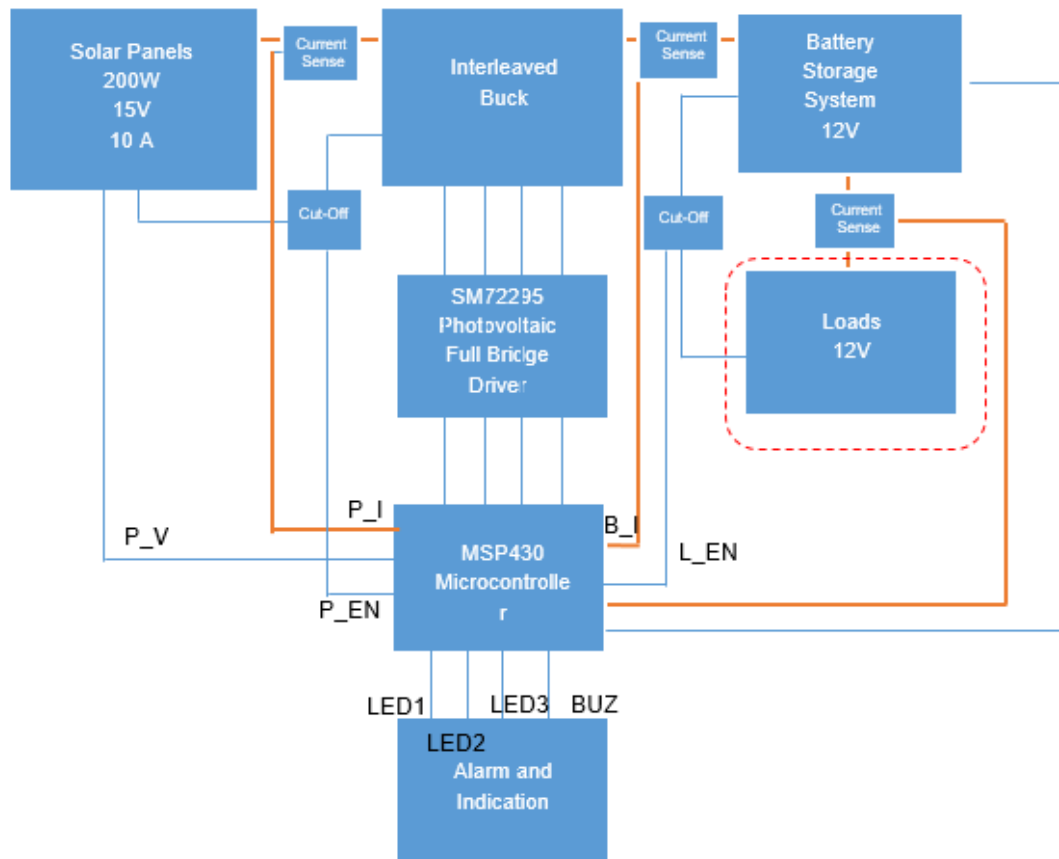

Figure 7.3 - MPPT Charge Controller Block Diagram

### 7.3.1.1. Charge Controller

The schematic design is based on the reference design from TI (Texas Instrument)  
 The figure 7.3.1.1 is the Power Stage reference design for the MPPT Charge Controller

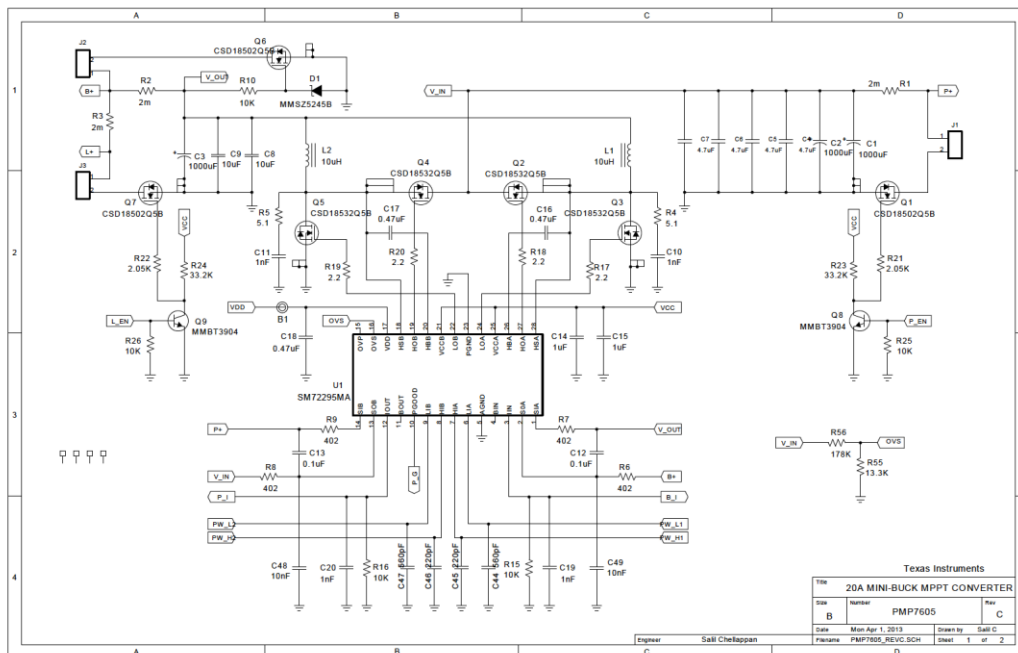

Figure 7.3.1.1 - Power Stage reference design for the MPPT Charge Controller

The figure 7.3.1.2 is the Control Stage reference design for the MPPT Charge Controller

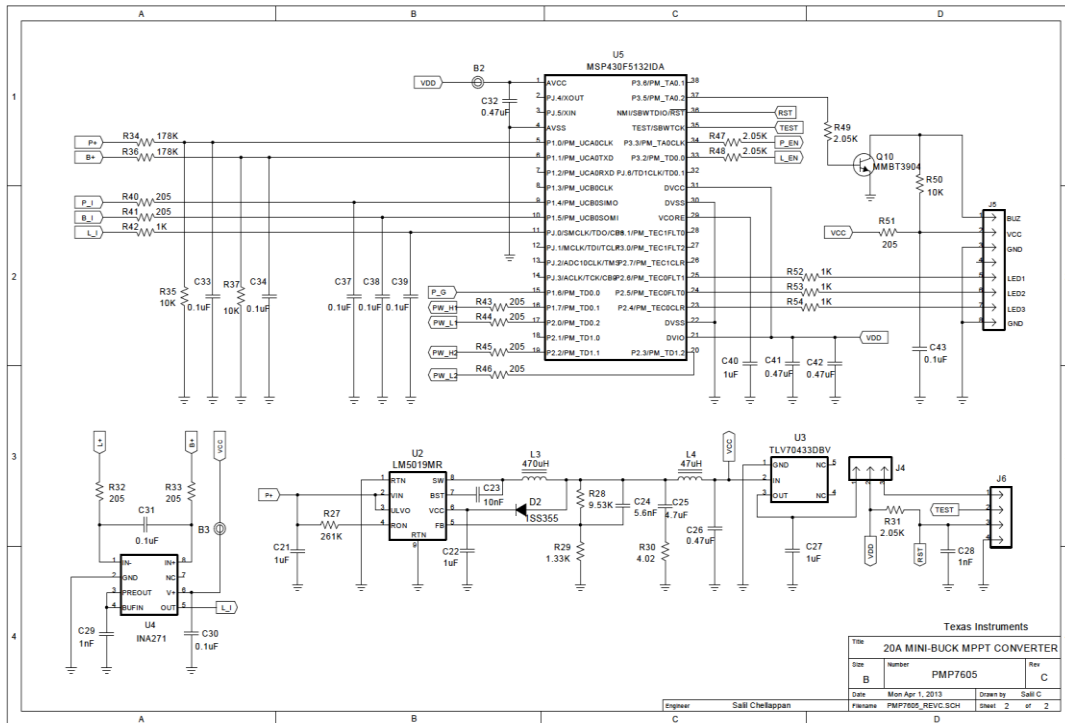

Figure 7.3.1.2 - Control Stage reference design for the MPPT Charge Controller

### **7.3.1.2.Charge Controller Power Stage Design**

After the process of absorbing the solar energy power the, the photovoltaic devices convert those power into electrical direct current and send into the system. At this stage, the current flow from photovoltaic devices, battery storage system, and load will be sensed and the data will be fed into the logic control device (which will be further explain in the control stage). Once the power signal is fed back from the logic control stage to this stage, the power station will have the ability to stop and cut off the flowing of the current. One of the main components in this stage is the Texas Instrument Photovoltaic Full Bridge Drive SM72295 chip. This device has the ability to drive four N-channel MOSFET which control the stage of the current going to the system. Since the reference design of this charge controller is dedicated to the 12V/24V system, there is no necessary to change any component in this design due to the fact that it matches our specification requirement for our power system. The change in component can result some power efficiency from the original stage which is the factor that we want to prevent from.

#### *The Photovoltaic Full Bridge Drive SM72295 Chip*

In reference design, the full bridge driver TI SM72295 chip has been chosen to be the control center of the TI-012 MPPT charge controller power stage. This is the MOSFET driver, with the ability to drive 4 N-Channel MOSFETs in full bridge configuration mode. The peak current of the drivers reaches up to 3A for fast efficient switching. Also, the drivers provide integrated high speed bootstrap diodes. Current sensing is provided by 2 transconductance amplifiers with programmable gain and filtering to remove ripple current to provide average current information to the control circuit. There is an externally programmable input over the voltage comparator provided which is used to shut down the all the output. The PGOOD indicator prevents the driver from operating when the VCC is too low (this is used for under voltage lockout).

Pin 1 through Pin 14 has the function as receiving in the sensed current input information into the chip which will be amplified through the transconductance amplifier. The image shown in figure 7.3.1.3 is the design process schematic which is used to demonstrate the process of chi.

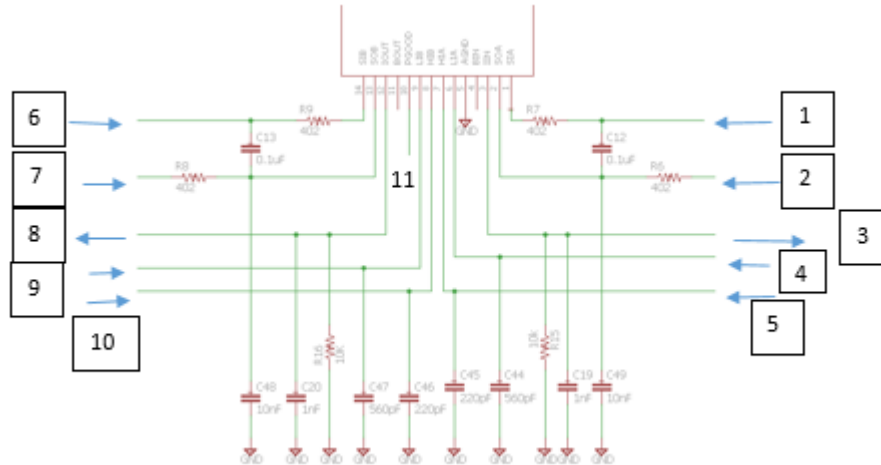

Figure 7.3.1.3 – Logic Process of Data Collecting of the SM72295

Pin 1	Voltage at the higher end of the current sense resistor located near the battery terminal
Pin 2	Voltage at the lower end of the current sense resistor located near the battery terminal (which is the positive battery terminal voltage)
Pin 3	Output for the battery current sense transconductance amplifier
Pin 4	At this pin, the lowside control input is fed from the control stage (MSP430)
Pin 5	This is the high side control input which is fed from the control stage (MSP430)
Pin 6	Voltage at the higher end of the current sense resistor located near the solar panel
Pin 7	Voltage at the lower end of the current sense resistor located near the solar panel
Pin 8	Output for the battery current sense transconductance amplifier
Pin 9	At this pin, the lowside control input is fed from the control stage (MSP430)
Pin 10	This is the high side control input which is fed from the control stage (MSP430)
Pin 11	Open drain output with an internal pull-up resistor to VDD indicating VCC is in regulation. PGOOD low implies VCC is out of regulation.

Table 17 – SM72295 Pin Configurations

*Power MOSFET selection*

Based on the given reference design, there are a huge involvement of power MOSFETs which play a big role in making the circuit logically working. The choice for the power MOSFETs are the N-channel 40V, 100A (CSD18502Q5B) and the MOSFET N-channel 60V, 100A (CSD1853Q5B). These MOSFETs protect the battery reverse power flow as well as the panel reverse power flow. According to the manufacturer’s data for these types of MOSFET, they have ultra low Qg and Qgd and low thermal resistance. For the

electrical capability, these MOSFETs can handle voltage range around 40V and above. This is critical because it can protect the system from the open circuit.

#### **7.3.1.3. MPPT Charge Controller Logic Control stage**

This is the stage where most of the sensed voltage and current information being interpreted and controlled in complex algorithm. The main control component in this stage is the MSP430F51321 Microcontroller manufactured by TI. Since the charge controller has the maximum point tracking function, the chosen microcontroller will be programmed by external hardware with the provided code.

For this logic control stage, a specific algorithm was designed by TI engineers to ensure the working condition of the charge controller can achieve the maximum efficiency. The algorithm is based on the “perturb and observe” algorithm for MPP tracking.

The data informations from the power stage are sending to this stage to be actively controlled by the microcontroller which takes the voltage input and current input data and find its maximum point. This method is effective because it utilize the maximum power. Also, if the values of voltage from the supply source exceeded the needed values, the controller will convert it into useful current.

#### **7.3.1.4. Bias Supply Power Stage.**

This is the stage where the powers which are generated from photovoltaic solar panel being converted to a bias power supply for the MSP430 microcontroller and SM27922 mosfet driver.

In this stage, the main component is the LM5019MR which is the 100V, 100mA constant on-time synchronous buck regulator. This buck regulator will perform a stepping down task for the power supply when there is a presence of the power from the photovoltaic panels.

##### **3.1 The LM5019MR 100V constant on-time synchronous buck regulator**

The LM5019 is a 100-V, 100-mA synchronous step- 1• Wide 7.5-V to 100-V Input Range

The LM5019 is a 100V, 100 –mA synchronous step down regular with integrated high-side and low-side MOSFETs. The constant-on-time (COT\_ control scheme employed in the LM5019 requires no loop compensation provide excellent transient response, and enables very low step-down ratios. The on-time varies inversely with the input voltage resulting in nearly constant frequency over the input voltage range. By connecting the

#### **7.3.1.5. Power Distribution System Design**

Since the bike rack system has different components whose voltage and current value are different, it is essential to have a separate power distribution system that can handle these loads individually. We want to design a power distribution system that can provide the required rating voltage, limit the currents, and improve the efficiency for the power system.



Without the power distribution circuits, the loads can be damaged and it can leads to the failure of the system overall. System Input Power: (Power Supplied by the Battery)  
13.5VDC – 14.5VDC below is the block diagram of the power system for the bike rack

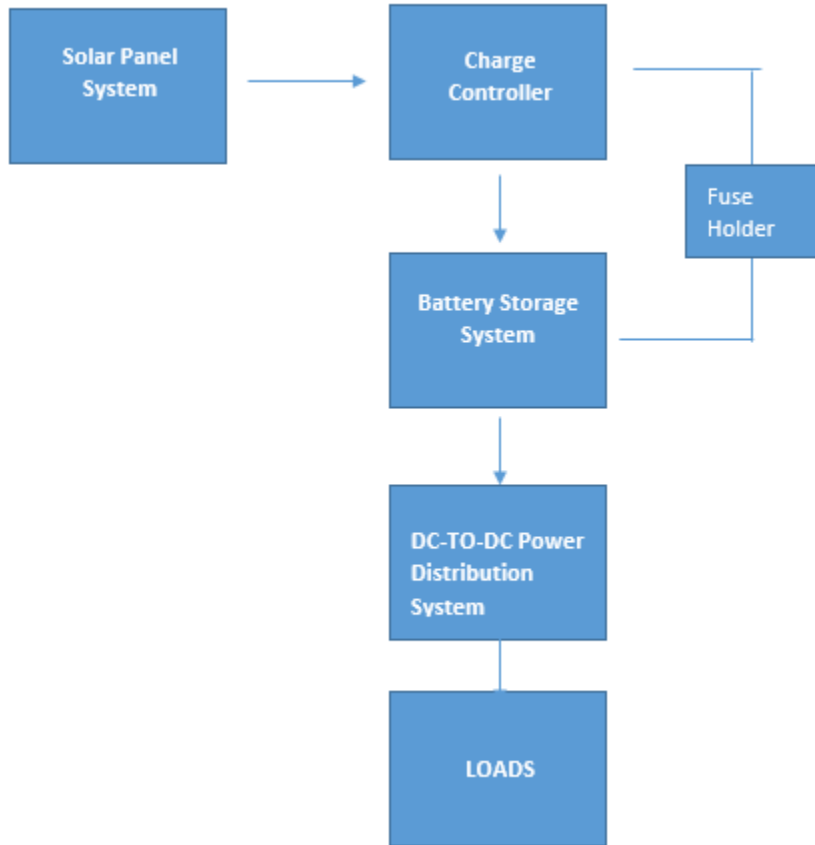

Figure 7.3.1.4 Power Distribution Block Diagram

Texas Instrument has provided an useful software that can design a circuit based on the given specification. The software design is Webench Tool Design. This is completely functioning software that allows user to design power distribution circuit from one single input to multiple loads.

#### *System Loads Identification*

We identify each component in our system list that requires power supply directly from the battery before we start our distribution design. Each component has a unique operating rating current and voltage value to be considered.

The table 18 below is the list of the loads that require power supplying from the battery.

Battery Power	14.5~14.9		
	LOAD NAME	Max Voltage	Max Current
1	DC-AC Inverter	12V	10A
2	Solenoid #1	12V	3A
3	Solenoid #2	12V	3A
4	SINGLE POLE RELAY	12V	10A
5	MCU for Christine	3.7V	0.05A
6	LCD screen for DAN	3.3V	0.75A
7	MCU for DAN	3.3V	0.3A
8	Magnetic Card Reader	5V	0.7A
9	RFID Reader	5V	0.7A

Table 18 - List of the loads that require power supplying from the battery

All the components are selected equal to 12V or under due to the 12V design that we have initial.

Since there are some component requires less than 5V, we want to design the desired DC to DC convert that can meet those requirements.

Each of the loads has the voltage ripple = 5%

*Power Distribution System Block Diagram*

The block diagram in the figure 7.3.1.5 shows the optimized system of the power being distributed through all the loads. Each of the DC-DC converter acquires TI product to match its max performance.

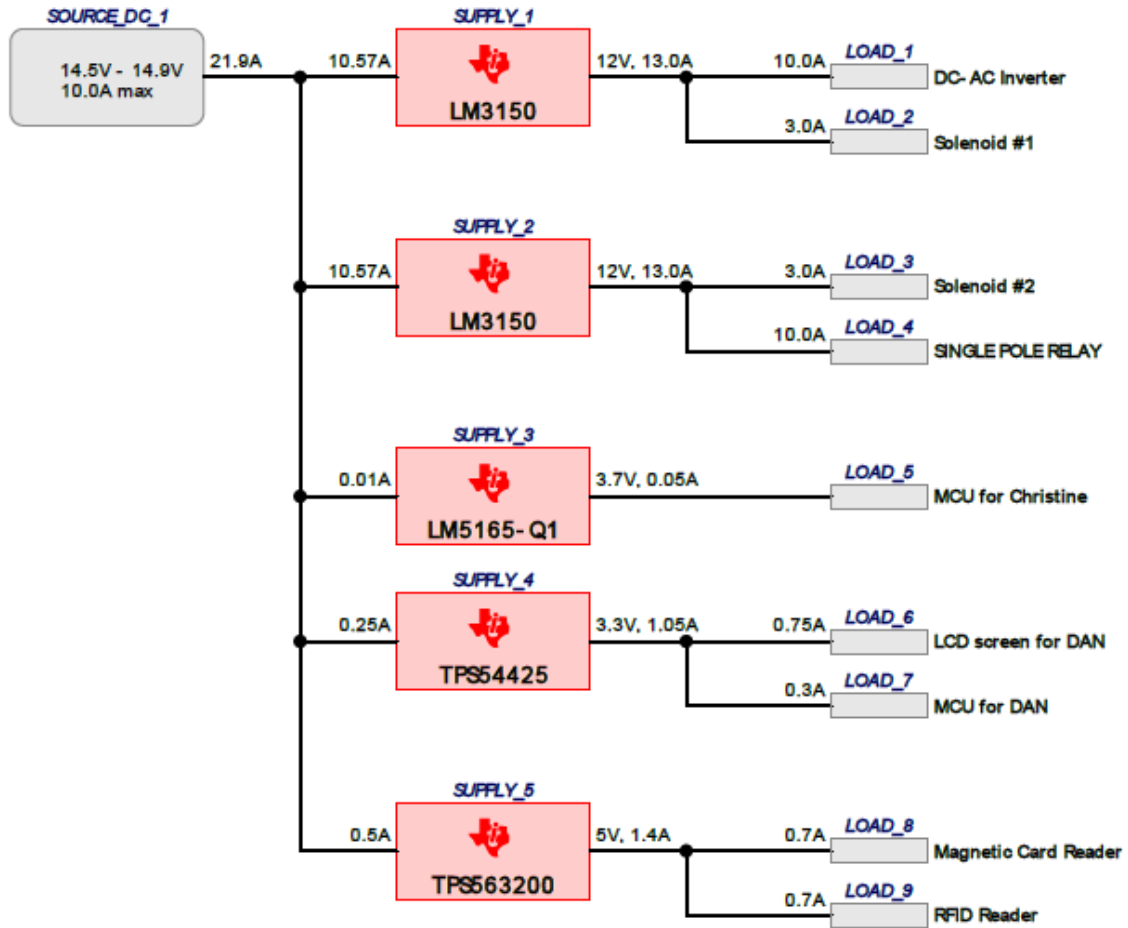

7.3.1.5 - Block Diagram of the Internal Power Distribution System

Project Summary

- |                                   |                       |
|-----------------------------------|-----------------------|
| 1. Total System Efficiency        | 98.89%                |
| 2. Total System BOM Count         | 64.0                  |
| 3. Total System Footprint         | 2.614kmm <sup>2</sup> |
| 4. Total System BOM Cost          | \$16.68               |
| 5. Total System Power Dissipation | 3.622W                |

*Supply #1 and Supply #2*

*DC-To-DC Converter from 12V-to-12V with current limited at 13.0A*

In the first four loads: DC-AC Inverter, Solenoid #1, Solenoid #2, SINGLE POLE RELAY, they all require 12V rating voltage to operate. The DC-AC Inverter for the electric bike and the Single Pole Relay for the motion sensor require current at 10A. The solenoid #1 and solenoid #2 require 3A each. The first circuit design schematic will be

convert the power current from the battery to regulated 13A circuit as the Block Diagram in figure 7.3.1.6

In the figure 7.3.1.5 Block Diagram of the Internal Power Distribution System, the supply\_1 and supply\_2 has the same schematic design, we will only show one circuit

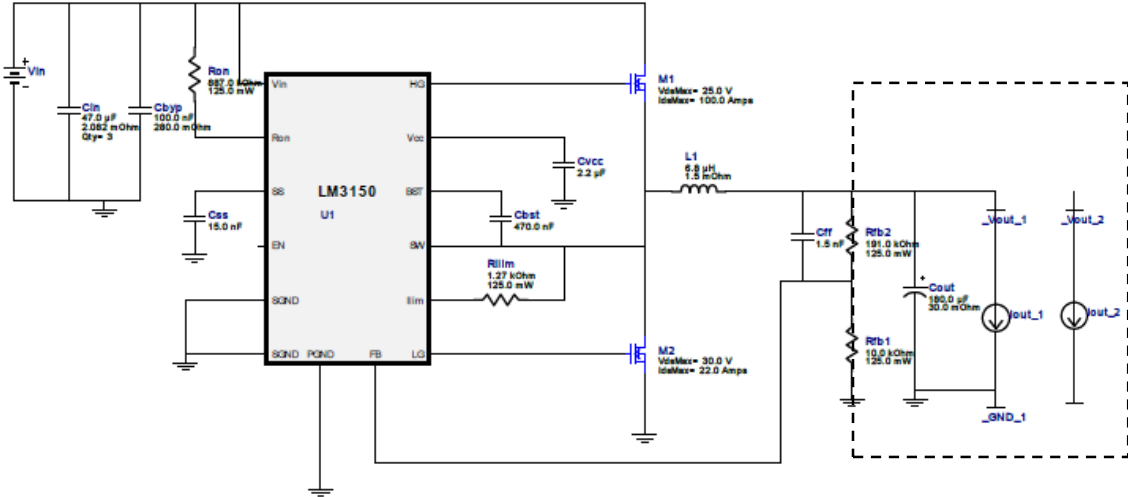

Figure 7.3.1.6 - Schematic Design for the DC-DC 12V 13A output Circuit  
The Input will be 14V supply from the deep cycle battery to to the LM3150 and the output terminal will be connected to load#1 (the 100W DC-to-AC inverter ) and load #2 (the 24W solenoid #1)

### Design Inputs

#	Name	Value	Description
1.	Iout	13.0	Maximum Output Current
2.	VinMax	14.9	Maximum input voltage
3.	VinMin	14.5	Minimum input voltage
4.	Vout	12.0	Output Voltage
5.	base_pn	LM3150	Base Product Number
6.	source	DC	Input Source Type
7.	Ta	30.0	Ambient temperature

Figure 7.3.1.7 - Design Input of the circuit supply #1 and supply #2

### *The LM3150 Intergrated Circuit - Synchronous Step-Down*

The supply #1 and supply #2 circuit has The LM3150 SIMPLE SWITCHER controller as the main component to perform the step down functionality. Synchronous Step-Down controller is an easy-to-use and simplified step-down power controller capable of providing up to 12 A of output current in a typical application. Operating with an input voltage range of 6 V to 42 V, the LM3150 controller features an adjustable output voltage down to 0.6 V.

*Supply #3 DC-To-DC Converter from 12V-to 3.7V with current limited at 0.05A*

This circuit design functions as the step down regulated voltage and current circuit that when the input (which the power supplied from the battery) will be stepped down and regulated at 3.7. The output terminal of this circuit will be supplied directly to the MCU that the controls application (the motion detection sensor, the security camera, and the light) of the bike rack system.

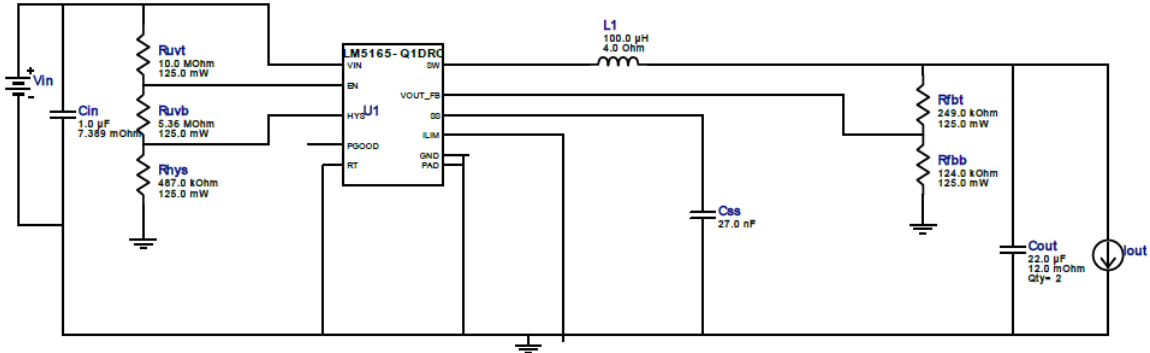

Figure 7.3.1.8 - Schematic Design of the Supply #3 Circuit

### Design Inputs

#	Name	Value	Description
1.	Iout	50.0 m	Maximum Output Current
2.	VinMax	14.9	Maximum input voltage
3.	VinMin	14.5	Minimum input voltage
4.	Vout	3.7	Output Voltage
5.	base_pn	LM5165-Q1	Base Product Number
6.	source	DC	Input Source Type
7.	Ta	30.0	Ambient temperature

Figure 7.3.1.9 - Design Input of the circuit supply #3

### The LM5165 Synchronous Buck Converter

The supply #3 circuit has The LM5165 Synchronous Buck Converter as the main component to perform the step down functionality. The LM5165 chip from Texas Instrument is the synchronous buck converter with high efficiency over wide input voltage and load current ranges. With integrated high-side and low-side power MOSFETs, up to 150-mA of output current can be delivered at fixed output voltages of 3.3 V or 5 V, or an adjustable output.

### Supply #4 DC-To-DC Converter from 12V-to 3.3V with current limited at 1.05A

This circuit design functions as the step down regulated voltage and current circuit that when the input (which the power supplied from the battery) will be stepped down and regulated at 3.3. The output terminal of this circuit will be supplied directly to the MCU that the controls the locking system of the bike rack system and the LCD screen of the MCU.

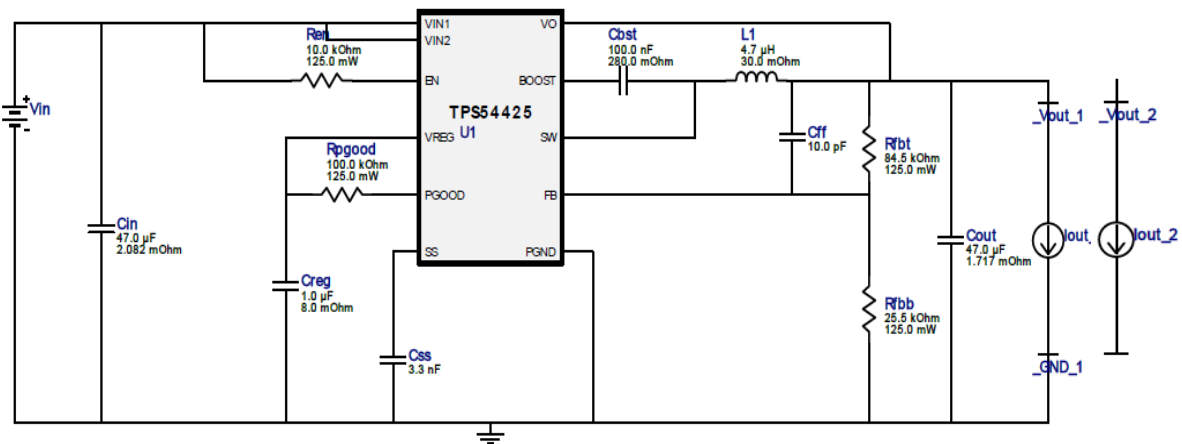

Figure 7.3.1.10 - Schematic Design of the Supply #4 Circuit

### Design Inputs

#	Name	Value	Description
1.	Iout	1.05	Maximum Output Current
2.	VinMax	14.9	Maximum input voltage
3.	VinMin	14.5	Minimum input voltage
4.	Vout	3.3	Output Voltage
5.	base_pn	TPS54425	Base Product Number
6.	source	DC	Input Source Type
7.	Ta	30.0	Ambient temperature

Figure 7.3.1.11 - Design Input of the circuit supply #4

### 1.3.3.2 The TPS54425 Synchronous Step-Down Converter

The supply #4 circuit has The TPS54425 Synchronous Buck Converter as the main component to perform the step down functionality. The main control loop for the TPS54425 uses the D-CAP2 mode control which provides a very fast transient response with no external compensation components. The TPS54425 also has a proprietary circuit that enables the device to adopt to both low equivalent series resistance (ESR) output capacitors, such as POSCAP or SP-CAP, and ultra-low ESR ceramic capacitors. The device operates from 4.5-V to 18-V VIN input. The output voltage can be programmed between 0.76 V and 5.5 V.

### *Supply #5 DC-To-DC Converter from 12V-to 5.0V with current limited at 1.4A*

This circuit design functions as the step down regulated voltage and current circuit that when the input (which the power supplied from the battery) will be stepped down and regulated at 5.0V. The output terminal of this circuit will be supplied directly to the Magnetic Card Reader and RFID reader.

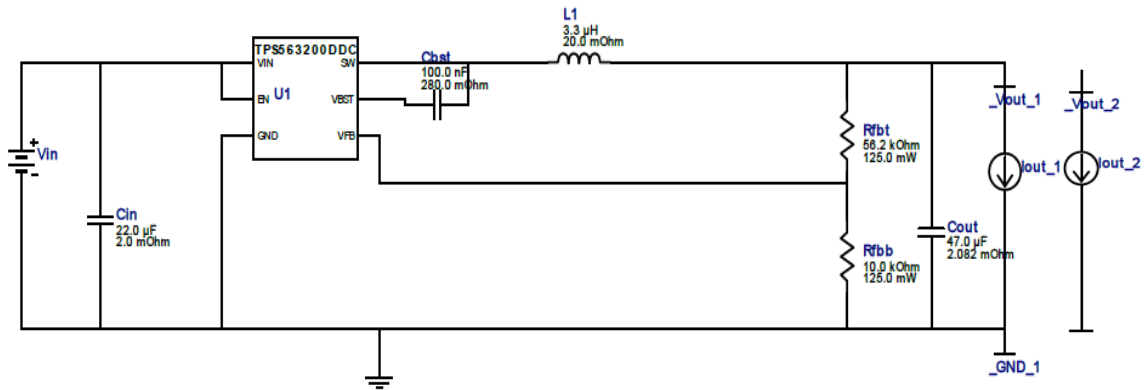

Figure 7.3.1.11 – Schematic design for supply #5

### Design Inputs

#	Name	Value	Description
1.	Iout	1.4	Maximum Output Current
2.	VinMax	14.9	Maximum input voltage
3.	VinMin	14.5	Minimum input voltage
4.	Vout	5.0	Output Voltage
5.	base_pn	TPS563200	Base Product Number
6.	source	DC	Input Source Type
7.	Ta	30.0	Ambient temperature

Figure 7.3.1.12 - Design Input of the circuit supply #4

### *The TPS563200 Step Down Regulator*

The supply #5 circuit has The TPS563200 Synchronous Buck Converter as the main component to perform the step down functionality. The devices are optimized to operate with minimum external component counts and also optimized to achieve low standby current. These switch mode power supply (SMPS) devices employ D-CAP2 mode control providing a fast transient response and supporting both low equivalent series resistance (ESR) output capacitors such as specialty polymer and ultra-low ESR ceramic capacitors with no external compensation components.

### **7.3.2. Solar Panels**

After researching all the possible PV solar panel products, our group decide to go with the 100W Polycrystalline Solar Panel 12V rating voltage which is manufactured by Windy Nation. Our required specification that we want for our system is:

Input Voltage Rating: 12V  
 Input Current Rating: 10Amp

The figure 7.3.2 is the photovoltaic product that we plan to get for our project

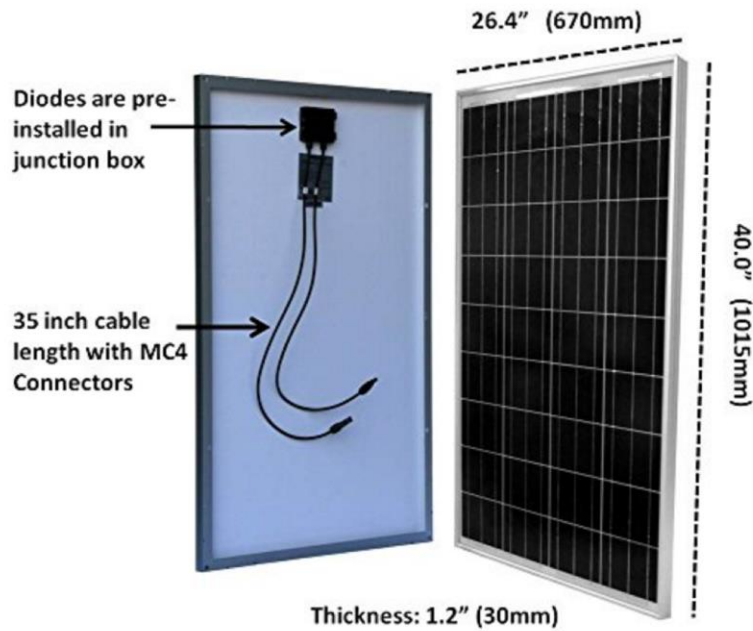

Figure 7.3.2.1 - 100W Polycrystalline Solar Panel from WindyNation (reprint with permission from WindyNation)

The specification data for the solar panel

100W Polycrystalline Solar Panel	
Manufacturer	WindyNation
Quantity	x2
Cost	\$120.00
Maximum Power (Pmax)	100W
Maximum Voltage(Vmax)	17.4V
Open Circuit Voltage (Vo)	21.60V
Maximum Current (Imax)	5.75A
Short Circuit Current (Is)	6.32A
Max system voltage	1000VDC (600VDCVL)
Maximum Fuse Rating	8 A
Nom Operating Temperature	45° C (±2°C)

Table 19 – Solar Panel Specifications

**Decision:** As for this project, our group will go with the parallel configuration to install for the solar panels since it will provide for our system 12V rating voltage and boost our current rating value up to 10 Amp in operation.



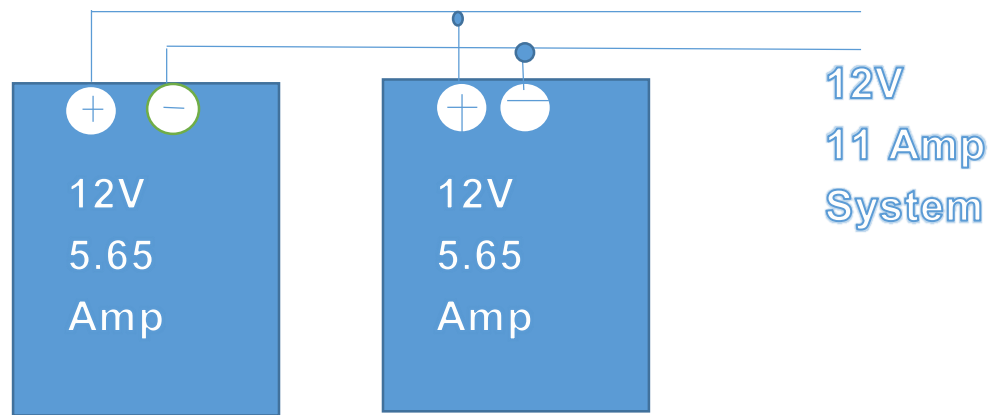

Figure 7.3.2.2 – Solar Panel Connections

### 7.3.3. Power Distribution System

The following section will outline the project details regarding the power distribution which entails the DC-to-DC inverter, .....

#### 7.3.3.1. DC-to-DC inverter

The purpose of design a DC-to-DC converter is to step down the 12V voltage from either charge distribution or battery bank to appropriate voltage that other devices in the system use. There are four voltage regulators used to output 9V, 6V, 5V, and 1.5V. The LM317 is fed from 5V for high efficiency and low heat. The LM317 output is calculated from:  
 $V_o = 1.25 (1 + R1/R2)$ .

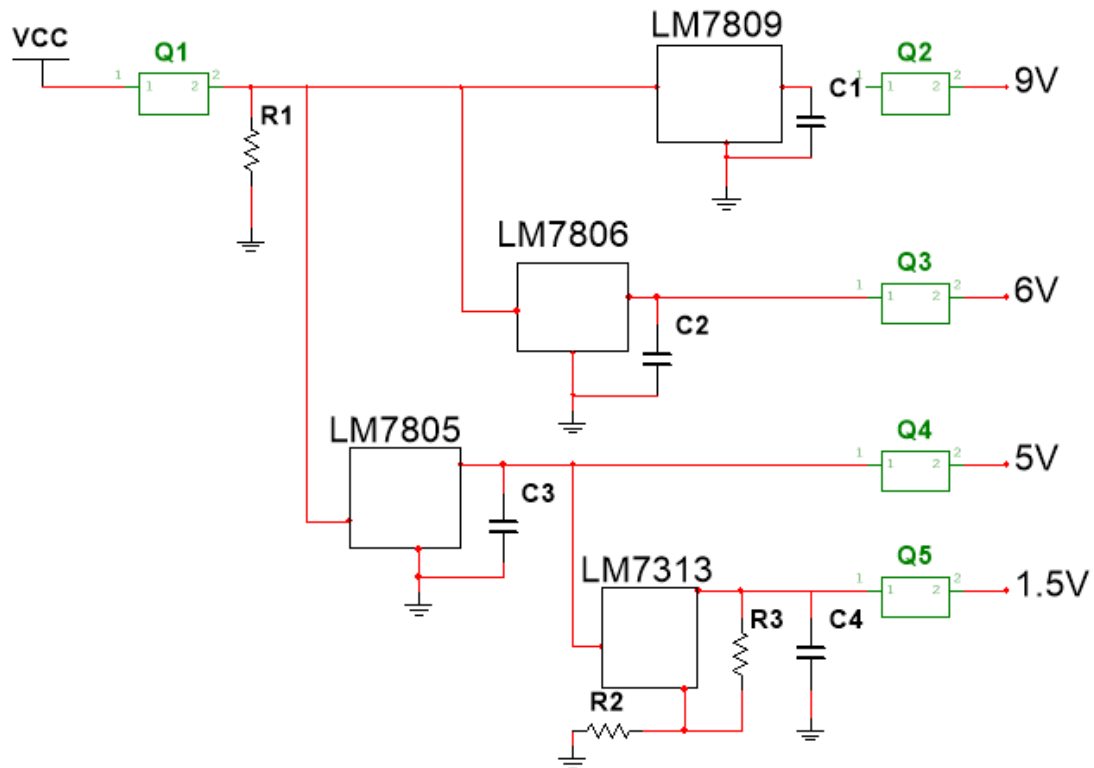

Figure 7.3.3.1 - DC-to-DC Converter with Multiple Outputs

F2.3.4.5 are the output fuses and are set at 500 mA (0.5 A). If the full 500mA is taken from each output then the DC input supply must be capable of sourcing at least 2 Amp. LED 1 is used just to show the circuit is in operation.

### 7.3.3.2. DC-to-AC inverter

*Oscillator*- Constructing an accurate sinusoidal signal in order to duplicate is the first important step to generate a precise pulse width modulation using analog circuitry. To archive this step, an oscillator is needed to produce sine waveform with 60Hz frequency. Even though there are many configurations of oscillators, we want a model which is simple to lower the cost and have low output. A Bubba oscillator satisfies these requirements and be chosen to construct this signal. The circuitry for this oscillator is shown in figure ##. The TL084CN op-amp is used because it meets all requirements and inexpensive. The other components' value are:  $R_F=1.4\text{M}\Omega$ ,  $R_G=350\text{k}\Omega$ ,  $R=26.5\text{k}\Omega$ , and  $C=100\text{nF}$ .

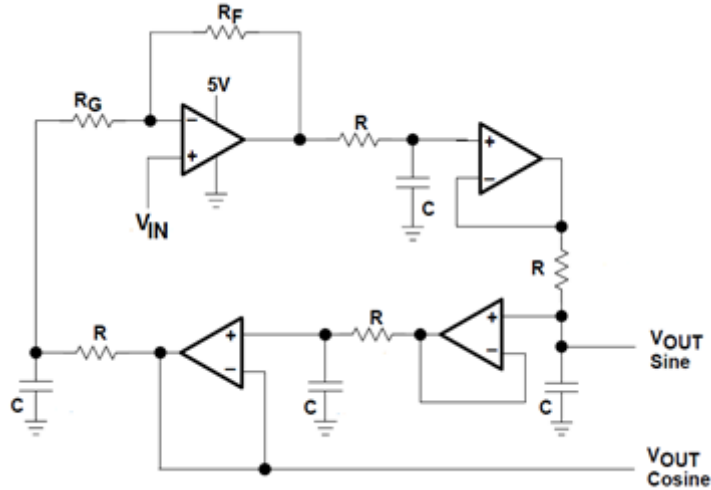

Figure 7.3.2.1 – Bubba Oscillator  
(Texas Instrument – Sine Wave Oscillator SLOA060)

The derived equation for magnitude and phase shift for each RC section is

$$\frac{V_o}{V_i} = \frac{\frac{1}{j\omega C}}{\frac{1}{j\omega C} + R} = \frac{1}{1 + j\omega RC}$$

If we choose value of  $RC = \frac{1}{\omega}$ ,  $\frac{V_o}{V_i} = \frac{1}{1+j}$  which yields to the magnitude of the gain  $|A| = \frac{1}{\sqrt{2}}$  and the phase shift  $\angle A = 45^\circ$ . Four RC sections phase shift 45 degree per section, so this oscillator has 180 degree phase shift in total. However, the inverting amplifier placed across the first operational amplifier return the zero phase shift signal. We noticed that the gain of each RC section is  $\frac{1}{\sqrt{2}}$ , and  $\frac{1}{4}$  for 4 sections. In order to archive the oscillation, the signal passed back to the oscillator must be the same as the one we started out. The solution for this is to construct the gain amplitude for the inverting amplifier equal to 4, so after passing this stage, the signal is alike the original input and continue to oscillate.

All oscillators has a common problem that is nearly impossible to get an exact amplification of the signal. If the amplification is too small then the oscillator signal will decay to nothing, however if it is too large the signal will keep on amplifying until it hits the rails of the op amps. This means that some sort of nonlinear feedback must be implemented with these oscillators so that the signal provided will actually be a stable sine wave.

By the very nature of the op amps, the bubba oscillator solves this problem. When the signal is amplified back into the circuit the signal gets clipped at the peaks of the sine wave. This is because the amplitude is reaching the rails of the op amp allowing the signal to stabilize and providing the nonlinear feedback needed.

*Carrier* -To generate a carrier wave at a switching speed of power supply, we use a triangle-square wave generator. This generator uses an integrator and a Schmitt trigger. The carrier waves can be either saw-tooth or triangular signals; in this case, a triangular wave will be used. As determined in optimal power loss simulations, the carrier wave will be at 50 kHz. The schematic of this generator is shown in the figure ##

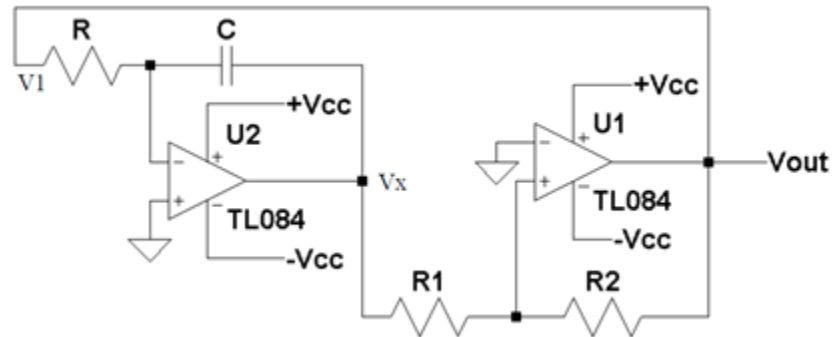

Figure 7.3.2.2 - Triangular-square wave waveform generator  
(EEL 4309 Lab Manual)

The Schmitt trigger have the output  $V_{out}$  feedback to its input  $V_x$  after charging capacitor in a certain period of time. The trigger eventually changes the state.

$$V_{out} = +V_{cc} \text{ when } V_x > -V_{cc}(R1/R2) \text{ , and } V_{out} = -V_{cc} \text{ when } V_x < +V_{cc}(R1/R2)$$

If  $V_{out} = +V_{cc}$  then when  $V_x < -V_{cc}(R1/R2)$ , it switch to  $V_{out} = -V_{cc}$ .

If  $V_{out} = -V_{cc}$  then when  $V_x > +V_{cc}(R1/R2)$ , it switch to  $V_{out} = +V_{cc}$ .

The figure 7.3.2.3 describes how the Schmitt trigger works

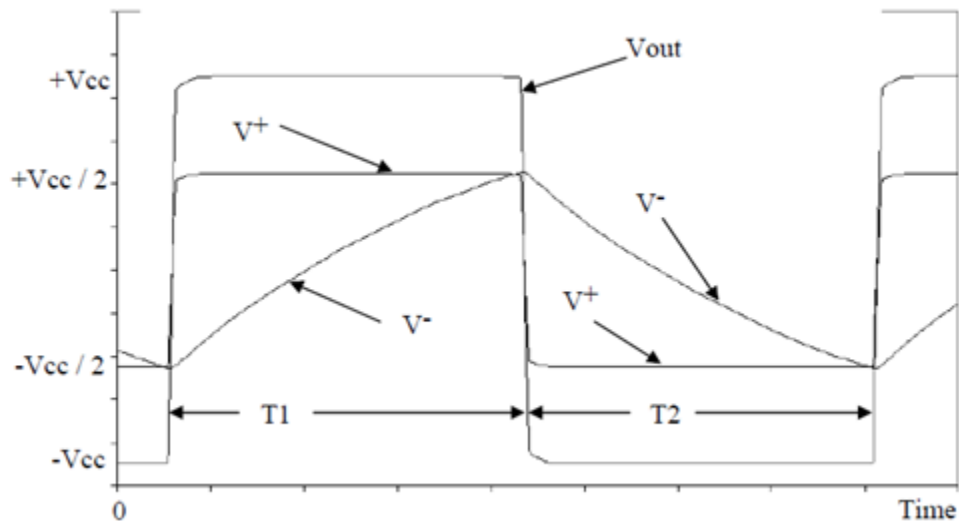

Figure 7.3.2.3 - The Schmitt trigger oscillator waveforms.  
(EEE4809 – Electronic II Lab Manual)

$V_x$  is the integral of  $V_{out}$ , if we set  $R_2 = 2R_1$ , then  $V_{out}$  switch from  $-V_{cc}$  to  $+V_{cc}$  when  $V_x = +V_{cc}/2$  and from  $+V_{cc}$  to  $-V_{cc}$  when  $V_x = -V_{cc}/2$ . The total time  $T_2$  for  $V_{out}$  switching from  $-V_{cc}$  to  $+V_{cc}$  is equal to  $RC$  (seconds) and the total time  $T_1$  for  $V_{out}$  switching from  $+V_{cc}$  to  $-V_{cc}$  is equal to  $RC$  (seconds). In total, we have period of the oscillating signal is equal to  $T = T_1 + T_2 = 2RC$ . The frequency of carrier wave is equal to  $f = \frac{1}{2RC}$ , and the amplitude can be controlled by the value of  $R_1$  and  $R_2$ .

In order to contribute a carrier triangular wave at 5 kHz, the value of components are:  $R =$  Ohms,  $R_1 =$  Ohms,  $R_2 =$  Ohms,  $C =$  uF, and the Op-amp is TL084CN from Texas Instruments.

*Pulse-Width Modulation* - To generate the PWM signal, an error amplifier accepts the carrier signal input and a stable voltage reference to produce an output related to the difference of the two inputs. In this design, the carrier signal is a summation of a triangular wave at 5kHz and a square wave at 60kHz (the square wave is attenuated by a factor of 12). The stable voltage reference of course is a sine wave with a frequency as high as designed output 60Hz. The comparator compares the error amplifier's output voltage with the ramp (sawtooth) from the oscillator, producing a modulated pulsewidth.

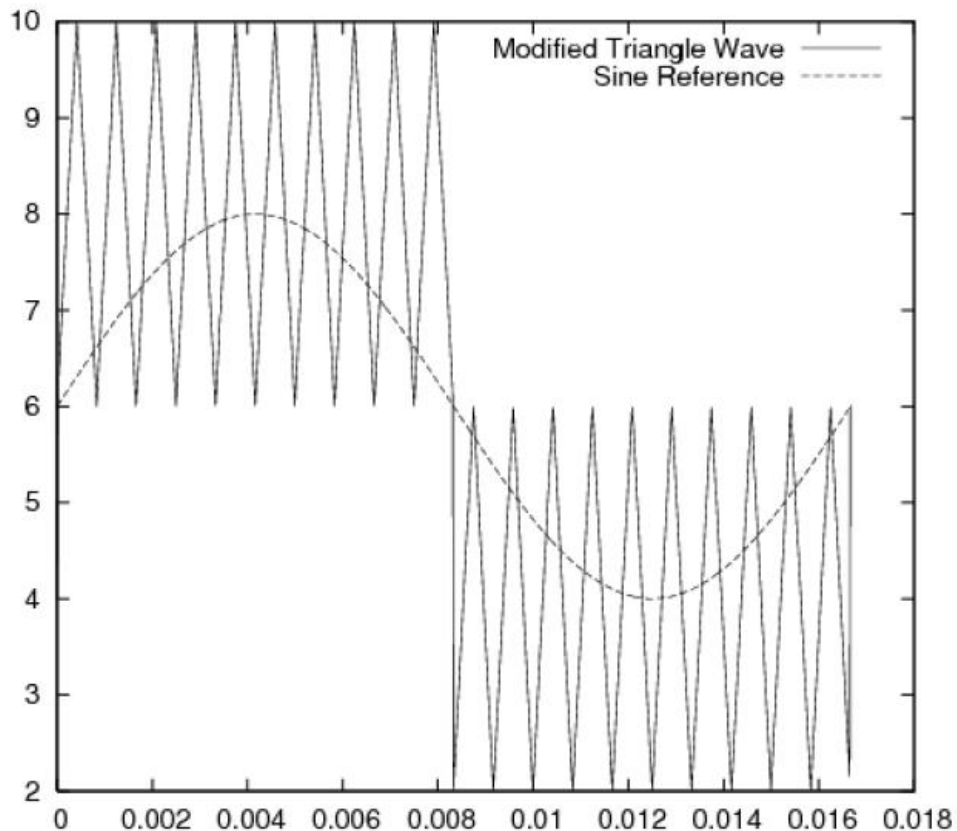

Figure 7.3.2.4 - Modified triangle wave, overlaid with sine reference  
(Permission is pending from www.wpi.edu)

The output of comparator is call Pulse Width Modulated signal, is like in figure below.

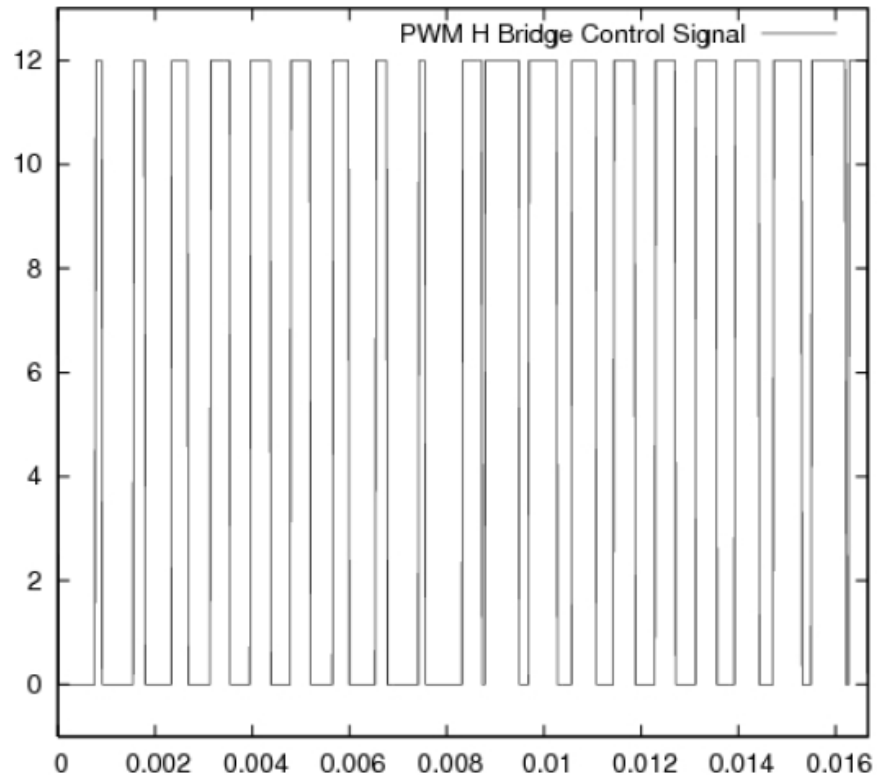

Figure 7.3.2.5 - PWM control signal  
 (Permission is pending from www.wpi.edu)

The comparator output is applied to the switching logic, whose output goes to the output driver for the external power MOSFET. As you can see by close inspection, the duty cycle approaches 1 (or zero) at the peaks and, though it may not be entirely visible, at the zero crossing of the sine wave, the duty cycle first approaches zero, then switches to one (as the square reference changes polarity). Now, because the above signal is for half bridge of an H-Bridge MOSFET configuration, we need to utilize both the above PWM signal and the square wave generated, we can obtain:

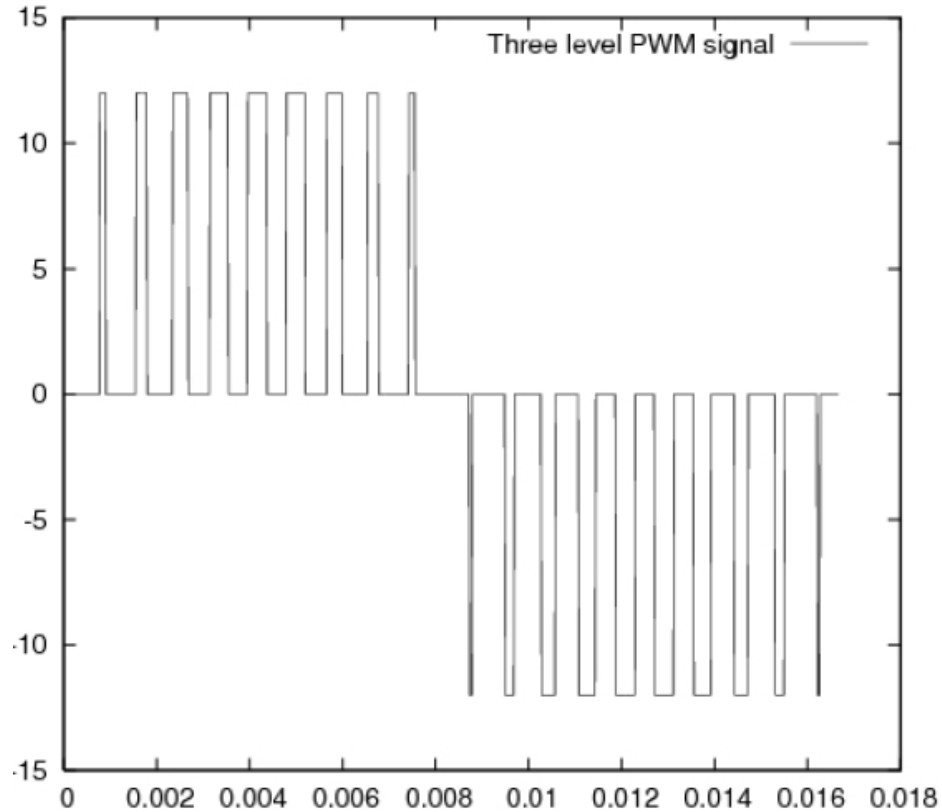

Figure 7.3.2.6 - Trilevel PWM signal  
(Permission is pending from [www.wpi.edu](http://www.wpi.edu))

This is the final signal. If filtered, we will arrive at a sine wave (albeit a 12 V sine wave). If we replaced the 12 V source of these waveforms with a 170 V source, we would have a 170V peak

*H-bridge/Full-bridge MOSFETs configuration* - Generating a sine wave centered at zero requires a both a positive and a negative voltage across the load, for the positive and negative parts of the wave, respectively. This can be achieved by using an H-bridge or full-bridge converter configuration which is composed of four MOSFETs in an arrangement resembles an H. A load is connected in the middle of the bridge like the below figure. By controlling four switches, the voltage apply to the load can be positive, negative, or zero potential.

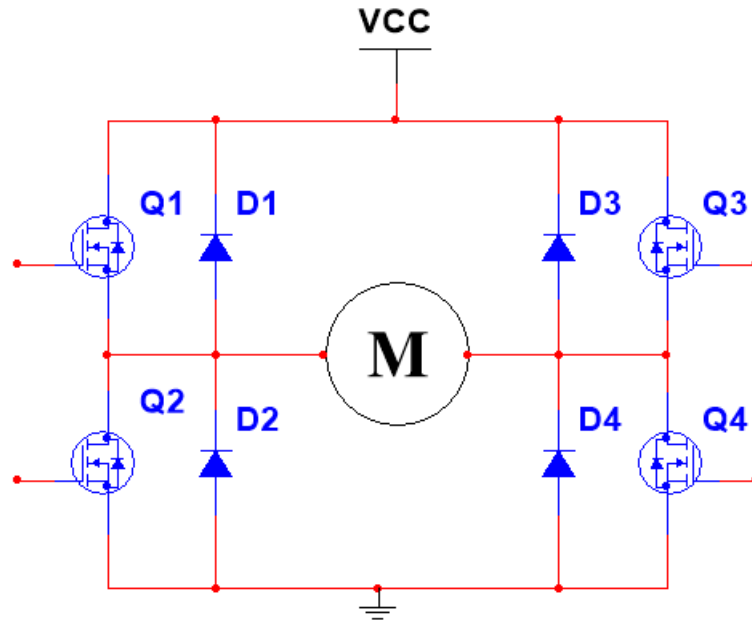

Figure 7.3.2.7 - H-bridge n-channel MOSFET configuration

To minimize the power loss and utilize higher switches speed, N-channel MOSFETs are chosen to use in the design. To obtain the different voltages across the load, there are four possible switches positions that can be used. The most important thing in using H-bridge configuration is never close both switches on the same side at the same time since the high current will flow directly through the devices to the ground and cause damage of the MOSFETs.

High side Left	High side Right	Low side Left	Low side Right	Load Voltage
On	Off	Off	On	Positive
Off	On	On	Off	Negative
On	On	Off	Off	Zero potential
Off	Off	On	On	Zero potential

Table 20 – H-bridge n-channel MOSFET operation

Level translation between PWM signals and voltages required to forward bias high side N-Channel MOSFETS, the *IR2110 High Frequency High-Side and Low-Side MOSFET Driver Integrated Circuit* is chosen. The connection between H-bridge and driver is shown in figure 7.3.2.8.



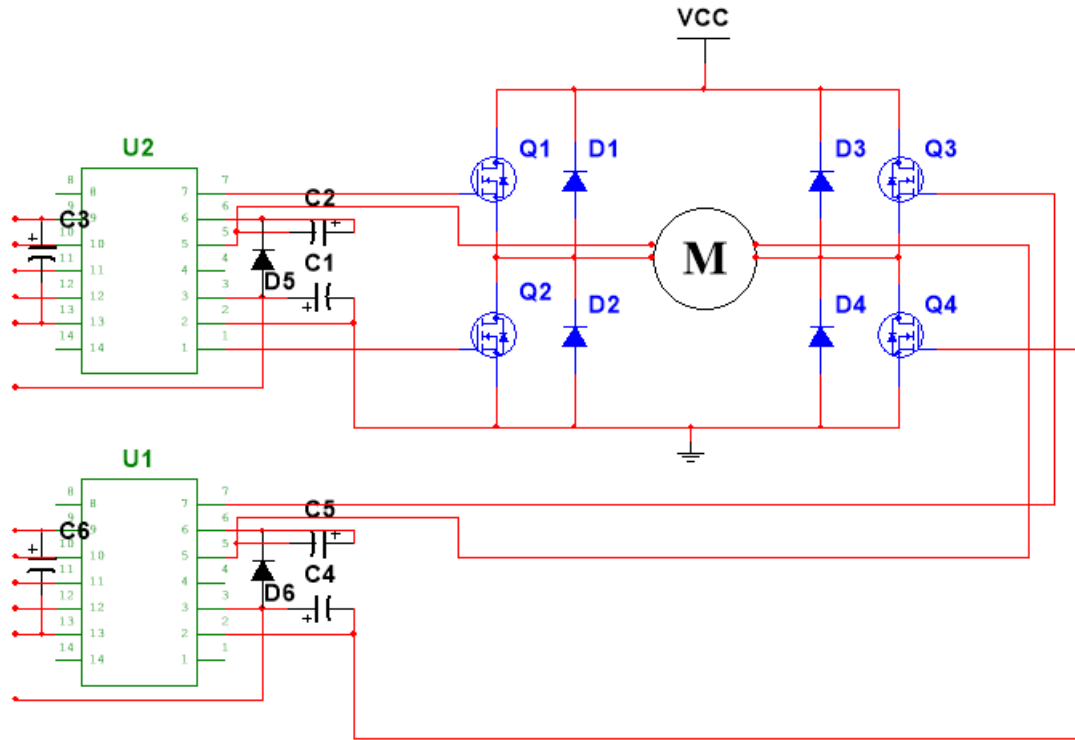

Figure 7.3.2.8 - H-bridge with MOSFET driver

The IR2110 High and Low Side Drive device satisfies all requirements for driving the MOSFETs in the bridge. It is capable of up to 120V at a current rating of 4A at fast switching speeds. This device is required to drive the high side MOSFETS in the circuit designated HO, due to the fact that the gate to source voltage must be higher than the drain to source voltage, which is the highest voltage in the system. This device utilizes a bootstrapping capacitor to maintain a voltage difference of approximately 10V above the drain to source voltage. With a full bridge configuration, two of these devices are utilized, as shown in the above figure. A typical connection of a single IR2110 device is shown.

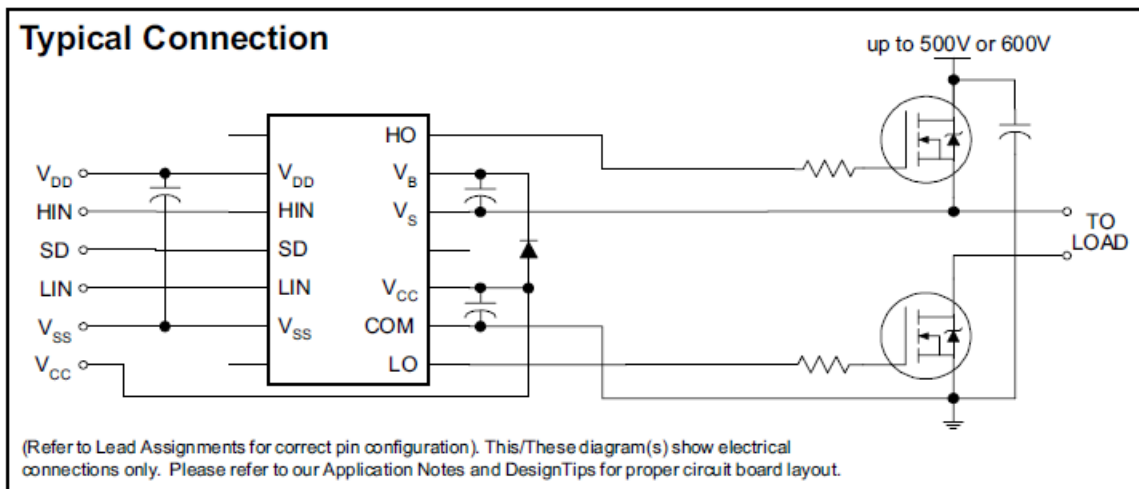

Figure 7.3.2.9 - Typical Application: IR2110 Datasheet  
(Courtesy of International Rectifier)

The IR2110 operation is controlled by PWM signal. The HI and LI input pins of the driver are fed by PWM signal simultaneously. If a HI is detected, the HO output will be driven, otherwise the LO will be driven if a LI is detected. The high-side bootstrap supply pin VB requires an external bootstrap capacitor. VB pin is connected to positive side of that capacitor. The high-side source connection pin VS is connected to the source of high-side power MOSFETs and to the negative side of bootstrap capacitor with typical value range from 0.022uF -0.1uF. Additional pins that require external connections are the VSS pin which will be tied to ground, the VDD pin which will be tied to 12V to run the driver. The VDD is decoupled with VSS(ground) by a decoupling capacitor with typical value from 0.22uF-4.7uF.

Driving four MOSFETs in an H-bridge configuration allows +100, -100, or 0 volts across the load at any time. To utilize PWM signals and this technology, the left and right sides of the bridge will be driven by different signals. The MOSFET driver on the left side of the bridge will receive a square wave at 60Hz, and the right side will receive the 50KHz PWM signal. The 60Hz square wave will control the polarity of the output sine wave, while the PWM signal will control the amplitude. The MOSFETs to be used in the design are the IRFB20N50KPbF Hexfet Power MOSFET, rated for 500V at 20A with a Rds of .21ohm.

*Filter-* An Passive Filter is design for high power inverter. Because the side effect of passive filter is high resistance (due to the long inductance wire) at low frequency, we try to keep the filter cutoff frequency as high as possible. The problem with this choice, however, is that the switching MOSFETs introduce more switching losses at higher frequencies. This would imply that we should switch slower to improve our switching efficiency, which contradicts the filter's need for a higher frequency.

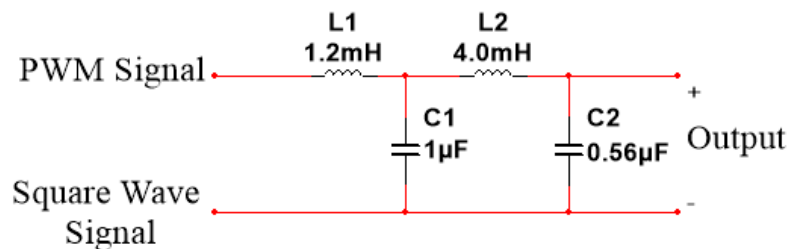

Figure 7.3.2.10 - Two pole LPF

In order to reduce to size of the inductor coil, a two pole low pass filter would be used in order to get a better output rather than a single pole low pass filter. Using this approach there would be twice as many components in the filter but the size of these components would be considerably smaller, lighter and cost less. The simulated frequency response of the filter is supposed to look like in Figure 7.3.2.11.

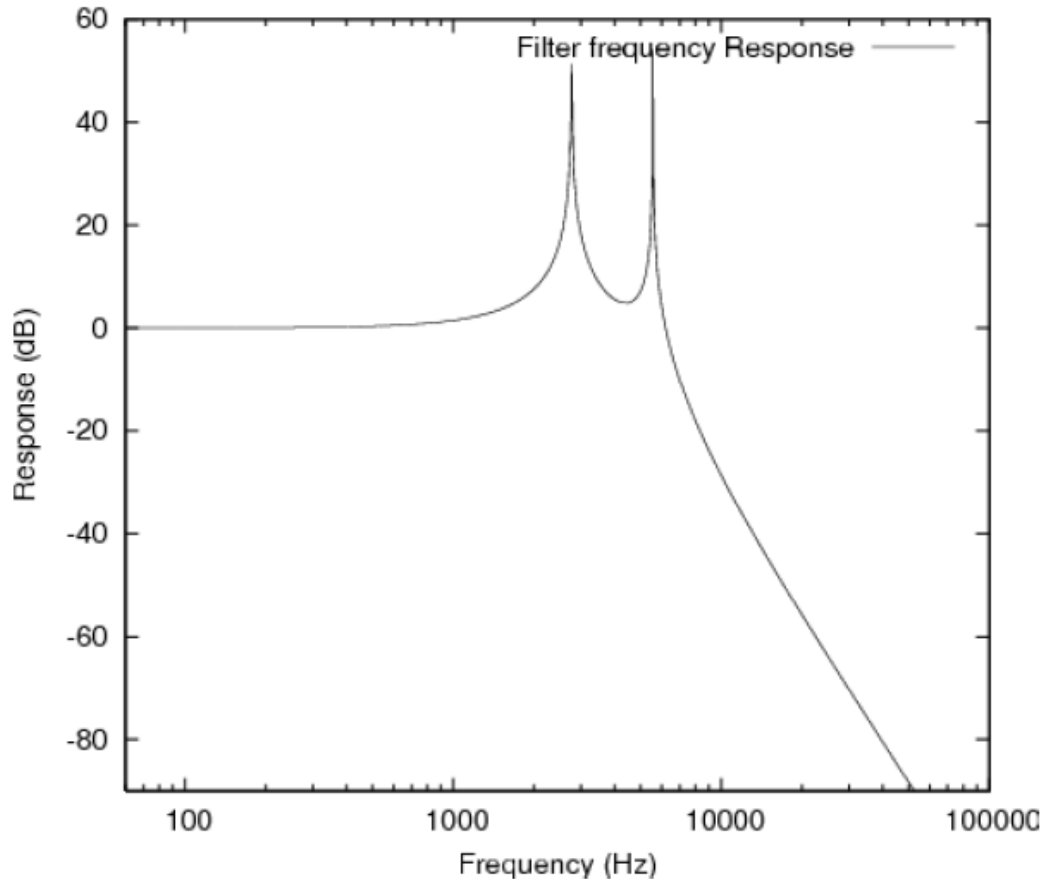

Figure 7.3.2.11 - Filter Frequency Response  
(Permission is pending from [www.wpi.edu](http://www.wpi.edu))

*DC-to-AC Converter Block Diagram* – After all function block are analyze separately as above. An DC-to-AC Converter Block Diagram is constructed in figure 7.3.2.12 to show the relationship between the block. The control unit has three main blocks: 6V reference, sine wave generator and triangular wave generator (both sinusoidal waves are generated by a Bubba Oscillator). The generated waves are implemented by comparator and other small circuitry, then the three level PWM signal is generated and ready feed to the MOSFETs driver. The MOSFETs drivers then able to create three level of control apply on the nChannel MOSFETs in an H-bridge configuration. Finally, before the output is used, it is filtered by an LC Lowpass filter to ensure the output is an sine waveform at 60Hz. In the implementation step, if we have issue of high heat on inductors, the Vcc applying on the H-bridge will be equal to voltage of battery bank. Then at the end, a boost up transformer is needed to raise the output to 110V.

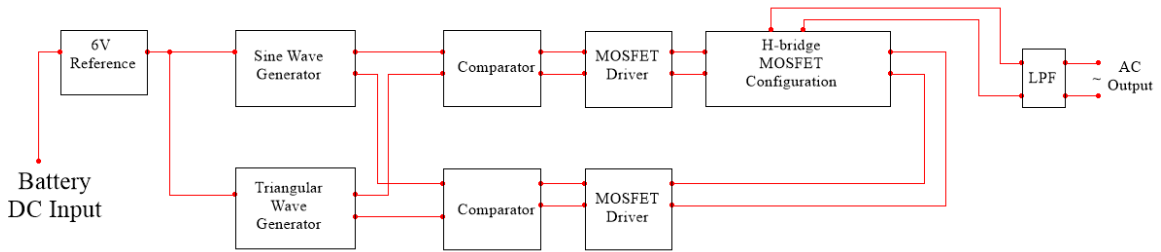

Figure 7.3.3.13 – DC-to-AC Converter Block Diagram

### 7.3.3.3. Circuit Protection

One of important factor in designing circuitry and electric systems is to come up with a protection plan for systems from surges. In this converter design, the protection plan include the ability to drain out all the current when the failure occur. Since a disadvantage of inductor is that it may still conduct the current and damage the other devices. Specifically, if not damped the surge can cause a trouble to all the MOSFET switches which are used to deliver sine wave.

To prevent to current flowing back to off MOSFET switch, the Snubber circuit is used. In this circuit, a resistor and a capacitor is connected parallel with the switch and drain out all the backward current when surge occurs to protect the MOSFETs from damage. The circuit could be improved by connecting a Zener diode so that any large current surge the resistor-capacitor snubber cannot handle gets passed through to ground by the zener diode. The protection plan for the device is shown in the figure 7.3.3.3 below:

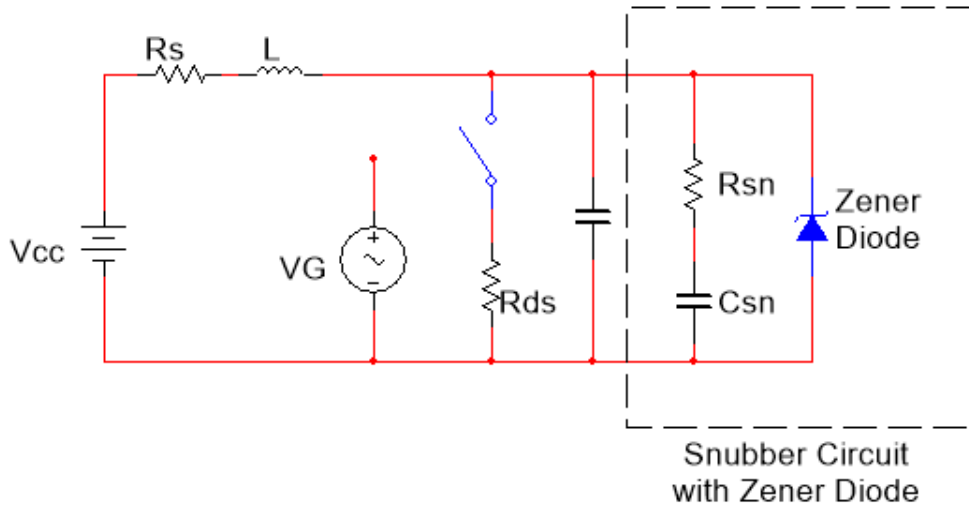

Figure 7.3.3.3 – Inductive Load Circuit with Snubber and Zener Diode

### 7.3.4. Security System

#### 7.3.4.1. Security Camera

The Raspberry Pi Camera Module is being implemented as the security camera for ease of use with the Raspberry Pi 2 Model B microcontroller. It is also capable of capturing images that have high enough quality to be discernable but so high that it takes up

inordinate amounts of memory space. It is a 5 megapixel camera that supports videos at 1080p30, 720p60, 640x480p60/90. For our purposes, 640x480p60 will be sufficient. The camera comes with an attached ribbon cable with connects to the Raspberry Pi at the camera serial interface. The video is recorded as a raw h.264 stream.

The camera will need to be set up. From the product's website, directions show to use a library that has already been made called 'python-picamera'. The library is in the Raspbian archives, and may be easily installed

#### **7.3.4.2.Memory Storage**

An external hard drive will be used to store the video output from the security camera. The data on the hard drive will be deleted periodically to make room for new footage

Many considerations need to be taken to ensure that we have efficient storage space for the footage. The most important factor to keep in mind is that since the footage is being used for security purposes, we want there to be ample time for someone to report a theft and have the footage reviewed.

First of all, we estimate that the camera will be in use for 12 hours of the day. As stated previously, it the footage will be filmed in 640x480p60. One hour of data at this frame size and rate takes up approximately 24.17 GB. Using a 1 TeraByte hard drive, this equates to approximately 40 hours of video footage, or over 3 days worth, before the hard drive becomes full. This should be ample time for someone to report a theft and have the footage reviewed. In such a case, the external hard drive would need to be removed from the bike rack and then hooked up the bike rack authority's computer to view the footage.

#### **7.3.4.3. Lighting System**

The lights will be turned on when motion is sensed and if it is between 6:00 PM and 6:00 AM on any given day. Ultimately, a motion sensor paired with a RTC was chosen as the best option for recognizing when the lights will need to be turned on. This results in less power consumption than the light sensing technologies. We will only have the lights on when people are present to reduce power consumption and since it unnecessary for the lights to be on when nobody around to need them.

#### **7.3.4.4. Microcontroller (FOR LIGHTING AND CAMERA)**

The MCU will remain in low power mode until someone walks by. When a person is sensed, the MCU will wake up, and a subroutine will check if it is the proper time of day to turn the lights on.

We decided to use the Raspberry Pi 2 Model B for its higher clock speed and ease of camera implementation. Since the microcontroller will be used to control both the camera and lighting systems, and it will have several peripherals connected to it. The external harddrive will be used to store the video footage taken by the security camera and will be connected to the microcontroller via a USB port. The motion sensor, real time clock, and the LED strip will connect to it through the GPIO pins. Table 20 below outlines what

pins on the Raspberry Pi have what operations, which will be referred back to later with the schematic of the camera and lighting systems. The Raspberry Pi Camera Module will be connected to it through the camera connector.

An SD card is needed to put the program on the MCU. The creator of the MCU suggests using a size of no less than 8 GB for storage space, which will leave us with ample storage space. The Raspbian operation system was optimized for the Raspberry Pi, and has many online resources for downloading packages to make programming the MCU on overall easier experience. Raspbian will need to be installed onto the SD card before the Raspberry Pi can be used. The Raspberry Pi comes with the ability to be programmed in several different languages, including C, Python, and C++. Python is what the creator's of the Raspberry Pi suggest newcomers to use, and what we have chosen to program this MCU in. Assuming familiarity with the C language, Python should be fairly similar but much cleaner to use. The program will be developed in the IDLE IDE.

The power will come to the MCU from the batteries or back up solar power supply, which will be supplying 12 VDC to it via a micro USB port. However, the Raspberry Pi may only take 5V at 2A, so a voltage divider circuit will need to be implemented so that it is being supplied a safe amount of voltage and current.

A heat sink will need to be attached to the Raspberry Pi, considering this project is meant for outside use, and temperatures in Florida can get into the 90 degree Fahrenheit range during the summer months.

Pin	Function
1	3.3 V DC Power
2	5 V DC Power
3	GPIO02 (SDA1, 12C)
4	5 V DC Power
5	GPIO03
6	Ground
7	GPIO04
8	GPIO14 (TXD0)
9	Ground
10	GPIO15 (RXD0)
11	GPIO017
12	GPIO18
13	GPIO27 (GPIO_GEN2)
14	Ground
15	GPIO22 (GPIO_GEN3)
16	GPIO23 (GPIO_GEN4)
17	3.3 V DC
18	GPIO24 (GPIO_GEN5)
19	GPIO10 (SPI_MOSI)
20	Ground
21	GPIO09
22	GPIO25
23	GPIO11 (SPI_CLK)
24	GPIO08 (SPI_CE0_N)
25	Ground
26	GPIO07 (SPI_CE1_N)
27	ID_SD (12C ID EEPROM)
28	ID_SC (12D ID EEPROM)
29	GPIO05
30	Ground
31	GPIO06
32	GPIO12
33	GPIO13
34	Ground
35	GPIO19
36	GPIO16
37	GPIO26
38	GPIO20
39	Ground
40	GPIO21

Table 20 - Raspberry Pi 2 Model B Pins

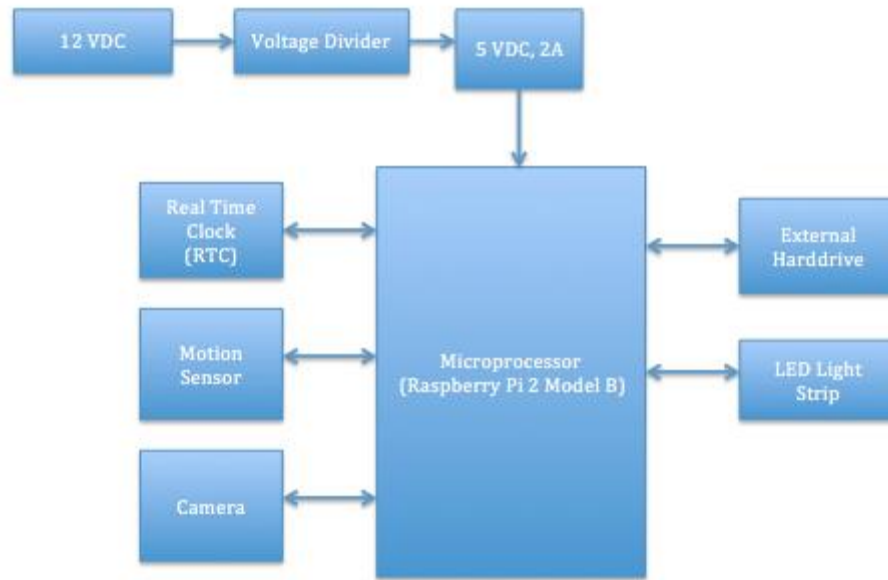

Figure 7.3.3.4 – Block Diagram of Security Camera and Lighting System

#### 7.3.4.5. Motion Sensor (for Camera and Lighting System)

The PIR motion that will be on the bike rack has an adjustable delay before firing of about 2-4 seconds. The sensitivity of its response to motion may also be adjusted. The sensor comes with 1 foot cable so that it may be mounted at a proper position. It runs on 5v-16 power, so may gain its power supply from the 5V pin on the Raspberry Pi. It may sense motion within a 7 meter range and 120 degree cone, which is a sufficient area for this bike rack. As discussed in the research on the motion sensor, as someone walks by they must pass up the two slots on the motion sensor. It must be angled properly to see a person walking by the bike rack to trigger a response on both of the slots.

*Lights-* An LED light strip has been chosen to light the system. This allows us to adjust the length of the light to the size of the bike rack structure. Referring to Table 21, we see that there are 300 LEDs in a reel of these lights. It can be cut every 3 LEDs, so it may be cut in 100 different places, or every 0.05 meters. This gives us high level of control of the length of the strip to adjust to our needs.

In addition, as we can see in Table 21 below, the strip is a lifetime of 50,000 hours. Considering there are 8760 hours in a year, this equates to 5.7 years before the strip needs to be replaced. This makes it very low maintenance.

LEDs were picked for their low power consumption, since we are concerned with how quickly are depleting the batteries and stored solar energy. This particular strip only uses 4.8 watts per meter. Only one meter of the strip will be used, so it will only be consuming 4.8 watts.



An NPN transistor will be implemented so that the relay will be energized to switch on the LED strip. The relay that is used to switch the light circuit open and closed as been picked in accordance to the LEDs voltage requirements.

Knowing the power and the voltage needed for the light switch, we may calculate how much current it needs:

$$P = IV$$

$$4.8 = I(12)$$

$$I = 0.4 A = 400 mA$$

The relay's and its surrounding components calculations will thus be made so that LED strip the current calculated above going to it.

Voltage	12 VDC
Power Consumption	4.8 W/m
Life	50,000 hours
Length	5 m
Number of LEDs	300

Table 21- LED Light Strip

*Real Time Clock* - This is generally when it is dark outside. Since the MCU will not be connected to the Internet, we are using a real time clock (RTC) to be able to keep track of the time. The ChronoDot RTC we picked was chosen because it may be directly snapped on to the MCU'S GPIO pins, making it easy to implement. It will need to have the time initially set up when implemented.

The RTC includes a CR1632 battery, which can have a lifespan of up to 8 years, if the device is used only when the 5V power supply is available. The power may come from the batteries of the bike rack, with a voltage divider between. Additionally, the time on the RTC will only drift by a minute per year, so it will never be off by very much. This is contrasted with other RTCs, which may drift by a few minutes per month. The RTC will need to be connected to the power supply, ground, and GPIO02 and GPIO03 for I2C communication between it and the MCU.

*Relay* - A relay will need to be used to switch the lights on and off. Relays have three current and voltages ratings: coil, AC load, and DC load. We are concerned mainly with the coil rating since that is what is needed to activate the switch. However, it is also necessary to keep the DC load in mind, since it dictates the maximum current that the switch contacts may endure.

The relay will be switched open and closed through setting the GPIO pin that it connects to to either high or low. When it is set to high, the switch will be closed and the lights turned on. When it is low, the switch will be open and the lights turned off.

The GPIO pins output 3.3 V when set to high. The maximum output current for the GPIO pins is 16 mA per pin, with a maximum of 50 mA for all pins combined. So, we can expect a maximum of 16 mA to be coming from the GPIO pin to the relay.

The relay that we will be using is single pole, double throw (SPDT), and has a minimum permissible load of 44 mA and 12 VDC to switch, as may be seen in Table 22 below. However, it may take up to a maximum of 10 A.

Coil Current	44 mA
Coil Voltage	12 VDC
Maximum Current	10 A

Table 22 - Relay

Although not the fastest way of switching a circuit, it still has a time of switching on in the off in the matter of milliseconds. In the graph below, it is shown how quickly this will happen, going even faster the more voltage that is applied.

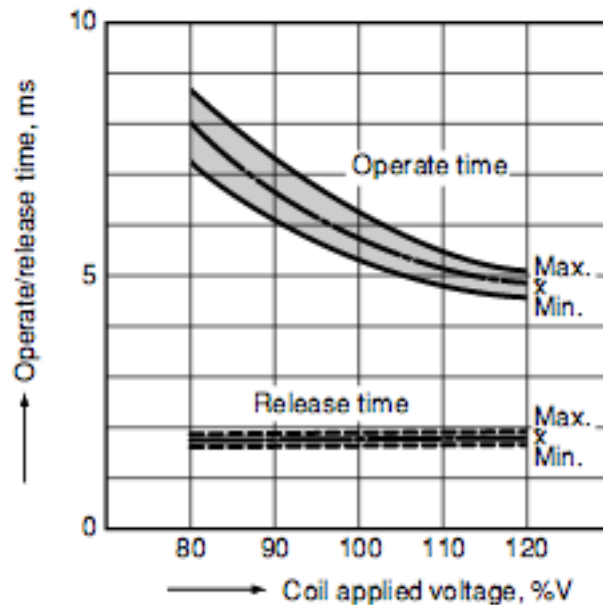

Figure 7.3.4.5.1 - Courtesy of Jameco Electronics

So displays that response time of the relay will not be an issue, and the lights will be able to turn on and off without the user noticing any sort of delay.

*Diode* - A diode will need to be implemented in parallel with the relay, between it and the Raspberry Pi. It will be used as protection due to the voltage spike that occurs when the relay switches off. The diode will put a current briefly through the relay so that the relay's magnetic field does not dissipate instantly, but it does so in a more gradual manner, adding on a few milliseconds to its deactivation time. This will limit the voltage induced by the relay, ensuring that we do not damage the rest of the components in this manner. The current rating of the diode should be at least that if not greater than the relay coil's rating. As mentioned earlier, the coil rating of the relay is 12 VDC. The diode was picked to be able to handle the coil's ratings. A 1N4001 diode will be used, which has a forward current rating of 1 amp, which is much greater than the relay's minimum 44 mA.

*Transistor* - A transistor needs to be connected between the Raspberry Pi, where the high pulse will be sent out, and then sent to the relay. The purpose of the transistor is to take the signal from the MCU into the base, and emit a signal from its collector so that the relay's coil becomes energized when the transistor is saturated. The transistor must be able to handle the current that is needed by the relay. To make matters easy, we will make the current going to the relay the current that is required by the LED strip. This way, both will be powered efficiently in one motion. A few calculations must be made to ensure the transistor is doing its function.

The maximum collector current,  $I_C$ , of the PN2222A NPN transistor is 1A, which is significantly greater than the 400mA that the LED strip needs, and is well within the range that the relay can handle. Also note, the max collector-emitter voltage,  $V_{CE}$ , is 40 V. Our goal of 12 V for  $V_{CE}$  is thus obtainable. With the maximum current gain the minimum base current,  $I_B$ , needed for saturation may be calculated:

$$\beta = \frac{I_C}{I_B} = 300 = \frac{400mA}{I_B}$$

So As discussed earlier, the Raspberry Pi can output a maximum of 16 mA from a single GPIO pin. This current will be a safe amount.

As shown in figure 7.3.3.5 below, looking at the 25 degree Celsius line, the base-emitter voltage for saturation,  $V_{BE}$ , climbs up to approximately 1V as  $I_C$  reaches 500 mA. We will be safe and use a  $V_{BE}$  of 1V. With the GPIO pin output in 3.3V, we calculate the voltage drop across the base resistor as  $3.3V - 1 = 2.3V$ . The base resistor value may then be calculated as  $2.3/1.33mA = 1.73 \text{ k}\Omega$ .

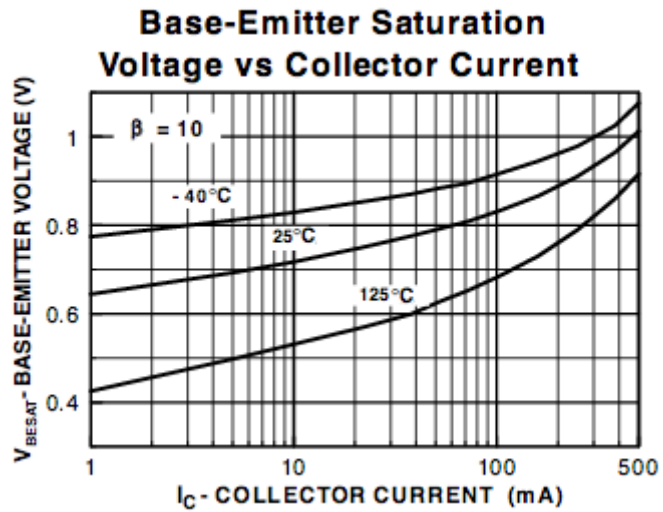

Figure 7.3.4.5.2 - Courtesy of Adafruit

### 7.3.5. Locking Mechanism

In order to build a locking system with high level of secure and low power consumption, we use a pull-type solenoid with long stroke and high pull force. The solenoid will install to a frame box with its stroke hanging on one side of a V-rod. The other side of the rod, there is a spring to pull the rod all the time and keep the bike secure. The figure 7.3.5.1 shown below describe the top view of the locking mechanism.

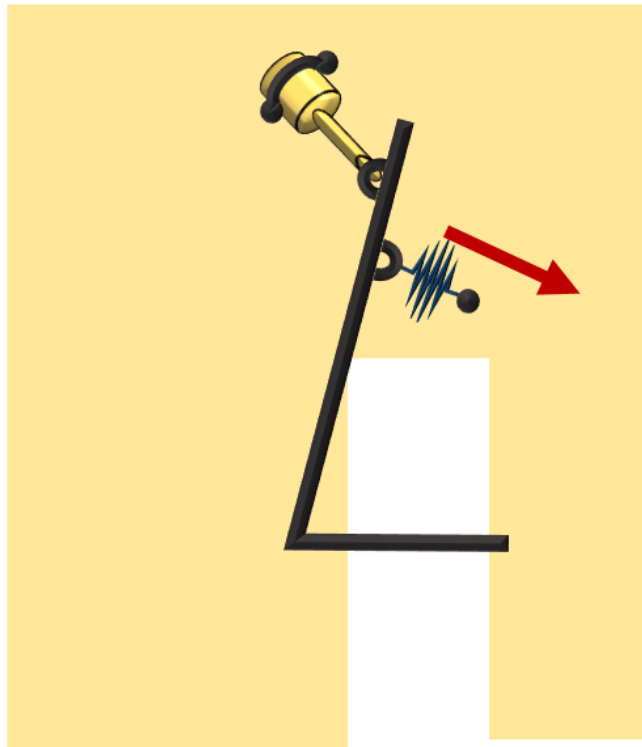

Figure 7.3.5.1 – Secure Lock using Solenoid, spring and V-rod

The solenoid stay at rest condition all the time until it receive signal from MCU to open the lock. The current then go from battery bank to the solenoid to turn it on, the solenoid now operate by pulling its stroke. The lock keeps being open for few second, bike insert or take their bike out, then the solenoid is off again. The spring now pull the V-rod back to it closing position. The figure 7.3.5.2 describes the operation of solenoid, spring and V-rod in the locking mechanism.

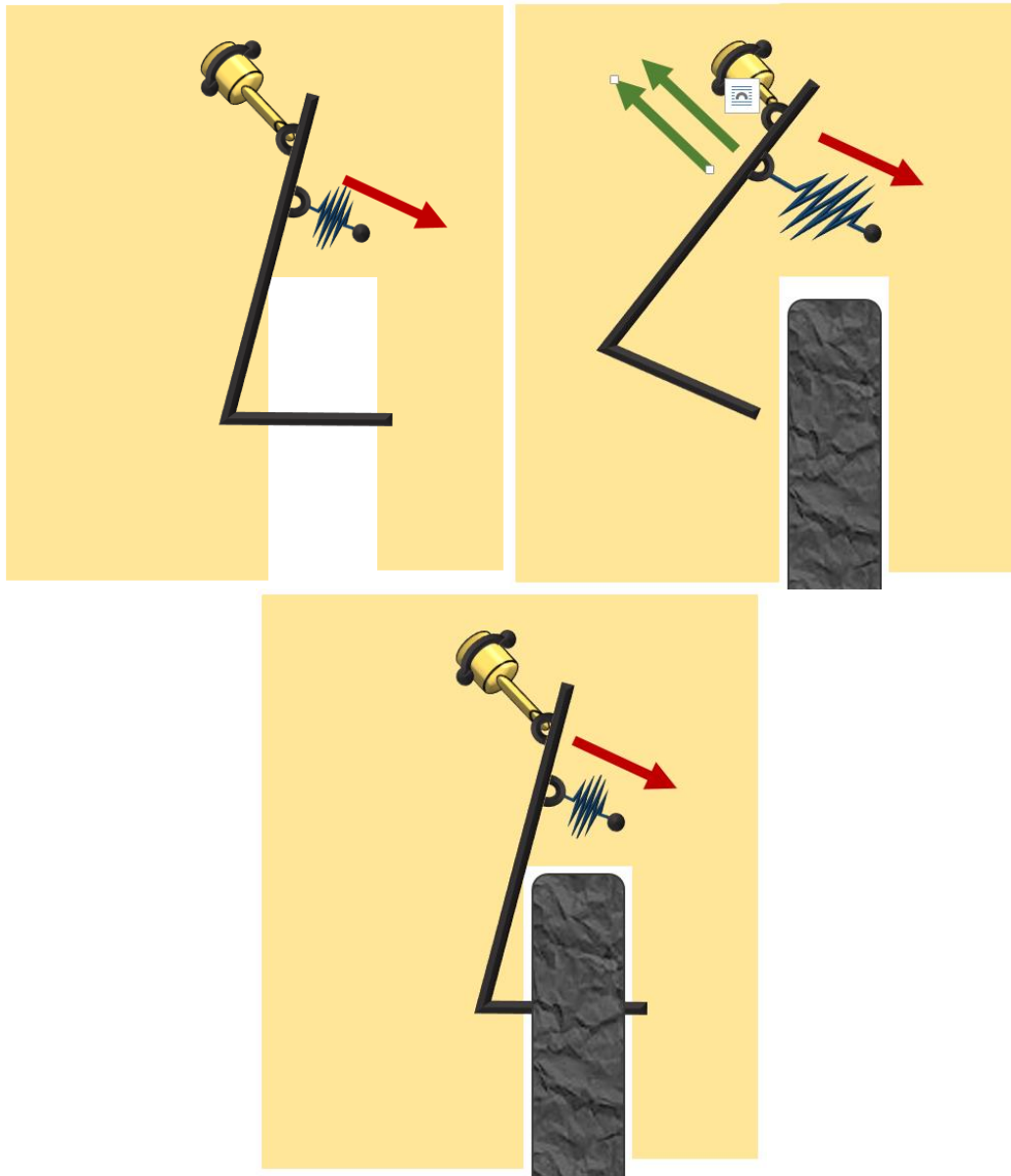

Figure 7.3.5.2 – The locking mechanism operation

The V-rod is made from a medal rod with the dimension is 4 inches on the short side and 7 inches on the long side. The spring hang between the frame and one side of the rod with the maximum pull force less than the solenoid minimum pull force to ensure the solenoid is able to pull out the rod.

### **7.3.6. Central Microcontroller System**

In order to fulfill our wireless requirement, we decided to choose the TI CC3200 SimpleLink Wi-Fi MCU. With its relatively low-cost, the SimpleLink MCU gave us our best option, although it was not as memory worthy, lacking half the memory capability that the Tiva C Series offered. The SimpleLink is a Harvard architecture 32-bit ARM Cortex MCU. ARM processors make up a huge percentage of the current MCU's used in today's products. Using an ARM, it provides us with practice that many companies will look for when scanning through our credentials in an interview.

Some of its power consumption features offer various Low Power Modes with significant clock speed (upwards of up to 80MHz) and utilizes IEEE754-compliant single precision Floating-Point Unit (FPU). Additionally, the WiFi package already includes 802.111 standard, encrypted network certificates and TCP/IP stack configuration. It has multiple SPI (Serial Peripheral Interface) which will be useful in driving a display screen. The endless solutions that this microprocessor entails provides everything we need. Memory requirements are only 256KB however, if extra space is needed for additional data, we can use an SD card. Another factor for why this MCU was chosen: it was free. We were able to request samples from TI, landing us 5 TI CC3200 in case of an unfortunate event.

### **7.3.7. Magnetic Card Reader**

Since we only need a simple task done by this component, there was no point in redesigning our own magnetic card reader. Therefore, we went ahead to purchasing our own. Coming in under \$30, the OSAYDE MSR90 Magnetic card reader offered 3 track dual-reading (HiCo and LoCo), and is plug and play. It is a password protected system and can read every type of card: ISO, ANSI, CDL, and AAMVA.

### **7.3.8. RFID Reader and Tags**

RFID reader we chose was a 125kHz USB Contactless Proximity Sensor Smart ID Card Reader made by RoyFee Electronics. They too provide a plug and play device, interfaced via USB. The tags are also 125kHz compatible, made by Seedstudio. There are three passive keychain tags and two passive RFID cards. Each one has their own unique identification number.

*FTDI Chip* – In order to interface the RFID reader and the magnetic card reader and properly transmit data to the mcu, it was found that an FTDI board was necessary to purchase in order to interface USB data to MCU's. FTDI stands for Future Technology Device International, which is a Scottish company, not a nomenclature, whose specialization is USB technology. [4]

## **7.4. Software Design Details**

The following section will overview the software design of the project. It will include the choices made for design of the user interface, the display screen chosen, and the security system.

### 7.4.1. User Interface

The concept of the bike sharing UI is relatively simple. Any use who wishes to use a bike will have to come to the screen first. Since this is an energy conscious project, the system will always be in Low Power Mode (LPM) and will need to be woken by an external factor, this being the user pushing a button /screen to wake it or motion sensor activated. Once the system boots (using the TI Simple Link, it is a matter of microseconds), the user will be prompted to swipe their UCF ID card in order to authenticate their use of the system. If the user swipes any other card besides their UCF ID card, they will be prompted to swipe again. The second prompt will give the user a choice of which option they would like to choose (i.e. rent a bike or charge a bike).

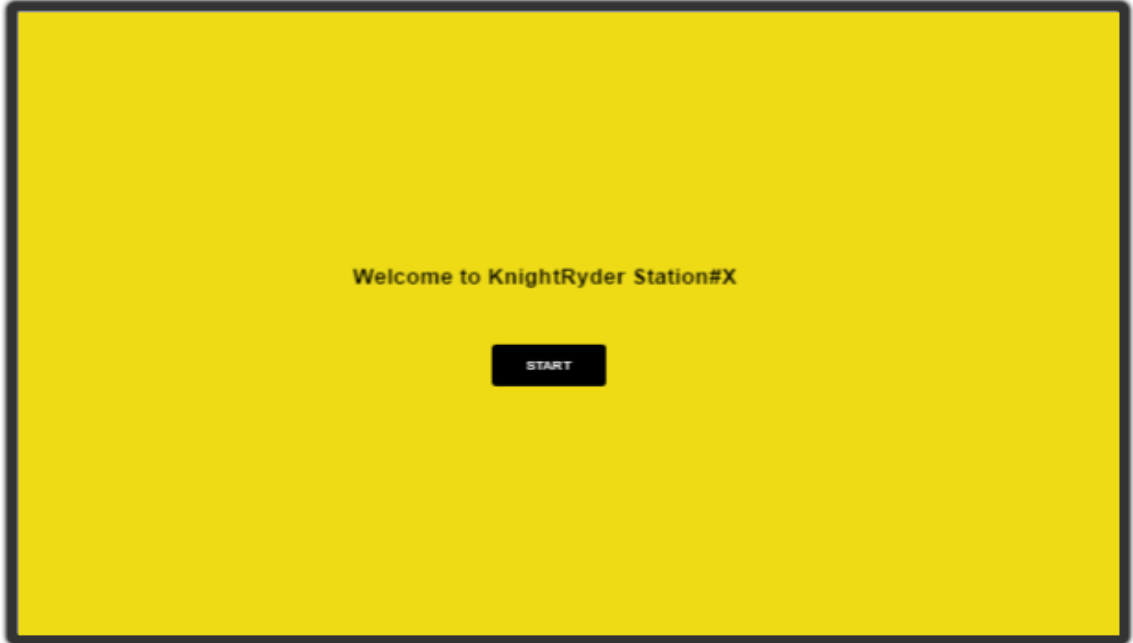

Figure 7.4.1.1 - UI Start Menu

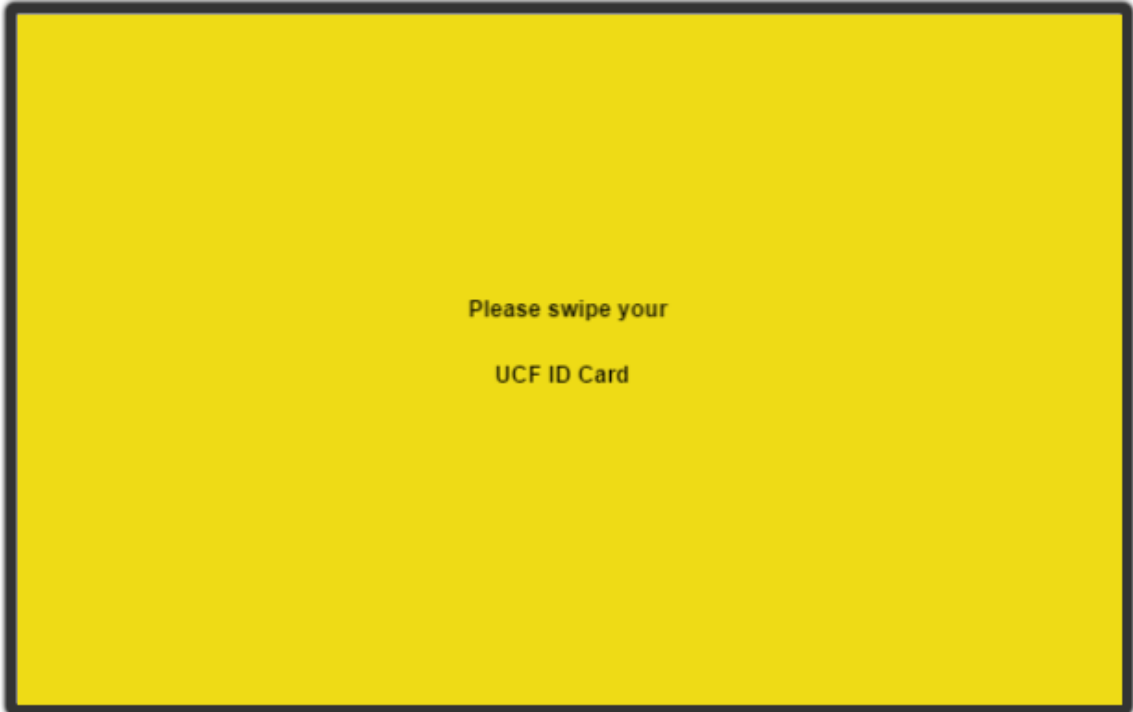

Figure 7.4.1.2 - Swipe Prompt

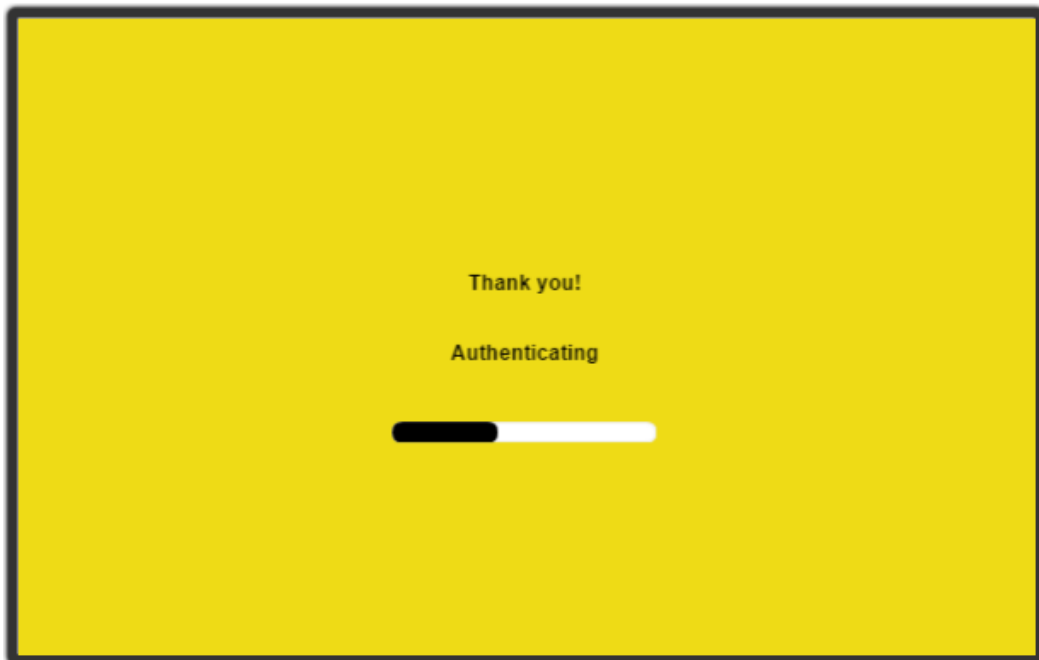

Figure 7.4.1.3 - Authentication

Once the user is authenticated, the next available bike space number in the queue will be displayed on the screen. The system will allocate a few seconds for the user to retrieve the bike. At this point, the system has already connected the user with the identification of that bike associated with the identification tag. Only one bike is allotted per user per rental time.



Therefore, a user cannot rent multiple bikes at the same time, preventing misuse of the system.



Figure 7.4.1.4 - Enter bike number screen

Once a user returns with the rented bike, all they need to do is to place the bike in any available spot. A green light will display that the RFID tag was received by the system and the system executed the rental time for said user. The software block diagram is shown below in Figure 7.4.1.5 for the complete process.

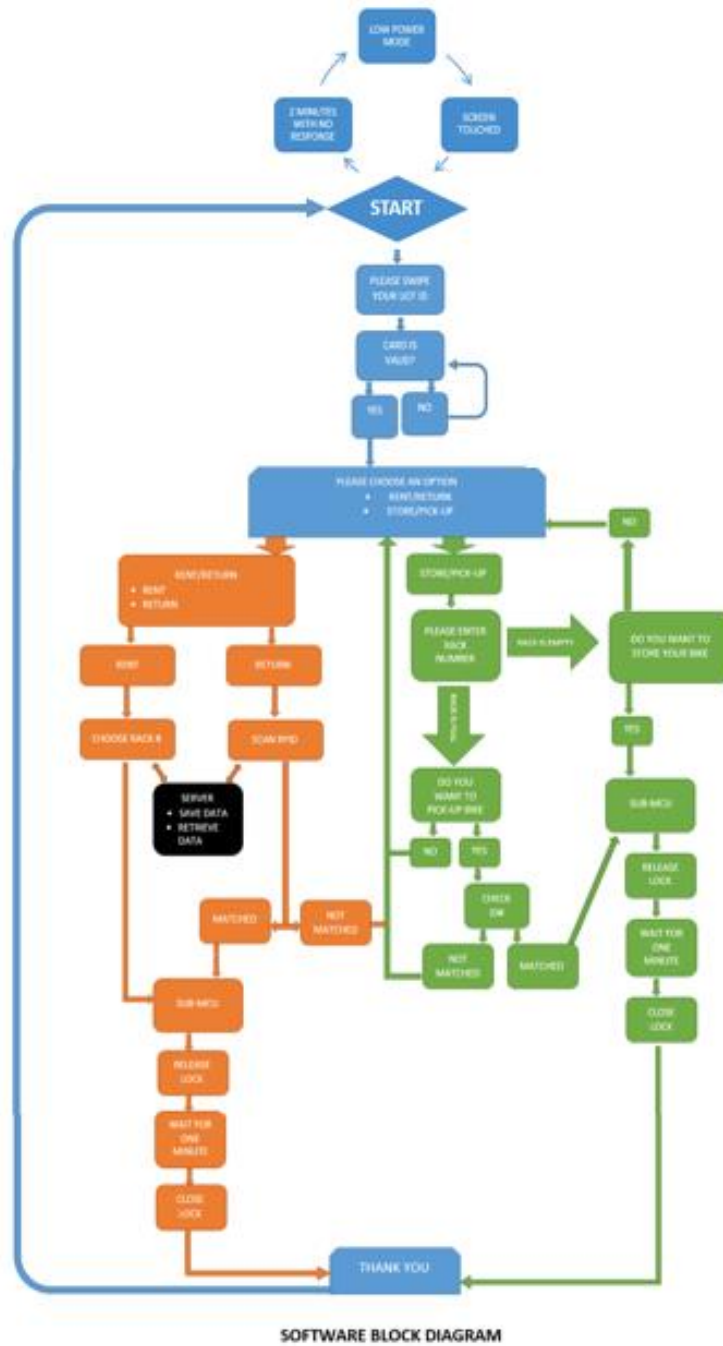

Figure 7.4.1.5 - Software Diagram

*Embedded design details*

There are three main components that the MCU will be interfaced with, the LCD screen, the magnetic card reader and the RFID reader. Since the MCU already has a wireless module integrated into the chip, the need to interface directly with one is removed. We will go in detail about how input/output of data to the MCU is transmitted and received from the server, the initializing states of power on and waking states, low power modes. For this

project, we will be using Code Composer Studio for the main microcontroller unit which is the TI CC3200 SimpleLink.

*RFID to MCU*

The RFID reader will constantly be on to be able to read a tag if someone drops off a bike. Therefore, the main MCU will have to be available to receive the data from the tag and then transmit it to the server. Since requiring the MCU to constantly pulse the RFID reader would be power hogging, we will configure the MCU to be woken up by an interrupt from the RFID reader instead and the RFID reader will have to constantly be on. Also, alongside data being received, the system will also have to lock the bike when the user drops it off immediately. There needs to be two signals the MCU sends, one to the server and the second to the locking MCU or mechanism. For the case that a user is renting a bike in place, the system will already know what bike id is stored at specific bike number because each RFID reader has a specific identity as well. Therefore, user information will have to be matched to the tag id of the bicycle in order for proper time stamping and inventory. The data flow diagram in Figure 7.4.1.6 below describes the behavior of these two systems interfaced together.

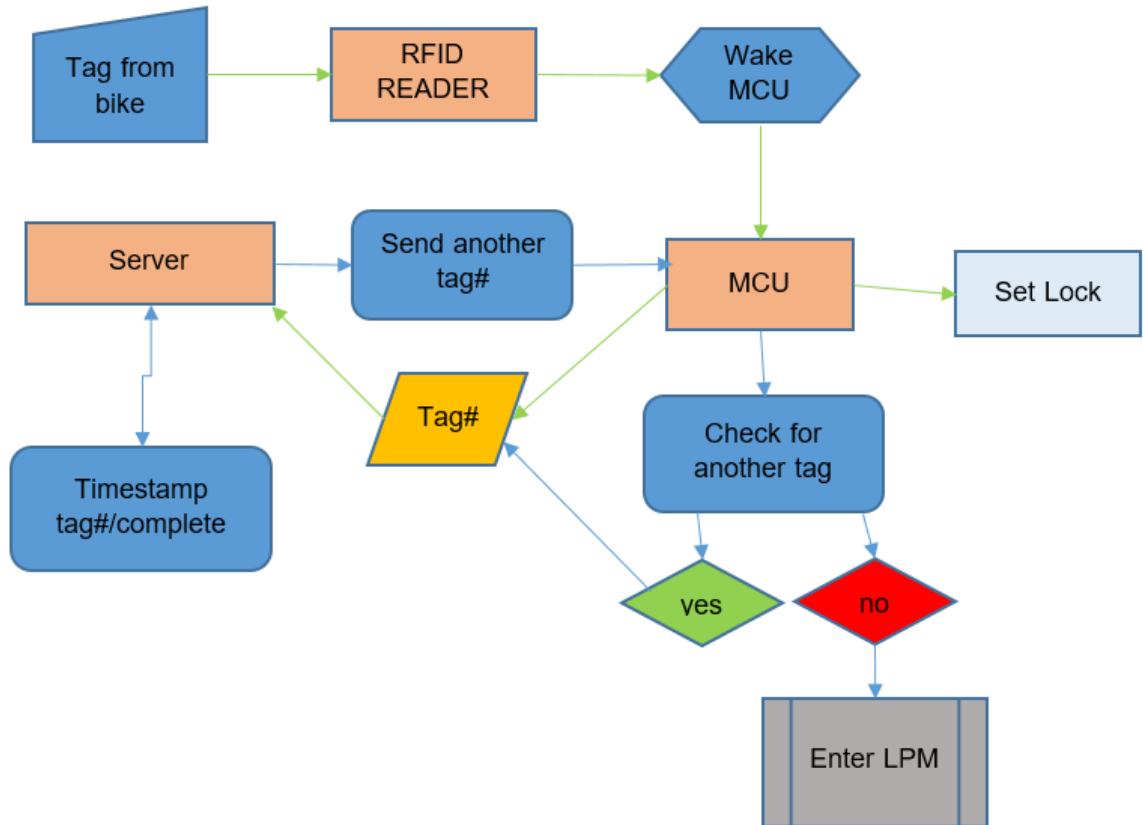

Figure 7.4.1.6 - RFID and MCU Interface

*Magnetic card reader to MCU*

When a user wishes to rent a bike or charge a bike, they will need to validate their UCF student account. This will require the use of a magnetic card reader to read the ISO number from each student identification card. Fortunately, UCF only stored information on the first track, so having to dig through the bits on the second and third will not be necessary.

However, data will need to be transmitted and received from both the card reader and the MCU to the server. When the user swipes their UCF id, the MCU will read the incoming data, starting with a sentinel bit “%”. This is industry standard. Next, the program will have to grab the ISO number and hold it in memory until the tag of the bike is entered in the system. Together, this information will then be sent to the server to be time stamped and stored for the initial time. The return time is determined upon the following input from the tag when it is returned, discussed in the RFID to MCU section above. Diagram XX illustrates the following flow of data between the magnetic card and MCU.

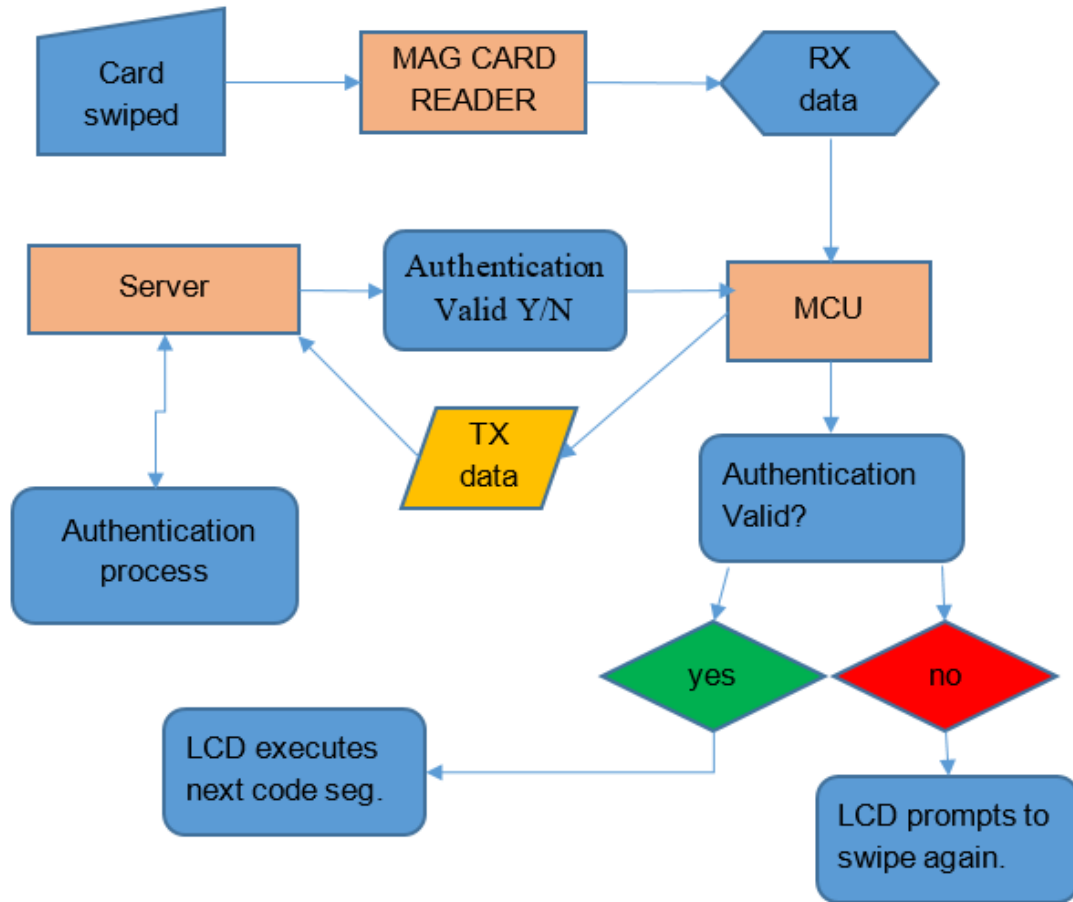

Figure 7.4.1.7 – Magnetic Card Reader and MCU Interface

*LCD screen to MCU*

The LCD screen will be powered by the “”booster pack and will be the main interrupt to the MCU. A simple touch will wake the screen and the MCU, which will in turn wake the magnetic card reader. This will be done with an interrupt service routine (ISR). The LCD screen will have the following commands layered, seen in the high-level software diagram. The MCU will wait for either a signal coming from magnetic card reader or a signal from the LCD touch screen. If the subsequent signal after the wake is data from card reader, the MCU will execute the **data\_From\_Id** module and complete the transaction for the user. If the MCU receives **no\_data** from the LCD screen, this means that the user stopped working with the system and the system needs to return to LPM and power down. Once the transaction is complete, the MCU will wait 2 minutes for more data to be sent to the MCU

(meaning someone swiped their UCF id again and wishes to rent a bike). If no data is received from the magnetic card reader after this time, the MCU will power down and the LCD screen will power down (as it will assume no one is in front of it). The following diagram 7.4.1.8 illustrates the interaction.

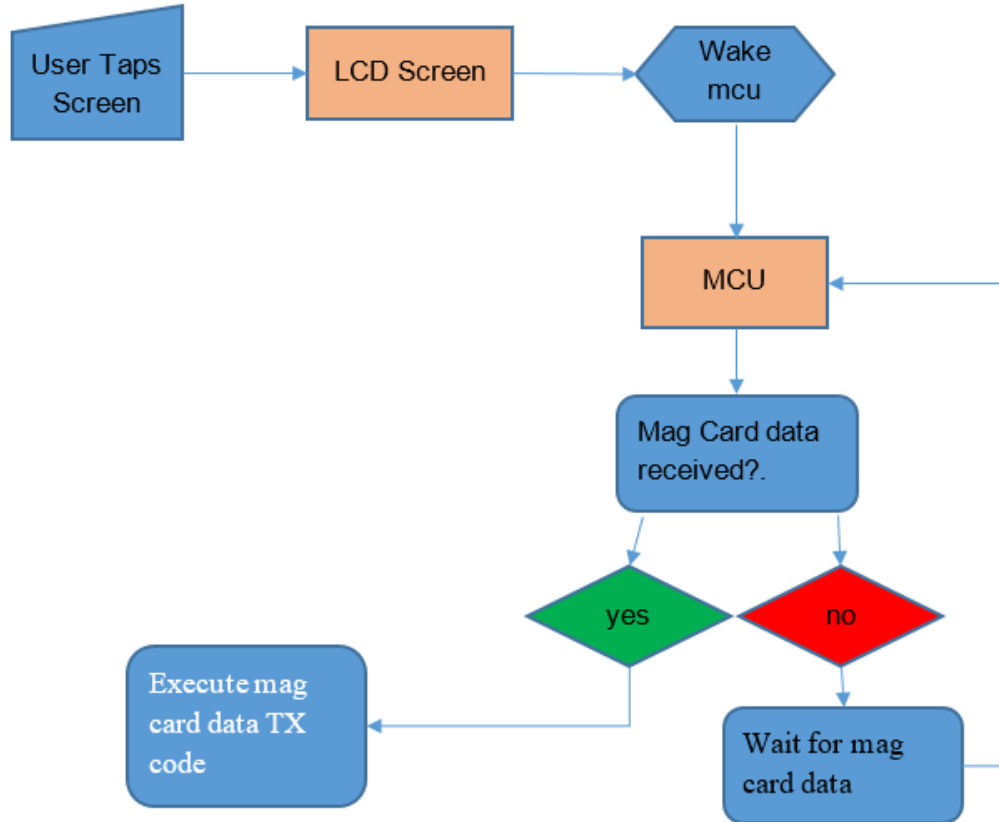

Figure 7.4.1.8 – LCD Screen and MCU Interface

#### 7.4.1.1. LCD screen

The LCD screen chosen was the TI Stellaris LCD Module Boosterpack. It is a low power module, requiring on 3.3V and contains a constant current booster to power the LCD touch screen. The development environment will be the same as the main MCU, Code Composer Studio.

#### 7.4.2. Security Camera Embedded System

The routine for the camera system will be work similarly as the one for the lighting system, being activated when motion is sensed and thus the microcontroller wakes up from low power mode. It will start filming the surroundings when it wakes up.

The memory will continually be checked to see if it's full. If, during the process of filming, the external hard drive happens to become full, chunks of the oldest data will be deleted to make room for more. It will then continue to film its surroundings. Once no motion has been detected for one minute, the microcontroller will go into low power mode. Another

possibility is that the program does not see that the memory is full until it is already in low power mode. If that is the case, the microcontroller will wake up, delete chunks of the oldest data, and promptly go back into low power mode. This process is shown graphically below in Figure 7.4.2.

The video footage will be deleted based on increments of time. The oldest one-hour chunk will be deleted from the hard drive as the memory becomes full. After the first time the memory becomes full with the full 40 hours of footage, this process will be repeated for every hour of video footage completed.

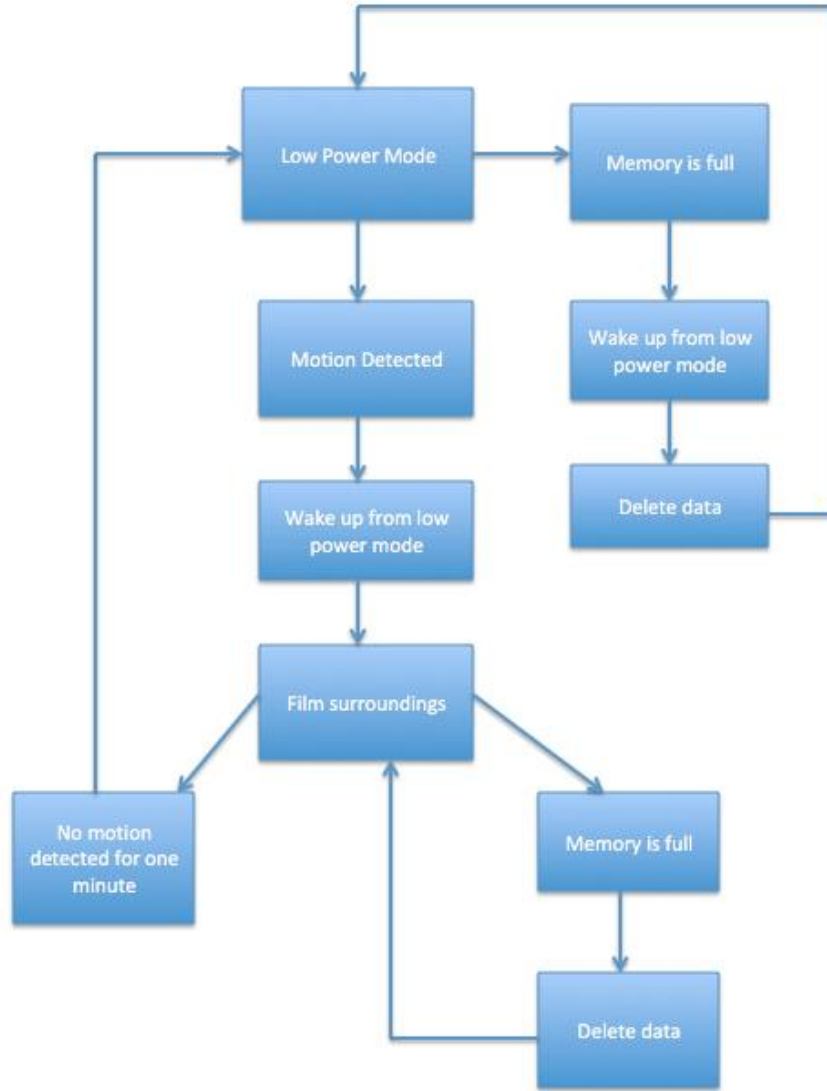

Figure 7.4.2 – Security Camera Software Block Diagram

### 7.4.3. Lighting System Embedded System

The MCU will start off in low power mode when no one is around. When it senses that someone is near, the MCU will wake up and begin to run the routine for the lights, while also running the routine for the camera.

After it wakes up, it will communicate with the RTC to see if it is between 6:00 PM and 6:00 AM. If it is between those times, then a pulse will be sent to the relay to turn on the LED strip. If it is not between those times, then nothing happens. The MCU will continue to stay alert until one minute has passed without motion. If the lights were previously on, after it notices that no motion has been detected for one minute, it will shut off the lights before entering low power mode. Figure 7.4.3 below shows a graphical representation of what the code will be doing

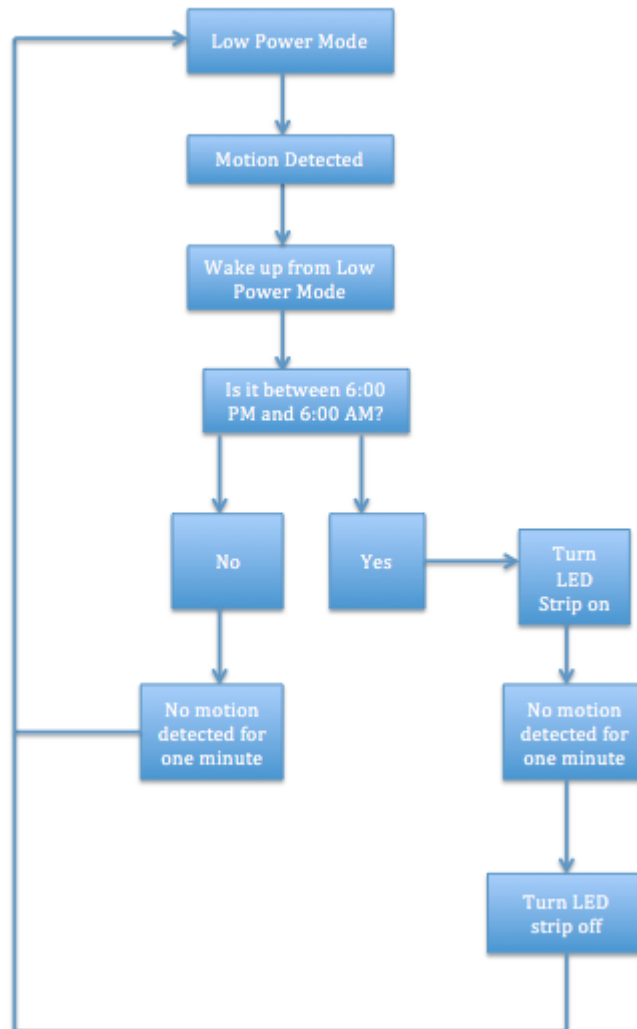

Figure 7.4.3 – Light Control Software Block Diagram

#### 7.4.4. MPPT Software Structure Design and Programming Language

The maximum power point tracking program is written and provided by the Texas Instrument engineers. This maximum power point tracking algorithm is designed by on the “perturb and observe” method. In this method, the sensed voltage data and the sensed current data will be fed to the microcontroller which wi through the code loop to check for the maximum power. The figure 7.4.4 shows the block diagram of this algorithm.

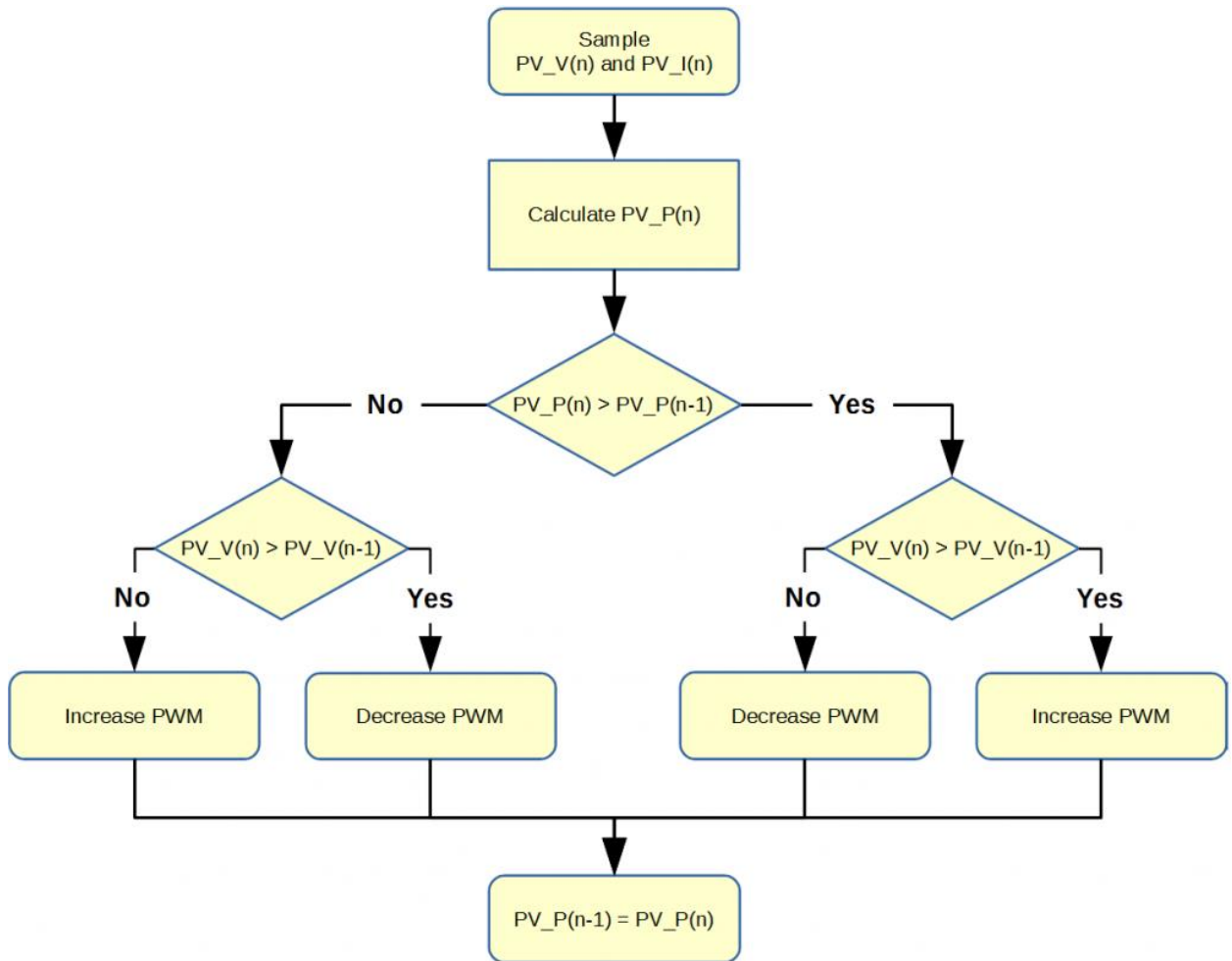

Figure 7.4.4 - “Perturb and Observe” Algorithm Block Diagram

Even though this algorithm is being written, the code needs to be adjusted based on the design of our project. We have to run through a test after the PCB board of the actual MPPT charge controller is made.

---





## 8.2. Facilities and Equipment

A list of facilities and equipment that the team will use in order to successfully implement and test the product. The facilities and equipment are based on cost and availability. For the most part, we will be using the various facilities offered at UCF.

- UCF Idea Lab
- UCF TI Lab
- UCF Senior Design Lab
- UCF SmartLab

The following table provides the equipment used at all of these locations.

Table 23 – Equipment List

## 8.3. Hardware Implementation

The following section will outline the planned implementation of the projects hardware components and various interfaces.

### 8.3.1. Power System Implementation

#### 8.3.1.1. Charge Controller

For this step, we will apply the charge controller to the system once it is done with testing.

We will wait for a sunny day where we expect the sky is clear so we can test for the maximum performance from the charge controller.

However, we may have to take into consideration of the fact that the power produced never meet its max point due to its nonideal condition as well as the temperature. The temperature may degrade some of the electrical component inside the charge controller which reduce its full potential performance.

#### 8.3.1.2. DC-to-DC Converter

After building the PCB for all five of the supply DC-DC converter circuit, we will connect them as seen in the block diagram to the load. Depend on the current rating of

each load, we will select the wiring size of the conducting wire to make sure it will reduce the power loss during transmission.

Once we connect all the components correctly, we will use the multimeter to test for the current and voltage to make sure it does not have any short circuit or open circuit.

### **8.3.1.3. DC-to-AC Converter**

The implementation of two main voltage converters have certain steps. First, components are put on breadboards in order to ensure the schematic function correctly. Any glitches or inaccurate outputs due to appropriate value are considered. Because the schematics, which were tested by being run in a simulation program, are correct, the error may come from individual part itself and then can be replaced by different one on breadboard. After the design work well on the breadboard, the PCB board are ordered. Then, all the components are soldered on the PCB for stability and professional look. Completed PCB boards are wired to power supply and loads. The inverters are screwed into a box to protect from external conditions.

The DC-to-DC converters are built mainly from four voltages regulator LM7809, LM7806, LM7805 and LM313. The LM780x input pin are sourced to the battery bank through a 2A relay while the LM313 input pin are connect to output of LM7805 because of its limitation of input. We then test the output of each by connect them to a 12V LED strip and multi-meter. Heat sinks are also considered if the current loads are high. More soldering task may be needed to attach those sinks.

The DC-to-AC converters are more difficult and requires more work. Each block of the circuit need to be constructed step by step and measured right away to make sure the output are proper. The first function block to be constructed is the sine wave and triangular-wave oscillator. Both of those are directly sourced from the 6V output of LM7806 of DC-to-DC converter. Those oscillators can be constructed at the same time because they work independently. Since the accuracy of frequency, phase and amplitude of their outputs will be effect the Pulse-Width Modulation signal, they need to be precise. We spend more time to test and replace the best value of resistor and capacitor in order to achieve the best result. Next step, the sine-wave signal is routed to a non-inverting amplifier to ensure it gets correct amplitude. The amplified sine-wave signal and the carrier signal are routed to comparator to construct PWM signal.

After the proper PWM signal are generated, the two MOSFETs drivers are implemented on the board following by four n-channel MOSFETs. The four MOSFETs make an H-bridge MOSFETs configuration are controlled on and off by the MOSFETs drivers. The process of turning MOSFETs as switches in difference certain amount of time create a fine sinusoidal waveform at 60Hz output.

The final function block to be constructed is the low pass filter. The 2 poles low-pass filter ensure that the output remain at 60Hz or it could be harmful to the load. The output then be fed to a step up transformer to the desired voltage of 110V. Wires are routed to A/B type electric outlet. The output is ready to be tested.

While the circuit are built and tested on the breadboard, the PCB board is ordered. The design of PCB board in Appendix # is drawn by Eagle PCB program. After the PCB board is received, all the components on breadboard can be transfer onto the PCB and soldered. The full design for the PCB board are demonstrated in Appendix #. The advantage of implement the design on a PCB board is to get rid of all the extra wires and the possibility of any extra noise that can be attributed to the length or crossing of wires typical on a breadboard. Also, the PCB board make the circuit neater and more presentable.

Finally, after two PCB boards, one DC-to-DC and one DC-to-AC, are implemented correctly and provide precise voltage. The boards are wired to the battery bank as well as electric outlet. Both of them are screwed into a box for protection and easy maintain.

### **8.3.2. Locking Mechanism**

The implementation of locking mechanism involves most mechanical tasks in the KnightRyder Station. All of our team members are majored in Electrical Engineering so we have to seek for help from UCF Mechanical Engineering Department to construct the locking system. In our project, the prototype has only two locks demonstrating Personal and Rental locks and the number of locks could be added more when the design are built widely.

The V-rods are made from metal with the length of sides are 4 and 6 inches. Two side made an angle of 70.5 degree. The end of the longer side was screwed to clench the V-rod so it could rotate. Three hooks are then soldered on the long side. A pull type solenoid is attached to one hook while two springs are attached to the other two.

There are two wood boxes with frames inside are built. The boxes covers the locks and hold the bikes stable. Then, the rods, solenoids and springs are nailed on frame. We make enough space to let the V-rod pulled properly. Finally, the solenoids are wired to the battery and the MCU pin to run it as requested.

### **8.3.3. RFID and Magnetic Card Reader**

The RFID and Magnetic Card Reader will both operate via USB. In order to implement them into the system, an FTDI chip will be required for both. An FTDI chip is crucial because it allows the USB to be interfaced with the MCU and allows transmission of readable data for the MCU to obtain. To implement it onto the board, the input of the FTDI chip will connect directly with the magnetic card reader and the output connected to I2C\_SDA pin (refer to appendix [xx]).

## **8.4. Software Implementation**

*MCU Implementations* - All MCU's will be programmed using TI Code Composer and written in C. Although C++ is higher level than C and easier to code in, the reason we chose not to use C++ is that objects may have a tendency to become to large, eating up

memory space, a characteristic which is not ideal when dealing with embedded systems. The other main reason is the main MCU, TI CC3200 SimpleLink, will simply be a mediator between data and utilizing ISR's make the MCU more power efficient and less taxing with time delay and hence, C was the preferred programming language chosen.

To develop the user interface, TI Stellaris Launchpad will be the direct interface to the LCD screen and supply ISR's to the CC3200 when required. The user interface will be implemented upon the various graphics library that TI offers for the Stellaris Launchpad and the main use of widgets will make the interface simple and clean.

The embedded software will go through various test methods, first initializing the MCU and system and making sure the hardware is working properly on the launch pads. Second, the hardware from the external devices are communicating properly and third, verifying the wireless internet connection is successful. Once these foundational steps are completed, the source code will be written in incremental steps, completed specific tasks that relate to the flow diagrams. The final implementation step is to burn the program onto the CC3200, which will be on the developed PCB and encased.

There will also be website for administrative purposes to verify and log correct usage of the system. This will be implemented using a Parse account, which was provided to us free of charge. The ability to have access to Parse is crucial as it eliminates the need to develop our own server software/website and/or pay for a host server. Parse also allows the administrators the ability to implement a mobile application in possible phase two development and already have a working platform to work with.

*Security Camera and Lighting System Implementation* - The MCU for the lighting and camera system will be in low power mode when motion is not detected. The motion sensor will constantly be operating, and will send a signal that will thus wake the MCU up from low power mode and begin other operations. The code will be constantly looping, checking for motion. When the motion is detected, the code will run an if and if else statement checking if the lights should turn on or not by checking the time on the MCU's RTC. Another segment of code will activate the camera. When this is done, it will go into another routine where it will check if the motion hasn't been detected for one minute. The time of when the motion was initially detected is compared to the current time, and the MCU goes back into low power mode once there is a one minute difference between the two. If motion is detected during the process, the new current time is saved and that particular process starts over.

---

## **9. Prototype Testing**

The following section will overview the various testing and procedure methodology derived to ensure the project implementation is successful and to debug any errors that may occur in the software and/or repurchase parts and execute correct troubleshooting hardware methods.

### **9.1. Hardware Specific Testing**

### **9.1.1. MPPT Charge Controller Testing**

After the charge controller being designed and being built, it then will be tested to see if it works for the system. For now, we will only list the steps that we will do to test the device since we still not have the device with us yet.

When the device is made, it will be tested inside the lab where we will apply DC power supply device to the charge controller and measure its performance. We will hook up one terminal of the charge controller (the photovoltaic terminal) to the DC power supply, and we hook another terminal of the charge terminal (the battery terminal) to the 12V battery storage system that we have. The test will contain three parts: over charge test, under charge test, and maximum power tracking test. Also, we will check for the power performance based on these systems by observing the data from the computer interface software which is provided by TI

### **9.1.2. Data Reading Program (Graphical User Interface GUI PMP7605)**

This software provides the real time monitoring system for the charge controller. We can observe the performance of the panels, the charge controller, and the battery system at the same time. In the commercial charge controller, there is always a small LCD screen attached to the charge controller to display the reading value from the solar panel and the batteries. For this reference design circuit, there is no LCD screen monitor system option to track for real time performance of the charge controller. In order to do so, either we connect a computer directly to the system or we can use the clamp on multimeter or any type of electrical measurement device.

The figure 9.1.2 below shows the interface of the software:



Figure 9.1.2 - Graphical User Interface  
(Pending Permission from Texas Instrument)

### 9.1.3. Connection between the Hardware and the GUI (graphic user interface)

Since we have the microprocessor in our device, we have to download the software into it in order for it to function properly. To do so, we have to connect the device to our computer by using the third party device: the launchpad. The launchpad has the JTAG terminal that can connect directly to the computer while the EMULATOR Collector pin can connect to the hardware device. The code will be generated based on the setting of the system.

### 9.1.4. Graphical User Interface Data Reading

After we connect the hardware device (the charge controller board) what we can expect to see will be similar to the image below. This is taken from the software which shows the data for the voltage, current of the battery and the solar panels. We can base on this graph data and determine whether the system performance is proper or not.

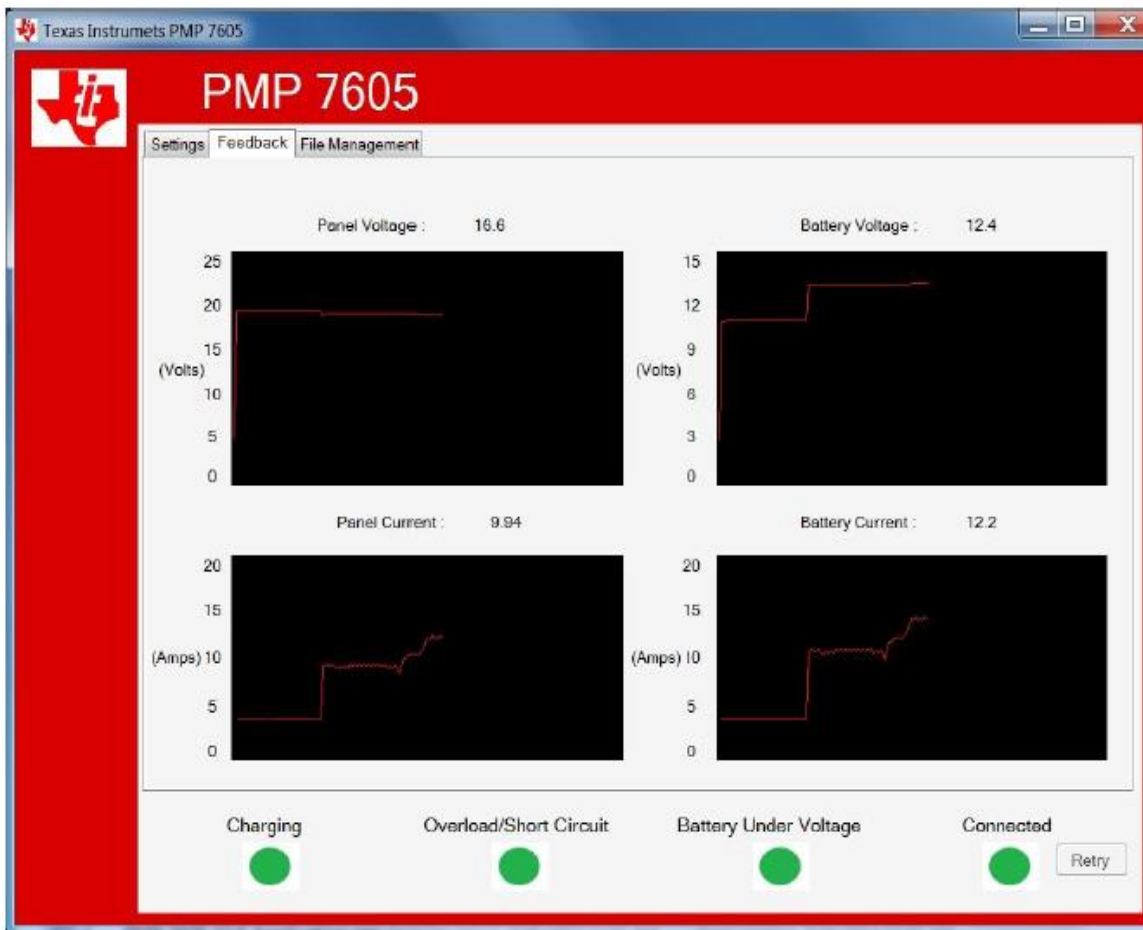

Figure 8.5.1.4 - Graphical Data Reading for PMP7605 Device  
(Pending Permission from Texas Instrument)

Panel Voltage: This graph shows the data of the real time update voltage generated from the solar panel device

Panel Current: This graph shows the data of the real time update voltage generated from the solar current device

Panel Voltage: This graph shows the data of the real time updated voltage coming out from the charge controller to the battery system.

Panel Current: This graph shows the data of the real time updated current coming out from the charge controller to the battery system.

### 9.1.5. Efficiency Test for the Charge Controller

The efficiency test of the charge controller is done by Texas Instrument engineers and is included in the document file of the PMP7605 device package.



The test procedure was that the input voltage from the DC power supply adjusted in the range from 17.70 to 17.19, Initially, the voltage value started off by 17.70V, and the current started entering the microcontroller. Measuring the output terminal (the battery terminal), it shows that the value of the voltage is regulated to 12V and the extra voltage value is converted into current value (this effect will boost the current rating to improve the battery charging condition).

Setting up: DC power supply: 15VDC, current limit sets to short circuit.

Below is the graphical test result by Texas Instrument engineer for the PMP7605 charge controller. This graph reflects based on the plot data below

Vi (V)	Ii (A)	Vo (V)	Io (A)	Pi (W)	Po (W)	Efficiency (%)
17.70	0.01	0.00	0.00	0.14	0.00	0.0
17.01	0.76	12.01	0.99	12.93	11.93	92.3
17.16	2.19	12.05	3.00	37.58	36.17	96.2
17.27	3.61	12.09	5.00	62.34	60.46	97.0
17.52	5.40	12.15	7.57	94.61	91.98	97.2
17.42	7.20	12.20	10.00	125.42	122.03	97.3
17.33	11.00	12.32	15.00	190.63	184.79	96.9
17.19	15.06	12.44	20.00	258.88	248.70	96.1

Table 24 - The manufacturer testing result for the PMP7605 Charge Controller

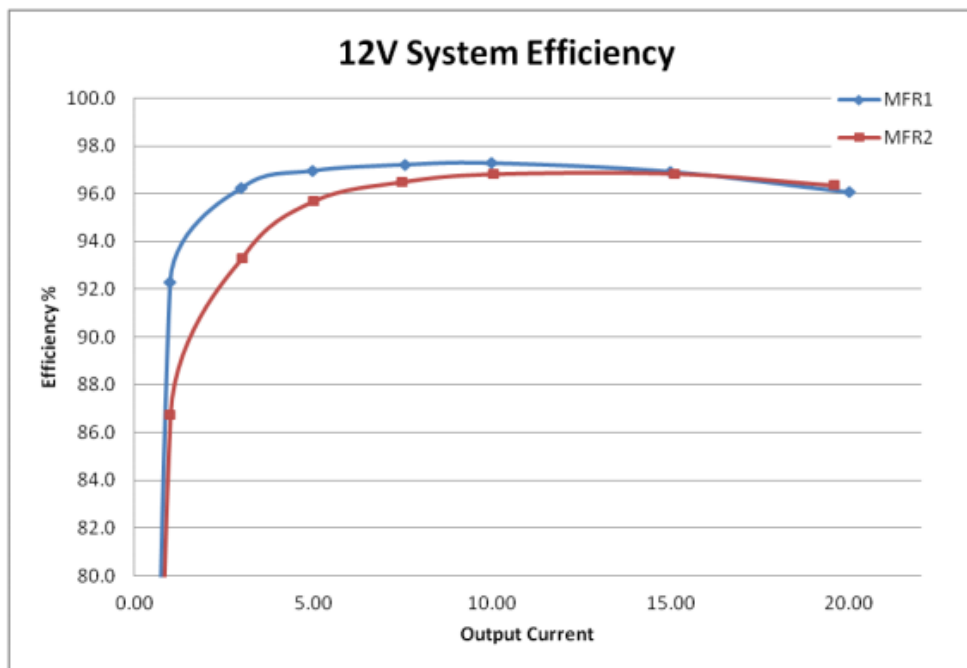

Figure 9.1.5: MPPT Charge Controller Efficiency Test (Courtesy of Texas Instrument)

### 9.1.6. DC-DC Converter Testing

Test for Supply #1 and Supply #2

<b>TEST OBJECTIVE:</b>	<b>DC-To-DC Converter from 12V-to-12V with current limited at 13.0A</b>																		
<b>TEST CONDITIONS:</b>	<ul style="list-style-type: none"> <li>• For Load#1 Check if the output voltage = 12V Check if the output current = 10A</li> <li>• For Load#2 Check if the output voltage = 12V Check if the output current = 3A</li> </ul>																		
<b>PROCEDURE:</b>	<ul style="list-style-type: none"> <li>• Using the Power Supply Bench connect to the supply terminal of the circuit where the DC input placement</li> <li>• Set the DC Power Supply: 14.5 ~ 14.9</li> <li>• <b>Test 1 – Check for the voltage value</b></li> <li>• Take the probe from the Digital Multimeter, the positive terminal of the probe at the output terminal, the negative terminal of the probe place at the ground.</li> <li>• Observe and take note for the DC voltage result.</li> <li>• <b>Test 2 – Check for the current value</b></li> <li>• Take an 1K resistor act as the load</li> <li>• Apply the KirchOff Law Formula to find the current value</li> <li>• <math>I = \frac{V}{1000\Omega}</math></li> </ul>																		
<b>RESULTS:</b>	<p>The result will be collected from the digital multimeter</p> <table border="1" data-bbox="610 1430 1417 1606"> <thead> <tr> <th data-bbox="610 1430 812 1503">Input Voltage</th> <th data-bbox="818 1430 1019 1503">OutPut Voltage</th> <th data-bbox="1026 1430 1227 1503">Output Current</th> <th data-bbox="1234 1430 1417 1503">Power</th> </tr> </thead> <tbody> <tr> <td data-bbox="610 1507 812 1539">10V</td> <td data-bbox="818 1507 1019 1539"></td> <td data-bbox="1026 1507 1227 1539"></td> <td data-bbox="1234 1507 1417 1539"></td> </tr> <tr> <td data-bbox="610 1543 812 1575">14.5V</td> <td data-bbox="818 1543 1019 1575"></td> <td data-bbox="1026 1543 1227 1575"></td> <td data-bbox="1234 1543 1417 1575"></td> </tr> <tr> <td data-bbox="610 1579 812 1610">16V</td> <td data-bbox="818 1579 1019 1610"></td> <td data-bbox="1026 1579 1227 1610"></td> <td data-bbox="1234 1579 1417 1610"></td> </tr> </tbody> </table>			Input Voltage	OutPut Voltage	Output Current	Power	10V				14.5V				16V			
Input Voltage	OutPut Voltage	Output Current	Power																
10V																			
14.5V																			
16V																			

Table 24 - Test for Supply #1 and Supply #2

*Test for Supply #3*

<b>TEST OBJECTIVE:</b>	<b>DC-To-DC Converter from 12V-to-3.7V with regulated current of 0.05A</b>																		
<b>TEST CONDITIONS:</b>	Check if the output voltage = 3.7V Check if the output current = 0.05																		
<b>PROCEDURE:</b>	<ul style="list-style-type: none"> <li>• Using the Power Supply Bench connect to the supply terminal of the circuit where the DC input placement</li> <li>• Set the DC Power Supply: 14.5 ~ 14.9</li>   <li>• <b>Test 1 – Check for the voltage value</b></li> <li>• Take the probe from the Digital Multimeter, the positive terminal of the probe at the output terminal, the negative terminal of the probe place at the ground.</li> <li>• Observe and take note for the DC voltage result.</li>   <li>• <b>Test 2 – Check for the current value</b></li> <li>• Take an 1K resistor act as the load</li> <li>• Apply the KirchOff Law Formula to find the current value</li> <li>• <math>I = \frac{V}{1000\Omega}</math></li> </ul>																		
<b>RESULTS:</b>	The result will be collected from the digital multimeter <table border="1" style="width: 100%; border-collapse: collapse;"> <thead> <tr> <th style="text-align: center;">Input Voltage</th> <th style="text-align: center;">OutPut Voltage</th> <th style="text-align: center;">Output Current</th> <th style="text-align: center;">Power</th> </tr> </thead> <tbody> <tr> <td style="text-align: center;">10V</td> <td></td> <td></td> <td></td> </tr> <tr> <td style="text-align: center;">14.5V</td> <td></td> <td></td> <td></td> </tr> <tr> <td style="text-align: center;">16V</td> <td></td> <td></td> <td></td> </tr> </tbody> </table>			Input Voltage	OutPut Voltage	Output Current	Power	10V				14.5V				16V			
Input Voltage	OutPut Voltage	Output Current	Power																
10V																			
14.5V																			
16V																			

Table 25 - DC-DC Converter Test for Supply #3

DC-DC Converter Test for Supply #4

<b>TEST OBJECTIVE:</b>	<b>DC-To-DC Converter from 12V-to-12V with current limited at 13.0A</b>		
<b>TEST CONDITIONS:</b>	<ul style="list-style-type: none"> <li>• For Load#1 Check if the output voltage = 3.3V Check if the output current = 0.75A</li> <li>• For Load#2 Check if the output voltage = 3.3V Check if the output current = 0.3A</li> </ul>		
<b>PROCEDURE:</b>	<ul style="list-style-type: none"> <li>• Using the Power Supply Bench connect to the supply terminal of the circuit where the DC input placement</li> <li>• Set the DC Power Supply: 14.5 ~ 14.9</li> <li>• <b>Test 1 – Check for the voltage value</b></li> <li>• Take the probe from the Digital Multimeter, the positive terminal of the probe at the output terminal, the negative terminal of the probe place at the ground.</li> <li>• Observe and take note for the DC voltage result.</li> <li>• <b>Test 2 – Check for the current value</b></li> <li>• Take an 1K resistor act as the load</li> <li>• Apply the KirchOff Law Formula to find the current value</li> <li>• <math>I = \frac{V}{1000\Omega}</math></li> </ul>		
<b>RESULTS:</b>	<b>The result will be collected from the digital multimeter</b>		
	<b>Input Voltage</b>	<b>OutPut Voltage</b>	<b>Output Current</b>
	<b>10V</b>		
	<b>14.5V</b>		
	<b>16V</b>		

Table 25 - Test for Supply #4

*DC-DC Converter Test for Supply #5*

<b>TEST OBJECTIVE:</b>	<b>DC-To-DC Converter from 12V-to-5V with current limited at 1.4 A</b>		
<b>TEST CONDITIONS:</b>	<ul style="list-style-type: none"> <li>• For Load#1 Check if the output voltage = 5.0V Check if the output current = 0.7A</li> <li>• For Load#2 Check if the output voltage = 5V Check if the output current = 0.7A</li> </ul>		
<b>PROCEDURE:</b>	<ul style="list-style-type: none"> <li>• Using the Power Supply Bench connect to the supply terminal of the circuit where the DC input placement</li> <li>• Set the DC Power Supply: 14.5 ~ 14.9</li> <li>• <b>Test 1 – Check for the voltage value</b></li> <li>• Take the probe from the Digital Multimeter, the positive terminal of the probe at the output terminal, the negative terminal of the probe place at the ground.</li> <li>• Observe and take note for the DC voltage result.</li> <li>• <b>Test 2 – Check for the current value</b></li> <li>• Take an 1K resistor act as the load</li> <li>• Apply the KirchOff Law Formula to find the current value</li> <li>• <math>I = \frac{V}{1000\Omega}</math></li> </ul>		
<b>RESULTS:</b>	<b>The result will be collected from the digital multimeter</b>		
	<b>Input Voltage</b>	<b>OutPut Voltage</b>	<b>Output Current</b>
	10V		
	14.5V		
	16V		

Table 26 - Test for Supply #5

**9.1.7. TICC3200 Hardware Interface Testing**

The following test objectives and conditions are for the TICC3200 SimpleLink Wifi MCU connected and tested between the magnetic card reader, host server, LCD Touch Screen, and RFID Reader

<b>TEST OBJECTIVE:</b> Ensure reset button for MCU is working
<b>TEST CONDITIONS:</b> TICC3200 Launchpad connected to computer and booted.
<b>PROCEDURE:</b> <ol style="list-style-type: none"> <li>1. Load a few registers with data</li> <li>2. Press Reset button</li> <li>3. Run debugger and check registers in Code Composers, they should be empty.</li> </ol>
<b>RESULTS:</b> N/A

Table 27

<b>TEST OBJECTIVE:</b> Wireless communication between mcu and server
<b>TEST CONDITIONS:</b> TICC3200 Launchpad connected to computer and booted
<b>PROCEDURE:</b> <ol style="list-style-type: none"> <li>4. Following TI protocol to configure the COM port of the TICC3200</li> <li>5. Load the WLAN station project, and change the baud rate to 115200</li> <li>6. MCU will ping the appropriate IP to the host server/website we are trying to connect to</li> <li>7. Successful connection will light LED on Launchpad</li> </ol>
<b>RESULTS:</b> N/A

Table 28

<b>TEST OBJECTIVE:</b> Achieve successful interrupt when user touches LCD Screen
<b>TEST CONDITIONS:</b> TICC3200 Launchpad connected to computer in Low Power Mode and LCD screen boosterpack
<b>PROCEDURE:</b> <ol style="list-style-type: none"> <li>1. Touch LCD screen to wake</li> <li>2. LCD booster will send interrupt to MCU</li> <li>3. MCU will print to Hyperterminal, "I am awake" if interrupt signal successful</li> </ol>
<b>RESULTS:</b> N/A

Table 29

<b>TEST OBJECTIVE:</b> Ensure correct magnetic card information is read
<b>TEST CONDITIONS:</b> TICC3200 Launchpad connected to computer, Hyperterminal and magnetic card reader
<b>PROCEDURE:</b> <ol style="list-style-type: none"> <li>1. Swipe magnetic card through reader</li> <li>2. MCU will pull specific data only needed</li> <li>3. MCU will print this data to Hyperterminal</li> </ol>
<b>RESULTS:</b> N/A

Table 30

<b>TEST OBJECTIVE:</b> Ensure data sent from MCU to host server
<b>TEST CONDITIONS:</b> TICC3200 Launchpad connected to computer, Hyperterminal and magnetic card reader
<b>PROCEDURE:</b> <ol style="list-style-type: none"> <li>1. Swipe magnetic card through reader</li> <li>2. MCU will pull specific data only needed</li> <li>3. MCU will print this data to Hyperterminal</li> <li>4. MCU will send data to server.</li> <li>5. LED will blink to signal transmission to server was executed.</li> <li>6. Server will display data.</li> </ol>
<b>RESULTS:</b> N/A

Table 31

<b>TEST OBJECTIVE:</b> Ensure correct RFID tag information is read and sent to server
<b>TEST CONDITIONS:</b> TICC3200 Launchpad connected to computer, Hyperterminal and RFID reader
<b>PROCEDURE:</b> <ol style="list-style-type: none"> <li>1. Tap tag to RFID Reader</li> <li>2. MCU will pull specific data only needed</li> <li>3. MCU will print this to the hyperterminal</li> </ol>
<b>RESULTS:</b> N/A

Table 32

### 9.1.8. Lighting and Security Testing

The following procedures are made to test the major components and major operations of the lighting and camera system. In implementation, the lighting and camera subsystems act together as one. They have many interacting parts that contribute to both of their operations. It will be important to consider multiple interactions between different components. By isolating these different interactions, we can see possible problems that may arise and takes steps to make sure that they do not negatively effect the project.

The test in Table 33 below outlines the best way to see if the motion sensor is working. It is important to test the motion sensor's response to motion at a variety of distances to make sure that it stays responsive or is too responsive if a something like an animal staying near it makes it trigger very often.

<p><b>TEST OBJECTIVE:</b> See how the motion sensor reacts to objects at different distances to consider if additional design precautions need to be taken into consideration to account for environmental variables.</p>
<p><b>TEST CONDITIONS:</b> If the motion sensor is able to accurately detect motion of up to 2 meters away and can sense it within an 120 degree cone, it is operating properly and sufficient sensitivity for our project.</p>
<p><b>PROCEDURE:</b></p> <ol style="list-style-type: none"> <li>1. Create a test program for the motion sensor that lights up an LED when it senses motions</li> <li>2. Test reaction to motion with object moving right in front of it; use hand as moving object. Record your observations.</li> <li>3. Repeat step 2 five times to gather sufficient data at that distance.</li> <li>4. Test reaction to motion with object 30 cm from it; use a person as moving object. Record your observations.</li> <li>5. Repeat step 4 five times to gather sufficient data at that distance.</li> <li>6. Test reaction to motion with object 1 m from it; use a person as moving object. Record your observations.</li> <li>7. Repeat step 6 five times to gather sufficient data at that distance.</li> <li>8. Test reaction to motion with object 2 m from it; use a person as the moving object Record your observations.</li> <li>9. Repeat step 8 five times to gather sufficient data at that distance.</li> </ol>
<p><b>RESULTS:</b> N/A</p>

Table 33 - Motion sensor functionality test

Both Table 34 and 35 detail the procedures to determine if the relay is functioning correctly. It is separated into two parts so that we can carefully examine how the switch part of the relay behaves and how the relay connects to the main circuit.

<p><b>TEST OBJECTIVE:</b> See if the relay switches properly.</p>
<p><b>TEST CONDITIONS:</b> If we can hear the relay click, we can confirm the switch part of the relay is operating properly.</p>
<p><b>PROCEDURE:</b></p> <ol style="list-style-type: none"> <li>1. Apply a 12VDC voltage source across the two coil terminals. Listen for a click.</li> <li>2. Remove the voltage source and make listen to make sure the switch opens</li> <li>3. Repeat step 1 and 2 five times to gather sufficient data.</li> </ol>
<p><b>RESULTS:</b> N/A</p>

Table 34 - Relay switching test



Table 35 details the procedure for making sure the switching mechanism in the relay closes fully so that it may complete the circuit to turn on the light strip.

<b>TEST OBJECTIVE:</b> See that when the relay switches when the LED strip is attached to it that it can light up the LED strip.
<b>TEST CONDITIONS:</b> If we can get the LED strip to light up when the relay switches, we can confirm that the relay is able to properly give power to the LED strip.
<b>PROCEDURE:</b> <ol style="list-style-type: none"> <li>1. Apply a 12VDC voltage source across the two coil terminals of the relay. Connect the LED strip to the normally open terminal. Supply 12 volts to the common terminal.</li> <li>2. Detach everything connect to the relay and repeat step 1 five times to gather sufficient data.</li> </ol>
<b>RESULTS:</b> N/A

Table 35 - Relay with LED strip test

Table 36 details the process that will ensure we know that the camera can interact with the code and record footage as we want.

<b>TEST OBJECTIVE:</b> See that the camera records footage.
<b>TEST CONDITIONS:</b> If the camera is able to record footage and that data can be found on the external hard drive, we can see that it is properly recording.
<b>PROCEDURE:</b> <ol style="list-style-type: none"> <li>1. Create a test program that makes the camera film for set a period of time of one minute and saves the footage to the external hard drive.</li> <li>2. Connect the external hard drive to a computer and see if it filmed for the full duration of that one minute, and only for that long.</li> <li>3. Repeats steps 1 and 2 five times to gather sufficient data.</li> </ol>
<b>RESULTS:</b> N/A

Table 36 – Camera footage test

The procedure outlined in Table 37 details the procedure that lets us know that the LED strip is fully functional.

<b>TEST OBJECTIVE:</b> See that the LED strip lights up.
<b>TEST CONDITIONS:</b> If the entirety of the strip lights up when supplied power, it is operating correctly.
<b>PROCEDURE:</b> <ol style="list-style-type: none"> <li>1. Connect the LED strip to a 12VDC voltage source.</li> <li>2. Measure the current across the strip.</li> <li>3. Disconnect the LED strip from the voltage source. Repeat steps 1 and 2 five times to gather sufficient data.</li> </ol>
<b>RESULTS:</b> N/A

Table 37 - LED light strip test

Table 38 details how we can make sure that we have written a code that can accurately delete the portion of data that we want to delete from the external hard drive.

[I assume you will put Table 38 here]  
Table 38

*Collective testing of lighting and security system*

Table 39 consolidates all the previous tests for the lighting and camera system. We piece together and adjust codes that were previously written. There will be a lot more going on than in the previous tests, so it is important to carefully go through a make sure that each and every part is working correctly. The step by step instructions detailed helps us make sure that we did not miss anything in the testing process.

<b>TEST OBJECTIVE:</b> See that the whole system works together.
<b>TEST CONDITIONS:</b> If everything works together like it worked individually, the system is operating correctly.
<p><b>PROCEDURE:</b></p> <ol style="list-style-type: none"> <li>1. Set up the lighting and camera systems.</li> <li>2. Upload the code and run it.</li> <li>3. Make sure that it is nighttime so that the lights will turn on.</li> <li>4. Trigger the motion sensor by walking in front of it.</li> <li>5. Check if the lights turn on. Also check that the lights turn off approximately one minute after movement in front of the motion sensor has stopped. This will confirm that the RTC and the code knows it is nighttime and that the relay is operating properly.</li> <li>6. Remove the external hard drive and see if camera filmed what happened. Check that it filmed for approximately one minute after no movement.</li> <li>7. Repeat steps 4 through 6 five times to gather sufficient data.</li> <li>8. Make sure that is so that is daytime and the lights do not turn on.</li> <li>9. Trigger the motion sensor by walking in front of it.</li> <li>10. Make sure that the lights do not turn on. This will confirm that the RTC and the code knows that it is daytime.</li> <li>11. Repeat steps 8 through 10 five times to gather sufficient data.</li> </ol>
<b>RESULTS:</b> N/A

Table 39: Full lighting and camera system test

**9.1.9. DC-to-AC Converter Testing**

<b>TEST OBJECTIVE:</b> Test the output of DC-to-AC Converter is fine sinusoidal and able to deliver power for a AC-using device.
<b>TEST CONDITIONS:</b> Battery bank supply 12 VDC input. Desired output of converter is 110VAC and 60Hz
<p><b>PROCEDURE:</b></p> <ol style="list-style-type: none"> <li>1. Ensure the input of converter is 12VDC by measuring using multimeter.</li> <li>2. Measure the voltage output of converter.</li> <li>3. Oscilloscope is used to test the frequency of output.</li> </ol>

<ol style="list-style-type: none"> <li>4. After the step 2 and 3 results are correct, connect a fan or a phone charger to the converter.</li> <li>5. Check if the fan or phone charger operation normally</li> </ol>
<b>RESULTS:</b> N/A

Table 40 – DC-to-AC Converter Testing

<b>TEST OBJECTIVE:</b> Test the output of DC-to-AC Converter is able to charge an electric bike battery.
<b>TEST CONDITIONS:</b> Battery bank supply 12 VDC input. Desired output of converter is 110VAC and 60Hz. The connected electric bike battery is desired to be charge with minimum current of 5A
<b>PROCEDURE:</b> <ol style="list-style-type: none"> <li>1. Ensure the input of converter is 12VDC by measuring using multimeter.</li> <li>2. Measure the voltage output of converter.</li> <li>3. After the step 2 results are correct, connect a electric bike charger to the converter.</li> <li>4. Check if the output of that charger is match with its labeled value by using multimeter.</li> </ol>
<b>RESULTS:</b> N/A

Table 41 – DC-to-AC Converter Testing

#### 9.1.10. Locking Mechanism Testing

<b>TEST OBJECTIVE:</b> Test the operation of the lock when it receive signal from MCU
<b>TEST CONDITIONS:</b> Battery bank supply 12 VDC input. The lock receive signal from MCU to open the lock for 15 seconds. After 15 seconds , the lock go back to close positon
<b>PROCEDURE:</b> <ol style="list-style-type: none"> <li>1. Ensure the input of solenoid is 12VDC by measuring using multimeter.</li> <li>2. Arise a signal from MCU to open the lock</li> <li>3. Check if the solenoid is able to pull the rod from it close position.</li> <li>4. Check if the solenoid stay at that position for 15 seconds.</li> <li>5. Check if after 15 seconds, the solenoid is odd and the V-rod is pulled by the spring back to it close position.</li> </ol>
<b>RESULTS:</b> N/A

## 9.2 Software Specific Testing

The following section will overview the objectives and procedures for testing the software for the system to ensure proper operation.

### 9.2.1 Software Test Environment

The programmers will be using Code Composer Studio to develop the majority of the code to be run. To test the implementation code of the MCU's, the programmers will be using

UART and the Hyperterminal along. Once testing via Hyperterminal is completed, testing with the wireless connection to the Parse server will be crucial step in ensuring the COM ports are working properly and the system will be sufficient on it's own.

<b>TEST OBJECTIVE:</b> Ensure correct RFID tag information is read and sent to server This same procedure doubles for magnetic card information.
<b>TEST CONDITIONS:</b> TICC3200 Launchpad connected to computer and HyperTerminal
<b>PROCEDURE:</b> <ol style="list-style-type: none"> <li>1. The programmer will input random variables in UART</li> <li>2. MCU will reprint this data back to the HyperTerminal</li> </ol>
<b>RESULTS:</b> N/A

Table 43

<b>TEST OBJECTIVE:</b> Appropriate timestamp to mimick intial rental time
<b>TEST CONDITIONS:</b> TICC3200 Launchpad connected to computer and HyperTerminal
<b>PROCEDURE:</b> <ol style="list-style-type: none"> <li>1. The programmer will input random variables in UART</li> <li>2. MCU will reprint this data back to the HyperTerminal</li> <li>3. MCU will send this data to server</li> <li>4. Server will implement timestamp to confirm time data was received</li> </ol>
<b>RESULTS:</b> N/A

Table 44

<b>TEST OBJECTIVE:</b> Appropriate timestamp to mimick return time
<b>TEST CONDITIONS:</b> TICC3200 Launchpad connected to computer and HyperTerminal
<b>PROCEDURE:</b> <ol style="list-style-type: none"> <li>1. The programmer will input same random variables in UART</li> <li>2. MCU will reprint this data back to the HyperTerminal</li> <li>3. MCU will send this data to server</li> <li>4. Server will match the data to the original sent and connect the two</li> <li>5. Server will timestamp and close the account for the rental.</li> </ol>
<b>RESULTS:</b> N/A

Table 45

<b>TEST OBJECTIVE:</b> Authenticate user validity
<b>TEST CONDITIONS:</b> TICC3200 Launchpad connected to computer and HyperTerminal
<b>PROCEDURE:</b> <ol style="list-style-type: none"> <li>1. The programmer will store a name on server database</li> <li>2. Programmer will input name in UART in hyperterminal</li> <li>3. MCU will send this data to server</li> <li>4. Server will match received data to that on database</li> <li>5. If it is a match, will signal to mcu</li> <li>6. MCU will print to hyperterminal “match!”</li> <li>7. If it is not a match, server will send a different signal</li> <li>8. MCU will print to hyperterminal “not a match!”</li> </ol>
<b>RESULTS:</b> N/A

Table 46

<b>TEST OBJECTIVE:</b> Authenticate user validity on LCD Touch screen for a Match
<b>TEST CONDITIONS:</b> TICC3200 Launchpad connected to computer, server, hyperterminal, and LCD Touch Screen
<b>PROCEDURE:</b> <ol style="list-style-type: none"> <li>1. The programmer will store a name on server database</li> <li>2. Programmer will input name in UART in hyperterminal</li> <li>3. MCU will send this data to server</li> <li>4. Server will match received data to that on database</li> <li>5. If it is a match, will signal to mcu</li> <li>6. MCU will print to hyperterminal “match!”</li> <li>7. MCU will signal LCD to continue to the next screen</li> <li>8. LCD will continue executing the UI code</li> </ol>
<b>RESULTS:</b> N/A

Table 47

<b>TEST OBJECTIVE:</b> Authenticate user validity for NOT A MATCH
<b>TEST CONDITIONS:</b> TICC3200 Launchpad connected to computer and HyperTerminal
<b>PROCEDURE:</b> <ol style="list-style-type: none"> <li>1. The programmer will store a name on server database</li> <li>2. Programmer will input name in UART in hyperterminal</li> <li>3. MCU will send this data to server</li> <li>4. Server will match received data to data on database</li> <li>5. If it is not a match, server will send a different signal</li> <li>6. MCU will print to hyperterminal “not a match!”</li> <li>7. MCU will send signal to LCD Screen that user was not authenticated</li> <li>8. LCD screen will execute not_Authenticated code block and prompt user to try again</li> <li>9. Process repeats until user is authenticated or user walks away from system</li> </ol>
<b>RESULTS:</b> N/A

Table 48

<b>TEST OBJECTIVE:</b> Entering Low Power Mode
<b>TEST CONDITIONS:</b> TICC3200 Launchpad connected to computer, HyperTerminal, LCD Screen
<b>PROCEDURE:</b> <ol style="list-style-type: none"> <li>1. LCD low power mode code will be implemented for a 2 minute wait time</li> <li>2. If nothing happens, LCD screen will enter LPM and signal MCU to enter LPM</li> <li>3. MCU will print to hyperterminal “going to sleep, waiting for interrupts”</li> <li>4. MCU enters LPM.</li> </ol>
<b>RESULTS:</b> N/A

Table 49

<b>TEST OBJECTIVE:</b> Test that we can delete chunks of data from the external hard drive.
<b>TEST CONDITIONS:</b> If the section of data we want to be deleted is, we can see that we have coded this portion of the project properly.
<b>PROCEDURE</b> <ol style="list-style-type: none"> <li>1. Create a code that will delete the oldest video.</li> <li>2. Film two different one minute videos</li> <li>3. Run the code.</li> <li>4. Check to see if the proper video has been deleted.</li> <li>5. Repeat steps 2 through 4 five times to gather sufficient data.</li> <li>6. Adjust the code so that it detects that is full and deletes the oldest item.</li> <li>7. Fill up the external hard drive.</li> <li>8. Run the code.</li> <li>9. Check to see if the proper item has been deleted.</li> <li>10. Repeat steps 7 through 9 five times to gather sufficient data.</li> </ol>
<b>RESULTS:</b> N/A

Table 50 - Data deletion test

Table 51 test that we can set up the RTC correctly and that it keeps accurate track of time.

<b>TEST OBJECTIVE:</b> See that the set up RTC runs correctly.
<b>TEST CONDITIONS:</b> If the it runs correctly, the code will detect the difference between our division between turning the LEDS on and leaving the LEDs off.
<b>PROCEDURE</b> <ol style="list-style-type: none"> <li>1. Set up the RTC.</li> <li>2. Create a test code that reads the time on the real time clock, and compare that time to the time on another clock.</li> <li>3. Repeat step 2 fives times throughout different time in the day to gather sufficient data.</li> <li>4. Create a code that says the lights turn on at 6:00 PM to 6:00 AM when motion is sensed.</li> <li>5. Walk in front of the motion sensor to test between the hours of 6:00 PM and 6:00 AM and during the other half of the day. Check if it turns on when its supposed to and doesn't turn on when its supposed to.</li> <li>6. Repeat step 5 five times to gather sufficient data.</li> </ol>
<b>RESULTS:</b> N/A

Table 51 - RTC test

## **10. Maintenance**

### **10.1. Locking Mechanism Maintenance**

The locking mechanism does not require a regular maintenance. Since the solenoid is pull-type, it only consumes power to run when people insert or take the bike. All the other time, the solenoids remain at rest condition and do not produce heat due to electric current. We try to set up the operation time period be only ten to twelve second, just enough to take or insert the bike, so the solenoid could be cool all the time. On the other hand. The lock mechanism is protected by a wood box for external damage risk. If the system can be built broadly, a consideration of building the locks in a metal or heavy duty plastic box is highly recommended. The water resistible material will be the best choice to protect metal parts in the locking mechanism from flood and rain.

### **10.2. Power Distribution Maintenance**

Besides, the locking mechanism requires a maintenance for the V-rod annually. The risk when people try to pull the wheel will lead to bended rods. When a rod is bend or broken, the ability to secure the bike is decreased or lost.

The DC-to-DC converter requires a certain maintenance like twice a year or annually. Since the role of the DC-to-DC inverters are to provide the power for other devices, they are needed to function properly. The main requirement for this device is the temperature. Because the device use regulators as main parts. They easy to get heat up. Even though we have a test before install the device, the outside temperature in Florida could melt the heat sink on the devices. We recommend the device be install in a box and stay in the shade in order to avoid high temperature risk.

The DC-to-AC converter requires less maintenance. Because a surge protection is built in the design so most of issue of this converter usually come from outside elements. The electric outlets should be protected from flood and rain by installing a cover. The process to maintain the converter is simply done by using multi-meter to ensure the output voltage supplying is 110V.

---

## 11. Troubleshooting

Troubleshooting is always inherent when dealing with technology and multiple components operating simultaneously. Errors will occur and systems will stall or shut down. Therefore is standard to have a set of troubleshooting conditions when specific circumstances occur within the system. The following is a list of possible scenarios and solutions.

1. Batteries are dead.
  - a. Solution: Take multi-meter and read voltage across nodes. If the reading is below rated standard, attempt to charge the batteries with a deep cycle charger. If this is not successful, the purchase of a new battery will be required.
2. Touch screen is not working
  - a. Solution: Open system and power off. Confirm all wiring is snug and has not come loose. If wiring has come loose, readjust. Power on the system. Take multi-meter and verify LCD module is receiving power. If all fails, replace LCD screen.
3. Server is not receiving data
  - a. Solution: Open system and verify no wiring between magnetic card reader and RFID reader has come loose. If wiring has come loose, readjust accordingly. Press reset button on MCU and wait for green light. The system should reset and be ready for operation
4. Magnetic card reader is not working
  - a. Solution: Open system and press reset button on mcu. Run test module and swipe test card. If data transmission is insufficient disconnect USB of magnetic card reader from mcu board and connect to computer. Open NotePad. Swipe a magnetic card. If no data appears, magnetic card reader must be replaced. If data appears, reconnect to mcu board.
5. Lock does not open properly
  - a. Solution: Test the battery bank to ensure there is enough power to supply to lock. The condition of power is 12V in voltage and 2A in current values. Test the wire connecting between solenoids and other devices. Test the program to ensure there is no bug in the program. The program can be re-install if needed. Test the solenoid by connecting power supply directly.
6. Lock does not close properly:
  - a. Solution: Ensure the springs are in good condition, no rust or broken. Ensure the springs hang properly on the frame. Check the V-rod to ensure no bending.
7. DC-to-DC converter does not function



- a. Solution: Test the battery bank to ensure there is enough power to supply to the input of converter. Test the components to ensure no burn or loose connection.
  8. DC-to-DC converter smell burn and be hot
    - a. Solution: Install more heat sink on regulator.
  9. DC-to-AC converter does not function
    - a. Solution: Test the battery bank to ensure there is enough power to supply to the input of converter. Test the components to ensure no burn or loose connection.
- 

## **12. Administrative Content**

### **12.1. Legalities**

As previously stated, bike sharing programs have been increasing in size and popularity most recently over the past decade. With these programs comes the inherent risks and liabilities alongside having people use the system. It is important to safeguard the institution from any liabilities, damages or presumable death that may result in the unsafe use of a bicycle or the system. Complete separation from liability is not possible, however, limiting the liability the institution may face is plausible. The following is a list of suggestions that the institution may use in order to limit its liability:

- Waivers may be utilized and user must sign before using the system.
- Insurance may be purchased.
- Educating users on safe practices.
- Maintaining the system to safety standards.

Official legal counsel was not sought for this overview and is strongly advised.

### **12.2. Senior Design I Milestone**

Table XX.XX presents our milestone for Senior Design 1 semester. Originally we were ambitious on finishing quickly, but we hit many roadblocks. A major roadblock was the lack of success to acquire funding from various companies and potential sponsors. Due to the time delay in funding, that was altering our decision making in which components to not only research but choose. However, we were successful in acquiring funding via a GoFundMe.com in the later half of March.

<b>Senior Design 1</b>		
<b>Week Number</b>	<b>Week Start Date</b>	<b>Objectives</b>
3	1/25/2016	turn in initial document find funding
4	2/1/2016	schedule appointment with Dr. Richie start working on final document find funding
5	2/8/2016	Research IP Seeking Funding
6	2/22/2016	mid-term preparation (no research done)
7	2/29/2016	Research IP
8	3/7/2016	Research IP
9	3/14/2016	spring break
10	3/21/2016	Research IP
11	3/28/2016	Funding acquired
12	4/4/2016	Rough draft due (90 pages turned in)
13	4/11/2016	Paper Completion IP
14	4/18/2016	Paper Completion IP Finalize budget
15	4/25/2016	complete final document Finalize budget
16	5/2/2016	Spring Semester officially complete Begin testing
17	5/9/2016	Testing IP

Table 52 – Senior Design I Milestone

### 12.3. Senior Design II Milestone

Senior Design 2		
Week Number	Week Start Date	Objectives
1	5/16/2016	Testing/correcting errors Programming Schematic design
2	5/23/2016	Testing/correcting errors Programming Schematic design
3	5/30/2016	Testing PCB complete/Order PCB
4	6/6/2016	PCB shipping IP
5	6/13/2016	Implementation and Testing
6	6/20/2016	Implementation and Testing Building physical structure
7	6/27/2016	Implementation and Testing Building physical structure
8	7/4/2016	Begin creating presentation
9	7/11/2016	Presentation/Showcase material acquisition
10	7/18/2016	Presentation/website creation
11	7/25/2016	Presentation
12	8/1/2016	Showcase

Table 53 – Senior Design II Milestone

### 12.4. Budget

For this project, our initial estimation for the project is \$1,500 which covers all the material fees, shipping fees, PCB fees, and emergency fees. Since our project involves the big power system, we want to spend more on for most of our electrical components. Due to some financial constraints, we decide to find an alternative solution to work out for our plan. We decide to reconstruct our design so it can minimize our budget by at least \$500 less than our initial goal. Our method of doing so are: first) reusing any household medium that is no long needed, second) finding the best and most cost efficient place to order our electrical components, third) utilizing the school labs to avoid any equipment fees. As the result, our new budget goal is \$1000 which is \$500 cheaper than the old plan. This new budget covers most of the main components we need, included all the shipping cost. However, it leaves us little room for emergency case. Some of the biggest changes that we make are in choosing photovoltaic device, battery system, and structure of the bike rack.

Name	Quantity/Types	Price/unit	Status
Solar Panel	2x(100 watts offgrid solar panel)	\$245	confirmed
Charge Controller	Charge Controller (Included PCB)	\$35	research
Battery	4x(Duracell 6V 215Ah deep-cycle battery)	\$336	research
DC-DC inverters	3x(build)	\$70	research
DC-AC inverters	1	\$30	research
TI CC3200 SimpleLink	1; sample from TI	\$0	donated
TI CC3200 Launchpad	1	\$0	donated
Magnetic card reader	1/prime eligible	\$17.78	purchased
RFID reader	1/prime eligible	\$12.80	purchased
TI Stellaris Launchpad	1	\$13.38	In Transit
TI Stellaris LCD Module	1	\$35	In Transit
FTDI Board	(2) USB 2 I2C	\$9.95	In Transit
Phototransistor	1	\$5	research
camera	1	\$25	research
Microcontroller for the camera	1	\$40	research
LED strip	1	\$15	research
External hard drive	1	\$65	research
Motion Sensor	1	\$12	research
Bike Rack Structure			
Others	shipping cost, material cost	\$100	research
	Total	\$1,103.58	

Table 54 - Project Budget List Estimation

---

## 13. Appendixes

### 13.1. Appendix A - Permission Requests

**From:** Thai Orlando [<mailto:thaiorlando@gmail.com>]  
**Sent:** zondag 13 maart 2016 23:36  
**To:** Victronenergy sales  
**Subject:** Asking Permission

To Whom It May Concern

My name is The Pham, I am a senior electrical engineering student at University of Central Florida. My team and I work on a senior design project which involves Off-Grid Solar Power System. My role is to research about the PV power system which includes the Charge Controller, and Battery Storage System. As I have browsing the internet to read and learn more about the photovoltaic system, I happen to see the PDF file "White-paper-Which Solar charge controller, PWM or MPPT?". After reading through the material, I have learned and understood more about the charge controller as its physical properties. I am writing a document about my project, which is required to incorporate all the graph and data that related to the PV power system. I am writing this email to ask for permission to reuse the data graph of the Current Vs Voltage Graph from your article for my document to demonstrate the physical relationship between the MPPT and PWM Charge Controller. I guarantee that all the materials I use are for education purpose, not for sale or anything that violates the copyrights.

Sincerely,  
The Pham  
Undergraduate Student  
Department of Electrical and Computer Engineering  
University of Central Florida  
[407-506-4702](tel:407-506-4702)

Fwd: Asking Permission

Inbox x

 **Johannes Boonstra** <[jboonstra@victronenergy.com](mailto:jboonstra@victronenergy.com)>

to me ▾

Hello,

You have permission.

P.s

We would like to receive a copy of the final document please

Best regards  
Met vriendelijke groet  
**Johannes Boonstra**  
Mobile: [+31 651328860](tel:+31651328860)

cid:image001.png@01D0581E



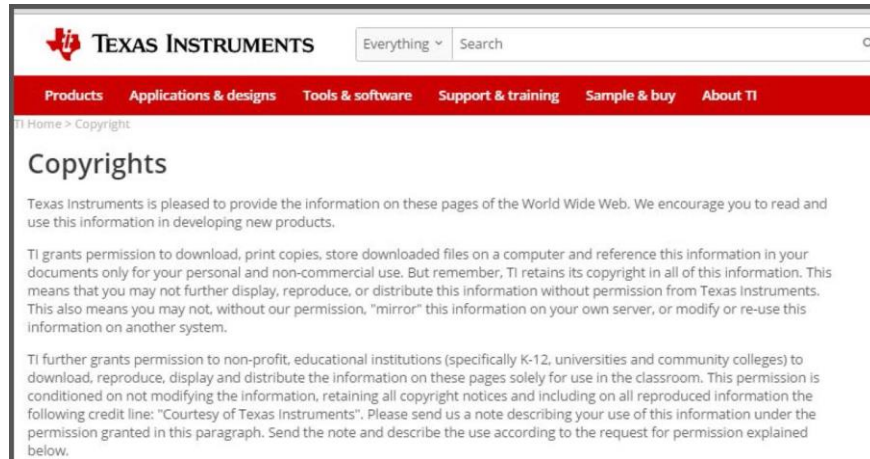

**TEXAS INSTRUMENTS** Everything Search

Products Applications & designs Tools & software Support & training Sample & buy About TI

TI Home > Copyright

## Copyrights

Texas Instruments is pleased to provide the information on these pages of the World Wide Web. We encourage you to read and use this information in developing new products.

TI grants permission to download, print copies, store downloaded files on a computer and reference this information in your documents only for your personal and non-commercial use. But remember, TI retains its copyright in all of this information. This means that you may not further display, reproduce, or distribute this information without permission from Texas Instruments. This also means you may not, without our permission, "mirror" this information on your own server, or modify or re-use this information on another system.

TI further grants permission to non-profit, educational institutions (specifically K-12, universities and community colleges) to download, reproduce, display and distribute the information on these pages solely for use in the classroom. This permission is conditioned on not modifying the information, retaining all copyright notices and including on all reproduced information the following credit line: "Courtesy of Texas Instruments". Please send us a note describing your use of this information under the permission granted in this paragraph. Send the note and describe the use according to the request for permission explained below.

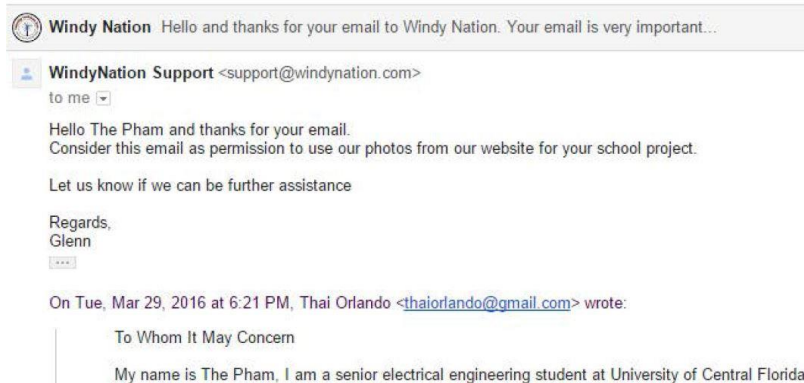

**Windy Nation** Hello and thanks for your email to Windy Nation. Your email is very important...

**WindyNation Support** <support@windynation.com>  
to me

Hello The Pham and thanks for your email.  
Consider this email as permission to use our photos from our website for your school project.

Let us know if we can be further assistance

Regards,  
Glenn

On Tue, Mar 29, 2016 at 6:21 PM, Thai Orlando <thaiorlando@gmail.com> wrote:

To Whom It May Concern

My name is The Pham, I am a senior electrical engineering student at University of Central Florida.

## 14. Works Cited

[1]“Bike-sharing Planning Guide”, Institute for Transportation & Development Policy, New York, New York

link: [https://www.itdp.org/wp-content/uploads/2014/07/ITDP\\_Bike\\_Share\\_Planning\\_Guide.pdf](https://www.itdp.org/wp-content/uploads/2014/07/ITDP_Bike_Share_Planning_Guide.pdf)

[2]“Bike-sharing: Models, Prevision, and History”, Paul DeMaio, MetroBike, LLC, Journal of Public Transportation, Vol. 12, No. 4, 2009

link: <http://bike.cofc.edu/bike-share-program/history%20of%20bike%20sharing.pdf>

[4]