

April 25, 2023

# **Self-Sustaining Hydroponic Greenhouse with Photovoltaic Power and Optical Sensing**



**University of Central Florida**

**Department of Electrical Engineering and Computer Science**

Dr. Lei Wei

**College of Optics and Photonics**

Dr. Aravinda Kar

**Group 5 - Spring 2023**

Kaleb Morgan

Computer Engineering

Connor DiMatteo

Optics and Photonics

George Kiriazes

Optics and Photonics

## Table of Contents

1.0 Executive Summary .....	1
2.0 Project Narrative .....	3
2.1 Problem Statement .....	3
2.2 Motivation.....	3
2.3 Function .....	3
2.4 Project Inspirations .....	3
2.5 Goals and Objectives .....	4
2.5.1 Goals .....	5
2.5.1.1 Core Goals .....	5
2.5.1.2 Advanced Goals .....	5
2.5.1.3 Stretch Goals.....	6
2.5.2 Objectives .....	6
2.5.2.1 Core Objectives.....	6
2.5.2.2 Advanced Objectives .....	6
2.5.2.3 Stretch Objectives .....	7
2.6 Engineering Requirement Specifications.....	7
2.6.1 Power .....	8
2.6.2 Microcontroller .....	8
2.6.3 Hydroponic System.....	8
2.6.4 Sensors .....	8
2.6.5 House of Quality .....	8
2.7 Block Diagrams .....	10
2.7.1 Overview .....	10
2.7.2 Photovoltaic System (Research) – George; Connor .....	10
2.7.3 Rainwater Collection System (Research) - George; Connor .....	11
2.7.4 Nutrient System (Research) - George; Connor; Kaleb .....	11
2.7.5 Hydroponic System (Research)-George; Connor; Kaleb .....	12
2.7.6 Control System (Research) - Kaleb .....	13
3.0 Research and Part Selection.....	14
3.1 Related Projects and Products.....	14
3.1.1 Walt Disney World’s “The Land” .....	14
3.1.2 Automated Home Hydroponics System.....	15
3.1.3 Pocket ‘Ponics.....	15
3.1.4 UV Water Analysis System .....	15
3.1.5 Solar Powered Water Filtration System.....	16
3.2 Optical & Photonic Considerations for Greenhouse System.....	16
3.2.1 Photovoltaic Panels.....	16
3.2.2 Ultraviolet Water Purification.....	18
3.2.3 Spectroscopy Water Analysis .....	19
3.2.3.1 Part Selection .....	22

3.2.4 Multispectral Sensor Leaf Nitrogen Reporter .....	23
3.2.5 Light Emitting Diodes.....	24
3.2.6 Liquid Level Detection .....	24
3.3 Relevant Technologies .....	26
3.3.1 Microcontroller .....	26
3.3.1.1 Comparisons .....	28
3.3.1.2 LP-MSP430FR2476 LaunchPad™ Development Kit .....	29
3.3.2 Wireless Data Communication .....	30
3.3.2.1 Wi-Fi.....	30
3.3.2.2 Bluetooth.....	31
3.3.3 Wi-Fi Module.....	32
3.3.3.1 Comparisons .....	32
3.3.4 EC/TDS Sensor .....	33
3.3.4.1 Comparisons .....	33
3.3.5 Liquid Level Sensor.....	34
3.3.5.1 Comparisons .....	34
3.3.6 UART to RS232 Converter.....	35
3.3.6.1 Comparisons .....	35
3.3.7 pH Sensor.....	35
3.3.7.1 Comparisons .....	36
3.3.8 Voltage Regulation .....	36
3.3.8.1 12V Regulator Comparisons.....	37
3.3.8.2 3.3V Regulator Comparisons.....	37
3.3.9 GPIO Pin Conservation .....	38
3.3.9.1 Multiplexer Comparisons .....	38
3.3.9.2 Decoder Comparisons.....	39
3.4 Water Purifiers .....	39
3.4.1 Sediment Filters .....	40
3.4.2 Reverse Osmosis .....	40
3.4.3 Distillation.....	41
3.4.4 Carbon Filters.....	41
3.4.4.1 Activated Carbon Blocks .....	41
3.4.4.2 Granular Activated Carbon (GAC).....	42
3.4.5 Filter Selection .....	43
3.4.5.1 Ultraviolet Light Plus Sediment & Carbon Well Water Filter Purifier System.....	43
3.4.5.2 Ultraviolet Reverse Osmosis Water Filtration System.....	44
3.4.5.3 Bluonics 4 Stage Purifier/Filter System.....	45
3.5 Liquid Pumps .....	46
3.5.1 Submersible Pump & Non-Submersible Pump.....	46
3.5.2 Peristaltic Liquid Pump.....	47
3.6 Hydroponic Techniques .....	47
3.6.1 Wick Hydroponic System .....	48
3.6.2 Drip Hydroponic System .....	48
3.6.3 Ebb and Flow .....	48
3.6.4 Deep Water Culture (DWC) .....	49

3.6.5	Aeroponics .....	49
3.6.6	Nutrient Film Technique (NFT).....	50
4.0	Related Standards and Design Constraints .....	53
4.1	Related Standards.....	53
4.1.1	Wi-Fi Standard.....	53
4.1.2	C Programming Language Standard .....	54
4.1.3	Water Quality Standards .....	54
4.1.4	Raman Spectroscopy Standards.....	56
4.1.5	Solar Power Standards .....	56
4.2	Design Constraints .....	56
4.2.1	Solar Power Constraints.....	56
4.2.2	Economic and Schedule Constraints.....	57
4.2.3	Social and Ethical Constraints .....	57
4.2.4	Health and Safety Constraints.....	58
4.2.5	Spectroscopy Constraints.....	59
4.2.6	Filtration Constraints .....	60
5.0	System Designs.....	61
5.1	NFT System .....	61
5.2	Rainwater Collection System.....	62
5.3	Nutrient and pH Deposition System .....	67
5.4	Photovoltaic System.....	69
5.5	Greenhouse Design and Layout .....	72
5.6	Control System.....	73
5.6.1	Hardware and Schematics.....	74
5.6.1.1	DC-DC Circuits .....	77
5.6.1.2	Power Switching Circuit.....	77
5.6.1.3	LP-MSP430FR2476.....	77
5.6.1.4	ESP-01S .....	78
5.6.1.5	RS-232 Circuit .....	79
5.6.1.6	Liquid Level Sensing Circuit.....	80
5.6.1.7	Headers .....	80
5.6.1.8	PCB.....	80
5.6.2	Software .....	81
5.6.2.1	Digital I/O .....	82
5.6.2.2	Timers .....	83
5.6.2.3	ADC .....	83
5.6.2.4	UART.....	84
5.6.2.5	Liquid Level Sensing .....	84
5.6.2.6	Power Switching Control.....	84
5.6.2.7	ESP-01S .....	85
5.6.3	Testing.....	85
5.6.3.1	DC-DC Supply.....	85
5.6.3.2	Liquid Level Sensing .....	85
5.6.3.3	User Device Communication Initial .....	86
5.6.3.4	User Device Communication Final.....	89
5.6.3.4	ADC .....	89

5.7 Optical System .....	90
5.7.1 Water Sampling System.....	90
5.7.2 Lens System Testing.....	91
6.0 Administrative Content.....	94
6.1 Final Budget with System Breakdown .....	94
6.2 Project Milestones.....	97
6.2.1 Senior Design 1.....	98
6.2.2 Senior Design 2.....	98
6.3 Sponsors.....	99
7.0 Conclusion .....	100
8.0 About Us.....	102
9.0 Work Cited.....	103

## List of Tables

Table 2.5.1 Goals and Objectives.....	4
Table 2.6.1 Engineering Requirement Specifications .....	7
Table 3.2.1 Silicon Technologies.....	17
Table 3.2.2 Raman Excitation Sources.....	21
Table 3.3.1 Microcontroller Comparisons.....	29
Table 3.3.2 Wi-Fi versus Bluetooth.....	31
Table 3.3.3 Wi-Fi Module Comparisons.....	33
Table 3.3.4 S-EC-01 versus SEN0244.....	34
Table 3.3.5 Liquid Level Sensor Comparison.....	35
Table 3.3.6 Drive/Receiver Comparison.....	35
Table 3.3.7 pH Sensor Comparison.....	36
Table 3.3.8 S-8580 vs. LM25118.....	37
Table 3.3.9 TPS622177 vs. TPS62901.....	38
Table 3.3.10 Comparison of multiplexers.....	39
Table 3.3.11 Comparison of decoders.....	39
Table 4.1.1 Wi-Fi Standards Comparison.....	54
Table 4.1.2 Hydroponic Plants EC and pH.....	55
Table 4.2.1 Effects of Current on Humans.....	59
Table 5.6.1 Truth Table for Power Switching Circuit.....	77
Table 5.6.2 LP-MSP430FR2476 Pins .....	78
Table 5.6.3 Function Selection for MSP430FR2476.....	83
Table 5.6.4 Test Cases.....	86
Table 5.6.5 List of Commands and Responses.....	88
Table 6.1.1 Final Budget.....	94-97
Table 6.2.1 Project Milestones for Senior Design 1.....	98
Table 6.2.2 Project Milestones for Senior Design 2.....	99

## Table of Figures

Figure 2.6.1 House of Quality.....	9
Figure 2.7.1 Hardware Block Diagram.....	10
Figure 2.7.2 Photovoltaic System.....	11
Figure 2.7.3 Rainwater Collection System.....	11
Figure 2.7.4 Nutrient System.....	12
Figure 2.7.5 Hydroponic System.....	12
Figure 2.7.6 Control System.....	13
Figure 3.2.1 Photonic Integration.....	16
Figure 3.2.2 Energy Diagram.....	20
Figure 3.2.3 Raman Spectroscopy Setup.....	22
Figure 3.2.4 Raman Spectrometer.....	22
Figure 3.2.5 Leaf Nitrogen Status.....	23
Figure 3.2.6 Optimal Wavelengths for Photosynthesis.....	24
Figure 3.2.7 Optical Water Level Sensor.....	25
Figure 3.3.1 8-Bit SPI.....	27
Figure 3.3.2 I2C Method .....	27
Figure 3.3.3 Sampling during ADC.....	28
Figure 3.3.4 Wireless LAN Channels.....	30
Figure 3.4.1 Activated Carbon Block Filter.....	42
Figure 3.4.2 Bluonics 4-Stage UV Purification System.....	44
Figure 3.4.3 Express Water 6-Stage Water Purification System.....	45
Figure 3.4.4 Bluonics Under Sink Water Filtration System.....	46
Figure 3.5.1 Peristaltic Pump .....	47
Figure 3.6.1 Ebb and Flow.....	49
Figure 3.6.2 Nutrient Film Technique.....	50
Figure 5.1.1 NFT System Design.....	62
Figure 5.2.1 Rainwater System Design.....	65
Figure 5.2.2 System Specific Reservoir Design.....	66
Figure 5.3.1 Nutrient/pH Deposition System.....	68
Figure 5.4.1 Photovoltaic System.....	71
Figure 5.5.1 Greenhouse Layout .....	73
Figure 5.6.1 Schematic diagram of our project .....	74
Figure 5.6.2 Schematic diagram of our project .....	75
Figure 5.6.3 MAX3222 .....	79
Figure 5.6.4 Final PCB.....	81
Figure 5.6.5 Software Block Diagram.....	82
Figure 5.6.6 Formula for Resulting Digital Value .....	84
Figure 5.6.7 Liquid Level Sensing Testing Environment .....	86

Figure 5.6.8 User Device Communication Testing Environment .....	87
Figure 5.6.9 Example of User Interface on User's Device.....	88
Figure 5.6.10 Final User Interface.....	89
Figure 5.6.11 ADC Formula for 12-Bit Conversion.....	89
Figure 5.7.1 Optical Setup.....	90
Figure 5.7.2 Final Optical Setup for Testing.....	92
Figure 5.7.3 Spectrum of Water Sample.....	93



## **1.0 Executive Summary**

Throughout the world, food insecurity has become a growing issue as global inflation has increased, causing massive increases in the price of food and energy. The problem has been further exacerbated by incessant supply chain issues that make accessing the monetarily inaccessible food even more difficult by making the imports physically inaccessible. Despite the size and wealth of the United States, this issue is clearly present domestically in both rural and urban areas. In recognition of the growing concerns over food insecurity in local communities, we have sought to combat these concerns by creating a scalable solution that can be implemented around cities, communities, neighborhoods, and households. This solution is presented in the form of a self-sustainable community garden that can be used to generate food for individuals facing food shortages.

Community gardens are already a widely understood solution for combatting food insecurity within cities, but there is a plethora of problems that render community gardens inefficient and inoperable. Some of these problems include the inability to acquire the space necessary to build a thriving garden, a lack of available volunteers or paid personnel to maintain the garden, the scarcity of resources required to build, maintain, and expand the garden, and a lack of knowledge on the best gardening practices for specific plants. We believe that some of these issues can be solved through clever innovation, while other issues will require a strong emphasis on the community aspect of the garden. Thus, fundraising is an essential component of this project that requires members of the community to buy into the vision of community gardens as a source of security.

Having identified these inhibitors to community gardens, we have resolved to design a system that requires minimal knowledge about plants or gardening while needing little to no daily maintenance to thrive independently off a grid. In this project, we design four separate systems that will be integrated together to create a single self-sustaining community garden. These four systems are a hydroponic system, rainwater collection system, photovoltaic system, and a central greenhouse system. We gravitated towards hydroponics immediately due to their ability to have high yields with a very efficient use of resources. This makes hydroponics more ideal for community gardens compared to traditional gardening methods because it removes the need to find a suitable landscape on which to place the garden while also allowing us to make efficient use of vertical space to increase the overall growth volume in a compact area. One of the primary goals of this project is to ensure the garden is operable without the need to connect to a power grid or water line. Therefore, we will construct a rainwater collection system that will capture and purify water for use in the hydroponic system while powering the entire greenhouse using a photovoltaic system. The greenhouse structure will be used to house elements from each system in an insulated and controllable environment that mitigates the effects of outside factors such as animals, insects, and weather.

Our hydroponic system is modeled after the nutrient film technique of hydroponic horticulture. Nutrient film technique (NFT) posits nutrient solution into water which is pumped to the top of an incline growth tray to slowly trickle over the roots of a plant to allow it to receive the nutrients directly. NFT does not require the use of any soils and enables the most efficient access to essential nutrients for the plants. This method therefore

saves time and money while increasing yields by removing the need to maintain healthy soil using fertilizers or pesticides. In this design, we pump the nutrient solution to the highest of three levels to flow down the growth trays, depositing nutrients to each plant as it continues through the system. The system is designed to grow a single species of plant with the maximum possible yield. To increase the total yield of the system as well as increase the rate of growth, we included ultraviolet LED lights in the greenhouse design to provide for possible twenty-four growth. The light cycle is optimized to the plants as some plants do not thrive under constant growth conditions.

The rainwater collection system is designed with a series of filtering mechanisms to have the cleanest possible water being deposited to the plants. Hydroponic gardens benefit the most from the use of distilled water for their nutrient solutions. In this case, we are not able to distill the rainwater in a quick and cost-effective way, so we sought to reduce the number of contaminants in the water as much as possible through a hybrid filtration system. The water is first channeled from the roof of the greenhouse structure through a mesh filter to block large debris into a central water reservoir. The central reservoir then analyzes the water for any contaminants such as microorganisms and triggers a UV-C light to kill any microbes. The water then passes through a carbon filter to filter out the remaining contaminants before pumping to a separate reservoir that is designated for a specific hydroponic system. These sub-reservoirs function as the recycling point from the plant system to conserve nutrients. The pH and nutrient concentration analysis occurs in the sub-reservoirs with the pH balancing and nutrient depositions occurring there as well.

The photovoltaic system is oriented to face the east, and it provides DC power to the rest of the systems. It serves as the most important element to ensuring the greenhouse can function without a connection to a power grid, and therefore, the optimization of its power generation is a core goal for the project's overall functionality.

The greenhouse itself is used to house multiple hydroponic systems, the system's battery, and many of the electrical components associated with the project. Anyone using or monitoring the garden would be able to do so by connecting to the local area network about the greenhouse to review all the data, cycles, and statuses of the various systems. Through backend coding, we can automate almost every process necessary for the greenhouse to function. The only processes that are not automated in this design are harvesting crops, repairing broken or malfunctioning parts, and refilling nutrients, pH-balancers, and water.

Our greenhouse is an excellent proof of concept that access to food is a manageable problem that can be solved in a sustainable way. This project has the potential to generate far reaching impacts around the country and globe. Having resolved some of the problems inhibiting the development of community gardens, the construction of these self-sufficient greenhouses has the potential to combat food insecurity on a massive scale in a manner that is environmentally conscious, economically feasible, socially acceptable, and politically attainable. People across the globe can recognize the need to find viable agricultural space as commercial and residential space slowly eats away at our farmland. Thus, the addition of small-scale gardening initiatives throughout localities can serve as an effective opportunity to ensure everyone has equal access to healthy, affordable food.

## **2.0 Project Narrative**

We outline the general project overview in this section to provide an in-depth description of why we are seeking to accomplish this project and what it is intended to do.

### **2.1 Problem Statement**

Over the last forty years, municipalities across the state have undergone rapid development because of the rapid influx of residents that has more than doubled the population of Florida. The steady growth of the state has resulted in unchecked urban sprawl, sudden gentrification, and diminished access to fresh organic foods. As these problems become more prevalent, city residents are faced with rising prices that make living a happy, healthy lifestyle unaffordable for an average family. While concerns grow, localities are falling behind on implementing sustainable agricultural initiatives, such as community gardens, to combat these issues. Failures to implement community gardens as a potential solution can be attributed to three main concerns: lack of knowledge, resources, and people.

### **2.2 Motivation**

The motivation behind this project is derived directly from the problem statement. We are seeking to overcome the three main concerns hindering community gardens to combat the larger issues of food insecurity, sustainable agriculture, and diminished quality of life. Having identified the aforementioned issues in the nearby city of Oviedo, we intend to develop a self-sufficient hydroponic greenhouse requiring minimal human contributions with affordable fixed costs and low variable costs. We will make this a smart, self-monitoring system so that we can effectively eliminate the potential lack of knowledge, resources, or people that may inhibit the implementation of these initiatives.

### **2.3 Function**

Our greenhouse will be an entirely self-contained system with many sub-systems involved in ensuring it has all the resources necessary to continue operation. The primary function of the greenhouse is to house three independent hydroponic systems, each growing a different crop using the nutrient film technique for growth. The second function of the greenhouse is to collect and divert rainwater into a purification reservoir to be distributed to each of the plant systems with the proper nutrient concentrations specified for each plant. The third function of the greenhouse is to utilize photovoltaic cells to capture solar energy and provide power for the systems. Upon completion, this self-sufficient greenhouse will function as a source of affordable organic produce for the community as well as an educational tool for residents on the benefits of sustainable agriculture.

### **2.4 Project Inspirations**

We have identified several former projects that we plan to expand upon to enhance their features, efficiency, and size. The two projects we are taking inspiration from for our hydroponic systems are the “[Automated Home Hydroponics System](#)” from Group E in Fall 2020 and the “[Pocket ‘Ponics](#)” project in Fall 2019. For the rainwater collection system and photovoltaic system, we are taking inspiration from the “[UV Water Analysis System](#)” from Group 5 in Fall 2020 and the “[Solar Powered Water Filtration System](#)” from Group 24 in Fall 2019. Each of these projects provide essential knowledge necessary to

developing the numerous sub-systems we intend to include in our greenhouse. For a detailed analysis of the projects, review “6.1 Related Projects and Products”.

## 2.5 Goals and Objectives

There are numerous goals and objectives associated with building this project. Many of these goals are essential to the functionality of the project while others add improvements to the sub-systems to increase system efficiency, yields, and viability. The table below lists each of the goals organized by system.

Hydroponic System	
Goal	Objective 1.0
Grow many plants of the same species according to a specific plant profile	Program plant profiles
	Automate the water and nutrient pumps according to profile
	Build a cascading housing
	Monitor the pH-balance, nutrient concentration, and cycles
Construction of each system is affordable	Materials should be individually affordable and accessible
	Materials should be easy to work with
Create a compact system	System should utilize vertical space in compact horizontal space
Allow multiple species per system	Pump separate nutrient solutions into each level of the NFT system to grow one species per level
Rainwater Collection System	
Goal	Objective 2.0
Channel rain into system	Utilize gutters along roof to channel water through screen lid
Filter contaminants	Use a dual water filter (carbon filter and UV purification)
Automatically pump water and nutrients into hydroponic systems	Pump water into the hydroponic systems as needed
	Sensors trigger pH balancing when water pH breaks range
	Sensors trigger nutrient pumps to maintain NPK ratio of water
Use spectroscopy to analyze water quality	Integrate a spectrophotometer to detect contaminants
	Implement a UV purifier inside the reservoir
Photovoltaic System	
Goal	Objective 3.0
Generate power for the system	Optimize solar collection of panels outside the greenhouse
	Include power channels to all electronic devices
Develop tilt mechanism	Track sun position to tilt panel for most direct sunlight
Store excess power	Channel surplus power into a battery
Greenhouse	
Goal	Objective 4.0
Ensure connectivity between all internal systems for automation	Develop a LAN network for monitoring and system control
	Internal sensors connect to microcontroller to create mesh
	Scale independent system sizes within housing
Climate Control Housing	Include A/C unit and humidifier/dehumidifier in greenhouse
	Core
	Advanced
	Stretch

**Table 2.5.1** Goals and Objectives

### **2.5.1 Goals**

There are three goal levels that we have used to list the goals of our project for each subsystem: core, advanced, and stretch. The core goals act as the driving force behind the project, giving us both direction on how to design the project and targets to ensure the project is solving the problems discussed in section 2.1. The advanced goals serve as opportunities to further innovate a system that is, otherwise, already well developed. Many groups, companies, and innovators have developed their own versions of hydroponic gardens, but the advanced goals would serve as system enhancements beyond the minimum specifications for the greenhouse to achieve our goals. The stretch goals would push us into a maximally efficient system that would have the highest possibly production with backup measures in place to ensure the system can thrive without ideal conditions.

#### **2.5.1.1 Core Goals**

Starting with our core goals, we recognized immediately that we would need to group our goals by system in addition to their level. This would allow us to create a list of priorities as well as an order to follow when designing, constructing, and testing our system. The highest priority system is the hydroponic system as this will be the method by which we manage the problem of food insecurity. The core goals associated with the hydroponic system are to create a compact system that can fit in the greenhouse, construct the system out of easy to use, affordable materials, and grow a large quantity of a single species of plant according to a specific encoded plant profile. The second priority system was the rainwater collection system as this would be the method by which the water is acquired for the hydroponics in addition to completing the nutrient depositions for the specific plant profile. There are three core goals for the rainwater collection system: catch and channel water from the roof of the greenhouse into a reservoir, automatically pump water and nutrients into the hydroponic system, and filter any contaminants out of the water. Third, we have the photovoltaic system. The core goal of the photovoltaic system is to generate power for the system to be stored in a battery. Finally, the greenhouse is the last priority for the overall functionality of the system. Though the project is intended to be housed in a greenhouse, it is not actually imperative for the project concept to work. The core goals of the greenhouse are to be able to house multiple hydroponic systems and ensure connectivity of all internal systems for automation. The “greenhouse” in this case is referring to the project as whole without giving specific regard to the physical structure of the greenhouse.

#### **2.5.1.2 Advanced Goals**

Each system does not itself have an advanced goal; however, there are still several advanced goals to note. When determining the best way to measure nutrients and contaminants in the water, we felt that the use of spectroscopy might prove to be the best selection. This is because we would be able to determine the exact concentrations of nutrients and contaminants in the water to employ our filtering and nutrient deposition methods in the most efficient way possible. However, this is a very difficult and costly system to implement, so it has been classified as advanced under our rainwater collection system. The second advanced goal is to add a tilt mechanism to the solar panels to increase their power output. We recognize that this is not essential to our project and is not imperative for the size greenhouse we intend to use, but in larger systems, this would

enhance the power generation efficiency. The last advanced goal we have considered is to add climate control inside the greenhouse structure to regulate the temperature and humidity of the housing to the average optimal values of the hydroponic systems. This would add an extra element of control over the growth environment of the systems to continue to drive our efficiency as high as possible.

### **2.5.1.3 Stretch Goals**

Finally, we have included two stretch goals that could be implemented to allow the system to function well even when faced with poor conditions. The first stretch goal is to make each hydroponic system suitable for more than a single species of plant. This would involve each hydroponic system having separate nutrient depositions to each level of their vertical system. The second stretch goal is to channel surplus power generation to a secondary battery. This would allow the system to function in the absence of any power generation for a finite time while the solar panels are inoperable or underperforming.

### **2.5.2 Objectives**

To achieve each of these goals we have generated specific objectives associated with each of them. These objectives will allow us to develop a list of engineering requirement specifications to further guide the design of the project.

#### **2.5.2.1 Core Objectives**

The core objectives are directly related to the core goals of the project and our list of priorities. Beginning with the hydroponic system, the objective associated with creating a compact system is to utilize vertical space and minimize the use of horizontal space for each system. To construct an affordable system with easy assembly, each component should itself be affordable and readily accessible in addition to being easily manipulated without the use of industrial machining tools. Growing large quantities of a single plant species will be achievable by programming specific plant profiles, automating the water and nutrient pumps according to those profiles, building a cascading structure, and monitoring the pH-balance, nutrient concentration, and growth cycles of the plant. For the rainwater collection system, we will build gutter system to channel the rainwater. Additionally, we will use the sensors from the hydroponic system to trigger the pumping mechanisms for pH-balancing and nutrient depositions according to the water pumping cycle of the plant. The system will utilize a dual filtering mechanism to kill any microbes and passively remove particulates from the water before entering the plant system. The power generation from the photovoltaic system includes objectives to optimize the solar collection of the panels outside the greenhouse and include power channels for the electronic devices. Finally, to house multiple hydroponic systems, the greenhouse will have to make efficient use of internal space, and it must include a module that connects to each sensor to create a mesh of sensors to automate the system.

#### **2.5.2.2 Advanced Objectives**

Should we utilize a spectroscopy to analyze the water quality, we identified two objectives that would need to be completed to integrate it. First, we would need to employ the use of a spectrophotometer, and second, we would need to ensure it was measuring in the visible to near-infrared spectrum for optimal analysis. This analysis would be used to trigger the

ultraviolet light to kill any microorganisms detected in the water. The second advanced goal for the project was to add a tilt mechanism to the photovoltaics. The primary objective would therefore be to track the position of the sun to ensure the solar cells are tilting at an angle that will allow for the most direct sunlight possible. Finally, the use of a humidifier, dehumidifier, or air conditioning system would allow greater control over the growth environment. Therefore, our objective would be to monitor the humidity levels and temperature within the greenhouse. The second objective would be to trigger the systems to regulate the temperature and humidity to acceptable average values according to the plants that are growing in the hydroponic systems.

### 2.5.2.3 Stretch Objectives

To make each hydroponic system suitable for more than one plant, our objective would be to deposit a specific nutrient solution to each level in the system according to that level's plant profile. This creates the additional objective to channel water from the reservoir through a series of valves to deposit into the proper level. The second goal to channel surplus power to another battery would be accomplished through the objective to route power from the first battery at its maximum capacity into the second battery for charging.

## 2.6 Engineering Requirement Specifications

There are numerous specifications that must be met to complete the objectives we have set out to achieve our project goals. We outline some of the engineering requirement specifications here.

Hydroponic System	
Objective	Engineering Requirement Specification
1.1	The system shall be equipped with three profiles for each independent system
1.2	The plant profiles shall trigger the pumps according to a programmed growth schedule
1.3	The growth trays shall utilize gravity to channel the water to the plants and reservoir
1.4	Each system shall employ sensors to measure nutrients and pH
1.5	Total cost of materials per system shall not exceed \$300
1.6	Systems shall utilize lightweight plastics or metals less than a half inch of thickness
1.7	Systems shall not exceed maximum dimensions of 1.5 ft wide x 5 ft long x 6 feet tall
Rainwater Collection System	
Objective	Engineering Requirement Specification
2.1	The spectrophotometer shall utilize Raman spectroscopy for water quality analysis
2.2	Ultraviolet light shall be within the UV-C range of 200-280 nm to kill 99% of microbes
2.3	Water pump shall have a head height of two meters and a variable gpm pump rate
2.4	The pH balance of the water shall be maintained within the range of 6 to 7
2.5	The NPK ratio shall be maintained according to requirements of each plant profile
Photovoltaic System	
Objective	Engineering Requirement Specification
3.1	Panels shall produce at least an average of 100 watts of power per day
3.2	Power shall be converted from DC to AC to ensure compatibility with each device
3.3	Power generated beyond the primary battery's capacity shall be channeled to a secondary
Greenhouse	
Objective	Engineering Requirement Specification
4.1	LAN network shall enable data collection and transmission to MCU for processing
4.2	Microcontroller shall be Wi-Fi enabled and have a minimum of 128 KB of RAM
4.3	Structure shall be able to house three independent hydroponic systems

**Table 2.6.1** Specifications for the hydroponic system, rainwater collection system, photovoltaic system, and the greenhouse broken up into objectives

### **2.6.1 Power**

- Clean Energy: The greenhouse should be able to sustain itself using only energy it collects from the connected solar panels.
- Energy Storage: There must be a constant, reliable source of energy for the pumps and sensors. Surplus energy should be stored efficiently for later use (ex. night).
- Voltage Regulation: PCB should regulate the incoming and outgoing voltage according to the needs of individual systems and sensors.

### **2.6.2 Microcontroller**

- Low Power: The microcontroller should be able to function at low power to reduce electric usage.
- Data Collection: Must be able to quickly collect and store sensor data.
- Communication: Microcontroller must be compatible with chosen local network connection.

### **2.6.3 Hydroponic System**

- Materials: Beds should be made of affordable, durable PVC material.
- Size: The system (bed, water, and nutrients) should be large enough to hold the various plants and vegetables but also compact enough to optimize space.

### **2.6.4 Sensors**

- Low Power: The sensor playground should process and interpret data while consuming minimal electricity.
- Accuracy: Sensors should report accurate data to the microcontroller with high accuracy and minimal error.
- Maintenance: The sensor mesh will operate through extended periods of time without the need for support.
- Size: The sensors must be of a scale small enough to be housed within the sub-systems.
- Compatibility: Each sensor must be compatible with the microcontroller to ensure they are properly integrated within the mesh network.

### **2.6.5 House of Quality**

The House of Quality diagram depicted below is used to demonstrate how our engineering requirements and our market requirements interact with each other. This will allow us to understand the impact and importance our innovations have on the project relative to each other.



Positive Correlation	↑
Strong Positive Correlation	↑↑
Negative Correlation	↓
Strong Negative Correlation	↓↓
Positive Polarity	+
Negative Polarity	-

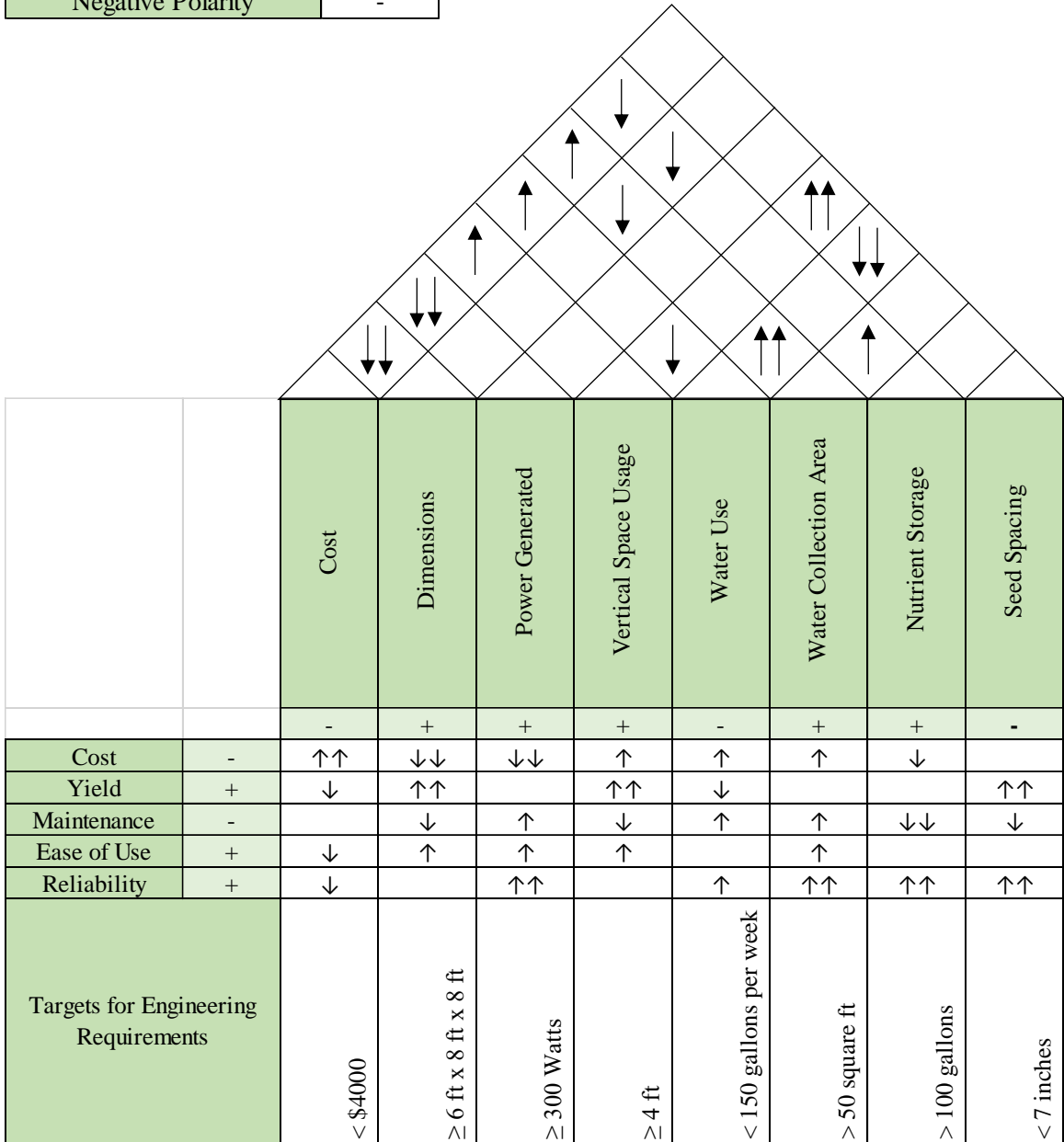


Figure 2.6.1 House of Quality

## 2.7 Block Diagrams

The block diagrams depicted below provide some guidance on the system inclusions, designers, and integrations from system to system. Each block diagram is intended to provide greater detail from a top-down perspective into how we intend to construct each system without discussing in specific detail the exact methods, science, or products we will use to accomplish each of these systems.

### 2.7.1 Overview

1. Greenhouse: Houses the plants and other systems.
2. Hydroponic System: Maintains supply of nutrients to plants.
3. Control System: Monitors all the sensors and provides and determines the actions taken. Provides users access to the greenhouse data and settings via an interface.
4. Rainwater Collection System: Provides purified water to the plants in the greenhouse.
5. Nutrient System: Provides specific nutrients to the plants in the greenhouse.
6. Photovoltaic System: Provides electricity to the greenhouse.

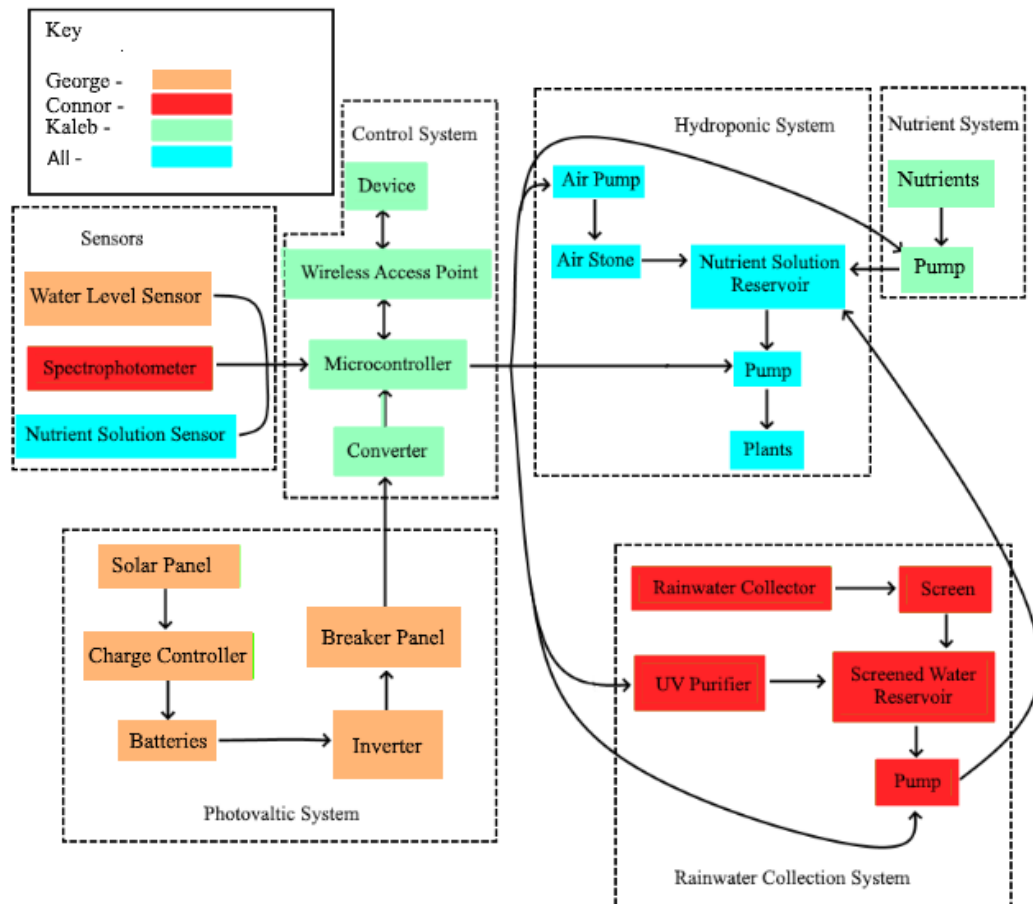
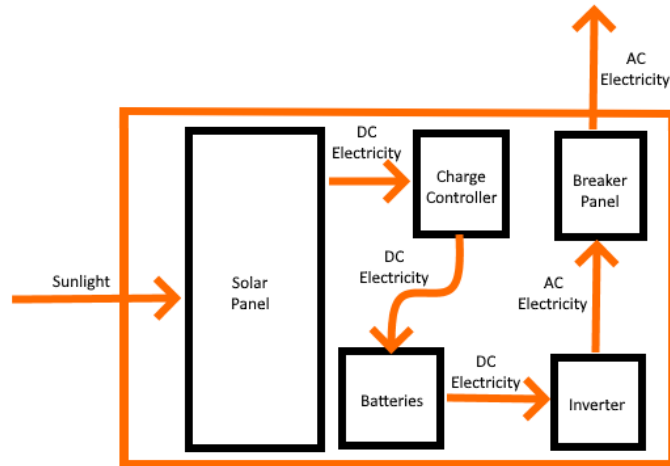


Figure 2.7.1 Hardware Block Diagram

### 2.7.2 Photovoltaic System (Research) – George; Connor

1. Solar Panel: Converts sunlight into DC electricity.
2. Charge Controller: Limits the rate at which electric current is added to or drawn from batteries.

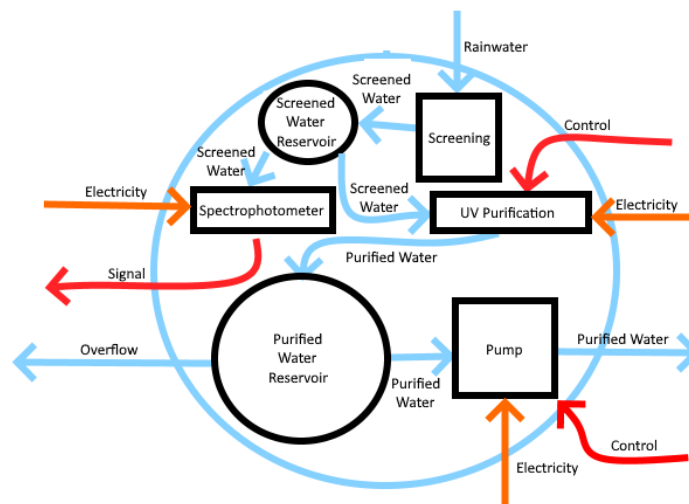
3. Batteries: Store the electricity.
4. Inverter: Converts DC electricity to AC electricity.
5. Breaker Panel: Switches to control the flow of electricity.



**Figure 2.7.2** Photovoltaic System

### 2.7.3 Rainwater Collection System (Research) - George; Connor

1. Screening: Remove objects from the water.
2. Initial Reservoir: Stores the rainwater after it has been screened.
3. Spectrophotometer: Monitors the level of water contaminants.
4. UV Purification: Purifies the water using UV light.
5. Purified Water Reservoir: Stores purified water.
6. Pump: Moves the purified water from the reservoir to the greenhouse.

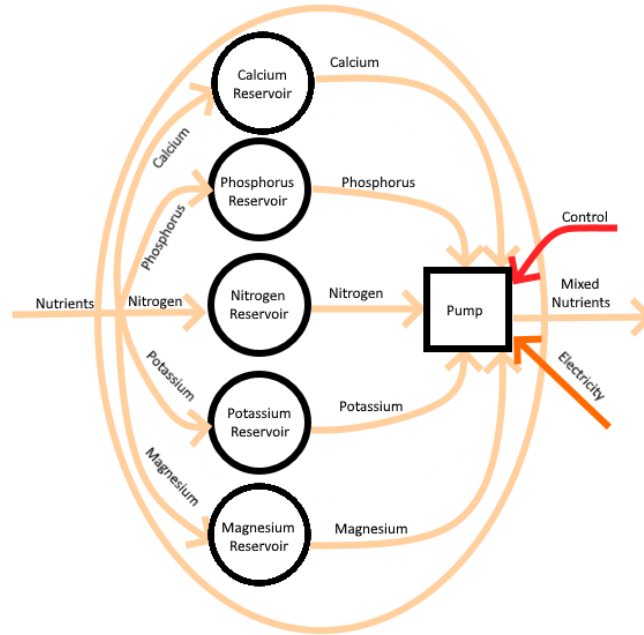


**Figure 2.7.3** Rainwater Collection System

### 2.7.4 Nutrient System (Research) - George; Connor; Kaleb

1. Phosphorus Reservoir: Stores phosphorus.
2. Nitrogen Reservoir: Stores nitrogen.
3. Potassium Reservoir: Stores potassium.
4. Calcium Reservoir: Stores calcium.

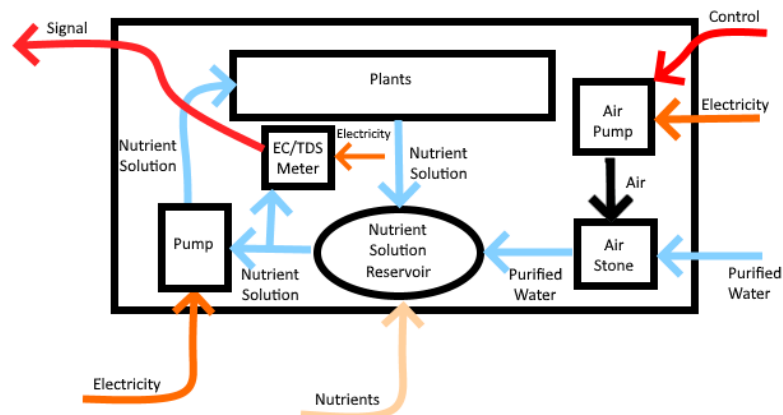
5. Magnesium Reservoir: Stores magnesium.
6. Pump: Moves the nutrients to the greenhouse



**Figure 2.7.4** Nutrient System

### 2.7.5 Hydroponic System (Research)-George; Connor; Kaleb

1. Air Pump: Moves air to the air stone.
2. Air Stone: Diffuses air into the water.
3. Nutrient Solution Reservoir: Stores the nutrient solution for plants.
4. EC or TDS Meter/Spectrophotometer: Measure the concentrations of the nutrient solution reservoir
5. Pump: Moves the nutrient solution to the plants.
6. Plants: Grow and make food.



**Figure 2.7.5** Hydroponic System

### 2.7.6 Control System (Research) - Kaleb

1. Controller: Takes in signals from sensors and tells the system what to do. Sends and receives data from Local Area Network.
2. Local Area Network: Facilitates communication between devices within a small range.
3. Device: Examine data from the greenhouse and make changes to the settings.

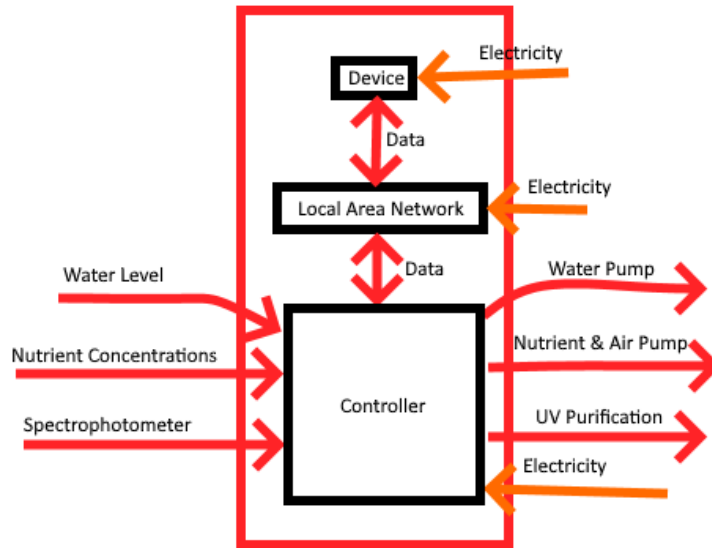


Figure 2.7.6 Control System

### **3.0 Research and Part Selection**

This is expected to be a very large and robust project with all our goals in mind. As a result, we have had to complete copious amounts of research into similar projects and products in addition to the research needed for the components we will be including in the project. This section details that research as well as our justification for the parts we have selected for use.

#### **3.1 Related Projects and Products**

Hydroponic gardens have increased in prevalence in recent years as consumers and researchers have begun to recognize the potential benefits of this method economically, environmentally, and socially. Consumers around the world have started to gravitate toward hydroponically grown produce in support of the sustainable initiatives it catalyzes. As a result, numerous products and projects have been created based on the various hydroponic methods for plant growth. Additionally, global focus on climate change has spurred research and applications of small-scale sustainable systems like photovoltaic use for backyard sheds and rainwater collection for lawn care. As a result, we were able to review a plethora of pre-existing product examples for integrating these systems with our hydroponic growth technique. Most importantly, greenhouses are used across the globe to grow every kind of crop from microgreens to avocados, and there are innumerable examples of greenhouses that utilize many of the same systems we seek to employ here. Therefore, the following sections will focus on reviewing several of the projects and products that have inspired our project development.

##### **3.1.1 Walt Disney World's "The Land"**

Perhaps the largest influence on the initial project concept came from Walt Disney World's most sustainable ride, "Living with the Land". The ride, of course, is just to give visitors an inside look at a much larger operation. Epcot houses four greenhouses on property, totaling over 2.5 million square feet of active gardening space. [33] Within the greenhouses, Disney's Imagineers and horticulture experts employ a multitude of farming practices including multiple forms of hydroponics. Some of their growth techniques include nutrient film technique, aeroponics, aquaponics, vertical gardening, and ebb and flow. This does not include their applications of aquaculture, traditional farming, and hybrid techniques for producing the highest yields and most efficient systems possible. The greenhouses are designed to provide an optimal growth environment to maximize crop yields by controlling the temperatures, monitoring for pests and diseases, and directly depositing nutrients to plants. [34] Their innovative techniques have allowed the greenhouses to produce record breaking plants such as a single tomato plant that could produce over 13000 fruits, amounting to over 1150 pounds of tomatoes. [34] Obviously, Disney has large amounts of space and an exorbitantly large budget to fund research and development, but we were inspired to take notes from their practices to implement them on a smaller scale. Specifically, this application gave us insight on essential practices for high yield, sustainable gardening including application of hydroponics, climate-controlled environments, alternate growth techniques, and plant monitoring. Each of these are areas of interest for us as we continue to design our systems for municipal applications.

### **3.1.2 Automated Home Hydroponics System**

Our group spent copious amounts of time reviewing previous hydroponic projects completed by Senior Design groups. While many of them had applicable technologies and methods for our purposes, we felt that the Automated Home Hydroponics System was worth noting when reviewing possible practices. The project was designed to allow for the use of indoor space to grow plants. To do so, the group designed a small housing structure out of wood and PVC that contained all the internal systems including the water reservoir, nutrient reservoir, and pH balancers. However, the primary inclusion from their project of note was the use of an LED light array to engage plant growth indoors. Since our project is seeking to grow plants at the fastest possible rate with the highest possible yield, we have considered implementing LED arrays to accommodate 24-hour plant growth. Further, we would like to display the relevant data the systems collect on an LCD display for easy monitoring. We have, therefore, reviewed this projects considerations and design while determining the method in which we will design our own system.

### **3.1.3 Pocket ‘Ponics**

The second most pertinent project utilizing hydroponics was Pocket ‘Ponics in 2019. This was another home application of indoor water-based gardening that sought to solve the problem of food desserts in an affordable way. Our group identified similar goals and motivations from this project that drew our attention including the desire to combat food insecurity through a compact system that requires no technical knowledge to operate. This system was designed to be roughly the same size as a bookshelf that was capable of growing tomatoes, green beans, turnips, and spinach in a layered vertical style garden. Of course, the garden would be automated, but we were specifically interested in the application of LED arrays on each level of the garden in addition to display of information via an integrated phone application. In recognition of the fact that individuals may not always be willing or able to drive to the greenhouse to monitor it, we have considered the possibility of sending the data to a website or mobile application. This would be particularly difficult to integrate in our case being that this is a greenhouse without any connections to formal infrastructure. We have instead taken inspiration from this project to create a local area network within the structure to possibly forgo the use of an LCD display.

### **3.1.4 UV Water Analysis System**

Because our system will not be attached to any city water or power lines, we are including a rainwater collection system as part of the overall unit. As a result of this inclusion, we must design a water analyzing and purifying system to ensure the water entering our plant systems is free of contamination, such as pests, particulates, and microorganisms. Thus, we sought to review previous projects that analyzed water and cleaned it for any application. This was one of the two projects we felt were applicable for our applications. The designers of this project created an in-line water analysis system using Raman spectroscopy that also utilized a hybrid purification system to clean the water. Furthermore, this system was optimized for use in areas with limited access to resources by powering the system with solar panels. For these reasons, we determined that this would be a key project for us to review when designing our rainwater collection system in addition to optimizing our photovoltaic powering system. Specifically, we have considered achieving our advanced goal of utilizing spectroscopy for water analysis by implementing a scaled version of their

system for regular use in our three sub-reservoirs that feed the hydroponic systems. Additionally, we will likely build a hybrid purification system similar to them with some modifications such as front-line channel screening to reduce the accrument of large debris in the water reservoirs.

### 3.1.5 Solar Powered Water Filtration System

Between the two water filtration systems we considered, this project presented us with more insight on how the data collection process from the system might look. We specifically are consulting the information from this project to understand what information was deemed relevant by the designers whose sole focus was on producing drinkable water. As a result, we were able to understand more about how we might be able to process data from the rainwater collection system for review in a mobile application or on an LCD display. We previously mentioned our two considerations for how an individual can monitor our greenhouse system, and the Solar Powered Water Filtration System group demonstrated very well how both an LCD display and a mobile application could be used to present the data from the water quality analysis. We will spend additional time consulting this project as we further develop our LAN network within the structure.

### 3.2 Optical & Photonic Considerations for Greenhouse System

An important emphasis of our project is the photonic aspects of the self-sufficient plant growing process. The major photonic pieces for the greenhouse are the photovoltaic panels, multispectral sensor leaf nitrogen reporter sensor, spectroscopy water analysis process, and the ultraviolet water purification process. Connor and George will do these optical aspects. The integration into the control system will be focused on by Kaleb.

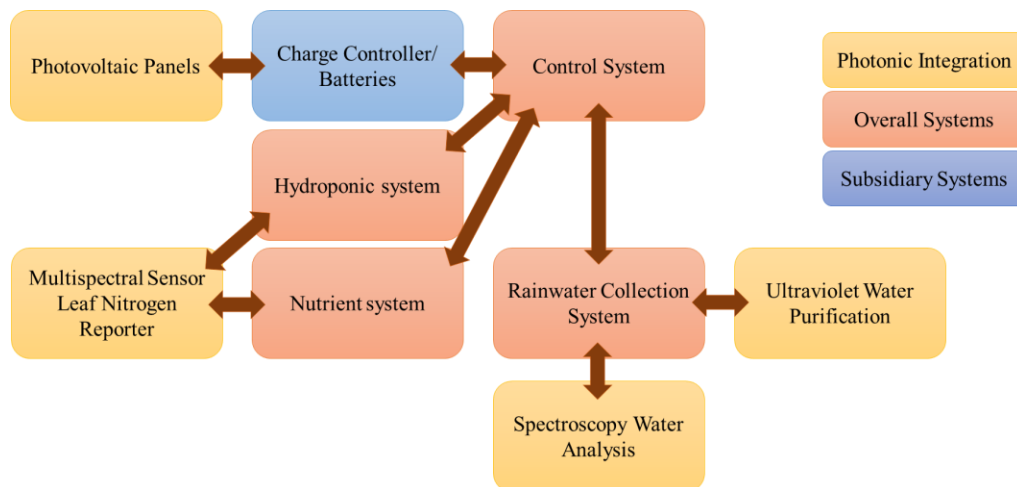


Figure 3.2.1 Photonic integration into overall greenhouse system

#### 3.2.1 Photovoltaic Panels

For the use of a self-sufficient system, a solar array that would be able to supply power to the greenhouse environment 24 hours a day would be ideal. Though possible to have a solar system provide enough power to run 24 hours a day, it would come as no surprise that such a system would require a much larger solar array which in turn would also require



a much higher budget being designated to the energy collection system. To compromise on this specification a lower operation time of 8 hours a day was set for the full system to always have the required power needed. Smaller systems would be operational for longer while larger ones are limited in operation time to preserve the system. To figure out what photovoltaic device would be ideal for us, a deeper look is required into what is available.

Recently photovoltaic units have been subject to massive growth in the solar panel industry. This is a result in the rising demand for solar due to lower costs and federal tax credits aiding for lots of consumers, who in result, decide to integrate solar into their daily lives. With an independent system containing only solar panels and batteries you can expect between 12 and 24 volts to be achieved allowing for great off the grid uses.

When looking at the variety of solar energy options, there are different types of photovoltaic cells for different applications. Even though better options exist for solar energy, price point is one of the main factors when choosing which solar option to choose from. The main types of solar cell technology that are used are made up of polycrystalline silicon cells, thin-film solar cells, and monocrystalline silicon cells. Thin-film solar cell technologies are still being developed so this option would be less considered in our selection process.

Solar Cell Type	Efficiency Rate	Advantages	Disadvantages
Monocrystalline Solar Panels (Mono-Si)	~20%	High efficiency rate; optimised for commercial use; high life-time value	Expensive
Polycrystalline Solar Panels (p-Si)	~15%	Lower price	Sensitive to high temperatures; lower lifespan & slightly less space efficiency
Thin-Film: Amorphous Silicon Solar Panels (A-Si)	~7-10%	Relatively low costs; easy to produce & flexible	shorter warranties & lifespan

**Table 3.2.1** Different silicon technologies comparing the advantages and disadvantages of monocrystalline, polycrystalline, and thin-film solar panels. [13]

Monocrystalline silicon cells were the first breakthrough for solar technology. To create the wafers for the solar panel a silicon crystal is placed in molten silicon. This is then extracted from the molten silicon. The resulting silicon structure is formed into a wafer that will be used for a solar cell. The Monocrystalline silicon cell structure is one of the most efficient forms for solar technology because of the high purity silicon in the final silicon

wafers.[10] This structure results in a long lifetime for the solar cell, high efficiency, high output, and thermal resilience. All these factors allow for an efficiency rate of over 20%. However, these cells usually are more expensive to produce resulting in a large cost for consumers. Polycrystalline silicon structures came shortly after the monocrystalline silicon structures. The polycrystalline cells start similarly to the monocrystalline with a silicon crystal. The crystal is dropped into molten silicon but not removed like in a monocrystalline cell. This is left to cool which results in rigid crystal structures within the cells. This process is much faster and cheaper than that of a monocrystalline silicon cell. These quicker and cheaper processes result in a lower lifespan and a max efficiency of only 15%.[11] Polycrystalline silicon cells are a likely consideration for future design development due to its price point being within our budget for the overall greenhouse system.

When working with photovoltaic panels placement is a very important consideration to consider take into consideration to be able to optimize the amount of energy the solar panel is to collect. Angle and direction are the two most major concern in this regard, both being significant contributors on achieving maximum solar power collection. When dealing with a stagnant solar collection system it is typical to fix solar panels on an unshaded surface that faces true south with a tilt between 30 and 45 degrees. Having a stagnant solar collection system is a great choice to collect solar for structures such as houses which may already have the infrastructure like roofs to mount solar panels to. However, having a stationary solar panel can only collect light for part of a day as it is unable to face towards the sun.

To get the most out of a solar panel rotating solar panels are able to track the sun's location and get the most out of a single solar panel however there are many disadvantages to doing so. When considering pricing having a rotating solar panel greatly increases the price of a solar panel for not much return. To be able to operate the tilt mechanism itself would use energy to do so. Another consideration to make is often rotating solar panels are more prone to failure than its stationary counterparts. Introducing moving mechanical parts always introduces more points of failure into a system. When using a tilting solar panel, you must be willing and able to provide enough room for the solar system to have complete movement freedom causing issues with spacing and shading.

### **3.2.2 Ultraviolet Water Purification**

Ultraviolet light is attractive for filtering water due to its great germicidal properties. Since we desire a system with full control of most aspects of what the plants in the system receive, a purification and filtering step is wanted to help remove any unwanted aspects from the water that may reach the plants. Plants can be affected by many different impurities found in rainwater including chemicals, heavy metals, and other impurities that could affect the efficiency of plant growth. By filtering rainwater to remove most chemicals and heavy metals and by using ultraviolet to remove any other microorganisms, we can take almost complete control over the nutrients and water that the plant will receive. Ultraviolet-C is the wavelength most used for germicidal properties which consists of the range between 100 nm and 280 nm. In a on the grid system, you could easily go about avoiding microorganisms and heavy metals by using distilled water. Since our goal is to have an off grid self-sufficient system, we must be able to produce as close to distilled water as we can to be able to give the plants the best chance possible at success. By using purified water, plants can grow faster and stronger than just using rain or tap water.

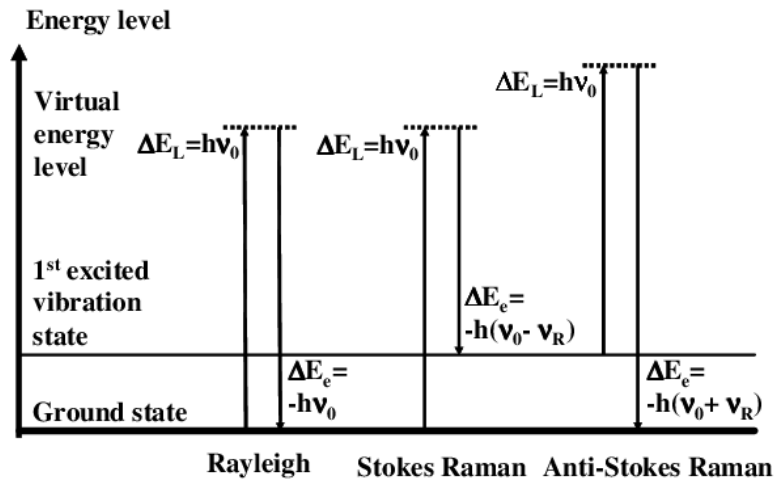
Ultraviolet light is attractive for filtering water due to its great germicidal properties. Since we desired a system with full control of most aspects of what the plants in the system receive, a purification and filtering step was used to help remove any unwanted aspects from the water that may reach the plants. Plants can be affected by many different impurities found in rainwater including chemicals, heavy metals, and other impurities that could alter the efficiency of plant growth. By filtering rainwater to remove most chemicals and heavy metals and by using ultraviolet to remove any other microorganisms, we can take almost complete control over the nutrients and water that the plant receives. Ultraviolet-C is the wavelength most used for germicidal properties which consists of the range between 100 nm and 280 nm. After our carbon-based filters, we used a stainless-steel cylinder with quarter inch tubing input and outputs for water to run through. A quartz tube was placed inside the housing to allow UV wavelengths to pass through into the water without making direct contact with our electronics. Inside the tube our UV-C bulb was placed attached to an AC 110V outlet that was powered by our 12v DC to 110V AC converter.

### **3.2.3 Spectroscopy Water Analysis**

Infrared is often used when trying to examine the structure of molecules in a sample. Infrared would cause issues if tried to be used with water analysis because water would absorb too much light for this type of spectroscopy to be efficient. Another form of spectroscopy that is sometimes used in similar applications is fluorescence spectroscopy. This type of spectroscopy relies on the excitation of electrons that make matter inside of water fluoresce. This method relies on dyeing the water which would need added additional chemicals into the system which would act counterproductive to our goal of purifying the water. In addition, fluorescence spectroscopy only can be used to detect fluorescent organic matter which does not include everything that we would be looking for in the water to insure purity.

Raman spectroscopy however allows for a specific wavelength to be used to analyze a sample with the wavelength being depended on the excitation source. When using Raman spectroscopy water also scatters these wavelengths the least making it a prime candidate for investigating organic compounds found in water.

There are two techniques used in Raman spectroscopy, being Stokes and anti-Stokes Raman spectroscopy. When looking at Stokes Raman spectroscopy photons from the excitation source collide with molecules which result in some of the energy from the photons transferring to the molecule. This loss in expected energy can be measured which results in seeing a wavelength shift, known as a Stokes shift. Anti-Stokes Raman spectroscopy on the other hand uses the photons from the excitation source and has them absorb energy from colliding with molecules. This gain of energy results in the wavelength shift in this case.



**Figure 3.2.2** “Energy diagram for Rayleigh, Stokes Raman, and anti-Stokes Raman scattering.” [52]

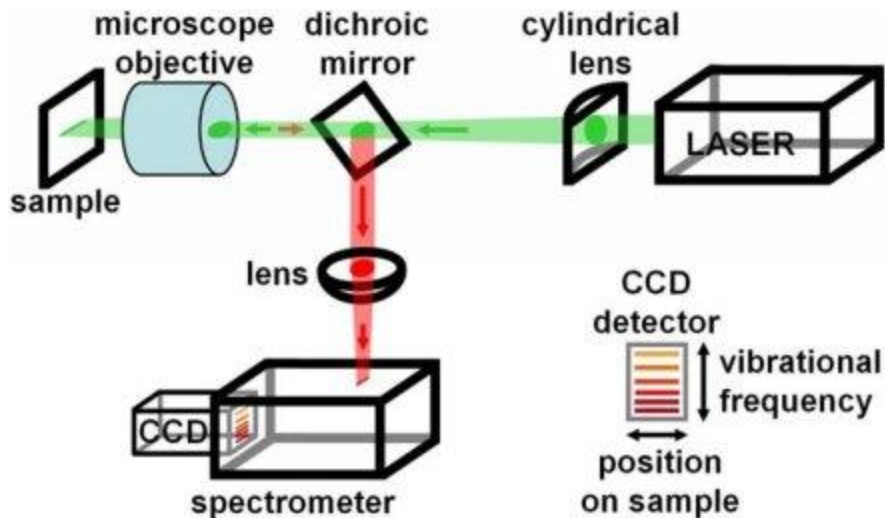
The energy levels for both the Anti-Stokes and the Stokes Raman scattering show that Anti-Stokes occurs at a higher vibration state. This results in the Stokes being much stronger than that of the Anti-Stokes.

Many different excitation sources can be used when performing Raman spectroscopy. Among them are visible light, ultraviolet light, and near infrared light. Each of these different common excitation sources for Raman spectroscopy have their benefits for different applications.

<b>Excitation Source</b>	<b>Laser Wavelengths</b>	<b>Applications</b>
<b>Near infrared light source</b>	<ul style="list-style-type: none"> <li>• Solid state Nd-YAG laser (1064 nm)</li> <li>• Diode Laser:(785, 830 nm)</li> </ul>	<ul style="list-style-type: none"> <li>• Biological samples</li> <li>• Polymers</li> <li>• General purpose</li> </ul>
<b>Visible light source</b>	<ul style="list-style-type: none"> <li>• Ion laser: He-Ne (633 nm), He-Cd (442 nm), Ar+ (488 nm &amp; 514 nm)</li> <li>• Solid state laser: Nd-YAG (532 nm)</li> </ul>	<ul style="list-style-type: none"> <li>• Organic components</li> <li>• Archeology &amp; forensics</li> <li>• Semiconductor minerals</li> <li>• General Purpose</li> </ul>
<b>Ultraviolet light source</b>	<ul style="list-style-type: none"> <li>• Ion laser: He-Cd (325 nm), Ar+ (244 nm &amp; 257 nm)</li> <li>• Solid state laser pumped dye laser: Ti-Sapphire</li> </ul>	<ul style="list-style-type: none"> <li>• DNA protein</li> <li>• Chromophores</li> <li>• Wide bandgap semiconductors</li> </ul>

**Table 3.2.2** Commercial Excitation sources used for Raman Spectroscopy and applications.[53]

Some common Raman spectroscopy used excitation sources are documented above. Some of the different excitation sources share some similar uses like that of the visible and ultraviolet excitation sources both being able to be used for semiconductor analysis. Among our excitation source options most notably is the near infrared source.



**Figure 3.2.3** Depiction of a normal Raman spectroscopy setup [54]

There is further consideration to make with use the of a near infrared excitation source Raman spectroscopy system. The technique used is also under consideration when looking at the different routes to use for the analysis of water; Normal Raman, Surface Enhanced Raman, and Fourier Transform Raman are all options for techniques that can be pursued. When looking at the Fourier Transform Raman you have to take into consideration that it requires the use of interferometers to work, making it a complex and less commercially available form of Raman spectroscopy. Surface Enhanced Raman spectroscopy is used often due to its efficiency and low concentration detection making it a great choice however it is a very complicated technique. Because of the restraints of both the Surface Enhanced Raman spectroscopy and Surface Enhanced Raman spectroscopy normal Raman spectroscopy is the best option for our required application.

### 3.2.3.1 Part Selection

Since some parts will be borrowed and not purchased due to spectrometers very high price point some options and choices were limited due to what was given to us to use. For the use of water analysis through a spectrometer. A previous senior design group from 2020 did a spectroscopy-based project on the analysis of water for UV purification to use as drinking water. This groups who worked on the “UV Water Analysis System” used a Raman spectrometer and the necessary emitter source to go along with the spectrometer.



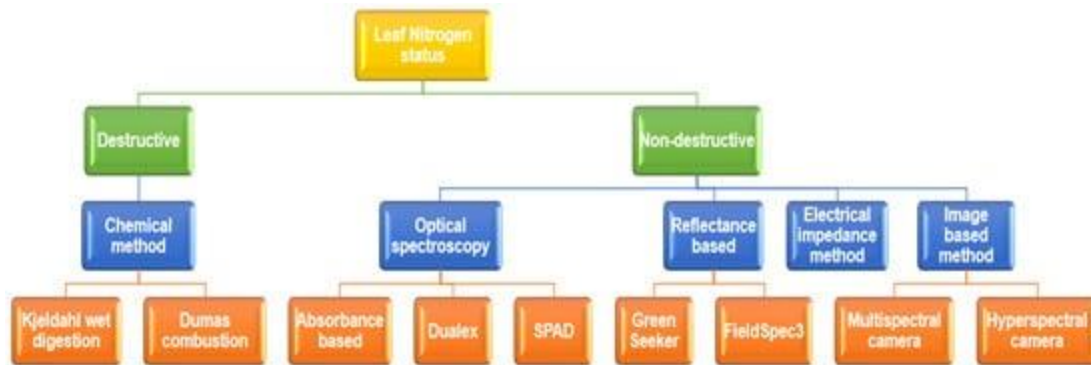
**Figure 3.2.4** Ocean insights Raman spectrometer.

We received a test unit of the QEPro that Ocean Insights created from leftovers of the previous ground. This unit connects through USB C and has a SMA fiber connection on the front. This unit will provide exactly what we want since we only need basic Raman spectroscopy measurements since unlike the previous group who used the unit to insure water was safe for human consumption we are just using the water for the plants.

To be able to use the Raman spectrometer we also needed a suitable laser module emitter for the job. Luckily with the borrowed spectrometer we also received the proper laser emitter to go along with it. This unit produces high-power spectrum stabilized 785 nm light which is perfect to go along with our spectrometer.

### 3.2.4 Multispectral Sensor Leaf Nitrogen Reporter

One consideration that we researched was using a multispectral sensor to be able to read and report on the level of nitrogen in a leaf. Knowing what is going into the hydroponic system is a great way to make sure that you are providing everything the plant needs in the form of nutrients; however, it's important to be able to know the actual nutrient status of the plant. Using a plants leaf nitrogen level can be a critical indicator which will tell us a lot about the nutrient information and thus the overall plants health. Many different forms of nitrogen are sensitive to the near-infrared and visible wavelength regions. There are many different methods to collect this information however the most practical is a non-invasive visible and near-infrared sensor to measure. Using the reflectance of around 550nm wavelength you can deduce many different nitrogen treatments for a plant.[12]

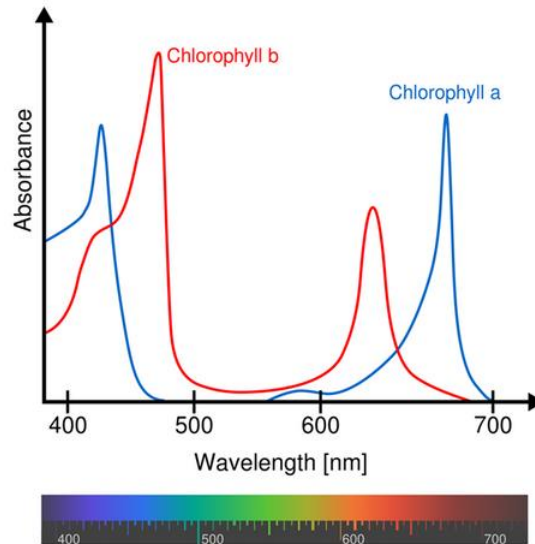


**Figure 3.2.5** “Destructive and non-destructive methods used for estimating leaf nitrogen status.”[12]

As seen in the figure above there are many different methods of optical imagery to determine the nitrogen status. Most of the less intrusive methods consist of a system to measure the reflectance or absorbance of the coloration of a leaf. This information is critical to represent the chlorophyll found in a plant. Using this indirect indication of the photosynthetic processes you can determine the plants overall health and vitality. Most of the options available to consumers to measure this information are expensive and hard to integrate into an overall mesh sensor network. However, options exist to build this crucial plant monitoring system at a low price point with high efficiency that is also capable of being directly integrated into an overall controlled and monitored network.

### 3.2.5 Light Emitting Diodes

When considering using LEDs to optimize plant growth it is crucial to understand which spectrum of light would be best to use to get the best yield out of a crop. Many different considerations go into choosing an optimal wavelength for growing crops including speed of growth, size of leaf growth and the size of the actual fruit or vegetable being produced as well. All these factors are affected by the light being exposed to the system. Seeing how our system is to be build outdoors inside of a greenhouse the idea of using LEDs is to increase plant growth past what you would normally see with a natural day cycle of growth.



**Figure 3.2.6** Optimal wavelengths for absorption for the use of plant photosynthesis. [42]

Blue photons (400-500 nm) have been shown to reduce plant height and leaf expansion in many different plant species. This is since most of the absorption of blue photons is done by inactive pigments. Blue photons are shown to be about 20% less effective for plant photosynthesis than that of normal red LEDs.[41] Green photons (500-600nm) are normally thought to be a non-contributor to photosynthesis due to lots of green light being reflected off most plants. However, it is shown that they can be up to 90% as photosynthetically efficient as a red LED and they penetrate deeper into a plant's canopies. Green light is also important for plants mostly to improve human perception of plant color however that is less important for our uses. Red photons (600-700 nm) are absorbed well into leaves and ideal for plant photosynthesis. To get the fastest rate of photosynthesis using LEDs, a combination of a high, red-based LEDs followed by some blue and then green photons produces the best results for plant growth. Since we are exposing the plant to natural sunlight as well as LEDs our focus for increasing plant growth will be by providing light in the 600-700 nm range of red photons to increase the overall photosynthesis within plants.

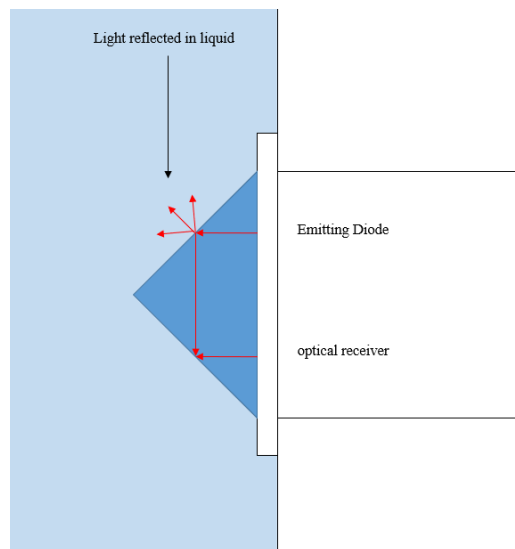
### 3.2.6 Liquid Level Detection

Liquid level detection plays a critical role in many different technological and commercial systems. There are many ways and methods that can be used to be able to detect the level of a volume, among them are mechanical, acoustic, ultra-sonic, capacitive, inductive, and



optical.[51] Choosing the correct leveling method depends on understanding the basic principles enabling correct selection for the application at hand. Many level sensor solutions are great for some applications while being a bad choice for others. For example, if you were in need to level something that is in a solid form like dust then using ultrasonic and mechanical methods would be an appropriate choice for the job.

Optical methods can be a good and appropriate choice of level sensing because of its simplicity and ease of adaptability to many forms of medium. In a classical optoelectronic level detection system light from a LED is transmitted towards a photodetector. The photodetector can detect the light coming from the LED allowing for the system to detect when something is at level due to the LED's light being cut off from reaching to the phototransistor. This is great for opaque liquids and dusts however when dealing with transparent liquids like water some limitations of optical properties must be accounted for.



**Figure 3.2.7** Concept behind a standard FS-IR1901D used for optical fluid level sensing.

When dealing with transparent liquids, novel level detection methods can be implemented into the system to detect when a liquid passes a designated point. Using a phototransistor, a LED and a small prism, water level can be properly sensed unlike in the previous scenario. A FS-IR1901D uses this concept to be able to detect the level of a volume of liquid. Near-infrared light is emitted from a diode which is reflected by a prism to the photosensitive receiver. When the lens of the photoelectric switch is immersed inside of a liquid, light isn't reflected to the optical receiver but is refracted into the liquid leaving little to no light to be sensed by the receiver. This break in the chain between the LED and the photosensitive receiver can detect when water passes a designated level.

A similar sensor can be used in our application to safely monitor water levels in the different reservoirs contained in the system. The most critical points of interest for these sensors would be in the main water collecting reservoirs as well as in the secondary nutrient solution reservoirs. These parts are the main concern to be able to know how much water is available in each container to properly dispense and mix the water and nutrients to the hydroponic systems. Another major application in our system is its use in the nutrient and

pH balancing storage allowing for the user to be properly notified when the system requires a refill.

### **3.3 Relevant Technologies**

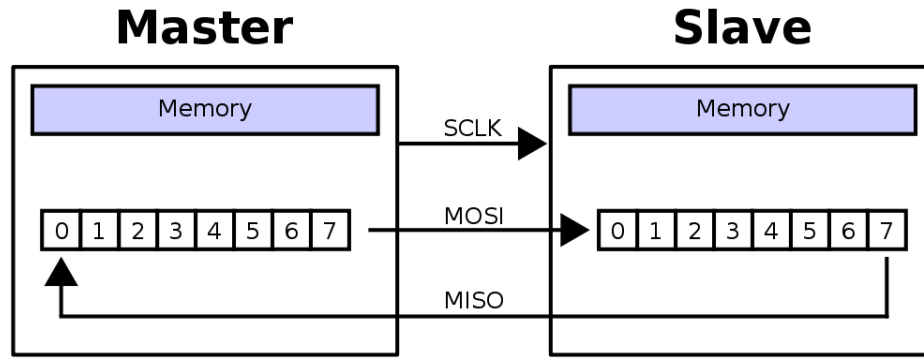
This section discusses the different technologies that will be used. A further understanding of the individual components that make up the system is important for understanding the system as a whole.

#### **3.3.1 Microcontroller**

Microcontrollers lie at the center of embedded applications and serve to automate specified tasks. Their ability to collect data from the outside world makes them a prime candidate for internet of things devices. Microcontrollers consist of memory, programmable I/O peripherals, and one or more processors. Memory included in these components is Non-volatile memory (Flash, FRAM, EEPROM) and volatile memory (RAM, SRAM). There are many different peripherals implemented by different microcontrollers but for the needs of our project we will take a look at UART, SPI, I2C and ADC.

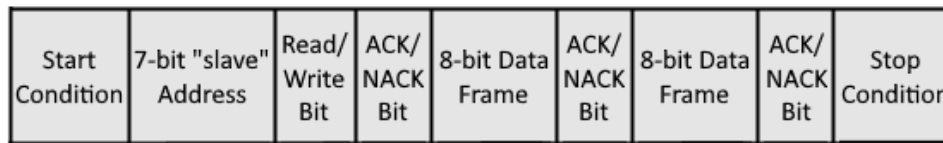
Universal asynchronous receiver-transmitter (UART) “is a computer hardware device for asynchronous serial communication in which the data format and transmission speeds are configurable.” [45] To exchange information utilizing UART communication requires only two wires; one from the transfer pin of the first device to the receive pin of the second device, and the other from the receive pin of the first device to the second device. Data is sent and received between devices bit by bit at a predefined speed referred to as the baud rate. For proper UART communication the same baud rate must be used for both devices. Framing is used on the data to determine the start and stop bits of the data stream.

Serial Peripheral Interface (SPI) is a synchronous serial communication interface commonly used for short-distance communication between two or more devices. SPI follows the master/slave model of communication control and only requires 4 wires operating in simplex mode to implement a SPI bus. The master provides a common serial clock (SCLK) and master out slave in (MOSI) line, as well as a chip select (CS or SS) line for each “slave” device in the independent slave configuration. The master receives a common master in slave out (MISO) line. With proper connections in place data communication can begin. The “master” must first configure the clock to a frequency supported by the slave device. Using the chip select line a “slave” is selected. During each clock cycle the “master” sends one bit to the “slave” over the MOSI line at which point the slave reads it. During this time the “slave” device sends one bit to the “master” over the MISO line and the “master” reads it. Regardless of whether you wish to transfer bi-directional or one-directional data this same method is used. Usual implementations involve a shift register in each of the devices with the MSB of each register being transmitted over their respective lines (MOSI, MISO) then shifted on the first clock edge. On the next clock edge, the devices sample their lines and assign the bit to the LSB of their register. Below is one example for this implementation.



**Figure 3.3.1** 8-bit SPI bus transfer using two devices with shift registers. [46]

Inter-Integrated Circuit (I2C) “is a synchronous, multi-controller/multi-target (master/slave), packet switched, single-ended, serial communication bus.” [47] Similarly to UART, I2C requires only two lines to perform data transmission. These two lines are denoted serial data (SDA) and serial clock (SCL). The SCL is provided by the “master” at a frequency supported by the “slave”. As I2C is synchronous, a single bit is sampled and output during each clock cycle over the SDA line. Sending a message over I2C is a bit different than the previously discussed communication methods. An I2C message is broken down into several bits and frames as in the example figure below.

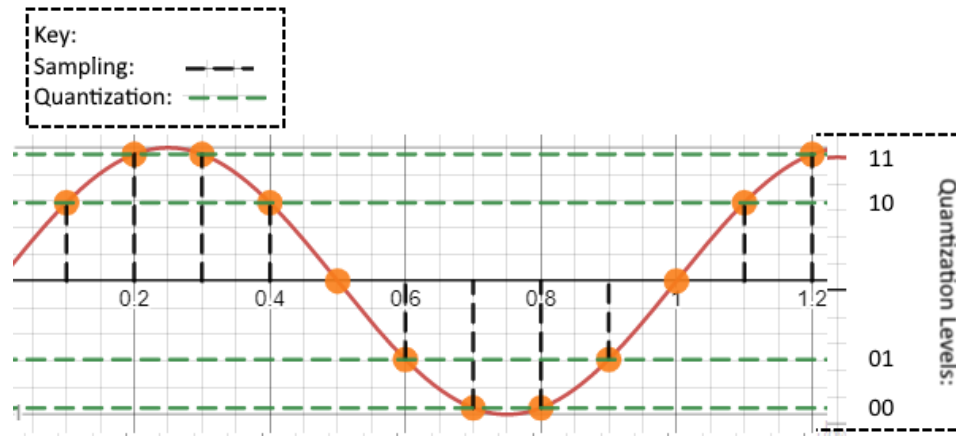


**Figure 3.3.2** Example of I2C message using 7-bit addressing.

The start condition occurs when SCL is held high and SDA transitions from high to low. This signal sets to “master” in transmit mode at the start of communication. After the initial signal SCL is held low and the “master” provides the address of the “slave” that it wishes to communicate with, followed by one bit indicating whether the “master” wishes to read from or write to the target “slave”. If the target exists on the bus, then it will respond with an acknowledgement bit (ACK). If the target does not exist on the bus it will respond with a negative acknowledgement bit (NACK). With the target acknowledged and the mode realized data is either sent to the “master” in read mode or written to the “slave” in write mode, one byte at a time. These bytes are followed by either an ACK or NACK bit sent by the “master” in read mode or the “slave” in write mode. This process is repeated until all the data is sent, and a stop condition is set. This stop condition occurs when the SCL is held high, and the SDA transitions from low to high. This marks the end of the transmission.

An analog-to-digital converter (ADC) takes an analog signal such as a voltage, samples the signal, quantifies the signal, and provides a digital response. Sampling a signal involves taking measurements at specific time steps of the analog signal. The higher the frequency of the samples the more closely the sampled signal will resemble the initial analog signal. Quantization involves taking a continuous set of values and turning them into a discrete set of levels. These levels are determined by the number of bits provided by the ADC. Many

ADCs provide 10-bit or 12-bit resolution giving us 1024 or 4096 levels respectively. Most of the time these converters are implemented as integrated circuits. An example of how an analog signal is quantified and sampled is given below. The sampling rate for this example can be seen as .2s or 5 Hz, while there are 4 quantization levels requiring a 2-bit ADC.



**Figure 3.3.3** Example sampling and quantization during ADC.

### 3.3.1.1 Comparisons

When selecting a microcontroller for our design we had much to take into consideration. The microcontroller serves as the brain of our design, so it is imperative that it functions properly. Our design incorporates several sensors as well as a wireless communication module, providing input to the microcontroller. The microcontroller needs to provide output to pumps, the purifier and the wireless communication module. When comparing microcontrollers, we must look at their ability to implement all the necessary tasks and stay within our design specifications and constraints. The characteristics that determined our selection are broken down.

- **Power Consumption:** Running off solar power requires us to limit our power usage throughout our design. We must look for an option that has low power consumption to ease the strain on our system.
- **Peripherals:** The Wi-Fi module and some sensors will use UART to communicate with the microcontroller. Other communication protocols needed to communicate with other sensors are I2C and SPI. Analog-to-digital converters are also necessary as some of our sensors will be providing analog input signals. Having an excess of GPIO pins would also help to implement the water level sensor and pumps as well as any new devices.
- **Memory:** We intend to store and access data of many sizes so it would be beneficial to use a microcontroller with ample memory. Having a small amount of random-access-memory especially may require extra steps when programming which would be better off avoided.
- **Cost:** With a limited budget we must conserve funds wherever we can. Luckily, there are many low-cost microcontroller options to choose from.
- **Debugging and Programming:** Being able to debug and reprogram the microcontroller quickly will increase the speed of development. Understanding how to program the microcontroller will also help.

	<u>MSP430G2553</u>	<u>MSP430FR2476</u>	<u>MSP430FR6989</u>	<u>ATMEGA32A</u>
Feature	Microcontroller	Microcontroller	Microcontroller	Microcontroller
Non-volatile memory	16 KB	64 KB	128 KB	32 KB
Random access memory	0.5 KB	8 KB	2 KB	2 KB
GPIO pins	24	43	83	32
UART	1	2	2	1
I2C	1	2	2	1
SPI	2	4	4	2
Current Consumption	.5uA - 230uA	.6uA - 135uA	0.35uA - 100uA	1uA - 600uA
Cost	\$0.95	\$3.45	\$4.17	\$5.08

**Table 3.3.1** Microcontroller comparison between the MSP430G2553, MSP430FR2476, MSP430FR6989, and the ATMEGA32A

The microcontroller selected for this design was the MSP430FR2476. The main reasons that this microcontroller was selected were due to its ample communication channels and GPIO pins, abundant volatile and non-volatile memory, and low price and power consumption. Texas Instruments also provides a development kit, the LP-MSP430FR2476 based on the MSP430FR2476. Using this development kit will slightly limit our hardware capabilities but the benefit comes with the great simplification of PCB design as well as quick and easy programming and debugging.

### 3.3.1.2 LP-MSP430FR2476 LaunchPad™ Development Kit

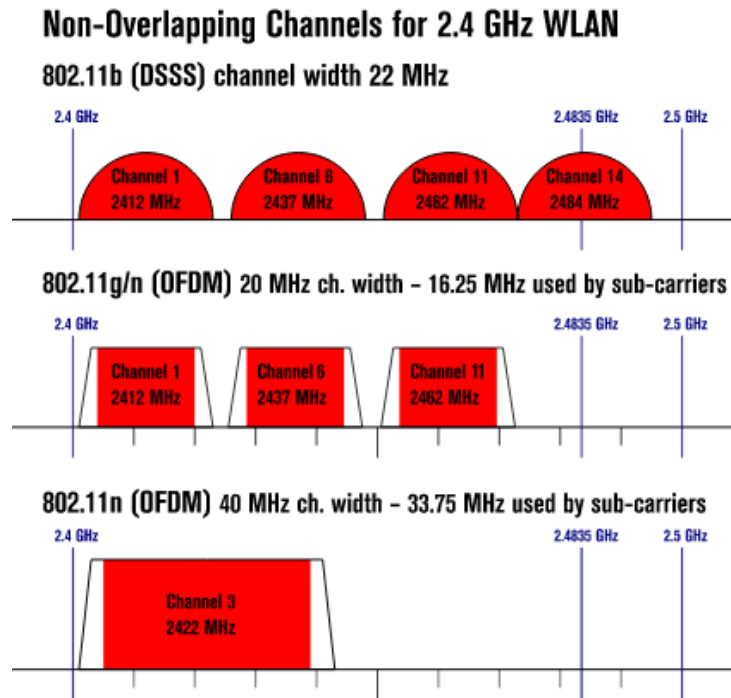
The User's Guide states that the "development kit is an easy-to-use evaluation module (EVM) for the MSP430FR2476 microcontroller (MCU). The kit contains everything needed to start developing on the ultra-low-power MSP430FRx FRAM microcontroller platform, including onboard debug probe for programming, debugging, and energy measurements." [44] One of the key features that the development kit has is the ez-FET debug probe. This device communicates with the microcontroller using JTAG and enables us to program and debug our MSP430FR2476 with ease. The development kit also has implemented 40 accessible GPIO from the MSP430FR2476. This board does not utilize all the available pins of the microcontroller, but it still provides us with ample GPIO pins. The price of the development kit is more expensive than just the microcontroller coming in at a price of \$15 as compared to \$3.45 for just the MSP43FR2476. The cost increase is justified as we would need additional parts and a PCB if we went with just the microcontroller. The features provided by the development kit will speed up the development of our project greatly.

### 3.3.2 Wireless Data Communication

Wireless data communication allows data to be transferred between devices without the need for a physical medium. Radio waves are by far the most common for use in wireless technology and can provide variable distances from a few meters to millions of kilometers. There are many different communication technologies differing in coverage range and performance. Some common examples are Wi-Fi, and Bluetooth.

#### 3.3.2.1 Wi-Fi

Wi-Fi “is a family of wireless network protocols, based on the IEEE 802.11 family of standards, which are commonly used for local area networking of devices and Internet access, allowing nearby digital devices to exchange data by radio waves.” [3] The frequency ranges provided by the 802.11 standard for use in Wi-Fi communications are 900 MHz, 2.4 GHz, 3.6 GHz, 4.9 GHz, 5 GHz, 6 GHz, and 60 GHz bands. These bands are further divided into channels which are regulated by countries individually. As the frequency increases you can expect to see higher throughput. The opposite applies for the range of communication. As the frequency increases, the range decreases. Common frequency ranges include the 2.4 GHz and 5 GHz bands along with some common protocols being 802.11b/g/n and 802.11ac/n, respectively. Differences in protocol include supported bands, bandwidth, modulation, and maximum data rate. The diagram below shows some of these differences for select protocols. IEEE 802.11 will be discussed further in the related standards section.



**Figure 3.3.4** North America Wireless LAN Channels in 2.4 GHz band

To make sense of wireless communication over Wi-Fi network you need to have a common form of communication. The Internet Engineering Task Force (IETF) provides standards for the internet and similar computer networks. The internet protocol suite (TCP/IP) is a

set of communication protocols based on the IETF technical standards. “The Internet protocol suite provides end-to-end data communication specifying how data should be packetized, addressed, transmitted, routed, and received.” [6] This set of protocols commonly sits on top of the Wi-Fi protocols completing the communication network and is the most widely used set of protocols for internet and local network communications.

### 3.3.2.2 Bluetooth

“Bluetooth is a short-range wireless technology standard that is used for exchanging data between fixed and mobile devices over short distances and building personal area networks (PANs).” [14] Bluetooth was originally standardized by IEEE as IEEE 802.15.1 but has since switched hands and is now overseen by the Bluetooth Special Interest Group (SIG). Bluetooth operates in the range of 2.402 GHz to 2.48 GHz in the ISM bands. Bluetooth is divided into 79 designated channels each with a bandwidth of 1 MHz. There are many variations of Bluetooth, one being Bluetooth Low Energy (BLE) which reduces cost and power consumption considerably while keeping a similar distance for communication. BLE uses the same ISM bands as Bluetooth but is instead divided into 40 channels with 2 MHz bandwidth.

### 3.3.2.3 Comparisons

When selecting a wireless data communications technology, it is important to select one that stays within our requirements and constraints. We looked at two different wireless data communications technologies that provide very similar benefits, Wi-Fi and Bluetooth. When looking at the two technologies some of the main characteristics taken into consideration are broken down below:

- Range: We need to be able to establish and maintain a connection within and close to the greenhouse.
- Power Consumption: Running off solar power requires us to limit our power usage throughout our design. We must look for an option that has low power consumption to ease the strain on our system. Typically, Wi-Fi is seen as using much more power than Bluetooth. This depends on the setup and optimizations.
- Throughput: Having high throughput is useful for handling inputs quickly. Even though we will not be sending or receiving substantial amounts of data, having a high throughput would be beneficial to the speed of the system.
- Cost: With a limited budget we must conserve funds wherever we can. Depending on how each technology is implemented, there are options for each that are inexpensive.

	Wi-Fi	Bluetooth
Range	9.1 m – 70 m	10 m – 100 m
Power Consumption	.0231 mW - 1.16 W	.01 mW – 100 mW
Throughput	2 Mbps – 10 Gbps	732.2 Kbps – 50 Mbps
Cost	< \$5	< \$5

**Table 3.3.2** comparison of Wi-Fi versus Bluetooth

After reviewing each technology, we selected Wi-Fi as our wireless communication technology.

### 3.3.3 Wi-Fi Module

A Wi-Fi module is connected to a device to provide access to a WLAN. There are many options when looking for a Wi-Fi module like those provided by Texas Instruments and Espressif Systems. A Wi-Fi module supports IEEE 802.11 standards and is typically used alongside a complete TCP/IP protocol stack. It is important to note that TCP/IP is software-implemented, whereas 802.11 is implemented in hardware. A Wi-Fi module can act as either a client, access point, or both client and access point. In client mode, the module intends to connect to a WLAN. In access point mode, the module intends to set up an access point for other devices to connect to the WLAN. Typical frequency bands for the modules are 2.4 GHz and 5 GHz. Wi-Fi modules contain a microcontroller with a highly integrated Wi-Fi system on chip (SoC). These MCUs come with peripherals such as UART, SPI and GPIO to allow for communication in embedded systems. The MCUs on these modules integrate on-chip “antenna switches, RF balun, power amplifier, low noise receives amplifier, filters and power management modules.” [7] Modules provided by Texas Instruments and Espressif Systems also come with several low-power modes in order to increase power efficiency.

#### 3.3.3.1 Comparisons

The main task of the Wi-Fi module is to facilitate communication between the off-chip microcontroller and the user’s device. The module needs to use IEEE 802.11 standards and implement the TCP/IP protocol stack. When selecting a Wi-Fi module, we must select one that can not only implement these tasks but stays within our design specifications and constraints. The characteristics that determined our selection of a module are broken down below.

- Power Consumption: Running off solar power requires us to limit our power usage throughout our design. We must look for an option that has low power consumption to ease the strain on our system.
- Peripherals: The Wi-Fi module needs to communicate with the off-chip MCU. The communication protocols used by our off-chip MCU include UART, SPI, and I2C. The Wi-Fi module must implement at least one of these protocols.
- Throughput: Having high throughput is useful for handling inputs quickly. Even though we will not be sending or receiving substantial amounts of data, having a high throughput would be beneficial to the speed of the system.
- Cost: With a limited budget we must conserve funds wherever we can. Luckily, there are many low-cost Wi-Fi module options to choose from.



	<u>CC3100MODR11MAMOB</u>	<u>ESP-WROOM-02</u>	<u>ESP32-C3-MINI-1-N4</u>	<u>ESP-01S</u>
Feature	Wi-Fi	Wi-Fi	Wi-Fi	Wi-Fi
Throughput	16 Mbps / 13 Mbps	72.2 Mbps	150 Mbps	72.2 Mbps
Current Consumption	7uA - 272mA	20uA - 170mA	5uA - 350mA	10uA - 300mA
Op. Temperature	-20C ~ 70C	-40C ~ 85C	-40C ~ 85C	-40C ~ 125C
UART	1	1	1	1
SPI	1	1	1	1
I2C	0	1	1	1
Cost	\$16.78	\$3.00	\$1.88	\$6.59

**Table 3.3.3** Comparison of different Wi-Fi modules.

The Wi-Fi module selected for our design is the ESP-01S. The main reasons behind our selection were the availability of communication protocols, low price, high throughput, and low current consumption. Another reason this module was selected is because it helps to significantly simplify the PCB design.

### 3.3.4 EC/TDS Sensor

To provide our plants with the best possible nutrients we must have a way to measure the nutrients in the water. One way to do this is with the use of an EC/TDS sensor. “TDS, in layman’s terms, is the combined total of solids dissolved in water. EC is the ability of something to conduct electricity”. [36] TDS is measured in parts per million (ppm) while EC is measured in micro-Siemens per centimeter (uS/cm). Often EC and TDS are linked directly to one another due to how time-consuming TDS is. A linear relationship is given: “ $TDS = k_e * EC$  where  $k_e$  is a constant of proportionality.” [40] Typically larger EC and TDS values indicate less clean water. These sensors can be seen in many applications involving smart agriculture.

#### 3.3.4.1 Comparisons

There are many options when selecting an EC/TDS sensor, so it is important to find the option that best suits our needs. When comparing EC/TDS sensors there are several things to look for. Those characteristics are discussed below.

- **Power Consumption:** Running off solar power requires us to limit our power usage throughout our design. We must look for an option that has low power consumption to ease the strain on our system.
- **Measurement Range:** Different plants require different amounts of nutrients requiring us to need a large range. A few examples of some of the TDS ranges that could be seen include lettuce with a range of 560 - 840 ppm, broccoli with a range of 1960 – 2450 ppm, and Cauliflower with a range of 1050 – 1400.
- **Accuracy:** Plants grow at their best when they are supplied with the proper nutrients. Incorrect measurements from the sensor will cause incorrect nutrients to be supplied or withheld, hindering plant growth

- Reliability: As this project is expected to operate for a long period of time it is important for our selection to be reliable.
- Cost: With a limited budget we must conserve funds wherever we can.

	S-EC-01	SEN0244
Power Consumption	.96 W – 1.92 W	.0099 W - .033 W
Measurement Range	0 – 10000 ppm	0 – 1000 ppm
Accuracy	± 3 %	± 10 %
Cost	\$139.00	\$11.80

**Table 3.3.4** Comparison of S-EC-01 and SEN0244

Taking everything into consideration, the part we selected was the S-EC-01. Our main concerns were the measurement range and accuracy of the sensor. The SEN0244 had far too low of a range and accuracy for us to use it within our design forcing us to go with the more expensive option of the S-EC-01.

### 3.3.5 Liquid Level Sensor

In order to monitor and maintain the levels of the different reservoirs liquid level sensors must be used. There are several different types of liquid level sensing technologies. One such technology, optoelectronic level sensors as seen in the optical considerations section 5.2.5, is just one example. Other technologies include float level sensors and liquid conductivity sensors. A float level sensor also commonly referred to as a float switch uses a float attached to a rod which raises and sinks as the water level fluctuates forming and breaking a connection, acting as a switch. This type of sensor is great for low power systems as it requires no power supply to operate. Liquid conductivity sensors detect the presence of a liquid when the liquid shorts the sensor signal to ground. These sensors provide either a digital or an analog output and have low power consumption.

#### 3.3.5.1 Comparisons

When selecting a liquid level sensor for our design, we had many options to choose from which would have worked for our design. The main characteristics we looked for when selecting a liquid sensor are as described below.

- Power Consumption: We are using a supply of power that is limited so we need to make sure we use as little power as possible in every area of our design.
- Reliability: We want to make sure all the parts used in our design can withstand constant usage over a long period of time. Poor reliability in our system will require maintenance taking away from the self-sustaining aspect.
- Cost: With a limited budget cost is always a factor. We will also need to incorporate several liquid level sensors into our design, so it is imperative that we look for sensors that are inexpensive.

	<u>NewZoll - Water Sensor</u>	<u>Rierdge Liquid Float Switch</u>	<u>EPTTECH FS-IR1901D Optical Infrared Liquid Switch</u>
Power Consumption	0.5 W	0 W	.5W
Reliability	Low	High	High
Cost	\$1.40	\$2.42	\$5.27

**Table 3.3.5** Comparison of different liquid level sensors.

The component selected for our design is the Rierdge Liquid Float Switch. The main deciding factors for selecting this component was its 0W power consumption and its high reliability.

### 3.3.6 UART to RS232 Converter

Spectrometers provided by Ocean Optics communicate using RS232. RS232 communication is very similar to that of UART differing only in the voltage levels determining high and low I/O. Due to their similarities it is possible to communicate between the two protocols by switching the voltages of high and low values to their appropriate levels for each protocol. One way to accomplish this is by using drivers and receivers.

#### 3.3.6.1 Comparisons

When selecting a component that can perform this operation there many factors to consider. The main characteristics we looked for when selecting a UART to RS232 are as described below.

- Power Consumption: We are using a supply of power that is limited so we need to make sure we use as little power as possible in every area of our design.
- Number of Drivers/Receivers: Depending on the application you may need more than one driver and receiver. That is the matter for our design, as we need to provide flow control to our asynchronous communication.
- Cost: With a limited budget cost is always a factor. We will also need to incorporate several liquid level sensors into our design, so it is imperative that we look for components that are inexpensive.

	<u>MAX3222</u>	<u>ADM3222ANZ</u>	<u>MAX3232EEPE+</u>
Power Consumption	889 mW	450 mW	889 mW
Number of Drivers/Receivers	2/2	2/2	1/1
Cost	\$8.06	\$5.51	\$10.58

**Table 3.3.6** Comparison of driver/receiver components.

### 3.3.7 pH Sensor

The pH sensor is tasked with reading the pH level of water being supplied to the plants in our hydroponic system. The pH value generally varies between 0 and 14. Values between

0 to 7 are considered acids while values between 7 to 14 are considered alkaline. The pH value of 7 is considered neutral and can be seen when checking the pH levels of some drinking water. The pH sensor provides a measurement in the form of a voltage. Using an ADC we are able to make use of this signal with our microcontroller.

### 3.3.7.1 Comparisons

There were several options to choose from when selecting a pH sensor. Most sensors provided similar results, however when selecting a sensor there were several characteristics we were looking for.

- Power Consumption: As in all of our components we will try to find those which require the least amount of power due to our limited power supply.
- Accuracy: Plants grow at their best when they are supplied with water that is in the range of 5.5 pH to 6.5 pH. Incorrect measurements from the sensor may cause our system to attempt to change the pH which may hinder plant growth
- Cost: With a limited budget we must conserve funds wherever we can.

	Gravity pH Meter V2.1	Grove - PH Sensor
Power Consumption	1 mW	1 mW
Accuracy	± 1.43 %	± 1.07 %
Cost	\$28.99	\$17.50

**Table 3.3.7** Comparison of Gravity pH Meter V2.1 and Grove – PH Sensor.

The pH sensor selected for our project was the Grove – PH sensor. The main reason for this selection was its reduced cost. Most of the other characteristics were comparable with only a slight change in the accuracy between the two.

### 3.3.8 Voltage Regulation

When providing a regulated power supply from an unregulated source such as a solar panel or battery, a voltage regulator must be used. A voltage regulator serves to provide a stable output voltage and the necessary current for devices requiring power from unregulated sources. When discussing voltage regulators two different forms are commonly seen: linear and switching regulators.

Linear regulators maintain a constant output voltage by varying the regulators resistance in accordance with both the load and voltage. “The regulating circuit varies its resistance, continuously adjusting a voltage divider network to maintain a constant output voltage and continually dissipating the difference between the input and regulated voltages as waste heat. “ [61] In turn linear regulators require an input voltage greater than the desired output voltage. Some key features of linear regulators are their simplicity to implement, low cost, and low noise. Linear regulators have their purposes however their core downfall is their efficiency. As they require a voltage greater than the output and excess power is dissipated as heat.

Switching regulators maintain a steady output voltage by switching on and off.” The duty cycle of the switch sets how much charge is transferred to the load.” [61]. Some key features of a switching regulator are that it can maintain an output voltage greater than that

of the input voltage. Switching regulators also dissipate close to no power resulting in high efficiency. Compared to linear regulators, switching regulators are more expensive and typically more complicated to implement.

We are sourcing power from solar panels so we must be as efficient as possible with our power. For this reason, switching regulators will be used for providing our constant output voltages. In our design we require a 12V and a 3.3V power source. This implies the need for two separate voltage regulators

### 3.3.8.1 12V Regulator Comparisons

When selecting a voltage regulator for our 12V power source, there are several different factors to consider. The characteristics that determined our selections are broken down below.

- Power Efficiency: Due to our limited power supply we need to maximize our power efficiency.
- Input voltage: We will be using a 12V battery which at any point in time can be in the range of 10.5V to 14V. Selecting a regulator that can support this range of inputs is essential.
- Output Voltage: The output voltage determines the voltage supplied to the external devices. For our 12V devices we require the corresponding output and therefore must select a regulator which can provide this voltage.
- Output Current: The output current limits the load we are able to attach to the regulator. Selecting a regulator with a large output current will allow us provide sufficient power to all the 12V devices.
- Cost: With a limited budget we must conserve funds wherever we can.

	S-8580	LM25118
Power Efficiency	95%	95%
Input Voltage	4 V to 36 V	3V to 42V
Output Voltage	2.5 V to 12 V	1.2 V to 38 V
Output Current	600 mA	10 A
Cost	\$3.86	\$2.32

**Table 3.3.8** Comparison of switching regulators S-8580 and LM25118.

The regulator selected for our design was the LM25118. This regulator has everything we require. It will support our battery's voltage range, provide us with our 12V output, and give us enough current to attach several loads. The LM25118 is slightly cheaper as well.

### 3.3.8.2 3.3V Regulator Comparisons

Similarly, to the 12V source, when selecting a voltage regulator for our 3.3V power source, there are several different factors to consider. The characteristics that determined our selections are broken down below.

- Power Efficiency: Due to our limited power supply we need to maximize our power efficiency.

- Input voltage: We will be using a 12V battery which at any point in time can be in the range of 10.5V to 14V. Selecting a regulator that can support this range of inputs is essential.
- Output Voltage: The output voltage determines the voltage supplied to the external devices. For our 3.3V devices we require the corresponding output and therefore must select a regulator which can provide this voltage.
- Output Current: The output current limits the load we can attach to the regulator. Our 3.3V power supply will not have any large load devices connected to it so having a large output current is not entirely necessary.
- Cost: With a limited budget we must conserve funds wherever we can.

	TPS62901	TPS62177
Power Efficiency	85.3%	90%
Input Voltage	3 V to 17 V	4.75 V to 28 V
Output Voltage	.4 V to 5.5 V	1 V to 6 V
Output Current	1 A	.5 A
Cost	\$0.48	\$0.50

**Table 3.3.9** Comparison of switching regulators TPS622177 and TPS62901.

The two regulators had very similar characteristics with the TPS62177 outperforming the TPS62901 slightly in power efficiency. With only a \$0.02 difference in price between the two the TPS62177 was selected. Looking at the output current .5A may seem insufficient. Our 3.3V supply will only be powering components requiring low power, so our .5A should be more than enough.

### 3.3.9 GPIO Pin Conservation

Our microcontroller is tasked with controlling numerous pumps, sensors, and purifiers. When dealing with these external peripherals, a minimum of 1 pin is utilized for each device. It is very easy to use up all the pins even on a large pin-out microcontroller. For this reason, we will seek to use pin conservation hardware such as multiplexers and decoders.

Beginning with multiplexers, these devices require  $n$  selection lines to select one out of  $2^n$  data lines to provide an output. Using an example of an 8-to-1 mux, this multiplexer requires only 3 selection lines and allows us to select one of 8 different data lines saving us 5 pins.

Similarly, decoders require  $n$  selection lines but instead of selecting from  $2^n$  data lines, decoders produce  $2^n$  outputs. At any given time, only one of these outputs will be set while the others remain low. Typically, these devices also have an enable and disable bit as well. Using an example of a 3-to-8 decoder, we once again only require 3 selection lines and can control 8 different output lines.

#### 3.3.9.1 Multiplexer Comparisons

When selecting a multiplexer for our design there were many options to choose from. The characteristics that we looked for and determined our selection are broken down below.

- Selection Lines: We want to use a minimal number of selection lines for our multiplexers to conserve pins.
- Data Lines: We want to have as many data lines as possible available for the multiplexer to choose from.
- Operating Voltage: Our microcontroller will operate at 3.3V so we must ensure that the multiplexer supports this voltage.
- Cost: With a limited budget we must conserve funds wherever we can.

	SN74HC151	CD74HCT251E
Selection Lines	3	3
Data Lines	8	8
Operating Voltage	2V to 6V	4.5V to 5.5V
Cost	\$1.16	\$0.77

**Table 3.3.10** Comparison of multiplexers SN74HC151 and CD7HCT251E.

The multiplexer selected for our design was the SN74HC151. The cost of this device is almost twice as expensive as the alternative however the operating voltage will not work with our microcontroller.

### 3.3.9.2 Decoder Comparisons

When selecting a decoder for our design there were many options to choose from. The characteristics that we looked for and determined our selection are broken down below.

- Selection Lines: We want to use a minimal number of selection lines for our decoder to conserve our microcontroller's pins.
- Output Lines: We want to have as many output lines as possible available for the decoder to choose from.
- Operating Voltage: Our microcontroller will operate at 3.3V so we must ensure that the multiplexer supports this voltage.
- Cost: With a limited budget we must conserve funds wherever we can.

	CD74HC238E	SN74HCS237
Selection lines	3	3
Output Lines	8	8
Operating Voltage	2V to 6V	2V to 6V
Cost	\$0.51	\$0.76

**Table 3.3.11** Comparison of decoders SN74HCS237 and CD7HC238E.

The decoder selected for our design was the CD7HC238E. The decoders examined were almost identical, so it came down to a slight difference in price being the deciding fact. A \$0.25 difference is not much but we are still conserving funds.

## 3.4 Water Purifiers

Our goal while selecting a water purifying system was to research and find a water purifier that utilized multiple kinds of purification, but specifically, we wanted to find a water purifier that utilized UV purification. It has been mentioned several times that hydroponic systems are intended to create a perfect environment for growth in plants, and one of the

ways in which that is made possible is by removing the need for pesticides, herbicides, and alternative plant protection methods. As a result, it becomes increasingly more important to ensure that the contents of the water being irrigated to the plant are free of any potentially harmful contamination since there is not any added protection administered to the plant. The use of ultraviolet purification has been discussed due to its ability to kill any microorganism that may infiltrate the system. Given that this system's water supply is fed using rainwater, the overall water collection will be outdoors and exposed to nature. This of course means that as the rainwater is channeled through the exterior gutter system, passing through the air, or sitting inside the central water reservoir, there will be ample opportunity for microorganisms to grow in the water.

As we conducted our research, we found there are numerous kinds of water filtration methods which all of various advantages and disadvantages. In the following sections, we will discuss the filtration methods most relevant to the filtration we will need in this project.

### **3.4.1 Sediment Filters**

Sediment filters can be considered the first line of defense for the system as a whole. These kinds of filters are essentially used to block large types of contaminants or particulates from entering the subsequent purifying stages. On their own, they do not tend to provide enough filtration to be particularly effective outside of stopping any potential damage or breakdown of the other filters and piping. These types of filters are most often used as pre-filters for well-water as they are used to filter out larger particles like sand, silt, and rust. [57] Sediment filters are typically made from coarse or fine types of materials in which the finer the material is, the better the filtering of the material. These types of filters tend to be excellent first stage filters and will be utilized if our preliminary tests show that there are still large amounts of sediment or particulates making it through our filtration system.

### **3.4.2 Reverse Osmosis**

One of the most ideal filtration systems for us to use would be a reverse osmosis filter due to its ability to remove chemicals, particles, minerals, and salts. This is a more robust filtering process that is more commonly used for drinking water as people require much more effective filtration mechanisms for their water than plants do. However, reverse osmosis can remove contaminants including lead, nitrates/nitrites, radium, chloramine, organic pollutants including trihalomethanes; bacteria, and cysts like cryptosporidium or giardia; pesticides and herbicides; and much more. [57] This makes it incredibly effective for our system as we must ensure the plants receive the most suitable water as possible. The process of reverse osmosis works by forcing water through a semi-permeable membrane to remove dissolved solids and impurities. [58] The water is pumped into the filter from a reservoir or other water source and is forced through the membrane which halts the passage of dissolved solids and impurities while permitting the passage of water. One of the primary disadvantages of this system is that it tends to be considerably more expensive than other systems both as a fixed cost for the purchase and installation as well as a variable cost for its annual maintenance when replacing the membranes. Though it is an incredibly thorough form of filtration, the high cost makes this filter less accessible and difficult to justify for widespread applications in community gardens.



### **3.4.3 Distillation**

We have mentioned in this paper that the best method for delivering water to our system would be to first distill it before infusing it with nutrients and pH-balancing agents. This is because the only water uptake that would be occurring within the plants would be a balanced nutrient solution necessary for the proper growth of the chosen crop species. Distillation is particularly effective because it's the only way to fully eliminate bacteria such as coliform, lead, arsenic, nitrates/nitrites, herbicides, or pesticides. [57] This is accomplished by boiling contaminated water in a container to capture the steam as it rises to the top. The steam is then cooled and recondensed into clean water that is free from contamination. As one can imagine, the distillation process and equipment are very expensive. Even if we could find a way to justify the expense of the distiller in the system, we would not be able to reasonably compensate for the very high amount of energy the system takes to operate. In total, the system would be far more expensive than standard filtration methods, consume a greater amount of energy, and utilize a much larger amount of space than the other purification methods we have explored. Though it is a perfect solution to the problem of contaminated water, we don't need the solution to be perfect in order for the project to work as intended with a high degree of efficiency.

### **3.4.4 Carbon Filters**

Having considered the first line of defense and the two best options for filtration, we determined that we would need to continue researching to find the filtration method that would balance an effective solution with a low overall cost. We believe that carbon filters may be able to provide this balance when use in conjunction with another filtering system. There are two kinds of carbon filters that can be used: activated carbon blocks and granular activated carbon. Before describing each system, we believe it is important to understand what activated carbon actually is. Essentially, activated carbon is a material that is made from carbon molecules derived from carbonaceous materials, such as wood, coal, or coconut. These materials have been processed, treated, or activated by heat or steam to make an extremely porous product that has a large surface area and adsorptive properties. [59] Activated carbon works through a process called adsorption which is essentially the adhesion of molecules from a dissolved solid to a surface. [60] So, when the liquid water passes through the activated carbon, rather than having the dissolved solids also pass through, they adhere to the exterior surface of the carbon. This process is used in both types of carbon filters while being applied in different ways.

#### **3.4.4.1 Activated Carbon Blocks**

The first of the two types of carbon filter is the activated carbon block. Between the two types, this is more expensive due to the manufacturing process as well as being more effective than granular activated carbon. Activated carbon blocks are made by grinding activated carbon into a fine powder and mixing it with a binding agent so that it forms a large solid block. [57] This solid block acts as the filter, allowing water to pass through it while trapping any contaminants due to the highly porous nature of the carbon. These carbon blocks are more effective than GAC because the ground powder is creating a large amount of surface area with which to catch contaminants. The tradeoff for the increased trapping efficiency is that there is a much slower flow rate compared to GAC. [57]

## Filtration Process

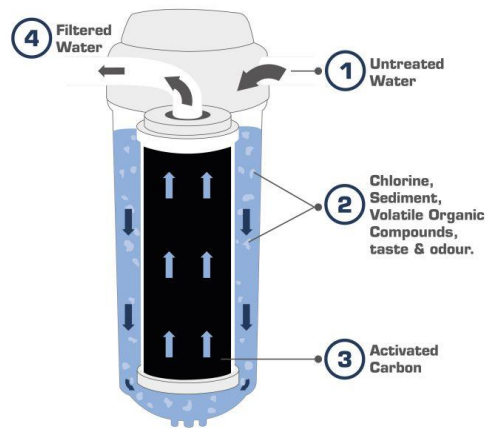


Figure 3.4.1 Activated Carbon Block Filter

The water pathway through an activated carbon block is depicted in Figure 6.4.1 before it undergoes the filtering process. These filtering blocks work using three different processes. The first process is mechanical filtration. This process could be thought of similar to how a screen door is able to block very large airborne debris from coming inside a house. As the water is forced through the small pores in the block, they restrict the movement of impurities as small as 0.5 microns while allowing the water to continue flowing through the rest of the block. [59] The second process is physical absorption which allows the negatively charged activated carbon blocks to attract the positively charged molecules in the water. This in turn makes the molecules stick to the carbon particles so they don't pass through the pores. [59] Finally, some carbon blocks are wrapped in a special membrane that induce electrokinetic adsorption. This process effectively adds an exterior positively charged membrane to the carbon block that attracts any negatively charged ionized impurities in the water. [59] Using these three methods, the activated carbon blocks are able to mechanically filter large impurities while simultaneously filtering both negatively and positively charged impurities that are not captured in the mechanical process. As a result, activated carbon blocks are able to be used an applied in a wide range of applications for very low fixed and variable costs. They are made more viable by being more effective than GAC filters as well. The main disadvantage is the lower flow rate due to the compactness of the carbon granules, and the block may require more frequent replacements compared to GAC filters.

### 3.4.4.2 Granular Activated Carbon (GAC)

While activated carbon blocks are incredibly compact carbon filters with finely ground activated carbon, granular activated carbon filters are composed of loose activated carbon granules in cylindrical containers. GAC filters use millimeter sized granules that are not adhered together to form a coarse mesh that allows water to easily pass through the cartridge. [59] The contaminants are filtered out of the water in a fashion similar to what we saw in the activated carbon blocks. The filter still allows the porous carbon granules to

absorb the contaminants while clean water passes out the other side. However, because the carbon particles are more loosely packed together, an effect known as channeling can be present in GAC filters. [59] This effect means that the water will find the path of least resistance within the filter which is typically the area with the least number of carbon particles to filter the water. As a result, a large amount of contaminated water would be able to pass through the filter without filtering compared to the activated carbon blocks. This also results in some water getting left behind in the unchanneled pathways within the filter. Water can therefore become stagnant while the other water channels through the filter. As a result, GAC filters can become mediums for bacterial growth and further contamination. [59] Even though GAC filters are the least effective method of filtering that we have discussed so far, it is incredibly accessible and affordable. Furthermore, it is well suited for systems that require basic filtration and high flow rates. Unfortunately, these filters are only suited for removing gases, vapor, chlorine, and bad odor and tastes, so they would not be effective enough on their own for our purposes in this project. That said, they could very well be coupled with other filtration methods to increase their viability.

### **3.4.5 Filter Selection**

For the filtration system, we decided it would be best to use multiple different kinds of filters to have the best filtration possible. Assuming we are unable to make room in the budget to purchase a combined reverse osmosis system, we will have to eliminate the possibility of using distillation and reverse osmosis due to the restrictive nature of the costs associated with building, installing, and maintaining those systems. We feel that it would be best to pursue a combination filtration system using a sediment filter, activated carbon block, and UV purification system. Although the fixed cost of installing three separate systems is expected to be higher than only pursuing a single high end filtration system, we believe the use of the varying filtration systems will result in the highest purity water system for the plants with the lowest variable costs to maintain the system annually. To combine these systems, we will first pass the water through the sediment filter to remove any large particles and debris from the water before passing it through the activated carbon block. By doing this, we will reduce the amount of filtering work the carbon filter will have to do on the water which should also increase the lifespan of the filter compared to if the water was not prefiltered. The carbon filter will be able to remove chemicals, particles, and molecules from the water to reduce the number of dissolved solids in the water. The last portion of the filtration process will be an ultraviolet filter to eliminate any microorganisms that may have passed through the first two filters. Having a cascading filtration method like this will increase the lifespan of each subsequent filter while also improving the overall filtration process for the rainwater collection system. In doing so, we will have increased the efficiency of the purification process while simultaneously reducing the maintenance costs associated with the systems on an annual basis due to reduced system strain.

#### **3.4.5.1 Ultraviolet Light Plus Sediment & Carbon Well Water Filter Purifier System**

Bluonics creates very reliable and effective water filtration systems utilizing various kinds of filtering systems. In this case, we found a filtration system intended for use with well water that makes use of a string wound sediment filter, five-micron activated carbon block filter, and a one-micron sediment filter before passing through a UV sterilizer.



**Figure 3.4.2** Bluonics 4-Stage UV Purification System

This system is very heavy duty and can process as many as twelve gallons of water per minute. However, this system is the most expensive we have considered, and it could only be made accessible through further sponsorship beyond what we have already received. The price of this system is \$597, including the entire system and the cartridges for the filters. When in use, the filter uses 55 Watts of power which is a considerable amount given we are trying to keep our total power consumption under 300 Watts of power at the high end. Due to the high cost of this system, we did not feel as though we could justify the purchase of such a system.

### **3.4.5.2 Ultraviolet Reverse Osmosis Water Filtration System**

We have conducted research into the best preconstructed combination systems that we could purchase for our project. The water filter that would provide the greatest methods for filtration is from Express Water, and it features a six-stage filtration system. Though typically used in a house underneath a standard kitchen sink, this system can be applied to our project to output excellent quality water.



**Figure 3.4.3** Express Water 6-Stage Water Purification System

This water purification system utilizes almost every kind of filtration system discussed so far within our research. Looking in the image above, we find the system makes use of a preliminary sediment filter before passing through a two-stage carbon filter. It moves first through a granular activated carbon filter before reaching an activated carbon block. Once it passes through the ACB, it is run through a reverse osmosis filter directly into an ultraviolet purifier. The last stage is a post-activated carbon filter to round out the system. While this system boasts an impressive array of purifying agents, it is still slightly more expensive than we would hope for us to purchase it. This system costs \$340, and it comes with several unnecessary components such as a sink faucet. However, this system can handle processing as many as 100 gallons of water per day which is a considerable amount and would be ideal in the event the system has to be purged of water and refilled. Another perk of this purification system is that it is upgradable, so we could potentially add a water chiller, alkaline water filter, and deionization filter if we deem it necessary.

### **3.4.5.3 Bluonics 4 Stage Purifier/Filter System**

The cheapest system we found that still appears viable for the application we are seeking in our rainwater collection system is Bluonics Under Sink Purifier/Filter System. This system utilizes a pre-filter sediment filter, a granulated carbon filter, and an active carbon block before the filtered water is passed through a 6-Watt UV purifier. Though the system is intended for under sink use, the company explains that this system is usable in mobile environments such as RVs and boats demonstrating the versatility of this system. This system is also the cheapest of the three purifiers we examined during our research with a relatively cheap price tag of \$157 which is right within our budget of \$150. We expect that this system would work well to remove the larger scale particulates from the water even though it may not be the most effective filter between the three. Our current projection is to use this filter for our system; however, we are going to specifically seek additional sponsorship money to upgrade this filter the Express Water 6-Stage Water Purification System. This system will be perfectly functional for our application even if it is unable to create a perfectly filtered water source for the hydroponic systems. This is also a more

accessible system for any future applications of our system as a community garden around other municipality. The filtration system is depicted below.



**Figure 3.4.4** Bluonics Under Sink Water Filtration System

### **3.5 Liquid Pumps**

This system will require a large amount of movement of the various liquid contents we are including for the growth of the plants. From pumping water to the sub-reservoirs to balancing the pH of the water, we needed to conduct a large amount of research into the types of pumps that would be used and needed for the system to function. Unfortunately, we are not able to simply use submersible pumps for all of our applications due to the need to have very specific pump rates to properly measure the quantity of balancing agents we are pumping into the system. Thus, this section describes the research we conducted into the types of water pumps that we have considered using in the system.

#### **3.5.1 Submersible Pump & Non-Submersible Pump**

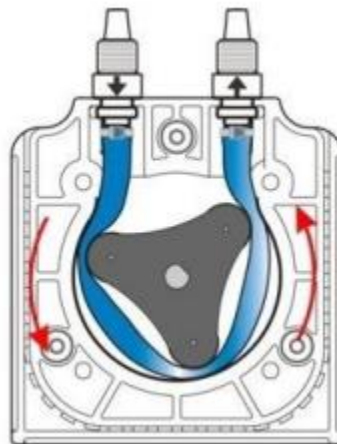
A submersible pump and non-submersible pumps allow for liquid to be transported to a surface by pushing the fluid. This holds an advantage to jet pumps in lots of applications which rely on a vacuum created by atmospheric pressure.

Submersible pumps allow the whole piece to be submerged fully in the liquid that is being pumped. This adds a benefit over its non-submersible counterpart since it can prevent pump cavitation since the whole assembly is being submerged. These pumps are multistage centrifugal pumps. By converting kinetic energy in a diffuser, pressure energy can be created. Non submersible pumps work on a similar way however are not subject to being submerged in the fluid it is pumping but rather uses piping to pump liquid from end to end. This type however is perceptible to pump cavitation if used with high pressure liquids.

### 3.5.2 Peristaltic Liquid Pump

When it comes to pumping water for lots of applications the exact precision of the dispensed water doesn't take as much precedent in the design since in lots of applications having accurate measurements to the millimeters would just cause inefficiencies and an excess of unrequired materials. When an application however calls for the use of a very precise amount of a liquid being dispensed some pumps specialize in just this. A peristaltic pump is one of such pumps that can dose small volume point-of-care liquids.

Peristaltic pumps use a form of positive displacement for pumping various liquids. Its commonly used to pump sterile and clean fluids that are needed in a very precise amount. Since the pump and mechanism, itself never sees the fluid due to it being transported purely through piping and tubing.[50] Rollers are pressed up against the inner hose and pinches the tubing in section moving the liquid through. By using rollers to move the liquid a siphon is created allowing for more liquid to be brought up the tube in the process.



**Figure 3.5.1** internal view of a rotary peristaltic pump.[50]

This lends a great option for us when used to transport our nutrient and pH balancing liquids due to its ability to transport very precise amounts of solution without contacting possibly corrodible parts that are used in a normal pump system. Being able to accurately measure and mix the nutrients and pH liquids into the water to create a good nutrient solution will allow for proper nutrients for the plant to absorb.

### 3.6 Hydroponic Techniques

When looking at cultivation of plants using a hydroponic system you need to choose which type of hydroponic system fits best in what you are trying to achieve. Out of many different varieties to choose from the main types of systems that make up hydroponics are wick-based systems, drip systems, Ebb and flow, deep water culture (DWC), aeroponic systems, and nutrient film technique hydroponics. Each system works a little different depending on the use and type of growing medium, the implementation of pumps and timers, and depending on the type of crop specifically planning on being grown in the system. Out of all these methods we must take careful consideration on differing between them to locate the best technique for our application.

### **3.6.1 Wick Hydroponic System**

The most straightforward technique of the bunch in hydroponics is the wick system. Many benefits of the wick hydroponic technique come from how simple it is when compared to that of other hydroponic systems. The wick system is made up of no moving parts, pumps, or even electricity to utilize the technique. Wick irrigation systems operates in a closed cycle. This creates a system without runoff allowing for appropriate plant nutrition and even distribution through a system. Wick systems are advantageous because: 1) they are independent of electrical need for operation; 2) You have access to control the temperature of the root system itself; 3) they require mess management and manpower; 4) the final produce is highly uniform; and 5) they require less water use than other hydroponic systems. [31] The wick system seems to be a prime candidate when it comes to certain vegetables or aromatic plants. Wick systems however can be difficult to work with for a variety of different plant selections and doesn't allow for that much control over what is happening to the system. Though simple and a great choice for home applications this system didn't seem ideal for our goals of having a system completely under our control that is able to support many different types of crops at the same time.

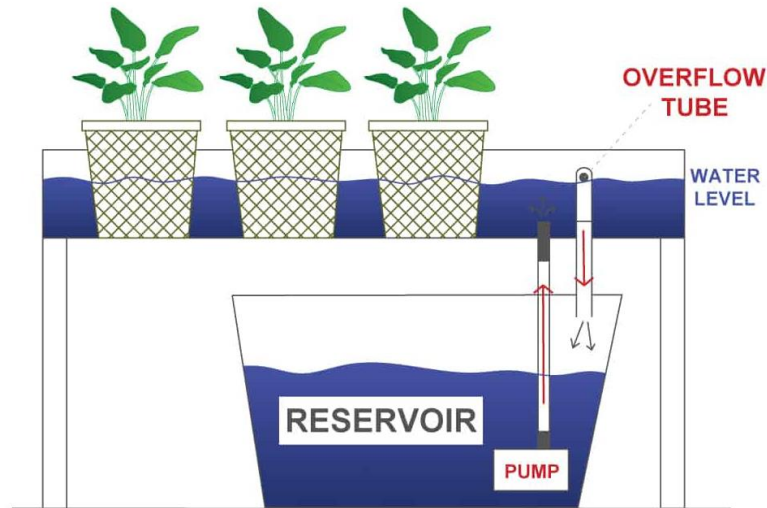
### **3.6.2 Drip Hydroponic System**

Drip hydroponic systems are commonly used in both home gardening and in commercial uses. It is also simple in concept like the wick system. The idea is to have a simple slow feed of nutrient rich solution constantly dripping onto the substrate and roots of the plant. This system constantly recycles the nutrient water solution back to the reservoir through draining in the wave of the plant bed. This ensures that the roots of the plant are constantly staying moist and healthy enough. These ease and reliability that this type of system provides makes it one of the most used types of hydroponics commonly found. Even though this system has many benefits especially when it comes to how easy it is to setup and use it requires lots of maintenance and babysitting of the plants. When dealing with a drip system you must ensure that your flow is enough that the plant is able to receive the water and nutrients it needs. It is also crucial that the draining is also adequate for the plant, or you could risk drowning the plant if its flow is outweighing the draining process. One of the major downsides of the use of drip hydroponics for us was the fact that due to its recycling of water back into the system the PH and nutrients of the solution is constantly changing which can lead to uneven plant growth if you are unable to read such measurement and make corrections to balance the required nutrients and PH needs of the plant.

### **3.6.3 Ebb and Flow**

Ebb and flow systems, also known as flood and drain systems, work through flooding nutrient rich water into the growing plant bed for specific segments of time. After flooding the plants, the water solution is then evacuated slowly into the initial reservoir to be used again in the plant system. This method uses water pumps and timers to flood the system and usually a gravity fed method to drain it afterwards.





**Figure 3.6.1** Ebb and flow hydroponic system highlighting the flooding system used in the technique. [35]

The benefits behind the Ebb and flow system are great for plants that require lengths of time where the foot system needs to be dry rather than constantly moist. This dryness aids in root expansion for the plant as well.[32] because of the cycle of flooding and draining that occurs within the system, constant monitoring of soil moisture and nutrients levels are needed to be maintained so that the nutrients and water solution can be flooded back into the system without the risk of causing hard to the plant through overwatering.

### 3.6.4 Deep Water Culture (DWC)

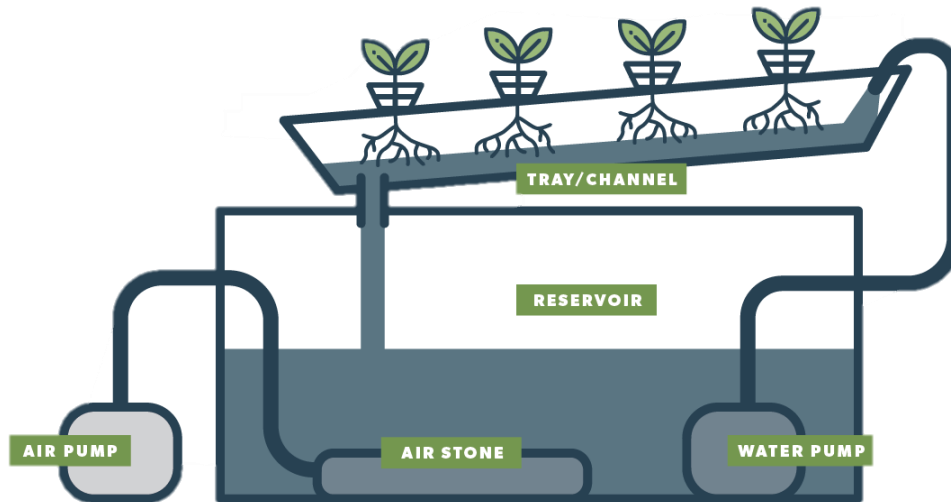
Deep water culture, also known as deep flow technique, is a hydroponic system that cultivates the plants on floating supports submerged in nutrient solution. Floating rafts are used to support the plants above the water while the plants' root system is submerged in water. This is beneficial because it can minimize costs and management because there is no need for sensing or checking on the plants because they are constantly being provided with moisture and nutrients. Oxygen is constantly having to be pumped to the root system to ensure that they get the required oxygen levels they need. This technique can be great in many applications however it is limited on the types of plants that can be grown in such a system. For our use this system wouldn't be ideal. Our goal of being able to adapt the system to accommodate a large variety of different crops.

### 3.6.5 Aeroponics

Aeroponics is a hydroponic technique that is aimed at smaller horticultural species. Unlike lots of the previous mentioned methods it is not widely used because it has high initial investment and upkeep costs associated with the system. In this hydroponic system plants are supported by panels with their root systems being directly exposed to air. Nutrient solution is directly sprayed onto the roots to provide the plant with the water and nutrients it needs. The time of spray applied to the roots changes in length and frequency depending on the plant and the growth state that its currently in. [38] Aeroponics has many benefits to support its high cost. Due to its aerated roots a high supply of oxygen is provided to the roots for plants that require high oxygen levels to grow properly. Also, since the plant is

not exposed to soils and other aggregate media it is hard for an aeroponic plant to contract a disease that might be introduced through soils. This resistant is significant in preventing root rot and seedling blight. This system is very case specific and noncommercial however so it would not be the best for our application.

### 3.6.6 Nutrient Film Technique (NFT)



**Figure 3.6.2** Nutrient film technique system highlighting a pump and channel fed cycle. [36]

Nutrient Film Technique is considered the classic hydroponic cultivation system. Nutrient solution flows and circulates through channels fed through water pumps and traditionally is gravity fed back to the initial reservoir for the water to be recycled into the system. The absence of substrate and recirculation of nutrient and water solution allow for less maintenance and cheaper costs than other hydroponic systems. NFT systems also have the advantage that they have the most potential out of most of the other hydroponic systems for automation that can save on required maintenance.

During consideration on which hydroponic system we would utilize for the use of a self-sufficient hydroponic greenhouse we decided to use the nutrient film technique due to its relative reliability and its ability to be able to grow a variety of different crops through multiple channels. Among the many considerations made while selecting a hydroponic technique to utilize, maintenance was high on the list. One of the primary goals of the project is to minimize the maintenance required on the system to drive the need for people down. In NFT systems, the constant flow of water on an incline channel reduces the amount of salt buildup in addition to acting as a self-cleaner. This is coupled with the fact that nutrient film techniques are typically more efficient at distributing nutrients compared to the other hydroponic systems. If nutrients are used more efficiently, this in turn means that the nutrients will not be spent as quickly which will require significantly less replenishment over the long term.

Additional factors we considered when selecting our system include scalability, cost, and ease of use. Discussing scalability, nutrient film technique is certainly the most easily scaled hydroponic technique due to the fact that it utilizes gravity as the main method of

nutrient distribution. It is a simple matter to make an NFT system longer, taller, or wider to increase the overall crop production because one must simply pump the nutrient rich solution to the top of the incline growth channel in order to allow for every plant to receive a portion of the nutrients. However, it is well worth noting that one of the primary drawbacks of nutrient film technique is an unequal distribution of nutrients which can reduce the yields and growth rate of some plants in the system while dramatically increasing the same metrics in other plants. This is attributed to the fact that the plants at the top of the channel will have immediate access to all the nutrients the system will intake as soon as they are pumped to the top. As a result, the plants at the bottom of the growth channel often do not receive as many nutrients as those at the higher sections of the tray.

The scalability of NFT is comparable to that of both the ebb and flow technique as well as the aeroponics technique; however, each of the latter two techniques have other drawbacks aside from the physical scale. The ebb and flow technique for example requires more water at any given time during the “flow” cycle than the NFT technique does. This means that during dry spells for the greenhouse as a whole, NFT would be better suited to grow more plants due to the constant use of a small amount of water. Aeroponics on the other hand can be easily scaled vertically and horizontally due to nature of its deposition being based on aerial distribution. However, aeroponics results in less efficient use of the water supply as a result of the plants not being partially or fully submerged in the solution. Since the nutrient solution is sprayed as opposed to being pumped, the system experiences greater losses due to evaporation. This coupled with the high initial investment required to make a suitable aeroponic system made this an unachievable goal for a hydroponic system.

Of course, cost is always one of the biggest constraints and a primary consideration for any system. While NFT systems are not the cheapest possible hydroponic system we could build, it is still an incredibly cost-effective method. In the case of hydroponics, typically the wick technique is the cheapest method as it has very few technical systems and requires little to no electronics to operate. It also has the lowest initial investment with minimal maintenance required. However, the wick technique is also the most inefficient technique with regard to the distribution of water and nutrients. Because the solution must travel through an absorptive medium to pass from the reservoir to the plant, there are massive losses of nutrients to the wick which simultaneously causes a buildup of nutrients, salt, and contaminants. This results in the wicks needing to be replaced under regular maintenance. The last major issue with wick technique is that it is not easily scaled to larger size gardens. Due to the fact that every additional plant must have a wick placed between the reservoir and its growth area, it slows down the planting process significantly.

Finally, ease of use was both applicable to the use of the greenhouse by nontechnical personnel and to the actual construction of the project. We are in full recognition of the fact that this project is a large undertaking, so we wanted to find the system that would be both easy to design initially but also easy to maintain by a group of volunteers after the greenhouse is committed to a group for use as a community garden. Therefore, we wanted to select a hydroponic technique that would be simple for everyday people to be able to work with without any prior knowledge about agriculture or technical systems. At a surface level observation, we explored the drip, wick, and nutrient film techniques as the most

likely contenders for being the simplest to use systems. While all three systems are relatively easy to construct, the long-term use of the systems was the ultimate consideration over which would be the easiest for the average person to use. The drip technique, though widely applied and available, requires much more regular care and maintenance of the plants to monitor their overall health. It is not a technique that is friendly to the idea of making a largely self-regulating system. The wick technique is a very simple system to interact with and maintain on the face, but there are too many inefficiencies that exist when using such a technique that it too hinders the self-regulation of the system. This is how we finally arrived at the nutrient film technique as the most user-friendly system. The plants are easily accessed, harvested, replaced, and maintained in a free-flowing systems that keeps itself free major internal waste buildup.

## **4.0 Related Standards and Design Constraints**

Standards are agreed upon specifications that lay out how a material, product, or service is to be established and are typically used to maximize reliability and efficiency. Standards can provide a framework for enabling different devices to communicate with one another. For our design, several standards will be used to guide us in the development process.

### **4.1 Related Standards**

The Institute of Electrical and Electronics Engineers (IEEE) is one of the largest standards associations with over 1200 published standards. The IEEE provides a plethora of standards, including “power and energy, artificial intelligence systems, internet of things, consumer technology and consumer electronics, biomedical and health care, learning technology, information technology and robotics, telecommunication, automotive, transportation, home automation, nanotechnology, information assurance, emerging technologies, and many more.” [17] Standards from IEEE will be maintained to facilitate the design process and stay within the regulations imposed by our government.

The International Organization for Standardization (ISO) and the International Electrotechnical Commission (IEC) form the joint technical committee ISO/IEC JTC1. ISO/IEC JTC1 “is a consensus-based, voluntary international standards group.” [18] This committee is responsible for standards related to information and communications technology.

The American National Standards Institute (ANSI) “is a private non-profit organization that oversees the development of voluntary consensus standards for products, services, processes, systems, and personnel in the United States.” [23] It is important to note that ANSI does not create standards but instead “oversees the development and use of standards by accrediting the procedures of standards developing organizations.” [23]

#### **4.1.1 Wi-Fi Standard**

The IEEE provides a family of standards denoted IEEE 802 used for local area networks (LAN) personal area networks (PAN), and metropolitan area networks (MAN). [20] In terms of the Open Systems Interconnection (OSI) networking model, IEEE 802 provides the first two layers; physical and data link. The physical layer is the first layer of the model and refers to the connection medium. The data link layer is the second layer of the OSI model. This layer “transfers data between nodes on a network segment across the physical layer.” [21] IEEE 802 breaks this layer down into two sublayers; logical link control (LLC) and medium access control (MAC). IEEE 802.11 is part of IEEE 802 and specifies the set of MAC and physical layer protocols for implementing wireless local area network (WLAN) computer communication. [5] Typically this standard is used along with IEEE 802.2 which defines LLC as the upper portion of the data link layer [22] and is often used to carry Internet Protocol (IP) traffic.

The IEEE 802.11 standards are implemented in the Wi-Fi module. IEEE 802.11 has several amendments with some of the more common being IEEE 802.11b, IEEE 802.11g and IEEE 802.11n. The key differences in each of these standards are operating frequencies, bandwidth, throughput, and range of connectivity.

Standard	IEEE 802.11b	IEEE 802.11g	IEEE 802.11n
Frequency	2.4 GHz	2.4 GHz	2.4/5 GHz
Bandwidth	22 MHz	5/10/20 MHz	20 MHz or 40 MHz
Throughput	11 Mbit/s	54 Mbit/s	288.8 Mbit/s or 600 Mbit/s
Indoor Range	20 m	38 m	70 m

**Table 4.1.1** Comparison of different Wi-Fi standards.

This module conforms to these standards which can be further specified by their physical layer standards.

#### **4.1.2 C Programming Language Standard**

The ISO/IEC subcommittee ISO/IEC JTC1/SC 22 in accordance with the American National Standards Institute (ANSI) provide standards for the C programming language. The most recent standard as of June 2018 is ISO/IEC 9899:2018 more commonly referred to as C17 or C18. As a side note, this standard is expected to be superseded in 2023 by C23. C18 defines the form and interpretation of software written in the C programming language. C18 specifies the representation of programs, the syntax and constraints of the C language, the semantic rules for interpreting C programs, the representation of input data to be processed by C programs, the representation of output data produced by C programs, and the restrictions and limits imposed by a conforming implementation of C. [19]

This standard has clearly defined conformance for our C language software. During the design and implementation of the software we need to follow and review these guidelines to meet conformance to the standard. C18 details many different nuances such as scope of identifiers, different variable types and conversions, and lexical elements which will be useful to the software programmer.

#### **4.1.3 Water Quality Standards**

Water quality plays a significant role when it comes to a plant's growth. The United States Environmental Protection Agency puts out standards on water conditions for fishing, recreation, and human health when it comes to water. However, The Environmental Protection Agency does not provide clear standards for water use when it comes to agricultural processes. Being able to follow the Environmental Protection Agency is necessary task when dealing with anything regarding water.

The Water Quality Standards provided by the Environmental Protection Agency outlines and documents expectations for water use. For most cases these regulations are made for wildlife preservation, recreation, drinking, and agriculture. These regulations are very well defined and vast including the expectations on pollutant concentrations found in different waters depending on the condition of use.

Water analysis standardization is a well-documented and covered standard due to its impact on the environment as well as people. One group that works with standardizing water analysis and testing is the American Society of Testing and Materials. This organization

is an international group that publishes technical standards for products, systems, and materials. One that we had to focus on was its standards in water testing. American Society of Testing and Materials has documented standards on many characteristic traits of contaminated water that can be a concern for health, and environmental purposes. These water standardizations are used by water distribution facilities and laboratories to test water samples and ensure that the water is safe for human consumption.

Since we focused on water sampling and analysis using Raman spectroscopy not many standards exist in such field since the technique is not widely commercialized for this use case. Because of this an emphasis was set on standards directly using and talking about Raman spectroscopy.

When dealing with our hydroponic system it is necessary for the plants to be able to healthy. This information can be analyzed through electrical conductivity and pH measurements. The electrical conductivity gives us insight into water quality which is necessary in ensuring proper plant growth. The basic concept behind electrical conductivity is that it measures the concentration ions that is found in the water. This can tell us the nutrients found in water because the higher the ion concentration the more nutrients since nutrients are better at conducting. Using just water however would be a bad conductor of nutrients. A balance of electrical conductivity must be achieved for a plant to thrive. If These values are too high, then a plant would be subject to high toxicity. If not enough nutrients are provided to the plant, then it will not be able to grow and produce for the greenhouse system. Electrical conductivity is not a system that can be applied to every plant the same. Different plants differ the level of electrical conductivity needed to produce the best crop.

Crops	EC (mS/cm)	pH
Asparagus	1.4 to 1.8	6.0 to 6.8
African Violet	1.2 to 1.5	6.0 to 7.0
Basil	1.0 to 1.6	5.5 to 6.0
Bean	2.0 to 4.0	6.0
Banana	1.8 to 2.2	5.5 to 6.5
Broccoli	2.8 to 3.5	6.0 to 6.8
Cabbage	2.5 to 3.0	6.5 to 7.0
Celery	1.8 to 2.4	6.5
Carnation	2.0 to 3.5	6.0
Courgettes	1.8 to 2.4	6.0
Cucumber	1.7 to 2.0	5.0 to 5.5
Eggplant	2.5 to 3.5	6.0
Ficus	1.6 to 2.4	5.5 to 6.0
Leek	1.4 to 1.8	6.5 to 7.0
Lettuce	1.2 to 1.8	6.0 to 7.0
Marrow	1.8 to 2.4	6.0
Okra	2.0 to 2.4	6.5
Pak Choi	1.5 to 2.0	7.0
Peppers	0.8 to 1.8	5.5 to 6.0
Parsley	1.8 to 2.2	6.0 to 6.5
Rhubarb	1.6 to 2.0	5.5 to 6.0
Rose	1.5 to 2.5	5.5 to 6.0
Spinach	1.8 to 2.3	6.0 to 7.0
Strawberry	1.8 to 2.2	6.0
Sage	1.0 to 1.6	5.5 to 6.5
Tomato	2.0 to 4.0	6.0 to 6.5

**Table 4.1.2** Common hydroponic plants electrical conductivity and pH values.[62]

When it comes to agricultural, crop production is standardized heavily. For example, the USDA uses labels and seals to ensure agricultural products meet requirements in quality. The USDA also sets standards for what pesticide procedures and amounts can be used and allowed in crops. Crops are allowed 5% of pesticides. The USDA also puts regulations on proper labeling of organic products making sure that they are organic. Since our greenhouse will be closed off there will be no need for harmful pesticides making sure our produce is as nice as possible.

#### **4.1.4 Raman Spectroscopy Standards**

The American Society of Testing and Materials has multiple publications outlining standards designated to Raman spectroscopy. When dealing with Raman spectroscopy the resolution is important for finding what shifts are occurring. Standards on calibration Raman band of calcite are outlined giving details on the calibration process. This can help us understand how to test and determine resolution for the spectrometer and confirm its proper calibration.

Standards are also provided for relative intensity correction when it comes to Raman spectrometers by the American Society of Testing and Materials.[62] These outline the intensity correction procedure that help correct with looking at different excitation sources and instruments. This can come in handy allowing us to be able to compare the spectrum of water and the contaminants contained within to the spectrum compared to other instruments.

#### **4.1.5 Solar Power Standards**

The solar panel industry is vast and residential, and standards usually come with such traits. The International Electrotechnical Commission outlines standards on photovoltaic performance. These publications outline testing procedures, conditions, and requirements for testing performance quality of cell modules on a photovoltaic panel. The quality of the cells of a photovoltaic panel are addressed as well with performance requirements under different test conditions and safety concerns. Also, when dealing with solar panels DC voltage is being used which requires more safety precautions to be set in place to prevent harm.

### **4.2 Design Constraints**

“Constraints are limitations on the design, such as available funds, resources, or time.” [28] In the real world these constraints are given to us by either the customer or the implementing organization. When specific constraints are defined, they become a programmatic requirement. [25] In our design there are many different constraints that need to be met and considered. These constraints act as limiting factors in our design that may require us to make changes, or the constraints may serve to influence our design choices to mitigate the concerns posed by the constraints as much as possible.

#### **4.2.1 Solar Power Constraints**

Photovoltaic panels are a great choice to collect solar power without having to deal with fuels. Being able to collect power from the sun comes with many benefits like being able



to keep a system off grid power. Even with its many upsides however, solar energy does come with many constraints. When dealing with solar energy you must have the proper setup to ensure your panels will be able to collect energy as effectively as possible. This requires a lot of room and adjustments. On the larger scale of solar energy are solar farms. These areas take up a lot of room and require a large amount of land. With this limitation on room also we are also limited on how much energy we can collect since we want to keep the solar section on the smaller. Scale. To be able to power every component of the system constantly for 24 hours a week would require much more power than the solar panels can produce. To remedy this fact, we reduced the time that the solar panel must be able to run all of its systems to 8 hours. Solar panel selection also has constraints on the price as well. On average, a solar panel capable of producing 100 watts of power is around 200 dollars. This price quickly adds up for the more required power your system needs.

#### **4.2.2 Economic and Schedule Constraints**

Looking first at the budget, we must maintain a total cost of less than \$4000. There are many different parts needed for our design such as the spectrophotometer (\$1500), greenhouse (\$800), and solar panels (\$500) that alone are estimated to be more than half of our total budget. This constraint limits our part selection ability as we must always look for a less expensive alternative inhibiting us from selecting the potentially best part.

Since this project is to be designed and completed in two semesters per the ABET requirements, it is necessary to consider project scaling and to make sure the design is scaled properly to properly finish the project within the two semesters. With more additions to the design there would be more considerations to take place and more components to test and build. If any part of the system would need to breach the two-semester cutoff, it would lead to major setbacks for the team. Due to this is it important to properly manage the size of the project as well as the schedule to complete all of the different components. Any further additions to the project must be weighed to figure out if the burden would be a necessary and beneficial addition to the project and must also be completed within the time frame.

In terms of schedule, our design must be completed and delivered by the 9<sup>th</sup> week of Senior Design 2, Friday, March 17<sup>th</sup>, 2023. The timeline described in the milestones section clearly lays out what needs to be done and by when. This constraint not only requires us to work timely but we must also be diligent gathering our parts. Recently many parts, especially those involving computer components, are increasingly hard to come by. One example is parts relating to environmental sensors. The lead time for some of these parts is 19 weeks. [26] Lead times are always changing but we must prepare for the worst to meet our deadline. To meet our constraint, we must begin gathering parts before Friday, November 4, 2022, 19 weeks prior to our March 17<sup>th</sup> date.

#### **4.2.3 Social and Ethical Constraints**

There are many social constraints to consider in our design. For starters our design needs to be, for the most part, self-sustaining. There are several resources involved in our systems which will be gradually used over time. In addition, different levels need to be maintained within our systems. To maintain self-sustainability, we must incorporate resource

collection from nearby sources and be able to automatically maintain the levels in the systems. Another social constraint is the usability of our design. Our systems must be accessible from proximity, provide a reliable response, and have a fast response time. To maintain usability our design must incorporate a wireless communication module, as well as other devices which are reliable and can process data quickly.

When seeking to overcome issues of food insecurity and diminished quality of life, there are some ethical constraints which arise. We must be able to produce food, in our case plants, efficiently to combat food insecurity. To increase quality of life we first need to ensure that the set-up of our final product is possible for everyone as our product is intended to be used in a community garden. We must also make sure that the parts selected for our final product are reliable enough to be left unattended for a long time, and easy to be replaced when the time arises.

#### **4.2.4 Health and Safety Constraints**

When dealing with health there is no room for error. Our product will create food for people in the form of plants, which consuming has a direct impact on the health of the individual. This requires us to make sure each aspect of the different systems is safe and reliable. There are many parts in this system which will be in direct contact with nutrients being provided to the plants. The parts we select must be safe without any possibility of contaminating the nutrients. When dealing with water there is always a possibility of contamination. In order to have water that is safe to be used for producing food we must make use of purification. The previously discussed ultraviolet purification will be used in our product to meet this demand.

Since light can disperse and reflect off different optical components and the glassware used in the water spectroscopy, we face a design constraint on making sure the laser excitation source doesn't affect other parts of the system. There are also safety concerns when dealing with lasers that must be considered especially when it comes to wavelength outside of the visible spectrum on light. Dealing with spectroscopy means using an excitation source laser safety must take priority to make sure that no harm can come from the laser. Since the wavelength of the excitation source for the Raman spectrometer is 785 nm extra caution must take place. 785 nm is just out of the range of visible light and whenever dealing with non-visible light caution must take place to ensure that the laser can't cause harm to anyone who is unaware that light is being shined into their eyes and possibly causing damage. To fix this problem we propose an enclosure for the laser system to make sure that no stray beam is capable of ever presenting the risk of possibly causing harm to someone.

Similarly, safety has no shortcuts. When dealing with any system that is supplied with power there is always the possibility of being shocked. When dealing with higher power systems there is even the possibility of death if proper precautions aren't taken place. The main components of the effects of electric shock come from the amount of current flowing through the person and the amount of time it flows through them. Typically, the larger the current the more severe the shock. The following table shows the typical effects of different electrical currents in the human body.

Current	Effect
< 1 mA	Usually not noticeable
1 mA	Tingling sensation
5 mA	A small shock is felt. If the person were to be holding on to the object, they would be able to let go.
6 mA – 25 mA (women)	A painful shock is felt. Muscle control will be lost.
9 mA – 25 mA (men)	A person may be thrown away from the power source if the muscles are excited by the shock. The person will not be able to let go.
50 mA – 150 mA	A person will experience severe pain, respiratory arrest, severe muscle reactions, and he/she could die.
1 A – 4.3 A	The rhythmic pumping action of the heart stops. A person will experience muscular contraction and nerve damage. The person is much more likely to die.
10 A	The person will experience cardiac arrest, have severe burns, and will probably die.

**Table 4.2.1** Comparison of different currents and their effects on the human body. [29]

To alleviate this serious risk, we must make sure that we maintain a low current in all our wirings and systems where we can. If a large current is needed, we must take the necessary steps to keep the public safe. These safety needs may be achieved through the clever placement of electrical components to avoid any potential interactions between the public and the potentially harmful electrical systems. We will have to ensure that we take special care in the design of our housing as well as in the materials we choose to construct the project.

#### **4.2.5 Spectroscopy Constraints**

One of the major constraints applied to our design when considering spectroscopy is that of the price of commercially available spectrometers. Most spectrometers start within more than 10000 dollars which is much higher than what we can provide for this component. The only other option to do spectroscopy is to borrow a spectrometer unit and laser emitter that goes along with that unit. Luckily, we were able to borrow An Ocean Insights spectrometer as well as a 685 nm laser emitter for the spectrometer. This resolves the constraint of budget when dealing with spectroscopy. As we are going to be analyzing water samples in a glass feeding container it is necessary to know the refractive index of the glass in use and the density as well. These factors have a major effect on how light will be dispersed when hitting the glass. Since we don't have all the specifications for the laser excitation source, we don't know how light will be exactly dispersed when used to analyze water samples. We will further take special care to ensure that the spectroscopy system is housed in a manner that will allow it to operate with peak performance and outside of public reach. This way, we will not have to worry about the external factors that may affect the spectroscopic analysis being conducted such as ambient light outdoors.

#### **4.2.6 Filtration Constraints**

When researching the types of water filters that can be used for this system, we determined that there were numerous constraints that exist depending on the types of water filters we choose to employ. With respect to granular activated carbon filters, the major constraint of this filter is the size of the particles the filter can remove from the water. The absolute best GAC filters are only able to filter particles as small as 5 microns, but these GAC filters are far more expensive and less accessible than the GAC filters we would hope to employ in our system. If we were to use reverse osmosis filtration, we would be limited by the size of the pressure tank that is integrated in the system. This tank is one of the defining portions of the reverse osmosis system and acts as a major constraining factor.

Of course, we are most constrained in what can be filtered when we elect to use a UV purifier. On its own, this filtration system can only kill microorganisms and living contaminants. It severely constrains the system by not being able to physically or mechanically remove other dissolved solids or harmful particulates. Furthermore, UV purifiers constrain the system by increasing the overall power consumption used for the filtering process. Given that the filter will have to function in conjunction with the pumps, sensors, and water analysis system, the power the filter needs constrain the frequency with which the filter can be turned on.

The best way to mitigate any constraining factors presented through the use of one filtration process over another is to utilize multiple filtration processes to eliminate some of the constraints. For example, we have elected to utilize UV purification to kill any microorganisms that may threaten or harm our hydroponic system. To eliminate the concern that the purifier will not be capable of removing any physical chemicals, metals, or other particles, we will use a combined system with other filtering methods such as granular activated carbon and activated carbon blocks. Using a combined system in this case will allow us to effectively eliminate the concerns posed by the constraints presented here, and it will also allow us to further operate within the constraints posed in the previous discussions such as the health and safety constraints.

## **5.0 System Designs**

For our project, several different systems need to be designed and incorporated to reach our goals. These designs explain the inner workings of each system, showing our process, and connections that need to be made.

### **5.1 NFT System**

As before, we begin with the NFT system. There will be a total of three NFT systems housed within the greenhouse all sharing the same design and constraints. Depicted in Figure 7.1.1 are two views of our hydroponic system design. It has been stated several times that we are seeking to maximize the amount of space we utilize for the growth of plants to simultaneously maximize the number of plants we are capable of growing. The system depicted above features three levels of growth trays with two trays per level. This allows us to have a total of six growth trays in each plant system with the plants being spaced approximately six inches apart from each other. With a six-inch spacing, each growth tray can accommodate up to nine plants, equating to fifty-four plants per system, or a total of 162 plants in the greenhouse.

Initially, we expected to use a single, wide growth tray per level and offset the plant rows to reduce competition between the roots for nutrients and water. However, this design aspect was abandoned for two reasons. First, we determined that it would be difficult to find an affordable tray that fit the dimensions we were seeking. We quickly found that it was much simpler to find smaller scale rectangular PVC for our growth trays compared to larger rectangular pieces. Second, the use of individual growth trays reduces the competition between roots which also will result in better water flow through the system. An important aspect of NFT systems is that the ends of the plant roots are completely covered by the flowing nutrient solution, and by using two growth trays, this helps to confine the roots to the water pathway on a single axis. In a larger growth tray, a plant would have to compete with three plants at once as opposed to only two plants. An added benefit of two separate trays arises from not having to offset the plant rows, which would have reduced root competition, thereby adding an additional plant per level for a total of nine extra plants.

We opted to include LED light strips in the design of the system as well. Though we did not mention the use of LEDs for the hydroponic system in the goals and objectives, we decided to include it in our expected system design to increase the plants access to light. The use of a three-stage NFT system with two water lines inherently means some of the plants will receive less light than others. Including LEDs above each of the growth trays will ensure that all plants are receiving direct lighting, and it also allows us to program the system to have light up to twenty-four hours a day. This is especially useful in winter months when there is less sunlight per day, making the growth of certain plants possible despite not being in their optimal growth season.

With this design, we can meet our design dimensions of 1.5 feet x 5 feet x 6 feet. It makes an efficient use of vertical space for planting with space to store the nutrients and pH balancers beneath the system for deposition in the system specific reservoir. The LEDs will

maximize the growth potential of the plants, and the plant spacing should allow for the greatest possible number of plants per system with minimal negative effects on the plant growth.



**Figure 5.1.1** Nutrient Film Technique Hydroponic System

## 5.2 Rainwater Collection System

The rainwater collection system is certainly the most robust system in the entire greenhouse. This system features a central reservoir, three system specific sub-reservoirs, a water filtration system, and a Raman Spectrometer for in-line water quality analysis. In all, this system required a large amount of thought on how to connect each water tank together to create the whole reservoir in addition to how to pump the water and nutrient solutions into the NFT systems. An important note about the above depictions of the components in the rainwater system is that they are drawn in a near-scale not in a to-scale manner. This is a concept design using general geometry for a cleaner drawing than the exact system design. For example, the reservoirs will be constructed using standard garbage cans which are either cylindrical or rectangular in nature and not connected along their sides.

The first aspect of the rainwater system was how to channel the rainwater into the reservoirs. To achieve this, all four sides of the greenhouse will have gutters to catch the water with two downspouts at the rear of the housing that will channel into the central reservoir through a screen in the top of containers. When catching rainwater, we wanted to achieve

active and passive collection to maximize the amount of water we can channel into the central reservoir. We define active collection as channeling rainwater using water channels like the gutters surrounding the roof of the greenhouse. On the other hand, we define passive collection as capturing the rain directly in the barrel from the sky without the use of any channels. Therefore, the central reservoir will have a screen lid over the top that will be open to both active and passive collection. This allows us to maximize the rainwater collection area by adding additional collection potential off the roof of the greenhouse. Additionally, the use of a screened entry point to the reservoir acts as a first line of defense against large debris entering the system. This reduces the stress on the water filtration system, improves the overall health of the system, and reduces the maintenance required to remove debris from the reservoirs. Should the central reservoir reach a level near its maximum capacity, each of the three containers has an overflow pipe to expunge excess water from the system. The central reservoir is expected to be capable of holding between 120 and 180 gallons of water depending on the size of the containers we use. Since this reservoir will be used to fill each of the other three, it needs to be the largest to ensure every reservoir can receive extra water as needed.

With the problem of collecting the rainwater solved, we turned our attention to how the water will be distributed within the barrels. Given the scale of the project, we thought it would be unwise to add additional pumps, sensors, and sequencers to balance the water level between the three water containers in the central reservoir. Therefore, we decided to connect each tank by PVC underneath the reservoir. This will ensure each container passively maintains an equal level of water as the other two as they are being filled. Since the left and right water containers will be receiving the water supply, the center container is left to pump the water out of the central reservoir into the filtration system. As a result, the center container features a submersible water pump as well as a water level sensor. The water level sensor will not act as a trigger for any part of the mechanical parts of the overall greenhouse. It will simply function to inform a user of the low water level in the tank. It will also have the additional function of blocking the pump feature to the system specific reservoirs (SSRs) in the event the water level is too low. The submersible pump will be triggered by the water level sensors in each of the three system specific reservoirs (SSRs). When one of these reservoirs are low, it will trigger the system to pump water from the central reservoir into the depleted reservoir.

Before the water is channeled to the SSRs, it passes through a water filtration system. The water filtration system will feature at least two forms of water purification, UV purification and carbon filtering. The water will be channeled from the central reservoir first into the carbon filter to remove any particulates or harmful contaminants. It will then pass through an ultraviolet filter to kill any microorganisms that might exist within the water. This two-stage water filtration method will ensure the water is in the best possible condition for the hydroponic systems. Because the plants grow directly in the water solution provided to them, the quality of the water is of the utmost importance for the growth factors of the plant. The plants will absorb nearly anything directly from the water as the source of their nutrients which necessitates providing the cleanest possible water. As stated previously, the best possible water for hydroponics before adding nutrients is distilled water which is free of all particles and contaminants.

To analyze the quality of the water following its filtration, we have included a Raman spectrometer as an intermediate component between the filter and SSRs. The inclusion of the spectrometer is to allow the user to be informed about the quality of the water in the system. Though the inclusion of the spectrometer is an advanced goal, we felt it would be an important addition to the system to allow the user to know the quality of the water entering the SSRs. The spectrometer would be able to identify concentrations of specific compounds in the water such as arsenic or zinc cyanide which can be harmful to biological organisms. The function of the spectrometer would be to notify the user that the water contains high concentrations of harmful compounds so the user can purge the water supply before it harms the plants. Though it is an advanced system, it is highly precise and will ensure that the potential food supply for community members will be safe for consumption.

Once the water is filtered and analyzed, it will pass through a three-valve inline manifold assembly. The valve manifold will be triggered in a fashion similar to a sprinkler system, only in this case it is triggered by the water level sensors of the SSRs as opposed to being on a set timer. Therefore, the manifold will be connected to our microcontroller to allow the sensors to communicate with it. Using this system design, we will be able to efficiently distribute the water in the central reservoir to the SSRs on an as needed basis to restore specific tank water levels.

The final component of the rainwater collection system is, of course, the system specific reservoirs. These reservoirs will feature a two-container system as well as all the system sensors to act as triggers for the various systems. Figure 7.2.2 depicts the concept design for the SSRs that will be used in all three cases. Each SSR is expected to be able to hold between 80 and 120 gallons of water based on the size of the containers used. As before, we sought to solve the problem of water level equivalence using a pipe connecting both tanks from the bottom. This pipe connection also makes an ideal place to deposit the nutrient solutions and pH balancing solutions into the system. Depositing the solution here will allow them to immediately be distributed to both sides of the reservoir. The filtered water as well as the recycled nutrient solution from the NFT system will be deposited into the left container. Using a wye connector, the filtered water and recycled solution will use the same pipe. This container will also house the EC/TDS sensor and the pH-sensor since this is the location the levels may be put out of balance. These sensors will trigger the dosing pumps in the nutrient and pH system to rebalance the solution for the specific NFT system.

One of the needs of an NFT system is to keep the water fresh, which requires high level of dissolved oxygen in the system. The reservoirs are closed water systems; therefore, they require an air stone to maintain the level of dissolved oxygen in the water. We opted to place this in the left container as well to stimulate circulation of the filtered water, recycled solution, and deposited solution in the left tank. The right tank's circulation is stimulated using a submersible water pump within the container. The intention behind dividing the sensors, pump, and air stone between the two containers is to provide the greatest amount of circulation and analysis of the water over a long-time span. It is worth noting that much of the time, the system will not be triggering the pumps in the central reservoir or the



nutrient and pH system. This means it will establish and maintain its equilibrium over time as opposed to in an instantaneous time window. Thus, as the right container pumps the nutrient solution into the NFT system, it simultaneously draws water from the left container creating a self-correcting system. The last component of the SSR is the water level sensor. This sensor will trigger the central reservoir and valve manifold to pump water into the tank to refill the system.



**Figure 5.2.1** Central reservoir and water filtrations system designs



**Figure 5.2.2** System specific reservoir design

The greenhouse provided the perfect opportunity to channel rainwater into a reservoir, allowing us to collect water from 48 square feet of space using simple gutters and tubing. The rainwater system features a central reservoir, filtration unit, portable in-line Raman spectrometer, solenoid valve manifold, and sub-reservoirs designated for each specific hydroponic structure.

As rainfall occurs, the rain is channeled into a central reservoir comprised of three 45-gallon trash cans connected underground at their base by PVC pipe. This allows the cans to fill and empty at an equal rate so the water is distributed evenly across the three cans. We use a single water level sensor placed low on one of the cans to receive a rough baseline estimate of how much water remains in the central reservoir. We also only use a single pump to pump water from the three cans using this underground connection.

The central reservoir pump is only triggered by the water level sensors of the three subsystem reservoirs. Each sub-reservoir includes two 45-gallon trash cans connected to each other underground at their base, a water level sensor, an EC/TDS sensor, a pH sensor, and a pump. One can acts as the input can which receives water from the central reservoir, doses of nutrient and pH solution from the deposition system, and the recycled water from the NFT system. The other can acts as the sensing and output can which pumps water from

the sub-reservoir to the NFT system and triggers the central reservoir as well as the deposition system. Because one can act as an input and the other acts as an output, it naturally circulates the water between the two cans to distribute the deposited solutions throughout the water system.

When the water level sensor reads low, the system will automatically trigger the solenoid associated with that system as well as the central reservoir pump to pump water from the central reservoir to the specific system. The water pumps from the central reservoir through a 6-stage water filter that features an ultraviolet sterilizing stage. This means the filter will remove major particulates, microorganisms, and micro contaminants before sending the water to the solenoid manifold. Once the sub-reservoir is filled, the EC/TDS and pH sensors will begin reading to balance the nutrient and pH concentration in the water. This triggers the nutrient and pH deposition system to begin pumping solution into the sub-reservoir.

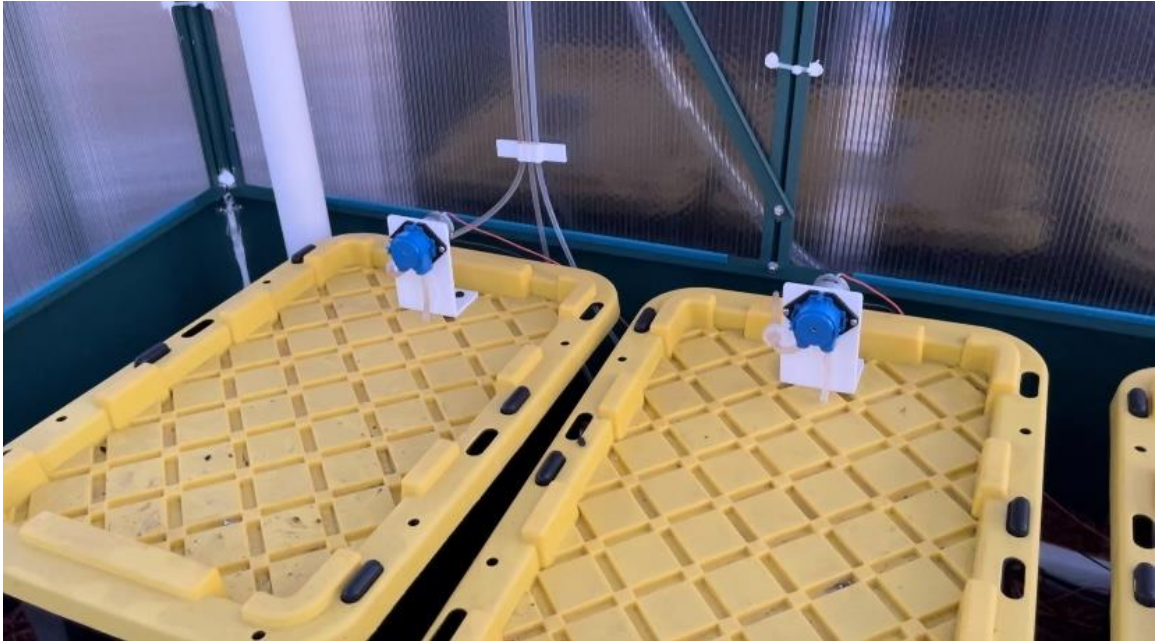
One of the major features of this project is the ability to use a Raman spectrometer to analyze the water content through any of the vinyl tubing in the entire system. This was accomplished by 3-D printing a small housing for the lens assembly that has a slotted sampling port in the center to slide the vinyl tubing into or out of the assembly. This allows a user to insert or remove the Raman spectrometer anywhere vinyl tubing exists in the system. To note, the spectrometer is a non-integral part of the system; it does not have any triggering functions. It is solely to allow a user to inspect the water quality anywhere in the system in the event they may need to make adjustments for system irregularities. This system is powered by a USB cable plugged into a laptop computer, and the analysis is conducted using OceanView, software provided by Ocean Insight. The spectrometer itself is an early model developed at Ocean Insight, and the laser source is a 785 nm wavelength laser that was also produced at the company.

### **5.3 Nutrient and pH Deposition System**

The NFT system would not be capable of growing plants if not for the nutrient system that deposits the nutrient solution into the system specific reservoir. When designing this system, we quickly determined that it would be best to combine the nutrient system and pH balancing system. This build allows us to conserve space about the greenhouse and reduces the amount of piping needed by further separating the system. We will utilize three different peristaltic dosing pumps between the three containers that will send the solutions through a double wye connector to be delivered to the system specific reservoir. Each of the three containers will also use a water level sensor which will notify the user when the solution levels in the specific storage tanks are low. To increase the ease of refilling the containers, we have also included funnel fittings into the design.

The amount of nutrients needed for hydroponics is much smaller than the amount of water necessary for the same hydroponic method. Therefore, we do not need as large of a container for the nutrients as we do for the water. The same is true for the pH balancing solutions. It only takes small amounts of pH-up or pH-down to manipulate the levels of large quantities of water, and as stated previously, the system will remain in equilibrium for large amounts of time before it needs to trigger these pumps. Thus, we do not expect a

user will need to regularly refill these containers due to the low usage over long periods. These containers will be housed in the space underneath the NFT system due to the growing lack of space that will be available along the exterior of the greenhouse. Conveniently, this will also place the containers near the storage compartment for additional solution bottles.



**Figure 5.3.1** Nutrient and pH Down deposition system (Missing pH Up)

Plants would not be able to grow without the proper deposition of nutrients and pH balancers into the water, so an automatic deposition system was implemented to further negate the needs for a person to do it. Each NFT system will have its own deposition system featuring three storage containers. These containers store nutrient solution pH up solution, and pH down solution respectively. Previously, it was mentioned that there are two water sensors in the sub-reservoirs, an EC/TDS and a pH sensor.

These sensors rest vertically on a buoy in the output can of the sub-reservoir to check the electro-conductivity and pH levels of the water after dosing. By measuring these values at the top of the water in the output cannister, we are able to measure the distribution of the levels over time between the two cans due to the natural circulation of the water from the input and output structure of the reservoir. These sensors are set to trigger periodically when the deposition system is not active, and they read the values in intervals during the deposition activity. In this way, the system allows itself to take time to circulate the water before continuing the dosing process. In turn, this increases the amount of time it takes to completely balance the water levels because circulation time must be accounted for by the system. The deposition is accomplished using a peristaltic pump to have finely tuned control over the amount of solution that is put into the reservoirs. A water level sensor is integrated into the nutrient and pH storage containers to notify a user when they are low simply by looking at the control site using the local area network.

This system is also triggered each time the central water reservoir refills one of the sub-reservoirs to ensure the solutions are not diluted by the addition of more water into the system. Each NFT system has its own nutrient and pH deposition system. Every plant exhibits different preferences for pH ranges and nutrient ratios, so this allows a user to be selective about the kind of nutrients and pH solutions that are used in each NFT system.

#### **5.4 Photovoltaic System**

With as many electronics as we plan to include within this greenhouse, we will need to generate and store plenty of power to ensure it is operable under poor conditions. As a core goal, we will power the system using photovoltaic panels, but we also have an advanced goal to build a tilting mechanism for the solar panels as well.

Should we not have the time to develop a tilting mechanism, we will opt to angle the solar panels at approximately thirty degrees above the ground. It is known that the optimal angle for solar panels is between thirty and forty-five degrees and given that we are in the state of Florida, we believe a shallower angle will be better suited for power generation. We receive large amounts of sunlight every day, so without tilting the panel, the panel should face the sun as directly as possible for as long as possible. Therefore, we will place the panels in an east to west orientation with the panels facing the east. This will allow us to achieve our core objective of maximizing the collection efficiency of the PV system. One of the key concerns for our photovoltaic system is the need to place mount the solar panels in a grassy area. This necessitates that we build an anchor point for the panels that will allow them to stay rooted in the face of extreme weather.

The anchor for the panels can be achieved using concrete, wood, gravel, or a combination of the three. The design depicted in Figure 7.4.1 demonstrates what it would look like if we laid a bed of concrete on the ground to anchor to. However, it is also an accurate depiction of how it would look if we used wood as our main panel structure. The primary difference is that we would bury 4x4 wood posts halfway into the ground before constructing the rest of the frame. The wood posts would then act as the anchors for the panels in the ground to resist extreme winds.

If we are able to develop the tilting mechanism for the panels, it would be along a single tilt axis to reduce the complexity of the design. We would either use a solar tracker or we would set it on a standard timer to rotate throughout the day. For the best results, we would want to integrate a solar tracker into the design to ensure that sunlight is hitting the panels directly to maximize the power generation of the panels. Naturally, a rotating system would also require an improved base structure. In our case, we plan to opt for a triangular frame base to increase the overall system stability during rotation as well as during extreme weather conditions.

We will use a two-panel photovoltaic system for power generation using monocrystalline PV panels. Using a two-panel system, we should be able to generate between 200 and 340 watts of power every day. The power will be routed and stored in a 12 V battery that is housed in the greenhouse. One of our stretch goals is to have excess power routed into a second battery which can easily be achieved by connecting a second battery in series or

parallel to the first battery to increase the overall power storage capacity of the system. The main factor that may keep us from achieving this goal is money as it is a nonessential aspect of the greenhouse. The function of this stretch goal is simply to increase the viability of the system under prolonged unfavorable conditions.



**Figure 5.4.1** Photovoltaic system depiction

## 5.5 Greenhouse Design and Layout

Having discussed the placement of each of these systems abstractly, Figure 8.5.1 lays out exactly how we plan to build the greenhouse with each of these systems. This figure is drawn to scale with respect to our current expectations for the size of each of the systems. Under our current expectations, we believe the entire system will be able to be built upon a twelve-by-twelve-foot plot of land.

As depicted and discussed, the gutter channel, drawn in blue, will surround the greenhouse, drawn in black, on all four sides and channel into the central reservoir at the rear of the greenhouse. The downspouts are drawn as blue squares with an x in the gutter line, and the central reservoir is drawn in orange on the left side of the picture. The water filtration system is drawn as a dashed orange square along the gutter channel, signifying that it will be underneath the gutter channel. Each of the system specific reservoirs are drawn in orange along the perimeter of the greenhouse. The top SSR will feed the top NFT system, drawn in green along the top edge of the greenhouse. The bottom left SSR will feed the left NFT system. The bottom right SSR will feed the bottom NFT system drawn in green. The nutrient systems are drawn as pink dashed boxes within the NFT systems, signifying they are placed underneath the hydroponics.

The PV system is not depicted in the top view of the greenhouse; however, we expect to place the solar panels several feet away from the greenhouse. In the figure, this would be above the top edge of the greenhouse and to the right of the top SSR.

The greenhouse door will swing out to not impede access to any of the systems while the door is open. We plan to store extra nutrients, pH balancers, and tools in the rear corner spaces of the greenhouse to be out of the way of the systems. If we are able to pursue the stretch goal of controlling the temperature within the greenhouse, we will place the A/C unit in the corner to the right of the rear NFT system. This is the top left corner in the figure above. Temperature controlling the system is the last component of the entire system to be able to generate the most optimal growth environment for the plants. Controlling the climate within the housing would greatly improve the ability of the greenhouse to grow plants that are out of season. This in turn would expand the list of potential plants this greenhouse would be capable of accommodating.





**Figure 5.5.1** Greenhouse Layout

### **5.6 Control System**

The devices that make up the control system are the power supply, microcontroller, Wi-Fi module, and external device. The microcontroller receives input from sensors in the other systems as well as the Wi-Fi module and provides output to pumps, the purifier and the

wireless communication module. To function correctly, proper hardware must be put into place and connections made, and software must be implemented properly.

### 5.6.1 Hardware and Schematics

Many connections to different components had to be made for proper functioning of our control system. The hardware design of the control system can be seen in the figure below and the connections made will be further described.

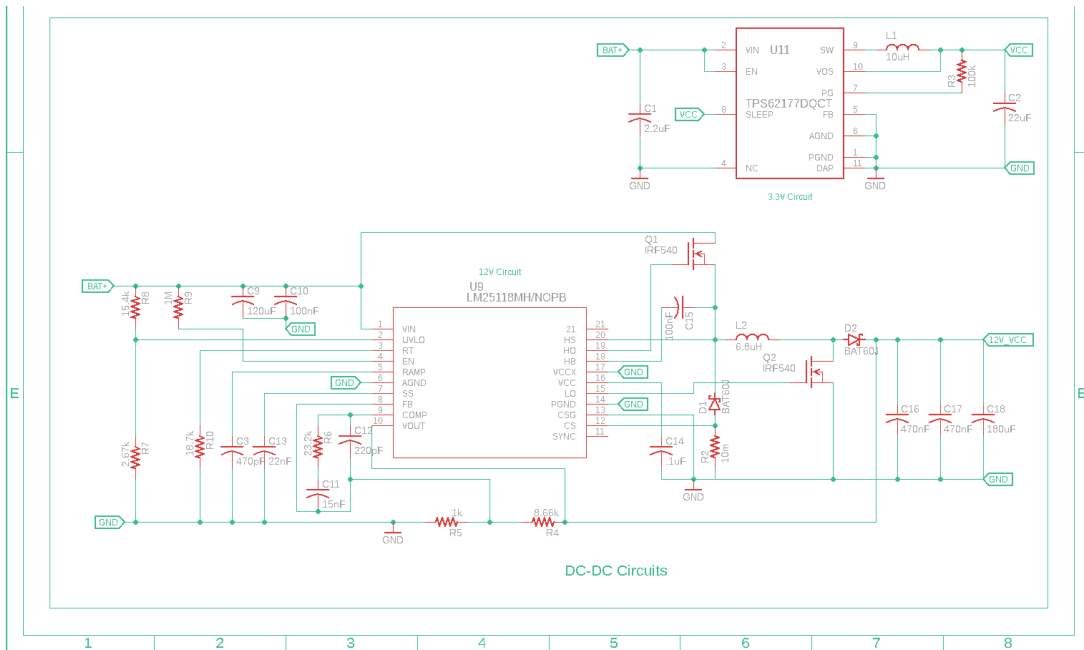


Figure 5.6.1 Initial Schematic diagram of our project.

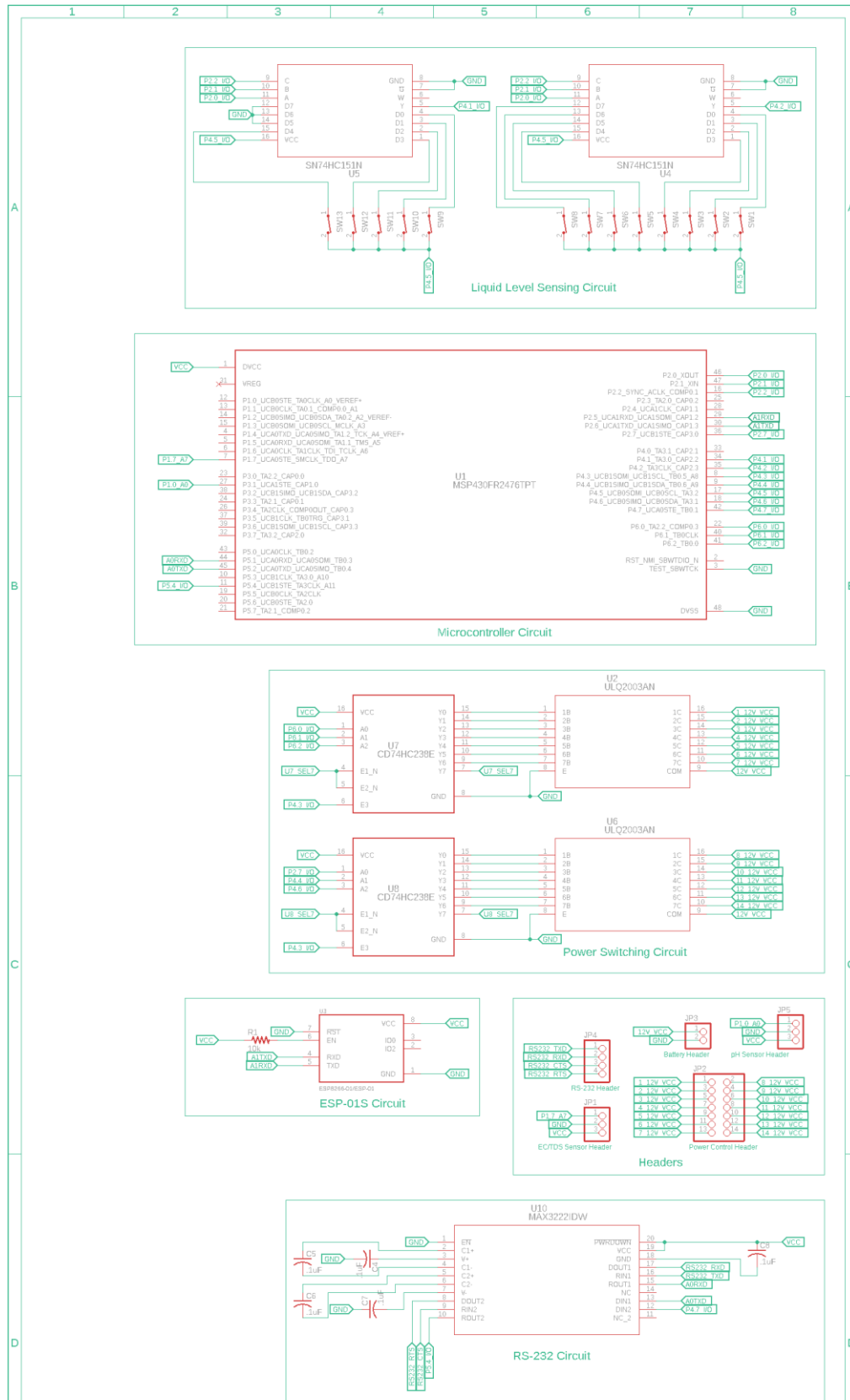


Figure 5.6.2 Initial Schematic diagram of our project.

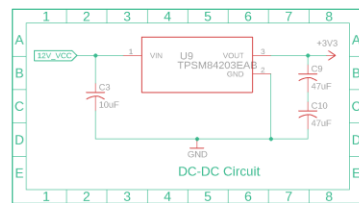
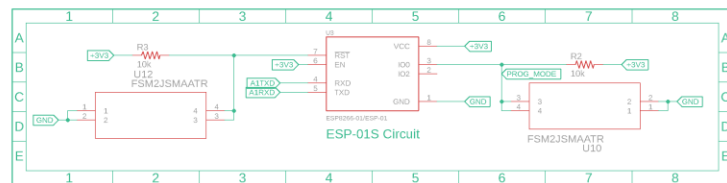
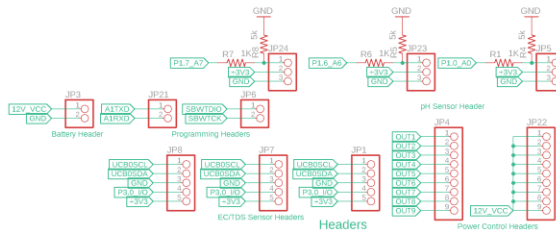
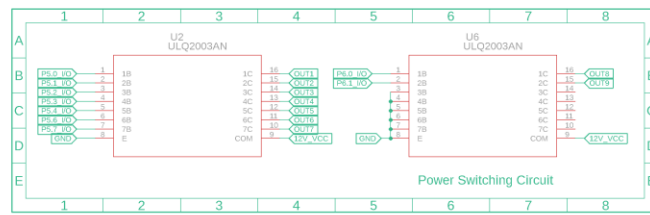
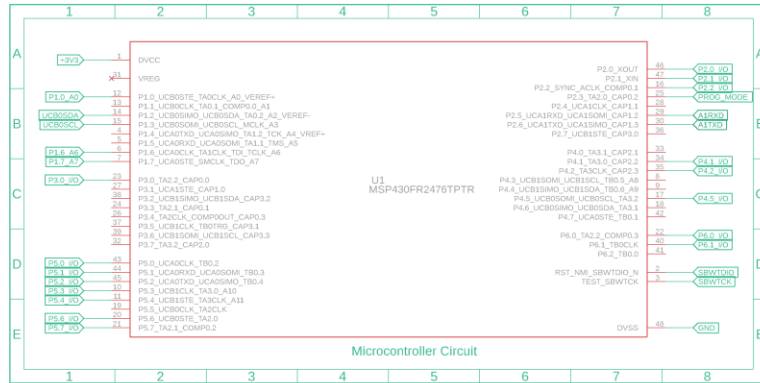
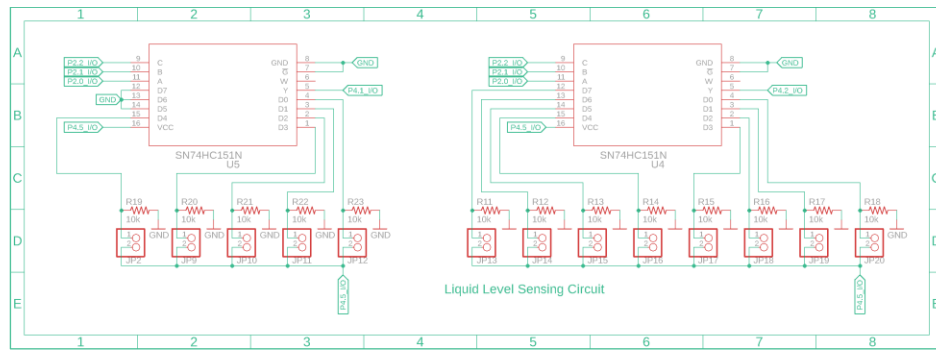


Figure 5.6.3 Final Schematic diagram of our project.

### 5.6.1.1 DC-DC Circuits

The MSP430FR2476, ESP-01S, EC/TDS sensor and pH sensor require 3.3V to operate. The 3.3V circuit uses a buck converter to provide a regulated 3.3V supply from our battery. The pumps, purifiers, and lighting will be run off our 12V supply. This circuit uses a buck boost controller to regulate the voltage coming from our battery to 12V.

### 5.6.1.2 Power Switching Circuit

This circuit provides control of 14, 12V supplies to enable and disable various pumps and purifiers. Making use of decoders allows us to control all the supplies while reducing the number of required GPIO pins. This comes at a cost of not being able to control each supply at the same time. This can be mitigated however because we do not require the loads connected to this circuit to be on at the same time. The outputs of the decoders given the selection lines are as follows.

Inputs				Outputs						
E3	A2	A1	A0	7C	6C	5C	4C	3C	2C	1C
0	X	X	X	0	0	0	0	0	0	0
1	0	0	0	0	0	0	0	0	0	1
1	0	0	1	0	0	0	0	0	1	0
1	0	1	0	0	0	0	0	1	0	0
1	0	1	1	0	0	0	1	0	0	0
1	1	0	0	0	0	1	0	0	0	0
1	1	0	1	0	1	0	0	0	0	0
1	1	1	0	1	0	0	0	0	0	0
1	1	1	1	0	0	0	0	0	0	0

Note: (0) refers to a low voltage and (1) refers to a high voltage. (X) does not matter.

**Table 5.6.1** Truth table for the power switching circuit.

### 5.6.1.3 LP-MSP430FR2476

The MSP430FR2476 microcontroller is the brain of the system and has its hand in every control system component. The microcontroller has many pins with most pins multiplexed to provide additional functionalities. It is important to know which functions these pins can perform when making connections to other components for proper functioning. For our purposes we will discuss the pins and their software programmed functions which are essential for the operation of our project.

Pin Number	Function
1	Provides 3.3V to the MSP430FR2476 and other components.
7	ADC. Analog input A7
8	I/O. Enables (1) / disables (0) decoders.
9	I/O. Decoder U8 selection line 1.
11	I/O. Clear to send (CTS) signal from RS-232 receiver.
16	I/O. Multiplexer U4 and U5 selection line 2.
17	I/O. enable (1) / disable (0) water level sensors.
18	I/O. Decoder U8 selection line 2.
22	I/O. Decoder U7 selection line 0.
27	ADC. Analog input A0
29	UCA1RXD. eUSCI_A1 receive data for UART communication with ESP-01S.
30	UCA1TXD. eUSCI_A1 transmit data for UART communication with ESP-01S.
34	I/O. Multiplexer U5 output.
35	I/O. Multiplexer U4 output.
36	I/O. Decoder U8 selection line 0.
40	I/O. Decoder U7 selection line 1.
41	I/O. Decoder U7 selection line 2.
42	I/O. Ready to send (RTS) signal to RS-232 receiver.
44	UCA0RXD. eUSCI_A1 receive data for UART communication with RS-232 receiver.
45	UCA0TXD. eUSCI_A1 transmit data for UART communication with RS-232 receiver.
46	Multiplexer U4 and U5 selection line 0.
47	Multiplexer U4 and U5 selection line 1.
48	Ground.

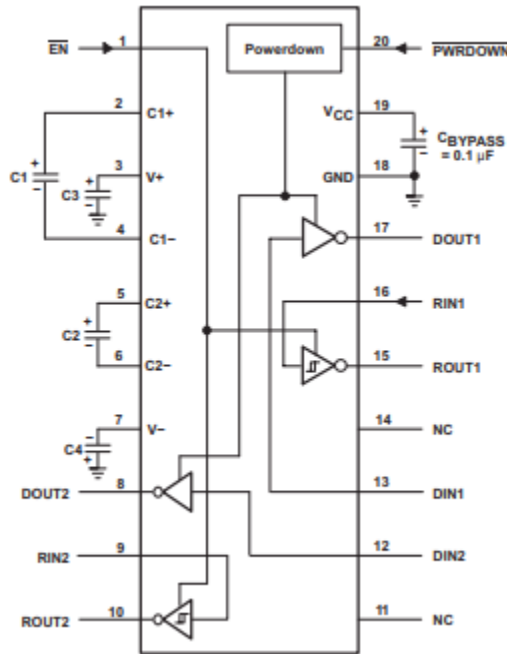
**Table 5.6.2** Description of pins used on the LP-MSP430FR2476 for our design.

#### 5.6.1.4 ESP-01S

The ESP-01S Wi-Fi module communicates with the microcontroller using UART communication. As seen in the research section UART requires only two connections between devices. Pin 5 of the ESP-01s is the UART TXD transmit data. This pin is connected to pin 29 of the LP-MSP430FR2476 UART RXD. Pin 4 of the ESP-01S is the UART RXD receive data. This pin must be connected to Pin 30 of the LP-MSP430FR2476 UART TXD. Making these two connections enables the device for UART communication. Three additional connections must be made for the module to function correctly. Pin 1 connects the module to ground. Pin 4 is the chip select pin. This signal must remain high for the ESP-01S to function and is therefore provided a signal from the 3.3V supply. Pin 8 is the supply pin for the ESP-01S. This module requires 3.3V to operate and is therefore connected to our 3.3V supply. The ESP-01S uses radio waves to send and receive data from the user's device.

### 5.6.1.5 RS-232 Circuit

To convert our TIA-232 (RS-232) serial port from the spectrometer to signals suitable for 3.3V logic circuits we must make use of the MAX3222. The datasheet for the MAX3222 provides connections for a typical application as well as some of the internals of the device.



**Figure 5.6.3** Typical application of the MAX3222. [48]

Much of the following information comes from the datasheet SLLS480H. The recommended voltage supply is 3.3V or 5V. This voltage determines the charge pump capacitor values recommended for design. These capacitors are placed between pins 2 and 4, C1+ and C1- respectively, pins 5 and 6, C2+ and C2- respectively, pin 7, V- and the LP-MSP430FR2476 ground pin 20, pin 18 and 19, VCC and GND. Pin 19 of the MAX3222 is connected to the 3.3V and from this value we are given that all our capacitor values should be 0.1 μF. We are also told that pin 20, PWRDOWN, will set the component in the power-down mode when a low signal is provided. Power-down mode will turn off the drivers, signified by the letter “D”. With this in mind pin 20 is connected to the 3.3V power supply so that it remains on while the microcontroller is in operation. Pin 1, EN, has similar functionality to pin 20 in that it has control of the device. This pin will turn off the receivers, signified by the letter “R” when a high signal is on the line. For our needs the MAX3222 will remain on while the system is in operation and is therefore connected to the ground, pin 20 of LP-MSP430FR2476.

The remaining connections to the MAX3222 from the microcontroller are all signals that require 3.3V to RS-232 conversion for use with spectrometer. Pin 39, UART RXD, of the LP-MSP430FR2476 is connected to pin 15 of the MAX3222. Pin 40, UART TXD, of the LP-MSP430FR2476 is connected to pin 13 of the MAX3222. Pin 34, GPIO RTS, of the LP-MSP430FR2476 is connected to pin 12 of the MAX3222. Pin 35, GPIO CTS, of the LP-MSP430FR2476 is connected to pin 10 of the MAX3222. With these connections in place the microcontroller is now able to use RS-232. The remaining connections are from

the spectrometer to the MAX3222. Pin 8, RS-232 driver output 2, of the MAX3222 is connected to pin 27 of the spectrometer. Pin 9, RS-232 receiver input 2, of the MAX3222 is connected to pin 24 of the spectrometer. Pin 17, RS-232 driver output 1, of the MAX3222 is connected to pin 2 of the spectrometer. Pin 16, RS-232 receiver input 1, of the MAX3222 is connected to pin 1 of the spectrometer. With all these connections in place communication with the spectrometer can occur.

#### **5.6.1.6 Liquid Level Sensing Circuit**

The liquid level sensing circuit provides us with information about the liquid levels of each reservoir using very little power. This circuit also makes use of multiplexers to once again conserve GPIO pins. The same GPIO pins are connected to the selection lines of each multiplexer allowing us to read 13 liquid levels using the same 3 selection lines. The connections made to the selection lines of each multiplexer to the microcontroller are pin 11 to pin 46, pin 10 to pin 47, and pin 9 to pin 16 respectively. In total there are 6 pins required from the microcontroller to this circuit. Two of these pins come from the outputs of each multiplexer. These connections from the multiplexer to the microcontroller are pin 5 of multiplexer U5 to pin 34, and pin 5 of multiplexer U4 to pin 35 respectively. The remaining line is an enable line that forces the outputs of each multiplexer to be low when the enable line is low. This line connected to pin 17 of the microcontroller and to one side of each switch within the circuit.

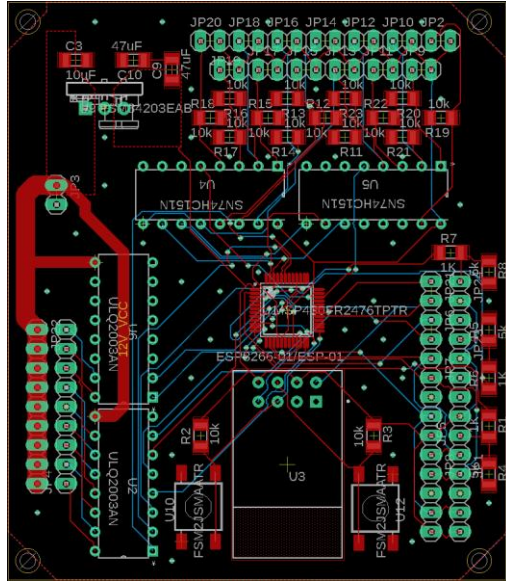
#### **5.6.1.7 Headers**

Several headers were needed for connecting peripherals to the microcontroller and its circuits. These headers include a 4-pin for connecting the spectrometer to the RS-232 circuit, a 20-pin for connecting all the 12V external loads such as pumps, a 3 pin for the EC/TDS sensor, and a 2 pin for the battery 12V input connection to the DC-DC circuit.

#### **5.6.1.8 PCB**

After taking our schematics into consideration, the PCB below was designed with all the parts necessary for greenhouse operation. Many different aspects were taken into consideration when designing this PCB. Some considerations included noise reduction using vias, wire trace width for given loads, and spacing of circuit elements.

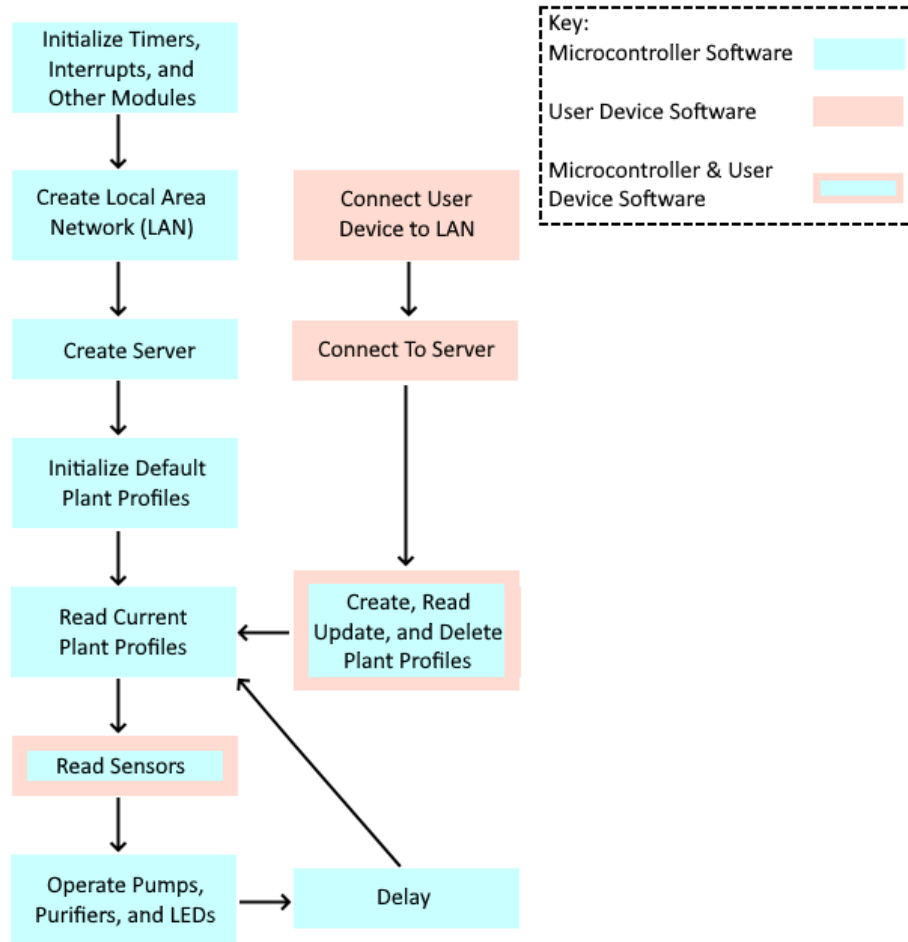




**Figure 5.6.4** Image of our final PCB

### 5.6.2 Software

With the proper hardware connections in place, we move on to our software design. Software is needed in our control system to tell our microcontroller how to control all its peripherals. We must also implement software on the user's device that enables communication with our Wi-Fi module, and in turn our microcontroller. Below is a diagram laying out our software implementation.



**Figure 5.6.5** Block diagram software implementation of our project.

In our design, the microcontroller has numerous sensors and peripherals to monitor, as well as pumps, purifiers, and peripherals to control. For our microcontrollers to do all these tasks, software must be meticulously designed and tested to provide our systems with proper control. Sensors that need to be monitored include the float switches, the EC/TDS sensor (S-EC-01), the pH sensor and the spectrometer. These provide essential information about the water levels of our hydroponic system. Additionally, float switches provide data that lets us know when we need to refill our nutrients. We need to be able to communicate this data not only to our microcontroller, but the outside world as well using our ESP-01S UART communication. Components that need to be controlled include all the pumps, the LED array, and the spectrometer. The remainder of this section discusses the MSP430FR2476 software needed to operate our greenhouse.

### 5.6.2.1 Digital I/O

Software is used to configure our ports and pins to allow them to function correctly. For reference, we look to the MSP430FR4xx and MSP430FR2xx family User's Guide. Beginning with I/O pins, direction registers, PxDIR, are 8-bit registers, with each bit used to select the direction of the corresponding pin. Setting the bit to 0 sets the port pin in the input direction. Setting the bit to 1 sets the port pin in the output direction. It is important

to note that a pin set as input can only be read whereas a pin set to output can be both read and written to. Input Registers PxIN are 8-bit registers with each bit reflecting the pin value of the signal on the I/O line. If the bit is equal to 0 the input is low, if the bit is equal to 1 the input is high. Output registers PxOUT are 8-bit registers with each bit reflecting the value set on the corresponding output pin. The bit values follow those values of PxIN; 0 is equal to low, 1 is equal to high. As mentioned previously the MSP430FR2476 has many peripherals multiplexed to each pin. Each pin requires two bits to select the pin functions. The function select registers PxSELO and PxSEL1 are both 8-bit registers with bits corresponding to each pin. The table below shows the pin function given the selection lines.

PxSEL1	PxSELO	Function
0	0	General purpose I/O is selected
0	1	Primary module function is selected
1	0	Secondary module function is selected
1	1	Tertiary module function is selected

**Table 5.6.3** Function Selection for MSP430FR2476. [55]

Many pins have interrupt capability configured with registers PxIFG, PxIE, and PxIES. Each PxIFG bit is the interrupt flag for its I/O pin. When the selected signal edge happens at the pin, the flag is set. These flags call for an interrupt when their corresponding port interrupt enable, PxIE, and global interrupt enable, GIE, bit are set. PxIES is the interrupt edge select register, selecting the interrupt edge for its corresponding I/O pin. When the bit is equal to 0 the PxIFG flag is set on a low-to-high transition. When the bit is equal to the PxIFG flag is set on a high-to-high transition.

### 5.6.2.2 Timers

The MSP430FR2476 has two timer modules, Timer\_A and Timer\_B. These timers feature 16-bit counter registers TAxR and TBxR which increment or decrement on each rising edge clock signal depending on the mode of operation set. It is important to note that TAxR and TBxR can be read or written. The timer clock will be generated from clocks ACLK or SMCLK. Clock source is selected with the TASSEL bits of the timer register and may be used directly or further divided by 2, 4, or 8 bits to reduce the clock frequency. This is done using the ID bits of the timer register. The TAIDEX bits of the timer register allow us to further divide the clock source by 2, 3, 4, 5, 6, 7, or 8. To clear the timers configuration and counter, TACLK is set high. This bit is automatically reset. These timers include four selectable modes: stop, up, continuous, and up/down selected with the MC bits. Each timer also has 7 capture/compare blocks, TAxCCRn, used to generate time intervals. TAxCCR0 and TAxIV are two interrupt vectors associated with these timers. For the purposes of our project, we will utilize timers for several tasks. When adding nutrients to our reservoirs we need to set a certain amount of time for our pumps to remain active to supply our reservoirs with accurate nutrient supplies. We will also use timers to provide delays to components before setting inputs, before reading outputs to ensure the values have stabilized.

### 5.6.2.3 ADC

“The ADC converts an analog input to its 10-bit or 12-bit digital representation and stores the result in the conversion register ADCMEM0.” [55] Two voltage levels are available

for us to program, VR+ and VR-, allowing us to define the upper and lower limits of the ADC. The output is its maximum value when the input is greater than or equal to VR+. The output is zero when the input is less than or equal to VR-. The following formula shows us how the digital value is calculated for both 10-bit and 12-bit ADCs.

$$\text{10-bit: } N_{\text{adc}} = 1024 \times \frac{V_{\text{in}} - V_{\text{r-}}}{V_{\text{r+}} - V_{\text{r-}}} \quad \text{and,} \quad \text{12-bit: } N_{\text{adc}} = 4096 \times \frac{V_{\text{in}} - V_{\text{r-}}}{V_{\text{r+}} - V_{\text{r-}}}$$

**Figure 5.6.6** Formula for resulting digital value given an input voltage and two reference values. [55]

ADC also requires a clock for conversion. ADCCLK is used as this clock and is selected using the ADCSELx bits. This clock can use clocks SMCLK, ACLK and MODCLK. Clock divider bits ADCDIVx and ADCPDIV allow us to further divide the clock from 1 to 512. ADC has six possible sources of interrupts. In our project we will make use of ADC for EC/TDS measurement as well as pH measurement.

#### 5.6.2.4 UART

The enhanced universal serial communication interface A (eUSCI\_A) supports two modes of serial communication: UART, and SPI. We will be working with UART which requires two pins, UCAxRXD and UCAxTXD. As a side note we have two additional pins when dealing with the RS-232 circuit which also requires UART communication. The RTS pin and the CTS pin. Both pins provide flow to the communication but are not completely necessary. The MSP430FR2476 has two eUSCI\_A modules denoted eUSCI\_A0 and eUSCI\_A1. To select UART communication as the mode the UCSYNC bit is cleared. To use UART a baud rate needs to be established to determine the “rate at which the number of signal elements or changes to the signal occurs per second when it passes through a transmission medium.” [56] This rate must be the same on both communicating devices. eUSCI\_A can interrupt on either a send or receive operation. UART communication will be used in our design for communicating with the Wi-Fi module and Spectrometer.

#### 5.6.2.5 Liquid Level Sensing

For liquid level sensing we are making use of multiplexers and in turn need to cycle through the liquid level float switches to check whether the liquid levels are below the specified level. To perform this operation, we loop through each possibility of selection line inputs, checking the outputs of the two multiplexers and storing their values into a global variable. When a high value is read at either output it is stating that the liquid level is not low. When a low value is read at either output it is determined that the liquid level is low, and attention is needed soon. This circuit can be turned on and off so we must make sure to enable it before performing attempting to read their levels. This pin is denoted P4.5 on the schematics

#### 5.6.2.6 Power Switching Control

To control power to the different 12V devices we make use of a decoder connected to a relay allowing us to minimize the number of GPIO pins necessary from the microcontroller. This comes at a cost of requiring additional software to implement the necessary functionality. In our design we utilize two decoders allowing us to control 14 devices in total, 2, 12V devices at the same time, coming from the relay. Each decoder utilizes 3

selection lines allowing up to 8 different selections. Limited by our relay, we utilize only the first 7 to control our 12V outputs. When a nutrient pump is the device receiving the 12V output, power controlled to this device will be determined by a set time.

#### **5.6.2.7 ESP-01S**

The ESP-01S communicates with our microcontroller using UART communication. With this communication the microcontroller can send commands to the ESP-01S and receive a response. This response can come directly from the ESP-01S or passed through the ESP-01S from the user's device. The ESP-01S makes use of AT commands commonly used to control MODEMs. These commands allow us to control all the operations of the ESP-01S.

### **5.6.3 Testing**

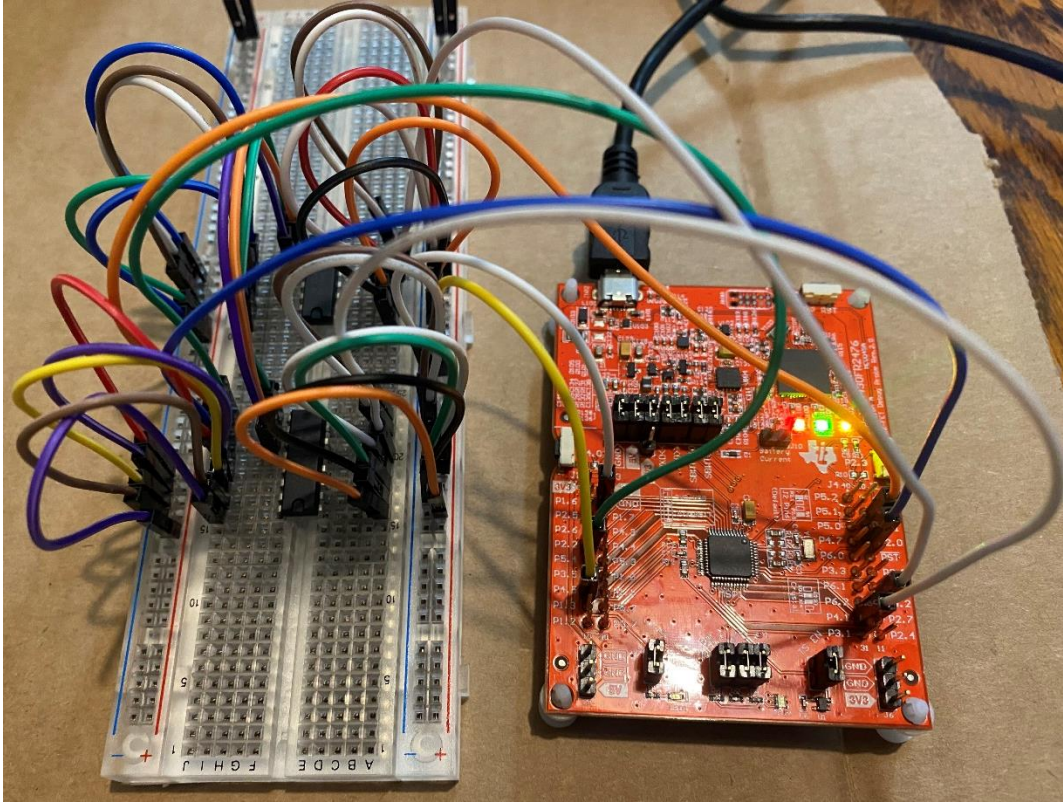
This section discusses the tests performed given the hardware and software implementation. All the circuits need to be tested to make sure our project functions correctly. To perform testing, we need to set up a testing environment. This environment consists of a breadboard, the LP-MSP430FR2476, and each of the circuits. From here we must program our microcontroller to perform all the functions required, test these functions, and make sure our outputs are as expected. As each circuit operates independently of one another we can prototype and test one circuit at a time.

#### **5.6.3.1 DC-DC Supply**

For our control system to function at all we must ensure that our power supplies are sufficient in providing power to all our components. For our system we have both a 12V and a 3.3V power supply. From our 12V supply we will provide power to our power control circuit as well as the lighting and purifiers. The power control circuit requires up to 160mA due to the potential for 2 pumps in this circuit to be active at any given time requiring 80mA each. The lighting and purifiers require the most power. The lighting for the plants will require 2A, while the purifier will require 3A. The total current drawn from the 12V supply is 5A, requiring 60W. The 3.3V power supply will be used to provide power to our microcontroller and Wi-Fi module. The microcontroller will draw a maximum of 75mA while the Wi-Fi module will draw 300mA. The 3.3V supply will provide up to 375mA or 1.2375W of power to the components. In total the DC-DC supplies will provide 61.2375W of power. Parts selected to generate these sources can provide the necessary output voltages and currents for our components to function properly.

#### **5.6.3.2 Liquid Level Sensing**

To perform our liquid level sensing tests, we begin by creating the circuit in a test environment. The image below is the setup of our liquid level sensing circuit connected to our microcontroller. The connections follow those seen in the schematics.



**Figure 5.6.7** Liquid level sensing testing environment.

In this setup the switches are replaced with wires connected to either ground acting as the liquid level low (0) or connected to a 3.3V pin acting as the liquid level high (1). With the software mentioned previously implemented on the microcontroller we are now able to begin testing. We must check different configurations of switches connected to ground and 3.3V to make sure our circuit is functioning correctly. Three tests are given below to verify our implementation. Code Composer Studio will be used to assist us in our programming and debugging.

Case	Debugger Output
All switches are connected to 3.3V	[0b11111111,0b11111111]
All switches are connected to ground	[0b00000000,0b00000000]
Switches are connected randomly to either ground or 3.3V.	[0b0100000, 0b01001000]

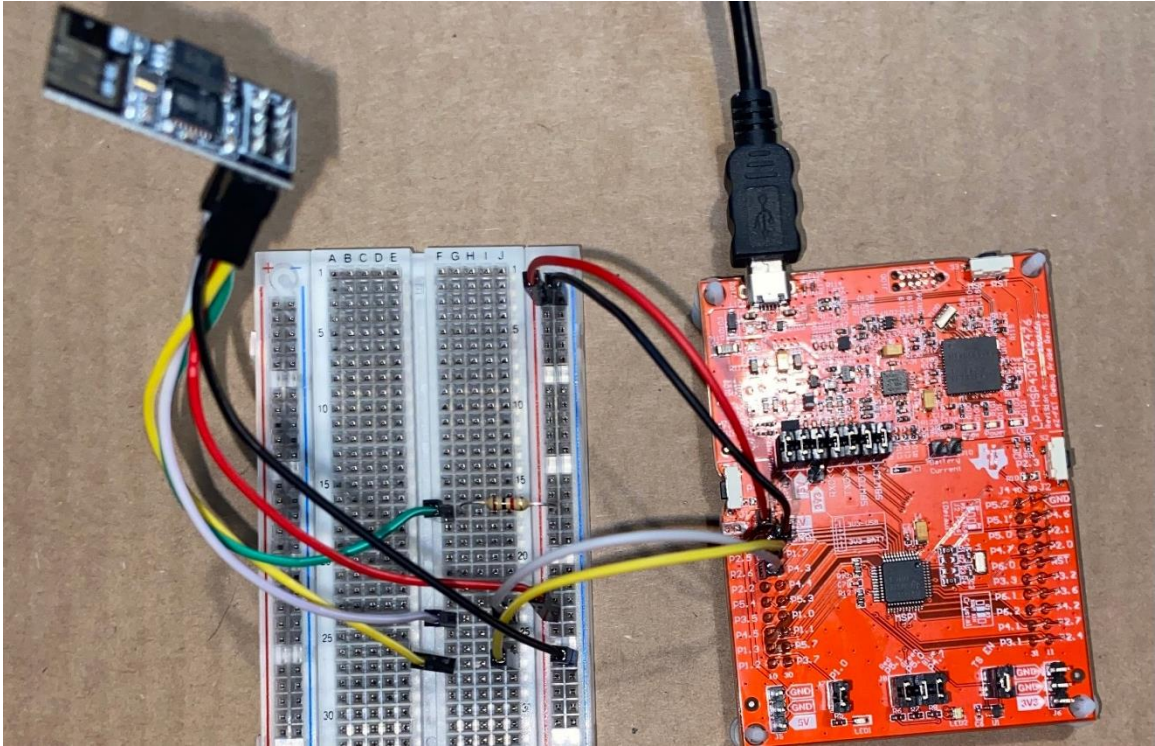
**Table 5.6.4** Three test cases used to verify our outputs given the switch states.

In each case when the switch is connected to 3.3V it will be read as high or liquid level high and when the switch is connected to ground it will be read as low or liquid level low.

### 5.6.3.3 User Device Communication Initial

For communication with the user device, we must create a test environment with our ESP-01S, microcontroller and user device. TCP/IP will be used by the ESP-01S so it is imperative that we design software on the user's device that supports this. With proper

hardware and software in place we can begin testing. Below is the environment used for our testing.



**Figure 5.6.8** User device communication testing environment.

Our testing consisted of making sure we could send and receive messages to and from our user device and microcontroller. Below is an example of the user's device communicating with the microcontroller via the user interface. Socket programming in python was used to establish a TCP connection between the ESP-01S and the user's device.

```

kbuntu@DESKTOP-R2QC3EP: ~/Python/SD1
Control Interface V1.0
Waiting for connection...
Connection established!

Current Plant Profile: Lettuce
  Plant stage: Aging
  Nutrition ratio:
    - Nitrogen: 5%
    - Phosphorus: 18%
    - Potassium: 20%

Current TDS level: 1200 PPM
Current pH: 7.1
Current liquid levels:
  Reservoir 0: LOW   Reservoir 1: GOOD
  Reservoir 2: LOW   Reservoir 3: GOOD
  Reservoir 4: GOOD  Reservoir 5: GOOD
  Reservoir 6: GOOD  Reservoir 7: LOW
  Reservoir 8: GOOD  Reservoir 9: GOOD
  Reservoir 10: GOOD Reservoir 11: GOOD
  Reservoir 12: GOOD Reservoir 13: GOOD
  Reservoir 14: GOOD Reservoir 15: GOOD

Enter a command. Type 'help' for a list of commands.

```

**Figure 5.6.9** Example of the initial user interface on the user’s device.

Commands are sent from our user’s device will request information such as sensor data and status of profiles and external peripherals. These commands can also be used to set plant profiles. The microcontroller is tasked with translating these messages to provide the desired output. The programmed commands expected are as follows.

Command	Response
“SPP=<param1>”	Sets the current plant profile for the system. <param1> is a number, 1-16, denoting the id of user configured plant profiles. If param1 is empty or the plant profile has not been created the response will be the current plant profile.
“LPP=<param1>”	Lists details about the plant profiles. <param1> is the id of the plant profile, 1-16. If it is empty, out of range, or does not exist, all the possible plant profiles will be listed.
“CPP=<param1>, <param2>”	Creates a new empty plant profile. <param1> denotes the id of the profile, <param2> denotes the string identifier associated with the profile.
“EPP=<param1>, <param2>, <param3>, <param4>, <param5>”	Edits the plant profile selected by <param1> the plant profile id, <param2> is the plant growth stage, <param3> is the nitrogen ratio, <param4> is the phosphorus ratio, and <param5> is the potassium ratio
“DPP=<param1>”	Deletes the plant profile selected by <param1> the plant profile id.
“RS”	Reads all the sensors and displays their current data.

**Table 5.6.5** List of commands and responses sent from the user’s device.



### 5.6.3.4 User Device Communication Final

Over TCP/IP we used HTTP to communicate website to date to the user's device. The website is our user interface, and it is served over Wi-Fi providing compatibility for most user devices. The languages used for this website include JavaScript, HTML, CSS, and XML.

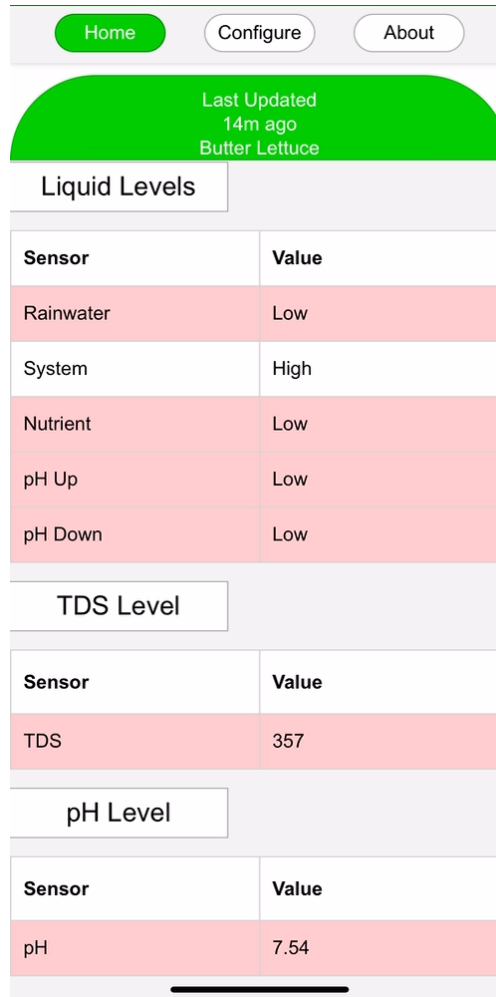


Figure 5.6.10 Final user interface on the user's device.

### 5.6.3.4 ADC

Analog to digital conversion takes an analog input in the form of a voltage and converts it into the corresponding digital signal. As seen in the software section we have formulas for calculating the digital signal based on an analog signal. Because our microcontroller makes use of a 12-bit ADC the formula we will be using is shown below.

$$\text{12-bit: } N_{\text{ADC}} = 4096 \times \frac{V_{\text{in}} - V_{\text{R-}}}{V_{\text{R+}} - V_{\text{R-}}}$$

Figure 5.6.11 ADC formula for 12-bit conversion on the MSP430FR2476.

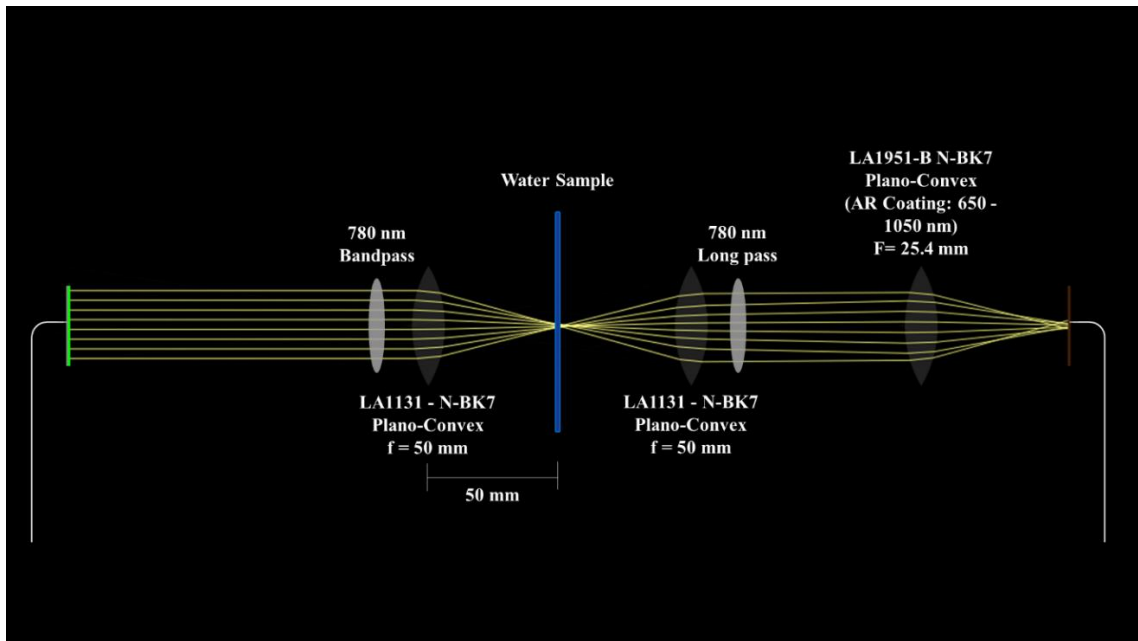
For testing purposes, we will apply three test voltages to the ADC pin of the MSP430FR2476 to verify the results of our conversion. Variables VR+ and VR- are supplied by the microcontroller and are set to 2.5V and 0V respectively. When the input voltage is at or above the 2.5 reference the output is expected to be zero. When the input voltage is 0 the expected output is expected to be full, or -4096.

## 5.7 Optical System

When performing spectroscopy of a sample to get the most beneficial reading considerations have to be put in place to be able to have a functioning and accurate reading. This involve selecting proper lenses as well as filters and coatings to be able to remove unwanted light with as little optical loss as possible.

### 5.7.1 Water Sampling System.

To be able to properly examine and analyze the water sample using Raman spectroscopy a lens system had to be put in place to properly guide the rays from the system through the sample and back finally to the spectrometer. To be able to have as little outside interference as possible a dark shroud is to be placed around the water analysis system in order to reduce the chance or erroneous reading due to outside interference. The optical setup also has to be properly adjusted in order to account for the fact that the water that will be sampled is moving in the system. One other considered approach to be able to perform spectroscopy through moving water was the use of a Raman probe. To be able to use a probing system the spectrometer must be able to allow for such a thing which our system does not. Because of us not being able to use a probed setup our own sampling system must be constructed to constantly measure the spectrum of the moving water.



**Figure 5.7.1** Optical setup for spectroscopy analysis.

As seen in figure 8.7.1 many different lenses and going to be used to run the emitter sources light through the sample and spectrometer. This makes use of many different filters and lenses including that of AR coated lenses. To focus the light through the water sample we are going to be using LA1131 - N-BK7 Plano-Convex lenses with a focal length of 50 mm. We also decided to use LA1951-B N-BK7 Plano-Convex AR coated lenses with a focal length of 25.4 mm in our optical design despite a slightly higher cost since it can help improve transmission, which is especially important when it comes to low light applications. AR coatings also are effective at preventing the undesirable effects that can occur especially in a system with many different optical components like image ghosting. 780nm bandpass filters as well as 780nm long pass filters are going to be put in place to remove unwanted wavelengths from reaching the SMA fiber leading to the spectrometer. This is a step to ensure that unwanted light is removed from the system. Plano-Convex lenses are also to be used to focus the light through the sample and then collimate the light back.

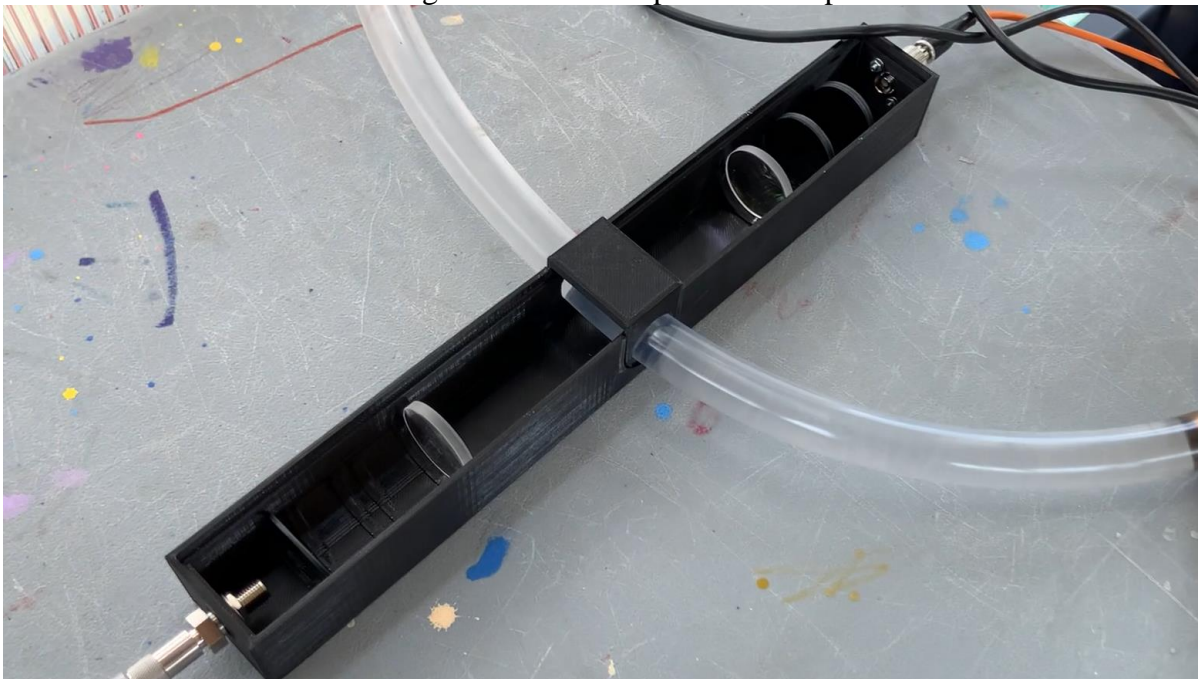
### **5.7.2 Lens System Testing**

To confirm the theoretical optical setup for performing spectroscopy through water some preliminary tests were performed to confirm the legitimacy of the optical system. These tests were performed without the use of our Raman spectrometer since we did not have the correct Raman spectrometer at the time. Since we were not going to be using Raman spectroscopy a different emitter source was used to create a wavelength that the testing spectrometer would be able to accept. To do this we used a white light source emitter to provide light through the sample. This white light was first sent through a microscope. The microscope selected to be used for initial testing was a 20x objective lens. After the light was sent through an objective lens it was then sent through a 700 nm bandpass filter to remove the unwanted bandwidth that comes with using a white light source. By using a bandpass filter, we were able to get 700 nm light passing through the filter while not passing the unwanted wavelength of the white light source. An iris was placed in front of the bandpass filter to remove unwanted light due to mismatched numerical apertures. Both components were placed on top of two linear translation stages in order to properly guide the light from the source to the rest of the system. Following our iris and bandpass filter on the stage was a V-coated lens with an effective focal length of 40 mm. This lens was to act to collimate the light going through the bandpass filter which was acting as a point source of diverging light. After we collimated our light, it was then sent through a 50 mm Plano-Convex lens which focused the light down through the water and then to the next Plano-Convex lens to re-collimate the light to be detected through our spectrometer. The water sample was placed onto a rotational stage to be able to adjust the sample onto so that the light properly focused and passed through the sample.

After re-collimating the light, it was directed into a SMA fiber which was attached to a StellarNet SpectraWiz spectroscope. Such a spectrometer would not suffice for the actual design however for testing due to time limitations initial testing was done with it. A spectrum is visible which was the spectrum of light obtained through the water. When looking at the spectrum we observe a very sharp peak at 700.09 nm. When compared to that observed through an empty sample the wavelength was shifted upwards when passed

through the water. This information is good to know however more clear and useful results would have to be performed using a proper Raman spectrometer.

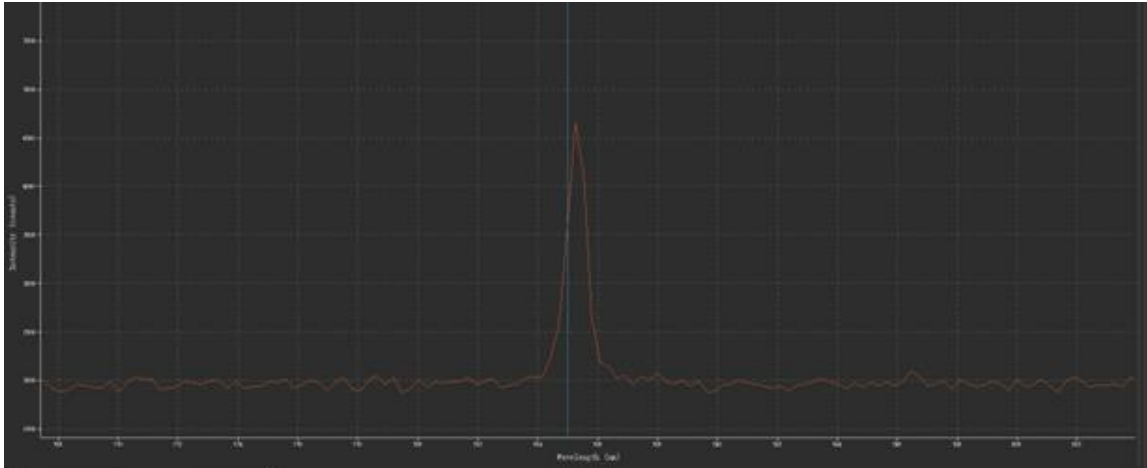
After performing the initial spectrum lens tests we proceeded to create our final version of the lens setup. For our system we used Raman spectroscopy to analyze the water running through the system. There are two techniques used in Raman spectroscopy, being stokes and anti-stokes Raman spectroscopy. For our system we used Stokes Raman spectroscopy. When looking at Stokes Raman spectroscopy photons from the excitation source collide with molecules which result in some of the energy from the photons transferring to the molecule. This loss in expected energy can be measured which results in seeing a wavelength shift, known as a Stokes shift. When performing spectrometry of a sample to get the most beneficial reading a proper optical setup must be put in place to be able to have accurate reading. This involves selecting proper lenses as well as filters and coatings to be able to remove unwanted light with as little optical loss as possible.



**Figure 5.7.2** Final optical setup for spectroscopy analysis through a water sample.

To translate our lens design into a physical system, initially we placed our lenses and filters on an optical table attached to lens posts and translation stages to further align our system to optimize the optical system. After performing these initial optical setups for our system, we later translated the system to a much cleaner 3D printed housing for our lenses and filter to be placed in. This not only made our system much more compact but also completely portable. Originally, we used a long pass and bandpass filter to properly pass our 785nm light though the system to allow for background light to be properly filtered out. After shifting our optical system into the 3D printed housing these filters became obsolete since the system was completely isolated from outside light sources. These filters were substituted with neutral density filters to reduce the intensity of our laser module. The 3D print was comprised of a black tube with slots for out lenses to perch and two ports on either side of the lens system. These ports were later fitted with a Newport SMA bulkhead

and FC/PC bulkhead to properly interact with our fibers. The fibers we used were an FC/PC to FC/PC multimode fiber to connect our 785nm excitation source laser module and a SMA to SMA multimode fiber to connect to the Ocean Insights Raman spectrometer. This Raman spectrometer allows for the analysis of our water sample through the OceanView software provided by Ocean Insights.



**Figure 5.7.3** Spectrum from testing through a water sample.

As seen in our spectrum in figure 5.7.3 we observed a 785 nm peak when lasing through free space. This confirmed our lasers wavelength for the use of Raman spectroscopy. We were able to use the OceanView Raman view to view Raman shifts going through our inline water. By comparing a known spectrum of pure water as a baseline against our inline water we can confirm the purity of the water.

## 6.0 Administrative Content

Community gardens can typically cost anywhere from \$4000 to \$10000 depending on the size, location, and complexity of the garden. That said, we wanted to develop a community garden at the lowest possible cost that can be built with minimal technical knowledge if the instructions on how to build the project were given.

### 6.1 Final Budget with System Breakdown

This budget was utilized in the design and construction of a Self-Sustaining Hydroponic Greenhouse. When drafting the initial budget estimate, we estimated the major components based on the current average price of the different units. The components are itemized in the budget. Much of our funding will be from sponsors. The remaining funding will be provided by project team members. A contingency of \$300 was included in the budget; this will be in case of emergencies, unplanned minor expenses and possible instrument repair or replacement.

NFT Structure				
Query	Quantity	Store	Unit Price	Total
3x4 A Elbo	6	Home Dep	4.38	26.28
3x4 Alumir	2	Home Dep	17.98	35.96
90 Degree	1	<a href="#">Home Dep</a>	2.85	2.85
1.5 inch PV	8	<a href="#">Home Dep</a>	4.17	33.36
1.5 inch PV	1	<a href="#">Home Dep</a>	1.39	1.39
1.5 inch 10	10	<a href="#">Home Dep</a>	6.57	65.7
3x4 A Elbo	8	<a href="#">Home Dep</a>	4.74	37.92
3x4 Vinyl D	2	<a href="#">Home Dep</a>	4.58	9.16
1 inch Roc	1	<a href="#">Amazon</a>	18.18	18.18
2 lbs xGarc	1	<a href="#">Amazon</a>	11.95	11.95
Leadrise 1	1	<a href="#">Amazon</a>	7.44	7.44
20 ft 3/8 in	1	<a href="#">Home Dep</a>	12.25	12.25
1.5 inch 3-V	1	<a href="#">Amazon</a>	26.99	28.88
<b>Total</b>				<b>291.32</b>

Rainwater Collection (Central and Sub 1)				
Query	Quantity	Store	Unit Price	Total
pH Sensor	1	DFRobot	64.9	64.9
Rubbermaid 45 Ga	2	Home Dep	64.97	129.94
90 Degree 1.5 inch	5	Home Dep	2.85	14.25
Rubbermaid 45 Ga	1	Home Dep	38.97	38.97
1.5 inch PVC Tee	1	Home Dep	4.17	4.17
1.5 inch x 1.25 inc	1	Home Dep	3.44	3.44
1.5 inch x 1.25 inc	4	Home Dep	4.11	16.44
SS Clamp	2	Home Dep	1.88	3.76
HDX 55 Gallon Sto	1	Home Dep	41.98	41.98
1 inch OD x .75 inc	1	Home Dep	26.93	26.93
48 inch x 84 inch S	1	Home Dep	10.98	10.98
500 W Power Inve	1	Amazon	36.37	36.37
6 Stage Water Filti	1	Amazon	256.79	256.79
Conductivity K 1.0	1	AtlasScien	199.99	199.99
Level Sensor	2	Anndason	2.5	5
Plastic Water Elec	1	Bedaun	12.99	12.99
3/8" Barbed Hose	1	DERNORD	8.09	8.09
1/2" Male Thread	1	YMZ	6.99	6.99
Water Pump Strain	1	Dreyoo	9.99	9.99
4 Pack - EPAuto 30	1	EPAuto	12.87	12.87
12V DC Fresh Wat	1	Bayite	18.85	18.85
Plastic Waterproof	1	Makelele	21.39	21.39
20 ft 3/8 in tubein	1	Home Dep	12.25	12.25
Pool Noodles	1	Dollar Tree	1.25	1.25
1/2 tubing/ elbow	1	Home Dep	16.06	16.06
5M High Head DC	1	HiLetgo	12.99	12.99
<b>Total</b>				<b>987.63</b>

Photovoltaic System				
Query	Quantity	Store	Unit Price	Total
Behr Prem	1	Home Dep	20.98	20.98
4 inch Mer	1	Home Dep	3.47	3.47
5 inch Hing	3	Home Dep	7.47	22.41
Chest Latc	1	Home Dep	3.51	3.51
2x4 d.625	5	Home Dep	4.98	24.9
Rigid Tie A	8	Home Dep	2.68	21.44
ZMAX Rigid	2	Home Dep	3.58	7.16
Simpson #1	2	Home Dep	14.28	28.56
200 W Mo	1	Amazon	213.99	213.99
Battery	1	Amazon	203.29	203.29
<b>Total</b>				<b>549.71</b>

Nutrient/pH System				
Query	Quantity	Store	Unit Price	Total
HDX 7 Gall	4	Home Dep	7.63	30.52
Peristaltic	5	Amazon	15.99	85.55
Level Senc	3	<a href="https://www">https://www</a>	2.5	14.99
pH Down L	1	<a href="https://www">https://www</a>	33.88	33.88
pH Up Liqu	1	<a href="https://www">https://www</a>	31.29	31.29
Liquid Nutr	1	<a href="https://www">https://www</a>	23.42	23.42
Check Valv	5	<a href="https://www">https://www</a>	1.91	9.57
Hose Barb	5	<a href="https://www">https://www</a>	1.404	7.02
Silicone Tul	1	<a href="https://www">https://www</a>	13.99	13.99
pH Calibrat	1	<a href="https://www">https://www</a>	13.62	13.62
Command	1	Home Dep	6.07	6.07
<b>Total</b>				<b>269.92</b>

Electronics/Control System				
Query	Quantity	Store	Unit Price	Total
TPSM84203EAB	1	<a href="https://octo">https://octo</a>	8.04	8.04
FSM2JSMAATR	2	<a href="https://octo">https://octo</a>	0.32	0.64
GRT31CR61H106	1	<a href="https://octo">https://octo</a>	0.63	0.63
C3216X5R1E476M	2	<a href="https://octo">https://octo</a>	0.96	1.92
MSP430FR2476TI	1	<a href="https://octo">https://octo</a>	3.45	3.45
CR1206-JW-103E	15	<a href="https://octo">https://octo</a>	0.042	0.63
CH340	1	<a href="https://www">https://www</a>	8.69	8.69
ESP8266 ESP-01	1	<a href="https://www">https://www</a>	2.25	8.99
ULQ2003AN	2	<a href="https://octo">https://octo</a>	0.78	1.56
SN74HC151N	2	<a href="https://octo">https://octo</a>	0.6	1.2
22284012	74	<a href="https://octo">https://octo</a>	0.04	2.96
CR1206-JW-102E	3	<a href="https://octo">https://octo</a>	0.1	0.3
RT1206BRD075KI	3	<a href="https://octo">https://octo</a>	0.62	1.86
40mm Fan	4	<a href="https://www">https://www</a>	2.75	10.99
12V 4A Voltage Sta	1	<a href="https://www">https://www</a>	26.69	26.69
Heat Sink	1	<a href="https://www">https://www</a>	8.99	8.99
PCB Revision 2	10	<a href="http://jlcpcb.com">jlcpcb.com</a>	4.81	48.14
<b>Total</b>				<b>135.68</b>

Greenhouse				
Query	Quantity	Store	Unit Price	Total
Greenhouse	1	Aosom	537.51	537.51
4 foot x 8	1	Lowe's	59.68	59.68
Mulch	3	Home Dep	3.33	9.99
<b>Total</b>				<b>607.18</b>



Miscellaneous Spending/Tools				
Query	Quantity	Store	Unit Price	Total
Silicon	2	Home Dep	11.98	23.96
Box Cutter	1	Home Dep	3.48	3.48
Marine Lo	2	Home Dep	17.48	34.96
Caulk Gun	1	Home Dep	4.28	4.28
1.5" Rockv	2	Amazon	9.65	19.3
Salad Bow	2	Home Dep	1.69	3.38
Jiffy Peat S	1	Home Dep	9.97	9.97
8oz PVC Ce	1	Home Dep	10.94	10.94
Ryobi Impa	1	Home Dep	6.77	6.77
Ring Termi	1	Home Dep	5.4	5.4
2 inch Bi-N	1	Home Dep	18.97	18.97
Disposable	1	Home Dep	2.98	2.98
600PCS 2	1	<a href="https://www">https://www</a>	9.99	9.99
PETG 3D I	1	<a href="https://www">https://www</a>	22.35	22.35
SMA Male	1	<a href="https://wv">https://wv</a>	12.99	12.99
4 inch Lon	1		6.99	6.99
F-MA-SM-	1	Newport	14.07	14.07
F-MA-FC-F	1	Newport	8.61	8.61
M2 screws	1	ACE	4	4
M3 Spacers	1	<a href="https://www">https://www</a>	14.78	14.78
Dupont Co	1	<a href="https://www">https://www</a>	36.99	36.99
Heat Shrin	1	<a href="https://www">https://www</a>	8.35	8.35
Terminal Ri	1	<a href="https://wv">https://wv</a>	10.05	10.05
24 Gauge V	1	<a href="https://www">https://www</a>	12.99	12.99
Hose Clamp	1		11.99	11.99
Fuse Holde	1		11.99	11.99
Mesh Pot C	1		14.95	14.95
<b>Total</b>				<b>345.48</b>

Total Spending/Total Cost	
<b>Total Spending</b>	3738.45
<b>Total Cost of Current System</b>	3186.92
<b>Expected Cost of Total System</b>	5082.74
<b>Projected Cost for Future System</b>	~5000

**Table 6.1.1** Final budget for overall project span

## 6.2 Project Milestones

Over our two semesters, there were numerous milestones we had to hit to not only stay on track with our project but also to ensure the project functioned in the end. We provide an overview of our project milestones over the two semesters below.

### 6.2.1 Senior Design 1

Senior Design 1 had a large number of milestones that needed to be hit in order to ensure the project stayed on track as we moved through the fall semester and into the spring semester. Aside from the writing milestones we were required to achieve as we progressed throughout the semester, we also added in quite a few additional milestones as well. Some of these milestones include ensuring our demo tests were on schedule to ensure the optical components of our project would function the way we expected as well as prototyping some of the other systems that existed in our project. Throughout the semester, we hit almost all of our milestones; only a few have had to roll over to the spring semester. The most important milestones for us in Senior Design 1 were expected to be our prototyped designs as well as our finalized project design for each of the sub-systems. These two milestones acted as guiding factors for our work in Senior Design 2.

Number	Milestone	Completion Week
1	Initial Product Documentation (Divide and Conquer 1.0)	4
2	Search for potential sponsor	4
3	Meet with advisor to confirm project idea	5
4	Research systems and create initial designs	5
5	Revised Product Documentation (Divide and Conquer 2.0)	6
6	Confirm design of power management system	6
7	Create initial software design for microcontroller	7
8	Update system designs (software, water retrieval, nutrient delivery)	7
9	Prototype spectrophotometer	7
10	Prepare and present initial demo for initial optical design	8
11	Finalize optical demo for final PSE demonstration	10
12	Begin purchasing components and PCB	10
13	Finalize 60 Page Draft	11
14	Complete final project designs for every sub-system included in the greenhouse	13
15	Finalize 100 Page Draft	13
16	Complete Final Report	16

**Table 6.2.1** Project milestones for Senior Design 1

### 6.2.2 Senior Design 2

Based on the completed milestones and work done in Senior Design 1, we then constructed the following projected milestone calendar to keep us on track for project completion throughout the spring semester. As mentioned in our goals, the milestones prioritize the completion of certain systems over others to ensure the system achieved our core goals. The present milestone calendar focuses solely on the construction of our project without

considering the milestones we had to achieve with regard to demonstrations, website construction, paperwork, and other deliverables. Our primary focus in creating this milestone calendar was to have a clear pathway in mind to how we would achieve the completion of this greenhouse. This is largely due to the fact that our project is of a very large scale, and we needed ample time for the construction, testing, and innovating.

<b>Number</b>	<b>Milestone</b>	<b>Completion Week</b>
1	Construct housing and hydroponic bed	1
2	Begin integration of rainwater collection system	2
3	Integrate sensors into sub-reservoirs	2
4	Connect reservoirs to hydroponic beds	3
5	Connect water filtration/analysis system	4
6	Begin integration of nutrient/pH system	5
7	Begin software design for pumping systems and sensor networks	5
8	Install solar panels outside of greenhouse	6
9	Deliver power to each of the systems	6
10	Begin testing hydroponic systems	7
11	Plant plants	7
12	Design plant profiles in software	8
13	Complete nutrient selection software and interface	9
14	Complete integration sensors, pumps, and housings	10
15	Complete testing	11
16	Explore advanced and stretch goal options	12
17	Make additions, improvements, and changes as needed based on test results and final analysis	13-15
18	Deliver Product	15

**Table 6.2.2** Project milestones for Senior Design 2

### **6.3 Sponsors**

In order to fund this project, we sought out several sponsors to assist us not only in purchasing the materials necessary, but also to loan us land, components, and knowledge necessary to complete the project as well.

The first and primary sponsor for this project is the Oviedo Historical Society. The Oviedo Historical Society is a local nonprofit organization in the City of Oviedo whose purpose is to help preserve the community identity of Oviedo by collecting and disseminating knowledge about local history, serve as a repository for documents and artifacts relating to Oviedo history, promote the preservation and marking of historic sites and buildings in the Oviedo area, and foster interest in local, state, national and world history. One of their

newer goals as an organization is to promote a forward-looking attitude in the city to ensure that Oviedo residents are taking an active role in writing Oviedo's history by being mindful of our past. They have agreed to sponsor this project in an effort to promote sustainable action within the municipality while also creating an interesting dichotomy between historic Oviedo and future Oviedo. Since the city was largely an agriculturally based economy for much of the time it has existed, the Historical Society felt that promoting community gardens within the city would serve an excellent benefit to show residents how Oviedo's past can assist in informing its future. They hope that with the completion of our project, they will be able to employ the greenhouse as a community garden to supply nutritious, organic foods to the local food banks. Their sponsorship includes \$1500 and a promise for land use to construct the greenhouse on their museum's property.

The second sponsor for this project was Ocean Insight. We contacted Ty Olmstead from the company regarding the use of one of their Raman spectrometers as well as a 785 nm fiber laser source. We were also in need of the fibers necessary to connect and transmit the laser from the source through the water sample into the Raman spectrometer. These fibers were loaned to us by Dr. Rodrigo Amezcua Correa. We received a 785 nm laser source that Ocean Insight provided to a group in the past as well as a suitable 785 nm Raman spectrometer that was also loaned to a group in the past. We were granted access to Ocean Insights software, Ocean View, to be able to make use of the Raman spectrometer and laser module. This enabled us to use Raman spectroscopy in our water analysis system.

We also approached the Oviedo Rotary Club regarding sponsoring our project through a monetary donation. The Oviedo Rotary Club sponsors numerous service projects around the city that are intended to help various demographics depending on the project. They have demonstrated interest in the past in larger scale initiatives that can provide a service to the greater Oviedo community, and we believed that this project would be able to provide ample benefits to dozens of families in Oviedo. The Rotary Club welcomes members all across Oviedo, and its membership includes some of the most involved and influential members of the community. There are few organizations in Oviedo better suited to sponsor this project than the Rotary Club of Oviedo due to their widespread recognition and influence in the city. We sought a monetary donation of \$1000 in order to offset some of our costs in addition to providing access to greater system enhancements that unfortunately were unattainable due to their high costs. Ultimately, we were not able to secure this sponsorship until we were able to provide a proof of concept system which we were able to do at the completion of this project.

## **7.0 Conclusion**

When we initially decided to pursue this project, we all had only a foundational understanding of what it takes to construct and operate a hydroponic garden. We knew little of the specifics for growing a given plant species, purifying rainwater, or even analyzing water for the specific metrics required for our project. Knowing there was a great deal of research and design ahead of us to be able to effectively execute this project, we laid out a plan for how we would assess the system with hope of designing a system that would be effective in combating the many issues associated with food insecurity.

We began by outlining the different systems we hoped to include in the design of the project, and we established goals associated with each of those systems in an effort to mitigate any problems an organization would encounter when trying to operate this greenhouse. Having broken each system up into core, advanced, and stretch goals, we were able to establish the objectives we would need to accomplish in order to construct the overall project. This in turn supplied us with engineering requirement specifications that would influence the actual design aspects of the greenhouse to give us measurable and testable results.

Following the decisions regarding the specifications, we took an in-depth look at each of the systems and drew concept designs to meet our specifications. These concept designs allowed us to conduct research into the various components we planned to use as well as understand much of the science that would be considered throughout the construction. We had to consider the costs associated with each component, the integrability of the components with the system as a whole, and the possible alternative uses of the components as well.

Of course, we encountered numerous issues over the course of the project. Namely, we lost one of our original group members which resulted in our having to scale the project back several times. With a reduction in our available knowledge base, we had to conduct additional research into systems that would have been covered by our former group mate. This proved to be rather difficult as we had to gain increased knowledge of electronics and how they can interact with the other parts of our system. This was coupled with the fact that we had to do considerable research into some of the more complicated systems such as the water analysis system in which we utilize in-line Raman spectroscopy to test the quality of the water post-filtration. Raman spectroscopy proved to be a very advanced system and it is difficult to integrate, but with the help of Ocean Insight, we were able to acquire the components and software necessary for it to be properly integrated.

In all, we set out to develop a self-sufficient hydroponic greenhouse that will be able to operate independently from any gridded network of a municipality. We believe that the design and research we have completed in this report is more than sufficient to continue developing a viable solution to combat the growing problems of food insecurity throughout America. Our solution was relatively cheap, highly efficient, and readily accessible to any localities that should choose to implement sustainable initiatives such as community gardens in their cities. Our work will continue despite this courses completion to bring a fully functioning greenhouse to life for the residents of the City of Oviedo. We already have begun communications with the city about future installations of a full-fledged system.

## 8.0 About Us



**Connor DiMatteo** is a 23-year-old Photonic Sciences and Engineering student with concurrent minors in Physics, Mathematics, and Prelaw. Connor is very passionate about sustainability and hopes this project will be the first step in improving sustainable initiatives in his hometown of Oviedo. He plans to work for a defense contractor to continue to explore the field of engineering in a cross-functional environment.



**George Kiriazes** is a 21-year-old Photonic Sciences and Engineering student. George has worked with many interdisciplinary groups throughout his college career during internships with Townes Institute Science and Technology Experimentation Facility, UCF's wave propagation research group, and the NASA Glenn quantum communication space communications and navigation group.



**Kaleb Morgan** is a 24-year-old Computer Engineering student. Kaleb has been working with computers and electronics for several years developing both software and hardware solutions to outstanding problems. Kaleb currently works with a small team of engineers at Regal Marine automating tasks for the boating industry.

## 9.0 Work Cited

1. World Bank Group. (2022, October 31). *Food security: Rising food insecurity in 2022*. The World Bank. Retrieved from <https://www.worldbank.org/en/topic/agriculture/brief/food-security-update>
2. *Charge controller* - Wikipedia, [https://en.wikipedia.org/wiki/Charge\\_controller](https://en.wikipedia.org/wiki/Charge_controller).
3. *MSP430G2553 data sheet, product information and support* | TI.com, <https://www.ti.com/product/MSP430G2553>.
4. “Wi-Fi.” *Wikipedia*, Wikimedia Foundation, 2 Oct. 2022, <https://en.wikipedia.org/wiki/Wi-Fi>.
5. “ESP8266.” *Wikipedia*, Wikimedia Foundation, 7 Sept. 2022, <https://en.wikipedia.org/wiki/ESP8266>.
6. “IEEE 802.11.” *Wikipedia*, Wikimedia Foundation, 5 Oct. 2022, [https://en.wikipedia.org/wiki/IEEE\\_802.11](https://en.wikipedia.org/wiki/IEEE_802.11).
7. “Internet protocol suite.” *Wikipedia*, Wikimedia Foundation, 29 Sept. 2022, [https://en.wikipedia.org/wiki/Internet\\_protocol\\_suite](https://en.wikipedia.org/wiki/Internet_protocol_suite)
8. *Wireless LAN* - Wikipedia, [https://en.wikipedia.org/wiki/Wireless\\_LAN](https://en.wikipedia.org/wiki/Wireless_LAN).
9. *Internet protocol suite* Wikipedia, [https://en.wikipedia.org/wiki/Internet\\_protocol\\_suite](https://en.wikipedia.org/wiki/Internet_protocol_suite).
10. Nayan, Faysal & Ullah, S.M.Safayet & Saif, S.. (2016). *Comparative analysis of PV module efficiency for different types of silicon materials considering the effects of environmental parameters*. 1-6. 10.1109/CEEICT.2016.7873089.
11. Lenardic, D. (2015, December 23). *Photovoltaics - Historical Development*. <http://www.pvresources.com/en/introduction/history.php#:~:text=The%20first%20silicon%20monocrystalline%20solar,materials%20for%20solar%20cell%20production>
12. *Types of Solar Panels (2020)* - GreenMatch. (2020, March 10). <https://www.greenmatch.co.uk/blog/2015/09/types-of-solar-panels>
13. *Low-Cost Multispectral Sensor Array for Determining Leaf Nitrogen Status*, Nitrogen 2020, 1(1), 67-80; <https://doi.org/10.3390/nitrogen1010007>
14. “GSM.” *Wikipedia*, Wikimedia Foundation, 8 Oct. 2022, <https://en.wikipedia.org/wiki/GSM>
15. “Bluetooth.” *Wikipedia*, Wikimedia Foundation, 5 Oct. 2022 <https://en.wikipedia.org/wiki/Bluetooth>
16. *Set Up of an Automatic Water Quality Sampling System in Irrigation Agriculture*, Sensors 2014, 14(1), 212-228; <https://doi.org/10.3390/s140100212>
17. Wang, Olivia. “What Are Standards? Why Are They Important? - IEEE SA.” *IEEE Standards Association*, 18 Oct. 2022, <https://standards.ieee.org/beyond-standards/what-are-standards-why-are-they-important/>.
18. “IEEE Standards Association.” *Wikipedia*, Wikimedia Foundation, 21 Aug. 2022, [https://en.wikipedia.org/wiki/IEEE\\_Standards\\_Association](https://en.wikipedia.org/wiki/IEEE_Standards_Association).
19. “Home.” *JTC 1*, 25 Aug. 2022, <https://jtc1info.org/>.
20. “ISO/IEC 9899:2018.” *ISO*, 13 Oct. 2020, <https://www.iso.org/standard/74528.html>.
21. “IEEE 802.” *Wikipedia*, Wikimedia Foundation, 19 Aug. 2022, [https://en.wikipedia.org/wiki/IEEE\\_802](https://en.wikipedia.org/wiki/IEEE_802).

22. “Data Link Layer.” *Wikipedia*, Wikimedia Foundation, 31 Oct. 2022, [https://en.wikipedia.org/wiki/Data\\_link\\_layer](https://en.wikipedia.org/wiki/Data_link_layer).
23. “IEEE 802.2.” *Wikipedia*, Wikimedia Foundation, 23 Apr. 2022, [https://en.wikipedia.org/wiki/IEEE\\_802.2](https://en.wikipedia.org/wiki/IEEE_802.2).
24. “American National Standards Institute.” *Wikipedia*, Wikimedia Foundation, 29 July 2022, [https://en.wikipedia.org/wiki/American\\_National\\_Standards\\_Institute](https://en.wikipedia.org/wiki/American_National_Standards_Institute).
25. “Take Online Courses. Earn College Credit. Research Schools, Degrees & Careers.” *Study.com | Take Online Courses. Earn College Credit. Research Schools, Degrees & Careers*, <https://study.com/academy/lesson/design-constraints-in-engineering-definition-example.html>.
26. “Real World Constraints and Engineering Standards.” *Arxterra*, [https://www.arxterra.com/realistic-constraints-and-engineering-standards/#Program\\_Constraints](https://www.arxterra.com/realistic-constraints-and-engineering-standards/#Program_Constraints).
27. “Charts: TTI, Inc.” *Charts / TTI, Inc.*, <https://www.tti.com/content/ttiinc/en/apps/lead-time-trends/charts.html?ind=Commercial&indc=COMM&com=Sensors&comc=sen&entity=ndc>.
28. “Framework Archive.” *B. Engineering Design*, [https://www.nagb.gov/naep-subject-areas/technology-and-engineering-literacy/framework-archive/2014-technology-framework/toc/ch\\_2/design/design2.html#:~:text=Constraints%20are%20limitations%20on%20the,requirements%20for%20a%20successful%20solution](https://www.nagb.gov/naep-subject-areas/technology-and-engineering-literacy/framework-archive/2014-technology-framework/toc/ch_2/design/design2.html#:~:text=Constraints%20are%20limitations%20on%20the,requirements%20for%20a%20successful%20solution).
29. *Basic Electricity Safety - Occupational Safety and Health Administration*. [https://www.osha.gov/sites/default/files/2019-04/Basic\\_Electricity\\_Materials.pdf](https://www.osha.gov/sites/default/files/2019-04/Basic_Electricity_Materials.pdf).
30. *OC-ESP-WROOM-02 Datasheet En - Mouser Electronics*. [https://www.mouser.com/datasheet/2/891/0c\\_esp\\_wroom\\_02\\_datasheet\\_en-1365805.pdf](https://www.mouser.com/datasheet/2/891/0c_esp_wroom_02_datasheet_en-1365805.pdf).
31. Rhuanito Soranz Ferrarezi & Roberto Testezlaf (2016) *Performance of wick irrigation system using self-compensating troughs with substrates for lettuce production*, *Journal of Plant Nutrition*, DOI: 10.1080/01904167.2014.983127
32. *Hydroponic Irrigation System – Feasible, Suitable and Sustainable Method* <http://www.ijimes.org/wp-content/uploads/2020/05/41.pdf>
33. Lynch, C. (2018, May 2). *How Walt Disney World's farm grows the most magical produce on Earth*. *Farm Flavor*. Retrieved from <https://farmflavor.com/florida/walt-disney-world-farm-grows-magical-produce-earth/>
34. Spyrou, C. (2018, August 24). *Disney World has a magical greenhouse where giant produce is grown*. *Food Beast*. Retrieved from <https://www.foodbeast.com/news/disney-world-giant-produce/>
35. *DIY Ebb And Flow Hydroponic System* <https://www.backyardgardenlover.com/ebb-and-flow-hydroponic-system/>
36. *How Nutrient Film Technique (NFT) Hydroponic Systems Work* <https://puregreensaz.com/nutrient-film-technique/>
37. Korea. “Post Navigation.” *HM Digital*, 9 Nov. 2016, [https://hmdigital.com/knowledge\\_base/the-relationship-between-tds-and-electrical-](https://hmdigital.com/knowledge_base/the-relationship-between-tds-and-electrical-)



- [conductivity/#:~:text=Total%20Dissolved%20Solids%20\(TDS\)%20and,water's%20ability%20to%20conduct%20electricity\).](#)
38. Goddek, Simon, et al. *Aquaponics food production systems: combined aquaculture and hydroponic production technologies for the future*. Springer Nature, 2019.
  39. *How Nutrient Film Technique (NFT) Hydroponic Systems Work*  
<https://puregreensaz.com/nutrient-film-technique/>
  40. LO;, Taylor M;Elliott HA;Navitsky. "Relationship between Total Dissolved Solids and Electrical Conductivity in Marcellus Hydraulic Fracturing Fluids." *Water Science and Technology : a Journal of the International Association on Water Pollution Research*, U.S. National Library of Medicine, <https://pubmed.ncbi.nlm.nih.gov/29722685/#:~:text=Because%20TDS%20measurement%20is%20time,is%20a%20constant%20of%20proportionality.>
  41. *Growing food in space: A comparison of LED and solar-fiber-optic technologies*  
<https://digitalcommons.usu.edu/spacegrant/2020/papers/16/>
  42. *Which part of the light spectrum is used for photosynthesis?*  
<https://www.2hraquarist.com/blogs/light-3pillars/light-wavelength-indepth>
  43. *Liquid EC & TDS Sensor - Seeed Studio*.  
<https://files.seeedstudio.com/products/314990634/res/Liquid%20EC%20and%20TDS%20Sensor%20Datasheet%20v1.1.pdf>.
  44. *MSP430FR2476 Launchpad™ Development Kit (LP MSP430FR2476) - Ti.com*.  
<https://www.ti.com/lit/ug/slau802/slau802.pdf>.
  45. "Universal Asynchronous Receiver-Transmitter." *Wikipedia*, Wikimedia Foundation, 5 Nov. 2022,  
[https://en.wikipedia.org/wiki/Universal\\_asynchronous\\_receiver-transmitter](https://en.wikipedia.org/wiki/Universal_asynchronous_receiver-transmitter).
  46. Burnett, Colin M.L. "File:SPI 8-bit circular transfer.svg." *Wikimedia Commons*,  
[https://commons.wikimedia.org/wiki/File:SPI\\_8-bit\\_circular\\_transfer.svg](https://commons.wikimedia.org/wiki/File:SPI_8-bit_circular_transfer.svg).
  47. "PC." *Wikipedia*, Wikimedia Foundation, 9 Nov. 2022,  
<https://en.wikipedia.org/wiki/I%C2%B2C>.
  48. *Max3222 3-V To 5.5-V Multichannel RS-232 Line Driver and ... - Analog*.  
<https://www.ti.com/lit/ds/symlink/max3222.pdf>.
  49. *ULN200X, ulq200x High-Voltage, High-Current Darlington Transistor ...*  
<https://www.ti.com/lit/ds/symlink/ulq2003a.pdf>.
  50. Aitavade, E. N., et al. "An overview of peristaltic pump suitable for handling of various slurries and liquids." *Journal of Mechanical and Civil Engineering* (2012): 19-24.
  51. Musayev, Eldar, and Sait Eser Karlik. "A novel liquid level detection method and its implementation." *Sensors and Actuators A: Physical* 109.1-2 (2003): 21-24.
  52. Shih, Wei-Chuan, K. B. Bechtel, and Michael S. Feld. "Noninvasive glucose sensing with Raman spectroscopy." *Analytical chemistry of in vivo glucose measurements*. Hoboken, NJ: John Wiley & Sons (2009): 391-419.
  53. Li, Zhiyun, et al. "Raman spectroscopy for in-line water quality monitoring—Instrumentation and potential." *Sensors* 14.9 (2014): 17275-17303.
  54. Downes, Andrew, and Alistair Elfick. "Raman spectroscopy and related techniques in biomedicine." *Sensors* 10.3 (2010): 1871-1889.
  55. *Analog | Embedded Processing | Semiconductor Company | Ti.com*.  
<https://www.ti.com/lit/ug/slau445i/slau445i.pdf>.

56. "Baud Rate and Its Importance." *GeeksforGeeks*, 19 Oct. 2021, <https://www.geeksforgeeks.org/ baud-rate-and-its-importance/>.
57. *Different types of water filters [21 kinds explained]*. Home Water Research. (2022, June 21). Retrieved December 5, 2022, from <https://homewaterresearch.com/different-types-of-water-filters/#:~:text=Types%20of%20water%20filtration%201%20Sediment%20Filters%202,7%20Ultrafiltration%20%28UF%29%208%20Activated%20Alumina%20More%20items>
58. Winfield, S. (2022, November 11). *What is reverse osmosis & how does it work?* Water Defense. Retrieved December 5, 2022, from <https://waterdefense.org/water-filter/reverse-osmosis/how-works/#:~:text=A%20reverse%20osmosis%20system%20works%20by%20forcing%20water,through%20a%20pump%2C%20forcing%20it%20through%20a%20membrane.>
59. *Activated carbon filter*. FlixWater. (2022, June 27). Retrieved December 5, 2022, from <https://flixwater.com/activated-carbon-filter/>
60. Wikimedia Foundation. (2022, November 16). *Adsorption*. Wikipedia. Retrieved December 5, 2022, from <https://en.wikipedia.org/wiki/Adsorption>
61. "Linear Regulator." *Wikipedia*, Wikimedia Foundation, 9 Aug. 2022, [https://en.wikipedia.org/wiki/Linear\\_regulator#:~:text=In%20electronics%2C%20a%20linear%20regulator,in%20a%20constant%20voltage%20output.](https://en.wikipedia.org/wiki/Linear_regulator#:~:text=In%20electronics%2C%20a%20linear%20regulator,in%20a%20constant%20voltage%20output.)
62. Standard Guide for Testing the Resolution of a Raman Spectrometer. (2014). *Annual Book of ASTM Standards*, 03.06. <https://doi.org/10.1520/E2529-06R14>
63. Dunn, Bruce & Singh, Hardeep. (2016). Electrical Conductivity and pH Guide for Hydroponics. 10.13140/RG.2.2.20271.94885.