

Two-Cycle Power

A hybrid solar and hydroelectric power system

University of Central Florida

Department of Electrical Engineering and Computer Science

Senior Design II - Group 37

Alexander Carpenter - Electrical Engineering

Brian Dunsmore - Electrical Engineering

Christian Cruz Paez - Electrical Engineering

Yonder Salomon - Electrical Engineering



Table of contents

1.0 Executive Summary	1
2.0 Project description	3
2.1 Goals.....	3
2.1.1 Motivation	3
2.2 Objectives.....	4
2.3 Project challenges.....	4
2.4 Solutions.....	5
OBJ 3.0 Engineering Specifications	7
3.0.1 Hardware requirements.....	7
3.0.2 Software requirements	8
3.0.3 Key specifications.....	8
3.1 House of quality (HoQ).....	8
OBJ 3.2 Block Diagrams.....	11
3.2.1 Hardware Flow Diagram	11
3.2.2 Software Flow Diagram.....	12
OBJ 3.2.3 System Operations Under Normal Conditions	13
OBJ 4.0 Research and Part Selection	15
4.1 Solar Panels	15
4.2 Micro-hydro Generators	17
4.3 Hydro Pumps.....	18
4.4 Relays	19
4.5 Voltage regulator.....	19
4.5.1 Linear voltage regulators	20
4.5.2 Switching voltage regulators	20
4.5.3 Comparison and part selection	21
4.6 Batteries.....	22
4.6.1 Lithium-ion Battery	22
4.6.2 Nickel Metal Hydride Battery	23
4.6.3 Lead Acid Battery.....	25
4.6.4 Redox Flow Battery	26
4.6.5 Zinc-ion Battery.....	27
4.6.6 Comparison and Selection	28

4.7 Battery charge regulator	29
4.8 Power Inverters	31
4.9 Sensors	31
4.9.1 Temperature Sensor	32
4.9.2 Flow Rate Sensor.....	33
4.9.3 Voltage, Current, and Power Sensor	33
4.9.4 Light sensor	33
4.10 Microcontrollers	34
4.10.1 Host Microcontroller	34
4.10.2 Peripheral Microcontrollers	37
4.11 Wi-Fi Modules	38
4.11.1 Technology comparison: Bluetooth vs Wi-Fi	39
4.12 LCD display	40
4.12.1 TN LCD panel	40
4.12.2 VA LCD panel.....	41
4.12.3 IPS LCD panel.....	41
4.12.4 LCD selection.....	41
5.0 Project constraints	43
5.0.1 Physical Constraints	43
5.0.2 Software & Circuit Design Constraints	43
5.0.3 Marketing constraints	44
5.1 Related project standards	44
5.1.1 Standards in solar systems	45
5.1.2 Standards in battery systems.....	47
5.1.3 Standards in Micro Hydropower	47
5.1.4 Standards in PCB Design	48
5.1.5 Standards in System Installation.....	49
5.2 Other project standards.....	50
5.2.1 Standards in C/C++ Programming	50
5.2.2 Standards in technical documentation	50
5.2.3 Standards in System monitoring.....	51
5.2.4 Standards in Wi-Fi Communications	51
5.2.5 HTTP and LAMP Server Standards	52

6.0 System design	54
6.1 Power supply design.....	55
6.2 Inter-board Communication	57
6.3 Water pump and load design	59
6.4 Controls Design.....	60
6.5 System Testing	61
6.5.1 Solar panel	61
6.5.2 Hydro Generators and Water Pump.....	63
6.5.3 Battery Testing	64
6.5.4 Power source switching testing	65
6.6 Main Functions Testing.....	65
6.6.1 Discrete Input & PWM Control.....	66
6.6.2 AC to DC Circuit.....	67
7.0 System Power Sources / On System Indicators	69
7.1 Power Sources & Power Selection	69
7.1.1 Power Sources and Sensing.....	69
7.1.2 Battery Bypass Circuit.....	70
7.1.3 Power Source Selection	73
7.2 Battery Charging Circuit	77
7.3 Main Power Conditioning	79
7.3.1 5V Power Rail	79
7.3.2 3.3V Power Rail	80
7.3.3 AC to DC Power Conditioning.....	81
7.4 Rx/Tx Data Flow Indicators	82
7.5 Other Sensors Implementation	84
7.6 Source to Load Selection.....	85
7.7 In-System Programmability	88
7.8 LCD Display	90
7.9 Pump PWM Control.....	90
8.0 Software Architecture	92
8.1 Data Sources.....	92
8.1.1 Sensor Data.....	92
8.1.2 FET Logic Circuits	92

8.1.3 Output Data.....	93
8.2 Data Display & Records.....	93
8.2.1 LCD Information Display.....	93
8.2.2 Server Based information Display.....	94
8.3 Software Capabilities with Pseudocode	94
8.3.1 Main Function.....	94
8.3.2 Read Sensors Function	95
8.3.3 Engage Power Function.....	96
8.3.4 Relay Function.....	96
8.3.5 Power Monitor Function.....	97
8.3.6 LCD Display Function.....	97
8.3.7 Server Communications	98
8.4 Software Development Environment	105
8.4.1 MicroPython Language	105
8.4.2 MicroPython Libraries/Modules.....	106
8.4.3 Thonny.....	107
9.0 Marketing.....	109
9.1 Marketing methods.....	109
9.1.1 Commercials.....	109
9.1.2 Social Media.....	110
9.2 Target Audience	110
9.3 Market Uses.....	110
10.0 System housing and construction.....	112
10.1 Solar panel.....	112
10.2 Micro-hydro generators.....	112
10.3 Control boards and Microprocessors.....	113
10.4 Load housing.....	113
11.0 Administration	115
11.1 Project Milestones	115
11.2 COVID Restrictions & Alternative Meeting Strategies	116
11.3 Budget and Funding	116
11.4 Facilities and Equipment.....	118
11.5 Build, Prototype, Test, Evaluation Plan	118

11.5.1 Build Plan	118
11.5.2 Prototype Plan.....	118
11.5.3 Test Plan	119
11.5.4 Evaluation Plan.....	119
12.0 Conclusion	120
References.....	121
Complete System Schematic.....	128

Table of Figures

Figure 1 System power flow diagram.....	10
Figure 2: Software component flowchart	11
Figure 3: System output under normalized conditions	12
Figure 4: Solar panel specifications	14
Figure 5: Hydro generator specifications.....	15
Figure 6: Hydro pump operating specifications.....	17
Figure 7:Light sensor normalized response	32
Figure 8:Full System Functional Block	50
Figure 9:Interboard Communication RP2040.....	53
Figure 10:Interboard Communication ESP32.....	53
Figure 11:ESP2RPI Interrupt Line.....	54
Figure 12:ESP2RPI UART COMM	55
Figure 13:Power Sense Circuit.	62
Figure 14:Battery Bypass Circuit.....	63
Figure 15:Modified Battery Bypass Logic Circuit	65
Figure 16:Source Select Logic Circuit.....	66
Figure 17:Modified Source Select Logic Circuit.....	68
Figure 18:Battery Charger Circuit	70
Figure 19:Battery Charger Enable Logic Circuit.....	71
Figure 20:5V Power Rail DCDC Converter Circuit	72
Figure 21:5V Power Rail DCDC Converter Circuit.....	73
Figure 22:ACDC Circuit with 12V Regulated Output	74
Figure 23:Network Tx/Rx Data Flow Indicator Circuit	75

Figure 24:Pulse Stretching Signal Simulation Waveform	76
Figure 25:Temperature Sensor and Flow Sensor Peripherals Interface.....	77
Figure 26:Hydro Generated Power & External Load Select / Enable Logic Circuit	79
Figure 27:VBUS Rail External Load Enable Logic Circuit	80
Figure 28:In system Programmability MicroUSB Interfaces	81
Figure 29:Maximum Power Point Tracking Representation	82
Figure 30: Pump PWM Electronic Speed Controller	83
Figure 31:LAMP Server & Data Flow Architecture.....	91
Figure 32:Server Log Requests Frequency	92
Figure 33:Back-End Server PHPMyadmin Database View	92
Figure 34: Sensor Reading, Interboard Communication and Server Request Software Flowchart	93
Figure 35:Server Request Handler Flowchart.....	94
Figure 36:System Command Acknowledge using GET Request	95
Figure 37:Front-End Server Functional Diagram	96

List of Tables

Table 1 Engineering hardware requirements	7
Table 2 Engineering software requirements	8
Table 3 House of quality	9
Table 4:Voltage regulator specifications	19
Table 5:Lithium-ion battery specifications	21
Table 6:Nickel metal Hydride battery specifications.....	23
Table 7:Redox flow battery specifications	25
Table 9:Battery charge controller specifications	29
Table 10:Temperature sensor specifications.....	30
Table 11:Voltage, current, and power sensor specifications	31
Table 12:Microcontroller comparison	33
Table 13:SRAM and CPU clock comparison	34
Table 14:LCD Displays Comparison.....	38
Table 15:STD10P10F6 Parameters.....	63
Table 16: Optocoupler Datasheet Specifications	68

Table 17:Project Milestones 106

Table 18:Budget and Funding..... 108

1.0 Executive Summary

Energy consumption is increasing every day. This is due to the constant upgrades in technology. As we become more advanced, the need for more power arises. Power companies are scrambling to find new methods to meet the power needs of customers. However, with the need for more power, comes the need for better ways of making electricity. In today's market, green energy has increased in both popularity and efficiency. At an individual's home, solar panels are becoming a more prominent option for green energy solutions. This allows each customer to generate their own power and causes less reliability on conventional methods of power generation.

Another method of green energy is the use of hydro generation. Hydro plants have become the most efficient methods of making green energy. However, they can only be used for short periods of time. With this in mind, our goal is to combine the two forms of green energy generation together. Simply put, we would use solar energy to power a pump that would then push volumes of water across the hydro generators. This is the basic concept behind a two-cycle power system, which is when you use one source to power another source.

Solar power is changing the power industry. As the technology of the panels increases, the efficiency of the panels also increases. Panels are increasing in life and power output. Using one of the new types of panels, we have been able to produce enough power to constantly run a pump and charge a battery system. A battery system is key, because one of the major drawbacks to solar is the inconsistency of when power can be generated. Whenever there is a major storm or the sun sets for night, the power generated by the solar panel will either decrease or have nearly no output at all. Storing the excess power will allow us to maintain power needed for the pump.

Micro hydro generation is a newer form of green energy. This system is mainly used in places where running water, for example a downhill stream, is abundant. Micro hydro is also used in places where solar is less effective. These generators can range from 10 W to 600 W. Naturally, the amount of water that can be accessed will dictate the output of the system. Because of the reliance on a decent flow of water, hydro generation is only a viable option in certain locations and applications. For this project we have been designing a hydro system to have a set output. Power to provide the water flow will be given by the solar system. By powering our own water flow, the system will be able for use in a large area. Combining solar and hydro power together, we have created the two-cycle system that we set out to achieve.

With the use of the two power sources, we have needed a method of controlling the two. First controller will be for the battery charging system. Using a microcontroller, we have read the battery life and begin charging at a set threshold. Because batteries lose their max charge, when they are constantly charging, the system will need to adjust the power flow depending on the percentage of the battery. If the battery is at full charge, then the system will send constant power to the water pump. If the battery needs to be charged, the system will send small amounts of solar energy to keep it at the threshold. Successfully keeping the battery at the appropriate level, will ensure the customer that the pump will be able to push water across the hydro generator for the length of the night.

Another controller will be needed for the load of the system. Let's say, the system begins to produce more energy than is needed. When this happens, we need to know what to do with the excess energy. The best idea would be to send the excess power to the existing power grid. In order to perform this task, we have needed another microcontroller to read both the power coming into the house and the load demand of the house. If the incoming power is greater than the power needed, we have used a relay to connect the system and begin feeding power to the power company system. Being able to produce power for the whole system will make an individual home a generating source for the power company. Another benefit to connecting to the grid is if the need for power to run the pump is needed. Our system could use this power and still maintain a greater output.

In this project we have been simulating load demands of an average home. This will be an important factor in the design because we are having a microcontroller read the load and turn on the secondary power source to help when needed. Types of devices normally run throughout the day will include things like water heaters, A/C units, lights, and other devices which will determine the total amount of load the system will need to power. Also, we have need to manually adjust the load to match a normal day. Following an average trend, we have been increasing the load for different times of the day and decreasing it during others. This will show that the system is working as intended.

Currently in today's market, customers are choosing to use either solar or micro hydro power. Solar is the more popular type. Because micro hydro is limited to only certain areas of the world. New Zealand is an example, where solar is not able to be used, but micro hydro takes its place. With this system, we have been able to use both forms in conjunction with each other to produce enough energy. This essentially allows every home with this system implemented to become a small generation plant. By creating this type of system, the need for large industrial plants will be lessened. This will also reduce the need for fossil fuels and decrease the amount of pollution placed in the atmosphere. With the demand for more green energy, we feel this system will provide another method for power companies to generate more energy at a lower cost. This makes this system beneficial for both consumers and producers alike.

2.0 Project description

In this section we have discuss the goals and motivation for the design. The need for a set number of goals will help in moving the design along in a timely manner. It will also serve as time stamps in the completion. We have also discussed the motivation and challenges that could come up during the design. With each challenge we have demonstrate a proper solution.

2.1 Goals

Our motivations and main goals for this senior design project are centered around the implementation of the project more so than the final output. Through this design process and senior design project, we hope to be able to end up with a fully realized system that can switch from one power source to another freely. We also plan for the two-cycle power system to be able to generate enough power to be able to run our loads with no issues or lapses in power. Through this, we hope to prove that this type of system can be functionally worth it to implement and can give us a great insight into how a two-cycle power system could be implemented with more efficient technology in the future.

Another goal is to have the system monitor both powers supplied, and the power demanded by the system. This information will be key to being able to maintain the system over a period. It also will allow us to monitor the efficiency of our design. Once the data is collected, the user will be able to see live results via a web page. This means we have be transmitting the data wirelessly using wi-fi. Knowing what results we should expect, we have be able to watch for problems that occur or know if the system is running at optimal settings.

2.1.1 Motivation

We feel that the implementation of these types of systems is the future of energy generation. It is becoming apparent that these types of two cycle power systems will prevail as they can provide multiple means of consistent energy generation and failsafe that would allow for constant and consistent power. This means customers and consumers will be able to rely on a green energy system to fully meet their energy needs and will likely be able to make their money back on said system over a period of time.

Though we anticipate that the solar panels will be able to handle the load of the system on their own, complications arise when we attempt to use the battery as a method of powering our pumps for the water generation aspect of our project. This leads us to the main issue in our system, which is the implementation of the water pump and hydroelectric generator.

We also have great interest in the wireless aspect of our system and how implementing a wireless data aspect to our project will affect our design. With modern technology rapidly on the rise, we feel as though having some form of wireless aspect to our project is a must have. This type of wireless application is commonplace in today's markets and having it in our system will be interesting and challenging, while also being very practical and useful to understand for the future.

Understanding of how power system operate was a focus in designing this project. Coming from a strong electrical engineering background. We feel like diving deeper into the subject

would improve our knowledge of both types of systems, solar and hydro. This project will also help us to see firsthand how power is distributed and the use of wireless technology to help maintain a healthy grid over a set time period.

2.2 Objectives

For every project, we need a list of completable objectives that will assist in guiding the direction of our project. Outlining major objectives is a key step in fully realizing a project and coming up with a vision for what we want to achieve. With the goals and motivations in mind, we must actually go about choosing what our main objectives for the design will be, which will be how we outline what we really want the project to do.

For the project, we have three main objectives that we want to accomplish. The focus of this project will be to have the system be able to run the system using either our solar panels or our hydroelectric system. This will ensure that the core of our two-cycle power system will be able to function properly at a baseline level, as if this part of our project does not work then it certain the rest of our project will not work as intended.

Our second goal would be to be able to switch from using our solar panels to power the load to using our hydroelectric system to handle the load interchangeably and have our system be dynamic. This would mean that during overcloud periods of the day, we would be able to switch automatically from having our solar system attempt to power the load to being able to fill in gaps using our hydroelectric system.

Our third goal is primarily focused on the software aspect, and entails having all the information and data sent to a webpage or mobile app which the user can sign in to at any point or location to monitor their system data. This requires a large web of software information systems coming together to pull data from our sensors, average the data obtained from the system throughout the day, and other useful things which will allow the user to be more in tune with their system and see it functioning properly.

2.3 Project challenges

In this project, the main issue with our two-cycle power system is the overall efficiency of the system as we take the battery system and then hydro generation system into consideration. With every form of energy conversion and every transfer of energy, there is a loss of some sort. This is especially true when taking into consideration storing electricity to be used later in running a motor to generate electricity again.

Then, we have the challenge of keeping the cost low. When attempting to keep costs low, we must be sure we are not sacrificing too much in the other categories for our project. Getting much lower cost solar panels would allow us to greatly decrease the cost of our project but would obviously significantly impact the most important aspects of our system. Because of this, our project needs to take into consideration cost versus performance at every step, as spending excess money on unneeded power would be a costly mistake.

Another challenge we face is that of power output. With a system that may not end up being highly efficient and one that attempts to keep the cost relatively low, we face the inevitable issue of lower power output. This is because the power generating aspects of our solar cells and submersible water pumps will end up being the most expensive parts of our

project. This means that in order to get parts at lower prices, we have need to find some sort of balance between meeting our target output power and meeting our budget constraints.

Relaying the voltage, current and power wirelessly will be a challenge. From initial research and testing proved it could be done. However, the problem comes in the range of Bluetooth technology the chips use. While testing the system we see that it can broadcast to a secure web site. Once, we started getting a response, then started moving the system further from the Wi-Fi source. Because our project will have to need to be outside. It could become out of range from the internet source.

Another issue we face is that of the global chip shortage. This is an event that has been ongoing in the world since factories were shut down due to covid complications. This is the leading cause for the chip shortage, and the supplies for making chips and other electronics were not as present as they needed to be. Alongside this, it is also known that various companies are also experiences shortages on parts. This is especially relevant to Texas Instruments, who is a major distributor of parts for electrical circuitry. This means that we have be looking to make compromises in various parts of our design when necessary.

As the supply shortages happened to companies in the wake of covid-19, an upwards ripple caused shifts in the supply chain as consumers pressed for chips that were not available. This impacts us and our design as well, as later on when designing the PCB we must be careful to choose components which are not only compatible with our design, but actually in stock as well.

2.4 Solutions

Though the challenges presented above seem steep, we have a few solutions to these issues that we have implement during our project. For the most important aspect of the system, power output, we are going to be using a 20W solar panel as the primary source of power. As the power demands increase, a secondary hydro system will be turned on and will assist the solar panel. This allows for a stable power system to be achieved. Each hydro generator will be able to produce 10W. To be able to achieve the required power output, for the hydro system, two generators will be wired in series with each other. By doing this, we can produce the same amount of power as the solar panel but can keep costs down.

Another method of increasing efficiency is obtaining the correct submersible water pump with a water flow rating that maximizes the output of the hydro generators. According to the data sheet for the micro-hydro generator, we need a flow rate of 135 gallons per hour. Using a water pump, that will push 240 gallons per hour, will allow for two hydro generators to be run in series with each other. Although, some power loss will occur across the generators. This is due to the use of a splitter on the main water line. The cost of applying two water pumps would outweigh the loss of power. For this reason, it is recommended to use one water pump to provide water to both generators.

Monitoring a system is a key component of being able to maintain it. If we cannot get live accurate data, we have been unable to see problems as they come up. For this project, we have current and voltage sensing chips installed on the PCB. These chips will provide the essential data required to see the workings of the system. Each chip can look at both sides

of the system being the supply or source, and the load. From here we have then proceeded to have the software calculate the live wattage used by the system and the power supply to the load. This will give use a clear understanding of how efficient our system is. Although, we are not concerned with high efficiency, at this time, it will better for future improvements and a better understanding of how each energy conversion lowers the overall efficiency.

Once we have the supply and load data, we need a way to see the numbers. This led us to use wireless communications to send the data to a host website. From here the user can log into the website and check on the system at any given time. Since we have be using live data, the user will be given the most up to date information. One issue we thought about with this is security. To protect the data and the system, we have used an encrypted method of logging in. With the system secure, the user will not have to worry about their private data being leaked or the system getting hacked.

When trying to solve the range of the communication part, the best method was to create a mobile network. With a mobile spot, the system will be able to be at any location and will be able to send the data to the website. The only other choice would be to run extra feed wires from the source to the controller box. This would increase the possibility of a larger voltage drop. With an already small power capacity, we need to keep all voltage at the highest they can be. There will be some drop in voltage, but even the smallest amount could cause the system to perform poorly.

Finally, when it comes to issues regarding global chip and various electronic shortages, the simplest solution is to solve this by designing around the right set of constraints that we set. If possible, we should select the chip we have want to program for use and begin designing with it immediately. This means that we have need to identify early on what it is we require from a chip, we have been able to select from currently available inventories, which will be key in ordering a chip for our PCB. It will also help to ensure that we are doing the most research possible to pick the parts we would like to have with the fewest compromises made where possible.

Though it is certain compromises will be made, not all of them will be detrimental to us, and we may even find options that exceed our initial expectations. Comparing and contrasting our options properly will be a key component of our system design being as effective as possible as a whole package. From this, the sooner we can verify that a design will work, the sooner we can order the parts while they are still in stock, as stock inventories for the various chips and components will be subject to change very frequently. As the microprocessor and PCB are essential in our system safety and source switching regulation, they will be our priority for the beginning stages of our project.

3.0 Engineering Specifications

For our engineering requirements, we would like to be able to demonstrate two of our hardware requirements, and one of our software requirements. The key requirements we would like to meet first would be to generate 10 watts of power from the solar panels, have the system generate 240 GPH, switching to powering the load with the hydropower, and to have the system be able to send wireless updates to a separate device of our choosing. We choose these to be our demonstrable engineering specifications because these are some of the key features, we believe define our system.

3.0.1 Hardware requirements

1.0	The system shall have the ability to generate 10 watts of power from solar panels.
1.1	The system shall have the ability to pump at least 240 gallons per hour from the micro hydro-generator.
1.2	The system shall have the ability to charge a 7 amp-hour battery.
1.3	The system shall have the ability to control when the solar panel and the hydro-generator are operated.
1.4	The system shall be able to be remotely operated at a range of 25 meters.
1.5	The system shall conform to applicable safety standards.
1.6	The system shall have the ability to switch between generating power from solar panels and the hydro-generator within 5 minutes.
1.7	The system shall have the ability to engage both power generation sources simultaneously at a predetermined load power threshold (6 Watts).
1.8	The system shall be able to be implemented into pre-existing households within 2 hours.
1.9	The sensor's measuring power shall remain accurate within 0.2 Watts.

Table 1 Engineering hardware requirements

3.0.2 Software requirements

2.0	The program shall be able to transmit data to another device wirelessly every 30 seconds.
2.1	The program shall be able to read data from sensors at least every 10 seconds.
2.2	The program shall be able to manage data from the power generating sources within 0.2 watts.
2.3	The program shall be able to adjust where the power is outputting based on energy demands within 1 minute.
2.4	The program shall be able to shut down parts of the system manually upon reaching unsafe levels and thresholds within 20 seconds.

Table 2 Engineering software requirements

3.0.3 Key specifications

For our key specifications, we have a table which contains the most important things we want our system to do. These will be the main features that guide our senior design project through to the end, and the criteria that we have been striving to meet as an absolute baseline. This allows us to focus on three key features of our system, while still being able to have stretch goals and other things we would like our system to do. The key specs can be seen in the table below.

3.0	The system will be able to generate 1W of power every 6 minutes.
3.1	The program will be able to wirelessly send data to a website every 30 seconds.
3.2	The system shall be able to switch which source it runs the load from between the solar panels and the hydropower within 45 seconds.

3.1 House of quality (HoQ)

The figure below shows us the house of quality. This chart shows the relationship between the major categories pertaining to the engineering specifications and the market specifications. In our two-cycle power system, the relationships and impacts of each requirement can be seen in reference to each other through the legend presented in the top left corner.

A house of quality is important, as it shows us how aspects of our design will intertwine with each other when we consider them in tandem. It is inevitable that parts of the system will interact with each other even when they seem like they are two separate parts of the system. Designing the house of quality was very helpful in determining what features we really found to be more important than others.

Due to the nature of our senior design project, there are no viable two-cycle power systems that consist of solar and micro-hydroelectricity, which means we do not have a frame of reference for what competitors' priorities and level of quality is for comparison. Though there are other larger scale systems that exist in other countries, these applications and implementations are not comparable to our implementation due to the scale of both systems being very different.

In our house of quality, we can see the three targets we would like to demo highlighted in green. For our target deliverables, we have chosen the total output power of 25W to be our first deliverable. Having the cost of our total system build will be another, with our goal to keep our project implementation below \$600. Finally, we wish to have a way to wirelessly transmit the information to a database which can be displayed on a website, and we would like this information to be updated every 3 seconds at worst. This will allow us to transmit a constant stream of accurate data.

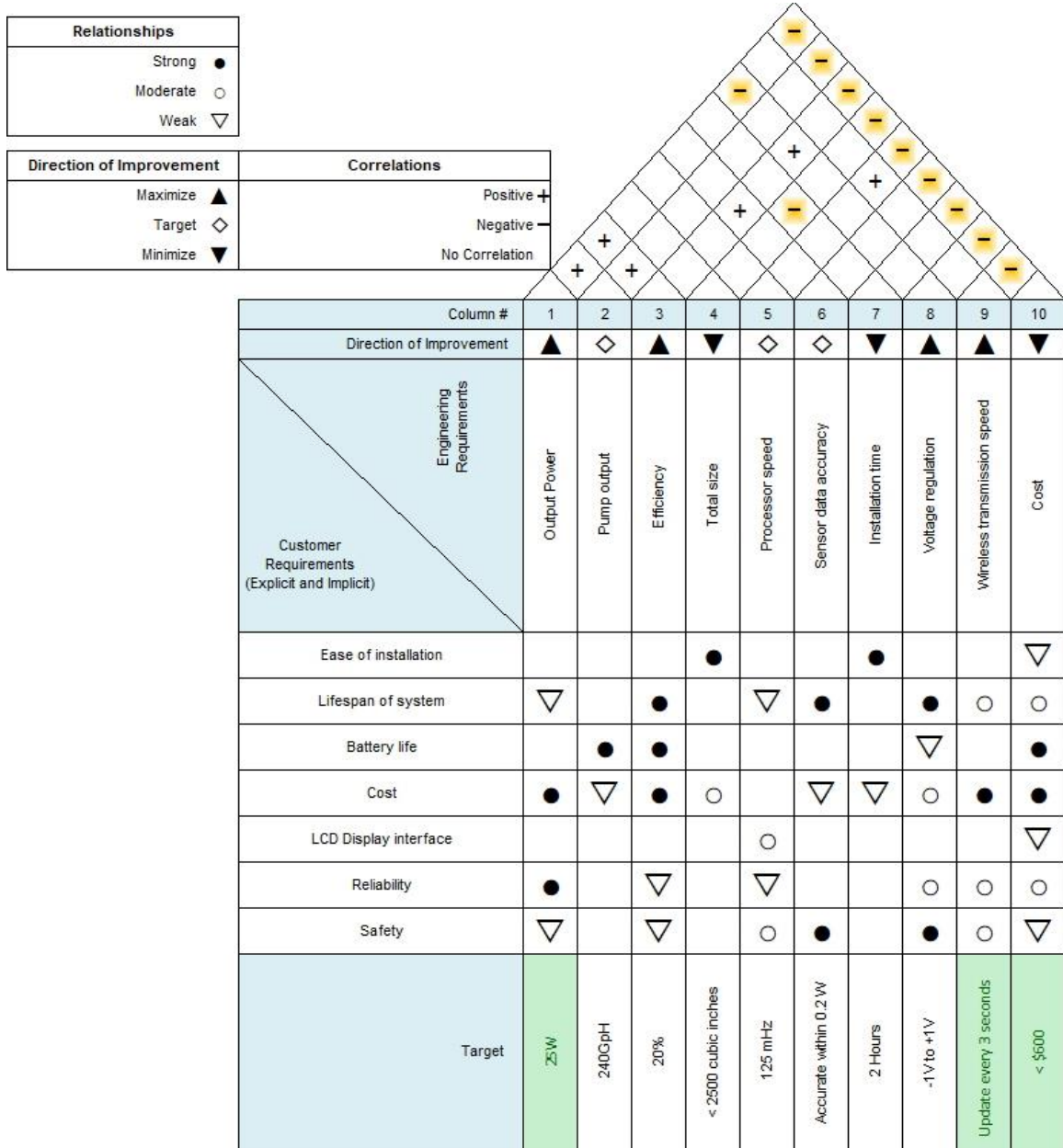

Table 3 House of quality

3.2 Block Diagrams

Block diagrams have an impact on the design process. They allow the engineers to keep the focus on the design and the potential end results in mind. They also help in the troubleshooting process if anything goes wrong during the design process. Being able to quickly pinpoint which section of the design, will help with getting issues fixed in a timely manner and can improve the time in which it takes to complete a prototype. In this section we have present the current diagrams of our design.

3.2.1 Hardware Flow Diagram

In the figure below, we can see the initial design for our two-cycle power system. Included in this design are various sensors that will be used to help create a robust set of data that we have be able to provide to the user of the system, as well as various other safety features such as a relay and a battery charge regulator which will allow us to ensure safety is a top priority. As we further develop the project, this will be subject to change as we realize more and more realistic designs for our system. Note that the PCB design block is disconnected from the rest of the system as it is not within the flowchart.

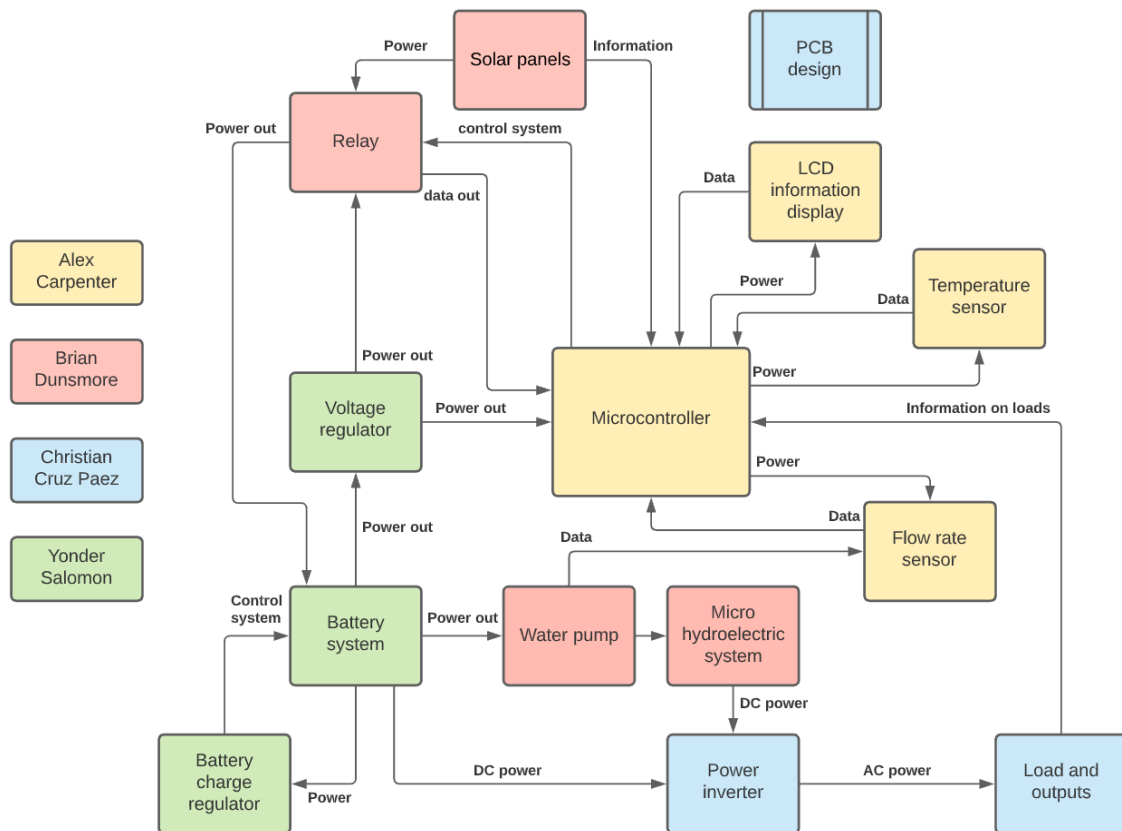

Figure 1 System power flow diagram

3.2.2 Software Flow Diagram

As was the case for the hardware flow diagram, we can see here the software flow diagram. This diagram mainly shows how the control system we implement will make decisions on what part of the system will be used to operate the load.

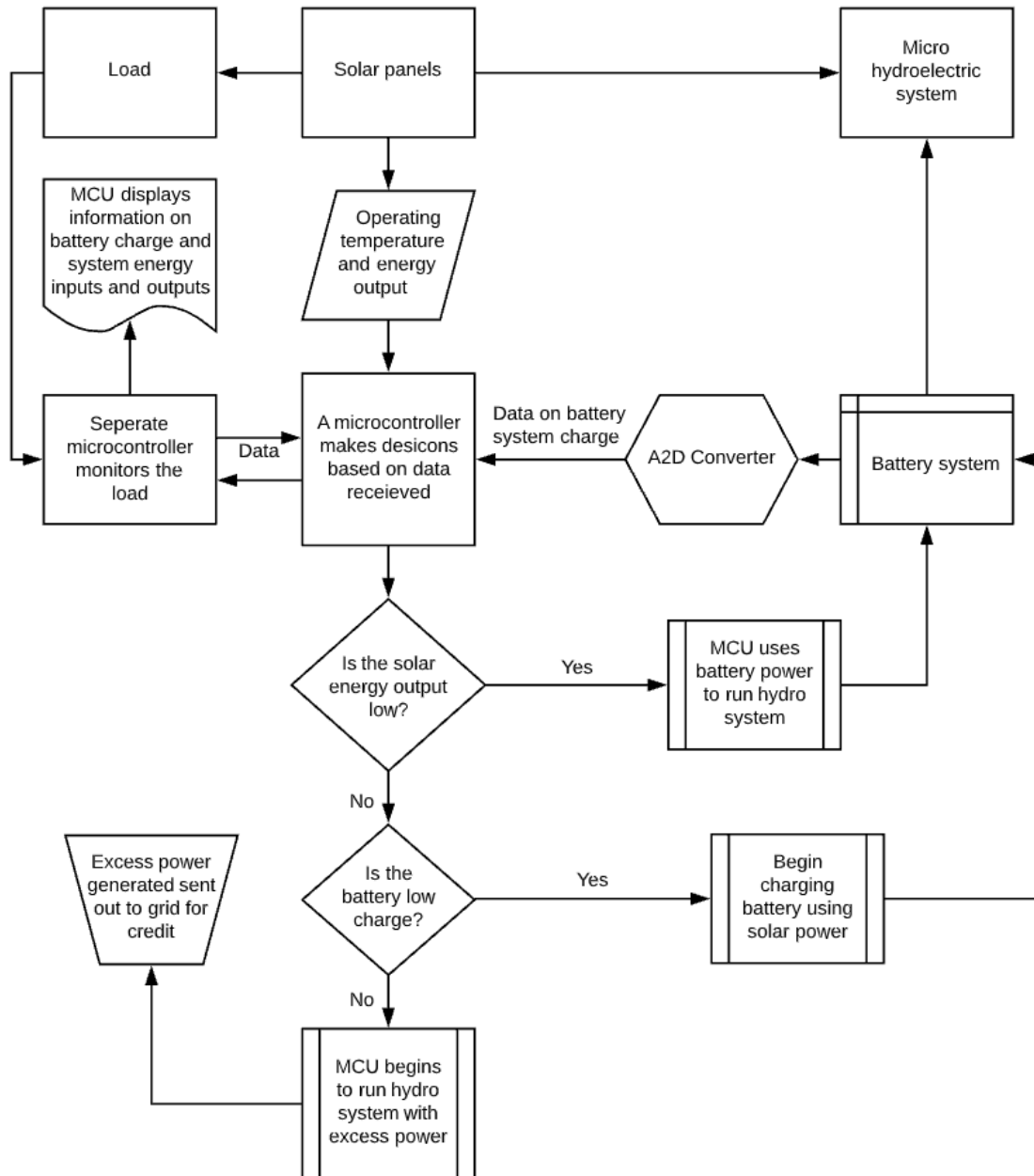

Figure 2: Software component flowchart

3.2.3 System Operations Under Normal Conditions

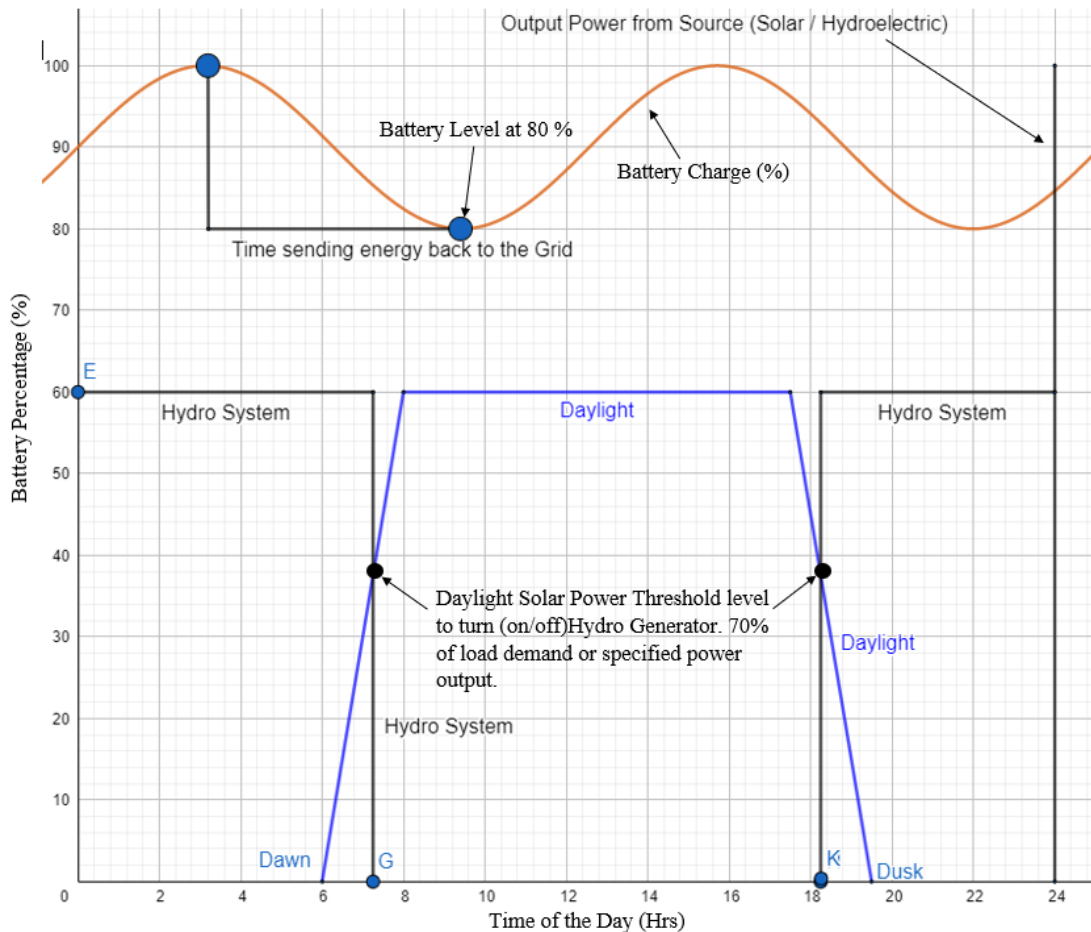

Figure 3: System output under normalized conditions

The above figure shows the intended behavior of our 2-cycle power system. It is the intent to set up a certain threshold on the battery charging patterns to only charge the battery when it is below a certain point in charge levels. This threshold will be determined based on the type of battery used in order to preserve the battery usable life and contingent on live data regarding the load demands present.

The power input for our system varies upon the time of the day and available resources. As shown on the graph, past a certain time during early morning late afternoon the system shall automatically switch from one primary source to the other in order to cover the load demand and satisfy the battery needs.

While this graph only covers the ideal conditions of operations, i.e.: no unexpected outage from any of the two systems, it is plausible that there will be the need to run the hydro system during a period of expected solar power input. Some examples of reasons may be in the form of weather related or part malfunctioning. Weather related instances are the main problem we have face in the efficiency of the system. It is hard to determine when the weather will allow for the panel to operate, or for how long it will be out of service. With this in mind, we want the system to switch power responsibilities without much of an interruption. The main processor will take certain variables into consideration in order to

determine the needs of the system at that given point. The best metric in place to determine how many sources and to what extent it is to be used is the battery charge level in addition to any manual overrides.

4.0 Research and Part Selection

After the design format is completed, the next step is to research individual parts. Each selected part is a key component in getting a working prototype. Each part must be thoroughly researched and then the ones that are selected must have meet the criteria of the other ones. If parts are selected that will not work with each other will prolong the design process and increase the cost of the project. As will most projects, quality, schedule, and budget, are the three most important steps. Carefully researching and selecting the correct components will meeting all three requirements in the overall project design.

4.1 Solar Panels

As the main component of our two-cycle power system, it is key that we find panels that can meet the power output while staying within budget restraints. For our design, the target output will be 20W. From here will be able to set thresholds for the system to manage. With the target output required, we selected the topsolar 20W solar panel. This panel comes with many features that will assist in the overall make-up of our design. One key feature is the monocrystalline cells that give the panel a 23 percent overall efficiency rating.

Because efficiency is already one of the main challenges of the design. We decided to seek a panel that would help in raising the overall efficiency even by the smallest amount. Other panels that were viewed had an efficiency rating of 15 to 19 percent. Another key component was the voltage output. This panel produces a 12V output, making it ideal for our design. For the hydro system to operate, we needed a power supply of 12V DC. Also, to match with the rechargeable battery.

Other than the output requirements, there were many other features that made us select this panel. One of these features is the make of the panel itself. Each topsolar panel is made with an aluminum frame. This gives the panel a sturdy base and provides protection for some outside hazards. Along with the frame, the solar cells are protected by a low iron-tempered glass. Without any protection, or even a weaker one, the cells could become damaged. This would lower the efficiency, or even short out the panel. Making the completed system unable to perform the duties we assign it to.

Another form of protection is the EVA film that is used on the front and back of the cells. This eliminates water and wind from damaging the cells. The last line of protection for this panel is the TPT back sheet. Heat is the number one reason why solar panels cannot make the expected life span. This back sheet allows for proper cooling of the cells, while keeping outside hazards out of the system. With all the protection components in place, the panel can be used outdoors for more than 10 years.

The last feature, that aided in deciding on this panel, is the mounting adjustability. Each geographical location can lower the power rating of a solar panel. With the ability to change the angel of the panel, we can always allow for the most optimal position for solar generation. This means, we can tilt the panel along a 180-degree axis. Therefore, increasing the efficiency of the system. Also, we can mount the panel on any surface, or structure. Using the pre-drilled holes, the topsolar panel is quickly, but securely, mounted.

Two similar panels were also researched. Each one had some of the same features as the one selected. Price of the panels was different on each one. The topsolar panel was not the

lowest price. However, it was the most efficient solar to energy conversion rating. With the system already having a lower efficiency rating, it was better to pick a part that would help in improving this rating. Even with the price increase the output increase outweighed the cost. Overall, the topsolar panel provides us with the required power, voltage and efficiency. Along with the other added features. This makes it the clear choice from other panels of this size on the market. The details for this panel can be seen in the figure below.

Model Number	TS-S20M
Maximum Power-Pmax(Wp)	20W
Voltage at Maximum Power-Vmp(V)	18.2V
Current at Maximum Power-Imp(A)	1.1A
Open Circuit Voltage-Voc(V)	22V
Short Circuit Current-Isc(A)	1.21A
Power Tolerance	0/+3
NOCT*	45±2°C
Temperature Coefficient of Pmax	-0.40/°C
Temperature Coefficient of Voc	-0.31/°C
Temperature Coefficient of Isc	0.04/°C
Operating Temperature	-40°C to +85°C
Maximum series fuse rating	15A
Maximum system voltage	600V DC
Construction	Tempered glass,Silicon cell,EVA,Backsheet
Solar Cells	Monocrystalline,36cells(156*156mm)
Front Glass	Low Iron,High transmission 3.2mm glass
Encapsulant	EVA(Double layers)
Frame	Anodized Aluminum Alloy
Junction Box	IP67 Rated
Diodes	By-pass diodes
Dimensions	485*350*25mm
Weight	2.3kg
Output Cables	2*1mm ² ,450mm

Figure 4: Solar panel specifications

4.2 Micro-hydro Generators

For our secondary source of power, we have been using two micro-hydro generators. Each generator will be able to produce up to 10W of power. In order to achieve the same power rating as the solar panel, the generators will be wired in series. The generators we choose to use are Diyarts 10W micro-hydro 12V. Each generator uses a neodymium magnet to enhance its power generation capacity. To improve efficiency, the generator has two components that make this type the perfect choice. First, it uses a larger scroll impeller. This allows for a larger rotation of the magnet. Therefore, improving both the power output and the overall efficiency. Most generators lose efficiency during start up. For this generator, the design allows for a low water pressure start up. Meaning it will begin producing energy at 0.5 Mpa of water. For added protection, and efficiency, bearings are placed around the rotating parts of the shaft. Without the bearing, power loss would be increased due to friction from rotation.

The Diyarts generators are unique in their design. First, is the size, 4.02x2.95x1.89 inches and weighing 1.1 pounds. This generator is small and can fit into any housing unit. For this project, we choose to mount each generator inside the housing for the water. By doing this, we can eliminate aeration inside the water lines. Having air inside the water line will decrease the power output. Another unique feature of the generator is the noise level produced during operation. Mechanical noise created by the generator could become a nuisance to anyone that is in the area for any period. The <55dB noise level makes this generator run at a quiet speed. Lastly, is the life of the generator. This type has a manufacturer lifespan of 3000 hours or more.

With both generators working together, this system should be able to assist in the power demand at a fast rate. Also, along with the durability of the housing unit, and the generation lifespan. We should be able to run the generator with little worry of failure. Because this system is being developed for a personal home. The smaller size of the generator and the low mechanical sound rating will be appealing to most customers. With all the advantages we have, this generator is best choice among the others that were considered.

Technical conditions

The output voltage	12V	the maximum pressure	0.6Mpa outlet closed
The maximum output	≥220mA (12V)	outlet opening max pressure	1.2Mpa
between the wire resistance	10.5 ± 0.5Ω	Start pressure	0.05Mpa
Insulation resistance	10MΩ (DC100)		

The mechanical properties and the operating environment

Appearance	generator surface clean , no rust, no scratches when significant , solid structure .	the amount of the Generator	90g around
axial clearance	0.2-1.0mm	generator life	≥3000h
mechanical noise	≤55dB	Output characteristics	the output voltage with no voltage regulator is proportional to the water pressure.

Figure 5: Hydro generator specifications

Each micro-hydroelectric generator that was researched had the same specifications. It was difficult to show a clear difference between all three that were initially selected. Even to the point that one could be replaced with another and there would not be a difference in performance of the system. When it came to selecting the generator, one aspect that helped in the process was peer to peer reviews. These reviews gave us an insight to the actual performance of each manufacturer's product. With this insight, it became a clear choice that the Divart generator was the better choice for our design.

4.3 Hydro Pumps

For the micro-hydro generators to be able to support the system, a proper amount of water flow must be established. The amount of water flowing across the generator will determine the amount of power created. For this design to increase the efficiency of the generators, the water pump must be able to put out a minimum of 135 GPH (gallons per hour). With this flow rating we can achieve the 10W max from each of the hydro generators. Therefore, we decided on the AEO DC water pump. This pump is designed to work with solar panels and batteries as its source of power. Because the pump has a voltage range, 12-24V, it can run without harm if the solar panel begins to put out extra voltage. One of the recommendations is to run the pump on the battery. This helps to keep the source voltage at a constant rate, no matter what the solar panel does.

Power consumption is a focal point for the pump. Because we are using the system to power the pump, knowing the amount of power to run the pump will aid in making sure we don't overload the system while generating with the hydro system. From the data sheet, provided by the manufacturer, we can see that the power consumption is 5W at the 12V rating. One thought was to run the pump at the max 24V. However, by doing so we see that power consumption is increased by a drastic amount. This would cause the system to fail, or the solar panel could not be able to support the pump.

Two different methods of connecting the generator's water flow have been discussed. One method is to connect the hoses in a continuous path. Using this method, we could have a circular pattern of water. This will aid in keeping air from getting into the system. There is a drawback with this method. Until further testing is completed, we have been unable to see if the flow through the second pump. Although the water pump will produce 240 GPH, the outlet flow from the first generator will be lower than the pump output.

The second design is to use a splitter and connect each generator to the pump directly. Using this method, we can ensure that the flow to the second generator will remain at a constant rate. However, there is another drawback to this method. Using this method, could result in lower the flow to each generator. Earlier testing, using a 63 GPH pump, showed that the generator would produce 5.9 volts. Assuming if we doubled the flow rate, we should be able to produce enough voltage to get close to the max output. If the splitter splits the water flow equally, then we have still been above the required flow rating needed.

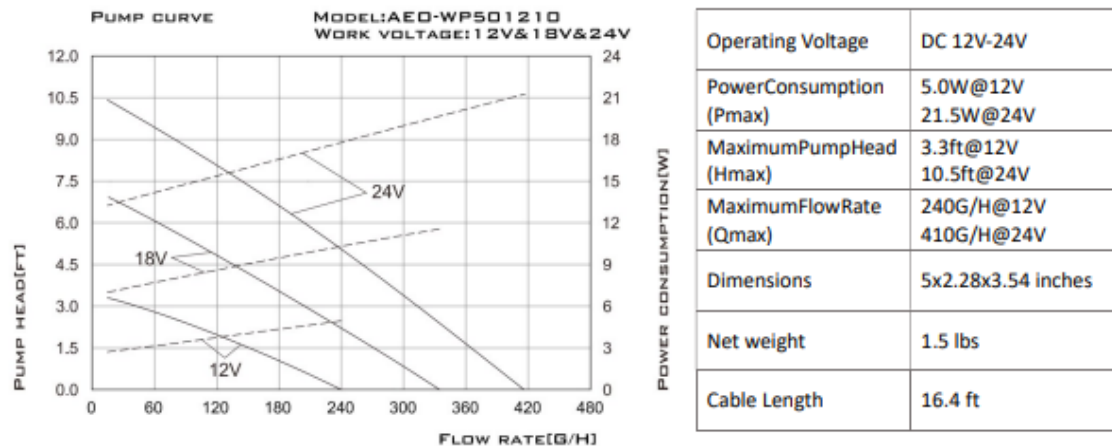

Figure 6: Hydro pump operating specifications

Further research was done and discovered that 126 GPH would be enough to produce the closest voltage required to get the full wattage out of each generator. In order to keep cost down, it was decided to use a 240 GPH pump, made by AED. With the addition of the splitter, we can achieve a close enough voltage that would allow the generators to produce 10 watts each of power. Although, knowing there will be some loss in energy, due to the conversion of energies, with this type of generator we have get the desired results we are expecting out of this design.

4.4 Relays

An electrical relay is a device that can electrically separate two parts of a circuit. They are often used when there is a high current circuit that needs to be separated from a low current circuit via switch. Relays are typically used in solar systems to disconnect the entire system from the loads and outputs, which can be useful for disconnecting the solar system from the main power grid. In our case, we have been using two relays.

The first relay will be directly connected to the solar panel at the very start of our design. This relay will be used to aid in the process of switching the power input from depending on the solar panels in our system to letting the battery and pump combination be the primary source of power. Speaking on this design, it is essential to have some form of switching control in our two-cycle power system and the relay will help us do just that. The second relay we have be using will be at the end of the circuit, which is going to be isolating our loads from the rest of the circuit. We are doing this for safety reasons, so that at any point of critical system failure the relay can trigger and cut off the power to the loads from the main circuit. For our experiment, we have been using the HiLetgo 12V 1 channel relay, as this is all we need for both relay applications.

4.5 Voltage regulator

Voltage regulators can be found everywhere in the world where electricity is present. This is because they play a big part in keeping electrical systems safe. The voltage regulator is a system designed to automatically maintain a constant voltage. The system helps to regulate voltage during large changes in power generation and in load fluctuation, which

is most often performed by taking in a larger voltage and letting out a more consistently streamed output voltage. In this case, we have to be using an active voltage regulator to supply a steady and constant stream of voltage to our microcontroller from our battery. Voltage regulators can range from anywhere between 1V to over 30V, and can come in two major types, linear and switching regulators. With each having their own advantages and disadvantages, we must compare them to get a realistic assessment for which is needed.

4.5.1 Linear voltage regulators

A linear regulator is a transistor-based device packaged as an IC, mainly composed of differential amplifiers. It is typically used in circuits where the load and input being regulated are linear devices, and all linear voltage regulators require the input voltage at a minimum higher than the output voltage in order to function properly. In their most basic forms, we can look at two different classes of linear voltage regulators, which can become candidates for an applicable voltage regulator for our system, being shunt and series regulators.

Shunt regulators work by providing a path from supply voltage to ground using a simple variable resistor. The current gets diverted from the load and flows to ground, which makes this the less efficient form of linear regulator. This type of linear regulator leads to being simpler in design usually, which makes it cheaper. It is most commonly used in very low-powered circuits, because these regulators can only absorb current, and in these cases the current that is lost is very small and negligible.

On the other hand, we have the series regulator. This type of linear voltage regulator is more common than shunt regulators because of its more efficient design and output. This type of implementation works by providing a path from supply voltage to load through a transistor instead of a resistor. This allows the device to be more efficient and undergo less stress than their shunt counterpart. The best case of this implementation is the low dropout voltage regulator, which continues to properly regulate voltage even as the input voltage becomes very close to being what the output voltage is.

4.5.2 Switching voltage regulators

On the other hand, we have switching voltage regulators. These toggle on or off at higher frequency and allow us to vary the duty cycle of the output voltage. These devices use power switches, inductors, and diodes to transfer energy. The power switch is turned on and off by an IC switching controller. This allows it to maintain a constant output voltage and gives us a much higher efficiency. We can also do this with much less heat generated which in turn makes heat management easier, and also much more controller over our regulator. However, this will lead us to switching regulators being more expensive devices over their linear counterparts. They are also more complex and require more care when designing around and require more external parts.

Through the use of this type of regulator we gain access to more complex topology, such as the buck and boost converters that are common in power systems. Boost converters are topologies involving switching regulators that are capable of stepping up an input voltage to make it higher. Conversely, the buck converter is used to step down a voltage input to a lower regulated level. These types of converters can even be used to transfer through a

transformer to provide isolation with respect to the input. An issue arises as these types of regulators cause noise to be added through the system, which would not happen to us with a linear regulator.

4.5.3 Comparison and part selection

After taking a look at both types of voltage regulators, we can see benefits and drawbacks on each side. Linear voltage regulators are cheaper, simpler in design, respond quickly to changes in voltage, and do not produce switching noise. However, with the switching regulator, we have the benefit of higher efficiency and better performance, with an increased price tag and some noise.

Due to this, we have been using a linear voltage regulator in our system. This will ensure that we get a consistent stream of voltage with little variation in our output power, regardless of power generated by the solar system and charge being dispersed into the system by our battery. The linear voltage regulator we have been using is a packaged IC known as the 7805, which needs little to no description. As a very widely used voltage regulator, it is simply the best choice for our design, and will ensure we get our voltage down to a maximum of 5V with a tolerance of 2% for our microcontroller's input power along with being easy to implement.

PARAMETER	TEST CONDITIONS	T _J †	μA7805C			UNIT
			MIN	TYP	MAX	
Output voltage	I _O = 5 mA to 1 A, V _I = 7 V to 20 V, P _D ≤ 15 W	25°C	4.8	5	5.2	V
		0°C to 125°C	4.75		5.25	
Input voltage regulation	V _I = 7 V to 25 V	25°C	3		100	mV
	V _I = 8 V to 12 V		1		50	
Ripple rejection	V _I = 8 V to 18 V, f = 120 Hz	0°C to 125°C	62	78		dB
Output voltage regulation	I _O = 5 mA to 1.5 A	25°C	15		100	mV
	I _O = 250 mA to 750 mA		5		50	
Output resistance	f = 1 kHz	0°C to 125°C	0.017			Ω
Temperature coefficient of output voltage	I _O = 5 mA	0°C to 125°C	-1.1			mV/°C
Output noise voltage	f = 10 Hz to 100 kHz	25°C	40			μV
Dropout voltage	I _O = 1 A	25°C	2			V
Bias current		25°C	4.2	8		mA
Bias current change	V _I = 7 V to 25 V	0°C to 125°C			1.3	mA
	I _O = 5 mA to 1 A				0.5	
Short-circuit output current		25°C	750			mA
Peak output current		25°C	2.2			A

Table 4: Voltage regulator specifications

4.6 Batteries

As is the case with almost all electronics and electrical systems in our world, we require a battery for our two-cycle power system. From cars to smartphones to flashlights, battery systems can vary wildly based on what is needed for the specific system we are looking at. Because of this, we must go through the process of breaking down which one is the correct choice for our project.

Batteries are most broadly split into two categories, being primary and secondary batteries. Primary batteries are the types of batteries that once their charge has been used, they cannot be recharged and reused, and instead must be disposed of. These batteries are typically seen in devices such as remote controls, children's toys, and smoke detectors. These batteries typically contain a single-use galvanic cell with an irreversible chemical reaction, so we cannot reverse this chemical process to be able to use the electricity generated by the battery again.

Secondary batteries are the types of batteries which, unlike primary batteries, can be recharged upon depleting. This makes them useful for long term applications and heavy usage. This would apply to our system as well and is the type of battery we have been choosing between the two types of batteries.

Amongst the secondary battery family, there are different ways of storing and recharging the chemical energy contained within each battery. Each battery has a different chemical makeup and use case, meaning it is important to distinguish why each battery would be useful for our system or why they may not be. Amongst the batteries we considered were the lithium ion, nickel metal hydride, lead acid, redox reflow, and zinc ion battery systems.

4.6.1 Lithium-ion Battery

Lithium-ion batteries are improving in technology at a fast rate. With these types of batteries, there comes some characteristic advantages and disadvantages. In order to make the correct choice, we closely looked at all the way a lithium battery will help improve the system overall. The first major characteristic is that lithium batteries have a high energy density. For our system, we need the battery to be able to supply enough power for a full twelve-hour cycle. This time frame will also depend on the time of year. During daylight savings, the battery will need to supply power for a shorter time period. Having a battery that can supply power for a longer period of time is ideal.

The next two characteristics are self-discharging and low maintenance. Low maintenance allows the battery to operate, without the worry of losing performance. This is more applying to the customer. As many people will want a system that will work, without them needing to perform any task to maintain it. Because we are using rechargeable batteries, the rate at which the battery will discharge is a key component. For lithium batteries the discharge rate is lower than other batteries on the market, five percent in the first four hours, and a flat line of one to two percent a month.

The last major characteristic we looked at was the cell voltage of the battery. This factor allows us to get a more powerful battery without sacrificing space. Because lithium batteries have a cell voltage of 3.6 volts. It will require less cells to meet the voltage demand we need. Standard batteries have a cell voltage of 1.5 to 2 volts. Making the size of the battery much larger. Another advantage of the higher cell voltage is it simplifies power

management of a system. Other advantages of a smaller priority are load characteristics, no priming, and largely available.

With all the pros of a lithium battery, there are some cons to them as well. One that needs to be mentioned is that lithium batteries need to be protected. Because of the smaller size of the battery, lithium batteries require protection from charging and discharging. Over current is a major damaging problem for these types of batteries. In order to keep them working properly, many lithium batteries need a battery management system installed. This allows for proper charging, without overcharging the cells. Without a management system installed, excessive voltage can damage the cell. When each cell is producing extra voltage, during the charging sequence, then the temperature of the battery is increased. Range of the operating temperature should not exceed one to two degree Celsius.

Aging is another con of a lithium battery. In a lithium battery aging can happen whether the batter is in use or not. Added to this factor, aging will be increased with each charging period of the battery. Often, batteries can withstand a large amount of charging cycles. Between 500 and 1000, is the standard number of times the battery can be charged. Knowing that number of times charged, we can set up a routine schedule to replace the battery. However, with the need to replace the battery at a calendar set date, this will increase the cost of the system. Also, add in that lithium batteries cost around forty percent more than an average battery, this makes cost a major disadvantage.

Items		Specifications	Notes
5.1	Rated Capacity (Minimum)	3200mAh	0.65A discharge at 20°C
5.2	Nominal Capacity (Minimum)	3250mAh	0.65A discharge at 25°C
5.3	Nominal Capacity (Typical)	3350mAh	Reference only
5.4	Nominal Voltage	3.6V	0.65A discharge
5.5	Discharging End Voltage	2.5V	
5.6	Charging Current (Std.)	1.62A	
5.7	Charging Voltage	4.20 ± 0.03V	
5.8	Charging Time (Std.)	4.0 hours	
5.9	Continuous Discharging Current (Max.) ^{#1}	4.87A	0 ~ +40°C
5.10	Internal Resistance	less than 100mΩ	AC Impedance 1 kHz
5.11	Weight	less than 48.5g	
5.12	Operating Temperature	Charge	0 ~ +40°C
		Discharge	-20 ~ +60°C
5.13	Storing Conditions	less than 1 month	-20 ~ +50°C
		less than 3 months	-20 ~ + 45°C
		less than 1 year	-20 ~ + 20°C
		Percentage of recoverable capacity 80% ^{#2}	

Table 5:Lithium-ion battery specifications

4.6.2 Nickel Metal Hydride Battery

Nickel metal hydride batteries have been in use since about the 1970's, where development began in the Battelle-Geneva research center. These types of batteries are typically a replacement for similarly shaped alkaline batteries which cannot be recharged. The types of batteries had been designed as a replacement for the nickel cadmium battery, which is

no longer in use. This is because the nickel cadmium batteries were toxic when punctured and were also dangerous to the environment, so we have not been going over them.

Nickel metal hydride batteries are high current cell batteries. This makes them good for applications where smaller, yet high drain devices are in use, such as digital cameras, cellphones, portable consoles, laptops, and so forth. This is an implementation that cannot be handled by a battery such as a lithium-ion battery, as the low internal resistance of the nickel metal hydride battery is key in making this possible. As such, these types of batteries will do well with outputting a large amount of energy to devices that need it, but much like the other batteries it has its drawbacks.

When considering not just our implementation of a battery in this project, we run into a few key issues. Though there exist full battery banks made of nickel metal hydride batteries which we could use in our power system, these kinds of batteries do not do well in long term use. This is because the nickel metal hydride battery suffers compared to its competitors in a few key aspects. First, the nickel metal hydride battery has a very high self-discharge rate and can discharge to a very low voltage over a short period of time. Though this is seen throughout all cells in the battery world, this is a very particular problem with the nickel metal hydride battery.

This, coupled with their relatively long charge time compared to its competition does not help this type of battery compete in today's world. When looking at this type of battery, we can also see that nickel metal hydride batteries have a complex charging algorithm as well. This means it is harder to create a system in which the battery and the energy conversion process are monitored by a system to ensure the most efficient charging possible. This means that alongside discharging rather quickly, even recharging the battery is complicated. On top of this, when in use this battery system has the potential to generate a lot of heat, much more than other types of batteries. All of these issues lead to this type of battery not being useful in our power system.

Diameter		33.0 +0 / -1.0 mm	
Height		91.0 +0 / -1.5 mm	
Approximate Weight		300g	
Nominal Voltage		1.2V	
Discharge*1 Capacity	Average*2	11300 mAh	
	Rated (min.)	11000 mAh	
Approx. Internal Impedance at 1000Hz at charged state.		5 mΩ	
Charge	Standard	1100 mA X 16 hrs.	
	Rapid*3	5500 mA X 2.4 hrs.	
	Low rate	550 mA X 32 hrs. 367 mA X 48 hrs.	
Ambient Temperature	Charge	Low rate	-30 °C to 75 °C
		Standard	
		Rapid	
	Discharge		-40 °C to 85 °C
Storage	<1 year	-20 °C to 35 °C	
	<6 months	-20 °C to 45 °C	
	<1 month	-20 °C to 55 °C	
	<1 week	-20 °C to 65 °C	

*1 After charging at 0.1 It for 16 hours, discharging at 0.2 It

*2 For reference only.

*3 Need specially designed control system. Please contact Panasonic for details.

Table 6: Nickel metal Hydride battery specifications

4.6.3 Lead Acid Battery

Lead acid batteries are also an extremely common type of battery. They have been used in the automobile, and other applications, for over 150 years. This type of battery is the most well-known kind. Because of the time they have been around, lead acid batteries can be quickly manufactured and have a low cost. A large draw to this battery is the high current capacity. This means that starting a motor, or the water pump in our case, makes this battery a good choice for consideration.

Another pro to this battery is its ability to tolerate abuse. Lead acid batteries are made to withstand all types of abuse. Abuse can range from heat to physical damage. With its plastic shell, there is little worry about damaging the individual cells. In batteries overcharging is normally a major issue. However, a lead acid battery can withstand overcharging of the battery. It's able to do this, because of how the cells are aligned. Since the lead acid battery has been around for many years, the technology has been able to improve as well. This is the main reason why the battery is able to handle more stress and gives it a popular outcome.

Although the lead acid battery has many appealing properties, it is not without its own disadvantages. One major flaw is the lifespan of the battery. Where other batteries can have up to 1000 charging cycles, the lead acid is limited to 500. In the long run, more batteries

will be needed for a sustained system. This has something to do with large crystals that can form on the negative plates. From here the voltage output is lowered, and once it gets to a set level the battery will no longer be able to provide the proper amount of energy. Also, these crystals affect the charging capability of the battery. From the beginning of the lifespan, a lead acid battery only has a charging efficiency of seventy percent. When crystallization happens, this efficiency will lower. Causing all the above effects to take shape and decrease the efficiency of the battery.

Environmental concerns arise in a lead acid battery. These batteries use a corrosive electrolyte liquid, which can burn a person or corrode metal. This makes it to where we would need to monitor the battery itself for possible leaks. Lead acid can be harmful to the environment. Once, the battery has reached its lifespan and needs to be replaced. The battery must be disposed of in a proper manner. This is due to the harmful effect it can have on the environment.

Lastly, the lead acid battery has two other disadvantages. One of these is that it cannot be used in a variety of orientations. This means that there is only a certain number of designs make ups that can occur. The other is how the battery must be stored. Due to the nature of the battery, it must be stored in a charged state. Creating an unsafe area, as a charge battery can cause a fire, if a short was to happen.

4.6.4 Redox Flow Battery

In recent years, redox-flow batteries have become more commercialized in a containerized size. Most of the applications for this type of battery are from a medium to large scaling factor. Two of the best characteristics of a redox flow battery are decoupled energy and the power capacity. Energy is stored in the electroactive material present in the electrolyte, while the output is based on the number and size of the electrodes. The more electrolyte stacks there are, the higher the output power will become. Redox flow batteries come in all ranges of sizes of 10 to 200 cells. With this cell make up the energy storage of the battery and the power output can be separated. Where the power output is by the number of cells, the energy storage is determined by the concentration and volume of the electrolyte material.

This type of battery has many advantages. Two of the best ones, on the customer side, is the long life and amount of charging times of the battery. Redox batteries are known to last for over 20 years and have a cycle life of 20,000 to 25,000 cycles. This would pair great with a system that cannot be accessed very easily or doesn't require much maintenance already. Main reason for the long life is the fact that redox batteries have no phase changes and use a durable membrane technology.

Charging and discharging of a battery is a common place where damages to a battery occur. However, with the voltage remaining constant throughout the charging and discharging times. This will reduce any damage that will happen during this time. Another characteristic about charging a redox battery, is that it can be charged and discharged at any rate. Unlike other battery types, there has to be a certain voltage and current rating for charging to begin. Although it can be charged at any rate, one thing that needs to be watched is the overcharging.

The last advantage of a redox battery is the cost and cost per kilowatt hour. One note, the cost is based on an industrial standard. For a personal use, the battery cost would be at a much higher cost. According to recent market studies, the redox battery is labeled as a low levelized cost of storage. Combined with the long life of the battery, it has become the best suitable choice for energy storage.

One note about the battery is the cost per kilowatt decreased as the storage capacity increases. This means that the larger the storage ability, the less is the cost to discharge the power output. Another reason the cost is lower, is the size of the battery. With the storage capacity being high, it would be assumed that the size of the battery would be large as well. However, the size of the redox battery is smaller than a standard lead acid battery.

According to a study done by the University of Southampton, the only recorded disadvantage is its new technology. Under normal circumstances newer technology comes with unforeseen issues. Until the battery has been used in many different applications, we have not be able to determine how many disadvantages the battery system will have.

Table 6
Outline specification planned for the Regenesys[®] energy storage plant at Little Barford, UK [10]

Overall plant parameters	
Maximum rated power output	15 MW
Energy storage capacity	120 MW h
Discharge duty cycle	10 h
Design turnaround efficiency	60–65%
Predicted lifetime	>15 years
Site area	<3000 m ²
Design availability	95%
Power conservation system	
Power rating	15 MW, 18 MVA
Design response time	<100 ms
dc link operating voltage	±2400 V
Design ramp rate	+15 to –15 MW in <100 ms
Inverter ac output voltage	6600 V
Cell parameters	
Membrane	Nafion [®] cationic
Nominal cell voltage	1.5 V
Electrode area	0.67 m ²
Electrolytes	NaBr and NaS (15 m ³ of each per MW h)
XL module	
Typical number of cells perm stack	200
Nominal discharge power rating	100 kW
Operating voltage range	150–360 V
Module open circuit voltage	300 V
Module layout	
Total number of XL modular stacks	120
Number of stacks in electrical series	12 (each string)
Number of parallel strings	10

Table 7: Redox flow battery specifications

4.6.5 Zinc-ion Battery

Zinc-ion battery technology is a relatively new form of battery. It is a recently created product in the market to fit a gap between lithium-ion batteries and lead acid batteries. The zinc-ion battery has a combination of favorable aspects from both lithium-ion batteries and

lead acid batteries, with a few major factors preventing it from being the king of the battery world. Zinc-ion batteries are in the same family as lithium-ion batteries but provide the benefit of being able to withstand harsh operating environments over long periods of discharging time.

The zinc-ion battery also has a benefit in its chemical construction because the zinc-ion battery has a water-based electrolyte, which prevents the battery from catching fire. This makes the battery system within the zinc-ion battery much safer than lithium-ion batteries because lithium has the potential to react violently around other chemicals and elements, mainly due to the use of a flammable electrolyte. The zinc-ion battery is also composed of materials such as zinc and manganese, which are much cheaper and more commonplace and can be mined within America. This is in contrast to the lithium-ion battery, which uses lithium cobalt and nickel, which are both more expensive and more difficult to get a hold of.

Another benefit of the zinc-ion battery is its longevity. These battery systems are rated to have a lifespan of about 15-20 years which surpasses that of the lithium ion and lead acid batteries. This leads them to being replaced less often and allows them to be used in systems without need for replacement over long periods of time, which is ideal for the consumer.

Given this, the zinc-ion battery still has its drawbacks like every other battery system. First, it is not as energy dense as a lithium-ion battery and does not have the same discharge capability, as the zinc-ion battery simply does not have the capability to compete with other batteries in this sense. The zinc-ion battery is also much heavier than the lithium ion and lead acid style batteries, which is not an issue if the battery doesn't move.

The zinc-ion battery is also currently more expensive than its competitors due to its relatively new development in the power world, which will take quite some time to level down to a more reasonable price. As with all new technology, we can expect this price tag to decrease greatly over the next 10 years. When the prices of manufacturing these new zinc-ion batteries inevitably go down, we have seen this type of battery become much cheaper and widely used in systems due to its cheaper bill of materials.

4.6.6 Comparison and Selection

For this project, we have been using the Might Max twelve-volt battery. This is a lead acid battery that will produce 2.1 amps for 7.2 Ah. One main factor in choosing this battery is cost. For the applications we are building, a Lithium-ion battery would be better suited. However, the lithium battery comes with a higher cost and will give us the same output as the Mighty max.

The redox flow battery provides with many options that would be optimal with our design. When compared to the lead acid battery, it compels in comparison. With a better output value, discharge rating, and life span. This type of battery would be the preferred choice. However, two factors caused us to choose the lead acid battery. One was the cost of the battery. A redox flow battery would cost close to 1800 dollars for the smallest one currently on the market. This value alone makes this type of battery out of your reach. Another factor is the size of the battery. Because we are designing a smaller scaled version of the system, the redox flow would be an oversized battery for the design. If this design was being built to scale, and cost was not an issue, then the redox flow batter would be the better choice.

Zinc ion batteries, with their new technology, are outperforming lead acid batteries. However, they come with a much higher cost as well. When comparing the two, the life span of a zinc ion battery is a good draw to a customer. However, because it is a newer developed battery. The cost of purchasing it, kept us from selecting this battery.

Cost was a key factor in the selection of the Might Max battery. Also, lead acid batteries have been around for many years. They have been tested over and over, showing a good example of reliability. They can be mass produced at a constant rate. This provides us with the accessibility we could need if we need to purchase another one during the length of the project. This battery has proven to be dependable and can provide us with the desired output for the hydro generators. All in all, the lead acid battery will a good battery for the purposes of the project.

In order to help with the environmental concerns for lead acid batteries, this battery is sealed with ML7-12 absorbent glass mat technology, which helps to make it usable in any environment without leaking. One note of interest is that we have be purchasing two batteries. One will be used for testing and adjustments. The other will be purchased closer to the demonstration date. Purpose for this is because of the lifespan of a lead acid battery.

	Lithium-ion	Nickel Metal Hydride	Lead Acid (Selected)	Redox Flow	Zinc-ion
Capacity	3.3 Ah	11 Ah	7.7 Ah	120 MW h	7 Ah
Life Cycles	1000	1000	500	25000	15000
Battery Size	12 volt	12 volt	12 volt	150 volt	12 volt
Discharge	.65 Amps	.55 Amps	.66 Amps	.67 Amps	.65 Amp
Power type	Lithium graphite	Nickel Hydride	Sealed lead acid	Nafion cationic	Zinc manganese
Features	Recharge	Recharge	Recharge	Recharge	Recharge

4.7 Battery charge regulator

To accompany our battery system, we have needed a battery charge controller. A battery charge controller is a device that allows us to limit the amount of current being added or drawn from our battery system. This allows us to ensure a steady charge and discharge to and from our battery, which will ensure a high level of safety in our system. This will also be extremely important for our microcontroller, which paired with a voltage regulator will be receiving power from our battery system.

We have be using a solar charge controller, as they are designed to interface between the solar panel and battery system directly to ensure the most efficient charging. It is also

important to find a battery charge controller which is compatible with our lead acid battery, as some charge controllers are only suitable for nickel hydride, lithium, lithium ion, and other types of batteries. The two main implementations of the battery charge controller come in the pulse width modulation (PWM) charge controller and the maximum power point tracking (MPPT) charge controller.

The PWM solar charge controllers operate connecting directly from the solar array to the battery bank. In this case, it is our job to ensure the voltage of the solar panel matches the voltage of the battery system that it is charging due to losses created by having too much voltage attempting to charge the battery. The MPPT charge controller is typically seen as the better of the two, having much fewer losses for our system regardless of whether the voltages from our solar panels match that of our battery. This is because the MPPT solar charge controllers will down-convert the PV voltage to the battery voltage, allowing us to use any number or array of solar panels without having to worry about losses due to an abundance of voltage, such as 48V solar panels running into a 12V battery.

For the purposes of our experiment, a PWM battery charge controller will be all that we need. This is because we have already been using a 12V solar panel for our design, which means we have no need for down-converting power to a battery system while using an array of solar panels. Although the MPPT has the advantage of having no losses alongside even when compared to a PWM charge controller which has a solar panel and battery system operating at 12V, MPPT charge controllers are much more expensive.

Because our project focuses primarily on the implementation and function of the system, we have been using the Binen KLD1210, which is a PWM charge controller. This charge controller holds all the relevant specifications needed for our project while also having an LCD display screen which we can use to track data in our system. This charge controller is also very cost efficient which is always favorable. The relevant data specifications for the device can be seen below in the left most column.

MODEL	KLD1210	KLD1220	KLD1230	KLD4820	KLD4830
Batt voltage	12V/24V auto			48V	
Charge current	10A	20A	30A	20A	30A
Discharge current	10A	20A	30A	20A	30A
Max Solar input	<50V			<80V	
Equalization	B01 sealed	B02 Gel		B03 flood	
	14.4V	14.2V		14.6V	
Float charge	13.7V(default,adjustable)				
Discharge stop	10.7V(default,adjustable)				
Discharge reconnect	12.6V(default,adjustable)				
USB output	5V/3A				
Self-consume	<10mA				
Operating temperature	-35~+60 °C				
Size/Weight	150*78*35mm /150g				

Table 8: Battery charge controller specifications

4.8 Power Inverters

For this project, all of the power flowing through the system is in the form of DC voltage. This is because the solar panel generates DC electricity as its output, which then flows through the system we have designed and is fully compatible to power our devices given some voltage regulation and limitation. However, for the purposes of our system we would like to ensure that our outputs are taken out in AC power. To do this, we must put a power inverter into our system to convert the DC power to AC power for our loads. For this, we have been using a 12V DC - 120V AC power inverter known as the WZRELB power inverter. This is because we have need to convert our DC power to appliance usable AC power in the full implementation of our project, as we have been designing this power system for a home.

4.9 Sensors

Sensors are an integral part of any system, and ours is no exception. For our two-cycle power system, we have required the use of temperature, flow rate, voltage, current, and power sensors. The data provided by these sensors will serve various purposes, such as giving us data that we can then represent post processing, giving us flexibility to push our limits with the design, and most importantly keeping our system safe in the long term.

Having the ability to check the temperature of operation of our solar panels and other such devices will allow us to ensure that we do not have losses due to excessive heat, as our system is one that is going to be sitting outside for long periods of time. The flow rate sensors will allow us to provide data back to our microcontroller on the amount of water being pumped by the system to ensure the water pump is operating at an optimal capacity to maximize the output of the flow. This will also allow us to present this information to

the end user after storing and measuring it, which will provide some insight on the system and its performance.

We have also been integrating a light sensor into our project; due to the nature of the solar system we are also implementing. This light sensor will be able to provide more information on daylight which we have use in conjunction with our solar panels to measure efficiency and average weather conditions. For our last type of sensor, we can use a voltage, current, and power sensor all in one to give us a single sensor with three capabilities. This is useful for minimizing the amount of chips and sensors we need to purchase for our design, will help save space, and will also make reading measurements from our voltage, current, and power sensor much easier, as all the information is consolidated into one place.

4.9.1 Temperature Sensor

To verify that the system works while under operating temperatures for extended periods of time, a temperature sensor will be used to monitor the system while it is operating. The temperature sensor we use must be compatible with our microcontroller and must also be waterproof for some extra precaution as our system will have a water enclosure for our hydro system. Because of this, we have been using the DS18B20 temperature sensor using the microcontroller's power.

This temperature sensor comes with an easy to implement design, as the DS18B20 is able to communicate entirely through one wire for data and a ground wire. This device can also pull power directly from the data line. This makes the temperature sensor easy and reliable to implement into our system. This temperature sensor is also able to send an alarm with user-programmable high and low bound trigger points. This allows us to know when the system is getting too hot for our liking, which then allows us to know what is going on with our system. With a measuring range from -55C to +125C, there will also be no out of range temperatures for our temperature sensor. The specifications sheet for operating conditions can be seen in the figure below.

DC Electrical Characteristics

(-55°C to +125°C; $V_{DD} = 3.0V$ to $5.5V$)

PARAMETER	SYMBOL	CONDITIONS	MIN	TYP	MAX	UNITS
Supply Voltage	V_{DD}	Local power (Note 1)	+3.0		+5.5	V
Pullup Supply Voltage	V_{PU}	Parasite power	+3.0		+5.5	V
		Local power	+3.0		V_{DD}	
Thermometer Error	t_{ERR}	-10°C to +85°C			±0.5	°C
		-30°C to +100°C			±1	
		-55°C to +125°C			±2	
Input Logic-Low	V_{IL}	(Notes 1, 4, 5)	-0.3		+0.8	V
Input Logic-High	V_{IH}	Local power	+2.2		The lower of 5.5 or $V_{DD} + 0.3$	V
		Parasite power	+3.0			
Sink Current	I_L	$V_{I/O} = 0.4V$	4.0			mA
Standby Current	I_{DDS}	(Notes 7, 8)		750	1000	nA
Active Current	I_{DD}	$V_{DD} = 5V$ (Note 9)		1	1.5	mA
DQ Input Current	I_{DQ}	(Note 10)		5		µA
Drift		(Note 11)		±0.2		°C

Table 9: Temperature sensor specifications

4.9.2 Flow Rate Sensor

For our flow rate sensor, we have been using a Boleen water flow sensor. This sensor is capable of measuring up to 30L per minute, and can handle a flow of up to 2 MPa, making this more than bulky enough for our system. Our system will only be able to provide up to 240 GPH at our maximum power input, which translates to just under 16L per minute, which is something our flow rate sensor can easily handle.

During senior design 2, we ended up getting the flow rate sensor too late to implement, though this was already a small part of our project to begin with. We were unable to get data on the flow rate of the system because of this, but had plenty of other supplemental system data in other places.

4.9.3 Voltage, Current, and Power Sensor

For our final sensor, we have been using the Adafruit INA260. The INA260 is a popular type of sensor which integrates voltage, current, and power sensor capabilities into one single package. This kind of sensor will be very useful to us when integrated onto the microcontroller and will let us measure all power flowing through our system when fully implemented. This will be very useful for getting useful information packaged nicely that can be presented to the end user on a website.

		MIN	MAX	UNIT
Analog input current	Continuous Conduction		±15	A
Analog inputs: IN+, IN-	Common-mode ($V_{IN+} + V_{IN-}$) / 2	-0.3	40	V
Voltage	Supply, VS		6	V
	VBUS pin	-0.3	40	
	SDA, SCL, ALERT	-0.3	6	
	Address Pins, A0, A1	-0.3	VS + 0.3	
	Open-drain digital output current, I _{OUT}		10	mA
Temperature	Junction, T _J		150	°C
	Storage, T _{stg}	-65	150	

Table 10: Voltage, current, and power sensor specifications

4.9.4 Light sensor

For this project, we have also need a photoresistor light sensor as mentioned previously. This sensor will come in handy when combined with data from our solar panel, as this will help guide the efficiency of our system and will allow us to determine whether it is simply weather conditions getting in the way of the solar panels maximum operating output. This information can be useful as when there is an overcast day, it may still be daytime, but the sunlight radiance is not at its maximum potential.

Photoresistors or light dependent resistors (LDR) are devices which increase in resistance the less light is hitting them. This type of device is already used in solar applications such as solar streetlamps, which means implementing it into our system should be straightforward. The photoresistor we have been using is the PB: LTR-553ALS-01, as it is readily available and has similar characteristics to the OPT3002, which was what we originally intended on using. Below we can see a rough model of the output characteristics of this photoresistor, which shows that during average daylight wavelengths from 400-800

nm, we can see an output response given to us which will allow us to determine light intensity as well.

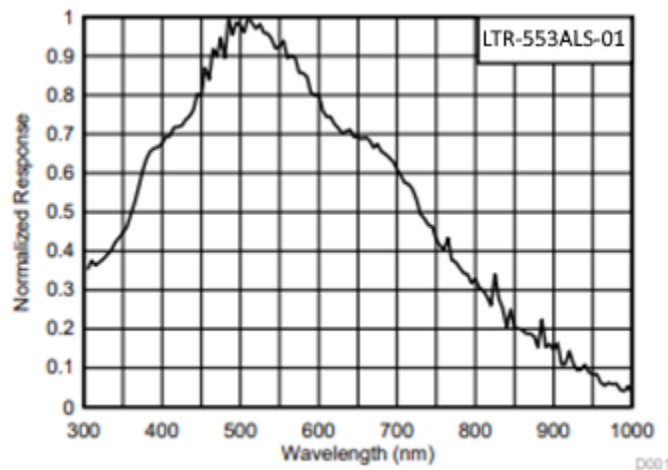

Figure 7: Light sensor normalized response

Instead of using a light sensor, we decided to simply look at the panel output wattage and see if it was generating enough power using the other sensors we had implemented in our system instead. This meant that we did not end up implementing the light sensor, though we had purchased it and were ready to do so regardless.

4.10 Microcontrollers

For our project, we still require a device that we can consider the brains of our design. This will be a microcontroller, which can perform tasks that can assist us to ensuring our design functions properly. When looking into microcontroller technology, there are many different kinds of microcontrollers to suit all different types of projects. This is because nearly every system which has electricity also requires some form of computation or analysis to be performed in real time.

When looking at the different kinds of microcontroller applications, they have a wide range from being used in mobile phones, automobiles, computer systems, security alarms, and appliances. As such, microcontrollers can come in all forms and fashions, and can vary greatly in the array of tasks that they are able to perform. The architecture of the microcontroller that we choose for our design will be imperative to the design of our system, and we have been comparing three main kinds of host microcontrollers, alongside two different peripheral microcontrollers.

4.10.1 Host Microcontroller

When choosing the main microcontroller capable of fitting all of the design constraints and deliverables, multiple microcontrollers came in questions, among the top choices to be considered where the MSP430FR6989, the ATmega328 and the RP2040. The MSP430 being the microcontroller where all of the group integers have the most expertise with, the ATmega328 being a widely used mainstream microcontroller unit used in the popular

“Arduino” boards. Among the top factors influencing the decision, the following table illustrates the key differences among the mentioned microcontrollers:

Spec.	MSP430FR6989	ATMega328	RP2040 (Selected)
CPU Clock	16 MHz	20 MHz	33MHz Dual Core
SRAM	8 KB	2KB	264KB
FRAM	128 KB	-	-
Flash	-	32 KB	Up to 16 MB
Architecture	16-Bit RISC	8-Bit AVR	32-Bit Arm Cortex-M0
Price	\$12.09	\$2.18	\$1.00

Table 11:Microcontroller comparison

As illustrated on the above table the RP2040 provides superior performance and memory capacity than the MSP430 and the ATMega328. Furthermore, influencing the team's decision to choose the current processor, RP2040, is the ability to design and implement algorithms to manage our systems design using Object Oriented programming, specifically, Micropython. Micropython is an extension of the high-level language, Python, dedicated to microcontrollers. Micropython provides some Python intrinsic functions such as “math”, “socket”, and some other low level basic, low-level libraries. Micropython, of course, also implements low level communication interfacing libraries for the microcontroller units such as UART, I2C and SPI.

Some of the difficulties of pursuing our algorithms design and implementation with Micropython is the lack of coverage for some situation specific functions such as Slave Functionality for SPI and I2C. Given the engineering industry's bias and availability for a wide range of microcontroller units that are meant to be programmed in C or some variation of C, there is currently a lack of resources and support for the development of embedded applications using Micropython. However, the versatility of the language as well as good libraries for networking applications is enough of a tradeoff to continue the development of our application using this Object-Oriented language.

For our main system architecture, we have been utilizing one main microcontroller unit consisting of the above mentioned RP2040 as well as one MCU capable of providing wireless connectivity to an externally hosted application to manage all the telemetry metrics obtained at runtime as well as error reporting and overall system status.

4.10.2 Peripheral Microcontrollers

For the processing unit capable of wireless connectivity, there were a couple of widely used options available capable of fulfilling this requirement. The main factors taken into consideration to select our Wi-Fi module are mainly the CPU clock speed, RAM in order to buffer a decent amount of data before sending it via a POST request to the base station as well as TCP/UDP requests processing power and speed.

There are, indeed, very limited choices when it comes to selecting embedded type Wireless Communication modules, to be used as a Wi-Fi adapter for our host MCU, most of the Wi-Fi adapters in the market have an interface implementation dedicated to high level operating systems requiring drivers to be stacked in order to properly communicate with the main processing unit. In other cases, these wireless communication modules do not have developmental / evaluation boards readily available for debugging and circuit / software design and are sold as standalone chips for custom PCB design.

After thorough research, the decision was made to skew the design efforts towards basing our design on the leading wireless MCU's and IoT manufacturer, EspressIF. EspressIF, represented the most convenient, and affordable way to move forward with our design efforts.

The most relevant and advanced microcontroller units manufactured by EspressIF are shown in the table below as well as the key specifications that will benefit our system design the most.

Spec.	ESP8266	ESP32 (Selected)
SRAM	64 KB	520 KB
CPU Clock	80 MHz	240 MHz
Size	4.61 x 2.44 x 1.57 inches	4.5 x 3.46 x 0.75 inches
Price	\$5.29	\$10.99

Table 12:SRAM and CPU clock comparison

Surprisingly, despite the superior performance of the ESP32 in terms of clock speed and memory, for ambiguous and not obvious reasons the request time for TCP/UDP type requests is at least 4 times slower for the ESP32 when compared to the ESP8266. This metric was recorded first handedly and through 3rd party experiences documented through blogs and journals. Part of the reason speculated for this problem is the inflexibility of the current libraries and IDE's setting to the ESP32, given that the ESP8266 is the ESP32 predecessor and almost all practice in the IoT field was adapted to the ESP8266.

Having said that and having gathered first handed metrics in regard to each device's performance, our team selected the ESP32-WROOM-32D, a variant of the ESP32 base model, often referred to as the ESP module, Wi-Fi module and Wireless Communication module in this document. As far as the development tools utilized to create the firmware for the ESP device, there are a few options available:

- AT Firmware

The AT firmware, inspired from the Hayes command set, was first utilized on the 1980 baud modem, and was used to control the dial up connection. The imminent issue with this firmware is its low-level implementation and speed.

- NodeMCU Firmware

This firmware allows the user to program and develop applications using C/C++ and almost all of the Arduino type libraries are portable to the ESP this way.

- Micropython

As explained early in this section, Micropython is an extension of Python that carries the majority of its object-oriented programming modalities. Almost all of the libraries on the Micropython firmware are shared among the few devices capable of running Micropython with the exception of a few networking libraries such as sockets and network which are intrinsic to the ESP devices capable of wireless connectivity.

Aside from speed limitations on the ESP32, there are other limiting factors that need to be taken into consideration as well. As the RP2040 will be used as the host MCU and every other MCU or chip will be used as a peripheral, MCU to MCU communication needs to occur. After some ample research in regard to the protocols most often used when communicating from MCU to MCU, UART was the most commonly used, easier to implement and it also adhered to the feasibility and limitations of using our development language of choice, Micropython.

Among other communication protocols used to communicate among MCU's, were I2C and SPI. SPI and I2C can achieve much higher data transfer speeds than UART. However, in our case these protocols were not feasible to implement given our development tools. Because of the lack of support for the Micropython language, some communication protocols are not implemented at a high level, i.e.: Library level. Such protocols allow the usage of the host MCU as a Slave on an I2C bus or on a SPI scheme.

This was of special interest when trying to use the ESP8266 / ESP32 as a peripheral to the Host MCU (RP2040), given that both the ESP8266 and the ESP32 are capable of being programmed using Micropython. A way around this is by flashing the Node MCU firmware to the ESP, which is essentially C/C++. In the end, the approach followed to implement the inter-board communication was UART for at least Rev A of the firmware solution.

4.11 Wi-Fi Modules

For our project to function properly and send information the way we want it to, we require the use of a wi-fi module. This is because the peripheral microcontroller will be used to

process the information presented to us through the wi-fi module, as we do not have a wi-fi module built into our host microcontroller. This means that we have need to implement a wi-fi module as described above in the peripheral microcontroller section.

To understand what kind of Wi-Fi module we need, we first need to look at what Wi-Fi standard we have be using for our project. In looking into this, we can see that there are only a few major Wi-Fi standards we need to consider, as these are the most widely available. The world of Wi-Fi runs entirely on the IEEE 802.11 standard. This standard has many applications and is used everywhere in the world of Wi-Fi communication and transmission.

The 802.11 standard is further broken down into categories, each with slight differences primarily due to their creation and release. The five primary applications of the 802.11 standard are A, B, G, N, and AC. Each of these is capable of receiving or sending different frequencies of signals, or will vary in range as it is easier to transmit a lower frequency signal over a longer range. For our project, we have only been focusing on the B, G, and N applications. These applications of the 802.11 standard will be important, as they will determine the frequency range and data rate of our wi-fi module.

The 802.11b standard can handle up to 11Mbps at 2.4GHz, the 802.11g will handle up to 54Mbps at 2.4GHz, and the 802.11n is the most robust of these standards and can handle both 2.4 and 5GHz ratings, as well as having a data transfer speed of 600Mbps. These three standards will be more than enough for our project, and most modern wi-fi modules that we have be looking at will have these compatible by default. It is also worth mentioning the higher power standards, such as 802.11ac or 802.11ax, which are both much newer and more powerful technology. The main difference here is transfer speed and price, where the two ac/ax applications can handle upwards of 1.3Gbps and 12+Gbps respectively.

When choosing a wi-fi module that suits our needs, we only need a module which is flexible and can work with our system. The most popular forms of wi-fi modules come with the TCP/IP protocol stack integrated into them already, which is necessary for wireless transmission of data. This will allow us to gather all the data in our system using the microcontroller and send it wirelessly through the wi-fi module to our website of choice. When considering our options above, it is likely we only need a wi-fi module capable of transmitting on the 802.11n standard, as it will be more than robust enough for this project.

Because wireless data transmission is a large part of the integration of our complete project, we have been talking more about how this is integrated into our system in the design section. We need a module which is compatible with the forms of transmission that our chip is capable of. This left us with choosing the EspressIF wi-fi module, which is fully compatible with our system and is also 32-bit, which means it will be very robust. This wi-fi module is compatible with the 802.11b/g/n standards, which means it is a suitable fit for our system.

4.11.1 Technology comparison: Bluetooth vs Wi-Fi

While deciding how we were going to handle the transmission and sending of data to a webpage, our group briefly considered the possibility of using a Bluetooth module instead of having a wi-fi module do all the work for us. However, the typical Bluetooth module

tended to be the same price as the relevant wi-fi module, and does not compare whatsoever when considering the range in which we are able to send data. Because we would like to have this system be able to send data to any webpage of any form, it was simply easier and more efficient to choose a wi-fi module over a Bluetooth one.

However, to not lock ourself out potentially needing Bluetooth in the future, we decided to also choose a wi-fi module that also had a Bluetooth transfer protocol ingrained into it. For this case, our EspressIF wi-fi module also has Bluetooth 4.2 integrated into it, which would allow us the option to use this instead of wi-fi if we should so choose. This Bluetooth feature would consume more power if used, but otherwise is simply an additional option on the wi-fi module we have chosen.

4.12 LCD display

To display the information that we obtain throughout our project, we have be using a liquid crystal display, LCD panel. The LCD works by using a backlight or reflector to produce images and display information. This display panel will be able to show us information on our sensors, power outputs and inputs, average load data, and much more. Eventually, we would like to integrate the wireless communication to our system which will mean we can monitor our data not just on the LCD, but on a mobile device or computer. However, we still need a place to monitor data in the event that the wireless module is incapable of transmitting data, or in the event that a critical system failure happens, and we want to access the data directly on the system, ignoring the transmission of data.

LCD displays are an integral part of any form of power system design, as one of the key components to a power system is the ability to monitor said system and ensure its safety and efficiency. We have been needing a reasonably sized LCD to allow us to fit all of our data onto it but displays can come in many various implementations. They key distinctions between LCD displays come in refresh rate, color accuracy, viewing angles, brightness, size, and price. The three main implementations of the LCD we have be looking at are the TN, VA, and IPS panels.

4.12.1 TN LCD panel

The TN display panel is the oldest implementation of the LCD. They also remain the cheapest, and fastest form of the LCD panel. This is because they require little voltage and operate on a single transistor per pixel. We can adjust the voltage to any level to display varying levels of gray. This type of panel is one most commonly used for applications with low voltage, which require fast responsiveness and good data flow.

The main issue with the TN LCD panel is that it is a very old design. These types of panels see use in high end gaming monitors as well, as they are capable of getting higher refresh rates than their IPS competition, but when looking at smaller TN display panels for this project, we have trouble finding ones that we can use practically. Though these types of panels would be cheaper to purchase, IPS technology has come down in price significantly in recent years.

4.12.2 VA LCD panel

After the TN display panel comes the VA display panel or the vertically aligned display panel. This type of display is better than the previous TN panel in most situations and are typically seen as the middle ground between the TN and the IPS display panel, having some advantages of both while not being the most expensive. The VA monitor has the potential for the highest refresh rates, providing potentially the smoothest images. For general work these types of monitors can provide good contrast ratios and brightness, and also give us some decent viewing angles. However, as an in-between option the VA panel has little going for it. With its awkward niche being a slightly worse IPS display panel that can attain higher refresh rate, it is not ideal for our project.

4.12.3 IPS LCD panel

Finally, we have the IPS panel. This type of panel implements switching that requires two transistors per pixel instead of the normal one transistor for the VA and TN panels. The IPS panel is the most modern of the three panels, and allows for the highest level of contrast, detail, lifespan, viewing angles, and visibility. This is because the implementation of having two transistors per pixel significantly increases the potential brightness and detail available to be displayed. These forms of panels also have the longest lifespan of any other type of display panel.

However, no product is without its drawbacks. In this case, performance of these panels is better in every case except three key ones. First is response time, in which TN panels have the fastest response time of typically at most 1 millisecond. They are also very expensive when compared to the TN and VA style of display panel and are very inefficient when it comes to their power consumption.

4.12.4 LCD selection

After carefully considering the different forms of LCDs, we have been choosing to use the pixxi LCD-13P2. This type of IPS LCD display is comparably priced when it comes to its close competitors and is the highest quality display available to us. When compared to other IPS displays, it is relatively cheap within its own family and comes with its own processor. This processor is going to be able to give us the ability to design the UI with different images and graphs, allowing us extra utility and making our display functionality a little bit more robust despite its small size. Alongside this, it was more difficult to find the older types of displays than we anticipated, making this IPS display the optimal choice for us.

Below, we can see a quick comparison of the three types of technology available to us, assuming the same style and size of display for each type for a more just comparison. We can see that the main differentiating factor is really the brightness and cost when comparing similar display technologies. Highlighted in green is the display which we have chosen, in this case the IPS display category.

LCD type	TN Display	VA Display	IPS Display (Selected)
Viewing angles	160 degrees	178 degrees	178 degrees
Brightness	346 nits	364 nits	385 nits
Display size	1.3"	1.3"	1.3"
Dimensions	240x240	240x240	240x240
Price	\$26	\$32	\$35

Table 13:LCD Displays Comparison

With all the research we did for the LCD panel display, it ended up being too small for us to display the data we wanted to display, so we ended up just showing all the system data on the website instead. Though we were only planning on showing the most critical of system information on the LCD panel to begin with, such as critical failures and other things, we decided to spend our time improving our website rather than using the time to implement the tiny LCD screen into our project, which we were successful in doing in the end.

5.0 Project constraints

Constraints in all projects are either recognized from the beginning or are noticed during the process. It is a natural part of the process. Once a constraint is found, research is needed to be done to find ways to solve the constraint. They can be either something small or a large issue. Solving the constraint quickly, will keep the project on schedule and help in keeping the project cost down. This also helps in ensuring a smooth transition between design and implementation.

In our project, we have been looking at constraints not just on the system as a whole, but even down to its components. This is because one part of a system will have a longer list of constraints placed on it such as battery technology standards and constraints and can affect how we must proceed with designing the rest of our system. Design constraints can be limited to physical capabilities, part incompatibility, software capabilities, part shortages, and much more.

5.0.1 Physical Constraints

Considering this project is still early in the development process, constraints have been limited so far. However, an early onset problem arose when considering how to make the water pump system produce more power than it consumes. Possible solutions include the utilization of natural flowing water sources to help in the production of energy, however that would limit the locations in which the system could be implemented.

Another constraint arises when considering the efficiency of power transfer between the power generation sources, the system monitoring and distributing the power, and the load sources the power is being distributed to. It is easy due to wiring errors, part incompatibility, etc. for a power system to experience loss and would require investment on the development of this part of the system to mitigate loss as much as possible.

5.0.2 Software & Circuit Design Constraints

One of the core deliverables for our system is the ability to deliver telemetry data with respect to the system status, usage and load demand to the user wirelessly not connected to the same local area network (LAN). The telemetry data transmitted to the user consists of the key components power status / metrics as well as commands inputted by the user directed to the system.

Given that our design bases all of its decision making and all of the status data to be streamed into the remote server database and into the device itself for remote commands, the use of design practices that are exclusive of single point of failure faults to the system in the event of connectivity outages, software bugs and electrical failures related to the monitoring system is imperative, for which, a local control system with a simple interface for controlling the core functions of the system as well as providing the main system status will be implemented. This extra feature is a constraint to our system, because in the case of an outage the system will not be able to stream the massive amount of data generated by the system to the remote server's database and will only be able to provide the most native functionality to keep the system running.

5.0.3 Marketing constraints

When designing a system, we begin to wonder how the system would fare on the market. Some design processes are not made to make money but are used to save cost for a company. In our design, we decided to scale the size of the system down to a manageable system. Because cost was one of our biggest issues, making the system small enough to afford quickly became a high priority. In order to get a full scaled system would give us a better understanding of how the design will affect a power system. However, that would come with a higher cost then we are able to pay. Looking at just the solar component alone, it would cost close to 10,000 dollars to build this design. Adding in all the other parts of the design. This created a price factor that was just well beyond what we were able to come up with.

Another marketing constraint comes with the amount of savings on energy cost. A full-scale system would generate enough electricity to lower the everyday energy bill. Also, many power companies offer credits for homeowners that can send extra generated energy into the power grid. This benefits both parties, cause power companies have a set price to produce energy. Many times, this is much higher than what they would credit a customer. With a smaller scaled system, we have still been able to obtain the power required for a load and the amount of power generated. This will show us the efficiency rating as well. Knowing this information, would allow us to see the potential in power savings. There will still be other factors that will limit the validation of energy cost calculations, but for the purpose of this design, we have focus on the working parameters, then the full scaled results.

After getting a fully flushed out design, we would be able to use theoretical software that could calculate the savings and power output for a full scaled system. However, the software was not able to scale to our design. Even with different system installed. The focus of the design is implemented, and we have be able to study the amount of savings that would be expected from our system.

5.1 Related project standards

As with all engineering related things, there are standards which place constraints on our system and how we are going to need to design and build it. These constraints and standards will affect all parts of our project design, not just the hardware or software components alone. Standards are an integral part of any form of engineering, as they can serve as a guideline towards building a successful, and more importantly a safe system.

In our project, a few standards can be established for our major components. These component standards will apply to things such as our solar panels, our micro-hydroelectric system, our battery system, and our loads. With these components in mind, we have been going over standards pertaining to their design not just in Florida but in all parts of the United States. This means we have also been attempting to comply with any federal standards placed on the design of our system, which will be important specifically for our solar and battery systems.

There will also be standards that relate to our project in a broader sense, such as coding standards, PCB design standards, and installation standards regarding our systems installation as an entire product. The highest level of standard is that of the National Electric

code, whose standards and codes are accepted in all 50 states in the US. This means that any form of electrical system within the US will need to comply with these codes on top of complying with any forms of state codes as well. There are some exemptions for smaller systems which will be brought up again when talking about standards in our solar system.

On top of this, we also have the Institute of Electrical and Electronics Engineers, or IEEE. IEEE is a famous institute which really requires no explanation, but their impact on standards within electrical and electronics engineering cannot be understated. In the design of our project, we have been referring to IEEE standards pertaining to our battery system, which helps guide us in a better direction in terms of successfully designing a lead-acid battery system for this application. Though it is important to note that a subscription is required to access many of the IEEE standards listing, many of these standards can be found in small chunks throughout various academic resources, which will allow us to have a method of looking into these standards.

We also have the standards from the International Electrotechnical Commission, or IEC, whose standards are accepted and highlighted by multiple government related standard related documents. The IEC is an international standards organization who has a membership total of 89 countries, including the United States. This means that at every level, the standards and constraints set forth by the IEC must be adhered to. This makes the standards of the IEC important to conform to in all situations.

5.1.1 Standards in solar systems

For the solar component of our system, we have been taking a look at many different relevant sets of standards for solar design. Two of these standards that we have been looking at will be given to us by the state of Florida in the document “Procedures for Photovoltaic System Design Review and Approval”. This document outlines various standards developed by the Florida Solar Energy Center. We have also been referencing standards from the IEC, who have a substantial list of solar related standards that we can use to help us design our system.

The FSEC designs standards in accordance with Florida law and is charged with developing standards based on the best currently available information. They are also tasked with establishing the criteria for testing performance of the solar systems. These rules are even published in references in the Florida Administrative Code. This gives credence to the standards developed by the FSEC. The FSEC is also in charge of certifying all PV systems and modules that are sold or manufactured in Florida.

To begin with, the FSEC outlines two general forms of solar PV systems in their standards publication. These two PV systems are grid-connected systems, and stand-alone systems. We have first consider the grid tied system case, which is the case that this project's implementation is being modeled after. A grid-connected solar system is split further into two categories, being the grid-connected PV system with and without a battery storage unit. Though separated, almost all of the standards for the system including the battery can be applied to the system without the battery, so we have only been considering the case with the battery system as it is the type we are looking to successfully implement.

When attempting to design and install a solar PV system with a battery included, we run into a few key issues when it comes to the power grid needing to be turned off. This issue

can lead to dangerous conditions for line operators if not properly considered, since in times of excess electricity the battery system will be sending electricity back through the power grid, typically for a credit to the consumer. This means that if a line operator touches the line assuming that the grid is shut down, they can be injured or even die.

To solve this, the FSEC states that there must be control circuitry in the inverter which transfers energy to the AC loads and electric utility that can force the line between the grid-connected PV system and the electric utility to open, which would stop the electricity from flowing back into the de-energized grid. This also means that the battery system and PV panels will still be able to successfully supply the load, as there is nothing stopping them from working.

Next, we look at the installation constraints for low voltage electrical PV systems, which applies to the implementation of our project in this case. We can find this constraint from the IEC as well. Because our system would be designed with installation into a home to supply power to loads in mind, these types of installation constraints are important to keep in mind as they can affect how the system enclosure is built. When looking at these, we can refer to IEC standard IEC 60364-1. This outlines the rules for the design, installation, and verification of electrical installations for low voltage applications.

On the safety side of solar panel constraints, we run into issues concerning system safety and the overall balance of the system itself. The IEC recommends that all solar PV systems be built with fuses that can be safely used if a system overload happens, or if a critical issue happens within the system. There are testing standards that are recommended for use when attempting to verify whether or not a system meets standards, which are outlined in the IEC 61730-2, which can give us the test sequence and criteria that must be met to verify the safety of our PV systems.

Though we have been considering the use case above when designing and developing the constraints, our system itself will be a stand-alone system when fully realized. This is because of the nature of our project, which would require us to have access to a home to install it into successfully. However, there is a condition in a memo published by the FSEC particularly mentioning small scale PV systems and their certification. This memo states that there are particular criteria which can be met to allow exclusion of a solar system to comply with the national electrical code. This includes systems which meet all three of the criteria mentioned in the memorandum, which are:

- Systems operating a maximum voltage of 30V, operating currents of 10A, and maximum circuit power of 240W.
- Systems with a limited, dedicated load, such as a lamp or a water pump.
- Systems without a direct connection to a serving electric utility

Due to the nature of our small scale two-cycle power system for this senior design project, we have not been going through the process of certifying the system through FSEC as it is not required. This allows us to work freely without worry. It is also worth noting that the solar cells that will be used in our system are also exempt from certification, as they are part of a system which in of itself does not need to be certified to begin with. This will save us from having to officially comply with the codes and regulations outlined in these documents, but we have been attempting to comply with them anyway, as it is a necessary step in making our system fully realizable and realistic.

5.1.2 Standards in battery systems

For the battery system we have been using in our design of our system, we have been designing these based around various battery standards within the US and more specifically within Florida. Because the battery system we have been using involves a lead acid battery, we need only to look at battery standards surrounding the lead acid battery. Luckily, as lead acid batteries are over 150 years old, they are essentially battery systems which have been fully realized at this point in their life cycle. This gives us a plethora of guidelines and standards that will help guide the direction of our battery system.

When looking through lead acid battery standards, it is most important to first look at the application for which standards will need to be considered. For example, the standards surrounding the design of lead acid batteries in automotive systems is completely different from the design of lead acid batteries in typical power system design. This is because clearly the two implementations will be quite different, will require different outputs and compatibility, and will also require us to develop these systems under different operating condition considerations. This can be illustrated by comparing how a lead acid battery must operate in a moving vehicle as opposed to a stationary power system.

When looking at the design constraints around solar PV systems which include a lead acid battery directly, we can look towards the “IEEE 485-2010”, which are the recommended ways of sizing lead-acid batteries for stationary applications. These types of applications would include our two-cycle power system. This standard assists in outlining methods for determining proper sizing and output needed for the battery of our system. In addition to this battery standard, we also have the “IEEE 937-2000”, which more specifically outlines the recommended practices for not just installing, but further maintaining lead-acid batteries in PV systems, which is directly important to our type of system.

In this standard, we can see recommended regulations which can depend on storage, location, mounting, ventilation, assembly, and maintenance of lead-acid battery systems. It is worth noting that these types of standards and regulations should be applied to all lead-acid batteries, regardless of size or application so long as it contains a storage subsystem, all outlined within the standard given to us by IEEE.

Additionally, we have standard IEEE 1013-2019, which is a newly updated battery related standard relating to lead-acid batteries in stand-alone PV systems. This standard documents how one should go about sizing and choosing a properly lead-acid battery for the PV system. This standard details typical design constraints and recommended sizing methods for these types of batteries in only our case as well, since it is beyond the scope of this standard to comply with grid tied or hybrid grid systems. While the final implementation of our solar system is to have it in a home ideally, for the purposes of real design we have been attempting to adhere to standards such as this one.

5.1.3 Standards in Micro Hydropower

When it comes to micro hydroelectric systems, most of the standards come from the area surrounding the hydropower system. This is because there is water involved with hydro systems, and this water typically belongs to someone or requires a permit to be used or diverted. Whether the system is grid connected or a stand-alone system will affect the implementation of the hydropower system and will determine what constraints we must

follow. For our case, will be looking at hydropower systems that are tied to a grid so we can send electricity back to the power company in times of excess energy generation.

When looking into micro-hydroelectric standards, we find that our implementation of hydroelectric power is classified under more of a pico-hydroelectric system than anything. This is due to the scale of the implementation in our project, as well as realizing that the power generated from this portion of the system is likely to be under 10 W of power independently. This would classify our system as a pico-hydroelectric system.

As previously mentioned, simply having water nearby is not enough to establish use of the water for a micro or pico-hydroelectric system. In these cases, we can look towards an exemption in the case of small hydropower systems, much like was the case for our solar component of the system as previously mentioned. In most cases, this is as simple as contacting the county or state engineer to verify ones right to use water without interfering with other more significant issues.

All hydroelectric systems are subject to the approval of the Federal Energy Regulatory Commission, or the FERC as long as they are connected to the grid, no matter the size. For the purposes of our senior design project, we can find an exception for our type of system from the FERC themselves, where they state that small hydropower systems under 5 MW can be used without the need for approval, so long as they use their own conduit or a pre-existing dam.

Finally, there is a standard very relevant to the design of our system specifically in terms of using a PV system with a pump as an integral part of our system. This standard is given by the IEC, as standard IEC 62253:2011 which defines the requirements for the design, qualification, and performance measures of a PV pumping system when it is operating on its own. This most often applies to systems used in smart city development or rural electrification, but the standards help direct our system as well.

5.1.4 Standards in PCB Design

When looking towards the design for our printed circuit board, or PCB, it is inevitable that we turn to the Institute of Printed Circuits, or the IPC. The IPC has been in operation since 1957, and its goal is to standardize the assembly and production requirements of electronic equipment and assemblies. The IPC is an internationally recognized group, whose standards greatly affect the world of PCB design. When considering the design for something like a PCB, it is important to realize that without standardization, this type of production would suffer greatly from constantly having to adjust for every type of implementation due to the variable nature of what a PCB can be used for and what they can be needed for.

While it is no secret that there is no standard definition for success, the IPC standards will definitely guide us in the direction of building a reliable and stable PCB for our design. Using the IPC standards will ensure good quality and reliability, improved communication, and reduced costs. Having a design for our PCB that complies with these standards will also make it easier to get our PCB sent and printed in a reasonable amount of time, as getting a PCB can take a very long time in some cases. With time constraints, this would not be a good direction to have to take in this case.

When looking into what standards we should be following with our PCB design, a few IPC standards stand out immediately. These standards are the IPC-2581 and IPC-2221. The IPC-2581 standard focuses primarily on sending information between those who design the PCB and those who manufacture or assemble said PCB design. This allows for a stable and standardized information exchange that helps ensure that the results of the design will be in line with what was desired. This is an extremely important standard to follow as due to chip shortages in recent years, a miscommunication in the PCB process can result in a large wait time to fix.

IPC-2221 primarily focuses on the design of the PCB itself. It is a standard which goes over the process of designing PCBs, and focuses on topics such as design layout, materials, parts lists, mechanical, physical, and electrical properties and many more. Using this standard, we have been able to design our PCB with useable and easy to purchase parts to allow us to be able to get our PCB manufactured. In our current PCB climate, there is a chip shortage going on, which means we must design our system with whatever chip we have at our disposal or that can be easily designed around in accordance to the IPC standards. As we have not be manufacturing the PCB ourselves and only designing it, we have not need to look at any manufacturing standards when it comes to the PCB.

5.1.5 Standards in System Installation

When talking about any installed power system, it is important to know about wiring installation constraints and standards. These are the types of standards that will undergo the heaviest levels of testing for safety, and have many standards regarding safety, testing, design, and installation. Occupational Safety and Health Administration, OSHA, alongside the National Electrical Installation Standards will help guide us in the proper direction when considering what standards apply to our electrical system installation.

Taking directly from OSHA's website, we can see standards in wiring methods, components, and other equipment that gets used when installing electrical systems from standard 1910.305. In this standard, OSHA states that wiring must be permanent and cannot be placed with forms of duct tape and other such means of flimsy wiring. This also applies to any cable trays, armors, sheaths, enclosures, frames, fittings, and any other metal non-current carrying pieces in the system design. This is to ensure that the installation will be as permanent as possible.

This standard also goes over all forms of input and output standards, and also goes over various forms of allowed methods for installing various components of an electrical design installation. It is also important to note that there are specific methods detailing how to begin disconnecting the system from the grid and uninstalling. This is because no single electrical system will be permanent, and will eventually need to be removed, replaced, changed during maintenance, or upgraded far in the future.

We also have standards relating to the installation of PV systems, similar to one discussed in the solar standards section. This time, however, we refer to the PV systems installation when connected to the grid. The standard we have be looking at is IEEE standard 929, which simplifies the PV systems connection to the grid, and ultimately makes the systems connection much safer for linemen, the utility company, and the customer alike. This standard also has benefits in reducing cost installation and makes it easier for solar PV

systems to become more used today, so it is a standard we have been looking at for this project.

5.2 Other project standards

Not all applicable standards for our project depend entirely on physical components of the system. In our system design, we are implementing things such as code and sensors to monitor the system, which also contain their own sets of standards that we would like to abide by or try to implement in our design. Standards often streamline things and make it easier to set some baselines we want to hit for our project.

These standards will include things such as the handling of writing our code, the handling of the documentation for our project, how we go about monitoring the system and deeming something dangerous, and how we should handle the power information of our future consumer. Also included is information on the various Wi-Fi standards and how we have been putting them to use and deciding which ones to use in our project.

5.2.1 Standards in C/C++ Programming

When considering related standards in programming, most standards are more of best practices than they are verified standards set forth by an organization. This is because the process of coding is a subjective task but can still be done in ways that will provide a generally cleaner, fully, and more optimized approach. Though it is difficult for any single coding standard to be used in every case or for every type of environment, a practice with good coding standard is much better than no coding standard.

These standards are widely adopted by people who program regularly, and include things such as ensuring proper memory allocation, ensuring that the code is self-documenting, and to not attempt to completely rewrite data and algorithms if they can already be found in pre-existing libraries. We can look at the C++ core guidelines, C++ coding standards, and other such documentation which is the work of many individuals over many years as a standard that we can use to base the code we have been writing for our project on.

5.2.2 Standards in technical documentation

In all products and designs, there exists a large amount of technical documentation. Technical documentation refers to the documents that involve product-related information and other types of data. It has all the details and nuances about a technical product or service being provided. As we are producing an engineering project through the design and development of our two-cycle power system, it is important to keep in mind standards and rules that will help us correctly document the data required of us in this document. Technical documents are things such as patents, specification sheets, data sheets, testing methods, and so forth.

With all sets of standards, there is an organization that sets those standards and is typically viewed as an authority when it comes to their class of standards. In this case, we have been looking at the International Organization for Standardization, or ISO. The ISO has published various standards relating to the rules of preparing manuals, specification sheets, and other user guidelines for projects. These standards can be found in ICS 01.110, where

anything not listed in this standard is listed in more discipline specific standards documents.

5.2.3 Standards in System monitoring

As we have be interfacing data between our devices and sensors into a microcontroller, it is important to consider the systems monitoring system, as well as the systems cyber security aspects. This is because electrical information can be valuable to hackers, and if the system is designed poorly could even allow hackers access to the local power grid if handled poorly. This could also lead to consumer data being obtained or used illegally by someone who is able to hack into the weakened program and start rerouting data.

It is also important to have accurate system monitoring, as the performance and analysis of a system is key to its longevity. For this, we can look at a standard from the IEC, standard IEC 61724-1:2017. This standard outlines the equipment, methods, and required knowledge on terminology for performance monitoring and analysis of PV related systems. This standard helps us as it addresses installation of the system, as well as sensors, and accuracy for the monitoring equipment. This allows for good data acquisition and quality checks. It also helps serve as a good foundation for other standards which rely on the data that we collect from our power system as a whole.

5.2.4 Standards in Wi-Fi Communications

In this project, we have been making use of the EspressIF Wi-Fi module, ESP32 to wirelessly transmit and receive our data. In doing this, we have need to adhere to standards relating to Wi-Fi. The most common Wi-Fi standard today is the IEEE 802.11n. This standard handles the WLAN transmission level of data and is constantly being updated to include all new and relevant technologies and will handle 2.4, 5.0, 6.0, and even 60GHz transmission.

The strength and simplicity of the 802.11n Wi-Fi standard makes it easy to implement and use and is used by billions of devices worldwide, but this standard is also intertwined with another standard, the IEEE 802.2, and allows us to work seamlessly with ethernet and can carry the wireless traffic coming from our system easily.

The FCC, Federal Communications Commission, the body responsible for regulating the emission and presence of radio signals anywhere in the atmosphere has a pretty clear and strict law regarding the maximum output power applicable for all devices as well as a subset of standards for devices in the 2.4 GHz channel range.

As a general rule of thumb all devices transmitting any radio signal must have a maximum Effective Isotropic Radiated Power (EIRP) of 4 Watts, this quantity is obtained by adding the maximum transmitted power out of the output amplifier in dB to the isotropic antenna gain also in dB.

Moreover, the standard for all Wireless Access Points (WAP) transmitting a 2.4 GHz signal (also mutually inclusive for all of the devices connected to the network) is 100 mW of total radiated power. The 2.4 GHz is the band of interest because the Wireless Communication module chosen for the design, ESP32, is only capable of connect and provide access points on the 2.4 GHz band.

With that being said, the ESP32 module has the following Wi-Fi radio characteristics:

- Operating Frequency Band of 2412 MHz – 2484 MHz
- Absolute Maximum Output Transmission Radiated Power of 20.4 dBm or 112 mW with a typical radiate power of 19.5 dBm or 89 mW (source ESP32 datasheet)

In addition to this metrics from the ESP32 datasheet the device possesses non-restricted full FCC certification. Its FCC identifier is 2AC7Z-ESPWROOM32D. Even though the flow of data does not end at our device and the ESP32 module is simply a socket or endpoint in the network architecture, the only part of the system where the radiated power creates any concerns is the device itself. The data enters the network and its final destination on the remote server which has its own set of standards, reviewed in the following paragraph on LAMP Server and HTTP standards.

5.2.5 HTTP and LAMP Server Standards

For this part of the standards that we have be looking at, we can look at a list of standards provided to us by Mozilla, who lists many of the standards pertaining to HTTP on their development website. Many of the standards that are based around this protocol are based around the application of HTTP as this is its use in the real world. As the foundation of the world wide web, HTTP is going to be essential in the section of our project that deals with the sending and receiving of data.

Despite the existence of some application-based platforms for IoT protocol implementation and architecture facilitating the data flow and design flow on a given IoT network, we have chosen to create the system network infrastructure from scratch by creating a file system and handling procedures both in the back end and front end.

Since the system controls and data acquisition GUI will be located on a webpage and all of the interactions with the system will occur will rely on the user input, our design of the Web based GUI is based on HTTP standard. Considerations were made to convert the Webpage into a secure one (HTTPS). In our specific case, there is absolutely no sensitive information or Personal Identifiable Information to protect on the data flow.

The system interactions will all be based merely on two types of HTTP requests:

- GET

The GET requests made to the server are used to fetch the page itself as well as all of the redirect links after making POST requests. Alternatively, GET requests can be used in the same way as POST requests to communicate between different frameworks in the LAMP server. However, this method is not desired because it passes the different arguments to different functions through the address bar of the browser which exposes tooo much of the functionality flow of the server.

- POST

This is the type of requests Web Developer are most careful about, this POST request, if allowed in the server, carries the ability to change aspects and the behavior of the server. In our case, this is intentional and a completely controlled behavior where the user is allowed to make a POST request to the server and change certain predetermined files containing the different variables for the

different functions of the system. The architecture and functions themselves are thoroughly explained in section 7.3.7.

6.0 System design

After carefully considering, comparing, and contrasting what parts we have be using and researching into the relevant standards and constraints that will be affecting our design, we can finally begin to talk about the overall design of the system.

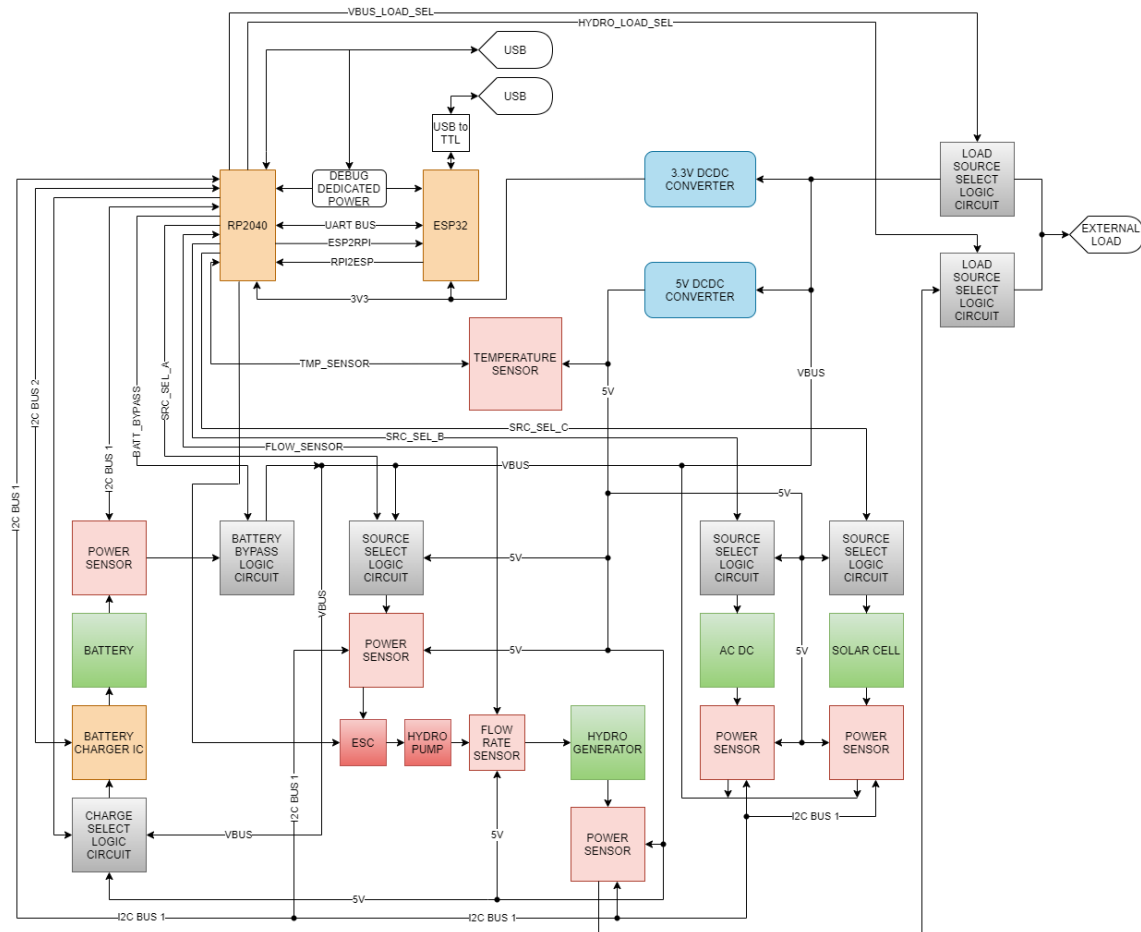

Figure 8: Full System Functional Block

The figure above best depicts the system functionality as a whole at a very high level. Pretty much every function that is related to inputs and outputs is software controlled. The main reason for this is mainly to have full control of the system and to also provide known input states to the logic level circuits present in the system to gate the different power sources and intrinsic functions. Given the changing available power to the system it is very difficult to be able to gate different power signals when their states are unknown at any given moment, therefore various controlled high power, high end MOSFETS are utilized in place. The following sections discuss in detail how these tasks are performed throughout the system.

The system design part of this project includes software and hardware design, as well as the design of the connection of the boards, and the host and peripheral microcontrollers. It is important to note that this design section will be primarily focused on the hardware surrounding our system and handling the data within our system. This is what we would consider the brains of the operation.

The system design part of this project includes software and hardware design, as well as the design of the connection of the boards, and the host and peripheral microcontrollers. It is important to note that this design section will be primarily focused on the hardware surrounding our system and handling the data within our system. This is what we would consider the brains of the operation. In order to have a complete design, both hardware and software will have to be compatible with each other. Through our research, we have selected all components that will be able to complete the tasks we set.

In this section we have describe the system design in an overview format. More details about each function will be shown in greater detail later. The purpose of this section is to show how the system will work under given circumstances. It will also show the full power flow from each source and how they are able to be transferred to the load.

6.1 Power supply design

For this design, the source of power is the most important part. Being able to effectively deliver a constant power supply will keep the system working as intended. Without the power source, all other parts of the system will not operate. The primary source of power, for this design, will be solar. We have used this source in two ways. First, it will be used to charge a battery for later use. Solar comes with limitations in when it can generate power. Take nighttime, or periods of the day where the sun is not in abundance, for example. These time frames make solar energy lose efficiency just by natural causes. Therefore, the battery backup will come into use during these time frames. Majority of the time, the solar panel will be able to both charge the battery and supply power to the load. The solar panel will first be connected to a smart charging system. This system sole purpose is to make sure the battery does not over charge.

Batteries that are not monitored by a controller, have the tendency to overcharge and damage themselves in the process. Once the damage has occurred, either the battery quits working, or can breakdown. This breakdown can then expose the inners of the battery to the environment. Which depending on the type of battery, could have different effects on the outside. Therefore, the smart charging system is very important. The system will also allow for the load to be powered at the same time. Because battery charging doesn't use a high amp rating to charge, there will be enough power to run both. The solar panels we decided to use will be able to output a maximum of 20 watts of energy. Assuming the charger system will require around 4 to 5 watts of energy. This will leave us with a 15 to 16 watts for use for the load.

Originally, we wanted to keep the power output at a 10-watt rating. With some preliminary testing, we discovered that the 10-watt panel would not be able to maintain an effective system. Either there would not be enough to supply to the load, or the charging system will not be able to charge the battery to full capacity. Because keeping the battery at its full amount will be more beneficial when solar energy cannot be used. We decided to increase the power output of the solar panel.

The second form of source power will be the hydroelectric. This type of power will be used during the time frames that solar will not be available. Although, hydro does come with its own limitations. One of them being the need for a constant supply of water. To give the generators what they need, we designed a water pumping system to simulate a constant water stream. Many micro hydroelectric systems are built near a fast-moving stream. This type is more popular in mountain areas. Therefore, we have built a self-contained water system that will always have the amount of available water needed for the generators to operate at maximum output. Without the constant supply of water, the generators will not be able to keep the system running. Just like the solar panel, we wanted to match the power output of them. With this in mind, we decided on running two 10-watt generators. Wiring the generators in series will increase the amount of power supplied. It should be noted that a more stable and reliable system would be to connect the generators in parallel.

However, this would not give us the power output we needed. Working with these values, it was determined that would allow the generators to supply enough power to run any load connected to the system. At this point, we decided to not have the generators feed back to the charging system. It is a possible task that could be installed for future upgrades. Although, we believe that hydro system will supply the 20 watts, there will be a small loss from the generators. One loss comes in the form of energy conversion. This is a natural part of power generation and cannot be avoided. Another loss will come from the pump. Needing a water flow of 126 gallons per hour, the water pump will only be able to supply 120 gallons per hour. This lower water flow will help to improve the system. Looking at how a generator operates; it is never a good idea to run at full output. Generators run by using a rotating part. This part will wear down over time. Also, because we cannot maintain a steady flow of water, due to the properties of the water, there could be a possibility of over voltage. To eliminate this possibility, it was decided to slow the flow of water a small amount. This will still allow us to get close to the maximum output, but not have to worry about extra voltage being pushed into the system.

The use of the battery will be a sole power supply for the water pump used in the hydro generators. In an average solar system, battery banks are used to supply power to a load when solar generation could not be used or is low in the amount it can generate. For this system we have the battery run the water pump. Therefore, decreasing the load amount on the battery and allowing it to supply power for a longer time. The battery will be a lead acid deep cycle rated for solar panels. This battery was chosen for the cost of the system. Using a lithium-ion battery would be overall better for the system.

However, with the current budget constraints, we needed one that would lower the amount needed. In today's market, this type of battery comes at a cost of 17 dollars. While the lithium-ion battery cost close to 500 dollars. Each type of battery has both the same voltage and current output. This gives us the option to use either one. The choice in the battery will cause other choices in the full system. For our system, the battery chosen has a 7.1-amp hour rating. This type would not be suitable for a full-scale system. Because we need the battery to supply power for a full 12-to-14-hour time period. It would be better if we had a battery system with a longer amp hour rating. The lead acid battery does come with some advantages. One being the way it charges, with a smart charging system. This type of battery begins to trickle charge when it reaches a certain percentage. A slower charge will give us a full charge on the battery. Regular, or fast, charging is an effective method of

bringing a battery to full charge in a short time. However, the risk of overcharging occurs when it is allowed to charge the battery all the way to full. Therefore, the system will sense this and slow down the charging amount to make sure the battery doesn't over charge. Although, the lithium-ion battery will be able to do the same affect. A lead acid battery doesn't need as many safety measures in place to make sure this happens.

6.2 Inter-board Communication

In order to develop a system with minimal data loss and to avoid missing any messages from the Host MCU to the ESP or vice versa, in addition to just using the UART software interrupts when transferring messages both the RP2040 MCU and the ESP as a peripheral will feature "Chip Select" data line that will be pulled high if data is being sent to any counterpart on the UART bus.

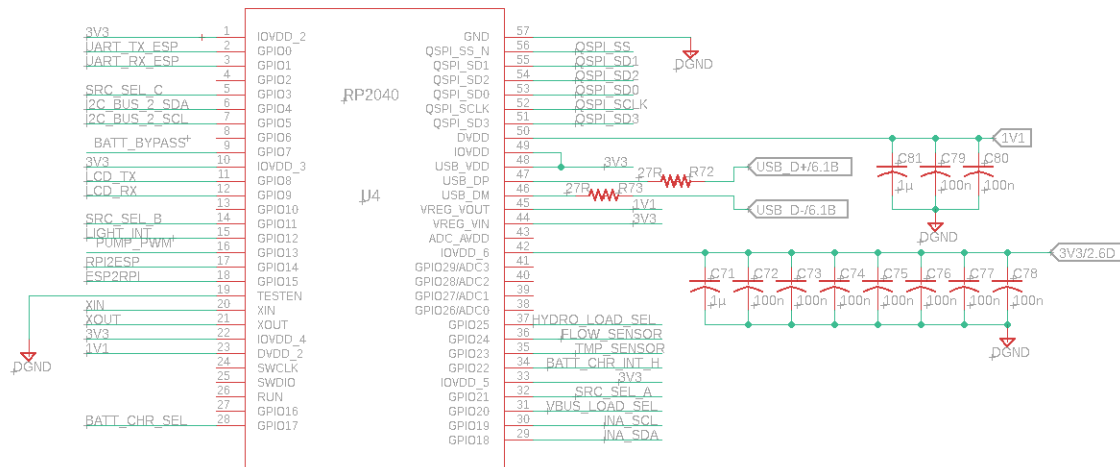
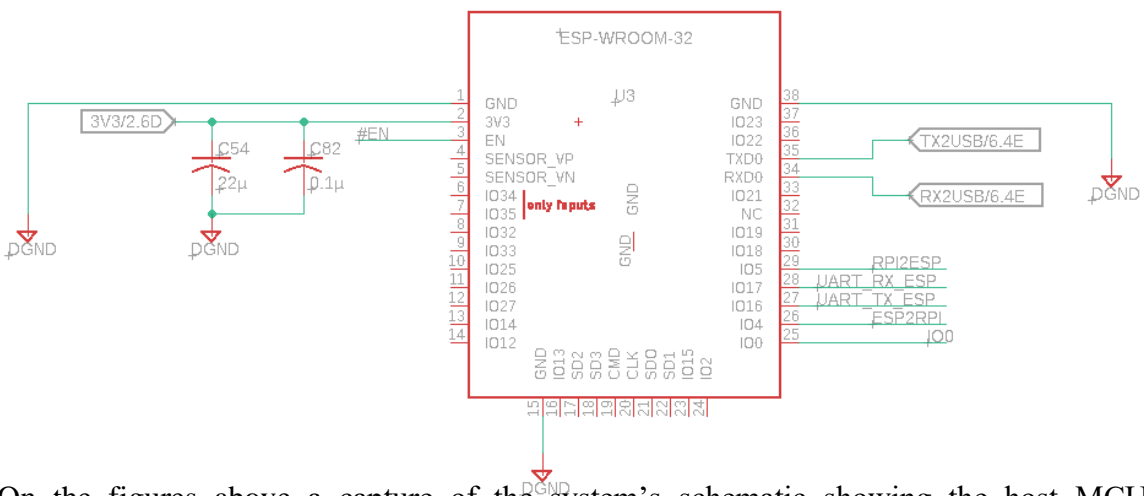

Figure 9: Interboard Communication RP2040



On the figures above a capture of the system's schematic showing the host MCU connection to the peripheral ESP32 and the implementation of the "Chip Select" interrupt interface.
 Figure 10: Interboard Communication ESP32

In this section of the schematic, featuring the Host MCU and our wireless communications module ESP32, the data lines UART_RX_ESP and UART_TX_ESP are the UART host to peripheral serial link and the nets ESP2RPI and RPI2ESP represent the data lines utilized to trigger the interrupts on each device. ESP2RPI is triggered when the ESP32 module transmits data to the RP2040 and RPI2ESP is pulled high when the Host MCU, the RP2040 sends data to the ESP32 MCU. By adding this interrupt feature as well as good software design practices makes the communication link more robust and less prone to data loss.

This interrupt “Chip Select” implementation has been proven to be effective through extensive practical testing of data transfer between Host and peripheral devices and also through examination of waveforms on real time data acquisition as shown on the figure below. This figure represents an interrupt event triggered by the Host MCU (RP2040) sending data over UART to the ESP32 module depicted with the yellow waveform. The

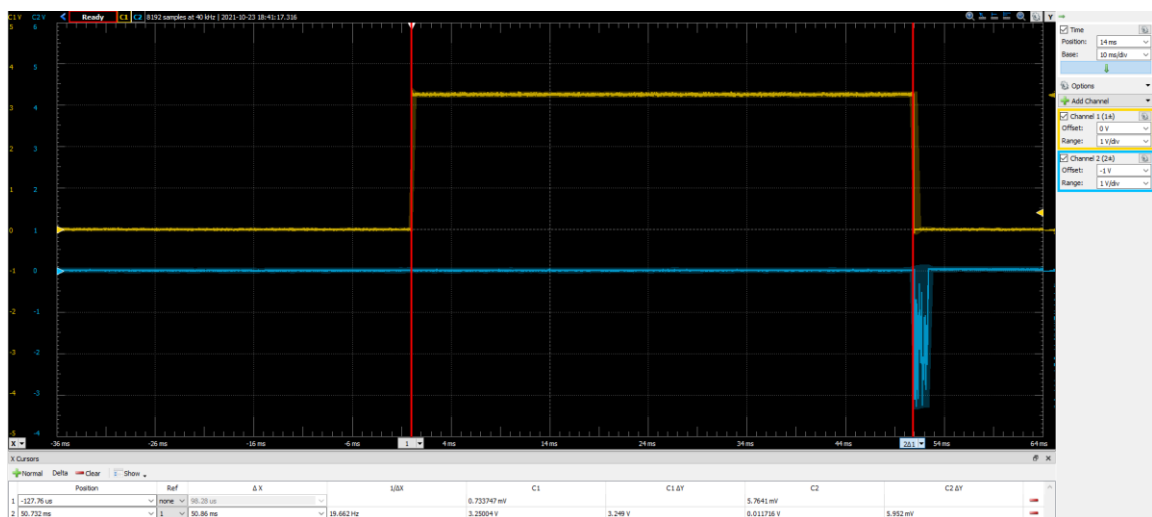

Figure 11:ESP2RPI Interrupt Line

high state indicates the upcoming UART message and has a duration of 50 ms, which was programmed through software in order to allow for the receiving device to stabilize after being triggered by the interrupt and prepare to receive the message.

As observed on the above picture with very low resolution, the blue waveform represents the actual data transmission. Note how the data transmission begins almost seamlessly after the interrupt signal is pulled back down. Again, this feature emphasizes the integrity of the message being received or transmitted by either the Host MCU or the ESP module.

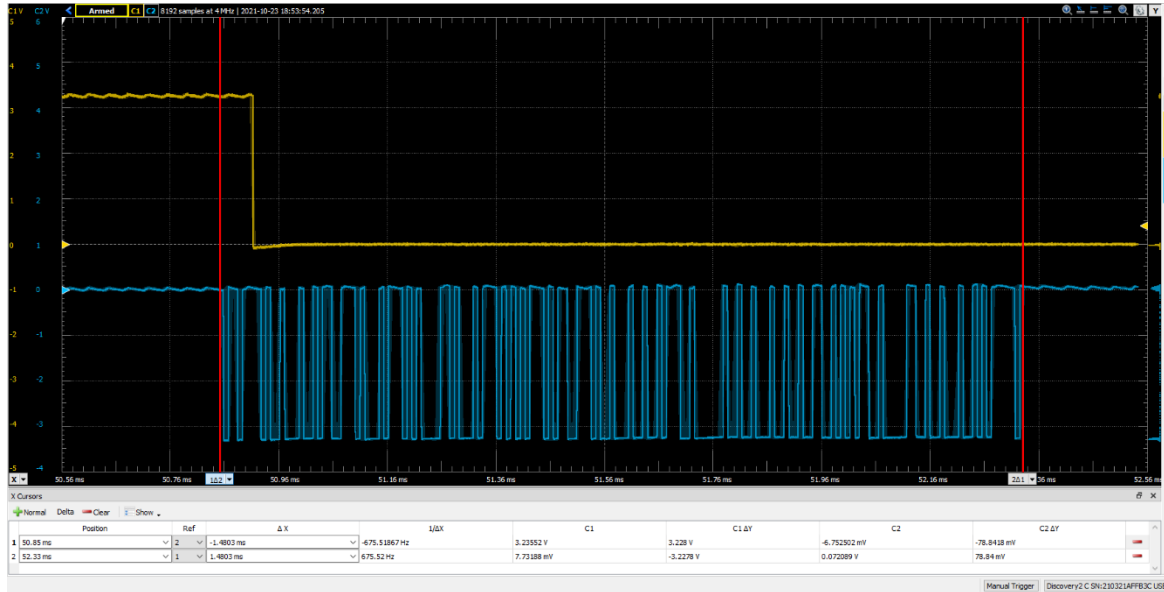

Figure 12:ESP2RPI UART COMM

The data transmission begins about .2 ms after the interrupt line begins to be pulled down as depicted on Figure 8's delta time metric.

6.3 Water pump and load design

The water pump and a basic but important part of the design. Because we are using hydroelectric power, we need to be able to supply water to the generator. Doing so may seem like an easy task, but to get the amount of power needed for the system, certain criteria must be met. One is the water flow. When first testing the system, we used a water pump that pushed 63 gallons per hour across the generators. This caused the generators to only be able to produce up to 5.9 volts. Essentially making the hydro generators only able to produce half of the maximum rated power. The results were not what we were wanting to achieve.

After, some research it was discovered that a flow rate of 126 gallons per hour would produce the required wattage. To meet the flow rate, we decided to purchase a water pump that would push 240 gallons per hour. However, running this much water to one generator would end up in damage to the unit. To prevent this from happening, we decided to use a splitter to decrease the amount of water. This decision also allowed us to operate two generators on the same pump. Because the amount of water we can get from the splitter was close enough to the max we needed, there was little loss of power in this decision. The pump will be a fully submersible style. From here the water will be pumped up to the generators. There will be a return line coming from the generators to the bottom of the container. Doing this prevents the water from becoming aerated and allows for the max amount to be pushed to the generators.

In to make sure our system is working, and to complete the system circuit. We are attaching a load to the power sources. This load will be in the form of lights. Using lights will give a clear and easy method of showing the operating system. Depending on the output of the dc/ac converter, we have size the lights to match. If the decision to not use the DC to AC

converter is made later, then the lights will be LED. Because we are changing the supply power from DC, we have been able to install incandescent lights. These lights have been used in homes for many years. Manufacturing them have been done at a mass scale and the ability to obtain them has gotten even easier over the years. Newer energy saving lights would be the better choice for a full scaled system. However, for this demonstration, we are not needing energy saving methods.

6.4 Controls Design

Now that we have the power supplied and a load connected, we needed a method to change which source would supply the power. At first, we decided on controlling the power using relays. This would have been a viable solution and one that could have been done in the time frame we were given. However, it comes a fully mechanical design. In today's market, many systems are controlled by microcontrollers. This became the focus of controlling the circuit. Microcontrollers are used in all different types of systems. From high voltage to lower voltage, depending on the need of the company. The control system we designed with work with any source we decide to connect to the system.

Let's say the solar system gets to a point where it cannot generate power. Then the microcontroller will read the loss of current and switch the source to the hydro. Once the event occurs, the charging system will be bypassed, and the battery will then send its power to the pump. Then the load will be powered by the hydro generators. Because the system will be changing supply power, there will be a slight disconnection on the load. It is noted that we have seen a loss of power but will quickly regain after only a brief loss. The only way of preventing this from happening would be to install an uninterrupted power supply to the system. This added system would prevent any power loss during the transfer and would drop out once power is restored. For the purposes of this project, an uninterrupted power supply is not needed. If we were controlling safety type circuits, then it would need to be part of the design.

Other functions of the controller will be the battery charging system. This is an important step in the controller's functions. Charging a battery will keep an effective power source, should the solar panels be unable to perform. However, it comes with some risk involved. If we were to allow the system to constantly charge the battery, then the problem of overcharging will occur. This is why we decided to install a smart charging function into the microcontroller. This system will measure the capacity levels of the battery. Once it reaches a certain point it will slow down the amount of charge being sent to the battery. This effect is called a trickle charge. Doing this not only helps to prevent overcharging, but also helps to make sure the battery is charged to a full 100 percent. Then when the battery reaches 100 percent, it will stop charging the battery and indicate that the battery is fully charged. Built within the charging system, will be a threshold to when it will begin charging the battery. If the battery capacity is above this point, the system will prevent it from being charged. This is done to help with the life cycle of the battery.

The controller will be purely software driven. This will remove the need for mechanical relays, that would still preform the same functions. However, they take up space and are more costly then designing a microcontroller. Software driven systems bring many advantages to the electrical systems. One being that they eliminate failure points in the system. Anytime there is an electrical connection, a failure point is created. By using a

software controller, then we can limit the number of electrical connections needed in the design.

Along with the software controls, the microcontroller will have software in place to display current values of the system. We added this function so the user could monitor how well the system is performing. The controller will be equipped with voltage and current sensor chips. These chips will send up to date information to the software. Then the software will be programmed to calculate the amount of power both being supplied and absorbed by the system.

From here will be able to take the power input and output and calculate the efficiency of the system. Along with the sensors, the controller will have a wireless communication chip installed. This chip's function will be to send all the results, from the calculations to a website. This website will be design, where the user can long into from any location and see how well it is performing. As a secondary display, we have also be sending the data to an LCD screen. Here the user can simply walk by the controller's location and take a quick glance. The advantage of the website is that data can be stored and charted for a long-term system analysis. Knowing this information, we allow the user to see where the highest amount of power is absorbed and will give the engineer the ability to adjust the capabilities of the system to meet the need of the user.

6.5 System Testing

In this section, we have tested the major components of the design. Focusing on the solar panel, hydro generators, and the water pump. Determining the working components will ensure that we have have a successful system. If any of the power inputs are not working as intended, then we would need to revisit this part of the system. Although, our research of the components we very thorough. It is still important to verify that they are working in accordance to manufacture specifications. PCB and software component testing will be discussed in later sections. For the initial testing, we have not been able to use our own PCB. This testing data will come later when the board is completed and built. For all control testing, we have been using a stock smart battery controller. Although, this is not a fully desired outcome. After researching the stock charger, it showed that it has all the basic functions needed to begin designing our system. Once the PCB is completed, then it will become an easy transition into the system.

6.5.1 Solar panel

In the initial testing phase, we started with the solar panels. If we were not able to achieve the required amount of solar energy output, then we would not have enough power to operate the system. According to the specification sheet, we should be able to get twenty watts of power. Knowing this output, and the voltage amount, the solar panel current should be close to 1.67 amps. Using a multimeter, we were able to test the voltage rating. Coming directly off the panel it was determined that 11.95 volts was being produced. This panel comes with an amp draw of 1.61 amps. Giving it a total produced power rating of 19.24 watts. It is expected for the outputs of the panel to be lower than the manufactures specs. There are a few environmental factors that are not present in the testing by the company that made the panel. Therefore, it is not uncommon for components to be slightly under the

values from the specification sheet. However, it is not at a point where it would determine that the component was not operating properly.

Now that the basic testing is complete, we wanted to see how the panel would operate over a longer period of time. This would be difficult without the use of the software called system advisor model. Using this software, we gain access to Pvwatts. The next step was to select the wattage output of the panel we want to test. This program will also allow us to add in updated power prices for cost comparison. This would show how much a full-scale system would save the average homeowner. However, for this purpose, we have been using the software to determine the energy production for month to month and the time of day in which the panel works at a higher efficiency. It is important to note, that the software keeps the standard power rating in kW. Therefore, when selecting the power output, the value inputted would be .02 kW.

Adjusting the weather patterns and power prices to Orlando, Fl., we were able to determine the yearly amount of power that is to be generated. According to the results, the panel should produce 31 kWh per year, with a capacity factor of 17.8 percent. This result is close to the manufacture capacity factor of 23 percent, given that we did not set the environmental settings to the same area. The test results also showed that the months of March, April, and May. Where the best months for energy production. Other months were not too far off from these three. During the peak three months, the panel would generate a monthly output of 3 kWh. The lowest month, February, had an output of 2.2 kWh. Using the generated chart, it was determined that the panel would output an average of 2.7 kWh. Next, we were able to determine the best hours of the day that the panel would operate at the highest efficiency. Between the hours of 10 am to 3 pm, became the best time. During this time, it is proven that the panel will be able to effectively run the load and charge the battery to full.

Two factors appeared from using the software. This was the life span of the panel. Over time panels lose the ability to generate power. By adding in a standard degrading factor in the software of .5 percent per year. We were able to see that in 25 years, the panel will be able to provide the system efficient power. By the end of the 25-year cycle, the panel will be able to produce 27.5 kWh. Although, this is about 5 kWh drop, it still is enough generation for the system to work as intended. The second factor is the price per kWh. Power companies charge customers based off how much it takes them to generate the amount of energy needed. Using the standard data, the software was able to determine the levelized COE to be 8.41 cents per kWh. This means that the panel would cost 8 cents per hour to generate electricity. Adding in locational data, our panel will be able to produce energy at a rate of 6.72 cents per kWh. This data will be useful in marketing the design to potential customers.

Metric	Value
--------	-------

Annual Energy (year 1)	31 kWh
Capacity Factor (year 1)	17.8%
Energy yield (year 1)	1,559 kWh/kW
Best months	March, April, May
Best Time of Day	10 am to 3 pm
Life cycle	25 years
Levelized COE (nominal)	8.41 cents/kWh
Levelized COE (real)	6.72 cents/kWh

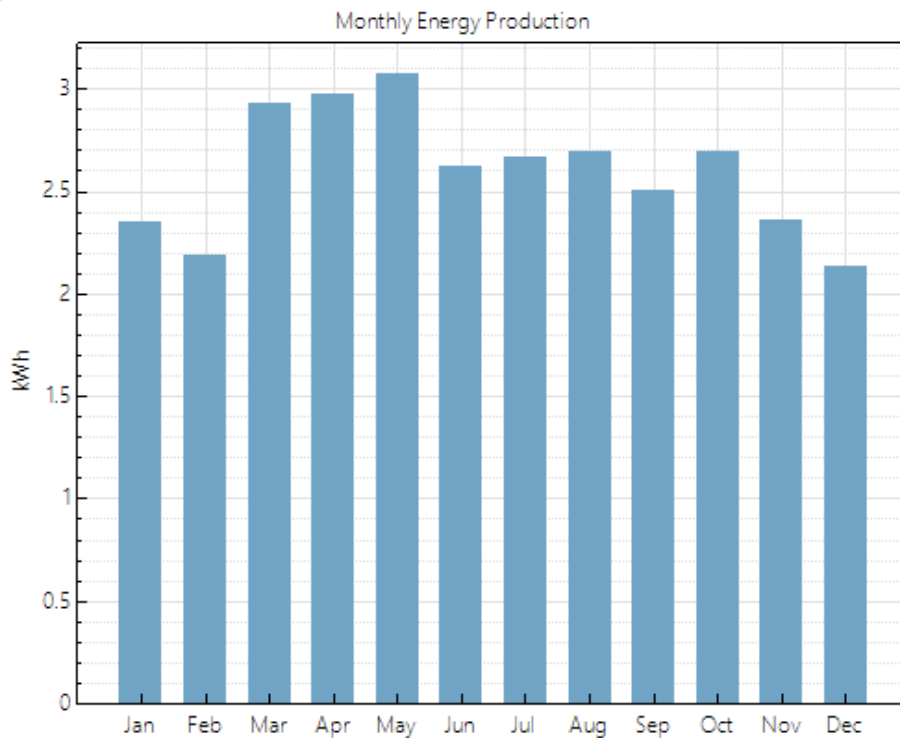

6.5.2 Hydro Generators and Water Pump

Due to the nature of how a hydro generator operates, we decided to test both components at the same time. First, we started with the water pump. From our previous testing, using a smaller pump, we needed to make sure the pump was pushing a minimum of 126 galleons per hour across the generators. This water flow must be achieved with a 12v pump. The pump that was chosen does have the ability to vary the output by the voltage inputted into the pump. Keeping the pump at a 12-volt input, for power consumption, the pump should output 240 galleons per hour.

Because we are using a battery to supply voltage to the pump, there shouldn't be a fluctuation of voltage. Therefore, giving us a constant 12 volts supplied to the pump. Applying a voltage meter to the incoming wires, proved that we did indeed have a constant voltage supply. After connecting the splitter to the water pump, we then added two water flow sensors in the path to each generator. Watching the water pump for a total of 5 minutes. The flow rating did fluctuate, but it was not by a large amount. This change was due to how the splitter separated the water. It was assumed that it would keep the system at a constant flow rating. However, it was the average that help to keep the system in proper working conditions. From the water sensors, the flow rating would run between 118 to 123 galleons per hour. This was an expected outcome.

From our initial research, it was understood that the amount of water flow needed was supposed to be around 126. This would require the pump to push 252 galleons per hour, in order to meet the requirement. Although, the pump does not provide the required amount of water. There is still an adequate amount of water, which will then generate enough power for the system to operate.

Because we already had the system set up to test the water pump. Testing the hydro generator was an easier task. We achieved this task by applying a voltage meter to the red wire of the first generator and the black wire of the second generator. In low voltage DC circuits, the positive, or hot, wire is standard to be red. The negative side of the system is standardized to be black. In order to make the system generate 20 watts of electricity, the two generators had to be wired in series.

Doing this, the voltages are added together and therefore double the amount of power needed. Current should remain the same throughout both generators. Connecting the multimeter in series we have been able to read the current rating of both generators. There is no need to add a load to the generators because the meter already comes with a 1000-ohm resistor built inside. From here we were able to read an ampere rating of 1.46 amps. The next step is to switch the meter to test for the voltage of the system. We already are aware that the voltage will be lower than it is rated for. Mainly because we are not pushing the full volume of water needed for the generators to run at max output. With this in mind, we were able to get a voltage of 11.85 volts. When we apply both the current and amps into the power equation, we get the total power output to be 17.3 watts. Although, it is not the full 20 watts we were attempting to achieve, the power output is still sufficient enough for the system to operate.

6.5.3 Battery Testing

Testing on the battery comes in two stages. The first stage is simple, it is to check that the battery is producing the proper amount of voltage. For this system we chose a 12-volt battery. Therefore, we should see this voltage when we place a multimeter to the positive and negative terminals, or at least close to it. For the battery we selected, it was shown to have a voltage of 11.7-volts. There are some unseen reasons to why, the voltage is not working at the full amount. Although, this will lower the amount of water the pump will be able to push, it still isn't enough to keep us from adding it to the design.

The second part of the testing is to make sure the battery will recharge. In order to achieve this task, we put a small load to the battery. Then using the smart charging system, that came with the solar panel, we have checked the voltage before and after charging. After using

the battery for one hour, we tested the capacity percentage. From our results, the percentage was at 83 percent. This is sufficient enough to cause the smart charging system to engage. After applying the solar panel to the charging system and connecting it to the battery. The LED indicator turn on. This shows that the system is attempting to charge the battery. We waited for the system to turn the LED off, showing that the smart charger had full charged the battery. We then tested the battery capacity again. From the results of this test, we saw that the system was at 98 percent. With this test it was determined that the rechargeable battery was able to be charged to a certain percentage. If we wanted to charge the battery to 100 percent. Then a trickle charge system would have to be implemented. This type of system would slowly charge the battery till it was fully charged.

It is important to note, that for the battery test we used a stocked smart charging system. For design, we have be building out own smart charge system onto the PCB. This will do the same functions as the stock charger. However, for our initial testing, the PCB had not been built and we did not want to stall the design process. We have full confidence that we have be able to recreate the same results with our smart charger.

6.5.4 Power source switching testing

Switching from one power source to the other, is one of the main functions of this design. Therefore, it is important to make sure the components we chose are able to complete this task. Again, using the stock smart charging system, helps us complete this task until our own design is completed. On the stock charger, it comes with a dawn to dusk function. This means that we can run a load from the solar panel and still be able to charge the battery at the same time. Then when the sunsets, it will switch power from the solar panel to the battery. This is the point where the hydro generators will then take over responsibilities for the supply power to the load. However, there are still some limitations to what the stock charger can do. One of them being if the solar panel cannot produce sufficient energy. With the stock charging system, it will simply stop charging the battery and supply power to the load. The system we have be designing, will be able to complete this task. Therefore, in the initial testing phase, we have been unable to see if the system will transfer the responsibility of power for weather conditions. There are smart charging systems with the ability, but in order to have this function. The cost of ordering it, would out way the need for it. Mainly cause we are designing out system that will perform this function.

For testing this function, we simply connected a small load, light bulb, to the output of the stock charger. From here, we have been able to watch if the power responsibility will change when we need it to. Doing this test did wait until the sun was beginning to set. Once the preset time in the charger was reached, we saw that the battery then took over responsibility of supply power to the light bulb. In our design, there will be other ways the solar panel cannot supply power, that will need to be tested. Until we have finish building the PCB, this test will have to be sufficient enough for us.

6.6 Main Functions Testing

For this section of our design, we have been using various means of testing the main functions we have be using in our project. We have gone over what they do and how exactly we have been testing them in their individual parts.

6.6.1 Discrete Input & PWM Control

In this section we have been discussing the major functions of the system that are either controlled by software or are intrinsically present in the system by firmware configurations or circuit design. Additionally, we have also tested the built-in AC to DC converter for ripple and turn on stabilization time.

The main purpose of performing these tests is to ensure that the components selection actually do fit and conform to the behavior expected given the anticipated signals amplitude and frequency.

We have first gone over the circuit displayed on Figure 17, which is largely used over many functions in the system. The purpose of this circuit is the control of the different functions, whose signal amplitudes may vary, by the standard 3.3V logic. The testing of this circuit will be a two in one test. We have been using the preliminarily developed webserver to control the “pump” (a brushed motor of similar IV characteristics in this case). This test will not only validate the step response of the circuit when given discrete 1 single bit inputs but will also validate the Pump PWM control low side circuit. Despite the PWM control using only a NMOS FET, PWM control can also be achieved using the NMOS – PMOS RTL logic used in the other circuits.

First we provide an input to the Webserver as seen below:

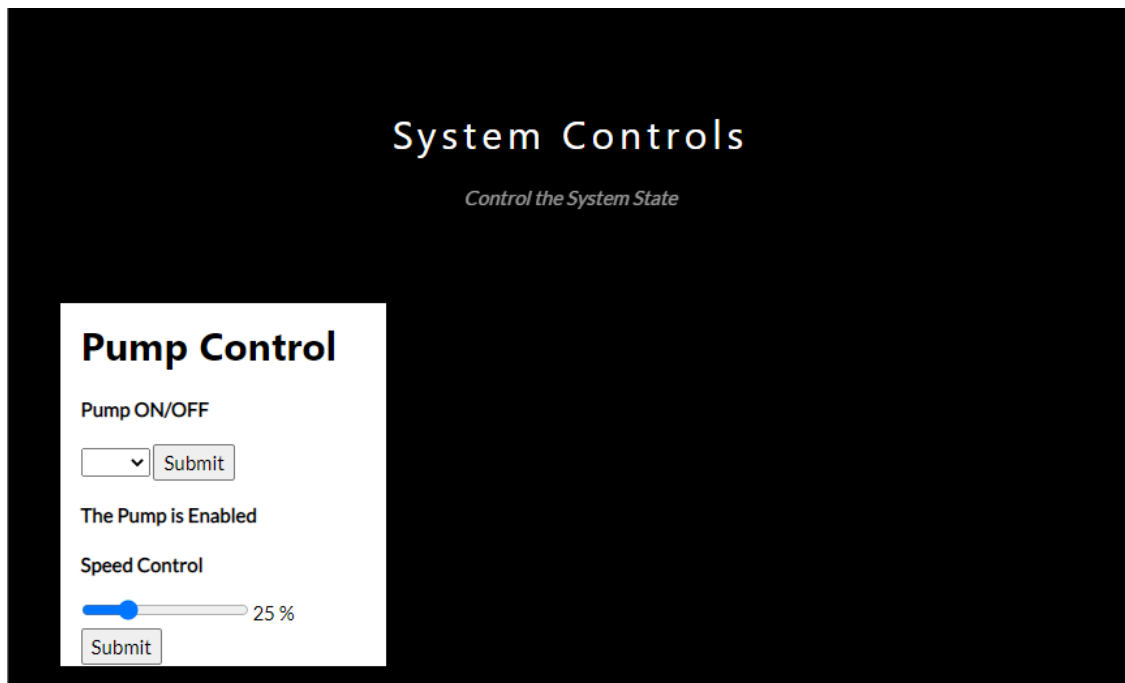

Figure Page Layout Systems Controls

The drop down menu next to the “Submit” button has the options to turn the Pump on or off. The logic on the webserver is built in such way so that if the pump is “OFF” or disabled, the speed control bar will not be able to be altered.

In this case, we turn on the pump, and then we move the speed to 25%.

Below is the Server Access log in which we can see the Post request made by the user to change the motor speed. Then a GET request to redirect the user to the main page.

```
184-089-250-140.res.spectrum.com - - [28/Nov/2021:15:03:15 -0500] "GET /pump_pwm_stat.config HTTP/1.0" 200 223 "-" "-"
184-089-250-140.res.spectrum.com - - [28/Nov/2021:15:03:16 -0500] "GET /pump_pwm_stat.config HTTP/1.0" 200 223 "-" "-"
192.168.0.155 - - [28/Nov/2021:15:03:17 -0500] "POST /pump_pwm.php HTTP/1.1" 302 249 "http://192.168.0.189/index.php?st
ke Gecko) Chrome/96.0.4664.45 Safari/537.36"
192.168.0.155 - - [28/Nov/2021:15:03:17 -0500] "GET /index.php?status HTTP/1.1" 200 4645 "http://192.168.0.189/index.ph
, like Gecko) Chrome/96.0.4664.45 Safari/537.36"
184-089-250-140.res.spectrum.com - - [28/Nov/2021:15:03:17 -0500] "GET /pump_pwm_stat.config HTTP/1.0" 200 225 "-" "-"
184-089-250-140.res.spectrum.com - - [28/Nov/2021:15:03:18 -0500] "GET /pump_pwm_stat.config HTTP/1.0" 200 223 "-" "-"
184-089-250-140.res.spectrum.com - - [28/Nov/2021:15:03:18 -0500] "GET /pump_pwm_stat.config HTTP/1.0" 200 223 "-" "-"
```

Figure Server Log Activity Before and After Request

On the following figure, a scope capture with time stamps for the control of the “Pump” on the system is displayed.

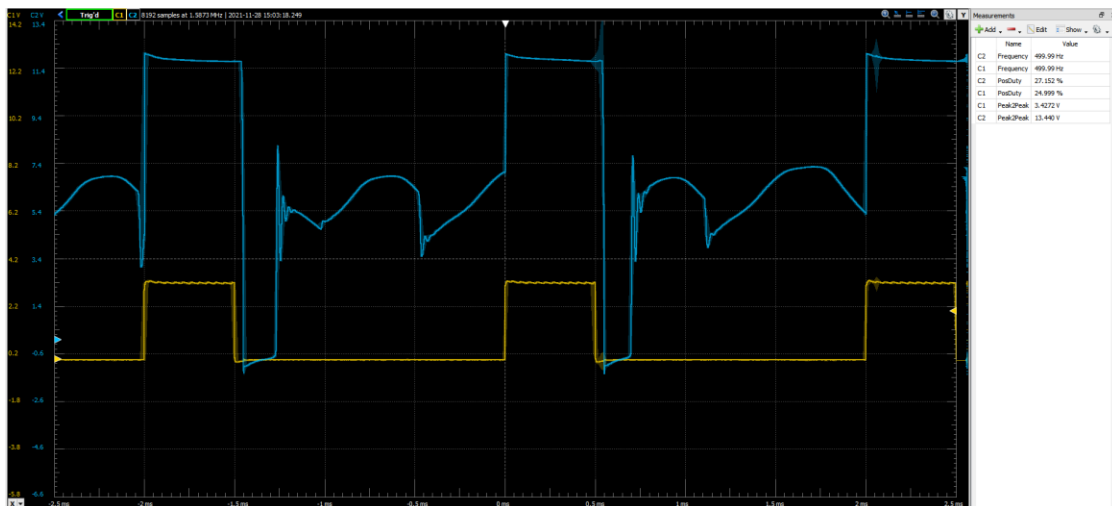

Figure Pump Control PWM signal vs GPIO PWM signal

On the figure above, the blue waveform represents the signal input to the motor. The yellow waveform depicts the raw GPIO PWM signal output. More interestingly, if close attention is paid to the Server’s POST request timestamp, the time the user made the request to operate the pump is 15:03:17 and the timestamp for the scope capture is 15:03:18 meaning that the response time of the system is less than once second (scope view was set to continuous, so the signal start occurred a few fractions of a second before the capture). Moreover, we can validate that the appropriate duty cycle was relayed by looking on the measurements windows and seeing the “24.999%” positive duty cycle from the GPIO pin. On another note, what is observed on the motor’s waveform (blue) in between the “On” state and the next cycle “On” state is the inductive loading response of the motor along with vibration distortions. For this example a Frequency of 500 Hz was used to drive the motor, it is yet to be seen the best performing PWM frequency once the actual component is used in order to minimize losses, noise and distortion.

6.6.2 AC to DC Circuit

The ability of the system to charge the battery from the only source available for this kind of operations (Solar Cell) is limited by being able to provide natural light to the system or not. It is also limited by the battery having some charge in it in order to run the digital source selection algorithm on the MCU.

This is why the inclusion of a built-in AC to DC conversion circuit is imperative so that in situations where energy is available at a low cost or no cost, the system can also be charged that way.

The following testing data corresponds to the circuit outlined in section 6.3.3 regarding AC to DC power conditioning. Specifically the following figure pertains to the ripple voltage measurements on the AC to DC converter Circuit.

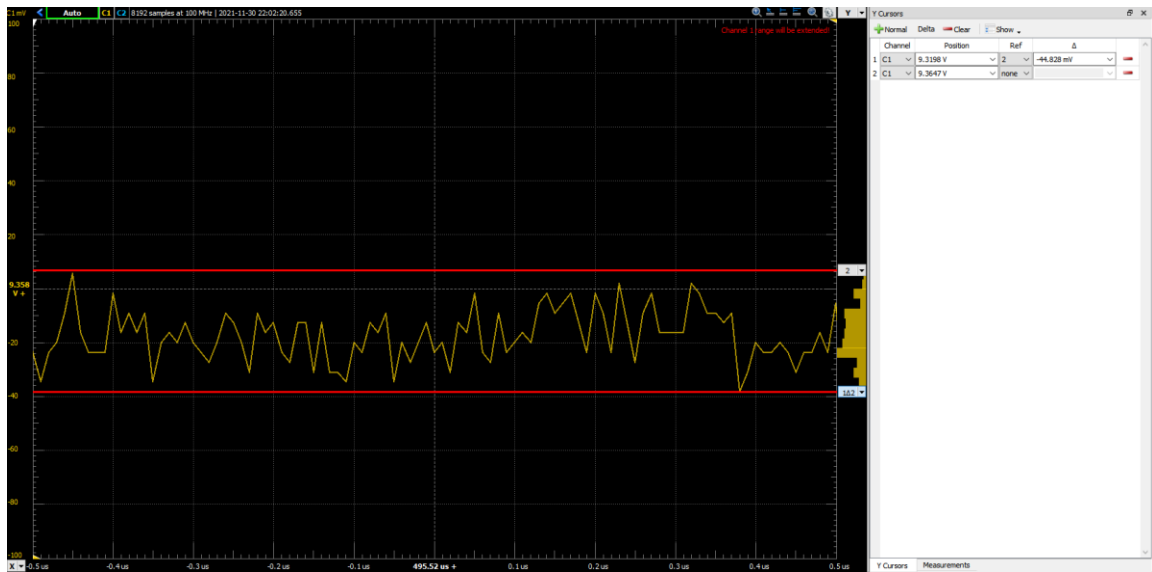

Figure AC DC converter Ripple Voltage

As we can observe through the cursor measurements on the waveform and on the measurements window the maximum ripple voltage observed is under 50mV, about 45 mV to be specific. The “ π ” filter implemented in section 6.3.3 has a cut off frequency of 73 Hz. The π filter naturally behaves as a low pass filter. Given that the standard expected frequency of the Alternating Current signal input is 60 Hz. The cutoff frequency is calculated using the following formula:

$$f_c = \frac{1}{2\pi\sqrt{L \cdot C}}$$

All of the components utilized on the AC DC conversion circuit are rated for the maximum expected current and voltage out of the transformer.

7.0 System Power Sources / On System Indicators

As discussed in the opening section for this chapter, one of the main features of the system is to harness full control over a range of sources and power inputs and outputs, it is why we introduce various sensors and metrics gathering devices to maintain full accountability of the power availability within the system.

7.1 Power Sources & Power Selection

The current design of our system features two native power sources and the possibility of an external power source of household standard, i.e.: 120Vrms. Given the unpredictability of the available sources our design needs a solution to select from the available power sources based on real time measured data. I.e.: time of the day , light intensity and the presence of AC input power in order to enable the specific power source. Future revisions of this design may include multiple power inputs if it is at all feasible. The system shall also bypass the battery charging circuit and provide power to the native functions of the system simultaneously without interfering with the battery charging output. The inability of isolating the system load from the battery while it is charging can potentially create a hazardous condition given that the battery charger IC senses as if the battery was never actually charged because a load is connected to its output while it is trying to charge the battery. With these design considerations in mind the following circuits have been developed and specifically tailored to provide all of the system needs while also remaining in a safe condition.

7.1.1 Power Sources and Sensing

Part of our system requirement is the constant monitoring of the system metrics such as the power being generated, and power being consumed by all applied loads. All of these requirements were able to be fulfilled by part selection on the INA260, power IC.

INA260 by TI is a high precision power monitoring IC with a 16-bit ADC able to interface with our Host MCU by I2C protocol. This sensor also features a very low impedance which is the equivalent of almost invisible for the nets it is connected to and crucial for the system's efficiency. Because of the design's current power selection architecture, there is one INA260 sensor needed per source to gather metrics in regards to the power source active at a given moment, because of the fashion in which the power sources are connected to the VBUS power rail, the power sensors in some instances such as AC IN power is the only way to detect the presence of the source and the firmware takes the decisions specified in the system's flow chart to harness the available power source.

Only one source is connected to the rail at a given time and its connection is selected by software, meaning that at any given time the firmware is fully aware of the current power source supplying power so that way it can be labeled and forwarded to the database. In addition to this power sensor connected to the main power input line present another INA260 sensor shall be placed in series with the supply power to the pump in order to know the ratio of power inputted to the pump versus the power outputted by the turbine. Therefore, another instance of the circuit shown below will be implemented to sense the power inputted to the turbine, specifically in series with VBAT and VTUR.

Below is the circuit utilized in our design for gathering data. In total, there are five instances of the circuit one for each power source including the battery as well as one for in order to sense the power being inputted to the water pump.

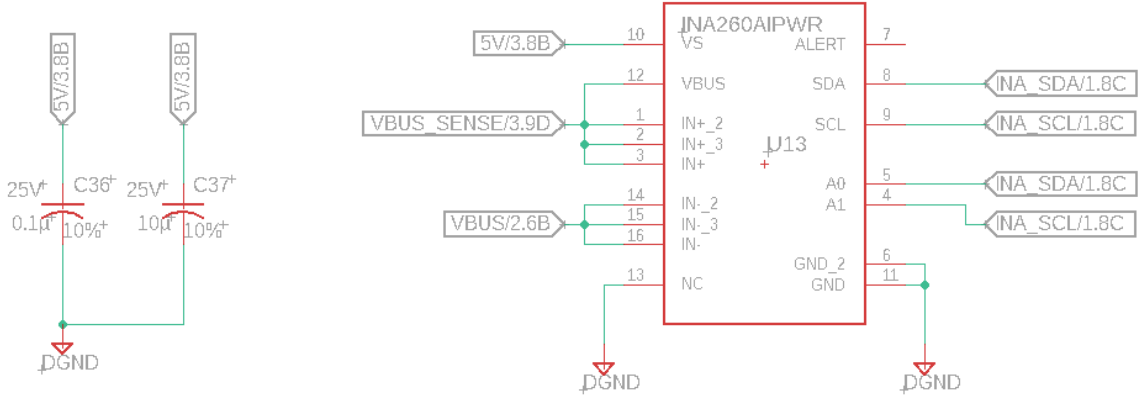

Figure 13: Power Sense Circuit.

7.1.2 Battery Bypass Circuit

As mentioned on the section opening paragraph, charging the battery while also having a load drawing current from the battery can cause hazardous conditions due to the fact that the battery management system will sense the battery is never fully charged and continue to provide current depending on the load. Truth is, in fact the load is always connected to the battery in all instances in order to provide seamless power supply to the native functions of the system. However, the design requires a way to eliminate this direct connection while the battery is being charged. For this reason, we have employed the following circuit depicted in the next figure.

Although this circuit topology was discontinued for use in bypassing the battery, it is still useful for applicable for scenarios where the voltage BATT and V_SRC with respect to ground are equal. Therefore, it was utilized for the In-System Programmability features of the system.

Components Selection

STD10P10F6

The circuit's architecture requires a configuration where the battery (BATT) is always connected to the main supply rail for the voltage regulators and only be interrupted in case of the presence of any of the native power sources or the native power source. A P-Channel FET is the perfect solution given that the drain to source channel is always conductive unless the gate is biased above $V_{gs(th)}$. Below is the table of absolute maximums extracted from the device's datasheet:

Symbol	Parameter	Value	Unit
V_{DS}	Drain-source voltage	100	V
V_{GS}	Gate-source voltage	± 20	V
I_D	Drain current (continuous) at $T_C = 25\text{ }^\circ\text{C}$	10	A
I_D	Drain current (continuous) at $T_C = 100\text{ }^\circ\text{C}$	7.5	A
$I_{DM}^{(*)}$	Drain current (pulsed)	40	A
P_{TOT}	Total dissipation at $T_C = 25\text{ }^\circ\text{C}$	40	W
T_{stg}	Storage temperature	-55 to 175	$^\circ\text{C}$
T_j	Max. operating junction temperature	175	$^\circ\text{C}$

Table 14:STD10P10F6 Parameters

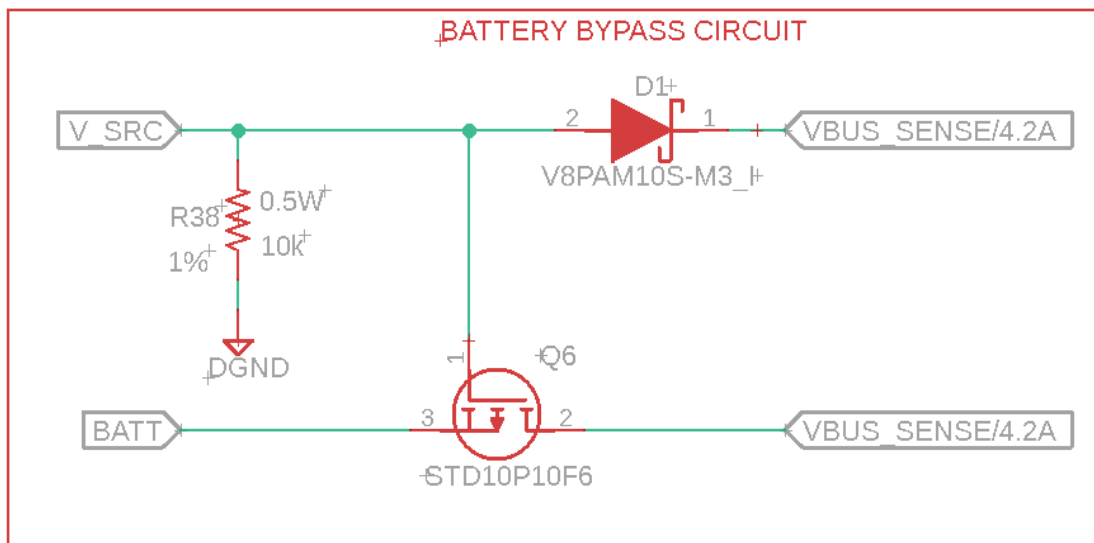

Figure 14:Battery Bypass Circuit

With a I_{ds} max of 10 A this FET meets and exceeds the maximum current expectations that can be drawn from any of the sources while simultaneously allowing the max voltage to be present and having a big leeway. A medium R_{ds} value of $0.18\text{m}\Omega$ is low enough to minimize losses but it is less important given that the switching frequency will be close to zero, as sources will not be switched often enough in order for this parameter to make a difference.

V8PAM10S-M3/I

The reason for selecting a Schottky Diode in this circuit is the isolation of the VBUS with respect to the P-Channel FET's gate to avoid triggering the gate when not intended, i.e.: not in the presence of any other power source other than the battery. because of its low dropout characteristics in order to minimize losses and voltage drop when bypassing the battery from the source.

7.1.2.1 Battery Bypass Circuit Revision

The circuit topology shown in Figure 12 does a good job at gating any given power source on Q6, but only with one condition, the expected voltages for every source on the gate and source pins of the PMOS FET need to have virtually the same potential difference with respect to ground ± 1 or 2 volts in order for the FET to trigger. In our previous design the STD10P10F6 PMOS possess a max $V_{gs(th)}$ of $-4V$, in a case where there is no source applied to the gate of the PMOS current flows flawlessly through the V_{ds} node.

However, in the event of the minimum voltage is applied to the gate pin of the FET and let's say the battery is at 50% with a nominal voltage of 12V and it is desired to charge the battery some more or feed the load demand from the system or external loads from one of the power sources the FET will not trigger and it will still be under the threshold voltage. For example, in these two cases where $V_{batt} = 12V$, $V_{src} = 0V$, $V_{gs} = -12V$ FET is on and it is feeding the load from V_{batt} . In the case where $V_{batt} = 12V$, $V_{src} = 7V$, $V_{gs} = -5V$ which is still over the threshold to maintain the FET on.

This is the reason why the following topology was implemented which uses two PMOS FETs and in this case the signal triggering the activation or deactivation of the battery as a the main power source is an active high software controlled GPIO signal fed directly from the Host MCU.

In this case, this topology uses a clever approach in which the Battery signal is fed to the Source pin of both FETs, in addition, the gate of the GPIO receiving FET is pulled high to the Battery signal node that whenever the GPIO signal is not fed, the gate and source voltages are equal and therefore $V_{gs} = 0V$ (about). The figure below shows the redesigned Battery Bypass Circuit, where the PMOS FETs used are the logic level FDB9503L-F085 by OnSemi with a max $V_{gs(th)}$ of $-3V$. The topology below along with the subsequent equations and simulations demonstrate the functionality of the circuit.

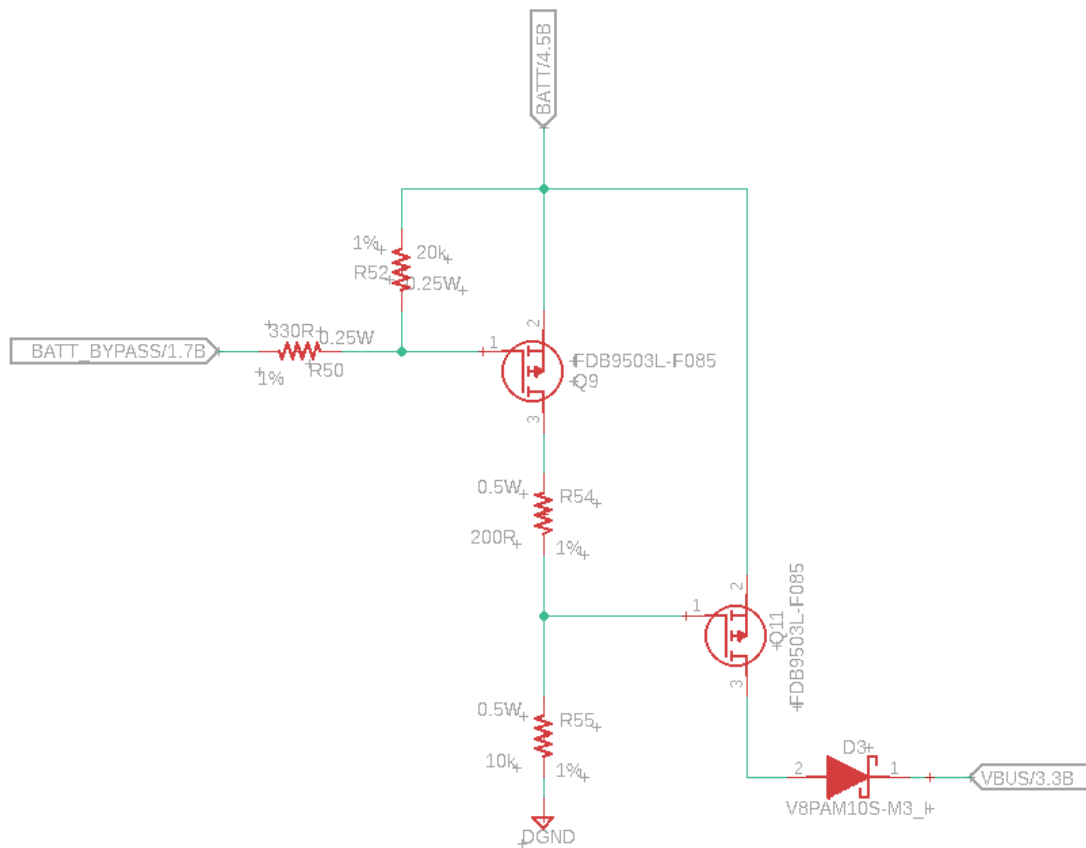

Figure 15: Modified Battery Bypass Logic Circuit

Whenever the GPIO signal of logic level 3.3V is applied to the gate, the transistors V_{gs} is governed by the following equations:

$$\frac{V_g - V_{gpio}}{330} = \frac{V_g - V_{batt}}{20k}$$

Where V_g is Q9's Gate pin voltage V_{gpio} is the logic level signal @ 3.3V fed from the Host MCU, and V_{batt} is the actual battery voltage feed to the Source pin of Q9 at any given point, for these calculations let's assume V_{batt} to be 12V and V_{gpio} to be 3.3V.

By solving for V_g we obtain that $V_g = 3.154V$. By doing a KVL with respect to the Source pin of Q9 we find that $V_{gs} = -8.84V$ which is well above the required threshold to turn the transistor on, conducting from source to drain almost the entirety of the V_{batt} voltage available, making the gate voltage equal to V_{batt} and therefore turning Q11 off, since $V_g = V_s$ in this instance.

7.1.3 Power Source Selection

The original idea for the design controlling the source's output by utilizing mechanical relays. However, given the nature of the project in terms of the amount of power being managed, as well as the expected load demand, our team decided to shift from using relays

because of a cost effectiveness, size and the ability to manage the sources using discrete electronic components with logic level input.

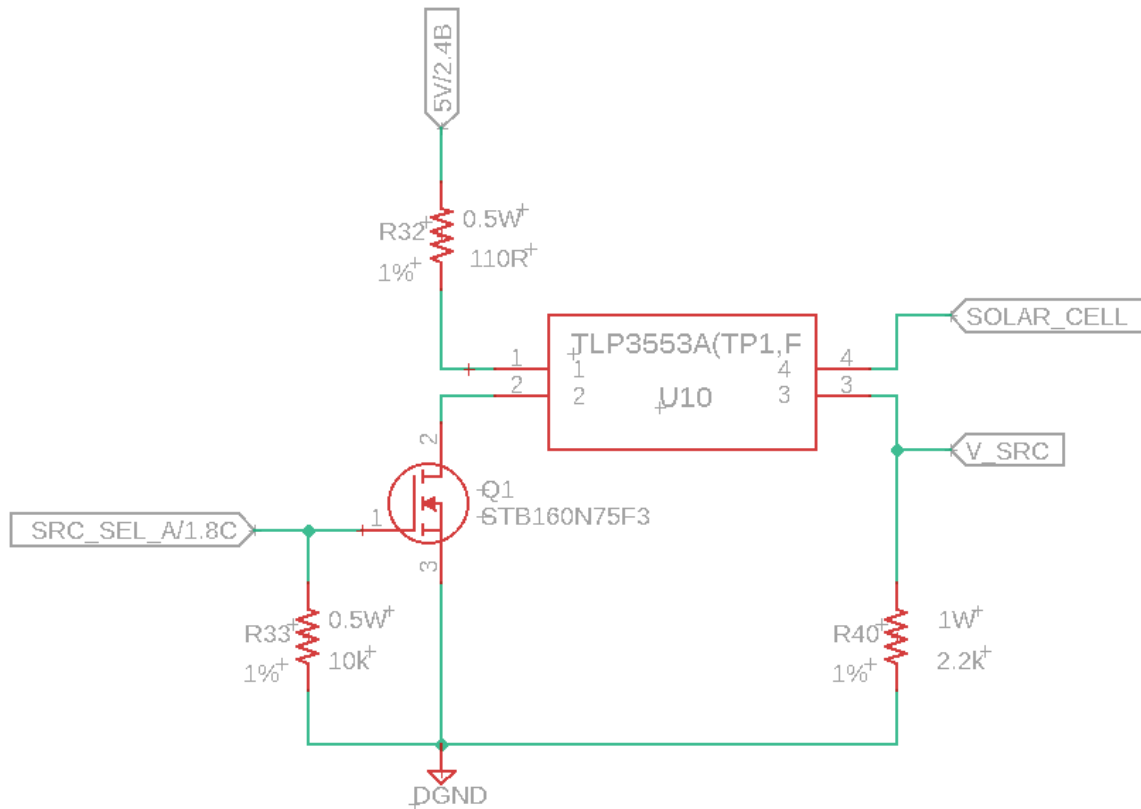

Figure 16: Source Select Logic Circuit

Instead of mechanical relays, the use of optocouplers paired with N-Channel FET transistors will be used for extra isolation. The following topology uses an active high configuration on the optocoupler (TLP3553A) with the pull-down resistor R40 and the output connected to the emitter side. The FET, Q1 receives input to the gate from the Host MCU through the signal SRC_SEL_X. The gate resistor selection limits the current being drawn from the GPIO to the order of $<200\mu\text{A}$. There are three instances of this source, one per source, AC IN, Hydro PWR and the solar cell and the selection is software controlled. Given the FET's $R_{ds(on)}$ parameter at a max of $4\text{m}\Omega$ a 110Ω resistor is used in order to bias the optocoupler LED input to about 28 mA, (30 mA max) in order to ensure its triggering. The emitter resistor R40 is low enough to ensure max voltage to the parallel outputs and high enough to ensure max voltage acquisition.

7.1.3.1 Power Source Selection Circuit Revision

In spite of the ongoing semiconductor shortage caused by the still in effect COVID19 Pandemic, parts availability tend to fluctuate quite often and stocking on mainstream electronic component suppliers is very volatile. It is our mission to deliver a feasible product with realistic goals and realistic components selection based on short term lead

times (<2 months) in order to purchase the parts and realize the design. It is because of this reason that the Power Selection circuit had to be redesigned utilizing available components.

On the other hand, the optocoupler circuit shown in the first version of the power selection circuit was very temperature dependent and at the max anticipated temperature of 70 C the Collector-Emitter current on the output side would have been degraded by over 2A. This is very significant given that the max current achievable is 4A on the output side, a very low margin for the anticipated load demand from both in-system and external loads. With the circuit implementation shown in the figure below, the max amount of current that can be fed through the pass-thought is at tops 110 A.

The only tradeoff is that now the selection of any power source as well the battery bypass functionality discussed in section 5.2.1.2 is now software controlled. The figure below depicts the new circuit in place to achieve this functionality. Aside from not using the optocouplers IC's we have also decided to utilize a logic level N-Channel FET, in order to ensure the triggering of the signal with 3.3V logic.

The reason for this topology is the desire to implement a "High-Side FET Switch" which is present on Q8, basically the Voltage from the Source side of the FET is fed to VBUS with respect to ground. On a low side configuration, the High potential is always fed to the load and the FET, when triggered, completed the circuit to the Ground signal.

The Role of R43 is a current limiter in order to prevent any overload to the GPIO pins of the Host MCU, without R43 whenever a voltage is applied to the gate of Q6 the load on the GPIO (SRC_SEL_A signal) is of several Amps very momentarily because the gate acts as a capacitor whenever it is discharged, but even a short duration current draw like this can still damage the MCU.

The purpose of R45, is of a "Gate Resistor" and it simply brings the gate down to Ground whenever a voltage is not applied the gate of Q6, therefore bringing the FET to an "OFF" known state. Q6, being a logic level NMOS FET has a max $V_{gs(th)}$ Gate-Source Threshold voltage of 3V. Because the Source terminal of Q6 is tied to ground, whatever voltage is applied to the Gate terminal with respect to ground is the Gate-Source Voltage, ensuring that every time a high state signal with logic level of 3.3V is applied to gate the FET will conduct from drain to source, putting the Gate terminal of Q8 at almost a Ground state, limited by the $R_{ds(on)}$ resistance, which in our case has a max of 2.9m Ω at the max temperature profile, in series with the gate to source resistor of 1k Ω on Q8 ensuring a low current is drawn from the source in order to perform this task. On the other hand, in order to ensure that the source voltage is gated on Q8 whenever Q6 is not triggered the following calculations were performed along with simulations validating the data and the decision to use this topology.

$$\frac{5 - V_g}{10k} = 0 \quad \text{Q8's gate terminal as } V_g, \text{ loop from Q6's drain terminal to } V_g$$

$$\frac{13 - V_g}{1k} = 0 \quad \text{Loop from Q8's source terminal to } V_g \text{ through the Gate-Source Resistor.}$$

Solving for V_g , we find that in the worst case of the highest voltage being gated at Q8 of 13V, the voltage at the Gate with respect to Ground is 13.8V. By doing a KVL from the gate voltage to the source voltage of 13V, $(13.8V - 13V)$, the V_{gs} voltage sits at 800 mV well, which is well below the typical $V_{gs(th)}$ for the PMOS FET (FDB9503L-F085) of 1.8V. Figure below shows the redesign source selection system.

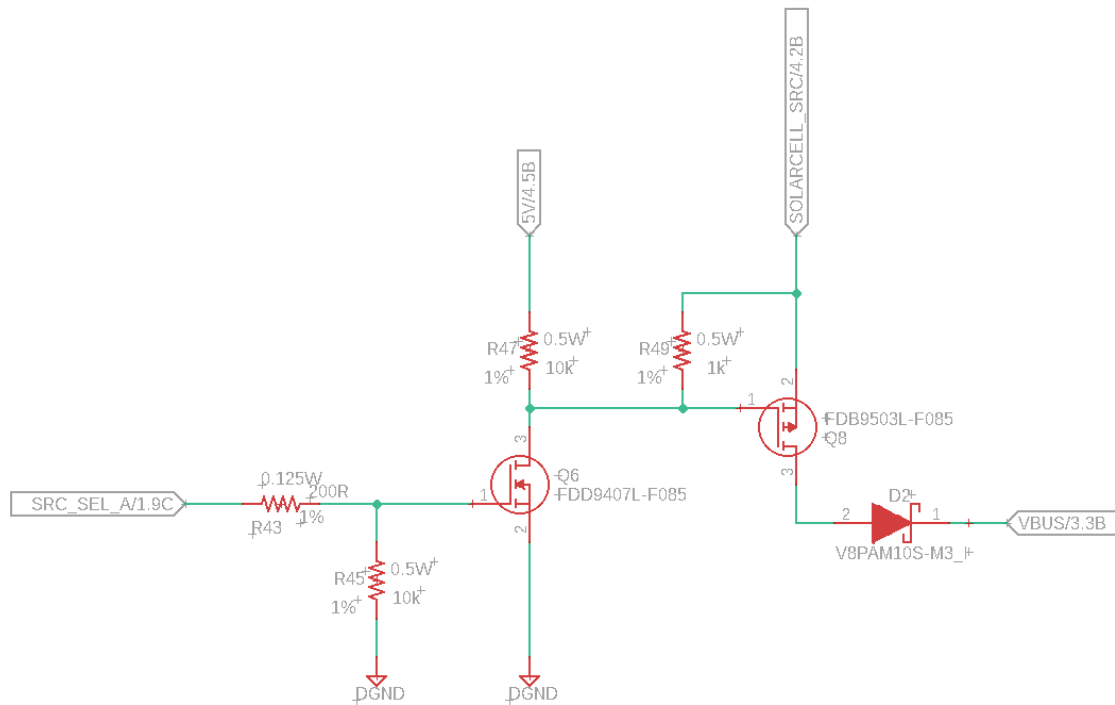

Figure 17: Modified Source Select Logic Circuit

Old Revision Component Selection - TLP3553A

The TLP3553A is a high current, medium voltage optocoupler from Toshiba, in our design it will directly serve as a switch for the incoming power source and output it to the Vsrc net which is the Power Rail connected to the Battery Bypass circuit discussed in the next paragraph. The table below from the TLP3553A datasheet depicts our main considerations in this component's selection.

Detector	OFF-state output terminal voltage	V_{OFF}	30	V
	ON-state current	I_{ON}	4	A
	ON-state current derating ($T_a \geq 25^\circ\text{C}$)	$\Delta I_{ON}/\Delta T_a$	-40	mA/°C
	ON-state current (pulsed) ($t = 100 \text{ ms}$, duty = 1/10)	I_{ONP}	9	A
	Output power dissipation	P_O	550	mW
	Output power dissipation derating ($T_a \geq 25^\circ\text{C}$)	$\Delta P_O/\Delta T_a$	-5.5	mW/°C
	Junction temperature	T_J	105	°C

Table 15: Optocoupler Datasheet Specifications

To state the most important parameter for this component's selection, the ON state current, meaning the forward current from collector to emitter whenever the LED is triggered, 4A gives the system ample leeway to supply enough current for its native internal functions as well as load demand.

In the worst calculated case of thermal breakdown, 70°C, the optocoupler is still able to supply enough current to charge the battery and the native on-system functions.

The second most important parameter, the **OFF-state output terminal voltage**, shows the maximum voltage allowed whenever the LED of the Optocoupler is not triggered, in our case is well below the expected 13V MAX from any of the available sources, only applicable to the case where more than one source is available.

STB160N75F3

This FET, originally selected to perform the duties of the Battery Bypass Circuit (Section 5.2.3) meets and exceeds the parameters needed in order to implement this circuit.

The purpose of this N-Channel FET is to gate the input from the Host MCU to control the optocoupler's LED input. To elaborate, the optocoupler's max forward current (I_f) is 30 mA and it is desirable to bias the LED close to the upper limit to ensure it gets triggered upon the receipt of the discrete signal from the MCU. With that in mind, the MCU (RP2040) max current per GPIO pin is 20 mA, not recommendable for this application given that it is recommended to stay a couple of mA under the limit.

Furthermore, the FET currently selected for the design has a $V_{gs(th)}$ range of about 2V - 4V and given that the MCU logic high level is 3.3V, there is a chance that the FET may not turn on. The selection of this FET will be furtherly reviewed in order to ensure enough voltage is supplied to meet the V_{gs} threshold parameter.

7.2 Battery Charging Circuit

For the system's battery charger IC, the part selected is LTC4162-L from Analog Components. The LTC IC features Li-Ion multicell battery charging and a control interface to transfer telemetry data to a microcontroller via the I2C communications protocol, the receiving MCU will be the host MCU, RP2040. Among the minimum input voltage is 4.5 V for single cell battery charging, assuming 4.2V per cell for Li-Ion batteries. For our design considerations a 3-cell Li-Ion battery will be considered as a starting point. Among the telemetry data available for reading, the battery charger IC will make available the battery voltage, battery current charge time, input voltage and many more including different fault flags. Also, according to the device's datasheet, some of the parameters for the battery charging profile are programmable over I2C communications.

By component selection, following the manufacturer's datasheet, the charging current will be based at 3A, corresponding to a 3000mAh battery capacity. Below is the design choice for the battery charging circuit.

Note the resistors R37 and R40 whose value is 0Ω, the purpose of these resistors is to have the option to use 2- or 3-Cell Li-Ion batteries without redoing the entire PCB design.

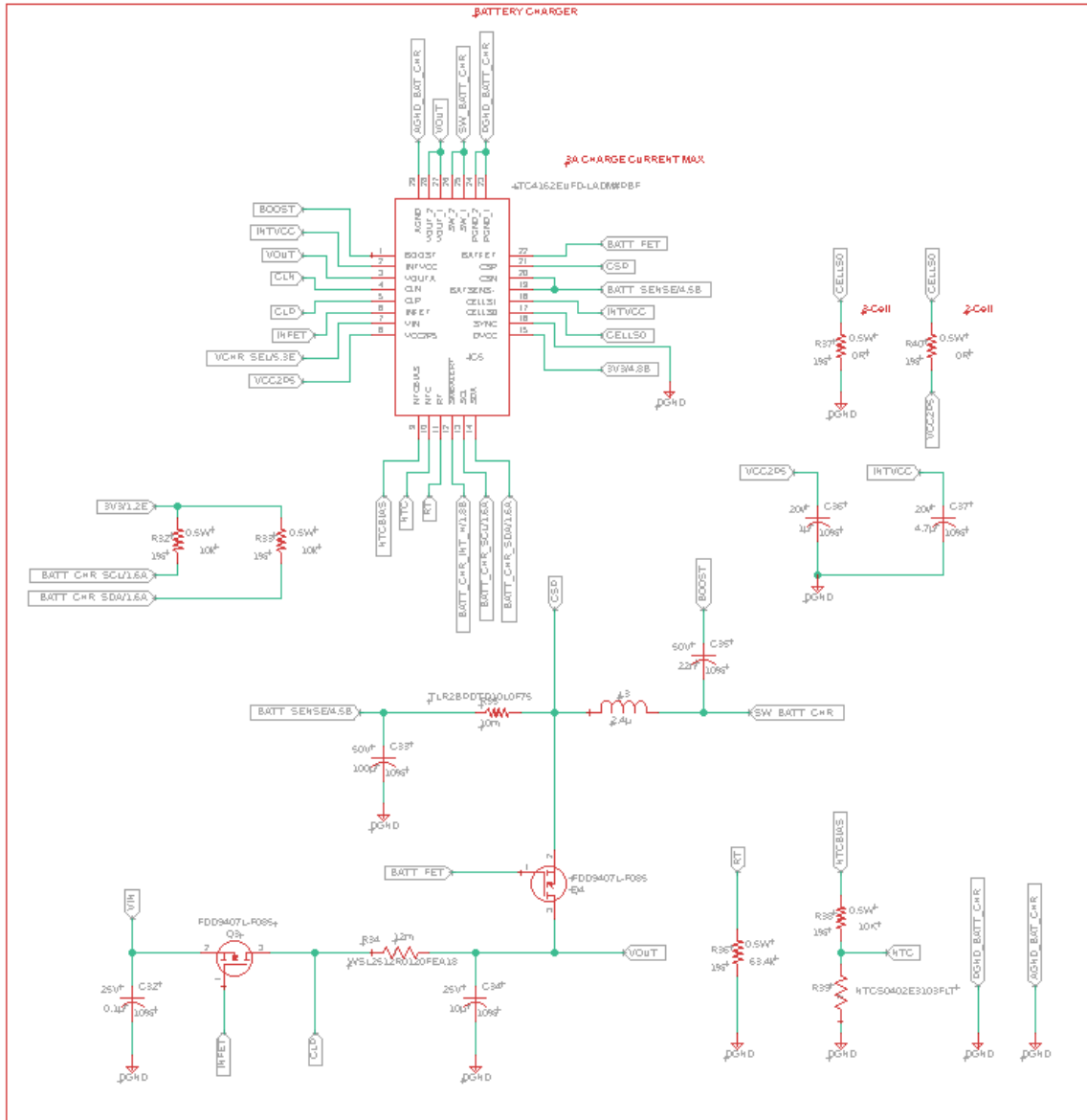

Figure 18: Battery Charger Circuit

On another note, adhering to the system design specification of full control over all inputs and outputs, the battery charger IC input voltage shall also be gated by the FET logic circuit depicted on the figure below. The input for this circuit shall also be software control and the Data line responsible for its output is “BATT_CHR_SEL”:

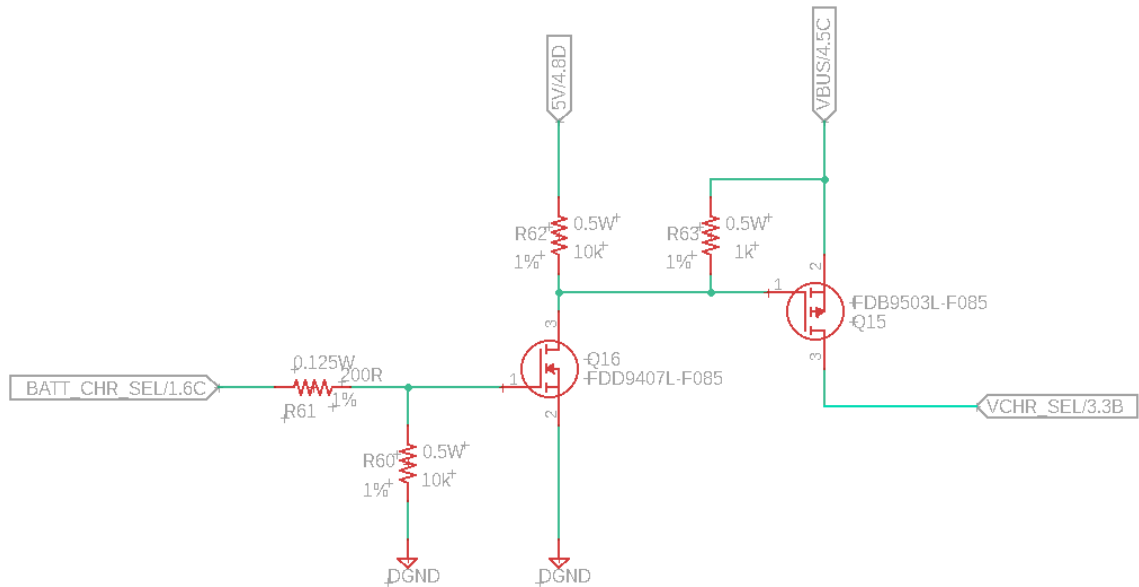

Figure 19: Battery Charger Enable Logic Circuit

7.3 Main Power Conditioning

Given the unpredictability of the incoming voltage from either the Hydro System, Solar System, Battery Power or the built in AC-DC converter, in order to provide stable input power to the DC DC converters responsible for the native functions of the system, i.e.: the Host MCU, Wireless Communications System and On System Sensors, the input power has to be conditioned to account for all possible scenarios of the source providing said power.

The following DC-DC converters accounts for the design consideration stated above and takes a wide range of input voltage (7V-13V) and steps it down to 5.2V and 3.3V for the general-purpose components power supply in our design.

7.3.1 5V Power Rail

The following DC DC converter circuit has the input range specified in section 5.2.2 (7V-13V) and has a nominal output centered at 5.2V to account for the load demand. Given that all of the sensors utilized in this design are powered by the 5V power rail, the load will be high, and the voltage is expected to be dragged down.

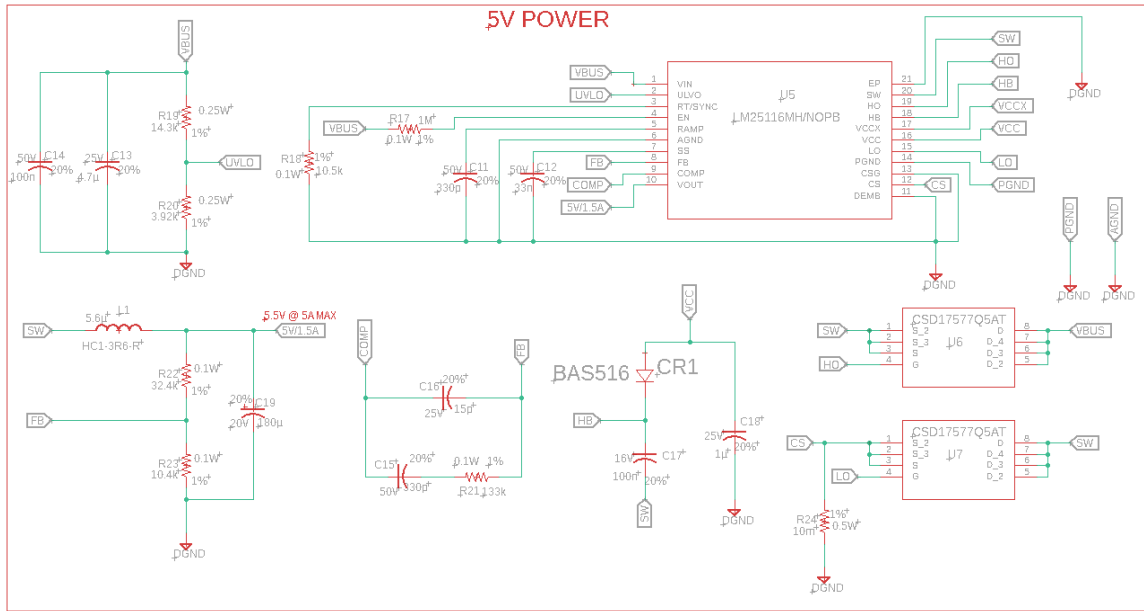

Figure 20:5V Power Rail DCDC Converter Circuit

The above figure depicts our ultra-high efficiency DC DC converter making use of the LM25116 Buck converter step down voltage regulator. The above configuration outputs 5.2V with a max power of 26W, well above the worst-case calculated power required to handle all the system components load demand. Efficiency is a key factor given the design constraints for our power system; in this case the above buck converter topology has an approximated efficiency of 97 % according to Webench Power Designer Tool.

7.3.2 3.3V Power Rail

Both MCU's in the system as well as some other discrete components require 3.3V power. Given how susceptible the system computers are to power fluctuations and unstable conditions, efficiency as well as a noise free MCU low power source is worth having in our system. For this power rail the component selection is the TPS62913.

The **TPS40303** Voltage Regulator is a low noise, low ripple with a Buck converter topology. The design of choice for the 3.3V power rail is estimated to be about 95 % efficient. Moreover, in order to maximize noise cancellation, a two-stage filter featuring a ferrite bead choke on its second stage (see L3 on the figure below). Noise is halved by implementing this filter to about 10µV RMS assuming no external factors.

As far as the 3.3V transfer and absolute maximum characteristics, it will nominally output 3.3V @ 2 A max for a max of 6.6 W. It also accepts a wide range of inputs (4.9V - 13V) to account for the unpredictability of the source availability. The figure below depicts the DC DC converter with the 3.3V output whose output net is named 3V3A to differentiate it from the 3.3V net from the USB interfaces, both gated by a bypass FET circuit.

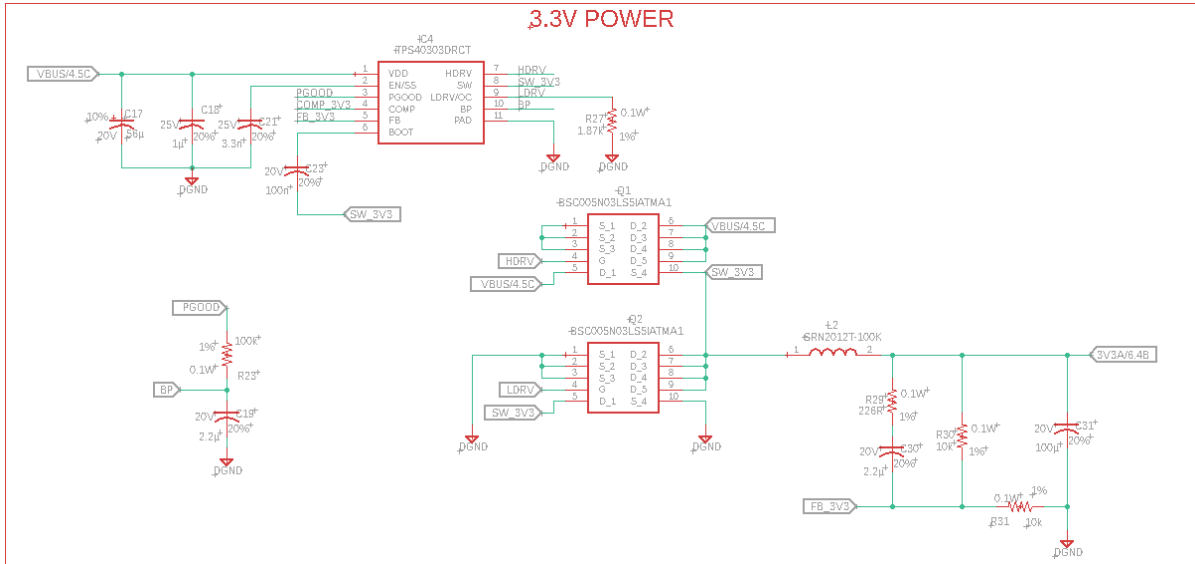

Figure 21:5V Power Rail DCDC Converter Circuit

7.3.3 AC to DC Power Conditioning

In addition to the solar cell and the on-system battery pack, the system will also count with an AC to DC converter implementation. This functionality is used with the intention of providing a solution for whenever the consumer or user of this product finds himself at a place or location where power or energy is inexpensive or the system battery is completely dead and a battery replenishment is required as a priority, after a certain battery voltage under-threshold the system shall display an alert to the user indicating that battery replenishment is needed. The figure below shows the figure depicting the AC to DC topology used.

Parts Selection

BR1010

The BR1010 full bridge rectifier is a single SMD package featuring low forward voltage drop and a max forward current RMS of 10 A (per element).

F-252U

The transformer selected has an input voltage of 115 VAC RMS and output voltage of 14 VAC RMS with a max output current on the secondary winding of 4A.

The capacitors selected are 4 Electrolytic Aluminum capacitor of 2200µF to mitigate the ripple voltage effects on the output of the rectifier. With this capacitance the expected and simulated ripple is in the order of < 50mV. In order to filter the noise some more as well as providing an stable DC waveform an additional DC DC converter is used to step down the voltage to about 12.7V, which is right below the designed Vmax input for the DCDC converters.

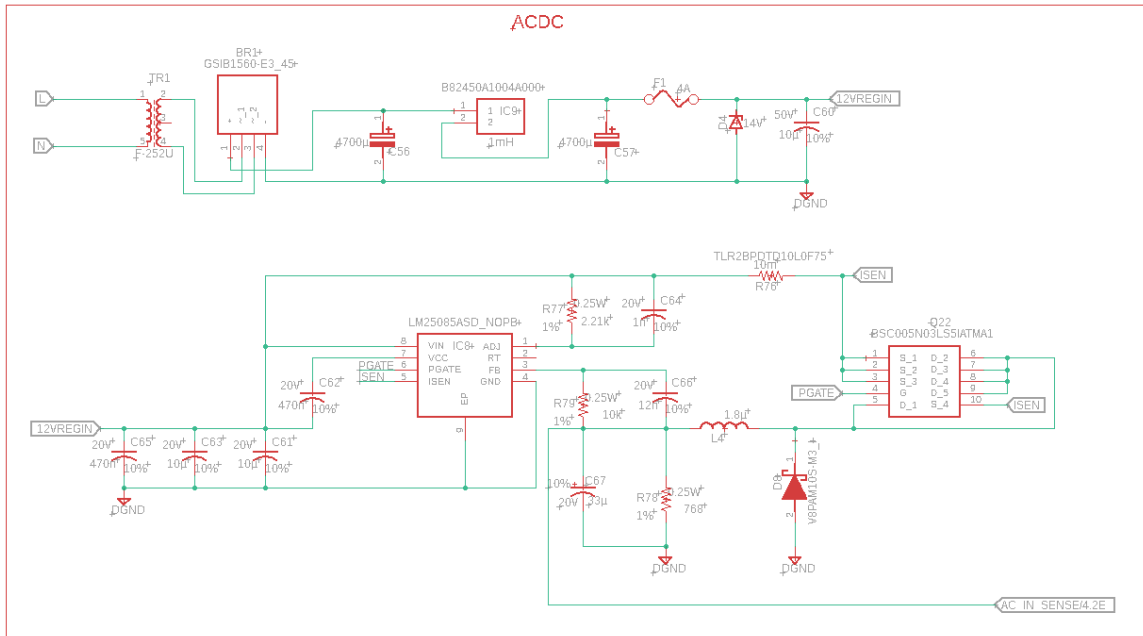

Figure 22:ACDC Circuit with 12V Regulated Output

The low side of the circuit after full wave rectification as well as step down to about 13V-14V also counts with a fuse, slow blow rated for 4A max. The reason for this additional DCDC converter is to attempt to smoothen out and stabilize the DC signal before it reaches to VBUS where it will feed all of the major components.

The IC selected for this circuit is the Texas Instruments' **LM25085A** counting with a wide range input of 4.5V - 42V.

This design is inspired by the referenced design given in the IC's datasheet.

7.4 Rx/Tx Data Flow Indicators

The main and only purpose for the inter board communication implementation between the Host MCU (RP2040) and the wireless communication module (ESP32) is merely just the transmission and receipt of commands and data to and from the base server database. In other words, the only reason for any sort of activity on the UART bus between the Host MCU and the wireless communications module is to transfer data to and from the server database and nothing else.

To do that we have implemented a circuit that gets triggered whenever there is activity on the data line. One circuit implementation for each one of the UART lines Rx and Tx.

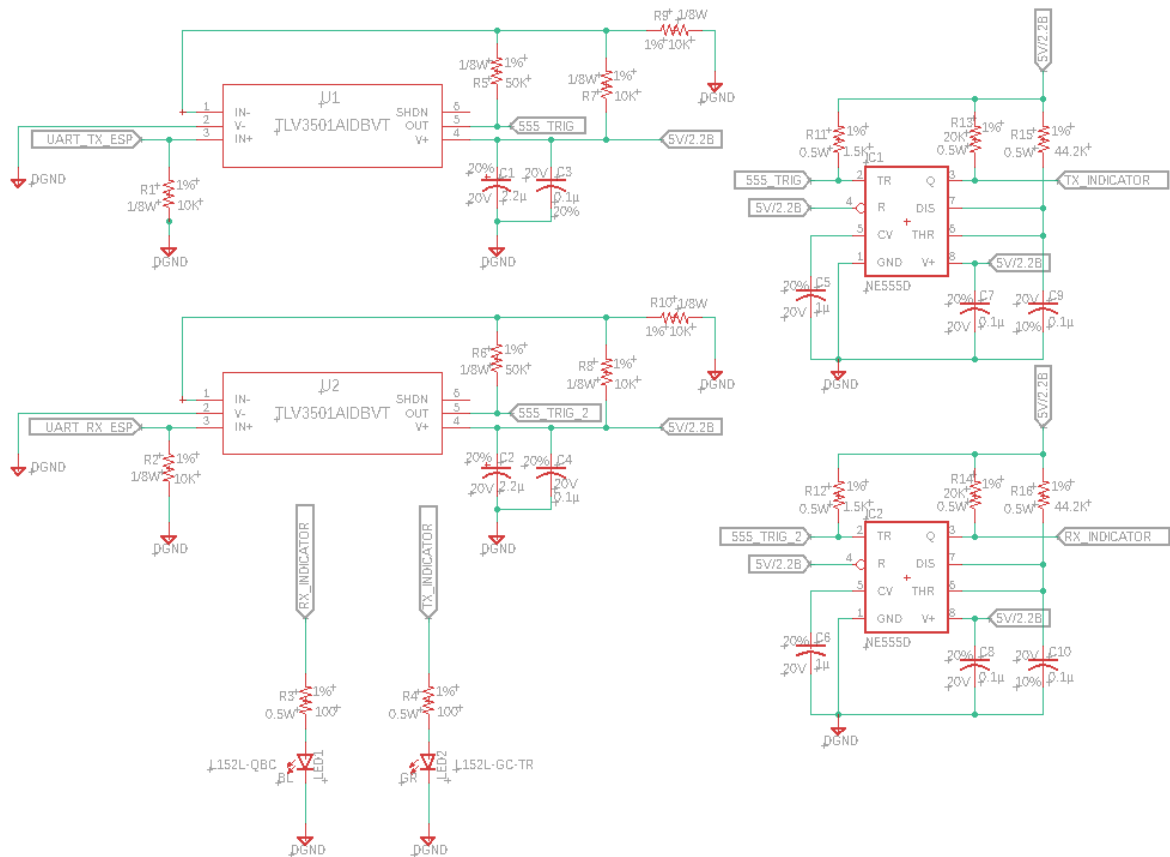

Figure 23: Network Tx/Rx Data Flow Indicator Circuit

Taking the above statements regarding the system's inter board communication and wireless connectivity into consideration, the sole purpose of the schematic capture depicted on the figure above is a pulse stretching circuit for the UART lines (Rx & Tx) between the Host MCU and wireless communication module. Given that the UART bus will be basing its messages at a rate of 115200 baud (115.2 KHz), the pulses on the UART lines are simply way too quick in order to directly connect LED indicators on them. Aside from the transmission speed is also the noise and impedance matching design considerations. By choosing the following components these requirements are satisfied:

TLV3501 Comparator

This is a high-speed comparator with a very low turn on time, 100 ns, and high input impedance, two of the most crucial factors for this application. Because of the comparators high input impedance characteristics (10^{13} ohms) and the resistor selector on the input side (10 k Ω) of the comparator the highest recorded current drawn from the UART lines was in the order of <200 μ A, making it almost invisible to the UART lines and triggering its output (active low) practically immediately after every bit of UART transmission, setting the conditions for the NE555 timer to condition the signal for the LED's activation. The In- pin is biased with a reference voltage of about 2.5V to ensure the comparator is triggered before the UART line reaches the 0V potential. This circuit is featured on both the Rx line and Tx line of the UART bus.

NE555 Timer

In this case the NE555 timer is used on its Monostable “One Shot” Retriggerable “Pulse Stretcher” configuration, obeying the equation: $\tau = 1.1 \cdot R \cdot C$ where Tau is the period of the pulse generated after every trigger R and C represent the Resistor and Capacitor connected in parallel to the Threshold and Discharge pins (Pins 6 & 7 respectively). By selecting Resistor and Capacitor values of 44.2k Ω and 1 μ F respectively we achieve a time pulse duration of 44.2 ms, which might end up drifting to 45 ms because of component tolerances. This pulse period is more than enough for the human eye to visualize activity on these LED’s. The design features one timer per UART line.

On the Figure below some simulation data shows the expected waveform for the pulse stretching circuit. Where the light blue waveform represents the trigger from the UART line and the dark blue wave form represents the waveform generated by the 555 timer.

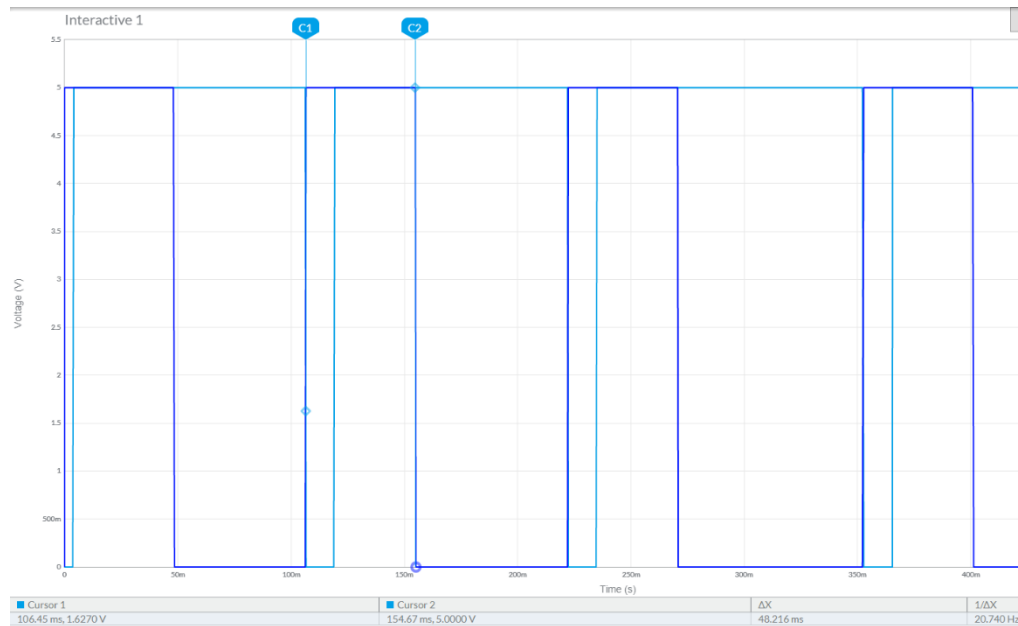

Figure 24: Pulse Stretching Signal Simulation Waveform

7.5 Other Sensors Implementation

Temperature Sensor

As discussed on the sensors section, the selected temperature sensor is the DS18B20, this temperature sensor utilizes the 1-wire bus protocol to interface with the Host MCU. In addition to that, the sensor will not be located on the PCB and will be remotely placed at the section of the system where the highest temperature is expected. The figure below depicts the connector used to interface the sensor with our system.

Flow Rate Sensor

In order to extrapolate the data in regards to the amount of power inputted to the pump with respect to the amount of power outputted by the turbine, the flow rate sensor will serve as a direct relational indicator between the amount of water that flows and the power produced, it may even serve as a tester for trying different combinations of turbines and water in order to maximize efficiency. The flow rate sensor is comprised of a Hall effect

sensor in order to count the RPM's performed by a given stream. It uses a similar protocol as the 1-Wire Bus and it is interfaced to the RP20410 via a single wire. The figure below shows the screw terminal used to interface this sensor with the system.

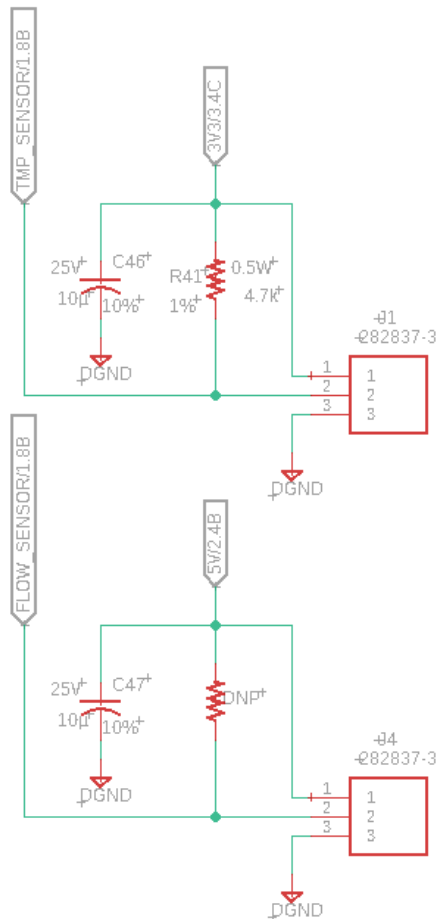

Figure 25: Temperature Sensor and Flow Sensor Peripherals Interface

Light Sensor

The selected light sensor selected as described in the light sensor section is the LTR-553ALS-01 manufactured by ams. This sensor offers I2C and SMBus interfacing. In our case the sensor will be tied to the I2C Bus 2 data bus sharing the bus with the battery charger IC. Design considerations requiring to have the light sensor exposed to detect light so the Solar Panel source can be used calls for a separate PCB with the sensor on it so it can be placed outside of the inner components section.

7.6 Source to Load Selection

As show on the system high level diagram in the beginning of this chapter, the system features controllability of enabling or disabling an applied load to the system, this function is also software controlled by the data lines HYDRO_LOAD_SEL & VBUS_LOAD_CEL.

The need for this circuit implementation comes from the impossibility to directly feed the power outputted by the Hydro generator back into Vbus, given that Vbus is already serving as the power source to the pump. Hence, there is already a voltage source present on Vbus at that given moment. Therefore, in the event that the Hydro source selection is active, the user can only opt to output this power source back into the “grid” or to an external source. Vbus is, by default, always supplying all of the internal and external load demands. The mentioned circuits, utilize the same of topology from the Source Select Revision, Section 6.2.1.3.1

In addition to this feature, in the event where Vbus and Vhydro are both available, the user has the ability to select which source performs the duties of supplying the external load demand present, the latest condition is true and will be accomplished if and only if Vhydro is larger than Vbus or is above a hard coded or user defined threshold. Unfortunately, this is one of the cases in which the unpredictability of the voltage levels for the signals in question does not permit for a discrete-only implementation and it must be software controlled in order to switch over from power source to power source to supply the load demand. The circuit depicted on the figure below permits to gate the Hydro source after the pump has already been turned on through the data line “SRC_SEL_C” in order to optimize the power consumption vs inputted power ratio through the Electronic Speed Controller PWM and the power sensor for both the pump and the generator. And, if the desired power optimization is achieved or if the user decides it then the voltage source for the load may be switched over to the Hydro generator through the data line “HYDRO_LOAD_SEL.”

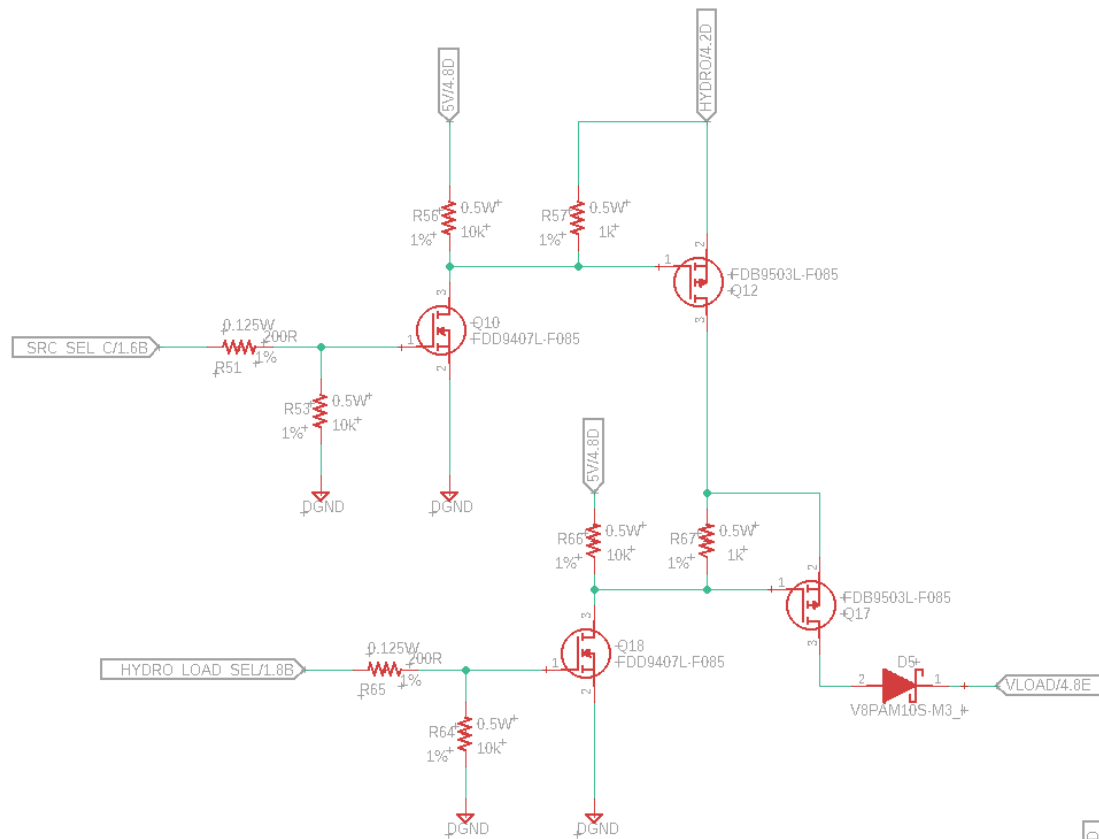

Figure 26:Hydro Generated Power & External Load Select / Enable Logic Circuit

As explained above, only one of the power sources may feed the external load demand at any given time and the output may behave in a XOR fashion. This feature shall be software controlled to ensure that the data lines HYDRO_LOAD_SEL & VBUS_LOAD_SEL may act interchangeable and the high state of one of them disables the other one. The figure below depicts the circuit utilized to gate and select the VBUS signal as the source for the external load demand. A similar circuit is implemented to gate the Hydro voltage source from the external load output.

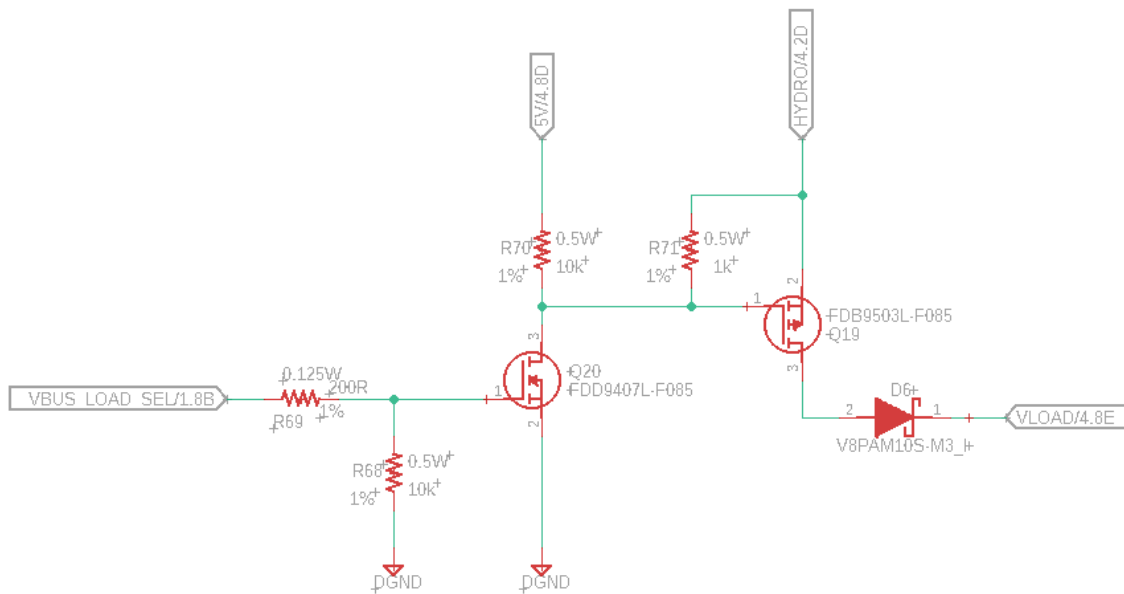

Figure 27: VBUS Rail External Load Enable Logic Circuit

7.7 In-System Programmability

In order to fully develop, employ, debug and exploit all of the features that this system possesses, a high-level implementation of software development interfacing is required for both, the Host MCU (RP2040) and the Wireless Communications Module (ESP32).

Luckily, the RP2040 IC possesses a USB to TTL converter integrated in its package, where the only connections necessary are the D+ and D- standard USB connections directly to the IC with termination resistors for impedance matching in order to meet the USB Standard. On the other hand, the ESP32 does not count with an integrated USB to TTL like the RP2040 does.

While there are several external solutions in place to serve as Flash Emulation Tools for the ESP32 such as universal USB to UART bridges, there are features that are lost such as the bootloader mode, used to flash low level firmware into the board and change interpreters, required to initially burn the Micropython interpreter into both IC's. This is why we have implemented the Micro USB connectors for both, the RP2040 and ESP32 IC's.

As far as the power goes for the USB connector to the on board MCU's we have used the following solution in order to keep the same logic level and differential when debugging using USB's. The figure below contains the USB connectors used as well as the logic used to handle the power.

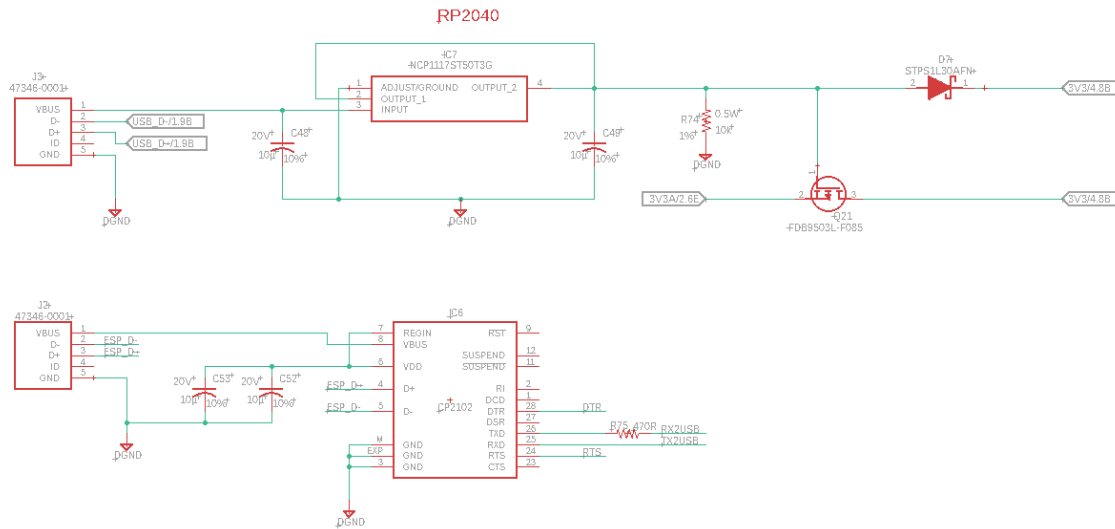

Figure 28: In system Programmability MicroUSB Interfaces

The figure above shows a dedicated Voltage Regulator just employed through USB power whenever development operations are ongoing. This circuit ensures that there does not necessarily have to be a source applied power to the system in order to debug any of the on board MCU's. In fact, it is required to have the same Ground connection for the UART to USB and vice versa conversion to occur properly, the regulator selected for this task is the NCP1117 with a fixed output of 3.3V when supplied with 4.5V - 5.2V will be supplied with 5V from a host computer whenever the RP2040 connector is plugged in. The FET circuit connected to the output is a bypass FET circuit that will gate the 3V3A net outputted from the on board 3.3V regulator supplied by VBUS by whatever source is available at any given moment. The PMOS FET is a logic level transistor whose $V_{gs(th)}$ max voltage is $-3V$ therefore the activation / deactivation of the functions on this circuit is guaranteed every time the USB connector is connected or disconnected

This feature is especially useful to be able to run the firmware and interact with the hardware using software development tools at runtime without interrupting the physical interfaces of the system. Whenever power is removed from gate of the FET, hence the USB is removed, the FET's gate will be driven to 0V (GND) through the 10k pulldown gate resistor, therefore V_{gs} will be at $-3.3V$ allowing 3V3A to pass through the FET from source to drain.

As described on the opening paragraph for this section, the RP2040 MCU does not require a USB to UART converter and the ESP32 does. The figure above shows both USB interfaces for the RP2040 and the ESP32, where J3 is the MicroUSB connector for the RP2040 MCU and J2 is the MicroUSB for the ESP32. With that being said, the USB interfaces also feature a function where the USB power is provided solely by the RP2040 MicroUSB connector, and while the USB is plugged it supplies the entire 3V3 net for our system, which by analysis does not cause a load greater than 200 mA, well below the 500 mA limit supplied by standard computers USB connector, even though the NCP1117 DC-DC converter can output up to 1A of current.

This feature was done on purpose given that the RP2040 is the Host MCU and any changes to the Wireless Communications Module software will indeed cause a change in the

expected inputs and outputs as far as the RP2040. In other words, whenever debugging is required on the ESP32, as a consequence the RP2040 will likely require a change, besides this solutions saves on BOM costs and footprint area.

7.8 LCD Display

To interface with the selected LCD Display pixxi-LCD-13P2, which houses its own driver and MCU to optimize GUI designs will communicate with Host MCU via UART and it will be on the channel 1 of UART on GPIO pins 8 and 9.

7.9 Pump PWM Control

A common misconception regarding turbines, angular speed and its relationship to outputted power is that the fastest you can rotate a generator's shaft, the more power it can potentially produce or output. However, this is not always the case. Depending on the load and its characteristics it may be worthwhile to produce a more stable current source than higher voltage levels. This is exactly the case with increasing the rotational speed of a generator's shaft, the faster it rotates the more voltage it will produce. But, the moment the load demand increases over a certain point it will inherently slow down the shaft and create more friction against its movement.

This is exactly the point of implementing an Electronic Speed Controller (ESC) to find the Maximum Power Point Tracking which is the "sweet spot" where the current is not at its maximum however the voltage is at its maximum expression. A graphical representation is shown on the figure below:

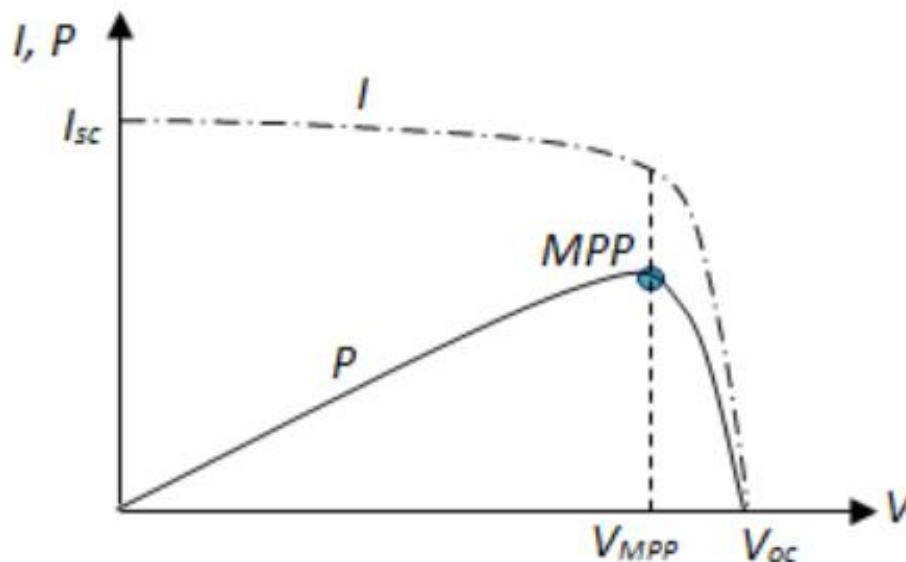

Figure 29: Maximum Power Point Tracking Representation

Without any more preamble, the system will employ a simple ESC implementation using a logic level NMOS FET previously used on other discrete input circuits on our system.

In this case the ESC will be inputted a PWM signal originated from the Host MCU:

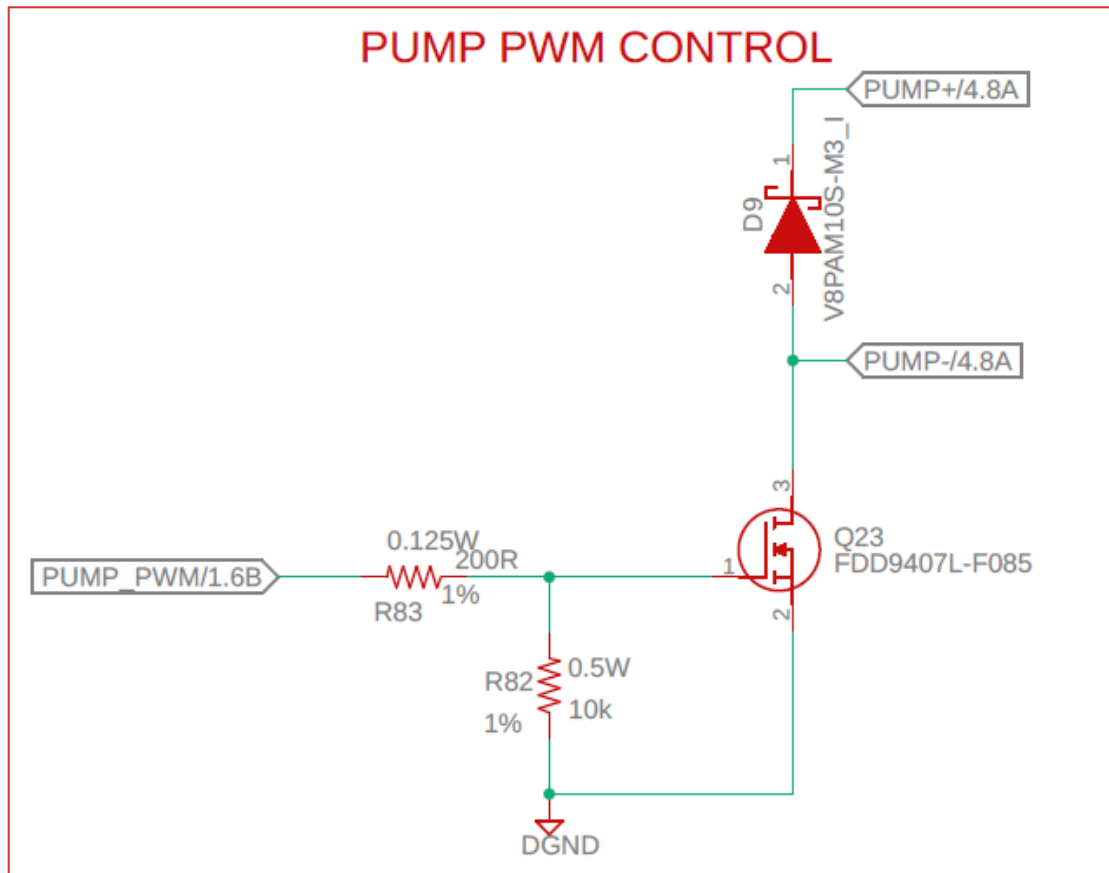

Figure 30: Pump PWM Electronic Speed Controller

This approach is valid since the pump being used is a brushed DC motor and it will move only in one direction, so an H-Bridge is not required.

After all was said and done, our initial PCB design ended up being too complex and expensive to print on to one single surface mount board. We did send the board out to print, but the company we chose simply did not do a good job and our boards were ruined on one of the connections because of them. Because of this, we ended up splitting the controls and power sections of our PCB into two separate boards, which can be seen on our website in our files sections.

The power controller board handled the 3.3V and 5V distribution throughout the system, as well as handling the power transformation both upwards and downwards coming in and out of our system, while the controls board handled accumulating all the data from our sensors and being able to converse with our website and data pulling sources. This allowed us to print two PCBs instead of one, which made the board much less complex and easier to print.

8.0 Software Architecture

With any design process, developing the software is a crucial process. As technology improves the use of software becomes more relevant to the equation. During the early times of engineering, mechanical devices would be used. This would take up massive amounts of space. Fast forwarding to today, software can replace large banks of relays and other type of control devices. Making the process both easier and more complicated. Therefore, developing a software to match the design is important and is considered the brain of any device. In this section, we have described the software, or code, that was created for this system.

8.1 Data Sources

Before explaining what the capabilities of the software architecture of the microcontroller will be, it is important to notate what data sources will be implemented into the design so that all variables are identified. The microcontroller will serve as the central computational element that will take in values from each data source and control the system accordingly. After collection is complete, the data will be sent to the proper location for analysis and will determine if further calculations need to be performed. Without any data analysis, the software will not be able to use any data it receives. Therefore, it will become wasted space in the system memory.

8.1.1 Sensor Data

There are four different data sources that will be taken from individual sensors. The first is the temperature sensor. The role of the temperature sensor is to measure the temperature of the system, ensuring that the system can operate without experiencing temperatures that would be harmful to any of the components. The second sensor will be the light sensor, the purpose of which was discussed previously as a reference to determine if it is effective for the system to engage the solar panels at a given time. The third is the flow rate sensor, which will measure the flow rate of the water pump to determine if that part of the system is operating effectively and will provide information regarding whether sufficient power is being drawn from that part of the system.

To understand how much power is being provided to the system by the two power sources, as well as the ratio of how much power is being provided by each source, data from the fourth type of sensor, the power reading sensors will be monitored. These sensors will serve as a hub where the power readings of both the solar panels and the micro hydroelectric system will converge. These sensors will provide information used in calculating the overall efficiency of the system as a power generator and the ratio between power used to operate the system versus power being delivered to the load.

8.1.2 FET Logic Circuits

As a safety feature of the system, data from the various FET logic circuits will be considered to monitor the power generation sources of the system. In cases where power generation from either the solar panels or micro hydroelectric system are not stable, the microcontroller will be able to send a signal to the appropriate relay to isolate either source

from the rest of the system. This capability will help prevent the rest of the system from being destroyed in cases where either power generation is not stable or in cases where power is not being distributed correctly.

8.1.3 Output Data

Output data can come in two different forms. First being the output of the source, which would be the input of the system. It is important to know the output of the source data. This tells us if the power sources are working at the levels they are intended to be. Without this data we would be unable to determine where any problems can originate from, or if the system is unable to keep up with the demand of the load. The source output data will be key information in determining other points of interest.

Second form of output data is from the load. Without this data, the system will be unknown to if it is working or not. Using this data will show the efficiency of the system. It will also be ever changing. Because total load power is constantly changing from the use by the consumer. The efficiency will also be changing. Over time we have be able to graph the uses and find an average load. This data is what will determine the values our system is looking for.

For the purposes of monitoring the system and observing its efficiency, output data will also be recorded and given a role. The output data being recorded will be the load of the system, providing necessary values to calculate the efficiency of the system by comparing the load value with the total power generation value.

8.2 Data Display & Records

The other side of data regulation will be for the display and recording of system information. The purpose of this is to monitor the system for either operational abnormalities or system evaluation to improve the system further. There will be two methodologies to monitor system information. The first will be the LCD screen implemented onto the physical system and the other will be a remotely operated server-based information display.

8.2.1 LCD Information Display

The first method of displaying information is the use of an LCD display. This type of display is used in all standard forms of systems. It is one of the longest used kinds and has been labeled as one of the most reliable. An LCD display gives on the spot information of a system but isn't able to store the data. LCD's run at a thirty fame per second rating. Majority of them have a one-color scheme. Displaying in either red, green, or blue. Newer ones have used a blue screen. This is easier to read in a low light situation. This is acceptable because there isn't the need for a high resolution. It gives the user a quick look into how the system is working. All the data is collected by the software and is sent to the LCD. This data is always up to date. Otherwise, known as a snapshot of the system. The LCD display can be used to make sure the software is correctly reading the data from the system. By matching all field readings to the outputs on the screen.

8.2.2 Server Based information Display

One of the new forms to display information, is uploading data to a server. From here a user can log into the server and retrieve the data at any given time. As the system constantly updates the server, a user can see all updated information. One benefit of this type of display is that the data can be stored on the server. This would give us a full range of data to analysis. From here we can tell when the system is working at its full efficiency or give insight to potential areas that need improvement. A server-based display does have its disadvantage. That disadvantage is in the security of the data. Because the system data will be stored on a server, it is prone to hacking. There are defensive measures in place, on these servers, to prevent this from happening.

However, hacking still does happen. For the personal energy data, might not be considered a high priority for a hacker to investigate. If the server was shared with a larger company, then the user's personal data could also be accessed. Even with the threat of hacking, this type of display is still being used more and more. That is because of the ease of collecting the data and the showing of a system over time. This is why we choose to use a server-based display. Being able to look back at previous data and seeing live data, was the biggest factor in this decision.

8.3 Software Capabilities with Pseudocode

The capability of a software is at the limitation of the designer. Over the years software has been changing the way we develop systems and machinery. It has paved the way for each engineering team to improve upon the previous system and change original ways of thinking. With each change, a new form of the software is created. One method of being able to decipher another engineer's code, is with the use of pseudocode. In this section we have look at the system code and functions needed to perform the tasks.

Each of the functions displayed below are subject to change as the development of the system progresses. It is expected that cases will arise that will challenge and perhaps make it necessary to reevaluate the methodology which libraries and hardware components are initialized, called, written to, etc. Until the construction and operation of the system is deemed complete, the following sections will discuss the overarching software flow of the system and the capabilities of each individual function.

Due to changes in the system software architecture, the project was changed to be operated manually via remote server as opposed to being operated automatically. Due to this change, all functions relevant to sections 8.3.1 to 8.3.6 are no longer part of the software components of the system aside from unused pseudocode. Sections 8.3.7 onward are still implemented into the final design as the software components responsible for communication between the remote server and the system are critical to the final system design.

8.3.1 Main Function

Once the necessary component of the software is to import all the necessary libraries that are needed to perform all other functions that use readings or values from anything other than the basic libraries such as time and requests. Provided in the pseudocode below are the hardware components that will require corresponding libraries to be imported to both

draw data from and if necessary, control each hardware component. Beneath the import commands is the main function of the code. The approach to the code is to develop several functions that perform different roles for the system. Each of these functions will be discussed individually so that their context within the main function is realized.

It is important to note that each projected component that would need to be interfaced with the microcontroller would also need their respective libraries added to the boot code of the microcontroller. While this is not represented in the pseudocode below, it is necessary to mention that the capability to register each hardware component with the microcontroller is enabled by manually downloading said capabilities onto the board. This way when the code is imported onto the microcontroller, the libraries being imported are available and can be used to interface with each device. This is why it was important to choose sensor components that were known to be compatible with the RP2040.

```
import Lightsensor
import Tempsensor
import Flowratesensor
import Battery
import Powersensor1
import Powersensor2
import Loadvalue
import Relays
import LCD
import time
import requests

def main_function:

    readsensors_function()
    engagepower_function()
    powermonitor_function()
    displayLCD_function()
    serverupdatepost_function()
    serverupdateget_function()
```

8.3.2 Read Sensors Function

The read sensor's function is meant to declare each variable that will be monitored and updated in accordance with the software requirements of the project and used in other functions. Given that each variable will be used in other functions, each of the variables is given a global status so that they may be referenced accordingly with up-to-date values. Because this is system that is meant to be run over a period of time. Using read sensors to obtain data, at any given minute, is vital to the stability of the system. These sensors are meant to respond to any data that appears to be out of normal values. They will simply be

the eyes and ears of the system and repost all data to the display server for further evaluation by the user or engineer.

```
def readsensors_function:
    while True:
        global Light = sensor.light
        global Temp = sensor.temp
        global Flow = sensor.flow
        global Batt = sensor.batterycapacity
        global Pow1 = sensor.power1
        global Pow2 = sensor.power2
        global Load = sensor.Loadvalue
```

8.3.3 Engage Power Function

This function will be used to determine when a power system is engaged based on appropriate sensor readings. The light sensor will be used to determine the viability of using the solar panels to generate power and the flow rate sensor will be used similarly for the hydro electric generator. A variable “x” is used in place of an arbitrary number that will be modified as the system is tested and optimized. Accordingly, when the light sensor reads a value above a certain value, the system will determine that it would be efficient and effective to engage the solar panels and begin to draw power from it. Likewise, when the flow rate of water read by the flow rate sensor achieves a certain value, the system will engage the hydroelectric generator and draw power from that generator. Additional global variables “Sol” and “Hyd” are declared and set to a value of 1 in each case to signify that either power source is being engaged.

```
def engagepower_function:
    while (Light >= x):
        {engage solar panels}
        global Sol = 1
        goto relay_function
    while (Flow >= x):
        {engage hydro generator}
        global Hyd = 1
        goto relay_function
```

8.3.4 Relay Function

A function for both relays is provided for the purpose of safely disengaging either or both of the power generators. Variables signifying the stability of the power generation for each generator are declared. If statements are made to signify that when power fluctuations

occur too commonly, each of the generators can be disengaged accordingly. A third if statement condition is also declared, saying that if the temperature of the system goes over a declared value, that both generators will be disengaged. Consequently, when either generator is disengaged, the global variables “Sol” and “Hyd”, signifying if the generator is operating is set to 0.

```
def relay_function:
    while True:
        if (solarpowerstability > x):
            {disengage solar panels via relay}
            Sol = 0
        if (hydropowerstability > x):
            {disengage hydro generator via relay}
            Hyd = 0
        if (Temp > x):
            {disengage solar panels via relay}
            {disengage hydro generator via relay}
            Sol = 0
            Hyd = 0
```

8.3.5 Power Monitor Function

The power monitor function is a simple function meant to calculate the total power output between the two generators and subsequently the efficiency of the system by comparing the total power output of the system with the load being applied to the system. The variable for efficiency is declared as a global variable so that it can be referenced in display and server update functions. Although, we are not concerned with the total efficiency of this design. It is still important to see how well the system is working. As new technology is developed, and with the addition of this technology, the efficiency could improve as well. Because we can monitor it, then we can see how new devices can either improve or degrade the current system. Many power systems strive to have a high efficiency level, and upgrades are constantly being developed to achieve this goal.

```
def powermonitor_function:
    while True:
        Powertotal = Pow1 + Pow2
        global Efficiency = Powertotal / Load
```

8.3.6 LCD Display Function

This LCD display function is meant to show how updated values for both generation sources will be displayed on the LCD screen. The first bit of data that will be displayed is whether the system is on or off. This is simple high/low signal from the microcontroller. We added this function to the display because we wanted to know which source the system was receiving the power from. Knowing this information would allow the user to

troubleshoot any low input power from the sources. Because time is always a factor in any troubleshooting techniques, being able to see from the screen which source is being used help in formulating a solution. The next bit of data to be displayed is the source output. We want to be able to see the voltage and current output from either the solar or hydro. From here we have to be able to display the power output from either of them. Next, bit of data to be displayed is the output from the load. Again, reading the current being drawn and the total voltage. With this knowledge we have to be able to find the power consumed by the load. Last, bit of data we want to display is the efficiency of the system. All data collected will be constantly changing as the circumstances of the load system change.

Depending on the size of the screen and the font of the LCD, some of the data will need to be sent to another form of display. The more important output data would be the power of the sources and the power consumption of the load. This will give us a reference point to check the efficiency of the system. Just in case we need to check if the software is running correctly.

```
def displayLCD_function:
    while True:
        lcd_line_1 = "Solar Sys = ", Sol
        lcd_line_2 = "Hydro Sys = ", Hyd
        lcd_line_3 = "Solar Gen = ", Pow1, " W"
        lcd_line_4 = "Hydro Gen = ", Pow2, " W"
        lcd_line_5 = "Load = ", Load
        lcd_line_6 = "Efficiency = ", Efficiency
```

8.3.7 Server Communications

The server update function displayed below is a placeholder indicating how system data will be submitted to and requested from the remote server. As per the system requirements, system data will be posted to the server in intervals of 5 seconds and will request to get data from the server every 2 seconds.

```
def serverupdatepost_function:
    while True:
        requests.post to server
        time.sleep(5)
def serverupdateget_function:
    while True:
        requests.get to server
        time.sleep(2)
```

The main concept being followed with this design approach is the implementation of an IoT (Internet of Things) like device. However, in this case we followed a more traditional approach to build the network infrastructure. Instead of using built in APIs such as NodeRed or Adafruit's built in IoT API, we used the traditional HTTP requests approach to gather data from and to the server by the MCU.

This process was done by implementing a LAMP-like server architecture (Linux, Apache, MySQL, Python/Perl) running on a Raspberry Pi 4 with Raspberry Pi OS (formerly called Raspbian). The Wireless Communication Module shall make a POST request to the back-end server every 5 seconds providing live data regarding the system status, load demand, battery life, and external sources status. This data will be stored in a MySQL database for easier management sorting and easy access to the front end interface.

In addition to making this post request with this interval, the Wireless Communication module shall also make a GET request every 3 seconds accessing the configuration files amended by the user on the front end anytime a command is given such as turn on/ off a certain part of the system. All data transfers are done in JSON format and unpacked by the receiving end.

This functionality has already been proven and is depicted in the following figures:

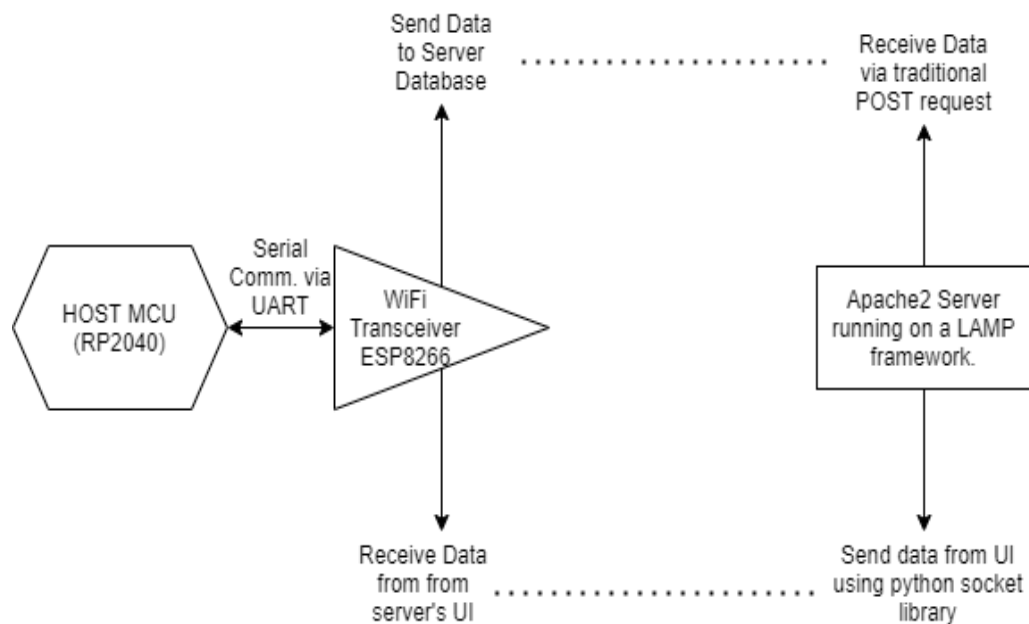

Figure 31:LAMP Server & Data Flow Architecture

Figure 31 above, shows the process structure in order to accomplish the expected behavior stated above.

This functionality of the system has already been tested and is depicted in the figure below. The figure shows the access log from the server showing POST requests from the Wireless Communications Module every 4 seconds.

Figure 28 shows the backend interface for the MySQL database, PhpMyAdmin, which is a management system for SQL databases running on an Apache server integrated with PHP.

```

pi@raspberr... x | pi@raspberr... x | pi@raspberr... x | *pi@raspberr... x | pi@raspberr... x
192.168.0.154 - [25/Oct/2021:00:09:13 -0400] "POST /test/sendtosocket.php HTTP/1.1" 200 251 "-" "python-requests/2.26.0"
192.168.0.144 - [25/Oct/2021:00:10:01 -0400] "POST /test/data.php HTTP/1.0" 200 175 "-" "-"
192.168.0.154 - [25/Oct/2021:00:10:01 -0400] "POST /test/sendtosocket.php HTTP/1.1" 200 251 "-" "python-requests/2.26.0"
192.168.0.144 - [25/Oct/2021:00:10:02 -0400] "POST /test/data.php HTTP/1.0" 200 175 "-" "-"
192.168.0.154 - [25/Oct/2021:00:10:02 -0400] "POST /test/sendtosocket.php HTTP/1.1" 200 250 "-" "python-requests/2.26.0"
192.168.0.144 - [25/Oct/2021:00:10:04 -0400] "POST /test/data.php HTTP/1.0" 200 175 "-" "-"
192.168.0.144 - [25/Oct/2021:00:10:05 -0400] "POST /test/data.php HTTP/1.0" 200 175 "-" "-"
192.168.0.144 - [25/Oct/2021:00:10:06 -0400] "POST /test/data.php HTTP/1.0" 200 175 "-" "-"
192.168.0.144 - [25/Oct/2021:00:10:07 -0400] "POST /test/data.php HTTP/1.0" 200 175 "-" "-"
192.168.0.144 - [25/Oct/2021:00:10:08 -0400] "POST /test/data.php HTTP/1.0" 200 175 "-" "-"
192.168.0.144 - [25/Oct/2021:00:10:09 -0400] "POST /test/data.php HTTP/1.0" 200 175 "-" "-"
192.168.0.144 - [25/Oct/2021:00:10:11 -0400] "POST /test/data.php HTTP/1.0" 200 175 "-" "-"
192.168.0.144 - [25/Oct/2021:00:10:12 -0400] "POST /test/data.php HTTP/1.0" 200 175 "-" "-"
192.168.0.144 - [25/Oct/2021:00:10:13 -0400] "POST /test/data.php HTTP/1.0" 200 175 "-" "-"
192.168.0.144 - [25/Oct/2021:00:10:22 -0400] "POST /test/data.php HTTP/1.0" 200 175 "-" "-"
192.168.0.144 - [25/Oct/2021:00:11:23 -0400] "POST /test/data.php HTTP/1.0" 200 175 "-" "-"
192.168.0.144 - [25/Oct/2021:00:10:24 -0400] "POST /test/data.php HTTP/1.0" 200 175 "-" "-"
192.168.0.144 - [25/Oct/2021:00:10:25 -0400] "POST /test/data.php HTTP/1.0" 200 175 "-" "-"
192.168.0.144 - [25/Oct/2021:00:10:27 -0400] "POST /test/data.php HTTP/1.0" 200 175 "-" "-"
192.168.0.154 - [25/Oct/2021:00:10:33 -0400] "POST /test/sendtosocket.php HTTP/1.1" 200 251 "-" "python-requests/2.26.0"
192.168.0.144 - [25/Oct/2021:00:10:55 -0400] "POST /test/data.php HTTP/1.0" 200 175 "-" "-"
192.168.0.144 - [25/Oct/2021:00:10:56 -0400] "POST /test/data.php HTTP/1.0" 200 175 "-" "-"
192.168.0.144 - [25/Oct/2021:00:11:01 -0400] "POST /test/data.php HTTP/1.0" 200 175 "-" "-"
192.168.0.144 - [25/Oct/2021:00:10:58 -0400] "POST /test/data.php HTTP/1.0" 200 175 "-" "-"
192.168.0.144 - [25/Oct/2021:00:10:59 -0400] "POST /test/data.php HTTP/1.0" 200 175 "-" "-"
192.168.0.144 - [25/Oct/2021:00:11:01 -0400] "POST /test/data.php HTTP/1.0" 200 175 "-" "-"
192.168.0.154 - [25/Oct/2021:00:11:05 -0400] "POST /test/sendtosocket.php HTTP/1.1" 200 251 "-" "python-requests/2.26.0"
192.168.0.144 - [25/Oct/2021:00:11:33 -0400] "POST /test/data.php HTTP/1.0" 200 175 "-" "-"
192.168.0.144 - [25/Oct/2021:00:11:34 -0400] "POST /test/data.php HTTP/1.0" 200 175 "-" "-"
192.168.0.144 - [25/Oct/2021:00:11:35 -0400] "POST /test/data.php HTTP/1.0" 200 175 "-" "-"
192.168.0.144 - [25/Oct/2021:00:11:37 -0400] "POST /test/data.php HTTP/1.0" 200 175 "-" "-"
192.168.0.144 - [25/Oct/2021:00:11:38 -0400] "POST /test/data.php HTTP/1.0" 200 175 "-" "-"
192.168.0.144 - [25/Oct/2021:00:11:39 -0400] "POST /test/data.php HTTP/1.0" 200 175 "-" "-"
192.168.0.144 - [25/Oct/2021:00:11:41 -0400] "POST /test/data.php HTTP/1.0" 200 175 "-" "-"
192.168.0.154 - [25/Oct/2021:00:12:08 -0400] "POST /test/sendtosocket.php HTTP/1.1" 200 251 "-" "python-requests/2.26.0"
192.168.0.154 - [25/Oct/2021:00:12:42 -0400] "POST /test/sendtosocket.php HTTP/1.1" 200 251 "-" "python-requests/2.26.0"
192.168.0.154 - [25/Oct/2021:00:12:43 -0400] "POST /test/sendtosocket.php HTTP/1.1" 200 251 "-" "python-requests/2.26.0"
192.168.0.154 - [25/Oct/2021:00:12:43 -0400] "POST /test/sendtosocket.php HTTP/1.1" 200 251 "-" "python-requests/2.26.0"
192.168.0.154 - [25/Oct/2021:00:12:44 -0400] "POST /test/sendtosocket.php HTTP/1.1" 200 251 "-" "python-requests/2.26.0"
192.168.0.154 - [25/Oct/2021:00:12:45 -0400] "POST /test/sendtosocket.php HTTP/1.1" 200 250 "-" "python-requests/2.26.0"
192.168.0.154 - [25/Oct/2021:00:12:47 -0400] "POST /test/sendtosocket.php HTTP/1.1" 200 250 "-" "python-requests/2.26.0"
192.168.0.154 - [25/Oct/2021:00:12:48 -0400] "POST /test/sendtosocket.php HTTP/1.1" 200 250 "-" "python-requests/2.26.0"
192.168.0.154 - [25/Oct/2021:00:12:49 -0400] "POST /test/sendtosocket.php HTTP/1.1" 200 251 "-" "python-requests/2.26.0"
192.168.0.154 - [25/Oct/2021:00:12:50 -0400] "POST /test/sendtosocket.php HTTP/1.1" 200 251 "-" "python-requests/2.26.0"
192.168.0.154 - [25/Oct/2021:00:12:51 -0400] "POST /test/sendtosocket.php HTTP/1.1" 200 251 "-" "python-requests/2.26.0"
192.168.0.154 - [25/Oct/2021:00:12:54 -0400] "POST /test/sendtosocket.php HTTP/1.1" 200 251 "-" "python-requests/2.26.0"
192.168.0.144 - [25/Oct/2021:00:13:11 -0400] "POST /test/data.php HTTP/1.0" 200 175 "-" "-"
192.168.0.144 - [25/Oct/2021:00:13:13 -0400] "POST /test/data.php HTTP/1.0" 200 175 "-" "-"
192.168.0.144 - [25/Oct/2021:00:13:14 -0400] "POST /test/data.php HTTP/1.0" 200 175 "-" "-"

```

Figure 32: Server Log Requests Frequency

The screenshot shows the phpMyAdmin interface for a database named 'remote_input'. A table is displayed with the following columns: id, current, voltage, and status. The table contains 23 rows of data. The 'id' column values range from 509 to 523. The 'current' column values are 125, 250, 375, 500, 1000, 125, 250, 375, 500, 1000, 125, 250, 375, 500, 1000, 125, 250, 375, 500, 1000, 125, 250. The 'voltage' column values are 250, 500, 750, 1000, 250, 500, 750, 1000, 250, 500, 750, 1000, 250, 500, 750, 1000, 250, 500, 750, 1000, 250, 500, 750. The 'status' column values are 200, 200.

id	current	voltage	status
509	125	250	200
510	250	500	200
511	375	750	200
512	500	1000	200
513	125	250	200
514	250	500	200
515	375	750	200
516	500	1000	200
517	125	250	200
518	250	500	200
519	375	750	200
520	500	1000	200
521	125	250	200
522	250	500	200
523	375	750	200

Figure 33: Back-End Server PHPMYADMIN Database View

Figure 28 shows a table on the Database created for input from the ESP module, there is an unlimited amount of columns where any type of data can be inputted.

8.3.7.1 Making a POST Request to the LAMP Server

As stated on the design portion of the document, the one and only purpose of the Interboard communication bus is of sending and receiving telemetry data and /or commands to and from the remote LAMP server. The system features a custom-made protocol to best handle the data in a secure manner with consideration and design practices in place to minimize data loss while also maintaining good latency for the type of inputs and outputs in place

where a hazardous condition can be suppressed manually and the latency resulting from end to end is estimated to be between one and two seconds.

Let's first consider transmitting telemetry data from the physical device to the remote server where this data is later fetch from the database and served in a user-friendly manner through a web application based GUI.

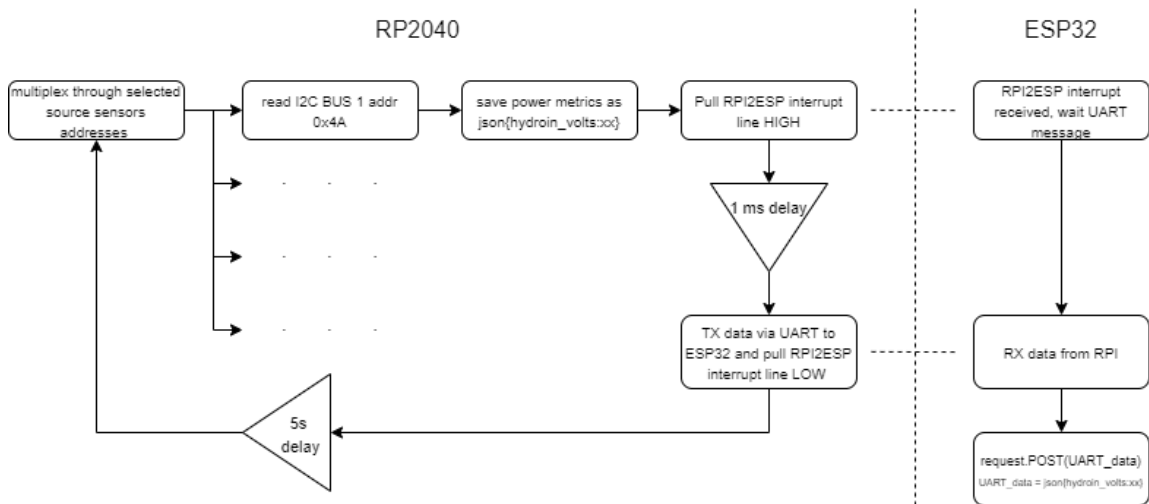

Figure 34: Sensor Reading, Interboard Communication and Server Request Software Flowchart

The data gathering starts with the reading of the on-system sensors and since every single source selection and bypass is software controlled, the software will at all times be aware of what source is being utilized at a given time as well as battery charge status and load utilization and selection if selected at all. This is why it is redundant and unnecessary to check all sensors at all times and instead just poll the sensors of the sources currently selected.

For our example, the source selected is the hydro system, where this sensor with address 0x4A is assigned to the Hydro generator. After the data is gathered it is packed in the JSON format with the corresponding JSON identifier label derived from where the data was gathered. JSON is utilized to minimize data loss and in order to comply with buffered items protocol proprietary of UART protocols. At this point the RPI2ESP interrupt line pulled high in order to announce incoming data to the ESP32, as good software design practice to minimize data loss and truncations, a 1 ms delay is introduced allowing the ESP32 to finalize any tasks and to arrive at a stable status to commence the data transmission. After the data is received, it is automatically sent to the server via standard HTTP POST request. After the UART transmission is finalized on the RP2040 side then a delay of 5 seconds is introduced to avoid causing bottlenecks on the network stream of the ESP32. Moreover 5 seconds is a good enough frequency of update for power metrics and arguably is long enough, but it is more than enough time to visualize the data at an almost real time rate. It is calculated that this whole process including both delays @133MHz, in about 5.002 seconds. The whole algorithm presumably takes about 20 instructions to complete which at the mentioned clock take about 0.156µs.

Shifting gears into the server backend once data is received, the data processing scheme on the server follows the following flowchart:

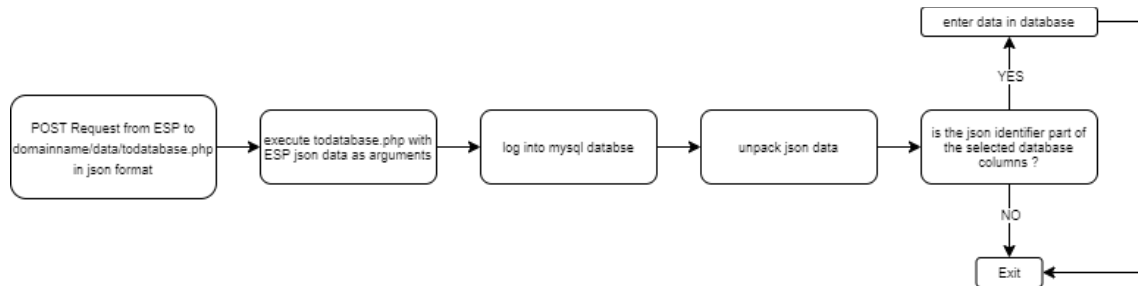

Figure 35: Server Request Handler Flowchart

In order to minimize the processing power used on redundancy the LAMP server is programmed to receive and unpack json packed dictionaries. The username and password are hardcoded into the PHP script as well as the database name and table name within that database.

8.3.7.2 GET Request to the LAMP Server

The ESP32 Wireless Communications Module has full capabilities to be configured as a server and not necessarily only as a socket. However, in our case for practicality purposes it will be configured as a socket endpoint. Having said that, our team has experimented with several methods in order to send or acquire data on the ESP32 such as the “socket” library in python. The problem comes because of the fashion in which data leaves the ESP32 module. From hands on experience we have learned that the socket protocol connection requires a stable connection without interruptions and if the connection is for some reason interrupted between the client and the server using the socket library, the whole connection has to be restarted and it comes at the expense of having difficulties such as port reusability and address reusability on the server side, given that the connection was interrupted and there was no chance to perform the protocolar “handshake” when ending the connection between the server and the client.

To mitigate the problems described our team came with the solution of initiating the acquisition of data from the ESP endpoint and not the other way around. Even though the flow of data wanted is from server to client, the final resolution was to have the ESP32 initiate this connection via classic HTTP GET requests to the server since this connection does not require a stable connection for an extended period of time and indeed it times out after x number of seconds preconfigured on the server on idle connections from clients.

The figure below depicts the custom-made algorithm to fetch commands / instructions from the server using GET requests initiated by the ESP32 Wireless Communications Module:

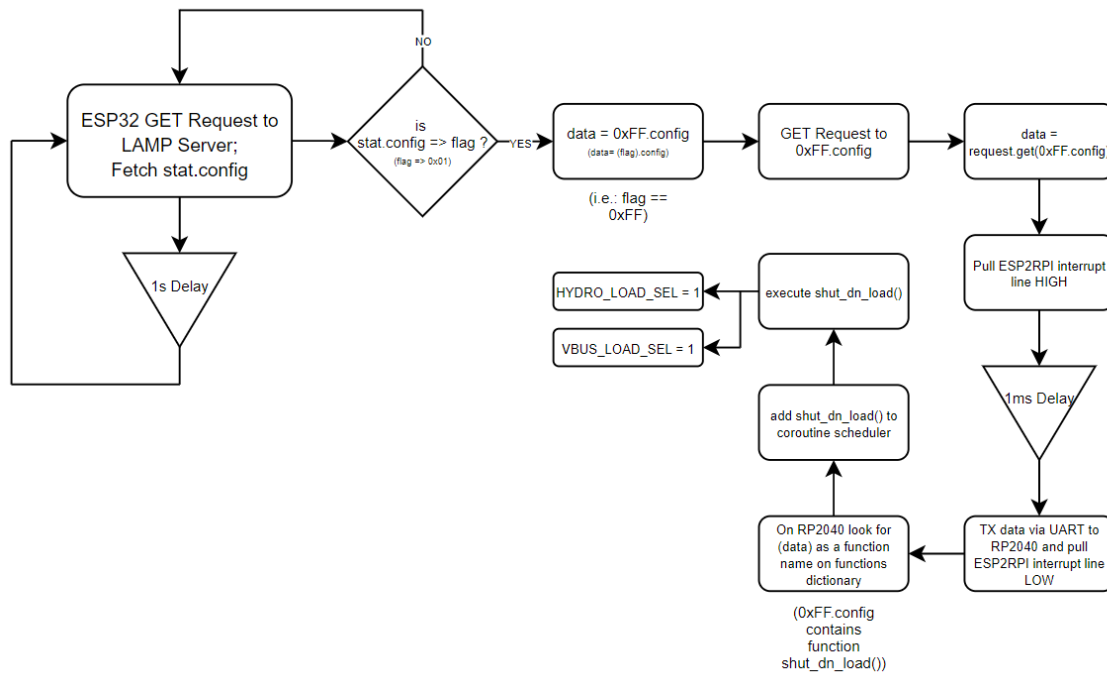

Figure 36: System Command Acknowledge using GET Request

Following the direction of the flowchart, the preconfigured file to be fetched by the GET requests initiated by the ESP32 module is called “stat.config”. stat.config is a user modified file that contains a hexadecimal code generated by the user input with respect of predetermined functions on the Web application based GUI which is discussed on the following section.

Whenever this file is checked for new commands from the user to the system, the ESP32 module will store the response as a hex number called the “flag” and it will compare it against the minimum value for allowed commands. As a practical example, and as expressed on the flowchart, if the flag value is 0x01 or less then there is no command to report to the system and the ESP32 will delay for one second and continue making GET requests every second, if the flag has a value greater than 0x01 then the flag itself identifies the following GET request to be made to the specific command configuration file. Next, the ESP32 module will make a GET request to the specific file that contains the function to be executed by the physical system interfaces. In our example case displayed on the flowchart, the 0xFF.config file contains the “shut_dn_load” function which turns off the voltage supply to all external loads being sourced by the system regardless of if there is a load or not.

It is worthwhile mentioning that all of the config files containing the functions to be executed by the physical system except for the stat.config file are locked by the server and are not editable by no one including the Apache Server administrator. Moreover, to ensure that the system does not get triggered twice by the same stat.config flag without user input, there is a PHP script present in the backend server that compares the time and dates the stat.config configuration file was last edited versus when it was last accessed and if the last access date is greater than the last time it was edited it will automatically overwrite the stat.config file to a default value of 0x00 in order to avoid retriggering the system.

After the ESP32 performs the GET request to the 0xFF.config configuration file (in this example) then the Interboard communication begins. The ESP2RPI interrupt line is held at a HIGH state, then a 1 ms delay is introduced, after which the UART transmission is performed from the ESP module to the RPI. In this case the function to be performed “shut_dn_load()” is matched with a functions dictionary after which it is executed which resulted on HYDRO_LOAD_SEL and VBUS_LOAD_SEL to be held high until further notice, since those selection circuits are active high in deactivating the load source voltages, refer to the Source to Load Selection paragraph for more information on the functionality of this logic circuit.

8.3.7.3 LAMP Server Front End & Back End Interactions

The user-friendly Web based GUI to monitor and introduce commands to the physical system features a total of six discrete functions and one dynamic function (Hydro Pump Speed Control) that can be sent to the system interfaces.

The figure below depicts the structure of the available predefined system functions as well as their mapping to the possible inputs to the stat.config configuration file:

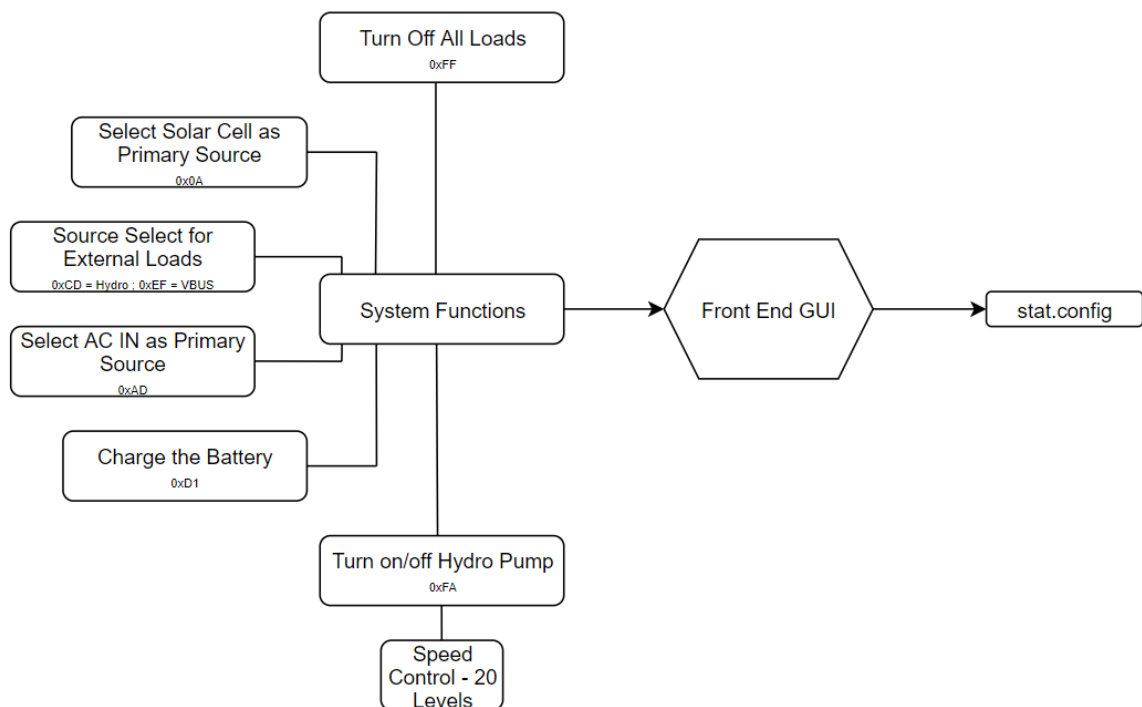

Figure 37: Front-End Server Functional Diagram

As seen on the example depicted on section 7.3.7.2, selection of the User Visible function “Turn Off All Loads” has as a consequence writing the hex code 0xFF to the stat.config configuration file. Which simultaneously points to the file 0xFF.config file containing the “shut_dn_load()” function to be fetched on the following GET request from the ESP32 Module. The same process if performed for all of the functions visible to the user after the user selects any of them. For all of the discrete functions, upon its receipt by the RP2040 module, it will simply toggle from the current state to the inverted state, hence no specifics on ON or OFF is required as far as the GUI side is concerned.

8.4 Software Development Environment

The software development environment section of this report will discuss the language, modules, and program writing environment chosen for this project. When considering the software development environment, a series of attributes and conditions were considered. For the purposes of this project, the chiefly desired attribute for the software environment was user friendliness. This attribute was sought after when choosing both the embedded program writing environment as well as the embedded software language of choice. When choosing the embedded software language, priority was given to high level languages with tools that would be useful in the debugging process. This is what lead to the choice of MicroPython as the embedded software language.

8.4.1 MicroPython Language

The development language that will be used for this project will be MicroPython. MicroPython is an extension of the Python language that is meant to be used for microcontrollers, where in the case of this project will be the Raspberry Pi Pico (RP2040). There are series of advantages to using MicroPython over lower languages such as C, which are all accomplished due to its ability to handle complex tasks in a far more efficient manner. Due to the nature of MicroPython being a high-level programming language, this allows the debugging and software modification process to be far more accessible and easier to understand. The lack of debugging direction and frustration normally experienced when writing embedded code in C will be mitigated when using MicroPython, due to the efficiency of commands used in the MicroPython language as well as the libraries that are available to it.

Another advantage of using MicroPython its built-in capability for exception and error handling. The embedded C programming language does not have exception and error handling, which can lead to long, drawn out debugging sessions with no direction as to what is causing the error and subsequently wasting time. The lack of exception and error handling in C can also lead to executions of programs that have the potential to fry components, leading to the necessity to purchase more materials than necessary and waste time as well. MicroPython has a far higher likelihood of mitigating these problems by having exception and error handling built into the compiler.

Having this capability allows MicroPython to stop program execution when an error is encountered in real time, as well as printing out the file and line number where the error occurred. This is an incredibly valuable tool for the development and debugging of the embedded software for this project, as it not only provides the location for the error, but also allows the debugging process to be streamlined into a top to bottom process. This means that with the location of the first error encountered being printed each time. This provides crucial information as to whether an attempt at fixing that specific error was successful, as the subsequent attempt at executing the code will either print the same error, indicating that the debugging attempt was unsuccessful; a new error indicating that the debugging attempt was successful and providing the location of the next error; or fully execute the program once all errors have been addressed.

8.4.2 MicroPython Libraries/Modules

The final great advantage of utilizing MicroPython for this project are the libraries that are available for this embedded language. While there are some libraries that are not necessarily unique to either Python or MicroPython such as “math” which is available in embedded C programming, there is a multitude of libraries that are unique to both Python and MicroPython respectfully. For the purposes of this project, only Python/MicroPython libraries that are necessary to be implemented into the software of this project will be discussed.

8.4.2.1 time – Time Related Functions

The first module used in this project will be the time module. This module provides functions for measuring the current time and date, measuring time intervals as well as for delays. This module will be integral to providing information to both the server as well as the software program for the system, as the nature of measuring the output of a power system requires it to be measured versus time. This module will also be necessary to providing delays and information as to how often to read values for each sensor, how often to check for abnormalities in the supply of power between each generator, as well as the capability to pause the system. The capability to pause the system is crucial; once an unexpected error or power supply issue that could be damaging to the system occurs, a relay will be engaged to isolate the relevant power source or power sources from the system. From there, a time function to make the system pause indefinitely and display an appropriate error message will be useful in both protecting the system by not allowing it to continue to try and operate, as well as for diagnosing purposes to be done while the system is still technically on.

8.4.2.2 uasyncio – Asynchronous I/O Scheduler

The uasyncio module will be integral to providing the software the ability to both schedule specific interrupts, organize events, as well as allow for multiple scripts to be executed simultaneously. In the previous section regarding the outline of the software for the system, it is apparent that there are multiple instances of scripts that will always be running. Examples of these include scripts that read the load of the system, power output of the solar panels, power output of the hydro-electric generator, etc. For the software to be able to monitor these values simultaneously in real time, this specific module will help to resolve potential issues. With commands such as “uasyncio.Event” multiple events in the software can be synched and run simultaneously, which will yield both sensor values that can be accurately mapped to the same timestamp, as well as reduce RAM usage for the microcontroller by condensing the script events.

8.4.2.3 machine – Functions Related to the Hardware

The machine module allows for the direct interface between the software and hardware components on the microcontroller. This specific module allows for the importing of the microcontroller’s pins so that they can be written to. This capability is incredibly important, as gathering information from any sensor or device that is physically interfaced with the microcontroller will require the machine module to interface with the data wires for each sensor/device. Another capability of this module is to allow the microcontroller to be reset

and enter its bootloader, which will be necessary when implementing each of the libraries needed for the microcontroller to interface with each connected sensor/device.

8.4.2.4 io – Input/Output Streams

The functionality of the io module mostly revolves around the creation, and allocation of data files for the system. One of the goals of the system, is to have a log of data values from the system that will be recorded and posted to the server portion of the system so that the system can be monitored remotely. With this module, the software will have that capability to open files and verify them before being sent over to the server. Having the ability to open and view the contents of the log file before being sent over will be crucial to verification and debugging purposes. Problems regarding not seeing updated values from the server can be checked first by verifying that the log file is being created and updated accordingly on the systems end, before checking the wireless components of the system.

8.4.2.5 rp2 – Functionality Specific to the RP2040

This rp2 module and its corresponding library functions will be helpful by providing commands and capabilities that are unique to the functionality of our microcontroller of choice, the RP2040. For the purposes of this project, the capabilities that have expressed interest are the functions that allow for the assembling of PIO programs, specifically those that control the initial state for the GPIO pins. Given that multiple GPIO pins will be used, as there will be multiple sensors and devices that will interface with the microcontroller, a tuple will be used to control the initial state of each relevant GPIO pin. Having this capability will assist in the initialization of the system each time it is turned on, verifying that the GPIO pins that are being used to interface with the microcontroller are operating accordingly. As for improving the system when all of the initial criteria is met, the library functions of this module also provide assembly language instructions that are specific to the RP2040 microcontroller, which could potentially help in optimizing simple instructions in the program in terms of clock cycles and power used for the instruction.

8.4.3 Thonny

Thonny will be the embedded program writing environment for the software of this project. There were three different embedded coding environments that were observed and evaluated, namely Pycharm, Code Composer Studio, and Thonny. Thonny was chosen based on its flexibility and capability to work with the types of programs that would be necessary to successfully program the system using MicroPython. Code Composer Studio lacked the capability to be compatible with writing and implementing code written in MicroPython. Pycharm, while compatible, had a lack of working consistency when downloading the program files onto the microcontroller. Thonny however, is both compatible with MicroPython programming, and was determined to be more consistent in successfully implementing code on the microcontroller. In addition to these basic necessities, Thonny has some additional capabilities that allow for smoother debugging sessions, as well as tools to manage modules and libraries needed in the program.

The first additional capability that influenced the decision to choose Thonny as the embedded software environment of choice was the plug-in functionality. With plug-ins,

coupled with a plug-in search engine that searches PyPI, the Python Package Index which is a repository of Python based software, additional modules and libraries that would be needed for the project can be easily searched and added as a plug-in. This helps greatly when situations arise where sensors and additional hardware interfaced with the microcontroller requires its own set of library functions to be accessed, which can easily be searched and implemented through the Thonny plug-in manager.

Another capability that while not necessarily unique to just Thonny, does allow for help in debugging and operational testing is the Thonny shell environment. The shell, using a REPL allows for directly interfacing with the microcontroller via a command line, which is a fantastic tool for testing and debugging code. Each command input in the shell environment is flashed to the microcontroller, where the input can be observed and evaluated by the program and will return an error if an error occurs.

9.0 Marketing

Our design is set to be used by the average homeowner. This system will be helpful to each the homeowner and the power company. This allows us to market the system to both sides, with the possibility of increase its value. For the homeowner, the design will generate savings on the utility bill. This is a part of every homeowner's everyday life. From purchasing energy saving appliances to the simple act of turning the lights off when not in a room. All homeowners look for ways to lower their power bill. Power companies are always looking for ways to decrease the cost of producing energy. Green energy is becoming a marketing strategy that they are using to pitch their systems to homeowner. With current laws, power companies have to connect any person power generation systems to the power grid. If any extra power is generated, then the extra is transferred to the grid. This process, benefits both the power company and the consumer.

Within any design process, the thought of generating revenue with the product is highly considered. There are many factors that go into researching the marketing of a product design. Including target consumer and method to reach a customer are always at the top of the list. Without knowing who would use the product or how it will reach the same person. It will remain difficult in knowing if continued funds for the project will remain. Many designs have been discontinued due to low market value.

9.1 Marketing methods

In the technology age, marketing is all around consumers without them even thinking about it. From the simple commercial to the use of social media. Ads are constantly all-around potential buyers. For an energy system, two main forms of advertisement are the use of commercials and social media. Each comes with its own unique target consumer. Where commercials give the user a quick, but effective, demonstration of the device or product. It has limited reach of consumers. Social media can reach people worldwide at a given second, but it limited to how much information can be put out. It is up to the consumer to then go and do their own research of the product.

9.1.1 Commercials

One of the oldest forms of marketing is the use of commercials. Television commercials are an effective way of attracting bring new customers to a company. With the increase of solar energy popularity, there has been an increase in solar panel commercials. The use of commercial gives the customer both a visual of the product and quick stats of the performance. One drawback is, they are only a few seconds long. Therefore, they must be able catch the interest of anyone that is looking, or even thinking about the product. Because of the standard length of a commercial, only information that will attract a user can be shown.

For this design, commercials can be written for two different potential customers. First, is the homeowner. These commercials will show how much energy savings they can gain. Factoring the battery bank being used, other factors could include use during non-solar generation times. Location would play a part in determining how the commercial would reach the homeowner. Natural disasters have always been an interruption of power on a

grid. Therefore, the commercial would demonstrate how the power would stay on in your home. Even when the power lines have been disconnected for any reason.

9.1.2 Social Media

One of the newer forms of marketing is the use of social media pages. Every day, more people are creating different social media pages. With new ones being created by the day. As of today, the use of social media for marketing has become to most effective method in getting new products to a customer. One the larger companies, like Facebook, sell ad space to companies. These spaces can by instantly directed to a customer's page when the use other search engines to look up a product. For example, let's say a homeowner is interested in solar panels for their home. They begin to look up what type would be best for them. From here ads will begin to appear on the social page of the customer. Giving them actual company names along with the product. All the user has to do, from here, is click on the company's page. Where they can talk to representatives, or just simple do research on the product they want.

9.2 Target Audience

In marketing know who you are designing the product for, allows the company to see if there is potential in sells. If you were designing a product for a dog owner, but the customers in the area own cats. Then the design would not be very marketable to them. Therefore, companies spend hours and dollars on marketing research. For our design, the target audience would be for two types of people. Those that want to generate green energy, or someone who wants to save on an energy bill. Because power companies give credits to homeowners that generate solar energy. This system would benefit for consumer and company. Being able to produce power during peak and non-peak hours, has the potential for generating revenue for both parties. Not to mention revenue that is created during the manufacturing of the system.

To determine who, the target audience will be, research groups use focus groups. These groups' main objective is to answer a series of question about the product that will show many paths a company can take in selling the product or even who to commercialize it. Every product comes with a different answer to this research. It's the focus groups job, to identify who would benefit from the product and ways to reach all potential buyers. After many years of trial and error, today's focus groups have the process of getting this answer down to highly accurate system.

9.3 Market Uses

Before product researchers can obtain who would use the product, they have to find all the uses of the product. This is why most marketing research is done after a fully developed design has been done. For this product, the uses are obvious. A homeowner would use this design to generate power for personal use. However, that is not the full use of this system. Depending on how high the system is scaled. There can be a range of uses of this system. One market use is how the power can be used by either solar generation or hydro generation. Each method can be used while normal power delivery systems cannot perform. With the use of the hydro, we added in an extra power use. Because of the

limitation of both solar and hydro power, by working together they make up for each other's disadvantage.

Because building a full-scale system would be difficult for showing the system for some forms of marketing. The smaller scaled version would still be beneficial. This size of the system would allow for the marketing team to transport the system for display. This is another method for companies to show a product. Many expos have new system ideas that are shown during the time slots, or booths. These expos attract all different types of cliental. The use of the smaller version would allow for a quick packing and unpacking of the system for demonstrations.

10.0 System housing and construction

Protecting and controlling environmental hazards is a problem with any system that is in constant outside environments. With this design, all components will be left outdoors. Therefore, steps must be taken to keep the parts in working conditions. Wind, heat, water is some of the damaging factors we have need to protect the whole system from. Some components will need extra protection for tipping and falling. Any accidental damage that can happen must be reduced to a minimum. Another reason for designing a housing is for the ease of troubleshooting. Having all the components in a centralized location, will make finding system malfunctions faster. Therefore, adjusting the design will also become shorter. Although, it may seem a small part of the system. A good structural design can help in other parts and in future improvements.

10.1 Solar panel

Solar panels must set in certain areas to get the maximum output. When a customer decides to purchase a solar system. The company they choose will come out and do position research. From here the finds will provide both the customer and company, with the places in the area where the solar panels will be at the highest efficiency. With this design the solar panels are small, and it will be able to move from place to place to get the desired wattage. Also, the angle of the panels is another part of positioning. Panels are aligned with the curvature of the earth, to absorb the largest number of light rays from the sun. With the chosen panels, for the design, the mounting bracket allows us to place the panels in any angle we need.

Once we have placed the best location for the panel, we have need to construct a safe and secure mounting frame. If the frame is undersized, or made of the wrong material, then damage can occur. Damage will be the main point of failure of the solar panel. Ways the panel could be damaged are tipping from the weight, wind pushing the structure over, or something running into the panel. With a properly designed frame, we can eliminate these threats. This solar panel has some weight to it, but not enough to have the need of a full metal frame. It will also be stored in an inside location, when not in testing or demonstrating phases. A simple square structure would provide enough protection from tipping over.

10.2 Micro-hydro generators

For this design, we decide to build a simple housing unit for the generators. We have begun by mounting the units inside a five-gallon bucket. The bucket will act as a both support and a barrier from outside hazards. The bucket will also be the housing container for the water. For extra support on the generators, metal or plastic brackets will be installed inside. This will give the generators a flat surface to mount on. Curved surfaces can cause cracks, on the bucket, when the mounting screws are tightened. Using a thin metal bracket, we can round out one side. This will give a flush mounting and provide more support should a hazard occur. The pump that provides the water, will be submerged at the bottom of the bucket. Since we are not worried about the support for this component, it will be safe to leave it just sit without any extra support needed.

When running all wires for both the generators and the pump, will need to run from inside to the outside of the bucket. To reduce the chance of a shock occurring, it will be better to make all electrical connections on the outside. By the NEC, in a wet environment all wires by passing through any surface material by waterproof connectors. These connectors will prevent any water from splashing onto the external connections. What in storage the bucket will be place in an indoor area with an open lid. This will allow for all excess water to evaporate away. Thus, keeping the generators dry and reduce the possibility of corrosion.

10.3 Control boards and Microprocessors

Heat and water are two damaging problems for any circuit board. Water can come in the form of moisture or rain, when in an outdoor area. There are a few steps we can take to prevent both of these environmental factors from damaging our system. First step is keeping all electronic controls in an outside rated equipment box. These boxes are designed to keep both water and moisture away from the control boards. If any amount of water gets on the PCB, then either corrosion or an electrical short could occur. Most outdoor rated boxes are made of a plastic material and use a rubber seal on the door to make them waterproof.

Also, it should be noted that any electronic devices that are outside, have be placed inside this type of rated of a box to comply with NEC (National Electric Code). Any wires that will be coming in, or out, of the box will need to be attached by using waterproof connectors. This another NEC violation if any other type of connector is used. Inside the box, the boards will need to be properly secure. Back planes are the preferred method of attaching any board to a flat surface. The use of a back plane also allows for air to pass around the electronics. Helping to keep them within working temperatures.

We actually ended up just wood working a box with a 3D printed lid to house our system. While working on our system, we ended up taking a long time to get all the software working and unfortunately, the high quality enclosure for the PCB and battery housing was one of the last things we worked on because it was simply not as essential to the project as getting other stretch goal functions completed properly. The wood housing was well made with a large slot for our battery to fit and both of our PCBs to be mounted on either side with a safe distance between all of them. The 3D printed lid was very high quality and was removable, allowing one to see the insides of the project at will as well.

10.4 Load housing

Once we have the supply power system set up, we need to a way to prove the system is working. This comes from the load we have connect to both sources. With the addition of the DC to AC inverter, we have been able to run most devices that require 120 volts. Our main source of will be in the form of lights. This is the best source to add more or take away as our design requires. Using a plain board, we have been mounting light sockets to it. The with holes drilled at the center of the socket, the wires will be running along the back of the board. All connections will be hidden from sight, giving a clean look for the system. Depending the number of lights, we need to connect will depend on the number of sockets that will be required. However, one thing is known about the load circuit. The lights will be wired in parallel. This will prevent one light from shorting out the circuit. The

sockets will be made of porcelain base, with a screw type socket. This will allow us to use any form of light. Although, LEDs will be the best choice for a low voltage system. With having the inverter installed, and to keep cost down, we can install incandescent. Mounting all light sockets to the board will allow us to use any number of them. Keeping in mind, there are only so many we can attach to the power sources. Because of this limitation, it is best if we use one or two of them. Also, this number depends on which type of light we decide to use. Although, incandescent light bulbs are cheap and easy to get, they do draw a large amount of power. LED's have a lower power rating but come at a higher cost. Both of them will use the same type of socket base. Therefore, it would be best for the project to select the LED light bulbs as our primary load source.

11.0 Administration

Here, we have listed our project milestones and funding requirements and predictions. As an essential part of every project, our milestones and funding require us to constantly be mindful of our project goals and timing needs. It is also important for us to remember that our project milestones and budget affect all of us no matter our role in the project.

11.1 Project Milestones

Number	Milestone	Planned Completion Week
1	Test/solve second power source constraint	8
2	Have both power sources producing required power	9
3	Interface RP2040 with Power Sensors	10
4	Interface power sensors/RP2040 with power sources	11
5	Interface system with load components (provide power to end customer)	12
6	Develop Code that controls operation of power sources	13
7	Design PCB 1.0 and Order	14-16
8	Implement and test PCB 1.0	17
9	Design PCB 2.0 and Order	17-19
10	Implement system with designed PCB	18-19
11	Design and Build Final Model	19-22
12	Final testing and revisions	19-END

Table 16: Project Milestones

11.2 COVID Restrictions & Alternative Meeting Strategies

Due to restrictions and health concerns brought on by the COVID-19 pandemic, it was necessary to devise alternative meeting strategies. The primary meeting tool that was utilized to accommodate health concerns was the platform Discord. Discord is a Voice over Internet Protocol (VoIP) application that allows for instant messaging, digital distribution, and voice calling. Using this application, a server was created to house all aspects that are necessary to conduct meetings and send information to one another in an effective manner. Correspondence logs could be maintained and organized into text channels that focus on varying aspects of the design process including schematics, report, design-ideas, etc. A voice channel was also created where users/design team members could enter and engage in meetings via a personal microphone. While this tool was heavily utilized within the design and report writing process, it was still necessary to conduct meetings in person to test/prototype various components of the system. While meeting indoors, each team member took appropriate precautions as advised by the CDC to prevent the potential spread of COVID-19, including distancing at least six feet apart from each other as well as wearing facial coverings. Meetings with faculty regarding the design process as well as report checkmarks were conducted via the meeting platform Zoom.

11.3 Budget and Funding

Our budget will be self-funded, and when assessing estimates of component costs for the project, it appears very affordable. Equipment malfunction and breakage should be accounted for due to the nature of this project involving power generation, so all PCB, sensor, and software development parts have an increased quantity requirement. Based on these requirements, the cost estimate for this project can be evaluated using the estimated component costs located below.

In this section, we ended up needing to reprint our PCBs once we had them redesigned after the first printing was essentially a disaster on the companies part, so we ended up closer to \$600 for our project costs. Alongside this, we also had to repurchase some components for our boards and our housings cost more than we thought it would. This all led to a project that was more expensive than we could have anticipated, but we were okay with this unexpected cost as it led to a more fluid product overall, even at the cost of over \$100.

Item	Quantity	Cost Estimate
Raspberry Pi Pico (RP2040)	3	<=\$14
5v-12v small submersible water pump	1	\$12
12v-24v DC submersible water pump	1	\$50
Custom PCB	3	\$30-\$100
Universal DC Water Turbine Generator	2	<=\$30
20 Watt 12v Solar Panel Kit	1	\$42
LCD Display	1	\$5-\$40
Battery Bank	1	\$30-\$50
Voltage/Current/Power Sensor	2	\$27-\$35
LED lights	100	\$6
100W Voltage Regulator	1	\$15-\$35
Relay	1	\$9
Waterproof Flow Rate Sensor	1	\$10-\$19
Temperature Sensor	1	\$10-\$19
Battery Charge Regulator	1	\$20
DC-AC Power inverter	1	\$40
TOTAL (Estimated Range)	N/A	~\$320-\$521

Table 17: Budget and Funding

11.4 Facilities and Equipment

For this project the facilities and equipment necessary to test, prototype, and ensure the safety for team members involved are standard. The building environment for the project took place within the residencies of each of the team members, as several capabilities and aspects for the project could be individually developed (hardware, software, server, etc.). Given the nature of this project involves power distribution, proper testing equipment such as a multimeter will be necessary to verify voltage and current inputs and outputs of the system. Likewise, proper safety equipment is also needed to ensure the safety of team members when prototyping and performing operational tests of the system.

Considering the risk of working with a prototype power system, a fire-extinguisher is always within a range of ten meters of a team member during operational testing in the event of an electrical fire. Team members are also equipped with eye protection as well as fire resistant clothing to protect themselves from any potential harm. Prototype demos and operational tests are performed in a well vented facility with approximately twelve square meters of space and concrete floors to reduce the risk of fire and other potential risk factors.

11.5 Build, Prototype, Test, Evaluation Plan

The methodology employed to carry out the construction, prototyping, testing, and evaluation of the project will follow the project milestone schedule. This section will discuss the general methodology for carrying out each phase of the project, discussing the logistics and unique milestones associated with each phase.

11.5.1 Build Plan

Once the initial design and part selection is completed, the build process can begin. The initial build process will take place over the course of five weeks, where a divide and conquer approach will be taken to develop different sections of the project, including the hardware, software, and the server capabilities. The most important milestone to achieve in this phase of the project is to get each individual physical element of the project to operate in accordance with how it is supposed to behave within the scope of the project. This involves the testing of each of the sensors, the power output from both the hydro-electric generator and the solar panels, the capacity/recharge rate of the batteries, etc. The software development goal for the build plan is to be able to interface each of the necessary hardware components individually with the microcontroller, allowing for the eventual interconnection between each of the hardware and software elements in a way that is co-dependent on each other and can draw information from each other. (ex. Granting the ability for the light sensor readings to affect whether the solar panels are engaged.)

11.5.2 Prototype Plan

Once the initial build process is complete, most especially on the front of hardware and software the prototyping phase can begin. The scope of the prototyping phase of this project involves the gradual and sequential interfacing between the hardware elements and the software elements. This will involve developing the capability for each of the sensors to interact and control the operation of the power elements of the system, developing the

capability for values and variables from the system to be uploaded to the server portion of the project for remote observation, as well as developing the ability for each of the safety features of the system to be reliable and operational i.e. the relays. It is also in this phase in the project where the initial PCB design will be developed, which is conducive to the state the project will be in this phase. With each of the software and hardware components operational, it is in this phase where an effective PCB design prototype can be created.

11.5.3 Test Plan

The test plan phase of this project will involve the successive operational testing of the best optimized prototype that meets all of the hardware and software requirements of the project. This phase will focus on the reliability and consistency of the system, ensuring that power can be reliably generated from the system power generators under the correct specified conditions, stored when necessary, successfully into the battery bank; as well as allowing power to be delivered successfully and consistently to the load of the system. It is in this phase where a second or if necessary a third iteration of the PCB design can be implemented, as operational errors and anomalies will expectantly arise as the system as a whole is tested. The focus of this phase is to also optimize the system to most effectively operate within the scope of the system requirements, optimizations in software development, hardware organization, PCB design is to be expected within the scope of this project phase.

11.5.4 Evaluation Plan

The evaluation plan of this project will compare the capabilities of the finished project with the requirements set forth in the hardware and software requirements sections. The success of the project will be determined based on whether each of the hardware and software requirements are met. The evaluation plan phase, similar to the test plan phase will aim to answer the question of whether the system is optimized to the greatest extent possible, and if not, find why it was not feasible. Evaluating the project as a whole also involves evaluating the use cases of the project and whether it is feasible to scale this project up to successfully power an average home as this project originally aimed to model. Consequently, the power efficiency rating of the system will be a very important metric to consider when evaluating the feasibility of the system. While it is not an explicit requirement that this system be power efficient, this metric will be important to consider when evaluating the challenges this type of system would face if implemented into full scale households.

[OBJ]

[OBJ]

12.0 Conclusion

As we were designing this power system, we came across many constraints. One constraint, efficiency, was something we knew from the start would be our biggest issue. With this in mind, we decided to still pursue this type of system. Leaving efficiency out of the equation, we were able to design a sustainable system, using solar as the main source of power, and having hydro to supply power when solar was unavailable.

Although technology over the years has improved with solar and hydro power generation, more research and improvements are still needing to be done. With future improvements to this type of technology, eventually we believe that the efficiency will be high enough to make this system work in many locations for power generation. Especially with the special growing need for more self-sustained power systems growing in popularity.

One reason we choose this project is to gain a better understanding of how different generation methods can be used together. Current methods of power generation are being phased out in today's market. Power companies, and consumers, are looking at alternative ways to meet the power needs of a growing population. In order to meet this need, our project was looking at another method that could help to solve this problem.

Many power companies use both methods of generating power. Solar is becoming used in more areas than before. Hydro power has been used for many years and has become one of the best ways of generation during peak times. With this in mind, we decided to build our system combining these two systems. Each system, on its own, has limitations of how long they can generate. Taking the limitation of one, and supplementing the other in its place, prove to be a potential method in power generation.

This project has potential to become used for personal generation as technology improves. Currently the best efficiency we could obtain is close to 60 percent. Because when you change energy from one form to another. As technology improves, this rating has the potential to increase. Making our system efficient enough to allow the homeowner to generate enough power to supply individual needs. Even has the potential to produce extra power to feed into the current grid system. Therefore, making each home a generation plant to supply power to a larger growing demand.

References

- 1) "Product". Topsolar-Energy.Com, 2021, https://www.topsolar-energy.com/product_view.asp?id=363.
- 2) Topsolar-Energy.Com, 2021, <https://www.topsolar-energy.com/upimages/20179251056602827.pdf>.
- 3) notes, electronics. "Li-Ion Battery Advantages / Disadvantages: Lithium Ion » Electronics Notes". Electronics-Notes.Com, 2021, https://www.electronics-notes.com/articles/electronic_components/battery-technology/li-ion-lithium-ion-advantages-disadvantages.php.
- 4) notes, electronics. "How Do Lead Acid Batteries Work: Lead Acid Technology » Electronics Notes". Electronics-Notes.Com, 2021, https://www.electronics-notes.com/articles/electronic_components/battery-technology/how-do-lead-acid-batteries-work-technology.php.
- 5) Core.Ac.Uk, 2021, <https://core.ac.uk/download/pdf/16361877.pdf>.
- 6) "Redox Flow Batteries' Advantages For Stationary Energy Storage Market". Idtechex, 2021, <https://www.idtechex.com/en/research-article/redox-flow-batteries-advantages-for-stationary-energy-storage-market/20342>.
- 7) https://www.espressif.com/sites/default/files/documentation/esp32-wroom-32_datasheet_en.pdf
- 8) <https://datasheets.raspberrypi.com/rp2040/rp2040-datasheet.pdf>
- 9) https://www.ti.com/lit/ds/symlink/tlv3501.pdf?ts=1635821530774&ref_url=https%253A%252F%252Fwww.ti.com%252Fproduct%252FTLV3501
- 10) <https://www.electronicshub.org/classification-of-relays/>
- 11) <https://amperite.com/blog/relays/>
- 12) <https://en.wikipedia.org/wiki/Relay>
- 13) <https://components.omron.com/relay-basics/basic>
- 14) <https://www.sparkfun.com/datasheets/Components/LM7805.pdf>
- 15) https://en.wikipedia.org/wiki/Voltage_regulator
- 16) <https://www.digikey.com/en/maker/blogs/2020/what-is-a-voltage-regulator>
- 17) https://en.wikipedia.org/wiki/Rechargeable_battery
- 18) https://en.wikipedia.org/wiki/Electric_battery
- 19) <https://onlinelibrary.wiley.com/doi/abs/10.1002/adfm.202008783>
- 20) https://en.wikipedia.org/wiki/Zinc-ion_battery
- 21) <https://www.sciencedirect.com/topics/engineering/nickel-metal-hydride>
- 22) <https://www.sciencedirect.com/topics/engineering/charge-controller>
- 23) <https://www.donrowe.com/power-inverter-faq-a/258.htm>
- 24) <https://eepower.com/resistor-guide/resistor-types/photo-resistor/#>
- 25) <https://www.fierceelectronics.com/sensors/what-a-flow-sensor>
- 26) <https://www.fierceelectronics.com/sensors/what-a-temperature-sensor>
- 27) "BETTER KNOW YOUR BATTERY: Part One". 18650 Battery | BATTERY BRO, 2021, <https://batterybro.com/blogs/18650-wholesale-battery-reviews/18443999-better-know-your-battery-part-one>.
- 28) 3Yq5q42rw3z48qnbj46yehrx-Wpengine.Netdna-Ssl.Com, 2021, <https://3yq5q42rw3z48qnbj46yehrx-wpengine.netdna-ssl.com/wp>

- content/uploads/2018/06/BK1100FHU-Spec-Sheet-Panasonic-BK1100FHU-NiMH-battery-has-an-ambient-discharge-range-of-30-to-85.jpg.
- 29) <http://www.fsec.ucf.edu/en/certification-testing/solarstandards/index.htm>
 - 30) http://www.fsec.ucf.edu/en/publications/pdf/standards/FSECstd_203-17.pdf
 - 31) <http://www.fsec.ucf.edu/En/publications/pdf/FSEC-Certification-Small-System-Memo-2014-11-21.pdf>
 - 32) <https://www.cesa.org/wp-content/uploads/Standards-and-Requirements-for-Solar.pdf>
 - 33) <https://www.tooltexas.org/wp-content/uploads/2018/08/2017-NEC-Code-2.pdf>
 - 34) <https://www.usaid.gov/energy/powering-health/technical-standards/lead-acid-batteries>
 - 35) <https://standards.ieee.org/standard/485-2020.html>
 - 36) <https://standards.ieee.org/standard/937-2019.html>
 - 37) 2021, <https://www.igs.com/energy-resource-center/energy-101/how-much-electricity-do-my-home-appliances-use>. Accessed 9 Nov 2021.
 - 38) <https://webstore.iec.ch/publication/25678>
 - 39) <https://standards.ieee.org/standard/1020-2011.html>
 - 40) <https://www.mclpcb.com/blog/ipc-standards-for-pcbs/>
 - 41) <https://www.ipc.org/ipc-standards>
 - 42) <https://www.nfpa.org/NEC/electrical-codes-and-standards>
 - 43) <https://www.osha.gov/laws-regs/regulations/standardnumber/1910/1910.305>
 - 44) <https://isocpp.org/wiki/faq/coding-standards>
 - 45) https://en.wikipedia.org/wiki/Technical_documentation
 - 46) <https://www.iso.org/ics/01.110/x/>
 - 47) <https://spectrum.ieee.org/boschs-smart-virtual-visor-tracks-sun>
 - 48) https://en.wikipedia.org/wiki/Liquid-crystal_display
 - 49) <https://www.ecmag.com/section/codes-standards/pv-installation-codes-and-standards>
 - 50) https://en.wikipedia.org/wiki/Comparison_of_wireless_data_standards
 - 51) https://en.wikipedia.org/wiki/IEEE_802.11
 - 52) <https://www.espressif.com/en/products/socs/esp32>
 - 53) <https://www.technology.pitt.edu/help-desk/how-to-documents/wireless-network-standard>

Complete System Schematics

Senior Design I System Schematics

All designs were our own. Created and theorized by Chris Cruz-Paez, who worked in circuit design and redesign for many years.

First section dedicated to design of PCB for senior design 1 and first revision. Second section is dedicated to design of split PCB after power and sensor functionality was split between the two for cost and for ease of printing.

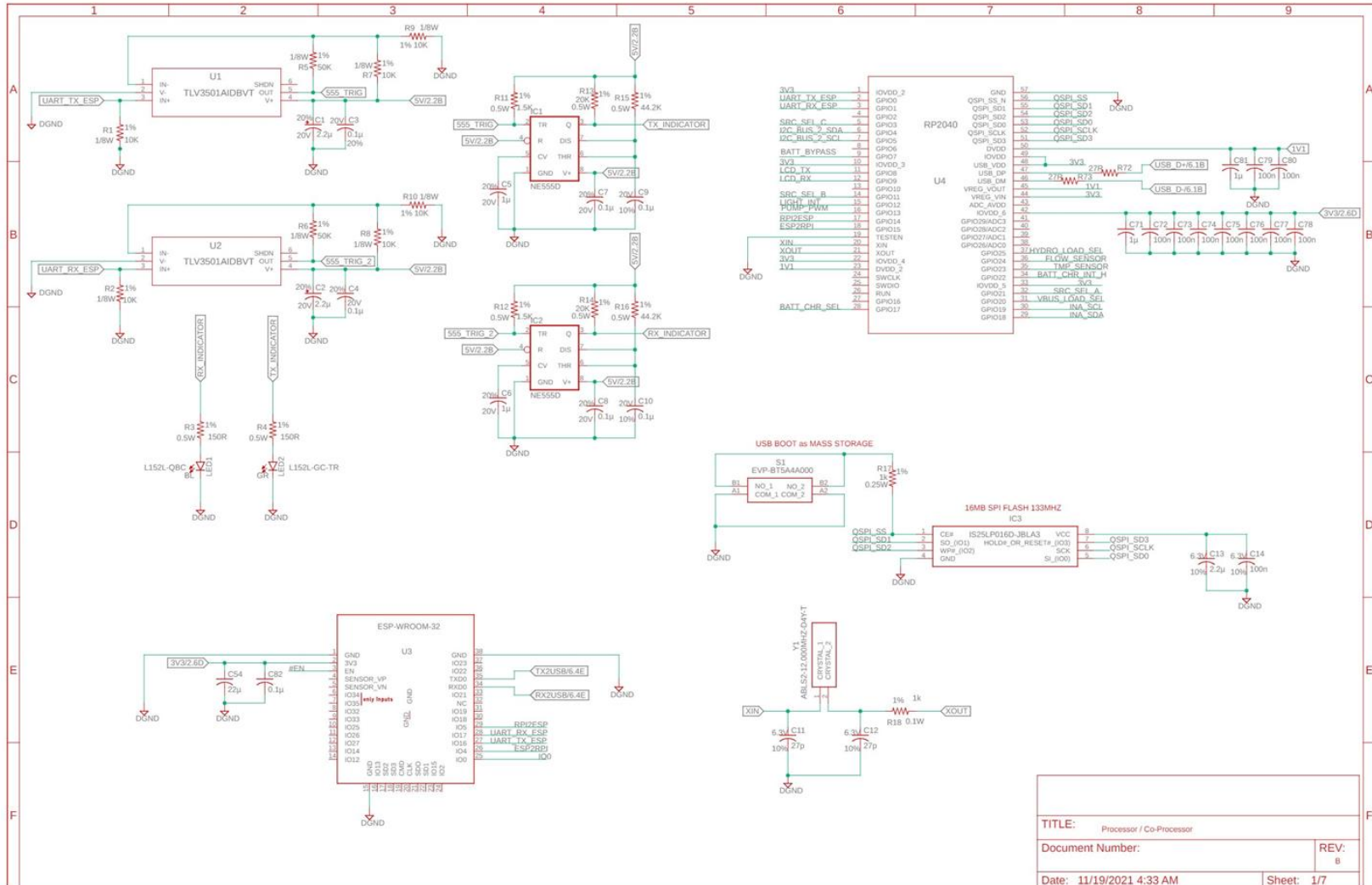

11/19/2021 5:11 AM f=0.94 C:\Users\chris\Documents\EAGLE\projects\SD\SHEET1.sch (Sheet: 1/7)

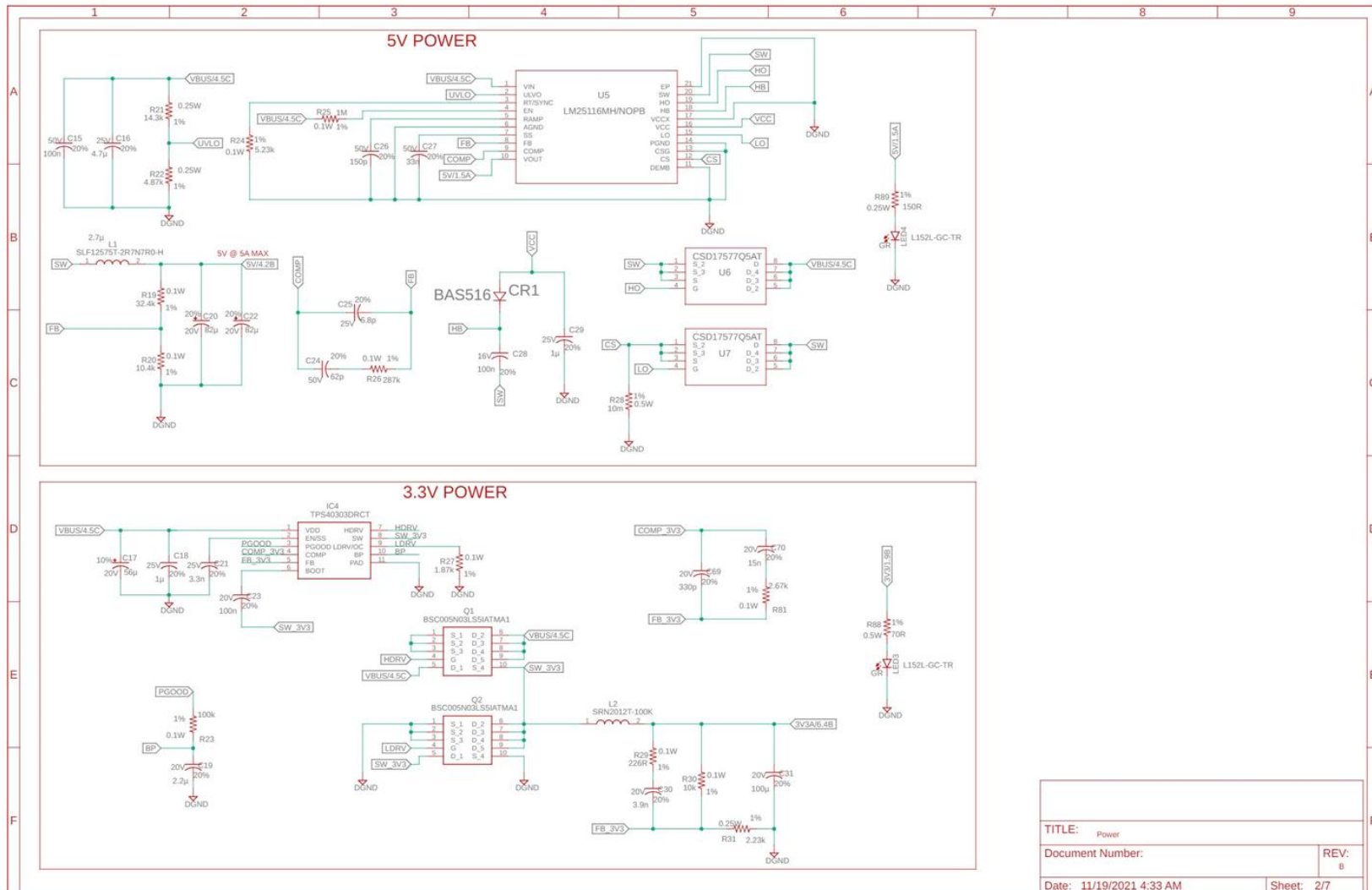

11/19/2021 5:11 AM f=0.94 C:\Users\chris\Documents\EAGLE\projects\SD\SHEET1.sch (Sheet: 2/7)

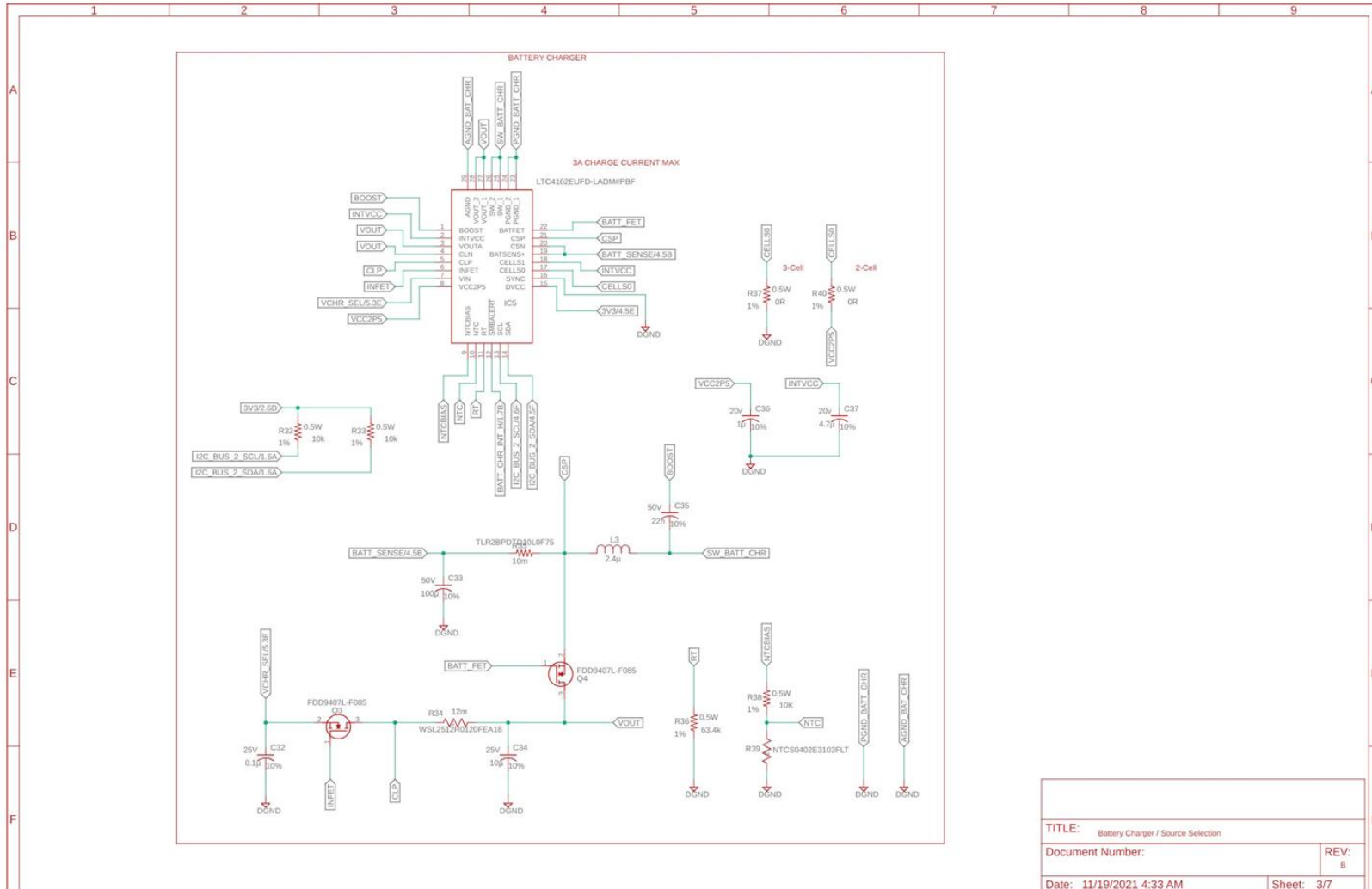

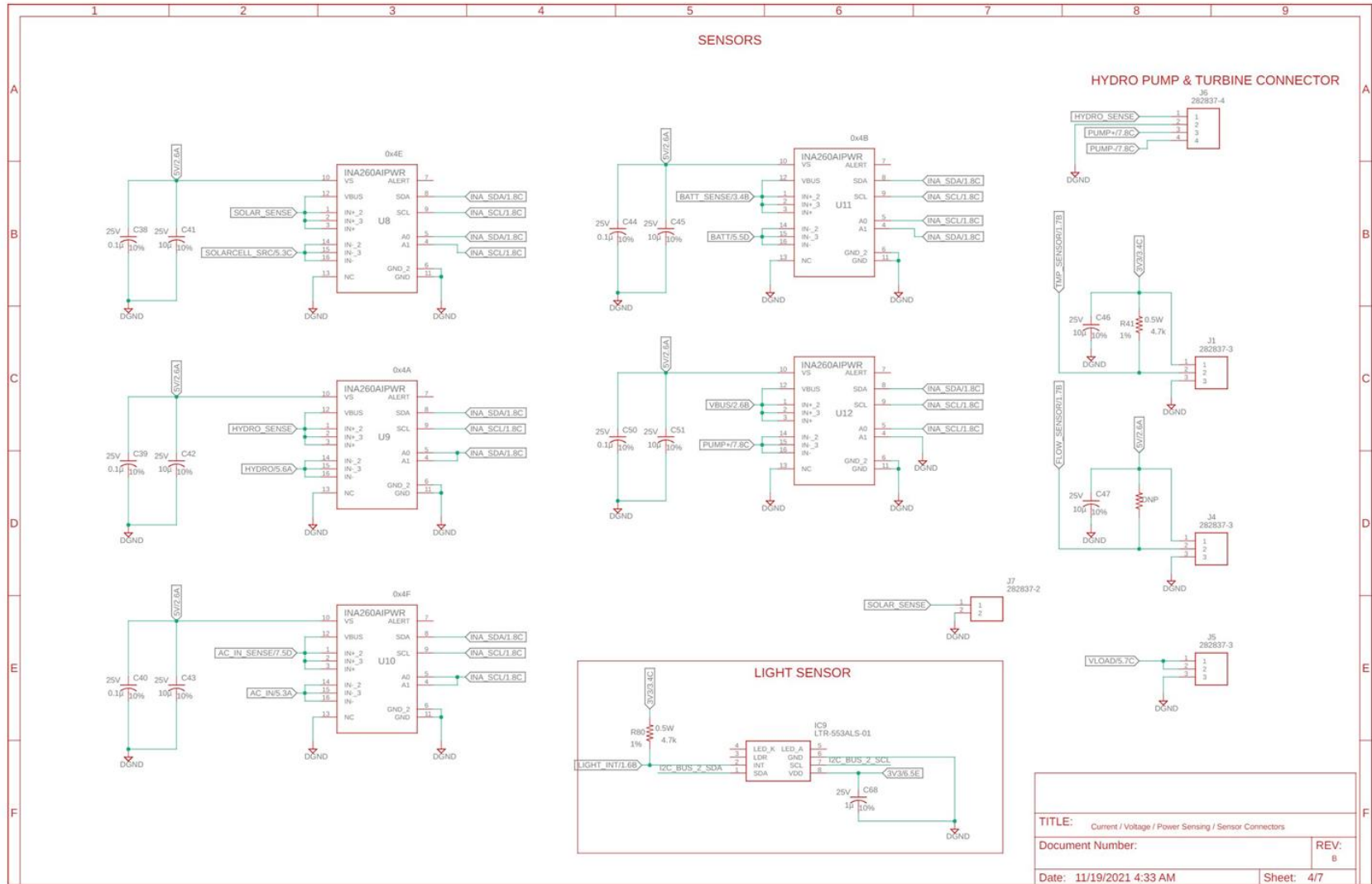

TITLE: Current / Voltage / Power Sensing / Sensor Connectors	
Document Number:	REV: 8
Date: 11/19/2021 4:33 AM	Sheet: 4/7

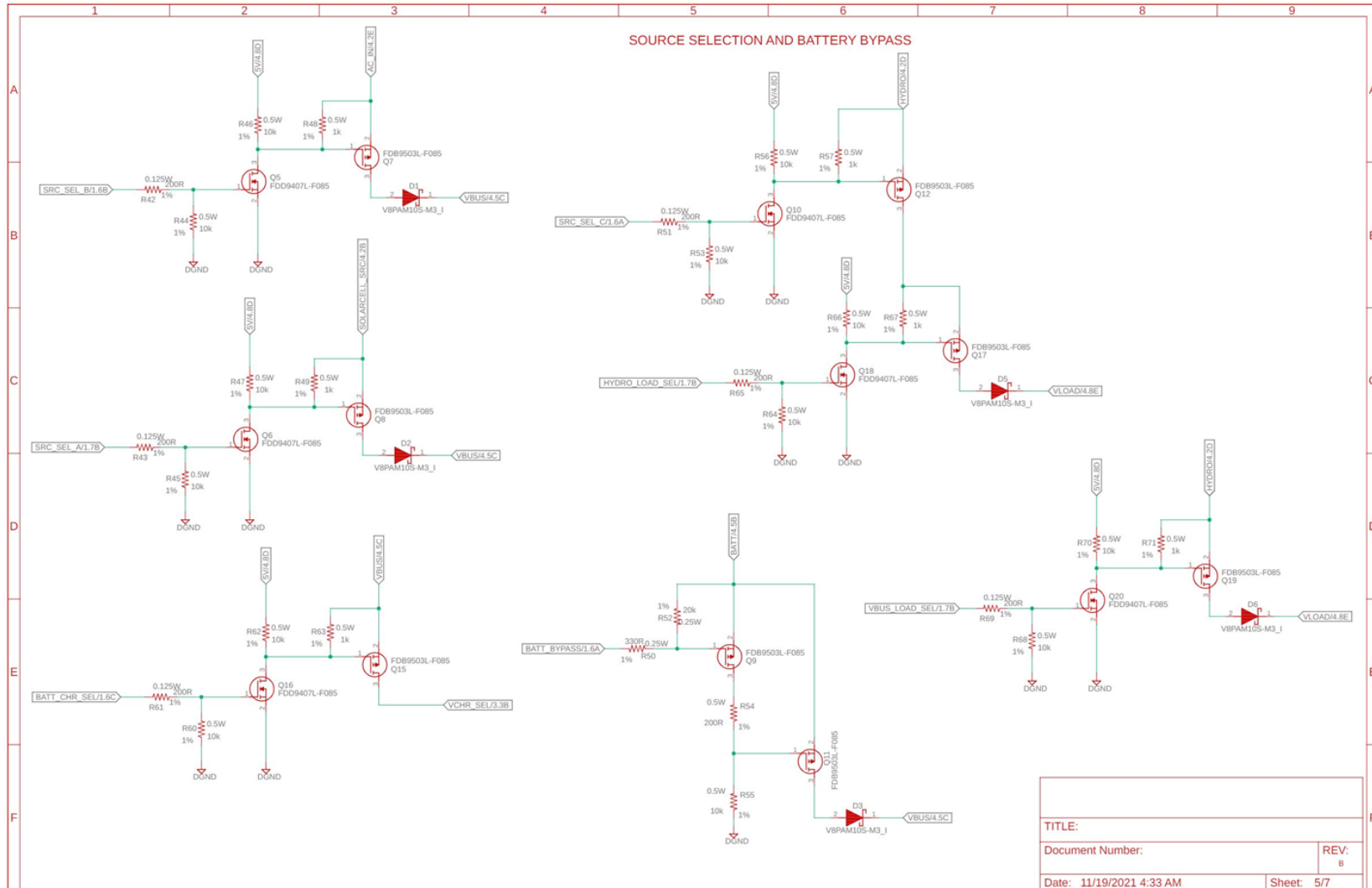

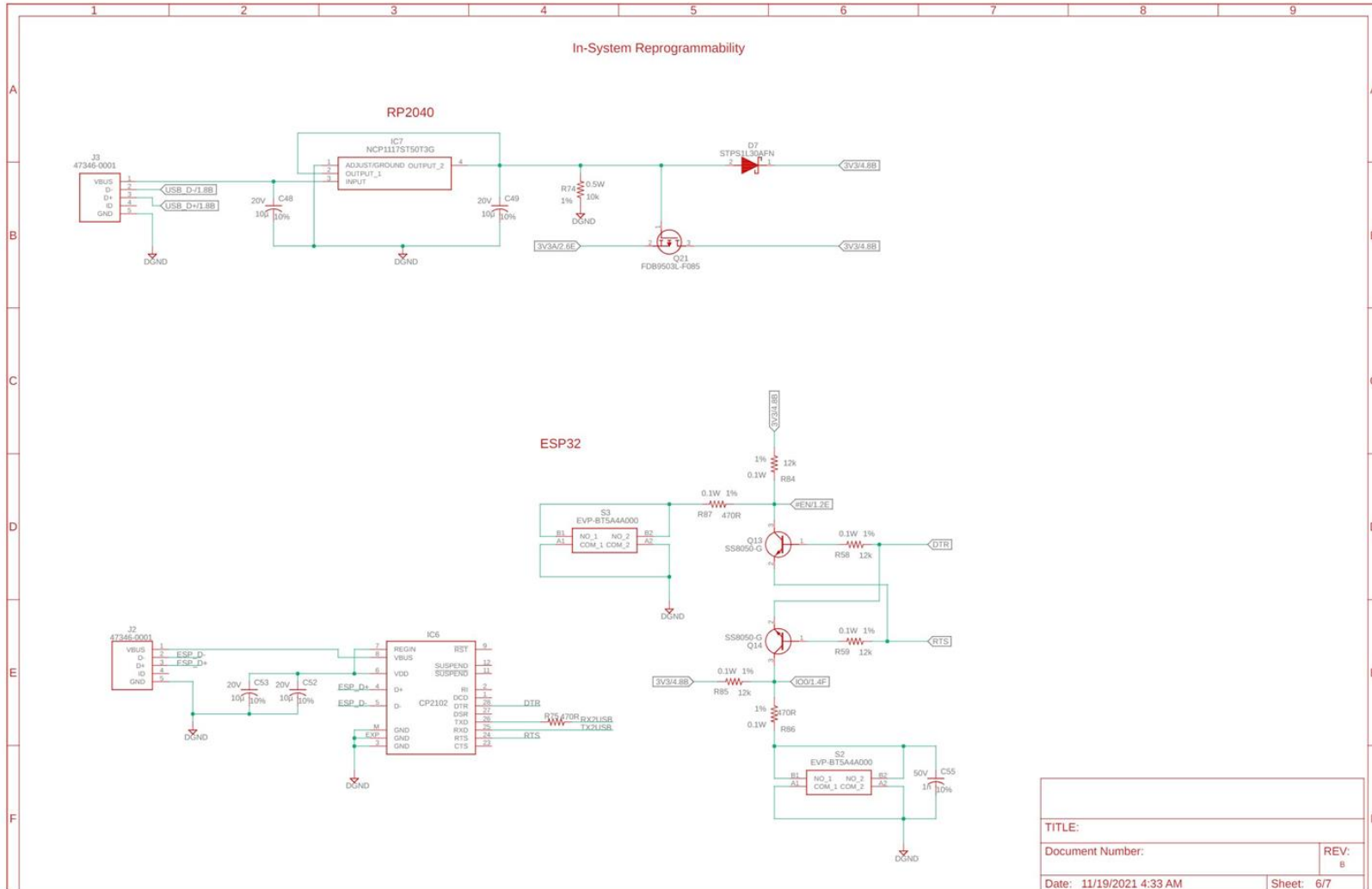

Senior Design II System Schematics

Interface board schematics

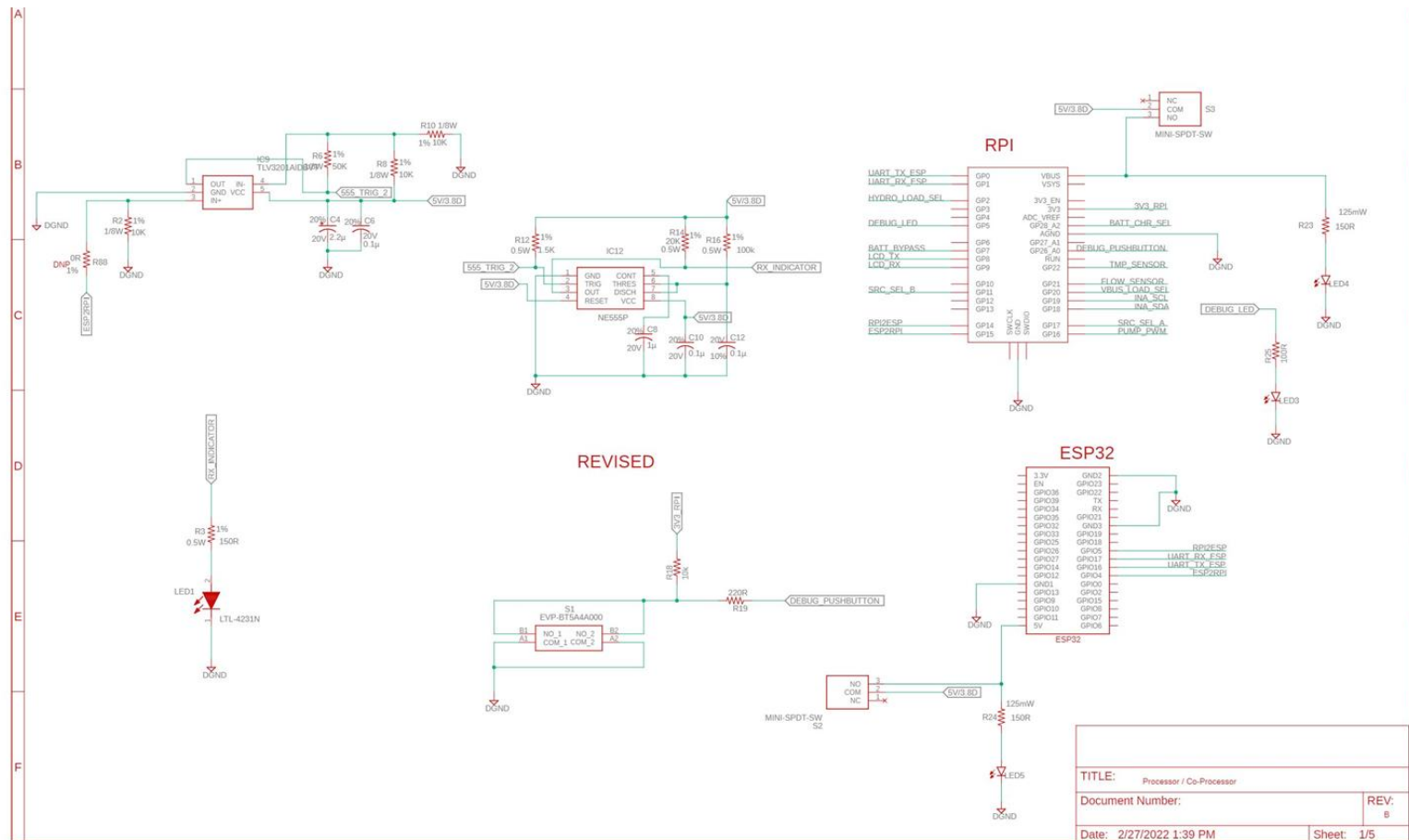

2/27/2022 1:51 PM f=0.95 C:\Users\chris\Documents\EAGLE\projects\SD_V2\INTERFACES.sch (Sheet: 1/5)

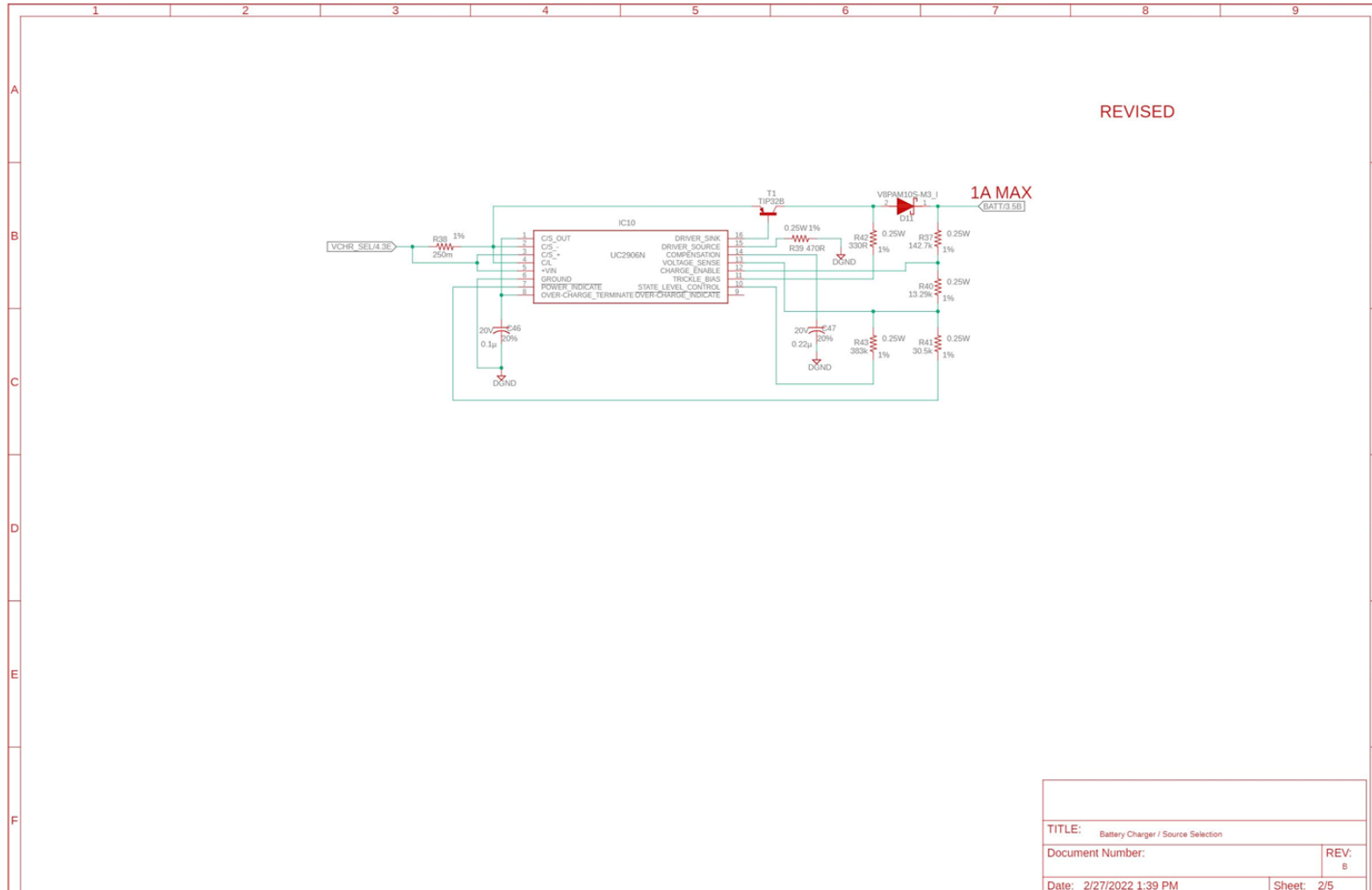

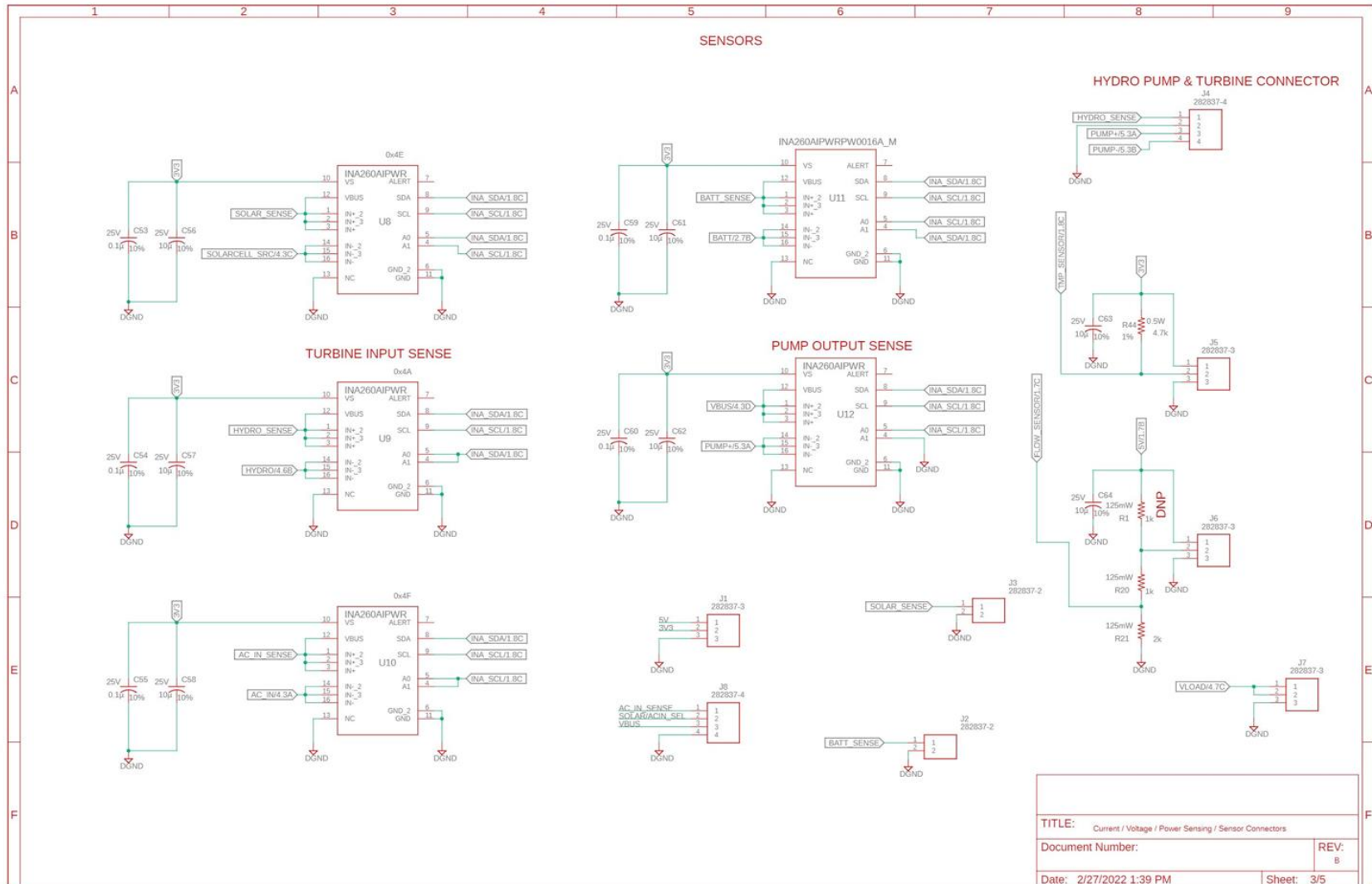

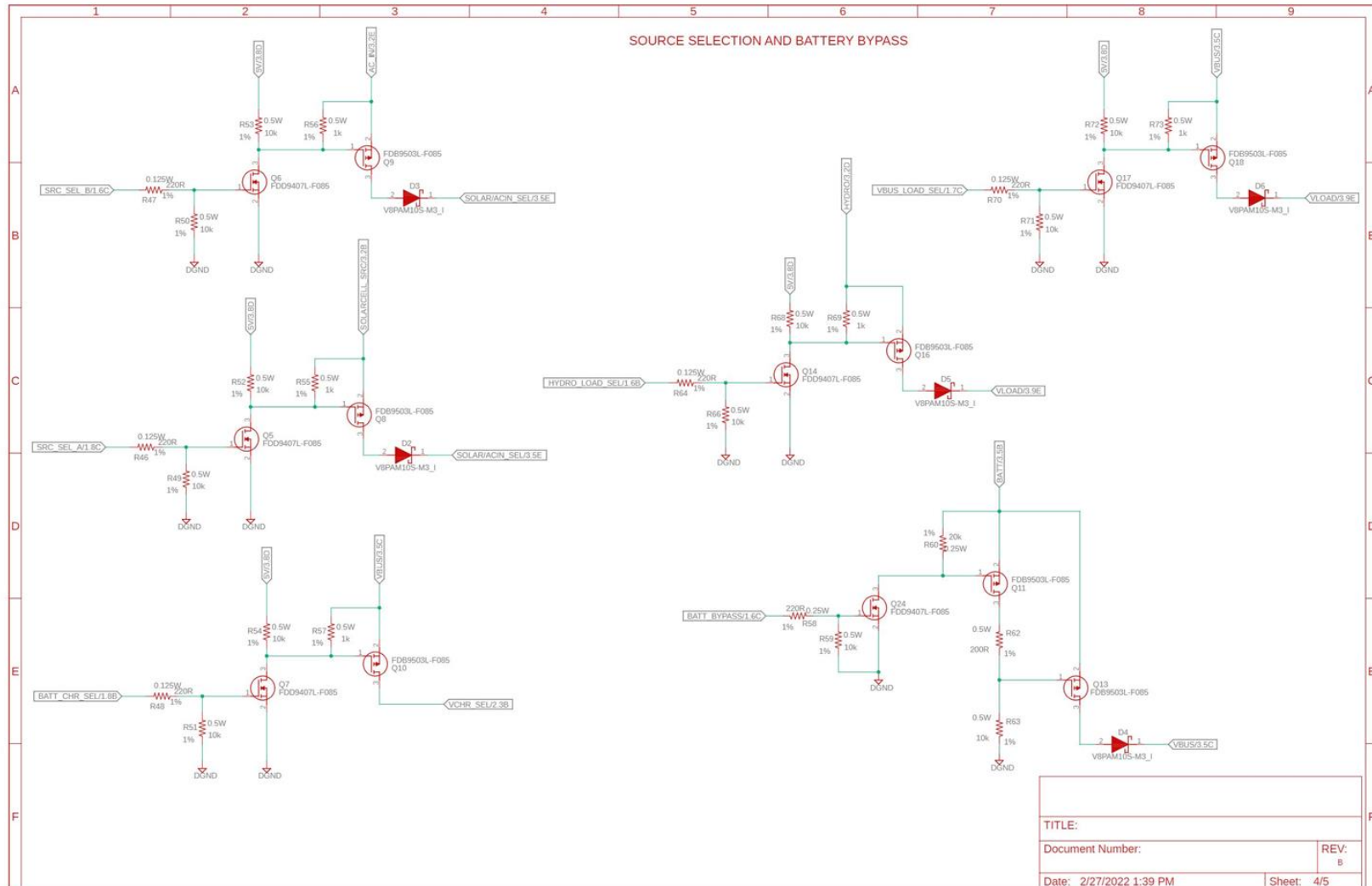

2/27/2022 1:51 PM f=0.95 C:\Users\chris\Documents\EAGLE\projects\SD_V2\INTERFACES.sch (Sheet: 4/5)

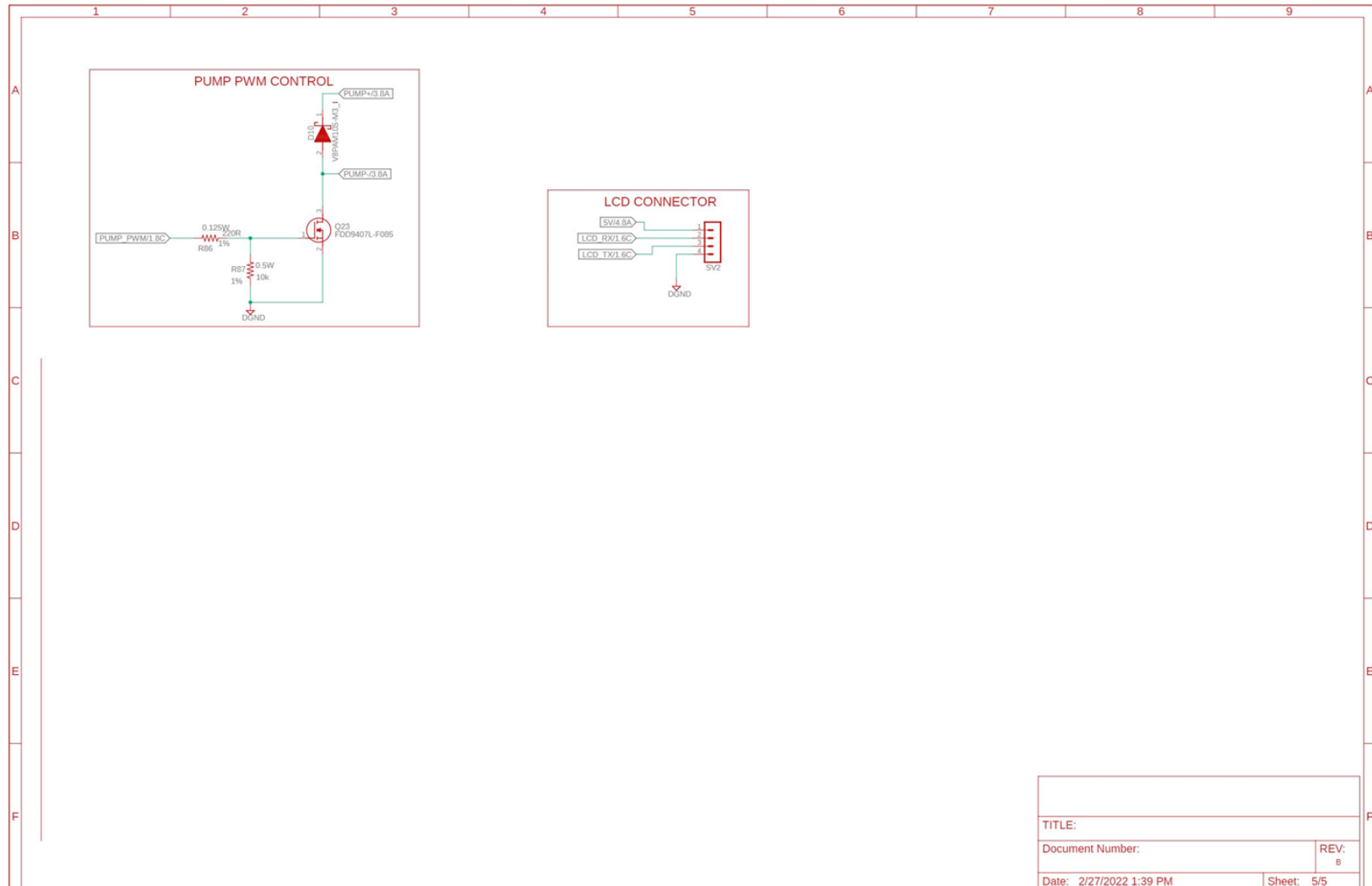

TITLE:	
Document Number:	REV: 8
Date: 2/27/2022 1:39 PM	Sheet: 5/5

Power board schematics

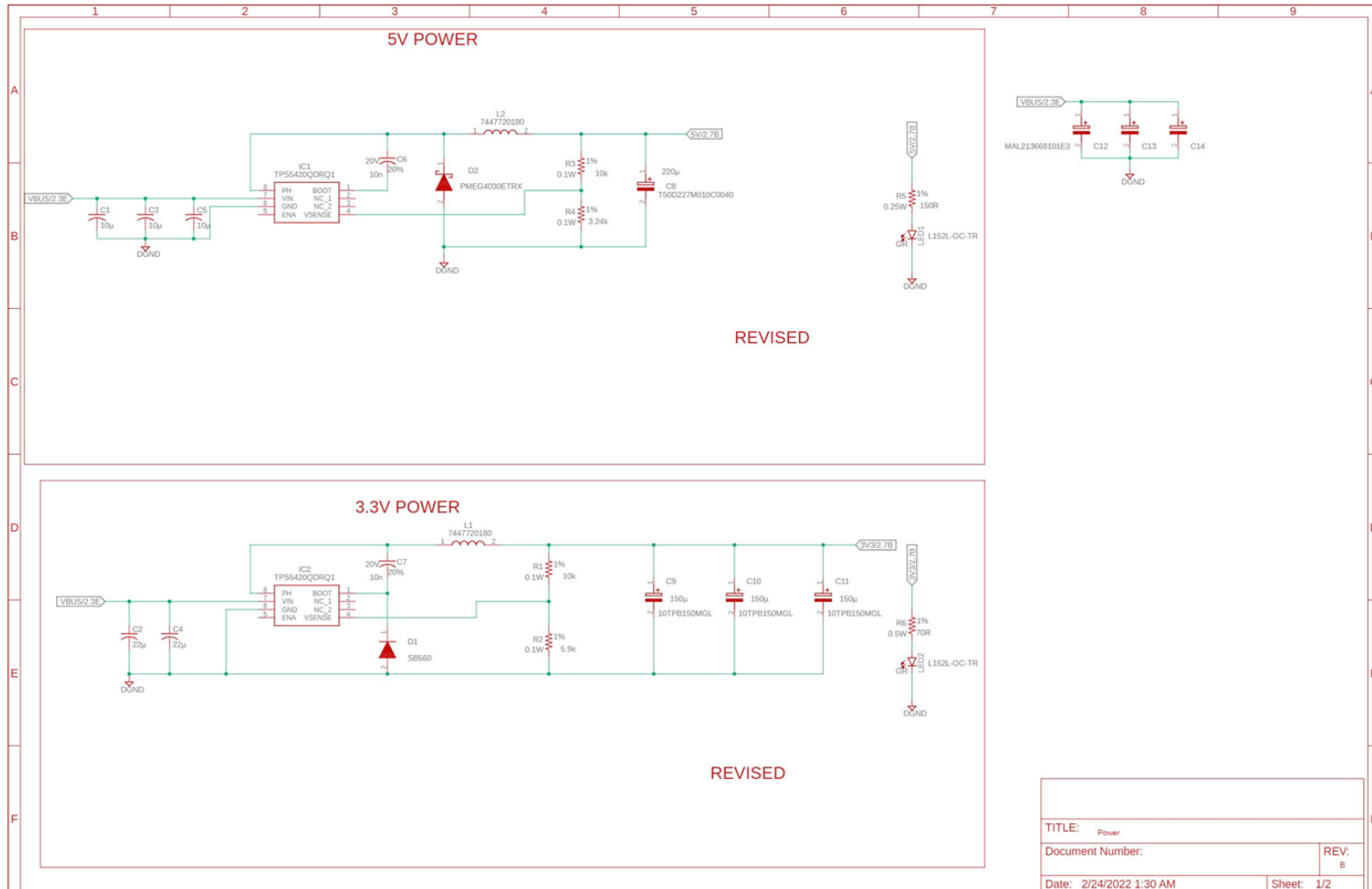

2/27/2022 1:51 PM f=0.95 C:\Users\chris\Documents\EAGLE\projects\SD_V2\POWER STAGES.sch (Sheet: 1/2)

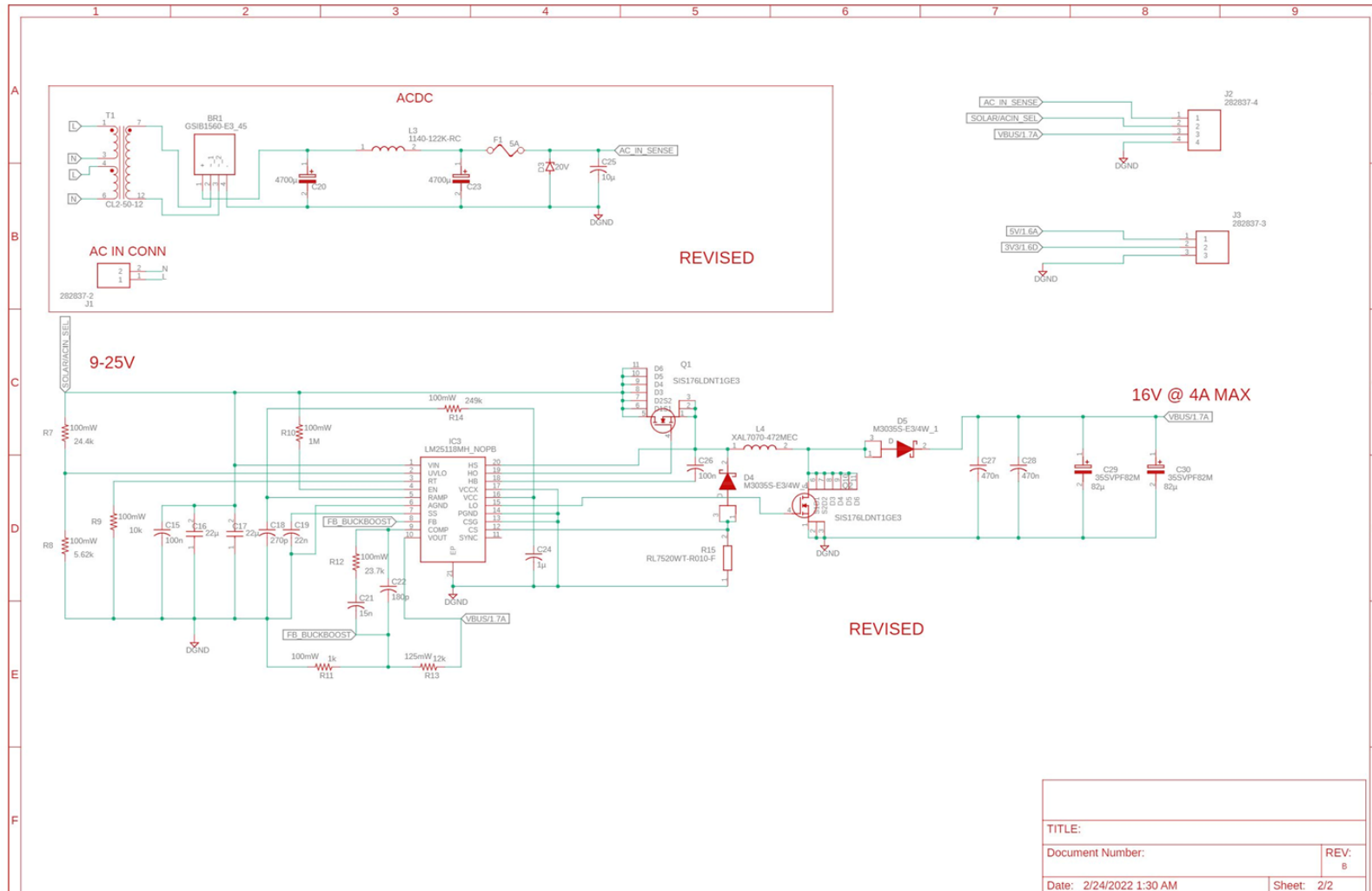

2/27/2022 1:51 PM f=0.95 C:\Users\chris\Documents\EAGLE\projects\SD_V2\POWER STAGES.sch (Sheet: 2/2)