

# *Opto-Smart Pet Feeder*

*Senior Design I*

*Final Document*

*University of Central Florida*

*Department of Electrical Engineering and Computer Science*

*College of Optics and Photonics*

## **Group 9**

Tyler Knight      CREOL

Cassidy Coll      CREOL

Ricky Egawa      Computer Engineering

Jacob Haas      Electrical Engineering

## Table of Contents

1.0	Executive Summary .....	1
2.0	Project Description.....	3
2.1	Project Background.....	3
2.2	Objectives .....	4
2.2.1	Goals.....	4
2.2.2	Motivation.....	4
2.3	Features.....	5
2.3.1	Core Features .....	5
2.3.2	Advanced Features .....	5
2.3.3	Stretch Features.....	5
2.4	Functionality of the Opto-Smart Pet Feeder .....	6
2.4.1	Website / App Functionality .....	7
2.5	Requirement Specifications .....	8
2.6	Marketing and Engineering Requirements .....	9
3.0	Research Related to Project Definition.....	11
3.1	Existing Projects and Products.....	11
3.1.1	Automated Feeder Design .....	11
3.2	Accessories .....	13
3.2.1	Camera System .....	13
3.3	Relevant Technologies .....	14
3.3.2	Fresnel Lens .....	14
3.3.3	Photodiodes.....	15
3.3.4	LED's .....	15
3.3.5	Voltage Regulators.....	15
3.3.6	Microcontrollers.....	18
4.0	Research and Part Selection .....	21
4.1	Bowl and Lid System .....	21
4.1.1	Food Holder .....	21
4.1.1.1	Pet Zone Designer Diner Adjustable Elevated Dog Bowls .....	22
4.1.1.2	IRIS Elevated Dog Bowls - Elevated Dog Feeder .....	23
4.1.1.3	Adjustable Wood Dog Bowl Stand .....	24
4.1.1.4	Gofetch Stainless Steel Pet Food Bowl with Double Diner .....	25

4.1.1.5	Pet Simple Function Gravity Water Dispenser .....	25
4.1.1.6	Bowl System Comparison .....	26
4.1.2	Lid .....	26
4.1.2.1	Lid and Dispenser Motor .....	26
4.1.2.1.1	Motor Driving Chip (Bridgold L293D Chip).....	27
4.1.2.1.2	Stepper Motor (HiLetgo ULN2003 Motor with 5V Drive Board).....	27
4.1.2.2	Three-Dimensional Printing.....	28
4.1.2.2.1	Texas Instruments Innovation Lab at UCF .....	28
4.1.2.2.2	Lockheed Martin IDEA Lab .....	28
4.2	IR LED .....	28
4.2.1	LED Equations.....	29
4.2.2	IR LED Options .....	29
4.2.3	950 nm.....	29
4.2.3.1	NTE30048.....	29
4.2.3.2	SFH 4546-AWBW .....	30
4.2.3.3	MTE9460N5 .....	30
4.2.3.4	950nm IR LED Comparison .....	31
4.2.4	1550 LED.....	32
4.2.4.1	Ultra-Bright NIR, Epoxy- Encased LED, 1550 nm .....	32
4.2.4.2	MTE5115D4 .....	33
4.2.4.4	1550 nm LED Comparison.....	34
4.3	Photodiode .....	34
4.3.1	Photodiode Equations.....	35
4.3.2	950 nm Photodiode Options .....	35
4.3.2.1	S2386-5K.....	36
4.3.2.2	BPV23FL .....	36
4.3.2.3	BPW82.....	37
4.3.2.4	950 nm Photodiode Comparison.....	38
4.3.3	1550 nm Photodiode Options.....	38
4.3.3.1	MTPD1346D-010 .....	39
4.3.3.2	MTPD1346D-030 .....	39
4.3.3.3	MTD6013D3-PD.....	39
4.3.3.4	1550 nm Photodiode Comparison.....	39

4.4	Printed Circuit Board (PCB)	40
4.4.1	Designing a PCB	40
4.4.1.1	Determine what the PCB needs to do	41
4.4.1.2	Pet Collar PCB Battery Selection	41
4.4.1.3	Pet Collar PCB Development Software	42
4.4.1.4	PCB Development Costs	43
4.5	Pet Collar System	43
4.5.1	Pet Collar	43
4.6	Lens System	43
4.6.1	Lens Equations	44
4.6.2	Planoconvex Lens	44
4.6.2.1	Zemax (Optics Studio) Calculations for N-BK7 Lens	45
4.6.2.2	LA1951 – N-BK7 Plano-Convex Lens	46
4.6.3	Fresnel Lens	47
4.6.3.1	Zemax (Optics Studio) Calculations for Fresnel Lens	48
4.6.3.2	FRP125 Lens	50
4.6.3.3	Shappy Thin Fresnel Lens Pocket Size Magnifier Lenses	50
4.6.4	Lens Comparison	50
4.7	Color LEDs	51
4.7.1	Single Color LED	51
4.7.1.1	Red LED Options	52
4.7.1.1.1	C5SMF-RJF-CT0W0BB2 (Red LED)	52
4.7.1.1.2	RL5-R8030 (Red LED)	52
4.7.1.1.3	MV50154 (Red LED)	52
4.7.1.1.4	Red LED Comparison	53
4.7.1.2	Green LED Options	53
4.7.1.2.1	SLR-56MG3F (Green LED)	54
4.7.1.2.2	Super Bright Green 5mm LED (25 pack)	54
4.7.1.2.3	ALMD-CM3E-Y1002 (Blue LED)	54
4.7.1.2.4	Green LED Comparison	54
4.7.1.3	Blue LED Options	55
4.7.1.3.1	C503B-BCS-CV0Z0461	55
4.7.1.3.3	APTD1608QBC/D	55

4.7.1.3.4	Blue LED Comparison.....	55
4.7.2	Multi Color LED.....	56
4.7.2.1	Multicolor LED Options.....	57
4.7.2.2	NTE30159 (Multi-Color LED).....	57
4.7.2.3	WP154A4SUREQBFZGC (Muli-Color LED).....	57
4.7.2.4	FD-5WSRGB-A.....	58
4.7.2.5	Multi-Color LED Comparison.....	58
4.8	Camera System.....	60
4.8.1	Raspberry Pi Camera v2.....	60
4.8.2	BBTO OV5647 Mini Camera Module.....	60
4.8.3	Ximimark USB Camera (LY096).....	61
4.8.5	Camera Comparison.....	62
4.9	Food Dispenser.....	63
4.10	Microcontroller.....	63
4.10.1	Arduino Uno Rev 3.....	64
4.10.2	MSP 430FR6989.....	64
4.11	Microprocessor.....	65
4.11.1	Raspberry Pi 4.....	65
4.12	Coding Language(s).....	66
4.12.1	C.....	66
4.12.2	C++.....	67
4.12.3	C#.....	67
4.12.4	Java.....	67
4.12.5	JavaScript.....	68
4.12.6	Python.....	68
4.12.7	MATLAB.....	68
4.12.8	HTML.....	68
4.12.9	CSS.....	69
4.12.10	Haskell.....	69
4.12.11	R.....	70
4.12.12	PHP.....	70
4.12.13	Coding Language Comparison.....	70
4.13	Programming Language Editing Software.....	73
4.13.1	Atom.....	73

4.13.2	Visual Studio Code.....	73
4.13.3	Repl.it .....	73
4.13.4	Sublime Text.....	74
4.13.5	Notepad++ .....	74
4.13.6	Programming Language Editing Software Comparison.....	74
4.14	OS Distribution software .....	76
4.14.1	Ubuntu .....	76
4.14.2	Debian.....	76
4.14.3	OS Distribution Comparison .....	76
4.15	Web Application Development Software.....	77
4.15.1	React Native.....	77
4.15.2	Reactjs .....	77
4.15.3	Node.js.....	77
4.15.4	Express.....	78
4.16	Mobile Application Development Software.....	78
4.16.1	Flutter .....	78
4.17	Database Management Software.....	79
4.17.1	Firebase.....	79
4.17.2	Heroku .....	79
4.17.3	MongoDB .....	79
4.17.4	MySQL .....	79
4.17.5	Database Management Software Comparison .....	80
4.18	Analog Discovery 2 .....	80
5.0	Design .....	83
5.1	Bowl and Lid System Design .....	84
5.1.1	IR LED Design.....	84
5.1.2	Photodiode Design.....	85
5.1.3	Lid Motor Design.....	85
5.2	PCB Design .....	85
5.2.1	PCB Circuit Simulation.....	86
5.2.2	Eagle PCB Development .....	90
5.2.3	Additional PCB Insights.....	93
5.3	Pet Collar Tag System Design.....	93
5.3.1	LED Design .....	94

5.3.1.1	Color LED Design.....	94
5.4	Camera System Design .....	95
5.5	Food Dispenser Design .....	95
5.6	Microcontroller Design .....	96
5.7	Microprocessor Design .....	97
5.8	Overall Design Schematics .....	98
5.9	System Software Design .....	100
5.10	Web Application Design .....	101
5.11	Mobile Application Design .....	102
6.0	System Testing .....	104
6.1	Optical Demonstration .....	104
6.1.1	Optical Demonstration Components.....	104
6.1.1.1	Camera System .....	104
6.1.1.2	IR LED and Photodiode .....	105
6.1.2	In Class Optical Demonstration .....	105
6.1.2.1	Color LED and Camera System Demonstration.....	105
6.1.2.2	IR LED and Photodiode Optical Demonstration .....	109
6.1.3	Lessons Learned from Optical Demonstration.....	111
6.2	System Modules Testing .....	111
6.2.1	Camera System .....	112
6.2.2	IR LED Detection .....	112
6.2.3	Motor and Dispensing.....	112
6.2.4	Pet Collar System.....	113
7.0	Design Constraints and Standards .....	115
7.1	Standards and other Safety Concerns.....	115
7.1.1	Standards for Working with and around animals.....	115
7.1.2	LED Eye Safety Standards .....	115
7.1.3	Soldering Standards.....	116
7.1.4	Lead Soldering Safety .....	117
7.1.5	Electrical Power Safety Standards (NFPA 1).....	118
7.1.6	PCB Standards (IPC -2221A).....	118
7.1.7	C Language Programming Standards.....	119
7.2	Realistic Design Constraints .....	119
7.2.1	Economic Constraints.....	120

7.2.2	Time Constraints .....	120
7.2.3	Environmental Constraints .....	120
7.2.4	Ethical Constraints .....	120
7.2.5	Sustainability Constraints .....	121
7.2.6	Social Constraints.....	121
7.2.7	Political Constraints .....	122
7.2.8	Health and Safety Constraints.....	122
8.0	Administrative Concerns .....	124
8.1	Schedule.....	124
8.2	Financial Considerations .....	125
9.0	Conclusion.....	127
10.0	Appendix .....	128
10.1	Appendix A: Code.....	128
10.1.1	Optical Demonstration MATLAB Code .....	128
10.2	Appendix B: Works Cited .....	129
10.3	Appendix C: Datasheet Material.....	131



## Table of Figures

Figure 1 Opto-Smart Self Closing Lid Block Diagram .....	6
Figure 2 Opto-Smart Camera and Collar System.....	6
Figure 3 Opto-Smart Lid in Open Position, Activated by Pet .....	7
Figure 4 Opto-Smart Lid in Preparing to Close, No longer Activated by Pet.....	7
Figure 5 Opto-Smart Role Assignment Block Diagram.....	9
Figure 6 Existing Automated Food Dispenser Design .....	11
Figure 7 Existing Automated 5 Meal Feeder Design .....	12
Figure 8 Existing Automatic Feeder Design with Self-Opening/Closing Lid.....	12
Figure 9 Existing LED collar design (Courtesy of puppykisses.com) .....	13
Figure 10 Example of color object tracking (Courtesy of roborealm.com).....	14
Figure 11 Pet Zone Designer Diner Adjustable Elevated Dog Bowl.....	23
Figure 12 IRIS Elevated Dog Bowls - Elevated Dog Feeder .....	23
Figure 13 Adjustable Wood Dog Bowl Top Viewing.....	24
Figure 14 Adjustable Wood Dog Bowl .....	24
Figure 15 Gofetch Stainless Steel Pet Food Bowl with Double Diner.....	25
Figure 16 Pet Simple Function Gravity Water Dispenser .....	25
Figure 17 Motor Controlling Scheme.....	27
Figure 18 HiLetgo Stepper Motor with Drive Board .....	28
Figure 19 SFH 4546-AWBW Spectrum.....	30
Figure 20 MTE9460N5 Spectral Output .....	31
Figure 21 Ultra Bright NIR, Epoxy- Encased LED, 1550 nm Spectrum .....	32
Figure 22 MTE5115D4 Spectrum.....	33
Figure 23 MTE5015-525-IR Spectrum .....	33
Figure 24 S2386-5K Spectral Response .....	36
Figure 25 BPV23FL Spectral Sensitivity .....	37
Figure 26 BPW82 Spectral Sensitivity .....	37
Figure 27: Layout of Plano-Convex Lens.....	45
Figure 28 Spot diagram of plano-convex lens .....	46
Figure 29 Optical path difference of the Planoconvex lens.....	46
Figure 30: LA1951 Lens from ThorLabs .....	47
Figure 31 Fresnel Lens .....	47
Figure 32 Layout of Fresnel Lens .....	48
Figure 33 Spot Diagram of Fresnel Lens.....	49
Figure 34 Point Spread Function.....	49
Figure 35 Shappy Fresnel Lens.....	50
Figure 36 Pinout diagram for a Multi Color LED.....	57
Figure 37: WP154A4SUREQBFZGC Intensity Spectrum.....	58
Figure 38 Raspberry Pi Camera v2 .....	60
Figure 39 OV5647 Mini Camera Module.....	61
Figure 40 Ximimark USB Camera .....	61
Figure 41 Arducam Mini Module OV2640 .....	62
Figure 42 Arduino Uno Rev 3.....	64
Figure 43 MSP 430FR6989 .....	65
Figure 44 Raspberry Pi 4 .....	66

Figure 45 Analog Discovery 2 .....	81
Figure 46 Opto-Smart Pet Bowl IR LED Layout.....	83
Figure 47 Opto-Smart Pet Bowl Photodiode View .....	84
Figure 48 Circuit Schematic for Red LED .....	86
Figure 49 Circuit Schematic for Blue LED .....	86
Figure 50 Circuit Schematic for Green LED .....	87
Figure 51 Circuit Schematic with Values for Red LED .....	88
Figure 52 Circuit Schematic with Values for Blue LED .....	89
Figure 53 Circuit Schematic with Values for Green LED.....	89
Figure 54 Collar PCB Schematic .....	91
Figure 55 Collar PCB Board Layout .....	92
Figure 56 3.3V to 5V Converter Schematic.....	93
Figure 57 Physical Concept of Dispensing Plate .....	95
Figure 58 Arduino Uno and Raspberry Pi 4 Connection through USB (Courtesy of Robotics Back-End) .....	97
Figure 59 Arduino Uno and Raspberry Pi 4 Connection through GPIO Pins (Courtesy of Robotics Back-End).....	97
Figure 60 CanaKit Raspberry Pi 4 4GB Starter PRO Kit.....	98
Figure 61 Opto-Smart Pet Feeder Overall Microcontroller/Pet Collar Schematic .....	99
Figure 62 Raspberry Pi 4 Module Schematics (Courtesy of Raspberry Pi) .....	100
Figure 63 Blue LED Optical Demonstration .....	106
Figure 64 Blue LED with Lens Optical Demonstration .....	106
Figure 65 Red LED Optical Demonstration .....	107
Figure 66 Red LED with Lens Optical Demonstration .....	107
Figure 67 Green LED Optical Demonstration .....	108
Figure 68 Green LED with Lens Optical Demonstration .....	108
Figure 69 Tri-Color LED Optical Demonstration.....	109
Figure 70 IR LED and Photodiode Setup .....	110
Figure 71 IR LED and Photodiode Interruption.....	110
Figure 72 Pet Collar Circuit Test .....	113
Figure 73 Retinal thermal and blue light hazard functions.....	116
Figure 74 Example of clearance between traces on PCB .....	119
Figure 75 Voltage Regulator Circuit from LM 2576 Datasheet (Courtesy of Texas Instruments) .....	131
Figure 76 Adjustable Voltage Regulator Circuit from LM 2576 Datasheet (Courtesy of Texas Instruments) .....	131
Figure 77 MTPD1346D-010 Responsivity Spectrum .....	132
Figure 78 MTPD1346D-030 Responsivity Spectrum .....	132
Figure 79 MTD6013D3-PD Responsivity .....	132
Figure 80 Analog Discovery Two Schematic .....	133

## List of Tables

Table 1 Requirement Specifications.....	8
Table 2 House of Quality diagram .....	10
Table 3 Voltage Regulator Comparison .....	16
Table 4 DC Motor Comparison.....	19
Table 5 MOSFET and Motor Driving Chip Comparison .....	20
Table 6 Dog Feeding Chart.....	22
Table 7 Bowl System Comparison .....	26
Table 8 IR LED Comparison Chart.....	31
Table 9 1550 nm LED Comparison.....	34
Table 10 Photodiode Comparison Chart.....	38
Table 11 1550 nm Photodiode Comparison.....	40
Table 12 Pet Collar PCB Battery Comparison.....	42
Table 13 Lens Comparison .....	51
Table 14 Single Red LED comparison .....	53
Table 15 Green LED Comparison.....	54
Table 16 Blue LED Comparison .....	56
Table 17 Multi Color LED Comparisons .....	59
Table 18 Camera Comparison.....	63
Table 19 Coding Language Comparison .....	71
Table 20 Coding Language Comparison Cont.....	71
Table 21 Coding Language Comparison Cont. 2.....	72
Table 22 Coding Language Comparison Cont. 3.....	72
Table 23 Programming Language Editing Software Comparison .....	75
Table 24 Programming Language Editing Software Comparison Cont.....	75
Table 25 OS Distribution Comparison .....	76
Table 26 Database Management Software Comparison.....	80
Table 27 Limiting Resistor Calculations .....	87
Table 28 Simulated Circuit Values.....	90
Table 29 Component Selection for Collar PCB.....	91
Table 30 Optical Demonstration Color LED Voltages .....	105
Table 31 IR LED and Photodiode Measurements.....	111
Table 32 LED Risk Groups.....	116
Table 33 Solvents and Cleaners .....	117
Table 34 PCB Design Tolerances .....	118
Table 35 Project Milestones.....	124
Table 36 Project Milestones Cont. ....	125
Table 37 Component List (Bill of Materials).....	126

## Table of Equations

Equation 1 Resistor Calculations for Adjustable Voltage Regulator .....	18
Equation 2 LED Voltage Equation.....	29
Equation 3 Photocurrent .....	35
Equation 4 Total Photodiode Current.....	35
Equation 5 Responsivity of a Photodiode.....	35
Equation 6 Lens Makers Equation .....	44
Equation 7 Fresnel Lens Focal Length .....	44
Equation 8 Imaging Equation.....	44
Equation 9 Fresnel Magnification .....	44
Equation 10 Fresnel Loss.....	44
Equation 11 Snell's Law .....	44
Equation 12 Fresnel Lens Equation.....	44

## 1.0 Executive Summary

There are many different types of pet feeders on the market today, but few employ the use of electronics to automatically dispense pet food and most of those products rely on simple timers and can only serve one pet at a time. With many people going back to the office after the COVID-19 pandemic, pets around the world are suffering due to a sudden change to their everyday dietary routine. This product helps eliminate the time, energy, and stress put on the pet owners to feed their pets while they're away from home. Using optics and electrons, the device ensures that the owner's pets are being routinely fed with their correct pet food, without the pet owner being physically present with them. Devices that autonomously feed pets do already exist, however, the use of optics to better ensure that the pets are routinely fed with the proper pet food is what differentiates our product from others that are already on the market today.

The opto-smart pet feeder contains two main and separate parts to properly feed the user's pets. The first main component is the tag on the collar the user's pets must always wear.

The tag on the collar that is initially described functions as a pet specific identification tag for the feeder to read and acknowledge to dispense the pet food for that specific pet. To do this, an LED light that is embedded inside of the tag's water-resistant plastic container emits a specific color of light that the pet feeder can recognize and dispense the correct pet food for that specific pet. This function is especially useful for houses with more than one pet, as the user's second and third pets can wear a collar tag that emits a different color of light than a color that is already in use to properly distinguish and recognize to dispense the pet food for that specific pet accordingly.

The second main component is the autonomous feeder that dispenses the pet's food. The pet feeder contains a compact camera inside the feeding system that monitors and searches the area for the predetermined color of light that is illuminating from the tag on the pet's collar. The user can further decide the specific time of day in which the pet feeder can scan and detect the light coming from the tag on the pet's collar. At that specific time of day predetermined and set by the user, if the selected color of the LED light is illuminating from the tag on the pet's collar and captured on camera for the system to detect, the pet feeder will dispense the appropriately set amount of pet food into the corresponding pet's bowl. Once the food has been dispensed to the pet's bowl, the correct lid will open, allowing the pet to eat its food from the bowl. Infrared LED's surrounding the bowl will constantly be providing the photodiodes as a signal. Once the pet begins eating from the bowl, the photodiodes will be blocked, causing the lid to remain open until the pet completely removes its head from the bowl. Once the detectors regain the signal from the infrared LEDs, a countdown to close the bowl begins. If something does not block the signal within the time the user selects, the lid will properly close automatically.

For the device to properly function and to fully accomplish all tasks mentioned above, several lines of functions and methods in code must be written and implemented into the microcontroller embedded inside the system. The code executed and compiled into the microcontroller must be written well enough for the pet feeder to be able to correctly

identify and distinguish if the selected color of LED light shining from the tag attached to the pet's collar exists in the camera's point of view. Once the correct color of LED light is recognized and acknowledged by the system code in the microcontroller, the dispenser will release the proper pet food for the corresponding pet to eat. The written code must also dispense the accurate amount of food the users decide to feed for that specific pet. The code implemented will allow the user to enter in their exact amount of pet food desired to dispense to the bowl for that specific pet. This will directly correlate with how much food is dispensed, as well as the feeding time.

## **2.0 Project Description**

The Opto-Smart pet feeder is a new type of pet feeder that employs the use of both optics and electronics to automatically feed the users pets when they are not around. Instead of worrying about getting home in time to fill a bowl users can breathe easily knowing their pooches and kittens are not being neglected.

This section contains:

- The background of the project.
- The goals and objectives during the starting design process of the device.
- A motivation discussion section detailing the influences the members had on choosing to work on this project.
- A specification list showing the necessary requirements and core, advanced and stretch features of this project.
- Marketing specifications listed inside of a house of quality diagram.
- Functional diagrams detailing how the optical components of this design will operate.

### **2.1 Project Background**

In households with pet owners must be creative to make sure that their animals are fed every day and that they are keeping a routine schedule. When things come up in life such as working late or an unforeseen event, man's best friend may wind up being neglected. When this happens the pet owners' options are limited, they can either overfeed their animals which may lead to obesity and poor health or pick up an automatic pet feeder.

Another common problem in a household full of multiple pets is ensuring all pets are equally fed. Many times, one pet will rush to the pet bowl to eat their own serving as well as their sibling's dinner.

Many pets also have prescription food or medication. It is very important that the correct pet gets their full dose of medication. It can also be very dangerous if another animal gets hold of that medication. Owners need a way to ensure that they know which pet is eating out of which bowl.

Wet pet food is a healthy solution for many animal owners. One downside to it is that many times, if a pet is not quick to gobble down its food, it will harden. This will in many cases make the picky eater even less inclined to eat the meal. By having a lid on the bowl, the food will stay fresher longer. Making both the pet and owner happier.

An automated pet feeder can take the worry out of feeding a pet by dispensing food at the proper time each day. The only thing that the user must do is to make sure that the dispenser is filled with food when it starts to run low. These devices can take many forms from pre sized individual bowls that can open at a given time, to something more complex with

motors, gears, belts, and Bluetooth functionality. One thing that these designs lack is the ability to feed multiple animals from one device.

In this project we want to take the principal idea of an automated pet feeder and add optical components to it to allow the pet feeder to “know” the difference between pet A, pet B pet C, etc. and then dispense that specific pet food. This will work thanks to a collar tag that the pet will always wear and will emit a specific color of light that the pet feeder can detect. Each pet will be assigned a color by the user that will act as that’s pets’ identity to the feeding system. When the onboard camera detects the correct color at the correct time of day then that pets’ predetermined amount of food is dispensed.

We also want to make sure that other pets do not eat another pet’s food so we will add a lid atop the bowl that can open and close using infrared (IR) LED’s and photodiodes that that best detect IR light built into the pet bowl.

## **2.2 Objectives**

With this project, our core objective is to create a product that feels simple and easy to use to the end user and to give a feeling of luxury through the smart use of the optical elements.

The main objectives of this project will be:

- Take the Stress Out of Feeding Your Pet
- Recognize if a Pet is at its Bowl
- Distinguish the Differences Between Pets

### **2.2.1 Goals**

The goal of the Opto-Smart Pet Feeder is to deliver a high-quality product that is easy for busy pet owners to use even when they’re away from their own home. Optics and Photonics will be used to recognize the pet and to further ensure that the owner’s pets are being properly fed out of their own bowl.

### **2.2.2 Motivation**

In the United States, many families work long hours to make ends meet and sometimes man's best friend is left out of the equation. This can lead to pets' either being underfed from neglect or being overfed by people looking to make up not feeding their pets for days at a time, with both scenarios leading to misery for the pet. This is a key motivating factor in the design of this product. Not only to create something that can have a real-world impact but to also bring malnourished pets a better quality of life.

Pet feeders in general are mostly considered to be small plastic bowls that sit on the floor and the pet owner refills every day. Innovation is slow to come to this field, but it is starting to heat up with all the new “smart” devices flooding the market nowadays competing for space with all the other devices. The difference here is this device can make the difference



between your pet going hungry or not. A device like this could be a step in the right direction for making sure that pets maintain a routine and stay happy. This device is not meant to completely replace the need to care for a pet, but to assist the busy workaholic type of person that sometimes works a double at the office.

This project allows us to demonstrate the knowledge each team member has learned here at the University of Central Florida. As well as showing that each team member can communicate effectively and to work as a team to accomplish a common goal this is a great experience to have before embarking on our future career paths. A mutual love for pets has also helped inspire us to create this project, we all have cats and dogs that would certainly benefit from a product like this. The hurdles and challenges presented in a project like this will be a fantastic experience for the “real world” projects we will encounter down the road. And a device like this one can change a pet's life for the better forever.

## **2.3 Features**

This section contains the core, advanced, and stretch features for the Opto-Smart pet feeder these are the main functions of the project as well as features that may be implemented depending on the many constraints on the project that will be further discussed below.

### **2.3.1 Core Features**

The following core features of the Opto-Smart pet feeder will be major aspects in our design and drive our product.

- Identification collar tag that will open corresponding Opto-smart pet feeder lid
- Camera will identify LED color on pets’ collar
- Self-closing lid once pet walks away from opto-smart pet feeder bowl that will open
- Food is delivered to bowl

### **2.3.2 Advanced Features**

The advanced features outlined below will help elevate our project and show a higher level of design implementation.

- User configurable settings to adjust pet size and time of feedings

### **2.3.3 Stretch Features**

The following stretch features may be implemented if time, budget, and capability enable. These features we would like to achieve if possible.

- Multiple pet bowls to be used by different pets
- Using a webcam for owners to watch pets while owners are out and about

## 2.4 Functionality of the Opto-Smart Pet Feeder

In the normal state, all the photodiodes will be activated by the IR LEDs and the lid will remain closed as shown in Figure 1. In this state, there is no pet at the bowl.

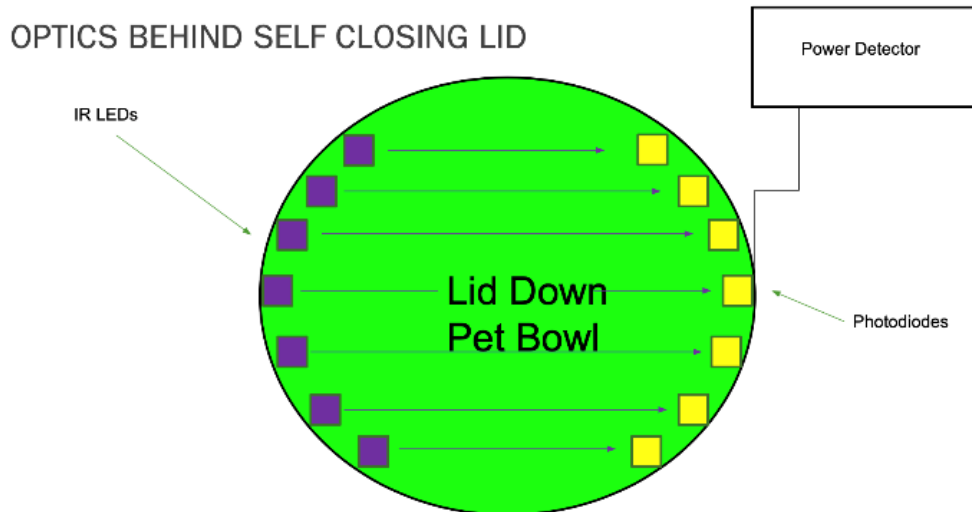

*Figure 1 Opto-Smart Self Closing Lid Block Diagram*

### OPTICS BEHIND CAMERA SYSTEM

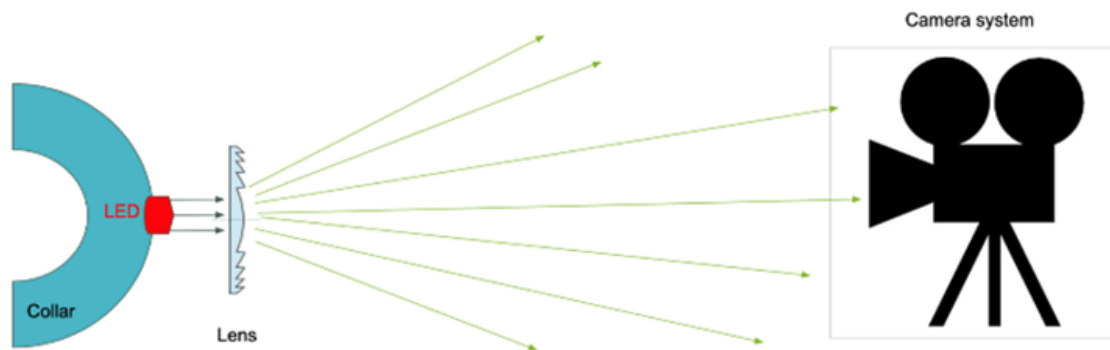

*Figure 2 Opto-Smart Camera and Collar System*

The Opto-Smart pet feeder will be able to detect when the designated pet enters the area. As shown in Figure 2, the collar will have an attached colored LED and Fresnel lens. The Camera system will then be able to pick up which color LED is shining and recognize which pet is entering the area.

Once the camera system detects the pet waiting to get food, the lid will open. While the pet is eating, its head will block the signals of the IR LEDs. This will cause a drop in power detected by the photodiodes. This process is shown in Figure 3.

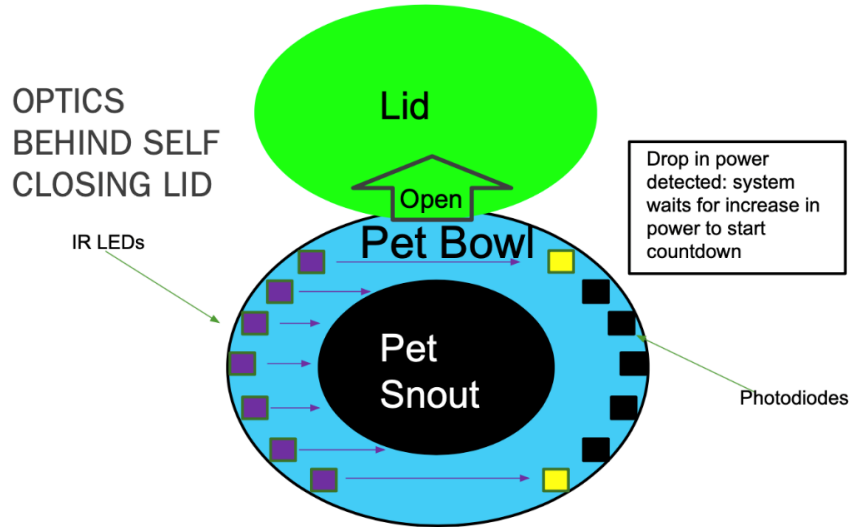

Figure 3 Opto-Smart Lid in Open Position, Activated by Pet

Once the pet is done eating, the photodiodes will gain an increase in power. This will start an internal countdown. If the photodiodes do not go through another drop in power before the timer is done, the lid will close. If the power does drop, the countdown process will repeat. This is highlighted in Figure 4.

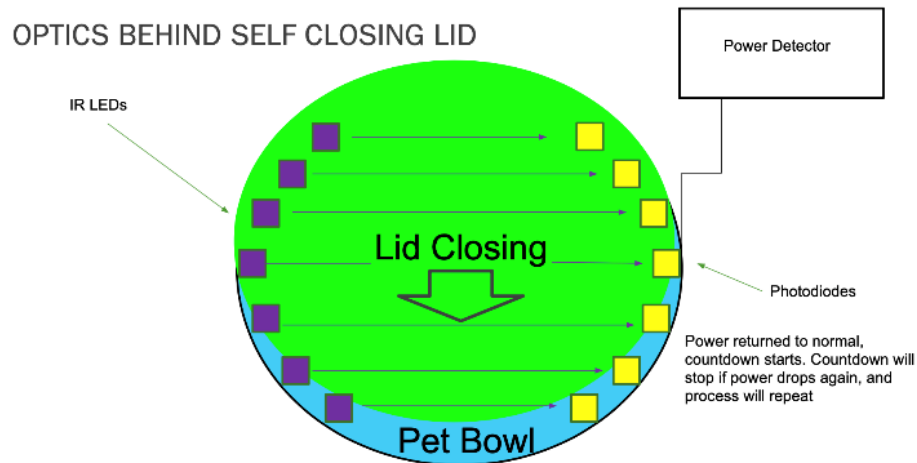

Figure 4 Opto-Smart Lid in Preparing to Close, No longer Activated by Pet

### 2.4.1 Website / App Functionality

The Opto-Smart Pet Feeder offers a webpage, and application functionality where users can remotely communicate with the device via Bluetooth, and Wi-Fi. This allows the user

to remotely utilize the device to its maximum capability when they are on the go and away from their pets.

The Opto-Smart Pet Feeder webpage first introduces the product to the user through its interactive homepage, presenting the product’s features, explaining the product’s goals and objectives, as well as further describing the creation team’s overall motivation and drive answering the question “why are we creating this product?”. After navigating through the homepage, users can direct themselves to either the sign-up page if they are a new user, or to the log-in page if they are a returning user. The new users must go through an online account registration process providing basic personal information such as first name, last name, email, and password to create a secure online account associated with the product for users to access the Opto-Smart Pet Feeder functionality safely on the website.

The online account registration is a very important part of the remote usage on our website, as the creation of the secure account will rightfully eliminate any hazardous and harmful security risks for all our online users. Once the online account registration process has been finished, with the user’s email being verified, the new users and the existing users can now log into their newly created account which will direct them straight into the webpage dashboard that neatly displays all the Opto-Smart Pet Feeder’s functionality for the users to fully control at their leisure.

The application functionality for the users to utilize follows the same usage steps as the webpage, however, this application may be downloaded and used on your smartphone or tablet to make the remote access to the device conveniently accessible on your smartphone or tablet to all users.

## 2.5 Requirement Specifications

The Opto-Smart pet feeder will be able to perform certain requirement specifications as shown below.

*Table 1 Requirement Specifications*

1	Detectable Colors	3
2	Detectable Object Distance	> 5 Feet
3	Power Consumption	< 100 Watts
4	Response Time to LED Detection	< 10 seconds
5	Dispense Time	< 60 seconds
6	Survive Exposure to Mist	> 60 seconds
7	Lid Closure Time after Pet leaves	60 seconds ± 10 seconds
8	Dispensed Food Amount	± 10% of User Inputted Amount

    - Demonstratable specifications

The role assignments for project group are defined in the block diagram below.

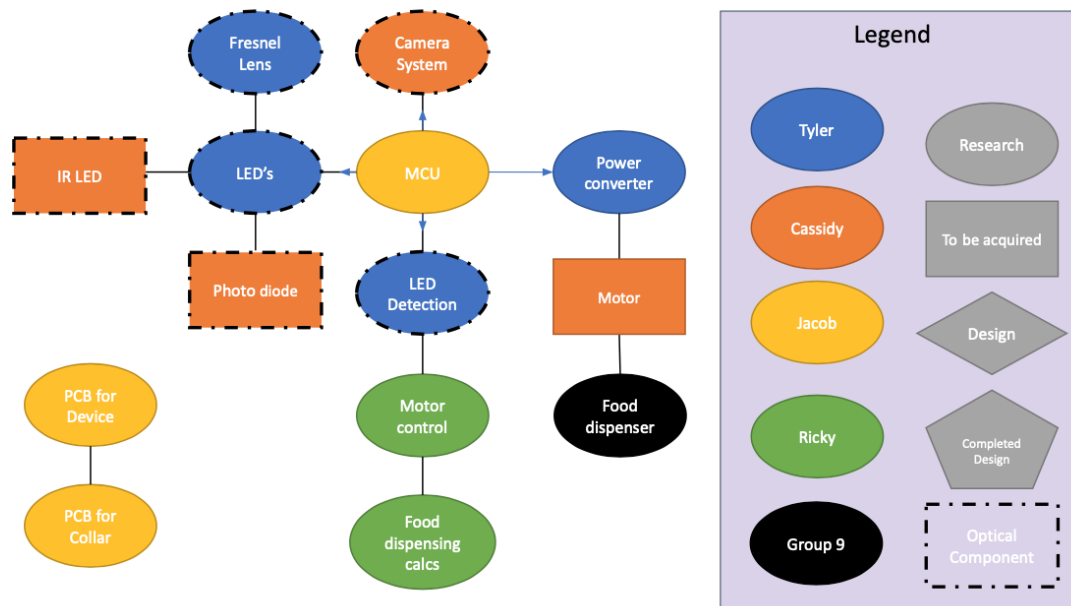

Figure 5 Opto-Smart Role Assignment Block Diagram

This block diagram highlights the aspects of the project design that each group member will be in charge of working on. Additionally, this diagram also details what stage of the design process that each part of the project is at, as well as illustrating whether a certain section of the project relates to any optical hardware.

## 2.6 Marketing and Engineering Requirements

This House of quality diagram shown in Table 2 shows the relationship between the engineering challenges and the customer specifications for the Opto-Smart Pet feeder. Marketing requirements can be considered the size of the market, the type of clientele that you want to target and possible competitors (this is not an aspect of this project).

Since there are many different products like this on the market, keeping certain goals in mind are important to ensure the highest quality product possible for the end user. House of quality tables are important to have during the planning stages of a new project and can keep track of the requirements set forth by the customer and the design team while staying aligned with the marketing requirements of the project. A strong house of quality can help reinforce the goals of the project and pursue what the customer has asked for in the product. Shown below is the house of quality that was created based on the specifications determined previously for our project.

Table 2 House of Quality diagram

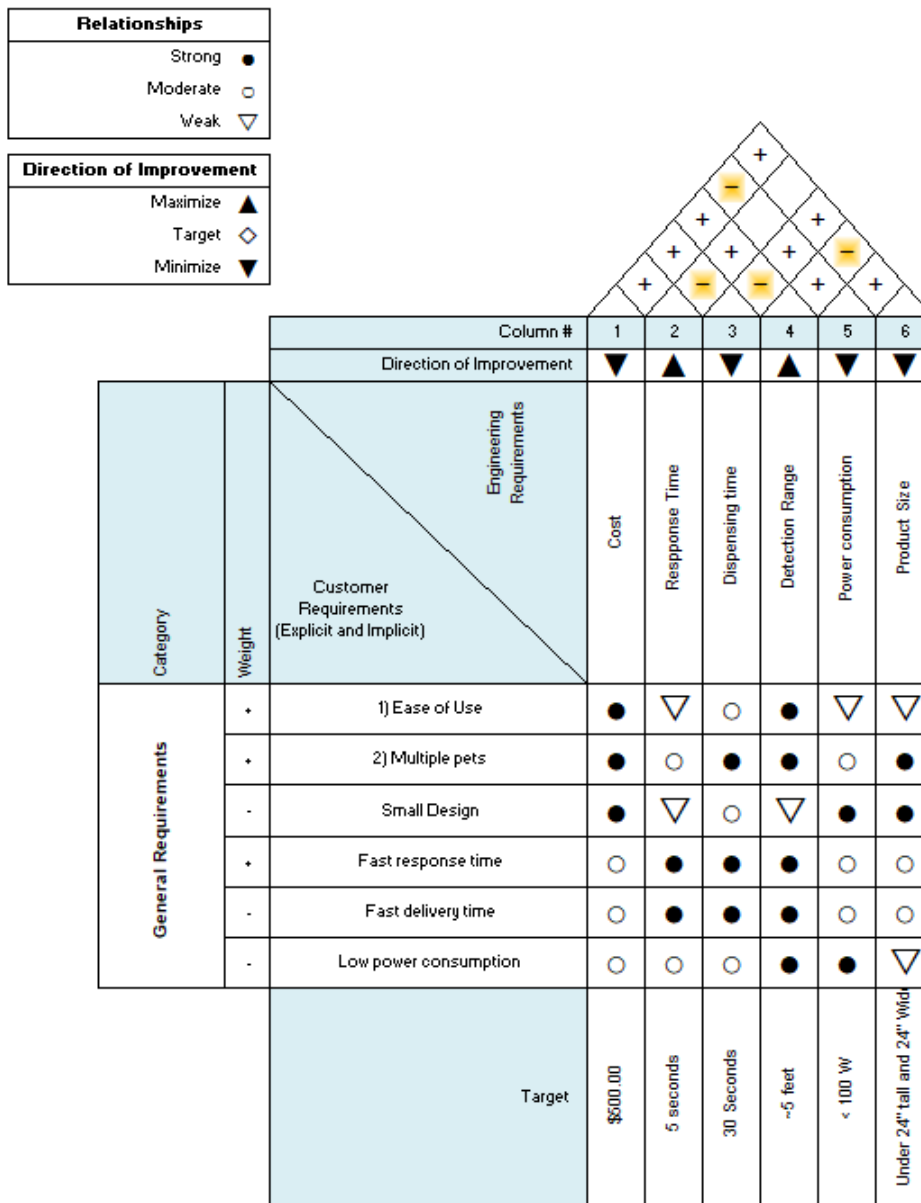

The house of quality diagram pictured above provides the necessary correlations between both the engineering requirements as well the customer requirements. This diagram will help determine how much a customer will benefit from a change in any of our engineering specifications. For example, it is displayed that the cost of the entire project design has a strong correlation to the ease of use of the device. With a larger budget, it is possible to include additional features that allow the user to have a simpler setup and use experience. Since there are certain requirements and constraints that must be met throughout our project design, this diagram highlights the severity at which each specification will affect the user experience and customer needs.

### 3.0 Research Related to Project Definition

This section focuses on related research towards related technologies used with the Opto-Smart Pet feeder. This provides an opportunity to see an overview of the components and how they will function with the device.

The following section contains:

- A list of existing projects and projects pertaining to the development of the Opto-Smart pet feeder.
- An overview of the accessories and features related to the design.
- An overview of the general components used in the design

### 3.1 Existing Projects and Products

Automated pet feeders are not a new idea and there are those that perform either similarly or the same functions. There are existing technologies out there that can dispense food at predetermined times with very different design ideas.

#### 3.1.1 Automated Feeder Design

There are many designs that employ the use of automation in a pet feeder. Because of this we know that it is possible to use motors and electronics to efficiently dispense food reliably each time.



*Figure 6 Existing Automated Food Dispenser Design*

Figure 6 shows a design that can dispense to two separate bowls at the same time. This feeder also allows the user to fill the device with up to 4 liters of food from the top. It uses

gravity and some type of motorized dispenser to deposit food into the detachable bowl. This device runs on both battery and AC Power.

The device also takes advantage of an app to automatically dispense food remotely and to change settings. A voice recording feature is also employed to give your pets a personalized message to encourage them to eat from the feeder. This is very similar to how we would like our dispenser to function. Our design will be an elevated version of this as it will have a lid that will only allow the specific pet to eat from the bowl.



*Figure 7 Existing Automated 5 Meal Feeder Design*

Another design that we saw shown in Figure 7 used a motor that spun a tray around and could hold 5 meals for a pet. Each section holds one cup. Since this is a small feeding size, it is only recommended for extra-small breeds.

The PetSafe Eatwell 5-Meal Automatic Dog & Cat Feeder is an interesting idea since it used a lid to cover up the food and allowed for portion control. And a quick and easy method to schedule meals using a very simple user interface consisting of 6 buttons and a double row liquid crystal display. The bowl automatically rotates to the next opening at a user designed time of day. It uses four D-cell batteries which will last up to a year. This design does not contain a lid that will recognize which pet is eating. It also only holds 5 cups, while ours will hold more than that.



*Figure 8 Existing Automatic Feeder Design with Self-Opening/Closing Lid*



An existing design that includes a mechanical lid is shown in Figure 8. The SureFeed Microchip Small Dog & Cat Feeder can detect the designated pet by either programmable microchip. It works with up to thirty-two pets.

The food must be put into the feeder by the pet owner at each meal. The bowl lid will open when the correct pet is at the bowl and close as they leave. The time the lid takes to close can be adjusted for pet comfort as well as to ensure other pets are not sneaking in.

The system uses four C cell batteries which should last for about six months. It is also only recommended for smaller pets and has a capacity of 1.6 cups. Contrary to our design the food does not automatically dispense the food into the bowl, and it can only be used for small pets.

### 3.2 Accessories

The figure below shows an LED collar tag for a dog that uses a small battery, an LED, and a plastic lens to disperse the light. This accessory is like what we want to create for our device to identify the users' pets.

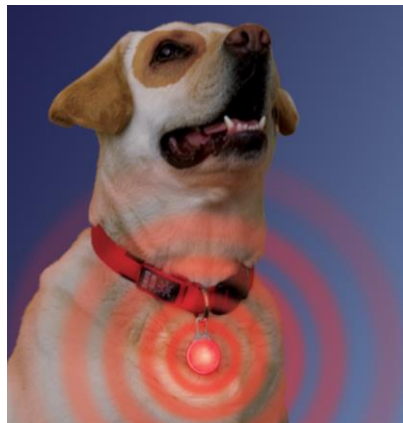

*Figure 9 Existing LED collar design (Courtesy of puppykisses.com)*

#### 3.2.1 Camera System

The camera system that we will use will consist of a compact webcam that will fit inside of the feeder housing and record the environment and look for a specific color. This device will operate just as well in low light environments as environments with regular ambient lighting. This is due to the target being observed emitting its own light source.

The camera will individually scan each row of pixels looking for a specific RGB value that is unique to each collar tag as shown in Figure 10. Technology like this is useful in several different fields. From defense products in planes and missiles to industrial machine lines for packaging and consumer level applications like in toys and smart devices. This is a

useful feature that can operate efficiently with nothing but off the shelf components and code.

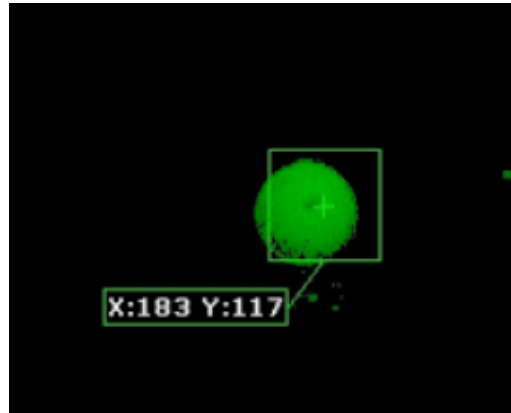

*Figure 10 Example of color object tracking (Courtesy of roboreal.com)*

### **3.3 Relevant Technologies**

In this section, a brief overview of the technologies that will be used with the device is given along with a brief explanation of how these different components operate.

#### **3.3.1 Planoconvex Lens**

A planoconvex lens is a type of simple lens that has one flat side and one curved side. These lenses are great at focusing collimated light into a focused spot at its focal length. These lenses are also superb at dispersing light when the source is at a shorter distance than the focal length.

The benefit to using a planoconvex lens is that it can be used with a large range of wavelengths to diffuse light. The biggest downside to using a lens like this is its size and overall weight. These lenses can become bulky since it is a solid piece of glass. The weight increases when you increase the diameter of the lens or shorten the focal length.

#### **3.3.2 Fresnel Lens**

A Fresnel lens allows for a lens with a large aperture and a short focal length without the weight or the cost of a traditional lens. The Fresnel lens reduces the amount of material required to operate and is more cost effective compared to a simple lens. These lenses can be molded from plastic into a circular disk and then milled with a CNC machine to produce the ridges required to focus light.

This is a boon to this project since it is a low-cost alternative to a simple lens and a lighter lens is a benefit to the pet since they will be wearing it all the time. The downsides to using a Fresnel lens are that the image quality decreases, and they don't work well for systems

that use several different wavelengths. so, this would not be suitable for high quality images but works fine for simple light diffusion.

### **3.3.3 Photodiodes**

Our design integrates photodiodes, a device that converts light into an electrical current. When photons are absorbed into the photodiodes current is produced. This is something that can be used to detect either the presence or the absence of light. These devices can be purchased to operate at specific wavelength and thus operate like a bandpass filter.

The light we are planning to use is 950nm light that is just out of the visible and approaching the IR spectrum of light. Another benefit to this technology is low cost so many can be purchased to increase for this the best device to use would be a photodiode that best operates at or close to 950 nm. This is something vital that we need for this project.

Uses of Photodiodes:

- CD Players
- Medical Devices
- CAT Scanners – X Ray Detection
- IR Remote Controls
- Camera light meters
- Automatic Shutter controls
- Smoke detectors
- Automotive headlight dimmers

From this short list, it is apparent that photodiodes have many advantages that help many of our electronics “see”. Photodiodes are the ideal low-cost option to determine the power output of this project.

### **3.3.4 LED’s**

An LED is a semiconductor light source that can emit light when current flows through it providing a cheap, low power way to provide light to the device. These devices can be found in just about everything from flashing emergency lights to children’s toys.

This is a device that can emit light for long periods of time without burning out like conventional incandescent bulbs or use toxic chemicals like CFL bulbs. This technology is perfect for the use of its previously mentioned advantages without the bulk or the hazards of other light sources.

### **3.3.5 Voltage Regulators**

A voltage regulator can be used to convert a wide range of input voltages into a desired DC output voltage to be used to provide power to components within a circuit. There are

multiple different variations of voltage regulators, including ones built with the use of diodes and separate integrated circuits that can be applied on their own.

Voltage regulators are mostly utilized when there is a voltage input too large to be introduced into the circuit that is being analyzed. In this case, a voltage regulator can be used to convert the large voltage input into a smaller input that is a safe value for most microelectronics.

Linear voltage regulator ICs are usually able to deliver a smaller output voltage from a large input voltage by dissipating the excess power as heat. This is normally an inefficient use of energy since most linear voltage regulators do not have a high efficiency value.

Another type of voltage regulator is a switching voltage regulator which can convert the input voltage into the constant output voltage through the process of temporarily storing energy and then releasing it at the output (at an alternate voltage).

Unlike the linear voltage regulator, the switching voltage regulator has a much higher efficiency value and can also usually accommodate a wider range of voltage inputs. These voltage regulators are perfect fits for applications in microelectronic devices, in which small, constant DC voltages are required to keep these devices safely within their recommended operating range.

To determine what types of regulators could be used in the design of the Opto-Smart Pet Feeder, a comparison between viable voltage regulators will be shown below. This comparison will highlight the major differences between linear and switching regulator as well.

*Table 3 Voltage Regulator Comparison*

<b>Specification</b>	<b>LM2576 (switching)</b>	<b>LM7812 (linear)</b>
<b>Recommended Max Supply Voltage (V)</b>	40	35
<b>Current Limit (A)</b>	7.5	2.4
<b>Recommended Operating Temperature (°C)</b>	-40-125	0-125
<b>Price per part (\$)</b>	2.35	1.96
<b>Efficiency (%)</b>	88	≈ 40 – 48

Some the data from the comparison above was obtained from the datasheets for both respective voltage regulators. It can be shown from the comparison above that the switching voltage regulator would be the better choice overall. Even though there is a slight price increase when selecting the switching regulator, the efficiency values almost double compared to that of the linear voltage regulator.

There would be much less excess power dissipated through the regulator when using a switching regulator, resulting in higher efficiency values that remain almost constant across a wider range of input voltages. Additionally, there are also different types of voltage conversion methods that can be discussed.

A buck converter is a type of DC-to-DC converter that can deliver a lower output voltage than the input provided, and this converter is like what is shown in the table above (for the switching regulator column).

The other type of DC-to-DC converter that may be useful to the design of our project is a buck-boost converter which is able to deliver an output voltage that is either greater or less than what the input voltage was.

If a microcontroller is selected to control certain aspects of the Opto-Smart Pet Feeder, we may have to implement a voltage regulator circuit to deliver the correct constant voltage to the microcontroller (whether it be 12V, 5V, OR 3.3V). Some microcontrollers already can provide this voltage regulation on their own, but some components within our design may need to be powered without any connection to a microcontroller.

A voltage regulator circuit will have to be implemented to be able to convert a 9V – 12V input into a usable voltage input (most likely either 3V, 3.3V, or 5V). Using the switching regulator in Table 3, a sample circuit can be found in the datasheet for the LM2576 regulator (shown in Appendix C). The circuit example from the datasheet be able to be tested and implemented if we plan on using a voltage regulator in our design. This design delivers a constant voltage output of 5V, but an adjustable version can be implemented as well if we need to change the voltage output required by the regulator.

Most microcontrollers will only require an input voltage of 5V. The datasheet for the LM2576 also provides a circuit design for an adjustable version of the voltage regulator circuit shown in Appendix C. This adjustable circuit is also shown in Appendix B.

The adjustable variation of the LM2576 voltage regulator circuit can provide an adjustable output based on the ratio of the two resistors R1 and R2. This circuit can be useful if the voltage input that part of our design needs is not able to be achieved using the standard LM2576 components.

To determine the resistor values needed to produce a desired output voltage, the following equation (provided from TI) can be used.

$$V_{OUT} = V_{REF} \left( 1 + \frac{R_2}{R_1} \right), V_{REF} = 1.23V$$

*Equation 1 Resistor Calculations for Adjustable Voltage Regulator*

### **3.3.6 Microcontrollers**

A microcontroller, also known as an embedded controller, is a small computer on a semiconductor integrated circuit. A microcontroller contains one or more processors along with RAM memory and a programmable input/output peripheral.

There are several different types of microcontrollers available in the market today with different word lengths of 4bit, 8bit, 64bit, and 128bit. A microcontroller is manufactured to automatically control products and devices for them to function properly inside of an embedded system.

Some examples of products and devices that contain a microcontroller are office machines, robots, home appliances, motor vehicles, implantable medical devices, remote controls, power tools, toys, etc.

### **3.3.7 DC Motors**

DC motors are a simple type of motor that deliver a torque that is proportional to the current applied, and the rotational speed of the motor is proportional to the voltage that will be applied to the motor. These motors are very commonly used in projects involving microcontrollers due to the ease at which most microcontrollers can power and interact with the motors using simple software commands

These motors can be used in applications such as camera lenses, actuators, and instrumentation devices. At low speeds, DC motors can mostly provide better performance than their AC motor counterparts. Low-power DC motors have applications in PC hard drives and similar devices such as DVD players.

Additionally, DC motors can be separated into brushed and brushless variants. Brushed DC motors make use of a set of brushes and a commutator which are replaceable parts that can also be worn down with continued use.

Brushless DC motors are operated by switching the driving transistor on and off, instead of using a commutator and brush system. No replaceable brushes are utilized in the brushless design, making them more maintenance free and reliable. We can compare the usefulness of both the brushed and brushless motors to decide which type would work best for the Opto-Smart Pet Feeder. The following table highlights the comparisons between standard brushed and brushless DC motors.

*Table 4 DC Motor Comparison*

<b>Specification</b>	<b>Brushed DC Motor</b>	<b>Brushless DC Motor</b>
<b>Physical Complexity</b>	Low	Moderate
<b>Efficiency</b>	Low	High
<b>Required Maintenance</b>	High	Low
<b>Time/Complexity to Configure</b>	Low	Moderate
<b>Price</b>	Low	Moderate

According to the table above, it is apparent that the brushed DC motor is a cheaper, less complex alternative to a brushless motor. Although the price may be slightly higher and it may be more difficult to setup and configure, the brushless DC motor will most likely better fit the requirements needed for the Opto-Smart Pet Feeder’s functionality.

The greater efficiency and less required maintenance are two positive factors that greatly outweigh any negative factors such as the price and complexity. For the Opto-Smart Pet Feeder to remain up and running without trouble for a longer amount of time, the brushless DC motor will be the better choice.

### **3.3.8 MOSFETS**

Metal-oxide-semiconductor Field-effect transistors (MOSFETs) are elements that are used in embedded circuit design to help implement electronic switches and amplify various electronic signals.

There are two types of MOSFETs, which consist of enhancement and depletion types. Enhancement mode MOSFETs have no conduction when at zero voltage. As the gate voltage is increased to a value greater than the source voltage, a wider channel (for charge carriers to flow) is established.

Enhancement mode MOSFETs act similarly to an open switch, and a gate-to-source voltage is needed to “close the switch” and turn the device on. Depletion mode MOSFETs act oppositely to enhancement mode MOSFETs, in that a gate-to-source voltage is need to “open the switch” and turn the device off.

In contrast to enhancement mode MOSFETs, depletion mode MOSFETs act similarly to a closed switch. MOSFETs are a common choice for low-power motor-driving applications

since they can be safely used at low voltages and currents. Additionally, MOSFETs can also provide relevant function at higher switching frequencies than other higher power options (such as Insulated-gate bipolar transistors).

Below is a comparison on the characteristics and usefulness of using MOSFETs or motor driving chips to control a DC motor.

*Table 5 MOSFET and Motor Driving Chip Comparison*

Specification	MOSFET	Motor Driving Chip
<b>Directional Functionality</b>	Unidirectional motor rotation	Bidirectional motor rotation
<b>Difficulty of Use and Configuration</b>	Moderate	Low
<b>Needs Multiple Additional Components</b>	Yes	No
<b>Price</b>	≤ \$1.20	≈ \$5.00
<b>Chosen Component</b>		

According to the table, the motor driving chip would provide more value to the Opto-Smart Pet Feeder due to its ease of use and ability to drive the motor operation without any additional electronic components. The small price difference between the MOSFETs and the motor driving chip gives yet another reason to pay a slightly increase value to allow for a more efficient design process.



## **4.0 Research and Part Selection**

In this section, the Opto-Smart pet feeder team will discuss the research that was done to ensure that the best parts are selected for our desired resulting product. By doing thorough research on each part we select, we can make sure that our product will function as we expect it to. The best-chosen part from each of these sections will be further outlined below.

The following section contains research for:

- The bowl and lid system
- 950 nm IR LEDs
- 1550 nm IR LEDs
- Photodiodes
- The PCB
- The Pet Collar System
- The Lens System
- The Camera System
- The food dispenser
- The microcontroller
- Coding Language

### **4.1 Bowl and Lid System**

The Opto-Smart pet feeder will be able to be used by all pets, regardless of breed or size. This means the bowl must be the appropriate size to be able to hold enough food to feed a large dog. It also must be able adjust heights to allow the pets to be able to comfortably eat out of their bowl. The system to open and close the lid must also be optimized. The research done to ensure the parts are appropriately decided is described below.

#### **4.1.1 Food Holder**

The bowl capacity must exceed the amount of food needed for a large dog to allow the system to be compatible for all size pets. While the amount of food needed may vary by brand of food, age, and type pet, for example the Purina suggested feeding amounts are specified in Table 6.

For this section, we are only considering the larger sized animals, as smaller pets can still eat out of a large bowl. The bowl must be large enough to hold enough food for extra-large dogs. If the estimated extra-large dog is about 150 lbs., this correlates to about a 5.5 cup feeding amount. There must also be a margin of capacity within the bowl to keep it from overflowing or getting clogged.

*Table 6 Dog Feeding Chart*

<b>Adult Dog Size (lbs)</b>	<b>Dry Food Feeding Amount (Cups)</b>
3 to 12	1/3 to 1
13 to 20	1 to 1/3
21 to 35	1-1/3 to 2
26 to 50	2 to 2-2/3
51 to 75	2-2/3 to 3-1/3
76 to 100	3-1/3 to 4-1/4
100+	4-1/4 plus 1/4 cup for each 10 lbs of body weight over 100 lbs

The bowl will be made of stainless steel as it is the easiest to clean and is also durable and unlikely to break.

The food bowl will be a height that will be comfortable for pets of all heights to enjoy or at the very least be able to be integrated into any size system. Elevated feeding bowls can help aid in digestion and reduces stress on bones.

The system must also be stable and able to handle the weight of the dispensing system. An additional stand or weight balancing addition could possibly be needed and added.

#### **4.1.1.1 Pet Zone Designer Diner Adjustable Elevated Dog Bowls**

The Pet Zone Designer Diner Adjustable Elevated Dog Bowl shown in Figure 11 is sold on Amazon for \$29.95. It has three adjustable heights including 12 inches, 8 inches, and 2.75 inches. This design features enables it to be used for any size dog.

This type of design allows for a puppy to grow with the system. It also has the potential of lasting longer for pet owners as it can be integrated between different pets if needed even if they are different heights. This design includes two bowls for water and food. It easily can be adjusted between heights and is collapsible, so it makes it easier for storage.

The bowls are made from stainless steel which is easier to clean. It is also dishwasher safe and rust resistant. It can hold up to 56 oz. or 7 cups of food. This is in line with the ideal bowl sizing discussed in section 4.1.1. The bowls dimensions are 20 x 10.63 x 6 inches.



*Figure 11 Pet Zone Designer Diner Adjustable Elevated Dog Bowl*

#### **4.1.1.2 IRIS Elevated Dog Bowls - Elevated Dog Feeder**

The IRIS Elevated Dog Bowls Elevated Dog Feeder as shown in Figure 12 is sold for \$24.99 on Amazon, which is cheaper than the bowl in 4.1.1.1. It has two adjustable heights including 12.25 inches and a shorter option for small dogs.

The legs are easily adjusted to change the heights. This is great for growing with your pet but also has less variation than the bowl described in 4.1.1.1. Its dimensions are 21.25 x 11.5 x 12.25 inches. It has two stainless steel bowls that are dishwasher safe. The bowls hold two quarts which is equal to 8 cups. It has an outer rim which helps it to contain spills.



*Figure 12 IRIS Elevated Dog Bowls - Elevated Dog Feeder*

#### 4.1.1.3 Adjustable Wood Dog Bowl Stand

The adjustable wood dog bowl seen below, is on-sale on Amazon for \$9.99. This system is significantly cheaper than the other systems previously described. It has three adjustable heights, 3.9 inches, 7.9 inches, and 11.9 inches for all pet sizes. It is made from solid wood. It includes stainless steel bowls which are dishwasher safe and food grade material.

The wood is shaped in a cute bone shape and the bowls include ears to look like a bear, this adds a design bonus. The dimensions are 16.5 x 9.7 x 13.9 inches. The bowls hold 60 ounces, which is approximately 7.5 cups. The bottom of the bowl includes anti-skid and slip material to help keep the bowl sturdy.



*Figure 13 Adjustable Wood Dog Bowl Top Viewing*

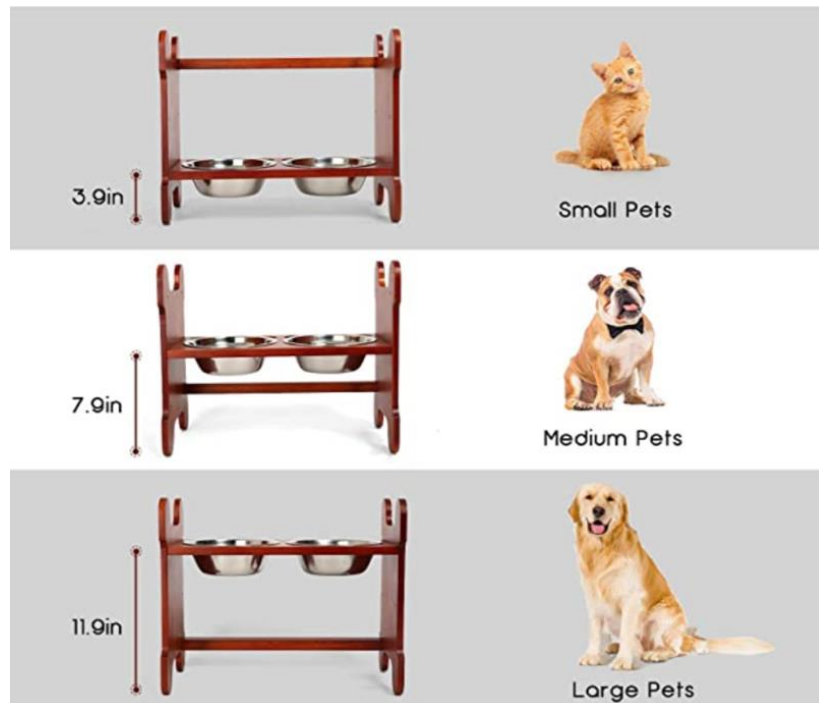

*Figure 14 Adjustable Wood Dog Bowl*

#### 4.1.1.4 Gofetch Stainless Steel Pet Food Bowl with Double Diner

Another choice for our bowl selection is using a more simplistic design as shown in Figure 15. It is sold on Walmart.com for \$6.97. This design just includes two bowls and cannot be adjusted as previous bowl sets. It is 11.5 x 6.38 x 2.66. It would be a size sufficient for small dogs, but it can be used as a proof of concept as the system in the future could be transitioned into a bigger, taller bowl. It also would be simpler in integrating the food dispenser as the food holder could rest on the ground and wouldn't need to be adjusted with the bowl height.



*Figure 15 Gofetch Stainless Steel Pet Food Bowl with Double Diner*

#### 4.1.1.5 Pet Simple Function Gravity Water Dispenser

The Pet Simple Function Gravity Water Dispenser is sold at Ross for \$6.99. This simplistic, cheap bowl system is a good starting point for our project. The plastic jug holds 3.6 quarts / 3.4 liters. Its usual function is to dispense water, but it could also be used by us to hold food. By taking out the part that lets the water out, we can create the motor system. While this system does not allow us to raise the system, it allows us to show a proof of concept. If a pet owner has a need for a bigger system for a larger dog, it can be integrated into that bigger bowl. This water dispenser is shown below in Figure 16.



*Figure 16 Pet Simple Function Gravity Water Dispenser*

#### 4.1.1.6 Bowl System Comparison

In the table below we will compare the bowl systems in order to choose the best component for our design.

*Table 7 Bowl System Comparison*

	<b>Pet Zone Designer Diner Adjustable Elevated Dog Bowls</b>	<b>IRIS Elevated Dog Bowls - Elevated Feeder</b>	<b>Adjustable Wood Dog Bowl Stand</b>	<b>Gofetch Stainless Steel Bowl</b>	<b>Pet Simple Function Gravity Water Dispenser</b>
<b>Adjustable?</b>	Yes	Yes	Yes	No	No
<b>Height</b>	12", 8", & 2.75"	12.25" & 2.25"	3.9", 7.9", & 11.9"	2.66"	0
<b>Size</b>	20" x 10.63" x 6"	21.25" x 11.5" x 12.25"	16.5" x 9.7" x 13.9"	11.5" x 6.38" x 2.66"	-
<b>Bowl Size</b>	7 cups	8 cups	7.5 cups	-	- Jug 3.6 Qt.
<b>Cost</b>	\$29.95	\$24.99	\$9.99	\$6.97	\$6.99
<b>Chosen Component</b>					

We have decided to use the Pet Simple Functional Gravity Water Dispenser as the base of our bowl system. It is the cheapest option and includes a jug which we can use to hold food.

#### 4.1.2 Lid

The lid of the pet bowl will be designed so that it does not interfere with the food dispenser and so that it opens with ease. It will be 3D printed so that we can design the shape to ensure that it fits with the other components in our design.

##### 4.1.2.1 Lid and Dispenser Motor

The lid will need a motor to rotate it open and closed. For the Opto-Smart Pet Feeder, the optimal type of motor will be a stepper motor (a type of brushless DC motor) due to its property of being able to rotate in exact increments (or steps). The Raspberry output is not strong enough to power a motor separately so it will need an external power supply to make sure the board is does not get destroyed while trying to power the motor. Motors are

powered in a direction based off the direction of the current, which means an additional chip must be used. An example of this motor control scheme is shown in Figure 17.

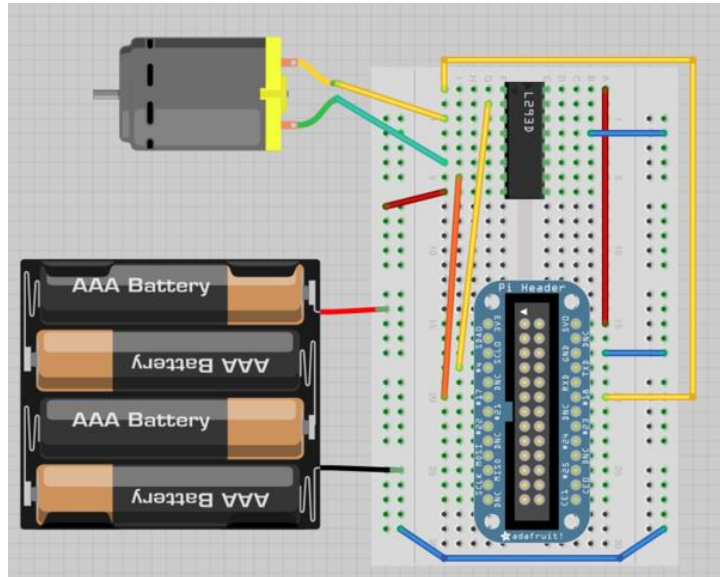

*Figure 17 Motor Controlling Scheme*

(Photo taken of <https://learn.adafruit.com/adafruit-raspberry-pi-lesson-9-controlling-a-dc-motor/lm293d>)

#### **4.1.2.1.1 Motor Driving Chip (Bridgold L293D Chip)**

The Bridgold L293D is a motor driving chip that would suit the needs of controlling both the lid and dispenser motors. A pack of ten is sold on Amazon for \$8.49. The chip can be used to help shift the direction of the current in the motor to change the rotation direction, as well as deliver the adequate power to each motor. It has a single channel output current of 600mA and can be used in applications of up to 5 kHz. The technological comparison from section 3.3.8 made it apparent that using a motor driving chip (such as this one) would be superior in our design over the use of MOSFETs. Another reason the motor driving chip would more seamlessly fit into our device is due to the fact that multiple motors need to be used (for the lid and the dispenser). A single L293D Chip can simultaneously drive two motors without the need for extra hardware.

#### **4.1.2.1.2 Stepper Motor (HiLetgo ULN2003 Motor with 5V Drive Board)**

The HiLetgo ULN2003 4-Phase Stepper Motor (pictured below in Figure 21) is a stepper motor that would work perfectly for the motor capabilities needed for both the lid and the dispenser. Although this stepper motor can be driven by the previously mentioned L293D chip, a 5V drive board is already included with the motor (when a 5-pack is purchased on Amazon for \$13.99). Instead of purchasing a separate driving chip, it would be more efficient for our design to include the drive board that comes default with the motor (as it would be able to supply the necessary controls needed for both motors in our device). This motor and drive board are also compatible with both the Raspberry Pi and the Arduino,



causing the motor setup to involve little difficulty if our design decides to include these microcontrollers/microprocessors.



*Figure 18 HiLetgo Stepper Motor with Drive Board*

#### **4.1.2.2 Three-Dimensional Printing**

To be able to fully customize our design, 3D printers may be used to print the lid. This will allow it to not interfere with the other components of the design. The options for choosing 3D printers are described below.

##### **4.1.2.2.1 Texas Instruments Innovation Lab at UCF**

The Texas Instruments Innovation Lab at UCF has a 3-D printer we could potentially use. The lab is open 10 am – 6 pm Monday – Friday. A flash drive must be provided, and the form should be in a .DXF file. It has a 3D printer that is free to students, but material must be provided. It also has a Universal Laser Cutter that can be used to cut through acrylic and wood.

##### **4.1.2.2.2 Lockheed Martin IDEA Lab**

Lockheed Martin MFC has 3D printers available to employees. It is completely free and they provide the material. The printers are relatively small, so they would not be able to be used for anything too large. They also are busy and operate at a first come first serve basis. It is a little less convenient than the innovation lab but is also slightly cheaper.

## **4.2 IR LED**

This project will use an LED as part of the detector system (not to be confused with the pet collar tag LED system that is discussed in section 5.5.3) that will have a wavelength at or above 950nm. This is just outside of the visible light spectrum and will be completely invisible to the user and the pet.



IR light is completely harmless being emitted from a low powered LED; this is the same type of component found in television remotes. Multiple LED will be positioned inside the perimeter of the dog bowl, forming a semi-circle.

In this section we will research the wavelength as well as the best component for each of those wavelengths.

#### 4.2.1 LED Equations

The below equation will be used to help us calculate key information about LEDs.

$$\frac{V_{in} - V_{LED}}{I_{LED}} = R_s$$

*Equation 2 LED Voltage Equation*

#### 4.2.2 IR LED Options

In this section, we will discuss the difference between different wavelength LEDs as well as the best LED choice to purchase.

#### 4.2.3 950 nm

The Opto-Smart pet bowl team have chosen to research the use an IR LED that will emit light at or around 950 nm. This wavelength was chosen due to its abundant use in many electronic devices such as television remotes, and optical mice.

Many options are readily available to purchase online through sources such as Amazon, Mouser Electronics, Digikey or many other sources. There are many different models being offered that all perform slightly different. The key to this project is to pair the IR LEDs to operate with the photodiodes with the highest efficiency possible.

##### 4.2.3.1 NTE30048

This is an IR LED that emits light at 850 nm, a maximum operating current of 50 mA, a forward voltage of 1.4V, a cost of \$0.71 per unit, and a diameter of 5mm. The cost of this model is appealing since the team can buy several of these LEDs for a small cost. This is the cheapest LED that fits the parameters our team is looking for.

One drawback to this is the LED is the light is emitting at 850 nm, which is much closer to the visible spectrum. This can lead to more noise being picked up in the system and could potentially cause issues detecting objects.

The operating current of this device is also small, this may be a disadvantage depending on how the PCB is designed. The size of this LED is within the specifications of our design.

#### 4.2.3.2 SFH 4546-AWBW

This is an IR LED that emits light at 950 nm, a maximum operating current of 100mA, a forward voltage of 1.4V, a cost of \$0.87 per unit, the diameter of the component is not listed.

This LED fits much closer to the specifications of the project compared to the LED mentioned in 4.2.3. The LED has a viewing angle of 40 degrees. The LED is emitting light at the target wavelength, has a higher operating current, to allow a greater intensity of light to hit the detector (photodiode).

The cost of the component is higher than the LED mentioned in 4.2.3 the cost difference is \$0.16 which is negligible. The figure below shows the Spectrum of the LED.

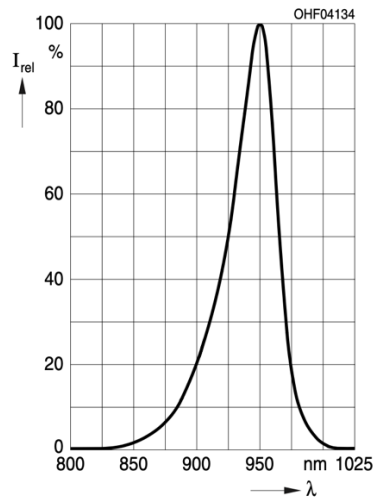

Figure 19 SFH 4546-AWBW Spectrum

#### 4.2.3.3 MTE9460N5

This IR LED emits light at 950 nm, has a maximum operating current of 100mA, a forward voltage of 1.3V, a cost of \$6.21 per unit, the diameter of the device is not listed the LED has a viewing angle of 20 degrees.

This LED is much more expensive than the other LEDs listed in 4.2.3 and 4.2.3.2 the advantage of this device is the narrow viewing angle compared to the other LED's listed this is advantageous due to more light being able to focus into the photodiodes.

The disadvantage of this product is its cost since multiple LEDs need to be purchased for this project. Figure 20 shows the spectral output of the LED.

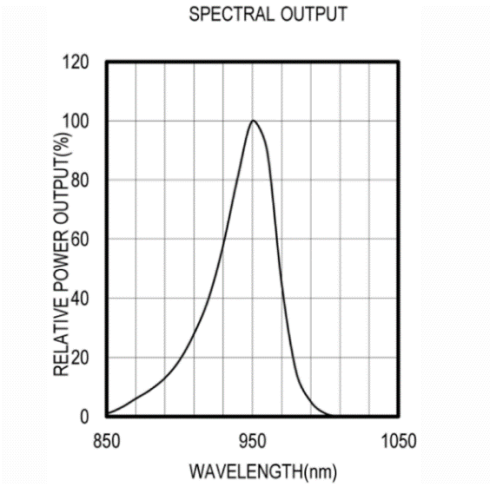

Figure 20 MTE9460N5 Spectral Output

#### 4.2.3.4 950nm IR LED Comparison

As discussed before, the Opto-Smart pet bowl team have chosen to use an IR LED that will emit light at or around 950 nm. This wavelength was chosen due to its abundant use in many electronic devices such as television remotes, and optical mice.

Many options are readily available to purchase online through sources such as Amazon, Mouser Electronics, Digi key or many other sources. There are many different models being offered that all perform slightly different. The key to this project is to pair the IR LEDs to operate with the photodiodes with the highest efficiency possible.

Table 8 IR LED Comparison Chart

	NTE30048	SFH 4546 - AWBW	MTE9460N5
<b>Wavelength (nm)</b>	850	950	950
<b>Operating Current (mA)</b>	50	100	100
<b>Forward Voltage (V)</b>	1.4	1.4	1.3
<b>Viewing Angle (deg)</b>	40	40	20
<b>Cost</b>	\$0.71	\$0.87	\$6.21
<b>Chosen Component</b>			

As stated in Table 8, the clear winner here is the SFH 4546-AWBW. The NTE30048 is the cheapest of the lot but a lot is sacrificed since this LED is emitting 100nm short of what this project requires. This LED also has half the operating current compared to the other LED which would cause the LED to emit less light compared to the other LEDs being considered.

The MTE9460N5 is closer to what we are looking for in an LE since it emits light at 950 nm. It also has a narrow viewing angle that focuses light into a narrower beam which may make power detection easier.

The cost of the device is the main downside since it is several times more expensive than the other two options. This leaves SFH 4546-AWBW as the prime choice to use for this project for its low cost, the wider viewing angle should not affect the quality of the device since multiple LEDs will be used.

#### 4.2.4 1550 LED

A wavelength greater than 1400 nm is generally considered eye safe. This would make it extra safe as the location of the IR LEDs will be somewhat close to the pet's head. The LEDs will also be low power, which will also help with the safety.

##### 4.2.4.1 Ultra-Bright NIR, Epoxy- Encased LED, 1550 nm

Thorlabs sells a 1550 nm Epoxy Encased LED for \$19.91. It operates at a wavelength of 1500 nm. It follows the spectrum shown in Figure 21, which shows it stays above the eye safe level of 1440 nm. It has an operating current of 20 mA and a forward voltage of 1.2 V. It has a viewing angle of 15°.

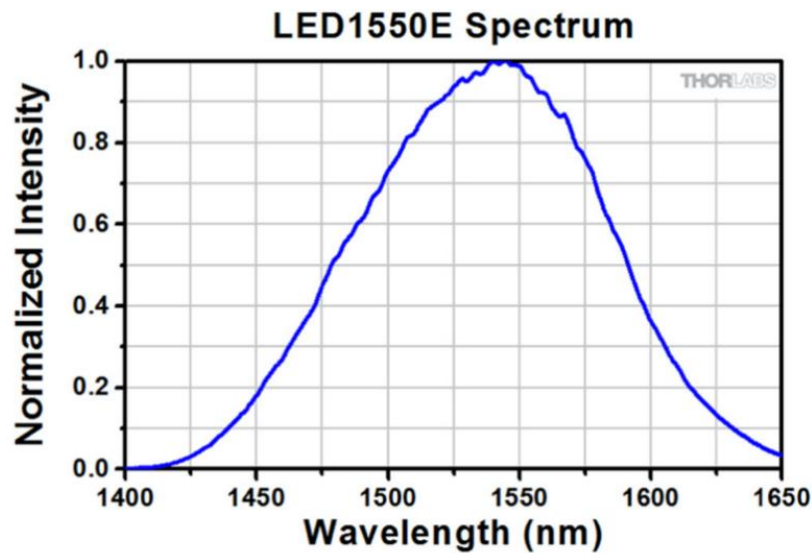

Figure 21 Ultra Bright NIR, Epoxy- Encased LED, 1550 nm Spectrum

#### 4.2.4.2 MTE5115D4

Digi-Key sells the MTE5115D4 LED for \$12.10. It operates at 1550 nm and has a spectrum shown in Figure 22. This LED has a wider spectrum as it goes down to 1200 nm. It also has a very large viewing angle at 240°. It has an operating current of 20 mA and forward voltage of 0.91 V.

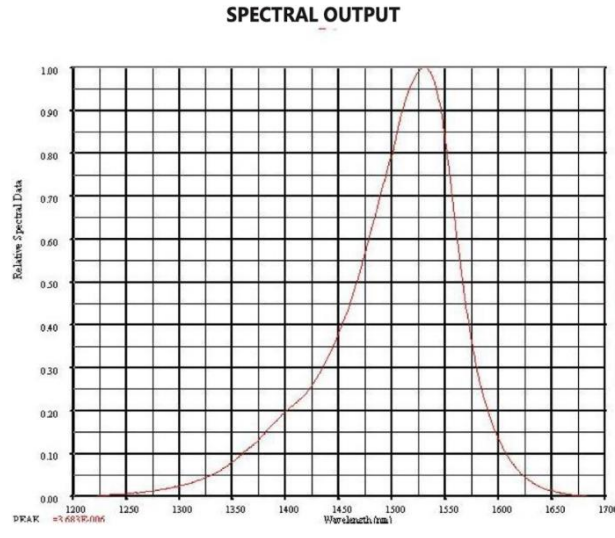

Figure 22 MTE5115D4 Spectrum

#### 4.2.4.3 MTE5015-525-IR

The MTE5015-525-IR LED is sold on Digi-Key for \$16.24. It operates at a wavelength of 1550 nm and has a spectrum as shown below. It also has a wider spectrum as its tappers off towards the 1250 nm range. It has an operating current of 20 mA and a forward voltage of 0.9V. It has a viewing angle of 20°.

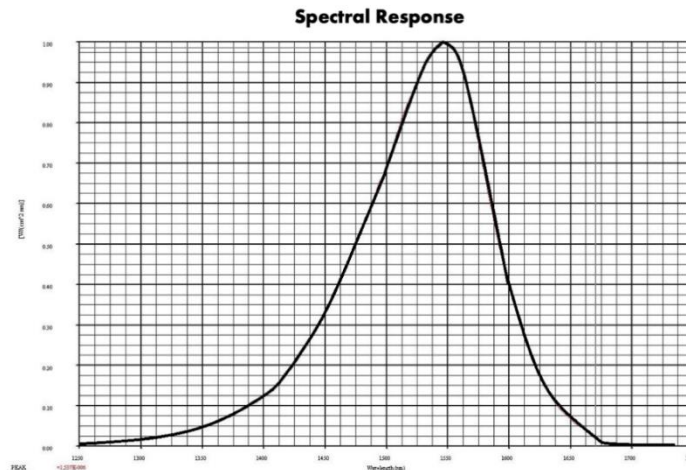

Figure 23 MTE5015-525-IR Spectrum

#### 4.2.4.4 1550 nm LED Comparison

Overall, the 1550 nm LEDs are significantly more expensive than the 950 nm LEDs.

If we were to decide to still use a 1550 nm LED at the higher expense, the best option will be the Ultra Bright NIR, Epoxy- Encased LED, 1550. It had a center wavelength of 1550 nm and its spectrum stayed in the eye safe area as we wished. It also had the narrowest viewing area of 15°. It also is low power as we wished. The only downside is that it was the most expensive 1550 nm LED researched.

*Table 9 1550 nm LED Comparison*

	<b>Ultra-Bright NIR, Epoxy- Encased LED, 1550 nm</b>	<b>MTE5115D 4</b>	<b>MTE5015- 525-IR</b>
<b>Wavelength (nm)</b>	1500 nm (± 50 nm)	1550 nm	1550 nm
<b>Operating Current (mA)</b>	20 mA	20 mA	20 mA
<b>Forward Voltage (V)</b>	1.2 V	0.91 V	0.9 V
<b>Viewing Angle (deg)</b>	15°	240°	20°
<b>Cost</b>	\$19.91	\$12.10	\$16.24
<b>Best Component</b>			

We have decided to use the 950 nm IR LED. It is significantly cheaper for both the LED and the photodiode. It has a much lower operating current, which would make it much more difficult to work for our needs.

We have determined that for our use, the LEDs will both be eye safe. 950 nm is a very common LED wavelength as it is used in many applications such as TV remotes.

#### 4.3 Photodiode

These photodiodes have been specifically chosen to detect light at 950 nm or 1550 nm, which means these photodiodes operate most efficiently at thereabout designed wavelength. This will create a bandpass filter for the device and cut down excess noise from different wavelengths of light.

Since the photodiodes are on one side of the bowl and the LEDs are on the other side this creates a sort of “trip wire’ system that can detect an either the presence or the absence of

an object through a change in voltage. As mentioned in the diagrams in section 2.4, the photodiodes and LEDs are responsible for the lid of the automated pet feeder.

By constantly measuring the difference in voltage the system during feeding time the microcontroller can establish a normal (average) voltage that the system sees when that average drops the system then determines that an object is blocking the light leading to the photodiodes and initiates a flag in the system. Once the voltage raises (returns to average) a countdown is triggered and the lid closes if a voltage drop does not occur. If a voltage drop occurs, then the system restarts, and the countdown stops.

One problem that must be addressed is the height and positioning of the photodiodes and the LEDs inside of the bowl. Too low and the detectors will always be blocked by the pet food, and too high will cause excess noise to be detected by the system and lead to false positives in voltage and cause unintended openings, closures and restarts in the system.

### 4.3.1 Photodiode Equations

For this project, photodiodes will be operated with a reverse bias voltage to increase both the depletion width and the electric field to improve the quantum efficiency and the speed of the response.

The equations listed below are important to this project for determining the photocurrent and the responsivity of a photodiode.

$$I_{ph} = \eta_{overall} \frac{Q P_{opt}}{h f}$$

*Equation 3 Photocurrent*

$$I_{total} = -I_{ph} + I_s \left\{ \exp\left(\frac{qV_{diode}}{k_B T}\right) - 1 \right\}$$

*Equation 4 Total Photodiode Current*

$$R = \frac{I_{ph}}{P_{opt}} \text{ (A/W)}$$

*Equation 5 Responsivity of a Photodiode*

### 4.3.2 950 nm Photodiode Options

As previously discussed, the Optosmart Pet feeder will possibly be using an LED that emits at 950 nm, for this design we need a photodiode to detect the light that is emitted from those LEDs.

What we are looking for in a photodiode is low cost, a low dark current, and a fast response time. Another thing to consider is whether to use a PN photodiode or a PIN photodiode. A PN photodiode would be cheaper than a PIN photodiode but has a poor response time when it is reverse biased. Since we are looking more for a better response than the cheapest option on the market PIN photodiodes will be considered for this project.

#### 4.3.2.1 S2386-5K

This photodiode has a peak sensitivity in the IR spectrum at a wavelength of 960 nm. This wavelength is close to what the Opto-Smart Pet feeder team is looking for in a photodiode. As shown in Figure 24, the spectral response has a wide spectrum. It has a dark current of 5 pA, which can be considered negligible for this product since we are trying to detect around 100 mW of power. Each unit costs \$13.98 per unit. This price is within the budget for the Opto-Smart pet feeder projects budget.

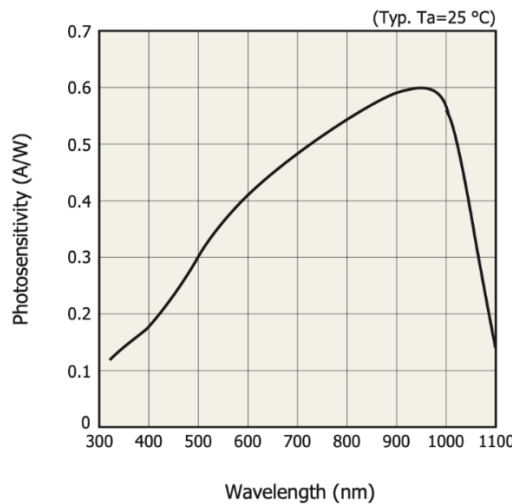

Figure 24 S2386-5K Spectral Response

#### 4.3.2.2 BPV23FL

This photodiode, sold by Mouser Electronics has a peak sensitivity of 950 nm. Figure 24 shows the spectral sensitivity, this wavelength matches what the Opto-Smart Pet Feeder team is looking for in a photodiode.

The photodiode has a dark current of 2nA, a reverse voltage of 60V, a rise time of 70 ns, a fall time of 70ns, a forward current of 50 mA, a forward voltage of 1V and a responsivity of 0.6 A/W. the price per unit is \$1.03 which fits nicely into the budget of the Opto-Smart Pet feeder budget.



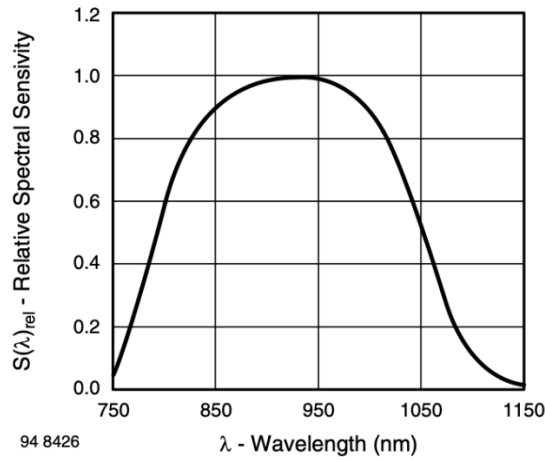

Figure 25 BPV23FL Spectral Sensitivity

#### 4.3.2.3 BPW82

This photodiode, sold by Mouser Electronics has a peak wavelength sensitivity of 950 nm. The spectrum of the photodiode is shown in Figure 26 centers at 950 nm and has a full range from 750 nm and 1150nm. This matches wavelength matches what the Opto-Smart Pet Feeder team is looking for in a photodiode.

This photodiode has a dark current of 2 nA, a reverse voltage of 60V, a rise time of 100ns, a fall time of 100ns, a photocurrent of 45 uA. A forward current, forward voltage and responsivity was not listed on the website. This unit has a price of \$1.07 per unit.

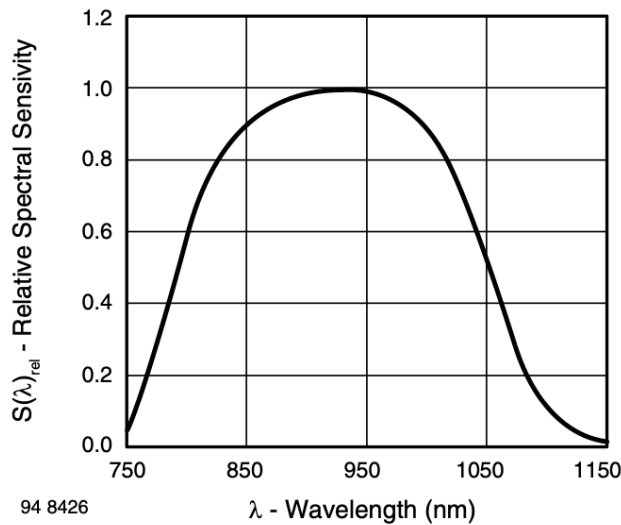

Figure 26 BPW82 Spectral Sensitivity

#### 4.3.2.4 950 nm Photodiode Comparison

In this section, the 950nm photodiodes that were addressed in previous sections are compared and the best photodiode was chosen. The chosen 950nm photodiode was the BPV23FL due to its low cost.

*Table 10 Photodiode Comparison Chart*

	S2386-5K	BPV23FL	BPW82
<b>Peak Wavelength Sensitivity (nm)</b>	950	950	950
<b>Dark Current (nA)</b>	0.005	2	2
<b>Reverse Voltage (V)</b>	-	60	60
<b>Rise Time (ns)</b>	-	70	100
<b>Fall Time (ns)</b>	-	70	100
<b>Photo current (uA)</b>	-	-	45
<b>Responsivity (A/W)</b>	-	0.6	-
<b>Cost (\$)</b>	\$13.98	\$1.03	\$1.07
<b>Chosen Component</b>			

The photodiodes listed here all have clear advantages and disadvantages. The first thing is price, BPV23FL is the cheapest photodiode listed here all while having a better rise and fall time compared to BPW82.

The price between photodiodes 2 and 3 are negligible so BPV23FL is slightly better than BPW82. S2386-5K is the most expensive photodiode with a dark current much smaller than either of the other choices of photodiodes but its peak wavelength sensitivity is 10 nm off from what we are aiming for in this project.

The winner here is BPV23FL for its price and slightly faster rise and fall times compared to the device of similar price.

#### 4.3.3 1550 nm Photodiode Options

As discussed above, our team is researching the use of the 1550 nm LED and photodiode. If we decide to go with the 1550 nm LED, we will need a photodiode that will detect the light emitted.

#### **4.3.3.1 MTPD1346D-010**

The MTPD1346D-010 photodiode is sold by Digi-key for \$26.10. It has a sensitivity wide wavelength range of about 600 nm to 1750 nm. The responsivity spectrum can be seen in Appendix C, and shows that the responsivity at 1550 nm is 0.7 A/W.

This photodiode has a dark current of 100nA, and a reverse voltage of 5V. It also has a photocurrent of 10  $\mu$ A at 1300 nm.

#### **4.3.3.2 MTPD1346D-030**

Mouser sells the MTPD1346D-030 photodiode for \$26.10. It has a wavelength spectrum of 600 nm and 1750 nm. The spectrum shown in Appendix C displays that the photodiode has a very large spectrum but has a responsivity 0.7 A/W at 1550nm. It has a dark current of 100nA and a reverse voltage of 5V. It has a photocurrent of 30  $\mu$ A. The responsivity spectrum referred to for this photodiode in Appendix C.

#### **4.3.3.3 MTD6013D3-PD**

Digi-Key sells the MTD6013D3-PD photodiode for \$17.68. It has a range of 750nm – 1750nm. As shown in Figure 79 C, it has a wide spectrum and a responsivity of 0.46  $\mu$ A at 1600nm. It has a dark wavelength of 100nA and reverse voltage of 2V.

#### **4.3.3.4 1550 nm Photodiode Comparison**

In this section, the 1550nm photodiodes that were addressed in previous sections are compared and the best photodiode was chosen. The chosen 1550nm photodiode was the MTD6013D3-PD due to its low cost. While we picked the best component, it will not be used in our design.

We have decided to go with the 950 nm IR LED, which would need a corresponding 950 nm photodiode. The following table provides the comparison that was done between all the aforementioned 1550nm photodiodes.

As previously stated, the 1550 nm photodiode comparison allowed the selection of the best 1550 nm photodiode for our project design. However, the 950 nm photodiode was what was ultimately chosen due to its cheaper cost and compatibility with the previously chosen components.

Table 11 highlights the main factors that went into choosing the optimal 1550 nm photodiode.

Table 11 1550 nm Photodiode Comparison

	MTPD1346D-010	MTPD1346D-030	MTD6013D3-PD
<b>Peak Wavelength Sensitivity (nm)</b>	1300 nm (600nm ~ 1750nm)	1300 nm (600nm ~ 1750nm)	(750nm – 1750nm)
<b>Dark Current (nA)</b>	100 nA	100 nA	100 nA
<b>Reverse Voltage (V)</b>	5V	5V	2V
<b>Photo current (uA)</b>	10 $\mu$ A (@1300nm)	30 $\mu$ A (@1300nm)	-
<b>Responsivity (A/W)</b>	0.7 (@1550)	0.7 (@1550)	0.46 $\mu$ A (@1600nm)
<b>Cost (\$)</b>	\$26.10	\$26.10	\$17.68
<b>Best Component</b>			

#### 4.4 Printed Circuit Board (PCB)

With modern electronics it is hard to find a device that does not use a printed circuit board (PCB) to assemble electric circuits. A PCB is the bridge between support for the physical components and a connection link for the components.

PCBs can be either very simple with as little as one or two layers of copper or can serve in high density applications with more than 50 layers. A PCB uses pads that are usually made of copper but could be any conductive material (like gold) to link various components together to create an electrical system that allows the various components to work together to serve some type of function.

These traces can either be printed onto a PCB or they can just be wires soldered directly from one component to another. Along with the conductive traces the PCB also serves to insulate the components from one another to prevent unwanted connections or “shorts” using a non-conductive material.

All the unwanted voltage and current must flow somewhere, so the PCB must also have a ground to protect against high voltage through the system and eliminate excess noise. For this project, several different PCBs may have to be created to serve different purposes.

##### 4.4.1 Designing a PCB

A quality PCB is crucial for the OptoSmart Pet Feeder not only for peak performance but to ensure a long lifetime for the product. It is paramount that the OptoSmart Pet Feeder

team designs a quality, long lasting PCB. While each PCB design can differ wildly, many of the approaches to the design remain the same.

By following this methodology each PCB that is designed and implemented into the design meets the same quality standards that the end user can know and trust that their product will work every time. The techniques listed below gives a brief overview of recommended steps and techniques to follow when designing a PCB.

#### **4.4.1.1 Determine what the PCB needs to do**

The first step to this process may seem intuitive but it is important to understand what you are looking for out of your PCB design. Create a list of things that need to happen to achieve your desired effect and create a table of how many components are being included in the design. Also consider the size of the components you are thinking of using and where they should be placed on the board. Several large components, such as large electrolytic capacitors or a transformer should be spaced out wherever possible. This is a good time to see the specifications of those components.

In the case of the OptoSmart Pet Feeder, one PCB that must be created is the PCB that controls the functionality of the pet collar (the system that activates and powers the LED attached to the pet collar). This PCB will need to include a portable power source (battery) and a way for that battery to deliver a current to the LED attached to the PCB whenever the battery is switched on. The size of this PCB will also need to be small enough to reduce annoyance to the pet wearing the collar (approximately less than 5 square inches in area).

#### **4.4.1.2 Pet Collar PCB Battery Selection**

The PCB to be implemented within the pet collar will be a relatively small circuit board that is able to deliver power to an LED so that the chosen camera module can detect the color emitted from the LED. This PCB should be no larger than 5 square inches in order to easily and securely fit within the casing that will be constructed for the pet collar. With this constraint in mind, the battery size must also be small enough to fit on the PCB without causing and conflicts with the surrounding casing.

To send power to the LED through the PCB a small battery must be selected that is able to deliver the correct amount of voltage and current without weighing the collar down too much. Normal AA or AAA batteries will most likely be too large to comfortably fit into the pet collar, so coin batteries will be the desired battery to power the LED on the collar. Since the LEDs that will be used for the collar do not exceed a 3V forward voltage, three different compact sized 3V batteries can be compared. Even though the LED forward voltage is normally close to 3V, multiple batteries can be combined as long as there is a resistor placed in series with the LED in order to limit the current flow to an acceptable amount. The choices for a viable battery are shown in the table below:

Table 12 Pet Collar PCB Battery Comparison

Model name	CR2025	CR2032	CR1632
Dimensions (D x H) in mm	20 x 2.5	20 x 3.2	16 x 3.2
Weight (g)	2.6	3	1.8
Capacity (mAh)	≈ 170	≈ 235	≈ 130
Cost	≈ 1.3	≈ 1.5	≈ 1.4
<b>Chosen Component</b>			

According to the table above it is apparent that the only major differences between these batteries is size and capacity. Since only a single battery will be used to power the LED within the collar’s PCB, the price differences are almost negligible (the prices can also fluctuate depending on the quantity ordered and time/location of purchase). In addition, all three batteries contain capacities that would be able to keep the low power LED on for at least multiple months at a time.

The most important criteria in this case would be the size and weight of the battery since a lightweight design is the main goal (and most beneficial to the pet that will be wearing the collar). The CR1632 seems to be the most optimal choice when it comes to both size and weight, since this battery has the smallest diameter while weighing almost half that of the CR2032.

#### 4.4.1.3 Pet Collar PCB Development Software

The software that we are planning to use to design the PCB for the pet collar will be Autodesk EAGLE, since it is a fully functional software that allows both schematic and PCB creation and is what most of the team members are comfortable using (from prior class experience).

The EAGLE software will allow our team to develop a PCB using the components (LED and battery) that were selected to be most optimal for the development of the pet collar. This software will be used to import the exact parts chosen for the battery and LED selection and connect them virtual with the schematic creator.

A PCB board layout will then be developed from the schematic and proper trace routing and grounding protocols will be followed before sending the final PCB design to be

physically implemented. There will be no additional cost required for access to EAGLE, since the education edition is available to students at no extra fee.

#### **4.4.1.4 PCB Development Costs**

To have the PCB fabricated from the design that will be developed using EAGLE, we will use an online PCB fabrication company that is able to manufacture and deliver multiple copies of a custom PCB in a short amount of time. An approximate cost for 5 units of a PCB at a size of less than 5 square inches (127 square millimeters) seems to be between \$20-\$35 with shipping included.

Once the design of the pet collar PCB schematic is complete and the components have been tested using a breadboard (to ensure compatibility and functionality) the PCB cost should ideally be a one-time fee that results in a PCB that will be able to be easily implemented into our design of the pet collar.

### **4.5 Pet Collar System**

The pet collar will consist of a normal collar. Our design will be able to be integrated into any size collar so that pets of all sizes can use it. Each pet in the household will need to have a different color LED.

The lens will disperse the light in order to allow the camera to be able to more easily identify the LED color. The following sections will describe the research done to decide between using one collar with a tri-colored LED, or three different collars each consisting of one color. It will also describe the research done on which Fresnel lens to choose.

#### **4.5.1 Pet Collar**

To save money we will use a pet collar that we have at home. The size of the pet collar does not matter as the functionality will be able to be integrated into any size dog collar. The device that we will be creating is a tag for the pet collar which is explained in detail below.

### **4.6 Lens System**

For the Opto-Smart Pet Feeder, we would like to design a lens that will help enhance the LED light that will be on the collar. This will allow us to increase the efficiency of the LEDs while not having to add more LEDs to the system.

A lens will also allow the collar tag to be seen by the feeder's camera system at a greater distance since the light from the LED is being dispersed. The lens will also act as protection for the internal components of the system so the lens chosen must integrate well with the collar tag. In the following sections, we will show the research put into finding the perfect lens for the Opto-Smart Pet Feeder.

### 4.6.1 Lens Equations

This section covers the equations used for finding the perfect lens for the collar tag of the Opto-Smart Pet Feeder.

$$P = \frac{n_{Lens} - n_o}{n_o} \left( \frac{1}{R_1} - \frac{1}{R_2} \right)$$

*Equation 6 Lens Makers Equation*

$$P = \frac{1}{f}$$

*Equation 7 Fresnel Lens Focal Length*

$$\frac{1}{\text{Object Distance}} + \frac{1}{\text{Image Distance}} = \frac{1}{f}$$

*Equation 8 Imaging Equation*

$$M = \frac{-\text{Image Distance}}{\text{Object Distance}}$$

*Equation 9 Fresnel Magnification*

$$\frac{I_R}{I_L} = R = \left( \frac{n_2 - n_1}{n_2 + n_1} \right)$$

*Equation 10 Fresnel Loss*

$$n_1 \sin \theta_1 = n_2 \sin \theta_2$$

*Equation 11 Snell's Law*

$$\frac{d\alpha(x)}{dx} = \frac{2cx}{1 + \sqrt{1 - c^2(k+1)x^2}} + \frac{c^3x^3}{(1 + \sqrt{1 - c^2(k+1)x^2})^2 \sqrt{1 - c^2(k+1)x^2}} + 4a_1x^3 + 6a_2x^5 + 8a_3x^7$$

*Equation 12 Fresnel Lens Equation*

### 4.6.2 Planoconvex Lens

A planoconvex lens is the most common type of lens used in optics. It is a lens that has one flat surface and one curved surface that allows for light to be focused, collected, and collimated. The two surfaces of the planoconvex lens work together by focusing parallel light rays to a focal point.



Planoconvex lenses can be designed to have either long or short focal lengths to manipulate where an image forms and the magnification of the image. For the OptoSmart Pet Feeder having a short focal length in the image plane is advantageous since allows for light emitted by the LED to diverge from the lens and enable the camera system to identify the LED color more easily from a greater distance and a larger angle.

#### 4.6.2.1 Zemax (Optics Studio) Calculations for N-BK7 Lens

The pet collar tag for the OptoSmart Pet Feeder must be small enough to comfortably fit on a pet's collar without the device being cumbersome for the animal. We are limiting the size to be no larger than a diameter 1.5" and a depth of 2" all while allowing the light from the LED to diverge.

These factors were plugged into Zemax and we have determined that the LED would need to have a viewing angle of no less than 40 degrees and would sit at a maximum of 20 mm away from the lens in order to maximize the amount of dispersed light from the tag. By doing this, the LED would not need to be as bright as it would need to be without the lens and in the process saves battery power.

A spot diagram was also taken of this lens system to determine the uniformity of the light passing through the system, and it was determined that the uniformity of light at the distances needed for this project is acceptable. It is also important to mention that since we will be using three different wavelengths for this project

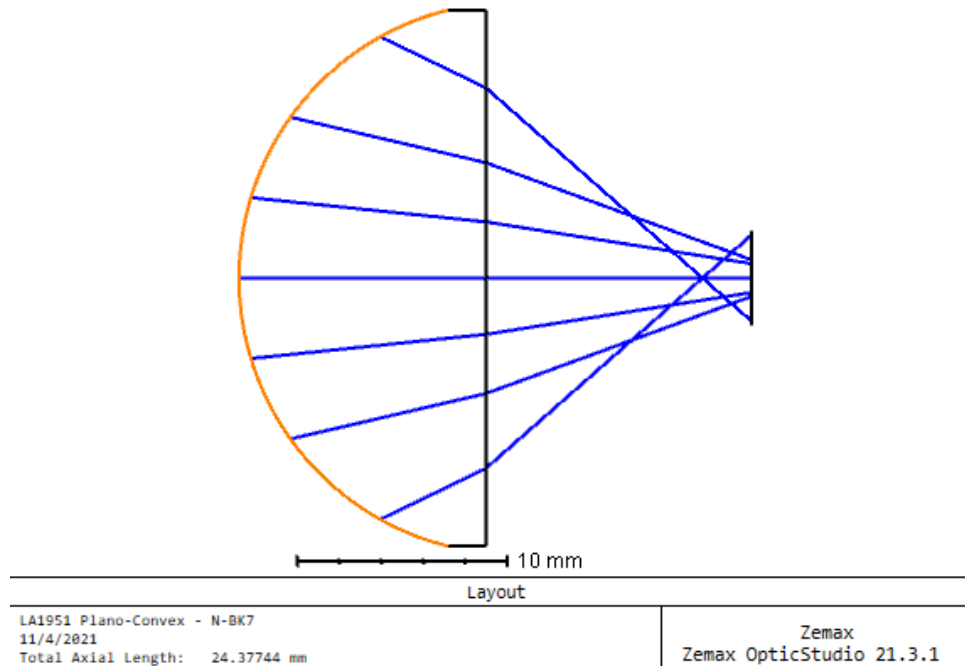

Figure 27: Layout of Plano-Convex Lens

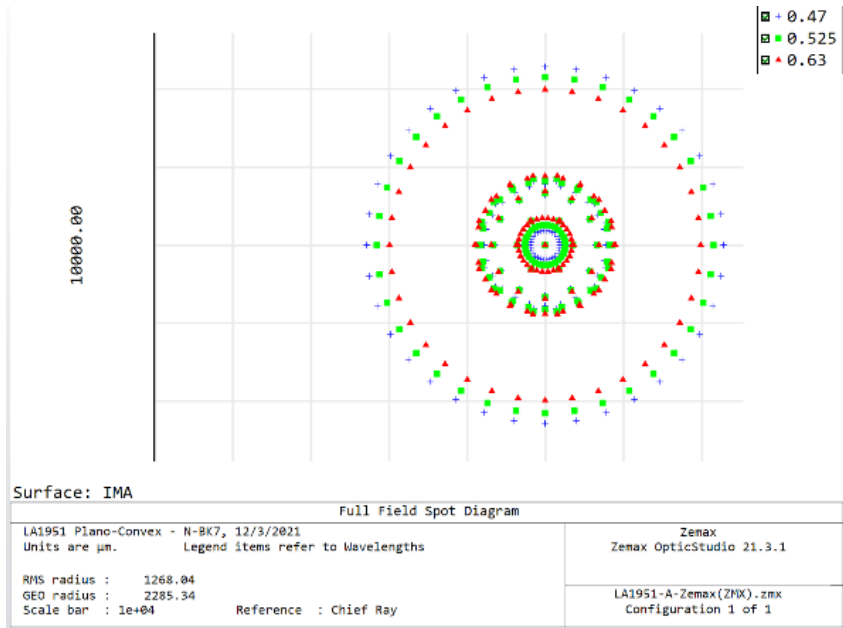

Figure 28 Spot diagram of plano-convex lens

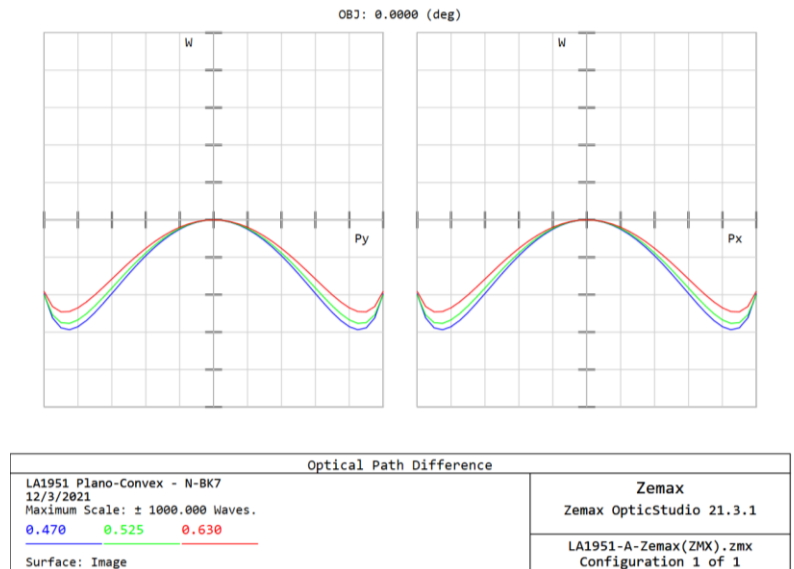

Figure 29 Optical path difference of the Planoconvex lens

#### 4.6.2.2 LA1951 – N-BK7 Plano-Convex Lens

From the calculations in section 5.5.2.2 The OptoSmart Pet Feeder team is looking for a plano-convex lens with a focal length of 25mm and a 1inch diameter. Since this lens will be used for three different wavelengths no AR coatings are necessary.

The LA1951 (seen below), meets the criteria of the project at a price of \$25.14 per lens. This is the lens that matches the parameters of the project the closest and at the lowest price, so this will be the only lens considered for this project.



*Figure 30: LA1951 Lens from ThorLabs*

#### **4.6.3 Fresnel Lens**

Fresnel lenses are made up of concentric circles which can take light and turn them into a narrow beam. This concentrates the light and allows it to be focused on a certain direction as shown in Figure 31.

Fresnel Lenses have a short focal length so it can be relatively close to the LED in the collar which would help with keeping the collar more compact. Fresnel lenses tend to be made of plastic which allows them to be less expensive, more durable, and lighter.

Fresnel lenses can be used for light collimation, light collection, and even magnification. Theoretically, a Fresnel lens can be created to have the perfect dimensions and focal length for a given distance but, this is very difficult to do due to the nature of the material that Fresnel lenses are made of (plastic) for the purposes of this project it would be difficult to find a Fresnel lens that would match the focal length and dimensions we need off the shelf.

If the device were to use a Fresnel lens it would need to be close to the dimensions required by the project and within a certain tolerance.

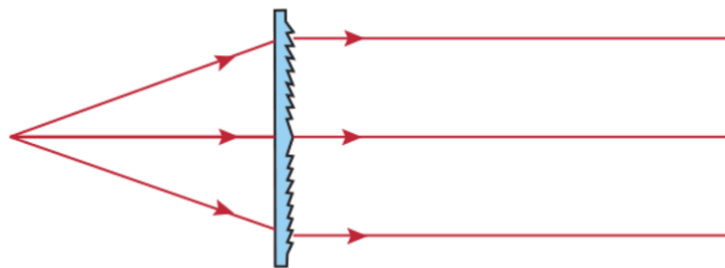

*Figure 31 Fresnel Lens*

#### 4.6.3.1 Zemax (Optics Studio) Calculations for Fresnel Lens

This section is dedicated to the Zemax calculations of the Fresnel lens and how it responds to light being emitted from a point source as illustrated in the figure below, where the light being emitted from a point source is 633 nm.

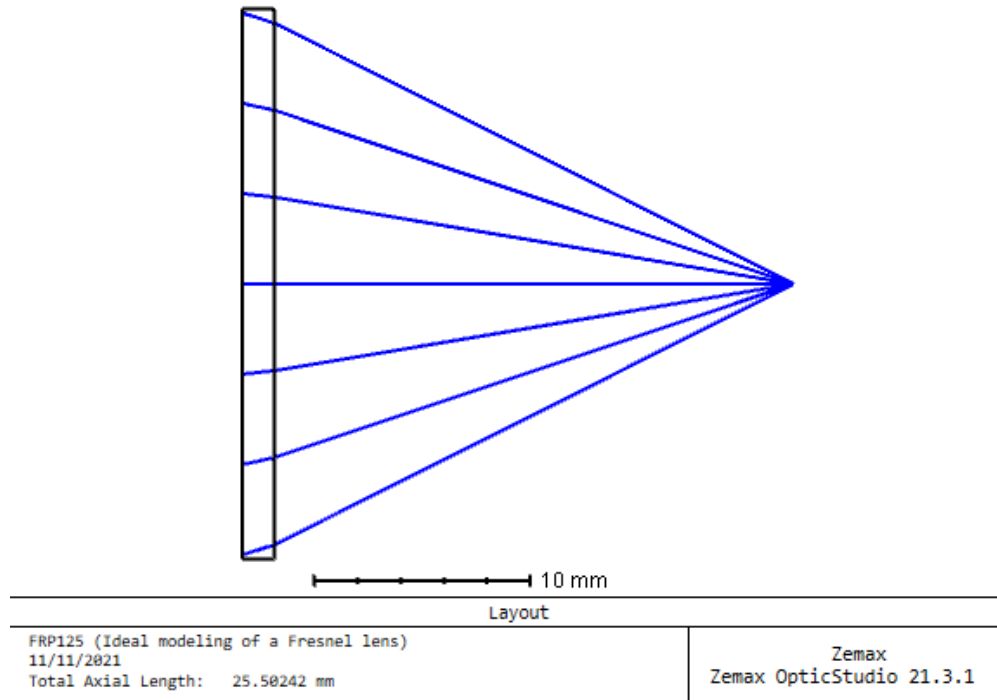

Figure 32 Layout of Fresnel Lens

The dispersion of light from 25mm aligns perfectly with the lens. Another boon to using the Fresnel lens is that the points spread function shown in Figure 34 has a high intensity in its center and disperses on the fringes with a Sinc function pattern this configuration allows for a decent amount of intensity from the LED all while still diffusing the light. This concept is important for the creation of our design.

The drawbacks to using a Fresnel lens can be seen in Figure 33, where the lens works great for the blue light being emitted at 470nm, the spot diagram is nicely uniform and spreads the light evenly over a large surface.

The green light being emitted at 532nm performs average where the spot size of the light is smaller than the blue but is still making the beam larger. The Fresnel lens does nothing for the red lens and the beam passes directly through this alone makes the Fresnel lens unsuitable for use in the Opto-Smart Pet feeder design.

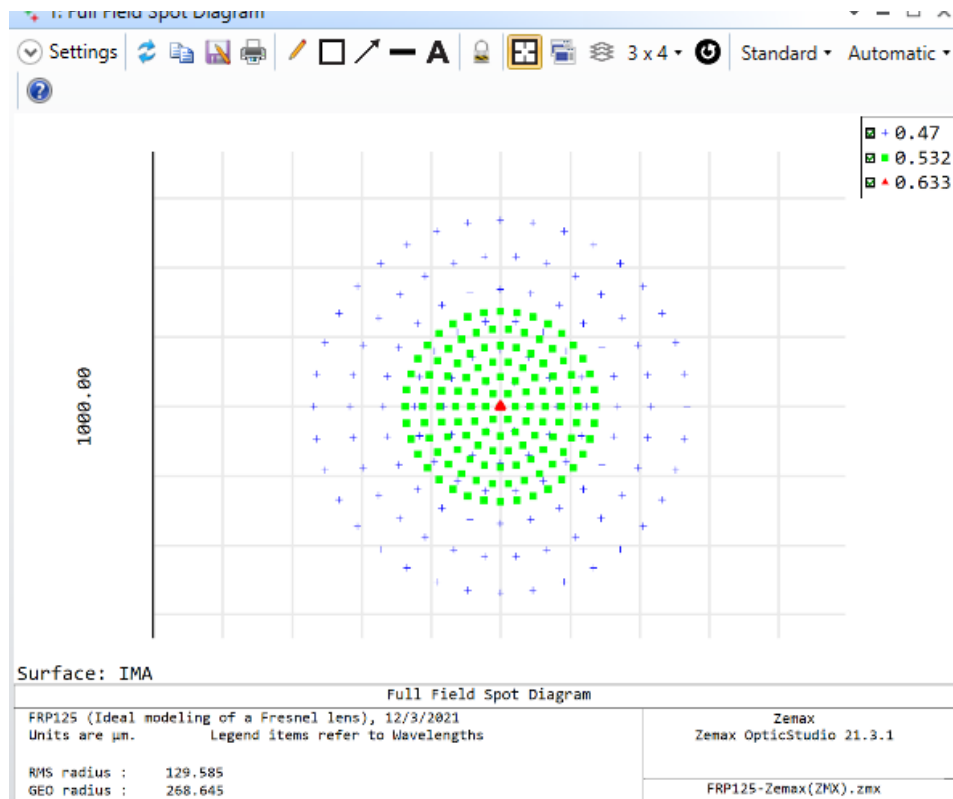

Figure 33 Spot Diagram of Fresnel Lens

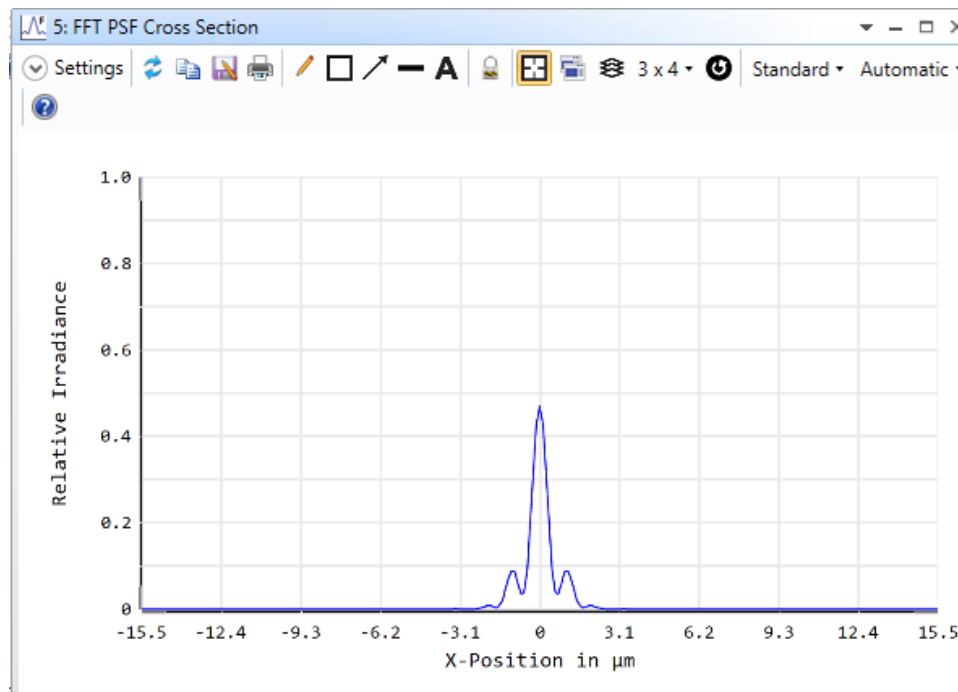

Figure 34 Point Spread Function

#### 4.6.3.2 FRP125 Lens

The FRP125 Lens is sold on Thorlabs for \$23.27. It is 1" in diameter and has a 25 mm focal length. It is 1.5 mm thick and is light weight at only 0.04 pounds. The lens is made of acrylic and the groove spacing is 0.25 mm.

The designed wavelength is 588 nm, this would make it less efficient when the light is further away from the wavelength this lens was designed for. It has a refractive index of 1.49 and an abbe number of 55.3.

#### 4.6.3.3 Shappy Thin Fresnel Lens Pocket Size Magnifier Lenses

Amazon sells a 20-piece pack of pocket size Fresnel lenses for \$9.59. The dimensions are 3.35 x 2.17 x .04 inches. It is made of PVC plastic material and is thin, bendable, and lightweight. It has a magnification factor of 3x. This is a low-cost option.

The downside of using this product is that it is not optimized for any of the three wavelengths we are using

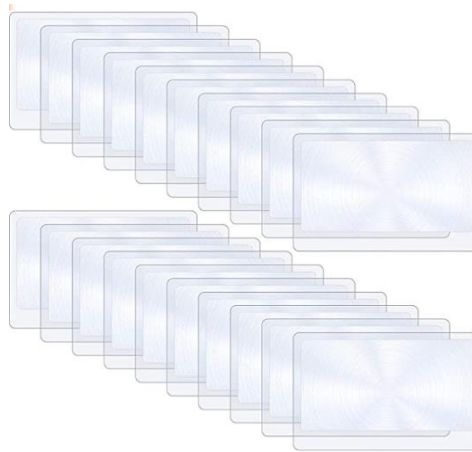

*Figure 35 Shappy Fresnel Lens*

#### 4.6.4 Lens Comparison

We have decided to use the LA1951 N-BK7 Plano-Convex Lens due to the wide variety of wavelengths that this single lens allows when compared to its Fresnel lens counterpart.

The FRP 125 responds very well to red 633 nm light but does a very poor job at diffusing light at shorter wavelengths. The Plano-Convex lens simplifies the issue of diffusion differences at different wavelengths for a similar price when compared to the Fresnel lens.

The spot size for the planoconvex is much more defined not only at 633 nm but at 532 and 480. The Fresnel lens performed poorly at 532 and very poorly at 480 nm (its spot diagram was undetectable).

After comparing the pros and cons of both lenses, the planoconvex lens outperforms the Fresnel lens in almost every way for this specific project.

*Table 13 Lens Comparison*

<b>Lens Options</b>
LA1951 N-BK7 Plano-Convex Lens
FRP 125 (Fresnel Lens)
Pocket Size Magnifier Lenses
<b>Chosen Component</b>

## **4.7 Color LEDs**

Light emitting diodes (LED) are devices that emit light when current flows through them. The color of the light emitted depends on the energy required for the electrons to cross the bandgap of the semiconductor.

In the past, consumers were limited to single color long wavelength (red) LEDs that were inefficient to operate for long periods of time and had a low light intensity. Nowadays LEDs come in almost every color and have become much more efficient to operate when compared to other light sources.

The size of the devices is also a boon to this project since the device emits a constant bright light and little heat. In this section we will research the advantages and disadvantages single color and tri-color LEDs and the process of creating three different collars with one type of LED or the other.

### **4.7.1 Single Color LED**

LEDs come in a variety of shapes and sizes but for the Opto-Smart Pet feeder we are looking for a small device that can easily fit in a device no larger a three-inch diameter and must not draw much power since the device will run on a single battery. This constraint rules out any type of incandescent light source since they can be large and draws too much power to have the light intensity we are looking for in our product.

One device that would suit our needs for this project would be the LED. Since the device is small and operates more efficiently than conventional incandescent lighting this is a viable option for this project.

An advantage to having a single-color LED is that it would be easy to integrate into a PCB since it is a low power device with only an anode and a cathode to solder to a board, this limits any errors that could arise from building the collar tag PCB. Another advantage of having a single LED is ease of use, since the tag is only capable of emitting one single color this eliminates any confusion of which color goes to which pet since the collar tag would only be capable of producing one color.

#### **4.7.1.1 Red LED Options**

There are almost limitless options on the market when it comes to single color LEDs due to the popularity of the component in modern electronics since these devices can be found in just about anything from medical equipment like status indicators in defibrillators, flashlights, and even children's toys. Though even though the market is saturated with them doesn't mean they are all built the same. Here is a comparison between a few different devices.

##### **4.7.1.1.1 C5SMF-RJF-CT0W0BB2 (Red LED)**

This is a red LED from Mouser Electronics that emits light at a wavelength of 621nm. This LED also has a viewing angle of 40 degrees, a luminous intensity of 2200 mcd (millicandela), the forward current of the device is 20 mA, and the forward voltage is 2.1 V. It has a power dissipation of 130 mW. This LED costs \$0.14 per unit.

This unit was chosen for its all-around qualities of not being great in any field. This LED has a wide viewing angle with a standard luminosity at a price lower than the other two products being researched.

##### **4.7.1.1.2 RL5-R8030 (Red LED)**

This red LED from superbrightleds.com emits light at 630 nm. The LED has a 30-degree viewing angle with a luminosity of 8000 mcd. The forward current for this device is 20 mA with a forward voltage of 2.2 V. This LED has a power dissipation of 80 mW and costs \$0.28 per unit.

The advantage of this LED over the other two is the luminosity, this is three times brighter than the LED discussed in 4.5.3.2.1 and gives this at a narrower viewing angle. This would make seeing the light at a further distance easier without extra help of a lens to collimate the light

##### **4.7.1.1.3 MV50154 (Red LED)**

This red LED sold by digi-key emits light at a wavelength of 660 nm. The LED has a 50-degree viewing angle with a luminosity of 1.5 mcd. The forward current of this device is 10 mA, and the forward voltage is 1.6V. This LED has a power dissipation of 180 mW and costs \$0.34 per unit.



This device is much dimmer than the other devices chosen to be researched, with this the device would draw less power from the DC power supply and rely more heavily on the Fresnel lens to ensure the system would be able to detect the color of the LED.

#### 4.7.1.1.4 Red LED Comparison

The red LEDs that were listed in sections 4.5.3.2 all have clear advantages and disadvantages, a list of features of each LED can be seen in Table 14.

For this project the Opto-Smart Pet Feeder team is looking for an LED that has a wavelength closely matching the desired color between 620nm and 680nm (for this instance we are looking at the color red. Blue and green will be discussed in depth during the design section of this paper).

*Table 14 Single Red LED comparison*

	C5SMF-RJF-CT0W0BB2	RL5-R8030	MV50154
<b>Wavelength (nm)</b>	621	630	660
<b>Operating Current (mA)</b>	20	20	10
<b>Forward Voltage (V)</b>	2.1	2.2	1.6
<b>Viewing Angle (deg)</b>	40	30	50
<b>Intensity (mcd)</b>	2200	8000	1.5
<b>Cost</b>	\$0.14	\$0.28	\$0.34
<b>Chosen Component</b>			

#### 4.7.1.2 Green LED Options

This section, we will discuss the options for the Green colored LED. We will compare all of the different options in order to ensure that we pick the best component for our needs.

This singular LED will be used if we decide to not use a tri-color LED.

#### 4.7.1.2.1 SLR-56MG3F (Green LED)

Digikey sells the SLR-56MG3F green LED for \$0.59. It operates at 572 nm. It operates at a current of 10 mA. It has a forward voltage of 2.1 V and a viewing angle of 40 degrees. It has a typical luminosity of 16 mcd.

#### 4.7.1.2.2 Super Bright Green 5mm LED (25 pack)

Adafruit sells a pack of 25 super bright LEDs for \$8.00. It operates at 520 nm. It has an operating current 20 mA and has a forward voltage 3.2 – 3.8 V. It has a viewing angle of  $\pm 10$  degrees. It has a typical intensity 8000 mcd which is significantly higher than the other LED option.

#### 4.7.1.2.3 ALMD-CM3E-Y1002 (Blue LED)

The ALMD-CM3E-Y1002 Green LED is sold by Mouser for \$1.47. It operates at 525 nm. It has an operating current of 30 mA. It has a forward voltage of 3.2 V. It has a viewing angle of 30 degrees, its typical intensity is 9,300 mcd which is the highest of all of the researched green LEDs.

#### 4.7.1.2.4 Green LED Comparison

The green LEDs that were listed in section 4.7.1.2 all have clear advantages and disadvantages, a list of features of each LED can be seen in Table 15.

For this project the Opto-Smart Pet Feeder team is looking for an LED that has a wavelength closely matching the desired color between 520nm and 580nm.

*Table 15 Green LED Comparison*

	SLR-56MG3F	Super Bright Green 5mm LED (25 pack)	ALMD-CM3E-Y1002
Wavelength (nm)	572	520	525
Operating Current (mA)	10	20	30
Forward Voltage (V)	2.1	3.2-3.8	3.2
Viewing Angle (deg)	40	20	30
Typical Intensity (mcd)	16	8000	9300
Cost	\$0.59	\$8.00 (for 25)	\$1.47
<b>Chosen Component</b>			

#### 4.7.1.3 Blue LED Options

This section will discuss the options for the blue colored LED. We narrowed our selection of blue colored LEDs down to three different LEDs that have the potential to work well within our project design. Most of these LEDs feature similar specifications, but there is quite a bit of variation within the intensity values as well as the cost of the three LEDs. In the following part of this section, we will go in depth into the specifications of each selected blue colored LED and compare relevant specifications to finally choose which blue LED will work best in our design.

##### 4.7.1.3.1 C503B-BCS-CV0Z0461

Digi key sells the C503B-BCS-CV0Z0461 Blue LED for \$0.21. This is incredibly cost efficient. It operates at a wavelength of 470 nm. It has a forward voltage of 3.2 V and an operating current of 20 mA. It has a viewing angle of 30 degrees and has an average intensity of 4800 mcd.

##### 4.7.1.3.2 Super Bright Blue 5mm LED (25 pack)

Adafruit sells a pack of 25 bright blue LEDs for \$8.00. It operates at a 465 nm wavelength. It has a forward voltage between 3.2 and 3.8 V. It has an operating current of 30 mA. It has a 20-degree viewing angle, with an intensity of 7000 mcd.

##### 4.7.1.3.3 APTD1608QBC/D

Mouser sells the APTD1608QBC/D Blue LED for \$0.50. It operates at a wavelength of 470 nm. It has an operating current of 20 mA and a forward voltage of 3.3 V. It has an intensity of 250 mcd with a viewing angle of 40 degrees. This LED is much less bright than the other options.

##### 4.7.1.3.4 Blue LED Comparison

The blue LEDs that were listed in section 4.7.1.3 all have clear advantages and disadvantages, a list of features of each LED can be seen in Table 16.

For this project the Opto-Smart Pet Feeder team is looking for an LED that has a wavelength closely matching the desired color between 450nm and 480nm. Another important feature is that the intensity is large, while also keeping the component affordable.

C503B-BCS-CV0Z0461 is a good choice for our design as it has a large intensity, is inexpensive and most importantly is the correct wavelength.

Table 16 Blue LED Comparison

	<b>C503B-BCS-CV0Z0461</b>	<b>Super Bright Blue 5mm LED (25 pack)</b>	<b>APTD1608QBC/D</b>
<b>Wavelength (nm)</b>	470	465	470
<b>Operating Current (mA)</b>	20	30	20
<b>Forward Voltage (V)</b>	3.2	3.2-3.8	3.3
<b>Viewing Angle (deg)</b>	30	20	40
<b>Intensity (mcd)</b>	4800	7000	250
<b>Cost</b>	\$0.21	\$8.00 (for 25)	\$0.50
<b>Chosen Component</b>			

#### 4.7.2 Multi Color LED

Rather than relying on a single LED to for a single color a single LED can be used to display multiple colors. These LEDs are three different LEDs consisting of a red, green, and blue LED combined into a single compact epoxy housing.

A great advantage to this technique is that the current can be varied across the three separate colors to produce different colors. Another advantage of this technique is that this component has a much smaller profile compared to three single color LEDs paired closely together.

The pinout of a multicolor LED differs from the standard single-color LED that consists of an anode and a cathode. These multicolor LEDs can have between four and six pins (the pinout for the device the Opto-Smart Pet Feeder will use will have four pins so the remainder of this document will discuss this one). The LED uses either a common cathode or anode for all three LEDs and a cathode or anode just for red, green, and blue (see figure 18 for pinout diagram).

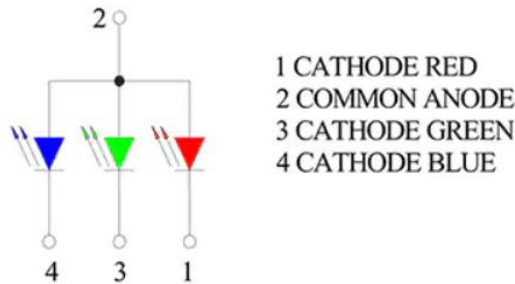

Figure 36 Pinout diagram for a Multi Color LED

(Courtesy of digikey.com)

#### 4.7.2.1 Multicolor LED Options

In this section we will discuss the options for a multi color LED.

#### 4.7.2.2 NTE30159 (Multi-Color LED)

The NTE30159 multicolor LED sells as a 3-pack for \$2.40 or \$0.80 per unit. This device contains a red, a green, and a blue LED inside of one clear epoxy dome. The pinout for this device is the same as what is listed in: Figure 36 Pinout diagram for a Multi Color LED.

One thing to keep in mind for this device is each of the colors have a different minimum and maximum forward voltage. The forward voltages for this device can be found in table \$. Luminous intensity differs for each LED as well. The luminous intensity for each of the LED colors can be found in Table 17.

The viewing angle for this device 20 degrees. This is half the viewing angle the Opto-Smart Pet feeder calculated for the optimal viewing angle for the lens being used in the pet collar found in section 4.6.2.2.

#### 4.7.2.3 WP154A4SUREQBFZGC (Multi-Color LED)

The WP154A4SUREQBFZGC multi-color LED costs \$1.98 per unit. This device contains a red, a blue, and a green LED inside of one clear epoxy dome. The pinout for this device is the same as what is listed in Figure 36 Pinout diagram for a Multi Color LED.

For this device, the red, blue, and green all have different forward voltages, luminous intensities and of course wavelengths these values will be listed in Table 17. The viewing angle for this device is 50 degrees, this is within the Opto-Smart Pet feeder teams acceptable calculated tolerance for working with the chosen lens found in section 4.6.2.2. The Spectral intensity graph for this LED is shown in Figure 37.

## RELATIVE INTENSITY vs. WAVELENGTH

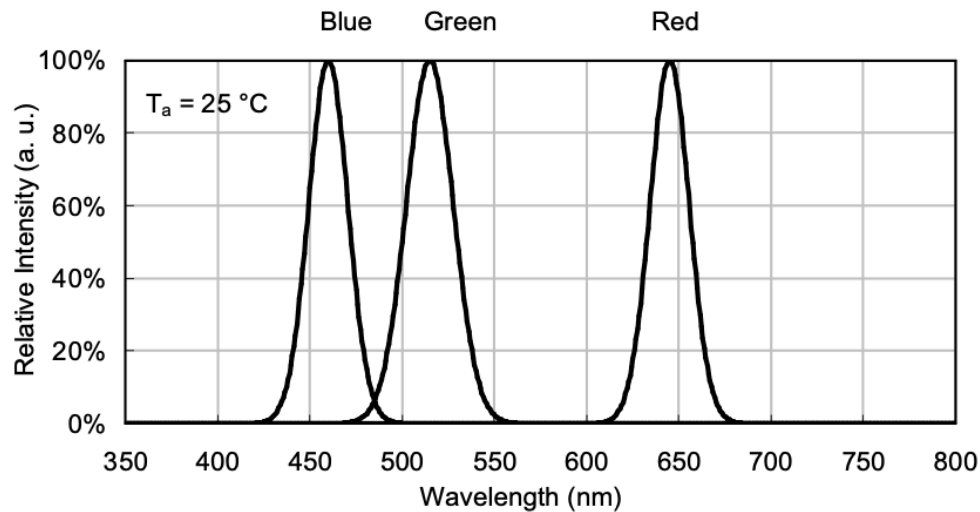

Figure 37: WP154A4SUREQBFZGC Intensity Spectrum

### 4.7.2.4 FD-5WSRGB-A

The FD-5WSRGB-A multi-color LED sells as a 25 pack and costs \$12.50 or \$0.50 per unit. This device contains a red, a blue, and a green LED inside of one clear epoxy dome. The pinout for this device is the same as what is listed in Figure 36 Pinout diagram for a Multi Color LED.

For this device the red, blue, and green all have different forward voltages, luminous intensities and of course wavelengths these values will be listed in table \$. The viewing angle for this device is 60 degrees, this is within the Opto-Smart Pet feeder teams acceptable calculated tolerance for working with the chosen lens found in section 4.6.2.2.

### 4.7.2.5 Multi-Color LED Comparison

The table below compares various multi-color LEDs that we could use if we choose to use multi-color LED over the singular LED. In Table 17, three different multi-color LEDs are compared against each other with the same parameters that were used for the single-color LEDs. The only difference with these comparisons is that three separate wavelength comparisons must be done in order to cover the different wavelengths that occur at each different color of light that the LED can produce. Additionally, the forward voltage and intensity also vary when the color produced by the LED is changed. The forward current and the viewing angle, however, are constant among any color that the multi-color LED is set to produce.

After careful analysis of Table 17 and the previous single color LED comparison tables, we have decided to not use a multi-color LED. Instead, we will make three separate color collars. This will allow us to choose the perfect specifications for each color that will best suit our needs.

Table 17 Multi Color LED Comparisons

	<b>NTE30159</b>	<b>WP154A4SUR EQBFZGC</b>	<b>FD-5WSRGB-A</b>
<b>Wavelength Red (nm)</b>	625	630	630
<b>Wavelength Green (nm)</b>	525	525	525
<b>Wavelength Blue (nm)</b>	465	460	460
<b>Forward Voltage: Red (V)</b>	2.1	1.9	1.9 – 2.3
<b>Forward Voltage: Green (V)</b>	3	3.3	3.0 – 3.4
<b>Forward Voltage: Blue (V)</b>	3	3.3	3.0 – 3.4
<b>Intensity: Red (mcd)</b>	9000	400	3000
<b>Intensity: Green (mcd)</b>	7000	1700	5000
<b>Intensity: Blue (mcd)</b>	6500	900	900
<b>Forward Current (mA)</b>	20	20	20
<b>Viewing Angle (deg)</b>	30	50	60
<b>Cost</b>	\$0.80 (Sells as a 3 pack)	\$1.98	\$0.50 per unit (Sells as a 25 pack)

### 4.7.3 Single Color Vs. Multicolor Comparison

For this project, the Opto-Smart Pet Feeder Team has decided to use the single-color LEDs. This reasoning was decided due to the simplicity of the single-color LED. The device only uses 2 lead system whereas the multicolor LED uses a 4-lead system.

The multicolor LED was also found to put more strain on the battery since each color required a different voltage and more resistors would need to be included in the collar tags PCB. We also decided that the user may find switching the colors of the LED to be cumbersome and confusing, which could lead to a user error where the wrong LED could

be selected resulting in a pet not being fed. The overall design of the single-color LED system eliminates this variable.

## 4.8 Camera System

The camera system will constantly be monitoring the area in front of the Opto-Smart pet feeder. When it identifies the designated bright LED, it will recognize the assigned dog that is trying to eat based off the color of the LED.

Seeing the assigned color will activate the system to start the process of opening the lid. The process of choosing a camera that will be able to be integrated into our project will be described below.

### 4.8.1 Raspberry Pi Camera v2

The Raspberry Pi v2 Camera as shown in Figure 38 is sold by CanaKit for \$25. It is made by the company that makes the Raspberry Pi microprocessor, which will ensure it could be easily integrated. It supports up to 1080p. It is 8 megapixels with a resolution of 3280 x 2464-pixel static images. It is small, sizing at only 25 mm x 23 mm x 9 mm.

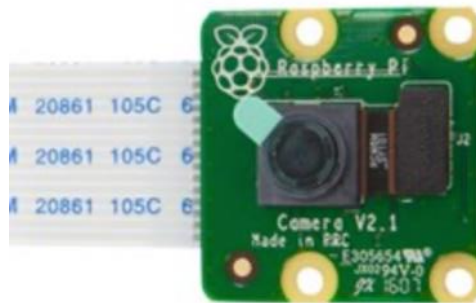

*Figure 38 Raspberry Pi Camera v2*

### 4.8.2 BBTO OV5647 Mini Camera Module

The two pack BBTO OV5647 Mini Camera Module is sold on amazon for only \$10.39. It is compatible with the Raspberry PI 4, 3, 3B+, and 2 models. It records in 1080P with a focus lens of 5 megapixels. It captures still images with a resolution of 2592 x 1944. It is small and compact with a size of 25mm x 24 mm x 9 mm.

The Raspberry PI has small sockets, and this camera can be integrated into it. The way it can be attached to the Raspberry PI 4 via its 6-inch ribbon cable as shown in Figure 39. This set comes in a two pack which is perfect if we want to enact out stretch goal of creating a live feed video, as described in 2.3.3.



It is also great to have a backup just in case the first one breaks. Costing an average of only \$5.20 each, it is a low cost, easily integrated option for our design if we choose to use a Raspberry Pi Microprocessor.



Figure 39 OV5647 Mini Camera Module

#### 4.8.3 Ximimark USB Camera (LY096)

Another option to integrate the camera feature is to use the Model LY096 Ximimark USB Camera which is sold on Amazon for \$7.79. It is a USB camera whose focus can be adjusted on a computer but is able to be integrated into a Raspberry Pi microprocessor.

It can be plugged into one of the USB ports on the Raspberry Pi as shown in Figure 40. It has a retractable cable so it saves space, yet also can be used at different distances. It is 640 x 480 p. It is 3.8 cm x 1.5 cm x 3 cm.



Figure 40 Ximimark USB Camera

#### 4.8.4 Arducam Mini Camera Module (OV2640)

The Arducam OV2640 Mini Camera is sold on Amazon for \$25.99. It can be integrated into both a Raspberry Pi module as well as an Arduino board, which is useful if we decide to use the Arduino board. The Raspberry Pi also only has one CSI port, so it may be beneficial to use the Arduino if we do choose to enact our stretch goal of having an additional camera that owners can use to watch their pets.

It has a 2 mega pixel image sensor and has a built-in IR block filter so that only visible light will enter the camera. The camera is 2 x 1.7 x 1.6 inches. It can be integrated as shown in Figure 41.

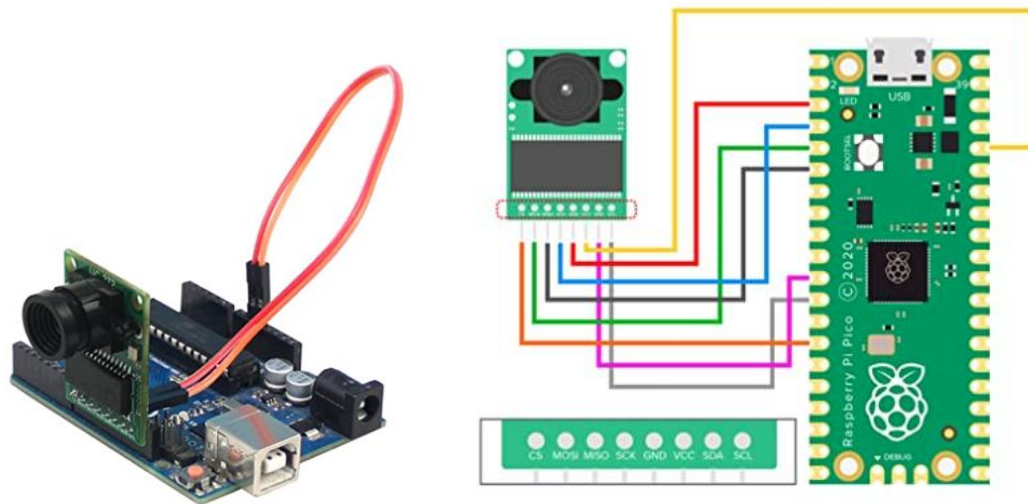

Figure 41 Arducam Mini Module OV2640

#### 4.8.5 Camera Comparison

The table below will compare the cameras researched above to allow us to buy the best camera for our project.

It is important for our design to optimize cost, without hindering functionality. Since all of our options are compatible with the Raspberry Pi, we can maximize our cost efficiency.

For our design we have decided to use the BBTO OV5647 Mini Camera Module as it is the most cost efficient. It comes with two cameras, which gives us the opportunity of possibly enacting our stretch goal. It has a comparable size and resolution to the more expensive cameras and has a CSI port so that it will successfully connect to the Raspberry Pi.

Table 18 Camera Comparison

	Raspberry Pi Camera v2	BBTO OV5647 Mini Camera Module	Ximimark USB Camera (LY096)	Arducam Mini Camera Module (OV2640)
<b>Port Type</b>	CSI	CSI	USB	Pins
<b>Compatibility</b>	Raspberry Pi	Raspberry Pi	Raspberry Pi	Raspberry Pi and Arduino
<b>Resolution</b>	1080p	1080 p	640 x 480 p	-
<b>Size</b>	25 x 23 x 9 mm	25 x 24 x 9 mm	3.8 x 1.5 x 3 cm	2 x 1.7 x 1.6 inches
<b>Cost</b>	\$25	\$10.39 For 2	\$7.79	\$25.99

#### 4.9 Food Dispenser

The food dispenser must be able to output the correct amount of food (depending on what pet is currently being fed) in at most 60 seconds. To accomplish this, the dispensing system will consist of a dispensing wheel and a DC motor to power the spinning of the wheel.

Since the dispensing wheel will not be operated at high rpm, a low power motor will work perfectly in this case. The motor will be connected to the dispensing wheel, enabling food to be released from its stored container when the wheel is spun. Like the functionality of a gumball machine, each turn of the dispensing wheel will release a small amount of food from the storage container.

Due to the controlled nature of the dispensing, the exact amount of food released per wheel rotation can be determined to calculate the time it takes to fully dispense a complete meal (using the wheel rpm as a guideline).

#### 4.10 Microcontroller

To prototype and test the internal circuitry of the Opto-Smart Pet Feeder, an adequate microcontroller must be selected to accomplish all tasks within the scope of our project. The microcontroller used within the pet feeding device (not including the collar) must be able to interface with the application that will be developed for user interaction with the product.

In addition, the selected microcontroller will require the capability to communicate with the DC motors used in the pet feeder and both monitor and control the rpm at which the motor is run. The microcontroller chosen for this project must also be able to interface with

the selected webcam (to provide color detection) via native hardware or some type of adapter that can be obtained/created.

Below are the microcontrollers that would best adhere to the scope of the Opto-Smart Pet Feeder.

#### **4.10.1 Arduino Uno Rev 3**

The Arduino Uno Rev 3 (using ATmega328P onboard microcontroller) shown in Figure 42 will be able to deliver the hardware level actions that are needed for the per feeder, such as activating the DC motor when the correct color data is received and turning on and off the lid closing system.

This microcontroller will not be able to handle the image processing from the data that is received directly from the webcam, so an additional microprocessor will be needed to process the color from the image and send the color data to the Arduino.

Using an Arduino for this project will allow for use of multiple color detection and imaging libraries that currently exist (due to the open-source nature of Arduino programming). The onboard features of the Arduino Uno Rev 3 include:

- Single 16-bit timer with both compare and capture modes
- Two 8-bit timers with compare mode
- 10-bit Analog to Digital converter
- SPI, I2C, and UART interfaces
- Operating Voltage between 1.8V and 5.5V
- Clock Speeds up to 16 MHz



*Figure 42 Arduino Uno Rev 3*

#### **4.10.2 MSP 430FR6989**

The TI MSP 430FR6989 shown in Figure 43, is another viable option for a microcontroller that will be used to interface with the DC motor, lid closing system, and data from the processed image.

Although the MSP430 can be interfaced with a microprocessor (that is able to obtain color data from an image in real time), there is less ease of programming with the MSP430 since there is no way to access multiple existing libraries that can assist with color detection and processing.

For approximately the same price as the MSP 430FR6989, the Arduino Uno Rev 3 will most likely allow for the same hardware/software capability while proving a more user-friendly programming and setup experience. When entering the prototyping and testing stage of the project design, both the Arduino and TI microcontrollers may be tested within the project to determine which will ultimately be the more efficient option for the final product. The onboard features of the TI MSP430FR6989 include:

- 12-bit Analog to Digital converter
- Five 16-bit timers with compare and capture modes
- SPI, I2C, and UART (with automatic Baud-rate detection) interfaces
- Operating Voltage between 1.8V and 3.6V
- Clock Speeds up to 16 MHz

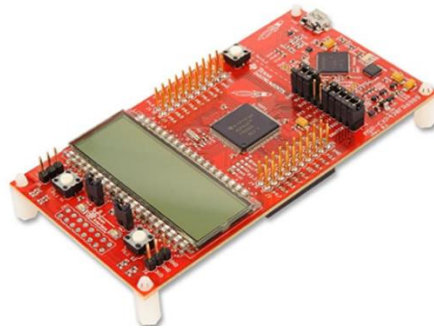

*Figure 43 MSP 430FR6989*

## **4.11 Microprocessor**

A microprocessor is a computer processor that incorporates the functions of a CPU onto just a few integrated circuits. The microprocessor selection is essential in the developmental process of our project as choice of microprocessor will directly impact any formation of the digital functionality that will further control the I/O peripherals of the physical functionality of the device.

### **4.11.1 Raspberry Pi 4**

A Raspberry Pi 4 is the latest version of the low-cost Raspberry Pi microprocessor that directly plugs into a monitor and uses the general computer peripherals such as keyboard and mouse to use.

This device can achieve any basic computer functionalities such as browsing the internet, playing HD video, creating spreadsheets, word processing, playing games, etc. A

Raspberry Pi 4 mostly uses the programming language Python and has its own OS (operating system) called Raspbian to operate and use all its capable functionality.

The Raspberry Pi 4 has an RAM of 2,4, or 8GB, with an USB 2, and 3 ports, Micro HDMI ports that supports 4K, an USB-C Power Supply, as well as a Gigabit Ethernet port.



*Figure 44 Raspberry Pi 4*

## **4.12 Coding Language(s)**

The correct selection of choosing which coding language(s) to use for our project is key to properly create a successfully working system overall.

This section displays all the different coding languages that can be utilized. This way The OptoSmart Pet Feeder team has a method to design, develop, or prepare our project to get to the finish product that is desired, as well as a detailed comparison table at the end to fully list, display, and of course compare all the unique and distinct differences between the coding languages that could be put into good use.

### **4.12.1 C**

The C language is a high-level, structure-oriented language that focuses mostly on the implementation of functions to perform most actions within the program. While general purpose languages such as python can be applied to almost any scenario, C is mainly used to develop code to aid in hardware and firmware interactions.

C requires a compiler to compile and run the code, meaning that the entirety of a program's code will be converted into binary code and then executed by the machine (machine running the code) every time the program is run.

Additionally, the C language does not have many built in functions that can be implemented. Instead, many functions must be developed by the programmer to be implemented within the program. The C language also has a strict language syntax that must be learned and followed, unlike python (which is written more like a spoken language).

### **4.12.2 C++**

C++ is a language that is a superset of C, and C++ supports polymorphism and inheritance due to it being an object-oriented language. In C++, both data and the developed functions can be linked together using objects, but C only supports procedural programming (data and developed functions are separated).

Since C++ is built as a language that provides additional functionality to C, it is usually simpler to program in C++ due to the easier tools that are added into the C++ language. Another contrast between C and C++ is the fact that C is mainly used to implement a top-down approach, while C++ is used to implement a bottom-up approach (meaning smaller modules are first developed before combining them into the main program code).

C++ can accomplish most of the tasks that C can do, while including more features and being easier to utilize. Learning how to program in C will translate to being able to program in C++ without much difficulty, and C can still be used for certain applications that require higher speed without the need for the added features of C++.

### **4.12.3 C#**

C# is a type-safe, general-purpose, modern, and object-oriented programming language. C# enables developers to build many different types of secure and robust applications that compile run in .NET. C# has been derived from the C family of languages and will be noticed and recognized as the codes are all like all other languages such as C, C++, Java, and JavaScript as the language complements one another very effectively.

C# is widely used by my programmers for developing desktop applications, web applications and web services. However, generally C# is used to create applications that is compatible with Microsoft at a large scale. C# is also somewhat used in game development industry to improve the quality of games for the respective developers.

### **4.12.4 Java**

Java is a multi-platform, general-purpose, class-based, network-centric, object-oriented programming language that is fast, secure, and reliable, therefore, is preferred to use by most programmers, including top-level programming organizations to use for their coding projects.

The most important aspect of Java is the fact that it is an object-oriented language, which means that all the programs are made of entities representing concepts or physical structures called objects. Java is a very popular coding language to use by many simply because of its platform usage being separate to all other compilers. Java Runtime Environment (JRE) is the only part necessary in to be installed to the digital device for the java code to compile and run correctly.

Regardless of whether it is installed in a desktop PC running Windows, Linux, or Unix, or a Macintosh computer running Mac OS. Java's syntax is derived from C and C++ which allows for many programmers who are not familiar to Java but know C or C++ to quickly adapt and use the Java coding language.

#### **4.12.5 JavaScript**

JavaScript is a programming scripting language that allows the programmer to implement complex features on the webpage. JavaScript is the code used to write functions to the webpages written in HTML. However, in webpages created in recent times, both the webpages, and the functionality of those webpages can be both written in the programming language JavaScript.

Whenever there is a functional purpose being involved in a webpage that involves actual methods and parameters being involved, it has something to do with JavaScript code.

#### **4.12.6 Python**

Python is known by most developers as an object-oriented, very expert-level programming language with an effectively definition of a coding developer's dream to interpret. Often, programmers fall in love with Python because of its increased productivity it provides, as well as there being no compilation step, meaning there are no segmentation faults that occur which allows for the edit-test-debug cycle to be done very efficiently in comparison to other programming languages.

Python also has a simpler syntax and formatting compared to other languages and offers an abundance of libraries for anyone to reference in the source code.

#### **4.12.7 MATLAB**

MATLAB is a programming language and software that is specifically designed for engineers to use as they carefully dive into data collected from their laboratory work, they analyze that data that is presented to them to their specification, and finally the system's unique assignment and production that can potentially transform today's society for the better. The MATLAB language especially is a matrix-based language that is capable and acceptable for most mathematics for the use of the engineers. In MATLAB individuals may again analyze their lab collected data to develop creative and efficient algorithms and can organized personalized models to the specifics of axis for engineers to use at any time as they can take the extreme ideas that they brought up from research to production as they utilized it for their embedded devices to make it into reality.

#### **4.12.8 HTML**

HTML (Hypertext Markup Language) is the most basic building block of the web that is the standard markup language to create web pages as the language describes the content structure of the written webpages.



HTML also displays every written element containing in the webpage such as text and Hypertext. Links are a fundamental aspect of the Web. By uploading content to the Internet and linking it to pages written by either yourself or other, the programmer has actively contributed to the World Wide Web.

HTML can be used to enclose and wrap different segments of the webpage content to make the site appear in a customizable fashion to annotate text, images, and other content for display in a Web browser. There are also tags that are used to encompass the text, image, or hyperlink to display the content to the desired degree on the created webpage to give an identity to specific element.

#### **4.12.9 CSS**

CSS (Cascading Style Sheets) is a programming language that allows for the customization of styling for the webpages, making the websites that are written in either HTML or JS look presentable to the public.

In simpler terms, HTML makes the webpages readable to the user, however, adding a CSS code to a blank HTML webpage allows for the bland webpages to look much better for the user to see. Overall, adding the creative CSS stylings to the blank HTML or JS code allows for webpage to look proper, professional, and overall presentable, whereas a blank HTML or JS page without the CSS stylings is just readable and bland.

CSS is a rule-based language that allows for the programmer to define the rules themselves by specifying each group of styles that they prefer to use be to eventually apply themselves to customize each element in the webpage they are creating.

#### **4.12.10 Haskell**

Haskell is widely regarded to many coding language developers as a general-purpose, statically typed, purely functional programming language with type inference and lazy evaluation. In simpler terms is a very straight forward, advanced functional language that allows you to write code in a very straight forward manner, a sort of you get what you type kind of coding language.

The Haskell programming language purely focuses on “what to solve” in comparison to other languages that target to fix “how to solve.” Haskell allows for the functions to be solved in a very mathematical sense as the programming language is built on top of the foundation of combinatory logic.

The Haskell code is evaluated in real compilation time, as the code compiler evaluates the code before the runtime allowing for the written code to be very correct, clean, and concise when finished.

Shorter development time, tight control of side effects, and scalability, as well as Haskell being cleaner and a more reliable coding language than most attracts a lot of coding

developers to use this code as a language to manage, structure, and scale large amounts of data.

#### **4.12.11 R**

R is a programming language for specifically a statistical computing environment and graphical usage for GUI work and is free of charge. R provides a wide variety of statistical (linear and nonlinear modelling, classical statistical tests, time-series analysis, classification, clustering, and so on) and graphical techniques, and is highly extensible to use.

R is also used to create and further implement machine learning algorithms to investigate, refine, and analyze the given and imputed data for the programming developer. The data analysis in R is done in a very comprehensible and simple to understand steps to make it user friendly to all developers using the language and environment.

These series of steps are programming, transforming, discovering, modeling and communicate the results, all done and completed in different forms of procedures.

As the developers use R to program their language written in code, they transform the code into a collection of libraries designed specifically for data science tailored to their own use, causing the discover of the deeper dive into their own data with further analysis taken place to better modeling their refined data to a greater capture of the essence of what is desired to be displayed. Finally, communicate the results by outputting a report of the data produced by the R environment.

#### **4.12.12 PHP**

PHP also known as Hypertext Preprocessor is an open-source scripting language that is executed on the server and is free of use and is widely used by many programming developers for web development, very similar to other web development programming languages such as HTML, CSS, and JavaScript. In fact, PHP pages contain HTML with embedded code that can be filled with functions that can produce methods by the code executing on the server, generating the HTML sent to the client-side.

When speaking about the PHP coding language, it also goes by mentioning that they produce PHP files that contain text, HTML, CSS, JavaScript, and of course PHP code itself, that is again executed on the server, resulting it to the browser as a plain HTML page.

#### **4.12.13 Coding Language Comparison**

The tables below will be used to compare all the unique and distinct differences between the coding languages that could be put into functional use. An additional note is that all the coding languages mentioned are free to use except for MATLAB. The cost comparison was kept out of all the tables (even the one including MATLAB), since there is no cost disparity present in any other comparison table. The price of MATLAB for students is \$49.99 Also, the following tables will be setup as a continuation of each other and the

comparisons for each coding language will be identical. Within the title of the table, it will be stated whether the table is a continuation of the previous table, or it begins a comparison of three completely different coding languages. The chosen coding language(s) that will be used in this project design will not be explicitly noted in the tables, but rather explained further in the design section of this report.

*Table 19 Coding Language Comparison*

	<b>C</b>	<b>C++</b>	<b>C#</b>
<b>Paradigm(s)</b>	Imperative	imperative, object-oriented, generic	imperative, object-oriented, generic, reflective, functional, event-driven
<b>Standardized</b>	yes	yes	yes
<b>Type checking</b>	static	static, dynamic	static, dynamic (for interop)
<b>Parameter passing methods</b>	by value, by reference (through pointers)	by value, by reference (through reference types)	by value, by reference (through managed pointers [explicitly in, out, or in-out])
<b>Intent for use</b>	System, Embedded	System, Embedded	System, Embedded
<b>Design goal</b>	Low level access, Minimal constraint	Abstraction, Efficiency, Compatibility	Rapid application development

*Table 20 Coding Language Comparison Cont.*

	<b>Java</b>	<b>JavaScript</b>	<b>Python</b>
<b>Paradigm(s)</b>	imperative, object-oriented, generic, reflective	imperative, object-oriented, functional, reflective	functional, imperative, reflective, array
<b>Standardized</b>	yes	yes	No
<b>Type checking</b>	Static	dynamic	Dynamic
<b>Parameter passing methods</b>	By value	By value	By value (Call by object reference)
<b>Intent for use</b>	System, Embedded	Client-side web scripting	System, Embedded
<b>Design goal</b>	Write once run anywhere	N/A	Simplicity, Readability, Expressiveness, Modularity

Table 21 Coding Language Comparison Cont. 2

	<b>MATLAB</b>	<b>HTML</b>	<b>CSS</b>
<b>Paradigm(s)</b>	procedural, imperative, array programming	Markup, Declarative, Domain-specific programming language	Markup, Declarative, Domain-specific programming language
<b>Standardized</b>	No	Yes	Yes
<b>Type checking</b>	Dynamic	Static	Static
<b>Parameter passing methods</b>	By value	tags	tags
<b>Intent for use</b>	Numeric computation and visualization	Web Development	Web Development
<b>Design goal</b>	At the beginning designed as interpreter for easy use of Fortran libraries, nowadays high-performance numerical analysis, and visualization	Lingua Franca for the Web, Simplicity, Scalability, Platform Independent, Content not presentation markup, Support for Cascaded Style Sheets, Support for the Visually Impaired,	allow a browser engine to paint elements of the page with specific features, like colors, positioning, or decorations.

Table 22 Coding Language Comparison Cont. 3

	<b>Haskell</b>	<b>R</b>	<b>PHP</b>
<b>Paradigm(s)</b>	functional, generic, lazy evaluation	functional, imperative, reflective, array	imperative, object-oriented, reflective
<b>Standardized</b>	Yes	No	No
<b>Type checking</b>	Static	Dynamic	Dynamic
<b>Parameter passing methods</b>	by value, by reference	value by need, by name (programmer chosen)	by value, by reference
<b>Intent for use</b>	System, Embedded	Statistics, Numerical computation, Visualization, Education	Web Application
<b>Design goal</b>	lazy evaluation, Teaching and research, completely formally described Report Preface	Expressiveness, interactive manipulation, and analysis of datasets	Robustness and Simplicity

## **4.13 Programming Language Editing Software**

Correctly selecting which programming language editing software to use is very crucial to properly be able to create, edit, and debug the necessary code for the digital aspect of our feeding system to function efficiently.

This section displays all the different programming language editing software that can be utilized to design, develop, or prepare towards our final product. As well as a detailed comparison table at the end to fully list, display, and of course compare all the unique and distinct differences between the programming language editing software that ultimately could be used for our feeder.

### **4.13.1 Atom**

Atom is a text editor that provides a specific syntax highlighting for different programming languages. Atom is the software that will be used to write the programming language to compile it and run the code on the OS (operating system) or Linux. Atom can edit a variety of different programming languages such as Java, JavaScript, Python, C, C++, and so much more. I especially recommend using atom for any beginner programmers who aren't very familiar with code as the software interface is very vanilla and easy to use and comprehend for all users.

### **4.13.2 Visual Studio Code**

Visual Studio Code is a source-code editor made by Microsoft, that allows for debugging, syntax highlighting, intelligent code completion, snippets, code refactoring, and embedded Git. Visual Studio Code can edit a variety of different programming languages such as Java, JavaScript, Python, C, C++, and so much more.

The biggest difference between Visual Studio Code and other text-editor applications are the features that are provided within the software. In Visual Studio Code, programmers may collaborate and code remotely with others who are involved with the project, the pure ability to connect Visual Studio Code to GitHub and being able to push and pull source code from different platforms allow for easy editing use for everybody involved.

### **4.13.3 Repl.it**

Repl.it is a free online IDE (integrated development environment) that allows users to write their own programs and code in 50+ different coding languages.

Repl.it is a completely web-based system, which makes it very convenient. Another great feature about Repl.it is that if shared, many code developers can collaboratively work on a coding assignment all at once in real speed. Similarly, when a word document or google document is shared with many group mates who are all working on the document all at once in real time.

#### **4.13.4 Sublime Text**

Sublime Text editor is a complex text editor which is known to many coding developers. Coding developers frequently use this editor to write code in many programming languages such as Java, C, or Python. Sublime Text also support for front-end languages for web development such as HTML, CSS, and JavaScript.

Sublime Text has many features that help with vigorous efforts of coding many lines of text such as Syntax Highlight for the code that is implemented in a function, Auto Indentation for the structural organization of the key elements in the code, File Type Recognition for the creative and organizational orientation of the code being used, Sidebar for easy access to all the code involved in the project, etc. Unfortunately, users may download and evaluate the Sublime Text programming language editing software for free, however, to use the program on a frequent and consistent basis, the licensing of the product must be purchased one time at a rate of \$80.

#### **4.13.5 Notepad++**

Notepad++ is a source code editor and a Notepad replacement that supports many programming languages such as Java, C, or Python, etc. Notepad++ is run in a Microsoft Windows environment that is overall written in C++ when created initially as it uses a strictly purely based Win32 API and STL that allows for a guaranteed exceptional execution runtime and a very small program size to be able to run on the platform.

As well as Notepad++ being free, yes, free, it has an additional feature supporting tabbed editing, which allows working with multiple open files in a single window.

#### **4.13.6 Programming Language Editing Software Comparison**

The following comparison tables will help to decide on software that we will use to edit the code that will be used for our project design of the Opto-Smart Pet Feeder. Like the coding language comparisons, the cost comparison was taken out of the tables since the only editor that was not free was Sublime Text (an approximate cost of \$80.00). After analyzing tables 28-29, it was apparent that the two best code editors that we would use to write and debug our code are Atom and Visual Studio Code. Both options are free, easy to install (with a low install size) and contain features that will help to speed up the programming process. The feature that stood out the most for Atom was the cross-platform editing that would be useful in the case that multiple group members wanted to help with the software development on various devices. In the case of Visual Studio Code, the auto-completion feature as well as the debugging with breakpoints (in addition to the lightweight nature of the software) made this code editor another top choice for our project's software development.

Table 23 Programming Language Editing Software Comparison

	Atom	Visual Studio Code	Repl.it
<b>Programming Languages</b>	Supports many languages.	Supports many languages.	Supports many languages.
<b>Operating Systems</b>	Windows, Linux, Mac OS	Windows, Linux, Mac OS	Online IDE, Editor, Compiler, Interpreter
<b>Best Features</b>	Cross-platform editing. Built-in package manager	Auto-completion Debugging with breakpoints.	Can code, compile, run, and host all online
<b>Written in</b>	Built using web technologies	TypeScript JavaScript CSS	Built using web technologies
<b>Chosen Editing Software</b>			

Table 24 Programming Language Editing Software Comparison Cont.

	Sublime Text	Notepad++
<b>Programming Languages</b>	Supports many languages.	PHP JavaScript HTML CSS
<b>Operating Systems</b>	Windows, Linux, Mac OS	Windows, Linux, UNIX, Mac OS (By using a third-party tool)
<b>Best Features</b>	Provides instant switching between projects. Cross platform support.	Syntax Highlighting Auto indentation Auto completion
<b>Written in</b>	C++ & Python	C++ And uses Win 32 API & STL
<b>Chosen Editing Software</b>		

## 4.14 OS Distribution software

Selecting the correct OS distribution software to use is essential to properly compile the written code to run and function to create a successfully working fully digital system for our feeder.

This section displays all the different OS distribution software that are available and can be utilized to design, develop, or prepare for our final product. As well as a detailed comparison table at the end.

### 4.14.1 Ubuntu

Ubuntu is an OS Distribution fully complete Linux based system that is currently used in the modern world that is also open-sourced as it is free to enjoy by all developing individuals. This system platform is especially useful for all developers who are attempting to compile code in relation to all, but not limited to C, C++, Java, Python, and more. However, whatever code that is being compiled on Ubuntu must be downloaded via sudo to install the specific package needed to compile and run the designated code.

### 4.14.2 Debian

Debian, also known as Debian GNU/Linux, is a Linux OS distribution software that is structurally composed of a free source and a one of the first of its kind open-source software, developed in 1993 making it one of the first of its kind again to be created for the developers to use for their own benefit of their project, led the way for other OS distribution software to be developed in the future.

### 4.14.3 OS Distribution Comparison

The below table will fully list, display, and of course compare all the unique and distinct differences between the OS distribution software that could be put into use for our final product.

*Table 25 OS Distribution Comparison*

	<b>Ubuntu</b>	<b>Debian</b>
<b>Installation</b>	Stable and streamlined	Iterative and interactive
<b>Target audience</b>	general, server, desktop, supercomputer, IBM mainframe	general, server, desktop
<b>Supported architectures</b>	armhf, i686, powerpc, ppc64el, s390x, x86-64	x86, x86-64, arm, ppc64, loongson, mips, sh, s390x, riscv
<b>Cost</b>	\$0	\$0
<b>Chosen OS Distribution</b>		



## **4.15 Web Application Development Software**

The selection of the correct web application development software is pivotal to properly create a successfully working digital system to fully functional for all individuals to use via the internet.

They offer many advantages, one being they perform all the necessary functions utilizing a web browser instead of installed software for a simple implementation and setup for the user. Plus, cloud-based functionality has web application becoming an essential component of product usage in today's expanding world.

Functional systems are allowing and uniquely creating web applications to publish online from the help of developers to meet their application desires, needs, and demands. Web applications also eliminate the concerns of whether the mobile application for the product works effectively and efficiently on numerous platforms. Its cross-platform capability makes web applications no longer a luxury, a necessity especially for smart devices.

The ability to update themselves without the need for user intervention is also a plus for future improvements on the product interface. This section displays all the different web application development software tools that can be utilized to design, develop, or prepare the final product of our project.

### **4.15.1 React Native**

React Native is an open-source UI software framework that is used to develop by many individuals to create unique web applications that are structurally real, and natively considered as a render, which the webpage application program developers can use as a structural guide of sort for their projects to maximize the proper usage of the JavaScript platform capabilities.

### **4.15.2 Reactjs**

React is basically a JavaScript library that many software webpage developers use to build beautifully modern looking user interfaces that allows the developers to utilize complex UI components that allows for the most optimal solution to creating web applications with high-level of functional use and complex methods and variable call as well as supreme organization that features a fancy, clean, and effortless webpage creation to the naked eye of the digital creation world.

### **4.15.3 Node.js**

Node.js is an open-source, runtime environment, and cross-platform software that can execute code Specifically JavaScript code that is outside of the browser. Quite often we use Node to create API back-end services which are services that power client-based applications such as web applications, the surfaces of these apps need a back-end services

to properly execute a functional service to all users. Node.js is great for agile development, and is quick, very fast that is scalable for many large applications of code.

#### **4.15.4 Express**

Express is a web application framework for Node.js. It is a free, and again an open-source software since it is a subsection of Node.js, and is designed for building web applications and APIs for the developers specific projects. Known to most web developers as the most popular Node web framework, it provides a unique mechanism for the developers to write handlers for requests to factor the proper reference to the web application to post on the internet.

### **4.16 Mobile Application Development Software**

The selection of the correct mobile application development software is critical to properly create a successfully working digital system fully functional for all to use via mobile device. With the growing number of people accessing the Internet via smartphones and tablets, mobile app development has the unique ability to access many potential users of our smart product.

Contrary to web applications designed for desktop computers, mobile applications move away from integrated software systems. Instead, each mobile application provides an isolated and limited functionality for the product. Mobile applications are usually 1.5 times faster than web applications, and they have an added advantage where developers can code various features utilizing the embedded hardware in the native device in use such as the camera, GPS, accelerometer, gyro meter, fingerprints, facial recognition, etc.

The ability to update and push notifications to the application user at the need and desire of the product and being able to provide a user-friendly interface to more complicated functionality can often allow for product, and application users to be less intimidated and feel more comfortable being able to control their specified features remotely. This section displays the mobile application development software tool that can be utilized to design, develop, or prepare our project.

#### **4.16.1 Flutter**

Flutter is a UI Toolkit that makes it easy for mobile developers (either IOS or Android) to design beautiful interfaces and allows for screen size and device accessibility. Flutter allows for the mobile developers to design their unique and creative mobile applications to become seamlessly accessible for all the different types of devices with all kinds of different screen sizes with different access ratio. Flutter first asks for a blank window, and it will draw onto the blank canvas, adding beautiful prebuilt widgets and allow for a mobile application to makes it look like it was created in a native manner.

## **4.17 Database Management Software**

The selection of the correct database management system software is vital to properly create a successfully working digital system fully functional for all to use via the internet. This step is crucial to stash and organize a fully functional database for all server-based systems to rely on for both web and app systems.

This section displays all the different database management system software tools that can be utilized to design, develop, or prepare our project. As well as a detailed comparison table at the end.

### **4.17.1 Firebase**

Firebase is a developmental platform created by Google, that allows for high quality applications to uniquely be established for the developer for their application web-based platform. The major consensus usage for this online platform is to be used as a document database that is well organized and secure for all amateur to expert developers to use for their projects.

### **4.17.2 Heroku**

Heroku is a cloud-based service platform that allows for applications to be run virtually at an instantaneous rate. Developers build, process, and create apps on Heroku to seamlessly host their respective web applications to be able to access via the internet.

### **4.17.3 MongoDB**

MongoDB is a document database that is represented by a NoSQL database used for a very high request volume type data storage for many developers and companies use as they scale growth exponentially. Instead of using just tables and rows in comparison to other old and very outdated document database applications, MongoDB uses the collections of real time change, and effect to the database via the documents.

These documents that are being talked about are consisting of a very specific user detailed key-value pairs which allows for both the user and the developers to reference in MongoDB as they pair the ID to the corresponding user and attach that ID specifically to the values that are forced to be referenced in the functions and methods for later use.

### **4.17.4 MySQL**

MySQL is a document database management system of sort that is an open-source relation to the client-server model of the product in use. MySQL allows for individual developers to build fast and efficient, secure document database storage unit systems quickly and accurately within the OS running the database system as the program syntax stays organized and query values inside the database for the coding languages in the structured virtual data storages to recognize.

#### 4.17.5 Database Management Software Comparison

The below table fully list, display, and of course compare all the unique and distinct differences between the database management software that could be used for our final product.

Firebase and Heroku were chosen as being the best fit for our project. Firebase was made by Google, so it has a lot of security and is user-friendly. Heroku also offers a lot of flexibility with a security network.

*Table 26 Database Management Software Comparison*

	<b>Firestore</b>	<b>Heroku</b>	<b>MongoDB</b>	<b>MySQL</b>
<b>Data Representation</b>	JOSN objects	PostgreSQL	JSON documents	Tables and rows
<b>Query language</b>	NoSQL	SQL and NoSQL	JavaScript	SQL
<b>Ideal use</b>	Manage backend infrastructure, production ready environment, NoSQL easy to use interface.	Higher level of flexibility, real-time logs, and NoSQL and SQL databases.	Unstructured non-relational rapid growth database	Traditionally structured relational database
<b>Data security</b>	Strong	Strong	Weak ~ normal	Strong
<b>Cost</b>	\$0	\$0/\$7/\$25 a month option	\$0	\$0
<b>Chosen Database Management Software</b>				

#### 4.18 Analog Discovery 2

The Analog Discovery 2 was provided by the ECE department. It will have many uses in our project to test the various components.

- Analog Discovery 2, including the following:
- One regular-sized project box
- One USB A to micro-B programming cable
- One 2x15 flywire signal cable assembly

- 5-pack of 6-pin male headers
- One ferrite cable snap-on
- 1 pack of Mini Grabbers with Leads (5-Pack)
- 1 pack of Mini Grabber Test Clips (6-pack)
- 2 BNC to alligator Clip Cables
- 2 BNC to Mini Grabber Cables
- Analog Discovery 2x15 Ribbon Cable
- Solderless Breadboard Kit: Large
- BNC Adapter
- Breadboard Adapter
- Breadboard Breakout
- Impedance Analyzer
- BNC Oscilloscope x1/x10 Probes (Pair)
- Project Box: Jumbo-sized

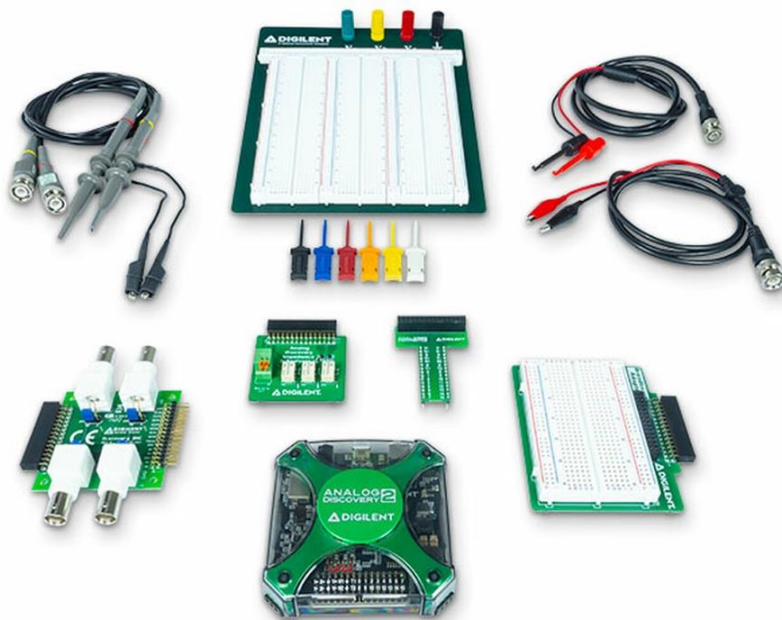

*Figure 45 Analog Discovery 2*

The WaveForms computer program was downloaded in order to use the Analog discovery 2.

The waveforms app has the functionality to perform the following functions:

- Oscilloscope
- Waveform Generator
- Power Supplies
- Voltmeter
- Data Logger
- Logic Analyzer
- Pattern Generator

- Static I/O
- Spectrum Analyzer
- Network Analyzer
- Impedance Analyzer
- Protocol Analyzer

The schematic for the analog discovery 2 will be used to properly hook up our circuits with the system. It is referenced in Appendix C.

This system will be an important of our aspect of optical demonstration this semester, as well as testing our parts as our project progresses.

## 5.0 Design

This section, the OptoSmart Pet Feeder team will describe the parts chosen based on the research done in section 0. Each part has been decided based on the best fit for our OptoSmart pet feeder.

Our design will be integrated together resemble the concept diagram shown in Figure 46. The sections below will give an in depth look at why the team decided to choose the parts from section 5 had how each system will function to allow the pet feeder to work.

An outline of this section includes (in this order):

- The Requirement Specifications
- A block diagram outlining the role of each team member
- The Bowl and Lid System Design
- PCB Design
- The Pet Collar Tag System Design
- Software Design
- Food Dispenser Design
- Microcontroller Design
- Microprocessor Design



*Figure 46 Opto-Smart Pet Bowl IR LED Layout*



*Figure 47 Opto-Smart Pet Bowl Photodiode View*

## **5.1 Bowl and Lid System Design**

The bowl and lid system will play an integral role in the overall design of the OptoSmart Pet feeder. This system consists of a semicircular plastic lid that sits over the top of the pet's food bowl and the food dispenser, the lid motor, the pet detection system (IR LEDs and Photodiodes), and the bowl. All these components are discussed in the section below.

### **5.1.1 IR LED Design**

As a part of the pet detection system for the OptoSmart Pet Feeder, the Infrared LED will be located above the bowl and the lid to the bowl. These will emit light while the system detects a specific-colored pet tag and will continue to stay on until the feeding time is over. These LEDs will function alongside the Photodiodes to detect the pets head and to tell the system when to open and close the lid.

The LEDs that were chosen will be invisible to the pet and the user but are close enough to the visible spectrum that they can be seen with a conventional cell phone camera. This will add sense of ease to the customer giving them comfort that the device is functioning properly.

The LEDs will be placed far enough away from the food that they will never intentionally encounter excessive foreign debris such as pet food crumbs or shed fur but will be close enough that there will be no problem detecting the pets head no matter the breed or size. The LEDs will also be protected by a thin plastic screen to further reduce any chance of being blocked out by foreign material.



### **5.1.2 Photodiode Design**

The second part of the pet detection system is the photodiode. For the OptoSmart Pet feeder, multiple photodiodes will be strategically placed above the pet bowl and the lid system, so they absorb the maximum amount of light from the IR LED.

The photodiodes will be placed in a horizontal line opposite the LEDs, this way as much of the light will make it through the system while the pet is not present and will receive the lowest input of light while the pet is present to ensure a clear signal.

As mentioned in section 0, the photodiode that was chosen (BPV23FL, specific component information can be found in section 4.3.2.2). The current that is generated from the photodiode will be sent to the microcontroller that is located inside of the housing of the OptoSmart Pet feeder. A predetermined on average and off average will determine whether the lid would remain open or should be shut.

### **5.1.3 Lid Motor Design**

The lid for the OptoSmart Pet Feeder must reliably open and close. To achieve this, a high-quality motor was chosen so that this product can perform its task correctly every time. The motor will be placed in an inconspicuous location on the device that will be out of sight of the pet and the end user.

The motor will be placed above the dispenser spout and will use a metal worm gear to move the lid up and down and will do this in an inconspicuous manner. The motor that was chosen was discussed in section 4.1.2.1.

Through research, the chosen motor was found to work with both the raspberry pi that the OptoSmart Pet Feeder team is using along with the Arduino used that integrates the motor system with the logic board (microcontroller).

## **5.2 PCB Design**

The PCB that will be developed for the OptoSmart Pet Feeder will be implemented within the collar that the pet will wear. This PCB will be created to have a battery powered LED that can be switched on and off by the user. For the PCB to fit within the collar housing that will be constructed, we will use Eagle to develop a PCB board layout with all the necessary components.

Before the board layout is created, we will form and test a simulated version of the circuit schematic that will be utilized on the PCB. Below are the detailed steps in completing the simulation and PCB development of the pet collar PCB.

### 5.2.1 PCB Circuit Simulation

Once the colored LEDs (red, green, and blue) are selected, we can then simulate and design a circuit that will be used to power these LEDs within the pet collar system. The basic design of this circuit will utilize the power from a battery to light up an LED whenever the switch is set into the closed position (battery is physically connected to the circuit).

Three separate circuit designs will have to be created to account for each color of LED that will be implemented into the collar PCB design. To simulate and test these circuits before they can accurately be transferred to a PCB, we will use the Mutlism Live simulation software. Below are the three circuit diagrams that were developed and simulated using Multisim Live:

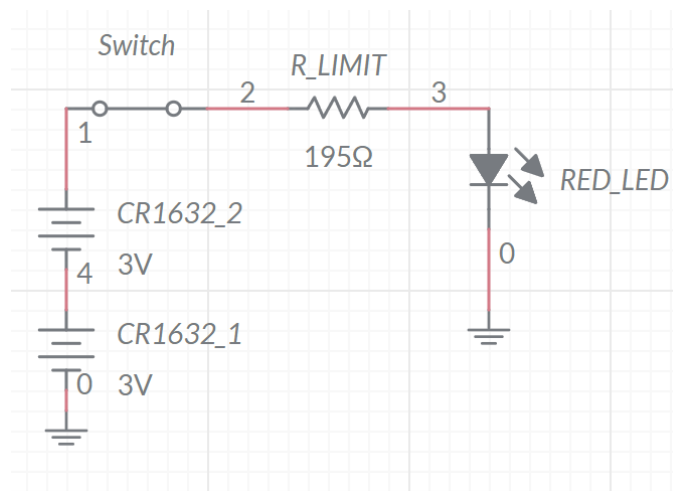

*Figure 48 Circuit Schematic for Red LED*

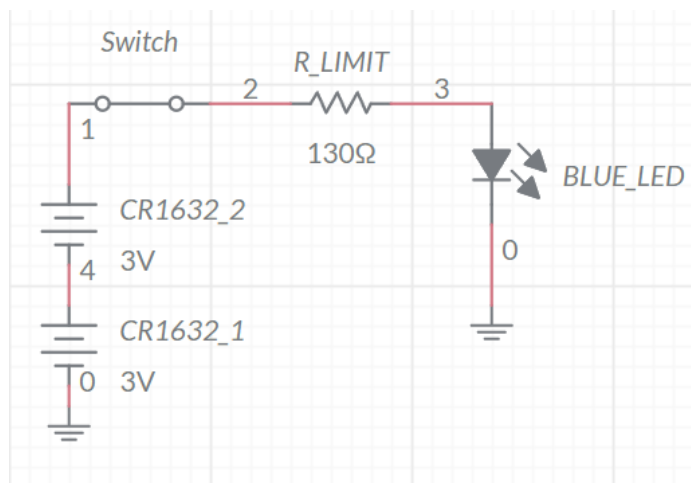

*Figure 49 Circuit Schematic for Blue LED*

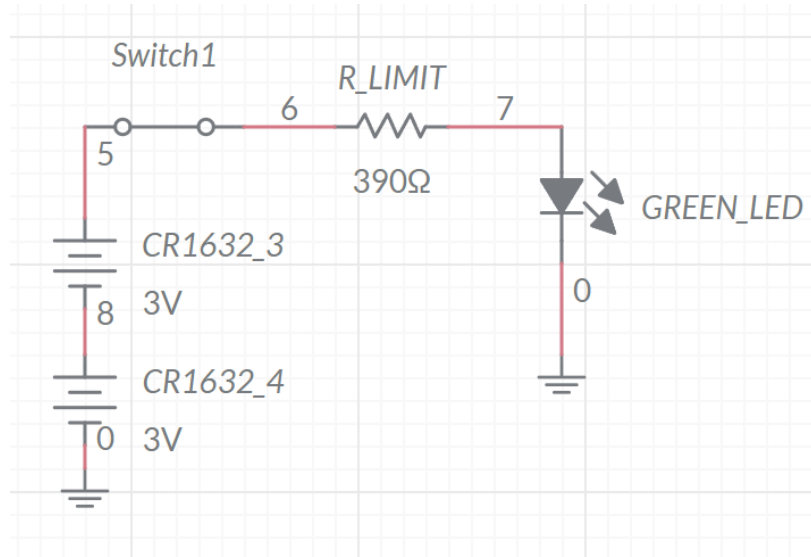

Figure 50 Circuit Schematic for Green LED

Table 27 Limiting Resistor Calculations

Circuit	Red LED	Blue LED	Green LED
Voltage across limiting resistor (V)	3.9	2.6	3.9
Operating Current (mA)	20	20	10
Calculated limiting resistance ( $\Omega$ )	195	130	390

The red, blue, and green LEDs simulated in the circuits above will correspond as closely as possible to the LED's selected in Tables 8, 9, and 10. The SPICE models used for these LEDs will not be able to match the exact specifications of each LED but will provide a close approximation to how the LED will behave with the rest of the components in the circuit.

We chose to add a second CR1632 battery in series with the initial battery to provide a greater voltage to the circuit. This increase in input voltage allows the limiting resistor value to be large enough to prevent too much current from flowing through the circuit. Also, the addition of a second battery will provide extra capacity that will result in an LED that can be powered on for a longer amount of time.

To determine the values of the limiting resistors we will use Ohm's Law ( $V=IR$ ) and substitute the operating current for  $I$  and voltage across the limiting resistor for  $V$ . Solving for  $R$  will result in the minimum resistor value needed to maintain the LED in an ON state with the proper operating current.

However, the components used in Multisim Live do not contain any tolerances or internal resistances that will be encountered when constructing the physical circuit. This means that the values found in Multisim Live will only be approximations, and minor adjustments may have to be made when putting together the PCB during our design. The table above highlights the calculations for the limiting resistor to allow for the proper voltage drop across the LED (determined by the typical forward voltage of the LED).

Now that the minimum limiting resistors for all three LED circuits have been calculated, the circuits can be simulated, and the voltage and current values can be verified to solidify the final circuit design that will be implemented within the PCB.

Using the voltmeter/ammeter tool on Multisim Live, the voltage and current data can be obtained from the input and at the node in between the resistor and LED. Below are the three simulated circuits with their appropriate voltage and current data shown on the schematic. This data will then be tabulated for convenience and ease of use.

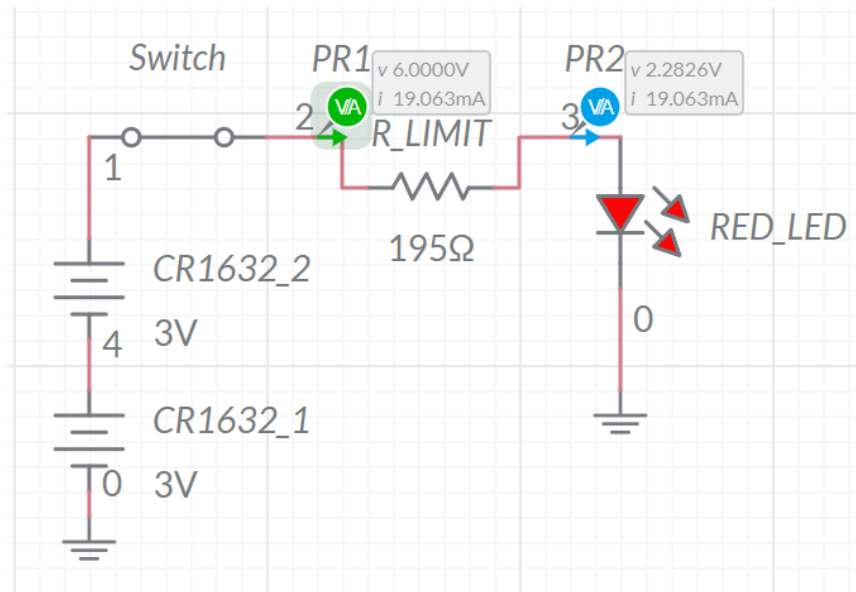

Figure 51 Circuit Schematic with Values for Red LED

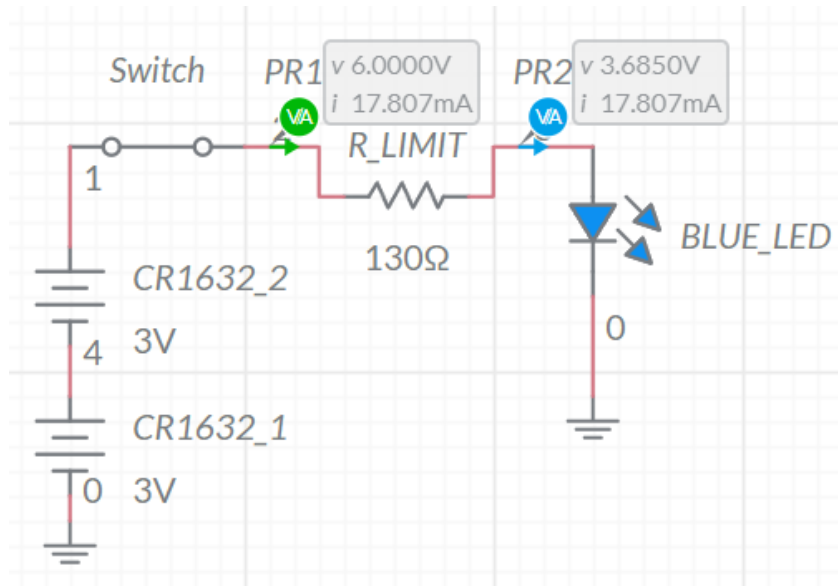

Figure 52 Circuit Schematic with Values for Blue LED

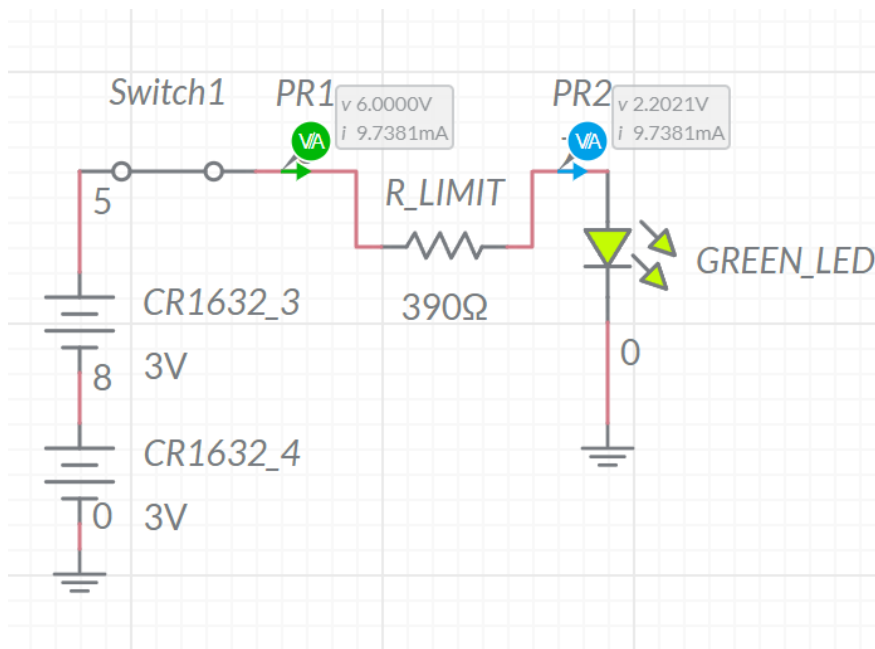

Figure 53 Circuit Schematic with Values for Green LED

From observation of the prior circuit diagrams, we can construct the following table of information values filled with the voltage and current data obtained from the simulations. This table will compare the simulated voltage and current values to the expected (theoretical) voltage and current values to ensure a proper simulation was conducted.

*Table 28 Simulated Circuit Values*

<b>Circuit</b>	<b>Red LED</b>	<b>Blue LED</b>	<b>Green LED</b>
<b>Simulated Forward Voltage (V)</b>	2.28	3.69	2.2
<b>Theoretical Forward Voltage (V)</b>	2.2	3.2-3.8	2.1
<b>Operating Current (mA)</b>	19.06	17.81	9.74
<b>Theoretical Operating Current (mA)</b>	20	20	10

The table above details the accuracy of the voltage across and current through the LED components within the simulated circuit compared to the values found in the respective LED datasheets.

It is apparent that the simulated values are close to the expected values, and these slight errors can be attributed to the simulation not considering all non-ideal parameters that are affected when the physical circuit is built.

Additionally, we made sure that all the simulated operating currents resulted in a value less than or equal to the rated operating current. This was to ensure that the LED would receive enough current to shine bright enough, but not receive an amount of current that would unnecessarily drain more power from the battery without proving any visible increase in brightness.

### **5.2.2 Eagle PCB Development**

Once the circuit simulations are completed and verified, the next step is to design a PCB board layout using corresponding physical component footprints and measurements. The PCB schematic and board design process will be shown for the Red LED circuit, since the circuits for the other two-colored LED's (Blue and Green) will be identical except for the LED chosen and the resistor value used.

The PCB layout will not change based on which color of LED is used, since all the collars made for the OptoSmart Pet Feeder will be the same size and shape. The Eagle schematic (following the design shown in the Multisim Live simulations above) along with component selection is shown below.

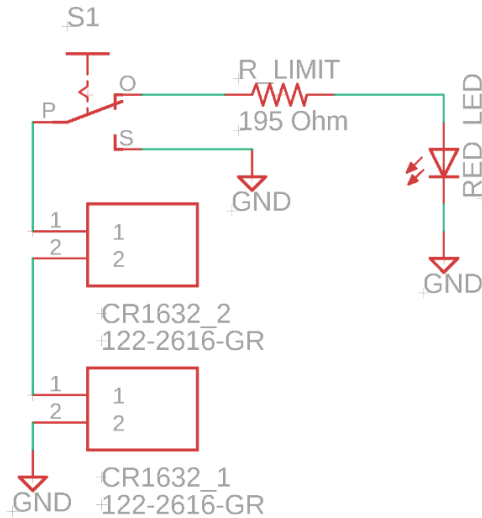

*Figure 54 Collar PCB Schematic*

The above figure shows the schematic that will be used for the PCB in the pet collar. There are two batteries in series used to provide enough voltage for the LED to turn on under the specified operating conditions.

A switch is used to either connect or disconnect the batteries from the rest of the circuit (corresponds to turning the LED on or off). The limiting resistor (value of 195  $\Omega$  calculated previously) is connected in series to both the batteries and the LED. The following table details the exact component selection that was used to generate the PCB schematic

*Table 29 Component Selection for Collar PCB*

Symbol	Value	Part Number	Type
<b>R_LIMIT</b>	195 $\Omega$	-	0805 Resistor
<b>RED_LED</b>	-	RL5-R8030	5mm LED
<b>S1</b>	-	EG1218	SPDT Switch
<b>CR1632</b>	-	CR1632	Coin cell Battery

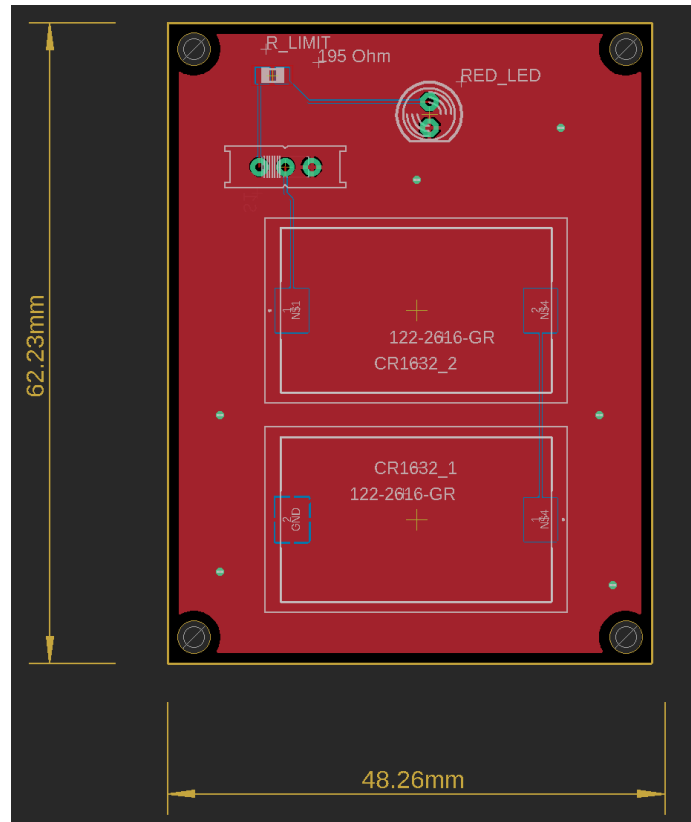

*Figure 55 Collar PCB Board Layout*

After the schematic is created, the PCB board layout can be developed as shown above. The size of the board was made to be less than 5 square inches (127 square millimeters), and this can be achieved since all the components were selected earlier based on the size constraint in mind.

The above PCB layout was developed from the schematic in Figure 49, we chose to use two layers for this PCB to help simplify the design and ensure proper grounding. Both the top and bottom layers of this PCB are assigned as ground, so there is less room for instability within the PCB. Additionally, using only two layers for this PCB results in a cheaper overall design without sacrificing any stability.

All components were placed on the board to ensure minimum trace length, and the batteries were both placed next to each other for a cleaner design. The switch is placed on the bottom layer of the PCB (back of the PCB) for a gap to be present between the LED and the lens that will be placed on the PCB housing.

Since we have not finalized every section of design for the Opto-Smart Pet Feeder, we will first test that the above circuit will work properly using the components and a breadboard. Once testing is complete, we will be able to finalize our PCB designs and implement it within the entire Opto-Smart Pet Feeder system.



### 5.2.3 Additional PCB Insights

In addition to the PCB that developed for the pet collar of the Opto-Smart Pet Feeder, there may be additional modules that may have to be created using a PCB to aid in the design of the rest of the physical system.

Since thorough testing has not been completed yet, it is uncertain if these modules will need to be implemented. The first additional module that will be presented is a 3.3V to 5V circuit that will be able to take an input voltage between 2.4 V and 3.3 V and output a constant 5V source.

This type of circuit may be useful if we plan to use batteries to power a section of the device that is separate from the battery powered PCBs on the pet collar. Below is one design of a 3.3V to 5V converter that utilizes a TI component referred to as TPS61241YFFR.

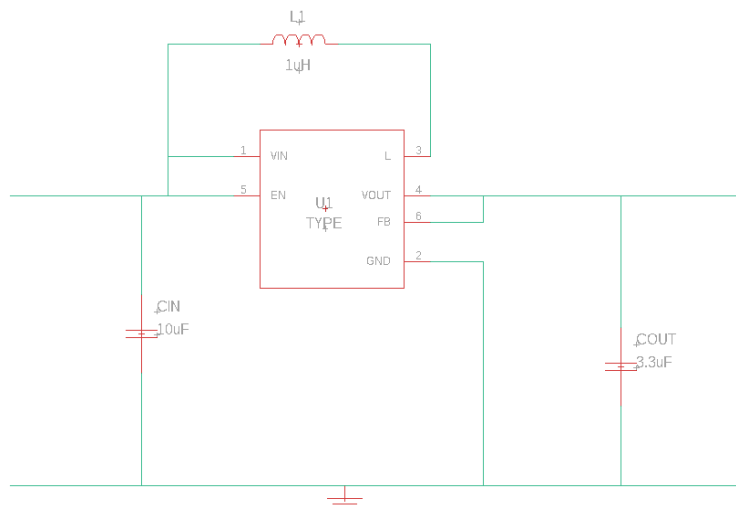

Figure 56 3.3V to 5V Converter Schematic

### 5.3 Pet Collar Tag System Design

The pet collar tag will be a device that accompanies the Opto-Smart Pet feeder that the pet will always wear so that the camera system will be able to detect the pet. The tag itself will be a 3D printed plastic shell that will be small enough not to get in the way of the pet's day-to-day functions.

The plastic shell will also protect the LEDs and the onboard PCB components from environmental hazards such as liquids and dirt. Another feature that will be included with the collar tag is an easy way to change the battery so the device can continue to function.

To sum up, the Opto-Smart Pet Feeder collar tag will consist of a plastic housing, a red, green, or blue LED (The product will come with 3 separate collar tags each with a different colored LED), and a planoconvex lens. The individual components included will be discussed below.

### **5.3.1 LED Design**

After the completion of the research done in sections 5.2 and 5.7, we will be using two different types of LEDs for this project. For the collar tag the Opto-Smart Pet Feeder team has decided to use three different colored LEDs that emit light in the visible spectrum.

For the pet detection sensor, the team has elected to use LEDs in the IR spectrum. The design of the color LED will be elaborated upon below (The IR LED design information can be found in section 5.1.1).

#### **5.3.1.1 Color LED Design**

For the pet collar tag the Opto-Smart Pet Feeder team has decided to use red, green, and blue LEDs (the research associated with the chosen LEDs can be found in section 5.2.1) These LEDs will be used to help identify the pet wearing the collar and will work in tandem with the camera system.

The LED will be powered with a CR1632 button cell battery that was discussed in section 5.4.1.2. Each LED has a different forward voltage and the voltage going to the LEDs must be adjusted for the LED being considered, this can be accomplished by adding resistors in series to the LED to vary the voltage for each of the chosen LEDs.

The LEDs chosen for this project all have a minimum viewing angle of 30 degrees, this value was decided from the Zemax calculations shown in section 5.6.2.1 for the lens to diffuse the light properly the LED must have an angle of at least 30 degrees with an optimum viewing of 40 degrees for all wavelengths chosen.

The housing for the LED must also have an air gap between 15 and 20 mm in order for the light being emitted from the LED to disperse properly these calculations can be seen in the Zemax diagram in section 5.6.2.1 and the equations the Opto-Smart Pet Feeder used in section 5.6.1. The lens also adds a small amount of weather resistance to the electrical components including the LED.

### **5.3.2 Lens Design**

The Opto-Smart Pet Feeder's collar tag will contain a 1" planoconvex lens that has a focal length of 25mm (the Zemax calculations for the chosen lens can be found in section 4.6.2.1). The lens chosen will be 15 – 20mm away from the LED so that the light being emitted from the LED diffuses with maximum effect.

From calculations completed in section 4.6.2.1, all wavelengths that are used in the collar tag will work efficiently at the same distance in each tag (this means that red and green diffused spot size will be very similar with the lens placed at the same distance for both LEDs, this will make the assembly of the collar tags much easier).

The size of the lens also had to be large enough that it would not interfere with the LED and act as an aperture limiting the light of the LED. With the distance of the LED being considered, the closest matching lens that was commercially available had a 1” diameter.

#### **5.4 Camera System Design**

After the completion of the research done in Section 4.8, it was found that the BBTO OV5647 is the best fit for our design. It is cost efficient as it comes in pack of two for only \$10.39. It has a CSI port, so it can integrate into the Raspberry Pi at the port that was designed for cameras.

It is tied as the highest resolution from our comparison. It is compact and will be able to be easily integrated into our design. For these reasons the BBTO OV5647 will be integrated into our Opto-Smart pet feeder.

#### **5.5 Food Dispenser Design**

The food dispenser design will make use of gravity to allow the food to fall from the storage container into the bowl. A rotating plate (spun by the brushless DC motor) with cutouts will be used to either hold the food in place (plate is blocking the opening of the storage container) or to allow the food to flow from the container into the bowl (cutout lets the food fall through the plate when the cutout is oriented underneath the storage container). An example of a type of rotating plate that will be used in the design is shown in Figure 64



*Figure 57 Physical Concept of Dispensing Plate*

When it is time for the pet to eat and the camera detects the correct color LED from the color of the pet collar, the DC motor will spin the dispensing plate, allowing the food to fall into the bowl when the cutout is below the funnel where the food can drop through.

To test and optimize the speed at which the food is dispensed and the amount of food that is dispensed, we will implement a software timer that is synchronized with the spinning of the motor. The software will measure the rpm of the motor and run the motor for a set amount of time. We can then measure the amount of food that was dispensed during the time set by the software.

Using the obtained approximate number for the volume of food dispensed per second, the amount of time that the motor must be activated (to deliver the correct volume of food output) for can be permanently adjusted in the software.

## **5.6 Microcontroller Design**

The microcontroller that was selected to be used within our project after analyzing the information from the research section was the Arduino uno. The Arduino uno is a standalone microcontroller that can regulate input voltages as well as power and control motors, LEDs, photodiodes, and other various sensors.

Since our team will make use of a microprocessor, the Arduino architecture will be able to interface more simply with a microprocessor to transmit crucial image data. Additionally, Python can be used to program code for the Arduino as well as the Raspberry Pi 4, which makes synergy between the two devices much more seamless.

The Arduino also comes equipped with a 9 V to 3.3 V voltage regulator, which will be able to be utilized when connecting to the Raspberry Pi 4 (Raspberry Pi 4 works off a 3.3 V basis). Additionally, the Arduino can be powered by a 9 V adapter which can also allow the Arduino to power the Raspberry Pi 4 as well through a USB connection. The main use of this microcontroller in the Opto-Smart Pet Feeder will be to activate motors in response to image data that will be processed by the Raspberry Pi 4.

The Arduino will be programmed to activate the motors that open/close the lid and dispense the food whenever the Raspberry Pi 4 sends the data corresponding to the collar LED being recognized by the camera module. The images below show the two different ways of interfacing the Arduino with the Raspberry PI 4 that may be used in our design. Figure 58 details how the Arduino can be directly interfaced through USB connection on the Raspberry Pi, while Figure 59 indicates that the two devices can also be connected through GPIO pins (routed through an extra PCB with pin headers).

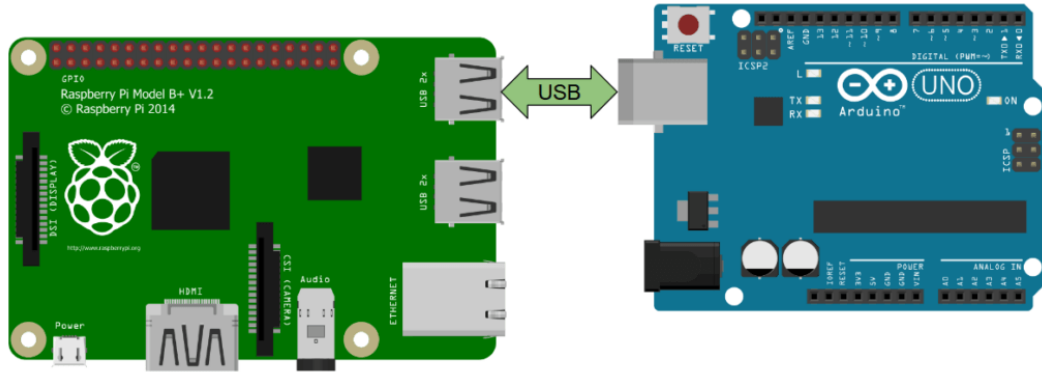
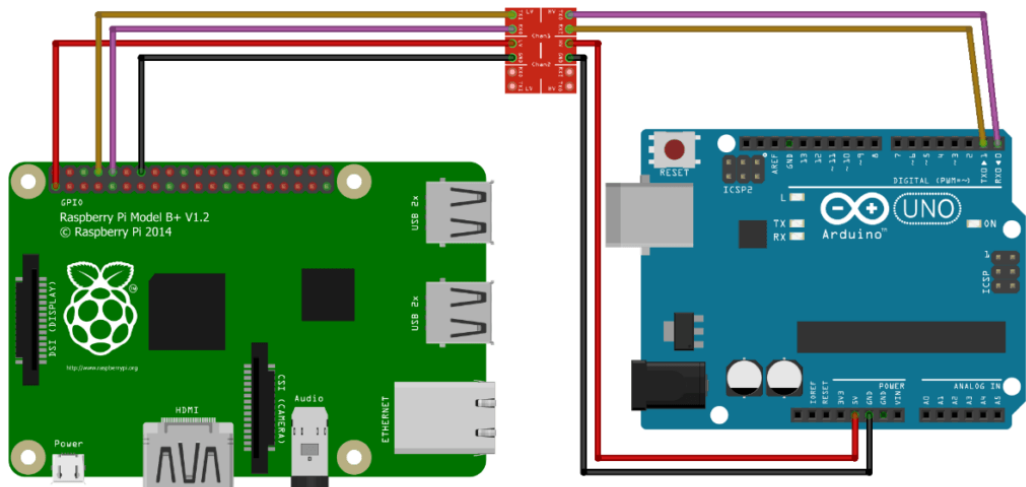

Figure 58 Arduino Uno and Raspberry Pi 4 Connection through USB (Courtesy of Robotics Back-End)



fritzing

Figure 59 Arduino Uno and Raspberry Pi 4 Connection through GPIO Pins (Courtesy of Robotics Back-End)

## 5.7 Microprocessor Design

After completing the research portion of the potential microprocessors to use for our project, it was a no brainer to go with the Raspberry Pi 4.

The Raspberry Pi 4 microprocessor has all the necessary capabilities and functionality to have our device reach its fullest potential. With the Raspberry Pi 4 microprocessor basically being a microcomputer, the Raspberry Pi 4 can and will for our case replace a traditional desktop within the system as the microprocessor takes in all inputs related to a traditional desktop such as a power supply, HDMI, keyboard, and mouse, with proper WIFI, and ethernet control making the possibilities of the Raspberry Pi 4 practically endless.

Specifically for our project, the Raspberry Pi 4 will act as the brains of our device operation allowing the system to dissect logic with the implemented Python code, especially when we plug in a compatible camera input into the Raspberry Pi 4 and allow for the camera to detect the LED light attached to the collar of the pet to further determine whether or not the color of the LED light is correct (true), and ultimately open the lid properly for the animal to eat the food.

The Raspberry Pi 4 can also potentially display the logic being handled internally with digital machine language to a display connected to the HDMI for the user to see externally while in work.

The CanaKit shown in Figure 60 was purchased on Amazon for \$119.99. It includes the Raspberry Pi 4 4GB model B with 1.5 GHz 64-bit quad-core CPU and 4 GHZ of Ram. It comes with a 32GB Samsung EVO+ micro-SD Card. It also comes with a case that has a fan integrated to help regulate the temperature as well as help keep the system functioning efficiently. It comes with the 3.5A USB-C power supply as well as heat sinks, a 6-foot micro-HDMI to HDMI cable, and a power switch. This kit comes with a wide range of accessories we need in addition to the Raspberry Pi 4.



*Figure 60 CanaKit Raspberry Pi 4 4GB Starter PRO Kit*

## 5.8 Overall Design Schematics

Once the pet collar PCB is designed and the microcontroller and microprocessor are decided on, an overall project schematic can be implemented to display the relevant ports and connections that will be required and utilized by the Opto-Smart Pet Feeder.

Since we will be making use of the Arduino Uno as well as the Raspberry Pi 4 to control our complete device, the schematic designs for both devices will need to be implemented. The schematics for our project will be made mostly in EAGLE (except for the Raspberry Pi 4, since it will be mostly a standalone device).

All the parts that are added to the EAGLE schematic will need a proper footprint and symbol, and all the required footprints (for the Arduino Uno microcontroller) are supplied by Arduino for use with EAGLE. Below is the EAGLE schematic design for the overall project schematic that will be used for the Opto-Smart Pet Feeder. This schematic design contains all the pins and connections for the Arduino Uno PCB as well as the addition of the separate pet collar PCB section that was added to the top left of the schematic.

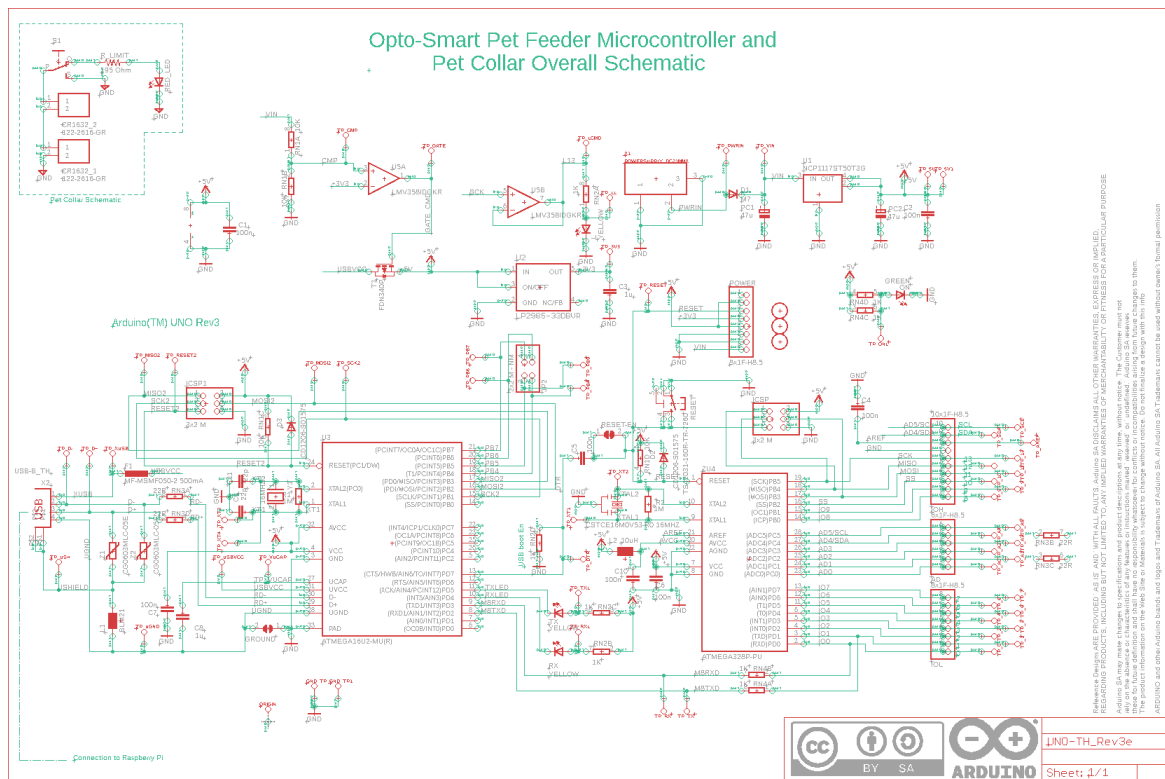

Figure 61 Opto-Smart Pet Feeder Overall Microcontroller/Pet Collar Schematic

Additionally, the schematic designs for the Raspberry Pi 4 will be needed as well. Since there will not be any alteration of the original PCB that the Raspberry Pi 4 is already a part of, the EAGLE schematic file is not required.

Instead, Raspberry Pi 4 contains their own schematic documentation that will be followed when developing our device. All the external ports and pins are highlighted in the schematic overview, and the two main parts of the schematic that are relevant to the Opto-Smart Pet Feeder are the camera module and USB connection module. The relevant assortment of Raspberry Pi 4 schematics is shown below.

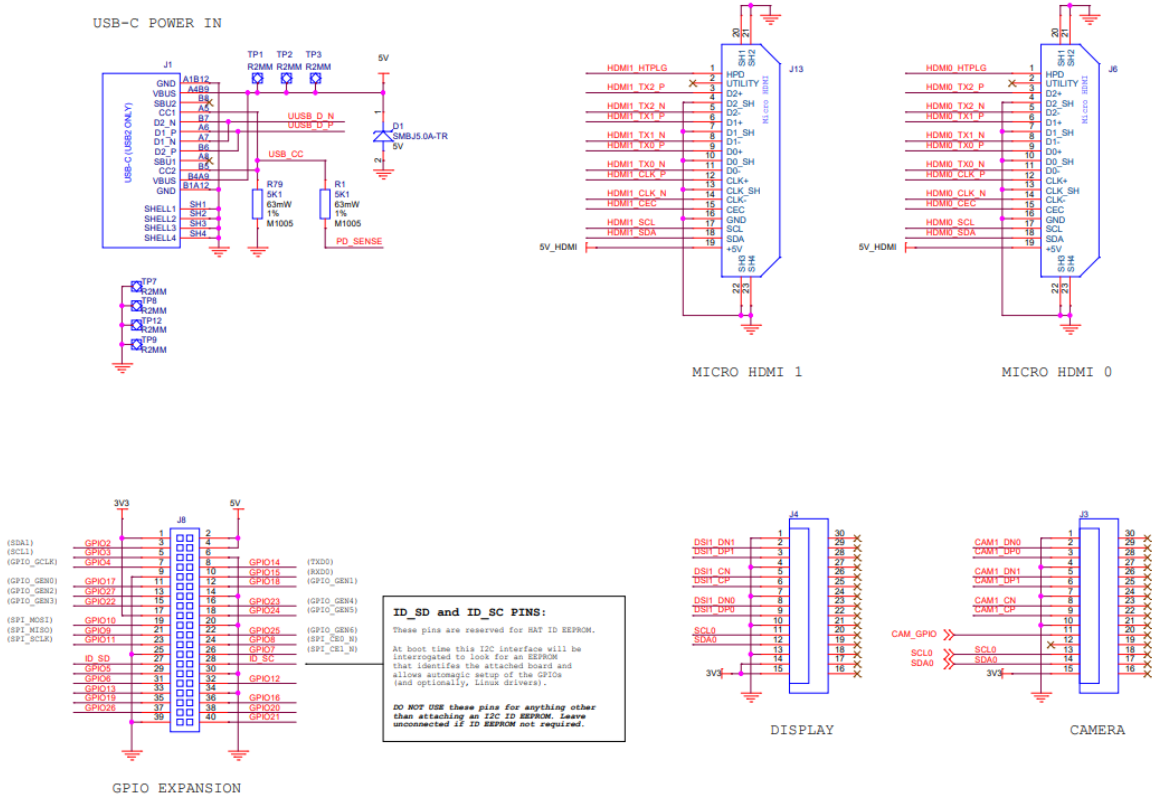

Figure 62 Raspberry Pi 4 Module Schematics (Courtesy of Raspberry Pi)

## 5.9 System Software Design

After completing the research portion of the potential system software programs to use for our project, we collectively determined to use Python as the main coding language for our microprocessor as the Raspberry Pi 4 heavily supports the Python programming language to operate any sort of customized functionality.

Python offers a much simpler syntax in comparison to other older programming languages such as C, and C++, where in languages such as C, and C++, the formatting syntax can be very tricky and confusing as for most users having to iteratively define every method, and function used while having its structure intact as well. Debugging can also be very tough to handle in languages such as C, and C++ as the error messages are 9 out of 10 times unclear to what they meant with segmentation fault occurring every time you don't allocate space for memory,

However, in Python, debugging can be done as easy as with a push of a button with clear error messages, single definition of variables, and never running out of memory with automatic dynamic allocation. Python also offers an abundance of libraries for anyone to reference in the source code which allows for a greater capability to accomplish any



difficult logic/algorithms that may be even more difficult to program in other object-oriented programming languages such as Java.

This Python code will generally be written, edited, compiled, debugged, and ran in Visual Studio Code for our system software development which is regarded as one of the best code editors available for Python with its redefined and optimized building structure for editing, and a state-of-the-art debugging system especially molded for the modern web, cloud, and mobile applications implementation if the system is later needed to communicate with such functions. Also, the program being free to all users is a plus.

The highlighting capability that can be optionally installed into the program externally is very useful with colorful hints for organization of the code, and error hint messages that is provided before even compiling the code is a nice add-on.

Other code editors such as Atom, and Repl.it, can get the job done, however, the efficiency of coding on Visual Studio Code is unmatched. Even being able share the code with others is difficult with Atom, and compiling multiple files is difficult on Repl.it, but Visual Studio Code can and will accomplish the best of both worlds. Visual Studio Code also has a compiler terminal built into the program, having access to it while editing on the same software.

With Visual Studio Code having the ability to directly connect with GitHub allows for the perfect Segway of describing the correct implementation and use of the software GitHub into our group project. The organizational standard and structural definition that GitHub provides allows for collaborative programming work to be done by the author and easily have him/her post online to the group GitHub account and allow secure access to every member of the group who might needs to push or pull the code to their project's code from online to their machine and vice versa is very useful in the modern era of collaborative programming.

Like mentioned previously not only is the access to the collaborative work efficient, however, it adds organization and structure to the created programming code which is always effective and professional to have especially better than having all the code written to be jumbled up on some file stored locally on your storage drive somewhere.

## **5.10 Web Application Design**

To store on a remote server and delivered data over the Internet through a browser interface, a web application communication is needed for our project. A web application FERN stack structural design will be used in our web application development.

These web application UI components are a useful functional tool to enhance the step application of the project, which in hand complements one another highly efficiently to properly create a fully working and functional web application to post and host via the server to the internet for all to use. Specifically, a FERN stack (Firebase Express React Node), is where the traditional Angular.js frontend framework and MongoDB document

database being replaced with React.js, and Firebase respectively. Other variants such as MERN, and MEAN stacks do exist and can be used for any instances as well, just depending on the preferred frontend JavaScript framework, and document database.

The top tier of the FERN stack is React.js, the declarative JavaScript library framework for creating dynamic client-side user interface applications in HTML.

React allows for the developing users to code their specific UI components inside of JavaScript to create an overall visually appealing framework for the web application. Which essentially means that react allows developers to build up complex interfaces through simple Components, connect them to data on your backend server, and render them as HTML. React's strong suit is handling stateful, data-driven interfaces with minimal code and minimal pain, and the containment of having all the bells and whistles developers expect from a modern web framework: great support for forms, error handling, events, lists, etc. has a mainstream and popular appeal for all to use.

The next level down is the Express.js being inside of the Node.js in term of hosting server-side of the web application. Express.js has powerful models for URL routing (matching an incoming URL with a server function), and handling HTTP requests and responses for efficiency.

Those functions in turn use the document database of the developer's choice (In our case Firebase) Node.js drivers, either via callbacks for using Promises, to access and update data in your document database.

Lastly, If the application requires any sort of data to be stored, Firebase can come into perfect use. As Firebase is a Google platform that gives you access to a bunch of developer tools, most notably their real-time, NoSQL database, which allows you to modify the database through their website, created and referenced in the developers React.js front end that can be sent to the Express.js server, where they can be processed and stored directly into the Firebase database for later retrieval.

The Fern Stack application will all come full circle and come together to create a fully functioning webpage that will ultimately be designed to fully control via the internet webpage application remotely as they connect and communicate with all the important key aspects of the functionality of the system itself. Some of the key functionality that can be controlled via the webpage will include the remote feeding, customized meals at a set point of time, as well as the amount of food dispensed to the pet, etc.

## **5.11 Mobile Application Design**

To establish a clean, seamless, user-friendly, and wireless functionality to the smart device for our project, a mobile application must be developed. The mobile application should use the back-end API to communicate with the server and serve the same functionality as the desktop web application. It's important to note that while the mobile application is not required to be cross-platform, it would be an efficient and effective feature to have for the product as the user of the mobile application would be able to easily utilize all the key

features accessible via their mobile device for a better overall remote communication experience between the product and the application.

Flutter will be used as the main open-source mobile SDK developer as the program is powerful, and uses modern framework built and developed by google to make mobile applications that were written by developers a “write once, run anywhere,” type of code via compiling your code down into a virtual machine that runs and renders the mobile application on whatever platform the user would like to use.

The tool is very developer friendly, runtime functional, and again powerful as well as it being creative and open-minded for developers to make unique user interfaces with.

The Flutter mobile application will be able to fully communicate with the built system being able to control all its functionality remotely via the mobile phone to be able to feed your pet at any time at the user’s discretion. Some of the key functionality that can be controlled via the mobile application will include the remote feeding, customized meals at a set point of time, as well as the amount of food dispensed to the pet, etc.

## **6.0 System Testing**

To test our design, we will compare the functionality of our working design with the objectives and project specifications discussed in the design specification.

A demonstration of the optical components functioning as intended will be outlined below. We will also discuss how our entire system will be tested to ensure it is working properly.

For the testing of our system, we will not be using a real dog. UCF does not allow non-service animal pets on campus, so we will be testing our design in alternative way. To demonstrate a working product, we will use our hands to bring the collar closer to the camera system, and to block the photodiodes from receiving a signal. This will further be outlined in the sections below.

### **6.1 Optical Demonstration**

The Opto-Smart Pet Feeder's optical design must be tested to ensure that this is a realistic product that has the potential to function. This demonstration is not to demonstrate a complete working product but to show that the optics that make this project work can function as intended. The systems being tested must also adhere to the design specifications listed in section 2.4.

The optical system for this design project consists of two separate parts: one is the camera system and the pet collar tag, and two is the pet detection system and the lid. Simply for proof of concept, the lid system will not be included in the optical demonstration due to its purely electro-mechanical nature, the complete collar tags will also be omitted from the demonstration since the concept we are trying to prove works is the led-camera relationship and how those components function.

#### **6.1.1 Optical Demonstration Components**

The following sections will explain the optical components that can be used to demonstrate our design process. In our demonstration we will be able to demonstrate how the Opto-Smart Pet Feeder will function. This will include both a camera system as well as the IR LED and photodiode demonstration.

##### **6.1.1.1 Camera System**

The first aspect of the optical demonstration will show how the colored LED responds to the camera system. For this, the camera must correctly detect three different colors: (red, green, blue). A neutral density filter may be used to help block out any unwanted light for this demonstration.

### 6.1.1.2 IR LED and Photodiode

The second aspect of a demonstration will focus on the pet detection system. The IR LEDs and the photodiodes will be mounted across from one another at a distance that will be similar to how they will be set up for the real product (10 inches). The output of the photodiodes will be connected to an oscilloscope which will display their voltage and can detect when there is a rise or drop in voltage.

Once the LEDs begin emitting light and the photodiodes display a voltage on the oscilloscope, an on reading will be taken. From there, the light coming from the LEDs will be blocked, and an off reading will be taken on the oscilloscope.

To make the demonstration more visual for an audience, a simulated lid will be used in the test. The representation of the lid could be a color changing on a computer screen or a light that is lit to signify the lid is closed and unlit while the lid is closed. Either way, the demonstration will display the main part of the Opto-Smart Pet Feeders optical system and prove that this is a realistic feature that can be employed for this project.

### 6.1.2 In Class Optical Demonstration

During our Optical Discussions demonstration, we were able to demonstrate our optical components and how we have worked towards getting them to function. We were able to test both the camera system as well as the IR LED portion of our system.

#### 6.1.2.1 Color LED and Camera System Demonstration

Using the Analog Discovery 2 we were able to provide power to our LEDs. The power provided to each LED is depicted in Table 30.

*Table 30 Optical Demonstration Color LED Voltages*

Color	Voltage Supplied
<b>Red</b>	2 V
<b>Green</b>	3V
<b>Blue</b>	2.5 V

A MacBook Air was used to download MATLAB as well as the MATLAB support package for USB cameras, Computer vision toolbox, and the image processing toolbox. The MacBook camera was used for the purposes of this experiment.

MATLAB code was researched and created to demonstrate how a digital filter can be used to split the LEDs color into green, blue, and red. This configuration is similar to how our final code will operate. The program will spit the colors and only look for the color programmed into the pet specific collar.

We also tested out the lens we chose for our design, the following will depict how each color was separated in the program as well as how the lens enhanced the color and light of each of the LEDs.

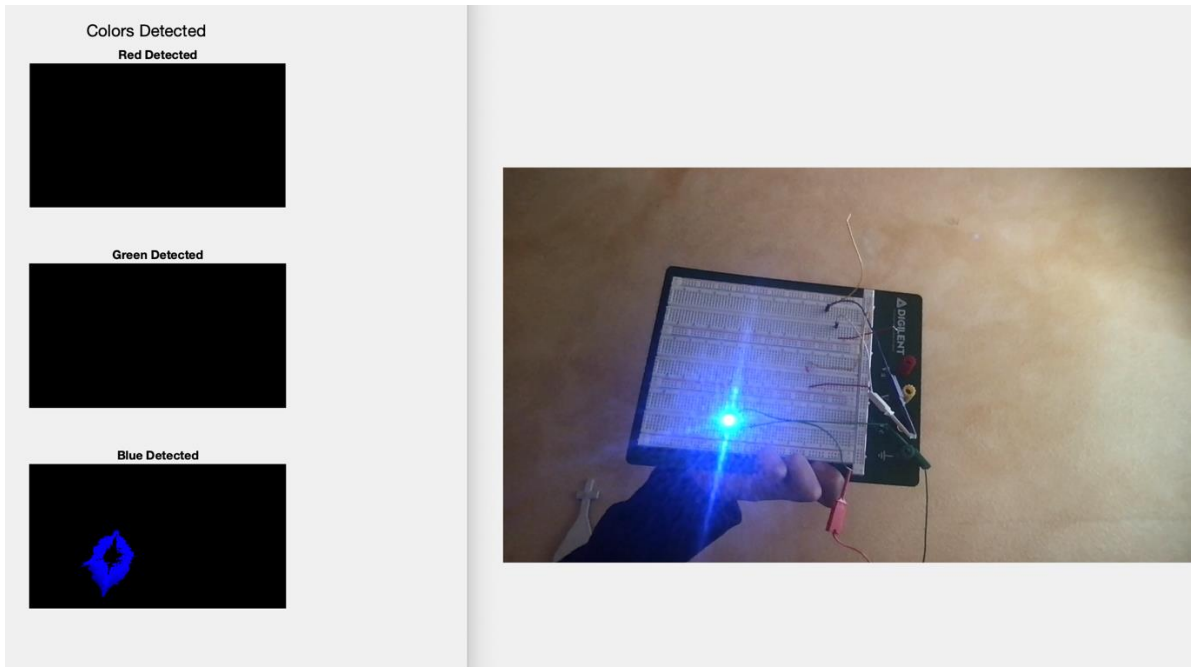

*Figure 63 Blue LED Optical Demonstration*

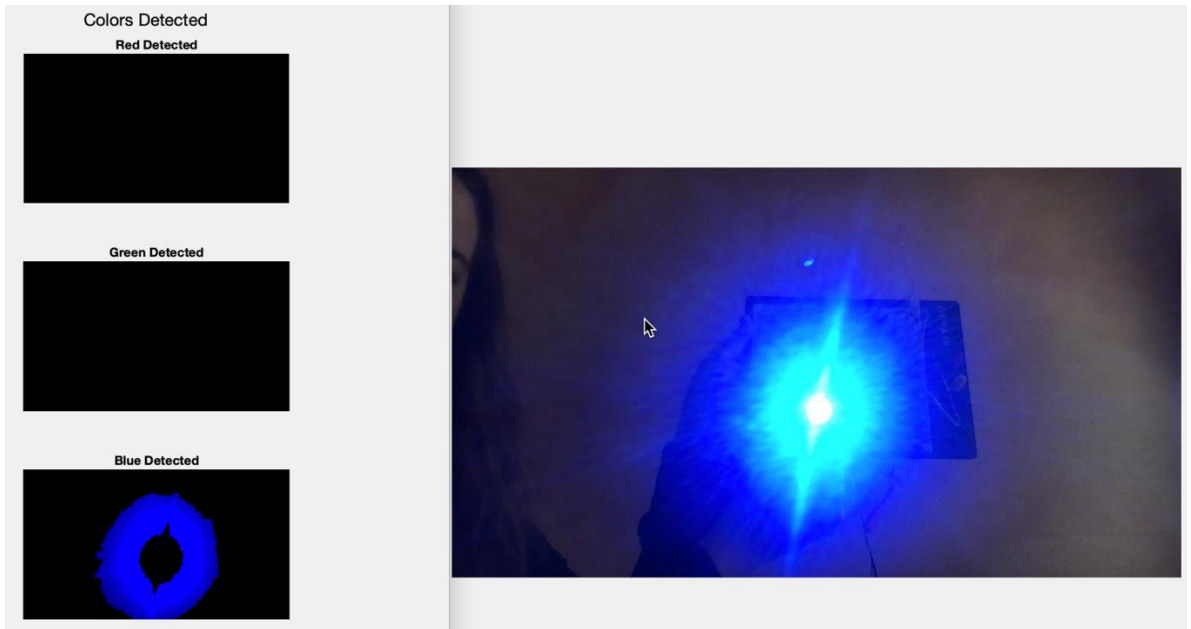

*Figure 64 Blue LED with Lens Optical Demonstration*

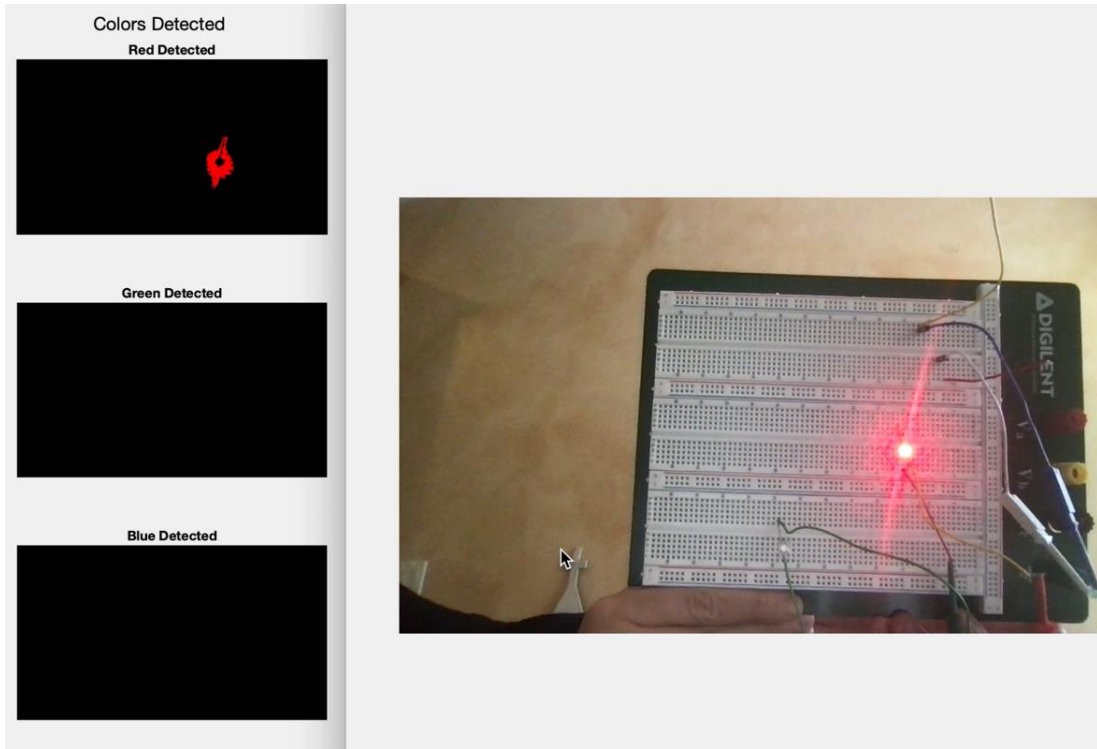

*Figure 65 Red LED Optical Demonstration*

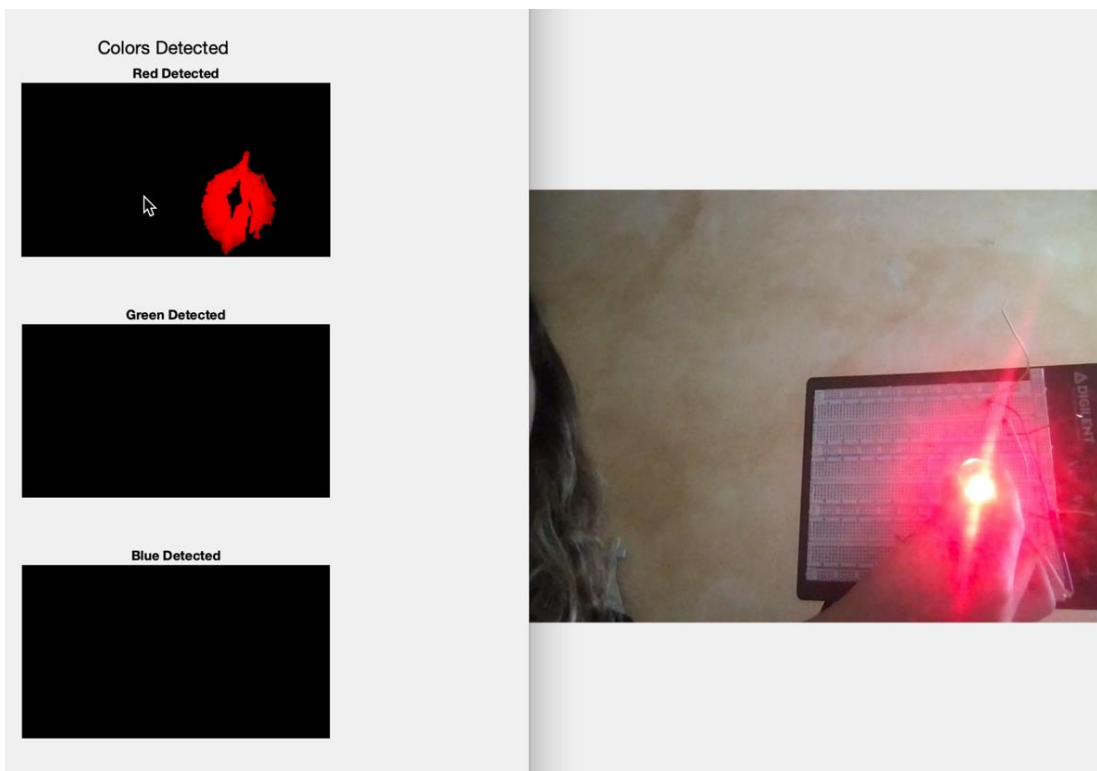

*Figure 66 Red LED with Lens Optical Demonstration*

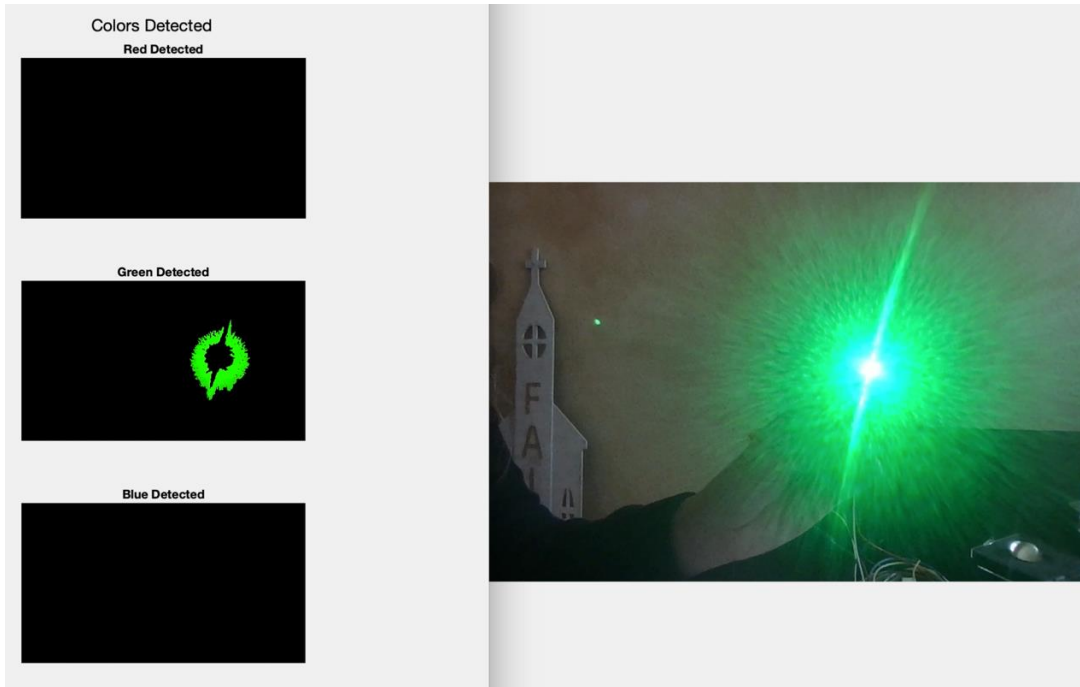

*Figure 67 Green LED Optical Demonstration*

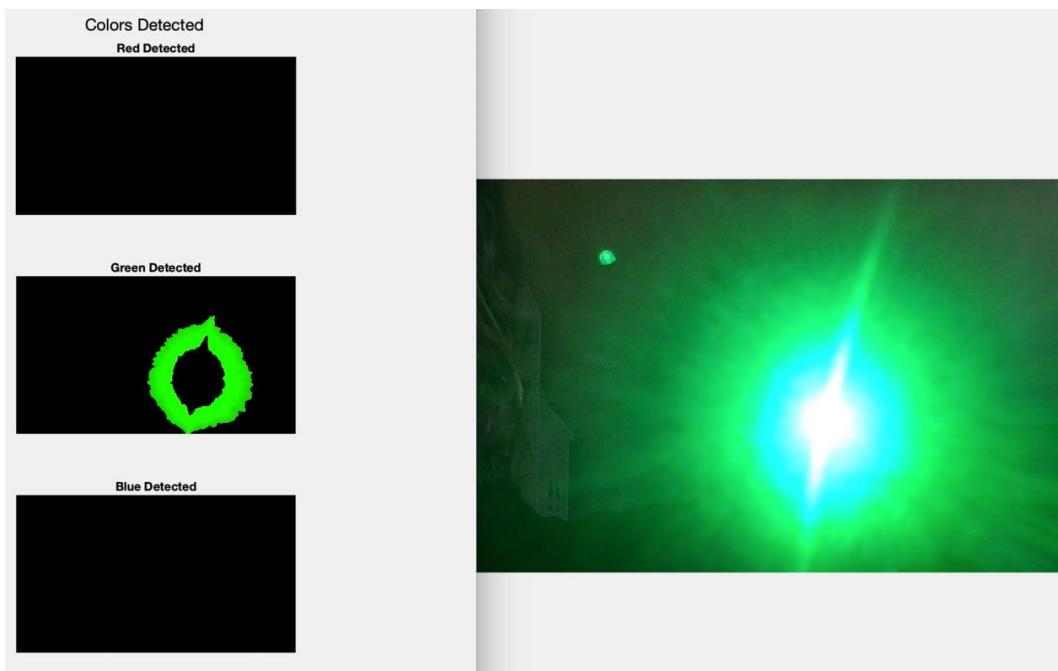

*Figure 68 Green LED with Lens Optical Demonstration*

As shown in the above pictures, the colors of the LED were grouped by color and separated by the MATLAB code. Also, the lens was able to significantly increase the color and area of the light. This has the potential to save us energy in our system, as we would not need multiple LEDs to still be bright enough for our system.



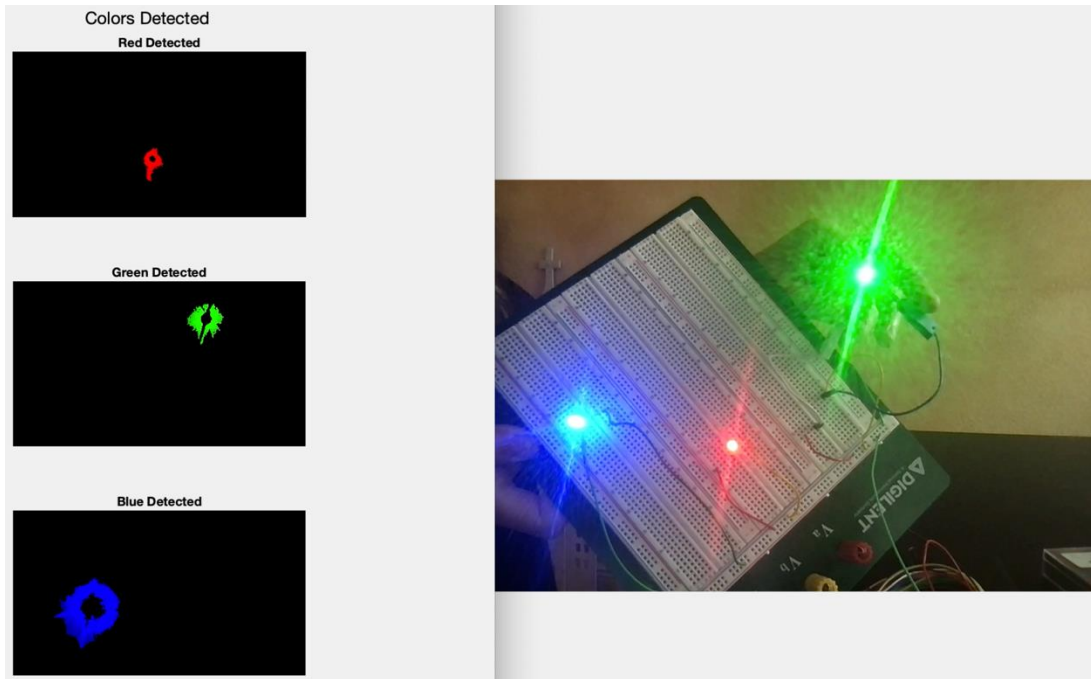

*Figure 69 Tri-Color LED Optical Demonstration*

Figure 69 shows what happens when multiple colors enter the system, it is still able to separate the colors accurately. This is like how the system will function if the household has multiple pets. The system will filter out the other colors not programmed for that feeder and will only activate for the correct one. This aspect of the demonstration is very promising for our overall design.

#### **6.1.2.2 IR LED and Photodiode Optical Demonstration**

In our optical demonstration, one IR LED and one photodiode were used to determine if the components we selected for this project would function the way we planned to use them. They were separated a bowls length away from each other (approximately 10 inches) as they would be in our final design. The setup is shown in Figure 70. The power of the photodiode in this setup was then measured and noted. This is the normal state of the feeder when a dog is not eating from it.

We were able to demonstrate how the IR LED and photodiodes will work in our overall design. The IR LED was set to 1.8 V using the Analog Discovery 2. The Analog Discovery 2 was then used as a power meter to observe the increase in power.

The connection between the photodiode and the IR LED was then interrupted as shown in Figure 71. The power was then again noted. This was repeated a few times to get an accurate power drop. This is what will happen as the dog is eating in the bowl and interrupting the LED signal.



*Figure 70 IR LED and Photodiode Setup*

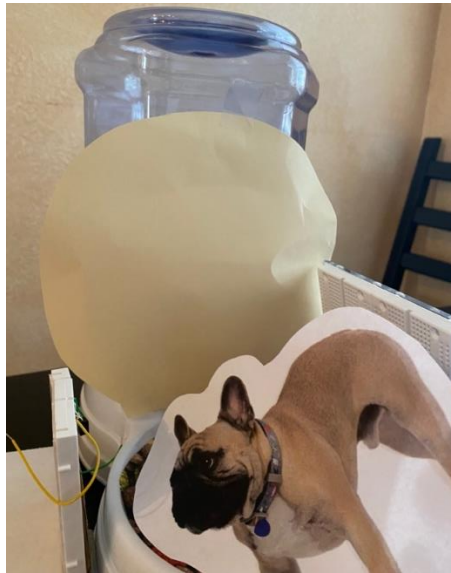

*Figure 71 IR LED and Photodiode Interruption*

After repeating the experiment multiple times, the below experimental data was collected. This data contains the voltage levels before and after the artificial dog was introduced in between the IR LED and the photodiode, as well as the difference in voltage levels during these two states.

*Table 31 IR LED and Photodiode Measurements*

	Uninterrupted Voltage	Interrupted Voltage	Voltage Difference
Trial 1	0.395 V	0.285 V	0.111 V
Trial 2	0.409 V	0.308 V	0.101 V
Trial 3	0.399 V	0.302 V	0.097 V
Trial 4	0.402 V	0.299 V	0.103 V
Average	0.401 V	0.298 V	0.103 V

After repeating the experiment four times, the measured voltage drop from the signal interruption was approximately 103 mV. This was a small-scale example of our project, for the actual device several LEDs and photodiodes will be used.

The LED and photodiode system were approximately aligned, (which will be improved in our final system) which will increase the power received. This was very promising for our experiment, as it shows that even at a bowls length distance away, we can still see a measurable voltage drop with only one LED and photodiode.

### **6.1.3 Lessons Learned from Optical Demonstration**

We learned many lessons in our optical demonstration. Some of those will be outlined below.

To minimize the light that is being captured by the photodiode, we could add a 950 nm filter to only get that wavelength. This will decrease the interrupted signal, which may be easier in the programming process of getting a low signal.

We could also modulate the signal of the IR LEDs to decrease the various random light being detected by the photodiode.

## **6.2 System Modules Testing**

In this section, we will discuss how the Opto-Smart pet feeder will be tested to ensure that it is functioning properly and adhering to our design specifications. Once our design is built up and all the parts are functioning, we will begin to test each of our specifications and ensure that they all pass as intended.

As discussed previously, our system will not be using a real dog, and will instead use our hands. If we wish to make it more realistic, we may choose to bring in a stuffed animal.

### **6.2.1 Camera System**

To find the detectable object distance, we will start a distance far away from the camera to find the distance where the system activates and starts to open. We will start approximately 25 feet away and slowly walk towards the system with the LED collar.

Once the system activates (detects the colored LED), the distance will be noted. This will be performed 10 times. The average will be taken to find the typical distance detected, as well as the minimum distance detected. We would like both numbers to be greater than 5 feet.

To make sure that the camera system can accurately detect at least three colors we must check three things: First, that when the correct color is presented to the system that it activates. Second, the system does not activate when the wrong color is presented. Third, that this works for all three colors.

To test this, we will have all three of the collars activated and working. We will stand 5 feet away from the system and present all three of the collars, one at a time. The system will be programmed for one color. For the system to be functioning properly, it should only respond when presented with the color collar programmed.

The system will then be reprogrammed to be activated for the second color. Each collar will again be presented one at a time to ensure the system activates only for the correct collar. This will be repeated for the third color, to ensure all are working properly.

### **6.2.2 IR LED Detection**

We want to ensure that our system has a quick response time to the LED detection to ensure that the lid closes in the proper amount of time.

To test this feature, the system will be activated by placing the correct collar in front of the system. Next, a hand or object will be placed just above the food bowl to imitate a dog head. It will be held there for 60 seconds to ensure the system is detecting that loss of power on the photodiodes and that the lid does not prematurely close. Next, the object will be taken away from the bowl, to ensure that the system is measuring a rise in power.

To ensure this matches our design specification, a stopwatch will be used to make sure that the lid is fully closed between 50 and 60 seconds after the object is taken away.

### **6.2.3 Motor and Dispensing**

It is critical that the proper amount of food is dispensed. If too much food is dispensed, then the pet will constantly be over fed which will lead to weight gain. If they do not receive enough food, they will suffer and be hungry, which is very dangerous for their health.

We want to ensure that the system dispenses  $\pm 10\%$  of the user inputted amount. To test this, we will have the system dispense a certain amount of food. A measuring cup will then be used to calculate precisely how much food is dispensed.

A timer will also be used to see how long it takes to finish dispensing the food, to ensure it takes less than 60 seconds. These tests will be done 10 times in the testing process to get an average as well as a maximum and minimum.

#### 6.2.4 Pet Collar System

It is vital that the electronics within the pet collar for the Opto-Smart Pet Feeder are always active and constantly providing power to the LED within the collar housing. If any of the electronics within the collar fail, the LED may not be turned on. This can result in the camera system being unable to detect any colored light coming from the pet's collar during a time when the pet is supposed to be eating.

To avoid any complications, a circuit that mirrors the function of the internals of the pet collar will be created and tested to ensure proper power delivery and lighting of the LEDs being used. Below is the physical circuit that was constructed to test the LEDs.

Since the circuits for the blue and green LEDs are functionally identical to that of the red LED, only the test results for the red LED are shown. This circuit will be powered by a sample 9V battery that will be connected to a voltage regulator module that will convert the 9V DC voltage to a usable 5V DC voltage. The 5V will then be sent across a resistor in series with the LED that was chosen for testing.

Since the voltage used for testing is 5V (6V will be the combined battery voltage of the batteries being used for the collar PCB) the resistor value was lowered from  $195\ \Omega$  to approximately  $110\ \Omega$ . It is expected that the LED will be on when the switch on the power module is pressed in and off when that same switch is unpressed.

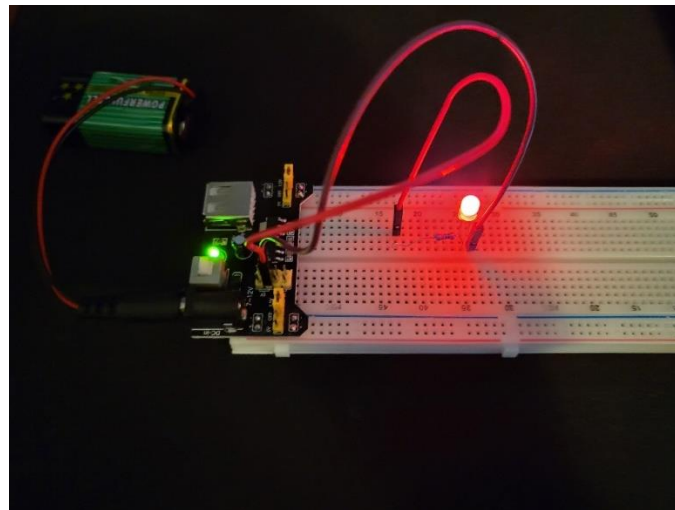

*Figure 72 Pet Collar Circuit Test*

According to the above circuit, it was found that the LED does turn on when the power switch is pressed. From this test, we will be able to extrapolate the results to fit the case of the pet collar PCB with a battery voltage of 6V and a larger limiting resistor value.

Using the battery calculations that were done earlier in this document, the LED should be able to remain on for much longer than the time needed for demonstration (approximately 14 hours). If the Opto-Smart Pet Feeder were able to be improved on in the future, it would help to make the pet collar contain rechargeable batteries and implement a charging system that did not involve removal of any of the pieces inside the collar.

## **7.0 Design Constraints and Standards**

This section discusses the standards relating to the Opto-Smart pet feeder, as well as the realistic design constraints of the project. These constraints may be financial, ethical, technological, or legal constraints. These must be noted and observed accordingly for this product to be a success.

This section contains:

- A list of design constraints relating to the Opto-Smart pet feeder.
- Standards that apply to the product.

### **7.1 Standards and other Safety Concerns**

In this section, various ethical and safety standards are addressed and examined. Also, there is a discussion pertaining to each standard and how it relates to our design. This section outlines the ethics of working with live animals (cats and dogs), and the safety protocols of working with soldering equipment.

#### **7.1.1 Standards for Working with and around animals**

The *Animal Welfare Act*, 7 U.S.C. § 2131 *et seq.* states the minimum requirements for the treatment and care of animals to be used in research applications.

This Opto-Smart pet feeder will not require the use of animals during the research and construction of the device. To test the finished design of the pet feeder with either dogs or cats, our group will have to abide by the standards proposed in the before mentioned *Animal Welfare Act*. Any animals that may be used during the process of testing the designed pet feeder will be treated humanely and given any human care and treatment needed to keep the dog/cat in a healthy state.

To test the Opto-Smart pet feeder without having to deal with any restrictions on working with real animals, artificial (stuffed) animals may be used to test the functionality of the LEDs on the collar. Most of the engineering requirement specifications will be able to be measured with the use of the artificial animals.

#### **7.1.2 LED Eye Safety Standards**

LEDs are small devices that emit tremendous amounts of light in a small space, this can be dangerous to the overall health of one's eyes from prolonged periods of time or even a short amount of time if it is a high-powered LED light source.

All LEDs are classified into different risk groups depending on how powerful the LED is. LEDs that emit blue or any bright light, are more dangerous than an LED that emits any other color or is dim. A very bright LED can cause permanent damage to the retina and can cause temporary blindness.

Table 32 LED Risk Groups

Risk Group	Risk	Definition
Exempt	None	No photobiological hazard
RG-1	Low Risk	No photobiological hazard under normal behavioral limitation
RG-2	Moderate risk	Does not pose a hazard due to aversion response to bright light or thermal discomfort
RG-3	High risk	Hazardous even for momentary exposure

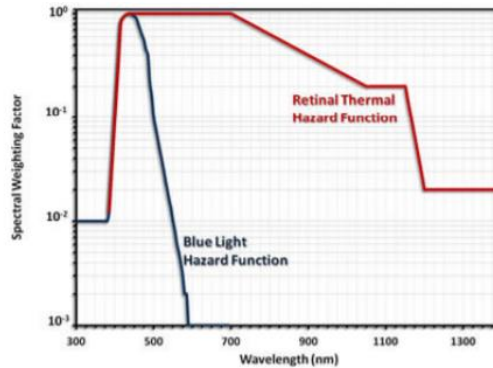

Figure 73 Retinal thermal and blue light hazard functions

Most LEDs fall into the low or the moderate category for risk, and so no protective equipment is required for handling or observing the LEDs. For this project it is important to choose LEDs that fall in the RG-1 or the Exempt category to avoid any chance for eye damage or irritation.

### 7.1.3 Soldering Standards

The National Aeronautics and Space Administration (NASA) published a national technical standard titled “Soldered Electrical Connections” that describes NASA’s process and requirements for soldered electrical connections.

In this document, they discuss proper soldering techniques along with many useful diagrams which this document will utilize here to show how exactly solder should be applied to the PCB. This documentation goes into elaborate detail about reliable solder connections, tool control, correct materials, proper processes, and careful workmanship. Another key feature that is used in this process to mitigate stress relief is the use of a plated-through hole during the mounting configuration.

Another step to ensure professional soldering is the use of the correct soldering equipment. This NASA document alludes to the mandatory use of: (Not in any specific order) Mechanical strippers, thermal strippers’ chemical strippers holding devices, bending tools, conductor cutting tools, anti-wicking tools, cleaning tools, and thermal shunts. The documentation reveals that proper solder and flux are paramount for correct solder



technique, they recommend flux covered solder of either composition SN60 or SN63 that contain flux type R or RMA for correct solder work.

Preparation of the surface that is about to be soldered is vital to a good soldering job. NASA created a table to show the safe and effective chemicals for removing oil and debris.

NOTE: These cleaners and solvents can potentially be hazardous and/or volatile. Before using any of the products listed below in Table 33, please consult with manufacturer guidelines and any safety data sheets present.

*Table 33 Solvents and Cleaners*

Solvent	Specification
Ethyl Alcohol	O-E-760, Types III, IV, or V
Isopropyl Alcohol	TT-I-735
Methyl Alcohol (see 3.12-2)	O-M-232, Grade A
Butyl Alcohol, Secondary (see 3.12-2)	ASTM-D1007
Cleaners	Specification/Note
Water	1 megohm-cm, minimum resistivity (see 6.13.3)
Detergent cleaners and saponifiers	(See 6.13.4)

Once the PCB has been cleaned properly, hand soldering may now commence. Molten solder must flow around the conductor and the termination areas, though one must be careful not to deposit too much solder or else the excess may flow to other terminals and cause a short. In this case de soldering must occur, and the work area must be cleaned before resoldering can take place. Another thing to watch out for is not applying enough solder, this can lead to poor contact and can affect the quality of the device.

#### **7.1.4 Lead Soldering Safety**

Soldering with lead can be extremely dangerous. Lead poisoning can have symptoms that can be noticed immediately, with long term affects that can last a lifetime. Harvard campus services Environmental health and safety states that the WHO (World Health Organization) has classified lead as a class 2A carcinogen, which means “it is probably carcinogenic to humans”.

Normal skin contact is harmless, the danger with lead soldering is that when melted with an electric soldering iron at high temperatures 300 – 500 degrees Celsius can cause the lead to vaporize into the air and can be inhaled. Symptoms can include headache, abdominal pain, joint and muscle pain, memory loss, mood disorders, cancer etc. safety precautions must be taken to ensure proper safety working with proper ventilation such as a fan or a fume hood can remove toxic fumes from the local atmosphere.

The next problem with solder is heat. A freshly soldered joint can be extremely hot! Avoid skin contact with freshly soldered joints and hot soldering irons, and wear gloves whenever possible.

After work is completed ensure, the workspace is free of lead dust (this is just as or more dangerous than the fumes) by washing surfaces with soapy water and clean towels. Also, do not use an air gun or a broom to clean lead solder dust, this can stir up the lead dust causing it to be inhaled.

### 7.1.5 Electrical Power Safety Standards (NFPA 1)

Section 11.1 of *NFPA 1* documents the basic electrical safety requirements when dealing with power adapters and extension cords. Any power strips used to deliver power to the Opto-Smart Pet Feeder must be rated for the correct current that must be fed into the electronics of the pet feeder. Power extension cords must not be plugged into separate external power strips (daisy chaining should be prohibited). To safely deliver power to the internal electronics (microcontroller and microprocessor) the power delivered to the circuit will be directly from a power outlet with the use of an adapter that delivers a constant voltage to both the microcontroller and microprocessor inside the housing of the pet feeder.

### 7.1.6 PCB Standards (IPC -2221A)

According to the Rigid Printed Board Committee (D-30) of IPC there are generic standards on printed board design (PCB). This covers the component mounting, design and interconnection requirements for PCB general designs including rigid, flex, PCMCIA, MCM-L, and HDIS.

PCB's must be of high quality for the product to have a long lifetime without any components needing repairs or replacements. IPC-2221A states the component the component parameters as follows:

*Table 34 PCB Design Tolerances*

Feature	Clearance
Component Leads	0.13 mm (up to a voltage of 50V)
Uncoated conducting areas (washers or similar mechanical hardware)	0.75 mm
Test Probe sites	80% of component height (0.6mm minimum and 5mm maximum)
Mounting Hardware	Should not protrude more than 6.4 mm below PCB surface
PTH (Plated through hole) relief in the heat sink	2.5 mm larger than the hole (includes electrical clearance and misregistration tolerance)

Data taken from <https://www.protoexpress.com/blog/ipc-2221-circuit-board-design/>



Figure 74 Example of clearance between traces on PCB

(Courtesy of <https://www.protoexpress.com/blog/ipc-2221-circuit-board-design/>)

Trace thickness must also be considered. Depending on the amount of current running through the trace will determine its thickness, wires can also be used as traces in some instances. The greater the amount of current flowing through the trace, the higher the temperature the trace will have due to its internal resistance. A larger trace will be able to withstand greater currents.

Insulation is also required in PCB design. This prevents short circuits and can prevent accidental contact with people, the environment, and the components themselves. This can be managed by using wires that already have insulation and by covering PCBs wherever possible with plastic or rubber. Grounding the components also helps with insulation

### 7.1.7 C Language Programming Standards

The current standard for the C programming language is *ISO/IEC 9899:2011*, which was originally established in 2011. This standard indicates the way C programs should be represented, the syntax of the C language, the rules for interpreting any C program, how input data is processed/output data is produced by a C program, and any restrictions put into place with the current implementation of C.

Any use of the C programming language to develop software for the Opto-Smart Pet Feeder must conform to the C standard above to be able to be portable across a variety of different devices that may utilize the created software.

## 7.2 Realistic Design Constraints

The Opto-Smart Pet Feeder has realistic design restraints as listed below in sections 7.2.1 through 7.2.10. These various restraints are being considered during the design process to create an optimal product that is price effective, ethical, and safe. Each constraint has been carefully considered regarding its realism had how it will be applied to the design.

### **7.2.1 Economic Constraints**

Historically, pet bowls are inexpensive. Many pet owners use normal bowls, which can be as inexpensive as a few dollars. With a target cost of around \$500, our elevated design will be one of the more expensive dog feeders on the market. With high-tech features comes a raised expensive. Our target audience will be owners who are on the go and need the luxury of a pet bowl that can feed their pets when they are not home.

### **7.2.2 Time Constraints**

The extent of the design of the Opto-Smart Pet Feeder will be determined by not only the economic constraints highlighted above, but also the time that is available to research, design, and test the product.

These developed time constraints will aid in the project outline by setting a template for when each section of our product creation/design should be completed. The research and part selection for the Opto-Smart Pet Feeder will be set to be complete by December 7, 2021, after which a realization of the proposed design should be able to be produced and tested.

At the end of the 2022 Spring semester (May 2022), the fully complete Opto-Smart Pet Feeder will be presented. By placing a time constraint of December 3, 2021, on the research, part selection, and PCB design, there will be enough time to properly analyze and correct any issues that may arise in the initial design process. If an originally proposed component of the Opto-Smart Pet Feeder will not be able to create within the given time frame, alternate design methods will need to be considered to meet the provided deadlines.

### **7.2.3 Environmental Constraints**

There are countless different automated pet feeders on the market today and they can be picked up just about anywhere. The Opto-Smart Pet feeder differs from many of these designs due to its designed being sourced from off the shelf components.

These components include all the mechanical, electrical, and optical elements of the design. Another positive aspect of this design is all these components can be bought cheaply and are high enough quality that this device can last the entire lifetime of the pet without failure. This reduces environmental waste and satisfies the environmental constraint

### **7.2.4 Ethical Constraints**

Care must be taken when designing any product that animals interact with. The amount of care should be amplified when designing a device with motors, gears, and electronics. Safety is the number one priority of this project, from the pets that will be using this project, the end users, and the design team members.

All gears and motors must be shielded so that they do not come into contact with the pet or the pet food. All electrical contact points must be covered insulated and properly grounded to prevent an electric shock to the user or the pet. The lid to the device must open to allow the pet to eat and must stay open while the pet is eating to avoid any injury to the pet.

All optical components of the device must also not interfere with the user or the pet's vision and must be shielded wherever necessary. The collar tag of the device must also always function to allow the pet to be able to eat.

It is also noted that the Opto-Smart Pet Feeder does not infringe on any existing patents, and any existing designs will not be used without the express permission of the patent holder with proper credit given.

### **7.2.5 Sustainability Constraints**

Most pet feeding bowls or devices that are available today are constructed to be able to last long periods of time without deterioration (normally on the scale of years). The Opto-Smart Pet Feeder will consist of multiple parts that are actively in motion, such as the covering lid as well as the motor that drives the dispensing system.

Due to the nature of the restricted amount of time provided for developing a working version of the Opto-Smart Pet Feeder, there will most likely not be adequate time available to test the longevity of the completed device. However, the quality of motor and choice of materials for the device will be selected to positively impact the lifespan of the designed pet feeder.

The longer the pet feeder can continue working without any electrical/mechanical failures, the less waste will be produced by any repairs done to the device and the user will not have any unexpected expenses regarding a replacement unit.

### **7.2.6 Social Constraints**

The target audience for our product are pet owners who lead busy lives and need assistance in ensuring their pets are properly fed.

With the recent COVID-19 outbreak, there has been a push to work from home. This has the potential to decrease the number of people in our target audience as many people who spent long hours in the office now may be working beside their pet.

As life begins to return to normal, these owners that are currently working from home may need to return to the office and will appreciate knowing their pets are well taken care of. All pet owners will need to leave their pets home alone at some point and could use the peace of mind knowing they are fed.

This product can be useful to all types of owners regardless of their employment status as it can prevent pets from eating out of their siblings' bowl and has a lid which helps keep the food fresh.

### **7.2.7 Political Constraints**

After examining the project carefully, it was determined that any potential political constraint was not relevant towards the Opto-Smart Pet Feeder

### **7.2.8 Health and Safety Constraints**

Working with animals comes with a responsibility to protect their health and safety. Since the Opto-Smart Pet Feeder will directly touch their food, care will be taken to ensure the food cannot be contaminated. Bisphenol A (BPA) free bowls and equipment will be used to prevent sickness. No sharp object will be placed in the bowls or the mechanism that will dispense the food to ensure safety.

Instructions for use of the product will be created for the user to ensure they are properly using the system. This will help eliminate user errors that can lead to injury. There will also be safety features implemented within our design to make sure no animals get hurt while eating out of our bowl.

The IR LEDs and photodiodes will be used to ensure that the lid does not close until the pet exits the area of the food bowl. This will make sure that the lid does not close on them. The effects of IR LEDs on the pets' eyes will be researched to ensure that no harm will come to the pets that stand in the lights path.

If our product does not function properly the pets may not be fed, which can lead to starvation. Thorough testing will be conducted to ensure that our product functions properly.

### **7.2.9 Manufacturability Constraints**

When creating the Opto-Smart Pet feeder, one must consider material availability, or the manufacturing constraint. At the time of writing this paper, COVID-19 is still causing supply chain issues around the world, this is causing severe impacts to nearly every business sector and has made ordering material much more difficult and expensive.

When selecting certain components, the team must work together to ensure that that piece of equipment can arrive at a reasonable time and at a reasonable price that still fits into the budget.

Prototyping this design will also be a challenge for this device, this will be made slightly easier using the Electrical and Photonic Engineering labs at the University of Central Florida. Unexpected costs such as equipment failure may also arise and may put strain on

an already tight budget, all these things must be considered while following to the manufacturability constraint.

#### **7.2.10 Testing/Presentation Constraints**

The main user of our product are pets. Preferably we would like to present using live animals to show real life use of the Opto-Smart Pet Feeder. The University of Central Florida has a No-Pet policy. This means we will not be able to bring in our own pets for the live demonstration.

Instead, stuffed animals may be used to show the functionality of the Opto-Smart Pet Feeder. Live pets will test out the product at home during the building phase and videos and photographs will be taken for proof of concept.

## 8.0 Administrative Concerns

This section is dedicated to displaying the administrative work the OptoSmart Pet Feeder team has put into the project. This section includes the project milestones that include the dates that the OptoSmart Pet Feeder team worked towards completing their goals and objectives. This section also includes the component cost list that itemizes the expenditure for each item for the project.

### 8.1 Schedule

This section includes a table outlining the project milestones for the OptoSmart Pet Feeder project ranging from August 2021 to May 2022 the entirety of the Senior design capstone project.

*Table 35 Project Milestones*

<b>Senior Design I</b>	<b>Who is completing the task</b>	<b>Start Date</b>	<b>Due Date</b>	<b>Status</b>
<b>Understanding the scope of the project</b>	Group 9	8/26/2021	9/3/2021	Completed
<b>Role assignments</b>	Group 9	9/3/2021	9/3/2021	Completed
<b>Identify parts</b>	Group 9	9/10/2021	12/3/2021	In Progress
<b>Project report</b>				
Initial Document	Group 9	9/10/2021	9/17/2021	Completed
Updated initial document	Group 9	9/17/2021	10/1/2021	Completed
First draft	Group 9	8/1/2021	11/5/2021	Completed
Final draft	Group 9	11/5/2021	11/19/2021	In Progress
Final document	Group 9	11/19/2021	12/7/2021	In Progress
<b>Research, documentation, and design</b>				
Microcontroller	Ricky	9/17/2021	12/3/2021	Completed
Lens design	Tyler	9/17/2021	12/3/2021	Completed
Circuitry	Jacob	9/17/2021	12/3/2021	Completed
PCB	Jacob	9/17/2021	12/3/2021	Completed



Table 36 Project Milestones Cont.

Schematics	Jacob/Ricky	9/17/2021	12/3/2021	Completed
LEDs	Cassidy	9/17/2021	12/3/2021	Completed
Cameras	Tyler	9/17/2021	12/3/2021	Completed
Motors	Tyler	9/17/2021	12/3/2021	Completed
Dispensers	Jacob	9/17/2021	12/3/2021	Completed
Housing for electronics	Jacob	9/17/2021	12/3/2021	Completed
Photodiode	Cassidy	9/17/2021	12/3/2021	Completed
Gear Mechanisms	Jacob/Tyler	9/17/2021	12/3/2021	Completed
Code used for project	Ricky	9/17/2021	12/3/2021	Completed
Order and test parts	Group 9	9/17/2021	11/22/2021	Parts have been ordered and tested
<b>Senior Design II</b>				
<b>Build prototype</b>		TBD	TBD	
<b>Testing and redesign</b>		TBD	TBD	
<b>Finalize prototype</b>		TBD	TBD	
<b>Practice presentation</b>		TBD	TBD	
<b>Final Report</b>		TBD	TBD	
<b>Final Presentation</b>		TBD	TBD	

## 8.2 Financial Considerations

With a current budget of about \$500, we have used our full budget with a total of 501.28. The prices listed below in Table 37 are estimated using online research. They may be adjusted slightly as the project gets closer to being produced. The final cost of the product will be evenly split between all the group members.

Table 37 Component List (Bill of Materials)

Item	Cost	Quantity	Total
Camera	\$10.64	1	\$10.64
FRP125 Lens	\$23.27	3	\$69.81
RL5-R8030 (Red LED)	\$0.28	25	\$7.00
Green LED (25 pk)	\$8.00	1	\$8.00
Blue LED	\$8.00	1	\$8.00
Photodiode	1.03	25	25.75
IR LED	\$0.87	25	\$21.75
Raspberry Pi Kit	\$127.79	1	\$127.79
Soldering station	\$41.59	1	\$41.59
Pet collar battery (CR1632)	\$5.99	1	\$5.99
PLA 3D Printer Filament (Black)	\$20.49	1	\$20.49
Stainless steel large dish	\$13.57	1	\$13.57
Adjustable dispensing wheel	\$19.99	1	\$19.99
11/32 in. or 3/8 in. x 4 ft. x 8 ft. BC Sanded Pine Plywood	\$28.00	1	\$28.00
PCB Board (Set 5)	\$34.99	1	\$34.99
9 V Power Adapter	\$19.99	1	\$19.99
Arduino	\$19.95	1	\$19.95
Switch and Battery Case	\$4.99	1	\$4.99
Lead Free Solder	\$12.99	1	\$12.99
<b>Total</b>			<b>\$501.28</b>

## **9.0 Conclusion**

By combining optics and photonics with electrical and computer science, the Opto-Smart pet Feeder was born. The Opto-Smart Pet Feeder will be able to bring peace of mind to busy pet owners.

By allowing owners to select feeding times, and the appropriate amount of food, pets will always be properly fed. This user-friendly app brings customized feeding features to the pet owner. By having a lid that will open when the corresponding pet enters the vicinity, pets will not be able to steal the food of their siblings. This is very useful for overweight pets that eat too many servings of food, and the other pet that's food is being eaten. The Opto-Smart Pet Feeder can also be used for pets that have to take medication as the lid will ensure only the correct pet is eating out the bowl. The lid will not close while the integrated photodiodes do not detect the IR LEDs because of the pet standing in the way.

Once the photodiodes detect the IR LEDs a countdown will start and if the pet does not interrupt the signal the lid will close. This ensures no other pets can eat out of their bowl. The overall design of the Opto-Smart Pet Feeder strives to bring a self-sufficient method of properly feeding multiple pets without any need for human assistance using the integrated optics and electronics. In addition, the software developed will enable the user to configure this pet feeding system to be customized for each individual pet.

## 10.0 Appendix

### 10.1 Appendix A: Code

#### 10.1.1 Optical Demonstration MATLAB Code

The below code was used in the optical demonstration to show a working concept of our colored LED collar.

```
clear all;
clc;

while(1);
    imaqreset
    info= imaqhwinfo;
    Cam= videoinput('macvideo'); %macvideo works with mac, would need to change if used on a
    windows computer
    set(Cam, 'FramesPerTrigger', Inf);
    set(Cam, 'ReturnedColorSpace', 'rgb')
    Cam.FrameGrabInterval = 5 ;
    start(Cam);
    preview(Cam);

    while(Cam.FramesAcquired <= 600)
        Mac_Vid = getsnapshot(Cam);

    sgtitle('Colors Detected')

    % Red
    Red=Mac_Vid(:,:,1); Green=Mac_Vid(:,:,2); Blue=Mac_Vid(:,:,3);
    red_to_gray=imsubtract(Red,rgb2gray(Mac_Vid));
    red_filter=medfilt2(red_to_gray,[3 3]);
    red_gray_to_bw=imbinarize(red_filter,0.3);
    Red_Det=bwareaopen(red_gray_to_bw,500);
    R=sum(Red_Det(:));
    rr=immultiply(Red_Det,Red); gr=Green.*0; br=Blue.*0;
    red_detected=cat(3,rr,gr,br);
    subplot(3,1,1);
    imshow(red_detected);
    title('Red Detected');

    % Green
    Red=Mac_Vid(:,:,1); Green=Mac_Vid(:,:,2); Blue=Mac_Vid(:,:,3);
    green_to_gray=imsubtract(Green,rgb2gray(Mac_Vid));
    green_filter=medfilt2(green_to_gray,[3 3]);
    green_gray_to_Bw=imbinarize(green_filter,0.3);
    Green_Det=bwareaopen(green_gray_to_Bw,500);
```

```

G=sum(Green_Det(:));
gg=immultiply(Green_Det,Green); rg=Red.*0; bg=Blue.*0;
green_detected=cat(3,rg,gg,bg);
subplot(3,1,2);
imshow(green_detected);
title('Green Detected');

% Blue
Red=Mac_Vid(:,:,1); Green=Mac_Vid(:,:,2); Blue=Mac_Vid(:,:,3);
blue_to_gray=imsubtract(Blue,rgb2gray(Mac_Vid));
blue_filter=medfilt2(blue_to_gray,[3 3]);
blue_gray_to_BW=imbinarize(blue_filter,0.4);
blue_det=bwareaopen(blue_gray_to_BW,500);
B=sum(blue_det(:));
bb=immultiply(blue_det,Blue);
rb=Red.*0;
gb=Green.*0;
blue_detected=cat(3,rb,gb,bb);
subplot(3,1,3);
imshow(blue_detected);
title('Blue Detected');

end
choice = menu('Continue?','Yes','No');
if choice==2 | choice==0
    break;
end
end

stop(Cam);
delete(Cam);
clear;

```

## 10.2 Appendix B: Works Cited

(7 USC, 2131-2156: Animal Welfare Act as amended. ; Ada; Advantages of fresnel lenses: Edmund Optics. ; Applying IPC-2221 standards in circuit board design; DigiKey; DigiKey; Electronics; Institute.; Instruments; Laboratory safety guideline - ehs.harvard.edu. ; Lead soldering safety. ; LEDs.; NASA; Newark; Solutions; Tech.; What is a market requirements document (MRD)? )

7 USC, 2131-2156: Animal Welfare Act as amended. . Retrieved 11/5/2021 from <https://ori.hhs.gov/content/Chapter-4-The-Welfare-of-Laboratory-Animals-7-usc-2131-2156-animal-welfare-act-amended>.

Ada, L. Ladyada's learn Arduino - lesson #0. . Retrieved 11/5/2021 from <https://learn.adafruit.com/ladyadas-learn-arduino-lesson-number-0/power-jack-and-supply>.

*Advantages of fresnel lenses: Edmund Optics.* . Edmund Optics Worldwide. . Retrieved 11/4/2021 from <https://www.edmundoptics.com/knowledge-center/application-notes/optics/advantages-of-fresnel-lenses/>.

*Applying IPC-2221 standards in circuit board design.* Sierra Circuits. . <https://www.protoexpress.com/blog/ipc-2221-circuit-board-design/>.

DigiKey. *MV50154.* <https://www.digikey.com/en/products/detail/everlight-electronics-co-ltd/MV50154/2675588>.

DigiKey. *NTE30048 NTE Electronics, Inc* [https://www.digikey.com/en/products/detail/nte-electronics-inc/NTE30048/11656062?utm\\_adgroup=General&utm\\_source=google&utm\\_medium=cpc&utm\\_campaign=Shopping\\_DK%2BSupplier\\_NTE+Electronics&utm\\_term=&utm\\_content=General&gclid=Cj0KCQjwiNSLBhCPARIsAKNS4\\_fu6Bn04j4uTPxfgXqo9Eu2no6DbLC-qBbbrbXBZ0HX9USdLgt8Sr0aAqzuEALw\\_wcB](https://www.digikey.com/en/products/detail/nte-electronics-inc/NTE30048/11656062?utm_adgroup=General&utm_source=google&utm_medium=cpc&utm_campaign=Shopping_DK%2BSupplier_NTE+Electronics&utm_term=&utm_content=General&gclid=Cj0KCQjwiNSLBhCPARIsAKNS4_fu6Bn04j4uTPxfgXqo9Eu2no6DbLC-qBbbrbXBZ0HX9USdLgt8Sr0aAqzuEALw_wcB).

Electronics, M. M. *BPV23FL vishay semiconductors:* [https://www.mouser.com/ProductDetail/Vishay-Semiconductors/BPW82?qs=%2Fjqivxn91ccMymVfeKLCiQ%3D%3D&mgh=1&gclid=CjwKCAjwoP6LBhBlEiwAvCcthP8FVGG7vE6qljzfpbmBpahgjL9pS4eiA-TOf1cBbYE-fLa6JnMoRoCBrUQAvD\\_BwE](https://www.mouser.com/ProductDetail/Vishay-Semiconductors/BPW82?qs=%2Fjqivxn91ccMymVfeKLCiQ%3D%3D&mgh=1&gclid=CjwKCAjwoP6LBhBlEiwAvCcthP8FVGG7vE6qljzfpbmBpahgjL9pS4eiA-TOf1cBbYE-fLa6JnMoRoCBrUQAvD_BwE).

Institute., L. I. 7 *U.S. Code § 2131 - Congressional Statement of Policy.* <https://www.law.cornell.edu/uscode/text/7/2131>.

Insturments, T. *MSP430FR6989 data sheet, product information and support* <https://www.ti.com/product/MSP430FR6989#features>.

Laboratory *safety guideline - ehs.harvard.edu.* [https://www.ehs.harvard.edu/sites/default/files/lab\\_safety\\_guideline\\_mercury.pdf](https://www.ehs.harvard.edu/sites/default/files/lab_safety_guideline_mercury.pdf).

*Lead soldering safety.* . <https://blink.ucsd.edu/safety/occupational/hazard-control/lead-soldering.html>.

LEDs., S. B. *RL5-R8030.* . [https://www.superbrightleds.com/moreinfo/through-hole/5mm-red-led-30-degree-viewing-angle-8000-mcd/281/1208/?utm\\_campaign=Child%2B-%2BOrganic%2BShopping&utm\\_source=More%2BLED%2BLighting%2B%3E%2BThrough%2BHole&utm\\_medium=RL5-R8030](https://www.superbrightleds.com/moreinfo/through-hole/5mm-red-led-30-degree-viewing-angle-8000-mcd/281/1208/?utm_campaign=Child%2B-%2BOrganic%2BShopping&utm_source=More%2BLED%2BLighting%2B%3E%2BThrough%2BHole&utm_medium=RL5-R8030).

NASA. *Soldered electrical connections -* <https://nepp.nasa.gov/docuploads/06AA01BA-FC7E-4094-AE829CE371A7B05D/NASA-STD-8739.3.pdf>.

Newark. *S2386-5K - photo diode, 960NM, 5PA, to-5-2.* . [https://www.newark.com/hamamatsu/s2386-5k/photo-diode-960nm-5pa-to-5-2/dp/21AH4487?gclid=CjwKCAjwoP6LBhBlEiwAvCcthPKbQgHwom7tX8J7ExXF\\_v1ZHVgiAlOW5JJEfBweDPOTOHemLZdORhoCbVMQAvD\\_BwE&mckv=sodAuYEFh\\_dc%7Cpcrid%7C509808252197%7Cplid%7C%7Ckword%7C%7Cmatch%7C%7Cslid%7C%7Cproduct%7C21AH4487%7Cpgrid%7C100464450946%7Cptaid%7Cpla-904062949885%7C&CMP=KNC-GUSA-GEN-Shopping-NewStructure-Optoelectronics-Displays](https://www.newark.com/hamamatsu/s2386-5k/photo-diode-960nm-5pa-to-5-2/dp/21AH4487?gclid=CjwKCAjwoP6LBhBlEiwAvCcthPKbQgHwom7tX8J7ExXF_v1ZHVgiAlOW5JJEfBweDPOTOHemLZdORhoCbVMQAvD_BwE&mckv=sodAuYEFh_dc%7Cpcrid%7C509808252197%7Cplid%7C%7Ckword%7C%7Cmatch%7C%7Cslid%7C%7Cproduct%7C21AH4487%7Cpgrid%7C100464450946%7Cptaid%7Cpla-904062949885%7C&CMP=KNC-GUSA-GEN-Shopping-NewStructure-Optoelectronics-Displays).

Solutions, C. P. *Applying IPC standards to PCB layout design.* . <https://resources.pcb.cadence.com/blog/2021-applying-ipc-standards-to-pcb-layout->

[design#:~:text=For%20PCB%20designers%2C%20the%20must,be%20implemen ted%20on%20a%20PCB.](#)

Tech., R. (11/4/2021). *Real-time color detection using webcam and Arduino.* <https://www.robotique.tech/robotics/real-time-color-detection-using-webcam-and-arduino/>.

What is a market requirements document (MRD)? . Retrieved 2021, September 28 from <https://www.aha.io/roadmapping/guide/requirements-management/what-is-a-market-requirements-document>.

### 10.3 Appendix C: Datasheet Material

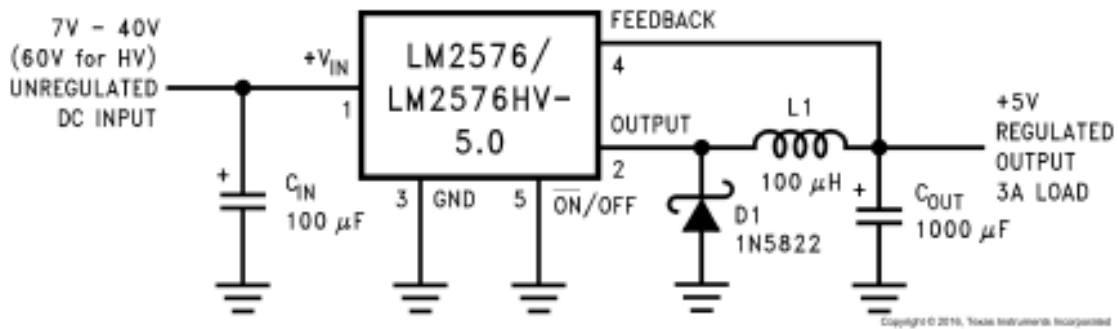

Figure 75 Voltage Regulator Circuit from LM 2576 Datasheet (Courtesy of Texas Instruments)

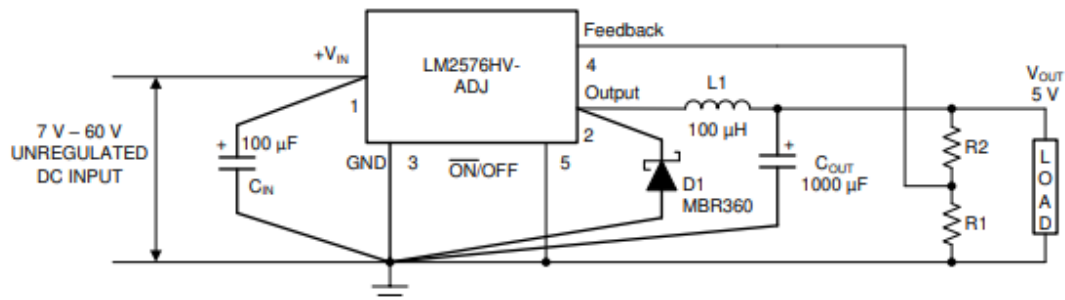

Figure 76 Adjustable Voltage Regulator Circuit from LM 2576 Datasheet (Courtesy of Texas Instruments)

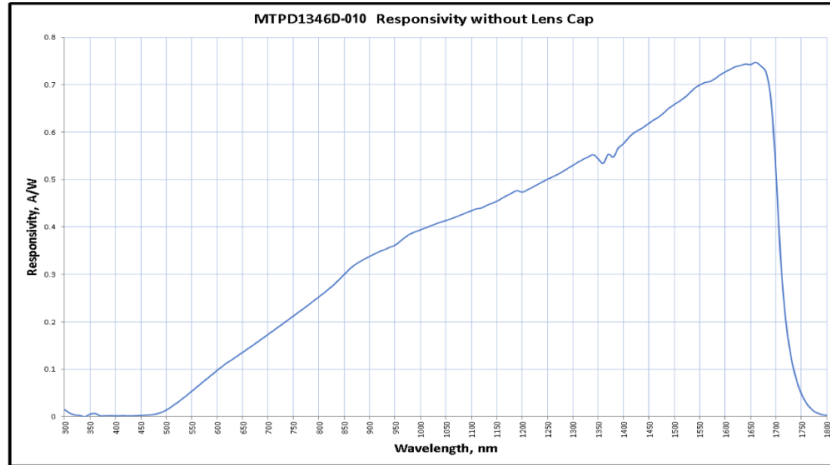

Figure 77 MTPD1346D-010 Responsivity Spectrum

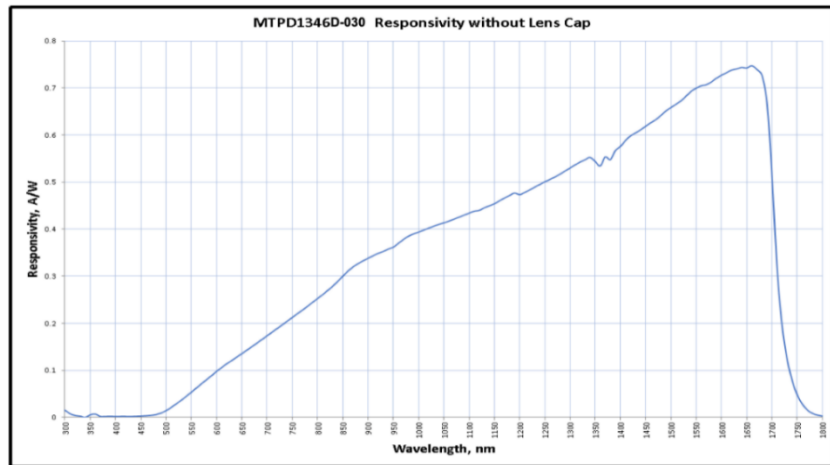

Figure 78 MTPD1346D-030 Responsivity Spectrum

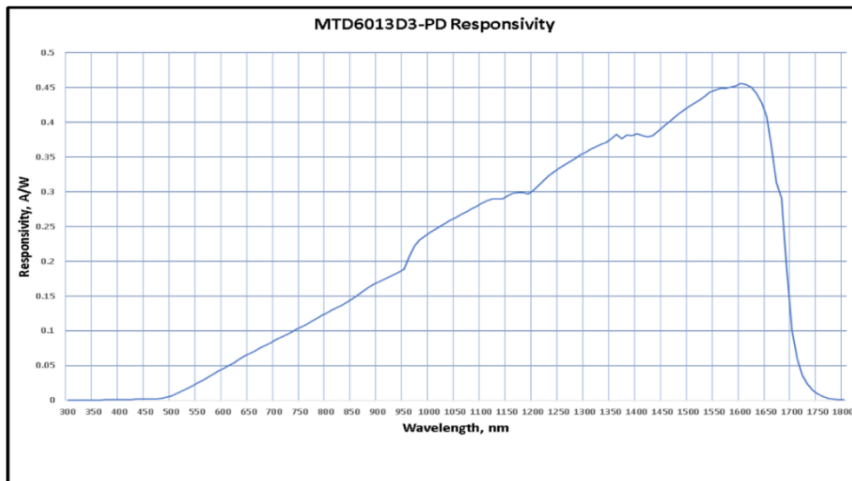

Figure 79 MTD6013D3-PD Responsivity



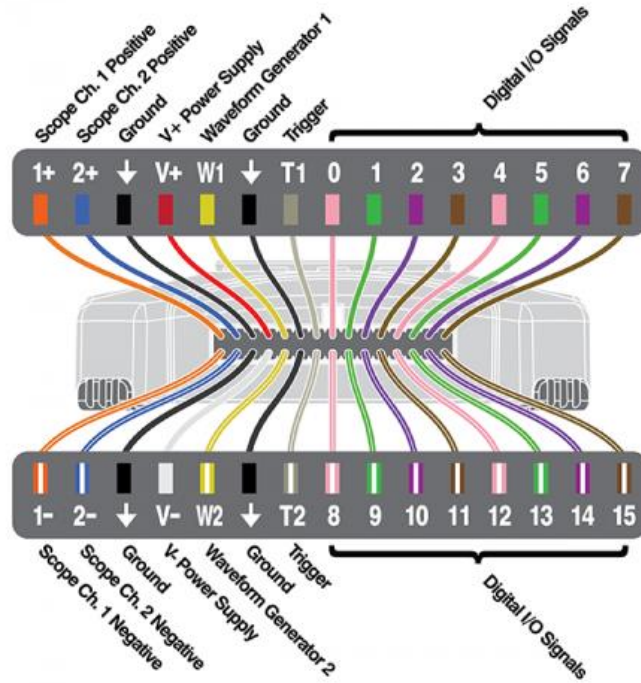

Figure 80 Analog Discovery Two Schematic