

Opto-Smart Pet Feeder

Senior Design I

Initial Project Document and Group Identification

University of Central Florida

Department of Electrical Engineering and Computer Science

College of Optics and Photonics

Group 9

Tyler Knight	CREOL
Cassidy Coll	CREOL
Ricky Egawa	Computer Engineering
Jacob Haas	Electrical Engineering

Table of Contents

1.0	Executive Summary	1
2.0	Project Description.....	2
2.1	Project Background.....	2
2.2	Objectives	3
2.2.1	Goals	3
2.2.2	Motivation.....	3
2.2.3	Design A	4
2.2.4	Design B.....	4
2.3	Requirement Specifications	4
2.4	Features	5
2.4.1	Core Features	6
2.4.2	Advanced Features.....	6
2.4.3	Stretch Features.....	6
2.5	Marketing and Engineering Requirements	6
2.6	Functionality of the Opto-Smart Pet Feeder	8
2.6.1	Website / App Functionality	10
3.0	Financial Considerations.....	11
4.0	Research related to Project Definition	12
4.1	Existing Projects and Products.....	12
4.1.1	Automated Feeder Design.....	12
4.2	Accessories	14
4.2.1	Camera System	14
4.3	Relevant Technologies.....	15
4.3.1	Fresnel Lens	15
4.3.2	Photodiodes.....	15
4.3.3	LED's.....	16
4.3.4	Voltage Regulators.....	16
4.3.5	Microcontroller	16
5.0	Research and Part Selection.....	17
5.1	Bowl and Lid System.....	17
5.1.1	Food Holder	18

5.1.1.1	Pet Zone Designer Diner Adjustable Elevated Dog Bowls	19
5.1.1.2	IRIS Elevated Dog Bowls - Elevated Dog Feeder.....	19
5.1.1.3	Adjustable Wood Dog Bowl Stand.....	20
5.1.1.4	Gofetch Stainless Steel Pet Food Bowl with Double Diner	21
5.1.2	Lid.....	22
5.1.2.1	Lid Motor	22
5.1.2.1.1	Bridgold L293D Chip	22
5.1.2.1.2	HiLetgo ULN2003 4-Phase Stepper Motor with 5V Drive Board	23
5.1.2.2	Three-Dimensional Printing.....	24
5.1.2.2.1	Texas Instruments Innovation Lab at UCF	24
5.1.2.2.2	Lockheed Martin IDEA Lab	24
5.2	LED.....	24
5.2.1	LED Equations.....	24
5.2.2	IR LED Options	24
5.2.2.1	NTE30048.....	25
5.2.2.2	SFH 4546-AWBW	25
5.2.2.3	MTE9460N5	25
5.2.3	LED Comparison	26
5.3	Photodiode	26
5.3.1	Photodiode Equations	27
5.3.2	Photodiode Options.....	27
5.3.2.1	S2386-5K	28
5.3.2.2	BPV23FL	28
5.3.2.3	BPW82.....	28
5.3.3	Photodiode Comparison.....	28
5.4	Printed Circuit Board (PCB).....	29
5.4.1	Designing a PCB.....	29
5.4.1.1	Determine what the PCB needs to do	29
5.4.1.2	Pet Collar PCB Battery Selection	30
5.4.1.3	Pet Collar PCB Development Software.....	30
5.4.1.4	PCB Development Costs	31
5.5	Pet Collar System.....	31
5.5.1	Pet Collar	31

5.5.2	Lens System	31
5.5.2.1	Planoconvex Lens	31
5.5.2.2	Zemax (Optics Studio) Calculations	32
5.5.2.3	LA1951 – N-BK7 Plano-Convex Lens	33
5.5.2.4	Fresnel Lens	33
5.5.2.4.1	Fresnel Lens Equations	34
5.5.2.4.2	Shappy Thin Fresnel Lens Pocket Size Magnifier Lenses.....	35
5.5.3	Color LEDs	35
5.5.3.1	Single Color LED	35
5.5.3.2	Single Color LED Options.....	36
5.5.3.2.1	C5SMF-RJF-CT0W0BB2	36
5.5.3.2.2	RL5-R8030	37
5.5.3.2.3	MV50154	37
5.5.3.2.4	Single Color LED Comparison.....	37
5.5.3.3	Multi Color LED.....	37
5.6	Camera System	38
5.6.1	Raspberry Pi Camera v2	39
5.6.2	BBTO OV5647 Mini Camera Module	39
5.6.3	Ximimark USB Camera (LY096).....	40
5.6.5	Camera Comparison.....	40
5.7	Food Dispenser	41
5.8	Microcontroller	41
5.8.1	Arduino Uno Rev 3.....	42
5.8.2	MSP 430FR6989.....	42
5.9	Microprocessor	43
5.9.1	Raspberry Pi 4.....	43
5.10	Software Tools	44
5.10.1	Python	44
5.10.2	C.....	44
5.10.3	C++	45
5.10.4	Atom	45
5.10.5	HTML	45
5.10.6	CSS	45
5.10.7	Java	46

5.10.8	JavaScript.....	46
5.10.8.1	React Native.....	46
5.10.8.2	Reactjs.....	46
5.10.9	Visual Studio Code	47
5.10.10	GitHub.....	47
5.10.11	Firebase.....	47
5.10.12	Ubuntu.....	47
5.10.13	MATLAB.....	48
5.10.14	SOLIDWORKS	48
5.10.15	Repl.it.....	48
5.10.16	Heroku.....	48
5.10.17	Flutter.....	48
5.10.18	SwaggerHub.....	49
5.10.19	C#.....	49
6.0	Design	49
6.1	Bowl and Lid System Design	50
6.2	LED Design	50
6.3	Photodiode Design.....	50
6.4	PCB Design.....	50
6.5	Pet Collar System Design	50
6.6	Camera System Design.....	50
6.7	Food Dispenser Design.....	50
6.8	Microcontroller Design.....	51
6.9	Microprocessor Design.....	51
6.10	Software Design.....	53
7.0	Testing Design	53
8.0	Design Constraints and Standards	54
8.1	Standards and other Safety Concerns	54
8.1.1	Standards for Working with and around animals	54
8.1.2	Soldering Standards	54
8.1.3	Lead Soldering Safety.....	55
8.1.4	Electrical Power Safety Standards (NFPA 1).....	56
8.1.5	PCB Standards (IPC -2221A).....	56
8.1.6	C Language Programming Standards	57

8.2	Realistic Design Constraints	57
8.2.1	Economic Constraints	58
8.2.2	Time Constraints	58
8.2.3	Environmental Constraints.....	58
8.2.4	Ethical Constraints	58
8.2.5	Sustainability Constraints	59
8.2.6	Social Constraints	59
8.2.7	Political Constraints	59
8.2.8	Health and Safety Constraints.....	59
9.0	Conclusion	60
10.0	Appendix.....	61
10.1	Schedule.....	61
10.2	Acronyms.....	62
10.3	Work Cited.....	63

Table of Figures

Figure 1	Opto-Smart Role Assignment Block Diagram	5
Figure 2	Opto-Smart Self Closing Lid Block Diagram	8
Figure 3	Opto-Smart Camera and Collar System	8
Figure 4	Opto-Smart Lid in Open Position, Activated by Pet	9
Figure 5	Opto-Smart Lid in Preparing to Close, No longer Activated by Pet.....	9
Figure 6	Existing Automated Food Dispenser Design	12
Figure 7	Existing Automated 5 Meal Feeder Design.....	13
Figure 8	Existing Automatic Feeder Design with Self-Opening/Closing Lid.....	13
Figure 9	Existing LED collar design (Courtesy of puppykisses.com).....	14
Figure 10	Example of color object tracking (Courtesy of roborealm.com).....	14
Figure 11	Pet Zone Designer Diner Adjustable Elevated Dog Bowl	19
Figure 12	IRIS Elevated Dog Bowls - Elevated Dog Feeder	20
Figure 13	Adjustable Wood Dog Bowl	21
Figure 14	Gofetch Stainless Steel Pet Food Bowl with Double Diner	22
Figure 15	Motor Controlling Scheme	22
Figure 16	Bridgold L293D.....	23
Figure 17	HiLetgo Stepper Motor with Drive Board.....	23
Figure 18	Example of a Photodiode.....	26
Figure 19:	Layput of Plano-Convex Lens.....	32
Figure 20	Spot diagram of plano-convex lens	33
Figure 21:	LA1951 Lens from ThorLabs.....	33
Figure 22	Fresnel Lens.....	34
Figure 23	Shappy Fresnel Lens.....	35
Figure 24	Example of a single-color LED.....	36
Figure 25	Example of a Multi Color LED	38

Figure 26 Pinout diagram for a Multi Color LED	38
Figure 27 Raspberry Pi Camera v2.....	39
Figure 28 OV5647 Mini Camera Module.....	39
Figure 29 Ximimark USB Camera	40
Figure 30 Arducam Mini Module OV2640	40
Figure 31 Arduino Uno Rev 3	42
Figure 32 MSP 430FR6989	43
Figure 33 Raspberry Pi 4	44
Figure 34 Opto-Smart Pet Bowl Layout	50
Figure 35 Physical Concept of Dispensing Wheel	51
Figure 36 CanaKit Raspberry Pi 4 4GB Starter PRO Kit.....	52
Figure 37 Example of clearance between traces on PCB	57

List of Tables

Table 1 Requirement Specifications	5
Table 2 House of Quality diagram.....	7
Table 3 Component List.....	11
Table 4 Dog Feeding Chart.....	18
Table 5 Bridgold L293D Ratings.....	23
Table 6 LED Comparison Chart	26
Table 7 Photodiode Comparison Chart.....	28
Table 8 Pet Collar PCB Battery Comparison	30
Table 9: Single LED comparison.....	37
Table 10 Camera Comparison	41
Table 11 Solvents and Cleaners.....	55
Table 12 PCB Design Tolerances	56
Table 13 Project Milestones.....	61
Table 14 Acronym List.....	62

Table of Equations

Equation 1 LED Voltage Equation	24
Equation 2 Photocurrent	27
Equation 3 Total Photodiode Current	27
Equation 4 Responsivity of a Photodiode.....	27
Equation 5 Lens Makers Equation.....	34
Equation 6 Fresnel Lens Focal Length	34
Equation 7 Fresnel Magnification.....	34
Equation 8 Fresnel Loss.....	34
Equation 9 Snell's Law	35

1.0 Executive Summary

There are many different types of pet feeders on the market today, but few employ the use of electronics to automatically dispense pet food and most of those products rely on simple timers and can only serve one pet at a time. With many people going back to the office after the COVID-19 pandemic, pets around the world are suffering due to a sudden change to their everyday dietary routine. This product helps eliminate the time, energy, and stress put on the pet owners to feed their pets while they're away from home. Using optics and electrons, the device ensures that the owner's pets are being routinely fed with their correct pet food, without the pet owner being physically present with them. Devices that autonomously feed pets do already exist, however, the use of optics to better ensure that the pets are routinely fed with the proper pet food is what differentiates our product from others that are already on the market today.

The opto-smart pet feeder contains two main and separate parts to properly feed the user's pets. The first main component is the tag on the collar the user's pets must always wear.

The tag on the collar that is initially described functions as a pet specific identification tag for the feeder to read and acknowledge to dispense the pet food for that specific pet. To do this, an LED light that is embedded inside of the tag's water-resistant plastic container emits a specific color of light that the pet feeder can recognize and dispense the correct pet food for that specific pet. This function is especially useful for houses with more than one pet, as the user's second and third pets can wear a collar tag that emits a different color of light than a color that is already in use to properly distinguish and recognize to dispense the pet food for that specific pet accordingly.

The second main component is the autonomous feeder that dispenses the pet's food. The pet feeder contains a compact camera inside the feeding system that monitors and searches the area for the predetermined color of light that is illuminating from the tag on the pet's collar. The user can further decide the specific time of day in which the pet feeder can scan and detect the light coming from the tag on the pet's collar. At that specific time of day predetermined and set by the user, if the selected color of the LED light is illuminating from the tag on the pet's collar and captured on camera for the system to detect, the pet feeder will dispense the appropriately set amount of pet food into the corresponding pet's bowl. Once the food has been dispensed to the pet's bowl, the correct lid will open, allowing the pet to eat its food from the bowl. Infrared LEDs surrounding the bowl will constantly be providing the photodiodes as a signal. Once the pet begins eating from the bowl, the photodiodes will be blocked, causing the lid to remain open until the pet completely removes its head from the bowl. Once the detectors regain the signal from the infrared LEDs, a countdown to close the bowl begins. If something does not block the signal within the time the user selects, the lid will properly close automatically.

For the device to properly function and to fully accomplish all tasks mentioned above, several lines of functions and methods in code must be written and implemented into the microcontroller embedded inside the system. The code executed and compiled into the microcontroller must be written well enough for the pet feeder to be able to correctly

identify and distinguish if the selected color of LED light shining from the tag attached to the pet's collar exists in the camera's point of view. Once the correct color of LED light is recognized and acknowledged by the system code in the microcontroller, the dispenser will release the proper pet food for the corresponding pet to eat. The written code must also dispense the accurate amount of food the users decide to feed for that specific pet. The code implemented will allow the user to enter in their exact amount of pet food desired to dispense to the bowl for that specific pet. This will directly correlate with how much food is dispensed, as well as the feeding time.

2.0 Project Description

The Opto-Smart pet feeder is a new type of pet feeder that employs the use of both optics and electronics to automatically feed the users pets when they are not around. Instead of worrying about getting home in time to fill a bowl users can breathe easily knowing their pooches and kittens are not being neglected.

This section contains:

- The background of the project.
- The goals and objectives during the starting design process of the device.
- A motivation discussion section detailing the influences the members had on choosing to work on this project.
- A specification list showing the necessary requirements and core, advanced and stretch features of this project.
- Marketing specifications listed inside of a house of quality diagram.
- Functional diagrams detailing how the optical components of this design will operate.

2.1 Project Background

In households with pet owners must be creative to make sure that their animals are fed every day and that they are keeping a routine schedule. When things come up in life such as working late or an unforeseen event, man's best friend may wind up being neglected. When this happens the pet owners' options are limited, they can either overfeed their animals which may lead to obesity and poor health or pick up an automatic pet feeder.

Another common problem in a household full of multiple pets is ensuring all pets are equally fed. Many times, one pet will rush to the pet bowl to eat their own serving as well as their sibling's dinner.

Many pets also have prescription food or medication. It is very important that the correct pet gets their full dose of medication. It can also be very dangerous if another animal gets hold of that medication. Owners need a way to ensure that they know which pet is eating out of which bowl.

Wet pet food is a healthy solution for many animal owners. One downside to it is that many times, if a pet is not quick to gobble down its food, it will harden. This will in many cases make the picky eater even less inclined to eat the meal. By having a lid on the bowl, the food will stay fresher longer. Making both the pet and owner happier.

An automated pet feeder can take the worry out of feeding a pet by dispensing food at the proper time each day. The only thing that the user must do is to make sure that the dispenser is filled with food when it starts to run low. These devices can take many forms from pre sized individual bowls that can open at a given time, to something more complex with motors, gears, belts, and Bluetooth functionality. One thing that these designs lack is the ability to feed multiple animals from one device.

In this project we want to take the principal idea of an automated pet feeder and add optical components to it to allow the pet feeder to “know” the difference between pet A, pet B pet C, etc. and then dispense that specific pet food. This will work thanks to a collar tag that the pet will always wear and will emit a specific color of light that the pet feeder can detect. Each pet will be assigned a color by the user that will act as that’s pets’ identity to the feeding system. When the onboard camera detects the correct color at the correct time of day then that pets’ predetermined amount of food is dispensed.

We also want to make sure that other pets do not eat another pet’s food so we will add a lid atop the bowl that can open and close using infrared (IR) LED’s and photodiodes that that best detect IR light built into the pet bowl.

2.2 Objectives

With this project, our core objective is to create a product that feels simple and easy to use to the end user and to give a feeling of luxury through the smart use of the optical elements. The main objectives of this project will be:

- Take the Stress Out of Feeding Your Pet
- Recognize if a Pet is at its Bowl
- Distinguish the Differences Between Pets

2.2.1 Goals

The goal of the Opto-Smart Pet Feeder is to deliver a high-quality product that is easy for busy pet owners to use even when they’re away from their own home. Optics and Photonics will be used to recognize the pet and to further ensure that the owner’s pets are being properly fed out of their own bowl.

2.2.2 Motivation

In the United States, many families work long hours to make ends meet and sometimes man's best friend is left out of the equation. This can lead to pets' ether being underfed from neglect or being overfed by people looking to make up not feeding their pets for days at a time, with both scenarios leading to misery for the pet. This is a key motivating factor in

the design of this product. Not only to create something that can have a real-world impact but to also bring malnourished pets a better quality of life.

Pet feeders in general are mostly considered to be small plastic bowls that sit on the floor and the pet owner refills every day. Innovation is slow to come to this field, but it is starting to heat up with all the new “smart” devices flooding the market nowadays competing for space with all the other devices. The difference here is this device can make the difference between your pet going hungry or not. A device like this could be a step in the right direction for making sure that pets maintain a routine and stay happy. This device is not meant to completely replace the need to care for a pet, but to assist the busy workaholic type of person that sometimes works a double at the office.

This project allows us to demonstrate the knowledge each team member has learned here at the University of Central Florida. As well as showing that each team member can communicate effectively and to work as a team to accomplish a common goal this is a great experience to have before embarking on our future career paths. A mutual love for pets has also helped inspire us to create this project, we all have cats and dogs that would certainly benefit from a product like this. The hurdles and challenges presented in a project like this will be a fantastic experience for the “real world” projects we will encounter down the road. And a device like this one can change a pet's life for the better forever.

2.2.3 Design A

To design a pet feeder that integrates optics to identify targets to output predetermined user settings. Along with a computer-based program that allows the user to add, remove or edit various settings

2.2.4 Design B

To design a pet feeder that integrates optics to identify targets to output predetermined user settings. Along with an app-based program that allows the user to add, remove or edit various settings.

2.3 Requirement Specifications

The Opto-Smart pet feeder will be able to perform certain requirement specifications as shown in Table 1.

Table 1 Requirement Specifications

1	Detectable Colors	3
2	Detectable Object Distance	> 5 Feet
3	Power Consumption	< 100 Watts
4	Response Time to LED Detection	< 10 seconds
5	Dispense Time	< 60 seconds
6	Survive Exposure to Mist	> 60 seconds
7	Lid Closure Time after Pet leaves	60 seconds ± 10 seconds
8	Dispensed Food Amount	± 10% of User Inputted Amount

■ - Demonstratable specifications

The role assignments for group 9 are defined in the block diagram below, Figure 1.

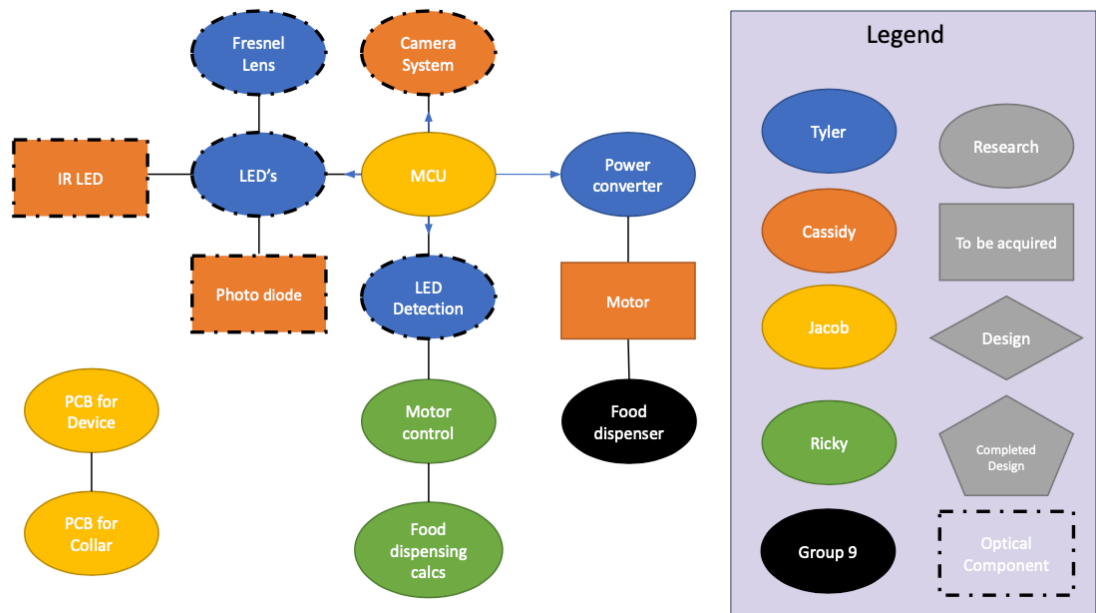

Figure 1 Opto-Smart Role Assignment Block Diagram

2.4 Features

This section contains the core, advanced, and stretch features for the Opto-Smart pet feeder these are the main functions of the project as well as features that may be implemented depending on the many constraints on the project that will be further discussed in section 7.

2.4.1 Core Features

The following core features of the Opto-Smart pet feeder will be major aspects in our design and drive our product.

- Identification collar tag that will open corresponding Opto-smart pet feeder lid
- Camera will identify LED color on pets' collar
- Self-closing lid once pet walks away from opto-smart pet feeder bowl that will open
- Food is delivered to bowl

2.4.2 Advanced Features

The advanced features outlined below will help elevate our project and show a higher level of design implementation.

- User configurable settings to adjust pet size and time of feedings

2.4.3 Stretch Features

The following stretch features may be implemented if time, budget, and capability enable. These features we would like to achieve if possible.

- Multiple pet bowls to be used by different pets
- Using a webcam for owners to watch pets while owners are out and about

2.5 Marketing and Engineering Requirements

This House of quality diagram shown in table 2 shows the relationship between the engineering challenges and the customer specifications for the Opto-Smart Pet feeder. Marketing requirements can be considered the size of the market, the type of clientele that you want to target and possible competitors (this is not an aspect of this project). Since there are many different products like this on the market, keeping certain goals in mind are important to ensure the highest quality product possible for the end user. House of quality tables are important to have during the planning stages of a new project and can keep track of the requirements set forth by the customer and the design team while staying aligned with the marketing requirements of the project. A strong house of quality can help reinforce the goals of the project and pursue what the customer has asked for in the product. [<https://www.aha.io/roadmapping/guide/requirements-management/what-is-a-market-requirements-document>]

Relationships	
Strong	●
Moderate	○
Weak	▽

Direction of Improvement	
Maximize	▲
Target	◇
Minimize	▼

		<table border="1" style="display: inline-table; vertical-align: middle;"> <tr> <td style="text-align: center;">+</td> <td style="text-align: center;">-</td> <td style="text-align: center;">+</td> <td style="text-align: center;">+</td> <td style="text-align: center;">+</td> <td style="text-align: center;">+</td> <td style="text-align: center;">+</td> </tr> <tr> <td style="text-align: center;">+</td> <td style="text-align: center;">-</td> <td style="text-align: center;">+</td> <td style="text-align: center;">+</td> <td style="text-align: center;">+</td> <td style="text-align: center;">+</td> <td style="text-align: center;">+</td> </tr> <tr> <td style="text-align: center;">+</td> <td style="text-align: center;">-</td> <td style="text-align: center;">+</td> <td style="text-align: center;">+</td> <td style="text-align: center;">+</td> <td style="text-align: center;">+</td> <td style="text-align: center;">+</td> </tr> </table>						+	-	+	+	+	+	+	+	-	+	+	+	+	+	+	-	+	+	+	+	+
+	-	+	+	+	+	+																						
+	-	+	+	+	+	+																						
+	-	+	+	+	+	+																						
		Column #	1	2	3	4	5	6																				
		Direction of Improvement	▼	▲	▼	▲	▼	▼																				
Category	Weight	Engineering Requirements	Cost	Response Time	Dispensing time	Detection Range	Power consumption	Product Size																				
Customer Requirements (Explicit and Implicit)																												
General Requirements	+	1) Ease of Use	●	▽	○	●	▽	▽																				
	+	2) Multiple pets	●	○	●	●	○	●																				
	-	Small Design	●	▽	○	▽	●	●																				
	+	Fast response time	○	●	●	●	○	○																				
	-	Fast delivery time	○	●	●	●	○	○																				
	-	Low power consumption	○	○	○	●	●	▽																				
Target			\$500.00	5 seconds	30 Seconds	~5 feet	< 100 W	Under 24" tall and 24" wide																				

Table 2 House of Quality diagram

2.6 Functionality of the Opto-Smart Pet Feeder

In the normal state, all the photodiodes will be activated by the IR LEDs and the lid will remain closed as shown in Figure 2. In this state, there is no pet at the bowl.

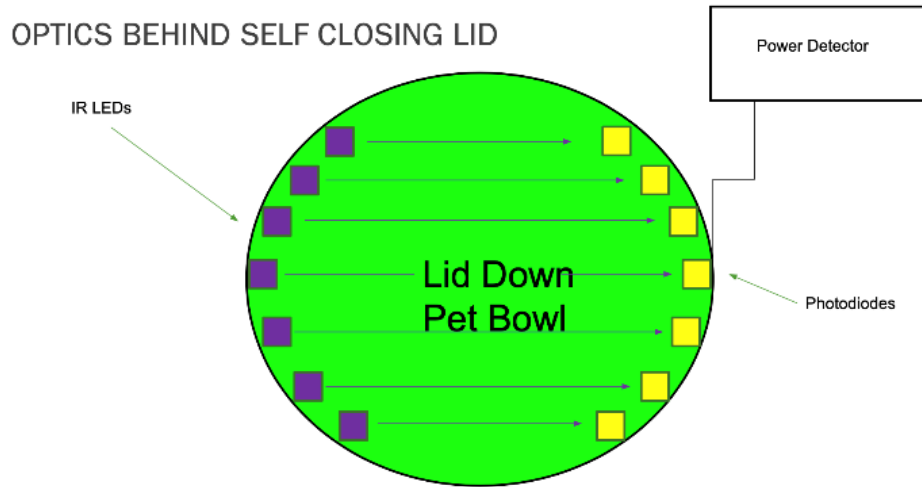

Figure 2 Opto-Smart Self Closing Lid Block Diagram

The Opto-Smart pet feeder will be able to detect when the designated pet enters the area. As shown in Figure 3, the collar will have an attached colored LED and Fresnel lens. The Camera system will then be able to pick up which color LED is shining and recognize which pet is entering the area.

OPTICS BEHIND CAMERA SYSTEM

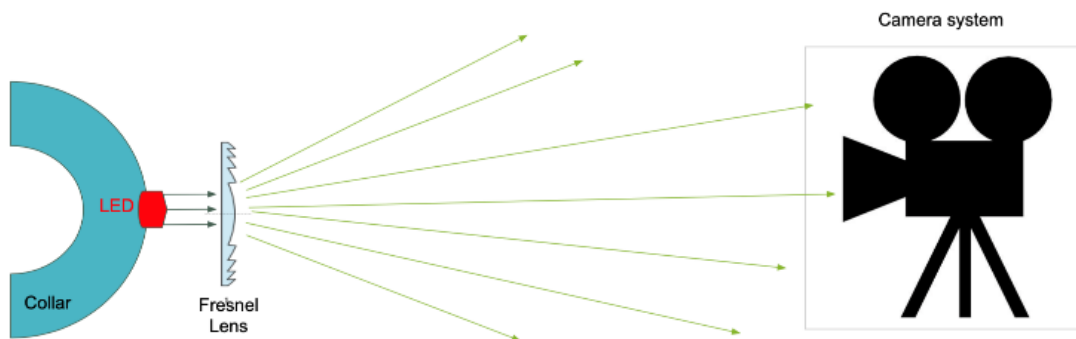

Figure 3 Opto-Smart Camera and Collar System

Once the camera system detects the pet waiting to get food, the lid will open. While the pet is eating, its head will block the signals of the IR LEDs. This will cause a drop in power detected by the photodiodes. This process is shown in Figure 4.

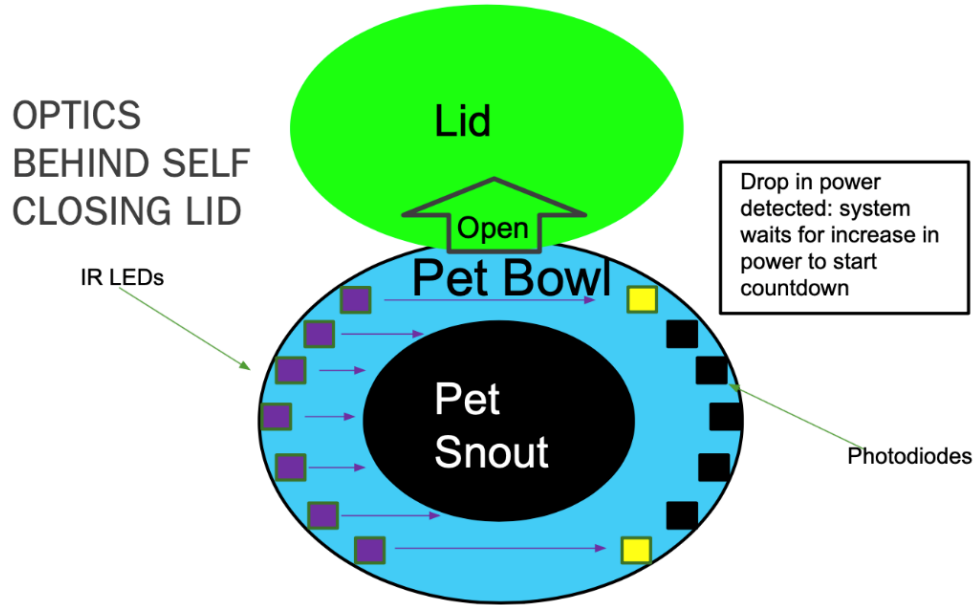

Figure 4 Opto-Smart Lid in Open Position, Activated by Pet

Once the pet is done eating, the photodiodes will gain an increase in power. This will start an internal countdown. If the photodiodes do not go through another drop in power before the timer is done, the lid will close. If the power does drop, the countdown process will repeat. This is highlighted in Figure 5.

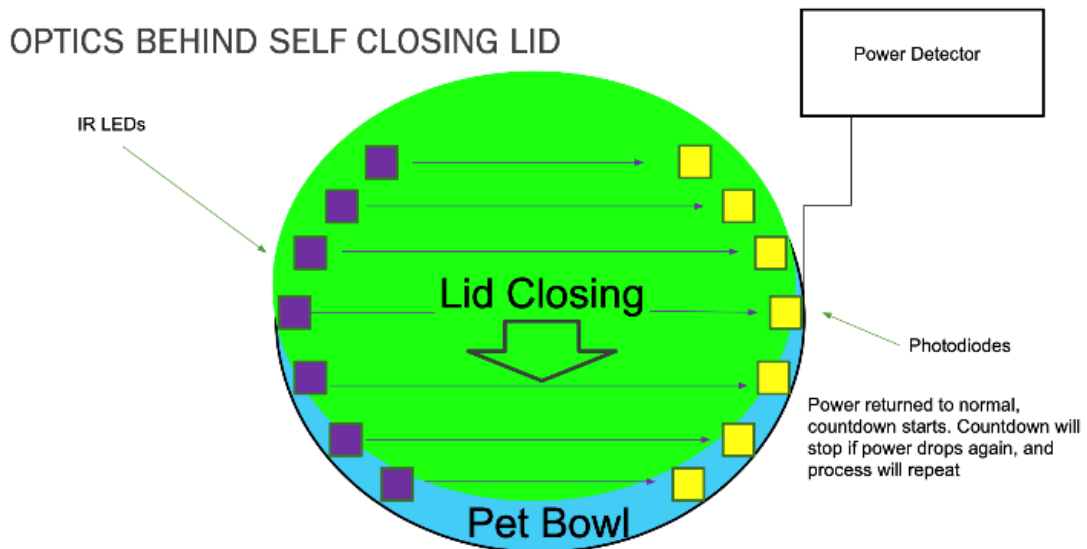

Figure 5 Opto-Smart Lid in Preparing to Close, No longer Activated by Pet

2.6.1 Website / App Functionality

The Opto-Smart Pet Feeder offers a webpage, and application functionality where users can remotely communicate with the device via Bluetooth, and Wi-Fi. This allows the user to remotely utilize the device to its maximum capability when they are on the go and away from their pets. The Opto-Smart Pet Feeder webpage first introduces the product to the user through its interactive homepage, presenting the product's features, explaining the product's goals and objectives, as well as further describing the creation team's overall motivation and drive answering the question "why are we creating this product?". After navigating through the homepage, users can direct themselves to either the sign-up page if they are a new user, or to the log-in page if they are a returning user. The new users must go through an online account registration process providing basic personal information such as first name, last name, email and password to create a secure online account associated with the product for users to access the Opto-Smart Pet Feeder functionality safely on the website. The online account registration is a very important part of the remote usage on our website, as the creation of the secure account will rightfully eliminate any hazardous and harmful security risks for all our online users. Once the online account registration process has been finished, with the user's email being verified, the new users and the existing users can now log into their newly created account which will direct them straight into the webpage dashboard that neatly displays all the Opto-Smart Pet Feeder's functionality for the users to fully control at their leisure. The application functionality for the users to utilize follows the same usage steps as the webpage, however, this application may be downloaded and used on your smartphone or tablet to make the remote access to the device conveniently accessible on your smartphone or tablet to all users.

3.0 Financial Considerations

Table 3 Component List

Component	Quantity	Total Cost Estimate
LED	1	\$6.99
Fresnel Lens	1	\$8
Camera	1	\$10
Photodiodes	6	\$105
IR LEDs	6	\$5.28
Power Meter	1	TBD
PCB Prototypes	TBD	TBD
Microcontroller Kit	1	\$120
Dispenser Motor	1	\$20
Battery (2032)	2	\$4
Mechanical Dispensing Parts	TBD	TBD
Dog Bowl	1	TBD
Total		\$279.27

With a current budget of about \$500, we have approximately 2300 left for further development of the Opto-Smart pet bowl. The prices listed above in Table 3 are estimated using online research. They may be adjusted slightly as the project gets closer to being produced. The final cost of the product will be evenly split between all the group members.

4.0 Research related to Project Definition

This section focuses on related research towards related technologies used with the Opto-Smart Pet feeder. This provides an opportunity to see an overview of the components and how they will function with the device.

The following section contains:

- A list of existing projects and projects pertaining to the development of the Opto-Smart pet feeder.
- An overview of the accessories and features related to the design.
- An overview of the general components used in the design

4.1 Existing Projects and Products

Automated pet feeders are not a new idea and there are those that perform either similarly or the same functions. There are existing technologies out there that can dispense food at predetermined times with very different design ideas.

4.1.1 Automated Feeder Design

There are many designs that employ the use of automation in a pet feeder. Because of this we know that it is possible to use motors and electronics to efficiently dispense food reliably each time.



Figure 6 Existing Automated Food Dispenser Design

Figure 6 shows a design that can dispense to two separate bowls at the same time. This feeder also allows the user to fill the device with up to 4 liters of food from the top. It uses gravity and some type of motorized dispenser to deposit food into the detachable bowl. This device runs on both battery and AC Power. The device also takes advantage of an app

to automatically dispense food remotely and to change settings. A voice recording feature is also employed to give your pets a personalized message to encourage them to eat from the feeder. This is very similar to how we would like our dispenser to function. Our design will be an elevated version of this as it will have a lid that will only allow the specific pet to eat from the bowl.



Figure 7 Existing Automated 5 Meal Feeder Design

Another design that we saw shown in Figure 7 used a motor that spun a tray around and could hold 5 meals for a pet. Each section holds one cup. Since this is a small feeding size, it is only recommended for extra-small breeds. The PetSafe Eatwell 5-Meal Automatic Dog & Cat Feeder is an interesting idea since it used a lid to cover up the food and allowed for portion control. And a quick and easy method to schedule meals using a very simple user interface consisting of 6 buttons and a double row liquid crystal display. The bowl automatically rotates to the next opening at a user designed time of day. It uses four D-cell batteries which will last up to a year. This design does not contain a lid that will recognize which pet is eating. It also only holds 5 cups, while ours will hold more than that.



Figure 8 Existing Automatic Feeder Design with Self-Opening/Closing Lid

An existing design that includes a mechanical lid is shown in Figure 8. The SureFeed Microchip Small Dog & Cat Feeder can detect the designated pet by either programmable microchip. It works with up to thirty-two pets. The food must be put into the feeder by the pet owner at each meal. The bowl lid will open when the correct pet is at the bowl and close as they leave. The time the lid takes to close can be adjusted for pet comfort as well as to ensure other pets are not sneaking in. The system uses four C cell batteries which should last for about six months. It is also only recommended for smaller pets and has a capacity of 1.6 cups. Contrary to our design the food does not automatically dispense the food into the bowl, and it can only be used for small pets.

4.2 Accessories



Figure 9 Existing LED collar design (Courtesy of puppykisses.com)

Figure 9 shows an LED collar tag for a dog that uses a small battery, an LED, and a plastic lens to disperse the light. This accessory is like what we want to create for our device to identify the users' pets.

4.2.1 Camera System



Figure 10 Example of color object tracking (Courtesy of roborealm.com)

The camera system that we will use will consist of a compact webcam that will fit inside of the feeder housing and record the environment and look for a specific color. This device will operate just as well in low light environments as environments with regular ambient lighting. This is due to the target being observed emitting its own light source. The camera will individually scan each row of pixels looking for a specific RGB value that is unique to each collar tag as shown in Figure 10. Technology like this is useful in several different fields. From defense products in planes and missiles to industrial machine lines for packaging and consumer level applications like in toys and smart devices. This is a useful feature that can operate efficiently with nothing but off the shelf components and code.

4.3 Relevant Technologies

In this section, a brief overview of the technologies that will be used with the device is given along with a brief explanation of how these different components operate.

4.3.1 Fresnel Lens

A Fresnel lens allows for a lens with a large aperture and a short focal length without the weight or the cost of a traditional lens. The Fresnel lens reduces the amount of material required to operate and is more cost effective compared to a simple lens. These lenses can be molded from plastic into a circular disk and then milled with a CNC machine to produce the ridges required to focus light. This is a boon to this project since it is a low-cost alternative to a simple lens and a lighter lens is a benefit to the pet since they will be wearing it all the time. One downside to using a Fresnel lens is that the image quality decreases so this would not be suitable for high quality images but works fine for simple light diffusion.

4.3.2 Photodiodes

Our design integrates photodiodes, a device that converts light into an electrical current. When photons are absorbed into the photodiodes current is produced. This is something that can be used to detect either the presence or the absence of light. These devices can be purchased to operate at specific wavelength and thus operate like a bandpass filter. The light we are planning to use is 950nm light that is just out of the visible and approaching the IR spectrum of light. Another benefit to this technology is low cost so many can be purchased to increase for this the best device to use would be a photodiode that best operates at or close to 950 nm. This is something vital that we need for this project.

Uses of Photodiodes:

- CD Players
- Medical Devices
- CAT Scanners – X Ray Detection
- IR Remote Controls
- Camera light meters
- Automatic Shutter controls
- Smoke detectors
- Automotive headlight dimmers

From this short list it is apparent that photodiodes have many advantages that help many of our electronics “see”. Photodiodes are the ideal low-cost option to determine the power output of this project.

4.3.3 LED’s

An LED is a semiconductor light source that can emit light when current flows through it providing a cheap, low power way to provide light to the device. These devices can be found in just about everything from flashing emergency lights to children’s toys. This is a device that can emit light for long periods of time without burning out like conventional incandescent bulbs or use toxic chemicals like CFL bulbs. This technology is perfect for the use of its previously mentioned advantages without the bulk or the hazards of other light sources.

4.3.4 Voltage Regulators

A voltage regulator can be used to convert a wide range of input voltages into a desired DC output voltage to be used to provide power to components within a circuit. There are multiple different variations of voltage regulators, including ones built with the use of diodes and separate integrated circuits that can be applied on their own. Voltage regulators are mostly utilized when there is a voltage input too large to be introduced into the circuit that is being analyzed. In this case, a voltage regulator can be used to convert the large voltage input into a smaller input that is a safe value for most microelectronics. Linear voltage regulator ICs are usually able to deliver a smaller output voltage from a large input voltage by dissipating the excess power as heat. This is normally an inefficient use of energy since most linear voltage regulators do not have a high efficiency value. Another type of voltage regulator is a switching voltage regulator which can convert the input voltage into the constant output voltage through the process of temporarily storing energy and then releasing it at the output (at an alternate voltage). Unlike the linear voltage regulator, the switching voltage regulator has a much higher efficiency value and can also usually accommodate a wider range of voltage inputs. These voltage regulators are perfect fits for applications in microelectronic devices, in which small, constant DC voltages are required to keep these devices safely within their recommended operating range.

4.3.5 Microcontroller

A microcontroller, also known as an embedded controller, is a small computer on a semiconductor integrated circuit. A microcontroller contains one or more processors along with RAM memory and a programmable input/output peripheral. There are several different types of microcontrollers available in the market today with different word lengths of 4bit, 8bit, 64bit, and 128bit. A microcontroller is manufactured to automatically control products and devices for them to function properly inside of an embedded system. Some examples of products and devices that contain a microcontroller are office machines,

robots, home appliances, motor vehicles, implantable medical devices, remote controls, power tools, toys, etc.

4.3.6 MOSFETS

Metal-oxide-semiconductor Field-effect transistors (MOSFETs) are elements that are used in embedded circuit design to help implement electronic switches and amplify various electronic signals. There are two types of MOSFETs, which consist of enhancement and depletion types. Enhancement mode MOSFETs have no conduction when at zero voltage. As the gate voltage is increased to a value greater than the source voltage, a wider channel (for charge carriers to flow) is established. Enhancement mode MOSFETs act similarly to an open switch, and a gate-to-source voltage is needed to “close the switch” and turn the device on. Depletion mode MOSFETs act oppositely to enhancement mode MOSFETs, in that a gate-to-source voltage is need to “open the switch” and turn the device off. In contrast to enhancement mode MOSFETs, depletion mode MOSFETs act similarly to a closed switch. MOSFETs are a common choice for low-power motor-driving applications since they can be safely used at low voltages and currents. Additionally, MOSFETs can also provide relevant function at higher switching frequencies than other higher power options (such as Insulated-gate bipolar transistors).

4.3.7 DC Motor

DC motors are a simple type of motor that deliver a torque that is proportional to the current applied, and the rotational speed of the motor is proportional to the voltage that will be applied to the motor. These motors can be used in applications such as camera lenses, actuators, and instrumentation devices. At low speeds, DC motors can mostly provide better performance than their AC motor counterparts. Low-power DC motors have applications in PC hard drives and similar devices such as DVD players. Additionally, DC motors can be separated into brushed and brushless variants. Brushed DC motors make use of a set of brushes and a commutator which are replaceable parts that can also be worn down with continued use. Brushless DC motors are operated by switching the driving transistor on and off, instead of using a commutator and brush system. No replaceable brushes are utilized in the brushless design, making them more maintenance free and reliable.

5.0 Research and Part Selection

This section will discuss the research that was done to ensure that the best parts are selected for our desired resulting product. By doing thorough research on each part we select, we can make sure that our product will function as we expect it to. The best chosen part from each of these sections will be further outlined in section 6.0.

5.1 Bowl and Lid System

The Opto-Smart pet feeder will be able to be used by all pets, regardless of breed or size. This means the bowl must be the appropriate size to be able to hold enough food to feed a

large dog. It also must be able adjust heights to allow the pets to be able to comfortably eat out of their bowl. The system to open and close the lid must also be optimized. The research done to ensure the parts are appropriately decided is described below.

5.1.1 Food Holder

The bowl capacity must exceed the amount of food needed for a large dog to allow the system to be compatible for all size pets. While the amount of food needed may vary by brand of food, age and type pet, for example the Purina suggested feeding amounts are specified in Table 4. For this section, we are only considering the larger sized animals, as smaller pets can still eat out of a large bowl. The bowl must be large enough to hold enough food for extra-large dogs. If the estimated extra-large dog is about 150 lbs, this correlates to about a 5.5 cup feeding amount. There must also be a margin of capacity within the bowl to keep it from overflowing or getting clogged.

Table 4 Dog Feeding Chart

Adult Dog Size (lbs)	Dry Food Feeding Amount (Cups)
3 to 12	1/3 to 1
13 to 20	1 to 1/3
21 to 35	1-1/3 to 2
26 to 50	2 to 2-2/3
51 to 75	2-2/3 to 3-1/3
76 to 100	3-1/3 to 4-1/4
100+	4-1/4 plus 1/4 cup for each 10 lbs of body weight over 100 lbs

The bowl will be made of stainless steel as it is the easiest to clean and is also durable and unlikely to break.

The food bowl will be a height that will be comfortable for pets of all heights to enjoy or at the very least be able to be integrated into any size system. Elevated feeding bowls can help aid in digestion and reduces stress on bones.

The system must also be stable and able to handle the weight of the dispensing system. An additional stand or weight balancing addition could possibly be needed and added.

5.1.1.1 Pet Zone Designer Diner Adjustable Elevated Dog Bowls

The Pet Zone Designer Diner Adjustable Elevated Dog Bowl shown in Figure 11 is sold on Amazon for \$29.95. It has three adjustable heights including 12 inches, 8 inches, and 2.75 inches. This design features enables it to be used for any size dog. This type of design allows for a puppy to grow with the system. It also has the potential of lasting longer for pet owners as it can be integrated between different pets if needed even if they are different heights. This design includes two bowls for water and food. It easily can be adjusted between heights and also is collapsible so it makes it easier for storage. The bowls are made from stainless steel which is easier to clean. It is also dishwasher safe and rust resistant. It can hold up to 56 oz. or 7 cups of food. This is in line with the ideal bowl sizing discussed in section 5.1.1. The bowls dimensions are 20 x 10.63 x 6 inches.



Figure 11 Pet Zone Designer Diner Adjustable Elevated Dog Bowl

5.1.1.2 IRIS Elevated Dog Bowls - Elevated Dog Feeder

The IRIS Elevated Dog Bowls Elevated Dog Feeder as shown in Figure 12 is sold for \$24.99 on Amazon, which is cheaper than the bowl in 5.1.1.1. It has two adjustable heights including 12.25 inches and a shorter option for small dogs. The legs are easily adjusted to change the heights. This great for growing with your pet but also has less variation than the bowl described in 5.1.1.1. It's dimensions are 21.25 x 11.5 x 12.25 inches. It has two stainless steel bowls that are dishwasher safe. The bowls hold two quarts which is equal to 8 cups. It has an outer rim which helps it to contain spills.



Figure 12 IRIS Elevated Dog Bowls - Elevated Dog Feeder

5.1.1.3 Adjustable Wood Dog Bowl Stand

The adjustable wood dog bowl seen in Figure 13 is on-sale on Amazon for \$9.99, which is significantly cheaper than the systems previously described. It has three adjustable heights, 3.9 inches, 7.9 inches, and 11.9 inches for all pet sizes. It is made from solid wood. It includes stainless steel bowls which are dishwasher safe and food grade material. The wood is shaped in a cute bone shape and the bowls include ears to look like a bear, this adds a design bonus. The dimensions are 16.5 x 9.7 x 13.9 inches. The bowls hold 60 ounces, which is approximately 7.5 cups. The bottom of the bowl includes anti-skid and slip material to help keep the bowl sturdy.



Figure 13 Adjustable Wood Dog Bowl

5.1.1.4 Gofetch Stainless Steel Pet Food Bowl with Double Diner

Another choice for our bowl selection is using a more simplistic design as shown in Figure 14. It is sold on Walmart.com for \$6.97. This design just includes two bowls and cannot be adjusted as previous bowl sets. It is 11.5 x 6.38 x 2.66. It would be a size sufficient for small dogs, but it can be used as a proof of concept as the system in the future could be transitioned into a bigger, taller bowl. It also would be simpler in integrating the food dispenser as the food holder could rest on the ground and wouldn't need to be adjusted with the bowl height.



Figure 14 Gofetch Stainless Steel Pet Food Bowl with Double Diner

5.1.2 Lid

The lid of the pet bowl will be designed so that it does not interfere with the food dispenser and so that it opens with ease. It will be 3D printed so that we can design the shape to ensure that it fits with the other components in our design.

5.1.2.1 Lid Motor

The lid will need a motor to rotate it open and closed. The Raspberry output is not strong enough to power a motor separately so it will need an external power supply to make sure the board is does not get destroyed while trying to power the motor. Motors are powered in a direction based off the direction of the current, which means an additional chip must be used. An example of this motor control scheme is shown in Figure 15.

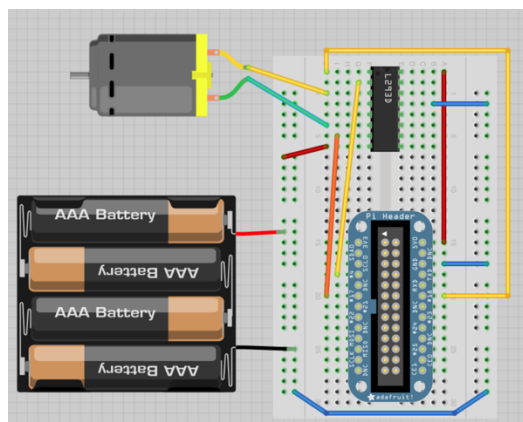

Figure 15 Motor Controlling Scheme

(Photo taken of <https://learn.adafruit.com/adafruit-raspberry-pi-lesson-9-controlling-a-dc-motor/lm293d>)

5.1.2.1.1 Bridgold L293D Chip

The Bridgoid L293D shown in Figure 16. A pack of ten is sold on Amazon for \$8.49. The chip can be used to help shift the direction of the current in the motor to change the rotation direction. The absolute maximum ratings for the L293D chip are shown in Table 5. It has a single channel output current of 600mA and can be used in applications of up to 5 kHz.

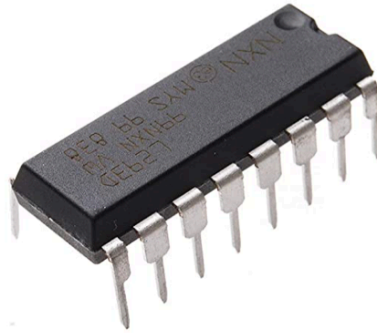

Figure 16 Bridgoid L293D

Table 5 Bridgoid L293D Ratings

Symbol	Parameter	Value	Unit
V_S	Supply Voltage	36	V
V_{SS}	Logic Supply Voltage	36	V
V_i	Input Voltage	7	V
V_{en}	Enable Voltage	7	V
I_o	Peak Output Current (100 μ s non repetitive)	1.2	A
P_{tot}	Total Power Dissipation at $T_{pins} = 90\text{ }^\circ\text{C}$	4	W
T_{stg}, T_j	Storage and Junction Temperature	- 40 to 150	$^\circ\text{C}$

5.1.2.1.2 HiLetgo ULN2003 4-Phase Stepper Motor with 5V Drive Board

The HiLetgo ULN2003 4-Phase Stepper Motor with 5V Drive Board is sold on Amazon for \$13.99. It comes in a 5-pack. It is a 5 Volt motor and is 28mm in diameter. Its stepping angle is $5.625 \times 1/64$. This is compatible with both the Raspberry Pi and the Arduino.



Figure 17 HiLetgo Stepper Motor with Drive Board

5.1.2.2 Three-Dimensional Printing

To be able to fully customize our design, 3D printers may be used to print the lid. This will allow it to not interfere with the other components of the design. The options for choosing a 3D printers are described below.

5.1.2.2.1 Texas Instruments Innovation Lab at UCF

The Texas Instruments Innovation Lab at has a 3-D printer we could potentially use. The lab is open 10 am – 6 pm Monday – Friday. A flash drive must be provided, and the form should be in a .DXF file. It has a 3D printer that is free to students, but material must be provided. It also has a Universal Laser Cutter that can be used to cut through acrylic and wood.

5.1.2.2.2 Lockheed Martin IDEA Lab

Lockheed Martin MFC has 3D printers available to employees. It is completely free and they provide the material. The printers are relatively small, so they would not be able to be used for anything too large. They also are busy and operate at a first come first serve basis. It is a little less convenient than the innovation lab but is also slightly cheaper.

5.2 LED

This project will use an LED as part of the detector system (not to be confused with the pet collar tag LED system that is discussed in section 5.5.3) that will have a wavelength at or around 950nm. This is just outside of the visible light spectrum and will be completely invisible to the user and the pet. IR light is completely harmless being emitted from a low powered LED; this is the same type of component found in television remotes. Multiple LED will be positioned inside the perimeter of the dog bowl, forming a semi-circle.

5.2.1 LED Equations

$$\frac{V_{in} - V_{LED}}{I_{LED}} = R_s$$

Equation 1 LED Voltage Equation

5.2.2 IR LED Options

As discussed before, the Opto-Smart pet bowl team have chosen to use an IR LED that will emit light at or around 950 nm. This wavelength was chosen due to its abundant use in many electronic devices such as television remotes, and optical mice. Many options are readily available to purchase online through sources such as Amazon, Mouser Electronics, Digikey or many other sources. There are many different models being offered that all

perform slightly different. The key to this project is to pair the IR LED's to operate with the photodiodes with the highest efficiency possible.

5.2.2.1 NTE30048

This is an IR LED that emits light at 850 nm, a maximum operating current of 50 mA, a forward voltage of 1.4V, a cost of \$0.71 per unit, and a diameter of 5mm. The cost of this model is appealing since the team can buy several of these LED's for a small cost. This is the cheapest LED that fits the parameters our team is looking for. One drawback to this is the LED is emitting light at 850 nm which is much closer to the visible spectrum. This can lead to more noise being picked up in the system and could potentially cause issues detecting objects. The operating current of this device is also small, this may be a disadvantage depending on how the PCB is designed. The size of this LED is within the specifications of our design.

5.2.2.2 SFH 4546-AWBW

This is an IR LED that emits light at 950 nm, a maximum operating current of 100mA, a forward voltage of 1.4V, a cost of \$0.87 per unit, the diameter of the component is not listed. This LED fits much closer to the specifications of the project compared to the LED mentioned in 5.2.2.1 The LED has a viewing angle of 40 degrees. the LED is emitting light at the target wavelength, has a higher operating current, to allow a greater intensity of light to hit the detector (photodiode). The cost of the component is higher than the LED mention in 5.2.2.1 the cost difference is \$0.16 which is negligible.

5.2.2.3 MTE9460N5

This IR LED emits light at 950 nm, has a maximum operating current of 100mA, a forward voltage of 1.3V, a cost of \$6.21 per unit, the diameter of the device is not listed the LED has a viewing angle of 20 degrees. This LED is much more expensive than the other LEDs listed in 5.2.2.1 and 5.2.2.2 the advantage of this device is the narrow viewing angle compared to the other LED's listed this is advantageous due to more light being able to focus into the photodiodes. The disadvantage of this product is its cost since multiple LEDs need to be purchased for this project.

5.2.3 LED Comparison

Table 6 LED Comparison Chart

	Wavelength (nm)	Operating Current (mA)	Forward Voltage (V)	Viewing Angle (deg)	Cost
NTE30048	850	50	1.4	40	\$0.71
SFH 4546-AWBW	950	100	1.4	40	\$0.87
MTE9460N5	950	100	1.3	20	\$6.21

As stated in Table 6, the clear winner here is the SFH 4546-AWB. The NTE30048 is the cheapest of the lot but a lot is sacrificed since this LED is emitting 100nm short of what this project requires. This LED also has half the operating current compared to the other LED which would cause the LED to emit less light compared to the other LEDs being considered. The MTE9460N5 is closer to what we are looking for in an LE since it emits light at 950 nm. It also has a narrow viewing angle that focuses light into a narrower beam which may make power detection easier. The cost of the device is the main downside since it is several times more expensive than the other two options. This leaves SFH 4546-AWBW as the prime choice to use for this project for its low cost, the wider viewing angle should not affect the quality of the device since multiple LEDs will be used.

5.3 Photodiode



Figure 18 Example of a Photodiode

(Courtesy of Newark.com)

These photodiodes have been specifically chosen to detect light at 950 nm, which means these photodiodes operate most efficiently at 950nm or thereabout. This will create a bandpass filter for the device and cut down excess noise from different wavelengths of light. Since the photodiodes are on one side of the bowl and the LEDs are on the other side this creates a sort of “trip wire” system that can detect an either the presence or the absence of an object through a change in voltage. As mentioned in the diagrams in section 2.6, the

photodiodes and LEDs are responsible for the lid of the automated pet feeder. By constantly measuring the difference in voltage the system during feeding time the microcontroller can establish a normal (average) voltage that the system sees when that average drops the system then determines that an object is blocking the light leading to the photodiodes and initiates a flag in the system. Once the voltage raises (returns to average) a countdown is triggered and the lid closes if a voltage drop does not occur. If a voltage drop occurs, then the system restarts, and the countdown stops. One problem that must be addressed is the height and positioning of the photodiodes and the LEDs inside of the bowl. Too low and the detectors will always be blocked by the pet food, and too high will cause excess noise to be detected by the system and lead to false positives in voltage and cause unintended openings, closures and restarts in the system.

5.3.1 Photodiode Equations

For this project, photodiodes will be operated with a reverse bias voltage to increase both the depletion width and the electric field to improve the quantum efficiency and the speed of the response. The equations listed below are important to this project for determining the photocurrent and the responsivity of a photodiode.

$$I_{ph} = \eta_{Overall} \frac{Q P_{opt}}{h f}$$

Equation 2 Photocurrent

$$I_{total} = -I_{ph} + I_s \left\{ \exp\left(\frac{qV_{diode}}{k_B T}\right) - 1 \right\}$$

Equation 3 Total Photodiode Current

$$R = \frac{I_{ph}}{P_{opt}} \text{ (A/W)}$$

Equation 4 Responsivity of a Photodiode

5.3.2 Photodiode Options

As previously discussed in section 5.2 the Optosmart Pet feeder will use an LED that emits at 950 nm, for this design we need a photodiode to detect the light that is emitted from those LEDs. What we are looking for in a photodiode is low cost, a low dark current, and a fast response time. Another thing to consider is whether to use a PN photodiode or a PIN photodiode. A PN photodiode would be cheaper than a PIN photodiode but has a poor response time when it is reverse biased. Since we are looking more for a better response than the cheapest option on the market PIN photodiodes will be considered for this project.

5.3.2.1 S2386-5K

This photodiode has a peak sensitivity In the IR spectrum at a wavelength of 960 nm. This wavelength is close to what the OptoSmart Pet feeder team is looking for in a photodiode. It has a dark current of 5 pA, which can be considered negligible for this product since we are trying to detect around 100 mW of power. Each unit and costs \$13.98 per unit. This price is within the budget for the OptoSmart pet feeder projects budget.

5.3.2.2 BPV23FL

This photodiode, sold by Mouser Electronics has a peak sensitivity of 950 nm. This wavelength matches what the OptoSmart Pet Feeder team is looking for in a photodiode. It has a dark current of 2nA, a reverse voltage o 60V, a rise time of 70 ns, a fall time of 70ns, a forward current of 50 mA, a forward voltage of 1V and a responsivity of 0.6 A/W. the price per unit is \$1.03 which fits nicely into the budget of the OptoSmart Pet feeder budget.

5.3.2.3 BPW82

This photodiode, sold by Mouser Electronics has a peak wavelength sensitivity of 950 nm. This matches wavelength matches what the OptoSmart Pet Feeder team is looking for in a photodiode. It has a dark current of 2 nA, a reverse voltage of 60V, a rise time of 100ns, a fall time of 100ns, a photocurrent of 45 uA. A forward current, forward voltage and responsivity was not listed on the website. This unit has a price of \$1.07 per unit

5.3.3 Photodiode Comparison

Table 7 Photodiode Comparison Chart

	Peak Wavelength Sensitivity (nm)	Dark Current (nA)	Reverse Voltage (V)	Rise Time (ns)	Fall Time (ns)	Photo current (uA)	Responsivity (A/W)	Cost (\$)
S2386-5K	960	.005	-	-	-	-	-	\$13.98
BPV23FL	950	2	60	70	70	-	0.6	\$1.03
BPW82	950	2	60	100	100	45	-	\$1.07

The photodiodes listed here all have clear advantages and disadvantages. The first thing is price, BPV23FL is the cheapest photodiode listed here all while having a better rise and fall time compared to BPW82. The price between photodiode 2 and 3 are negligible so BPV23FL is slightly better than BPW82.S2386-5K is the most expensive photodiode with a dark current much smaller than either of the other choices of photodiodes but its peak wavelength sensitivity is 10 nm off from what we are aiming for in this project. The winner here is BPV23FL for its price and slightly faster rise and fall times compared to the device of similar price.

5.4 Printed Circuit Board (PCB)

With modern electronics it is hard to find a device that does not use a printed circuit board (PCB) to assemble electric circuits. A PCB is the bridge between support for the physical components and a connection link for the components. PCBs can be either very simple with as little as one or two layers of copper or can serve in high density applications with more than 50 layers. A PCB uses pads that are usually made of copper but could be any conductive material (like gold) to link various components together to create an electrical system that allows the various components to work together to serve some type of function. These traces can either be printed onto a PCB or they can just be wires soldered directly from one component to another. Along with the conductive traces the PCB also serves to insulate the components from one another to prevent unwanted connections or “shorts” using a non-conductive material. All of the unwanted voltage and current must flow somewhere, so the PCB must also have a ground to protect against high voltage through the system and eliminate excess noise. For this project, several different PCBs may have to be created to serve different purposes.

5.4.1 Designing a PCB

A quality PCB is crucial for the OptoSmart Pet Feeder not only for peak performance but to ensure a long lifetime for the product. It is paramount that the OptoSmart Pet Feeder team designs a quality, long lasting PCB. While each PCB design can differ wildly, many of the approaches to the design remain the same. By following this methodology each PCB that is designed and implemented into the design meets the same quality standards that the end user can know and trust that their product will work every time. The techniques listed below gives a brief overview of recommended steps and techniques to follow when designing a PCB.

5.4.1.1 Determine what the PCB needs to do

The first step to this process may seem intuitive but it is important to understand what you are looking for out of your PCB design. Create a list of things that need to happen to achieve your desired effect and create a table of how many components are being included in the design. Also consider the size of the components you are thinking of using and where they should be placed on the board. Several large components, such as large electrolytic capacitors or a transformer should be spaced out wherever possible. This is a good time to see the specifications of those components. In the case of the OptoSmart Pet Feeder, one PCB that must be created is the PCB that controls the functionality of the pet collar (the system that activates and powers the LED attached to the pet collar). This PCB will need to include a portable power source (battery) and a way for that battery to deliver a current to the LED attached to the PCB whenever the battery is switched on. The size of this PCB will also need to be small enough to reduce annoyance to the pet wearing the collar (approximately less than 5 square inches in area).

5.4.1.2 Pet Collar PCB Battery Selection

The PCB to be implemented within the pet collar will be a relatively small circuit board that is able to deliver power to an LED so that the chosen camera module can detect the color emitted from the LED. To send power to the LED through the PCB a small battery must be selected that is able to deliver the correct amount of voltage and current without weighing the collar down too much. Since the LEDs that will be used for the collar do not exceed a 3V forward voltage, three different compact sized 3V batteries can be compared. The choices for a viable battery are shown in the table below:

Table 8 Pet Collar PCB Battery Comparison

	Model Name	Maximum Operating Voltage (V)	Dimensions (D x H in mm)	Weight (g)	Capacity (mAh)	Cost (\$/battery)
B00L4EEQCY	CR2025	3	20 x 2.5	2.6	≈ 170	≈ 1.3
B07GN8ZYZR	CR2032	3	20 x 3.2	3	≈ 235	≈ 1.5
B07JLN1WXT	CR1632	3	16 x 3.2	1.8	≈ 130	≈ 1.4

According to the table above it is apparent that the only major differences between these batteries is size and capacity. Since only a single battery will be used to power the LED within the collar's PCB, the price differences are almost negligible (the prices can also fluctuate depending on the quantity ordered and time/location of purchase). In addition, all three batteries contain capacities that would be able to keep the low power LED on for at least multiple months at a time. The most important criteria in this case would be the size and weight of the battery, since a lightweight design is the main goal (and most beneficial to the pet that will be wearing the collar). The CR1632 seems to be the most optimal choice when it comes to both size and weight, since this battery has the smallest diameter while weighing almost half that of the CR2032.

5.4.1.3 Pet Collar PCB Development Software

The software that we are planning to use to design the PCB for the pet collar will be Autodesk EAGLE, since it is a fully functional software that allows both schematic and PCB creation and is what most of the team members are comfortable using (from prior class experience). The EAGLE software will allow our team to develop a PCB using the components (LED and battery) that were selected to be most optimal for the development of the pet collar. This software will be used to import the exact parts chosen for the battery and LED selection and connect them virtual with the schematic creator. A PCB board layout will then be developed from the schematic and proper trace routing and grounding protocols will be followed before sending the final PCB design to be physically implemented. There will be no additional cost required for access to EAGLE, since the education edition is available to students at no extra fee.

5.4.1.4 PCB Development Costs

To have the PCB fabricated from the design that will be developed using EAGLE, we will use an online PCB fabrication company that is able to manufacture and deliver multiple copies of a custom PCB in a short amount of time. An approximate cost for 5 units of a PCB at a size of less than 5 square inches (127 square millimeters) seems to be between \$20-\$35 with shipping included. Once the design of the pet collar PCB schematic is complete and the components have been tested using a breadboard (to ensure compatibility and functionality) the PCB cost should ideally be a one-time fee that results in a PCB that will be able to be easily implemented into our design of the pet collar.

5.5 Pet Collar System

The pet collar will consist of a normal collar. Our design will be able to be integrated into any size collar so that pets of all sizes can use it. Each pet in the household will need to have a different color LED. The Fresnel lens will disperse the light in order to allow the camera to be able to more easily identify the LED color. The following sections will describe the research done to decide between using one collar with a tri-colored LED, or three different collars each consisting of one color. It will also describe the research done on which Fresnel lens to choose.

5.5.1 Pet Collar

To save money we will use a pet collar that we have at home. The size of the pet collar does not matter as the functionality will be able to be integrated into any size dog collar. The device that we will be creating is a tag for the pet collar which is explained in detail below.

5.5.2 Lens System

We would like to design a lens that will help enhance the LED light that will be on the collar. This will allow us to increase the efficiency of the LEDs while not having to add more LEDs to the system.

5.5.2.1 Planoconvex Lens

A planoconvex lens is the most common type of lens used in optics. It is a lens that has one flat surface and one curved surface that allows for light to be focused, collected and collimated []. The two surfaces of the planoconvex lens work together by focusing parallel light rays to a focal point. Planoconvex lenses can be designed to have either long or short focal lengths to manipulate where an image forms and the magnification of the image. For the OptoSmart Pet Feeder having a short focal length in the image plane is advantageous since allows for light emitted by the LED to diverge from the lens and enable the camera system to identify the LED color more easily from a greater distance and a larger angle.

5.5.2.2 Zemax (Optics Studio) Calculations

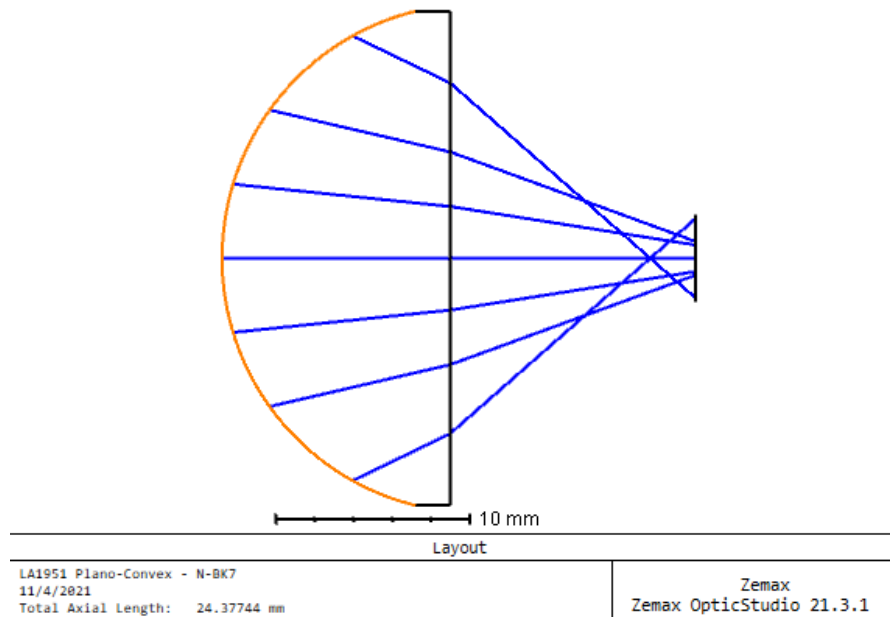

Figure 19: Layout of Plano-Convex Lens

The pet collar tag for the OptoSmart Pet Feeder must be small enough to comfortably fit on a pet's collar without the device being cumbersome for the animal. We are limiting the size to be no larger than a diameter of 1.5" and a depth of 2" while allowing the light from the LED to diverge. These factors were plugged into Zemax and we have determined that the LED would need to have a viewing angle of no less than 40 degrees and would sit at a maximum of 20 mm away from the lens in order to maximize the amount of dispersed light from the tag. By doing this the LED would not need to be as bright as it would need to be without the lens and in the process saves battery power. A spot diagram was also taken of this lens system to determine the uniformity of the light passing through the system, and it was determined that the uniformity of light at the distances needed for this project is acceptable. It is also important to mention that since we will be using three different wavelengths for this project

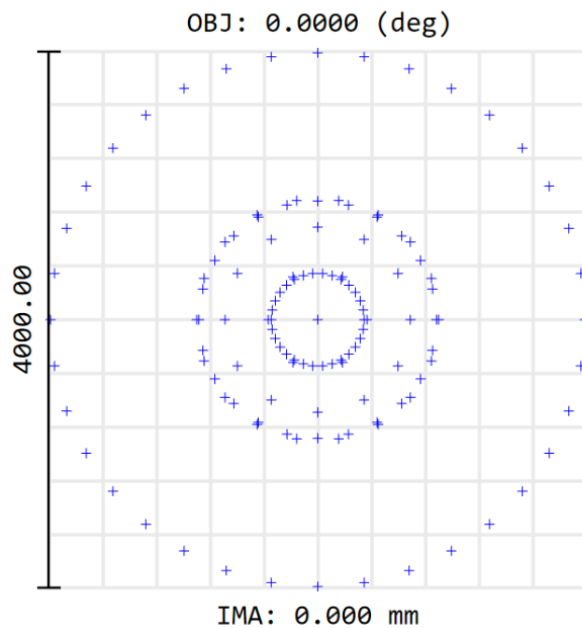

Figure 20 Spot diagram of plano-convex lens

5.5.2.3 LA1951 – N-BK7 Plano-Convex Lens



Figure 21: LA1951 Lens from ThorLabs

From the calculations in section 5.5.2.2 The OptoSmart Pet Feeder team is looking for a plano-convex lens with a focal length of 25mm and a 1inch diameter. Since this lens will be used for three different wavelengths no AR coatings are necessary. The LA1951 (seen above) meets the criteria of the project at a price of \$25.14 per lens. This is the lens that matches the parameters of the project the closest and at the lowest price, so this will be the only lens considered for this project.

5.5.2.4 Fresnel Lens

Fresnel lenses are made up of concentric circles which can take light and turn them into a narrow beam. This concentrates the light and allows it to be focused on a certain direction as shown in Figure 22. Fresnel Lens have a short focal length so it can be relatively close

to the LED in the collar which would help with keeping the collar more compact. Fresnel lenses tend to be made of plastic which allows them to be less expensive, more durable, and lighter. Fresnel lenses can be used for light collimation, light collection, and even magnification. Theoretically a Fresnel lens can be created to have the perfect dimensions and focal length for a given distance but in reality this is very difficult to do due to the nature of the material that Fresnel lenses are made of (plastic) for the purposes of this project it would be difficult to find a Fresnel lens that would match the focal length and dimensions we need off the shelf. If the device were to use a Fresnel lens it would need to be close to the dimensions required by the project and within a certain tolerance.

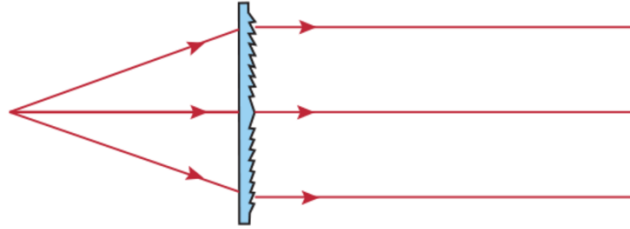

Figure 22 Fresnel Lens

5.5.2.4.1 Fresnel Lens Equations

$$P = \frac{n_{Lens} - n_o}{n_o} \left(\frac{1}{R_1} - \frac{1}{R_2} \right)$$

Equation 5 Lens Makers Equation

$$P = \frac{1}{f}$$

Equation 6 Fresnel Lens Focal Length

$$\frac{1}{\text{Object Distance}} + \frac{1}{\text{Image Distance}} = \frac{1}{f}$$

$$M = \frac{-\text{Image Distance}}{\text{Object Distance}}$$

Equation 7 Fresnel Magnification

$$\frac{I_R}{I_L} = R = \left(\frac{n_2 - n_1}{n_2 + n_1} \right)$$

Equation 8 Fresnel Loss

$$n_1 \sin \theta_1 = n_2 \sin \theta_2$$

Equation 9 Snell's Law

5.5.2.4.2 Shappy Thin Fresnel Lens Pocket Size Magnifier Lenses

Amazon sells a 20 piece pack of pocket size Fresnel lenses for \$9.59. The dimensions are 3.35 x 2.17 x .04 inches. It is made of PVC plastic material and is thin, bendable, and lightweight. It has a magnification factor of 3x.

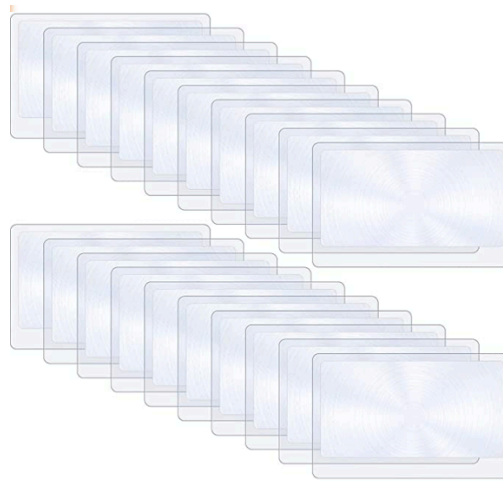

Figure 23 Shappy Fresnel Lens

5.5.3 Color LEDs

Light emitting diodes (LED) are devices that emit light when current flows through them. The color of the light emitted depends on the energy required for the electrons to cross the bandgap of the semiconductor. In the past, consumers were limited to single color long wavelength (red) LEDs that were inefficient to operate for long periods of time and had a low light intensity. Nowadays LEDs come in almost every color and have become much more efficient to operate when compared to other light sources. The size of the devices is also a boon to this project since the device emits a constant bright light and little heat. In this section we will research the advantages and disadvantages single color and tri-color LEDs and the process of creating three different collars with one type of LED or the other.

5.5.3.1 Single Color LED



Figure 24 Example of a single-color LED

LEDs come in a variety of shapes and sizes but for the OptoSmart Pet feeder we are looking for a small device that can easily fit in a device no larger a three-inch diameter and must not draw much power since the device will run on a single battery. This constraint rules out any type of incandescent light source since they can be large and draws too much power to have the light intensity we are looking for in our product. One device that would suit our needs for this project would be the LED. Since the device is small and operates more efficiently than conventional incandescent lighting this is a viable option for this project. An advantage to having a single-color LED is that it would be easy to integrate into a PCB since it is a low power device with only an anode and a cathode to solder to a board, this limits any errors that could arise from building the collar tag PCB. Another advantage of having a single LED is ease of use, since the tag is only capable of emitting one single color this eliminates any confusion of which color goes to which pet since the collar tag would only be capable of producing one color.

5.5.3.2 Single Color LED Options

There are almost limitless options on the market when it comes to single color LEDs due to the popularity of the component in modern electronics since these devices can be found in just about anything from medical equipment like status indicators in defibrillators, flashlights, and even children's toys. Though even though the market is saturated with them doesn't mean they are all built the same. Here is a comparison between a few different devices.

5.5.3.2.1 C5SMF-RJF-CT0W0BB2

This is a red LED from Mouser Electronics that emits light at a wavelength of 621nm. This LED also has a viewing angle of 40 degrees, a luminous intensity of 2200 mcd (millicandela), the forward current of the device is 20 mA, and the forward voltage is 2.1 V. It has a power dissipation of 130 mW. This LED costs \$0.14 per unit. This unit was chosen for its all-around qualities of not being great in any field. This LED has a wide

viewing angle with a standard luminosity at a price lower than the other two products being researched.

5.5.3.2.2 **RL5-R8030**

This red LED from superbrightleds.com emits light at 630 nm. The LED has a 30-degree viewing angle with a luminosity of 8000 mcd. The forward current for this device is 20 mA with a forward voltage of 2.2 V. This LED has a power dissipation of 80 mW and costs \$0.28 per unit. The advantage of this LED over the other two is the luminosity, this is three times brighter than the LED discussed in 4.5.3.2.1 and gives this at a narrower viewing angle. This would make seeing the light at a further distance easier without extra help of a lens to collimate the light

5.5.3.2.3 **MV50154**

This red LED sold by digi-key emits light at a wavelength of 660 nm. The LED has a 50-degree viewing angle with a luminosity of 1.5 mcd. The forward current of this device is 10 mA and the forward voltage is 1.6V. This LED has a power dissipation of 180 mW and costs \$0.34 per unit. This device is much dimmer than the other devices chosen to be researched, with this the device would draw less power from the DC power supply and rely more heavily on the Fresnel lens to ensure the system would be able to detect the color of the LED.

5.5.3.2.4 **Single Color LED Comparison**

Table 9: Single LED comparison

	Wavelength (nm)	Operating Current (mA)	Forward Voltage (V)	Viewing Angle (deg)	Intensity (mcd)	Cost
C5SMF-RJF-CT0W0BB2	621	20	2.1	40	2200	\$0.14
RL5-R8030	630	20	2.2	30	8000	\$0.28
MV50154	660	10	1.6	50	1.5	\$0.34

The LEDs that were listed in sections 4.5.3.2 all have clear advantages and disadvantages, a list of features of each LED can be seen in table 7. For this project the OptoSmart Pet Feeder team is looking for an LED that has a wavelength closely matching the desired color (for this instance we are looking at the color red. Blue and green will be discussed in depth during the design section of this paper).

5.5.3.3 **Multi Color LED**



Figure 25 Example of a Multi Color LED

Rather than relying on a single LED to for a single color a single LED can be used to display multiple colors. These LEDs are actually three different LEDs consisting of a red, green and blue LED combined into a single compact epoxy housing. A great advantage to this technique is that the current can be varied across the three separate colors to produce different colors. Another advantage of this technique is that this component has a much smaller profile compared to three single color LEDs paired closely together. The pinout of a multicolor LED differs from the standard single-color LED that consists of an anode and a cathode. These multicolor LEDs can have between four and six pins (the pinout for the device the OptoSmart Pet Feeder will use will have four pins so the remainder of this document will discuss this one). The LED uses either a common cathode or anode for all three LEDs and a cathode or anode just for red, green, and blue (see figure 18 for pinout diagram).

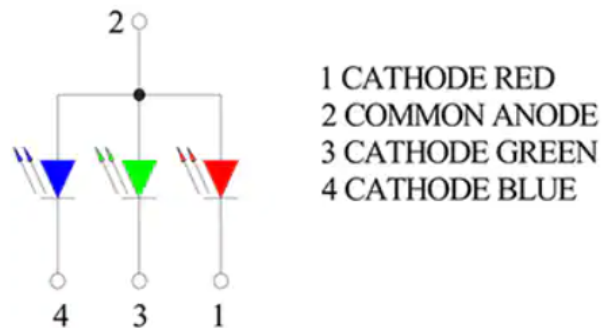

Figure 26 Pinout diagram for a Multi Color LED

(courtesy of digikey.com)

5.6 Camera System

The camera system will constantly be monitoring the area in front of the Opto-Smart pet feeder. When it identifies the designated bright LED, it will recognize the assigned dog that is trying to eat based off the color of the LED. Seeing the assigned color will activate the system to start the process of opening the lid. The process of choosing a camera that will be able to be integrated into our project will be described below.

5.6.1 Raspberry Pi Camera v2

The Raspberry Pi v2 Camera as shown in Figure 27 is sold by CanaKit for \$25. It is made by the company that makes the Raspberry Pi microprocessor, which will ensure it could be easily integrated. It supports up to 1080p. It is 8 megapixels with a resolution of 3280 x 2464 pixel static images. It is small, sizing at only 25 mm x 23 mm x 9 mm.

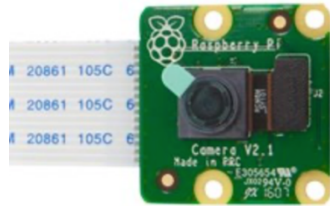

Figure 27 Raspberry Pi Camera v2

5.6.2 BBTO OV5647 Mini Camera Module

The two pack BBTO OV5647 Mini Camera Module is sold on amazon for only \$10.39. It is compatible with the Raspberry PI 4, 3, 3B+, and 2 models. It records in 1080P with a focus lens of 5 megapixels. It captures still images with a resolution of 2592 x 1944. It is small and compact with a size of 25mm x 24 mm x 9 mm. The Raspberry PI has small sockets, and this camera can be integrated into it. The way it can be attached to the Raspberry PI 4 via its 6-inch ribbon cable as shown in Figure 28. This set comes in a two pack which is perfect if we want to enact out stretch goal of creating a live feed video, as described in 2.4.3. It is also great to have a backup just in case the first one breaks. Costing an average of only \$5.20 each, it is a low cost, easily integrated option for our design if we choose to use a Raspberry PI Microprocessor.

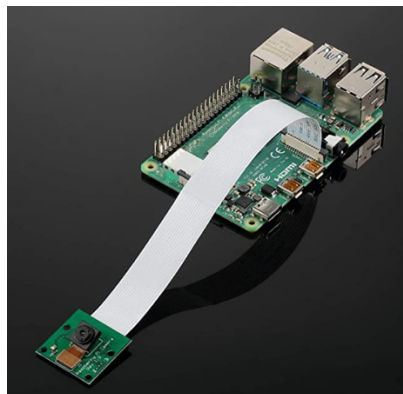

Figure 28 OV5647 Mini Camera Module

5.6.3 Ximimark USB Camera (LY096)

Another option to integrate the camera feature is to use the Model LY096 Ximimark USB Camera which is sold on Amazon for \$7.79. It is a USB camera whose focus can be adjusted on a computer but is able to be integrated into a Raspberry Pi microprocessor. It can be plugged into one of the USB ports on the Raspberry Pi as shown in Figure 29. It has a retractable cable so it saves space, yet also can be used at different distances. It is 640 x 480 p. It is 3.8 cm x 1.5 cm x 3 cm.



Figure 29 Ximimark USB Camera

5.6.4 Arducam Mini Camera Module (OV2640)

The Arducam OV2640 Mini Camera is sold on Amazon for \$25.99. It can be integrated into both a Raspberry Pi module as well as an Arduino board, which is useful if we decide to use the Arduino board. It has a 2 mega pixel image sensor and has a built-in IR block filter so that only visible light will enter the camera. The camera is 2 x 1.7 x 1.6 inches. It can be integrated as shown in Figure 30.

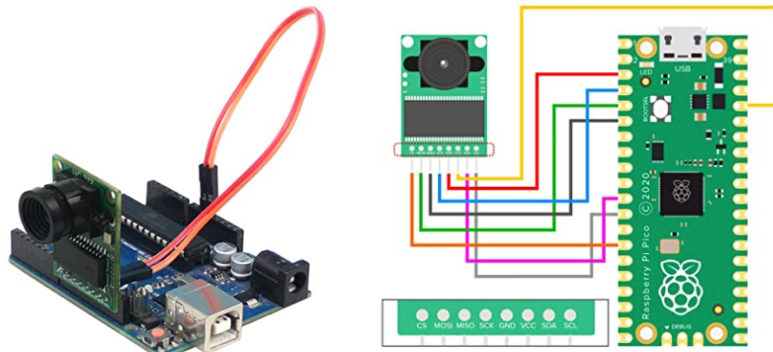

Figure 30 Arducam Mini Module OV2640

5.6.5 Camera Comparison

Table 10 will compare the cameras researched above to allow us to buy the best camera for our project.

Table 10 Camera Comparison

	Port Type	Compatibility	Resolution	Size	Cost
Raspberry Pi Camera v2	CSI	Raspberry Pi	1080p	25 x 23 x 9 mm	\$25
BBTO OV5647 Mini Camera Module	CSI	Raspberry Pi	1080 p	25 x 24 x 9 mm	\$10.39 For 2
Ximimark USB Camera (LY096)	USB	Raspberry Pi	640 x 480 p	3.8 x 1.5 x 3 cm	\$7.79
Arducam Mini Camera Module (OV2640)	Pins	Raspberry Pi and Arduino	-	2 x 1.7 x 1.6 inches	\$25.99

5.7 Food Dispenser

The food dispenser must be able to output the correct amount of food (depending on what pet is currently being fed) in at most 60 seconds. To accomplish this, the dispensing system will consist of a dispensing wheel and a DC motor to power the spinning of the wheel. Since the dispensing wheel will not be operated at high rpm, a low power motor will work perfectly in this case. The motor will be connected to the dispensing wheel, enabling food to be released from its stored container when the wheel is spun. Like the functionality of a gumball machine, each turn of the dispensing wheel will release a small amount of food from the storage container. Due to the controlled nature of the dispensing, the exact amount of food released per wheel rotation can be determined to calculate the time it takes to fully dispense a complete meal (using the wheel rpm as a guideline).

5.8 Microcontroller

In order to prototype and test the internal circuitry of the OptoSmart Pet Feeder, an adequate microcontroller must be selected to accomplish all tasks within the scope of our project. The microcontroller used within the pet feeding device (not including the collar) must be able to interface with the application that will be developed for user interaction with the product. In addition, the selected microcontroller will require the capability to communicate with the DC motors used in the pet feeder and both monitor and control the rpm at which the motor is run. The microcontroller chosen for this project must also be able to interface with the selected webcam (to provide color detection) via native hardware

or some type of adapter that can be obtained/created. Below are the microcontrollers that would best adhere to the scope of the OptoSmart Pet Feeder.

5.8.1 Arduino Uno Rev 3

The Arduino Uno Rev 3 (using ATmega328P onboard microcontroller) shown in Figure 31 will be able to deliver the hardware level actions that are needed for the per feeder, such as activating the DC motor when the correct color data is received and turning on and off the lid closing system. This microcontroller will not be able to handle the image processing from the data that is received directly from the webcam, so an additional microprocessor will be needed to process the color from the image and send the color data to the Arduino. Using an Arduino for this project will allow for use of multiple color detection and imaging libraries that currently exist (due to the open-source nature of Arduino programming). The onboard features of the Arduino Uno Rev 3 include:

- Single 16-bit timer with both compare and capture modes
- Two 8-bit timers with compare mode
- 10-bit Analog to Digital converter
- SPI, I2C, and UART interfaces
- Operating Voltage between 1.8V and 5.5V
- Clock Speeds up to 16 MHz



Figure 31 Arduino Uno Rev 3

5.8.2 MSP 430FR6989

The TI MSP 430FR6989 shown in Figure 32, is another viable option for a microcontroller that will be used to interface with the DC motor, lid closing system, and data from the processed image. Although the MSP430 can be interfaced with a microprocessor (that is able to obtain color data from an image in real time), there is less ease of programming with the MSP430 since there is no way to access multiple existing libraries that can assist with color detection and processing. For approximately the same price as the MSP 430FR6989, the Arduino Uno Rev 3 will most likely allow for the same hardware/software

capability while proving a more user-friendly programming and setup experience. When entering into the prototyping and testing stage of the project design, both the Arduino and TI microcontrollers may be tested within the project to determine which will ultimately be the more efficient option for the final product. The onboard features of the TI MSP430FR6989 include:

- 12-bit Analog to Digital converter
- Five 16-bit timers with compare and capture modes
- SPI, I2C, and UART (with automatic Baud-rate detection) interfaces
- Operating Voltage between 1.8V and 3.6V
- Clock Speeds up to 16 MHz

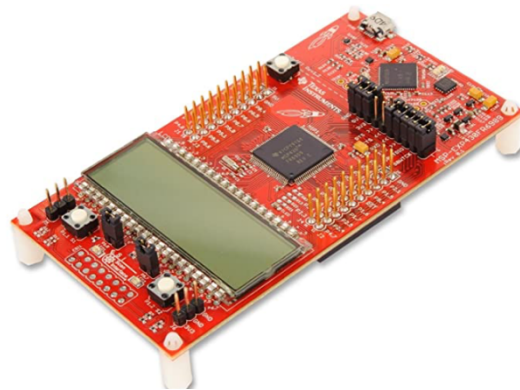

Figure 32 MSP 430FR6989

5.9 Microprocessor

A microprocessor is a computer processor that incorporates the functions of a CPU onto just a few integrated circuits. The microprocessor selection is essential in the developmental process of our project as choice of microprocessor will directly impact any formation of the digital functionality that will further control the I/O peripherals of the physical functionality of the device.

5.9.1 Raspberry Pi 4

A Raspberry Pi 4 is the latest version of the low-cost Raspberry Pi microprocessor that directly plugs into a monitor and uses the general computer peripherals such as keyboard and mouse to use. The Raspberry Pi 4 can achieve any basic computer functionalities such as browsing the internet, playing HD video, creating spreadsheets, word processing, playing games, etc. A Raspberry Pi 4 mostly uses the programming language Python and has its own OS (operating system) called Raspbian in order to operate and use all its capable functionality. The Raspberry Pi 4 has an RAM of 2,4, or 8GB, with an USB 2, and 3 ports, Micro HDMI ports that supports 4K, an USB-C Power Supply, as well as a Gigabit Ethernet port.



Figure 33 Raspberry Pi 4

5.10 Software Tools

The selection of the correct software tools is key to properly create a successfully working system. This section displays all the different software tools that can be utilized to design, develop, or prepare our project.

5.10.1 Python

Python is regarded by most as an interpreted, object-oriented, high-level programming language with dynamic semantics. Often, programmers fall in love with Python because of its increased productivity it provides, as well as there being no compilation step, meaning there are no segmentation faults that occur which allows for the edit-test-debug cycle to be done very efficiently in comparison to other programming languages. Python also has a simpler syntax and formatting compared to other languages and offers an abundance of libraries for anyone to reference in the source code.

5.10.2 C

The C language is a high-level, structure-oriented language that focuses mostly on the implementation of functions to perform most actions within the program. While general purpose languages such as python can be applied to almost any scenario, C is mainly used to develop code to aid in hardware and firmware interactions. C requires a compiler to compile and run the code, meaning that the entirety of a program's code will be converted into binary code and then executed by the machine (machine running the code) every time the program is run. Additionally, the C language does not have many built in functions that can be implemented. Instead, many functions must be developed by the programmer in order to be implemented within the program. The C language also has a strict language syntax that must be learned and followed, unlike python (which is written more similar to a spoken language).

5.10.3 C++

C++ is a language that is a superset of C, and C++ supports polymorphism and inheritance due to it being an object-oriented language. In C++, both data and the developed functions can be linked together through the use of objects, but C only supports procedural programming (data and developed functions are separated). Since C++ is built as a language that provides additional functionality to C, it is usually more simple to program in C++ due to the easier tools that are added into the C++ language. Another contrast between C and C++ is the fact that C is mainly used to implement a top-down approach, while C++ is used to implement a bottom-up approach (meaning smaller modules are first developed before combining them into the main program code). C++ can accomplish most of the tasks that C can do, while including more features and being easier to utilize. Learning how to program in C will translate to being able to program in C++ without much difficulty, and C can still be used for certain applications that require higher speed without the need for the added features of C++.

5.10.4 Atom

Atom is a text editor that provides a specific syntax highlighting for different programming languages. Atom is the software that will be used to write the programming language in order to compile it and run the code on the OS (operating system) or Linux. Atom can edit a variety of different programming languages such as Java, JavaScript, Python, C, C++, and so much more. I especially recommend using atom for any beginner programmers who aren't very familiar with code as the software interface is very vanilla and easy to use and comprehend for all users.

5.10.5 HTML

HTML (Hypertext Markup Language) is the most basic building block of the web that is the standard markup language to create web pages as the language describes the content structure of the written webpages. HTML also displays every written element containing in the webpage such as text and Hypertext. "Hypertext" refers to links that connect web pages to one another, either within a single website or between websites. Links are a fundamental aspect of the Web. By uploading content to the Internet and linking it to pages written by either yourself or other, the programmer has actively contributed to the World Wide Web. HTML can be used to enclose and wrap different segments of the webpage content to make the site appear in a customizable fashion to annotate text, images, and other content for display in a Web browser. There are also tags that are used to encompass the text, image, or hyperlink to display the content to the desired degree on the created webpage to give an identity to specific element.

5.10.6 CSS

CSS (Cascading Style Sheets) is a programming language that allows for the customization of styling for the webpages, making the websites that are written in either HTML or JS

look presentable to the general public. In simpler terms, HTML makes the webpages readable to the user, however, adding a CSS code to a blank HTML webpage allows for the bland webpages to look much better for the user to see. Overall, adding the creative CSS stylings to the blank HTML or JS code allows for webpage to look proper, professional, and overall presentable, whereas a blank HTML or JS page without the CSS stylings is just readable and bland. CSS is a rule-based language that allows for the programmer to define the rules themselves by specifying each group of styles that they prefer to use be to eventually apply themselves to customize each element in the webpage they are creating.

5.10.7 Java

Java is a multi-platform, general-purpose, class-based, network-centric, object-oriented programming language that is fast, secure, and reliable, therefore, is preferred to use by most programmers, including top-level programming organizations to use for their coding projects. The most important aspect of Java is the fact that it is a object-oriented language, which means that all of the programs are made of entities representing concepts or physical structures called objects. Java derives its huge popularity from its platform independence. Java only needs a Java Runtime Environment (JRE) to be installed for the code to compile and run properly. Regardless of whether it is installed in a desktop PC running Windows, Linux, or Unix, or a Macintosh computer running Mac OS. Java's syntax is derived from C and C++ which allows for many programmers who are not familiar to Java but know C or C++ to quickly adapt and use the Java coding language.

5.10.8 JavaScript

JavaScript is a programming scripting language that allows the programmer to implement complex features on the webpage. JavaScript is the code used to write functions to the webpages written in HTML. However, in webpages created in recent times, both the webpages, and the functionality of those webpages can be both written in the programming language JavaScript. Every time a web page does more than just sit there and display static information for you to look at — displaying timely content updates, interactive maps, animated 2D/3D graphics, scrolling video jukeboxes, etc. — you can count on JavaScript to be involved. It is the third layer of the layers involved in standard web technologies, two of which (HTML and CSS) already have previously been discussed.

5.10.8.1 React Native

React Native is an open-source UI software framework that is used to develop web applications that are real, and natively rendering, which the webpage program developers to use as a structural guide to the JavaScript platform capabilities.

5.10.8.2 Reactjs

React is a declarative, efficient, and flexible JavaScript library for building user interfaces. It lets you compose complex UIs from small and isolated pieces of code called

“components”. Reactjs is optimal for creating apps with high functionality and complex calculations. In simpler terms Reactjs is a fancier, clean, and much structurally effect programming language to use for webpage creation by many developers in today’s digital society.

5.10.9 Visual Studio Code

Visual Studio Code is a source-code editor made by Microsoft, that allows for debugging, syntax highlighting, intelligent code completion, snippets, code refactoring, and embedded Git. Visual Studio Code can edit a variety of different programming languages such as Java, JavaScript, Python, C, C++, and so much more. The biggest difference between Visual Studio Code and other text-editor applications are the features that are provided within the software. In Visual Studio Code, programmers may collaborate and code remotely with others who are involved with the project, the pure ability to connect Visual Studio Code to GitHub and being able to push and pull source code from different platforms allow for easy editing use for everybody involved.

5.10.10 GitHub

At a high level, GitHub is a website and cloud-based service that helps developers store and manage their code, as well as track and control changes to their code. There are two connected principles used in GitHub called version controlled and Git. Version control helps developers track and manage changes to a software project’s code. As you can probably figure out, as the software project grows, version control becomes essential. version control lets developers safely work through branching and merging.

With branching, a developer duplicates part of the source code (called the repository). The developer can then safely make changes to that part of the code without affecting the rest of the project. Then, once the developer gets his or her part of the code working properly, he or she can merge that code back into the main source code to make it official.

All these changes are then tracked and can be reverted if need be. Git is a specific open-source version control system. Specifically, Git is a distributed version control system, which means that the entire codebase and history is available on every developer’s computer, which allows for easy branching and merging.

5.10.11 Firebase

Firebase is a development platform known originally for its real-time database that’s still at its core a multi-node, key-value database optimized for synchronizing data, often between user machines or smartphones and centralized storage in the cloud. It’s designed to make life easier for developers by handling much of the pushing and pulling of data. That relieves app developers of the programming burdens associated with managing versions or locations. They can write the new bits to Firebase and the data will be consistent throughout the system.

5.10.12 Ubuntu

Ubuntu is a complete Linux operating system, freely available with both community and professional support. Best suited to compile any code including C, C++, Java, Python, etc. However, whatever code that is being compiled on Ubuntu must be downloaded via sudo to install the specific package needed to compile and run the designated code.

5.10.13 MATLAB

MATLAB is a programming platform designed specifically for engineers and scientists to analyze and design systems and products that transform our world. The heart of MATLAB is the MATLAB language, a matrix-based language allowing the most natural expression of computational mathematics. In MATLAB you can analyze data, develop algorithms, and create models and application for engineers to use to take your ideas from research to production by deploying to enterprise applications and embedded devices to the next level.

5.10.14 SOLIDWORKS

SOLIDWORKS is a solid modeling computer-aided design (CAD) and computer-aided engineering (CAE) computer program used to develop mechatronics systems from beginning to end. At the initial stage, the software is used for planning, visual ideation, modeling, feasibility assessment, prototyping, and project management. The software is then used for design and building of mechanical, electrical, and software elements. Finally, the software can be used for management, including device management, analytics, data automation, and cloud services.

5.10.15 Repl.it

Repl.it is a free online IDE (integrated development environment) that allows users to write their own programs and code in 50+ different coding languages. While traditional IDEs are software programs downloaded to a computer, The great thing about Repl.it is that the software is completely web browser-based and can be accessed from any internet-enabled device such as a phone, tablet, or computer.

5.10.16 Heroku

Heroku is a platform as a service (PaaS) that enables developers to build, run, and operate applications entirely in the cloud. Multinational Companies build, deliver, monitor, and scale apps on Heroku to bypass the structural headaches that come with other service platform applications. The Heroku network runs the customer's apps in virtual containers which execute on a reliable runtime environment. Heroku calls these virtual containers "Dynos" and these Dynos can run code written in Node, Ruby, PHP, Go, Scala, Python, Java, or Clojure, etc service the code via cloud for all to use.

5.10.17 Flutter

Flutter is an open-source mobile SDK developer that can used to build native-looking Android and iOS applications from the same code base. The central idea behind Flutter is

the use of widgets. By combining different widgets that developers can build the entire UI. Each of these widgets defines a structural element (like a button or menu), a stylistic element (a font or color scheme), a layout aspect (like padding), and many others easily by programmers that are highly skilled to the beginners that are new to the platform of creating a mobile application. Flutter also provides developers with reactive-style views. This allows for developers to avoid performance issues deriving from using a compiled programming language to serve as the JavaScript bridge. Flutter also uses Dart, as it compiles the code ahead of time into the native code for multiple platforms. This way, Flutter can easily communicate with the platform without needing a JavaScript bridge that involves a context switch between the JavaScript realm and the native realm of the software development.

5.10.18 SwaggerHub

SwaggerHub is an integrated API development platform that brings together all the core capabilities of the open-source Swagger framework, along with additional advanced capabilities to build, document, manage, and deploy your APIs. SwaggerHub is basically used to allow a consistent and disciplined API development workflow for the back-end code for the webpages to meet with the front-end code to properly function together. With the implementation of the Swaggerhub API collaboration standard, the slowed down cycles when the front-end code communicates with the database and back-end is negated and allows for a smooth workflow for the webpage.

5.10.19 C#

C# is a type-safe, general-purpose, modern and object-oriented programming language. C# enables developers to build many different types of secure and robust applications that compile run in .NET. C# has been derived from the C family of languages and will be immediately noticed and be familiar to C, C++, Java, and JavaScript programmers as the language complements one another very effectively. C# also provides language constructs to the structure of the code development as it directly supports the concepts of making C# a natural language in which to create and use software components in the modern world. C# is widely used by my programmers for developing desktop applications, web applications and web services. However, generally C# is used to create applications that is compatible with Microsoft at a large scale. C# is also somewhat used in game development industry to improve the quality of games for the respective developers.

6.0 Design

This section will describe the part chosen based on the research done in section 5.0. Each part will be decided based on the best fit for our Opto-Smart pet feeder.

Our design will be integrated together to look like the diagram shown in Figure 34.

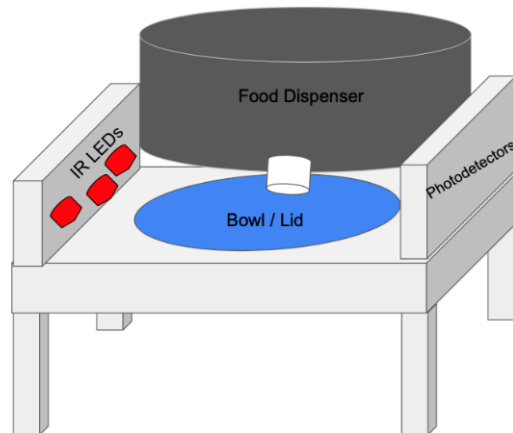

Figure 34 Opto-Smart Pet Bowl Layout

6.1 Bowl and Lid System Design

6.2 LED Design

6.3 Photodiode Design

6.4 PCB Design

6.5 Pet Collar System Design

6.6 Camera System Design

After the completion of the research done in Section 5.6, it was found that the BBTO OV5647 is the best fit for our design. It is cost efficient as it comes in pack of two for only \$10.39. It has a CSI port so it is able to integrate into the Raspberry Pi at the port that was designed for cameras. It is tied as the highest resolution from our comparison. It is compact and will be able to be easily integrated into our design. For these reasons the BBTO OV5647 will be integrated into our OptoSmart pet feeder.

6.7 Food Dispenser Design

The food dispenser design will make use of gravity to allow the food to fall from the storage container into the bowl. A rotating plate (spun by the DC motor) with cutouts will be used

to either hold the food in place (plate is blocking the opening of the storage container) or to allow the food to flow from the container into the bowl (cutout lets the food fall through the plate when the cutout is oriented underneath the storage container). When it is time for the pet to eat and the camera detects the correct color LED from the color of the pet collar the DC motor will spin the plate, allowing the food to fall into the bowl when the cutout is below the funnel where the food can drop through. To test and optimize the speed at which the food is dispensed and the amount of food that is dispensed, we will implement a software timer that is synchronized with the spinning of the motor. The software will measure the rpm of the of motor and run the motor for a set amount of time. We can then measure the amount of food that was dispensed in the time set by the software. Using the obtained approximate number for the volume of food dispensed per second, the amount of time the motor is run for can be permanently adjusted in the software.



Figure 35 Physical Concept of Dispensing Wheel

6.8 Microcontroller Design

The microcontroller that was selected to be used within our project after analyzing the information from the research section was the Arduino uno. Since our team will make use of a microprocessor, the Arduino architecture will be able to interface more simply with a microprocessor in order to transmit crucial image data. Additionally, Python can be used to program code for the Arduino as well as the Raspberry Pi 4, which makes synergy between the two devices much more seamless.

6.9 Microprocessor Design

After completing the research portion of the potential microprocessors to use for our project, it was a no brainer to go with the Raspberry Pi 4. The Raspberry Pi 4 microprocessor has all the necessary capabilities and functionality to have our device reach

its fullest potential. With the Raspberry Pi 4 microprocessor basically being a microcomputer, the Raspberry Pi 4 can and will for our case replace a traditional desktop within the system as the microprocessor takes in all inputs related to a traditional desktop such as a power supply, HDMI, keyboard and mouse, with proper WIFI, and ethernet control making the possibilities of the Raspberry Pi 4 practically endless. Specifically for our project, the Raspberry Pi 4 will act as the brains of our device operation allowing the system to dissect logic with the implemented Python code, especially when we plug in a compatible camera input into the Raspberry Pi 4 and allow for the camera to detect the LED light attached to the collar of the pet to further determine whether or not the color of the LED light is correct (true), and ultimately open the lid properly for the animal to eat the food. The Raspberry Pi 4 can also potentially display the logic being handled internally with digital machine language to a display connected to the HDMI for the user to see externally while in work.

The CanaKit shown in Figure 36 was purchased on Amazon for \$119.99. It includes the Raspberry Pi 4 4GB model B with 1.5 GHz 64-bit quad-core CPU and 4 GHZ of Ram. It comes with a 32GB Samsung EVO+ micro SD Card. It also comes with a case that has a fan integrated in order to help regulate the temperature as well as help keep the system functioning efficiently. It comes with the 3.5A USB-C power supply as well as heat sinks, a 6 foot micro HDMI to HDMI cable, and a power switch. This kit comes with a wide range of accessories we need in addition to the Raspberry Pi 4.



Figure 36 CanaKit Raspberry Pi 4 4GB Starter PRO Kit

6.10 Software Design

After completing the research portion of the potential software programs to use for our project, we collectively determined to use Python as the coding language for our microprocessor as the Raspberry Pi 4 heavily supports the Python programming language to operate any sort of customized functionality. Python offers a much simpler syntax in comparison to other older programming languages such as C, and C++, where in languages such as C, and C++, the formatting syntax can be very tricky and confusing as for most users having to iteratively define every method, and function used while having its structure intact as well. Debugging can also be very tough to handle in languages such as C, and C++ as the error messages are 9 out of 10 times unclear to what they meant with segmentation fault occurring every time you don't allocate space for memory, However, in Python, debugging can be done as easy as with a push of a button with clear error messages, single definition of variables, and never running out of memory with automatic dynamic allocation. Python also offers an abundance of libraries for anyone to reference in the source code which allows for a greater capability to accomplish any difficult logic/algorithms that may be even more difficult to program in other object-oriented programming languages such as Java. This Python code will generally be written, edited, compiled, debugged, and ran in Visual Studio Code which is in my opinion one of the best code editor available for Python with its redefined and optimized building structure for editing, and a state-of-the-art debugging system especially molded for the modern web and cloud applications. Also, the program being free to all users is a plus. The highlighting capability that can be optionally installed into the program externally is very useful with colorful hints for organization, and error hint messages that is provided before even compiling the code is a nice add-on. Other code editors such as Atom, and Repl.it, can get the job done, however, the efficiency of coding on Visual Studio Code is unmatched. Even being able share the code with others is difficult with Atom, and compiling multiple files is difficult on Repl.it, but Visual Studio Code can and will accomplish the best of both worlds. Visual Studio Code also has a compiler terminal built into the program, having access to it while editing on the same software. With Visual Studio Code having the ability to directly connect with GitHub allows for the perfect Segway of describing the correct implementation and use of the software GitHub into our group project. The organizational standard and structural definition that GitHub provides allows for collaborative programming work to be done by the author and easily have him/her post online to the group GitHub account and allow secure access to every member of the group who might needs to push or pull the code to their project's code from online to their machine and vice versa is very useful in the modern era of collaborative programming. Like mentioned previously not only is the access to the collaborative work efficient, however, it adds organization and structure to the created programming code which is always effective and professional to have especially better than having all the code written to be jumbled up on some file stored locally on your storage drive somewhere.

7.0 Testing Design

In order to test our design we will compare the functionality of our working design with the objectives and project specifications discussed in Section 2.0.

8.0 Design Constraints and Standards

This section discusses the standards relating to the Opto-Smart pet feeder, as well as the realistic design constraints of the project. These constraints may be financial, ethical, technological, or legal constraints. These must be noted and observed accordingly for this product to be a success.

This section contains:

- A list of design constraints relating to the Opto-Smart pet feeder.
- Standards that apply to the product.

8.1 Standards and other Safety Concerns

In this section, various ethical and safety standards are addressed and examined. Also, there is a discussion pertaining to each standard and how it relates to our design. This section outlines the ethics of working with live animals (cats and dogs), and the safety protocols of working with soldering equipment.

8.1.1 Standards for Working with and around animals

The *Animal Welfare Act*, 7 U.S.C. § 2131 et seq. states the minimum requirements for the treatment and care of animals to be used in research applications. This Opto-Smart pet feeder will not require the use of animals during the research and construction of the device. To test the finished design of the pet feeder with either dogs or cats, our group will have to abide by the standards proposed in the before mentioned *Animal Welfare Act*. Any animals that may be used during the process of testing the designed pet feeder will be treated humanely and given any human care and treatment needed to keep the dog/cat in a healthy state. In order to test the Opto-Smart pet feeder without having to deal with any restrictions on working with real animals, artificial (stuffed) animals may be used to test the functionality of the LEDs on the collar. Most of the engineering requirement specifications will be able to be measured with the use of the artificial animals.

8.1.2 Soldering Standards

The National Aeronautics and Space Administration (NASA) published a national technical standard titled “Soldered Electrical Connections” that describes NASA’s process and requirements for soldered electrical connections. In this document, they discuss proper soldering techniques along with many useful diagrams which this document will utilize here to show how exactly solder should be applied to the PCB. This documentation goes into elaborate detail about reliable solder connections, tool control, correct materials, proper processes, and careful workmanship. Another key feature that is used in this process to mitigate stress relief is the use of a plated-through hole during the mounting configuration.

Another step to ensure professional soldering is the use of the correct soldering equipment. This NASA document alludes to the mandatory use of: (Not in any specific order) Mechanical strippers, thermal strippers' chemical strippers holding devices, bending tools, conductor cutting tools, anti-wicking tools, cleaning tools, and thermal shunts. The documentation reveals that proper solder and flux are paramount for correct solder technique, they recommend flux covered solder of either composition SN60 or SN63 that contain flux type R or RMA for correct solder work.

Preparation of the surface that is about to be soldered is vital to a good soldering job. NASA created a table to show the safe and effective chemicals for removing oil and debris. NOTE: These cleaners and solvents can potentially be hazardous and/or volatile. Before using any of the products listed below in Table 11, please consult with manufacturer guidelines and any safety data sheets present.

Table 11 Solvents and Cleaners

Solvent	Specification
Ethyl Alcohol	O-E-760, Types III, IV, or V
Isopropyl Alcohol	TT-I-735
Methyl Alcohol (see 3.12-2)	O-M-232, Grade A
Butyl Alcohol, Secondary (see 3.12-2)	ASTM-D1007
Cleaners	Specification/Note
Water	1 megohm-cm, minimum resistivity (see 6.13.3)
Detergent cleaners and saponifiers	(See 6.13.4)

Once the PCB has been cleaned properly, hand soldering may now commence. Molten solder must flow around the conductor and the termination areas, though one must be careful not to deposit too much solder or else the excess may flow to other terminals and cause a short. In this case de soldering must occur, and the work area must be cleaned before resoldering can take place. Another thing to watch out for is not applying enough solder, this can lead to poor contact and can affect the quality of the device.

8.1.3 Lead Soldering Safety

Soldering with lead can be extremely dangerous. Lead poisoning can have symptoms that can be noticed immediately, with long term affects that can last a lifetime. Harvard campus services Environmental health and safety states that the WHO (World Health Organization) has classified lead as a class 2A carcinogen, which means “it is probably carcinogenic to humans”. Normal skin contact is harmless, the danger with lead soldering is that when melted with an electric soldering iron at high temperatures 300 – 500 degrees Celsius can cause the lead to vaporize into the air and can be inhaled. Symptoms can include headache, abdominal pain, joint and muscle pain, memory loss, mood disorders, cancer etc. safety precautions must be taken to ensure proper safety working with proper ventilation such as a fan or a fume hood can remove toxic fumes from the local atmosphere. The next problem

with solder is heat. A freshly soldered joint can be extremely hot! Avoid skin contact with freshly soldered joints and hot soldering irons, and wear gloves whenever possible. After work is completed ensure, the workspace is free of lead dust (this is just as or more dangerous than the fumes) by washing surfaces with soapy water and clean towels. Also, do not use an air gun or a broom to clean lead solder dust, this can stir up the lead dust causing it to be inhaled.

8.1.4 Electrical Power Safety Standards (NFPA 1)

Section 11.1 of *NFPA 1* documents the basic electrical safety requirements when dealing with power adapters and extension cords. Any power strips used to deliver power to the OptoSmart Pet Feeder must be rated for the correct current that must be fed into the electronics of the pet feeder. Power extension cords must not be plugged into separate external power strips (daisy chaining should be prohibited). In order to safely deliver power to the internal electronics (microcontroller and microprocessor) the power delivered to the circuit will be directly from a power outlet with the use of an adapter that delivers a constant voltage to both the microcontroller and microprocessor inside the housing of the pet feeder.

8.1.5 PCB Standards (IPC -2221A)

According to the Rigid Printed Board Committee (D-30) of IPC there are generic standards on printed board design (PCB). This covers the component mounting, design and interconnection requirements for PCB general designs including rigid, flex, PCMCIA, MCM-L, and HDIS []. PCB's must be of high quality for the product to have a long lifetime without any components needing repairs or replacements. IPC-2221A states the component the component parameters as follows

Table 12 PCB Design Tolerances

Feature	Clearance
Component Leads	0.13 mm (up to a voltage of 50V)
Uncoated conducting areas (washers or similar mechanical hardware)	0.75 mm
Test Probe sites	80% of component height (0.6mm minimum and 5mm maximum)
Mounting Hardware	Should not protrude more than 6.4 mm below PCB surface
PTH (Plated through hole) relief in the heat sink	2.5 mm larger than the hole (includes electrical clearance and misregistration tolerance)

Data taken from <https://www.protoexpress.com/blog/ipc-2221-circuit-board-design/>



Figure 37 Example of clearance between traces on PCB

(Courtesy of <https://www.protoexpress.com/blog/pcb-2221-circuit-board-design/>)

Trace thickness must also be considered. Depending on the amount of current running through the trace will determine its thickness, wires can also be used as traces in some instances. The greater the amount of current flowing through the trace, the higher the temperature the trace will have due to its internal resistance. A larger trace will be able to withstand greater currents.

Insulation is also required in PCB design. This prevents short circuits and can prevent accidental contact with people, the environment, and the components themselves. This can be managed by using wires that already have insulation and by covering PCBs wherever possible with plastic or rubber. Grounding the components also helps with insulation

8.1.6 C Language Programming Standards

The current standard for the C programming language is *ISO/IEC 9899:2011*, which was originally established in 2011. This standard indicates the way C programs should be represented, the syntax of the C language, the rules for interpreting any C program, how input data is processed/output data is produced by a C program, and any restrictions put into place with the current implementation of C. Any use of the C programming language to develop software for the Opto-Smart Pet Feeder must conform to the C standard above in order to be able to be portable across a variety of different devices that may utilize the created software.

8.2 Realistic Design Constraints

The Opto-Smart Pet Feeder has realistic design restraints as listed below in sections 8.2.1 through 8.2.10. These various restraints are being considered during the design process to create an optimal product that is price effective, ethical, and safe. Each constraint has been carefully considered in regard to its realism had how it will be applied to the design.

8.2.1 Economic Constraints

Historically, pet bowls are inexpensive. Many pet owners use normal bowls, which can be as inexpensive as a few dollars. With a target cost of around \$500, our elevated design will be one of the more expensive dog feeders on the market. With high-tech features comes a raised expensive. Our target audience will be owners who are on the go and need the luxury of a pet bowl that can feed their pets when they are not home.

8.2.2 Time Constraints

The extent of the design of the Opto-Smart Pet Feeder will be determined by not only the economic constraints highlighted above, but also the time that is available to research, design, and test the product. These developed time constraints will aid in the project outline by setting a template for when each section of our product creation/design should be completed. The research and part selection for the Opto-Smart Pet Feeder will be set to be complete by December 3, 2021, after which a realization of the proposed design should be able to be produced and tested. At the end of the 2022 Spring semester (May 2022), the fully complete Opto-Smart Pet Feeder will be presented. By placing a time constraint of December 3, 2021, on the research, part selection, and PCB design, there will be enough time to properly analyze and correct any issues that may arise in the initial design process. If an originally proposed component of the Opto-Smart Pet Feeder will not be able to create within the given time frame, alternate design methods will need to be considered to meet the provided deadlines.

8.2.3 Environmental Constraints

There are countless different automated pet feeders on the market today and they can be picked up just about anywhere. the Opto-Smart Pet feeder differs from many of these designs due to its designed being sourced from off the shelf components. These components include all the mechanical, electrical, and optical elements of the design. Another positive aspect of this design is all of these components can be bought cheaply and are high enough quality that this device can last the entire lifetime of the pet without failure. This reduces environmental waste and satisfies the environmental constraint

8.2.4 Ethical Constraints

Care must be taken when designing any product that animals interact with. The amount of care should be amplified when designing a device with motors, gears, and electronics. Safety is the number one priority of this project, from the pets that will be using this project, the end users, and the design team members. All gears and motors must be shielded so that they do not come into contact with the pet or the pet food. All electrical contact points must be covered insulated and properly grounded to prevent an electric shock to the user or the pet. The lid to the device must open to allow the pet to eat and must stay open while the pet is eating to avoid any injury to the pet. All optical components of the device must also

not interfere with the user or the pet's vision and must be shielded wherever necessary. The collar tag of the device must also always function to allow the pet to be able to eat.

It is also noted that the Opto-Smart Pet Feeder does not infringe on any existing patents, and any existing designs will not be used without the express permission of the patent holder with proper credit given.

8.2.5 Sustainability Constraints

Most pet feeding bowls or devices that are available today are constructed to be able to last long periods of time without deterioration (normally on the scale of years). The Opto-Smart Pet Feeder will consist of multiple parts that are actively in motion, such as the covering lid as well as the motor that drives the dispensing system. Due to the nature of the restricted amount of time provided for developing a working version of the Opto-Smart Pet Feeder, there will most likely not be adequate time available to test the longevity of the completed device. However, the quality of motor and choice of materials for the device will be selected in order to positively impact the lifespan of the designed pet feeder. The longer the pet feeder is able to continue working without any electrical/mechanical failures, the less waste will be produced by any repairs done to the device and the user will not have any unexpected expenses in regard to a replacement unit.

8.2.6 Social Constraints

The target audience for our product are pet owners who lead busy lives and need assistance in ensuring their pets are properly fed. With the recent COVID-19 outbreak, there has been a push to work from home. This has the potential to decrease the number of people in our target audience as many people who spent long hours in the office now may be working beside their pet. As life begins to return to normal, these owners that are currently working from home may need to return to the office and will appreciate knowing their pets are well taken care of. All pet owners will need to leave their pets home alone at some point and could use the peace of mind knowing they are fed. This product can be useful to all types of owners regardless of their employment status as it can prevent pets from eating out of their siblings' bowl and has a lid which helps keep the food fresh.

8.2.7 Political Constraints

After examining the project carefully, it was determined that any potential political constraint was not relevant towards the Opto-Smart Pet Feeder

8.2.8 Health and Safety Constraints

Working with animals comes with a responsibility to protect their health and safety. Since the Opto-Smart Pet Feeder will directly touch their food, care will be taken to ensure the food cannot be contaminated. Bisphenol A (BPA) free bowls and equipment will be used to prevent sickness. No sharp object will be placed in the bowls or the mechanism that will dispense the food to ensure safety. Instructions for use of the product will be created for

the user to ensure they are properly using the system. This will help eliminate user errors that can lead to injury. There will also be safety features implemented within our design to make sure no animals get hurt while eating out of our bowl. The IR LEDs and photodiodes will be used to ensure that the lid does not close until the pet exits the area of the food bowl. This will make sure that the lid does not close on them. The effects of IR LEDs on the pets' eyes will be researched to ensure that no harm will come to the pets that stand in the lights path. If our product does not function properly the pets may not be fed, which can lead to starvation. Thorough testing will be conducted to ensure that our product functions properly.

8.2.9 Manufacturability Constraints

When creating the Opto-Smart Pet feeder, one must consider material availability, or the manufacturing constraint. At the time of writing this paper, COVID-19 is still causing supply chain issues around the world, this is causing severe impacts to nearly every business sector and has made ordering material much more difficult and expensive. When selecting certain components, the team must work together to ensure that that piece of equipment can arrive at a reasonable time and at a reasonable price that still fits into the budget.

Prototyping this design will also be a challenge for this device, this will be made slightly easier using the Electrical and Photonic Engineering labs at the University of Central Florida. Unexpected costs such as equipment failure may also arise and may put strain on an already tight budget, all these things must be considered while following to the manufacturability constraint.

8.2.10 Testing/Presentation Constraints

The main user of our product are pets. Preferably we would like to present using live animals to show real life use of the Opto-Smart Pet Feeder. The University of Central Florida has a No-Pet policy. This means we will not be able to bring in our own pets for the live demonstration. Instead, stuffed animals may be used to show the functionality of the Opto-Smart Pet Feeder. Live pets will test out the product at home during the building phase and videos and photographs will be taken for proof of concept.

9.0 Conclusion

By combining optics and photonics with electrical and computer science, the Opto-Smart pet Feeder was born. The Opto-Smart Pet Feeder will be able to bring peace of mind to busy pet owners. By allowing owners to select feeding times, and the appropriate amount of food, pets will always be properly fed. This user-friendly app brings customized feeding features to the pet owner. By having a lid that will open when the corresponding pet enters the vicinity, pets will not be able to steal the food of their siblings. This is very useful for overweight pets that eat too many servings of food, and the other pet that's food is being eaten. It can also be used for pets that have to take medication as the lid will ensure only the correct pet is eating out the bowl. The lid will not close until the integrated photodiodes do not detect the IR LEDs because of the pet standing in the way. Once the photodiodes

detect the IR LEDs a countdown will start and if the pet does not interrupt the signal the lid will close. This ensures no other pets can eat out of their bowl.

10.0 Appendix

10.1 Schedule

Table 13 Project Milestones

Senior Design I	Who is completing the task	Start Date	Due Date	Status
Understanding the scope of the project	Group 9	8/26/2021	9/3/2021	Completed
Role assignments	Group 9	9/3/2021	9/3/2021	Completed
Identify parts	Group 9	9/10/2021	12/3/2021	In Progress
Project report				
Initial Document	Group 9	9/10/2021	9/17/2021	Completed
Updated initial document	Group 9	9/17/2021	10/1/2021	Completed
First draft	Group 9	8/1/2021	11/5/2021	Completed
Final draft	Group 9	11/5/2021	11/19/2021	In Progress
Final document	Group 9	11/19/2021	12/7/2021	In Progress
Research, documentation, and design				
Microcontroller	Ricky	9/17/2021	12/3/2021	Researching
Lens design	Tyler	9/17/2021	12/3/2021	Researching
Circuitry	Jacob	9/17/2021	12/3/2021	Researching
PCB	Jacob	9/17/2021	12/3/2021	Researching
Schematics	Jacob/Ricky	9/17/2021	12/3/2021	Researching
LEDs	Cassidy	9/17/2021	12/3/2021	Researching
Cameras	Tyler	9/17/2021	12/3/2021	Researching
Motors	Tyler	9/17/2021	12/3/2021	Researching

Dispensers	Jacob	9/17/2021	12/3/2021	Researching
Housing for electronics	Jacob	9/17/2021	12/3/2021	Researching
Photodiode	Cassidy	9/17/2021	12/3/2021	Researching
Gear Mechanisms	Jacob/Tyler	9/17/2021	12/3/2021	Researching
Code used for project	Ricky	9/17/2021	12/3/2021	Researching
Order and test parts	Group 9			
Senior Design II				
Build prototype		TBD	TBD	
Testing and redesign		TBD	TBD	
Finalize prototype		TBD	TBD	
Practice presentation		TBD	TBD	
Final Report		TBD	TBD	
Final Presentation		TBD	TBD	

10.2 Acronyms

Table 14 Acronym List

BPA	Bisphenol A
DC	Direct Current
IC	Integrated Circuit
IR	Infrared
LED	Light Emitting Diode
MOSFET	Metal-Oxide-Semiconductor Field-Effect Transistors
PCB	Printed Circuit Board
PTH	Plated through hole
NASA	National Aeronautics and Space Administration
RAM	Random Access Memory
RGB	Red Green Blue
TBD	To Be Determined

10.3 Work Cited

(7 USC, 2131-2156: *Animal Welfare Act as amended.* ; Ada; *Advantages of fresnel lenses: Edmund Optics.* ; *Applying IPC-2221 standards in circuit board design*; DigiKey; DigiKey; Electronics; Institute.; Instruments; *Laboratory safety guideline - ehs.harvard.edu.* ; *Lead soldering safety.* ; LEDs.; NASA; Newark; Solutions; Tech.; *What is a market requirements document (MRD)?*)

7 USC, 2131-2156: *Animal Welfare Act as amended.* . Retrieved 11/5/2021 from <https://ori.hhs.gov/content/Chapter-4-The-Welfare-of-Laboratory-Animals-7-usc-2131-2156-animal-welfare-act-amended>.

Ada, L. *Ladyada's learn Arduino - lesson #0.* . Retrieved 11/5/2021 from <https://learn.adafruit.com/ladyadas-learn-arduino-lesson-number-0/power-jack-and-supply>.

Advantages of fresnel lenses: Edmund Optics. . Edmund Optics Worldwide. . Retrieved 11/4/2021 from <https://www.edmundoptics.com/knowledge-center/application-notes/optics/advantages-of-fresnel-lenses/>.

Applying IPC-2221 standards in circuit board design. Sierra Circuits. . <https://www.protoexpress.com/blog/ipc-2221-circuit-board-design/>.

DigiKey. *MV50154.* <https://www.digikey.com/en/products/detail/everlight-electronics-co-ltd/MV50154/2675588>.

DigiKey. *NTE30048* *NTE* *Electronics, Inc* https://www.digikey.com/en/products/detail/nte-electronics-inc/NTE30048/11656062?utm_adgroup=General&utm_source=google&utm_medium=cpc&utm_campaign=Shopping_DK%2BSupplier_NTE+Electronics&utm_term=&utm_content=General&gclid=Cj0KCQjwiNSLBhCPARIsAKNS4_fu6Bn04j4uTPxfgXqo9Eu2no6DbLC-qBbbrbXBZ0HX9USdLgt8Sr0aAqzuEALw_wcB.

Electronics, M. M. *BPV23FL* *vishay* *semiconductors.:* https://www.mouser.com/ProductDetail/Vishay-Semiconductors/BPW82?qs=0%2Fjqivxn91ccMymVfeKLCiQ%3D%3D&mgh=1&gclid=CjwKCAjwoP6LBhBIEiwAvCcthP8FVGG7vE6qljzfpbmBpahgiL9pS4eiA-TOf1cBbYE-fLa6JnMoRoCBruQAvD_BwE.

Institute., L. I. *7 U.S. Code § 2131 - Congressional Statement of Policy.* <https://www.law.cornell.edu/uscode/text/7/2131>.

Instruments, T. *MSP430FR6989 data sheet, product information and support* <https://www.ti.com/product/MSP430FR6989#features>.

Laboratory safety guideline - ehs.harvard.edu. . https://www.ehs.harvard.edu/sites/default/files/lab_safety_guideline_mercury.pdf.

Lead soldering safety. . <https://blink.ucsd.edu/safety/occupational/hazard-control/lead-soldering.html>.

LEDs., S. B. *RL5-R8030.* . https://www.superbrightleds.com/moreinfo/through-hole/5mm-red-led-30-degree-viewing-angle-8000-mcd/281/1208/?utm_campaign=Child%2B%2BOrganic%2BShopping&utm_source=More%2BLEd%2BLighting%2B%3E%2BThrough%2BHole&utm_medium=RL5-R8030.

- NASA. *Soldered electrical connections* - <https://nepp.nasa.gov/docuploads/06AA01BA-FC7E-4094-AE829CE371A7B05D/NASA-STD-8739.3.pdf>.
- Newark. *S2386-5K - photo diode, 960NM, 5PA, to-5-2*. .
https://www.newark.com/hamamatsu/s2386-5k/photo-diode-960nm-5pa-to-5-2/dp/21AH4487?gclid=CjwKCAjwoP6LBhBIEiwAvCcthPKbQgHwom7tX8J7ExXF_v1ZHVgiAlOW5JJEfBweDPOTOhEmLZdORhoCbVMQAvD_BwE&mckv=sodAuYEFh_dc%7Cpcrid%7C509808252197%7Cplid%7C%7Ckword%7C%7Cmatch%7C%7Cslid%7C%7Cproduct%7C21AH4487%7Cpgrid%7C100464450946%7Cptaid%7Cpla-904062949885%7C&CMP=KNC-GUSA-GEN-Shopping-NewStructure-Optoelectronics-Displays.
- Solutions, C. P. *Applying IPC standards to PCB layout design*. .
<https://resources.pcb.cadence.com/blog/2021-applying-ipc-standards-to-pcb-layout-design#:~:text=For%20PCB%20designers%2C%20the%20must,be%20implemented%20on%20a%20PCB>.
- Tech., R. (11/4/2021). *Real-time color detection using webcam and Arduino*.
<https://www.robotique.tech/robotics/real-time-color-detection-using-webcam-and-arduino/>.
- What is a market requirements document (MRD)?* . Retrieved 2021, September 28 from
<https://www.aha.io/roadmapping/guide/requirements-management/what-is-a-market-requirements-document>.