

Initial Project Document

# Portable Fluorescence Sensor for Lyme Disease Antibody Detection

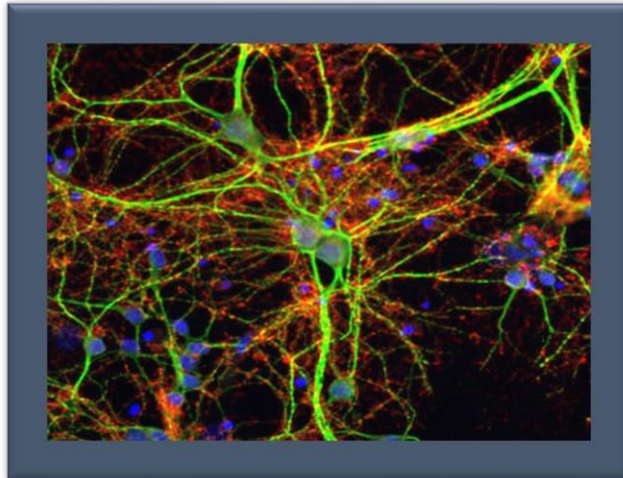

## University of Central Florida

Department of Electrical Engineering and Computer Science

Department of Photonic Sciences and Optical Engineering

Dr. Richie & Dr. Kar

Sponsors:

Everix

Senior Design 1

## Group 6

Cristian Pearson - Photonics & Optics Engineering

Christian Spurgeon – Photonics & Optics Engineering

Gean Morales – Electrical Engineering

Aaron Jevitt – Computer Engineering

# Table of Contents

Table of Contents .....	ii
Table of Figures .....	iv
1 Executive Summary.....	1
2 Project Description .....	2
2.1 Motivation and Goals.....	2
2.1.1 Core.....	2
2.1.2 Advanced.....	2
2.1.3 Stretch.....	2
2.1 Project Objectives .....	2
2.2 Requirement Specifications .....	3
2.2.1 Requirements for Hardware: .....	3
2.2.2 Requirements for Software: .....	3
2.2.3 Requirements for Optical System.....	4
2.3 House of Quality .....	5
3 Research Related to Project Definition.....	7
3.1 Existing Similar Projects and Products .....	8
3.2 Strategic Components and Part Selections.....	9
3.2.1 Photodetectors.....	9
3.2.2 LED for Excitation .....	15
3.2.3 Led Driver.....	16
3.2.4 Indicator LEDs .....	16
3.2.5 Battery.....	16
3.2.6 MCU .....	18
3.2.7 Display.....	18
3.2.8 Analog to Digital Converter .....	19
3.2.9 Battery Protection and Charging .....	20
3.2.10 Power Regulator .....	20
3.2.11 Optical Filter .....	22
3.2.12 Considerations for Prototype Lens Holder.....	30
3.2.13 Enclosure.....	32
3.3 Parts Selection Summary .....	33
3.3.1 Electrical Components .....	33
3.3.2 Optical Components Table.....	35

4	Related Standards and Realistic Design Constraints .....	36
4.1	Standards .....	36
4.1.1	<i>Fluorescence Spectroscopy Standards</i> .....	36
4.1.2	<i>Safety Standards</i> .....	37
4.2	Realistic Design Constraints .....	39
4.2.1	<i>Economic and Time Constraints</i> .....	39
4.2.2	<i>Manufacturability and Sustainability Constraints</i> .....	40
4.2.3	<i>Ethical, Health and Safety Constraints</i> .....	41
4.2.4	<i>Ethical, Political, and Social Constraints</i> .....	42
4.2.5	<i>General Constraints</i> .....	43
5	Project Hardware and Software Design Details.....	44
5.1	Initial Design Architecture and Related Diagrams .....	44
5.1.1	<i>Integrated System Diagram</i> .....	44
5.1.2	<i>Data Path Diagram</i> .....	44
5.1.3	<i>Optical System Diagram</i> .....	45
5.1.4	<i>Electrical Diagram</i> .....	48
5.1.5	<i>Software Flow Diagram</i> .....	48
5.2	Electrical Subsystem .....	49
5.2.1	<i>Electrical Schematic Diagram</i> .....	49
5.2.2	<i>Electrical Subsystems</i> .....	49
5.2.3	<i>BOM</i> .....	51
5.2.4	<i>PCB Layout</i> .....	52
5.3	Optical Subsystem.....	52
5.3.1	<i>Fluorescence Detection Optical Sub System</i> .....	53
5.3.2	<i>Fluorescence Detection Optical Sub System Paraxial Ray Trace:</i> .....	59
5.3.3	<i>Overall Case 1 Optical Design</i> .....	67
5.3.4	<i>Case 2: Fluorescence Detection Optical Subsystem with Curved Filter</i> .....	70
5.4	Software Design .....	74
5.4.1	<i>Software Implementation</i> .....	74
5.4.2	<i>User Interface</i> .....	77
5.4.3	<i>UML Class Diagram</i> .....	83
5.5	Summary of Design .....	85
6	Project Prototype Construction and Coding .....	85
6.1	Integrated Schematics .....	85

6.2	PCB Vendor and Assembly .....	86
6.3	Prototype Construction.....	86
6.3.1	<i>Prototype Lens Holder</i> .....	87
6.4	Final Coding Plan .....	87
7	Project Prototype Testing Plan .....	87
7.1	Electrical System Testing.....	88
7.1.1	<i>PCB Testing</i> .....	88
7.1.2	<i>Photodiode Calibration Testing</i> .....	98
7.2	Software Testing .....	98
7.2.1	<i>Local HMI Testing</i> .....	98
7.2.2	<i>Web Client Testing</i> .....	100
7.3	Optical Prototype Testing .....	103
7.3.1	<i>Methods of Testing</i> .....	103
8	Operation Manual.....	115
8.1	Basic Information .....	115
8.2	Basic Use with web GUI .....	115
8.3	Basic Use without Web GUI .....	116
8.4	Charging .....	116
8.5	Calibration.....	116
8.6	Troubleshooting.....	117
9	Administrative Content.....	118
9.1	Milestone Discussion .....	118
9.2	Budget and Finance Discussion.....	120
10	Citations .....	121

## ***Table of Figures***

Figure 1	House of Quality.....	5
Figure 2	Recommended circuit for Photo Detector Diode .....	15
Figure 3	DC-DC Regulator vs Linear Regulator.....	20
Figure 4	Linear regulator efficiency calculation .....	20
Figure 5	Switching regulator efficiency calculation .....	21
Figure 6	Switching regulator set up .....	21
Figure 8	Nano-meter bandpass optical filter, Edmund optics .....	22
Figure 9	PDF drawing of 50 nm bandpass filter from Edmund optics .....	23

Figure 10 500 nm longpass filter Everix.....	23
Figure 11 PDF drawing of 500 nm longpass filter from Everix.....	24
Figure 12 specification of Thorlabs 465E LED.....	25
Figure 13 theoretical intensity distribution of Thorlabs 465E LED.....	26
Figure 14 radial intensity distribution of Thorlabs 465E LED.....	26
Figure 15 Distance between LED and sample based on angle.....	26
Figure 16 Normalized intensity of Thorlabs 405E LED.....	27
Figure 17 LED 405L normalized intensity distribution.....	28
Figure 18 Angular radiance equation.....	28
Figure 19 LED angular intensity patterns.....	29
Figure 20 Radiance equation for dome surface pattern of LEDs.....	29
Figure 21 Tough Resin Specs Chart.....	33
Figure 22 Initial Integrated System Diagram.....	44
Figure 23 Initial Data Path Diagram with Legend.....	44
Figure 24 Initial Optical Diagram.....	45
Figure 25 Previous Excitation Optical Sub System Paraxial Ray Trace.....	46
Figure 26 Initial Excitation Optical Subsystem Paraxial Ray Trace Matrices.....	47
Figure 27 Initial Electrical Diagram.....	48
Figure 28 Initial Software Flow Diagram.....	48
Figure 31 Final Project Schematic.....	49
Figure 29 BOM (bill of material).....	51
Figure 32 Printed Circuit Board design (PCB).....	52
Figure 33 Fluorescence optical subsystem overall design using lens as in case 1 of our design.....	52
Figure 34 Diagram of light cut-off case for LED reflected light.....	55
Figure 35 Diagram of the rotation of the LED and light emission reflected off the sample.....	56
Figure 36 Minimum rotation angle of LED plot of equation 13.....	57
Figure 37 Diagram of the separation between LED, collimating lens, and the sample container.....	58
Figure 38 Diagram showing the plot of equation 16 shifted down by 3 mm.....	59
Figure 39 Fluorescence Detection Optical Sub System Paraxial Ray Trace.....	60
Figure 40 Fluorescence Detection Subsystem Paraxial Ray Trace Matrices.....	60
Figure 41 Minimum rotation angle & distance between LED and plano-convex lens vs. LED to sample container distance.....	65
Figure 42 Positioning of LED and plano-convex lens orientation.....	66
Figure 43 Overall Case 1 Optical Design Layout.....	67
Figure 44 Geometric representation of optical design width.....	68
Figure 45 Geometric diagram of length of optical design.....	68
Figure 46 Case 1 optical design Zemax optimization.....	69
Figure 47 New Optical Design.....	70
Figure 48 Curved Filter.....	71
Figure 49 Diagram depicting wavelength and angular shift due to angle of incidence.....	71
Figure 50 Equation for blue shift.....	72
Figure 51 Calculations and depiction of angles of incidence of light from an LED source.....	72
Figure 52 Case 2 optical design schematic.....	74

Figure 53 Block Diagram of Microcontroller and Web Client.....	75
Figure 54 On Device Startup Screen Client Mode.....	78
Figure 55 On Device Startup Screen in Wi-Fi Broadcast mode.....	78
Figure 56 On Device Profile Change Screen.....	78
Figure 57 Scan in Progress .....	79
Figure 58 On Device In remote control Screen.....	79
Figure 59: Example Home Screen for Web Interface.....	80
Figure 60 Example of Menu Screen .....	80
Figure 61 Example of Configuration Screen.....	81
Figure 62 History Screen Example .....	82
Figure 63 System Configuration Example .....	82
Figure 64 Software UML Diagram.....	83
Figure 65 Optical Schematic Diagram .....	85
Figure 66 Electrical Schematic Diagram.....	86
Figure 67 Fluorescein Fluorescence Spectrum Preliminary Testing .....	108
Figure 68 Fluorescein fluorescence emission spectrum measured with spectrometer .....	110
Figure 69 Excitation LED spectrum measured with spectrometer .....	111
Figure 70 First part of optical setup demo.....	112
Figure 71 Second part of optical setup demo .....	114
Figure 72 Integrating sphere reflectivity vs wavelength .....	114

## Table of Tables

Table 1 Hardware Requirements .....	3
Table 2 Software Requirements .....	4
Table 3 Optical System Requirements.....	5
Table 4 Photodetector Comparison Table .....	12
Table 5 Consideration for Prototype Lens Holder Table.....	31
Table 6 Electrical Component Table .....	34
Table 7 Optical components & brief descriptions .....	36
Table 8 Safety Requirements Table .....	42
Table 9 Components in previous excitation optical sub system & properties .....	46
Table 10 Fluorescence Detection Subsystem Components & Properties .....	55
Table 11 Paraxial Ray Trace with Resulting Filter Angle of Incidence & Blue Shift Table.....	63
Table 12 Power Regulator Testing Procedure .....	90
Table 13 Power Switch and USB Testing Procedure .....	91
Table 14 Battery Protection Testing Procedure.....	93
Table 15 Battery Charger Testing Procedure.....	94
Table 16 Photodiode Testing Procedure.....	95
Table 17 WiFi Testing Procedure .....	96
Table 18 LED Driver Testing Procedure.....	98
Table 19 Conversion factor testing procedure .....	98
Table 20 Device Power Up Testing .....	99

Table 21 Navigation Functionality Testing Procedure ..... 100  
Table 22 Web Client Connection and Navigation Testing Procedure ..... 101  
Table 23 Home Page Testing Procedure ..... 102  
Table 24 Configuration Page Testing Procedure..... 103  
Table 25 History Page Testing Procedure ..... 103  
Table 26 Optical Design System Preliminary Testing Procedures..... 108  
Table 27 Preliminary Test Setup ..... 109  
Table 28 Required Optical Components for SD1 Optics Demo..... 112  
Table 29 Optical Demo Procedure ..... 113  
Table 30 Troubleshooting Steps ..... 118  
Table 31 Milestone Table..... 120  
Table 32 Cost & Component Budget Table ..... 121

# **1 Executive Summary**

In modern day technology there are many different types of optical detection techniques that are used widely around the world. From microscopy to fluorescence detection. Fluorescence detection has been around since 1845 and since then is used throughout biology and medicine to deduce certain characteristics about a certain ailment, illness or even genes that someone has. One of the main benefits of doing fluorescence detection is accuracy and repeatability. Because of modern day technology, scientists can detect ailments on a very small scale very accurately either through imaging or sensing. Most fluorescence detection devices use imaging to show that something has been detected or not, while this method is very expensive, the cheaper alternative is using a sensor for the detection. Currently on the market there are a few fluorescence sensor devices, but they are bulky and unable to be carried around easily. Being able to take a fluorescence detection machine on the go will make data analysis of samples faster and easier without having to get back to the lab.

The goal of this project is to create a fluorescence detecting device to detect the fluorescent light emitted by markers using a photodetector. The type of fluorescent light and concentration of light emitted by the markers is used to determine a certain ailment, gene or illness that a person may have. One of the largest issues about fluorescent detection devices is the portability of the device. To solve this issue, we will be using revolutionary thin filters to make the overall design compact and less expensive than most fluorescence sensing devices.

Some key functions of this project are that there will be an LED which produces light that passes through a band pass filter allowing only the excitation wavelength to pass through. From there the light will shine on the sample, exciting the fluorescent material in it causing the emission of a unique frequency of light that is different from the exciting light. The light will then pass through a bandpass filter that will only allow the emission light from the markers to pass, and a focusing lens will be used to collimate the emitted light from the sample onto the optical filter before the sensor. The microcontroller will sample the signal multiple times and generate a reading for the total amount of fluorescent material in the sample. The user will be able to calibrate the device and operate it using a touchscreen interface directly on the device or transmit the data to a cell phone or computer and be controlled via the connected device.



## **2 Project Description**

### **2.1 Motivation and Goals**

#### **2.1.1 Core**

Create a device which accurately and precisely excites fluorophores (Fluorescein sodium salt a type of fluorophore) of particular interest that attaches to antibodies (Lyme's disease antibodies IGg and IGm a type of antibody). Create a device which accurately and precisely measures the concentration of fluorescent emission from the fluorophores. Compact design with reduced weight and bulk compared to other fluorescent sensing devices. Portable design for use in the field outside of the lab. Visual display of sample concentration of fluorophores representing a particular ailment detected through fluorescence

#### **2.1.2 Advanced**

Design a system to switch out optical filters to excite different markers and detect their fluorescence.

#### **2.1.3 Stretch**

Design a way to bend the thin optical filters so they can act in the place of lenses. Transmission of data via Bluetooth or Wi-Fi. Integrate the device with additional filters to detect antibodies for different diseases that are not already integrated

### **2.1 Project Objectives**

Select an ailment/marker to detect(multiple). Determine the wavelength of each ailment/marker. Determine fluorescence emission wavelength of light for each marker. Determine lenses and filters for the correct wavelength of light confinement and transmission. Determine optical system spacing for efficient fluorescence detection and compact design. Choosing LED with a spectrum that includes excitation wavelengths. Choosing a photodetector with effective sensitivity. Designing photodetector circuit for converting analog signal to digital signal for microcontroller. Design Software to read sensor signal and calculate concentration of fluorescent material. Create Simple to use interface for taking readings and configuring sampling settings

## 2.2 Requirement Specifications

### 2.2.1 Requirements for Hardware:

1.0	System shall contain a light emitter for exciting samples
1.1	System shall contain a light collector able to accurately sample the concentration of fluorescent material in a sample
1.2	System shall allow switching either manually or automatically between different optical filters for measuring different frequencies of emitted fluorescence
1.3	System shall accurately measure analog signal from light sensor
1.4	System shall be battery operated using commonly available batteries, or rechargeable non-user-replaceable battery
1.5	System shall include serial port for programming microcontroller
1.6	System shall contain a local or remote display for viewing sample data, and editing configuration
1.7	System shall contain a microcontroller for sampling data and calculating output, as well as operating display, and accepting user input to adjust parameters of sample collection calculation
1.8	Circuitry will be small enough to fit inside custom enclosure, and be on a custom PCB <sup>i1</sup>

Table 1 Hardware Requirements

### 2.2.2 Requirements for Software:

1	Software shall have a simple to operate GUI for taking samples, and calibrating sensor either on the device or wirelessly transmitted to another device
1.1	Software shall have a display with a Graphical Interface for user interaction
1.1.1	Software shall interface with a button for control of the on-device display and features.
1.2	Software Shall have web interface with the ability to control the device, and adjust configuration
2	Software shall be able to record fluorescence readings

2.1	Software Shall have the ability to turn on and off a PWM signal to an LED Driver
2.2	Software Shall have the ability to communicate via I2C with Analog to Digital Converter and sample its value at a user specified rate
3	Software shall have the ability to calibrate the fluorescence calculation to increase the accuracy
3.1	Software shall have calibration ability for the raw value from the sensor to calibrate it to a known light source
4	Software shall be able to store calibration profiles for different excitations
4.1	Calibration profiles shall contain various settings for configuring the device reading
4.1.1	Calibration profiles shall contain a parameter for number of times to read sample for averaging
4.1.2	Calibration profile shall contain a parameter for LED intensity
5	If an automated filter switching mechanism is required, precisely control filter actuator to position different filters for different frequencies of light in front of the emitter and detector.
6	Software shall run on an embedded microcontroller like the ESP32

*Table 2 Software Requirements*

### **2.2.3 Requirements for Optical System**

3.0	The system shall be able to confine and collect fluorescent light for the photodetector.
3.1	The longpass optical filter shall be curved such that fluorescent light emission and light excitation light reflected off the sample will enter the filter at a normal angle of incidence. For case 2 and progress toward stretch goal of curved filter usage.
3.2	The longpass optical filter shall only allow light of the fluorescent emission wavelength of around 515nm to pass through and filter out all other wavelengths of light.
3.4	A lens shall be positioned at a distance from the LED that enables collimation of reflected excitation light onto an optical filter, so that the rays hit the optical filter at a normal incidence angle, before the photodiode at a short distance away.

3.5	The LED shall emit a spectrum of light with the highest intensity peak centered within the desired excitation wavelength range (~460nm for fluorescein sodium salt).
3.6	The optical system will have a spacing between optics that allows for a compact design of the optical system.
3.7	The optical system shall have a limit of detection (LOD) <5 picomolar (pM) for fluorescence emission detection <sup>2</sup>
3.8	The LED, optical filter, photodetector, and plano-convex lens will be rotated at an angle with respect to the normal of the sample fluorophore solution so that both the fluorescent light emission and reflected LED light will be detected and cutoff from reaching the photodetector respectively

*Table 3 Optical System Requirements*

## **2.3 House of Quality**

The House of quality is a strategy for measuring the general significance of prerequisites and deciding whether usefulness necessities have been planned alright to meet client assumptions and item strength. Positive relationship (+) shows that the characteristics work as one with each other to expand each other's viability or probability of event. Negative relationship (-) address characteristics that contention with each other. Considering weight of significance of every quality, the need of the amplifying one contrarily connected quality over another can be evaluated. Necessities with no connection (blank) neither further develop each other nor struggle each other.

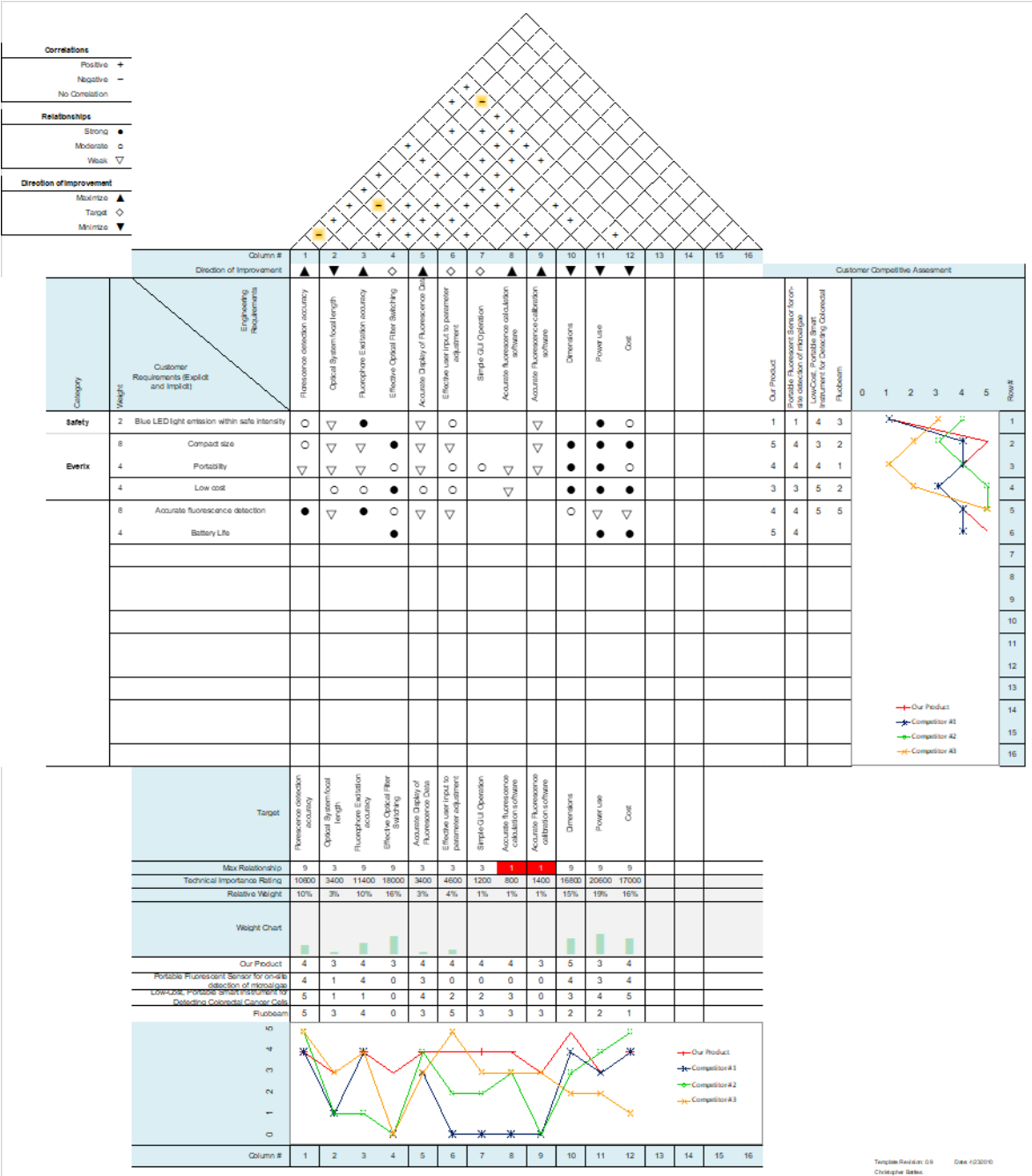

Figure 1 House of Quality

The client-based requirements are Blue LED light emission is within the safety standards for the human eye, long battery life, Compact size, Low cost and accurate fluorescence detection.

The relationship grid of Figure 1 represents a correlation between client expectations and functional requirement which can be found in the requirement specifications section of the house of quality figure. Because the client in our senior design project are the sponsor and the professor reviewing the requirements specified. The major concerns that the client had for our project was accurate detection of the fluorescence dye and a low-cost design. We determined that the product would need to be placed on a flat surface or handheld

An analysis of the data in the house of quality found in Figure 1 reveals that the design constraints requiring the light display, to be portable, lightweight, user-friendly, and small are most strongly fulfilled by our technical specification requiring the total structure to be as compact as possible. Various other technical specifications meet these key requirements, one of these would be making a web-based service in order to make design more compact. Of particular interest are qualities that rate high in necessity yet have only minor correlation with the listed technical specifications. While the specifications of the device are highly designed around it being portable, few of the requirements are designed with its robustness in mind. Many additional specifications may be added to the requirements in the future.

Opportunities for future necessities might include:

- Making use of strong heat resistant adhesive to place and secure components.
- Casing which won't be affected by tension, hotness, and power related with moving to forestall deficiency of part usefulness.
- Putting holds on the lower part of the packaging to keep it from sliding around on smooth surfaces or during transportation.
- Managing the temperature of within the construction by remembering ventilation through holes or cuts for the case.
- Adjusting the heaviness of parts inside the design uniformly to keep it from wobbling or shifting over the long haul or during use.

It is too soon to choose precisely what might impact or effect technical problems, so the experienced troubles may essentially be examined as an experimentation troubleshooting and equipment testing rather than being substantial necessities. One way we can keep such errors from occurring at the plan state or late being developed is by anticipating that these problems should occur and setting a hard cutoff time on when all sensible investigating and equipment update should be finished.

### ***3 Research Related to Project Definition***

### **3.1 Existing Similar Projects and Products**

While the following devices are not used in the detection of Lyme disease antibodies, the filters and excitation sources in these devices can be changed to allow them to detect Lyme disease. As portable fluorescence detecting devices, the following devices are existing products with similar goals and functions to our device.

An existing portable fluorescent device, for on-site detection of micro-algae concentration, incorporates multiple LEDs, a photodetector, a dichroic optical filter, and a color optical filter [1]. This device is considered to be at a low cost to produce. The device has a vacuum pump for collection of samples [1]. The device has a covered enclosure. The dichroic filter and color filter are of a thickness of 3mm and 1mm respectively [1]. These filter thicknesses are larger than the thickness of the filters the Everix produces. Everix's thin optical filters will prove advantageous in making our device more compact than other competing devices such as this one. This portable fluorescent sensing device detected fluorescence using photocurrent seen by a picoameter instead of a local or remote display system [1]. We plan to integrate our device with a display so that our device will be portable without having to bring along extra peripherals such as display systems. The micro-algae fluorescence sensing device has an effective size of around  $90 \times 50 \times 20\text{mm}^3$  [1]. We are working at making our device more compact and portable than other fluorescence sensing devices. To achieve this goal, we intend to have a maximum size of our device to be  $85 \times 45 \times 20\text{mm}^3$ . The highest concentration measured with the micro-algae detection device was 19,000 cells/ $\mu\text{l}$  [1]. Since our device will be detecting fluorophores attached to Lyme disease antibodies our concentration will be in molarity or parts per million (mg/liter). We intend to have a limit of detection of  $<5 \text{ pM}$  for our device. The limit of detection of the micro-algae detection device is not given for comparison with the limit of detection that we intend to have.

Another existing portable fluorescence detection device worth examining is a fluorescent imaging device for detection of Colorectal Cancer cells [2]. This device is described to be portable and low cost. At an effective device cost of \$224.37, I believe it has achieved its goal of affordability [2]. An important distinction between this fluorescence detection device and ours is that this device provides an entire image of the fluorescing cells whereas our device is designed to sense the quantity of fluorescent concentration in a sample. This Colorectal Cancer cell fluorescence detecting device has a light weight of approximately 0.16kg [2]. To make our device effectively portable, our device should have a light weight equal to or less than the 0.16kg of the portable cancer imaging device. A flashlight is used as the light source for this device [2]. Having a flashlight as a light source allows increased noise or error from flashlight emission light reflecting to the photodetector and being falsely considered to be fluorescent light. Our device will use bandpass optical filters to mitigate the possible LED light reflected to our photodetector. The Colorectal Cancer cell detecting device uses 3 optical filters including a dichroic, long pass, and excitation filter [2]. The Colorectal Cancer cell detecting device has an

approximate size of  $80 \times 40 \times 32\text{mm}^3$  [2]. This size only includes the size of the sample chamber and does not include the size of the flashlight which would have to accompany the device in order to achieve effective use. Our device will use two thin optical bandpass filters, which will allow our device to achieve a more compact size when compared to this Colorectal Cancer detection device. This Colorectal Cancer detection device uses a 3D printed enclosure and has a built in LCD display system [2]. We also plan to use 3D printing to create a custom enclosure for our device and intend to have a display system built into our device.

## **3.2 Strategic Components and Part Selections**

### **3.2.1 Photodetectors**

There are multiple types of photodetectors designed for different applications. In the following sections we give a brief explanation of how each type of photodetector works as well as the pros and cons of each device. This allows us to make a more informed decision on what photodetector we can effectively use in our device.

Most photodetectors are semiconductor devices which absorb photons, converting the energy of the light absorbed into electrical current called photocurrent. This current enters the circuit which the photodetector is connected to. The light detected with a photodetector is detected in the outer circuit by the association of incident optical power to the photocurrent produced in the circuit.

#### **3.2.1.1 Photoconductor**

There are several types of photodetectors. The simplest type of photodetector is the photoconductor (PC). The photoconductor, as defined on the website RP-Photonics, is a slab of intrinsic (low conductivity) semiconductor material [3]. The photoconductor requires an external voltage to operate. Photoconductors are cheaper than photodiodes, but have a slow detection speed, a low sensitivity, and exhibit a nonlinear response with respect to optical power input and photocurrent output [3]. The low cost of photoconductors would help lower the cost of our device, but the slow speed of detection, low sensitivity, and nonlinear response make it a bad candidate for integration into our device's detection system. Photoconductors are highly sensitive to low frequency optical signals but have a low sensitivity to optical signals with high frequencies [3]. Since our device will be detecting a fluorescein emission at a wavelength 520 nm, a frequency low enough that it would be best to consider other options for a photodetector for our device.

#### **3.2.1.2 Photodiode**

The most used type of photodetector is the photodiode (PD). A photodiode is a p-n or p-i-n junction that is normally operated under an applied reverse bias [3]. However, unlike the photoconductor, the photodiode has a high enough built-in electric field to produce



photocurrent upon the absorption of a photon [3]. When the photodiode is operated in reverse bias the depletion region width and electric field increase. The photodiode has a linear relationship between the intensity of light absorbed and the photocurrent output into the circuit [3]. Photodiodes are considered to be very compact, fast, exhibit a high quantum efficiency and a high dynamic range [3]. These qualities of a photodiode, as well as the photodiode's linear response make it the most advantageous photodetector to implement in our device.

### **3.2.1.2.1 Avalanche Photodiode**

One photodiode is an avalanche photodiode (APD). An avalanche photodiode is a semiconductor photodiode operated with a high reverse bias voltage (tens or hundreds of volts) [3]. This large reverse bias voltage creates a very strong built electric field which enables this device's so called avalanche process, which effectively amplifies the photocurrent output by a significant factor [3]. It should be noted that this amplification is not as significant as the amplification of photocurrent found in a phototransistor which will be outlined in a later paragraph. In the site RP-Photonics it is noted that for precise measurements of low light powers, avalanche diodes are hardly suitable since their responsivity is not nearly as well defined as that of a p-i-n diode [3]. Since fluorescence emission from a fluorophore is typically considered to be of a low light power this would suggest that although APDs have amplified photocurrent, for our device an APD would not be the most effective photodetector to implement. APDs have a lower quantum efficiency than that of some photodiodes [3].

### **3.2.1.3 Phototransistor**

Phototransistors are semiconductor devices like photodiodes but they have an internal amplification to the photocurrent output into the circuit. This internal amplification allows the phototransistor to achieve higher responsivity when compared to the APD or photodiode [3]. The high responsivity due to the internal amplification of the phototransistor makes it advantageous to implement into our device so to enable a higher responsivity to the fluorescent light emitted by the fluorophore which we plan to detect. This does not necessarily mean that the phototransistor will have a higher signal to noise ratio compared to the photodiode, since the photocurrent noise picked up by the phototransistor is also amplified [3]. A couple relevant drawbacks of the phototransistor include the less than linear response to incident light and the stronger temperature dependence compared to that of a photodiode due to fluctuation of gain based on temperature levels [3]. The largest drawback of using a phototransistor compared to other photodetectors is the substantially lower speed of detection for the device [3]. The rise and fall times of the phototransistor are typically of an order of a few microseconds [3]. This lower speed of detection will be taken into consideration when deciding what photodetector to integrate into our device.

### **3.2.1.4 Phototube**

Phototubes are another type of photodetector which uses a vacuum tube or gas-filled tubes where the photoelectric effect takes place [3]. The photoelectric effect is when photon energy hits a metal or semiconductor interface [3]. Some of these photons can be absorbed by the metal or semiconductor interface leading to absorption of photons as well as the emission of electrons [3]. These emitted electrons create a photocurrent which is then detected within the larger circuit. A bias voltage is applied to the anode and cathode of the phototube in order for incident photons to be detected [3]. One thing that the phototube has going for it is a large usable dynamic range, for example with photocurrents of a few picoamperes (pA) to a few microamperes ( $\mu$ A) [3]. It should be noted however that the maximum allowed photocurrent is far below that of a photodiode [3]. Another advantageous feature of the phototube is that there is hardly any temperature influence on its responsivity [3]. Phototubes can have a lower dark current than other photodetectors leading to a higher signal to noise ratio [3]. Phototubes can be made with a large detection area and high detection bandwidth [3]. For UV applications the phototube has a higher stability compared to that of semiconductor photodetectors [3]. If a phototube can be found which detects within the 350 to 550 nm range than a phototube could be integrated into our device giving us a higher dynamic range, resistance to temperature influence on the response of our detector, a lower signal to noise ratio and higher stability. These are all advantages of using a phototube in our device. Some disadvantages that come with usage of a phototube in our device include a low quantum efficiency, higher sensitivity to mechanical vibrations and shocks, a high operational voltage, and have a very low amount of photocurrent current produced. The high sensitivity to shocks and mechanical vibrations in the phototube make it incompatible with our device's design goal of portability which inherently requires movement and vibrations along with an environment where how the device is being held for fluorescence detection will not be as stable as a bench top laboratory environment. The higher voltage that this device needs to operate would require our power supply within our device to be of a higher power, which is something that we are looking to limit so that our device could be used for long periods of time without needing to be recharged. The optical power emitted in fluorescence is typically of low optical power level which with the use of a phototube, the photocurrent output into the circuit will be low leading to a more difficult integration into the overall circuit of our device.

#### **3.2.1.4.1 Photomultiplier Tube**

A photomultiplier tube (PMT) is a special type of phototube, which use electron multiplication processes to obtain an increased responsivity [3]. PMTs can have a high detection speed and a large active area [3]. The high detection speed, increased responsivity, and compacted design size make it a better candidate for implementation in our device compared to that of the typical phototube. They can be substantially more compacted compared to other phototubes. PMTs require a large operational voltage (of the order of 100 V) [3]. The implementation of PMTs in our device would require our device to have a complex power supply system with voltage divider chains and a DC-to-DC converter or the device would need to be connected to a moderately complex power

supply within a power grid [3]. This makes PMT incompatible with our device since it takes away from our design goal of having a portable device which can be used for large periods of time without the need for the device to recharge.

### 3.2.1.5 CCD Sensor

Another common photodetection device is the CCD sensor. The CCD sensor uses the principle of charge-coupled devices to form an image from light incident on the CCD sensor [3]. For the purposes of our device, we intend to detect whether fluorescent light is being emitted from fluorophores within a sample and the concentration of fluorescent light emitted, therefore we do not require an imaging device. Our goal in the creation of a fluorescent sensing device for detection of Lyme Disease antibodies is detection of quality and quantity of fluorescence emitted from fluorophore concentrations and associating this fluorescence with antibodies in the sample. We choose not to make a fluorescence imaging system since imaging systems are more complex and costly to make. Implementing a CCD sensor within our device would move the design of our device beyond our established goals.

### 3.2.1.6 Comparison of different types of photodetectors

Parameters	PMT	PD	CCD	APD	SiPM
QE (%)	<40	<90	<90	<90	<40
Spectral range (nm)	115–1,700	190–13,000	200–1,200	190–1,700	320–900
Gain	$(10^5)–(10^7)$	1	1	<300	$(10^5)–(10^6)$
Rise time (ns)	0.15–13	0.23–10	$(10^6)–(10^8)$	0.01–0.35	0.3–3
Bias voltage (V)	1–2 k	20–30	—	100–500	20–30
Noise	Low	Low	Low	Medium	High

Table 4 Photodetector Comparison Table

### 3.2.1.7 Selected Photodetector

Based on our investigation into the various major types of photodetectors worth considering as candidates for our device, we have chosen to implement a photodiode in our device. The photodiode's compact size means that it can help meet the small size requirements for our device. The photodiode has a spectral range of detection that includes the 520 nm fluorescence emission that we expect from the fluorescein that we will decide limit of detection with as well as nearly any other fluorophore's fluorescence emission wavelength. The linear response of a photodiode allows the fluorescent light intensity to be more precisely detected from the photocurrent compared to other photodetectors. The linearity and added precision from the photodiode will make us a step closer to achieving our device's goal for precise detection of fluorescence light, and therefore concentration of antibodies, and overall detection of Lyme Disease from said

antibodies. The higher quantum efficiency of the photodiode will also add to the accuracy of our device. As shown in the above table, photodiodes have a rise time range of 0.23-10ns, which is relatively fast compared to most photodetectors [4]. The photodiodes fast speed will help our device process the detection of antibodies for Lyme Disease within a small sample concentration.

As stated before, driven examples will be tried to look at light yield versus heat yield and power utilization to decide a viable power and cooling answer for accomplishing project objectives. This can be proceeded as a benchtop test with LED's and a supply of power. This testing will permit the force financial plan to be even more precisely assessed. A Photo Diode that measures at most 5mm x 5 mm will be the choice of photodetector in our system, this was the reached decision by the group after going over all options, size of the system is an especially important category for our project, we want to stay competitive versus other systems already in the market. So, we will be considering the necessary voltage and current measures based on the specific model we go with. There are three main options FDS015 - Si Photodiode, 35 ps rise time, 400 - 1100 nm, 0.018 mm<sup>2</sup> active area, and second FDS025 - Si Photodiode, 47 ps rise time, 400 - 1100 nm, 0.049 mm<sup>2</sup> active area and a third FS100 – Si Photodiode, 10 ns rise time, 350-1100 nm wavelengths, 13 mm<sup>2</sup> active area.

### 3.2.1.8 Calculating Fluorescence Emission Intensity

$$(1) I = 2.303(K')\epsilon bcP_0$$

Equation 1 allows for the calculation of fluorescence emission intensity (*I*) with respect to excitation light optical power (*P*<sub>0</sub>) as well as other factors. Geometry based factors and quantum yield are represented in the constant *K'*. The molar absorptivity is represented by  $\epsilon$  in equation 1. Fluorophore concentration is represented by “c”. The optical path length that the fluorescent light emission travels is represented as “b” in equation 1. An approximate optical path length for the fluorescent light emission from the sample fluorophore concentration at a focal length of 6 mm is 0.945 cm. The molar absorptivity of fluorescein is 70,000 cm<sup>-1</sup>M<sup>-1</sup>. The lowest concentration of fluorophore solutions that we plan to test is 5 picomolar while the highest concentration of fluorophore solution that we plan to measure is 5 nanomolar. The Thorlabs LED465E that we have chosen as our excitation source has a 20-mW optical power at 20 mA.

$$I_{max} = 2.303(70,000 \text{ cm}^{-1}\text{M}^{-1})(0.945 \text{ cm})(5 \times 10^{-9}\text{M})(20 \times 10^{-3}\text{W}) = 15.234 \mu\text{W}$$

$$I_{min} = 2.303(70,000 \text{ cm}^{-1}\text{M}^{-1})(0.945 \text{ cm})(5 \times 10^{-12}\text{M})(20 \times 10^{-3}\text{W}) = 15.234 \text{ nW}$$

The calculated fluorescence emission intensity for fluorescein sample concentrations without accounting for changes in optical design or geometric constant factors relating to *K'*, ranges from 15.234 nW with a concentration of 5 picomolar to 15.234 μW with a concentration of 5 nanomolar.

### 3.2.1.9 Calculating Photocurrent & Responsivity from SNR

$$(2) SNR = \frac{I_{ph}^2}{I_s^2 + I_j^2}$$

$$(3) I_j^2 = \frac{4k_B T B}{R_{eq}}$$

$$(4) I_s^2 = 2q(I_{ph} + I_D + I_B)B$$

$$(5) I_{ph} = -qB(SNR) \pm \sqrt{(q \times SNR \times B)^2 - (2q(SNR)(I_D + I_B)B + \frac{4SNR \times k_B T B}{R_{eq}})}$$

SNR is the signal to noise ratio of a detection system or photodetector. The minimum signal to noise ratio that we would want in our device would be when the signal is three times the noise level detected by our device. For our device we want a high signal to noise ratio and a high responsivity for our photodiode but the minimum responsivity that we are looking for a photodiode to implement into our device can be found by reverse engineering the minimum responsivity from the minimum signal to noise ratio that we desire. The rms photocurrent produced when light is incident on a photodetector is represented by  $I_{ph}$  in equation 5.  $I_s$  represents the shot noise which is primarily due to generation recombination noise that is caused by random fluctuations in generation and recombination within the semiconductor. Dark current represented by  $I_{ph}$  is a significant contributor to the shot noise in a photodiode.  $I_B$  represents background current. Johnson noise also called thermal noise is represented by  $I_j$  and is caused by random motion of carriers with an average energy of the Boltzmann ( $k_B$ ) constant times temperature (T) in kelvin.  $R_{eq}$  represents the equivalent resistance of the external circuit which is connected to the photodiode. Our preliminary testing of the fluorescent signal spectrum shows that the fluorescent emission has a spectral bandwidth of 45.23 nm which can be converted to  $6.633 \times 10^{15} \text{ Hz or bit/s}$ . The largest dark current found in the photodiodes being considered for our device is a current of 0.3 nA. The current equivalent resistance being considered for the circuit connected to the photodiode is 100 k $\Omega$ . By plugging in these values and constants into equation 5, the minimum photocurrent value is found to be 0.523  $\mu\text{A}$ .

$$(6) R = \frac{I_{ph}}{P}$$

Equation 6 is a formula for solving for responsivity given photocurrent ( $I_{ph}$ ) and incident power (P). A photocurrent value 0.523  $\mu\text{A}$  was calculated through reverse engineering from given constraints and a minimum signal to noise ratio of 3. The incident power emitted by the fluorescein fluorophore was approximated to be within the range of 15.234 nW to 15.234  $\mu\text{W}$ . The minimum responsivity required in our photodiode can be calculated from equation 6 using an incident power value of 15.234  $\mu\text{W}$  and a photocurrent of 0.523  $\mu\text{A}$ . The minimum responsivity that we are looking for in a photodiode is 0.0343 or 3.43%.

All of the potential photodiodes that we have compared under the Strategic Components section of this document have responsivity values larger than the minimum responsivity of 0.0343 required for our system. The responsivity is not the only factor in the determination of what photodiode we should use in our device. Another important factor is the size of the active area of the photodiode. Since the light passing through our plano-convex lens will be mostly collimated, the light passing from the plano-convex lens through the optical filter to the photodiode will be at angles between 0 to 25 degrees. This small incident angle along with the close distance between the plano-convex lens and the photodiode necessitate that we choose a photodiode with as large an active region as possible so that a large amount of light can be collected by the plano-convex lens and subsequently a large amount of that light collected will also be detected by the photodiode. Upon considering both the size factor and responsivity we have decided to choose the FS100 photodiode which has an active area of  $13 \text{ mm}^2$  (3.6 mm by 3.6 mm) which is the largest active area which could be found in photodiodes with responsivities in the 520 nm range. The responsivity of the FS100 photodiode is 0.188 for a wavelength of 520 nm which is the peak fluorescence wavelength of fluorescein.

### 3.2.1.10 Possible Photodiode Circuit

The recommended circuit for the diode is shown in Fig 2 with the gray enclosed area being the Noise filter, this is a necessary addition since the detector is limited by the thermal noise of the load resistor.

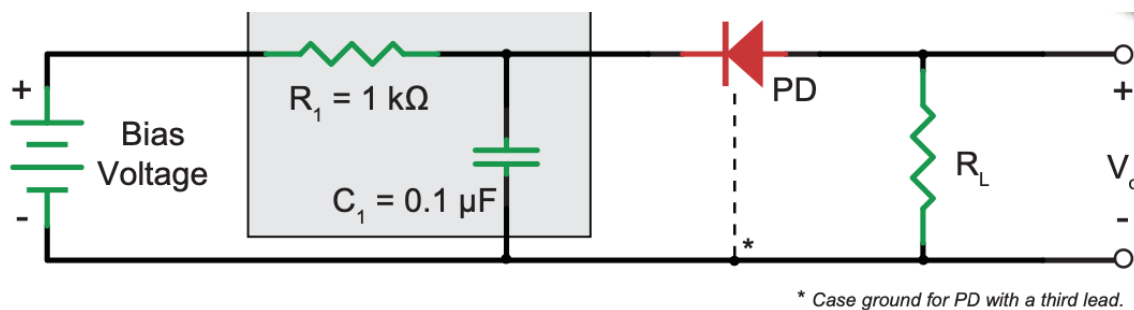

Figure 2 Recommended circuit for Photo Detector Diode

### 3.2.2 LED for Excitation

The purpose of the LED is to cause the sample to fluoresce, the LED picked by the group has been the OSCONIQ P 3030 further classified as GV QSSPA1.13-JZKZ-V1V6-1 with a ESD withstand voltage of 8kV and this spectrum produced is what we measure in order to determine the relative type of sample. The reason we chose this part is that the frequency of light produced is within the specification which is stated at 400-1100nm with a beam size and intensity that will work for our application. The power draw is acceptable with 100-1300 mA of current and a forward voltage of 2.85 Volts.

This LED meets the size specifications for our product design which is why is our first choice. However, there is a close second option in case the first is not available once we start the process of prototyping the product and the first choice of LED in charge of exciting the sample in order to fluoresce is out of stock, this would be the LED470L - 470 nm LED with a Glass Lens, 170 mW, TO-39. This LED would have a power dissipation of 500mW max with a forward voltage of 3.2-3.8V at 350mA. The Center wavelength at the 350mA would be at 470nm.

### **3.2.3 Led Driver**

An LED driver will be required to supply the output power to drive the LED from mcu PWM signal. For the size and power of LEDs the team has investigated, the output of the microcontroller will be too weak at less than 40 mA. So, a simple led driver will be made using a MOSFET to switch power to the LED, and a DC power supply will be required to drive the proper voltage to the led. The LED driver will allow the microcontroller to drive a powerful LED to provide enough excitation voltage to the sample for fluorescence reading. The microcontroller will be able to vary the intensity of the LED using PWM signal to allow user to adjust this when calibrating their sample collection depending on the amount of light needed to successfully excite a specific marker. The driver should be able to fully turn on and off the LED and provide full power for maximum brightness. The driver will also crucially act as a constant current source, allowing the team to precisely set the current usage of the LED so it does not oversaturate and burn up.

### **3.2.4 Indicator LEDs**

The device will have a built in display, so not too many indicator LEDs will be required, but a few will be added in the charging circuit to indicate when the device is being charged, and when the battery is fully charged.

### **3.2.5 Battery**

There were a few options the team looked into when it comes to batteries to power the device. These consisted of Ni-MH, Li-Po, and lastly Li-ion. Once the research and further testing is completed, we will land on one option and use this to power our electrical system. In order to reach a conclusion, we went over the pros and cons for each battery option. NiCads (Nickel Cadmium) were not considered into our battery options since they are not as power dense, and performance is a very important factor

#### **3.2.5.1 Nickel Metal Hydride**

Also known as "NI-MH" are very commonly used rechargeable batteries, they likewise come in many common sizes like AA and AAA. These are a decent swap for standard

alkaline batteries. The battery cell voltage is 1.25V per cell, that is not exactly the 1.5V of alkalines however more than the 1.2V of NiCads. The reason we decided not to use them is their high self-discharge rate. Even though battery innovation has improved this facet of NI-MH batteries and there are a couple of low-self-discharge batteries available, by and large they could not compete with lithium batteries in terms of energy density, current output, or size.

### **3.2.5.2 Lithium Polymer**

Li-ion polymer or Li Po batteries have many advantages. However they also have many disadvantages. Among these are cost, energy density, and a memory effect. For these reasons, we did not use a Lithium Polymer Battery in our design.

### **3.2.5.3 Lithium Ion**

Lithium-ion batteries have a higher energy density than most other battery options. Self-release/discharge is another strong advantage when compared to other forms of rechargeable batteries. This is a common drawback of many types of rechargeable batteries, but it is not too bad with lithium-ion batteries. Lithium-Ion batteries typically have a very low self discharge. A lot lower than that of other rechargeable cells. Typically Self-Discharge is ordinarily around 5% in the initial 4 hours after being and an additional 1% to 2% each month. Their next advantage is their cell voltage; The voltage delivered by common lithium-ion cell is around 3.6 volts. This enjoys many benefits. Being higher than that of the standard nickel cadmium, nickel metal hydride and surprisingly standard soluble cells at around 1.5 volts and lead acid at around 2 volts for every phone, the voltage of every cell is higher, requiring less cells in numerous battery applications. The main disadvantage is wear on the battery cells over time. All rechargeable batteries do wear out, but typical lithium ion batteries have a pretty finite number of charge cycles. Batteries lose capacity with every wear cycle, and lithium ion is not immune to this. With the advancement of li-ion innovation however, the number of charge cycles is increasing. They are also very common batteries and can easily be replaced when they reach end of life. There are certain things that can be done to reduce the wear on the batteries, but without strict discipline these practices will have little impact. It is also worth noting that Lithium Ion cells must be kept relatively cool, and should not be stored at a full charge, or fully depleted for maximum longevity.

### **3.2.5.4 Final Battery Selection**

Both lithium-ion and lithium-poly batteries would be appropriate for our project with high energy density, and high current output. After our Team reviewed all these options, we decided to use a 3.6 V, standard 18650 cell to power our device. Because the device is fairly low power, 1 cell will provide plenty of power for the device to last quite some time.



### **3.2.6 MCU**

These will be used for our first design although probably not for the final design. Our group first had to choose between a MCU otherwise known as a microcontroller and a MPU which is considered a microprocessor. These come with their differences to take into consideration when choosing between MCUs and microcontroller the main one being power, clockspeed, RAM and if they run 32-bit or 64-bit. In our case we need a board that is capable of WiFi and Bluetooth communication. An MPU is larger than the average microcontroller, take as example the Raspberry Pi, it uses more power, has a clock speed of between 700MHz-1.5GHz, and a RAM of between 1-8GB as stated in their specifications. Also, the Raspberry Pi, unlike microcontrollers, can run both 32-bit and 64-bit. Next would be the Arduino Uno which would be considered a microcontroller board based on the ATmega328. It has 14 digital input/output pins (of which six can be used as PWM outputs), six analog inputs, a 16 MHz crystal oscillator, a USB connection, a power jack, an ICSP header, and a reset button as stated in the specifications.

#### **3.2.6.1 Final MCU Selection**

The microcontroller which we selected for our project is the ESP 32. The purpose of this microcontroller is to send PWM signal to the LED driver, capture values from the photodetector, serve WiFi network and web server, and interface with display to give information to the user. The reason we selected this part is that it is a low cost, low power component which has enough GPIO pins to interface with each of the components in our project as well as easy to use software and libraries. ESP32 will safely operate in a range of temperature conditions. – 40°C to +125°C. Designed for cell phones, wearable hardware and IoT applications, ESP32 accomplishes super low energy utilization, and also has nice to have features like a built in WiFi antenna and transceiver. ESP32 requires very little circuitry to get working. Has most of what it needs under its included RF shield, making it easy to add into a PCB.

### **3.2.7 Display**

#### **3.2.7.1 Possible Display Choice**

One option for the display of our product would be the Adafruit 1.44" Color TFT LCD Display with MicroSD Card breakout [ADA2088] this LCD utilizes 4-wire SPI to convey and has its own pixel-addressable casing cushion, and it tends to be utilized with ESP32 microcontroller like we are using in our design already. The 1.44" LCD has 128x128 shading pixels. In contrast to the minimal expense "Nokia 6110" and comparative LCDs. It utilizes a sensitive flex-circuit connector just as a super low-dropout 3.3V controller and a 3/5V level shifter so you can utilize it with 3.3V or 5V force and rationale. The aspect ratio is what makes it our second choice when compared to the HiLetgo 0.91" IIC I2C Serial OLED LCD Display SSD1306 128x32 3.3V/5V AVR PIC for Arduino STM32 Schematic OLED Display module.

### **3.2.7.2 Chosen Display**

Our display of choice will be the HiLetgo 0.91" IIC I2C Serial OLED LCD Display SSD1306 128x32 3.3V/5V AVR PIC for Arduino STM32. This display is 128x 32 pixels which will give us plenty of room to convey what we need to the user for the Local HMI. This is an OLED display so there is self-illumination. It uses the I2C bus for communication, so only two data lines are required to connect to the microcontroller, and runs on the SSD 1306 display driver. Furthermore, the display can run on 3.3V this means that our unit can use the same voltage regulator as will be used for the Microcontroller you can see the dimensions of the screen and in Fig 8 you can see the schematic of the display module

### **3.2.8 Analog to Digital Converter**

#### **3.2.8.1 Initial Choice**

An analog to digital converter is required for this project to convert the output of the photodiode amplifier from its analog value to a digital value that can be used by our microcontroller with very high precision. Our team initially selected the ADS1115 ADC is a low-power, 16-bit precision ADC which would work well for this purpose. At 16-bit precision, it should have just enough resolution. It is also widely available on breakout boards that could easily be used for breadboard testing. Unfortunately, the chip was not available from any suppliers except for already populated on breakout board. The team considered using one of these breakout boards in our final design, but decided not to for the sake of board size.

#### **3.2.8.2 Final ADC**

After supply chain failure of the ADS1115, the team settled on the more expensive MCP3426, which is part of the (MCP3426/7/8) family of devices that are low-noise and high-precision 16-bit DeltaSigma A/D converters ( $\Delta\Sigma$  A/Ds) made by Microchip. These devices share the resolution of 16-bits from the ADS1115, but do come with some unique features. The primary draw to this chip was its availability due to not being as commonly used as the ADS1115, but on the technical side, the one shot feature was a very useful feature to have for this project. It allows the ADC to be turned off when not needed, and triggered when needed in an ultra high sample rate, high precision sampling mode capable of only 1 sample per second. This should provide a good decrease in quiescent current, and increase the longevity of the ADC over time. The MCP3426 has two differential inputs, however we will only be using one of those inputs, and not as a differential input, The LTC 1050 output is a single sided, ground referenced signal. Unfortunately the minimum number of inputs for this device family is 2 so the ADC is a little more powerful than necessary, but does leave future expandability in the component selection because a second analog signal could also be converted and sent to the MCU using the same I2C bus.

### 3.2.9 Battery Protection and Charging

The TP4056, and DW01 were chosen for the battery protection and charging circuits. Charging and discharging lithium batteries poses a potential safety risk if proper protection circuits are not implemented. For that reason the team thought it a better idea to use industry standard charging circuits in a very standard implementation rather than trying to design a custom circuit to handle battery charging and protection.

### 3.2.10 Power Regulator

#### 3.2.10.1 Power Regulator Research

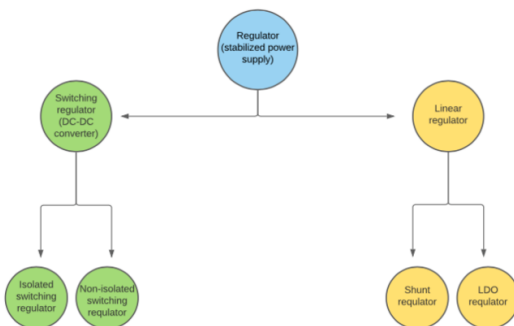

Figure 3 DC-DC Regulator vs Linear Regulator

In a linear regulator:

$$\begin{aligned}\text{Input power} &= \text{Input voltage} \times \text{Load current} \\ &= 5.0\text{V} \times 0.1\text{A} \\ &= 0.5\text{W}\end{aligned}$$

$$\begin{aligned}\text{Output power} &= \text{Output voltage} \times \text{Load current} \\ &= 2.5\text{V} \times 0.1\text{A} \\ &= 0.25\text{W}\end{aligned}$$

Since efficiency = Output power ÷ Input power, the efficiency of a linear regulator is 50%.

Figure 4 Linear regulator efficiency calculation

From this we can see that voltage is provided for a large portion of a period. Essentially, if you attempt to acquire efficiency from the input and output, we get the following:

$$\begin{aligned} \text{Input power} &= \text{Input voltage} \times \text{Load current} \times \frac{1}{2} \\ &= 5.0\text{V} \times 0.1\text{A} \times \frac{1}{2} \\ &= 0.25\text{W} \end{aligned}$$

$$\begin{aligned} \text{Input power} &= \text{Output voltage} \times \text{Load current} \\ &= 2.5\text{V} \times 0.1\text{A} \\ &= 0.25\text{W} \end{aligned}$$

*Figure 5 Switching regulator efficiency calculation*

Computing efficiency from the above condition: Efficiency = Output power ÷ Input power, we get a worth of 100%. This is the reason a Switching Regulator gives high efficiency As shown in Fig 4 and Fig 5. Switching regulator is much more efficient than Linear regulators.

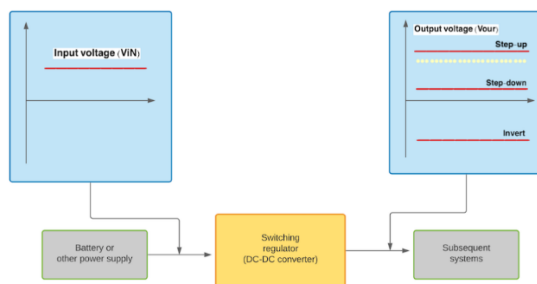

*Figure 6 Switching regulator set up*

The chosen battery produces around 3.7V, and the USB input is a 5V supply. For that reason, a 5V regulator and a 3.3V Regulator will be needed to power the various ICs and components. The team looked at many different power regulator options, and started by discussing the advantages and disadvantages of DC-DC converters and Linear Regulators respectively. A switching regulator like a DC-DC converter has the advantage of increased efficiency due to the nature of a switching regulator, but a higher quiescent current than a linear regulator. Linear Regulators on the other hand, have very low quiescent current, but tend to be less efficient, because they convert excess energy into heat. Because our device will not be left powered for long periods while not in use, the team has chosen to use a DC-DC converter for the 5V Regulator.

### **3.2.10.2 5V Regulator Selection**

Another important aspect of the power system is having both a battery and USB power supply, and allowing the battery to be charged when the device is plugged in. For this purpose, the device needs the ability to switch between battery power, and USB power,

so that the battery is not being put under load while the charger circuit is active. Otherwise the loaded battery voltage might be lower than it actually is and the charging circuit may overcharge the battery. For this purpose the team discussed various options like only running the device on battery power, or using a transistor circuit to disconnect the battery from the circuit when 5V power is present, but the team decided to use the LTC 3118 with PowerPath technology to serve this purpose. The regulator features dual inputs, a single output with configurable output voltage, and Input priority that can also be configured. The team will configure the LTC3118 to always use 5V from usb when available and only use battery power when the 5V power is disconnected. This chip will serve to protect the battery as well as to generate the 5V rail.

### 3.2.10.3 3.3V Regulator Selection

To power the microcontroller, a 3.3V supply is required. A simple resistor could be used but this would not be very efficient and would create excess heat inside the device. Instead, the LM3940 was selected. It is a very simple regulator that is very commonly used with the ESP32. We chose it for its compact size and simple use. Only require input power, output power, and ground connections. The LM3940 will take 5V power from the power regulator and convert it down to 3.3V for the microcontroller.

## 3.2.11 Optical Filter

### 3.2.11.1 Types of Filters Analysis

There are two main types of filters used is fluorescence sensing and, in our case, fluorescein detection which are bandpass filters and long pass/ short pass filters. In this application both of these filters have their advantages and disadvantages. There are a few key ideas when choosing an optical filter, thickness, optical density, flexibility, and transmission level.

#### 3.2.11.1.1 Bandpass Filter

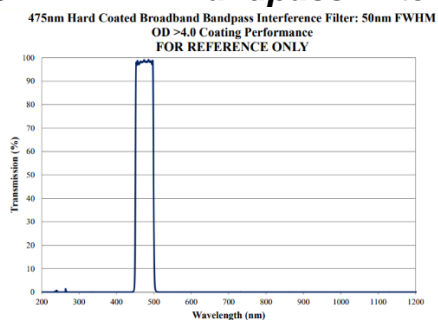

Figure 7 Nano-meter bandpass optical filter, Edmund optics

The bandpass filter in Fig. 8 is an example of what could be used for the emission of the LED. Although this filter has a high OD level, it is very thick and would require the demo to exceed the required specifications [5].

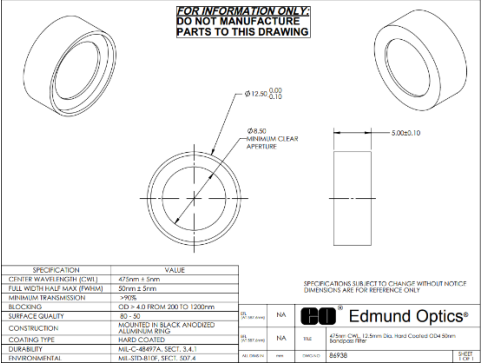

Figure 8 PDF drawing of 50 nm bandpass filter from Edmund optics

As can be seen in Fig. 9 Edmund optics filters are all very thick, including their long pass filters. The thickness of Edmund's optics filters would not allow the system to be scaled down enough to meet the design constraints. Because of this we will be using filters from a company called Everix which are ultra-thin and can be bent and manipulated in a way to make the design a lot smaller. Due to the new optical design setup, there will only be one filter which is for the excitation of the fluorescein. The excitation wavelength of fluorescein is 520.90 nm tested in the lab. A long pass filter of 500 nm cut in wavelength would allow only the excitation wavelength to pass through and not LED wavelength.

**3.2.11.1.2 Longpass Filter**

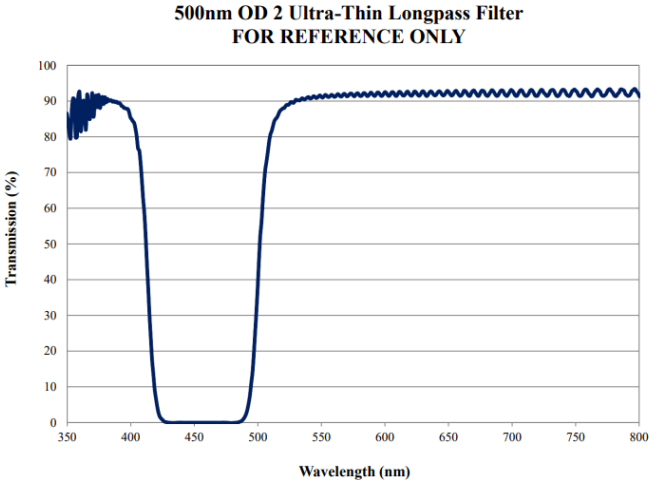

Figure 9 500 nm longpass filter Everix

The application of fluorescence detection requires a very high optical density level because of the scale of detection. Although the image in Fig. 10 does show an OD level of 2, that will not be the final OD level in the design [6]. The thickness of Everix filter is far thinner than any other filter on the market [6]. Considering most filters have a thickness greater than 1 mm, Everix filters are on the scale of a few hundred microns which allows them to be very flexible and bendable for our application. The dimensions of a long pass filter for comparison can be seen in Fig. 9.

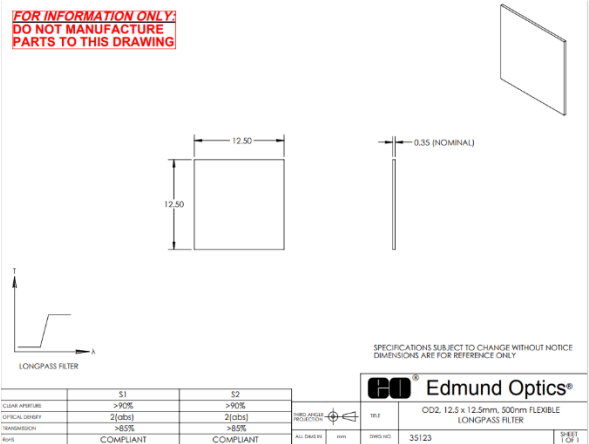

Figure 10 PDF drawing of 500 nm longpass filter from Everix

**3.2.11.1.2.1 Types of longpass filter specifications:**

**Everix-Longpass filter-** A thin film filter that can be curved to allow a high transmittance percentage for a wide range of applications

**Specifications-**

- Cut on wavelength: 500 nm
- Cut on tolerance: +- 3%
- Transmission: >85%
- Optical density: 2.0(Average)
- Dimensions: 3mm-12.5 mm
- Dimensional tolerance: +-0.1
- Type: Flexible filter
- Thickness: 100-300 um

**TechSpec high performance Longpass filter-** Used in high spectral performance, these filters allow for great blocking in the rejection region

**Specifications-**

- Cut on wavelength: 500nm
- Cut on tolerance: +- 1%
- Transmission: >91%
- Optical density: 4.0(Average)
- Dimensions: 3mm-12.5 mm
- Dimensional tolerance: +-0.1
- Type: Thick filter(coated)
- Thickness: 2mm

## Types of bandpass filters specifications:

**TechSpec hard coated 25nm bandpass filter-** used in microscopy applications with deep blocking capabilities

### Specifications-

- Wavelength range: 512.5-537.5 nm  
Cut on tolerance: +- 1%  
Transmission: >90%  
Optical density: 4.0(Average)  
Dimensions: 3mm-12.5 mm  
Dimensional tolerance: +-0.1  
Type: Thick filter(coated)  
Thickness: 3.5mm

### 3.2.11.2 LED Specifications and Beam Angle

The LED we have chosen is a Thorlabs 465E LED which has a central wavelength of 465 nm [7]. Comparing the theoretical normalized intensity distribution to the lab tested distribution we can see a shift in the lab test by about 9 nm. This shift in the spectrum will not affect the excitation of the fluorescein as there is a broad range for the excitation to occur.

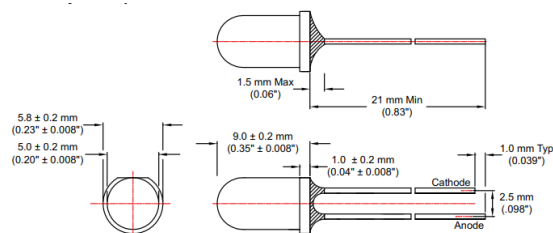

Figure 11 specification of Thorlabs 465E LED

**LED465E LED** – Emits blue light centered about 365 nm

### Specifications:

- Power dissipation: 200 mW
- Reverse Voltage: 5 V
- DC forward current: 50 mA
- Center wavelength: 465 nm +- 10 nm
- FWHM: 25 nm
- Half viewing angle: 8 degrees

The theoretical intensity distribution has a central wavelength at 465E with a FWHM of about 25 nm [7]. The LED465E intensity can be seen in Fig. 13. The LED intensity has



very little overlap into the 500 nm range, due to the high OD of the filter we will be using, this shouldn't make any difference in the fluorescein detection.

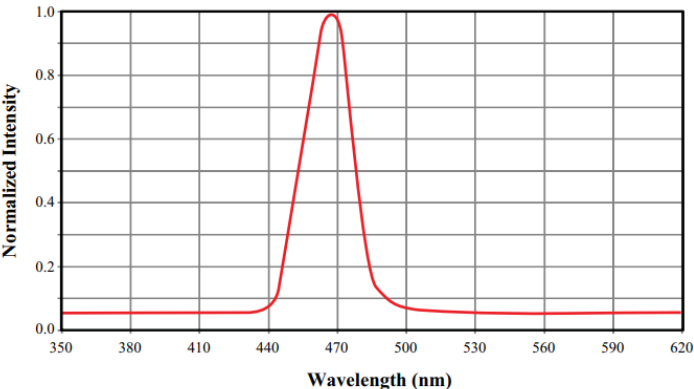

Figure 12 theoretical intensity distribution of Thorlabs 465E LED

One of the most important parameters of the LED in the new optical design is the beam profile and angle of the LED. The beam angle will decide how close the LED needs to be to the sample to allow both the correct amount of emission and the proper detection.

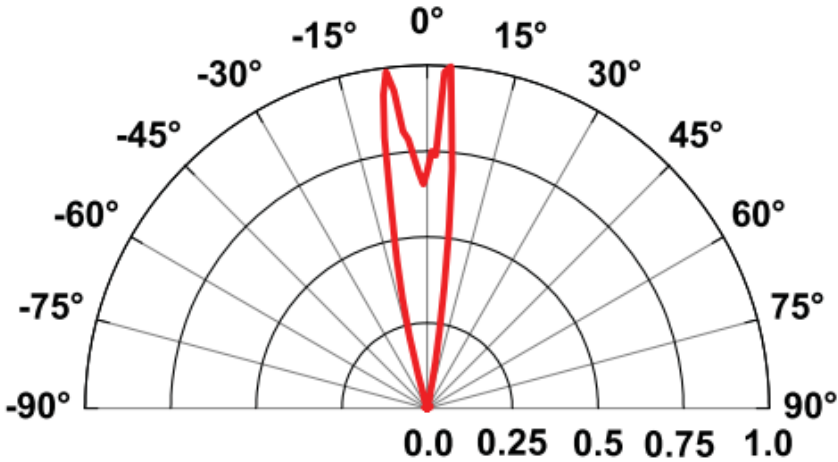

Figure 13 radial intensity distribution of Thorlabs 465E LED

The radial intensity of the LED is about 30 degrees. Changing the distance from the sample will change how much of the sample is excited by the LED

$$(6) \quad d = (\Theta/2) * \tan(\alpha/2)$$

Figure 14 Distance between LED and sample based on angle

The value of d indicated the distance from the LED to the sample, omega is the diameter of the amount we want to be shown on the sample and alpha is the beam angle profile.

The sample size will be a small glass vial with a diameter of 0.574 inches and a height of 1.714 inches including the neck of the bottle.

Using the beam angle of 30 degrees and a spot diameter of 1.25 inches starting from the bottom of the vial this will yield a distance of 4.25 mm from the vial placed equally at 0.5 inches from the bottom of the vial.

**Thor labs LED405E** – Emits a wavelength centered around 405 nm with a normalized intensity

**Specifications:**

- Power dissipation: 120 mW
- Reverse Voltage: 5 V
- DC forward current: 30 mA
- Center wavelength: 405 nm +- 10 nm
- FWHM: 15 nm
- Half viewing angle: 5 degrees

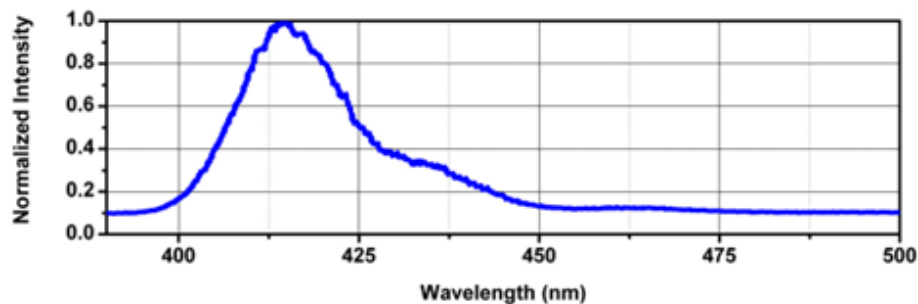

*Figure 15 Normalized intensity of Thorlabs 405E LED*

The normalized intensity of the 405E Led is very wide which would result in more light leaking into the detector at non normal angles. UV LEDs tend to have a broad range compared to LEDs.

**Thor labs LED405L** – Emits a wavelength centered around 405 nm with a broad wavelength range skewed towards the right

**Specifications:**

- Reverse Voltage: 5 V
- DC forward current: 30 mA

- Center wavelength: 405 nm +/- 10 nm
- FWHM: 20 nm
- Half viewing angle: 17 degrees

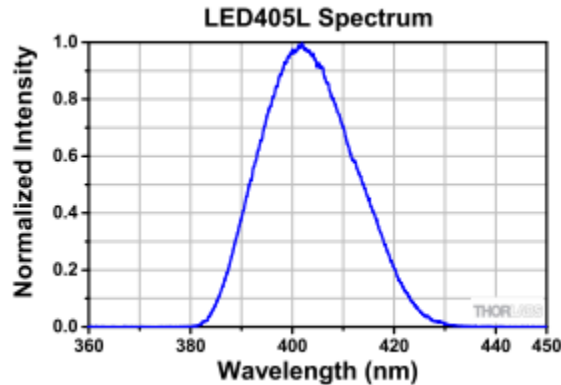

Figure 16 LED 405L normalized intensity distribution

The distribution of the 405L LED is much narrower than the 405E LED. This type of LED would not leak into the spectrum of the fluorescence and would give a much better limit of detection and signal to noise ratio.

### 3.2.11.3 Lambertian LED pattern

As light exits the surface of an LED one of the light distributions is called a Lambertian pattern. The radial intensity coming from the surface is shown by Lambert's cosine law. This allows the source to be the same brightness at any viewing angle. The power coming from the emitter is dependent on cosine since the area of the LED surface also depends on cosine.

$$B(\theta, \phi) = B_0 \cos \theta$$

Figure 17 Angular radiance equation

Because the LED emits an isotropic pattern, the surface of the LED must be in a dome shape. There are three different types of dome shapes of emitters.

- Planar
- Hemispherical
- Parabolic

The LED used here is a parabolic shape. The light intensity of the LED decreases as the angle increases beyond the normal light axis of the LED.

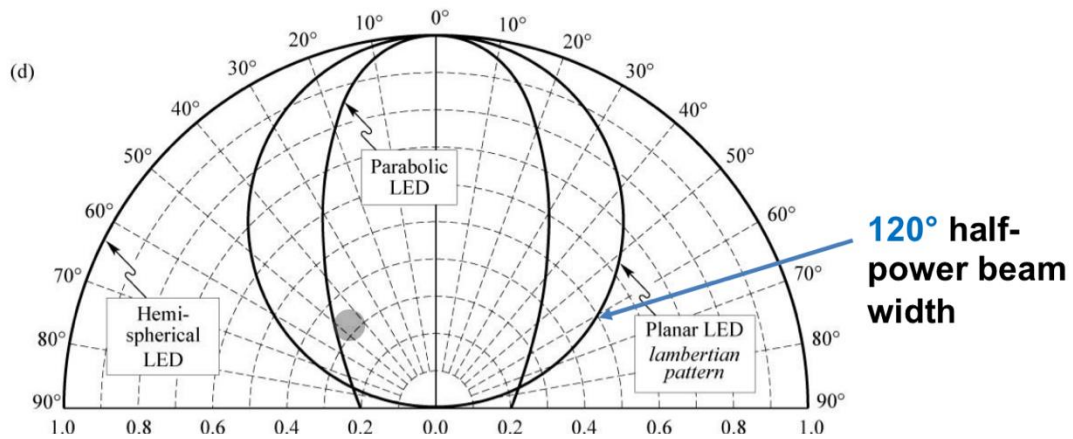

Figure 18 LED angular intensity patterns

Because the LED is going to be close to the sample, the radial light intensity is taken into account but is minimized due to how close the emitter is to the sample.

**3.2.11.4 Edge Emitting LED**

Another type of LED is edge emitting. These LEDs have a more complex pattern of the dome surface LEDs, but they reduce the need to fully take into account the z direction of the LED because the surface is only emitting in a 2D pattern.

$$B(\theta, \varphi) = \frac{1}{\frac{\sin^2 \varphi}{B_0 \cos^T \theta} + \frac{\cos^2 \varphi}{B_0 \cos^L \theta}}$$

Figure 19 Radiance equation for dome surface pattern of LEDs

The pattern is still of a Lambertian type with a 120-degree half power beam width. Edge emitting LEDs are beneficial in this application because if the parallel pattern to the sample allowing the calculations to be used without the need for the z direction.

**3.2.11.5 Plano-convex Lens Specifications**

The light collected by the lens in our optical system must be collimated so that the incident light is as close to normal angle of incidence on the optical filters. A plano-convex lens allows for better collimation of light compared to bi-convex lenses which enable better conversion of light coming from a source. Based on focal length calculations in the optical design section, the optimal focal length for our optical design is a focal length of ~3 mm.

We need a very small focal length as well as a small thickness so that we can meet our design constraints of having device size of  $85 \times 45 \times 20 \text{mm}^3$ . We also want a small f-number so that we can collect as much fluorescence light from the fluorophore concentration as well as have a small focal length. Having a lens with a large f-number means that the diameter of the lens should be close to equal to or larger than the focal length of the lens.

**Types of Lens specifications:**

**Uncoated, Plano-Convex Lens 6.0mm Dia. x 6.0mm FL** – The short focal length allows the lens to be built into a compact device.

**Specifications:**

- Diameter: 6.0 mm
- Edge thickness: 1.42 mm
- Center Thickness: 2.5 mm
- Coating: Uncoated
- Numerical Aperture: 0.50
- Focal length tolerance: +-1%

**Micro Plano-Convex lens 6mm FL** – The short focal length allows the lens to be built into a compact device.

**Specifications:**

- Diameter: 3 mm
- Edge thickness: 1.41 mm
- Center Thickness: 1.8 mm
- Coating: 425-625 nm
- Numerical Aperture: 0.25
- Focal length tolerance: +-1%

**3.2.12 Considerations for Prototype Lens Holder**

Type of Optic Holder	C-Mount Thin	Inner Single Mount	S-Mount Thin
Optic Diameter	6 mm	6 mm	6 mm
Optic Thickness Max	3 mm	4 mm	3 mm
Optic Thickness Min	1 mm	1 mm	1 mm

Holder Diameter	Outer	30 mm	NA	16 mm
Total Holder Length		9.6 mm	9 mm	8.6 mm
Price		\$44.00	\$28.00 on sale \$16	\$29.75

*Table 5 Consideration for Prototype Lens Holder Table*

The plano-convex lens that will be used in our device will have a diameter of 3 mm. Due to the small diameter and small size of the plano-convex lens there are only a small number of companies which provide fixed optic holders at this size. In constructing the plano-convex lens holder part of the prototype of our device, we have two options.

**3.2.12.1 Custom Lens Holder**

One option is to use a software such as Solidworks or CAD in order to design a lens holder for a 3 mm diameter lens and then use a 3D printer to print our designed optical holder with the desired size requirements. This plan of construction would most likely include a large degree of trial and error since our team is not well versed in modeling software and using a 3D printer and this can contribute to a large amount of failed trial runs. The positives of constructing the lens holder ourselves is that we already plan on constructing an enclosure for our device using modeling software and 3D printing so we will already have to learn how to use the software making it convenient to use, and 3D printing the lens holder will cost less than buying a conventional lens holder. One negative that comes with this method of construction comes from the large amount of time that will be required to model the lens holder as well as print it especially if it takes multiple tries to construct the lens holder to the required specifications. Another negative is that it may end up costing just as much as buying a conventional lens holder if it takes many failed attempts in order to construct the correct lens holder.

**3.2.12.2 Modified Off-The-Shelf Lens Holder**

The second method of constructing a lens mount, for use in the prototype of our device, is to buy a conventional lens mount Edmund’s Optics and then cut the lens mount down to the correct size needed to be best integrated into our prototype enclosure. The positives of this method of construction come from the convenience of being able to buy a conventional lens holder, confirmation that the holder will fit the 6 mm plano-convex lens that we plan to use since it is rigorously designed to do so, and less time will be spent on construction of the lens holder. The draw back to this construction method comes from the cost of buying the lens holder from Edmund’s Optics being larger than the potential cost of the filament for constructing the housing ourselves. Due to the cost of buying the lens holder and the shipping time needed to get the holder great care must be taken so that the process of cutting the holder down to the right size needed to fit in our device is

done precisely and does not compromise the holder's ability to hold the lens. It is important to avoid the scenario where the holder is compromised so that we can avoid having to pay for another holder as well as have further testing of our prototype delayed due to the shipping time of the new holder.

### **3.2.12.3 Final Lens Holder**

After considering these two holder construction methods we have chosen to buy a conventional holder and then cut it down to the size and fit needed for our prototype device. The three lens holders being considered for use in our prototype construction are the C-Mount Thin, Inner Single Mount, and the S-Mount Thin. The specifications and pricing for each of these holders are compared in the table labeled Considerations for Lens Holder Table.

### **3.2.13 Enclosure**

To make the final product more compact and the taking of measurements simpler and easy to pack and go, the unit shall be as compact as possible. This will improve on the usability and portability of the unit, and this will enable us to stay competitive with what is already on the market (8.5x4.5x2 cm). This will be done by making the optical side of the unit as simple as possible meanwhile using the revolutionary size and abilities of the provided filters by our sponsor. This compactness will be further amplified by using the smallest components we can in our circuit. We will have the whole optics, power source and detector in a single enclosure.

There are many varied materials for 3d printing: Nylon (known as polyamide), ABS (Acrylonitrile Butadiene Styrene), Resin, PLA (Polylactic Acid), Stainless Steel, Titanium, Ceramics, PET (Polyethylene terephthalate), HIPS (High Impact Polystyrene). Yet a few are unsuitable for our purposes of building an enclosure for our product these include: Steel due to the time its limited printing size and printing time, Titanium due to its price range, ceramics due to its fragility, PET due to its weakness to UV light.

The best printing options for our product were: HIPS thanks to its good machinability, smoothness and lightweight, and its water resistance, then PLA for its ease to print, low warping, ability to print sharp corners, next is Resin for its many applications' low shrinkage and higher chemical resistance, ABS for its accessibility, mechanical durability, and produces high prototype quality, then finally Nylon for its durability low warpage and strength and flexibility ratio. To choose one further breakdown of the filament was needed: Nylon is an engineered thermoplastic direct polyamide and is the most widely recognized plastic material. It is a notable 3D printing fiber due to its adaptability, sturdiness, low contact, and erosion opposition. Nylon is likewise a well-known material utilized in assembling garments and adornments. Nylon is appropriate to utilize while making

complicated and sensitive calculations. It is principally utilized as fibers in FDM (Fused Deposition Modeling) or FFF (Fused Filament Fabrication) 3D printers. This material is modest and perceived as one of the hardest plastic materials. ABS is a thermoplastic that is ordinarily utilized as a 3D printer fiber. It is additionally a material utilized close to home or family 3D printing and is a go-to material for most 3D printers. Resin is one of the most utilized materials in 3D printing. It is utilized in advances like SLA, DLP, Multijet or CLIP advances. There are different sorts of Resins that can be utilized in 3D printing like castable Resin, tough Resin, adaptable Resins, and so forth. PLA are produced using renewable assets like sugarcane or cornstarch. It is additionally called "green plastic". It is utilized in essential and optional schools since it is protected to utilize and simple to print with. PET or Polyethylene terephthalate is additionally one of every now and again utilized plastic. This material is utilized in thermoforming processes. It can likewise be joined with varied materials like glass fiber to make designing Resins. In 3D printing, PETG is utilized. It is an altered adaptation of PET where G means "Glycol-adjusted". Subsequently, a fiber that is less weak, clearer, and simpler to use than PET is framed. Due to this researched information Our group concluded using Resin as a material of choice for our product enclosure. This is due to several types of resin and its low shrinkage and higher chemical resistance. Of course, this is our first material of choice but might change before the prototype is completed. Below are the specs for the Tough resin we will be using for our product. As shown in Figure 21.

	METRIC <sup>1</sup>		IMPERIAL <sup>1</sup>		METHOD
	Green <sup>2</sup>	Post-Cured <sup>3</sup>	Green <sup>2</sup>	Post-Cured <sup>3</sup>	
<b>Mechanical Properties</b>					
Tensile Strength	34.7 MPa	55.7 MPa	5040 psi	8080 psi	ASTM D 638-14
Young's Modulus	1.7 GPa	2.7 GPa	239 ksi	387 ksi	ASTM D 638-14
Elongation at Break	42 %	24 %	42 %	24 %	ASTM D 638-14
Flexural Strength at 5% Strain	20.8 MPa	60.6 MPa	3020 psi	8790 psi	ASTM D 790-15
Flexural Modulus	0.6 GPa	1.6 GPa	90.3 ksi	241 ksi	ASTM D 790-15
Notched IZOD	32.6 J/m	38 J/m	0.61 ft-lb/in	0.71 ft-lb/in	ASTM D 256-10
<b>Thermal Properties</b>					
Heat Deflection Temp. @ 1.8 MPa	32.8 °C	45.9 °C	91.1 °F	114.6 °F	ASTM D 648-16
Heat Deflection Temp. @ 0.45 MPa	40.4 °C	48.5 °C	104.7 °F	119.3 °F	ASTM D 648-16
Thermal Expansion (23 – 50 °C)	159.7 µm/m/°C	119.4 µm/m/°C	88.7 µm/m/°F	66.3 µm/m/°F	ASTM E 831-13

Figure 20 Tough Resin Specs Chart

## 3.3 Parts Selection Summary

### 3.3.1 Electrical Components

#### 3.3.1.1 Component Table

1	THOR labs LED645L
2	18650 Li-Ion battery
3	ESP32



4	OSRAM OPTO SEMICONDUCTORS SFH 2700; photosensor
5	LTC3318 5V power regulator
6	OLED Display
7	Battery Holder
8	LM3940 3.3V regulator
9	LTC1050 Operation Amplifier
10	USBC-0015IPX6-00
11	Fairchild FQP50N06L MOSFET
12	TP4056 Lithium Ion Charge Controller
13	DW01A Battery Protection IC
14	MCP3426 Analog to Digital Converter IC

*Table 6 Electrical Component Table*

### **3.3.1.2 Overview**

The electrical system shall consist of all the components listed in the table above, with supporting basic circuit components like SMD resistors and capacitors. The final reasoning for selecting each part will be listed below.

#### **3.3.1.2.1 PCB Selection**

The PCB is equipped with a button, a power switch, debugging pins and header pins for the LED and Photodiode connections. The passive components on the PCB (resistors and inductors) were designed using SMD components for a more efficient design size. These sections will breakdown the need and the research for each of the components needed in our circuit and why we them. A standard two layer PCB has been selected due to its simplicity in design, and cheaper manufacturing cost compared to a 4 layer board. There is not enough complexity, or highly sensitive signals in our design to require 4 layer PCB.

#### **3.3.1.2.2 Power Regulator Selections**

Our team selected the LTC3118 and LM3940 Voltage regulators to supply 5v and 3.3v power to the PCB. The LTC3118 was selected for its exceptional input and output voltage ranges, and Powerpath technology allowing the team to include a battery and charging circuit simply with proper isolation. The LM3940 was selected because it is totally basic, and an easy way to go from 5V to 3.3V with decent efficiency.

### **3.3.1.2.3 Battery Holder Selection**

For the battery holder we opted for a ROHS3 Compliant part from Digi-key part Number 36-1042-ND. We chose this battery holder because it was available, and could be mounted directly to the PCB using soldered through hole pins. This will allow for a more compact PCB Layout.

### **3.3.1.2.4 Battery Selection**

A lithium-ion 18650 cell has been chosen as the primary battery for our device. It was chosen due to its energy density, size, voltage, and availability. 18650 cells are produced by several manufacturers and always available. The amp hour capacity of the battery can be selected by the user to determine how much time they'd like to use the device between charges, and can also be swapped by the end user if it goes bad over time. This and the reasons above made it an ideal choice for the project.

### **3.3.1.2.5 USB Connector Selection**

Our team decided to use a USB C port for charging of the device for its versatility and common adoption in the industry. As well as for its reversibility making it easier for the end user to use. The specific USB connector was chosen for its power only pin out, making the pads larger and easier to solder, and its availability from the PCB board house.

### **3.3.1.2.6 Photodiode Amplifier Selection**

The LTC 1050 was an obvious choice for this purpose. Its compact design and inclusion of sample and hold capacitors built into the IC make it very simple to add into the circuit. It is specifically designed to have very low noise, low aliasing errors, all in a small footprint. The datasheet even provides an example layout for a photodiode amplifier. Due to these factors, but especially the high precision, and low noise, the LTC1050 was selected.

### **3.3.1.2.7 Battery Protection Circuit Selection**

The battery protection components: TP4056 and DW01A have been chosen for the wide adoption in the industry. The TP4056 is a very commonly used Lithium Battery charging circuit that will safely charge our battery without a lot of design headache, and the DW01A is a very simple lithium battery protection IC that will protect the battery from the usual forms of unsafe battery operation. Over-discharge, over-charge, over-current, reverse polarity, and short circuit protection will all be provided by the TP4056 and DW01A chips.

## **3.3.2 Optical Components Table**

5.0	Fluorescein sodium salt; used as a fluorescent tracer ( $\lambda_{ex} = 460nm$ ; $\lambda_{em} = 515nm$ )
-----	---

5.1	DAPI Solution (1mg/mL) cellular imaging; used as a powder fluorescent tracer
5.2	EVERIX optical longpass filter
5.3	EVERIX curved optical long pass filter
5.4	Collimating lens with <30mm focal length

Table 7 Optical components & brief descriptions

## **4 Related Standards and Realistic Design Constraints**

### **4.1 Standards**

#### **4.1.1 Fluorescence Spectroscopy Standards**

Since our device will be used for detection of Lyme disease antibodies using fluorescence detection, our device is subject to the standards designated for fluorescence spectroscopy. The standards, for fluorescent spectroscopy which will be described in this section, come from the National Institute of Standards and Technology in conjunction with the Technology Administration and the U.S. Department of Commerce.

There are two general modes of measuring fluorescence from a sample: qualitative and quantitative [8]. Our device will provide qualitative as well as quantitative measurements.

Qualitative fluorescence measurements detect the presence of particular analytes or antibodies, yielding a positive or negative answer [8]. The excitation and emission wavelengths of the detection system are usually fixed at the peak maximum of the fluorophore chosen to be detected. A positive result is indicated by the observation of a fluorescence intensity, at the peak position, that is greater than a set threshold value based on the noise level [8].

Quantitative fluorescence measurements determine the concentrations of antibodies within an unknown sample [8]. These quantities can be determined in terms of moles or moles per liter. These determinations use the following proportionality to relate fluorescent signal (S), at a given pair of excitation and emission wavelengths ( $\lambda_{ex}$ ,  $\lambda_{em}$ ) to fluorescent analyte concentration (c):  $S \propto I_0 \Omega R_d \alpha \Phi c$  where  $I_0$  is the intensity of the excitation beam,  $\Omega$  is the fraction of the fluorescence collected by the detection system,  $R_d$  is the responsivity of the detection system, and  $\alpha$ ,  $\Phi$ , and c are absorption coefficient,

fluorescence quantum yield, and concentration of fluorescent analyte respectively [8]. This linear proportionality applies to solutions with an absorbance of less than 0.05 at a path length of 1 cm [8].

One of the common factors affecting quantification measurement is the parameter differences between instruments [8]. Parameters such as wavelengths, bandwidths, and detector gain can be set with varying degrees of repeatability and accuracy depending on the instrument used. This introduces a measurement uncertainty or bias that is significant when measured values are compared between instruments [8].

A second common factor affecting quantification measurement is that of the variation in excitation beam intensity with respect to changes in wavelength or with time, due to the wavelength-dependence of the intensity of the light source and the transmittance of the excitation wavelength selector or the time-dependence of the light source intensity respectively [8]. It is advisable to monitor the excitation beam intensity and correct the measured fluorescence intensity for these fluctuations [8].

A third common factor affecting quantification measurement is the responsivity of the detection system being non-linear at some intensities [8]. This makes it important to know the linear intensity range of the detection system being used.

#### **4.1.2 Safety Standards**

Our project will use an LED light source to emit visible light within the 400-500nm wavelength range considered to be blue light. Blue light, in the range of 380-550nm wavelengths, induces photochemical damage to the retina. This blue-light retinal injury can result from viewing extremely bright light for a short duration of time or less bright light for a longer duration. Since our project will emit blue light within this wavelength range, there are certain safety standards that we must follow. These blue light LED safety standards come from the Lawrence Berkeley National Laboratory Environment, Health & Safety (LBL EHS) standards. The following are the blue light limit threshold values: time-integrated radiance, weighted by the blue-light hazard function, should not exceed 100 J/(cm<sup>2</sup>-sr) over a total viewing time of 167 minutes in a day. If the viewing duration is longer than 167 minutes, the radiance weighted by the blue-light hazard function should not exceed 10 mW/(cm<sup>2</sup>-sr). If the light source subtends an angle less than 0.011 radians, the irradiance measured at the eye, weighted by the blue-light hazard function, should not exceed 100 μW/cm<sup>2</sup> for viewing times longer than 100 seconds, and should not exceed 10 mJ/cm<sup>2</sup> for viewing times shorter than 100 seconds. If these limits are exceeded by our device, then we must provide safety control measures such as filters, screens, and eyeglasses. Alternatively, the light hazard can be altered by changing the way the device is used or by replacing the light source with a less harmful light source.

Although batteries have made some amazing progress, safety procedures must be taken. Batteries, especially lithium ions, are not totally innocuous whenever dealt with mistakenly. Knowing what to do with batteries is accordingly a significant stage towards ideal battery wellbeing. This means that other safety measures should be taken, these include but are not limited to battery storage, static discharge, insulation, as well as damaging or puncturing of the battery. This is especially the case with lithium-ion or lipo batteries which will be the primary candidates to power our components in our build. The batteries must be stored high and dry in a non-conductive box without any other metal objects to avoid short circuiting. Inspecting the battery for signs of damage, such as leaking or rising temperatures is also very important. If the cells and batteries are accurately dealt with, the danger of fire from a lithium-ion battery from a respectable manufacturer is extremely low. Most episodes including Li-ion batteries discover a main driver in the misusing or accidental maltreatment of such batteries. Potential reasons for lithium-ion battery accidents include over charging or discharging, uneven cells, unreasonable current release, short-circuits, physical noticeable damage, unnecessarily hot storage and, for a considerable length of time in a pack, poor electrical connections. 18650 batteries can supply extremely high currents, these can start a fire if you are not careful, doublecheck battery polarity before using it in the build, as well as ensure final module enclosure has protective enclosure to prevent shorts.

### **4.1.3 Electronics Housing Standards**

Industry standards for electrical enclosures exist to advance security, energize plan productivity and characterize least degrees of item execution. The National Electrical Manufacturers Association subtleties the prerequisites for safe electronic lodgings. The NEMA norms distribution 250-2003, the archive records the kinds of walled in areas just as the necessities for each. As indicated by the NEMA standard, our gadget would be type 5. Type is depicted as a fenced in area developed for indoor use, that gives security to staff against unsafe parts. Likewise, to be viewed as type 5, the fenced in area should likewise give security to the gear inside from strong unfamiliar items like soil, settling airborne residue, build up, strands, etc.

### **4.1.4 Coding Standards**

Coding norms ensure the production of consistent and functional software even when multiple programmers are working concurrently on one piece of software. Making the codebase as if it was written by one person.

While forming the code, the team will follow these guidelines:

1. The code should be neat and easy to read
2. Variable and functions will have a succinct and consistent naming format

3. Coding tasks will be simplified and broken up into easily accomplished pieces and then brought back together.
4. The code will use consistent indentation to make it easy to follow structure of the code
5. There will be consistent and frequent comments explaining what is being done

There are many benefits to adhering to coding guidelines when programming. One benefit of observing coding guidelines is increased efficiency. Most software engineers spend an enormous amount of time attempting cleaning up poor coding practices that could be completely avoided by carrying out the above principles, and a ton of those preventable bugs will likely be introduced by bad practices. Coding principles limit the complexity of each line of code, making it easier to write, read and maintain. This likewise makes the code cost effective on the grounds that it enables the designer to reuse code because it is generally simpler, and more portable when written with proper practices.

#### **4.1.4 ISO/TC 172 – Optics and Photonics**

The International Organization for Standardization (ISO) additionally has an objective for guidelines in the field of optics and photonics. The extent of the ISO is to build up a normalization of wording, necessities, interfaces and explicit test strategies in the domain of optics and photonics. The guidelines incorporate total frameworks, ophthalmic optics, gadgets, instruments, optical and photonic parts, just as materials. According to them "Optics and photonics are utilized in the significance of age, taking care of and identification of optical radiation including signal handling".

### ***4.2 Realistic Design Constraints***

#### ***4.2.1 Economic and Time Constraints***

With a financial sponsorship budget from Everix of \$1,500, our plan is to have the cost a singular prototype of our Lyme Disease antibody detection device does not exceed a value of \$750. Although this pricing may decrease the quality of the LED, photodiode, operational amplifier, and other components, the portability and lower cost of our device will allow our device to compete with other typically low portability fluorescence sensing devices. Most of the components that make up our device are currently accessible on the market and can be easily purchased and received. This comes with the caveat of the current lack of availability of electronics in the current post COVID market because electronics and semiconductor supply chain issues resulting from the impact of COVID-19 in countries relied upon heavily for the production of electronics. Our device however will use thin optical filters provided and custom made by our sponsor Everix. These

custom thin optical filters that Everix is providing us for use in our device are expensive and by being custom made are not as easily accessible as the other components used in our device.

With the portability of our Lyme Disease antibody detection device, the user would save on the typical time cost of travel time needed to take a sample to laboratory from the place the sample was extracted from. As of yet there is no current estimate of the cost saved by using our device instead of travel from the sample extraction point to the laboratory. The value of the portability savings in the cost of travel will vary across users depending on the application use case.

The time schedule for the design and creation of a demonstratable version of our device begins in the Senior Design 1 course and ends at the end of the Senior Design 2 course. A demonstratable version of our device must be completed by April 2022. This gives us approximately 8 months from the end of August 2021 to design, test, and redesign our device before demonstrating the completed product to our sponsor Everix and our advisors at the end of the Senior Design 2 course in April 2022. By the end of this time period the testing, design, prototyping, and implementation of this device must be completed, and the device must be fully functional in order to fulfill the engineering requirements. Our device must be able to accurately discern between various concentrations of fluorophores within a solution. Along with accurate detection of concentrations of fluorophores the device shall provide feedback as to the concentration of anti-bodies represented by said concentration of fluorophores detected in the solution. To ensure that these goals are met, a project timeline is included in a table in the Milestone section of this document and that table lists each task that is chronologically needed to be completed by each date.

#### ***4.2.2 Manufacturability and Sustainability Constraints***

Manufacturability is the art of designing a device or product with the ability to be easily constructed or mass-produced. The manufacturing functions that should be kept in mind are fabrication, assembly, testing, acquisition, shipping, and repair. Our goal with this project is to design a product that apart from the in-house design of the thin optical filters by our sponsor Everix, will take at most three hours to wire and piece together parts from third-party manufacturers.

In the prototype construction section of this document, the photodiode, LED, plano-convex lens, and filter housing designs will be detailed as well as an explanation of how they can be modeled. The plano-convex lens, sample container slide, electrical circuitry, and electrical components will be bought from a few different companies. Buying components made by these companies is useful to us because these companies have

already undergone the process of designing these components with manufacturability in mind. Several benefits come from purchasing these components from these companies including reduced costs, decreased lead times, higher quality, and increased reliability. The downsides to purchasing components from these companies, instead of building them ourselves, is the time that it takes for the parts to be shipped and the shipping cost.

To improve the sustainability of our device, the subsystems of our device must be built from components that are common and can be easily ordered. To minimize damage to the electrical circuit from the outside environment, an electrical enclosure will be constructed, and 3D printed. To reduce possible damage to optical components and the fluorescent solution container, an enclosure will be designed, and 3D printed in such a way that the optical components have minimal vibrational movement and no damage done by the environment to the optical components.

#### ***4.2.3 Ethical, Health and Safety Constraints***

It is very important for our device to meet Environmental, Health, and Safety standards. Since our device will be used in detection of Lyme Disease antibodies from potential Lyme Disease patients there are many requirements our device will have to meet. The major topics which will be discussed include the health impact of blue LED light and the heat dissipation to prevent potential health hazards.

Blue LED light in the range of 380-550nm wavelengths is capable of inducing photochemical damage to the retina. The LED that our device uses as an excitation light source has a measured wavelength of 474nm which lies within the range of wavelengths of light which are known to be damaging to the retina. It is important that our LED have emission radiance less than 10 mW/(cm<sup>2</sup>-sr). Our device will have an LED which produces excitation light emission at a low enough intensity to have radiance lower than the limit outlined in the blue light LED Safety Standards section of this document. Our device will have an enclosure designed to protect the optical components and sample container from environmental hazards as well as to prevent the user from exposing themselves to the blue LED light emission over sufficiently long periods of time (167 minutes). If the duration of exposure to our LED were to last long enough or LED light radiance exceed the threshold outlined in the Safety Standards section than, we must require that the user of our device use required safe eye wear which would prevent retinal damage from our LED light emissions in the event that the emissions prove hazardous.

The battery that we plan on using is a lithium-ion battery which has been known to cause thermal damage due to high heat or even start a fire when mishandled since these batteries can supply extremely high currents into the circuit. This is a potential health hazard that we will mitigate through the battery storage in a dry nonconductive material,



taking measures to prevent static discharge, insulation, and encasing the battery to prevent the external environment from damaging or puncturing the battery. Since our device will be small enough to carry around in one hand, heat dissipation is something that we will need to be aware of when designing our Lyme Disease antibody detection device. With this use case in mind, it is important that our device stay at a cool temperature similar to that of a phone would have.

#	Requirement	Reason
1	Low power blue LED	The blue LED with a wavelength peak of 474 nm will need to have a light emission radiance below 10 mW/(cm <sup>2</sup> -sr) to prevent possible damage to the users' retinas
2	Controlled heat dissipation	Device cannot be allowed to overheat since the user will be carrying the device. Keep temperature under 90 degrees Fahrenheit

Table 8 Safety Requirements Table

**4.2.4 Ethical, Political, and Social Constraints**

Ethical, social, and political issues must be considered when designing a portable Lyme Disease antibody detection device such as ours. A main concern which will be discussed is how our device will enable detection of Lyme Disease antibodies outside of the laboratory environment and at a lower cost compared to current tabletop fluorometer devices. Political issues such as obtaining FDA approval through clinical trials and healthcare companies providing coverage of our device.

The portability of our fluorescence sensing device, which will be used to detect Lyme Disease antibodies, will enable individuals to be tested for Lyme Disease without having to wait for a blood sample to travel back to a laboratory elsewhere to be told the results of whether the patient has Lyme Disease antibodies or not. Our device could potentially speed up the process of a patient dealing with Lyme Disease and taking the correct steps to become healthy again, because our devices portability has the potential to diagnose a patient with Lyme Disease earlier than would normally be possible with current tabletop in laboratory measurement systems. For our product to be FDA approved and be sold in the market our device must be test through a large number of clinical trials. For this reason, we are not attempting to bring our device to market within the timeline outlined for this project. Instead, we plan to test our device out using various quantities of fluorophores, which would normally be attached to antibodies, in order to prove that our device can feasibly detect and distinguish between quantities of fluorophores within a solution and therefore feasibly show that with the proper continual tests our device could detect Lyme Disease antibodies. Through detection of various concentrations of fluorophores within solutions we will determine our device's limit of detection. It is

important that our devices limit of detection be at a small enough concentration to compete with other more costly benchtop fluorescence sensing systems. In order for our device to effectively join the market we may have to comply new standards created for portable fluorescence sensing devices designed to detect Lyme Disease antibodies.

#### **4.2.5 General Constraints**

Since our project is still in the early stages, we have not come across many constraints. One major constraint that has come to our attention is the filtering of the light incoming to the photodetector so that only the fluorescent light emitted by the biomarker is picked up by the detector. It is important that LED light intended to excite the markers does not pass through the optical filter and become processed into the fluorescent light believed to be detected by the device. This means that it is important for us to filter out as much light as possible outside of the fluorescent wavelength we intend to measure. It's also crucial that we are able to adequately excite the markers so that the sensor can get a low noise signal. Otherwise, there will not be enough signal to adequately classify the fluorescent response. Additional constraints may come from implementation of stretch goals such as transmission of data via Wi-Fi or bending the optical filters instead of using lenses.

# 5 Project Hardware and Software Design Details

## 5.1 Initial Design Architecture and Related Diagrams

### 5.1.1 Integrated System Diagram

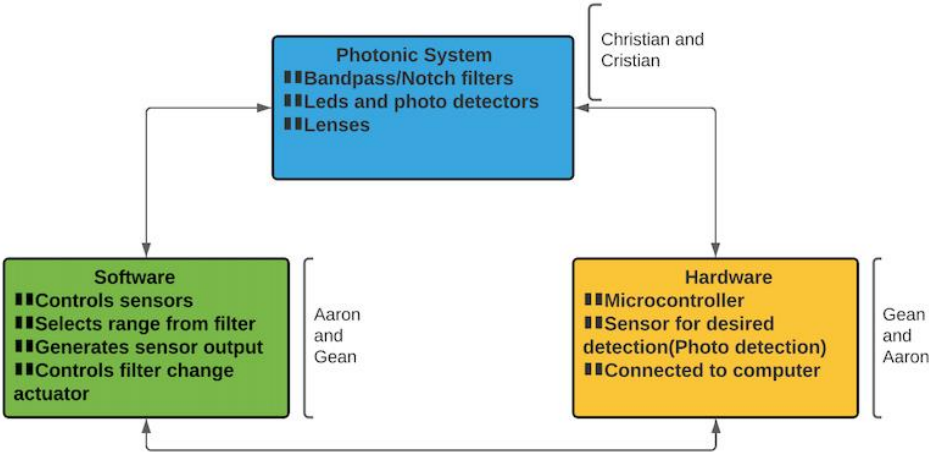

Figure 21 Initial Integrated System Diagram

### 5.1.2 Data Path Diagram

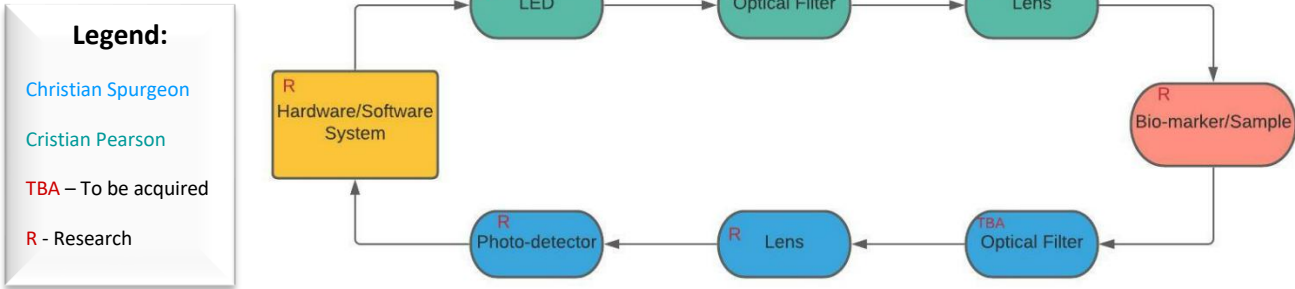

Figure 22 Initial Data Path Diagram with Legend

### 5.1.3 Optical System Diagram

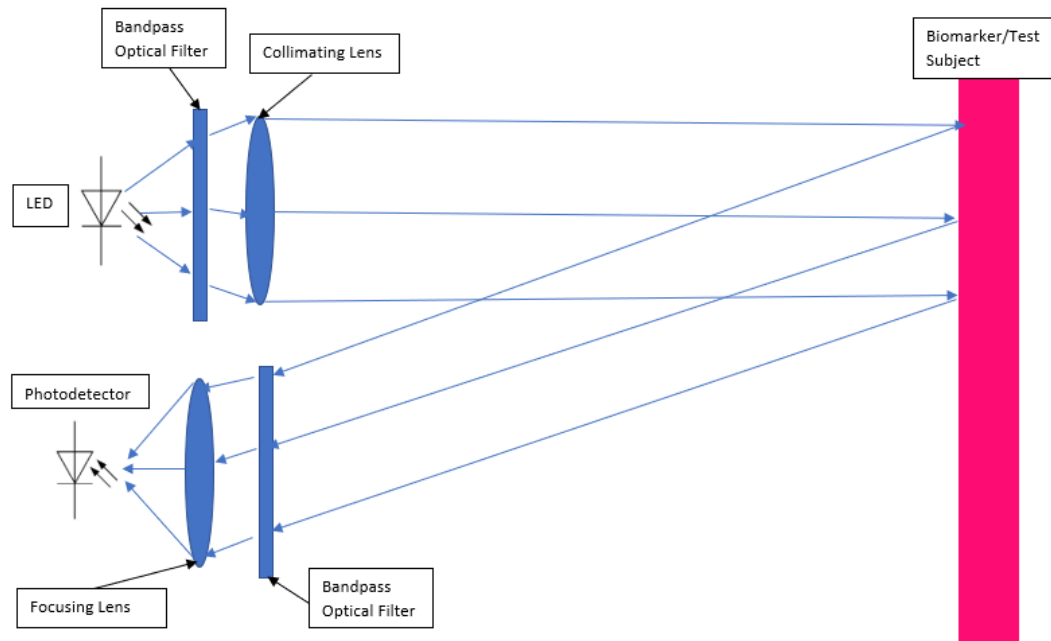

Figure 23 Initial Optical Diagram

#### 5.1.3.1 Previous Excitation Optical Sub System

The first optical sub system which we will discuss is designed around exciting fluorophores within an unknown sample to obtain concentration of antibodies for a disease. We have recently changed our optical design for the excitation optical sub system after talking with our sponsors Everix. We have since then decided to no longer have a lens or optical filter to collimate and filter the excitation light of our system. We have made this design decision to simplify our devices' design as well as allow the device to be more compact and at a smaller size more in line with what our sponsors want in our device. The following components described within this section detail an older design of our device before our recent changes in design. The components within this sub system consist of a lens, a thin optical filter, and an LED. We will measure the limit of detection of our device with the use of fluorescein in a variety of sample concentrations.

The peak excitation wavelength of fluorescein is at 460 nm. This means that we must choose an LED with an emission spectrum with a peak intensity within plus or minus 10 nm from 460 nm.

Our device will be supported by a thin optical bandpass filter supplied by our sponsor company Everix. The optical filters designed by Everix are at a very thin thickness which

supports our goal of designing our device to be both compact and portable. Everix's thin optical filter has refractive index of  $\sim 1.5$  and has a small enough thickness that the deflection or refraction of light through the optical filter is considered negligible when compared to our overall system design. This thin optical bandpass filter enables our device to filter out the larger spectrum of light, emitted from the LED and allow only light within 5 nm of the excitation wavelength of 460 nm to pass through to the collimating lens.

A lens will be used within this subsystem to collimate the excitation light emission from the LED and subsequent optical filter. In order for the light output to be collimated, the lens must ideally be placed at a distance of a focal length away from the light source which in our case is a blue light LED.

Properties	LED	Collimating Lens	General Optical Bandpass filter	Everix Optical Bandpass filter
Refractive Index	NA	1.45-155	-	$\sim 1.5$
Focal Length	NA	< 30mm	NA	NA
Thickness	NA	1-5mm	1-3mm	0.01-0.015mm
Spectral Bandwidth	Peak emission wavelength 455-470nm	NA	340-12,000nm	340-12,000nm

Table 9 Components in previous excitation optical sub system & properties

**5.1.3.2 Previous Excitation Optical Sub System Paraxial Ray Trace**

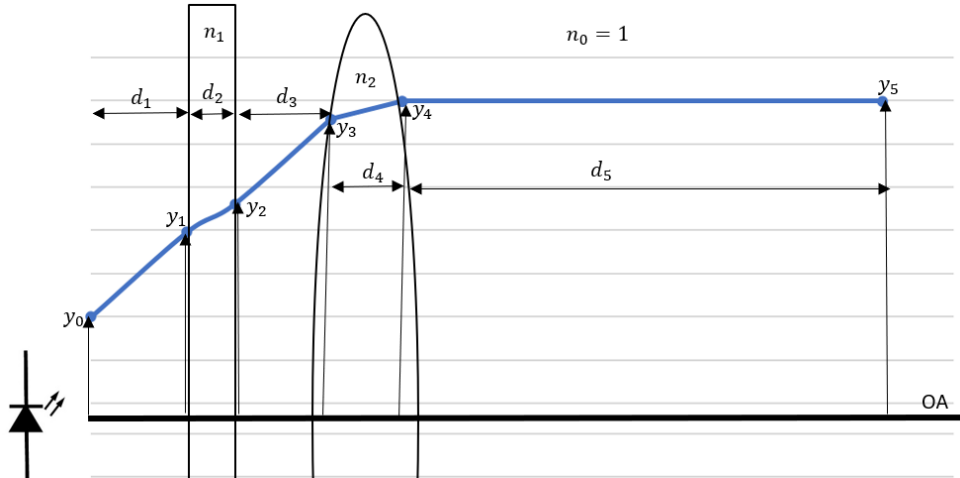

Figure 24 Previous Excitation Optical Sub System Paraxial Ray Trace

Previous Paraxial Ray Trace Matrices:

$$\begin{bmatrix} y_5 \\ n_5 u_5 \end{bmatrix} = \begin{bmatrix} 1 & d_5/n_0 \\ 0 & 1 \end{bmatrix} \begin{bmatrix} 1 & 0 \\ -n_0/f & 1 \end{bmatrix} \begin{bmatrix} 1 & d_4/n_2 \\ 0 & 1 \end{bmatrix} \begin{bmatrix} 1 & 0 \\ -n_2/f & 1 \end{bmatrix} \begin{bmatrix} 1 & d_3/n_0 \\ 0 & 1 \end{bmatrix} \begin{bmatrix} 1 & d_2/n_1 \\ 0 & 1 \end{bmatrix} \begin{bmatrix} 1 & d_1/n_0 \\ 0 & 1 \end{bmatrix} \begin{bmatrix} y_0 \\ n_0 u_0 \end{bmatrix}$$

*Figure 25 Initial Excitation Optical Subsystem Paraxial Ray Trace Matrices*

The matrices in figure 26 use the Paraxial Refraction and Translation equations to trace rays coming from the input of this subsystem to the output of this optical sub system. Figure 25 shows a paraxial ray trace from the light input from the LED at  $y_0$  to the sample at a certain distance away. The paraxial ray trace distances  $d_1, d_2, d_3, d_4,$  and  $d_5$  in figure 40 and 41 represent the distance from the LED source to the optical filter, the thickness of the optical filter, the distance from the optical filter to the collimating lens, the thickness of the collimating lens, and the distance from the collimating lens to the sample solution respectively. The paraxial ray trace heights, with respect to the optical axis,  $y_0, y_1, y_2, y_3, y_4,$  and  $y_5$  in figure 25 represent height of the ray emitted from the LED, the height of the ray at air to optical filter interface, the height of the ray at the optical filter to air interface, the height of the ray at the air to collimating lens interface, the ray height at the collimating lens to air interface, and the height of the collimated light once it reaches the sample solution. The first optical element in figure 25's diagram, with a refractive index  $n_1$ , is the optical filter. In the paraxial ray trace the optical filter is approximated to be a change in translational medium since an optical filter has very little curvature and therefore a very large focal length which can be approximated to be nearly infinite when we are dealing with a scale of tens of millimeters. The second optical component in figure 25's ray trace is the collimating lens. This lens as seen in figure 25 has a refractive index denoted by  $n_2$ . The ray trace through the lens is performed with two matrices associated with paraxial refraction and one matrix associated with paraxial translation of the ray across the lens medium. In order for a light coming from a light source to achieve collimation, a lens must be placed at a distance, approximately equal to the focal length of the lens, away from the light source. This means that the summation of distances and thicknesses  $d_1 + d_2 + d_3 \approx f$  from the source to the collimating lens must be approximately equal to the focal length of the lens used in order for our device to achieve collimation of output excitation light.

### 5.1.4 Electrical Diagram

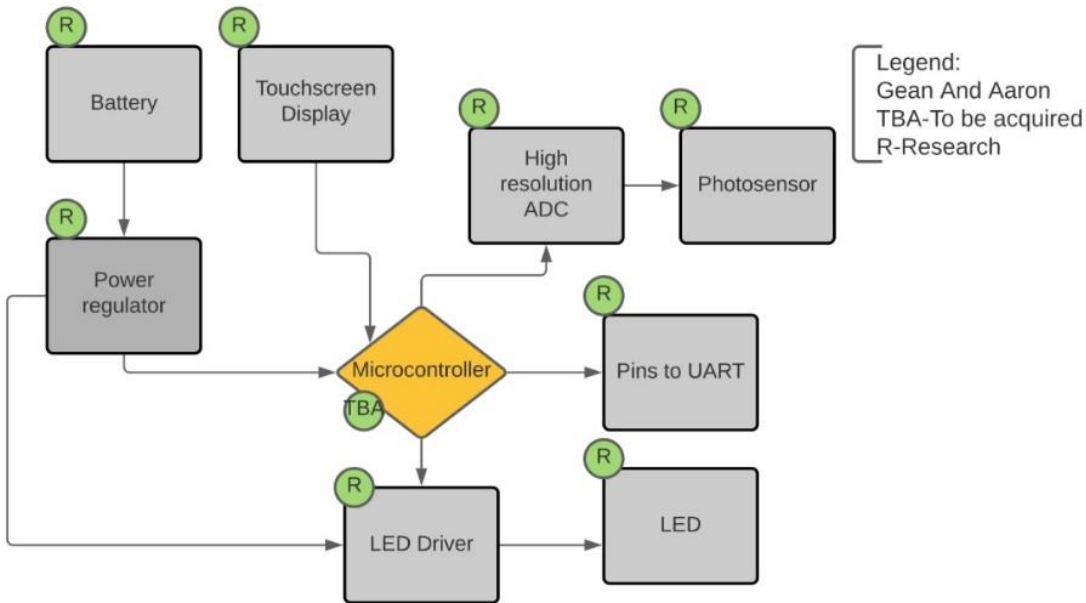

Figure 26 Initial Electrical Diagram

### 5.1.5 Software Flow Diagram

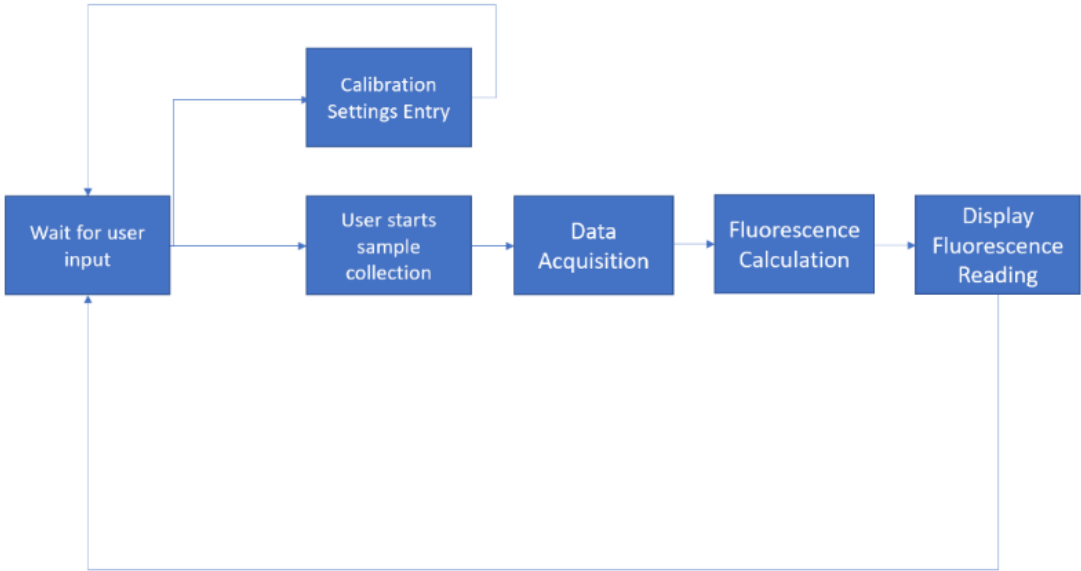

Figure 27 Initial Software Flow Diagram

## 5.2 Electrical Subsystem

The PCB was designed by Aaron and Gean. It includes all of the parts in the component selection summary, and the Schematic and board layout will be shown below. The team decided to use EasyEDA to design the schematic and PCB layout. It was an easy to use, free, and online schematic editor that allowed us to collaborate on the design without the hassle of sending files back and forth.

### 5.2.1 Electrical Schematic Diagram

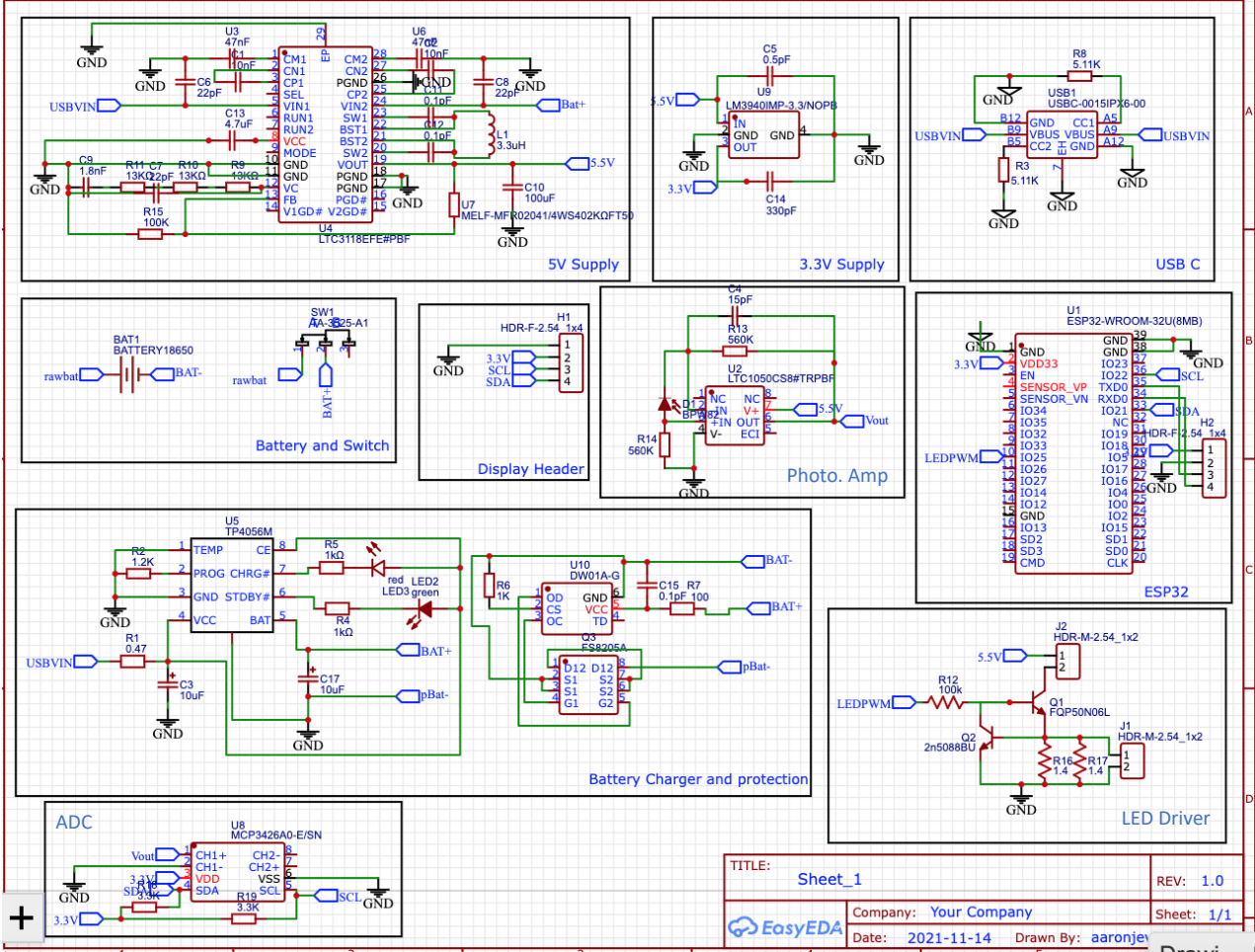

Figure 28 Final Project Schematic

### 5.2.2 Electrical Subsystems



### **5.2.2.1 Power Regulation**

Looking at the schematic diagram, the power sections include the 5V supply, and the 3.3V supply sections. Each box respectively contains a fairly standard implementation of the design shown in the datasheet for these two parts. Together, they will generate the 5V and 3.3V power rails needed to make the device operate.

### **5.2.2.2 USB C Connection**

The USB – C connection contains a standard power only 5V usb implementation. With resistors on the control lines to enable power output of the power supply. This section is where 5v USBVIN enters the design for use by the power regulators.'

### **5.2.2.3 Battery and Switch**

The Battery and Switch section includes the battery, and shows the switch connected the battery negative lead. This switch will allow the user to turn off the device by electrically isolating the battery from the circuit.

### **5.2.2.4 Display Header**

The display header is simply a standard 2.54 MM header for interfacing the Display PCB. It will be populated with female header pins, so the power is not on an exposed pin that could be shorted and will allow the display to connect to the main pcb.

### **5.2.2.5 ESP32**

The ESP 32 Section shows the microcontroller, with its power and ground connection, and connection of its GPIO to various other sections including the display and ADC, as well as the LED Driver.

### **5.2.2.6 Photodiode Amplifier**

The photodiode amplifier section was designed based on the reference design from the LTC1050 datasheet for photodiode amplification specifically and will server to amplify photocurrent into a measurable voltage for ADC.

### **5.2.2.7 Battery Charger and Protection**

The battery charger and protection circuit implements a common design for the TP4056 and DW01 combining both of their reference design. The DW01 connects to the battery and two FETs are put in series with the battery ground, giving the DW01 the ability to

disconnect the battery from the circuit in unsafe conditions. The TP4056 circuit connects to the battery through the DW01 and also includes indicator LEDs to show charge state of the battery when it is charging. The temp sensing capabilities of the TP4056 will not be used because our battery does not contain an internal thermocouple.

### 5.2.2.8 LED Driver

The LED Driver section contains a simple implementation of a constant current supply. The current is set using a resistor, and extra pads have been added to the board to allow adjustment of the LED drive current. It should be noted that Q1 is a MOSFET, but the correct symbol did not exist on easy EDA.

### 5.2.2.8.1 ADC

The ADC section includes necessary connections for the ADC. Connecting it to the output of the photodiode amplifier, as well as power, and SDA, SCL for I2C communication with microcontroller.

### 5.2.3 BOM

The BOM is shown in the figure below. Special care was made by the team to source parts that had high quantities in stock, and some orders have been already placed for the the components we cannot do without or easily substitute.

ID	Name	Designator	Footprint	Quantity	Manufacture	Manufacture Supplier	Supplier Part	Price	JLPCB Part Class	Cost	Total
1	BATTERY186	BAT1	BATTERY_18	1		Digkey	1597-114090053-ND	1.49		1.49	132.497
2	10nF	C1,C2	CAP-SMD_L4	2	CDR02BX103	VISHAY/威世	LCSC C2312066	0.227		0.454	
3	10uF	C3	CAP-SMD_L6	1	TAJ1C106K02AVX	AVX	LCSC C7210	0.263	Extended Part	0.263	
4	15pF	C4	C0402	1	CC0402JRN1P	YAGEO	LCSC C106997	0.001	Extended Part	0.001	
5	0.5pF	C5	C0402	1	C1005NP050	Darfon Elec	LCSC C147327	0.008	Extended Part	0.008	
6	22pF	C6,C7,C8	CAP-SMD_L1	3	100A220FT1	ATC	LCSC C609562	8.264		24.792	
7	1.8nF	C9	C0402	1	CL05B182KB	SAMSUNG	LCSC C5296	0.003	Extended Part	0.003	
8	100uF	C10	C0603	1		Digkey	GRM32ER60J107ME20L	0.8		0.8	
9	0.1pF	C11,C12	CAP-SMD_L1	2	100A0R1B1T1	ATC	LCSC C609622	5.274		10.548	
10	4.7uF	C13	C0603	1			CC1210KXX7R988475	0.5		0.5	
11	330pF	C14	C0402	1	CD402K7R33	Shenzhen Ey	LCSC C115681	0.003	Extended Part	0.003	
12	0.1pF	C15	C0402	1	RF15NOR1B1	Walsin Tech	LCSC C384683	0.007	Extended Part	0.007	
13	10uF	C16	C0402	1	0402X106M6	Huaxin S&T	LCSC C106833	0.033	Extended Part	0.033	
14	BPW82	D1	PHOTODIODE	1	FDS015	Thorlabs		53.08		53.08	
15	3.3uH	L1	IND-SMD_L5	1	CKCS5040-3	CENKER	LCSC C354603	0.062		0.062	
16	green	LED2	LED1206-FD	1	TJ-532165W	TOGIALED	LCSC C192677	0.037	Extended Part	0.037	
17	red	LED3	LED1206-R-R	1	E6C1206URJ	EKINGLUX	LCSC C375458	0.025	Extended Part	0.025	
18	FS8205A	Q3	TSSOP-8_L4	1	FS8205A	FORTUNE	LCSC C16052	0.21	Basic Part	0.21	
19	0.47	R1	R0402	1	0402WGF47	Uniroyal Elec	LCSC C423162	0.006	Extended Part	0.006	
20	1.2K	R2	R1206	1	QR1206F1K2	Ever Ohms T	LCSC C176229	0.006	Extended Part	0.006	
21	5.11K	R3,R8	R0805	2	0805W8F51	UniOhm	LCSC C55317	0.002	Extended Part	0.004	
22	1kΩ	R4,R5	R1206	2	RT1206DRDX	YAGEO	LCSC C723617	0.029		0.058	
23	1K	R6	R0402	1	0402WGF10	UniOhm	LCSC C11702	0.001	Basic Part	0.001	
24	100	R7	R0402	1	AC0402DR-0	YAGEO	LCSC C226677	0.003	Extended Part	0.003	
25	13kΩ	R9,R10,R11	R0402	402	RS-02K133IT		LCSC undefined	0.17		0.51	
26	100K	R15	R0402	1	QR0402F100	Ever Ohms T	LCSC C176106	0.003	Extended Part	0.003	
27	560K	R13,R14	R0402	2	AC0402FR-0	YAGEO	LCSC C227139	0.003	Extended Part	0.002	
28	TA-3525-A1	SW1	SW-SMD_3P	1	TA-3525-A1	Yuanli	LCSC C514018	0.145	Extended Part	0.145	
29	ESP32-WROU1	U1	WIFIM-SMD	1	ESP32-WROU1	Espressif Sys	LCSC C529579	4.941	Extended Part	4.941	
30	LTC1050CS8U2	U2	SOIC-8_L5-0	1	LTC1050CS8I ADI	(亚德诺)	LCSC C580346	5.882	Extended Part	5.882	
31	47nF	U3,U6	CAP-SMD_L4	2	ECHJ1H473J	PANASONIC	LCSC C178430	0.477	Extended Part	0.954	
32	LTC3118FEF4U4	U4	HTSSOP-28_L	1	LTC3118FEF4	Analog Devic	LCSC C684145	22.603	Extended Part	22.603	
33	TP4056M	U5	MSOP-8_L3	1	TP4056M	TOPPOWER	LCSC C21417	0.217	Extended Part	0.217	
34	MELF-MFRO-U7	U7	RES-SMD_L3	1	MELF-MFRO	Thunder Cor	LCSC C265797	0.028	Extended Part	0.028	
35	MCP3426A0-U8	U8	SOIC-8_L4-9	1	MCP3426A0	Microchip Te	LCSC C220770	2.992	Extended Part	2.992	
36	LM3940IMP-U9	U9	SOT-223_L6	1	LM3940IMP	Texas Instru	LCSC C140319	1.269	Extended Part	1.269	
37	DW01A-G	U10	SOT-23-6_L2	1	DW01A-G	FORTUNE	LCSC C61503	0.09	Extended Part	0.09	
38	USBC-0015IF	USB1	TYPE-C-USB	1	USBC-0015IF	SHOU HAN	LCSC C783298	0.467	Extended Part	0.467	

Figure 29 BOM (bill of material)

### 5.2.4 PCB Layout

The team tried to layout the PCB to minimize size, and minimize the number of traces that had to be routed on the bottom layer to improve signal performance. The team was able to achieve an overall dimension of 107mm by 37mm. The 18650 battery holder is mounted on the back of the PCB and can be seen as the 6 large holes going through the board. The related ICs were grouped together to minimize length of traces, and capacitors were used on many critical traces.

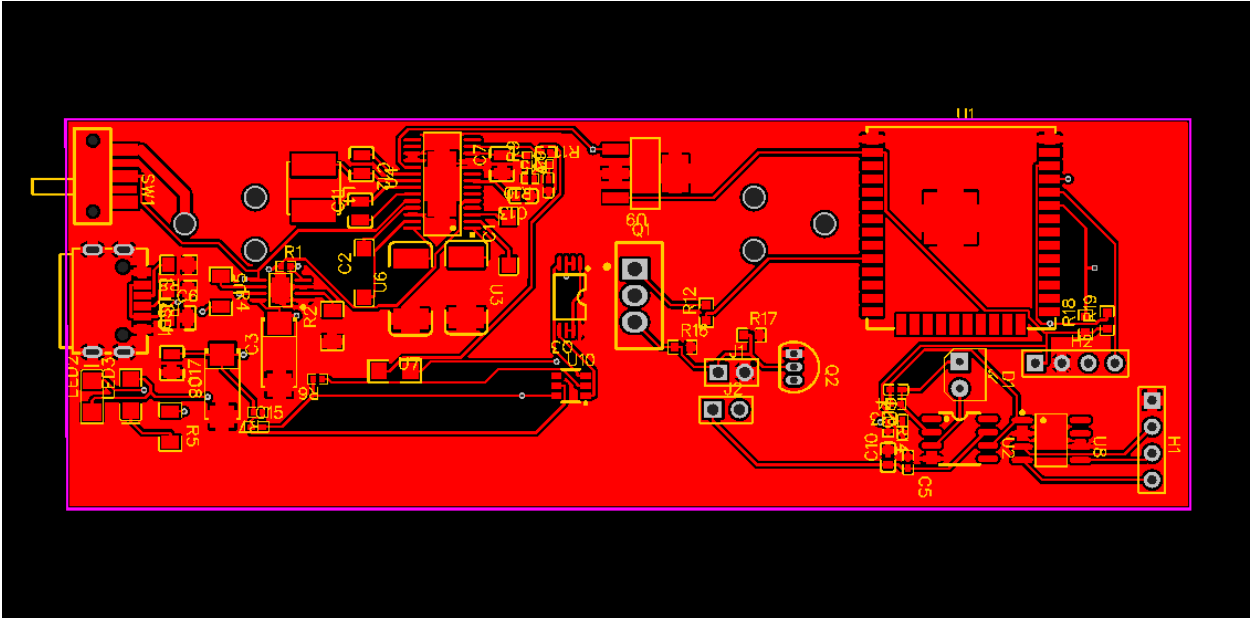

Figure 30 Printed Circuit Board design (PCB)

### 5.3 Optical Subsystem

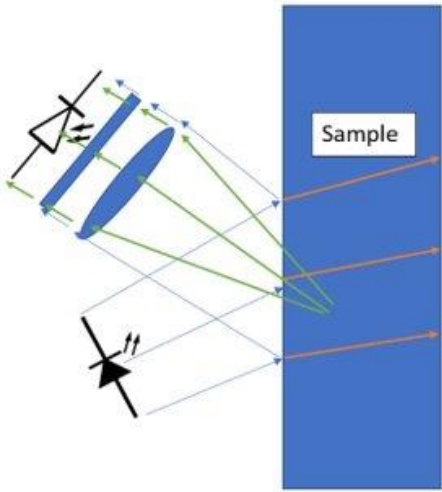

Figure 31 Fluorescence optical subsystem overall design using lens as in case 1 of our design

### **5.3.1 Fluorescence Detection Optical Sub System**

We plan to test two cases for this optical sub system. One case deals with use of a lens to collimate light onto a flat optical filter for detection of fluorescent light emission from fluorophores within the sample. Second optical system design case deals with the use of a curved optical filter in the place of the lens to collect and filter the fluorescent light emitted by the fluorophores in the sample solution. The second case will enable our device to be more compact but at the cost of a more complex design for a nonlinear optical filter. Both optical design cases use an LED to excite the fluorophores within the sample to fluoresce.

#### **5.3.1.1 Case 1: Fluorescence Detection Optical Sub System with Lens**

The first optical sub system case which we will discuss is designed around exciting fluorophores within an unknown sample to obtain concentration of antibodies for a disease by use of a focusing lens for collimation of fluorescent light onto a flat optical filter. We have decided to no longer have a lens or optical filter to collimate and filter the excitation light from the LED in our system. We have made this design decision to simplify our devices' design as well as allow the device to be more compact and at a smaller size, more in line with what our sponsors want in our device.

This optical subsystem is designed around the detection of fluorescence emission from a sample with an unknown concentration of fluorophores. The components within this sub system include a LED, an optical bandpass filter, a photodetector, and a lens. The LED is rotated at an angle with respect to sample container. An optical axis can be drawn linearly through the center of the photodiode, optical filter, collimating lens. The optical axis running through the center of these components is rotated at an equal and opposite angle to the rotation of the LED. As seen in Fig. 44 the LED, collimating lens, optical filter, and photodiode are rotated in such a way that both the reflected LED light and the fluorescent light emission will be collected by the collimating lens and then the fluorescent light will pass through to the photodiode and the reflected LED light will be cut off by the optical filter. As seen in Fig. 44 the fluorophore fluorescence emission is detected from the area where the field of view of the LED and the collimating lens overlap. The rotation of these optical components enables our optical system to achieve a close proximity to the sample while still being able to have efficient detection with a small size for our device. As shown in Fig. 44, the LED and collimating lens will be placed at equal distances from the sample container.

The optical bandpass filter used in this sub system allows only fluorescent light wavelengths to pass through to the sample and filters out all other wavelengths below a 500 nm wavelength cut off. The fluorescence emission spectrum consists of wavelengths larger than 500 nm which will be transmitted through the filter while the reflected LED light

will not be transmitted through the optical filter due to the spectrum, of the chosen LED type 465E, consisting of wavelengths lower than the 500 nm cut off of the optical filter. The cut-off wavelength of 500 nm for the optical filter was chosen due to its positioning between the wavelength spectrum of the LED and wavelength spectrum of the fluorescein fluorescence. It is important to note that blue shifting will occur when light hits the optical filter at large angles of incidence. Blue shifting is a phenomenon in optical filters where the larger the angle of incidence of the light hitting the optical filter the more that the cutoff wavelength of 500 nm will shift to smaller wavelengths. A large blue shift in our optical system would allow for the blue LED light reflected from the sample container to leak into the photodiode and registered as part of the fluorescence signal. This would be problematic and lead to mis diagnosis of antibodies within a sample concentration. In order to prevent blue shifting as much as possible, the light incident on the optical filter must be as close to normal incidence as possible. The optical bandpass filter that we will use in our device will be provided by our sponsor Everix. The filters created by Everix, have a very small thickness in the tens of microns range whereas other optical filters on the market have a thickness of 1-3 mm. This enables our device to be a step closer to our goal of having our device be compact and portable.

The next component used in our fluorescence detection optical sub system is a lens used to collimate fluorescence light and reflected LED light onto the optical filter before transmission into the photodiode. The focal length of the lens will be designed to have a small focal length,  $f < 30$  mm, and a small thickness so that this subsystem can meet our device size of  $85 \times 45 \times 20 \text{mm}^3$ . This will have to be balanced out with having a large diameter lens so that the detection optical subsystem is able to collect as much fluorescent light as possible, while still obtaining a small enough focal length to fit into the compact size requirements of our device.

The last optical component to be discussed within this sub system is the photodetector. After investigating the features and parameters of various photodetectors we have come to the conclusion that the photodiode will be the photodetector that is most suited for integration in our device. The active area size of the photodiode must be chosen so that the spot size of the light focused from the lens falls within the active area. The photodetector will have a wavelength range of 350-1100 nm to allow for the detection of many different fluorophore fluorescence wavelengths including the 515 nm peak fluorescence wavelength of fluorescein.

Properties	General Optical Bandpass Filter	Everix Optical Bandpass Filter	Focusing Lens	Photodiode
Refractive Index	-	~1.5	1.45-1.55	NA
Focal length	NA	NA	< 30 mm	NA

Thickness	1-3 mm	0.01-0.015 mm	1-10mm	NA
Spectral Bandwidth	340-12,000nm	340-12,000nm	NA	350-1100 nm

Table 10 Fluorescence Detection Subsystem Components & Properties

The LED is used to excite the sample concentrations of fluorophores to produce fluorescent emission light which will be collected by the detector. The LED which we have chosen for our optical design is a Thorlabs LED named LED465E. This LED has a radius of approximately 3 mm and a half viewing angle of  $8^\circ$ .

### 5.3.1.1.1 Determination of LED position and rotation

#### 5.3.1.1.1.1 Light Cut-Off Case

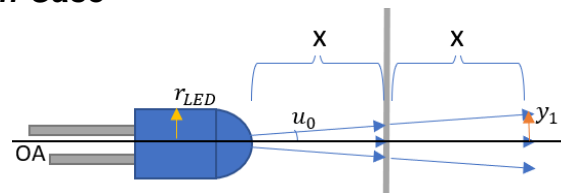

Figure 32 Diagram of light cut-off case for LED reflected light

In this case the rotation of the LED is at an angle of  $0^\circ$  with respect to the optical axis. The half viewing angle of the LED is represented by  $u_0$  in Fig 34. The half viewing angle also represents the largest angle, with respect to the optical axis, that light will be emitted from the LED. The radius of the LED is represented by  $r_{LED}$  in Fig. 34. The optical axis is represented by the black horizontal line in Fig. 34. The distance between the LED and the sample container is represented by “x” in Fig. 34. The gray vertical line represents the interface of the sample container, and it is important to note that the light rays represented on the right side of the gray line represent the reflected light from the LED rather than the transmitted light going into the sample container. The height of the reflected LED light rays upon returning to the distance “x” away from the sample container is represented by  $y_1$  in Fig. 34. This calculation was done to determine at what distance “x” away from the sample container will the reflected LED light be blocked by the radius of the LED.

$$(7) r_{LED} \geq y_1 = y_0 + 2u_0 \times (x)$$

$$(8) x \leq \frac{r_{LED} - y_0}{2u_0} = \frac{3 \text{ mm} - 0}{2(0.1396 \text{ rad})}$$

$$x \leq 10.743 \text{ mm}$$

By inputting the specifications for a Thorlabs LED465E, including an LED radius of  $\sim 3$  mm and a half viewing angle of  $8^\circ$  or 0.1396 radians, into the equation 8 gives an output range of 0 to 10.742 mm from the LED to the sample container. This means that if this

particular LED is placed at a distance 10.743 mm or less and the LED is parallel to the optical axis, than the excitation light will be cut off and a majority of fluorescence light will not make it past the LED.

### 5.3.1.1.2 Calculation of LED Rotation Angle

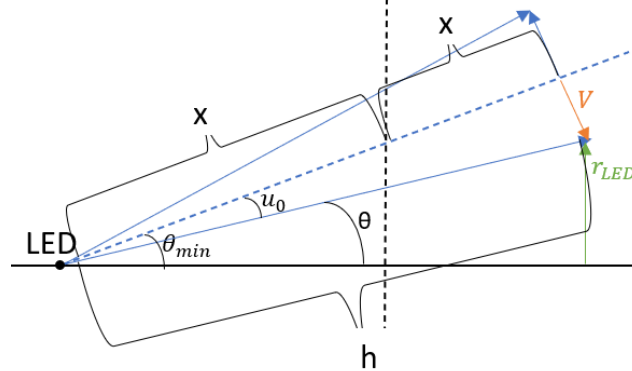

Figure 33 Diagram of the rotation of the LED and light emission reflected off the sample

Fig. 35 depicts an LED rotated at an angle represented by  $\theta_{min}$ . The LED in Fig. 35 is rotated such that the half viewing angle of the LED ( $u_0$ ) just barely touches the end of the LED's radius ( $r_{LED}$ ). Similar to Fig. 35, the distance between the LED and the sample container is represented by "x". It is important to note that the black dotted line in Fig. 35 represents the sample container interface and the part of the diagram depicted on the right side of the vertical dotted line represent the reflected portion of the light emitted by the LED. In Fig. 35 same as in the previous Fig. 34, the radius of the LED is represented by  $r_{LED}$ . As seen in the previous Fig. 34, the half viewing angle of the LED is represented as  $u_0$ . Height of the half viewing angle ray as it touches the radius of the LED is represented by "V". The path length of the ray traveling from the LED source and then reflected back to the LED radius is represented by "h" in Fig. 35. Theta ( $\theta$ ) is found by the following equation  $\theta = \theta_{min} - u_0$ .

$$(9) V = V_0 + 2u_0(x)$$

$$(10) \frac{V}{h} = \sin(u_0)$$

$$(11) \frac{r_{LED}}{h} = \sin(\theta)$$

$$(12) \frac{r_{LED}}{\sin(\theta)} = \frac{V}{\sin(u_0)}$$

$$(13) \theta_{min} \geq \sin^{-1}\left[\frac{r_{LED} \sin(u_0)}{V_0 + 2u_0(x)}\right] + u_0$$

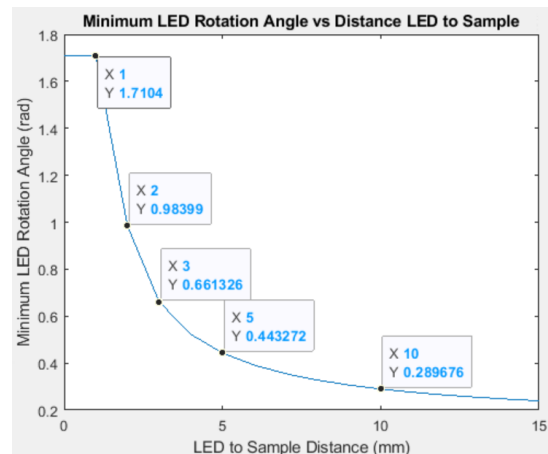

Figure 34 Minimum rotation angle of LED plot of equation 13

Equation 13 gives the minimum LED rotation angle value at a particular distance from the LED to sample container. Using the previously mentioned specifications for the LED radius (~3 mm) and half viewing angle (0.1396 rad), the graph in Fig. 36 can be created with the minimum angle values on the y-axis in units of radians and the values for distance from the LED to the sample container in units of millimeters on the x-axis. The graph in Fig. 36 ignores the imaginary and complex components of “x” and  $\theta_{min}$ . When taking into account the complex components, the minimum valid distance from the LED to the sample container is 1.5 mm and the minimum LED rotation angle at that distance is  $93^\circ$ . As the graph of equation 13 in Fig. 36 clearly shows, the minimum rotation angle of the LED with respect to the normal of the sample increases as the distance between the LED and sample decreases. With our device it is best that we excite and detect the sample fluorophore solution from a small distance away from the sample. Having a small distance between the LED and sample container will help enable our device to achieve our goal of being compact. As seen in the Fig. 36 if we decrease the distance between the LED to be very small such as at 1.5 mm, then the minimum rotation angle of the LED would be  $\sim 93^\circ$  which is not an effective angle for the excitation of the sample fluorophore and subsequent detection of the fluorescence emission. A large minimum rotation angle of the LED will make the LED closer to parallel to the sample which would make it much harder to collect the LED light reflected off the sample interface and collimate it so that the excitation light is at a normal incidence angle to the optical filter allowing for effective elimination of excitation light from reaching the detector.



### 5.3.1.1.2 Calculation of Distance Between LED and Collimating Lens:

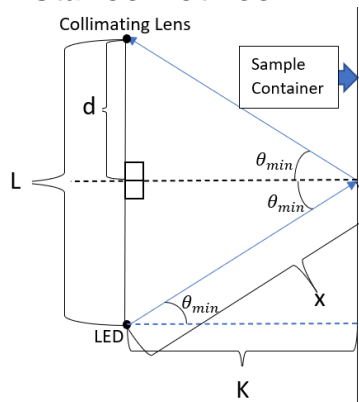

Figure 35 Diagram of the separation between LED, collimating lens, and the sample container

Fig. 37 shows the LED excitation light reflected off the sample container and subsequently collected by the collimating lens before the light passes through an optical filter and then is detected by the photodiode. Similar to the previous calculations 'x' and  $\theta_{min}$  represent the distance from the LED to sample container and the minimum LED rotation angle to allow reflected excitation light to reach the collimating lens without being cut off by the size of the LED respectively. The distance from the LED to the sample which is normal to the sample container interface is represented in Fig. 37 by a "K". The distance between the LED and collimating lens is represented by a "L" in Fig. 37 and half of that distance is represented by the letter "d". The following equations can be used to calculate the distance "L" with respect to  $\theta_{min}$  and "x".

$$(14) K = (x)\cos(\theta_{min})$$

$$(15) L = 2d = 2(x) \sin(\theta_{min})$$

$$(16) L = 2(x) \sin \left[ \sin^{-1} \left[ \frac{r_{LED} \sin(u_0)}{V_0 + 2u_0(x)} \right] + u_0 \right]$$

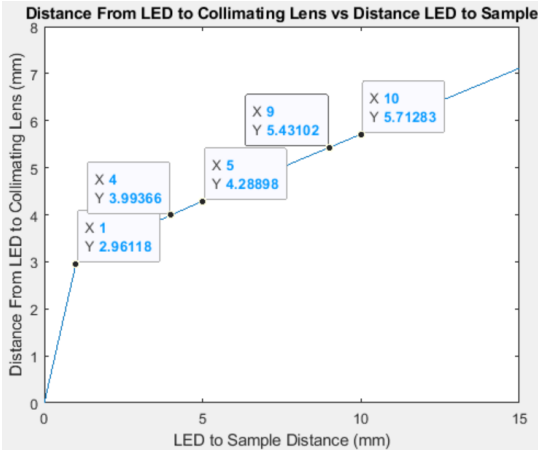

Figure 36 Diagram showing the plot of equation 16 shifted down by 3 mm

The graph depicted in Fig. 38 uses equation 16 along with previous radius and half viewing angle specifications from Thorlabs LED465E. The imaginary and complex components of “x” and “L” are ignored in the graph shown in Fig. 38 but when you account for the complex components then the smallest valid distance in “x” is 1.5 mm. At the smallest valid distance value in “x”, the smallest distance between the LED and collimating lens is found to be 3 mm. In the graph on Fig. 38, as the distance between the LED and sample container decreases, the distance between the LED and collimating lens decreases to a minimum of 3 mm. Equation 14 shows how to convert from distance “x” from LED to sample container to distance “K” from LED to sample container.

Paraxial ray tracing was used in the foundational design of these subsystems. Paraxial ray tracing enables the ballpark determination of the proper distances between optical components and their respective focal lengths.

Paraxial Refraction Equation:

$$(17) \quad n_{i+1}u_{i+1} = n_i u_i - \phi_{i+1} y_{i+1}$$

Paraxial Translation Equation:

$$(18) \quad y_{i+1} = y_i + d_i u_i$$

Equation for Optical Power:

$$(19) \quad \phi_{i+1} = \frac{n_{i+1} - n_i}{R_{i+1}} = \frac{-n_i}{f} = \frac{n_{i+1}}{f}$$

**5.3.2 Fluorescence Detection Optical Sub System Paraxial Ray Trace:**

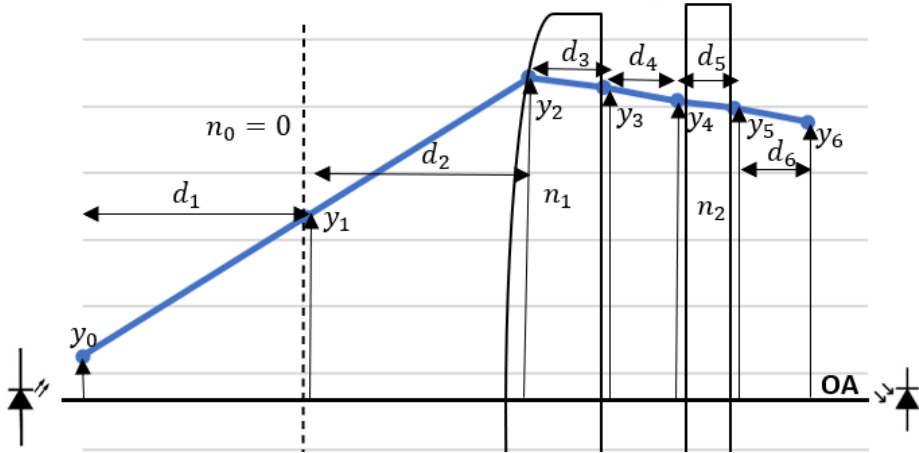

Figure 37 Fluorescence Detection Optical Sub System Paraxial Ray Trace

Paraxial Ray Trace Matrices

$$\begin{bmatrix} y_6 \\ n_6 u_6 \end{bmatrix} = \begin{bmatrix} 1 & d_6/n_0 \\ 0 & 1 \end{bmatrix} \begin{bmatrix} 1 & d_5/n_2 \\ 0 & 1 \end{bmatrix} \begin{bmatrix} 1 & d_4/n_0 \\ 0 & 1 \end{bmatrix} \begin{bmatrix} 1 & 0 \\ -n_0/f & 1 \end{bmatrix}$$

$$\begin{bmatrix} 1 & d_3/n_1 \\ 0 & 1 \end{bmatrix} \begin{bmatrix} 1 & 0 \\ -n_1/f & 1 \end{bmatrix} \begin{bmatrix} 1 & d_2/n_0 \\ 0 & 1 \end{bmatrix} \begin{bmatrix} 1 & d_1/n_0 \\ 0 & 1 \end{bmatrix} \begin{bmatrix} y_0 \\ n_0 u_0 \end{bmatrix}$$

Figure 38 Fluorescence Detection Subsystem Paraxial Ray Trace Matrices

These paraxial equations take into account in the lens design for this optical system going forward with the new design with a plano-convex lens to collimate the light. The dotted line in Fig. 39 represents the reflection interface on the sample container which the LED light emission will reflect off of. The matrices in figure 40 use the Paraxial Refraction and Translation equations to trace rays coming from the input of this subsystem to the output of this optical sub system. Figure 39 shows the paraxial ray trace starting from fluorescent light emitted from the fluorophore as input at  $y_0$  to the photodiode used to detect the light at  $y_5$ . The paraxial ray trace distances  $d_1, d_2, d_3, d_4, d_5,$  and  $d_6$  in figure 39 represent the from the distance from the LED light source to the sample container, reflection from the sample container to the collimating plano-convex lens, the thickness of the collimating lens, from the collimating lens to the optical filter, the thickness of the optical filter, the distance from the optical filter to the photodiode. The paraxial ray trace heights, with respect to the optical axis,  $y_0, y_1, y_2, y_3, y_4, y_5$  and  $y_6$  in figure 39 represent height of the

ray emitted from the LED, the height of the ray at air to sample container interface, the height of the ray at the air to collimating lens interface, the height of the ray at the collimating lens to air interface, the ray height at the air to optical filter interface, the ray height at the optical filter to air interface and the height of the collimated light once it reaches the photodiode detector. The first optical component in the paraxial ray trace in figure 39 is the plano-convex collimating lens. This lens is considered to be a collimating lens within the optical design of our device because the lens is used to collimate fluorescence emission light and LED light emission on to the optical filter and then transmitted to the photodiode at  $y_5$  in figure 39. The paraxial ray trace for the collimating lens ray trace has two paraxial refraction matrices and one paraxial translation matrix. The second optical component in this subsystem's ray trace is the optical filter. The optical filter in figure 39 is displayed as having a refractive index of  $n_1$ . This optical bandpass filter will filter out the wavelengths within the EM spectrum which are not the fluorescence wavelength of the fluorophore dye used in the sample. This eliminates the detection of excitation wavelength light reflected off the sample and into this detection sub system. As mentioned before, the paraxial ray trace of the optical filter is approximated to be a change in translational medium since an optical filter has a very large curvature and therefore has a very large focal length which can be approximated to be nearly infinite when we are dealing with a scale of tens of millimeters.

The paraxial ray trace of the excitation and fluorescence emission in the detection optical sub system allows us to get an approximate determination of the distances which the optical components such as the lenses, optical filters, LED, and photodiode should be placed within our optical design. Variables of importance for determination of the distancing of components for the correct outputs include focal length ( $f$ ), thickness ( $d_3$ ) and refractive index ( $n_1$ ) of both the collimating and focusing lenses, thickness ( $d_5$ ) and refractive index ( $n_2$ ) of both optical filters, and the relative active area of the photodiode ( $y_6$ ) and LED ( $y_0$ ). After using these paraxial ray traces to find the approximate distances for optical component placement, a ray trace, with higher accuracy to real ray paths, is performed using the Zemax software to more effectively optimize our device's optical design.

$$(20) NA = n \sin \theta_A$$

Equation 20 represents the formula to solve for the numerical aperture of a lens or optical system. The refractive index ( $n$ ) represents the refractive index of the medium between the object and the lens [9]. In the case of our fluorescence detection subsystem, as seen in figure 31, the refractive index between the sample object and the focusing lens is mostly air ( $n_0 = 1$ ) and a small distance of the order of tens of microns worth of optical filter refractive index ( $n_1 \approx 1.5$ ). We have been told by our sponsors Everix that their optical filters are thin enough that the refraction of light is fairly negligible. This allows us to approximate the refractive index between the fluorescent light emitting sample and focusing lens to be the refractive index of an air medium. The symbol  $\theta_A$  represents half of the acceptance angle of the cone of light entering the optical system. This half acceptance angle can be found from a marginal ray trace. The marginal ray is a ray which

originates from the optical axis (OA) at the object’s location and travels through the optical system to the edge of the entrance pupil and is the largest ray angle that passes through the aperture stop [10]. Knowing the numerical aperture of our optical design will give us an idea of fluorescent light that can enter our detection optical system.

$$(21) \quad F/\# = \frac{f}{D} \approx \frac{1}{2NA}$$

Equation 21 represents the formula to solve for the f-number of a lens or optical system. The f-number is the ratio of the focal length of a lens to the aperture diameter of the optical system [11]. The higher the f-number smaller the aperture and the lower the amount of light that passes through the lens [11]. The lower the f-number the larger the aperture and the higher the quantity of light passing through the lens [11]. In the case of our device, we are looking to have a small f-number for our fluorescence detection optical system because we want to collect as much of the fluorescent light emitted from the fluorophore as possible. The  $f$  in the formula represents the focal length of a lens or effective focal length of an optical system usually described in units of millimeters. The  $D$  in the above formula is the diameter of the lens or entrance pupil of the optical system and is usually represented in units of millimeters. An approximation of the f-number can be found using the value for the numerical aperture for an optical system. The focal length and diameter of a lens are typically given in the specifications section on a lens buying web page. For our device we need small focal length lenses ( $f < 30$  mm) for our optical design so that our device can achieve the goal of having a compact and portable size. We also want a large aperture diameter so that we can catch as much of the fluorescent light emission as possible the detection sub system of our device. Achieving a low f-number will allow our device to collect as much fluorescent light emission as possible mean. In the case of our device, we can achieve both of our goals of having a compact optical design as well as maximizing our collection of fluorescent light emission input into our detection optical sub system, by choosing a focusing lens with a small focal length and a large diameter relative to its small focal length.

**5.3.2.1 Paraxial Ray Trace with Resulting Filter Angle of Incidence & Blue Shift**

LED source radius 2.5 mm				Reflected LED Light		Fluorescent Light Emission	
LED reflected light distance (mm)	radius (mm)	focal length (mm)	Lens to sample Distance (mm)	angle of incidence (filter units: radians)	500nm cut off Wavelength Shift (nm)	angle of incidence (filter units: radians)	500nm cut off Wavelength Shift (nm)
6	2.7	6	3	-0.41666668	481.4568299	-0.346866679	486.9898599
8	3.6	8	4	-0.312500015	489.3852778	-0.242700013	493.5409689
10	4.5	10	5	-0.250000017	493.1521371	-0.180200014	496.418049

12	5.4	12	6	-0.208333351	495.2240263	-0.138533348	497.8767104
14	6.3	14	7	-0.178571448	496.4820399	-0.108771444	498.6888764
16	7.2	16	8	-0.156250021	497.3020508	-0.086450016	499.1709788
18	8.1	18	9	-0.138888911	497.8658441	-0.069088906	499.4701985
20	9	20	10	-0.125000023	498.2699185	-0.055200017	499.661669
22	9.9	22	11	-0.113636388	498.5693153	-0.043836382	499.7865769
24	10.8	24	12	-0.104166693	498.7972745	-0.034366685	499.8688045
26	11.7	26	13	-0.096153873	498.9748258	-0.026353865	499.9228423
28	12.6	28	14	-0.089285743	499.1157979	-0.019485734	499.9578154
30	13.5	30	15	-0.083333363	499.2295854	-0.013533354	499.9796506

*Table 11 Paraxial Ray Trace with Resulting Filter Angle of Incidence & Blue Shift Table*

This paraxial ray trace was conducted with the assumption of an LED light source radius of 2.5 mm and a starting half viewing angle of 8° or 0.1396 radians for the blue LED. The LED light emission radius and half viewing angle come from the specifications for the Thorlabs LED465E which we will be using in our device. This paraxial ray trace was conducted with the assumption that the potential plano-convex lens will have a refractive index of 1.45. The light emitted by the LED465E has a peak intensity measured at 474 nm in our preliminary emission spectrum testing. As mentioned in the Preliminary Testing section in this document, the FWHM of the LED465E emission spectrum was measured to be 23.19 nm. When looking at the LED spectrum the intensity of the light decreases from the peak at 474 nm to a very small intensity close to the noise level at 500 nm.

We have chosen a long pass optical filter with a cut off threshold at 500 nm. A 500 nm cut off threshold will allow us to cut off the light from the LED with minimal leakage and a marginal portion of the fluorescent emission light cut off. The long pass optical filter works like a high pass filter by cutting off all light emission below a wavelength of 500 nm. As discussed in the section titled Angular Shift in Filters, rays of light hit our optical filter at large angles of incidence the threshold of the optical filter will shift toward shorter wavelengths of light and allow LED excitation light of a high intensity to leak through our optical filter. Blue shift is an important parameter to minimize in our device so that our device can accurately detect the right concentration of fluorophores within a solution and so that our device does not falsely detect a higher concentration of fluorophores within a solution to blue light leaking into the photodiode.

In order to minimize blue shift as much as possible we have decided to use a plano-convex lens to collimate the reflected light from the LED and the fluorescence light emission from the sample onto the optical filter. The fluorescence light spectrum occurs

at wavelengths above 500 nm and will therefore be minimally affected by the blue shift. It is more important for us to minimize the angle of incidence for the reflected LED light passing through the optical filter because the light coming from the LED is within the wavelength range where it could leak through the optical filter due to the blue shifted threshold. To collimate the LED light reflected off the sample, the focal length of the plano-convex lens must be chosen to be equal to two times the distance between the LED and the sample container. This also means that the fluorescence emission from the sample container will be collected by the plano-convex lens at a distance 50% shorter than the focal length of the lens. Table 11 shows the angle of incidence acquired from a paraxial ray trace and blue shifted optical filter threshold calculated, using the equation in figure 55, for both the LED reflected light and the fluorescence emission light. Table 11 shows blue shifted filter threshold values and angles of incidence values' dependence on focal length of the plano-convex lens. When comparing the blue shift threshold of the LED reflected light and fluorescence light emission it can be seen that the fluorescence light emission has a sharper increase in blue shift filter threshold when the focal length is increased. It can be seen in table 11 that as the focal length increases, the blue shifted filter threshold climbs closer and closer to the designed threshold value of 500 nm. It can also be seen that as the blue shifted threshold value gets closer to the designed threshold value, than the blue shift value will increase at a smaller and smaller rate with continued increase in focal length.

Knowing that the blue shifted filter threshold becomes closer and closer to the designed filter threshold of 500 nm at longer focal lengths, it would appear that we need to choose a lens with a large focal length. While choosing a longer focal length such as 30 mm for example will enable a blue shift in the optical filter threshold of less than one nanometer, the 30 mm focal length would require a much a distance of 15 mm between the plano-convex lens and the sample container. A 30 mm focal length will also require a large lens diameter which in combination with a distance of 15 mm will further increase the size of the optical design system such that we will no longer be able to make our device fit within our size constraints of  $85 \times 45 \times 20 \text{ mm}^3$ . In order to fit within our size constraints and minimize the amount of blueshift in our optical filter threshold we must optimize the two values. To determine the optimal focal length value to use in our device we must determine how much blueshift in the optical filter would we be willing to deal with in our device in order to have a more compact optical system and what how much space are we willing to allow the optical system to expand to in order to minimize the blue shift in the optical filter threshold.

The filters that Everix produces have an angle of incidence tolerance of  $0^\circ$  to  $25^\circ$  or 0 to 0.4363 radians. This means that the angle of incidence of  $-0.41667$  from the reflected LED light ray trace, when the plano-convex lens is at a focal length of 6 mm, will be completely blocked out by the tolerance of the optical filter provided by Everix. This allows us to minimize the distance between the plano-convex lens and the sample container.

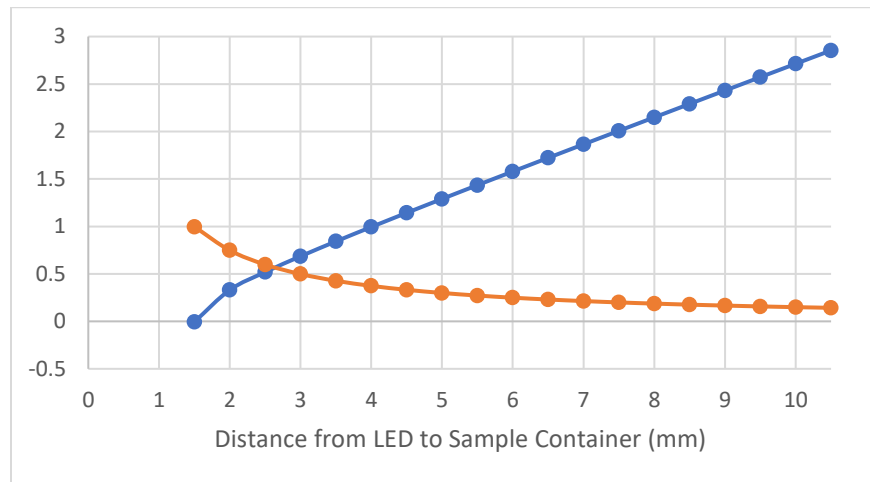
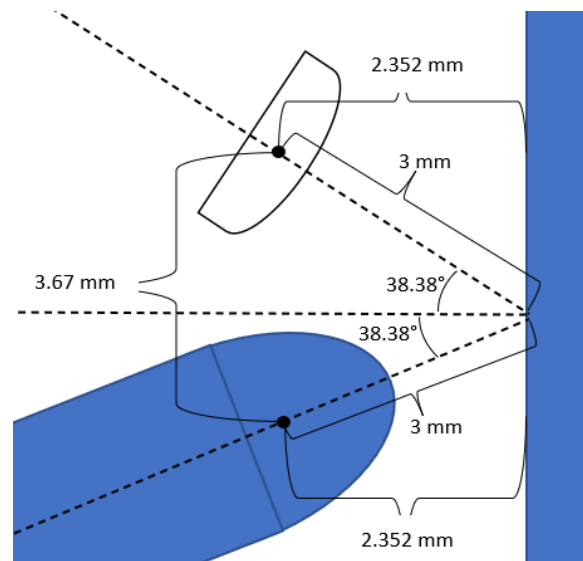

Figure 39 Minimum rotation angle & distance between LED and plano-convex lens vs. LED to sample container distance

Figure 52 shows the curve shows the red curve representing equation 13 for the minimum angle of LED rotation needed and the blue curve representing equation 16 used to find the distance from LED to collimating lens. The 3 mm LED radius and 8° half viewing angle were substituted into the equations for these two curves so that a minimum angle and distance from LED to collimating lens could be obtained with a single input of distance on the x-axis representing the distance from the LED to the sample container. The blue curve normally has a minimum distance of 3 mm between the LED and collimating lens. This minimum distance was subtracted from equation 16 in order to obtain the point at which the LED can be placed as close to the collimating lens as possible while having a small angle of rotation. The maximum angle that the LED can rotate is found to be 45°. This maximum angle is due to the equal and opposite rotation of the collimating lens which makes an LED rotation angle of 45° equate to a 90° angle difference between the LED and collimating lens. This means that at LED rotation angles larger than 45° the angle between the LED and collimating lens will become closer to 180° which will allow more light direct LED light to leak into the collimating lens and optical filter system.

Leakage of LED light and a compact optical system size are both factors that we are looking to optimize in our system. When optimizing our optical system design for the two factors previously mentioned we find a minimum rotation angle of 0.67 radians or 38.38° and an optimal distance “L” from LED to collimating lens of 3.67 mm. The distance from LED to collimating lens at which this optimal point occurs is at 2.954 mm which can be approximated to ~3 mm. Double the distance from the LED to sample container is also the approximate distance that the focal length should be in order to collimate as much reflected LED light as possible while also collecting the fluorescent light originating from the sample container. In this case the focal length of the plano-convex lens would need to be ~6mm when the LED and plano-convex lens are positioned at ~3 mm distance away from the sample container. With the optimal “x” distance of ~3 mm, the optimal distance “K” can be calculated, using equation #, to be 2.368 mm.





*Figure 40 Positioning of LED and plano-convex lens orientation*

Taking into account the radius and half viewing angle specifications of the Thorlabs LED465E, the paraxial ray trace of our rotated optical detection system, and the blue shift in the optical filter threshold we can determine the dimensions and component positions of our optical design. As previously mentioned in the Plano-convex Lens & Blue Shift section, the minimum focal length which lies within the tolerated angle of incidence on the Everix optical filter is a focal length of 6 mm. The plano-convex lens will be placed at a 3 mm distance away from the sample container so that it can most effectively collimate the LED light reflected off the sample container. The Thorlabs LED465E will be placed at a distance of 3 mm away from the sample container so that the LED minimum angle will be optimally small while keeping the distance between the plano-convex lens and LED optimally small as well. At this position both the plano-convex lens and the LED will be approximately 2.352 mm away from the normal of the sample container. The optimal minimum rotation angle for the LED is  $38.38^\circ$ . The plano-convex lens will be rotated at an equal and opposite angle of  $-38.38^\circ$  so that the reflected LED light can be most effectively collimated. This means that there will be a total minimum rotational angle of  $76.76^\circ$ . The optimal distance between the LED and plano-convex lens is 3.67 mm. In analyzing the Paraxial Ray Trace with Resulting Filter Angle of Incidence and Blue Shift Table, we came to the conclusion that the optimal focal length of 6 mm enables our optical design to fit into a small size while refracting reflected LED light onto the optical filter at an angle of incidence of  $-0.41667$  which lies within the tolerance range of the Everix optical filters. We need a small  $F/\#$  to collect the most light possible from both the fluorescence light emission and LED emission. In order to achieve a small  $F/\#$  we need to choose a lens with a diameter that is close to the size of the focal length of the lens. With a low  $F/\#$  in mind we will choose a plano-convex lens with a diameter of 6 mm to complement the optimal focal length of 6 mm. For our optical design we have decided to choose an uncoated plano-convex lens from Edmund optics with an effective focal length of 6 mm

and a diameter of 6 mm so that we can collect as much fluorescent light from emitting from the sample without compromising our optimal focal length.

### 5.3.3 Overall Case 1 Optical Design

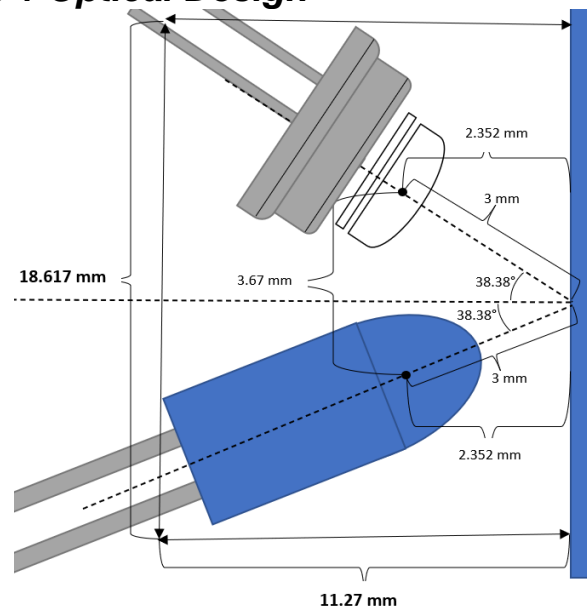

Figure 41 Overall Case 1 Optical Design Layout

Figure 43 above represents our overall optical design for case 1 which uses reflection of LED light and surface emission of fluorescent emission light. The diagram in figure 43 highlights the overall dimensions in length and in width of the current optical design. The overall current optical design has dimensions of approximately 11.5 mm in length by 18.75 mm in width. The height of the optical system will be approximately 8.3 mm which is the height of the largest component the Si-photodiode FS100. The LED chosen for our optical design and represented as the LED in figure 43 is the Thorlabs LED465E which has a diameter of 6 mm and a dome length of 9 mm. The plano-convex lens shown in the diagram represents the Edmund's Optics Uncoated Plano-convex lens with a 6 mm effective focal length and 6 mm diameter. Everix's optical filters are so thin that they are within the tens or hundreds of micrometer range which enables us to decrease the dimensions of our optical design significantly compared to typical optical filters which have a thickness of 1 to 3 mm. By using trigonometric calculations, it can be found that the substitution of a typical optical filter would have increased the length of our optical system by a value ranging from 0.784 to 2.35 mm. The diode component depicted right behind the flat optical filter in figure 43 represents the FS100 Si-photodiode, which has a diameter of 8.3 mm and a thickness of 3.5 mm from opening to the start of the contacts on the back of the photodiode. The dimensions of the overall optical design take into account the dimensions of each of the components used in the optical system.

**5.3.3.1 Overall Optical Design Dimension Calculations**

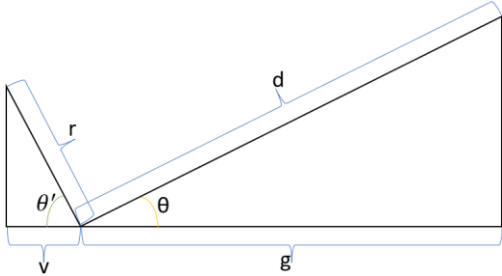

Figure 42 Geometric representation of optical design width

$$v = r \cos(\theta') = (3 \text{ mm}) \cos(51.62^\circ) = 1.863 \text{ mm}$$

$$g = d \cos \theta = (12 \text{ mm}) \cos(38.38^\circ) = 9.407 \text{ mm}$$

$$X = v + g = 11.27 \text{ mm}$$

Figure 44 is a geometric representation of the length of the optical system. The length “X” of the optical system is equal to the sum of the two distances represented by “v” and “g” in figure 44. The letter “r” represents the radius of the component furthest away from the fluorescence emitting sample container. The letter “d” in figure 44 represents the total distance from the sample to the end of the last component. Theta (θ) represents the rotation angle of the component furthest away from the sample container. In the case of our optical design the value of theta will be 38.38°.  $\theta' = 180 - 90 - \theta = 51.62^\circ$ .

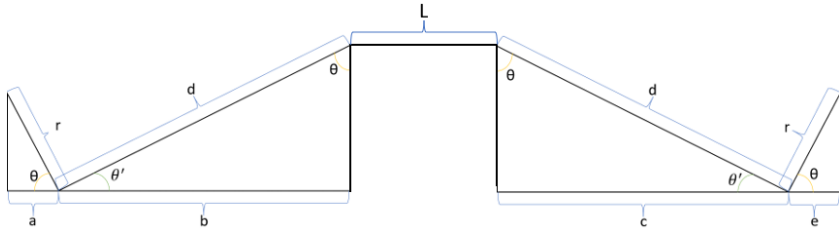

Figure 43 Geometric diagram of length of optical design

$$a = r \cos(\theta) = (4.25 \text{ mm}) \cos(38.38^\circ) = 3.332 \text{ mm}$$

$$b = d \cos(\theta') = (5.92 \text{ mm}) \cos(51.62^\circ) = 3.675 \text{ mm}$$

$$c = d \cos(\theta') = (9 \text{ mm}) \cos(51.62^\circ) = 5.588 \text{ mm}$$

$$e = r \cos(\theta) = (3 \text{ mm}) \cos(38.38^\circ) = 2.352 \text{ mm}$$

$$Y = 3.67 \text{ mm} + a + b + c + e = 18.617 \text{ mm}$$

Figure 45 is a geometric representation of the width of the overall optical system. The width “Y” of the optical system is equal to the sum of the five distances in the diagram represented by a, b, c, e, and L. The distance “L” represents the optimal calculated distance between the LED and the plano-convex lens from the section labeled Calculation of Distance Between LED and Collimating Lens. The letter “r” represents the radius of the

furthest component from the sample. The letter “d” represents the distance from the last component to the sample container minus 3 mm.

### 5.3.3.2 Zemax Optimization

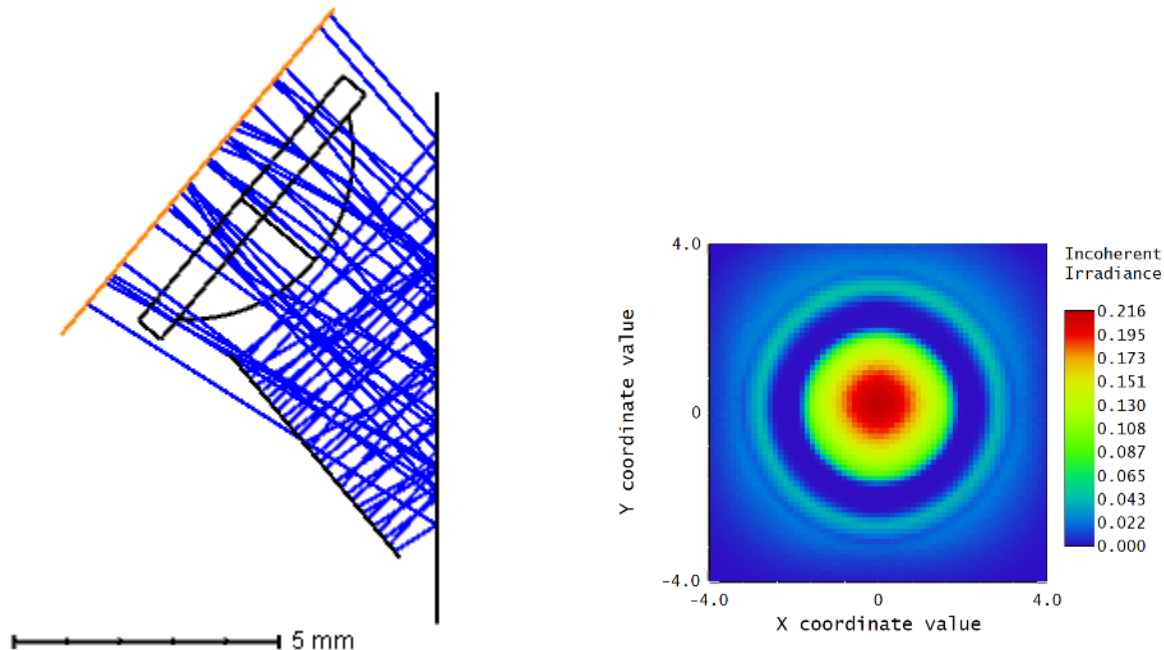

Figure 44 Case 1 optical design Zemax optimization

Case 1 of our optical design deals with reflection of LED light off the sample surface as well as rotation of our LED excitation light source and plano-convex lens. The factors just mentioned necessitate the use of the non-sequential ray trace mode in Zemax to simulate the reflected rays from the LED at off axis angles while having a rotated plano-convex lens at the same distance away from the sample. We have optical system simulations for case one using Zemax in the non-sequential ray tracing mode, but we have found difficulties in managing the errors that we have come upon while optimizing. Although members of our team are well versed in the optimization of lens systems using the sequential ray tracing mode through previous courses that we have taken. We are inexperienced in how to manage effective optimization and ray tracing in the non-sequential mode since none of the members of our team have taken courses which have touched upon or taught in depth how to use the non-sequential ray trace and how to best deal with errors. Figure 46 shows the closest that we were able to construct a ray trace through the non-sequential ray trace mode.

Our attempts to optimize the design and the myriad of complexities resulting from the emission of the LED as well as its rotated angle have led to a need to simplify our optical design. The process of optimizing and simplifying our optical design in Case 1 has turned

into a new design approach, Case 2, which leverages much of the original design and sets the stage for new simplified tests. These new tests are already showing promise as will be discussed further in the Case 2 Optical Design section and the Prototype Testing Section.

### 5.3.4 Case 2: Fluorescence Detection Optical Subsystem with Curved Filter

We have decided to change the optical design from using two filters to just using one filter that goes in front of the photodetector.

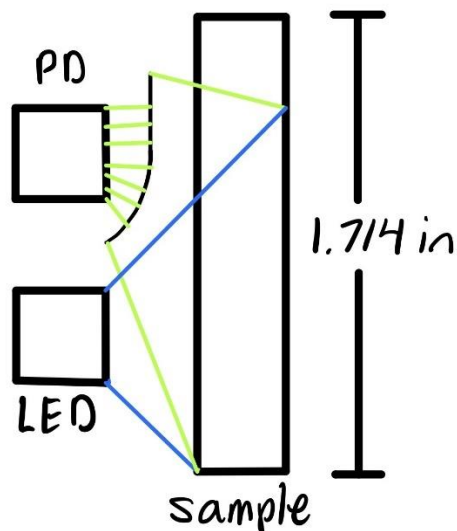

Figure 45 New Optical Design

#### 5.3.4.1 Curved Filter

The need for a curved optical filter is important in the design process of fluorescence sensing because of the minimization to the end size of the device. In this new optical design, we will be using one long pass filter that is at a cut-in wavelength of 500 nm to block out all of the LED emission light. Looking at the drawn optical design, the light coming from the LED will hit the sample at an angle causing the excitation light from the sample to travel to the photodetector at an angle as well which will cause the optical filter to be curved. The upper portion of the optical filter does not need to be curved because the light coming from the sample will hit the filter at an incidence angle of zero degrees, although below the half way mark on the filter, there will need to be a curve set to allow the light that is being emitted to travel perpendicular to the filter at all angles.

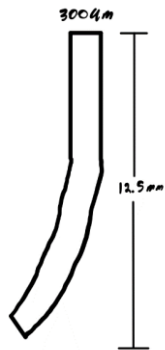

Figure 46 Curved Filter

From the figure, the width of the optical filter is around 300 microns allowing the filter to form to any shape using a vacuum forming technique. The length of the filter will vary depending on the final constraints of the design, but the standard industry length is 12.5 mm but will most likely be shorter to accommodate the size of the photodetector. In front of the filter, not shown in the diagram will be a lens which will collimate the light coming from the sample. The lens will be of the same dimensions of the optical filter and the filter will sit right next to the lens to allow the most light to be filtered.

The need for a higher optical density is an important factor in fluorescence sensing. Most devices that use optical filters are able to use a lower optical density because there is a wide range for the selective wavelength. In the case of fluorescence spectroscopy, because the emission and excitation wavelength are so close in proximity, and we are sensing at a very tight scale we will need an optical density of 6 or greater for the excitation filter. The optical density of any material is the log of the intensity of the incident light on the material over the intensity of the transmitted light after the material. The ratio of these two factors will allow us to design a long pass optical filter that will have an optical density of 6 or greater.

#### 5.3.4.2 Angular shift in filters

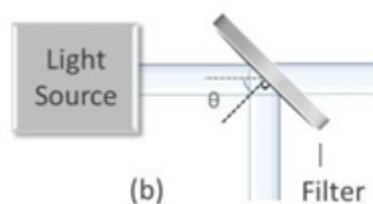

Figure 47 Diagram depicting wavelength and angular shift due to angle of incidence

Optical filters exhibit different properties depending on the incident light onto the filter. Snell's law shows that as the incident light shines into the filter the angle changes after the light enters the filter. This is persistent with glass, plastic and other materials that have a refractive index other than one. Most optical filters are made with a thick glass

material and the deviation after the filter would need to be accounted for, Everix filters are so thin, we will negate Snell's law because of the thin film. We will only take into account incident light that is tilted at a non-normal angle.

$$\lambda_{\theta} = \lambda_0 \sqrt{1 - \left( \frac{n_o}{n_{eff}} \sin \theta \right)^2}$$

Figure 48 Equation for blue shift

With the incident refractive being one, the wavelength at normal incidence is 500nm for the cutoff wavelength of the long pass filter, the effective refractive index of the filter is 1.5. Going below 500nm for the long pass filter will result in a high noise into the detector and can result in a false reading. To minimize the angle of incidence we will use a maximum wavelength shift of 1nm. This leads to an angular incidence of 5.44 degrees from the normal. As the incidence angle increases away from the normal, the angular shift will increase rapidly which is why we want to stay at very small angles.

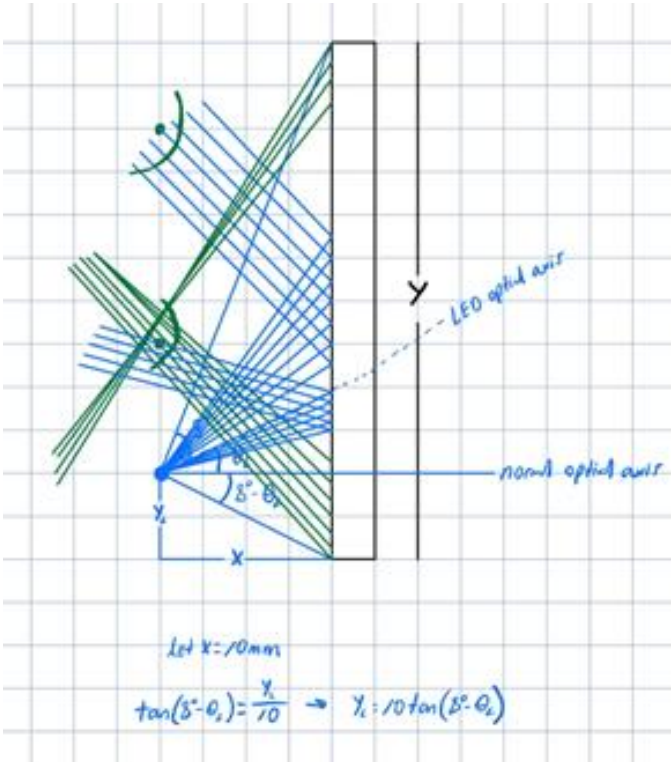

Figure 49 Calculations and depiction of angles of incidence of light from an LED source

Assuming the LED is a point source, we can see two different scenarios in the sketch. One with the detector (green) close to the LED and the other is further away. This shows the importance that the distance has on the angular shift of the filter. As the filter is moved closer to the LED, the reflection angle from the sample is minimized and therefore the angle of incidence of the blue light onto the filter is also minimized and

wont leak to cause a false reading on the detector. The other important aspect of the filter is the type of curvature. From the sketch it would be ideal to have a parabolic arc in the shape of the filter in a 2D path. Although the z direction is considered, the sample will be in the form of a rectangle and have a width to minimize the light in the z direction. Previously we were going to use a glass vial as the sample container, the flaws are clear as the curvature of the glass will make the fluorescence and reflecting light refract into many directions minimizing the amount of light traveling to the filter.

#### **5.3.4.3Simpler transmissive optical design testing**

A new optical system has been found by testing the idea of using a UV LED. Up until now, the optical system compromises of a blue LED that has a wavelength peak of around 465 nm. One of the main issues that has come up using this type of LED is the wavelength difference between the LED and the fluorescence. As the wavelengths get closer together, it becomes much harder to block out the LEDs wavelength because the filter would need to have a much sharper cut on wavelength if using a long pass filter. The new design testing took place on 12/03/2021 at the company Everix. The main issues we were trying to solve was figuring out a potential solution for an LED that would fluoresce the material but also provide enough power to end up at the detector end.

Optical components used:

- Integrating sphere
- 405 nm LED
- 470 nm LED
- Optical fibers
- LED power source
- Spectrometer
- Glass vial with sample
- Fiber adaptor

The first part was to test the blue LED using the integrating sphere. This integrating sphere has two fiber inputs, one for the LED and the other to output the fluorescence. After putting the LED into the power source, we attached the fiber adaptor end and connected it to the integrating sphere. Then, attaching the other fiber into the second end on the integrating sphere and that to the spectrometer, we then put in the sample into the integrating sphere. As expected, the peaks were close together but there was only a small peak difference. The next step was to change out the LED for the 405 nm one. After switching out the LEDs we noticed the power level on the spectrometer was so low and the integration time was too low. We adjusted the max Y parameters and scaled up the integration time and we noticed that there was a much larger peak difference than the blue LED as the peak of the UV LED was extremely low. After the initial test it was confirmed that a UV LED is a far better choice than a blue LED. We decided to take the sample out and do some further testing outside of the integrating sphere. Instead of suing the integrating sphere as a reflective light source, we decided to try and just use the fibers onto the sample in line with each other. Continuing to use



the 405 nm LED, we used one end of the fiber and put it up against the glass vial. On the direct other side of the glass vial, we put the fiber connected to the spectrometer. Turning on the LED we noticed that the LED light extends further through material. This is due to the absorbance of the UV LED compared to the blue LED. The 470 nm LED would not work with an inline setup because the material absorbs too much and therefore it is surface emitting. The benefit of using a 405 nm LED is the less absorbance it has through the sample; this allows for the optical design to be more compact. We decided to add a filter in place between the spectrometer fiber and the vial. We used a sample long pass 450 nm filter and it completely blocked out the 405 nm. This allows the filter to be curved across the sample, this is the need for a curved filter. Because Everix filters are so thin, this allows them to be curved in any way and in this case would eliminate a lot of space in the optical design and would much more compact. One component that needs to be added is a collimating lens for the LED. To limit the non-normal angles through the sample, it is best to collimate the LED so the light that hits the filter will be completely reflected. To account for the limit of detection, we tested a much more diluted sample than the original. After diluting the sample, we noticed that although the fluorescence was decreased in its peak, there was far more LED leakage than the original sample. To counter this, an OD 6 filter would need to be in place that will completely block the UV light from entering the detector.

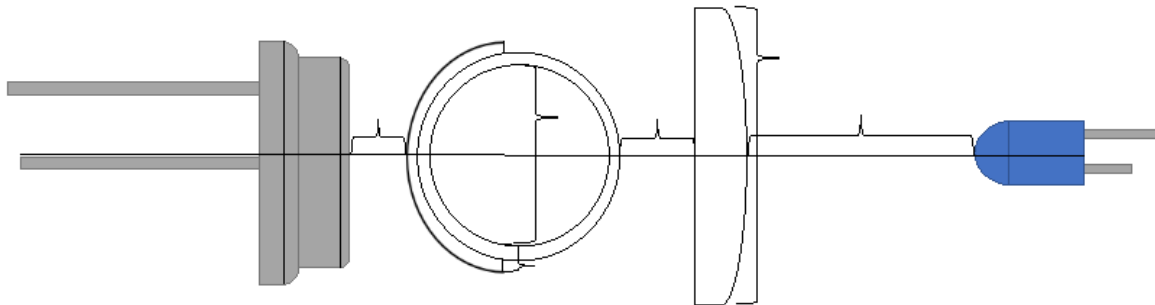
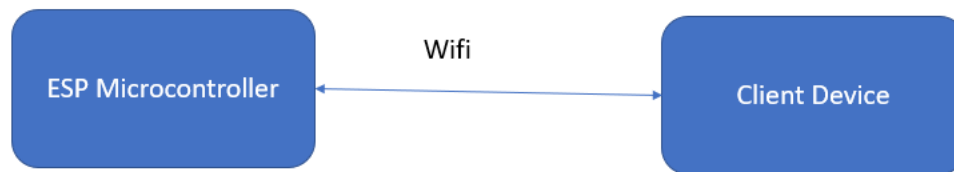

Figure 50 Case 2 optical design schematic

## 5.4 Software Design

### 5.4.1 Software Implementation

The software will be written using Arduino IDE and compiled for esp platform. The primary components of the software will be a SPI driver to communicate with the ADC, a websocket server, interrupts to service buttons, a screen interface using I2C or SPI, and a section for writing to the flash module built into the microcontroller. The interface between the client and device is very simple. It will only be the device, and the client communicating over a duplex wifi connection. The details of the software implementation will be explained in the following sections.



*Figure 51 Block Diagram of Microcontroller and Web Client*

#### **5.4.1.1 Microcontroller**

The ESP microcontroller will be the heart of the project. With its built in Wi-Fi Transceiver, it will handle all aspects of the software. These aspects are: controlling LED PWM signal, interfacing with the ADC to read photodiode values, interfacing with the display, servicing physical buttons, handling Wi-Fi communication via onboard Wi-Fi transceiver, hosting http server for web interface, storing and reading values from memory, and monitoring battery level.

#### **5.4.1.2 LED Driver Interface**

The Microcontroller will send a PWM signal to the LED to drive it at a specific brightness level depending on what the user has defined in scan profile. This PWM signal will consistently shine the LED at specific and repeatable brightness levels in order to receive consistent readings from the photodiode. This PWM signal will require one digital output from the microcontroller. The Microcontroller will also be responsible for turning on and off the signal with specific timing determined in the scan profile.

#### **5.4.1.3 The Analog to Digital Converter**

A high-resolution Analog to Digital Converter is paramount to the accuracy of this project. For this purpose, an external ADC such as the ADS1115 chip will be used. Chips like this feature 16 bit or higher resolution, and a SPI interface. The microcontroller will interface with the ADC over this SPI interface to collect voltage level to be converted into fluorescence value. The ADC built into most microcontrollers feature 10-bit resolution. This allows  $2^{10}$  or 1024 quantized voltage levels. This level of resolution would give us the ability to read 4 mV differences in the signal, which may not be enough to accurately detect the fluorescence. For this reason, something with 16 bits or higher will be used. This will have 65536 unique quantization levels, allowing for precision in the microvolts. This or greater number of bits of precision will be enough precision to make our readings accurately. The ADC module will transmit the quantized value to the microcontroller so it can calculate the result.

#### **5.4.1.4 Display**

A small display with a Serial Interface will be built into the device to allow the user limited functional use of the device without the web interface. This small display will need to be driven by the microcontroller. Using a Display Library, the microcontroller will process the display output and send over I2C bus, and be shown on the display. The microcontroller will not need to devote too many resources to this process because the display does not to be updated frequently and primarily will be showing a static image until a navigation action is done with the button or web interface.

#### **5.4.1.5 Buttons**

The microcontroller will use interrupts or poll the action button to detect short and long presses. This will allow the user to interact with the device and trigger different things. The Microcontroller interrupt will be looking for a rising edge on the digital input pin, and record the time between the rising and falling edge, as well as include software to debounce the button so that it doesn't register a single keypress as multiple keypresses.

#### **5.4.1.6 Wi-Fi Communication**

Using standard Wi-Fi libraries, the device will be able to broadcast a network as well as connect to an existing network as a client. This Wi-Fi communication is all done directly by the microcontroller using its built-in transceiver. The Wi-Fi library will handle broadcasting an SSID for the client to connect to, and if the user wants to, will handle connecting to an existing SSID and getting an IP address. The bulk of the work of Wi-Fi protocols will be handled by the microcontroller itself, and its standard libraries. Using the Socket library, a socket will be defined on port 80 for the Client to connect to, and the libraries will handle converting the data into packets and sending over the air between the device and the client.

#### **5.4.1.7 Web Socket Server**

The Microcontroller will establish a web socket server for clients to connect to. This server will implement standard http protocols and be compatible with all modern web browsers. The Microcontroller will only support one simultaneous socket connection and will not be controllable by multiple clients at once. The socket will remain connected to one client until the client disconnects making it available again. The server shall have a default IP address when in SSID broadcast mode, and will negotiate a DHCP address and display it to user when in WiFi client mode, connecting to an existing SSID. The Web socket will allow asynchronous data transfer between the client and the device so the device can broadcast to the client without a get request, and the client can send to the device without a get request. This will make the web interface very smooth to operate and less like filling out forms and submitting them.

### **5.4.1.8 Flash Memory**

The microcontroller will be responsible for interfacing with a flash module whether built into the controller, or external to the controller for storing samples and profiles. The samples and profiles will have predefined data structures so they can be stored to and read from the memory module for added convenience when using the device. The microcontroller will also be responsible for keeping track of the number of profiles and samples stored in the memory, so it can read them correctly from the memory.

### **5.4.1.9 Battery Management**

With a focus on consistency of samples, it will be very important to ensure enough voltage is available for illuminating the sample. The Microcontroller will be responsible for monitoring the battery level, and alerting the user when the device can no longer take accurate readings. This will also protect the battery from overuse, along with the undervoltage protection in the circuitry.

### **5.4.1.10 Client Software**

As the client is to be run in a web browser it will be written using HTML and Javascript, and server directly from the device which will be running a webserver. The web browser will handle the http and Web Socket protocols required for the Javascript to communicate with the Server running from the Arduino code programmed on the microcontroller. The Javascript will declare and use a standard Web Socket to communicate with the Device. Only one client will be able to simultaneously connect. Any other Client will be served a basic HTML page saying that the device is currently in use.

## **5.4.2 User Interface**

A simple yet feature rich user interface is crucial to the success of any project. For this reason, the device will have some onboard control, and a small screen for doing basic operations, but also broadcast a wifi network, and provide a web interface that allows for sample detection and saving, as well as device configuration via any wifi connected device with a web browser. This allows for the device to be cross-platform, functioning on Mac OS, Windows, Linux, Android, and IOS without the hassle of developing multiple applications. By making the device very simple to use, it will increase adoption, as nobody wants to use something with a clunky interface.

### **5.4.2.1 On-Device Controls**

#### **5.4.2.1.1 Home Screen in Client Mode**

The Device will feature a power button, and a start button. Upon pressing the power button, the device will turn on, upon start up if the device is in Wi-Fi Client mode it will

attempt to connect to the configured network, and if it is successful, the SSID and IP will be shown so a client can be connected. Until a client connects the current profile, and an indication that the device is ready to start a scan will be on the screen.



SSID: Demo IP: 192.168.1.3  
Pro: UserProfile1 Press Start  
Filter: 440-455NM to scan

*Figure 52 On Device Startup Screen Client Mode*

#### **5.4.2.1.2 Home Screen in Broadcast mode**

If the device fails to connect to the Client Wi-Fi Network or is in broadcast mode it will start broadcasting its own network and the screen will instead show the SSID, Password, and IP address to connect client device to.



SSID: Demo PW:1234 IP: 192.168.1.3  
Pro: UserProfile1 Press Start  
Filter: 440-455NM to scan

*Figure 53 On Device Startup Screen in Wi-Fi Broadcast mode*

#### **5.4.2.1.3 Profile Selection Screen**

By pressing and holding the control button, the Device will go into profile mode and allow the user to toggle through profiles by clicking the button, and pressing and holding the button to return to the main screen.

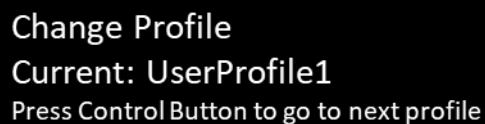

Change Profile  
Current: UserProfile1  
Press Control Button to go to next profile

*Figure 54 On Device Profile Change Screen*

#### **5.4.2.1.4 Scan Mode**

On the home screen, if the user clicks the command button, the device will begin taking the reading. And the screen will show a progress bar to indicate how long it will take to complete.



*Figure 55 Scan in Progress*

#### **5.4.2.1.5 Client Mode**

After a scan is completed, the reading will be shown on the display if no web client is connected. If a web client does connect, local control becomes unavailable. The display will show a message to warn the user of this. Stating that the device is currently under remote control, and to disconnect the client to resume local control.

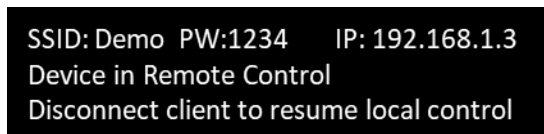

*Figure 56 On Device In remote control Screen*

#### **5.4.2.2 Web Control**

##### **5.4.2.2.1 Home Screen**

After connecting to the WiFi network, the web page will be available to the user. The home page will have quick controls for the user. These will include a profile selection dropdown, to choose between different configurations. The configuration options will be defined in the description of the configuration page. The home screen will also contain a button to initiate a scan, and a text field to hold the result. The home screen shall also have a menu button to view different configuration options. The home screen will contain dropdown boxes to select the profile and filter. The filter will be automatically populated from loaded profile, but the filter can be overridden from the profile by selecting it.

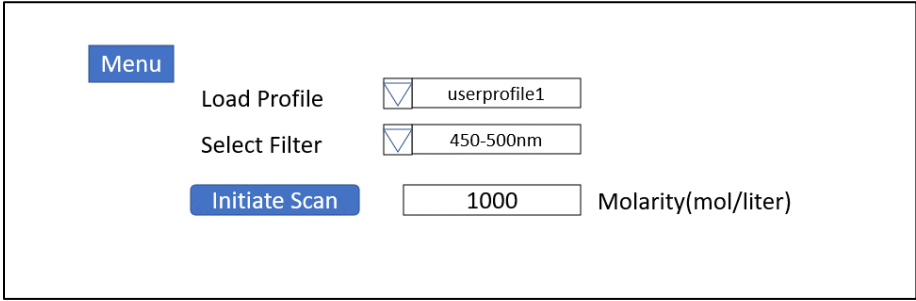

Figure 57: Example Home Screen for Web Interface

### 5.4.2.2.2 Scan in Progress Graphic

Pressing the initiate scan button, will trigger a graphic to show that a scan is in progress, and when complete, the reading will show up in the Result Field. The device will store a predefined number of readings in the memory of the microcontroller and be available on the history page.

### 5.4.2.2.3 Menu

Upon pressing the menu button, a menu will be presented with options for configuration, history, and system. Clicking the different items will load the different screens. A menu is a feature that many people expect to see in a modern web application. This will be in a familiar location and be laid out in a standard manner.

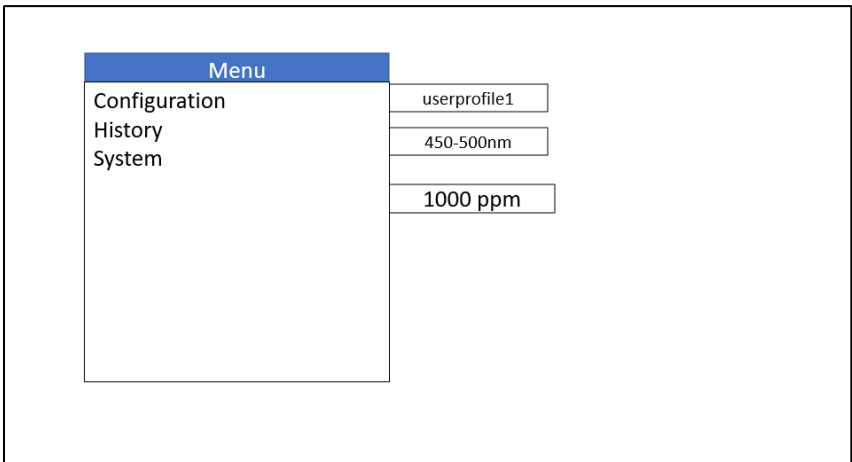

Figure 58 Example of Menu Screen

### 5.4.2.2.4 Configuration

Pressing the configuration button will bring up a menu page allowing the user to configure the scanning parameters of the device. This page will also be used to create user profiles.

The parameters that the user will be able to adjust are the profile, the sample delay, the Filter Type, the Number of Samples, the LED intensity, and the conversion ratio from Quantized light value to Molarity. This page will also allow the user to update the values in the selected profile and create a new profile. Pressing the button will prompt the user to name the new profile for recall from the home screen. This page will allow the user to create a predefined number of profiles and will have the ability to ship with default profiles. Depending on the implementation of filter switching, The Filter Types will either be fixed as they will be permanently installed in the device, or they will be user customizable if the user is able to add custom filters to the device as an end user. If the user is able to configure filters, they will also have that ability from this screen, but it is not shown in the example below.

The screenshot shows a configuration screen with the following elements:

- Configuration** (Title)
- Select Profile**: A dropdown menu with a downward arrow icon and the text "userprofile1".
- Sample Delay**: A text input field followed by the unit "ms".
- Filter Type**: A text input field.
- Number of Samples**: A text input field.
- Led Intensity**: A text input field followed by the unit "%".
- Concentration/Unit Light**: A text input field followed by the unit "Ratio".
- Update**: A button.
- Create New**: A button.

Figure 59 Example of Configuration Screen

### 5.4.2.2.5 History

From the menu, the user will be able to get to a Sample History screen where they can see past samples taken using the device. This allows the user to take multiple samples, and go back later to reference the sampled values. The device will store for each sample, the profile, a unique ID, the filter type, Molarity and the Raw Reading. The Raw reading is stored so that reading can be calibrated after the fact for maximum flexibility. This feature makes it very convenient for the user so they do not have to keep track of every sample from the device, and can track only the sample ID, and from the history, can find the scans they have done. This screen will also allow the user to export the samples to their computer so they can be analyzed in popular tools like excel to sort and group the data.



Profile	Sample ID	Filter	Molarity	Raw Reading

Figure 60 History Screen Example

**5.4.2.2.6 System Page**

The System configuration page will allow the user to configure the system settings of the device. This includes configuring the Wi-Fi settings. If the device is often used in one location, and portability is not a concern, the device can be put into wifi Client mode, and connected to an existing Wi-Fi SSID, by specifying the Wi-Fi SSID and password. In Client mode, the user does not have to disconnect from their Wi-Fi network, and can instead connect directly to the device by its IP address on the chosen SSID. In Access Point mode however, the device will act as a WiFi Access Point and broadcast an SSID for the client device to connect to. The user will also be able to specify the SSID to broadcast in this mode. This page could also allow for the possibility of OTA (over-the-air) updates to the devices firmware without the need for connecting to the microcontrollers serial port. By pressing the ota update button, the user will be prompted to upload the firmware file, and it will be loaded on the device. The system page will also contain some help documentation and basic instructions so that the User Manual is available anywhere the device is in use, and won't require an active internet connection to retrieve.

Configuration

WiFi Mode  Broadcast

Broadcast SSID

Client SSID to connect to

Client SSID Password

Figure 61 System Configuration Example

### 5.4.3 UML Class Diagram

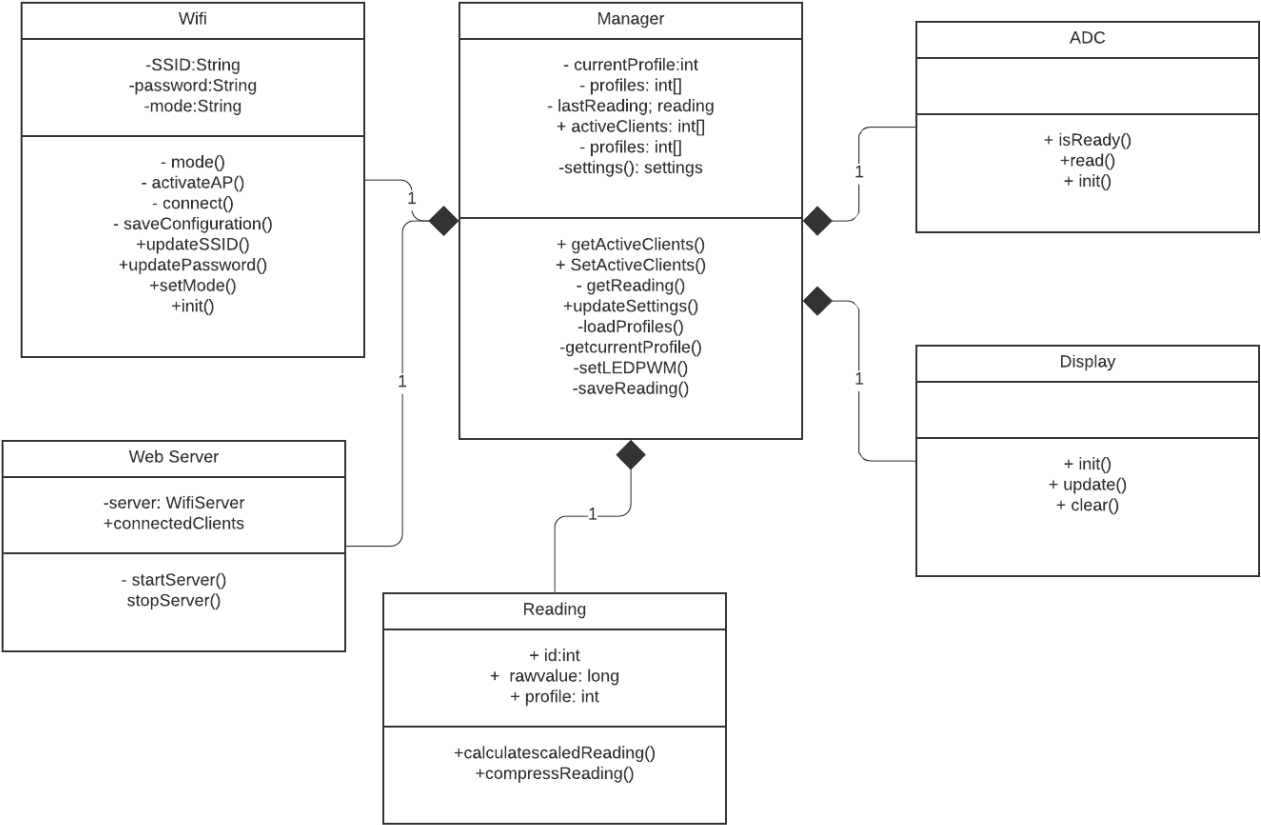

Figure 62 Software UML Diagram

#### 5.4.3.1 Class Diagram Overview

The software will be separated into different classes. The primary class will be the manager class. It will basically handle making calls to all the other classes to execute the needs of the device. It will be where the current profile, as well as the last reading, number of active clients, and settings will reside when the device is powered on. It will query most of this information from other modules.

#### 5.4.3.2 WiFi Class

The WiFi class will be responsible for maintaining and configuring wifi ap and client modes, and connecting to wifi network in client mode or broadcasting in AP mode. When the manager class calls `init()` on the wifi class, the wifi configuration will be passed to it by the manager class and the WiFi class will attempt to establish the connection defined in settings and report to manager class its status. The web server class will use the connection established by the wifi class to serve its web content.

### **5.4.3.3 Web Server Class**

The Web Server class will be one of the most important. It will be responsible for serving web files to client browser upon http request to the device's IP address. The web server class will create the socket connection to the client browser, and allow the user to operate the device, and send data back to the manager class that it can use to update settings, configure active profile, and start a reading. As well as all the other functionality of the Web UI described above. All this communication will be handled by the web server class.

### **5.4.3.4 Reading Class**

The reading class defines the datatype that will be used to hold the reading history in volatile memory while the device is running. The reading class defines the structure for holding the readings unique id, raw value from ADC and the profile that was used to take the reading. Because the user is able to modify existing profiles, the entire profile must be stored with each reading so that the scaled value can be calculated for each reading. The class has a function to calculate the scaled reading from the raw voltage input stored in the sample. This allows flexibility and for some aspects of sample profiles to be modified after the fact, just not things like the led brightness as this is done during the scan, and is not related to a scaling formula.

### **5.4.3.5 ADC Class**

The ADC class will be responsible for maintaining I2C communication with the ADC. As well as triggering the ADC to read, setting the ADC configuration buffers to read samples the way that is required for the project. This class will also contain bias constants to adjust the sensor reading so that the photodiode can be calibrated to a known light intensity source. This will be crucial in the device getting accurate readings. The ADC class will also be responsible for waiting for the ADC reading to become available, and then retrieving using I2C the 18 bit word containing the quantized voltage level and conveying that back to the manager to include in the new sample. The ADC class will be queried for multiple readings per sample as configured in the device profile that is selected when the reading is started. The ADC will need to precisely trigger readings timed with the LED output so that we can accurately measure the fluorescent light generated at the correct moment when it is being excited.

### **5.4.3.6 Display Class**

The display class will be responsible for communicating with the display driver and sending it the information to be displayed on the screen. The manager will update the display class with the information that should be on the screen, and the display class will process the information and display it to the user. The display class will manage the SPI connection with the display driver chip built into the display we will be using.

## 5.5 Summary of Design

The Overall system will be able to excite fluorescent samples using an LED and the light will travel through the optical system to the photodiode. The electrical system will interpret the signal from the photodiode and give the software a raw voltage value for the reading. The device software will interpret the voltage and apply a user profile to the sample along with thresholding and averaging multiple subsamples to generate a molarity reading and present it on the display to the user. The electrical system will power the device, and a signal will be sent by the software to the LED driver and power will be applied to the LED and it will emit a specified amount of light. The light will travel to the sample and reflect into a planoconvex lens to collimate the light. After passing through the lens, the reflected LED light will then travel to a long-pass filter from Everix. The LED emission light will be cut off by the optical filter, only passing the emitted fluorescence from the sample. The photodiode will produce a photocurrent proportional to the fluorescent signal passing through the filter. The electrical system will drive an amplifier using the photocurrent and convert it into a voltage which can be converted using the ADC and sent to the microcontroller via I2C connection to be converted by the software to molarity reading.

## 6 Project Prototype Construction and Coding

### 6.1 Integrated Schematics

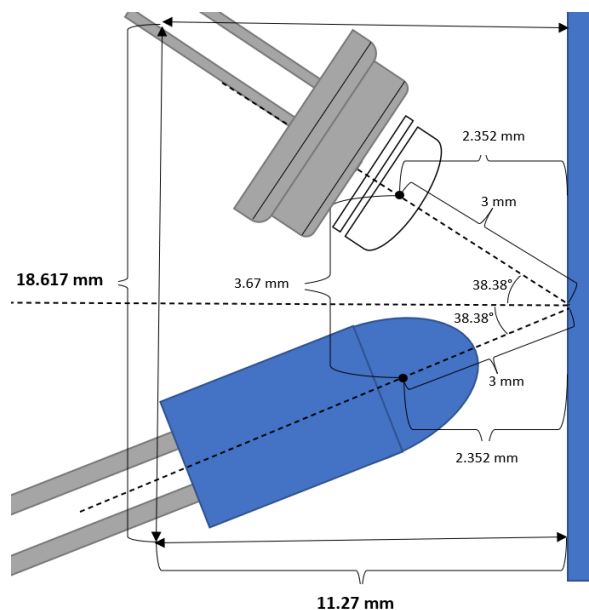

Figure 63 Optical Schematic Diagram

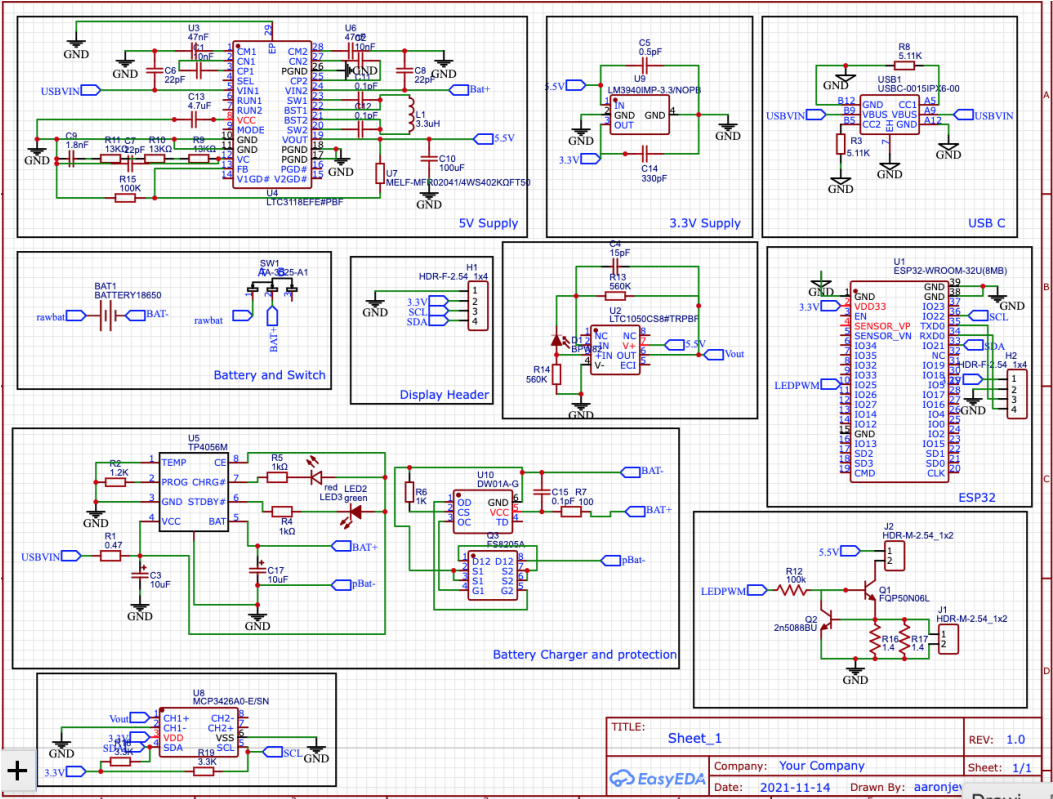

Figure 64 Electrical Schematic Diagram

### 6.2 PCB Vendor and Assembly

The PCB will be produced by JLCPCB, and most of the smt assembly will also be done by JLCPCB. The team will solder all components not soldered by JLCPCB. Components not in JLCPCB Catalog will be sourced from. JLCPCB was chosen due to their integration with easyEDA, the schematic software we used to create our schematic. Also, because they offer SMT assembly and part picking, at a very affordable price good for a one off project like this.

### 6.3 Prototype Construction

The Prototype will consist of the optical components, the electrical components, and the software. The PCB will be given to us with most SMT assembly completed, so we will need to solder a few components that were thru hole, or not in the vendor library. A solder reflow oven may be needed for smt assembly, however this will be avoided if possible since we will have to reflow components that have already been placed and risk messing that up. The PCB and optical components will be assembled in the enclosure, and then the testing will begin. Alignment of the LED and Photodiode with the optical components will be very important for this project, so those two components will likely be mounted

freely with wires connecting them to the PCB. After assembling the optical and electrical components a battery can be added, the software can be flashed onto the ESP32 chip. This will be the completed Prototype.

### ***6.3.1 Prototype Lens Holder***

The Inner Single Mount is the lens mount which we have chosen out of the three holders for integration into the construction of our prototype device. What sets the Inner Single Mount above the other holder considerations is a price of \$16 on sale from a previous \$28.00, having no outer diameter reduces the extra material we would need to cut, and a total holder length of 9 mm. The price and dimensions of the Inner Single Mount are considerably smaller which means that it will both cost less to buy and require a smaller amount of material to be cut off of the mount in order for it to fit into our prototype enclosure's size.

## ***6.4 Final Coding Plan***

The software will be written in different independent modules. The modules will each be tested and then integrated together. There will be a module for the ADC, a module for the Display, a module for the LED driver, a module for the wifi, a module for the webserver, and all will integrate to make the complete software. The software will be primarily designed by Aaron with input from the rest of the team.

## ***7 Project Prototype Testing Plan***

Different types of testing are needed to guarantee that the task will meet up with some level of usefulness. Nothing at any point works totally the initial time around and should go through different tests to ensure each element is represented. The different equipment parts should be tried broadly, and all products should be composed to guarantee all ideal assignments are being performed. This part traces the arranged techniques and executions for equipment and programming testing for the venture. The extent of each testing stage is noted in table beneath.

Various kinds of testing are expected to ensure that the endeavor will get together with some degree of convenience. Nothing anytime works totally the underlying time around and should go through various tests to guarantee every part is addressed. The diverse gear parts ought to be attempted extensively, and all items ought to be created to ensure all ideal endeavors are being performed. This part graphs the organized procedures and executions for gear and programming testing for the endeavor. The degree of each testing stage is noted in

## **7.1 Electrical System Testing**

All electrical components shall be included in the schematic drawing and be constructed in Easy Eda in order to verify the integrity of the design and correct component design placement to create a more compact design. The smaller electrical components such as resistors and ICs will not be tested separately, this will cut down on the time required to start and keep the testing process fluent. Any of the needed voltage regulators or other comparative parts of the plan might be checked for fundamental usefulness upon examination after the undertaking has been collected.

### **7.1.1 PCB Testing**

To properly check the printed circuit board, we will hold the multimeter's test leads to test points on the board. Meanwhile only holding the plastic part of the probe with our hand while performing this step. Then you can move on to checking the voltage or resistance. In order to test the photodiode works first we will just plug it into a mA multimeter and shine a light on it. For the photo diodes, the power output must be between 0.2 and 0.5 mA/mW. In order to test the overall circuit, we will measure the voltage on the power rail with a multimeter. Both the input and output of the voltage regulator should show the expected value. Check the fuse if the input voltage measured by the voltage regulator is 0V. Make sure no components are at risk of shorting. An output voltage below 0V or  $V_{cc}$  often means a short circuit has occurred in the regulator or component on the voltage rail. In this case, the damaged component heats up quickly. I/O is also a common point of failure. Damage to an I/O port rarely blocks an entire circuit, but usually causes system anomalies. For example, an alarm controller that detects that a door is always open even when it is closed, or an engine that is continuously activated. Furthermore, we will have to add the display we chose and see

#### **7.1.1.1 Power Testing**

The system contains two power regulators. The first step in power testing will be to verify that the correct rail voltages are achieved for 3.3 and 5v rails, and that the regulators can push the expected amount of current. The LTC3118 regulator has two voltage input sources so the regulators ability to produce 5v from either the 5v usb input, or the lithium battery as input will be tested by connecting a power supply to the battery terminals with the usb disconnected. The power supply voltage will be set to the lower and upper limits of the battery voltage, and the regulator will be loaded to verify it can sink the necessary current. Based on preliminary calculations, the circuit will need less than 850mA when the led is on, so as long as the regulator can handle 5v and 850mA the circuit will be receiving the proper 5v power. The 3.3v regulator is downstream of the 5v regulator, and once the 5v regulator has been verified, the 3.3v regulator can also be verified. Based on preliminary calculations, the system will use less than 400mA of current from the 3.3v regulator to power the mcu, adc, display, and photodiode amplifier. The power switch will

also be tested. The battery will be fully disconnected if the switch is in the off position, and connected if the switch is in the on position. This allows the battery to be isolated from the system and provides the user a way to turn the device on and off.

### **7.1.1.1.1 Power Regulator Testing**

As described above, the Voltage regulators will be tested using the procedure below. It is important to validate the rail voltages produces, and the current capabilities of each regulator to make sure there is ample headroom and the regulators will not be brought beyond their limit

#### **7.1.1.1.1 Power Regulator Testing Procedure**

Step	Description	Action	Expected Results
1	Preparation	Prepare 2 power supplies, 1 standard usb 5V power supply with USB C cable, one benchtop supply with an output of 3.7V 2a at least, multimeter with current capability, and an electronic load.	
2	Preparation	Connect the 5V supply to the usb input of the device, and the benchtop supply to the battery tabs on the device to simulate a battery. A real battery will only be used once battery circuit testing is complete, and the use of a power supply will allow the team to characterize the current draw on the battery.	
3	Test primary Power Regulator voltage output on usb power	Use multimeter to test voltage at output of primary regulator	Verify voltage is 5V
4	Test power switchover	Turn on benchtop supply output with voltage at 3.7V	Verify rail voltage is still 5V
5	Test primary Power Regulator voltage output on battery power	Disconnect usb supply so device is only powered by benchtop supply.	Verify rail voltage is still 5V



6	Test power output of primary regulator	Reconnect usb supply and turn off battery supply. Connect electronic load to the output of the primary regulator and turn on at 5V. Slowly ramp the current to 800mA	Verify that the regulator provides a consistent 5 Volt output, and is able to safely sink 800mA of current without overheating
7	Test Voltage output of secondary 3.3V regulator	Connect volt meter to output of secondary regulator	Verify there is a steady 3.3V output with meter connected here.
8	Test power output of secondary 3.3V regulator	Transfer electronic load to the output of the secondary regulator. Set electronic load to 3.3V and Slowly ramp the current to 400mA	Verify that the regulator provides a consistent 3.3 Volt output, and is able to safely sink 800mA of current without overheating
9	Test regulator on battery supply	Repeat steps 5, 6 ,7 , and 8 with the usb disconnected and the battery supply turned on	Verify all regulator voltages and currents are achieved when device is running on battery power.

*Table 12 Power Regulator Testing Procedure*

### **7.1.1.1.2 Power Switch and USB Testing**

Two of the most critical power functions of the device are the ability to disconnect the battery using the switch, and the ability to charge and operate the device using the 5V input from the usb.

#### **7.1.1.1.2.1 Power Switch and USB Testing Procedure**

Step	Description	Action	Expected Results
1	Preparation	Gather Required Equipment: Assembled PCB, multimeter with resistance measurement, current, and dc voltage measurement capability, 5V usb power supply, and usb type C cable	

2	Test usb input	Connect usb power supply to wall, and usb C cable to device.	Verify 5V input on usb receptacle, and verify 5V on 5V output of power regulator.
3	Test Battery Switch Functionality	Flip power switch	Verify continuity or non continuity in this state of the power switch
4	Test Battery Switch Functionality	Flip power switch other way	Verify continuity or non continuity in this state of the power switch is opposite to state in step 3

*Table 13 Power Switch and USB Testing Procedure*

### **7.1.1.1.3 Battery Protection Testing**

The DW01 chip will need to be verified works correctly. This can be done by testing all the protection cases, so shorting the output of the DW01 to create a short circuit, and simulating battery overcharge, overdischarge, and overcurrent conditions. The DW01 should disconnect the battery if the battery is charged beyond its safe point, disconnect if the voltage goes below the overdischarge voltage, and disconnect if too much current is drawn from the battery.

#### **7.1.1.1.3.1 Battery Protection Testing Procedure**

Step	Description	Action	Expected Results
1	Test Preparation	Gather Required Equipment: Assembled PCB, multimeter with resistance measurement and dc voltage measurement capability, DC Power Supply with adjustable voltage output, power leads with clips for attaching to battery leads. Wire to test short circuit protection, Electronic Load or load resistor	
2	Test battery reverse polarity protection	Test Battery reverse polarity protection by connecting the power supply leads backwards. Negative to positive, positive to negative. Set power supply voltage to 3.7V and current to 0, and slowly increase current to 10 mA. Battery protection circuitry should disconnect the	Using multimeter, verify there is no continuity between protected battery ground on board, and battery ground tab.

		battery – tab from the circuit pBat-trace. Electrically isolating the battery.	
3	Verify continuity reset after reverse polarity scenario	Connect Power supply leads in the correct polarity and turn on power supply at 3.7V	Verify that the continuity is restored between battery – tab and pbat- trace.
4	Test Short Circuit Protection	Connect Power supply leads in the correct polarity and turn on power supply at 3.7V. Use a wire to short pbat – to batt +.	Verify there is no continuity between batt- and pbat -.
5	Verify continuity reset after short circuit scenario	Connect Power supply leads in the correct polarity and turn on power supply at 3.7V. Remove wire used to short battery. Cycle power output on power supply to reset the protection circuit.	Verify that the continuity is restored between battery – tab and pbat- trace.
6	Test Overcharge protection	Increase power supply to 4.4V to simulate overcharged battery	Verify that there is no continuity between pbat- and Batt- tab indicating the protection circuit has been activated.
7	Verify continuity reset after short circuit scenario	Connect Power supply leads in the correct polarity and turn on power supply at 3.7V. Remove wire used to short battery. Cycle power output on power supply to reset the protection circuit.	Verify that the continuity is restored between battery – tab and pbat- trace.
8	Test Overdischarge Protection	Connect Power supply leads in the correct polarity and turn on power supply at 3.7V. Decrease power supply voltage to 2.5V	Verify that there is no continuity between pbat- and Batt- tab indicating the protection circuit has been activated.
8	Verify continuity reset after overdischarge scenario	Connect Power supply leads in the correct polarity and turn on power supply at 3.7V. Cycle power output on power supply to reset the protection circuit.	Verify that the continuity is restored between battery – tab and pbat- trace.

9	Test Overcurrent Protection	Connect Power supply leads in the correct polarity and turn on power supply at 3.7V. set current output to 500mA. Connect load to pbat- and Batt+ and draw more than the rated current.	Verify that there is no continuity between pbat- and Batt- tab indicating the protection circuit has been activated.
8	Verify continuity reset after over current scenario	Connect Power supply leads in the correct polarity and turn on power supply at 3.7V. Cycle power output on power supply to reset the protection circuit.	Verify that the continuity is restored between battery – tab and pbat- trace.

*Table 14 Battery Protection Testing Procedure*

#### **7.1.1.1.4 Battery Charger Testing**

The TP4056 charge controller will need to be verified is wired and working correctly. This can be simulated by connecting a voltage source to simulate the battery. The voltage source setpoint can be lowered to the charge range of the charger. Then the indicator leds can be verified match the charging state. Then the voltage setpoint can be raised to simulate a charging battery, and when the charge voltage is reached, the charger should be observed shutting off the charge power to the battery. The charge current should also be verified by setting supply voltage to a depleted battery and verifying that the configured charging current is being put into the battery.

##### **7.1.1.1.4.1 Battery Charger Testing Procedure**

Step	Description	Action	Expected Results
1	Test Preparation	Gather Required Equipment: Assembled PCB, multimeter with resistance measurement, current, and dc voltage measurement capability, DC Power Supply with adjustable voltage output. 5V usb power supply and usb type C cable	
2	Test battery charging	Set power supply voltage to 3.5V to simulate a discharged battery. Connect USB power to usb C power. Measure voltage between batt+ and batt- tabs.	Verify that correct charge voltage is observed, and that correct led's are present for charging state.

3	Test battery charge current	Connect current probe, while simulated battery is in the charging state.	Verify current output from battery charge matches designed charge current of 300mA
4	Test end of charge	Increase power supply to 4.2V to simulate battery being fully charged	Verify that the charging indication leds show standby state, and the charge circuit is not applying current to the simulated battery.

*Table 15 Battery Charger Testing Procedure*

### **7.1.1.2 Photodiode Testing**

The photodiode and amplifier circuit will also need to be tested so that the relationship between light intensity and output voltage can be calculated and included in the software as a scaling factor. A light source with a known intensity in the expected level for our device will be shone directly into the photodiode, and the voltage will be read from the output of the amplifier. By following this process with multiple light intensity levels, a scaling function depending on the linearity of the scaling can be applied to the raw output of the sensor. Then the device will have to be calibrated to the actual fluorescent samples. So, samples with known quantities of fluorescent material will be excited and measured to create a scaling ratio or function depending on the linearity to convert from raw voltage reading to molarity of fluorescence concentration. This calibration will be discussed in another section, but will be an important part of device testing and development.

#### **7.1.1.2.1 Photodiode Testing Procedure**

Step	Description	Action	Expected Results
1	Preparation	Gather Required Equipment: Assembled PCB, current measurement multimeter. Bright light. USB Power Supply and usb type C cable.	
2	Preparation	Connect photodiode to multimeter probes	
3	Preparation	Verify multimeter probe is connected in current mode, and the meter is in current mode	

4	Test photodiode output	Shine bright light at varying levels on the photodiode detector surface	Verify that a current is shown on the multimeter corresponding to the intensity of the light
5	Preparation	Connect photodiode to PCB	
6	Preparation	Connect multimeter to GND of PCB and Vout of op-amp for photodiode amplifier. Configure meter to measure DC volts	
7	Test Photodiode amplifier	Shine bright light at varying levels on the surface of the photodiode.	Amplifier output should go from 0-5V with 5v being the brightest possible light, may not be achievable, but should be a meaningful voltage difference between no light, and high intensity light.

Table 16 Photodiode Testing Procedure

### 7.1.1.3 Wi-Fi Testing

Because the microcontroller has an FCC approved transmitter, there is not any stringent RF testing that needs to be done to ensure the safety of the Wi-Fi Transmission, however some testing will have to be done to ensure proper bandwidth and range capabilities for using the device, and also that it can be connected to a Wi-Fi network successfully.

#### 7.1.1.3.1 WiFi Testing Procedure

Step	Description	Action	Expected Results
1	Gather Equipment	Wifi Router, Device capable of connect to wifi Access Point (eg: cell phone), device	
2	Load Testing Software on Device	A special firmware will be developed for wifi testing. The firmware will only have some testing sequences in it for wifi testing, not for controlling the other hardware.	

3	Test WiFi Client Mode	Configure firmware to SSID and password of wifi router, and initialize wifi.	Verify that a successful connection can be made> The device's internal web server should serve a simple webpage to verify data transfer.
4	AP Mode Test Preparation	Configure firmware to AP mode and set an SSID and password that will not conflict with any in the area	
5	AP Mode Test	Attempt to connect the devices broadcasted SSID.	Upon successful connection, the device's internal web server should serve a simple webpage to verify data transfer.

*Table 17 WiFi Testing Procedure*

#### **7.1.1.4 LED Driver Testing**

The PWM LED Driver will need to be tested to verify it can provide enough current to the led without overloading it, and that it can successfully turn the led on and off, and dim the LED. The Current will be monitored going through the LED to verify the current delivered to the LED that we designed for can be delivered to the LED and the LED does not have adverse effects. A potentiometer can be attached to the circuit for tuning the output current, and a suitable resistor can be added to closer match the led current to the desired led current.

##### **7.1.1.4.1 LED Driver Testing Procedure**

Step	Description	Action	Expected Results
1	Preparation	Gather a usb 5v supply and usb c cable, the LED, a potentiometer, a multimeter with current sensing, the PCB, a jumper wire, and a light detection device, and a 3.3V supply	
2	Preparation	Use the jumper wire to eliminate the LED from the circuit for tuning, and connect the potentiometer. Connect the current meter in series with the jumper wire. Set the	

		potentiometer as high as possible to start so it will not affect the resistance of the initially selected resistor. Connect the 3.3V supply to the PWM input of the Led Driver circuit to enable the driver to full on	
3	Current Tuning	Plug in the USB supply, and the current measured by the meter should be about 300mA. Use the potentiometer to increase or increase the current if it is too low. If it is too high, the original resistor will have to be removed, then the potentiometer can be used solely, and raised or lowered to get the desired current.	When finished, verify the current measurement is as close as possible to 300 mA
4	Measure Resistance	Use multimeter to measure the resistance of the resistor system, and size a resistor of the same value, or two resistors to achieve the desired current value and install onto the board	
5	Connect LED	Disconnect USB and Replace the jumper wire with the LED	
6	Test LED	Plug in USB	Verify LED turns on
7	Characterize current draw	Measure the current when the LED is emitting	Verify the current is within limits for the led safe operation, and verify that the current reading matches the tuned value from step 3
8	Verify LED safety	Run the LED for a while to verify there is no degradation and it is operating within limits	The LED should operate continuously with consistent brightness without breaking
9	Preparation	Connect LED PWM input to microcontroller and load LED testing firmware with manual control of led PWM	
10	Test LED PWM	Set PWM to 0	Verify that no light is being emitted by the LED



11	Test LED PWM	Slowly ramp up PWM duty cycle to 100%	Verify that the led increases in brightness as the PWM signal is ramped up.
----	--------------	---------------------------------------	---

Table 18 LED Driver Testing Procedure

### 7.1.2 Photodiode Calibration Testing

Step	Description	Action	Expected Results
1	Determine the conversion factor between the concentration of fluorophores in a sample and the amplified photocurrent signal within our overall prototype device.	Our prototype device will be placed at a fixed distance away from the sample container while the sample fluorescein concentrations will vary from 5 nM to 5 pM concentrations. The detection will be measured based on a multimeter connection placed after the photocurrent signal is amplified in the surrounding circuit. The output measured current will be plotted and analyzed with respect to each concentration of fluorophores within solutions to obtain a conversion factor or conversion curve.	We expect to see a linear conversion curve relating to increasing photocurrent as concentrations of fluorescein within solutions are increased.

Table 19 Conversion factor testing procedure

## 7.2 Software Testing

### 7.2.1 Local HMI Testing

#### 7.2.1.1 Device Power Up

When the device is first turned on, it will be tested to make sure the device boots to the correct menu screen with the correct profile loaded, and the WiFi settings match what is configured in settings. The device will default to being in local control mode upon boot and stay in this mode until the web client connection is activated. For local control testing, no client will be connected to the device.

**7.2.1.1.1 Device Power Up Testing**

Step	Description	Action	Expected Results
1	Preparation	Gather the device	
2	Preparation	Insert Battery into device	
3	Test Power Up	Flip Device power switch to ON position	Verify the display turns on once the device boots, and shows a menu screen. The device should show wifi connection information, profile information, and say press start to initiate scan. Note: In Wifi Client Mode the device will show slightly different information on the screen, but this step passes if the device powers on and shows local hmi information with no connected client.
4	Test Power Off	Flip Device Power switch to ON position	

*Table 20 Device Power Up Testing*

**7.2.1.2 Navigational Functionality**

When the device is turned on, the user has limited operational capabilities with the device. They will be able to either press the action button or long press the action button. Verify that pressing the action button triggers the device to take a reading. Then verify that long pressing the action button results in the device navigating to the profile selection screen. From this screen verify that pressing the action button cycles through the profiles stored within the device. After cycling to a different profile, verify that long-pressing the action button returns the device to the main screen showing the newly selected profile. Finally connect a web client and confirm that the screen shows that the device is in web control and to disconnect from web control to return control to on-device controls.

### **7.2.1.2.1 Navigational Functionality Testing Procedure**

Step	Description	Conditions	Expected Results
1	Preparation	Power on the device	
2	Test short press of action button	Short press the action button once.	Verify that the device takes a reading using the correct profile, and that the reading is displayed on the screen after it has been taken and calculated.
3	Test Long press of action button	Long press the action button once.	Verify that the profile selection screen is displayed.
4	Test Profile Navigation	Short press the action button repeatedly while on the profile selection screen	Verify that the different profiles are being toggled through once per button press
5	Test profile selection	Long press the action button once while on the profile selection screen	Verify that the profile that is shown on the profile selection screen is now the selected profile on the main screen, and a sample taken will use the newly selected profile.

*Table 21 Navigation Functionality Testing Procedure*

## **7.2.2 Web Client Testing**

The web client has significantly increased control of the device so there is much more to test than the local HMI. Testing will cover all aspects of the web interface, and follow a logical flow through the HMI. The purpose of this testing is to verify that functionality of the software, and that all data is correctly passed back and forth from the Web GUI to the device backend.

### **7.2.2.1 Web Client Connection and Navigation**

Verify that the web client is able to connect to the device IP address and the home screen is loaded in the web browser. From the home screen verify that the web interface can navigate to each page and back to the home page. If every page successfully loads, the WiFi and Web Server classes are working correctly.

### 7.2.2.1.1 Web Client Connection and Navigation Testing Procedure

Step	Description	Conditions	Expected Results
1	Preparation	Power on the device, and Power on a router with a known password that the Device and its client can connect to.	Verify the device is in AP mode. If it is not, connect to the web client and configure the device to be in AP mode.
2	Test AP Mode Connection from client device	Connect Client Device to SSID broadcasted by the device	Verify that the client device can successfully connect to the sensing device WiFi access point
3	Test web server	Enter IP Address displayed on device screen into web browser and hit enter	Verify that the Web GUI is successfully loaded on the Client Device
4	Preparation	Configure the Device to be in Client mode, and set the SSID and Password to the SSID and Password of the testing router.	
5	Test Device connection to WiFi Router	Wait for the device to connect to the wifi router. If it does not successfully connect within a few attempts, it will be switched to AP mode.	Verify that the device has connected to the router by checking for an IP address on the screen of the device. The IP address will match the subnet of the router, and be different from the subnet of the AP created by the device in AP mode.
6	Test web server	Enter IP Address displayed on device screen into web browser and hit enter	Verify that the Web GUI is successfully loaded on the Client Device
7	Test Client Mode Failover to AP mode	From the web GUI configure the device to use an incorrect WiFi SSID and password that will fail to connect	Verify that after waiting a few seconds, the device begins to broadcast an SSID that can be connected to, and shows its IP address on the display

Table 22 Web Client Connection and Navigation Testing Procedure

### 7.2.2.2 Home Page

On the home page, verify that the user can select a profile using the profile dropdown, and initiate a reading, and when completed show the new reading to the user. Then restart the device and verify that the profile was saved to nonvolatile memory.

#### 7.2.2.2.1 Home Page Testing Procedure

Step	Description	Conditions	Expected Results
1	Preparation	Power on the device and connect to the web GUI	
2	Test Remote Scanning capability	Press the Initiate Scan button on Web GUI	Verify that the device initiates a scan
3	Test default profile memory	On web GUI select a different scan profile. Then turn the device off and on, and reconnect to the GUI	Verify the that newly selected profile has been loaded as the default profile.

Table 23 Home Page Testing Procedure

### 7.2.2.3 Configuration Page

Verify that the configuration page shows all expected profiles, and allows the user to edit a profile and save it to the device. Verify that each setting on the configuration page can be saved and correctly recalled for a profile.

#### 7.2.2.3.1 Configuration Page Testing Procedure

Step	Description	Conditions	Expected Results
1	Preparation	Power on the device and connect to the web GUI. Navigate to the configuration page under the menu in the sidebar	
2	Test Profile recall from memory	Press Profile dropdown to view stored profiles and select one.	The default profile should now be switched to this profile. Also verify that all expected profiles are shown in the profile dropdown.
3	Test Profile Editing	Edit all parameters of a profile and update the profile to store the new values. Then leave the page and come back to it	Verify that the newly added settings have been updated in the profile

4	Test profile Adding	Click create new profile and give it a unique name	Verify that the profile is created and all settings match the settings selected on the profile page before pressing create new
---	---------------------	--	--

*Table 24 Configuration Page Testing Procedure*

### **7.2.2.4 History Page**

Verify that the History page shows all saved samples, and take a few new readings from the main page and confirm they are added to the history page. Verify that the user can update the conversion for a sample to get a new calculated reading from the raw reading in a previously taken sample. Verify that a sample can be deleted from the history, and restart the device and confirm that changes to the samples are reflected on the history page after device restart.

#### **7.2.2.4.1 History Page Testing Procedure**

Step	Description	Conditions	Expected Results
1	Preparation	Power on the device and connect to the web GUI. Navigate to the history page under the menu. Be sure to take several readings before performing this test	
2	Test Reading Storage	Look at stored readings on the history page	Verify that the readings were stored and that they were stored correctly.

*Table 25 History Page Testing Procedure*

## **7.3 Optical Prototype Testing**

### **7.3.1 Methods of Testing**

#### **7.3.1.1 Ailment of Detection**

The ailment we will be using for the fluorescence sensing device is lyme disease. We will detect Lyme disease through the detection of Lyme disease-based antibodies. Fluorophores attach themselves to these antibodies and allow for their detection through excitation and fluorescent light emission. Fluorescein sodium salt is a type of fluorescent tracer used for antibody detection. The material will be in a powdered form kept at room temperature to avoid any potential hazards if heated or kept not at room temperature.

Because this material is a powder, masks will need to be worn while working with the material as well as gloves. Fluorescein sodium salt has a wide range between the excitation and emission wavelengths which are 460 nm for the excitation and 515 nm for the emission spectrum. There will be a specific wavelength and frequency of LED to allow for the ailment to fluoresce under the right conditions. We will be sampling many different concentrations of the sodium salt either as a powder form or as a solution in water with different concentrations.

### **7.3.1.2 Determining Limit of Detection (LOD)**

The following definitions and methods of determining limit of detection of a fluorescence detecting device come from an article titled “Tech Note: Limit of Detection for Fluorescence Spectroscopy” within the website Wasatch Photonics. Limit of detection is typically defined as the sample concentration at which the signal is equal to three times the noise level [12]. The standard for the limit of quantization (LOQ) requires the signal to be ten times the noise level [12]. Fluorescein is noted to be the most common fluorophore used in determining LOD and LOQ of a fluorescent measurement system [12]. High-end benchtop fluorimeters regularly report limit of detection based on fluorescein [12]. A typical high-end benchtop fluorimeter specifies a 0.5 pM LOD for fluorescein [12]. We intend to use fluorescein sodium salt prototype testing as well as determination of our device’s limit of detection. Fluorescein sodium salt typically has an excitation wavelength peak of 460nm and a fluorescence emission peak at a wavelength of 515nm. Tests to determine the limit of detection of our device will be conducted through, multiple measurements of each sample out of a range of samples solutions, with varying concentrations from 5 picomolar (pM) to 5 nanomolar (nM) of fluorescein [12].

### **7.3.1.3 Determining LED heat dissipation and excitation potential**

LED samples will be tested to compare light output vs heat output and power usage to determine an effective power and cooling solution to achieve project goals. This can be performed as a benchtop test with LED’s and a power supply. This testing will allow the power budget to be more accurately estimated, and a battery and power system selected.

### **7.3.1.4 Determining LED radiance**

$$(22) P_s = \pi^2 r_s^2 B_0$$

$$(23) B_0 = \frac{P_s}{\pi^2 r_s^2}$$

$B_0$  is the radiance along the normal to the radiating surface in units of  $W/m^2sr$ .  $P_s$  represents the total optical power emitted from the source area in equation 22 and 23. The radius of the source emitting area of an LED is represented by  $r_s$ . By measuring the power emitted from an LED and given the radius of the source emission area of the LED, the radiance of the LED can be calculated using equation 23. It is important

determination of LED radiance is important to the design of our device since our device uses blue LED light emissions which must be below a radiance of 10 mW/(cm<sup>2</sup>-sr) in order for our device to be considered safe. These measurements will be conducted in testing the LED emission light of our prototype device during normal operation.

### 7.3.1.5 Optical Design System Testing Procedures

Step	Description	Conditions	Expected Results
1	Determine the focal length of the plano-convex lens	The plano-convex lens is placed on a translation stage while light from a fiber illuminator is passed through a slit. After passing through the slit, light from the fiber illuminator will pass through the plano-convex lens and then will be reflected back through the lens then next to the slit opening. The distance between the lens and slit is equal to the focal length when the slit image reaches a minimum size.	The focal length of the plano-convex lens will be 6 mm which is the effective focal length given within the specifications for our chosen lens.
2	Ensure that the excitation light output from the LED is properly collimated	A beam block will be placed just short of the collimating lens, where the diameter of the light spot on the beam block will be measured and recorded with a ruler. This will be repeated with the beam block moved to successively farther distances away from the collimating lens	The calculated angular deviation between measured beam spot diameters will have a deviation angle of < 1° over a 1 ft total distance from the collimating lens
3	Ensure that excitation light is not leaking through the optical filter used in the fluorescence detection sub system.	The photodiode in the fluorescence detection optical sub system will be replaced with a spectrometer where the wavelength spectrum will be measured and recorded	The wavelength spectrum detected with the spectrometer will have a peak wavelength at plus or minus 5 nm from 515 nm with no secondary peaks in intensity at 460 nm representing excitation light reflected off the sample.
4	Determine the wavelength spectrum for	An optical setup using posts holding the sample fluorophore and excitation light source (LED) positioned so that the	The peak of the fluorescence spectrum will occur at



	the excitation light source and the fluorescence light emission	fluorescent light emission and excitation light spectrum will be measured by a spectrometer	a 515 nm wavelength with a margin of error of 5 nm. The peak of the excitation light from the LED will occur at a 460 nm wavelength with a 5 nm margin of error.
5	Determine the full and half viewing angles of the LED light emission	An optical setup using posts, a rotation stage, and a power meter. A small circuit consisting of a voltage source and resistor will be constructed to turn on the LED. The LED will be positioned at the center of the rotation stage and a power meter will be placed in front of the LED to measure output optical power. The LED will be rotated left and right, in one-degree increments, until the output optical power from the LED is no longer measured on the power meter.	With the LED centered at a starting angle of zero degrees with respect to the optical axis. The full viewing angle measured accounting for both left and right rotations will have a value of 16°. The half viewing angle value will be 8°
6	Determine radiance of the light emitted from the blue LED	The optical setup will include optical posts, an LED holder, small LED breadboard circuit, and a power meter. The LED will be placed in an optical post opposite to an optical post holding the power meter. The power meter will measure power output from the LED when the LED is set to the highest intensity as well as when the LED is set to for traditional operation of our device. These output power measurements will be used in equation # to calculate the LED output radiance.	The radiance of the LED emission will have a value below 10 mW/(cm <sup>2</sup> -sr) in order to comply with the blue light LED safety standard. If the highest operational intensity of the LED has a radiance value larger than 10 mW/(cm <sup>2</sup> -sr) than the LED must not operate at this intensity level under normal operations in order to comply with the blue LED safety standard.
7	Determine the fluorescence light output power of the	The optical setup will include an optical filter, optical posts, a power meter, LED, LED holder, and a small external circuit. The power meter will be placed in the same position as the photodiode is	The output power of the fluorophore concentrations will range from 0 to 5 mW

	fluorophore sample	placed within our design. The intensity of the light emitted by the LED will be varied from zero power up to the maximum output intensity of the LED. Multiple trials will be conducted with varied fluorophore concentrations from 5 nM to 5 pM at increments of 50pM.	
8	Determine LED rotation angle, with respect to the to a line through the normal of the sample container, where the optical filter cuts off the most excitation light and the largest fluorescent light peak will is seen	The optical setup includes the LED, thin optical filter, collimating lens, optical posts, lens and LED holders, and a spectrometer. The LED will be placed on a rotation stage at an angle from the sample container. The spectrometer will measure the spectrum of light passing through the collimating lens and optical filter at 5° angular incremental angles of rotation from 0° to 85°.	The spectrometer will measure a peak in intensity at a wavelength near to 520 nm. The fluorescent light intensity peak at around 520 nm will be larger than the excitation peak intensity at 474 nm plus or minus 5 nm.
9	Determine limit of detection for the optical system within our device	The optical setup will consist of the sample container, optical posts, blue LED, collimating lens, optical filter, and photodiode. All of these components will be setup at fixed distances and angles. In this test multiple sample concentrations will be excited and the fluorescence emission of each will be detected through use of a multimeter for measuring the photocurrent that the photodiode outputs into the external circuit. Sample concentrations will be varied from 5 nM to 5 pM at increments of 50pM.	The limit of detection for our optical system measured by the multimeter will be at a sample concentration of 5 picomolar plus or minus 3 picomolar.
10	Determine the overall limit of detection of	Our prototype device will be placed at a fixed distance away from the sample container while the sample fluorescein	The limit of detection for our prototype will be at a 5 picomolar

	our device including the complete detection system	concentrations will vary from 5 nM to 5 pM concentrations. The detection will be measured based on the limit at which the prototype can no longer detect and display a concentration of fluorescein solution on the prototype screen	concentration plus or minus 3 picomolar.
--	--	--	--

Table 26 Optical Design System Preliminary Testing Procedures

**7.3.1.6 Determination of the Fluorescence Spectrum Emitted by Fluorescein**

It was important for us to conduct some early testing on the fluorescein solution so that we could determine the fluorescein’s true peak fluorescence emission wavelength and spectrum. We needed to determine the peak fluorescence wavelength of our fluorescein solution early so that our sponsor Everix would have time to create thin optical filters for our device which would filter for our desired fluorescence wavelength and filter out a majority of the rest if the wavelengths of the EM spectrum. This allows Everix to begin the design and production process for the optical filters that we intend to use in the testing and demoing of our device in the second semester of senior design.

**7.3.1.7 Preliminary Testing: Fluorescence Spectrum Testing Procedure**

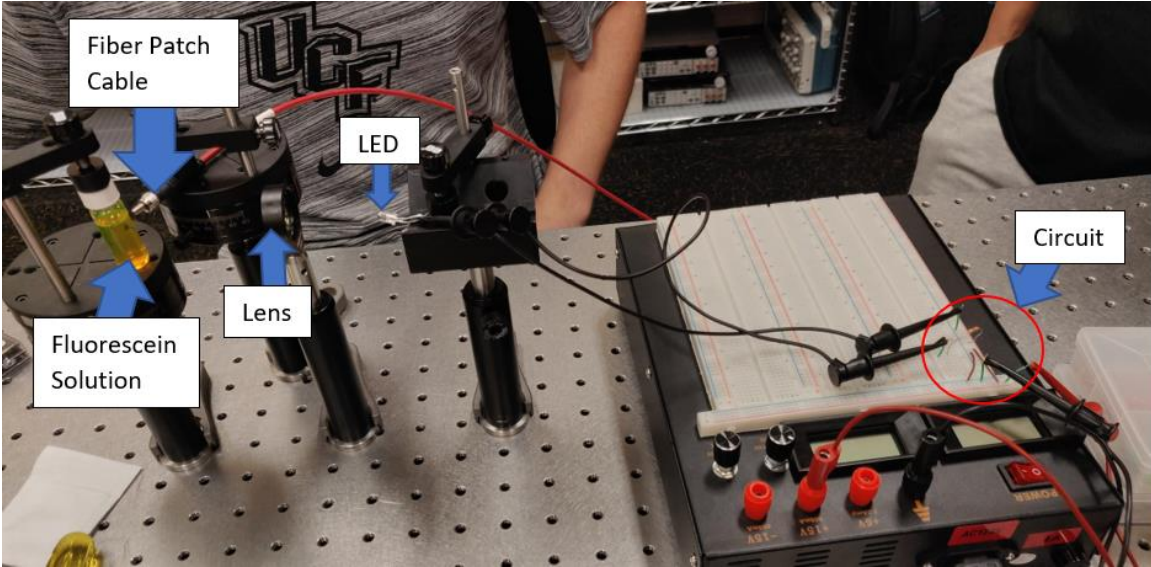

Figure 65 Fluorescein Fluorescence Spectrum Preliminary Testing

Description	Components	Condition	Expected Result
Determination of the true peak wavelength and spectral bandwidth of fluorescein's fluorescence emission light	<ul style="list-style-type: none"> <li>• Blue LED (465 nm peak)</li> <li>• fluorescein solution</li> <li>• glass container</li> <li>• optical posts (4x)</li> <li>• optical post holders (4x)</li> <li>• Plano-convex lens</li> <li>• Fiber patch cable</li> <li>• Spectrometer</li> <li>• Cable holder</li> <li>• Rotation stage holder (2x)</li> <li>• Breadboard w/ built-in power supply</li> <li>• 1 K<math>\Omega</math> Resistor</li> <li>• Wires (10x)</li> <li>• PC</li> </ul>	A spectrometer is used to detect the spectrum of fluorescence light emitted. A LED is used to enable the fluorescein solution to fluoresce. A lens is used to focus light onto the glass vial containing the fluorescein water solution. A small circuit was designed to turn on the LED and control the LED's output light intensity	The peak wavelength for fluorescein emission based on the online specifications of fluorescein occurs at a wavelength of 515 nm. The spectral wavelength bandwidth will taper off before reaching a wavelength of 460 nm.

Table 27 Preliminary Test Setup

### 7.3.1.8 Preliminary Testing Equipment Setup

In order to test the fluorescence emission of fluorescein we needed a source of light that is at the right excitation peak wavelength to cause the fluorescein to emit fluorescent light. We chose an LED which had a specified peak intensity at a wavelength of 465 nm which is very close to the 460 nm peak excitation wavelength needed for fluorescein. To apply a voltage bias on our LED we created a simple circuit which connected the blue LED to a resistor and to ground. This simple circuit was constructed on a breadboard with a built-in voltage source and ground making the process of creating the circuit much easier. After the LED circuit was set up, three optical posts were placed in a line. These three optical posts held in sequential order of placement, the blue LED, the lens, and the glass container holding the fluorescein water-based solution. These posts are spaced apart from each other at distances which allow the light from the blue LED to be focused into the glass container of fluorescein solution. A fourth optical post is placed orthogonally

with respect to the line of three optical posts talked about earlier. In figure 46 the orthogonally placed post is used to hold the fiber patch cable which is then connected to a spectrometer. The spectrometer is then connected to a PC via a USB cable. In our test we used the SpectraWiz application in conjunction with a spectrometer for our wavelength spectrum measurements.

### 7.3.1.9 Preliminary Testing Results

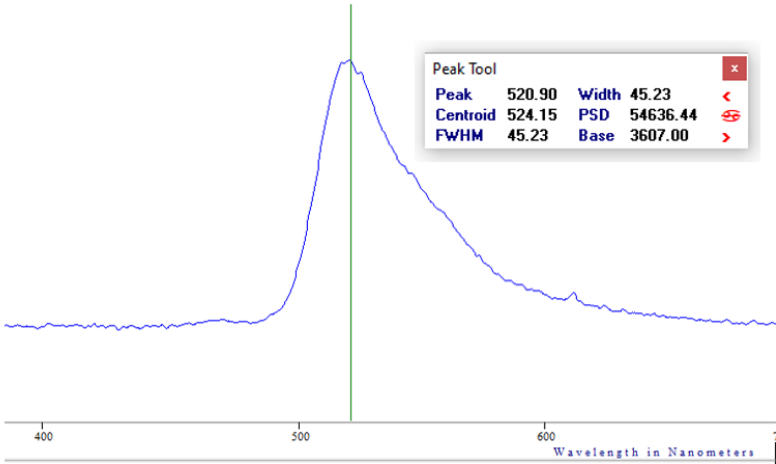

Figure 66 Fluorescein fluorescence emission spectrum measured with spectrometer

Figure 73 above shows the measured fluorescence emission spectrum of fluorescein. Using SpectraWiz we found that the peak fluorescence wavelength of our fluorescein was 520.9 nm which is larger than the 515 nm fluorescence peak wavelength for fluorescein which was given in the specifications of the fluorescein we bought. The FWHM value measured in our test was 45.23 nm. With a FWHM value of 45.23 nm and our observation of the signal falling down to the noise level at a wavelength just below 500 nm, it appears that the fluorescence emission from the fluorescein does not leak into wavelengths close to the intended excitation peak wavelength of 460 nm.

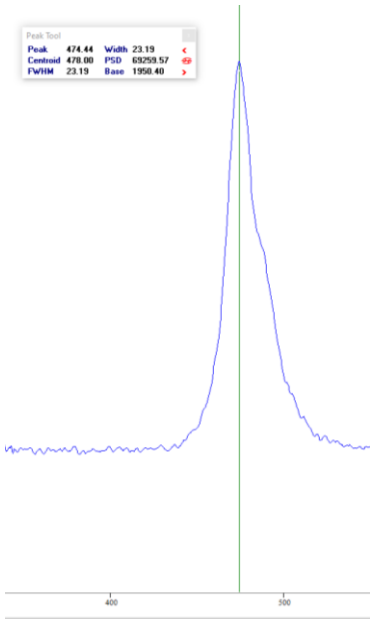

Figure 67 Excitation LED spectrum measured with spectrometer

While we had our system setup for measurement of the wavelength spectrum, we decided to measure the emission spectrum of the blue LED that we used as an excitation source. Similar to that of the peak emission wavelength of the fluorescein, we found that the measured peak intensity emission of the blue LED in fact occurred at a wavelength of 475 nm instead of the peak emission wavelength 465 nm given in the on the box specifications of the LED. The blue LED has a measured FWHM value of 23.19 nm. Based on observation of the blue LED emission spectrum and FWHM value it appears that the spectrum of the LED drops down below the noise level before reaching 515 nm. This drop off shows that the blue LED light emission and fluorescein fluorescence emission can be separated from each other with the use of an optical filter since the LED emission spectrum has negligible or no leakage into the fluorescent emission wavelength spectrum, let alone the peak wavelength of the fluorescein emission.

**7.3.1.10 Senior Design Optical Demo**

The senior design optical demo took place 12/02/2021. The demo was meant to show the subset optical components of your design. Our optical subset demo consisted of many optical components and a circuit board for the LED.

**7.3.1.10.1 Optical Components**

English prism mount
70 mm focal length lens

Everix 500 nm long pass filter
Glass vial used to hold the sample
Outlet powered breadboard
Thor labs 465 nm LED
Optical rotation stages
Optical posts
Integrating sphere
Optical fiber
Lens mount
Spectrometer
LED mount 1k ohm resistor
550 nm bandpass optical filter

*Table 28 Required Optical Components for SD1 Optics Demo*

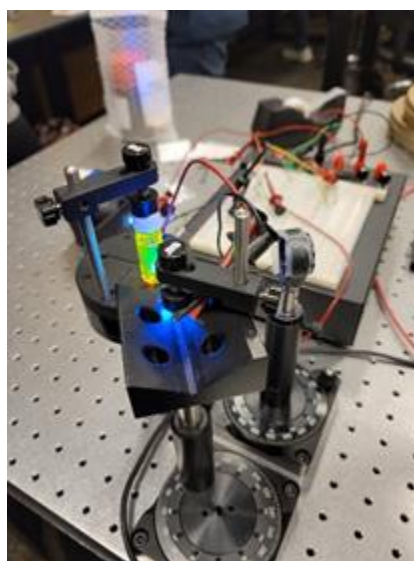

*Figure 68 First part of optical setup demo*

The optical setup used a circuit which consisted of a 1k ohm resistor connected to a 46m nm LED which allowed the LED to run at full brightness using the variable voltage on the breadboard. In line with the circuit was the first optical setup demo which used two rotation stages angled so the light coming from the sample was able to reach the spectrometer.

### 7.3.1.10.2 *Optical Demo Procedure*

Step	Action
1	Use a 1k ohm resistor and a 465 nm LED and connect to a variable voltage breadboard and allow the LED to be put anywhere using wires.
2	Attach the sample directly on the English prism mount and the top clamp to hold it down.
3	Attach post on of the rotation stages and attach the V shaped led mount and use the top clamp to gold it down, then angle the LED towards the sample at the focal length of the lens.
4	Attach another post on the second rotation stage, then attach the lens holder with the lens and angle this lens at a 45-degree angle from the led to capture the most amount of fluorescence.
5	Use a 550 nm bandpass filter and attach it directly to the lens on the side facing away from the sample.
6	Connect the spectrometer to a computer, use the available end of the fiber and put it close the filter in parallel.
7	Turn on the LED at full brightness and observe the spectrum.

*Table 29 Optical Demo Procedure*

### 7.3.1.10.3 *Observations*

From the optical setup, we saw that without the filter attached from the lens, the 465 nm LED leaked from the reflection of the vial into the spectrometer which was shown on the computer. Although the light did leak into the spectrometer there was still a peak difference between the fluorescence and the LED. Adding on the bandpass optical filter, this completely blocked out the blue reflection and would allow for a complete detection of fluorescence only. One of the key features of the optical filter is the OD level. For fluorescence the higher the OD level, the more light you can block out and have a better limit of detection. The OD level of the thick filter we picked was a OD 6 filter which is



needed for fluorescence. This filter will not be used in the final prototype because it cannot be curved which does not allow the design to be more compact.

#### 7.3.1.10.4 Optical Demo Part 2

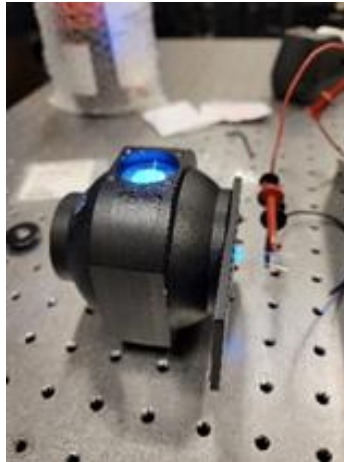

Figure 69 Second part of optical setup demo

The second part of the optical setup demo uses an integrating sphere as the central holder for the sample. An integrating sphere has barium sulfate lined in the interior creating a 99.9% reflectivity on the surface. This will allow the fluorescence to bounce around and allow the most light to exit. Using this method, the blue lights leaks a lot more because of the reflectivity so a filter is also used. The filter used for the integrating sphere is a Everix thin film 500 nm long pass filter. The filter itself has an OD level of about 3.2 causing some of the blue light to leak through but there is still a significant peak difference between the blue light and the fluorescence. Although there is a peak difference, the OD level still needs to be high enough to completely block out the blue light.

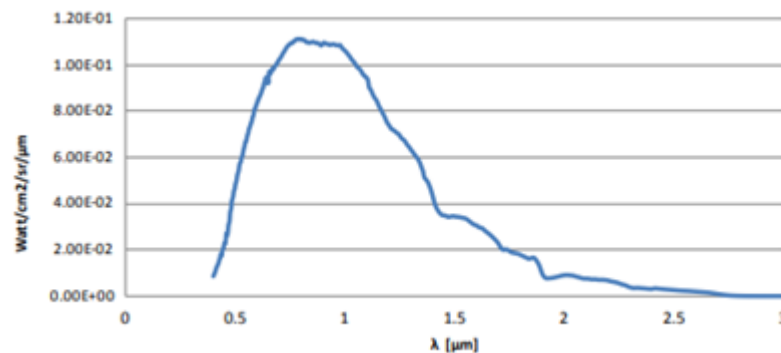

Figure 70 Integrating sphere reflectivity vs wavelength

Integrating sphere specifications:

- Diameter of exit aperture: 1"

- Diameter of sphere: 4"
- Spectral Range: 0.44 – 1.9  $\mu\text{m}$

## **8 Operation Manual**

The device can measure the concentration of fluorescent material, and with proper calibration can be quite accurate at this. The prototype should only be used however as a proof of concept. Much more rigorous testing will be required to make the device a proven medical device.

The contents of this Operation Manual can be used to properly operate, maintain and calibrate the device for basic use, and outlines the functionality of the device.

### **Safety Information**

1. Keep the sampling device in a safe dry place. It is not waterproof, and could short circuit if improperly exposed to the elements.
2. Turn off the device when not in use to save battery power, and electrically isolate the battery so it is not at risk of heating up if stored in un-ideal conditions or the battery malfunctions. Although the circuit has safing mechanisms in place, it is best to take precautions, and not rely on electrical safeties.
3. If the device must be disassembled, take care to keep the optical components clean and free of dust, and handle the device from its edges.

### **8.1 Basic Information**

The device is created for a single use case. To measure the molarity of a particular fluorescent material in solution. That being said, the device has configurability to adjust the excitation light, as well store different sampling profiles. The device will also store sampled readings and show them on a web site served locally by the device.

### **8.2 Basic Use with web GUI**

1. Prepare the sample by filling a sample container ensuring an even distribution of fluorescent material in the sample
2. To turn on the device, flip the power switch to connect the battery, or connect usb cable to 5v power brick and to device. Device will always power up when connected to USB power.
3. Connect to the web page created by the device using any web browser for easy control through web GUI.
4. Verify Sample settings match the type of fluorescent material, and calibration you want to use. Feel free to change selected profile or modify a profile to get the correct settings for the scan.
5. Click Initiate Scan button on web GUI and the device will begin the scan.

6. Once the scan is complete, the reading will be displayed on the web GUI, and previous scans can be accessed using the history page of the web GUI.
7. To start another scan, just hit the initiate scan button again.
8. Various settings of the device can also be configured.
9. To configure the scan profiles, click the menu button, and then open the configuration page. On this page the user can configure profile settings, create profiles, and select default profile.
10. To save a profile, set the settings how you want them, then either click update or create new button to create a new profile or update the current profile. By clicking create new, the device will prompt for a name for the new profile.
11. On the home page, the newly saved profile can now be selected as the profile to use when taking scans.
12. The profile will be saved to the microcontroller memory.
13. To turn off the device, disconnect usb cable, or flip power switch, depending on if the device is running on battery or usb.
14. Store the device in a dry area to avoid potential short circuiting.

### **8.3 Basic Use without Web GUI**

1. Much of the setup remains the same however with no client devices connected to the device's web server, a scan by initiated by pressing the action button on the device once.
2. Upon pressing the action button, a scan will begin.
3. When the scan is complete the value will be stored to the device's internal history, and shown on the display of the device.

### **8.4 Charging**

1. The device has a built in Lithium Ion Charging and protection circuit. What this means is that the device can charge its internal battery using the usb C input on the exterior of the device.
2. To charge the device, first flip the battery switch so that the device is powered on, and connect the usb power cable to a 5v source, and to the device.
3. The device has two indicator leds to let the user know the state of charge of the battery. A red and a green LED.
4. When the device is charging, the red led will be illuminated, and the green LED will be off.
5. When the device has finished charging, the red LED will turn off, and the green LED will be illuminated. If there is no battery, or the charger is not connected, neither light will be on.

### **8.5 Calibration**

Device Calibration is crucial to the accurate operation of the device, and should be done periodically to verify the device is still operating as expected. The full calibration procedure can be found in section 7.1.2 however the user doesn't need to do a full

calibration every time. A simpler operation can be done to verify the device is still producing accurate readings.

1. Prepare a sample with known molarity.
2. Initiate a scan using that sample.
3. Verify that the molarity reading matches the molarity of solution that was prepared
4. If the molarity does not match, recalculate the scaling factor by entering a new scaling factor in the profile used for the scan.
5. Initiate another few scans with the new scaling factor and verify the reading matches the known molarity of the solution. If it does not, recalculate the offset.
6. If the device is still not getting a consistent reading, verify that the LED is lighting up properly.
7. Otherwise check the sample to make sure there is nothing wrong with the container, and not any settling of the fluorescent material.

## 8.6 Troubleshooting

Common issues and their solutions are given in the table below

Problem	Solution
Device will not turn on.	Charge Battery. If the battery is charged and wont turn on, try the usb port for power. If the device works with the usb connected, the issue is likely with the battery, and it will need to be replaced. If the device still does not turn on with the USB connected, the device likely is seriously damaged and should not be used until the PCB can be diagnosed and repaired.
Device is not broadcasting a WiFi network	Verify the device is in AP mode. It may be in Client mode and be connected to an existing wifi network. If it is, then you will have to connect to that network and reconfigure it to broadcast an SSID.
Device cannot be found on my WiFi network	Device may be in AP mode and be broadcasting a wifi network instead of connecting to your network. Look at the screen to see what mode it is in. If it is broadcasting, the WiFi SSID and password will be shown on the display
Device dies quickly after charging fully	Battery is likely near its end of life and will need to be replaced. A standard 18650 cell can be purchased and installed in the device to replace the failing battery. The battery uses

	spring loaded clips and is easily user serviceable.
Readings are not what they are expected to be	A good place to start is to make sure you are using the correct profile, and you have set the scaling factor correctly for the readings. The calibration section is a good resource for this. If the readings are still not as expected after calibration, there could be a device malfunction that is causing the failure.
I can't find the website to access the device	The device IP address can vary depending on the mode that it is in. In AP Mode, the device always has the same IP address. In Client Mode the device will have a DHCP assigned IP address from the router it is connected to. In both cases the IP address is shown on the screen, and the web page can be accessed by typing this IP address into a web browser. If the device fails to serve the web address, then the microcontroller may have faulted, and the device power should be cycled. If this doesn't resolve the issue, the microcontroller may need to have its firmware reinstalled.

Table 30 Troubleshooting Steps

## 9 Administrative Content

### 9.1 Milestone Discussion

Number	Milestone	Planned Completion Week (SD1 & SD2)
1	Initial project document-Divide and Conquer	5
2	Decide on ailment/marker for detection	6
3	Use ailment/marker to choose optical filters	6
4	Use Zemax to test lens designs/choose focal length of lens	7
5	Investigate HMI designs	7
6	Finalize part selection and PCB design	14

7	Order PCB and parts	14
8	Test lenses/photodetector/ADC designs	1 - SD2
9	Create prototype PCB	2 – SD2
10	Order Optical Components	1-SD2
11	Determine the focal length of the plano-convex lens	2 – SD2
12	Determine the wavelength spectrum for the excitation light source and the fluorescence light emission	2 – SD2
13	Determine radiance of the light emitted from the blue LED	2 – SD2
14	Determine the fluorescence light output power of the fluorophore sample	2 – SD2
15	Populate PCB and verify functionality	2 – SD2
16	Ensure that the excitation light output from the LED is properly collimated	3 – SD2
17	Determine the full and half viewing angles of the LED light emission	3 – SD2
18	Determine LED rotation angle, with respect to the to a line through the normal of the sample container, where the optical filter cuts off the most excitation light and the largest fluorescent light peak will is seen	3 – SD2
1219	Design and order updated PCB if necessary	3 – SD2
20	Test software for interfacing microcontroller with different components	3 - SD2
15	Complete Microcontroller software	4-SD2
16	Manufacture enclosure and optical housing	5-SD2
17	Assemble PCB and test circuit works correctly	5-SD2
18	Complete Microcontroller software	5-SD2
19	Repopulate new PCB if necessary, and get working correctly	5-SD2
20	Begin Integration	7-SD2
21	Complete Integration	9-SD2

22	Power Testing including, Power regulator testing, Power switch testing, USB Power testing, and Battery Protection Testing	10 – SD2
23	LED Driver Testing	10 – SD2
24	Photodiode Testing	11 – SD2
25	Wifi Testing	11 – SD2
26	Complete Validation Testing	11-SD2
27	Ensure that excitation light is not leaking through the optical filter used in the fluorescence detection sub system.	11 – SD2
28	Local Software Testing	11 – SD2
29	Web GUI Testing	11 – SD2
30	Determine limit of detection for the optical system within our device	12 – SD2
31	Determine the overall limit of detection of our device including the complete detection system	12 – SD2
32	Deliver Product	13-SD2

Table 31 Milestone Table

## 9.2 Budget and Finance Discussion

Our budget will be funded by our sponsor Everix. The most expensive costs come from the optical filters and lenses. Our sponsor Everix intends to provide their thin optical filters for use in our portable fluorescence sensing device. The lenses have a large cost due to their small dimensions and focal length. Discounting any malfunctions or breakage, the total cost can be calculated from the estimated cost for each component below.

ITEM	QUANTITY	PRICE ESTIMATE
LED	1	\$1-\$20
Cooling for LED	1	\$10-\$50
Photodiode	1	\$10-\$30
Optical filter	1	\$400
Lens	1	\$10-\$100

Custom optical housing	1	\$10-\$100
Custom enclosure	1	\$15-\$20
Display	1	\$7-\$15
Microcontroller	1	\$3-\$30
Power Source	1	\$10-\$50
PCB	1	\$25-\$75
<b>TOTAL (Estimated Range)</b>	<b>N/A</b>	<b>~\$493-\$1,280</b>

Table 32 Cost & Component Budget Table

## 10 Citations

- [1] Y.-H. Shin, J. Z. Barnett, E. Song, M. T. Gutierrez-Wing, K. A. Rusch, and J.-W. Choi, "A portable fluorescent sensor for on-site detection of microalgae," *Microelectronic Engineering*, vol. 144, pp. 6-11, 2015/08/16/ 2015, doi: .
- [2] M. W. Alam, K. A. Wahid, M. Fahmid Islam, W. Bernhard, C. R. Geyer, and F. J. Vizeacoumar, "A Low-Cost and Portable Smart Instrumentation for Detecting Colorectal Cancer Cells," *Applied Sciences*, vol. 9, no. 17, 2019, doi: 10.3390/app9173510.
- [3] R. Paschotta. "Photodetectors." (accessed 10/20/2021, 2021).
- [4] Y.-H. Shin, M. Teresa Gutierrez-Wing, and J.-W. Choi, "Review—Recent Progress in Portable Fluorescence Sensors," *Journal of The Electrochemical Society*, vol. 168, no. 1, p. 017502, 2021/01/08 2021, doi: 10.1149/1945-7111/abd494.
- [5] "475nm CWL, 12.5mm Dia. Hard Coated OD 4.0 50nm Bandpass Filter." Edmund Optics. (accessed 11/3/2021, 2021).
- [6] "Everix Ultra-Thin OD 2 Longpass Filter, 500nm, 12.5mm Square." Edmund Optics. (accessed 11/3/2021, 2021).
- [7] "LED465E - 465 nm Epoxy-Encased LED, 20 mW, TO-1 3/4, Qty. of 5 " Thorlabs. (accessed 11/3/2021, 2021).
- [8] P. C. DeRose, "Recommendations and Guidelines for Standardization of Fluorescence Spectroscopy ", pp. 1-11, October 2007. [Online]. Available:
- [9] "Numerical Aperture." Science Direct. (accessed 10/27/2021, 2021).
- [10] M. J. Kidger. "Marginal and Chief Rays." SPIE. (accessed 10/27/2021, 2021).
- [11] "DSLR camera basics." Nikon. (accessed 2021).
- [12] "Tech Note: Limit of Detection for Fluorescence Spectroscopy." Wasatch Photonics. (accessed 9/20/2021, 2021).



