

Senior Design Final Document

December 4th, 2019

Saving One Life at a Time Using a Water Filtration System That
Includes Solar Panels to Help Underdeveloped Countries.

Solar Powered Water Filtration System



Department of Electrical and Computer Engineering
University of Central Florida
Senior Design 1
Dr. Samuel Richie

Group 24

Cecile Bui: Computer Engineering
Alejandro Gonzalez: Computer Engineering
Gabriel Gonzalez: Computer Engineering
Henok Brhane: Electrical Engineering

Table of Contents

1. Executive Summary.....	1
2. Project Description	2
2.1 Project motivation.....	2
2.2 Goals and Objectives	2
2.3 Requirement Specifications.....	3
2.5 House of Quality Analysis	4
2.6 Hardware Flow Diagram.....	5
3. Research	7
3.1 Existing Projects and Products.....	7
3.2 Relevant Technologies	8
3.2.1 Solar Panels.....	8
3.2.2 Battery.....	13
3.2.3 Microcontroller	29
3.2.4 Remote Connectivity	31
3.2.5 Water Pump	32
3.2.6 Water Filters.....	34
3.2.7 Sensors	38
3.2.8 Voltage regulator.....	48
3.3 Strategic Component and Part selection	54
3.3.1 Solar Panels.....	54
3.3.2 Voltage Regulator	56
3.3.3 Microcontroller	57
3.3.4 Remote Connectivity	58
3.3.5 Water Pump	60
3.3.6 Water Filters.....	62
3.3.7 MicroSD Card Module.....	65
3.3.8 LCD Display	66
3.3.9 Sensors.....	67
4. Standards and Design Constraints	76

4.1 Standards.....	76
4.1.1 Solar Panels Standards	76
4.1.2 Water Filters.....	78
4.1.3 Remote Connectivity	79
4.1.4 International Software Testing Standards	80
4.1.5 Battery standards	81
4.2 Constraints	81
4.2.1 Battery Constraints.....	81
4.2.2 Funding constraint.....	82
4.2.3 Time constraint.....	82
4.2.4 Size constraint.....	82
4.2.5 Components Availability Constraint.....	83
4.2.6 Water Constraint	83
4.2.7 Social Constraint.....	84
4.2.8 Networking Constraint.....	84
4.2.9 Portability Constraint	85
4.2.10 Software Constraint	85
4.2.11 Networking Constraint.....	86
5. Hardware Design.....	86
5.1 Hardware Design Flow Overview	86
5.1.1 Water Pump.....	86
5.1.2 Microcontroller	86
5.1.3 Sensors.....	87
5.1.4 Bluetooth Module	87
5.2 Schematic Design	87
5.2.1 Microcontroller Schematic.....	87
5.2.2 Microcontroller Program.....	89
5.2.3 Bluetooth Module Schematic	89
5.2.4 Water Tank and Case Design	90
5.2.5 Filters Connection Design	92
6. Software Design	93
6.1 Methodologies.....	93
6.2 Tools Used for Development.....	94

6.3 Microcontroller Software.....	96
6.4 Smartphone Application Software	99
7. Testing and Demonstration Plan	101
7.1 Hardware Testing.....	102
7.1.1 Solar Panel	102
7.1.2 Power circuit testing.....	104
7.1.3 Microcontroller testing.....	106
7.1.4 Sensor Testing.....	106
7.1.5 LCD Testing.....	106
7.1.6 Filters Testing.....	108
7.1.7 Bluetooth Module Testing	109
7.1.8 Water Pump Testing	110
7.2 Software Testing	111
7.2.1 Microcontroller Software	111
7.2.4 Smartphone Application Software	112
7.3 Device Setup.....	112
8. Administrative Content.....	113
8.1 Milestone Discussion.....	114
8.2 Budget and Finance Discussion	117
9. Conclusion.....	121
Appendix A- Copyright Permissions	1

Table Of Figures

Figure 1 - House of Quality Analysis.....	5
Figure 2 - Hardware Flow Diagram.....	6
Figure 3 - Homemade water filtration system	8
Figure 4-Small Thin Film Cells, the best choice for our water filtration system ...	11
Figure 5 - ML35-12V MightyMax Battery	19
Figure 6 - Schematic of charging circuit.....	23
Figure 7 -Mohoo PMW solar charge controller	25
Figure 8 - MPPT charge controller – Maximum Power point	26
Figure 9 - PowMr 60a MPPT solar charge controller	27
Figure 10 - SPI Connection Sample	29
Figure 11 - I2C Connection Sample	30
Figure 12 - Power Consumption Profile of LPM.....	31
Figure 13 - Example of System Using Submersible Pump	33
Figure 14 - Standard Transfer Pump	34
Figure 15 - Deaths from unsafe water consumption	35
Figure 16 - Sediment Filter	36
Figure 17 - Pre-carbon Filter System.....	37
Figure 18 - Ultrafiltration Device	37
Figure 19 - Ultraviolet Disinfection Device	38
Figure 20 - pH probe diagram.....	41
Figure 21 - Turbidity sensor mechanism diagram.....	42
Figure 22 - Leak Sensor Mechanism Diagram 1.....	43
Figure 23 - Leak Sensor Mechanism Diagram 2.....	43
Figure 24 - Leak Sensor Mechanism Diagram 3.....	44
Figure 25 - Water flow sensor mechanism diagram.....	45
Figure 26 - Efficiency Vs Load Current.....	50
Figure 27 - Schematic of LM2576 ADJ Voltage Regulator (5V output)	52
Figure 28 - Circuit for the LM2576 ADJ Voltage Regulator	52
Figure 29 - Plot of the Input Voltage and Output Current.....	53

Figure 30 - Plot of the Output Efficiency P_{out}/ P_{in} as a Function of V_{in}	53
Figure 31 - Efficiency of LM2576 ADJ From its Datasheet	53
Figure 32 - Schematic of LM2576 Voltage Regulator (5V output)	57
Figure 33 - Amarine Made 12V Pump	62
Figure 34 - Boeray Ultraviolet Light	64
Figure 35 - SEN0189 Turbidity Sensor	69
Figure 36 - SEN0161 pH sensor probe	71
Figure 37 - YF-B3 Water Flow Sensor.....	73
Figure 38 - DFRobot waterproof temperature sensor probe.....	76
Figure 39 - Pin Mapping	88
Figure 40 - LCD Display Mapping.....	88
Figure 41 - Microcontroller Program Flowchart.....	89
Figure 42 - Bluetooth Module Mapping.....	90
Figure 43 - Filters Order	92
Figure 44 - Microcontroller Software Diagram	98
Figure 45 - Application UI Flow Diagram	100
Figure 46 - Series of UI Tests Part 1	103
Figure 47 - Series of UI Tests Part 2	104
Figure 48 - connection diagram and display modes of charge controller	105

Table of Tables

Table 1 - Advantages and Disadvantages of Monocrystalline and Polycrystalline Panels	10
Table 2 - Comparison of Energy Density	14
Table 3 - Comparison of Different Batteries.....	17
Table 4 - Performance characteristics of the ML35-12 AGM battery	20
Table 5 - PWM/MPPT Comparison.....	27
Table 6 - Specification of The MPPT We Selected	28
Table 7 - Bluetooth and Wi-Fi comparison.....	32
Table 8 - Water pump comparison.....	34
Table 9 - Temperature sensor comparison table	40
Table 10 - Leak Sensor Comparison Table	44
Table 11 - Comparison of Design Software	47
Table 12 - Comparison Candidate Voltage Regulators.....	51
Table 13 - List of Different Types of Solar Panels.....	54
Table 14 - Comparison of LM7805 and LM2576 Voltage Regulators	56
Table 15 - Microcontroller comparison.....	58
Table 16 - Bluetooth modules comparison	59
Table 17 - Transfer Pump Comparison.....	61
Table 18 - Sediment Filter Comparison	62
Table 19 - Pre-carbon Filter Comparison.....	63
Table 20 - Ultrafiltration Filter Comparison	63
Table 21 - Ultraviolet filters comparison.....	64
Table 22 - MicroSD Card Module Comparison	66
Table 23 - Display Model Comparison.....	67
Table 24 - Turbidity sensor comparison table.....	68
Table 25 - pH sensor model comparison	70
Table 26 - Water Flow Sensor Models Comparison Table	72
Table 27 - Water Flow Sensor Comparison Table	73
Table 28 - Temperature Sensor Price comparison	75

Table 29 - Standards for Solar Panels.....	77
Table 30 - Water Filters Standards.....	78
Table 31 - Wireless Connection Standards Table	79
Table 32 - International Software Testing Standards Table.....	80
Table 33 - Battery standards	81
Table 34 - IP Rating.....	91
Table 35 - Senior Design I Milestone Table.....	114
Table 36 - Budget Table for All the Components Needed	117
Table 37 - Task Delegation Table Part 1	119
Table 38 - Task Delegation Table Part 2	120
Table 39 - Task Delegation Table Part 3	121

1. Executive Summary

Every year, about 3.575 million people die from water-related diseases every year. That means somewhere around the world, every ten seconds, somebody dies. Sometimes, we do not see how fortunate we are until we actually get to travel outside the country and see how much we take the little things for granted. Going to a third world country and seeing their living conditions are unfortunately a reality we had to face: they need our help. It is a global catastrophe because it not only affects adults, but it also affects children and newborn babies. Most of the families living in these conditions can barely afford to buy food and having access to safe water is very difficult and sometimes non-existent. That is why we decided to create a water filtration system by using solar panels.

Our water filtration system will make a difference in underserved communities by providing simple yet sustainable water filtration mechanism. By making our water filtration system lightweight and portable, they will be able to have clean and safe water anywhere they go. It will tremendously increase their quality of life and it will also improve their health conditions drastically. They will not have to walk long distances to get purified water. Our project is made for adults and young adults as well. It will save hundreds, thousands or even millions of people.

However, most of the time, these communities lack technical personnel to deal with system failure and routine maintenance, frequent system outages are also a reason people living in these communities go back to drinking unsafe water. By integrating remote sensing procedures to ease this burden and make the maintenance of the system as easy as possible and with the use of a backup battery and/or some hand cranking mechanism to maintain continuity of the system during these times. We hope to solve some of the challenges this people face on a daily basis.

The function of our project is to generate power from solar panels that will go through a filtration system. We will also include a manual pumping system so in case anything was to fail in the system we will still be able to make purified water by using a manual pumping system. The impure water intake will come into the sediment filter system then from there, it will go to the carbon filter where it will reach its final destination, the UV barrel that will sterilize the water. The pure water will then go through the pump and then will expel through the output tubing. We will also include a lithium polymer battery that can take overcharges and it can run for about six hours without the sun on just the pump and about three and a half hours for the UV.

Designing is one of many aspects of the project but also making it safe and easy to use so not only adults can use it but also children can learn how to use it on their own they can use it independently without any assistance. The learning process will go from one household to another and we will be able to save and improve people's quality of life. Building this project is not only exciting, because

we get to build something from scratch but most importantly, we get to make a difference in people's lives.

2. Project Description

With our water filtration systems, we will be able to provide to underdeveloped countries a safe and healthy way to drink water. Not only will they have a portable filtration system at their house, but it will also save millions of lives from the multiple diseases associated with drinking unsafe water.

The following section will include:

- Our motivation that leads to the creation of this project.
- The impact we want to make in somebody's life.
- The requirements and specifications we need to comply to in order to build a successful portable device.
- The house of quality analysis of the project.

2.1 Project motivation

According to the World Health Organization, "more than three million people die from water-related diseases every year". That means somewhere around the world, every ten seconds, a human being dies. The water death related diseases include the following: polio, cholera, typhoid, and the one that is causing more than five hundred deaths, diarrhea. Sometimes, we do not see how fortunate we are until we actually get to travel outside the country and see how much we take the little things in life for granted. Going to a third world country and seeing their living conditions are unfortunately a reality we had to face: they need our help. It is a global catastrophe because it not only affects adults, but it also affects children and newborn babies. Most of the families living in these conditions can barely afford to buy food and having access to safe water is very difficult and sometimes non-existent. Unfortunately, contaminated water also affects most areas, from rural to urban, big or small cities, where people with very low income cannot have access to clean and healthy water.

2.2 Goals and Objectives

Our main goal is to make a difference in somebody's life by providing simple yet sustainable and portable water filtration device. However, most of the time, these communities lack technical skills to deal with system failure and routine maintenance or frequent system outages. For that reason, we integrated few sensors and we also included an LCD display that will be easy for the user to read and will contain the following information: an LCD display that will show the pH, turbidity, temperature and will also let the user know when it is time to change one

of the filters. We made the device as lightweight as possible and also, we made the maintenance of the system as easy as possible, with the use of a backup battery and a manual pumping systems in case one day the entire filtration system stop working. We hope to solve some of the challenges this people face on a daily basis by designing a water filtration system using solar panels in order for everyone to have access to safe and healthy water no matter where they are and most importantly, water that is not contaminated. The function of our project is to generate power from solar panels that will go through a filtration system that will generate safe and clean water.

2.3 Requirement Specifications

In this section of our water filtration system, we enumerated all the requirement specifications needed for our project: we listed all the dimensions for the case, the solar panels, and the microcontroller. We also included the weight for the case, and the solar panels. The voltage for the water pump and the Bluetooth was also mentioned. The water content and how much it generates were listed as well as the power for the solar panels and then UV lamp.

1. The case for the entire apparatus should be less than 10 pounds.
2. Solar panels (3) should be 13.2 X7.3X 1.5 inches and should be less than 1.5 pounds.
3. Solar panels have as output 21W.
4. The microcontroller dimensions should be less than 2.7 in x 2.1 in
5. Water temperature should be measured to a precision of at least ± 5 degrees Fahrenheit.
6. Water tank should hold at least half a gallon of water.
7. Water pump should generate 4L/min.
8. Water pump should use less than 12V to save on battery power
9. UV lamp is used to sterilize the water and consume less than 12 W.
10. Bluetooth operating voltage should be less than 6V

2.4 Features

In this section of our project, we included the main features that make our water filtration system stand out compare to other water filtration system projects. It includes the following characteristics such as being lightweight, portable with detachable magnets for our solar panels. The entire device is compact and includes an application that is easy to use for adults, as well as for young adults.

1. Solar panels should be removable.
2. Solar panels should be waterproof.
3. LCD should display pH, turbidity, temperature and when the filter needs to be changed.
4. UV lamp is used to sterilize the water.
5. Turbidity sensor should test the quality of the water.
6. All the components should fit in the main case.
7. Device should be easy to use, for adults just as for young adults.
8. Device should have a smartphone app that will be incorporated in the device.
9. Smartphone app should have an UI that is ready to read for the user.
10. Smartphone app should run on Android.
11. Device should be able to be used with solar panels which will generate power, or the device can also be used manually.
12. Wi-Fi Module should have low power consumption.
13. Wi-Fi Module should communicate via UART.

2.5 House of Quality Analysis

The creation of a Quality Function Deployment (QFD) or House of Quality helps us direct our attention to the many factors that matter the most to our clients/users when designing a product. Once we understand our user's needs, we can design a series of matrices, charts and efforts that went through to translate those to every phase of our project development.



Figure 1 - House of Quality Analysis

2.6 Hardware Flow Diagram

Figure 2 represents an approximation of how each component on our design will be connected and interacts with each other. Our system uses solar panels as an energy source. These solar panels charge a battery to which the rest of the devices that require a direct power source are connected.

One of the devices connected to the battery is the water pump. This is one machine that consumes the most energy in our system. The water pump then pushes water through a pipe connected to water flow sensor. The water pump sensor then lets the water flow through the first filter, a sediment filter. This filter is connected to Pre-Carbon filter that is connected to a UF filtration membrane. These last three parts of the system don't require any power source to function since they work using the water pushed from the water pump. The UF filtration membrane is connected to UV-Chamber. In contrast to the filters the UV-Chamber requires power from the battery. This is the component that requires the most energy in our system. The UV-Chamber is the last of the water purification devices in our system and is connected to a second water flow sensor. This sensor is the last device in the water path of our system and lets the filtered water flow to the second water tank.

Another component connected directly to the battery is the microcontroller unit. The microcontroller then manages and powers each of the sensors employed in

the system. The two water flow sensors previously mentioned are also connected to the microcontroller. Temperature, pH and turbidity sensors go from the microcontroller to the filtered water tank, to monitor the water condition. A leak sensor located in the case is also powered and managed by the MCU. The last three devices connected to the microcontroller unit are: an LCD display to show sensor data and alerts, a microSD card module to store the data, and a Bluetooth transmitter to communicate to the application.

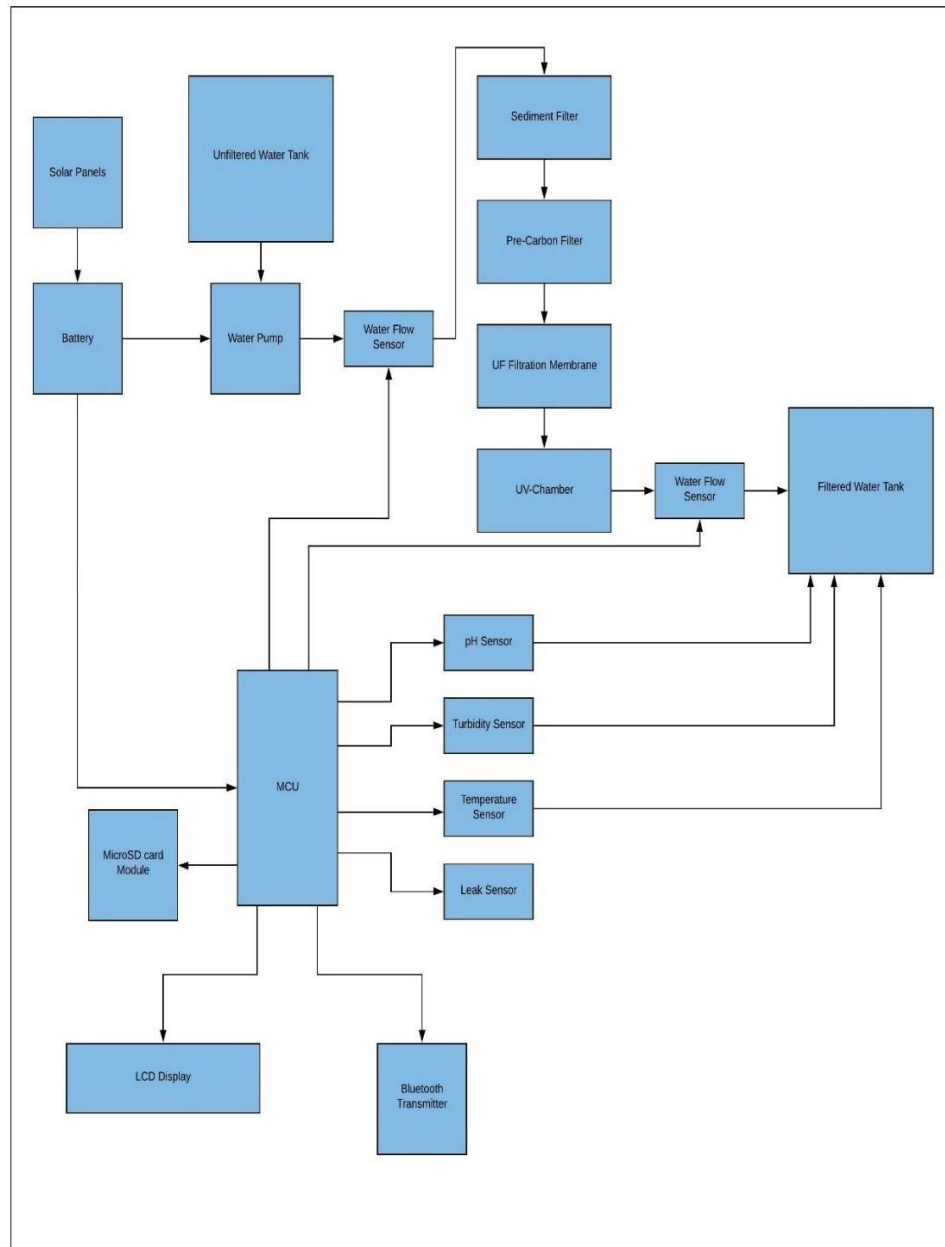

Figure 2 - Hardware Flow Diagram

3. Research

In Africa for example, before solar panels came into place, the only way to get clean and safe water was for many people to walk every single day about an average of 2 kilometers, which is the equivalent of 1.24 miles to get drinkable water. Today, solar panels have made a tremendous impact on people's lives. Solar panels have become a tremendous source of electricity and it does provide significant environmental, ecological and socioeconomics benefits.

The following section will include:

- Ways of making your own water filtration system as well as products sold on the market.
- The important technologies and research that are involved in the making of this project.
- The different options given to build the project and which components best suited our project.
- Reasons behind why we chose specific parts of the project over others (comparison research).

3.1 Existing Projects and Products

There are different filtration systems products on the market that provide safe and healthy water. It can either be portable or it can be physically installed at the user's house. It is just a matter of preference and what is more convenient: the solar panels can be installed on the roof and have the water filtration system installed inside the household or have the entire apparatus in one case and being able to carry it around. Our main objective was to make it lightweight, easy to use, and being able to carry it wherever we want to go.

On the other hand, there are many other resources that teach on how to make their own water filtration systems. They show how easy it is to make and it only requires components and materials that they can easily find at any home supply store. Figure 3 shows a homemade water filtration system that simply consists of a portable charger, a small filter and a water bottle. This is just one example of the many different types of portable filtering devices that can be made.



Figure 3 - Homemade water filtration system [1]

*Permission Granted

3.2 Relevant Technologies

The following section will include all the relevant technologies we used based on our own research of each and every component our project. We will show the importance of all the parts that we will be using in our project and how they are related to each other to make this project works and be successful. All the relevant technologies learned will help us sharpened our skills and better our project.

3.2.1 Solar Panels

Solar energy is used in so many different ways: they can be seen almost everywhere, from residential properties to commercial properties and schools. Solar panels have changed the lives of so many people as it has become a major source of electricity and it does provide significant environmental, ecological and socioeconomics benefits. Solar panels can be used in small scale, for example we can use a very small solar panel to charge a small device such as a mini portable fan as it will produce enough energy for the device to work properly. Solar panels can also be used in large scale that will need a tremendous amount of power such as power plants.

Since solar panels play an important role in our water filtration system, we had to do our own research on the different types of solar panels available on the market and we had to make sure we are using the one that is appropriate to our project. Different solar panels mean different materials and multiple uses. One important factor in our decision was to pick a solar panel that will combine and save enough heat and then from the generated amount of heat, convert it into power, electricity.

As for source of power, we also included in our project a backup battery that will be used in case the entire system shuts down or if the weather conditions do not provide enough sunlight for the device to work properly.

Different Types of Solar Cells

Today, there are different solar panels available on the market: monocrystalline, polycrystalline and the new flexible, thin film panels. They all differ in shape, size, materials, and quality. In this section, we will talk about the different types of solar panels, their advantages and disadvantages and which one will be the best fit for our water filtration system.

We will be talking about the differences between monocrystalline and polycrystalline in terms of durability, looks, the efficiency, and the size as well as the cost per watt.

The first difference is how the cells are made: Monocrystalline cells are made from a single ingot of silicon that is cut into wafers. Polycrystalline cells are made from multiple pieces that are melted into one wafer. Polycrystalline cells are made with a newer process that is less expensive. Once the cells are formed into solar panels, they both will have distinctive shape. The monocrystalline cells are cut off at the corners while the polycrystalline cells are not. The monocrystalline solar panels are black or a very dark blue color whereas polycrystalline solar panels are bluish. Monocrystalline also do slightly better in lower light conditions so they may produce more power for a little bit longer compare to the polycrystalline panels.

When it comes to durability, these panels are extremely durable. They have an aluminum frame with a tempered glass top to cover all of the solar cells that produce the energy. Manufacturers generally cover these panels for about 25 years which is a long time when it comes to product warranties which is definitely good for our project. When it comes to the weather conditions, these panels are extremely resistant to all types of weather including high winds, severe cold and extreme heat, as well as high winds and even medium sized hail. As far as efficiency and size of each of these panels, monocrystalline panels are made with a higher grade of silicone, so generally they are slightly more efficient than the polycrystalline panels. When it comes to efficiency, as far as the percentage of energy that is converted into electricity, monocrystalline is on the high end with about 20% and when it comes to polycrystalline panel, it is about 17% or so. Because monocrystalline are slightly more efficient, however, it does not mean that they perform better. What it means is that they can produce more power for the same space. In order words, that simply means that their footprint is just slightly smaller than a polycrystalline panel so if we have for example a 150 watt monocrystalline compared to a 150 watt polycrystalline panel, the monocrystalline panel is just going to be slightly smaller in dimensions and will not take up quite as much space as the polycrystalline panel. If one of the main issues is limited space,

it is more preferable to go with the more efficient pen: the monocrystalline.

As far as the cost per watt for each of the panels, monocrystalline and polycrystalline, in general, they are around the same but because since monocrystalline panels are produced with a higher grade of silicone compared to the polycrystalline panels, that in turn means the manufacturing process will be slightly more expensive which then makes the consumer a little bit more for those products. Few years ago, the monocrystalline panel was around \$8 per watt but as time as gone on and as demand for solar panels has tremendously increased, those costs have gone down. Today, it is very easy to find both a monocrystalline and polycrystalline at high efficiency panel for about eighty-two to ninety cents per watt. The following table contains the summary between monocrystalline and polycrystalline panels, as far as the advantages and disadvantages of each that we have just discussed.

Solar Cell Type	Advantages	Disadvantages
Monocrystalline Panels	<ol style="list-style-type: none"> 1. Extremely durable 2. 25-year warranty 3. About 19-20% efficient 4. Smaller footprint 5. More heat tolerant 6. Slightly better in low light 	<ol style="list-style-type: none"> 1. More expensive
Polycrystalline Panels	<ol style="list-style-type: none"> 1. Extremely durable 2. 25 years warranty 3. Less expensive than monocrystalline 4. Easier to make than monocrystalline. 5. Lower heat tolerance than monocrystalline 	<ol style="list-style-type: none"> 1. About 14-16% efficient 2. Lower space efficiency 3. Aesthetically less appealing than monocrystalline.
Flexible Panels (Thin-Film Cells)	<ol style="list-style-type: none"> 1. Flexible 2. Lightweight 3. More appealing than standard panels 4. Mass production is easier 5. Convenient if the space or weight is an issue. 6. Shading has less effect on solar panel performance compare to monocrystalline and polycrystalline 	<ol style="list-style-type: none"> 1. Short manufacturer warranty 2. Expensive 3. Degrade faster than monocrystalline and polycrystalline

Table 1 - Advantages and Disadvantages of Monocrystalline and Polycrystalline Panels

As far as flexible panels, for efficiency and the size, these flexible panels are not as efficient as the old-school panels. On a high-end or the average for these flexible panels is about 13% efficiency compare to the traditional panels that have about 16% to 17 % of the polycrystalline and the almost 20% of the monocrystalline. For the difference in efficiency, more panels will need to be bought or each panel is going to be larger size, it will also have a larger footprint, larger surface area to produce the same amount of energy. When it comes the to the size of the types of panels, traditional and flexible panels, the traditional panels are significantly bulkier and heavier than the flexible panels which is one of the major advantages that the flexible panels have over the traditional ones and when it comes to it, for example in 150 watt panels on an RV are about 25 pounds for the traditional panels and are about three to four inches thick compare to a thin film flexible panel for 150 watt on an RV would be around eight pounds and about an half an inch thick. That is a tremendous and significant difference.



Figure 4 - Small Thin Film Cells, the best choice for our water filtration system [2]

*Permission Granted

For the cost difference between the traditional panels and the flexible panel, the traditional panels will be around eight to ninety cents per watt for a decent quality panel and the cost for a flexible panel is about one dollar and thirty cents per watt which is a significantly a little more expensive than the traditional panels.

Since our water filtration systems mainly relies on portability and is a huge factor, the flexible panels would be a better suit for our senior design project.

Wiring for Solar Panels: Series vs Parallel

Watts is the product of volts and amps. As an example, if we have three panels at 150 Watts for a total of 450 Watts solar array so we know that we have 150-Watt panels at 17.5 Volts and that gives us around 8.6 Amps of current on each of those panels.

If we choose to wire them in series, the panels will be attached to a string, meaning that each of the three 150 Watts panels will be combined into a singular 450 Watts panel. In terms of the solar array, the positive line on one panel will be wired to the next negative line on another and then that second negative line will be wired to the third positive line. We will then get a “singular” 450 Watts panel that has a single negative wire coming out of it and a single positive wire coming out of it. However, the voltage of the system will change when the wiring is in series, so when we wire 150 Watts, 17.5 Volts panels together, 17.5 Volts will be multiplied by 3 which will give 52.5 Volts. So now that we have 450 Watts panel that is 52.5 Volts, we will get 8.6 Amps. The only element that will change will be the voltage.

If we choose to wire the solar panels in parallel, it is actually the opposite of wiring them in series. Each of the 150 Watts panels is going to remain separate panels. They are going to be individual panels producing individual amounts of energy at 17.5 Volts. The only element that will change when wiring them in parallel where a positive and negative line come out comes out of one and a positive and negative line comes out of the next one and so on, none of them are connected together so what will change in this case is the amps of the solar array. So, if we have a 450 Watts solar array at 17.5 Volts, then we will get 25.7 Amps which is 8.6 Amps for each panel multiplied by 3 since we are using 3 panels which gives us 25.7 Amps.

To determine which type of wiring configuration, series or parallel, is best for our water filtration system, there are major advantages and disadvantages that have to do with the following: wire sizing, shading issues and the charge controller size. As far as wire sizing, wire size is strictly correlated with the number of amps running through that specific wire so each wire is rated for a specific amount of amps or current flowing through it. In other words, the smaller the number of amps, the smaller the size of wires. So, in our example, the 450 Watts panels wired in series was at 70 Volts and at 8.6 Amps and in the 450 Watts panels wired in parallel was at 70 Volts and at 25.7 Amps. The panels wired in series will have smaller wires coming off those panels compare to the panels wired in parallel.

When it comes to shading that is where the advantages and disadvantages change. The parallel wiring is a major advantage compare to the series wiring. It is mainly due because in series wiring, they are all combined together so it is a singular unit where all the panels work together to produce that energy. When one of those solar panels is shaded, the entire unit goes down and this has to do with the fact that this is mainly how solar panels work. If we have a single 150 Watts solar panel and that solar panel is shaded, it will stop producing energy. The only reason the entire system goes down is because they are all wired together so each panel depends on the other one. It becomes an advantage when it comes to wiring them in parallel is because all those panels are individual panels so if one panel gets shaded we will only be 33.3 % down since we have 2 more panels that we can rely on and still convert solar energy to electricity.

Last, to determine which type of wiring configuration, series or parallel, the charge controller size also play an important role to determine the best type of wiring configuration. The amperage coming from the solar panels wire in series and the amperage coming from the solar panels wire in parallel is a major difference. There are much more amps coming from the solar panels wired in parallel versus the solar panel wired in series. The higher the numbers of amps are, the higher the requirements for the charge controller are going to be. In other words, a solar array wired in parallel will need a much bigger charge controller than a solar array wired in series.

By looking at the wire sizing, shading issues and the charge controller size, the best type of wiring that would suit our water filtration systems would be to wire them in series. The lower the number of amps is, the lower the requirements for the charge controller will be. Since our device is portable is lightweight, we need less current than if it was wired in parallel. As far as the shading, our filtration system is portable, and the solar panels can be easily removed so it is convenient to move the apparatus where there are no obstacles between the sun and the water filtration system.

3.2.2 Battery

Our solar Panels do not connect directly to our devices. The solar panels will be connected to a rechargeable battery. So, battery is the next step to store the energy that is harvested through photovoltaic cells from our solar panels. Since the power harvested from the solar panels is delivered in DC. We just need to distribute it based on our devices power requirements with the help of voltage boosters and regulators discussed earlier. Today there are a lot of varieties of batteries in the market. For our project to make the comparison first we defined the expectations of our system from the batteries first.

We considered portability, techniques used to charge the batteries since they use different technologies, reasonable price and size, although most of them are around the same price for our solar panel. In addition to the above factors we also checked the following capabilities.

- **Battery capacity:** This means the size of the battery. It is measured in milli Ampere/Hour (mAh). This simply shows the rate it charges a device. For example, if a cellular device is rated at 3000mAh. And they used a fully charged battery rated at 4,500mAh. It means the cellular device can be completely charged one and half times.
- **Current output:** this shows the rate at which a device is charged. In case of the cellular device example above, the device can get charged faster if the battery has higher amperage output. But it will deplete the battery faster.

We also came across few terms used to characterize and compare batteries. These characteristics often are used in comparing solar charging batteries.

- Gravimetric power density - indicates the loading capability or the measure of how much energy a battery contains in comparison to its weight. Batteries for power tools are made for high specific power and come with reduced specific energy (capacity).
- End of Discharge voltage (EODV) - The measured cell voltage at the end of its operating life is called the EODV, which stands for End of Discharge Voltage (some manufacturers refer to this as EOL or End of Life voltage).
- Constant-voltage charger - a circuit that recharges a battery by sourcing only enough current to force the battery voltage to a fixed value.
- Constant-current charger - a circuit that charges a battery by sourcing a fixed current into the battery, regardless of battery voltage.

The physical properties of a battery greatly determine the durability and efficiency of how much energy is to be provided to the product, since the material it's made up of in turn determines the temperature tolerance, and resistance and its overall capabilities.

Energy Density

Another important feature to consider when selecting a battery is its energy density. For example, from the few ones we compared Li-ion batteries can provide energy for a longer time than Ni-Cd and Ni-MH based on the similar physical size. Also, they have advantage in their ability to be designed much lighter than the other Ni-Cd or Ni-MH. It can also be inferred that Li-Ion can run twice as long with the same battery weight as the other two. This feature of Li-Ion greatly intrigued us as we are trying to make our water filtration system light and portable. Also, its small size compared to the other batteries is additional advantage as it does not take much space and can fit easily.

Here in the table is a summary of the comparisons mentioned above.

Battery- type	Li-Ion	Ni-Cd	Ni-MH
Volumetric Density (W-Hr/L)	210	140	180
Gravimetric Density (W-Hr/Kg)	90	50	55

Table 2 - Comparison of Energy Density

Discharge stability.

When a battery is discharged, it is reversing the charging process and is using its potential electric energy to drive the electrical components like the microcontroller and the sensors. This is called battery discharging, as the opposite to battery charging. The discharging current depends on power consumption of these electronic devices. And this is a very important characteristics of batteries as it impacts the overall stability of the system. For instance, a single Li-ion cell has a nominal voltage of 3.6V, and it is three times that of a single Ni-Cd and Ni-MH battery and, its charge capacity is more powerful since fewer cells are required for providing more voltage. But as we can see in the figure below it has steeper curve compared to the flatter curve of Ni-based batteries, and although flatter curve means less voltage variation and better discharge, the other advantages of Li-Ion battery outweigh this advantage of Ni- based batteries.

Next, we compared some batteries based on the above-mentioned characteristics, price and other unique features they possess. Currently these are the most popular types of rechargeable batteries used in the world for solar and portable battery powered devices. Ni-Cd, Ni-MH, Lead acid and Lithium-ion.

Lead-Acid Batteries

Lead-Acid batteries have been around for over century. It is mainly used for renewable energy and off-grid applications. They are inexpensive compared to newer technologies. In 1999 lead–acid battery sales accounted for 40–45% of the value from batteries sold worldwide (excluding China and Russia), equivalent to a manufacturing market value of about \$15 billion. Large-format lead–acid designs are widely used for storage in backup power supplies in cell phone towers, high-availability settings like hospitals, and stand-alone power systems. A small-scale Lead – acid battery for our project with output of about 12.6V is constructed in multiple small cells, each producing about 2.1 volts which usually are connected in series. Each cell consists of a negative and positive lead plate separated by an insulator and an electrolyte which is usually made up of sulfuric acid and water.

An advantage of Lead-Acid batteries is, they are built with a very durable material. They are perfect in areas where there are physical vibrations and they can tolerate strong impact. They are less expensive compared to other batteries. They need to be maintained well and they take longer to charge. Portability, light weight, and fast charging is the focus of our water filtration system. These batteries need to be disposed very carefully as they can cause severe injuries. Due to their durability and tolerance for impact they are very popular in the automotive industry.

Lithium-Ion Polymer.

Lithium-Ion Polymers is a rechargeable battery of lithium-ion technology using a polymer electrolyte instead of a liquid electrolyte. High conductivity semi-solid

(gel) polymers form this electrolyte. These batteries provide higher specific energy than other lithium battery types and are used in applications where weight is a critical feature, like mobile devices. They are commonly used to power modern electronic devices. The main difference between Li-Ion and Li-Po is the chemical structure where Li-Po uses a polymer electrolyte (gel), and Li-Ion uses common liquid electrolyte. Both batteries are very similar and therefore, except Li-Po batteries have a higher specific energy. But this perk comes with the disadvantage that it costs more and that is why Li-Ion is still the better option for our project compared to Li-Po rechargeable batteries.

Lithium ion Battery

Lithium-ion battery is a type of rechargeable battery commonly used for portable electronics and electric vehicles. They are now growing in military and aerospace applications. Like most batteries, the lithium ion battery has two terminals called the Anode (+ charge) and the cathode (- charge). The cathode is made from a metal oxide like cobalt oxide and the Anode is made from carbon. And in between the electrodes, there are electrolytes in the battery. The electrolyte carries positively charged lithium ions from the anode to the cathode and vice versa through the separator.

The movement of the lithium ions creates free electrons in the anode which creates a charge at the positive current collector. Once the cathode is full of these ions, electrons are attracted due to cathode becoming more positively charged than the anode. Then we can let our devices use the energy from the battery, because we force the electrons to move to the device first and then to the cathode, as shown in the figure below.

Because lithium is one of the lightest metals, it has the largest electrochemical potential, and it also provides the largest energy density for its weight. Most of today's cellular devices run on single celled lithium outputting roughly 3.6 volts.

One of the main reasons why the lithium-ion batteries are popular is because they are rechargeable batteries with slow self-discharge rate and they're used in our daily devices like our smart phones, laptop chargers etc. According to the U.S. Solar Energy Monitor 70% of the energy storage technology is lithium ion.

The lithium ion produces a lot more electrical power/unit of weight compared to the other batteries, so lithium ion batteries store the same amount of charge as other batteries but in a smaller size, which was the one of the main reasons we were very interested in these batteries, its portability.

For our project we researched for a portable, light weight battery that matches the solar panels output and one that satisfies our components needs. Since our project is designed for less fortunate or for people who don't have access to clean water.

It is important for the whole apparatus to be light weight so people can carry it to different places in their search drinking water.

Lithium - polymer battery although it has similar operation to Li - ion battery and can provide better performance, it is way higher price. And for a cheaper price, the Lithium-ion battery can perform the job without significant output difference with Lithium – polymer battery.

In the following figure we can see a summary of the pros and cons of the discussed batteries.

Battery type	Pros	Cons
Lithium polymer	<ul style="list-style-type: none"> *Rechargeable *Ultra-thin design * Very Light weight * Safe * Can be manufactured in different sizes 	<ul style="list-style-type: none"> * Requires special protection * Short life cycle *More expensive
Lithium ion	<ul style="list-style-type: none"> *Rechargeable *Slower self-discharge *Provides higher current *Higher energy density 	<ul style="list-style-type: none"> * More cost * Shorter life span
Nickel Cadmium	<ul style="list-style-type: none"> *Rechargeable *Charge faster *Operate in wide temp. range 	<ul style="list-style-type: none"> *Low energy density *Faster discharge rate *Made from toxic material
Alkaline	<ul style="list-style-type: none"> *Rechargeable *Very slow discharge rate *Can operate at low temp. *Eco-friendly raw materials 	<ul style="list-style-type: none"> *Bigger in size *Heavier *If leaked can damage material
Lead Acid	<ul style="list-style-type: none"> *Rechargeable *Can withstand fast, slow and overcharging. *lead can be recycled and re-used in new batteries again. 	<ul style="list-style-type: none"> *Very durable and safe *long life cycle *low chance of leakage *cheaper price

Table 3 - Comparison of Different Batteries

From comparing these batteries, we felt the lead - acid battery fits our demands more and we picked it for our project because the alkaline battery although they have good features, like they can operate at a very low temperature, they are safe for the environment and their charge can last up to 7 years without being used.

The disadvantage to our project is they are bigger in size and heavier so it defeats the purpose of our project, we're trying to make it light and portable plus it can damage the material if accidentally leaked, which is a safety concern.

We decided not to pick the Nickel cadmium because it is made from toxic material, and since this water filtration system is going to be around people most of the time it is not safe also it has faster discharge rate, it can deplete the battery in a faster rate. these batteries generate a noticeable amount of heat and take a longer time when charging.

The Lithium ion is a popular battery, although it is a little more expensive than the other batteries and it has shorter life span, its slow self- discharge and higher current and energy density makes it preferable than the other most of the other batteries we considered in addition the lead acid battery.

Li-ion batteries have about 90% efficiency compared to Lead-acid batteries which have about 80% efficiency, and for our project we narrowed our battery search between these two batteries.

After carefully considering the nature of our project we decided to implement it using Lead-acid batteries. we had three reasons for picking Lead-acid batteries, since our project is meant to be for less privileged people who mostly live in rural areas and who don't have enough means to maintain the advanced Li-ion batteries, we wanted to avoid the hassle and maintenance concerns. Lead-acid batteries are very durable and very tolerable to most impacts.

The second reason we settled with Lead-acid batteries is because they are cheaper compared to Li-ion batteries. although Lead-acid batteries can be heavier than Li-ion batteries, compared with its financial aspect, we believe cheaper price is more beneficial for our target users of this product. In addition, Lead acid batteries are easily accessible and can be recycled to like new features with easy techniques. Even in worst case scenarios a car battery can be used to do the job. We believed this adds convenience to the system.

Third reason is although not as important as the first two, our project is funded by us and we found it more economical to pick Lead-acid batteries without compromising the overall efficiency and output of the system. also lead batteries have a high energy density and an efficient charge to discharge ratio. This means that they can withstand deep discharges and still maintain efficiency and longevity. The battery we decided to use is the MIGHTYMAX ML35-12V 35AH U1 Deep Cycle AGM Solar battery.



Figure 5 - ML35-12V MightyMax Battery [3]

*Permission Requested

This battery comes with pretty good interesting features. Some of the interesting advantages of this battery include:

- It is a spill proof battery, and has a characteristic of high discharge rate, wide operating temperatures, long service life and deep discharge recover.
- Rechargeable battery that can be mounted in any position, resists shocks and vibration. Long lasting high performance in high and low temperatures.
- Its dimension is (7.68 x 5.16 x 7.13) inches. So, it is not physically that big and heavy which is a crucial factor in our project as we are trying to make it as small and light as possible.
- like most batteries it is backed by a 30-day refund policy and full 1-year warranty.

Performance characteristics

The performance and capability of the battery is summarized in the following table.

Capacity 77°F(25°C)	20 hour rate (1.85A、 10.8V)	37Ah
	10 hour rate (3.5A、 10.8V)	35Ah
	5 hour rate (5.7A、 10.5V)	28.5Ah
	1 hour rate (20A、 9.6V)	20Ah
Internal Resistance	Full charged Battery77°F(25°C):10mΩ	
Capacity affected by Temperature (10 hour rate)	104° F(40°C)	102%
	77° F(25°C)	100%
	32° F(10°C)	85%
	5° F(-15°C)	65%
Self-Discharge 68°F(20°C)	Capacity after 3 month storage	90%
	Capacity after 6 month storage	80%
	Capacity after 12month storage	60%
Max. discharge current77°F(25°C): 330A(5S)		
Charge (Constant Voltage)	Float: 13.6~13.8 V/77° F/(25°C)	
	Cycle:14.4~14.7 V/77°F/(25°C) Max. Current: 10.5A	

Table 4 - Performance characteristics of the ML35-12 AGM battery

Charging techniques

Another thing we learned while researching this is, Li-ion batteries are not as durable as nickel metal hydride or nickel cadmium designs. They may explode if overheated or if charged to an excessively high voltage. Also, they may be irreversibly damaged if discharged below a certain voltage, and to avoid this, lithium-ion batteries generally contain a small circuit that shuts down the battery when it is discharged below about 3 V or charged above about 4.2 V, so it is very important to implement the appropriate charging techniques.

In addition to the earlier mentioned benefits of Lead-acid batteries, this exposure to explosion is one of the reasons we decided not to go with Lithium-ion batteries. Since our target users for this application are underserved communities or people in developing countries, we didn't want to adhere them to these safety concerns. On the contrary Lead acid batteries are very durable and overcharging concerns for these batteries can be avoided with simple circuits and controllers that are explained in the following charging and charge controlling circuits.

Charge Controllers

The main job of a controller is simply to block the reverse current and prevent overloading of the batteries. A controller is an essential part of any system that charges batteries. Its purpose is to keep batteries properly powered and charged safely. In addition, some controllers protect against electrical overload, prevent over discharge and show the status of the battery. In most controllers, the load current passes through a transistor that acts as a valve to control the current. Also, in some controllers, a relay is used as a switch. Next, the relay cuts at night and prevents the occurrence of reverse currents.

Another application of the controller is the overload prevention that is when a battery reaches full charge and cannot store any more of the incoming energy. Moreover, the battery voltage will be too high if power continues to apply. Then, this can lead to unnecessary chemical process: that is the water will be separated from the hydrogen and bubbles are formed rapidly.

Next, if excess water is lost, the gases may ignite and cause a small explosion. The battery will degrade quickly and may overheat. Similarly, when the opposite scenario occurs that is, when the voltage drops due to low sunlight or an increase of electricity, the controller allows as much charge as possible. This is the most essential function of load controllers.

The regulators are set at voltage and regulate the charge of the battery in response. Moreover, the controllers regulate the flow of energy to the battery by switching the current completely. In addition, controllers reduce the current gradually and use pulse width modulation (PWM) technology. A pulse width modulation (PWM) controller keeps the voltage more constant.

The regulator operates with two stages: the first keeps the voltage at a safe level, so the battery charges to its full capacity. Then, the voltage will then drop, and a final charge is sustained. Two-stage regulators are important for a system that may experience many days or weeks of excess voltages at which the controller charges the load rate are called set points. When the ideal set point is determined, there compromise between charging quickly before the sun goes down, and the battery overcharging slightly. In addition, determining the set points depends on the anticipated use model and the type of battery. Some controllers have adjustable set points while other controllers do not.

Series Charge Controller

A series charge controller uses a regulation device in series with the input to control the charging of the battery. This typically utilizes a relay to open and close the circuit between the battery and the input. The series controller takes advantage of using open circuits as opposed to short circuits as seen with shunt controllers. However, the purpose remains the same; once the battery voltage reaches a set

voltage point, the controller disconnects from the battery to prevent overcharging, and when it falls below that, it reconnects the battery and allows it to charge.

Lead Acid Battery Charger circuit

In addition to our charge controller circuit we will add this charger circuit in order to ensure the safe charging of our battery and to show the status of the power, charging and discharging of our battery. This simple circuit is used to charge our MIGHTYMAX ML35-12V 35AH U1 Deep Cycle AGM rechargeable solar battery.

This solar charger has current and voltage regulation. It also can cut-off charging when the battery is fully charged. This circuit may also be used to charge any battery at constant voltage because output voltage is adjustable using a potentiometer, which is a variable resistor.

Solar battery chargers operate on the principle that the charge control circuit will produce the constant voltage. The charging current first passes to our LM317 voltage regulator through the diode D1. The output voltage and current are regulated by adjusting the adjust pin of LM317 voltage regulator. Battery is charged using the same current.

Circuit Components

- Solar panel
- LM317 voltage regulator
- DC battery
- Diode – 3 1N4007 and 1 1N4732A
- Capacitor – 0.1uF
- Diodes – 1N4007, x 3, 1N4732A (Zener)
- Resistors – 1Ω (5W), 1KΩ x 2, 1.2KΩ, 1.5KΩ x 2, 10KΩ
- 50 KΩ potentiometer
- 5MM LED = red, green, blue, yellow
- 2 alligator clips and a jumper
- 12 V relay.

Before use this circuit needs to be calibrated first. Initially, we set the jumper between positions 2 and 3 for calibrating. Then we slowly turn the 50KΩ Potentiometer until the “Charged” LED turns ON. Once the LED turns ON, we disconnect the power supply and connect the jumper between 1 and 2. Now our circuit is ready to receive voltage from our panel.

For charging our 12V Battery:

We set the output voltage to 14.5 volts. (This voltage is specified on the battery as cycle use). This 14.5V we set in the calibration to compensate for the drop voltage is called Tripping Point. When the Tripping point is set to 14.5V, the battery will charge for about 75% of its capacity.

If we want to charge to a higher percentage, we can increase the tripping voltage. Although it is not recommended if we want to charge the battery at 100%, we can set the tripping voltage to about 16 volts, which pretty much is the voltage provided by our panels, and hence no need to use the regulator. But this scenario can damage the battery life and whole circuitry and is not recommended.

Now we can calculate the charging current by:

$$\text{Charging current (I)} = \text{Solar panel wattage/Solar Panel Voltage} = 5 / 17 = 0.29A$$

This way we can determine the size of the panels to adjust to the charging current required by the battery. Or we can change the regulator that has the desired amperage.

To calculate time taken for charging:

$$\text{Time (hrs.)} = \text{rated current amperage of the battery} / 0.29A.$$

For our project it will take about four and half hours.

We can also calculate the power dissipated by the equation $P=V*I$.

$$\text{Power(w)} = 14.5V * 0.29A = 4W$$

Our solar panel is rated at 5W, this means the 1W is going to the regulator. And all these calculations / parameters are done before charging the battery, to avoid overcharging and for proper charging.

This solar battery charger circuit advantages include:

- Adjustable output voltage

- The circuit is simple and inexpensive, as we are funding our project so far, we can construct this circuit with commonly available components without affecting the overall quality of the system.
- There is no battery discharge when there is no sunlight on the panels.
- This circuit can be used for other batteries with slight modification.

PWM Charge Controller

The Pulse Width Modulation (PWM) charge controllers send short charging bursts or pulses to the battery instead of a steady flow of current. This happens when the battery is full and the end of each pulse the charge controller briefly switches off to measure the battery capacity and adjust its output values to match. This allows batteries to be fully charged without stressing the battery.

PWM controllers aim to extend and optimize battery life instead of focusing on efficient power transfer. PWM controllers also tend to be much more inexpensive than MPPT charge controllers.



Figure 7 -Mohoo PMW solar charge controller [4]

*Permission Requested

MPPT charge controller

The MPPT charge controller ensures that the loads receive maximum current to be used (by quickly charging the battery). The maximum power point tracker MPPT is an electronic DC to DC converter that improves the solar PV panels, and the battery bank. Maximum power point could be understood as an ideal voltage at which the maximum power is delivered to the loads, with minimum losses. This is also commonly referred to as peak power voltage.

Maximum Power Point Tracking (MPPT) features a connection between the photovoltaic panel and the battery bank. The indirect connection includes a DC/DC voltage converter that takes additional photovoltaic voltage and converts it into additional current at a lower voltage without losing power.

The maximum point (MPP) describes the point on the current voltage (I-V) curve at which the solar PV device generates the largest output. That is where the product of the current intensity and the voltage is at its maximum.

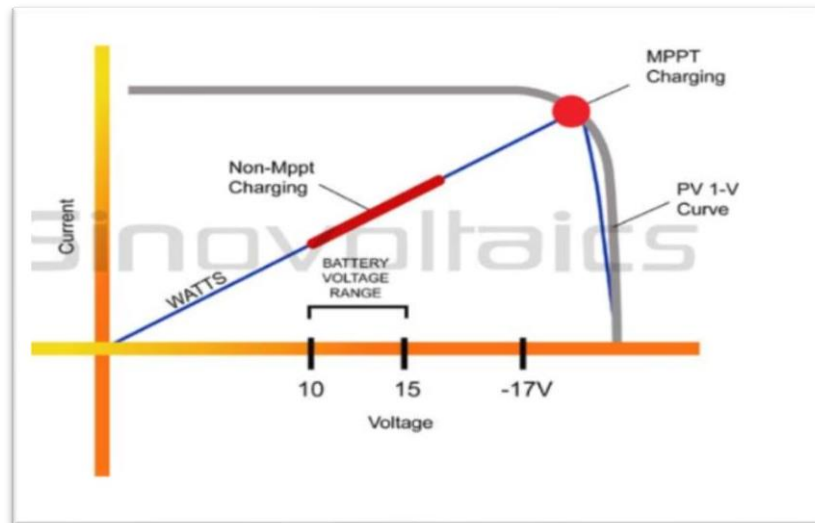

Figure 8 - MPPT charge controller – Maximum Power point [5]

*Permission Requested

The advantage of MPPT controllers: The controllers offer a potential for improved load efficiency up to 25% - 30%. Also, the controllers offer greater sensitivity to system growth and the option of placing panels in series at higher voltages to the bank of batteries for up to 85A. Furthermore, the warranties for the maximum power point tracker MPPT load controllers are typically higher than the pulse width modulation PWM. MPPTs are more expensive than PWM but yield more options and power.



Figure 9 - PowMr 60a MPPT solar charge controller [6]

*Permission Requested

PMW or MPPT

For our project we first summarized what each controller’s advantages and disadvantage are. The following table it summarizes

	PMW charge controller	MPPT charge controller
Advantages	<ul style="list-style-type: none"> * Reasonable price *safer *long life cycle 	<ul style="list-style-type: none"> * Easier implementation. *less regulators required
Disadvantages	<ul style="list-style-type: none"> * The solar input must match battery bank. *pulse width can’t have strings. 	<ul style="list-style-type: none"> * More expensive * A fuse breaker is required for protection * less safe during installation. Higher DC voltages can cause shock.

Table 5 - PMW/MPPT Comparison

Specifications							
Product Model	Z10	Z20	Z30	CM-40A	CM-50A	CM-60A	
Batt Voltage	12V/24V auto						
Recognize range	9V~15V for 12V system 18V~30V for 24V system						
Max Charge Current	10A	20A	30A	40A	50A	60A	
Max Discharge Current	10A	20A	30A	20A	30A	30A	
Max Input Power (Don't exceed)	12V	120W	240W	360W	520W	650W	780W
	24V	240W	480W	720W	1040W	1300W	1560W
Max Solar Input	Max 23V for 12V battery Max 46V for 24V battery			Max 24V for 12V battery Max 48V for 24V battery			
Equalization	14.4V						
Float Charge	13.7V (default,adjustable)						
Stop Charge Voltage	10.7V (default,adjustable) The voltage controller stop output to protect battery						
Over Discharge Recover Voltag	12.6V (default,adjustable)						
Voltage of Open Ligh	Solar panel 8V (Light Lights delay)						
USB Output	Dual USB output,5V / 2.5V (MAX)						
Terminal Size	#12 AWG			#4 AWG			
Battery Type	b01		b02		b03		
	AGM=Sealed		GEL		Flooded		
Self-Consume	<10mA						
Operating Temperature	-31°F~+140°F						
Size / Weight	5.86 * 2.87 * 1.30 IN / 0.44lb						

Table 6 - Specification of The MPPT We Selected

3.2.3 Microcontroller

The single board microcontroller to be used for this project needs to meet certain requirements that are crucial for the correct operation of the water filtration system. Various sensors will be used to analyze, and store data related to the water quality and the status of the different filters. The microcontroller must be capable of receiving multiple inputs from the sensors without any type of problem. A low power consumption microcontroller is also a necessity for any device that is operated with the use of solar power. Low power consumption will allow the filtration system to be operable for longer periods of time allowing constant analysis of the whole system. Another essential requirement for the microcontrollers is the ability to transmit the information gathered to an external device, for this reason the microcontroller needs to be compatible with wireless modules that allow sharing data via Wi-Fi or Bluetooth.

Microcontroller Communication Protocols

One of the most popular interfaces to connect sensors is SPI (Serial Peripheral Interface). SPI allows the microcontroller to communicate with multiple peripheral devices over short distances. The microcontroller acts as a master device and controls the transmission between the slave devices that are the sensors used in this project. Three lines are used to communicate all devices and one line specific for every device. SPI is the simplest and fastest protocol when compared with other communication protocols.

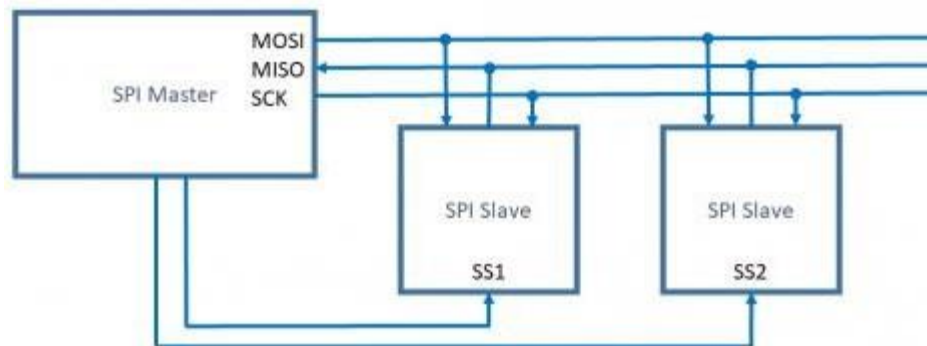

Figure 10 - SPI Connection Sample [7]

*Permission Requested

Another popular communication protocol is I2C (Inter-integrated circuit). This protocol is very similar to SPI but brings with it certain advantages and disadvantages when compared with the other protocols. I2C, like SPI, is used mainly to connect a microcontroller with different sensors or peripherals. I2C is a simple protocol that only uses 2 bidirectional wires to communicate with other devices,

the transmission of data is more reliable than SPI because of this, and it can have multiple masters. The disadvantage that comes with I2C is that it is a more complicated protocol and it is not as fast as SPI because of its reliability.

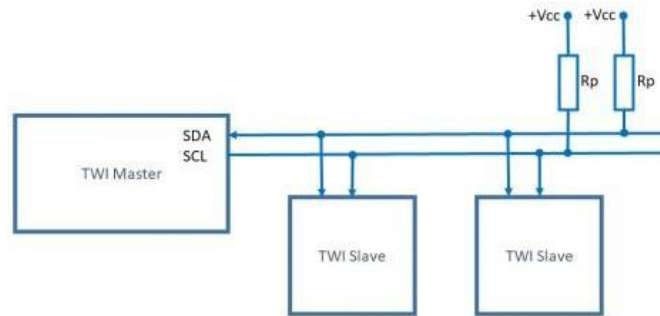

Figure 11 - I2C Connection Sample [7]

*Permission Requested

Lastly the other important protocol to be considered for this project is UART (Universal Asynchronous Receiver/Transmitter). This protocol is a simple serial communication protocol that allows the host to communicate with the auxiliary device and support asynchronous, bidirectional or serial transmission with different devices. The interface between the microcontroller and Bluetooth module is usually done with this protocol and will allow the device to communicate with the mobile application as it is intended for this project. The disadvantages of this protocol are its low speed and the capability of having only one master device, but it is simple to operate and also allows communication between the microcontroller and complex devices.

Low Power Mode

Low power modes are available in most microcontrollers and they allow the use of it for longer periods of time. Taking advantage of these modes and choosing a microcontroller that allows a significant reduction of the power consumption is crucial when working with system power up by solar energy.

Microcontrollers like Arduino Uno or MSP430 provide different mechanisms that allow reduction of the power consumption. These modes consist mainly of disabling functions on the chip. For the MSP430 five different low power modes are available. The first one disables the CPU, the following one the loop control for the fast clock (MCLK) is also disabled, followed by the fast clock (MCLK), the DCO oscillator and its DC generator, and lastly the crystal oscillator is also disabled.

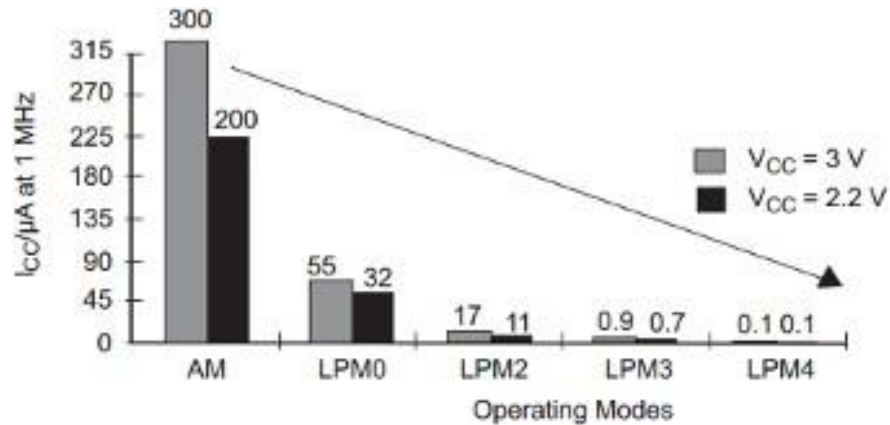

Figure 12 - Power Consumption Profile of LPM [8]

*Permission Requested

The image above shows the different amounts of power consumptions between each of the modes. It can be seen in the image that the difference between the use of low power modes change drastically the power consumption of the microcontroller.

Arduino Uno also provide similar mechanism like low-power software libraries, and its own built-in sleep functionality designed to help with power saving. This mechanism provides similar results to the ones seen on the MSP430 and can be useful for the operation of the water filtration system and its multiple sensors.

3.2.4 Remote Connectivity

One of the main features of this project is the mobile app that will be developed to analyze, and interpret the data obtained from the different sensors. In order to communicate the filtration system with our smartphone it is needed a wireless communication method. The two most used wireless technologies for exchanging between fixed and mobile devices are Bluetooth and Wi-Fi. To choose one of these technologies several points have to be considered.

Wi-Fi

Wi-Fi is nowadays the most used wireless technology because of its frequency range that goes 2.4 GHz and 5 GHz, its range which can go up to 100 meters, and its high bandwidth. However, Wi-Fi brings several disadvantages when we consider the purpose of our project. While it is true that Wi-Fi is most commonly used for mobile apps the problem it brings is that it requires a local area network, via the use of a router or a mobile hotspot and its high-power consumption. Both of those disadvantages bring important consequences to our water filtration system since its main purpose is for it to work areas with little to no access to either power or internet connection.

Bluetooth

The other wireless technology to consider is Bluetooth. While this one may not have the range that Wi-Fi provides, Bluetooth does not require a local area network and its power consumption is significantly lower. Bluetooth provides a frequency range of 2.4 GHz, a range of maximum 10 meters, and a power consumption of 100 mW. The disadvantages it brings are its limited support of simultaneous users, and less security when compared to Wi-Fi. However, when we consider our project main goal, which is to help people at developing nations to obtain clean water, Bluetooth is definitely our best option. Lack of power or internet connection can be mostly ignored when using Bluetooth, and it is a reliable way of sharing data widely use around the globe.

Connection	Power Consumption	Range	Interference	Bandwidth
Bluetooth	100 mW	10 meters	Minimum of 2.4 GHz	1 Mb/s
Wi-Fi	750 mW	100 meters	2.4 GHz -5 GHz	54 Mb/s

Table 7 - Bluetooth and Wi-Fi comparison

3.2.5 Water Pump

A water pump is one of the oldest and most used machines and can be found in a variety of mechanisms. A water pump is a crucial part of our water filtration system and many factors have to be considered for us to correctly choose the best water pump for our project. Size, power consumption, cost, weight, and flow rate are the main factors that our group had to consider. Transfer and submersible pumps are the two types of water pumps that are the most commonly used for filtration system.

Submersible Pump

As the name suggest submersible pumps are design to be immerse in the water source in order to extract the water. The advantage of this type of pump is that they are very efficient, conserve a lot of energy, can handle solids or liquids, and are very quiet. However, submersible pumps are also more expensive than transfer pumps, and it is more difficult to notice any type of failure quickly since they are submerged under water. For this reasons we will not use this type of pump

for our project, since constant monitoring of the water pump via the mobile app is an essential part of our device, pressure sensors will be used to control the status inlet and outlet of the water pump and this cannot be done if the pump is submerged under water. Another problem of this type of pump is that it will conflict with the portability of our device making it harder to design a comfortable way to transport it.

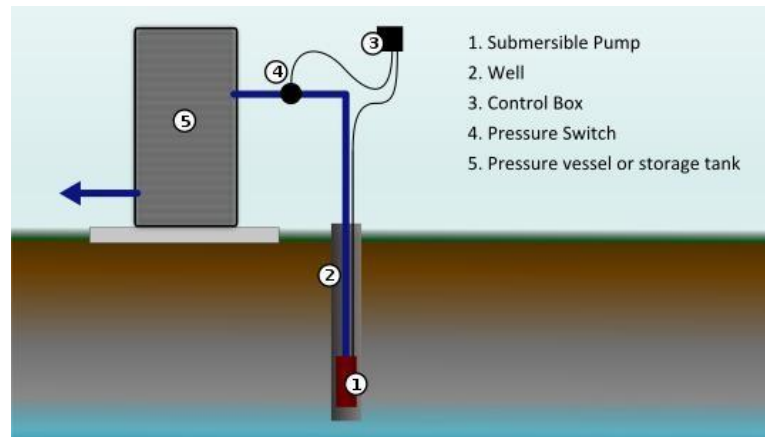

Figure 13 - Example of System Using Submersible Pump [9]

*Permission Requested

The image above shows an example of a system that uses a submersible water pump to extract water. It can be clearly seen that for a system to use a submersible pump it has to be stationary.

Transfer Pump

Transfer water pumps are usually used to move large quantities of water from one place to another. They are easy to manage, mostly used for rural application and have a low price when compared to other types of pump. This type of pump is very portable, easy to monitor and can be used to extract water or other liquids from different water sources.

For our device the group decided to use this type of pump since it is the best option to make the device as portable as possible, and the different transfer pumps available meet the cost, size, power consumption and weight constraints previously mentioned.

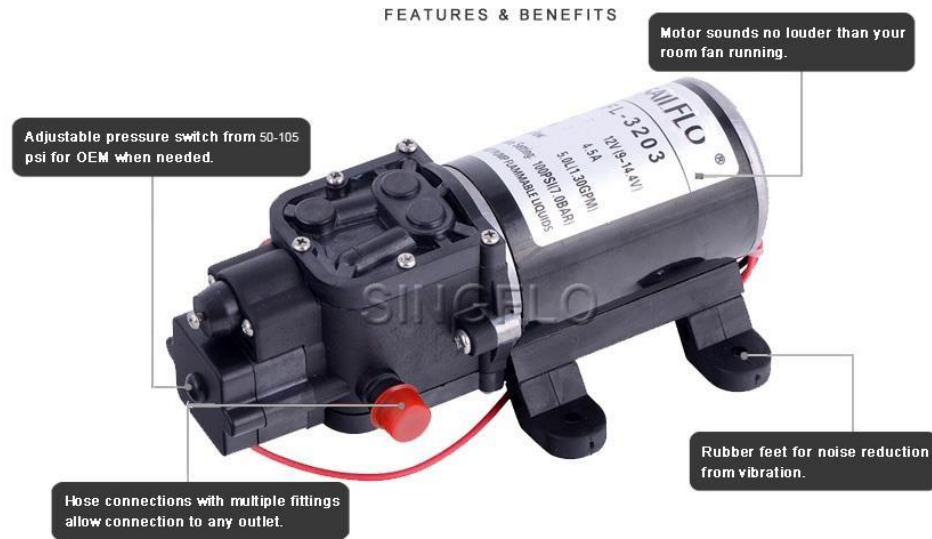

Figure 14 - Standard Transfer Pump [10]

*Permission Requested

Transfer Pump	Submersible Pump
Easy to maintain	Heavy maintenance
Easier to manipulate	Not portable/ Harder to manipulate
More efficient	Less efficient
Larger use of energy	Conserve energy
Louder	Inaudible

Table 8 - Water pump comparison

3.2.6 Water Filters

Lack of access to safe water is a problem that still affects many people around the world. According to the World Health Organization “Over 1 billion people globally lack access to safe drinking-water supplies, while 2.6 billion lack adequate sanitation; diseases related to unsafe water, sanitation and hygiene result in an estimated 1.7 million deaths every year.” This is why one of our main priorities is

to provide the user with good quality water that meets all the required health standards. Figure 15 shows the amount of deaths per million caused by the consumption of unsafe water worldwide.

Deaths from unsafe water, sanitation and hygiene

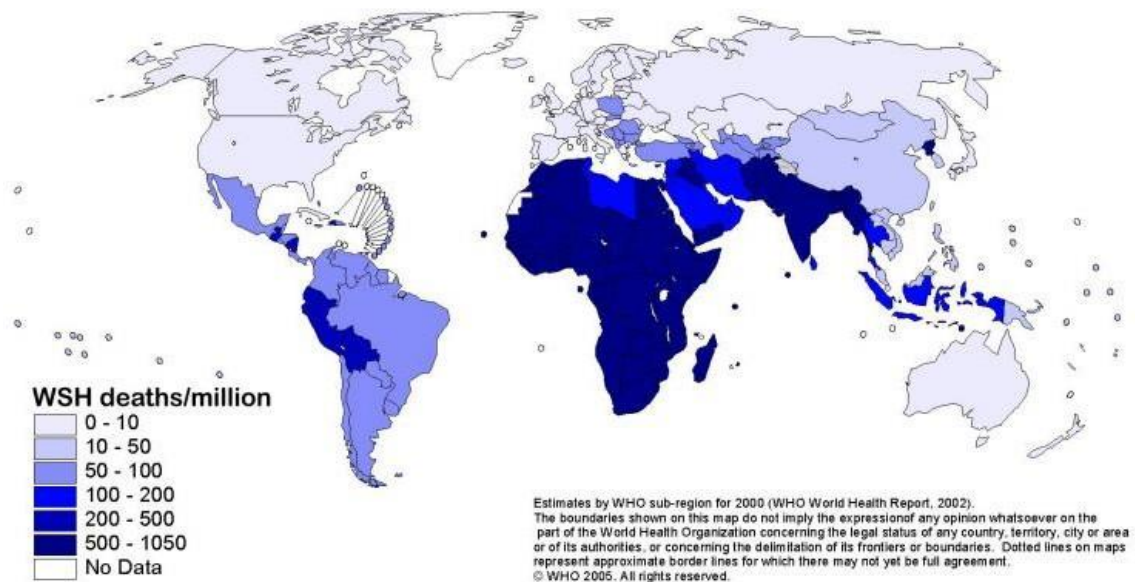

Figure 15 - Deaths from unsafe water consumption [11]

*Permission Requested

The most important bacterial diseases transmitted through water are cholera, gastroenteritis, typhoid fever, bacillary dysentery, acute diarrheas. All of these are dangerous diseases that affect more commonly the population of developing countries. For this reason, the filters that we will use for this project have to target specifically the microorganisms and bacteria that causes these diseases.

The water filters to be used for our device are probably the most important part of this project, if low quality filters are used it would affect both the outcome of the device and potentially the health of the users. For this reason, our group decided to use four different types of filters to ensure the safety of those who use the product and to get the best possible product.

The four types of filters to be used in our project are a sediment filter, a pre-carbon filter, an ultrafiltration membrane (UF), and an ultraviolet water purifier. These four filters will ensure that the filtered water is drinkable and safe for the user.

Sediment Filter

The purpose of this filter is to remove any suspended solid like mud, dirt, and debris from water. A sediment filter is always the first layer of a filtration system since it gets rid of any sediment that the water might contain so that ultraviolet filters or ultrafiltration membranes can operate efficiently.

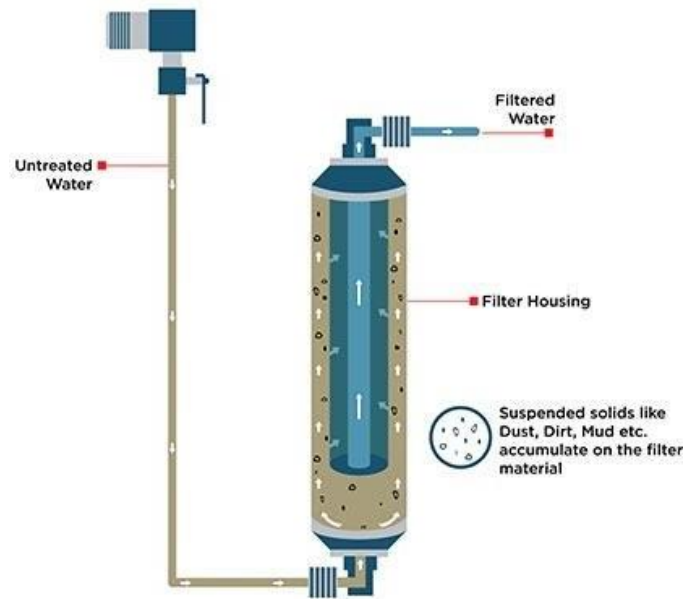

Figure 16 - Sediment Filter [12]

*Permission Requested

Pre-carbon Filter

This filter absorbs and eliminates chlorine, organic chemicals inside the water, and odor active matters. It also focuses on the removal of toxic components like lead, copper, chloroform, chemical residuals, herbicides, pesticides and other volatile organic compounds.

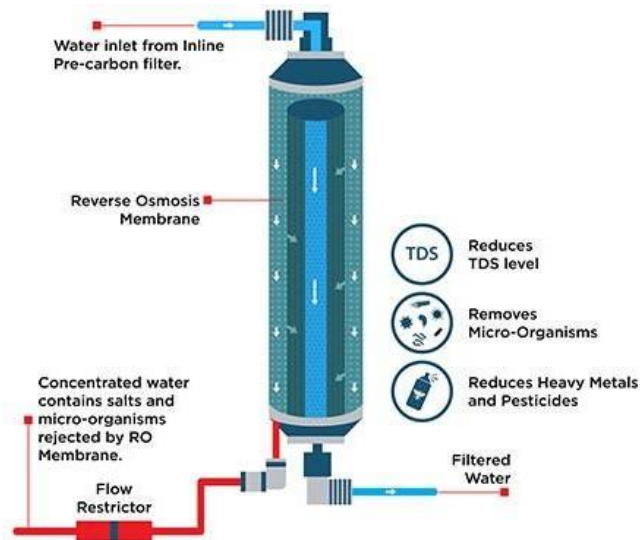

Figure 17 - Pre-carbon Filter System [12]

*Permission Requested

Ultrafiltration membrane

Ultrafiltration membrane are used to remove particulates articulates and macromolecules from raw water, to produce potable water. This technology removes cysts, spores, fungi, algae and bacteria. This type of filtration devices is commonly used as a secondary part of a filtration system where any types of solid have been already removed from the water. This device ensures great quality water by removing more than 90% of pathogens found in contaminated water sources. Other benefits of Ultrafiltration devices are their compact size and that no chemicals are required for the process.

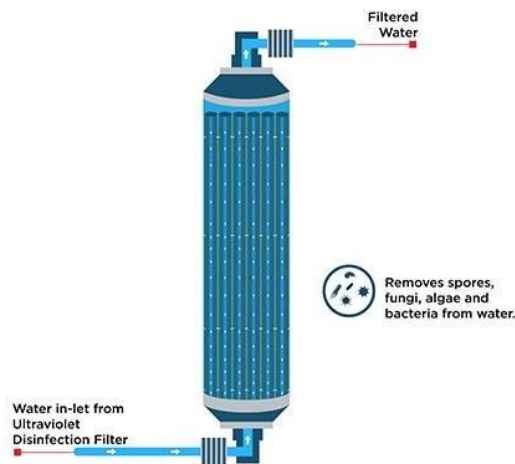

Figure 18 - Ultrafiltration Device [12]

*Permission Requested

Ultraviolet Water Purifier

Ultraviolet water filters are probably the most effective way of removing disease causing bacteria and viruses from any type of water resource. This type of device has been proven to remove and destroy 99.99% of harmful microorganisms without adding chemicals or changing your water's taste or odor. Among the many advantages of using ultraviolet filters the most important ones are chemical free system, little energy usage, low maintenance, and taste and odor free.

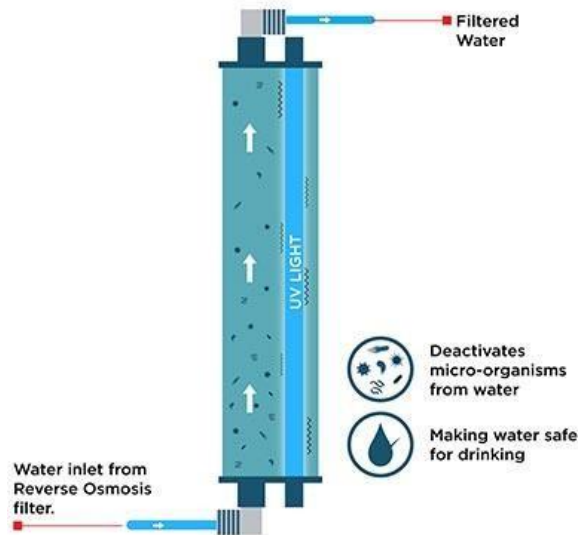

Figure 19 - Ultraviolet Disinfection Device [12]

*Permission Requested

3.2.7 Sensors

In our project we use multiple sensors that track the pH, turbidity, temperature, and depth of the water, as well as leak and pressure sensor for the system. The readings from the pH and turbidity sensors help determine the quality of the filtered water and if it is safe for consumption. The temperature and depth readings from the sensors verify that the product is operating within its operating limits and sends alerts to the display and app when it is not. The pressure and leak sensor determine the conditions of the filters and detect any problem in the systems.

All the readings and measurements from the sensors are sent to the app where they are used to ascertain the current condition of the filters as well as calculate the approximate amount of time the filters can continue to operate before they need to be replaced. This is calculated based on the amount of time the filters have been in use, the pressure and temperature of the water going through the system as it operated, and the resulting turbidity and pH of the water after filtering.

There are multiple aspects to be taken into consideration in order to make a decision as to which sensors to use in this project. Size is an important aspect to take into account for the parts used in the system, since one of the objectives of the project is to make it a small and portable as possible for easy use. Although most of the sensors can be found in small sizes, some particular model offers more accurate readings but are bigger in size. Using those sensors would then require making the system bigger and would increase its weight, which negatively affects its portability.

Another important aspect to take into account when choosing the sensors is long term durability. This system is intended for use in developing nations, and thus is required to operate under the assumption that it will have little maintenance over long periods of time. Some of the available sensors maintain better accuracy in the long term making their replacement unnecessary for a longer time.

The system in this project is powered by a battery that is charge with solar panel making low power consumption a key aspect in the design. There are multiple sensors that offer low overall energy consumption and include a low power mode that help maximize the battery life on the whole system.

Considering that the intended use for the filtration system is in developing countries with little access to drinking water, an important factor in this system is cost. Among the available options of sensors offered higher levels of precision and accuracy on their reading, as well as greater measuring ranges. When choosing the sensors for this project it becomes necessary to consider how much precision is needed and how wide the range of the readings needs to be. This allows the selection of cheaper sensors that have the minimum requirements necessary for the system and to avoid buying ones that are more expensive and operate outside those requirements.

Temperature Sensor

In our project it is particularly important to keep track of the water temperature. Both the filters and some of the sensors used in this system need to operate in a certain temperature range. Going above or below certain temperatures may negatively affect the useful lifespan of some of the components in our filtering system. For this reason, in our design for the filtering system we decided to include a water temperature sensor that could monitor the filtered water. If the water ever goes above or below the safe operating temperature of any of the systems component the microcontroller unit would send an alert to the app and display to inform the user of the problem.

There are various kinds of temperature sensors. However, for this project we considered two particular types of temperature probes that work on water. The first type of temperature sensor that we researched for our project was a sensor based on semiconductors. This sensor works by using integrated circuits to measure the

temperature. They rely on the change of voltage across a p-n junction in response to temperature change. Semiconductor temperature sensor offer excellent high sensitivity, linearity and small sizes.

The other type of temperature sensor that was considered for our project is an NTC thermistor. This stands for negative temperature coefficient. In this type of sensor, the resistances rises and falls continuously. These changes in resistance are caused by temperature, thus allowing it to calculate the temperature based on these changes. The resistance of the sensor decreases when the temperature increases, and the resistance increases when the temperature decreases.

Sensor Type	Advantages	Drawbacks
Semiconductor	<ol style="list-style-type: none"> 1. Operating range of -55°C to 125°C 2. Low Cost 3. High sensitivity 4. Linear 5. Small size 	<ol style="list-style-type: none"> 1. Slow response. 2. Lower precision.
NTC	<ol style="list-style-type: none"> 1. Accurate. 2. Fast. 3. Large operating range: -55°C to 250°C 	<ol style="list-style-type: none"> 1. Requires calibration.

Table 9 - Temperature sensor comparison table

The semiconductor type sensors have an operating range in between -55°C and 125°C. This is smaller than other types of sensor, but still in the range in which our system will operate. These sensors are cost efficient and provide other advantage such as linear response and high sensitivity.

The NTC sensors on the other hand are very accurate and detect changes in temperature fast. They also provide a greater operational range of -55°C to 250°C.

Taking the previous factors into consideration we decided to utilize a semiconductor type temperature sensor. Despite their slower response time and precision, this sensor still meets the requirements to full the necessities of our project, while providing an easier to interpret linear response.

pH Sensor

The design for our project includes a sensor that monitors the pH of the filtered water. Measuring the pH of the water after being filtered is extremely important since this is one of the decisive factors on whether the water is safe for

consumption. According to the Environmental Protection Agency (EPA) consuming water that is extremely acidic or alkaline is harmful. In order to be within EPA standards water for human consumption must have a pH value in the range of 6.5 to 8.5.

The majority of pH sensors probes work in similar ways. All liquid solutions are able to generate certain voltages depending on their Hydrogen ion concentration (pH). The sensor probes measure the voltage of the solution and in order to determine the pH, by using Nernst equation. This equation provides the relationship between voltage and Hydrogen ion concentration (pH). Alkaline solutions have a lower Hydrogen ion concentration than acidic solutions.

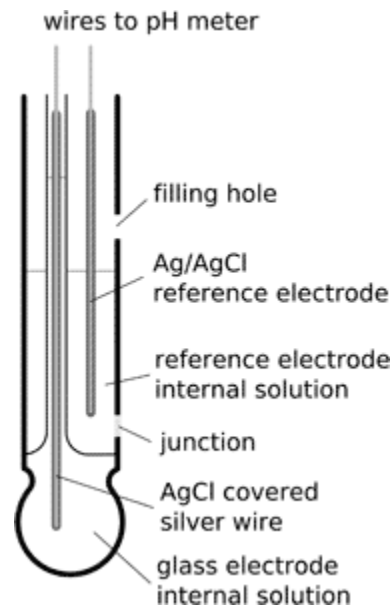

Figure 20 - pH probe diagram [13]

*Permission Requested

For our project we decided to use the most commonly available pH sensors. This type of pH sensors are a combination of electrodes that have both glass H⁺ ion sensitive electrodes and additional reference electrode conveniently placed in one housing.

Turbidity Sensor

Monitoring the water quality is one of the most important features for our project. Being able to determine if the filtering system is working correctly and producing water apt for consumption is essential. Along with the pH sensor, our design incorporates a turbidity sensor to determine the quality of the water. This sensor detects the turbidity or opaqueness of the water by measuring the number of solids in water.

A turbidity sensor probe operates by sending light into the water and detecting the light that is reflected back to the sensor. Since the particles residing in the water scatter the light, the more particles present in the water, the more light the sensor will detect.

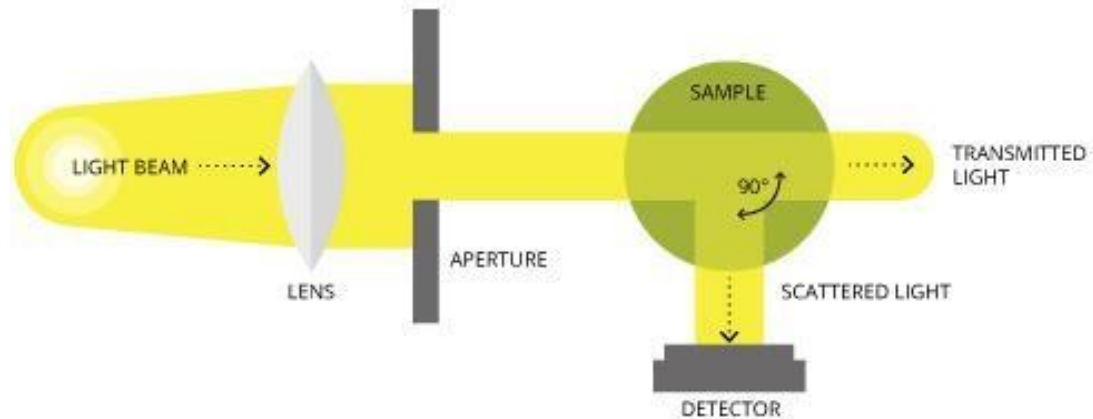

Figure 21 - Turbidity sensor mechanism diagram [14]

*Permission Requested

The majority of turbidity sensors available work in the same way. The sensor emits a light beam into the water, while a light detector is placed in a 90 degree angle from the light beam. The light detector measures the scattered light and calculates the number of suspended particles in the water using this information.

Leak Sensor

Our system includes water sensitive electronic devices that work in close proximity to water sources. It is imperative therefore, that the user be alerted of any leak that may compromise the electrical parts of the device. For this purpose, our design includes a leak sensor that will detect the presence of water in areas of the system where there isn't supposed to be any.

There are multiple different leak detectors that work in different manners. For this project however two types were taken into consideration: A light-based leak detector and a conductivity-based detector.

The light-based leak sensor works by emitting a light beam into its sensing surface. When there is no water leaking the light beam reflects off the surface of the sensor and is transmitted to the beam receiving part.

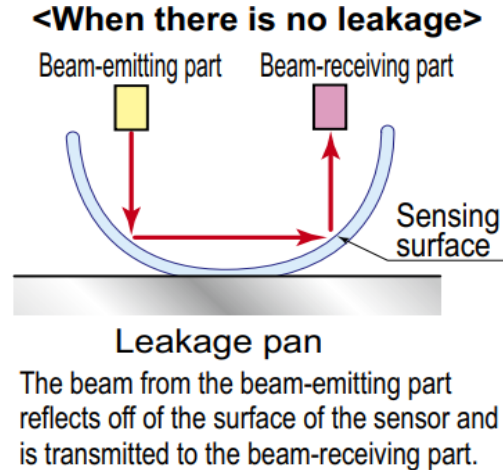

Figure 22 - Leak Sensor Mechanism Diagram 1 [15]

*Permission Requested

When a leak occurs, due to the capillary effect, the water sticks to the sensing surface. As the light beam from the sensor hits the sensing surface it is scattered through the liquid and does not reach the beam receiving part. When this happens, the sensor emits a signal to alert of the leak.

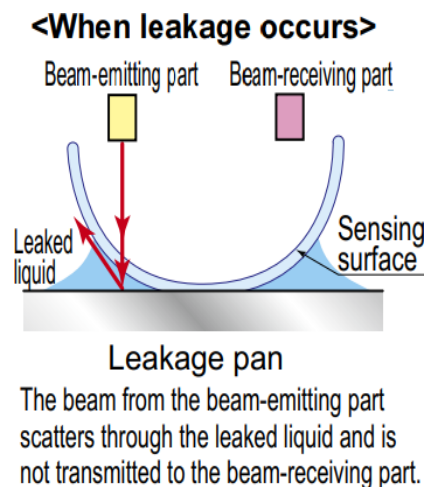

Figure 23 - Leak Sensor Mechanism Diagram 2 [15]

*Permission Requested

The conductivity-based sensor on the other hand works by relying as its name implies on the conductivity of water. This type of leak detector connects at its base

to form an open circuit. When the water from the leak reaches the sensor, it bridges the two contacts and changes the resistance. This causes an alert to be triggered.

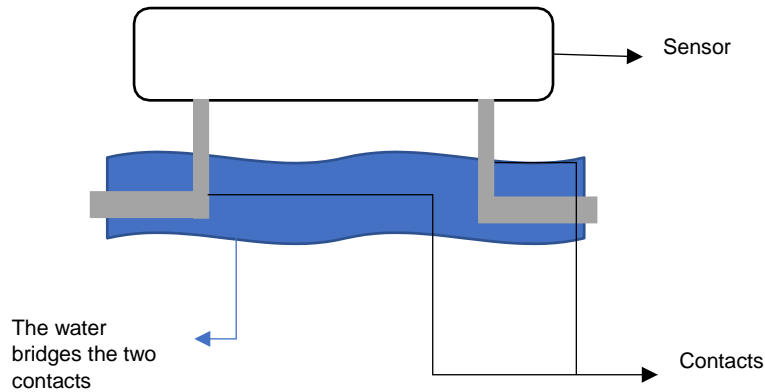

Figure 24 - Leak Sensor Mechanism Diagram 3

Sensor Type	Advantages	Disadvantages
Light-based Sensor	<ol style="list-style-type: none"> 1. Capable of detecting smaller leaks. 2. Detects leaks quicker. 3. Small size. 	<ol style="list-style-type: none"> 1. High price. 2. Harder to interface with MCU. 3. High power consumption.
Conductivity-based Sensor	<ol style="list-style-type: none"> 1. Moderate cost. 2. Easy to interface with MCU. 3. Lower power consumption. 4. Small size. 	<ol style="list-style-type: none"> 1. Can't detect smaller leaks. 2. Longer detection time.

Table 10 - Leak Sensor Comparison Table

There are factors that favor the use of the light-based leak sensor. First the method used on this type of sensor allows the detection of small amounts of water leaking on the system. This in turns lets the sensor discover leak quickly before they become worse. For a system as ours that places delicate electronics parts near water, this is extremely helpful since it may save those components from being damaged by the water.

The conductivity-based sensor on the other hand, has a significantly lower cost than the light-based sensor. While the light-based sensor has prices around \$156.60 the conductivity-based sensor can be bought at a fraction of that price at

\$37.40. Furthermore, this type of sensor also offers lower power consumption than the light-based ones, and is easier to interface with different microcontroller units. This makes up in part for its inability to detect smaller leaks than the other type of leak detector.

For this project we decided to use a conductivity-based sensor. Two major factors that were important in influencing this decision: the lower price and the lower energy consumption. While it is true that is important to detect leaks in the system quickly the light-based sensor consumes significantly more energy. Since we are using solar panels and a battery to power up our system, it is important to keep the energy consumptions low. This coupled with the fact the conductivity-based sensor is almost one third of the price compared to the other, motivated our decision for the sensor.

Water Flow Sensor

The filtering system in this project consists of a water pump that drives water through different types of filters. Each of these filters has a usable life that depends on amount of water that was filtered through them. By including multiple water flow sensors in the system, we can use the information collected from them to generate a better approximation of when the filters need to be changed. Moreover, these sensors may also allow us to locate leaks and obstructions in the system, by determining where the water flow has been reduced.

The most used water flow sensor consists of a water rotor and a hall effect sensor encapsulated in a valve body. When water flows through the rotor rotates. The speed of the rotor increases as more water flow across it. This change in speed is measured as a pulse by the hall effect sensor: therefore, calculating the flow of water.

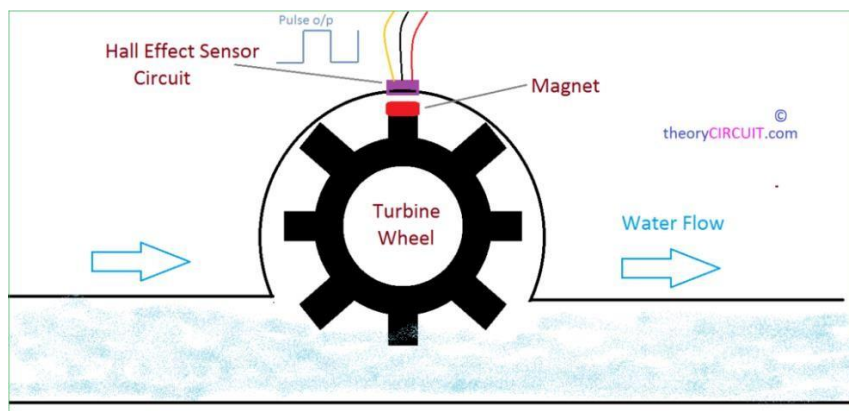

Figure 25 - Water flow sensor mechanism diagram [16]

*Permission Requested

3.2.8 Printed Circuit Board

There are two ways to implement our circuit design, with the use of circuit boards and printed circuit boards. Although breadboards allow easy manipulation of the circuit, they cannot be trusted. As we experienced in the lab sometimes the interconnections get loose or the inner connections of the breadboard don't function well.

To reduce these errors, we will use PCBs. In order to have our electronic components and sensors and power supply to be interconnected seamlessly, printed circuit boards (PCB) will be used to permanently connect the circuits. PCBs offer much more safety, secure connections and dependability. A PCB is a layered combination of a silkscreen, solder mask, copper and a substrate (FR4). FR4 is a Fiberglass-reinforced laminate sheet used as a substrate in PCBs. FR4 is more expensive than FR2 but it offers better features. It is heat/flame resistant and its ability to be used in vibrant settings the advantages include it can be stacked to multiple substrates. The combination and layering of these layers together allow for a circuit to be wired together without physically needing to use wires to connect them together like on a breadboard.

PCB Design

The Association Connecting Electronics Industries, also called IPC, is a trading company which aims to standardize the production and assembly requirements of electronic equipment. The company creates many of the standards used by electronic manufacturing industries. The standards the company created include: printed board, printed electronics, design standards, flexibility, assembly, electronic enclosures, embedded technologies, and commercial PCBs are required to follow a set of standards to ensure longevity and reliability of the product. The standard for printed board design is IPC-221B, which is explained in table.30, which lists the general requirements for component mounting and PCB designs. By following standards, the PCB for the project can help achieve desired design results. This will bring about the product's reputation, reliability, and profitability. Using international standards will also allow global usage without the problem of communication difficulty in the electronic industries around the world.

The first step in designing a PCB comes in the form of selecting the required parts for the project to make sure they function properly. Then, pick the right software to design the circuit. Our goal was to find efficient and user-friendly software to design our circuit. Also, the software should be accepted and adhere the design standards of the manufacturers. Here is a comparison of the software's.

Software	Cost	Features
Eagle Auto desk	>\$780 * free student edition	* Good support desk from AutoCAD * It is widely used, good support from online community. *Thousands of premade libraries *Almost supported by all manufacturers
Express PCB	Free	*Simple to design *Active online community *Open- source libraries *High quality files
OrCAD	~\$2300	*Powerful circuit simulation *Auto – routing system *Can create databases to store component values
PCB layout	Free	*Simple to design *Supported with most manufacturers

Table 11 - Comparison of Design Software

Based on the above table's comparison we decided to design our project with Eagle Auto desk software. Eagle auto desk provides an easy to interface platform with broad range of resources. We will design our circuit using their schematic or layout editor. Then we'll send it to a manufacturer for fabrication. And this schematic file will be used as a guide to create a PCB for our project. Since Eagle Auto Desk uses universal file for use with multiple manufacturing.

PCB manufacturing

After the design is completed in Eagle Auto Desk, the file was exported and sent to a manufacturing company. Then the manufacturing company will take the design and print out the circuit properly by designing each layer and component of the PCB precisely. After the manufacture confirms the board is functioning and conducting properly the board is sent back to the consumer for final completion of the board by soldering on the final components of the circuit.

We researched a couple of manufacturing companies. Since the cost of printing a PCB isn't expensive, most of the manufacturers were around the same range.

Osh park is a PCB manufacturing company, they accept Eagle Auto desk CAD designs. They have a competitive pricing at about \$5 per square inch for two-layer board. They are also relatively fast in shipping averaging less than 2 weeks. They also provide three copies for 4-layer boards for about \$10.

We also researched 4PCB manufacturing, they support PCB layout software at similar prices with Osh park, but for their faster delivery and minimal shipping fee we will pick Osh park as of now.

3.2.5 Voltage regulator

Another very important piece that will be used in the power supply is a voltage regulator. Voltage regulator as its name implies is a system designed to automatically maintain a constant desired voltage level. And the reason we need a voltage regulator is because of the variety voltage operating requirements of our circuit components. So, once the energy is stored in the battery from our solar panels, the voltage regulator will change the voltage from the battery to different voltage levels depending on each component's specification.

Without voltage regulation our circuitry will get destroyed, if there is not proper voltage regulation. Hence, a voltage regulator is common in electronic systems to provide voltage regulation and protection of our electrical components from raw currents produced from power supplies by means of feedback system.

In our project we have several sensors, gauges, microcontroller and a pump that require different operating voltages. And our selection of a voltage regulator will be based on these factors plus the power consumption, efficiency, cost and reliability of the component. Most regulators typically contain an Op-Amp, BJT transistor, a Zener Diode, resistors and some capacitors.

The op-amp helps to drive the BJT by giving it more current which helps to have a slightly higher output voltage. While the transistor in common collector mode helps to have a stable output voltage and function as a regulator on its own. Generally, there are two types of voltage regulators, linear voltage regulators and switching voltage regulators.

Linear regulators preferable in applications where:

- Simple/low cost solutions – good for low power applications with low outputs.
- Low noise/low ripple application – for noise sensitive applications such as radio devices

- Fast transient applications – since the feedback loop is internal, no external compensation is required.
- Low dropout applications - for applications with similar input and output voltages.
- They have very low efficiency of about 40%. So, they are not ideal for our project.

Switching Regulator

As we have seen above linear voltage regulators provide solutions to low power applications where there is primarily low budget and the above-mentioned preferences. But they are not the common choice for higher power applications. The reason is many linear regulators are about 50% efficient; most of their power is dissipated as thermal energy. They can be boosted to a little higher efficiency by adding components, but it comes at a higher cost and complexity. This is the reason switching voltage regulators comes in handy. Switching voltage regulators have higher efficiencies of up to 85%, and they are better to work with for applications that require wide range of input voltages.

There are generally three types of switching voltage regulators, the step up, step down and the inverter voltage regulators. For our project we explored the step up and step-down voltage regulators.

Buck Converter

A Buck converter is a step-down voltage regulator that drops a DC voltage to a lower DC voltage with the same polarity. So, it is a DC-to DC power converter. This converter uses an inductor to drive a current into a load resistor to get the desired output voltage and to maintain it at the desired amount. A capacitor is used to be charged and help keep the inductor current constant across the load resistor to keep the voltage stable. We'll need this converter to feed our low powered components like microcontrollers, gauges and sensors.

Switching regulators are based upon using a pulse where its duty cycle is varied to maintain a constant voltage at its output.

Buck converters do an excellent job often up to 90% efficient. This makes them useful for our task in delivering the required voltages for our components.

Boost Converter (step up)

This converter is like the buck converter except it outputs higher voltage than the input. The reason we were interested in step up regulator is we have components, like the pump that require higher operating voltages. This step-up converter is a

DC-to-DC voltage converter that lowers the output current as well. One of the functionalities of this converter is that, the inductor on the input side resists fast variations in the incoming current. The inductor stores electromagnetic energy when there is no input, and discharges the switch is closed. A capacitor is added in the output. This capacitor is large enough to assume a constant RC time. This results in a constant voltage output.

In our project, we are going to suck dirty water to our filtration unit with a pump and dispense the filtrated clean water on the other side. We decided to use this to power the pump. Since we are using solar to harvest power. We could not afford to use linear voltage regulator due to its low efficiency. Also, the use of the ups120 diode or others with similar can be used can be used to insure stability.

And unlike linear voltage regulators, switching voltage regulators are efficient. They do not dissipate as much power. We can see the following figure, which is the efficiency chart of the above boost converter Vs the load current to see the difference of efficiency with linear voltage regulators.

We can observe how efficient this regulator is from the following chart. It is the efficiency Vs Load current of the above figure. Likewise, it can be compared to the linear voltage regulator efficiency chart and hence our reason of picking this converter over linear voltage regulator.

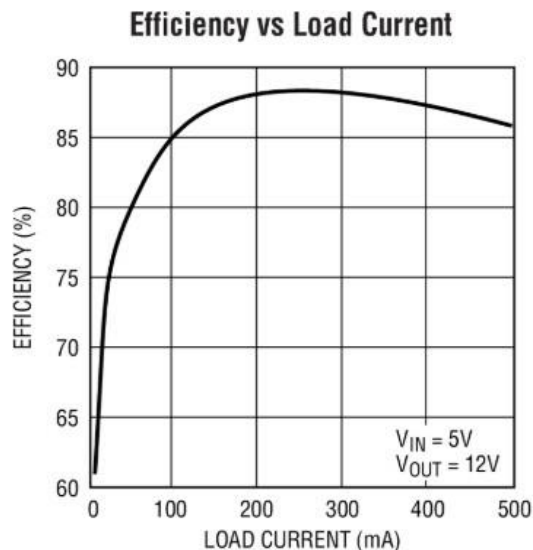

Figure 26 - Efficiency Vs Load Current [17]

*Permission Requested

Our solar panel provide about 100W, Dc charging output of 18V/5.4A, and open circuit of 16-18 volts. For our step-down voltage regulation, we compared the TPCS63070 switching voltage regulator lab with LM2576 switching voltage

regulator. We compared them both for converting 12V to 5V. The information was gathered from Texas instruments datasheets provided for them.

TPS63070

The TPS63070 is a buck-boost switching regulator that takes an input range from 2V to 16V and regulates that to 2.5V to 9V. It also has an output current of 2A. According to its' datasheet, this device also has a 95% efficiency and a quiescent current of 50 microamps. It is also very low cost, with prices as low as \$1.15 for large quantities to \$2.88 for smaller quantities on the TI website. However, it is large component with dimensions being 2.5mm by 3mm.

LTC3119

The LTC3119 is a switching regulator offered by the company Linear Technology. Its input voltage can vary from 2.5 to 18V and the output voltage from .8V to 18V. After it is started up, "operation is possible with input voltages as low as 250mV." This will prove very advantageous for our project because this has implications, we will still be able charge a battery even after the pressure applied to the piezoelectric transducer has stopped. The downside is that this component is very large (4mm by 5mm) and would take up almost a quarter of our PCB.

Feature	TPS63070	LM2576	LTC3119
Operating Voltage	2.5V – 18V	4-40V	2.5-16V
Max O/P Current	1.5A	3A	5A
Output options	Fixed	Adjustable	Adjustable
Operating temperature	0-125°C	-40 - 125°C	-40 - 125°C
Switching frequency	N/A	42-63KHz	4KHZ – 2MHz
Efficiency	~ 91%	77%	~90%
Unit price	\$2.88	\$0.46	\$1.87

Table 12 - Comparison Candidate Voltage Regulators

As we can see from the above comparisons in the table, although the LM2576 is double the price of LM780, the price is low in general for these components. But the efficiency is almost double of the linear voltage regulator, and considering the temperature, operating voltage and higher load current, the LM2576 has more advantages of the linear voltage regulator, and hence more flexibility and possibilities.

The fixed version of LM2576 will be used for our design. The circuit shown in the next figure is from Texas instruments datasheet. Here the output voltage is set at

a constant 5V with 18V input. The good thing about this design is the maximum load current can be varied by changing the value of the inductor (L1). It will produce about 5V output with max load current of 3A. Using this way we can change the value of the load current depending on the specification on or microcontroller.

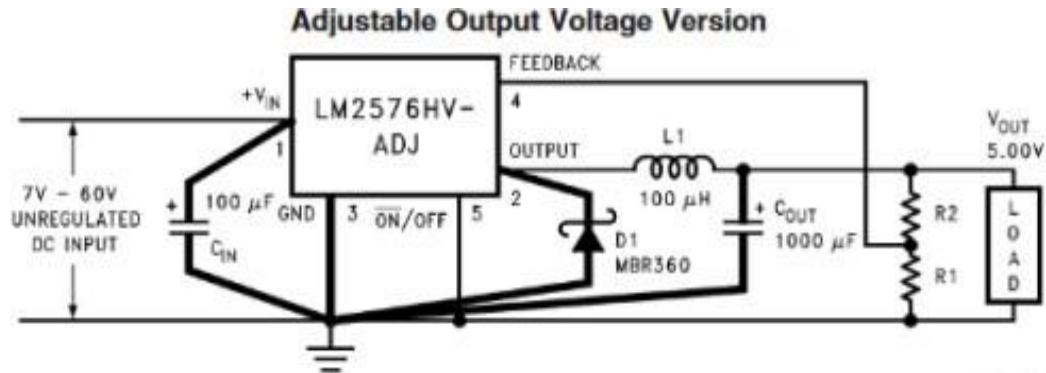

Figure 27 - Schematic of LM2576 ADJ Voltage Regulator (5V output) [18]

[Courtesy Texas Instruments data sheet]

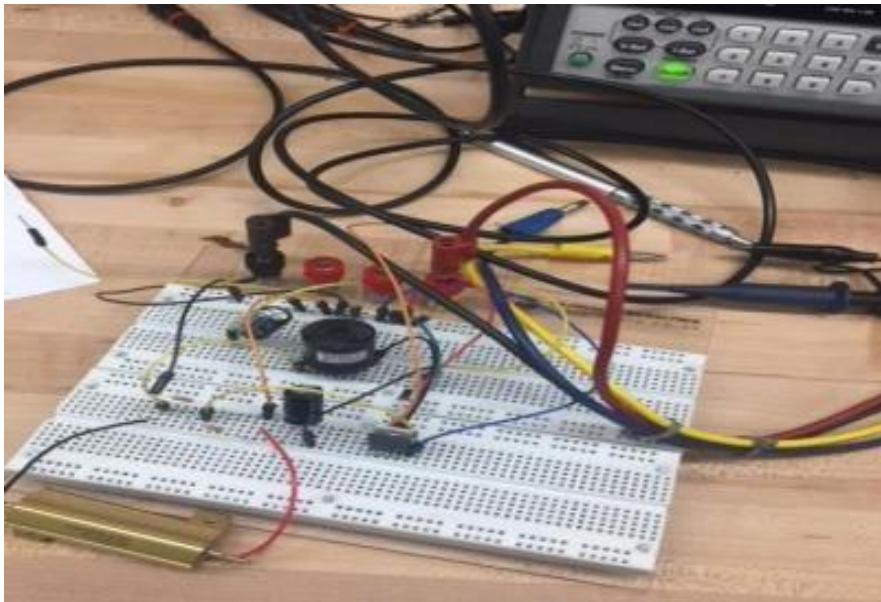

Figure 28 - Circuit for the LM2576 ADJ Voltage Regulator

As we can see from the circuit, we tried it with the low tolerance load resistor found in our lab to get the accurate reading. The good thing about this design is the maximum load current can be varied by changing the value of the inductor (L1). It will produce about 5V output with max load current of 3A. Using this way we can change the value of the load current depending on the specification and requirement of our electrical components like the microcontroller and the pump.

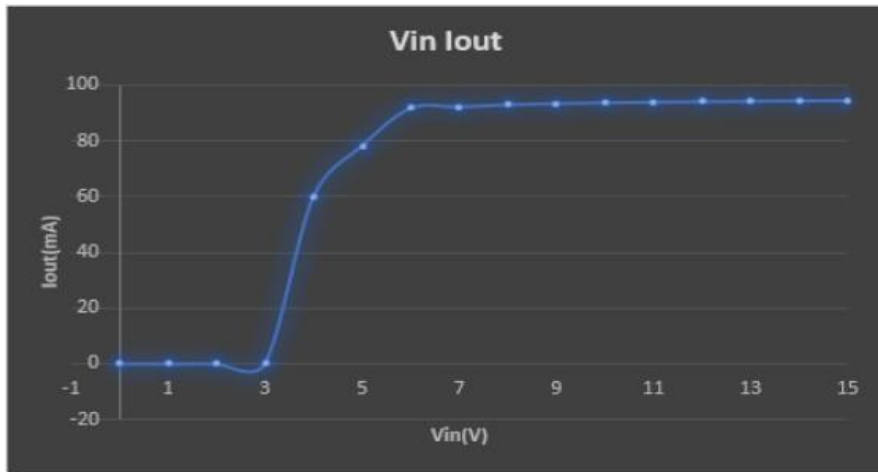

Figure 29 - Plot of the Input Voltage and Output Current.

We also compared the efficiency of our output to the one compared by its datasheet.

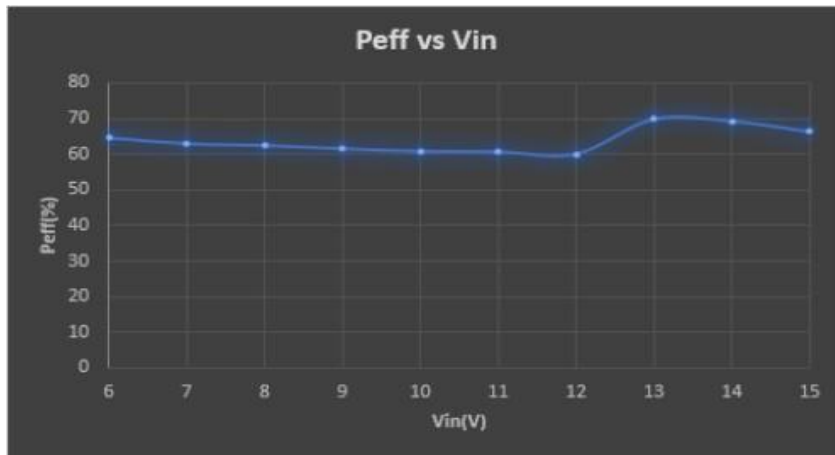

Figure 30 - Plot of the Output Efficiency P_{out}/P_{in} as a Function of V_{in}

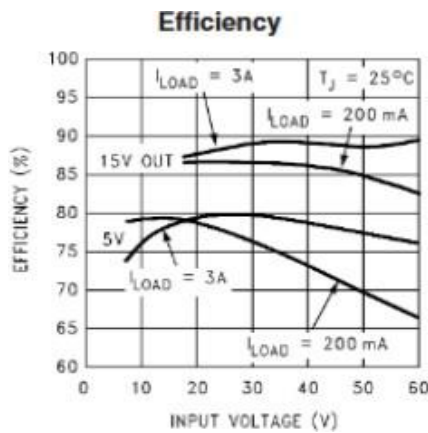

Figure 31 - Efficiency of LM2576 ADJ From its Datasheet[18]

[Courtesy Texas Instruments data sheet]

3.3 Strategic Component and Part selection

In this section, we will talk about the specific parts and describe each and every one of them and the reasons why we specifically chose them. We will also discuss the advantage and disadvantages and provide details as of why this specific component suits our project the best.

3.3.1 Solar Panels

After the detailed description of the different types of solar panels in section 3.2, we decided that the best solar panels for our water filtration system would be the thin-film cells, the flexible panels. Since one of the main characteristics of our senior design project is to make it lightweight and portable, it is a better choice for our water filtration system. We also need the flexible panel to generate enough power from the sunlight in order for our system to work. We researched thin-film solar panel for our water filtration system device and we found the different types of panels, and arranged from panels that are classified among the following: power, peak voltage, size, weight and cost. The following table describes all the different solar panels sold by Voltaic Systems and are listed below:

Panel Model	Panel Power (W)	Panel Peak Volt (V)	Panel Size (in)	Weight (lbs.)	Cost
1.0W-PANEL	1.2	6.5	3.5 x 4.4 x 0.2	0.16	\$19
2.0W-PANEL	2.2	6.5	5.4 x 4.4 x 0.2	0.28	\$29
3.5W-PANEL	3.5	6.5	8.3 x 4.4 x 0.2	0.34	\$39
6.0W-PANEL	6.0	6.5	6.9 x 8.7 x 0.2	0.56	\$59
9.0W-PANEL	9.2	6.5	8.7 x 10.1 x 0.2	0.79	\$79
9.0W-18V-PANEL	8.9	19.4	8.7 x 10.1 x 0.2	0.79	\$89
17.0W-PANEL	17.6	18.9	10.8 x 15.5 x 0.2	1.5	129
5.5W-MB	5.75	6.12	6.9 x 8.7 x 0.2	0.56	35
10.0W-MB	9.59	5.64	8.7 x 10.2 x 0.2	0.73	65
9W-18V-MB	7.78	16.4	8.7 x 10.2 x 0.2	0.73	65

Table 13 - List of Different Types of Solar Panels

Compare to other solar panels company, Voltaic Systems says that it has high efficiency monocrystalline cells of nineteen percent. With that being said, it means that the solar panel is able to convert nineteen percent of the sunshine into energy, electricity. As of today, the highest efficiency solar panel can attain about twenty three percent efficiency.

Most solar panels available on the market have somewhere between fifteen and eighteen percent efficiency. Considering our small, portable and lightweight water filtration system, we can say that compare to most large residential and commercial solar panels that deliver around the same efficiency, the small solar panels that Voltaic Systems offer are a very good choice.

With every solar panel bought, Voltaic Systems includes 10.2 inches output cable in length that can be connected to the battery. Also, all their small solar panels are waterproof and have a better warranty than most other companies.

Renogy, another company that sells solar panels, has a variety of foldable and unfolded solar panels at a competitive price. However, they do not provide the percentage of efficiency monocrystalline cells; it does not include output cable to connect to the battery and does not provide any information regarding the warranty on all of their small solar panels. Also, Renogy does not offer a variety of small solar panels that would fit our water filtration system.

Another solar panels company called Goal Zero Venture 30, also offer small solar panels for our water filtration system. However, the weight of most of their solar panels is more than the weight of the solar panels from Voltaic Systems. Also, they offer a warranty of only twelve months compare to Voltaic Systems who offer two years warranty on most of their small solar panels. The price of Goal Zero's lightweight and portable solar panels is double compare to the price to Voltaic Systems.

After comparing multiple solar systems company, we can conclude that Voltaic System's company is the best choice for our water filtration systems because it has competitive price compare to Renogy and Goal Zero Venture 30, charge about twice as much compare to Renogy.

Second, it also has a better warranty, a better efficiency monocrystalline cells and in terms of weight, it is a lot lighter than the other lightweight solar panels that the other companies are offering. Compare to Renogy, the other companies have a large variety of larger size solar panels that unfortunately would not fit with our water filtration system.

3.3.2 Voltage Regulator

Our solar panel provide about 100W, Dc charging output of 18V/5.4A and an open circuit of 16-18 volts. For our step-down voltage regulation, we compared the familiar LM317 switched linear voltage regulator that was used in our electronics-2 lab with LM2576 switching voltage regulator. We compared them both for converting 12V to 5V. The information was gathered from Texas instruments datasheets provided for them.

Feature	LM7317	LM2576
Operating Voltage	7.5V – 35V	4-40V
Max O/P Current	1.5A	3A
Output options	Switched	Adjustable
Operating temperature	0-125°C	-40 - 125°C
Switching frequency	N/A	42-63KHz
Efficiency	~ 71%	77%
Unit price	\$1.19	\$0.46

Table 14 - Comparison of LM7805 and LM2576 Voltage Regulators

As we can see from the above comparisons in the table, although the LM2576 is double the price of LM7805, the price is low in general for these components. But the efficiency is almost double of the linear voltage regulator. And considering the temperature, operating voltage and higher load current the LM2576, it has more advantages of the linear voltage regulator, and hence more flexibility and possibilities.

The fixed version of LM2576 will be used for our design. The circuit shown in next figure is from Texas instruments datasheet. Here the output voltage is set at a constant 5V with 18V input. The good thing about this design is the maximum load current can be varied by changing the value of the inductor (L1). It will produce about 5V output with max load current of 3A. Using this way we can change the value of the load current depending on the specification on or microcontroller.

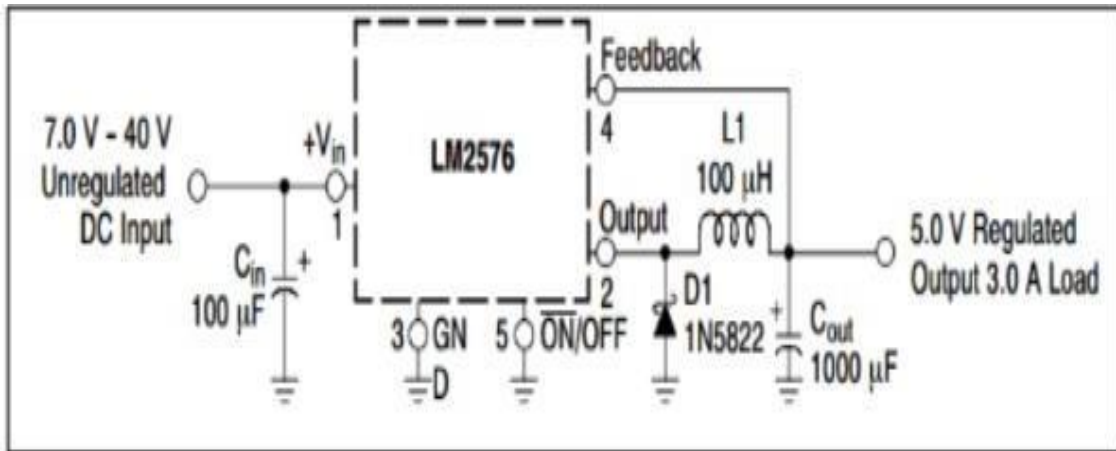

Figure 32 - Schematic of LM2576 Voltage Regulator (5V output)[18]

[Courtesy Texas Instruments data sheet]

3.3.3 Microcontroller

ATmega328P

The Atmega328 is a very popular microcontroller chip produced by Atmel. It is an 8-bit microcontroller that has 32K of flash memory, 1K of EEPROM, and 2K of internal SRAM. It has a 23-pin size and uses I2C, UART, and SPI as its communication protocols. This microcontroller is commonly used by Arduino Uno boards and it cost around \$2 each.

MSP430FR6989

The MSP430FR6989 is a very popular 16-bit microcontroller made by Texas Instrument, it uses I2C, UART, and SPI as its communication protocols, and has an $100\mu\text{A}/\text{MHz}$ active mode. It has 2 KB of RAM, 128 KB FRAM, supports 5 timers for refresh and interrupt sensors, and has 83 GPIO. The price of this microcontroller is around \$11. This microcontroller is a good option for our project since it can support all the different sensor and functionalities that we want to implement in our device.

ATSAMG51

This microcontroller is commonly used by Raspberry Pi boards. It has 256 KB of memory, 64KB of RAM, supports 38 GPIO pins, and uses UART, and SPI as its communication protocols. Its low power mode has a drain of $103\mu\text{A}/\text{MHz}$ running Fibonacci in SRAM, and has a wake up time of less than $3.2\mu\text{s}$. Compared to the others microcontrollers this one has superior RAM and memory and is all around a better option. The price of this microcontroller is around 4\$.

A comparison table is shown below, with all the main features of three microcontrollers. Each one has both advantages and disadvantages when compared to each other but for the purpose of this project any of the three options are viable choices.

	ATSAMG51	MSP430FR6989	Atmega328P
Memory	256 KB	128 KB	32 KB
RAM	64 KB	2 KB	2 KB
Pin Size	38	83	23
Communication Protocols	UART, I2C, SPI	UART, I2C, SPI	UART, I2C, SPI
Low-Power Mode	103 uA/MHz	101.25 uA/MHz	0.75 uA/MHz

Table 15 - Microcontroller comparison

This microcontroller satisfies the minimum requirements and necessities of our project. However, our group has decided to use the ATmega328P for this project because of its pin size, its low power modes, and the familiarity of the team members with this specific microcontroller. Shown below is the Functional Block Diagram for the chosen microcontroller.

3.3.4 Remote Connectivity

Having a connection between the water filtration system and the user's phone is an essential part of this project. In order to exchange data between both of these devices remote connectivity technology is needed. Nowadays the most popular wireless technologies available are Bluetooth and Wi-Fi. However, as explained in the previous section our team has decided to use Bluetooth technology for various reasons.

Lack of power sources and no internet connection are problems that we want to solve in order for the users to be able to manipulate and use our device. Even though Bluetooth connection has a lower range and slower data sharing speed when compared to Wi-Fi, it is a reliable technology that meets the needs of our device.

The first Bluetooth module that we considered for our device is the HC-06 Wireless Bluetooth Transceiver Module. The HC-06 module is the most popular module used for Bluetooth connection, once it is paired to a master Bluetooth device such

as PC, smart phones and tablet, its operation becomes transparent to the user. It has an input voltage of 3.6V – 6V and its unpaired current is about 30mA. Its range is around 10 meters, with a band frequency of 24GHz, and include a LED light that indicates the connection status. The cost of this module is around \$5.35.

The second option is the HC-05 Bluetooth Board Module. When compared with the HC-06, we can say that this module has pretty much the same characteristics. It has an input voltage of 3.6V – 6V and its unpaired current is about 30mA. Its range is also around 10 meters, with a band frequency of 24GHz. However, the HC-05 has 6 header pins and another important difference is that this module can either be a master or a slave. The cost of this module is around \$7.25.

	HC-05	HC-06
Dimension	26.9mm x 13mm x 2.2 mm	26.9mm x 13mm x 2.2 mm
Operating Voltage	+3.3V to +6V	+3.3V to +6V
Security	Authentication and encryption	Authentication and encryption
Operating temperature range	-20 ~ +75Centigrade	-20°C to +55°C
Bluetooth protocol	Bluetooth Specification v2.0	Bluetooth V2.0 protocol standard
Pins	6	4
Modes	Master or slave	Slave

Table 16 - Bluetooth modules comparison

Taking into account this specification and the necessities of our project, we decided that the HC-06 Bluetooth module is the better option. We only need the module as a slave, it has a smaller number of pins, and its cost is also less than the HC-05 module.

3.3.5 Water Pump

As explained in section 3.2 our group decided to use transfer water pumps instead of submersible pumps. Submersible pumps are not convenient for the design we have plan for our device since if we were to use that type of pump the portability of the device would be compromised. Another advantage of the transfer water pump is that I can be easily maintained, and its status can be check constantly by the different sensor in our device.

When looking for different options of transfer water pumps five important aspects came to mind: cost, size, power consumption, weight, and flow rate. The ideal cost for the water pump to be used in our device should be between the ranges of \$5 to \$25. Its power consumption has to as low as possible since the use of solar power is an important constraint to be considered in our project.

When it comes to weight and size both are determinant factors that could compromise the portability of the device, so both small size and low weight would be ideal for the design of our filtration system. Finally, a good amount of flow rate would be convenient for the user since the amount of filtered water per minute depends on this.

Table 17 compares the options that meet the requirements we previously discussed. All the options shown in that table were considered carefully to choose the best possible option for our project.

Pump	Cost	Voltage	Current Draw	Liters per minute	Size
Bayite 12V DC Fresh Water Pump Version 1	\$24.99	6-12 Volts	5.0AMP	4.5 L/Min	16.5cm(L) x 10cm(W) x 6cm(H)
Bayite 12V DC Fresh Water Pump Version 2	\$17.99	6-12 Volts	3.0AMP	4 L/Min	15.5cm(L) x 10cm(W) x 6cm(H)
Amarine-made 12v Water Pressure	\$16.48	6-12 Volts	1.7 Amp (max. 2.7 Amp)	4.3 L/min	170mm (L) x100mm(W) x 67mm (H)
Spires 12V DC Fresh Water Pump	\$13.99	6-12 Volts	2.5 Amp	4.5 L/Min	7(L) x 3.9(W) x 2.9(H) inches
Acouto 12V 60W Electric Portable Transfer Pump	\$29.99	6-12 Volts	5 Amp	4.5 L/Min	11mm(L)x 8mm(W)X 6mm(H)
Balance World Inc Agricultural Electric Diaphragm Water Sprayer Pump	\$11.39	6-12 Volts	2.0A	3.5L/Min	6.7(L) x 3.9(W) x 2.4(H) inches

Table 17 - Transfer Pump Comparison

After analyzing the different options, the groups decided that the Amarine-made 12v Water Pressure would be more beneficial for our project since the cost, the amount of liters per minute it produces, and its size are all a great fit for the water filtration system.



Figure 33 - Amarine Made 12V Pump [19]

*Permission Requested

3.3.6 Water Filters

As explained in the previous section choosing the filters for this project required a lot of research. At the end our team decided that the combination of four different type of filters to ensure a good quality product would be the best option to take. The types of filters that we choose for this project are a sediment filter, a pre-carbon filter, an ultrafiltration device, and an ultraviolet filter.

To select the best filter for each of these types we considered the filter price, size, and lifetime. The filters size and lifetime are very important since both of these characteristics could compromise the design and quality of the water filtration system. The lifetime of the filters should not be less than 12 months since replacing the filters too frequently represent a problem for people in developing nations which is our target demographic. If the filter is too big the device would not be as transportable as desire which would represent a problem when traveling long distances with the product.

Sediment Filter

Sediment Filter	Size	Cost	Lifetime
Microline CTA/TFC 5 micron Pre-Sediment	10" x 2"	\$15	12 months
33210 / S7011 Microline Whole House Sediment Filter	10" x 2"	\$5	3 months

Table 18 - Sediment Filter Comparison

Both sediment filters provide good quality filtration and are reliability small. However, the lifetime of the 33210/S7011 sediment filter does not meet our

minimum requirement, so we decided to use the CTA/TFC sediment filter for the device, since this provides a lifetime of 12 months.

Pre-carbon Filter

Pre-carbon filter	Size	Cost	Lifetime
LASCO 37-1821	2" x 10"	\$14.99	6-Months
Membrane Solutions Carbon Water Filter	10" x 2"	\$9.99	12 months
T33 Inline Coconut Grade Activated Carbon	10" X 2"	\$7.99	2 years

Table 19 - Pre-carbon Filter Comparison

After careful consideration we decided that the T33 Inline Coconut Grade Activated Carbon filter is the most adequate for our filtration system since its lifetime is significantly longer than the other two filters.

Ultrafiltration

Ultrafiltration	Size	Cost	Lifetime
BRISTI LP-1400P Water Filter	7 x 2 x 2 inches	\$21.99	6 months
LifeTech RO Last Stage T33 Ultra Filtration Cartridge - Filter	11.6 x 3.1 x 2.4 inches	\$19.00	18 Months

Table 20 - Ultrafiltration Filter Comparison

The ultrafiltration device that we choose after comparing both options was the LifeTech RO Last Stage T33 Ultra Filtration filter since its lifetime is longer and the price is less than the Bristi filter. Even though, the Bristi filter was smaller the team considered that the lifetime of the filter was a more important aspect, since the water filtration system we are designing is intended for developing countries that may not be able to change filters in a long period of time.

Ultraviolet Water Purifier

Ultraviolet Water Purifier	Size	Cost	Lifetime	Power consumption
Express Water – Ultraviolet Water Filter	12" x 2"	\$69.99	6 months	12 W
Boeray Ultraviolet Light Water Purifier	17.8 x 4.9 x 3.9 inches	\$53.99	12 months	6W

Table 21 - Ultraviolet filters comparison

After comparing both ultraviolet filters, the team decided to use the Boeray Ultraviolet Light Water Purifier. This filter power usage was substantially less than the other UV filter. The power usage of this filter is an important part of our project since one of our biggest constrains is the use of solar energy. If the UV filter were to consume an important amount of power the operability of the filtration system would not be as long as intended. Another advantage of the Boeray filter is its lifetime which doubles the lifetime of the other option.



Figure 34 - Boeray Ultraviolet Light [20]

3.3.7 MicroSD Card Module

For our system we decided to include a MicroSD card so that we could store the data from the sensors. Although microcontrollers have internal memory it is extremely small. This does not work for our system because we require long term data gathering for some of our smartphone application functions.

Our water filtration device was designed with the objective of providing access to safe drinking water to people in developing nations. Since the intended use of the device is in remote locations where people may not have access to smartphones, the system is meant to be able to operate without the smartphone application. However, we decided to include an app that would allow someone with a smartphone to access the data gathered from the systems sensors. This would allow the distributor or other users of the device to determine how much it has been used, how well it has operated, run diagnostics in case something is not working properly, or estimate the amount of time the filters will be operational. Because the distributor may not check regularly on each device, the device must be able to store the data for long periods of time. This is impossible to do with the internal memory of the microcontroller unit, prompting our decision to include a microSD card module.

MicroSD card are easily obtainable and for a really low price you can acquire one with 2 GB of memory. This is a considerably big amount of storage for our intended use. With that amount of memory, we can store months of data without any problem. For this reason, the more significant decision we needed to make was what type of microSD card module we would get.

There are multiple cheap options for this module, but we narrowed it down to two: Adafruit MicroSD card board+ and the DFRobot MicroSD module. Both are similar but the Adafruit has a voltage regulator that allows it to work with 3V or 5V. The Adafruit product also provide a faster read/write access and is prone to less problem since it doesn't use resistors but a level shifting chip.

MicroSD card module	Advantages	Disadvantages
Adafruit MicroSD card board+	<ol style="list-style-type: none"> 1. Voltage regulator allows operation in 3V or 5V 2. Faster read/write access 3. Level shifting chip is less prone to problems 	<ol style="list-style-type: none"> 1. Slightly more expensive
DFRobot MicroSD module	<ol style="list-style-type: none"> 1. Functionality is enough for our needs 2. Cheaper 	<ol style="list-style-type: none"> 1. Slower 2. Works only at 5V

Table 22 - MicroSD Card Module Comparison

Although the DFRobot MicroSD module is cheaper and has all the necessary functions for our system, we decided to use the Adafruit MicroSD card board+, since the price difference is only less than 3\$ and its advantages over the other module make it more attractive and time resistant.

3.3.8 LCD Display

As we mentioned it before, our water filtration device was designed with the purpose of working in remote regions where people have difficulty accessing drinking water. This also means that many of the users of our system may not have access to a smartphone to use our application. For this motive we decided to include an LCD display that would allow user to send some of the readings from the sensors. This screen will show the pH and turbidity of the filtered water to let the user know that the water is safe to consume. The display will also show the water flow through the filters so that the users know how much water is being filtered. This screen will also show error messages in case any of the sensors' values go outside certain range. This will alert the user if the filtered water is not safe for drinking, if the water flow or temperature is to low or high or if there is a leak.

There are multiple types of LCD displays that vary in size, color of display and price. Before comparing among specific models, we decided to narrow our options by selecting a particular size and display color. For the size since we needed to be able to show different data from the sensors and try to be as specific as possible when displaying error messages. This allowed us to eliminate any screen smaller than 16x4 since they would not allow the display of all the necessary information. We also decided against using big displays since these are more expensive and consume more energy. After checking the amount of characters and averages prices from the remaining display we decided to go with a 20x4 size display.

Although the 16x4 also worked for us, the 20x4 wasn't that expensive in comparison and provided more flexibility in what we could show on the screen.

Regarding color of display and text, for our system the aesthetics of the display weren't as important as the price. Color display are much more expensive than the others and are unnecessary for our project, so we didn't consider them in our selection. After looking at different display color we noticed that the cheaper ones were those with a green background and black text, and those with blue background and white text. This motivated our decision to compare displays with these characteristics

Display Model	Working Voltage	Price \$	Operating Temperature
LVD – 09568	5V	29.95	-20°C to 70°C
SunFounder LCD Module	5V	12.99	-10°C to 60°C
Adafruit Standar LCD 20x4	5V	17.95	-10°C to 60°C
MOP-AL204A	4.5V – 5.5 V	24.85	-20°C to 70°C

Table 23 - Display Model Comparison

Among these options we decided to go with the SunFounder LCD Module. We came to this decision since this particular LCD display satisfies all our system's needs and is the cheapest among all the other modules.

3.3.9 Sensors

The selection of the specific model and manufacturer of the sensors that would be used in this project was extremely important. Our water filtration system relies on multiple sensors, each of these sensors is offered in different models by multiple manufacturers, with different specifications and capacities. In our decision process for these sensors we made sure that each of our selections had the necessary functions for our project while also making sure to keep the prices as low as possible to keep the system affordable for people in developing nations.

Turbidity Sensor

Being able to determine if the filtering system is working correctly and producing water apt for consumption is essential. Along with the pH sensor, our design incorporates a turbidity sensor to determine the quality of the water.

The different models of turbidity sensor available for purchase offer similar characteristics and prices. The prices oscillate from \$7.50 to \$9.90. Their main difference lies on their operating and storing temperature ranges. After comparing different models and manufacturers we narrowed our option to four different turbidity sensors. The SEN0189, the TSD-10, the TST-10 and the TSW-10 turbidity sensors.

Turbidity Sensor Model	SEN0189	TSD - 10	TST - 10	TSW - 10
Operating Voltage	5V	5V	5V	5V
Operating Current	40mA (max)	30mA (max)	30mA (max)	30mA (max)
Insulation Resistance	100MΩ (min)	100MΩ (min)	100MΩ (min)	100MΩ (min)
Operating Temperature	5°C – 90°C	-10°C – 90°C	-10°C – 90°C	-30°C – 80°C
Storage Temperature	-10°C – 90°C	-20°C – 90°C	-120°C – 90°C	-10°C – 80°C

Table 24 - Turbidity sensor comparison table

All these models of turbidity sensor offer remarkably similar specifications for similar prices. All of these sensors have the same operating range, the same insulation resistance and except for one, all of them also have the same operating current.

The main differences between the models lies on their different operating and storage temperature of their sensors. The TSD-10 sensor offers a balance range for its operating and storage temperature. It allows for higher maximum operating and storing temperatures than the TSW-10 model, and a slightly lower minimum storage temperature.

The TST-10 is resistant to storage in surprisingly low temperatures, however this is an extreme value in which there is almost zero chance that our system will be stored.

The TSW-10 model can operate in lower minimum temperatures than the rest of the turbidity sensor, but in contrast it has a lower maximum temperature for both storing and operating. Same as with the previous model it is highly unlikely that

this system will need to operate in such low temperature. Furthermore, it is more likely that some cases will present themselves in which the sensor may be forced to operate in higher temperatures, making the lower maximum temperatures a disadvantage. This make this sensor model the less practical for our system.

Lastly, the SEN0189 offers a balanced storage temperature range, but has higher minimum temperature for operating. However, this is not a detrimental factor for our particular system, since it doesn't require such low minimum operating temperature as the other sensors provide.

Taking into consideration that the minimum operating and storing temperatures required for our system aren't a low as the ones provided by these sensors, and that the maximum temperatures where similar, the deciding factor in the selection of the sensor became the operating current. The SEN0189 provides a slightly larger maximum operating current and works in an appropriate temperature range for its intended use.



Figure 35 - SEN0189 Turbidity Sensor [21]

*Permission Requested

pH Sensor

As was mentioned before, our water filtration system includes a pH sensor to allow the user to determine if the filtered water has a pH that makes it safe to consume. We decided to use in our device the most commonly available pH sensors, that work by using a combination of electrodes that have both glass H⁺ ion sensitive electrodes and additional reference electrodes conveniently placed in one housing.

There are multiple models of pH sensor available for microcontrollers. The prices for these sensors vary greatly from around \$29.50 on some of the more economical to approximately \$72.6 on more expensive models. However, there is

little difference on their overall performance. The main difference between the models, apart from the price, is the necessary supply voltage and the lifespan of the probe.

pH sensor model	Advantages	Disadvantages
SEN0161	<ol style="list-style-type: none"> 1. Lower cost. 2. Easy to use. 	<ol style="list-style-type: none"> 1. Short lifespan (6 months). 2. Doesn't support long immersion. 3. Only the tip pH the probe can be immersed in water. 4. Only 5V supply
SEN0161-V2	<ol style="list-style-type: none"> 1. Medium Cost. 2. Wide voltage supply. 3. Average lifespan (6 months – 7 months) 	<ol style="list-style-type: none"> 1. Doesn't support long immersion. 2. Only the tip pH the probe can be immersed in water.
SEN0169	<ol style="list-style-type: none"> 1. Longest lifespan (2 years) 2. Whole probe can be immersed in water. 3. Supports long immersion. 	<ol style="list-style-type: none"> 1. Expensive. 2. Only 5V supply.

Table 25 - pH sensor model comparison

The SEN0161 probe is the most affordable of the models. It is easy to use, but its low price comes at the cost of a shorter lifespan than the other two. The probe is also not waterproof, and it only accepts a 5V power supply.

The SEN0161-V2 is an improved version from the previous models and offers a couple of advantages at an increased price. The lifespan of the robe is slightly extended, and it accepts a wide voltage supply range.

The SEN0169 presents multiple advantages over the other two models. However, the completely waterproof probe and long immersion support, despite being useful attributes, are not essential for the whole device. Only its longer lifetime is a major advantage over the other models, and it comes with a higher price. Since one of the major requirements for our system is affordability, so that it can be distributed to developing nations, the higher price is a major drawback for the use of this probe.

Considering the elevated price of the SEN0169, and its lack of any other essential characteristic compared to the other models, the decision was narrowed down to

the other two models for the system. The SEN0161-V2 offers a 3.3V to 5V voltage supply range and longer lifespan over the SEN0161. However, our microcontroller unit operates with 5V so it is not necessary to have the wider range in the sensor, and the lifespan was only slightly longer than the other model. These factors coupled with the lower price, that help keep the system more affordable for the user, make the SEN0161 a better fit for our system.



Figure 36 - SEN0161 pH sensor probe [22]

*Permission Requested

Water Flow Sensor

The filtering system in this project consists of a water pump that drives water through different types of filters. There are multiple models of this type of water flow sensor. These models vary in size and material. Depending on those two characteristics these sensors have different maximum flow rate range, operating temperature resistance, water pressure resistance, and durability.

For this project we compared seven different models of water flows sensor. Some of them have a plastic body, while others are made out of cooper. The prices for these sensors vary from \$6.0 to \$15.19.

Sensor Model	Working Voltage	Flow Rate Range	Operating Temperature	Liquid Temperature	Water Pressure	Body Material
YF-B1	5V – 15V	1 – 25 L/min	≤80°C	≤120°C	≤1.75MPa	Copper
YF-B2	5V – 15V	1 – 25 L/min	≤80°C	≤120°C	≤1.75MPa	Copper
YF-B3	5V – 15V	1 – 25 L/min	≤80°C	≤120°C	≤1.75MPa	Copper
YF-B7	5V – 15V	1 – 25 L/min	≤80°C	≤120°C	≤1.75MPa	Copper
M11*1.25	5V – 24V	0.3 – 6 L/min	≤80°C	≤120°C	≤0.8MPa	Plastic
G1&8	5V – 24V	0.3 – 6 L/min	≤80°C	≤120°C	≤0.8MPa	Plastic
G3&4	5V – 24V	0 – 60 L/min	≤80°C	≤120°C	≤2.0MPa	Plastic

Table 26 - Water Flow Sensor Models Comparison Table

The YF-B series models of copper sensors have a good flow rate range and water pressure. Since they are all made out of copper, they are highly resistant and are less likely to be damaged. These sensors also have a wide range of working voltage. One drawback for these models is that they are heavier than the plastic sensors. The weight may not seem much for one, but it adds up when many of these sensors are used.

The M11*1.25 and G1&8 model sensor has a smaller flow rate range as well as a smaller water pressure. They are considerably smaller than the previous models and lighter as well. Since they are made from plastic, they are less durable. These sensors have a wider working voltage range than the YF-B series.

The G3&4 model offers the biggest water flow rate and water pressure among the sensors we considered for this project. It also offers a greater working voltage range than the YF-B series. Since it's made out of plastic, it is less durable than the copper ones, but its size makes it sturdier than the M11*1.25 and G1&8.

Sensor Models	Advantages	Disadvantages
YF-B series	<ol style="list-style-type: none"> 1. Copper body make them more durable. 2. Good water flow rates. 3. Good water pressure. 	<ol style="list-style-type: none"> 1. Higher price. 2. Heavier. 3. Smaller working voltage rate
M11*1.125 and G1&2	<ol style="list-style-type: none"> 1. Cheaper models. 2. Higher working voltage rates. 	<ol style="list-style-type: none"> 1. Smaller water flow range. 2. Smaller water pressure. 3. Less durable.
G3&4	<ol style="list-style-type: none"> 1. Highest water flow range. 2. Highest water pressure. 3. Higher working voltage rates. 	<ol style="list-style-type: none"> 1. Highest price. 2. Less durable.

Table 27 - Water Flow Sensor Comparison Table

After evaluating the different models of water flow sensors, we decided to use the YF-B3 model. This model has the correct size for our system and works in the appropriate water flow and pressure ranges. Its material also makes it extremely durable, thus requiring less maintenance. The prices for this model are also average compared to the other models.



Figure 37 - YF-B3 Water Flow Sensor [23]

*Permission Requested

Turbidity Sensor

The main difference between the models lies on their different operating and storage temperature of their sensors. The TSD-10 sensor offers a balance range for its operating and storage temperature. It allows for higher maximum operating and storing temperatures than the TSW-10 model, and a slightly lower minimum storage temperature.

The TST-10 is resistant to storage in surprisingly low temperature; however, this is an extreme value in which there is almost zero chance that our system will be stored.

The TSW-10 model can operate in lower minimum temperatures than the rest of the turbidity sensor, but in contrast it has a lower maximum temperature for both storing and operating. Same as with the previous model it is highly unlikely that this system will need to operate in such low temperature. Furthermore, it is more likely that some cases will present themselves in which the sensor may be forced to operate in higher temperatures, making the lower maximum temperatures a disadvantage. This makes this sensor model the less practical for our system.

Lastly, the SEN0189 offers a balanced storage temperature range, but has higher minimum temperature for operating. However, this is not a detrimental factor for our particular system, since it doesn't require such low minimum operating temperature as the other sensors provide.

Taking into consideration that the minimum operating and storing temperatures required for our system aren't as low as the ones provided by these sensors, and that the maximum temperatures were similar, the deciding factor in the selection of the sensor became the operating current. The SEN0189 provides a slightly larger maximum operating current and works in an appropriate temperature range for its intended use.

Temperature Sensor

After deciding what type of temperature sensor, we would use, we started comparing the different available models from different manufacturers. For this type of temperature sensor there wasn't much variety in terms of performance or capacity. The main difference between each type of sensor came from the price and length of the temperature probe's cable.

After the different models offered, we narrowed our choices to three. The Adafruit waterproof digital temperature sensor, the ME temperature sensor, and the DFRobot water digital temperature sensor.

Sensor Model	Cord Length	Temperature Range	Price
Adafruit waterproof digital temperature sensor	25.59" (650.00mm)	-55°C to 125°C	\$9.95
ME temperature sensor	17.72" (450.00mm)	-55°C to 125°C	\$9.09
DFRobot water digital temperature sensor	37.4" (950.00mm)	-55°C to 125°C	\$7.90

Table 28 - Temperature Sensor Price comparison

As can be seen from table 28, all three temperature sensor probes offer the same temperature measurement range. This made our decision among them solely based on price and cord length. The length of the probes cord was important to us because it gives the device a more versatile use in our system. Although the intended use of the temperature probe is to measure the already filtered water temperature, by including a long enough cord with the probe it is possible for the user to measure the unfiltered water temperature as well. This allows the user to check that the water is inside the temperature range that the filtering system is capable of handling.

Among the three options, the ME temperature sensor has the shortest cord, and has a price similar to the Adafruit waterproof digital temperature sensor. For this reason, we decided not to use this sensor in our project.

From the remaining two sensor, the Adafruit waterproof digital temperature sensor offers a decently long cable but at the highest price. The DFRobot water digital temperature sensor on the other hand has the longest cable and is offered at the lowest price compared to the other two probes. This motivated our decision to use the DFRobot sensor in our project.



Figure 38 - DFRobot waterproof temperature sensor probe [24]

*Permission Requested

4. Standards and Design Constraints

Any projects would have to adhere to specific standards and design constraints. Standards are the minimum requirement any projects have to adhere to, and design constraints are boundaries a project needs to fall into. Constraints can go anywhere from time constraint to financial constraint all the way to voltage and current needed to supply the water filtration system device.

This section includes the following:

- Multiple constraints associated to this project.
- Among the various constraints, some of them might have detrimental effects on the end product.

4.1 Standards

Standards are rules that define, specify and control the development in the creation of a project. They are important as they can benefit to the users as well as the creators economically. The goal of having standards is to make sure that the product will be adequate and safe. In the following Table 2, we have gathered the standards that are very important to follow and that were made by the Institute of Electrical and Electronics Engineers Standards Association (IEEE).

4.1.1 Solar Panels Standards

In this section, we mentioned the different standard codes that apply to solar panels. It includes the following: The International Electrotechnical Commission (IEC), Underwriters Laboratories (UL), the Institute of Electrical and Electronics Engineers Standards Association (IEEE), and the International Standards

Organization (ISO). The main objectives of these standards are to make sure the final product is safe to use and satisfy the requirements set by those standards.

Standard Code	Description
IEC 61345	UV test for photovoltaic (PV) modules
UL 1741	A standard that informs about the use of different electrical equipment such as converters, charge controllers, and interconnection system for use in stand-alone (not grid-connected) or utility-interactive (grid-connected) power systems.
IEC 60904	Solar simulator performance requirements for all different types of solar panels available in the market.
IEEE 1547	A standard that provides a uniform standard for interconnection of distributed resources with electric power systems. It provides requirements relevant to the performance, operation, testing, safety considerations, and maintenance of the interconnection.
IEC61836	A standard that provides terms, definitions and symbols for solar photovoltaic energy systems.
IEC 60904-1	Measurements of PV current-voltage characteristics for photovoltaic devices.
IEEE 1562	A standard that gives information that guide for Array and Battery Sizing in Stand-Alone Photovoltaic Systems
IEC 60904	A standard that includes the following sections: requirements for reference solar devices, determination of the equivalent cell temperature (ECT) of photovoltaic (PV) devices by the open-circuit voltage method, solar simulator performance requirements
IEC61646	Thin-film terrestrial photovoltaic (PV) modules - Design qualification and type approval.
IEEE 1526	A standard that tests the performance of stand-alone photovoltaic systems.
ISO 9488	A standard formed by a technical committee at International Organization for Standardization that consists of basic vocabulary that is to be used when we discuss solar energy in a scientific manner
IEC 61853	A standard that includes the scope of the work in progress and also includes irradiance, temperature performance measurements, and power rating for PV module performance testing and energy rating

Table 29 - Standards for Solar Panels

4.1.2 Water Filters

Standard	Description
<p>NSF/ANSI Standard 44</p>	<p>Applicable to water softener systems designed for hardness reduction and health claims. Standard 44 establishes minimum requirements for the certification of residential cation exchange water softeners.</p>
<p>NSF/ANSI Standard 55</p>	<p>Applicable to systems utilizing ultraviolet (UV) light to provide disinfection. Standard 55 establishes minimum requirements for the certification of UV systems. The scope of Standard 55 includes material safety, structural integrity, product literature, and UV performance.</p>
<p>NSF/ANSI Standard 58</p>	<p>Applicable to systems employing reverse osmosis technology to address total dissolved solids (TDS) reduction and health claims. Standard 58 establishes minimum requirements for the certification of POU reverse osmosis systems.</p>
<p>NSF/ANSI Standard 62</p>	<p>Applicable to distillation systems designed for TDS reduction and health claims. Standard 62 establishes minimum requirements for the certification of POU and POE distillation systems.</p>

Table 30 - Water Filters Standards

4.1.3 Remote Connectivity

Standard	Description
IEEE 802.15.1	Task group one is based on Bluetooth technology. It defines physical layer (PHY) and Media Access Control (MAC) specification for wireless connectivity with fixed, portable and moving devices within or entering personal operating space.
IEEE 802.15.2	Task group two addresses the coexistence of wireless personal area networks (WPAN) with other wireless devices operating in unlicensed frequency bands such as wireless local area networks (WLAN).
IEEE 802.15.3	IEEE 802.15.3-2003 is a MAC and PHY standard for high-rate (11 to 55 Mbit/s) WPANs.
IEEE 802.15.4	This standard deals with low data rate but very long battery life (months or even years) and very low complexity.
IEEE 802.15.5	This standard provides the architectural framework enabling WPAN devices to promote interoperable, stable, and scalable wireless mesh networking.
IEEE 802.15.6	Task group approved a draft of a standard for Body Area Network (BAN) technologies.
IEEE P802.15.8	Wireless Medium Access Control (MAC) and Physical Layer (PHY) Specifications for Peer Aware Communications (PAC)

Table 31 - Wireless Connection Standards Table

4.1.4 International Software Testing Standards

The goal of International Software Testing Standard is a recognized combination of standards in software trial which come after any SDLC (Software Development Life Cycle) model in creating software. These are international rules that define, prepare, specify and control the development in the creation of a project. They are important as they can benefit to the users as well as the creators. The goal of having standards is to make sure that the product will be adequate and safe.

Standard	Description
ISO/IEC 333063	Provides information necessary for the implementation process as far as testing protocols, tools and techniques/procedures.
ISO/IEC 25000:2005	A standard that gives procedures regarding software quality requirements, also known as SQuaRE. It gives a lead to check them accordingly.
ISO/IEC/IEEE 29119-5	A standard that uses pre-defined words in order for testing. It is mostly correlated to specific tasks to achieve in a specific experiment in order to advocate, find and help write test cases.
ISO/IEC/IEEE 29119-2	A standard that gives the test requirements and try to characterize a generic model for software testing. It also can be utilized in any stage anywhere within the range of the software development life cycle. It is made of three sections that are mainly composed of detailed organizational, dynamic and board testing.
ISO/IEC/IEEE 29119-4	A standard that gathers all testing techniques for software design into one international standard.

Table 32 - International Software Testing Standards Table

4.1.5 Battery standards

Standard	Description
IEEE 485	Recommended practice for sizing Lead-acid Batteries for stationary applications
IEEE 1578	Recommended practice for stationary Battery Electrolyte spill containment and management.
IEEE 1187	Recommended practice for installation design and installation of valve-regulated Lead-Acid Batteries for stationary applications
IEEE 450	Recommended practice for the maintenance, testing, and replacement of vented Lead-Acid (VLA) batteries for stationary applications
IEEE 1188	Recommended practice for maintenance, testing, and replacement of Valve-Regulated Lead-Acid (VRLA) batteries for stationary applications
IEC 62133	Standard that test the build quality of the battery, starting with the stress the mold casing can take, then an external short circuit, followed by a free fall, and finally an overcharging
UL 2054	This standard includes 18 tests in order to makes sure that batteries meet U.S. device standards applicable to household items. This increase the safety of each battery pack and lowers the risk of bringing it into public and private spaces
BS EN 619602-2	This standard applies to portable applications. our project is designed to be moved and stored in different environments it is crucial to understand how they work portably

Table 33 - Battery standards

4.2 Constraints

4.2.1 Battery Constraints

Batteries either small or large can cause serious damage if they are misused or due to malfunction. A great example can be the Samsung phones battery issues. In addition to the safety issues, those phones were banned from a lot of places, and it costed Samsung billions of dollars to fix the issue and recover from it. Due to these reasons there are strict standards set by the electric and electronic

industries. In our project, we'll follow all the safety standards and recommendations mentioned by the manufacturer for proper and optimal usage.

Also, in our project we'll implement a charge controlling circuit to maintain the health of the battery and to protect from overcharging. And we'll have a firm mount to make sure the battery is in place and doesn't wobble.

4.2.2 Funding constraint

We set up a specific budget for our senior design project, but we soon realized that it needed more components that we have originally planned. Some of us do not get financial aid and are paying tuitions out of pocket so we decided that some of us will financially contribute more to the project than others. The cost of our project limited our ability as to decide which parts we needed for the project without spending too much on one component and not having enough funds to buy the tools necessary to complete our water filtration. We decided to increase our budget so we could have many options to choose from. Our original budget was close to three hundred dollars, but we decided to increase to our budget and keep it under five hundred dollars. So far, the estimated total of our project is around four hundred and eight dollars. Again, this is a brief estimation. We will have to combine and test all the materials and equipment and like in any projects, issues may or may not happen and it may also interfere with our water filtration system.

4.2.3 Time constraint

We have had multiple time issues. One of them was mainly due to our conflict schedules. When some of us were working, other had school, and vice versa. Also, another time constraint was actually to get the parts. When we had the time and availability to meet up, we went to different facilities to look for specific parts that were required for our water filtration systems. However, when we got there, we encounter the most common issue that most senior project had to face: the specific product we were looking for was unfortunately out of stock. The companies advised us to look for the part online and to order it online. Once we found the part online and order it, some of them arrived broken or when we tried to connect it to a specific device, no power was generated. We wasted time to return the part and ordering a new one. And since our project had assignments to be done and completed at a certain date and time, we had to make sure we got everything done ahead of time just in case one of these circumstances happen.

4.2.4 Size constraint

One of the main characteristics and what stands out the most in our senior design project compare to other projects is that ours is mainly designed to be compact and portable. One of our main concerns was the solar panels. Solar panels are known as being very large in size and heavy. The average for the typical panels is 5.4 feet by 3.25 feet. Again, it is an approximation and it may differ, depending on the various manufacturers. Clearly, the dimensions were a tremendous issue in

our project. Since our water filtration is portable, we had to find a solution in order to make it convenient, so it does not take up too much space. We came up with a solution and decided to use thin film cell solar panels. They are different in our known solar panels used in residential houses. They are flexible and easy to carry around. Our water filtration system consists of three solar panels and an approximation for the size of one is 20.5 inches by 14.2 inch with a thickness close to 1.2 inch. We also have a case that will have the three solar panels that will be attached on top and can be easily removed using magnets. Our case had to be not too small and not fit all the components needed for the project and it could not be too large and take too much space. The size of our case is 14.5 by 12 by 17.9 inches. It was the perfect fit under our solar panels. All the parts had to be carefully chosen and we had to make sure all the parts fit.

4.2.5 Components Availability Constraint

Another important issue that we faced was the components availability constraints. Not only it was difficult for us to find all the components needed for our water filtration system, but it was even more difficult to receive all the parts needed in a timely manner. With a time frame that was limited, we had to make sure all the components arrived at a certain deadline because we not only had to test every component separately, but we had to make sure they all worked together but combining the hardware and software part of our portable water filtration system.

Sometimes, one component was needed in order to make sure of the sensors worked. However, as our time frame is limited, some of our components arrived very late, sometimes weeks after. It was very difficult to have all the parts together when we needed them. Also, other components were sold out so we had to call and check with the company and most of us did specify that it would be better to call them in a few weeks and double check with them if they go the part or not. They also mention that it could take at least few months to arrive since it was mainly shipped from another country which directly affected the timeline, we had set up for our water filtration system. We tried to find alternatives and get a part that similar to what we needed but unfortunately it did not work, and we had to wait few weeks to get the part that was essential in our portable water filtration system.

4.2.6 Water Constraint

Since power and electricity will be generated, it is more than crucial for our water filtration system to be waterproof and that no little or major leakage happen. With the options between monocrystalline, polycrystalline, and thin cells solar panels, we had to make sure ours was weather protectant. All of the solar panels listed do have water protection; however, the thin cells solar panels fitted our water filtration system the most. When it was time for us to look at the different cases available on the market, we had to make sure no water could go inside the entire system and damaged it. It was extremely difficult for us to not only find the right size but to also find one that is waterproof as well. We also had to make sure we could draw

a rectangular hole on the side of the case so we could place an LCD display. It would then be easy for the user to read on the LCD display the information the water filtration system will show such as: the temperature, the turbidity, the water level as well as when it is time to change one of the filters. We also added in our project a manual handle just in case if the water filtration system happens to shut down. We added the handle on the side of the case, on the other side of the LCD display. We had to be extremely careful and cautious and make sure no water would come inside case and that could jeopardize the entire water filtration system.

4.2.7 Social Constraint

The main goal of our project is providing clean and safe water for anybody that is in need and to save a life, a day at a time. The design was extremely important because again, its targeted adults and young adults. We know that most people who are in need of clean and safe water are people living in Third World countries such as Africa and Asia. We came to the realization that there were a language barrier and most people do not speak or read English. That is why we decided and knew it was the best solution to make sure our water filtration system was easy to use, with minimum use of complicated words.

We tried the best we could to create an application that would be easier for them to use and understand. We decided to use words that are easy to understand such as “On, Off, Change, Replace”, and the word “Water”. We knew that the more complex we tried to make the water filtration system, the more people will not be willing to learn and use it and will go back to their traditional ways of getting clean and safe water.

The main components that will help them use the device will be an ON/OFF switch, to turn on and off the water filtration system, an LCD display that will display of the main information such as when it is time to change one of the filters or when it is time to change the battery, and last but not least, a manual handle. The manual handle will give them the opportunity to use the device if in case one day, the system shuts down or the weather conditions do not provide sufficient solar energy, they will be able to use the manual handle and generate power that will turn into electricity for few days and that will give them the ability to have safe and clean water for few days. The easier we made the water filtration system; the more people will adhere to it and it will improve their quality of life tremendously: not only every day but their health will improve with the consumption of safe and clean water.

4.2.8 Networking Constraint

Twenty years ago, owning an electrical device such as a cell phone was very expensive and something that not a lot of people could afford. Today with the sky rocking evolution in technology, in every single household around the entire world, at least one member of the family owns a cell phone with Wi-Fi. We decided to

include an application that will provide an easy to read information regarding the water filtration system such as pH and when it is time to change one of the filters. We were debating as to include an application or not in our senior design project but when I traveled outside of the country in a remoted area where it was difficult for people to have access to clean and healthy water, I noticed people having cell phones in their hands. We thought it would be a great idea to include this and give them the ability to find information regarding the water filtration system no matter where they are, one mile away or 100 miles away from the water filtration system.

4.2.9 Portability Constraint

One of our main goals for our water filtration system was to be portable. There are different types of solar panels, monocrystalline, polycrystalline, and thin film cells solar panels. Most solar panels are known to be large, take a lot of space and are mostly extremely heavy. If we decided to have the project done with regular panels such as the monocrystalline and polycrystalline, it would have been very bulky and not portable. However, the thin film cells solar panels are not only flexible, but they are also lightweight. The user will have the advantage to carry it around wherever water is found, since it is portable and lightweight.

Our entire water filtration system is composed of three solar, each of them are attached to our case via magnets. Four magnets will be attached to each corner of one solar panel. These are easily removable so it will give the user the option to remove or attached the solar panels with minimum effort. The weight for our project was as follow: our flexible solar panels weight is less than five pounds which is significantly lighter than other types of solar panels that weight about twenty to twenty-five pounds each.

4.2.10 Software Constraint

During the development of our software, we had to make sure that all the components needed were achieved during a specific amount of time. During the API (Application Program Interface), we all divided our set of tasks among each other and some of us took the initiative and decided to work on additional functions in our application. Some of us had previous experience on software development and agreed to have additional tasks. We had to make sure the interface worked perfectly. However, we ran into some issues: we wanted to expand to our software development but unfortunately due to time constraint, we did not have the opportunity to do so. Some of the tasks required one team member to finish it in order for the other team member to use the task completed and added it in order to make it function properly. It took longer than expected for some team members to complete their tasks and we fell behind schedule.

4.2.11 Networking Constraint

The main objective for our water filtration system is to help people who are in need and that cannot have access to clean and safe water. We created an application that will help them monitor the water level, the turbidity of the water, the pH and also the application will alert them when it is time to change one of the filters. However, most people that do not have access to clean and safe water are mostly located in remote areas where wireless signals tend to be very weak or non-existent.

Most people in need of clean and safe water live in areas where the internet connection is extremely weak or there is no connection at all. We can conclude that the weak signal is due to the internet connection or to a router that does not have the minimal signal strength needed or because the location does not have any connections at all.

With no connection whatsoever to the application we created, it will be difficult for the user to know the status of the water filtration system when it comes to any modifications or change that has to be made. The networking constraint was an important part of our project. It did take us few weeks just to design the application and another few weeks to decide what to include and what not to include in our application. We wanted our user to not only be able to get clean and safe water but we also wanted them to have the ability to use the apparatus on their own, to customize it themselves and to be able to share that knowledge so not only few people would get the opportunity to get healthy, but they will also be able to save lives.

5. Hardware Design

5.1 Hardware Design Flow Overview

This section provides a more detailed explanation of the interactions of the different hardware components used in the project and found in the flow diagram of section 2.5.

5.1.1 Water Pump

The water pump will be controlled by the microcontroller and the relay. Even though its optimal voltage input is 12 volts, the selected water pump for this project to be able to function at a desirable capacity with an input voltage of 6 volts.

5.1.2 Microcontroller

The microcontroller is the most essential part of the device. It is in charge of controlling the multiple sensors that will provide important data of the water condition and the device itself, and the microcontroller also regulates the water

pump and the Bluetooth module. It gets the power necessary to operate from the battery and voltage regulator.

5.1.3 Sensors

The different sensor used in our device will be all controlled by the microcontroller and will show the information gathered on a local display in the device, as well as sending it through the Bluetooth module to mobile devices.

5.1.4 Bluetooth Module

The Bluetooth module will receive the information of the sensor through the microcontroller and communicate the information to mobile devices that are using the application developed for the project.

5.2 Schematic Design

This section contains all the information related to the different schematic designs created for the proper functioning of the hardware devices used in the water filtration system.

5.2.1 Microcontroller Schematic

The microcontroller as stated several times before is the one in charge of collecting, processing, and manipulating all the data received from the sensors, as well as controlling the Bluetooth module and the water pump. The input voltage of the microcontroller will be controlled by a voltage regulator and the microcontroller will only be on when an external switch located in the water filtration system is activated.

Depicted in Figure 39 is the mapping of the pin connections for our system. The sensors are connected to five analog input pins and the Bluetooth module is connected to the UART pins both RXD and TXD pins. The Bluetooth module schematic and the process of interaction between the module and the microcontroller will be explained in section 5.2.3.

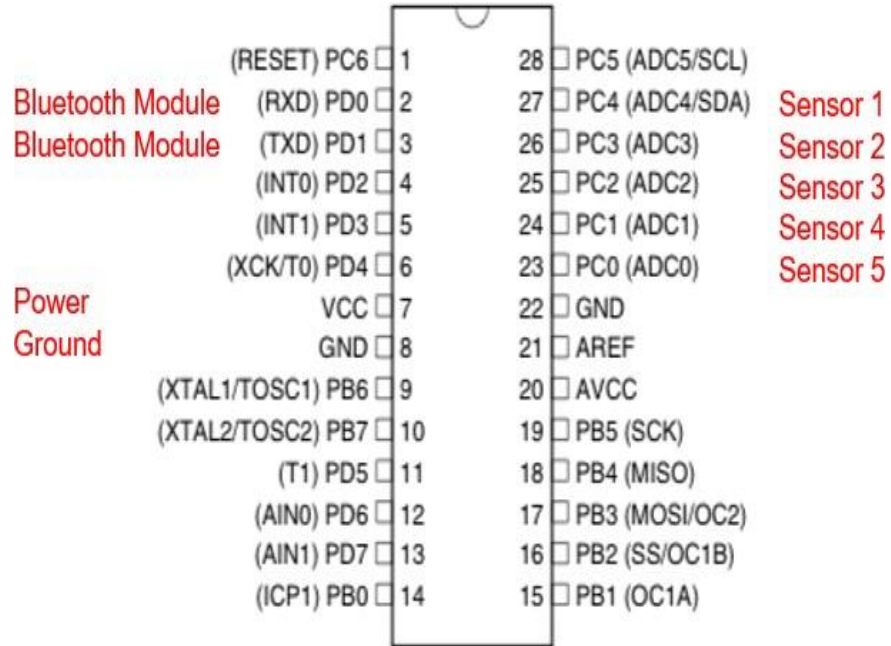

Figure 39 - Pin Mapping

The schematic shown in Figure 40 represent the connection of the LCD display to the Atmega328 of our project. This schematic was done with the goal of using the fewer amounts of pins possible for the display since our device uses a considerable number of sensors that need to be mapped to analog inputs pins and the number of pins available are limited.

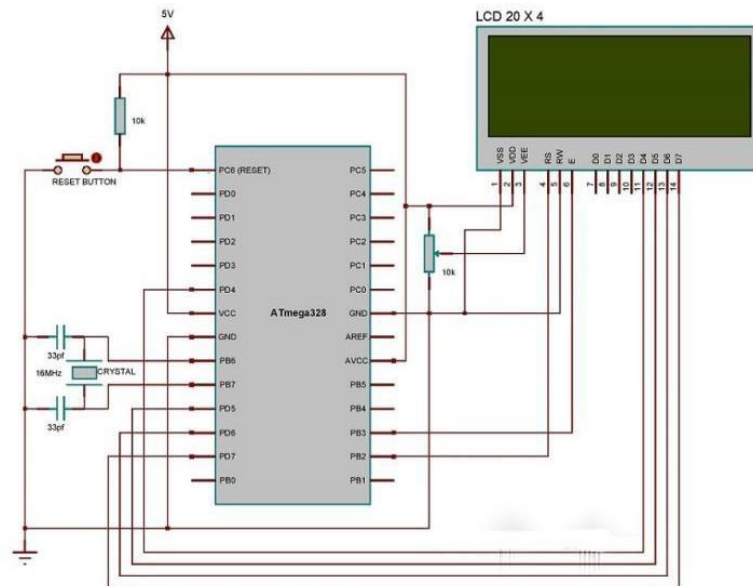

Figure 40 - LCD Display Mapping

5.2.2 Microcontroller Program

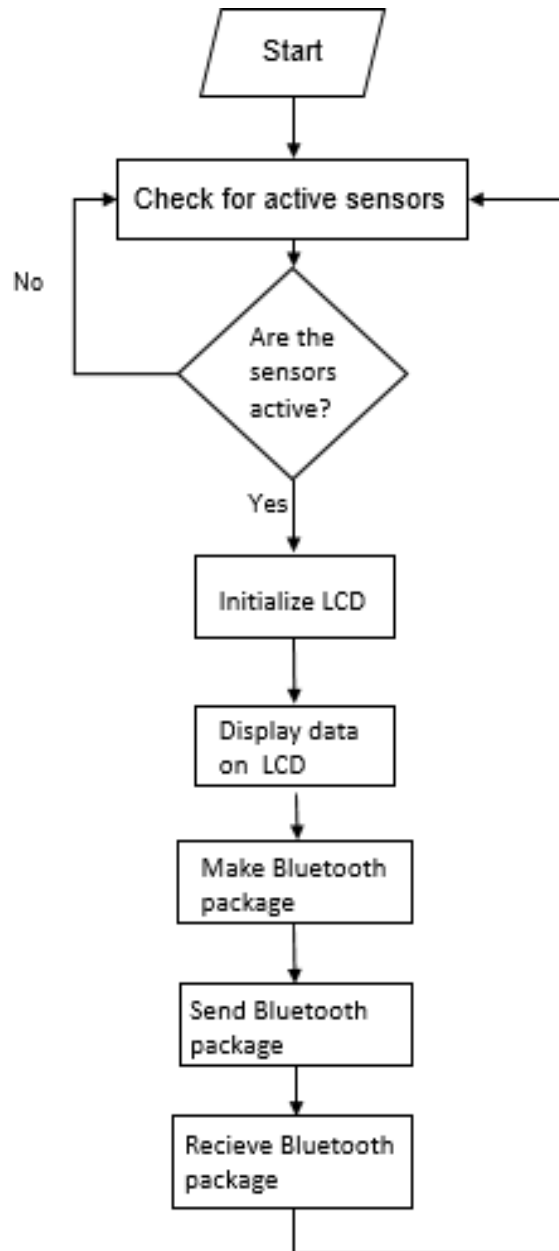

Figure 41 - Microcontroller Program Flowchart

5.2.3 Bluetooth Module Schematic

The microcontroller needs to read all the different sensors data. The sensors present in our project are a temperature sensor, a water flow sensor, a turbidity

sensor, a leak sensor, and pH sensor. The data from these sensors are packaged into a response Bluetooth packet and sent through the Bluetooth module to a mobile device. As explained previously in section 5.2.1 the module uses RX and TX pins to communicate with the microcontroller and pass data between the two. Both the Rx and Tx pins are working as a UART for the microcontroller.

The microcontroller schematic that shows the connections of the Bluetooth module to the microcontroller is depicted in Figure 37. More information about the Bluetooth module being used in this project can be found in section.

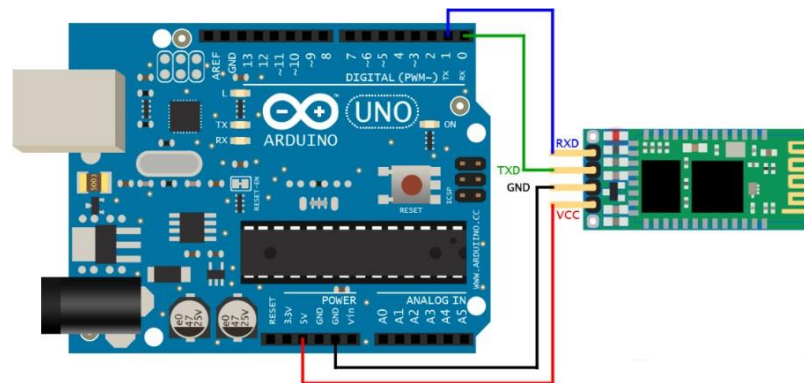

Figure 42 - Bluetooth Module Mapping [25]

*Permission Requested

5.2.4 Water Tank and Case Design

The design of both the case and the water tank of our filtration system is probably the most important aspect of the device for the user of the product. The design of both of these objects determined not only the portability and convenience of the product, but also the safety of its use for the consumer. Since the device works with water and electricity, any type of malfunction must be avoided. If the system were to fail the well-being of the user could be compromised.

IP rating	Protected against
0	No protection
1	Vertically falling water drops
2	Direct sprays up to 15 degrees from the vertical
3	Direct sprays up to 60 degrees from vertical
4	Sprays from all directions (limited ingress permitted)
5	Low-pressure jets of water from all directions
6	Strong jets of water (limited ingress permitted)
7	Effects of temporary immersion between 15cm and 1m for 30 minutes
8	Long periods of immersion under pressure; duration determined by manufacturer

Table 34 - IP Rating

The table 34 show the ingress protection rating which is a level of protection against intrusion of water published by the International Electrotechnical Commission (IEC). Base on this rating our group decided that both the case and the water tank should have an IP rating of at least 5, which refers to protection against Low-pressure jets from all directions. This level of protection should be enough to protect the device against rain, this is the only situation in which the device could be exposed to water. For this reason, we decided that the best option for the case would be to use a waterproof carrying case that will maintain all of the electronics of the filtration system protected without affecting considerably the weight of the product.

Even when the device is protected from external sources of water it could be compromise if the water flowing through the filtration system were to leak inside the device. To protect the devices internally we choose to use molded plastic to incase the internal electronics.

The water tank on the other hand will be made of clear plastic to make it as light and portable as possible. The clear aspect of it will allow the user to keep track of the amount of water being filtered making it as convenient as possible. The sensors present in the device would not need any type of protection since all of them are waterproof and very resistant.

Another important aspect of the case design is the position of the solar panels attached to it. The solar panels will be located on top of the case, they will be

removable and bendable so they can be stored separate from the rest of the device since the panels are very fragile and need to be handled carefully. By placing the panels on top of the case we believe that enough amount of sunlight would be perceived so the device can function properly and the battery can be recharged.

5.2.5 Filters Connection Design

The filters piping is a crucial part of this project, if done incorrectly it could affect the overall design of the project as well as the condition of the filtered water. As explained in section 3.2.6 our project will use four different types of filters: a sediment filter which removes debris, dust and small solids, a pre-carbon filter that gets rid of toxic components found, an ultrafiltration filter that takes care of macromolecules, and a UV filter which eliminates viruses and disease-causing bacteria.

All filters need to be connected properly for them to function efficiently. If for example the UV filter is connected first it would cause a malfunction since the unfiltered water could contain solid objects that the filter is unable to process. For this reason after some research the group decided that the best option is to place the sediment filter at the beginning of the filtration system since this filter can hold small solids that can be present in the water, followed by the pre-carbon filter that removes big particles in the water, after it the ultrafiltration filter will be placed to get rid of any macromolecules, and at the end the UV filter takes care of the dangerous bacteria or viruses that could still be present in the water.

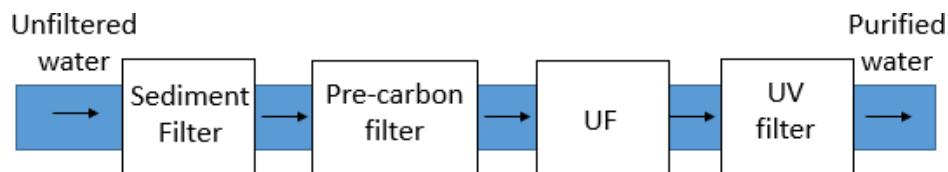

Figure 43 - Filters Order

Another important aspect of the filters piping is that the space it could potentially be too much for a medium case which is the size we are aiming for. If the piping is not done properly the portability of the device would be compromised significantly. To optimize as much as we can the space of the case, we decided to use C plastic claps to attach two of the filters at the bottom of the case and X plastic claps to overlap the remaining filter on top of the other two filters. For the actual connection of the filters we decided to use plastic elbows, I-connectors, and thin pipes to make the flow of water as good as possible without any leaks.

The water obtained with this design should meet all the basic requirements and satisfy the necessities of the users. The compact size will allow the device to be more portable and the connections made with the different objects explained previously will prevent any risk of leak.

6. Software Design

This section will be divided into multiple parts: for the first part, we will talk about the approach and method we used to develop the software. For the second part of the software design, we will focus on the tools we used for our water filtration system. For the third part of this section, we will focus on the software that will control our microcontroller. All the different sensors on the printed circuit board that are embedded in our water filtration system will send information to the code and act based upon it. For the last part of the software design, we will talk about how the software will work on the user's phone. With the creation of the software, the user will have access to different settings and will also be able to customize certain functions to the application.

6.1 Methodologies

Agile is considered a type of project management process and is widely used today in software development. Most people called it a waterfall model, meaning that we use a methodology to create an application in a more organized way. The first step into the waterfall model is to gather the requirements we need in order to create the software that we want. Then, during the implementation, that is when we will have some coding that will be executed. Next, we will have verification and last but not least maintenance.

In other words, Agile is a chain of rapid development and deployment meaning that the first section of the software is always the planning part then we design and develop the application. After that, we test, we deploy and last but not least we review it before we actually launch everything into production. Another aspect of Agile is instead of working a large portion of application, we work in iterations meaning we have a specific set of tasks that has to be completed in order of priorities so we exactly know what we are supposed to be working on. We want to make sure that our final project meets and satisfies all the requirements that were assigned to each team member at the beginning of the project.

Agile has different values: the first value is people over processes and tools, working software over comprehensive documentation, customer collaboration over rigid contracts and last but not least, responding to change rather than following a plan. So Agile is really feedback dependent meaning just because our plan was made does not mean that we cannot make any changes to it.

The most important and main advantages of Agile are the following: persistence software delivery increased, increased stakeholder satisfaction, inspect and adapt,

being able to welcome changes at any stages of the software application process, design is important and daily interactions with team members as well. Agile gave us the foundation to make better decisions which result in the creation of a more efficient software. By using Agile, we have uncovered better ways of developing the software by doing it and helping our other team members to do it if they ran into any difficulties or issues. The values that made us choose Agile are the following: individuals and interactions instead of processes and tools, knowing what the user wants and needs, and being able to respond to change instead of following a plan.

Our first priority in the development of the software was to make sure the user will easily use the application without any difficulties and it will have access to different settings so it will be easier for the user to customize the application at its own convenience. Also, part of developing the software meant that we had to set up meetings frequently, usually every few times every week, in order to make changes if needed.

We valued every team member and everyone was assigned a task to complete. When it was time for us to make an important decision for the creation of the software, we made sure that each team member was heard and that everyone gave us their point of view. Even though few team members were more involved in the development of the software, we respect every team member where no one is left behind when it comes to make an important decision.

We mainly chose Agile because it made it easy for the whole team to work in iterations meaning we each had a specific set of tasks that had to be completed in a certain amount of time. Each of our tasks was classified by order of priorities so we exactly knew what we were supposed to be working on. By doing so, we made the whole project easier to develop by making sure every small task and step of the software worked properly otherwise we might have to go through thousand lines of code trying to find the issue. This methodology worked great for us because it made sure we accomplished the small step first before combining them and move on to the next level of software development.

6.2 Tools Used for Development

Arduino is one of the easiest tools for controlling any electronic devices. For inputs, it controls sensors such as temperature sensors, light sensors, humidity sensors, are the ones we used for our water filtration system.

All these sensors are read by an Arduino board. As far as outputs, it includes our PCB (Print Circuit Board), LCD (Liquid Crystal Display) display, LED indicator lights. So, Arduino was used to read inputs and controlled outputs. Arduino is made of three components: the physical component, which is the board called Uno, which has a microcontroller on it, the software IDE that we downloaded it and used it to program our Arduino board. The third component is the Arduino code: the code

that we wrote inside the Arduino IDE gets loaded onto the microcontroller that is on the Arduino board. The Arduino code we wrote is called a sketch. To write the lines of code, we used mainly C programming languages.

What made us choose Arduino is the ease of use of the microcontroller. Most of the microcontrollers have a user manual that is close to three hundred pages long. However, Arduino made it extremely easy: we connected to Arduino with a USB cable, then we can connect any electrical components is easy with the use of headers, by connecting them to the holes. The Arduino board also has an external power jack so when it is not connected to the computer, it can still be powered by a battery pack so that it is the ease of the hardware part.

The Arduino IDE is also designed for ease of use: there are a lot of integrated development environments, but the Arduino IDE is built with simplicity in mind. To upload the code that we wrote, we just had to click a button and it automatically uploads it. Finally, the Arduino code itself has functions specifically including reading inputs and controlling outputs. If we were to directly program our microcontroller without using Arduino, we would find ourselves constantly referencing the user manual for highly specific information we need for a particular sensor or for controlling something specific.

The Arduino language has significantly reduced that complexity by creating simple programming functions for us to use. In addition, there are many Arduino code libraries that we installed and used. These libraries simplified the use of all different types of components from interacting with different sensors to controlling different outputs. Arduino is also open source hardware, meaning other companies make Arduino boards compatible and can also be programmed in the Arduino IDE.

There were many different boards from Arduino, but we decided to choose the Arduino Uno Rev3 because most of the add-ons for Arduino called shields are built to work with the Arduino UNO. On top of that, the UNO has twenty separate input and output channels called pins, and out of all of those channels, some were used to read digital on-off type inputs.

We chose the software Arduino because there is such an incredible amount of infrastructure out there almost anything that we wanted to accomplish was easy to achieve because there were so many available resources and infrastructures regarding the use of Arduino. It only takes few minutes to install some software called the palette on which we created our platform. The whole Arduino system is made of IDEs, which are called Integrated Development Environment which helps in the programming, as well as a physical board, makes the whole Arduino system.

The use of a breadboard was really useful when prototyping. What makes Arduino so easy to use is they created a software that works on Windows, Mac and Linux, which makes uploading our code as simple as connecting a USB cable or a DC

power jack and clicking a button. Arduino also created a programming language that lets us configure all of the Arduino hardware products in the same way.

Most of the work that we did with Arduino was in the software. Once installed, every Arduino program has two main areas called the “void setup” and the “void loop”. In the void setup we set our pins and in the void loop, the tasks we need to do again and again were set in the void loop. The setup area is where we configured our Arduino to do certain tasks for the duration of a specific program we had: for example, we had information on which pins are inputs, which one had outputs but in this case, we are telling it to send serial data to our computer at 9600 bits per second, which is a standard rate for these type of situations. Arduino has an integrated circuit that does some computation and was extremely easy to use so for some of us without any prior electronics or programming knowledge could really get started relatively simply.

The Arduino company did it in twofold. First, as far as the hardware goes, they made it easily accessible so the Arduino board itself is a printed circuit board which includes the integrated circuit that some of us used and on the outside they have pin headers which allowed us to connect to the integrated circuit and they set it up in such a way where we could easily connect to our computer with a USB cable. On the software side, they have a software programming environment that was very easy for some of us who did not have prior programming experience. It was easy for us to program our different sensors and made sure that the pH and turbidity sensors would work accordingly and displayed the right information from the board to the LCD display of our water filtration system.

Not only the Arduino was easy for us to use, but the cost of it was budget friendly, under thirty dollars for an Arduino board. Also, to program the Arduino, it was completely open source but the hardware itself, the actual circuit board that the actual Arduino is made of was also open source and we were able to download the design files if we wanted.

6.3 Microcontroller Software

The software that will run in the microcontroller has multiple functions that help the user during the utilization of our system. The first function of the software is to read and analyze the data gathered by each of the sensors employed in the system. The sensors used in our project are intended to detect the status of the filtered water as well as the status of the system itself. The data from the pH and turbidity sensor is analyzed by the software to determine if the filtered water is safe from consumption. The water flow, temperature, and leak sensors data are analyzed to determine if there is a problem in the system. The water flow and temperature sensors are also used to verify if the system is being operated in the range required for the filters correct functionality. The data from some of the sensors is analog, so the microcontroller software also converts this data from analog to digital so it can be properly analyzed. To make sure that the readings are accurate the software

collects multiple samples from each sensor. Each sample is collected after a small delay from the previous one. The average of these samples is what is then used by the software for its calculations.

The software then has the function of sending the pH, turbidity and water flow data to the LCD display or alerting the user in case something is not working properly or the data is outside a certain range. If everything in the system is working correctly and the filtered water is safe for consumption, then software will show in the display the current values for pH and turbidity of the filtered water, as well as the water flow data from the sensors. This allows users to know there are no problems and that they can drink the resulting water. However, if the pH or turbidity is outside a safe range, the software will show a message on LCD display to alert the user. In this case the users are informed that the filters may need to be replaced or that the system was unable to make the water safe for drinking. If the water flow goes down the software will show a message informing the user that the unfiltered water in the container might be running out, or that the power from the power source to the water pump is decreasing. If the water flow or temperature goes above or below a determined range, the software displays a message alerting the user to turn the system off to avoid damage to the filters or water pump. If the leak sensor detects a leakage, the software will display an alert in the LCD display as well as the values from each water flow sensor. The values of the water flows sensors are displayed to help the user determine where the leak is originating. Lastly, the microcontroller software will also display an alert if it stops receiving data from one of the sensors.

Finally, the microcontroller software has the function of storing the collected data and sending it through the Bluetooth transmitter whenever a device is connected. The data read from the sensors during the use of the system is stored into a microSD card connected to the microcontroller through an SD card module. The data stored into the microSD card is then sent to the smartphone app of a device that connects to the microcontroller using the Bluetooth transmitter.

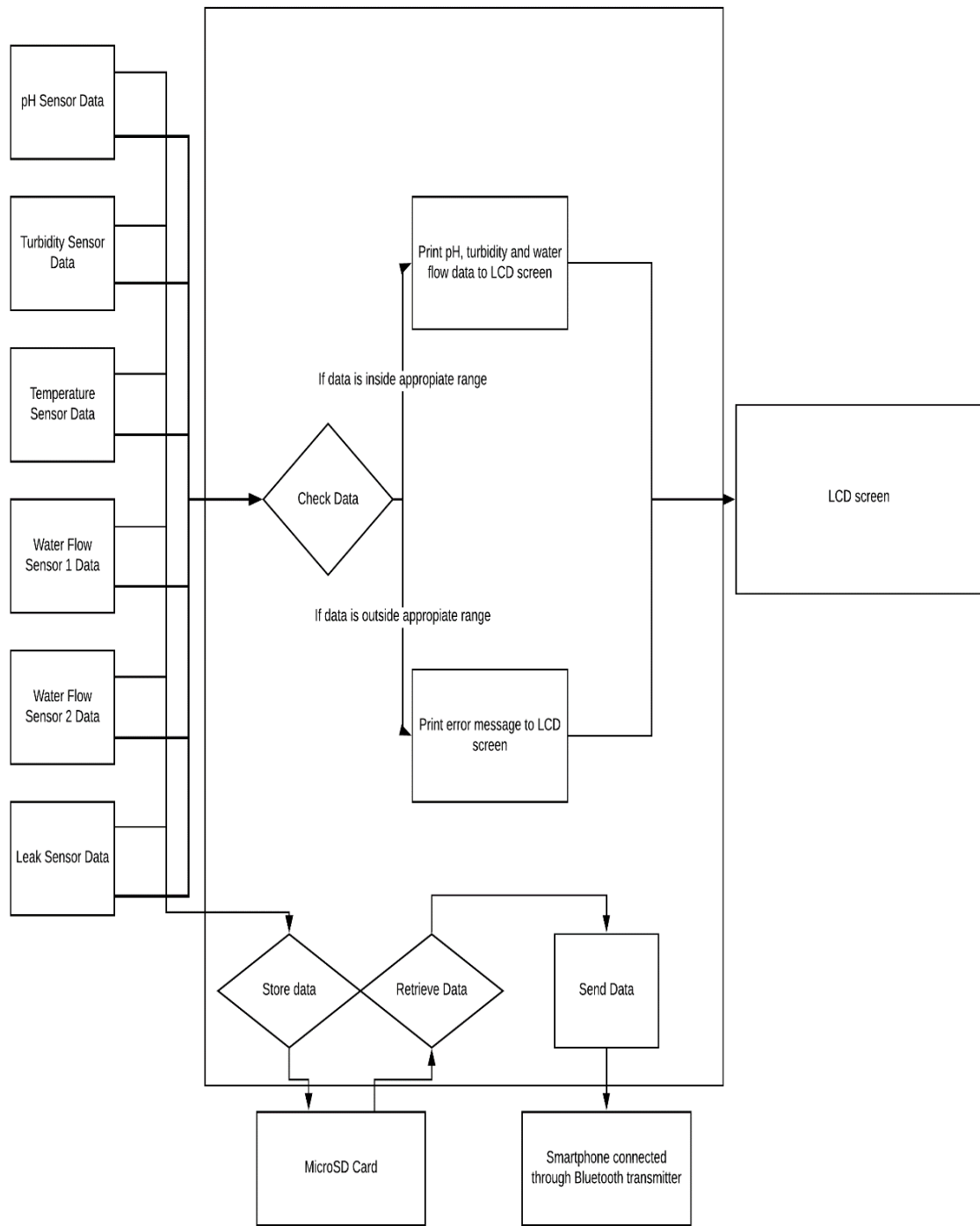

Figure 44 - Microcontroller Software Diagram

6.4 Smartphone Application Software

For the platform of choice in developing our smartphone application we decided to go with Android. There were multiple factors that influenced this decision. The first factor is that Google's Android Operating System is the most used smartphone operating systems in the world. Android currently has over 2.5 billion active users, which gives it the largest installed base among operating systems. Using Android for our smartphone application gave us the opportunity to allow a larger amount of people to use our application.

Another factor in our decision to use Android Operating System is that as the most used mobile operating system, it has a large variety of devices available at low prices that employ it as their operating system. This was important for us since we needed to take into consideration that our Water Filtration System intended users are people in developing nations. The fact that it is possible to acquire smartphone at really low prices that run on Android makes it more likely that our users will have access to a device capable of running our application.

We also decided to use the Android Operating System as opposed to Apple's IOS because different for IOS it is possible to easily develop applications for Android across multiple platforms, such as Linux, Windows and even Mac OS. This is in contrast to IOS whose development environment is limited to Mac OS devices.

All these factors, together with the fact that our group members had more experience with the development of Android applications, motivated our decision to use the Android Operating System and the official Integrated Development Environment for Android application development, Android Studios.

Design and Functionality

The main purpose of our smartphone application is to provide an analysis of the long-term data provided by each of the sensors. As the water filtration system is in use, the data obtained by each sensor is stored into a MicroSD card connected to the microcontroller unit. By analyzing the data stored into this card, it is possible to run diagnostics to the device's operation. The more the device is used the more data is gathered in the microSD card that can later be analyzed by the application, in order to make a better diagnostic of how the system has been operating over time.

With the analysis done by the application it is possible to determine if the filters need to be changed. The application will analyze the data of the water flow provided by the pump and the water flow that comes out of the filters and calculate the average difference between the two. The average water flow difference can then be used as a reference to determine whether over time this difference has increased. If the difference has gone above a certain value the app will determine that the filters need to be replaced soon. In a similar way the application will also

analyze the pH and turbidity of the filtered water. If the pH or turbidity of the filtered water has increased or decreased outside the acceptable values, it will determine that the filters need to be replaced.

By analyzing the data provided by the sensors over a long period of time the application can also make estimations regarding the time the filters can be kept in operation before switching them out.

After the first time the application determined the filters needed replacement, it will analyze how much water was filtered and how long it took for the water flow, pH or turbidity readings to go outside the appropriate range. This information will allow the application to make an estimation on how long the filters will work correctly. This estimation will become more accurate the more the system is used.

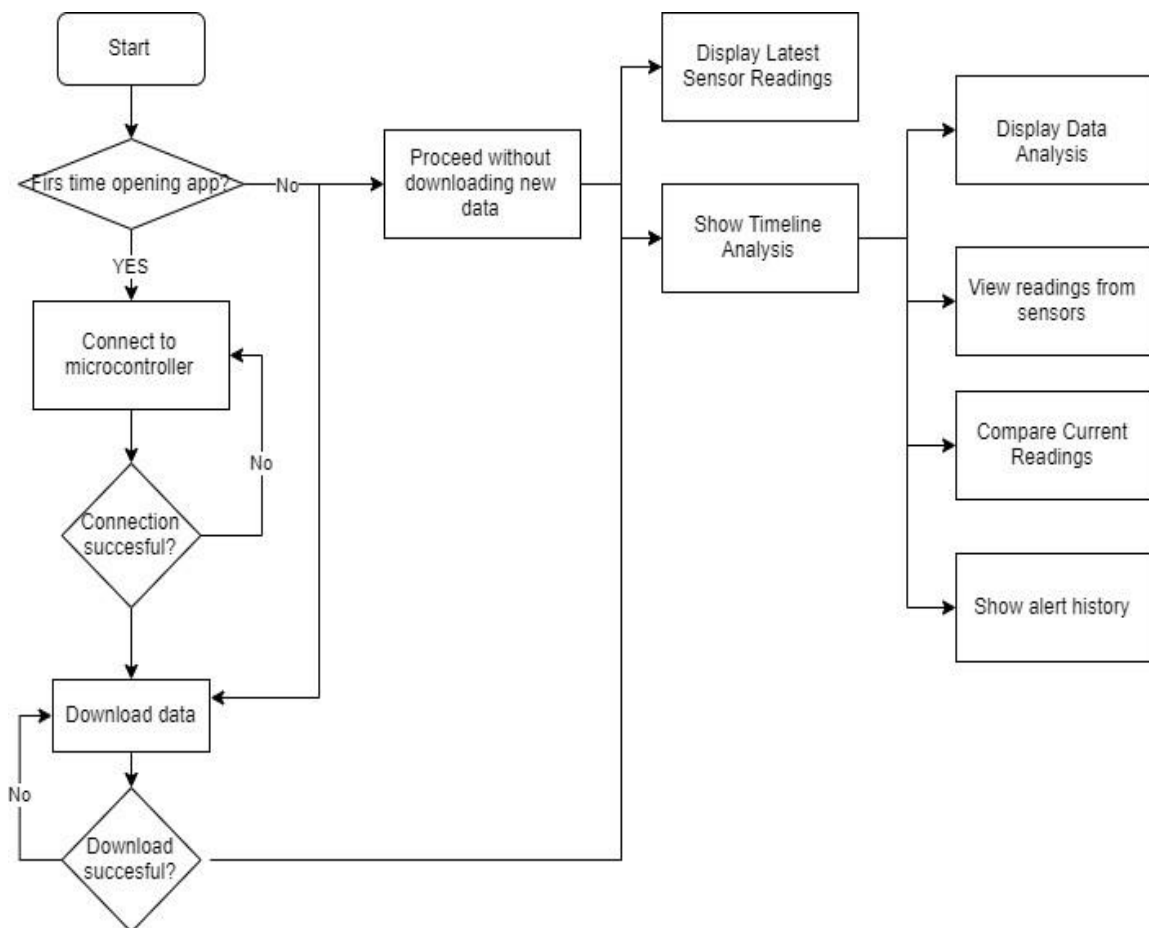

Figure 45 - Application UI Flow Diagram

The user interface of the application will be kept simple and intuitive. When the user opens the application for the first time, the user will be asked if he is within range of the water filtration system's Bluetooth transmitter and whether the device is on. If the user presses "Yes" the application will attempt to connect to the device. If the connection failed a message will tell the user to try again, if the connection was successful the application will start downloading the data stored in the microSD card by the microcontroller unit.

After the application has downloaded the data from the microcontroller at least once, when the application is opened the user will be given two options. The first option is to proceed using the data already stored in the application without connecting to the system. This would allow the user to review the data even without the water filtration device nearby or when it is turned off. The second option is to connect to the device to download the most recent data. This process will be similar to the one described before.

When the application has downloaded the data from the microcontroller unit it will then display the last readings received from each sensor and a button below that says, "Show Timeline Analysis". When the user presses this button, the application will display the amount of time the system has been turned on, the amount of water that has been filtered, the last time the filters were replaced, how long before the filters need replacement, and an option to view a detailed analysis from the system. If the user selects the option to view a detailed analysis from the system, the application will present several different new options: "View readings from sensors", "Compare current readings", "Show alert history".

The first option will allow the user to view the readings from each sensor over time. This will allow the user to see graphs depicting the values returned by each sensor over time.

The next option will let the user compare the normal values from each sensor to the current values returned by them, and to see the range in which these readings need to be.

For the next option the user will be shown all the alerts generated by the microcontroller from newest to oldest. This will allow the user to see when any of the sensors readings went outside the allowed range, when the system detected a leak or when the system has been operated outside the allowed conditions.

7. Testing and Demonstration Plan

In order for our water filtration to work properly, not only do we need to select the right components, but we also need to test all the components to make sure our project is working properly.

The section covers the following:

- The different phases of the hardware to make sure all the components work properly.
- The interface, we had to make sure that there no issues with the software running properly and connecting it to the hardware.
- How we pulled it all together and made sure the whole project functioned effectively.

7.1 Hardware Testing

7.1.1 Solar Panel

In order to test the solar panel voltage output, we used a voltmeter. We were also able to use the probes of it to connect to the wire coming out of the thin film cells to find the voltage generated by the flexible thin film cells by facing it to the sunlight. We were able to get a voltage of about 6 Volts of peak voltage. It is about the correct voltage that a thin film cells solar panel should display.

For the thin film solar panels and the battery to be tested correctly and efficiently, we connected the DC output of the solar panel to the DC input of our battery. If the battery charges correctly, that means the battery is tested correctly.

On the other end, to test if the V44 battery is functioning and is capable of also charging other components, we had to connect a cable to the battery's USB port; it charged the phone and then that means the battery is tested correctly.

In order for us to test the battery, once we started charging it, the color of it was red. After at least eight to ten hours of charging, the color changed to green. That actually means that the battery is tested correctly.

UL 1642, Sec 10	Short-Circuit Test	Short circuit the cell through a maximum resistance of 0.1 ohm; testing at 20°C (68°F) and 55°C (131°F); testing of fresh and cycled cells
UL 1642, Sec 11	Abnormal Charging Test	Over-current charging test (constant voltage, current limited to 3X specified max charging current); testing at 20°C (68°F); testing of fresh and cycled ("conditioned") cells; seven hours duration
UL 1642, Sec 12	Forced-Discharge Test	For multi-cell applications only; over-discharge test; testing at 20°C (68°F); testing of fresh and cycled cells
UL 1642, Sec 13	Crush Test	Cell is crushed between two flat plates to an applied force of 13 kN (3,000 lbs); testing of fresh and cycled cells
UL 1642, Sec 14	Impact Test	16 mm diameter bar is placed across a cell; a 9.1 kg (20 lb) weight is dropped on to the bar from a height of 24 inches (61 cm); testing of fresh and cycled cells
UL 1642, Sec 15	Shock Test	Three shocks applied with minimum average acceleration of 75 g; peak acceleration between 125 and 175 g; shocks applied to each perpendicular axis of symmetry; testing at 20°C (68°F); testing of fresh and cycled cells
UL 1642, Sec 16	Vibration Test	Simple harmonic vibration applied to cells in three perpendicular directions; frequency is varied between 10 and 55 Hz; testing of fresh and cycled cells
UL 1642, Sec 17	Heating Test	Cell or battery placed into an oven initially at 20°C (68°F); oven temperature is raised at a rate of 5°C/minute (9°F/min) to a temperature of 130°C (266°F); the oven is held at 130°C for 10 minutes, then the cell is returned to room temperature; testing of fresh and cycled cells
UL 1642, Sec 18	Temperature Cycling Test	Cell is cycled between high- and low-temperatures: four hours at 70°C (158°F), two hours at 20°C (68°F), four hours at -40°C (-40°F), return to 20°C, and repeat the cycle a further nine times; testing of fresh and cycled cells
UL 1642, Sec 19	Low Pressure (Altitude Simulation) Test	Cell is stored for six hours at 11.6 kPa (1.68 psi); testing at 20°C (68°F); testing of fresh and cycled cells

Figure 46 - Series of UI Tests Part 1

UL 2054, Sec 9	Short-Circuit Test	Short circuit the cell through a maximum resistance of 0.1 ohm; testing at 20°C (68°F) and 55°C (131°F); testing of fresh cells
UL 2054, Sec 10	Abnormal Charging Test	Over-current charging test (constant voltage, current limited to 3X specified max charging current); testing at 20°C (68°F); testing of fresh cells
UL 2054, Sec 12	Forced-Discharge Test	For multi-cell applications only; over-discharge test; testing at 20°C (68°F); testing of fresh cells
UL 2054, Sec 14	Crush Test	Cell is crushed between two flat plates to an applied force of 13 kN (3,000 lbs); testing at 20°C (68°F); testing of fresh cells
UL 2054, Sec 15	Impact Test	15.8 mm diameter bar is placed across a cell; a 9.1 kg (20 lb) weight is dropped on to the bar from a height of 61 cm (24 inches); testing at 20°C (68°F); testing of fresh cells
UL 2054, Sec 16	Shock Test	Multiple shocks applied with minimum average acceleration of 75 g; peak acceleration between 125 and 175 g; shocks applied to each perpendicular axis of symmetry, testing at 20°C (68°F); testing of fresh cells

Figure 47 - Series of UI Tests Part 2

7.1.2 Power circuit testing.

Our power circuit is composed of the solar panels, battery and the charging and voltage regulation sections. We can test the functionality and performance of the power circuit by checking the output from the solar panels, that is to make sure enough power is coming and the charge in the battery to make sure sufficient power is supplied to the circuit components.

Initially while researching for the solar battery charging indicator, we considered using two commonly used ICs, the LM3914 and the LM555 with an NPN transistor and some LEDs. The LM3914 Integrated chip is a low-power LED voltmeter, it indicates small voltage steps over the 7-16V range for 12V solar panels, which is exactly within our operating voltages for our project. The meter saves power by operating in a low duty cycle “flashing” mode, where the LED indicators show the level of charging of the battery. And the second chip, the LM555 timer, with the help of a transistor and current limiting resistors is used to control the duty cycle and the blinking rates with the help of resistors. However, we decided not to use this indicator for a couple of reasons, first it doesn’t show the state of the solar panel, second aside from blinking to indicate whether the battery is charging or not, it doesn’t give detailed information about the charging and discharging conditions. Plus, it needed specific conditions for configuring. Instead we chose to add a charging circuit, with few LEDs to show the status of the battery and to also

provide protection from overcharging. And for detailed information about the solar panels and the overall system we have the MPPT, which is discussed in figure 49.

The charging circuit LEDs will show the status of the battery, it has three LEDs that show the current state of the battery. First once power is available in the circuit, the red LED will be ON. If this LED is off, it means there is no power in the system, or the solar panels are not drawing power to the system. Then when the batteries are getting charged the green LED will turn ON and once the battery is fully charged, the Blue LCD will go ON. This way we can test the battery's operation.

In addition to our charging circuit, the solar charge controller (MPPT), has a small display that shows the status of the system as well. It has a backlight LCD display for the solar, battery and load (i.e. our water filtration system circuit component's) charge and discharge parameter.

As we can see from figure 49, in the main display we can control the working mode, the float voltage, Discharge connect and the battery type, in our case which is the Lead-acid battery. We can adjust the settings in this controller for optimal or desired charging voltage. This controller also has a built-in load timer and adjustable floating voltage settings that can be calibrated according to our needs. This way with the help of this digitized charge controller we can test and control the charging and discharging operation of the system. Also to maintain the integrity and life span of our battery, if the voltage at the battery drops below 8-volts this solar controller will turn off automatically. hence we can still track the circuit/battery status with the charging circuits LEDs.

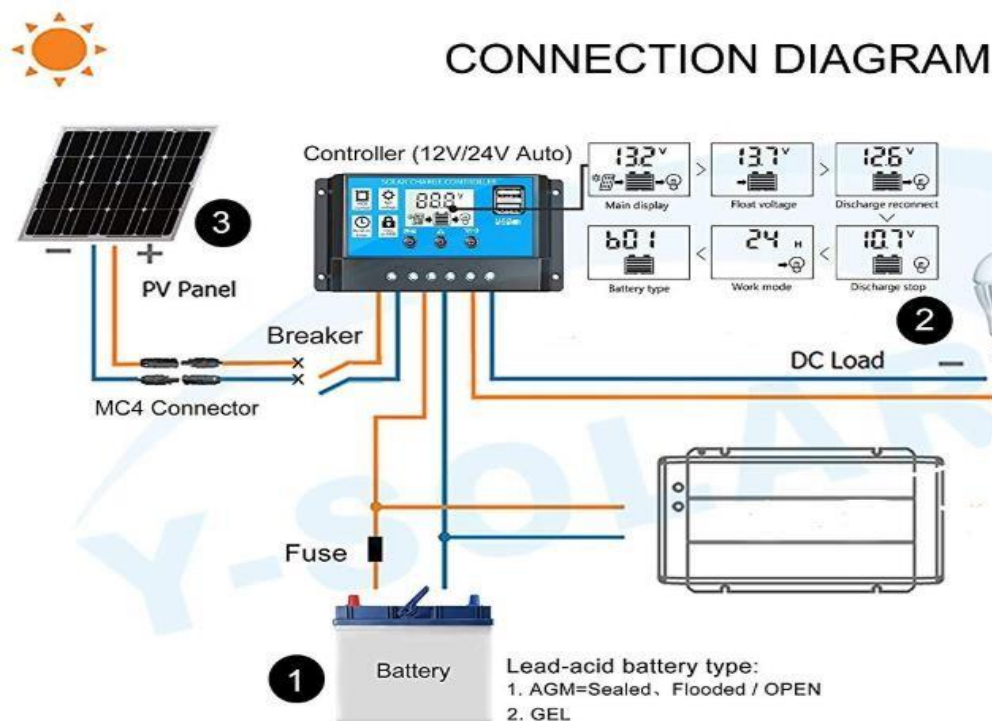

Figure 48 - connection diagram and display modes of charge controller

7.1.3 Microcontroller testing

To ensure that our microcontroller is working properly the MCU will be tested in a few different ways. The atmega328P is an Arduino board compatible controller. This was used to our advantage to test the initial chip with the board to drive an LED by having the user press a button attached to it. This ensures the chip arrives working properly and can handle input (from the button) and deliver an output (driving the LED), then deliver the same test by driving the LED with a button but this time on a breadboard. This tells us if the microcontroller is able to operate off a pre-built board and can deliver the same tasks on standalone boards.

7.1.4 Sensor Testing

The process of testing the sensors will be done by first testing each sensor individually using an Arduino development board. In order to test each sensor, we need to compare the readings received from each sensor against reference values. The temperature sensor for example can be tested by comparing the temperature reading provided by the sensor against the readings from a conventional digital thermometer. The pH sensor on the other hand can be tested by measuring the pH of different liquid with a known pH and comparing it to the readings received from the sensor. By using this type of methods, we are able to determine if there are any discrepancies between the readings from each sensor and the values that they should be returning.

After testing each of these sensors individually we are then able to test them all together by combining all the sensors onto one breadboard in order to test them once more. It necessary to see if the microcontroller can handle the data of all the sensors simultaneously. To do this we have all the sensor send their data as frequently as possible. This will allow us to see if there is any error in the readings in this scenario or if the microcontroller can handle it. It is extremely important that the data from each sensor is accurate and reliable because the data from these sensors determines if the filtered watered from the system is safe for consumption or if the system is being used outside its capabilities.

7.1.5 LCD Testing

Liquid Crystal Displays (LCD) are found in all sorts of different appliances and equipment. They were first used in calculators and digital display watches in the late 1970s and now they have progressed in all sorts of displays including televisions, called LED televisions are actually LCDs. LCDs have advantages in that they are very easy to manufacture and mass-produce so they can be made quite inexpensively, and they are very versatile devices. The LCD we used is a very simple monochrome LCD. They are either two or four lines displays, and we purchased it inexpensively and it was used with the Arduino. LCD displays have a lot of advantages; the fact that they are outside from being low cost and they are

also very low current so they will not take a lot of power. That made it ideal for battery devices and it was certainly nicer than using a serial monitor in our water filtration system.

The display we used is called the 1602 display. It has sixteen characters across and has two rows. We utilized it with an i2c adapter which allowed us to use the i2c bus to communicate with the display which drastically cut down on the number of wires we needed to connect to the display, so they were handy devices to have. On the LCD 1602 display we used, the first pin is called ground (GND), pin 2 which is labeled as VDD is the 5 Volt power supply for the display. Pin 3 v0 is the input pin for the brightness control for the display. Pin 4 called RS is the register select pin. Pin 5, RW, is the read/write pin. Pin 6 labelled EN is the enable pin. Pin 7 through 14 are the parallel data input pins. Pin 7 is data 0, pin 8 is data 1, pin 10 is data 3, pin 11 is data 4 and until it reaches pin 14 which is data 7. Pin 15 is labeled with an A is the anode of the backlight LED and last, pin 16 which is often labeled with a k is the cathode of the backlight LED.

The display works on parallel data. In order to make less wire connection, to the microcontroller, we ran the display in half byte mode and in this case, data pin D4 through D7 are used to transmit one half of a byte at a time. That way, we cut down on the number of wires we needed to run to our interface. Since the Arduino comes with a library called liquid crystal, and we will be using that library.

To connect our temperature and humidity gauge using an LCD along with a temperature sensor. In order to build and display at the same time our temperature and humidity sensor, we needed to add our temperature and humidity sensors device to our circuit. We hooked pin 1 to the 5 volts of the Arduino. Pin 2 is the sensor is its output and that went to digital pin 7 on the Arduino. Pin 4 of the sensor of the sensor is the ground connection and this goes to the Arduinos ground. Pin 3 unconnected.

Once we hooked it up and made sure all the connections were properly made, we had to make sure the temperature and humidity sensors used some of the libraries from Arduino. Since the Arduino came with different libraries, we had to download Arduino, installed them and used the appropriate ones that will be used in the application in our water filtration system. The on that we used to achieve this task is called the library 8c SR 0 for ultrasonic sensor, these were installed in the library manager, and we needed both, the unified sensor library and the DHT libraries from Arduino.

Once they were all installed, we started the program in order to display the temperature and humidity on the Liquid Crystal Display (LCD). Once the wire library for i2c and the liquid crystal library, we included the DHT library from Arduino. We defined the LCD pin out that our adapter used, and we set up the adapter address. With our sensors, we defined few pins: pin 7 is the output connection and we defined the type of sensor as a DHT library that would handle

a number of different sensors. Additionally, we set up the connections to the LCD and created an object called LCD and defined a couple of variables: one which defined our humidity and one which hold our temperature value. After that, we set up the sensors for normal operation.

Next, we went into our setup once, we set up our display type as sixteen by two lines and we initialized our sensor. Once done, we went to the loop with a delay then we will get the humidity and temperature from the sensor and they were stored in the two variables we defined earlier. We then cleared the LCD display and we printed to temperature on the top line, so we set the cursor at zero, printed the actual temperature and add a/c since the temperature we measured is in degree Celsius. Last, we set the humidity value with a percent symbol. The display flashed about every couple of seconds and will occasionally refreshed itself with a different number as it is reading about every two seconds.as how we set it.

7.1.6 Filters Testing

The correct operation of the different water filters used in this project is a very important and delicate part, since it could affect directly the health of the user if the processed water does not meet the required health standards. The main goal of our project is for the product to be able to process and filter sources of water found around rural and urban areas in developing countries. These water sources usually contain solids and different types of bacteria that have to be eliminated by the system of filters designed by the group for this project. According to the NCBI (The National Center for Biotechnology Information) the most common bacterial diseases transmitted through drinking water are cholera, gastroenteritis, typhoid fever, bacillary dysentery, and acute diarrheas. These bacterial diseases are most common in undeveloped countries were clean water is not available to a large portion of the population. For this reason, the testing of the filters and their operation with the device was taking very seriously by the team.

Our group decided to first test each of the filter individually to ensure the correct operation of them without the intervention of the other filter, because as explained previously the filter system designed for this project will improve exponentially the quality of water produced. The first filter that will be tested is the sediment filter since this is the first face of the filter system and for this reason will be in contact with water first. The purpose of this filter as explained in part 3.2.5 is to eliminate any suspended solid found from water, this filter will be tested in different sources of water to ensure its correct operation. The second filter that will be tested is the pre-carbon filter this filter main purpose is to remove chemicals and odor active matters from water, it will also be tested in multiple sources of water. Both of these filters can be easily tested, since they deal with contaminants that can be either seen or smelled and because of that their testing process can be is very basic.

The last two phases of our system involve an ultrafiltration membrane and a ultraviolet water purifier. These filters main purpose is to remove bacteria and

microorganisms found in water, for this reason and the importance of both of these filters to the outcome of the product their testing will involve different steps. To ensure their proper operation our group decided to test the filters with sources of water with high probabilities of containing different types of bacteria. The sources of water chose were lake and rivers since these sources are considered large ecosystems, and thus encompass broad number of bacteria and microorganisms. Our group will obtain samples from these sources and filter them individually with each of the filters. After the water has been filtered different tests will be applied to the water to assure that any contaminant has been eliminated.

The last part of the testing process for the filters will be to test the whole filter system. This will be done similarly to the way we are planning to test the ultrafiltration membrane and the ultraviolet purifier. After the filter system is set up and all four filter are connected and ready to be used our planed is to test it with water from different sources, ponds, lakes, rivers and wetlands are our main focus since these are the most common sources of water found in developing countries. As said before these sources are large ecosystems that could carry different diseases if the water is consumed without the proper treatment. Samples of these sources will be filtered by our system and tests of pH, turbidity, presence of bacteria, among others will be implemented to the water to ensure it meets the required health standards.

7.1.7 Bluetooth Module Testing

The proper functioning of the Bluetooth module depends on its connection and interaction with the microcontroller which involves both the power provided from the microcontroller to the module and also the information delivered to it. To begin the testing of the module we have to ensure that the devices in charge of the operation of it are working properly first and after that the different aspects of the Bluetooth module can be tested. The different aspects that will be tested are its transmission of information between the microcontroller and the app developed for our device, its correct operation in an extended period of time, and its connection with different android devices.

The information transmitted by the Bluetooth module will be first delivered to it by the microcontroller, this information is the pH, temperature, turbidity, and flowrate of the water. All of these values and information will be then delivered to the application to be processed and displayed by it. To test that the Bluetooth module is working properly we will compare the information displayed by the application and the one displayed by the LCD screen. This will ensure that all the information is delivered and that the correct values are been received. We will test this several time since the precision of these values is essential information for the user of our product.

Another important aspect to be tested is its functioning through extended periods of time, since our device will be constantly gathering information about the state of

the filtered water which could be changing constantly. To test this our group will leave both the microcontroller and application working for approximately 3 hours, requesting information from the microcontroller by the app every 20 minutes to ensure that the module is not turning off when it is not been used and also verified that the information been transmitted has been updated. We will also be testing that the power provided to the module does not fluctuate, this power provided by the Arduino pin is essential for the proper operation of the module and it could make the module to stop working is the amount of power been delivered drops.

The last aspect to be tested is the connection of the Bluetooth module with different devices. Our application will only work with android devices, so it is important for our filtration system to establish a good connection with the different devices available. Our plan is to test the Bluetooth module connection and its transmission of information with different android devices, such as different brands of smartphones and tablets. We believed connecting to android devices is extremely important since android is the main mobile operating system used across the globe and specially in developing countries where android devices are most of the time the cheapest and most reliable options available.

7.1.8 Water Pump Testing

The water pump that the group chose for the filtration system is the Amarine-made Water Pressure Pump as explained in section 3.3.3. For this water pump to operate at its optimal capacity it requires 12 volts. Since our product uses solar power to supply energy to the whole system the amount of voltage that can be provided to the water pump is limited. After some research our group found out that the Amarine-made water pump can function well even when half of the voltage is provided. However, when the voltage decreases the pressure and the water flow of the pump also decrease considerably. To test the water, pump the group decided that different factors have to be checked. First, if the amount of pressure obtained when the voltage is decrease is enough for the water to go through the filter system composed of four filters. Second, the operation of the water pump in extended periods of time, and finally the flow rate of the water pump.

The estimated voltage that our device can provide to the water pump is 6 volts. This amount of voltage is enough for the water pump to operate with decent pressure and flow rate. However, since our filtration system is composed of four different filters our main concern is if the pressure of the water pump will be enough for the water to go through the four filter and maintain a constant and suitable flow rate. One of our main goals is for the user of our device to be able to obtain large amounts of water in short periods of time because of this we will test the water pump together with the filters and vary its voltage to obtain a desirable flow rate. After several tests have been made, we will do the respective adjustment to the distribution of power of our device depending on the results. Our group believes this is the correct course of action since the flow rate of our device is an important factor for the user of our product.

Another important aspect of the water pump is its operation through extended periods of time. This will depend on the power been provided to the pump and the quality of the water pump itself. To test this, we will test the water pump for approximately 2 hours. Throughout this time, we will check if both the pressure and the flow rate fluctuate, and we will also be able to monitor the amount of power been provided. This will allow us to determine if the water pump that we chose works well with our device or if there is any external problem that causes the power to oscillate.

7.2 Software Testing

7.2.1 Microcontroller Software

The testing of the microcontroller software will go hand in hand with the testing of each of the devices connected to the microcontroller. The microcontroller software is responsible for reading the data from the sensors, storing the data in the microSD card, displaying the data to the LCD screen, alerting the user in case something is wrong in the system, and connecting to the smartphone and sending the stored data using the Bluetooth transmitter. For this reason, we need to test correct functioning of these parts first to then test the microcontroller software.

First, we need to test each sensor individually to see if they were working correctly and if the microcontroller is receiving the correct data from each of them. To do this we compare the readings received from each sensor against a reference value. After making sure that each sensor is working correctly, we then test them all together. It necessary to see if the microcontroller can handle the data of all the sensors simultaneously. To do this we have all the sensor send their data as frequently as possible. This will allow us to see if there is any error in the readings in this scenario or if the microcontroller can handle it.

Our next step is to check if the microcontroller software is accurately displaying the data in the LCD display, as well as checking if it is displaying the proper alerts when necessary. To check that the information was displayed correctly we will again check the sensor reading against reference values to determine it accuracy. To check if the microcontroller is displaying the proper alerts, we will test the scenarios for each alert individually. For example we will use hot water to check if the microcontroller alerts the user that the water temperature is outside the permitted range for the filters, we will check if the leak sensor alerts the user when there is a leak, we will check if the microcontrollers alerts the user that the water flow is too low for the operation of the system, etc.

Next, we need to test the correct working of the write function that stores the data from the sensors' readings to the microSD card. This is done by extracting the card from the microSD card module and using a computer to check that the data is indeed stored correctly there.

The last part for the microcontroller software testing is to test that the microcontroller is connecting and transmitting information to the smartphone through the Bluetooth transmitter. To do this we check that a solid connection between the microcontroller and the smartphone can be established and that they can communicate with each other. Once this is done, we test if the microcontroller can in fact correctly send the data stored in the microSD card to the smartphone.

7.2.4 Smartphone Application Software

The testing for the smartphone application will be carried initially throughout the developing process. As each part of the application is created every one of the individual features will be tested on Android Studio. This will allow us to catch and correct any bug present in the software more easily.

After completing each individual part, the whole application is tested as one on an Android device emulator. This will allow us to see if each part of the software is interacting correctly with each other and to safely test the application for any potential bug.

When the application is completely tested on an emulator, we can then install it in an Android device for another round of testing. In this step the application will be tested by people outside the development group to see if they can find any bug that causes the application to crash. After this is done, we can then test the connectivity between the application and the microcontroller through the Bluetooth transmitter.

7.3 Device Setup

From the beginning of this project one of our main goals has been to achieve a user-friendly setup that will be convenient and intuitive to manage for anyone. As explained in previous parts the design of our project will consist of a waterproof case with the respective filters and parts inside of it. The solar panels will be placed on top of the case and they can be either attached or detached at the user convenience this is an important feature that will allow the one using the device to place the solar panels where the sunlight face them directly thus optimizing the recharge time of the battery.

To start the device a switch will be placed at the side of the case to allow the user to turn on or off the device. Once the switch is on the positive side the water pump as well as the microcontroller, the different sensors, the Bluetooth module and the ultraviolet purifier will turn on and be ready to use. When the device is on one of the hoses will start suctioning water from the source while the hose attached at the end of the water filtration system will start delivering the filtrated water into the water tank. The LCD display of our device will start to automatically show the pH,

temperature, turbidity, and flow rate of the water immediately after the sensors get in contact with water.

To use the application the user would simply have to install it first. The application will be available in Google Play Store for all android devices. Once the application has been installed the user will be required to connect his/her device with the water filtration system via Bluetooth. After the connection is successful the application will allow the user to manage and operate all the different features available. These features were previously explained and described in section 6.4. All of the features will be easy to use and will provide essential information to the user about the state of the filtered water, the filters, and the device.

The maintenance of the water filtration system will also be very simple. The only parts that would have to be replaced over time are the filters. The different filters chose for our project were carefully selected and all of them have a minimum lifetime of approximately 1 year. When one of the filters needs to be replaced this could be easily detached from the device and changed with a new one. More information about the design and connection of the different filters can be found in section 5.2.4.

Another important feature available to all the user is the leakage sensor placed inside the waterproof case. Even though all the different parts that are not waterproof of our device will be safely protected by molded plastic that will keep water to get in contact with them, the leakage sensor will inform the user that there is a problem either with the connection of the filters or one of the two hose attached to the device.

8. Administrative Content

In order for our project to be successful, teamwork, hard work, dedication and time management played a huge factor in the completion of our paper. Every team member was assigned a specific task at the beginning of every week and we made sure we met at least once a week to gather our work and put it all together in order to meet the deadline.

This section covers the following:

- The starting dates and deadlines for the various assignments that were given throughout the semester.
- The cost of every component needed in our project as well as the total cost of our water filtration system using solar panels.

8.1 Milestone Discussion

In this section, we covered the milestone table for Senior Design I which includes all the assignments that were given to us throughout the semester with deadlines to meet.

Every major task was divided into multiple parts: once different tasks were assigned to each team member, we set a deadline to meet and gathered all the information into a draft. After each draft and all the research were completed, we gathered all the components for testing and refined our paper.

Senior Design I			
Task	Start	End	Status
Brainstorming and Find Ideas	09/01/2019	09/10/2019	Completed
Give Sets of Task to Each Team Member	09/10/2019	09/15/2019	Completed
Documentation Due			
First document due: Divide and Conquer	09/10/2019	09/20/2019	Completed
Assign to Each Member Sections	09/20/2019	09/21/2019	Completed
First Draft	09/22/2019	09/25/2019	Completed
Second Draft	09/26/2019	09/29/2019	Completed
Final Draft	09/30/2019	10/04/2019	Completed
Refined, Research and Design			
Find Components, Comparisons	10/10/2019	10/17/2019	Completed
Electrical Section: Circuit Design and PCB	10/18/2019	10/25/2019	Completed
Gather All the Components and Testing	10/28/2019	11/05/2019	Completed
Final 120 Pages	11/22/2019	12/02/2019	In Progress

Table 35 - Senior Design I Milestone Table

At the beginning of the month of September, our main goal was to brainstorm and find ideas. We started off by giving each other few days to think about ideas to come up with that would make a difference in somebody's life. Looking at the time frame that was given to us and the budget that we set for the entire project, we all came up with the water filtration system using solar panels. We knew that not only it would make a difference in somebody's life, but it would also give us time to do research as far as what parts and components are needed given a time frame.

At the end of our first meeting as a group, we decided to go for the water filtration system using solar panels. Once we all came up with the same idea that is when we agreed to give a set of tasks to each team member and have a deadline set for the first set of tasks. We divided the work as follow: one member was assigned the solar panels, team member two to look at microcontrollers, team member three to look at batteries and team member four to look at UV lamp and filters to purify the water. We then set up weekly meetings, usually for few hours at a time and discussed our findings, shared our point of views on different ideas and came up with a group decision. For the first paper due called Divide and Conquer, the main goal of this paper was to create a technical content that has the following: the goal, specification, technical objectives, and requirements of our project. The research and investigation we made as far as if there are any projects similar to the one, we want to create, and also the impact on the realistic design constraints including economic, environmental, social, political, ethical, and health and safety. This first paper of the semester was to arrange our project into different parts that will not only contain a design overview and technology but would also parts that we would be using and the impact it would have on people's lives. Once the first paper was submitted, we were assigned another paper.

This time, we had about few weeks to complete it and it had to include more details on our project: for the team member who was responsible for the microcontroller, we had to include the design layout for the front end and made sure the following information is displayed correctly and with accuracy: pH, turbidity, and temperature, and also when one of the different filters needs to be changed. In addition, we emphasized on the output stage of the design including programming and interfacing an LCD display, implementation of a charging station. We included the research on all the different types of humidity and pH sensors and we made sure the following was on the interface application: the settings, options given, and it also gives a personable front page to the user who can actually customize what they want to display on the application. We added the Printed Circuit Board (PCB) and the soldering of multiple electrical parts as well as the research of different PCB design software and the different PCB manufacturers. Whoever was responsible for the solar panels, we had to add the research we made based on the performance, layout, cost-effectiveness, as well as the energy efficiency, size, voltage, current, weight, and portability. We mentioned the different manufacturers that sold different solar panels and made sure the selected solar panels have the correct input and output voltage, and the current for our water filtration system. The selection for a lightweight solar panel that had removable magnets for easy

portability had to be included in the paper and the selection of the appropriate case that will fit all the electrical components, filters and UV lamp for the water filtration system. Research on the multiple constraints the water filtration system involved from funding, time, to size constraint.

In addition, we added the focus on the research of the different filters available on the market, as we need a UV filter for clearing the water and another filter to pump the water out. Also responsible for the research of these specific filters: pre-carbon, sediment and ultrafiltration system that are currently available on the market, compared them and selected the appropriate one based on the size, cost, and lifetime and power consumption. We included the thoroughly explanation of how unpurified water goes inside the filter and goes through many stages in order to get clean and purified water as the output by using different pumps and filters.

We also included the research of most electrical components, gathered all the electrical components necessary for the breadboard testing in the paper as well as the design and test circuit using software and breadboard testing. The different types of batteries and the selection of the appropriate one, based on the capacity, gravimetric capacity, and End of Discharge Voltage (EODV) as well as the constant-voltage charger and constant current charger were included. We included the selection of the appropriate one that suits our water filtration system by looking at the different voltage available and by looking at the different current given. The creation of the Printed Circuit Board (PCB), the soldering of multiple electrical parts, and the research of different PCB design software as well as different PCB manufacturers was added. And last, for the one-hundred-page paper, we included the designed and created schematics for the multiple electrical parts using the software called Eagle in our water filtration system using solar panels. Once the one hundred pages paper was submitted, we were given few weeks to complete the final paper.

For the last assignment, we were required to write one hundred and twenty pages. We were asked to make few adjustments to the last paper we submitted by including the following: the schematics, the bills of materials (BOM), and an evaluation plan. We had to help one of our team members since he is the only one in our group with an electrical engineering degree. We all worked together as a team and made sure every team member got their task done and if one of the team members had some issues with their tasks, we were always there to help each other out, no matter the circumstances. In order to complete this last assignment, we had to meet multiple times a week to make sure all the components are chosen properly, all the tables and pictures are numbered, all the references cited, all the appendixes and that all the parts are functioned together without any issues and that all the testing is working well.

8.2 Budget and Finance Discussion

In this section, we covered all the components needed for our water filtration system. We included the price of each item, as well as the quantity we needed for each and every one of them. Some components took longer than expected to arrive, but we managed to gather all the components by the final deadline. We also discussed our project if it was sponsored or not.

Component	Price	Quantity
Case	\$70	1
Micro-Controller	\$3.5	1
Humidity Sensor	\$4.5	1
Temperature Sensor	\$5	1
Barometric Sensor	\$3.25	1
PCB	\$35	2
Micro-Controller	\$3.28	3
Solar Panels	\$180	3
Pre-Carbon Filter	\$15	1
Sediment Filter	\$7.99	1
Ultrafiltration Membrane	\$19	1
UV Lamp	\$53.99	1
Battery	\$69	1
Wi-Fi Module	\$7	1
Miscellaneous Parts	\$30	Variable

Table 36 - Budget Table for All the Components Needed

All the components for our project had to be carefully selected, from the biggest component, the solar panels, to the smallest components, the sensors. The budget we set at first was \$300 for the entire water filtration system using solar panels but after few minor setbacks, it ended up being more than we expected. Some parts ended up costing more money than we expected, and we also needed more filters than we expected. Some parts we ordered did not get on time as expected so we had to pay extra money for the shipping which ended up increasing our budget.

We decided to share the cost of every single component evenly by making sure all the receipts were kept. Since the cost of the entire project cost more than expected, we tried to get a sponsorship from different companies, but we did not end up getting any sponsorships.

8.2.1 Estimated Cost of Device

For this project, we divided all the components with each team member, and we were given a budget limit. First, looking for each and every single part was difficult enough because none of us had previously bought electrical parts or anything related to solar panels, but we also had to compare the different prices offered by many websites. The cost was one major factor that made us decide to pick one website over another. Another factor that we had to take into consideration in the estimated cost of our water filtration system was the cost of shipping. Most websites we ordered parts from offered us free shipping. However, in some cases, we had to pay extra money for shipping because we had to make sure one component worked well with another component in order to move on in our project and meet the deadline. It ended up increasing our original estimated cost of our entire water filtration system. Other issues that we ran into was the fact that some components arrived damaged and we had to spend more money on getting another part and made sure it would arrive in a timely manner. If it was not a damaged component, we also at times, burned out the specific item due to soldering issue or at times, the voltage did not meet the requirement for the specific type of component and as a result, we had to order another part. In the overall cost of our project, we had to include all the small components such as the small pipes, the clamps, and the push fit rings. All of these have to be taken into accounts. They all added up to about thirty dollars.

Taking into consideration all the parts including the small components, they overall total of our project was close to \$471 for our entire water filtration system. We also have to mention that few parts needed to be changed and also replaced due to soldering and also some parts burnt out. Taking all these facts into consideration, the total cost of our water filtration system using solar panels came out to \$500.

8.2.2 Funding

The entire project was funded by the group itself. We did not have the opportunity to get any sponsors, so we evenly split the total cost of the project by all the four teammates. It was difficult for us because some of us do have and work two jobs and we had to make sure we did not go over the budget. We ended up going over budget but what made the project possible were the teamwork, determination, and respect we have for each other. Since we could not find a sponsor for our project and some of us were on a budget, some of us decided to contribute to extra money to help the team members who needed the most. That is why this whole project was the result of working hard and being able to help each other to the best of our abilities.

We started by giving each other parts to be bought and a budget. Along the way, we ended up going over budget for many reasons, some of it because we picked the wrong parts, and the other due to soldering and burning out issues. We told each other to save everything from the emailed receipts to the printed receipts.

We all kept the receipts and emailed receipts as proof of purchase, and then we all met up, added all the numbers together and share the total expenses between the small and large components needed for our entire water filtration system. We ended up being able to have enough funds for our entire project, and a special thank you for those who contributed a little bit more to make this whole project happened.

8.3 Project Roles

In this section of the project, we discussed in detail all the tasks each team member was responsible for. All the parts chosen during this entire process was discussed by the entire team. We all then came to an agreement as far as which specific parts would fit in our project and we all came to a mutual agreement.

Cecile	<p>Primary tasks: Responsible for the solar panels: research the performance, layout, cost-effectiveness, as well as the energy efficiency, size, voltage, current, weight, and portability. Went to different manufacturers that sold different solar panels and made sure the selected solar panels have the correct input and output voltage, and the current for our water filtration system. Select a lightweight solar panel that had removable magnets for easy portability, select the appropriate case that will fit all the electrical components, filters and UV lamp for the water filtration system. Research on the multiple constraints the water filtration system involved from funding, time, to size constraint.</p> <p>Secondary tasks: Creates, updates group meetings, and make sure every team member receives a task, and make sure all the deadlines are met accordingly. Proofread the final paper and wrote the conclusion for the paper.</p>
--------	--

Table 37 - Task Delegation Table Part 1

<p>Alejandro</p>	<p>Primary tasks: Responsible for microcontroller selection and learning the programming language and the software program. Design the layout for the front end and make sure the following information is displayed correctly and with accuracy: temperature, pH, turbidity, and when one of the different filters needs to be changed. Emphasize on the output stage of the design including programming and interfacing an LCD display, implement a charging station. Research on all the different types of humidity and pH sensors. Was also responsible for the software creation, design and implementation. Make sure all the team members agree as everything that was on the interface application: the settings, options given, and it also gives a personable front page to the user who can actually customize what they want to display on the application Create the Printed Circuit Board (PCB) and the soldering of multiple electrical parts. Research different PCB design software as well as different PCB manufacturers.</p> <p>Secondary tasks: Make sure that every section, table and figure is numbered and labeled appropriately, including the appendix and the table of contents. Make sure all the components were gathered in a timely manner so all the testing could be done in a specific time frame.</p>
<p>Gabriel</p>	<p>Primary tasks: Focuses on the research of the different filters available on the market, as we need a UV filter for clearing the water and another filter to pump the water out. Also responsible for the research of these specific filters: pre-carbon, sediment and ultrafiltration system that are currently available on the market, compare and select the appropriate one based on the size, cost, lifetime and power consumption. Explain thoroughly how unpurified water goes inside the filter and goes through many stages in order to get clean and purified water as the output by using different pumps and filters.</p> <p>Secondary tasks: Also help in the design of the PCB (Printed Circuit Board) and assists in the multiple stages for the layout of different schematics. Also help with the research of some of the electrical parts with Henok.</p>

Table 38 - Task Delegation Table Part 2

Henok	<p>Primary tasks: Mainly responsible for the research of most electrical components, gather all the electrical components necessary for the breadboard testing. Design and test circuit using software and breadboard testing. Research different types of battery and select the appropriate one based in the capacity, gravimetric capacity, and End of Discharge Voltage (EODV) as well as the constant-voltage charger and constant current charger. Select the appropriate one that suits our water filtration system by looking at the different voltage offered and by looking at the different current given. Create the Printed Circuit Board (PCB) and the soldering of multiple electrical parts. Research different PCB design software as well as different PCB manufacturers and by looking at the different options that was given. Designed and created schematics for the multiple electrical parts using the software called Eagle in our water filtration system using solar panels.</p> <p>Secondary tasks: Made sure team members stayed on schedule as far as the tasks that each team member was assigned.</p>
-------	---

Table 39 - Task Delegation Table Part 3

9. Conclusion

With no prior experience with solar panels or water filtration system, it was an amazing experience and a great challenge for us. What is the most rewarding for us is to be able to make a difference in someone's life by providing them clean and safe water. It will not only help save lives, but it will also give the opportunity for the user to help their significant others, brothers/sisters, neighbors or even strangers.

The main objective of our water filtration system using solar panels was to make sure it was portable, lightweight, and easy to use. We created a software application with the hardware in order to make the application very easy to use and with the most minimalistic effort from the user. The only inconvenience that will require the user to perform a task is when it is time for the user to change the battery or when one of the filters will need to be changed accordingly and when the application will notify the user to replace it.

Since our water filtration system is targeted for underdeveloped countries, mainly Asia and Africa, it is difficult for us to communicate with them since there is a language barrier. That is why the main goal of our project was to make it easy to use with the creation of an application that will use the most common English words such as "On, Off, Change, Battery, Filter" so it will be straightforward and simple for them to understand. Our design is mainly to help underdeveloped countries but it can also be used worldwide and can be marketed to a vast range of users, from

somebody who needs to walk few miles to find potable water to anybody that is stuck on a boat and needs clean and safe water.

The entire development of our project since day one was not as smooth as we expected. Along the way, we have encountered countless difficulties, starting from selecting the right components for the project to designing the circuit to gathering everything together to make it successfully work. Another main issue we encountered was the time it took for certain components. We had to wait sometimes two weeks for the Liquid Crystal Display (LCD) to arrive, knowing that we needed to connect it to Arduino to make it all connect together and display the correct information on the screen. It was stressful at times because we knew that it delayed us and put us behind schedule for what we wanted to achieve during this short period of time frame.

To end this conclusion of our project, we, as a whole team, realized that the completion of this project is not just about passing the class with a letter grade. It is the hard work, determination, and stressful times that made it all worth it. It is the result of four undergraduate students that decided to not give up on each other, learned from each other, and also understood the mistake of others. We grew very close to each other, not only as a team but as a family. We made sure everyone in the team knew what they were doing, and we did not hesitate to help whoever had difficulties with their assigned tasks. It is one, if not one of the best experiences of our lives as it shaped us to be a successful engineer.

Appendix A- Copyright Permissions

-Homemade Water Filtration System

Source: <https://www.instructables.com/id/Simple-Solar-Water-Filter/>

Permission Status: GRANTED

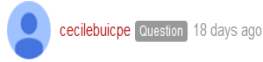

cecilebuicpe Question 18 days ago

Good morning,

My

name is Cecile Bui and I am a Computer Engineering student at UCF. We are trying to build a water filtration systems for underdeveloped countries and I would like to ask you permission (copyright) to use one your pictures as a project idea.

Thank you for your time,

Best regards,

Cecile Bui.

RE: [The Sustainable Living Report] Contact 2

Yahoo/Envoyés *

Rose Sarko <mysstflame@hotmail.com>
À : cicou77@yahoo.fr

16 nov. à 15:45 *

Hi Cecile,

Thanks for reaching out - that sounds like a great project!

We don't own the pictures on our site - they are all public domain or creative commons pictures. There are lots of places to find these, but two of my favorite are <https://pixabay.com/> and <https://www.pexels.com/>. You can also do a Google image search, but do the advanced search, and under the Usage Rights drop-down, choose images that are free to use and share for any purpose: https://www.google.com/advanced_image_search

-Small Thin Film Cells, the best choice for our water filtration system

Source: <https://voltaicsystems.com/solar-panels/>

Permission Status: GRANTED

Cicou joliasia <cicou77@yahoo.fr>
À : helpdesk@voltaicsystems.com

14 nov. à 23:12 *

Hi Calvin,

Thank you for your e-mail. I would like to ask you if it is possible to use one of your solar panels pictures (Copyright) for your Senior Design project?

It is the one I was telling you about, the water filtration system using solar panels.

Thank you,

Best regards,

Cecile B.

Voltaic Support <helpdesk@voltaicsystems.com>
À : Cecile

15 nov. à 14:38 *

Hey Cecile,

Thanks for asking. You're more than welcome to use pictures of our products from the website - simply include something like "Photo Courtesy of Voltaic Systems".

By the way, we do occasionally feature projects like yours on our blog. If you're interested in writing up a walkthrough of your system, we'd be happy to review it and potentially feature it on a post. Let me know when you're finished up with everything if this is something you'd be interested in.

Thanks,

Calvin

Figure 3: Small Thin Film Cells, the best choice for our water filtration system.
Source: <https://voltaicsystems.com/solar-panels/>
Permission Status: REQUESTED

• Cecile B. (Engineering Student at UCF)

Yahoo/Envoyés ★



• **Cicou joliasia** <cicou77@yahoo.fr>
À : helpdesk@voltaicsystems.com



14 nov. à 23:12 ★

Hi Calvin,

Thank you for your e-mail. I would like to ask you if it is possible to use one of your solar panels pictures (Copyright) for your Senior Design project?

It is the one I was telling you about, the water filtration system using solar panels.

Thank you,

Best regards,

Cecile B.

Appendix B – References

- [1] "Simple Solar Water Filter," [Online]. Available: <https://www.instructables.com/id/Simple-Solar-Water-Filter/>.
- [2] "Voltaic Systems," [Online]. Available: <https://voltaicsystems.com/solar-panels/>. [Accessed 01 December 2019].
- [3] "Mighty Max Battery," [Online]. Available: <https://www.mightymaxbattery.com>. [Accessed 01 December 2019].
- [4] "Energco," [Online]. Available: <https://energco.com/product/mohoo-20a-12v-24v-solar-charge-controller-auto-switch-lcd-intelligent-panel-battery-regulator-charge-controller-overload-protection-20a/>. [Accessed 01 December 2019].
- [5] "Sino Volataics," [Online]. Available: <https://sinovoltaics.com/learning-center/components/mppt-charge-controllers-mppt-advantages/>. [Accessed 01 December 2019].
- [6] "EasyGetProducts," [Online]. Available: <https://www.easygetproduct.com/best-solar-charger-controllers/>. [Accessed 01 December 2019].
- [7] "Roboticlub," 05 September 2019. [Online]. Available: http://home.roboticlub.eu/en/iot-open/introduction/introduction_to_iot_communication_and_protocols. [Accessed 01 December 2019].
- [8] "Argenox," [Online]. Available: <https://www.argenox.com/library/msp430/msp430-interrupts-and-low-power-chapter-7/>. [Accessed 01 December 2019].
- [9] S. Bailey, "Diagram of an automated water well system powered by a submersible pump," 2008.
- [10] "Singflo," [Online]. Available: https://www.singflo.com/100psi-dc-small-electric-agriculture-atv-sprayer-pump_p40.html. [Accessed 01 December 2019].
- [11] "The Health and Environment Linkage Initiative," [Online]. Available: <https://www.who.int/heli/risks/water/water/en/>. [Accessed 01 December 2019].
- [12] "Moonbow," [Online]. Available: <https://www.moonbowliving.com/water-purifiers/ro/calisto-water-purifier/>. [Accessed 01 December 2019].

- [13] "pH-meter," [Online]. Available: <http://www.ph-meter.info/pH-electrode-construction>. [Accessed 01 December 2019].
- [14] "Fondriest Environmental, Inc," 05 09 2014. [Online]. Available: <https://www.fondriest.com/environmental-measurements/measurements/measuring-water-quality/turbidity-sensors-meters-and-methods/>. [Accessed 01 December 2019].
- [15] "DigiKey," [Online]. Available: <https://www.digikey.com/product-detail/en/panasonic-industrial-automation-sales/EX-F72/1110-1881-ND/3899413>. [Accessed 01 December 2019].
- [16] "Theory Circuit," [Online]. Available: <http://www.theorycircuit.com/water-flow-sensor-yf-s201-arduino-interface/>. [Accessed 01 December 2019].
- [17] *LM2576 (Texas instruments data sheet)*, Texas Instrument.
- [18] *Texas Instrument Data Sheet*, Texas Instrument.
- [19] "Amarine," [Online]. Available: <https://amarine.store/products/amarine-made-12v-water-pressure-diaphragm-pump-4-3-l-min-1-1-gpm-35-psi-caravan-rv-boat-marine>. [Accessed 01 December 2019].
- [20] "Boeray," [Online]. Available: <https://www.amazon.com/Ultraviolet-Purifier-Purification-Sterilizer-Electronic/dp/B07MJ15RX1>. [Accessed 01 December 2019].
- [21] "DigiKey," [Online]. Available: https://www.digikey.com/product-detail/en/dfrobot/SEN0189/1738-1185-ND/6588606?utm_adgroup=General&slid=&gclid=CjwKCAiArJvBRACEiwAWiqq5y84jQRwpo5IE8VkuZ6-z8KrSHkfTWGY3b0xArl7N3MZLhS5za2hRoCUAIQAvD_BwE. [Accessed 01 December 2019].
- [22] "Newark," [Online]. Available: <https://www.newark.com/dfrobot/sen0161/analog-ph-sensor-meter-kit-arduino/dp/79AC7368>. [Accessed 01 December 2019].
- [23] "Seed Studio," [Online]. Available: <https://www.seeedstudio.com/Water-Flow-Sensor-YF-B3-p-2880.html>. [Accessed 01 December 2019].
- [24] "DFRobot," [Online]. Available: <https://www.dfrobot.com/product-1354.html>. [Accessed 01 December 2019].

- [25] "Arduino," [Online]. Available:
<https://create.arduino.cc/projecthub/millerman4487/view-serial-monitor-over-bluetooth-fbb0e5>. [Accessed 01 December 2019].