

Laser Instrument



Group 9

Luke Hazelton – Computer Engineering
Alexis Lamb – Computer Engineering
Erik Lim – Computer Engineering
Krystyn Wikoff – Computer Engineering

Table of Contents

1	Executive Summary	1
2	Project Description	2
2.1	Motivation	2
2.2	Goals and Objectives	2
2.3	Related Work.....	3
2.3.1	Synthesizers vs Storing Audio Files	5
2.4	Engineering Requirement Specifications.....	6
2.4.1	Project Requirements	6
2.4.2	Physical Device Requirements	7
2.4.3	Software Requirements	8
2.4.4	Application Requirements	8
2.5	System Architecture	9
2.6	House of Quality	10
3	Research and Technical Comparisons	13
3.1	Instrument Frame	13
3.1.1	Research.....	13
3.1.2	Technology Comparison	19
3.1.3	Part Selection.....	22
3.2	Laser Diodes	25
3.2.1	Research.....	26
3.2.2	Technology Comparison	28
3.2.3	Part Selection.....	29
3.3	Sensors and Light Detection	29
3.3.1	Research.....	29
3.3.2	Technology Comparison	34
3.3.3	Part Selection	36
3.4	Physical Input	37
3.4.1	Research.....	37
3.4.2	Technology Comparison	39
3.4.3	Part Selection.....	42
3.5	Display.....	43
3.5.1	Research.....	44
3.5.2	Technology Comparison	45
3.5.3	Part Selection.....	46
3.6	Audio Output	46
3.6.1	Research.....	47
3.6.2	Technology Comparison	49
3.6.3	Part Selection.....	53
3.7	Bluetooth	54

3.7.1	Research.....	54
3.7.2	Technology Comparison	54
3.7.3	Part Selection.....	57
3.8	Musical Instrument Digital Interface.....	57
3.8.1	Research.....	57
3.9	Microcontroller Unit.....	59
3.9.1	Research.....	59
3.9.2	Technology Comparison	59
3.9.3	Part Selection.....	62
3.10	Battery and Power	63
3.10.1	Research.....	63
3.10.2	Technology Comparison	65
3.10.3	Part Selection.....	66
3.11	Audio Storage.....	66
3.11.1	Research.....	67
3.11.2	Technology Comparison	68
3.11.3	Part Selection.....	70
3.12	Application	70
3.12.1	Programming Environment.....	71
3.12.2	User Interface Research	72
3.12.3	Technology Comparison	74
4	Design Constraints and Standards.....	76
4.1	Constraints	76
4.1.1	General	76
4.1.2	Economic Constraints	77
4.1.3	Environmental Constraints	77
4.1.4	Social Constraints	77
4.1.5	Market Constraints	78
4.1.6	Health and Safety Constraints.....	78
4.1.7	Engineering Constraints	79
4.2	Standards	79
4.2.1	Electrical Standards	80
4.2.2	IPC 81	
4.2.3	Communication Standards.....	82
4.2.4	Software Standards.....	82
4.2.5	Audio Standards.....	85
4.2.6	Musical Standards.....	86
4.2.7	General Standards	87
5	Project Design.....	89
5.1	Design Process.....	89
5.2	Hardware and Breadboard Testing.....	89

5.2.1	Instrument Frame.....	90
5.2.2	Laser Diodes.....	94
5.2.3	Sensors and Light Detection.....	96
5.2.4	Physical Input.....	98
5.2.5	Display.....	100
5.2.6	Audio Output.....	101
5.2.7	Microcontroller Unit.....	103
5.2.8	Battery and Power.....	105
5.2.9	Audio Storage.....	106
5.3	Application.....	107
5.3.1	Programming Environment.....	107
5.3.2	User Interface.....	108
5.4	Overall Schematic.....	109
5.5	Software Design.....	111
5.5.1	Software Tests.....	112
6	Overall Integration.....	115
6.1	System Testing.....	115
6.2	PCB Design.....	116
7	Administrative.....	120
7.1	Budget and Bills of Materials.....	120
7.2	Milestones.....	122
7.3	Communication.....	122
7.3.1	Discord.....	123
7.3.2	OneDrive.....	123
7.3.3	Google Drive.....	123
7.3.4	GitHub.....	124
7.3.5	Face to Face.....	124
8	Project Summary and Conclusion.....	126
9	Appendices.....	a
9.1	Copyright Permissions.....	a
9.2	References.....	d

Table of Figures

Figure 1	“Waveforms of a flute [A], oboe [B], and clarinet [C]” [6].....	5
Figure 2	555 Timer-Based Voltage-Controlled Oscillator [7].....	6
Figure 3	Block Diagram Team Responsibilities.....	10
Figure 4	House of Quality Diagram.....	12
Figure 5	Popular Joint Joining Methods.....	14
Figure 6	Basic Frame Design and Harp Frame Design.....	15
Figure 7	Checkered Frame Design and Accordion Frame Design.....	16

Figure 8 Isometric View of Instrument	22
Figure 9 Back and Front Views of Instrument.....	23
Figure 10 Frame Back and Front with Sliding Back Panel.....	24
Figure 11 Adafruit (left) and HiLetgo (right) Red Laser Diodes Permissions in Figure 25 and Figure 26	26
Figure 12 Digi-Key (left) and Lights88 (right) Permissions in Figure 28 (Lights pending permissions)	27
Figure 13 SD057-11-21-011 (left) and PDB-C142 (right) Permissions in Figure 28	31
Figure 14 HiLetgo, SGT516GK, and SFH 3310 Phototransistors Permissions in Figure 26 and Figure 27 (permissions pending for SFH).....	32
Figure 15 Ultrasonic Sensor Diagram.....	33
Figure 16 Rotary Encoder Signal Explanation [26].....	38
Figure 17 Note Frequencies [27]	47
Figure 18 Bass Boost Amplifier Circuit from circuitbasics.com [29].....	49
Figure 19 Secure Digital (SD) Pinout.....	68
Figure 20 Application Flow	73
Figure 21 Example Layout on Breadboard	110
Figure 22 Software Flow.....	111
Figure 23 PCB Schematic	116
Figure 24 PCB Layout	117
Figure 25 Adafruit Red Laser Diode Permission.....	a
Figure 26 HiLetgo Red Laser Diodes and Phototransistors Permissions	a
Figure 27 SGT5516GK Phototransistor Permissions	b
Figure 28 Digi-Key Photo Permissions	c

Table of Tables

Table 1 Project Requirements	7
Table 2 Device Requirements	8
Table 3 Software Requirements	8
Table 4 Application Requirements.....	9
Table 5 Material Comparison.....	18
Table 6 Frame Design Comparison.....	20
Table 7 Frame Material Technology Comparison.....	21
Table 8 Frame Material Technology Comparison (Cont.).....	22
Table 9 Polymer Compression	25
Table 10 Laser Diodes Comparison	28
Table 11 Photodiodes Comparison	34
Table 12 Phototransistors Comparison	36
Table 13 Bourns Rotary Encoder: Three-Pin vs Five-Pin	39
Table 14 Rotary Encoder: Bourns vs Adafruit Package.....	40
Table 15 Potentiometers: AVX vs Alps.....	41
Table 16 Potentiometers: TT Electronics vs Alps	41
Table 17 Rocker Switches: CW Industries vs E-Switch.....	42
Table 18 LCD versus Seven-Segment Display.....	46
Table 19 Instrument Note and Frequency Ranges [27].....	48

Table 20 Speakers: WSP-5008-57 vs WSP-5090-4.....	50
Table 21 Speakers: SP700108-1 vs SP-1208.....	51
Table 22 Amplifiers: Low Impedance Output Comparison	51
Table 23 Amplifier Comparison: 2-Watt, 8 Ohm.....	52
Table 24 Amplifier Comparison: 10-Watt, 4 Ohm.....	53
Table 25 Bluetooth Comparison Chart	55
Table 26 ESP32-SOLO-1 vs ESP32-WROOM-32D.....	56
Table 27 MCU Comparison: ATmega328 vs MSP430 Computing	60
Table 28 MCU Comparison: ATmega328 vs MSP430 Physical	60
Table 29 MCU Comparison: ESP32-WROOM vs CC2642R1F Computing	61
Table 30 MCU Comparison: ESP32-WROOM vs CC2642R1F Physical	62
Table 31 Battery Comparison.....	65
Table 32 Storage Device Comparison.....	69
Table 33 Audio Storage Readers Comparison.....	69
Table 34 Audio Storage Devices Comparison.....	70
Table 35 Necessary Features of the App.....	72
Table 36 App Stretch Goal Features	74
Table 37 Project Constraints	76
Table 38 Economic Constraints	77
Table 39 Environmental Constraints	77
Table 40 Social Constraints	78
Table 41 Market Constraints	78
Table 42 Health and Safety Constraints.....	79
Table 43 Engineering Constraints	79
Table 44 All Standards.....	80
Table 45 Processes and Expected Outcomes for Frame with Contact	94
Table 46 Processes and Expected Outcomes for Frame without Contact	94
Table 47 Processes and Expected Outcomes for Laser Diodes	96
Table 48 Process and Expected Outcomes for Sensors.....	98
Table 49 Processes and Expected Outcomes for Physical Input.....	100
Table 50 Processes and Expected Outcomes for Display.....	101
Table 51 Processes and Expected Outcomes for Audio Output	103
Table 52 Processes and Expected Outcomes for Microcontroller Unit	104
Table 53 Processes and Expected Outcomes for Battery.....	105
Table 54 Processes and Expected Outcomes for Audio Storage.....	106
Table 55 Processes and Expected Outcomes for Programming Environment.	108
Table 56 Processes and Expected Outcomes for User Interface.....	109
Table 57 Device Processes and Expected Outcomes for MCU Software	114
Table 58 App Processes and Expected Outcomes for MCU Software.....	114
Table 59 Processes and Expected Outcomes for PCB	119
Table 60 Project Budget.....	120
Table 61 Bill of Materials	121
Table 62 Project Milestones	122

1 Executive Summary

Music can be one of the most influential aspects of many people's lives. The sound of music is so powerful that it can elicit many kinds of emotions. The history of music can be traced back to ancient times, and the evolution of music today is an enormous progressive development of this history. Music can be produced from a myriad of instruments or objects. The classical piano is a great example of an instrument that has developed over many generations. In modern day, the piano can be seen in many different forms, such as a grand piano or electronic keyboard. Even with an instrument such as a piano that has evolved for many hundreds of years, there are people still inventing ways to create instruments that build upon this foundation. This project's goal is to build upon the foundation that current instruments provide.

The contents of this project's documentation are based upon the design of an electronic instrument, specifically a laser instrument. The laser instrument will be designed with the intention of making an instrument that is versatile and can appeal to a larger audience, whether that is by a favorable design or capabilities of the instrument. In this project, the instrument establishes a twist on modern electronic instruments by introducing laser diodes. The act of breaking a laser projection would cause the musical note to be played through speakers on the instrument. This is a simple action which is good for listeners of all audiences. It makes playing the instrument much easier, in contrast to someone learning how to play a guitar, for example. In order to maintain a greater user experience, the instrument shall have a portable design such that the users could play the instrument in which ever environment they choose. The instrument will also provide the users with a visual aide in the form of a graphical display. This would speed up the process of learning the instrument by corresponding the laser diodes to the notes that will be played via the display. Instead of taking the time to learn which note a string or key is, for example, the user will be able to play real time and see which notes are being played.

Another feature to make this instrument different than a typical electronic instrument is the ability to connect to a mobile application via Bluetooth. The laser instrument shall have a Bluetooth module that will allow users to connect to an application which will provide extra functionality that can enhance user experience without impeding on the physical design of the instrument. Some possible features would be the ability to record the music while the user plays the instrument and then playback the notes the user played. Recording software can be very expensive so having a mobile application that has the ability record music could potentially save consumers money. Although there may be alternatives such as synthesizers, some of the alternatives can easily cost up to a thousand dollars. The laser instrument should be a nice variant that is easy to play, portable enough to carry anywhere, and provide a fun aspect to the electronic instrument.

2 Project Description

This section outlines the motivation for developing a laser instrument, the goals and objectives to be completed, the basic functionality of the instrument, the design constraints and requirement specifications to be met, the standards considered while designing, and the engineering and marketing research conducted in relation to the project. It also highlights several projects completed by other people and groups that served as sources of inspiration for the laser instrument project.

2.1 Motivation

Electronic instruments have gained popularity over the years, as well as various other devices that can produce sounds of a variety of instrument types. This project would be an adaptation of an electronic keyboard by creating a generic laser instrument that can reproduce the noises typically created by a range of standard modern instruments. The team strives to produce a product that is a portable and cost-effective laser instrument which allows users to play musical notes imitated using laser diodes with photo sensors.

By being a single device that can perform with multiple instrument sounds, any user could easily swap between multiple instruments to play in a small span of time. This reduces the number of physical instruments needed to be carried and the number of different physical designs that would need to be learned. In addition, a lightweight and portable design would make it easier to mimic instruments in places that are typically more difficult for the larger and heavier instruments to perform. The laser instrument will be a more portable and cost-effective device compared to the classic keyboard, which can be difficult to transport due to its larger size. The final product of this project would target users who prefer a mobile electric instrument or who would like a fun device to learn basic notes. This product would appeal to both practicing musicians and recreational users alike.

2.2 Goals and Objectives

The overall objective of this project is to construct an instrument that can produce sound via speakers embedded in the device. In its most basic form, the instrument should utilize laser diodes and photo sensors as the instrument's "keys", and the sound produced should be based on user's input using the laser keys. The instrument itself should have a frame that is light weight and can be transported easily. Consequently, the power supply should be portable such that the user could play without requiring an electrical outlet. Thus, the power should require a switch so the instrument can be turned on and off. The cost of the instrument should be kept to a minimum to maintain affordability for users.

Several advanced goals should be executed in the design of the laser instrument. The ability to change the volume should be implemented by including a turning dial which would allow a user to adjust the output volume of the instrument based on their needs. The laser instrument should have the ability to produce the sounds of five different instrument types: piano, string, brass, woodwind, and percussion. Also, the instrument should have a graphical display that allows users to see the corresponding musical note value to each laser diode. A graphical display would increase the ease of use of the instrument and reduce difficulties for the user during usage. The instrument will connect with a mobile device via a Bluetooth module which should allow the recording and playback of the instrument through a mobile application.

The stretch goals of the project should focus on expanding a base mobile application to provide more features and customizability of the laser instrument to the user. In addition to the mobile application being able to record and playback a recording, the mobile application should allow the user to modify the recording with configurable settings such as instrument type and octave levels. This extra functionality would expand the possible combinations of note values, instruments types, and octaves levels that the user can produce from the laser instrument.

2.3 Related Work

During the process of finalizing the design and features of the laser instrument, the team researched previously established models for inspiration. The most frequently occurring designs noted included harp shaped frames, boxed frames, and frameless instruments [1]. The framed designs utilized multiple laser diodes to represent each key in an octave, and the most common method for implementing keys in the frameless designs involved breaking a singular light beam into multiple light beams. This section outlines several frameless and framed projects the team referenced for this project.

A Laser Harp, constructed by Jacob Thompson in Spring 2015, was built mimicking a standard harp. Thompson created a laser instrument that outputs musical notes by playing in the same mannerism as a harp; however, the instrument reacts when laser “strings” are broken instead of plucking harp strings. The laser diodes used for the strings are oriented vertically such that the dots of the lasers point down towards the base of the frame. His laser harp can be customized by changing the volume, scale, and octave output of the instrument. The wooden frame provides a sturdy base for the entire instrument while also adding an aesthetically pleasing design. The frame is enclosed except for one opening on one side of the frame [2]. The team’s implementation of a laser instrument pulls inspiration from some of the features Thompson incorporated in his laser harp such as utilizing buttons and dials to change the volume, scale, and octave that the laser instrument produces.

Another laser harp developed by Yaroshka exhibits many similarities to Thompson’s laser harp. Yaroshka’s design implements a simple wooden frame for

an electronic instrument that mimics the audio output of a harp. The instrument reacts when the connection of a laser beam to a photoresistor is interrupted. This project improves upon Thompson's design since Yaroshka's laser harp includes audio files that more accurately represent the sounds of a harp. Yaroshka's design lacks customizability compared to Thompson's design, but Yaroshka's project is a more realistic replacement for the modern harp since it sounds more familiar to traditional harps [3]. The team intends to use this concept and expand upon the idea by having support for multiple instrument types. This would be an improvement from Yaroshka's design as theirs only supports one instrument sound, the harp.

The team also researched examples of frameless instruments for project inspiration. Pushan Panda designed a frameless laser harp that uses laser lights as a replacement for the standard strings. The most notable characteristics of Panda's project is the frameless aspect of the project design. This is a result of only a single laser being split by a mirror to produce all the necessary notes for the laser instrument. This design uses a photonic approach, versus an electrical adaption implemented in Thompson's and Yaroshka's designs, to detect when a light beam is cut by a user's hand. The photonic approach involves a mirror attached to a motor that rotates in steps, and the single laser is directed toward the rotating mirror. Every step changes the position of the mirror that deflects the laser beam in different directions. The key to execute this properly lies in the speed of the steps. If the steps are executed at a fast-enough rate, the multiple resultant beams will appear simultaneous [4]. Panda's design is limited by requiring a safe area to project laser beams, requiring potential safety eyewear to operate the laser harp, and depending on the accuracy required to use the stepper motor to determine at which instance the single laser has been broken. The team's laser instrument project will improve upon these limitations by implementing the electrical approach and designing a closed frame laser instrument.

Another example of a frameless laser harp is a two-octave laser harp project built by Evan Reynolds in Fall 2015. Reynolds' laser harp utilizes the same photonic approach as Panda's by directing a laser beam towards a mirror on a rotating stepper motor. The difference between their laser harp implementations is that Panda's design cannot dynamically alter the octave of the notes being output by the device during runtime. Reynolds' laser harp supports two octaves by including SONAR in the design of his harp. Without a frame and using a single laser with a mirror and motor stepping tool, ultrasonic sensors were used to more accurately determine the position of a user's hand with respect to the instrument. This judgement allowed dynamic adjustment of octaves for the notes produced [5]. Reynolds' laser harp project was limited by the same safety requirements and mechanical feature as Panda's laser harp. From Reynolds' project, the team aims to implement a sonar sensor or alternative component for the laser instrument project to also support multiple octaves during device utilization.

2.3.1 Synthesizers vs Storing Audio Files

There were two methods the team chose to consider for playing the instrument's music files. The device could either have hardware to synthesize music or play audio files. To synthesize the sounds of instruments, waveforms as shown in Figure 1 would have to be recreated using timers and other hardware. Using synthesizers to recreate these waveforms has been implemented by many hobbyists, and tutorials for this method are widely available online.

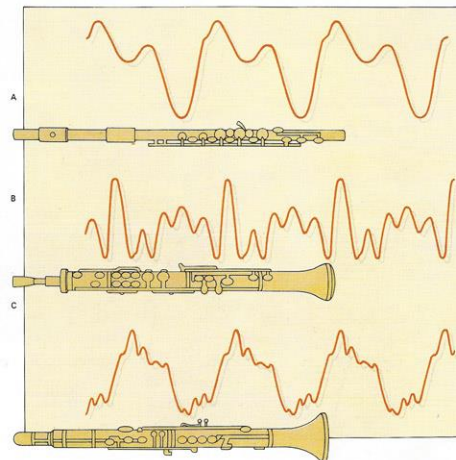

Figure 1 “Waveforms of a flute [A], oboe [B], and clarinet [C]” [6]

Typically, 555 timers are used in most of these analog component-based designs for synthesizers. These timers normally can synthesize waves like the given instrument. Many of these synthesizers require either more expensive circuitry, more components, or a combination of both to properly recreate the waveform [7]. When comparing the sound quality of the synthesized instruments to the original, the difference is notable enough. In a project where sound quality is important, this could distract the user. With synthesizers, there isn't a chance of delay due to a component not having enough computing ability. As shown in Figure 2, the speed of the output is dictated only by the analog electronics that create the synthetic instrument notes.

Using synthesizers to recreate the instruments the team desires for the device would also limit the capabilities of the instrument. There would be no ability to expand and add extra instruments or change the instrument sounds in the device. Furthermore, these recreated instruments would need thorough testing to sound like the imitated waveform. For each instrument, a circuit like Figure 2 would be needed to create notes similar to the instrument the circuit would mimic. This would mean a total of 5 circuits, each one needing testing for every note to sound like the mimicked instrument. Instead of wasting this space on discrete circuitry, the space

must be chosen to give the project direction and establish fixed functionality desired by the team. These core functionalities chosen are based on the basic needs to have a successful laser instrument and the base features that will act as the foundation for extra features the team plans to implement. These requirements are outlined in Table 1.

Table 1 Project Requirements

Requirement	The project shall...
R.P.1	Support one full octave of musical notes which is composed of 8 individual notes
R.P.2	Support at minimum the natural accidental notes
R.P.3	Support the audio of 5 different instrument types: piano, string, brass, woodwind, and percussion
R.P.4	Support regular operation with the use of one hand
R.P.5	Have the ability to turn the device on and off at will
R.P.6	Connect to a mobile application

2.4.2 Physical Device Requirements

The physical device's frame is required to allow enough space for all internal components to fit, while also being considered competitively portable compared to other devices. To do this, the minimal external dimensions are required to be at least the size of the printed circuit board, graphical display, speakers, and physical input devices. These are the largest and most prominent components that affect the size needed for the frame of the device, which dictates the total size of the final product. To maximize portability, the material used in the final product must be considered relatively lightweight.

The bottom of the instrument must be flat so that it can be played standing on the bottom base with no difficulty and no assistance from the user. For ease of use and support of multiple musical notes, the width of the device is required to be longer than its height, and the width is directly related to the spacing required between each laser diode on the final product. Failure to keep in mind spacing need for core components such as the laser diodes and photo sensor could result in a final product that is unappealing or difficult to operate by a larger audience of people.

The instrument must have the ability to come apart without compromising the device's functionality. This must fully expose all internal components for the purpose of fixing any electronic errors during or outside of runtime. When not apart, the removable portion must be locked into place to prevent damage from regular use and other hazards. These requirements are outlined in Table 2.

Table 2 Device Requirements

Requirement	The device shall...
R.D.1	Remain within the dimensions of 12 inches long, 18 inches wide, and 4 inches in depth
R.D.2	Weigh no more than 10 lbs.
R.D.3	Have a minimum of one graphical display to label the corresponding musical note to each laser diode
R.D.4	Have a lifespan of 1 hour or more of regular operation
R.D.5	Have speakers that output audio as “keys” are played
R.D.6	Use laser diodes with photo sensors to simulate instrument notes/keys
R.D.7	Have a minimum of 1.5 inches between each laser diode
R.D.8	Have a removable back piece that allows ease of access to internal components
R.D.9	Have a Bluetooth module component to allow for communication with an application
R.D.10	Have real time audio file playback

2.4.3 Software Requirements

The software requirements are in place to assist in the development of the most efficient program possible. Being the brains behind the laser instrument, an efficient software must be developed. These requirements will set standards for how the logic may be developed.

Table 3 Software Requirements

Requirement	The Software shall...
R.S.1	Have real time audio file fetching
R.S.2	Display required information necessary for regular use

2.4.4 Application Requirements

The application requirements are in place to assist in the development of the most efficient utilization of the mobile application component of the project. Outlining key requirements will contribute to any decision-making about what features the application should include to ensure extra functionality for the user without impeding on the laser instruments primary operations.

Table 4 Application Requirements

Requirement	The Application shall...
R.A.1	Have a minimum connectivity distance of 3 ft
R.A.2	Support at minimum the natural accidental notes

2.5 System Architecture

Figure 3 shows the breakdown of the work to be done and which team member oversees each task. The only color not labeled, dark gray, represents work that would be divided among team members. Colored boxes link team members to their portion of the project to manage. The colored arrows dictate how the project pieces connect to other components. The Central Processing Unit (CPU) or Microcontroller Unit (MCU) and Bluetooth are not directly assigned because the team will collaborate on their research and development. The greyed blocks of the app functions are not directly assigned due to one member overseeing the overall app. These portions of the code will be delegated as the need arises if the team member supervising the app is unable to handle it all.

The components have completed the research stage, and most have been purchased. Although the speaker is notated with the to be acquired icon, a test speaker will be used in the interim to verify other portions of the system work. The speaker has been tested to show that it is capable of most frequencies various instrument types use. The overall system itself stems from the chosen CPU with Bluetooth capabilities. The chip also has Wi-Fi, but the group doesn't plan to utilize that feature. Going outward from the CPU/MCU, graphical display, rotary encoder, lasers, and photo sensors have all been acquired. These parts are currently still in the testing phase in order to verify that they will be satisfactory for use in the final design.

The lasers and photo sensors have already been tested to ensure the majority of received parts operate properly. Some interaction values were recorded, but due to lacking a structure in which to properly set up the diodes and sensors in the predefined distances, the testing will need to be continued using the process outlined in the testing section later in the document. The battery section was one of the last sections to complete because the voltage requirements of the other components determine the overall power consumption of the system. This information is necessary to satisfy the project's hour-minimum requirement of portable power. The application is in the early stages of development since the primary focus of the project has been the construction of the laser instrument. The mobile application also has the fortune of having many related native libraries to cover the project requirements. These resources are well documented and therefore, the app can wait for development until all the resources that take time to develop have the process of development started. The user-side design and overall quality of user experience would be part of the final stages of the project

development. The first parts of the app to be worked on will be the Bluetooth connectivity, one of the major requirements of the mobile application.

A few components mentioned in the Research and Technical Comparisons chapter of the document are not pictured in Figure 3 since they are sub-components of the ones already outlined in the Block Diagram. The first of these sub-components is the on/off switch, mentioned in 3.4.1.3. This part will fall under the battery portion of the circuit as a way of keeping battery power from the rest of the circuit. Two other parts are the potentiometer and the amplifier. Since they are sub-components of the speaker, they were not included in the overall diagram but have their own research section and part selections. Lastly, the audio storage/ SD card and reader have not been included on the chart if the short instrument note files can be saved to the memory of the MCU/CPU, whether through internal or external memory specific to the chip. The project requires 8 notes for each of 5 instruments for a minimum of 40 total files. This was not included despite having its own research section because it may become a sub-component of the CPU section.

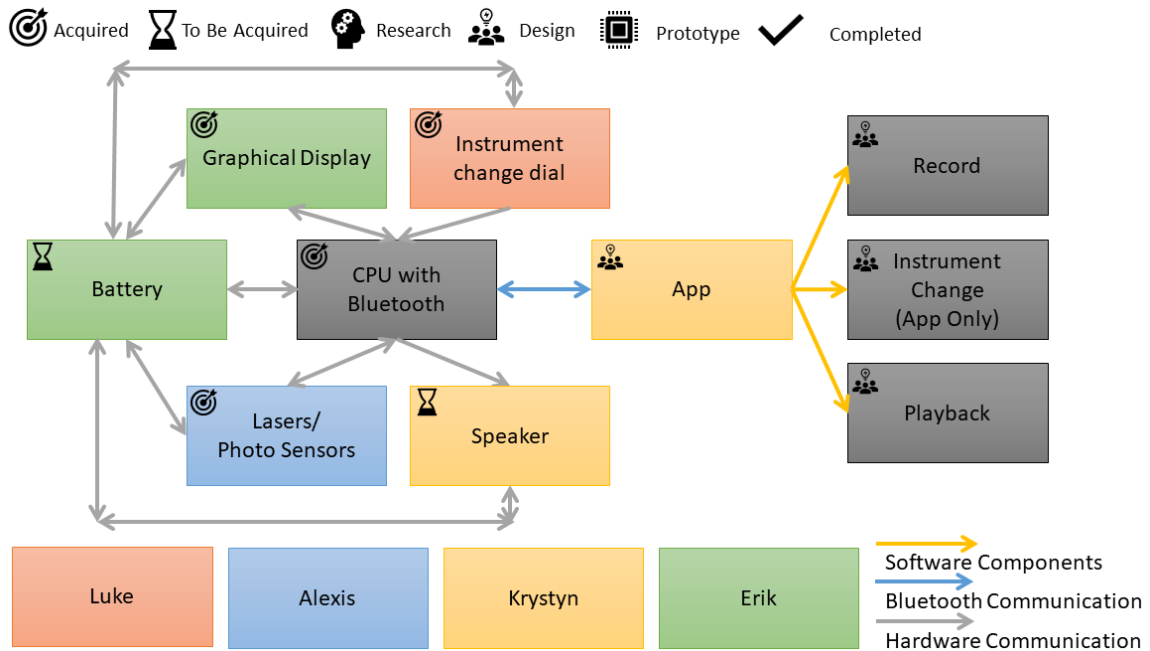

Figure 3 Block Diagram Team Responsibilities

2.6 House of Quality

The house of quality diagram shown in Figure 3 analyzes the strengths of correlation between the engineering requirements and the market requirements of the project. The purpose of this analyzation is to clearly display how each

requirement affects another. For example, the engineering requirement of “Cost” directly affects the project’s ability to satisfy every market requirement. A decrease in the overall cost of the project would likely decrease the ability to satisfy the market requirements of high audio quality, a high level of expected performance, the final product’s battery life, and the overall portability of the device. However, keeping the cost of the project low would likely result in a cheaper final product in the market and therefore apply to a larger range of audience.

The house of quality diagram also helps to determine the order of priority for the team’s engineering requirements when satisfying each of the market requirements. As seen in Figure 4, the market requirement of having high audio quality in the final product is most heavily affected by the engineering requirements of low cost and low design time, and also has some correlation with the data retrieval rate and number of instruments supported in the final product. This means that when satisfying the project’s need to have high quality audio output, the team should prioritize the engineering requirements with the highest impact.

Another way to portray the house of quality diagram is to show the weighted values that the consumer and the engineering team place on their own requirements. That method does not work well with this project, and the team has decided not to use this method of portrayal. This decision was made since most market requirements and engineering requirements have equal value within the scope of the project. To ensure a marketable final product, every market requirement must be met. This means that each market requirement has the same value to the consumer as any other market requirement. The project’s engineering requirements are similar. Shown in the “roof” of the diagram, there is heavy relation between many of the engineering requirements. If one requirement is met or is improved, it affects the quality of another engineering requirement. In the case of the laser instrument project, the general characteristics of the final product like cost, design time, weight, and dimensions all influence each other. Internal characteristics related to the project, such as data retrieval rate and instrument reaction speed, heavily influence each other without placing much influence on the other engineering requirements. This separates the project logically into two requirement categories with roughly the same value to the final product.

The market requirements portrayed in Figure 4 depict the needs of the customer that should be satisfied by the final product. The customer requires the final product to have minimal cost, high quality audio output, high quality performance, reach a large audience, maintain a long battery life, and support a high level of portability. These reflect the need for a lightweight portable instrument applicable and marketable to a wide range of consumers, so all the requirements are a necessity.

The three primary technical requirements have been highlighted for emphasis. “Data Retrieval Rate”, “Instrument Reaction Speed”, and “Number of Instruments Supported” showcase a variety of features and operations of the product. These

include the communication between laser diodes and photo sensors, the interaction with the user, the audio file storage and retrieval, and physical input devices.

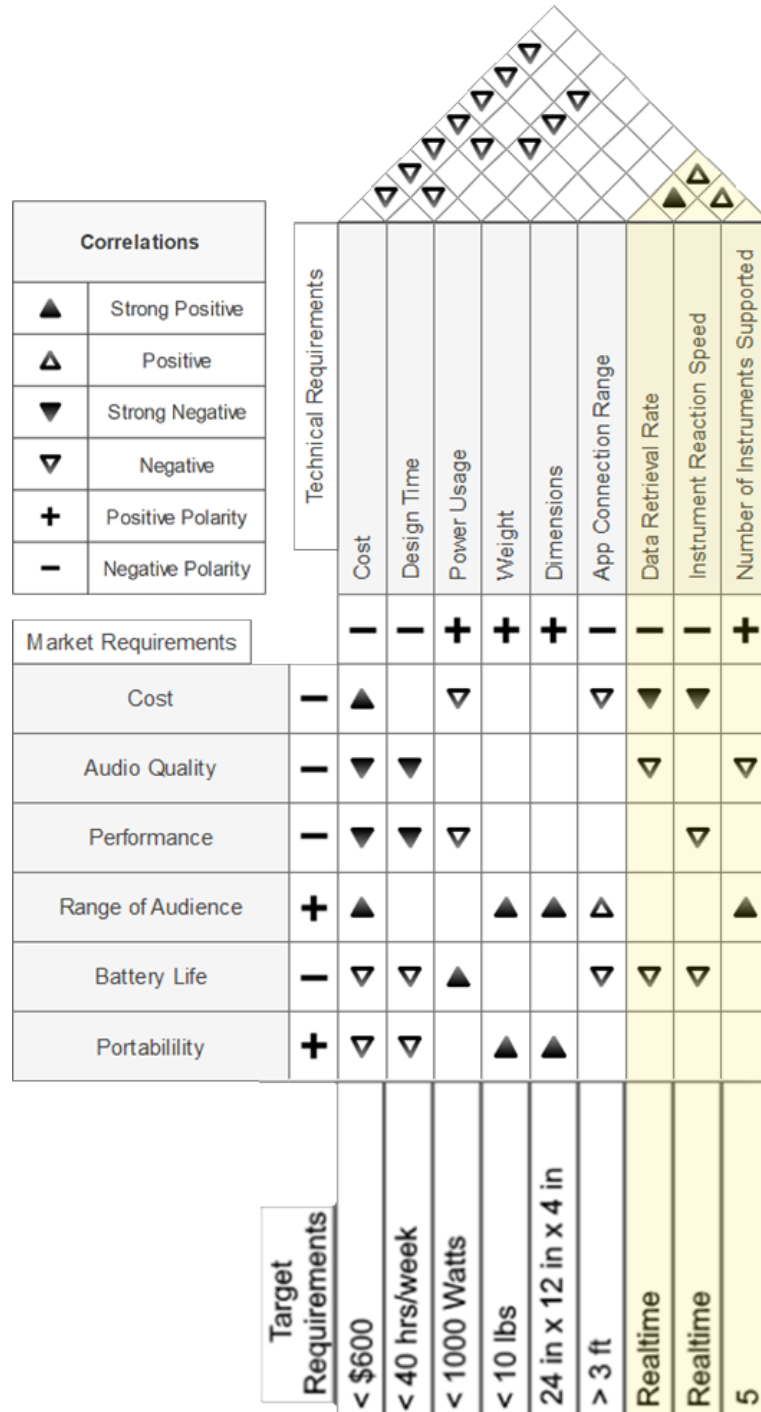

Figure 4 House of Quality Diagram

3 Research and Technical Comparisons

This section outlines the team's research of possible options for each component or material needed to develop the laser instrument project. The research portion for each component highlights important factors to consider during each component's implementation or selection. Aspects such as size, pricing, and availability are a few that must be considered in the part selection process. Following the research sections are technology comparison sections that have side by side comparisons for the parts researched for each component. Based on the researched information and comparisons between other models, a final parts selection section clearly states the chosen part for each component in this section.

3.1 Instrument Frame

The laser instrument should have the same capabilities as a typical electronic keyboard in addition to more innovative features. Users will have the ability to adjust features such as volume via turning knob and change the instrument audio to instruments such as a piano or guitar. An important function is that the device will have connectivity with an app that improves accessibility. This allows users to connect via Bluetooth and customize their instrument to their personal likings. The laser instrument will be more accessible by giving user the option to manually customize the instrument using physical inputs or a mobile application.

Finally, the project will utilize a combination of laser diodes and photo sensors to avoid the inaccuracies of implementing a single photonic laser that breaks a beam into multiple individual beams. Laser diodes can be used with a binary function. By detecting if the light the lasers emit are "broken" or "unbroken", the laser diodes can act as musical keys that are pressed or not respectively. By eliminating this extra step, the accuracy of reading notes increases, and more time can be focused on implementing more audio functionality to the laser instrument.

3.1.1 Research

The frame is the structure that will house all necessary components to allow the laser instrument to be fully functional. The team devised several design concepts based on previously created laser instruments while considering the scope of the project. Key aspects that were significant while drafting these designs include implementing several laser diodes and photo sensors as playable notes, supporting multiple octaves during use of the instrument, and maintaining a portable design. In addition to the team's goals and objectives set for the laser instrument, the frame designs must also adhere to the constraints and requirements outlined in the Project Description of this document. The designs in this section highlight various orientations the laser diodes could be mapped in order to potentially integrate an ultrasonic sensor or alternative device to include multiple octave support for the instrument.

The entire frame must remain hollow to reserve space for wiring and all necessary components. However, for ease of installation, the inside of the frame would benefit from specially designed compartments to fit the selected components outlined in the research section of this document. A specifically sized slot to fit the printed circuit board (PCB) into would reduce further modification of the frame and the board, and it would reduce the risk of damage from abrasion or collision while the instrument is in use. A popular example of this architecture in practice is modern furniture engineering from IKEA, a store that sells its own brand of furniture. Slots and joints force movement in only one direction. Using slots and joints helps to redirect forces in a less destructive manner, extending product lifespan. Incorporating this into this project will reduce long term cost and result in a sturdier final design.

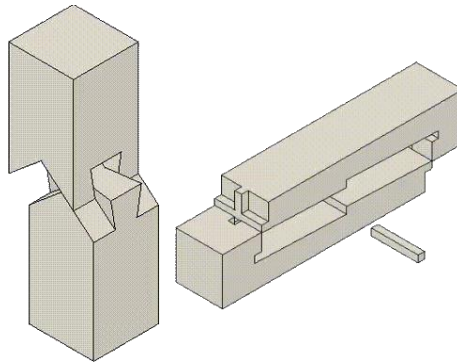

Figure 5 Popular Joint Joining Methods

To mount components inside the frame, prototypes would benefit most from a two-half frame design with latching mechanism to hold the pieces together. This design could also work for the final product. Since the final product is not expected to require further alterations inside the frame, it is more important to focus on a secure fastening of the two halves than on a releasable latch. This can be accomplished with an outer latch for prototypes and an inner latching mechanism for final product. To make the final mechanism more permanent, screws are a simple and commonly used idea that can be applied to the product. However, there are several types of latches that would also be applicable. The deadbolt, spring, and cam latches would all suffice for this project. A crossbar, cabin hook, or toggle latch mechanism would also be suitable alternatives. Nails and screws are commonly used and inexpensive but can be less reusable than other mechanisms to secure the two halves of the frame together. Deadbolt, spring latches, crossbars, and cabin hooks are extremely reliable, but they also require installation within the material of the frame itself and can therefore be costly in labor. They also don't leave a lot of room for modification in the future. The other mechanisms mentioned such as cam and toggle latches require minimal installation but are less reliable because they can be more easily unlatched.

3.1.1.1 Basic Frame Design

The first design in Figure 6 is a basic rectangular shape with space to possibly mount an ultrasonic sensor within the inner portion of the frame. The ultrasonic sensors would be one method of implemented multiple octaves to the laser instrument by detecting the position of a user's hand. Based on where the user breaks the light beam emitted from a laser diode, the instrument would output a corresponding predetermined note value and octave. The laser diodes would be oriented vertically and have light beams emitting straight down towards the bottom of the frame. Having the diodes emit light towards the ground versus upwards would limit the possibility of a diode causing the user eye damage from a laser.

The basic frame design would have limited structural failure, and the parts necessary to manipulate the device, such as power switches and audio dials, would be easily accessible to the user. The design would be playable with one hand without compromising the size of the device. Compare to other designs later in this section, the basic frame design has the least aesthetic appeal but has the potential functionality wise. Overall, this basic design readily complies with most of the team's decided constraints.

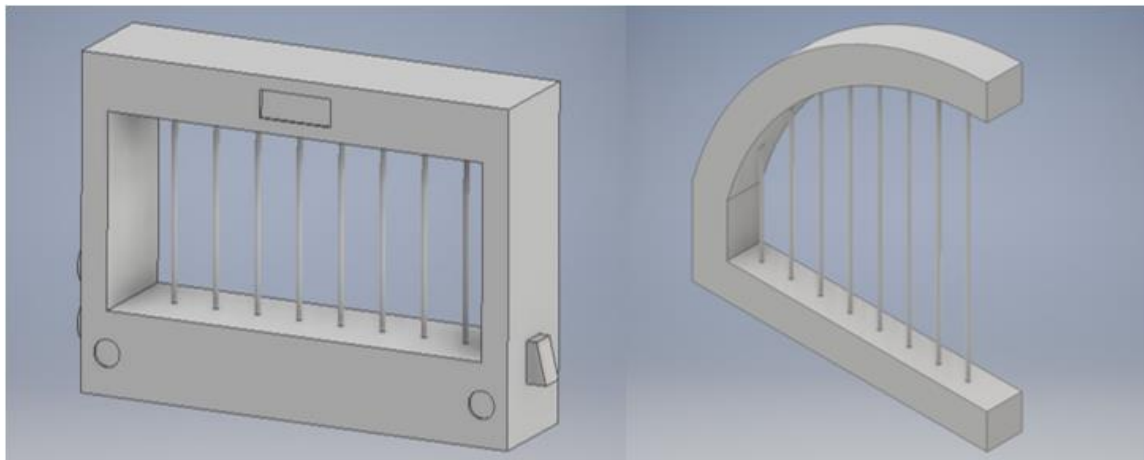

Figure 6 Basic Frame Design and Harp Frame Design

3.1.1.2 Harp Frame Design

The second design features a harp structure that limits or excludes a distance measuring sensor in the design as illustrated in Figure 6. This open-style design was intended to look more like a harp similar to other styles of laser instruments the team encountered while researching pre-existing designs. This design would be more aesthetically pleasing to the user compared to other designs as it would be a familiar shape that users could identify immediately and understand the use of the laser instrument.

The harp design in Figure 6 faces structural integrity complications. The rounded shape of the frame would require more mechanical attention from the team to ensure the upper half of the frame has a strong structural integrity. Complex mechanical features could take away development time from more important focuses such as ensuring electrical functionality. For the photo diode and photo sensor “keys” to work properly, reliable alignment of the diodes and sensors would be crucial to the frame design. Considering constraint C.HS.1, ensuring the alignment of diodes and sensors would not only be important for instrument functionality but to avoid the possibility of a laser diode shining light into a user’s eyes. With these considerations, other frame designs would be more user friendly as well as more practical for project development.

3.1.1.3 Checkered Frame Design

The inspiration for the checkered design frame in Figure 7 generated to implement multiple octaves in the laser instrument. The design would feature 16 laser diodes in comparison to the 8 laser diodes highlighted in previous frame design ideas. With immediate access to 16 laser diodes, the instrument would have two octaves, with 8 notes per octave, readily available for the user to play without requiring more sensors to be incorporated in the instrument’s design.

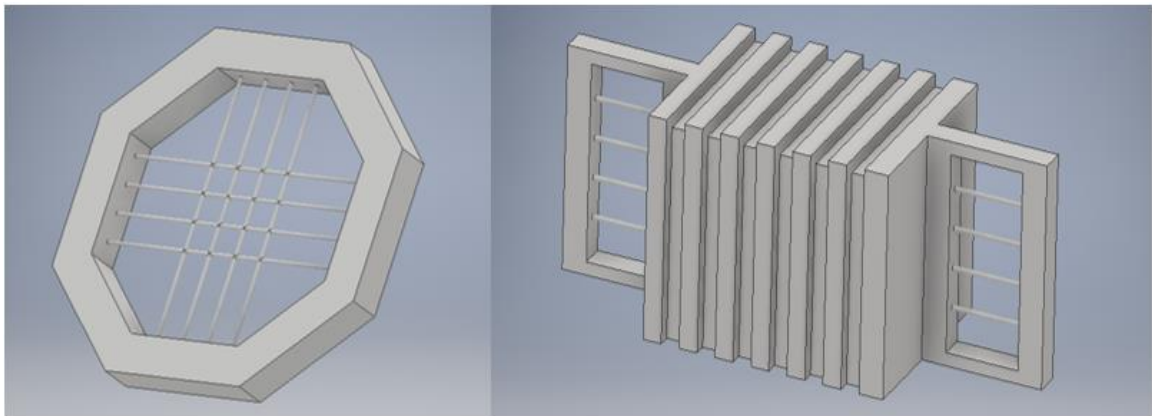

Figure 7 Checkered Frame Design and Accordion Frame Design

Implementing more octaves would appeal to several stretch goals for the project, however the checkered frame design would increase the difficulty of implementing laser diodes. The overlaying beams could disrupt each other and cause complications with determining if the user has broken a light beam. Even if the lasers were staggered, reflected or straying light could result in an abundance of incorrect data. The largest concern with this design would be the orientation of the laser diodes putting the user’s safety at a potential risk. This safety hazard was too large of an issue to ignore as it conflicts with the project’s constraint C.HS.1 which

strives to develop the project without the need of safety gear while utilizing the laser instrument.

3.1.1.4 *Accordion Frame Design*

The fourth design in Figure 7 features an accordion style in which an ultrasonic sensor or distance sensor will produce various octaves based on the distance between the two hand blocks of the instrument. By pulling the two handles apart, the octave would increase smoothly for the player. By contracting the instrument, the octave would then decrease. This design would allow a user to more seamlessly play but this design idea was dropped for a few reasons. The team's largest concern was moving parts and a possibility of design issues in creating the moving parts. The second largest concern was that this design would exclude users unable to play with both hands. This would directly interfere with C.SOC.2.

3.1.1.5 *Frame Material*

The frame's material is an important factor to consider for the frame. While the size and shape of the frame may change, the density of the material used in prototypes and the final product is what will truly affect the portability and usefulness of the frame. The primary characteristics of whichever material used for the frame must include water resistance, heat resistance, electrical resistance, low light reflection and refraction, and low density or weight. The prototype for the project would also benefit from the material being easily modifiable and inexpensive.

The material must be water resistant in order to protect the electrical components from damage from external hazards. Specifically, the component wiring must be protected, so all components prone to water damage are located inside the frame. This means that the material does not need to be completely waterproof, just resistant enough that a complete seal between the two pieces of the frame will prevent any internal water leakage. The most exposed components will be the laser diodes and photo sensors, but the exposed portions of those parts are not susceptible to water damage. Also, the intended use of the laser instrument does not include heavy usage of water or other hazards, so water resistance is a low priority for the frame material. As long as the material does not absorb water, all vital components should remain intact and the final product will operate as intended.

The material must be heat resistant in order to protect the electrical components from damage from the laser diodes, outside hazards, and general internal electrical work. The laser diodes have an upper voltage limit to prevent them from burning out over extended use, so the instrument can expect to experience several localized heat sources during regular operation. This applies to the locations where the laser diodes are producing light and heat, as well as the locations of the photo sensors where the light and heat is directed. The device can also expect regular low sources of heat from general use of all other electrical components. Since all

components are internal and the frame design is hollow, all internal heat sources will be amplified, and the frame material is required to withstand and absorb some of this heat during regular operation. The material must absorb some of the heat to prevent the internal components from overheating, so heat resistance is important in the way that it must be able to absorb a significant amount of heat without compromising structural integrity.

Table 5 Material Comparison

Material	Melt Temp. Range (°C)	Material	Melt Temp. Range (°C)
ABS	190-270	POLYESTER PBT	240-275
ABS/PC ALLOY	245-265	POLYPROPYLENE (COPOLYMER)	200-280
ACETAL	180-210	POLYPROPYLENE (HOMOPOLYMER)	200-280
ACRYLIC	220-250	POLYSTYRENE	170-280
CAB	170-240	POLYSTYRENE (30% GF)	250-290
HDPE	210-270	PVC P	170-190
LDPE	180-240	PVC U	160-210
NYLON 6	230-290	SAN	200-260
NYLON 6 (30% GF)	250-290	SAN (30% GF)	250-270
PEEK	350-390	TPE	260-320

The material must have electrical resistance to avoid injury to the user during regular use of the product. Each of the electrical components located inside the frame has an upper limit of operational voltage that the team will adhere to, but for safety it is important for the frame to be made of a nonconductive material that will not affect the user during regular operation. Having a nonconductive material will also benefit the electrical components because the chance of false connections being made is reduced in a medium that does not carry a current. This would allow the laser diodes and photo sensors to be positioned closer to each other without running an increased risk of misfiring lasers or getting false positive readings.

Since one of the primary operations of the laser instrument is to emit and read lasers, it is important for the material to be nonreflective and nonrefractive to reduce false positive readings from the photo sensors and reduce risk of injury to the user. Using a transparent or reflective material that can refract the light in an unintended direction risks injuring the user. The light can damage the eyes or skin with high intensity light or localized heat, and lasers shining in unintended ways

can quickly cause the instrument to falsely interpret readings from the photo sensors, affecting the user's experience during regular operation.

One of the market requirements of this project is to make the solution portable. In order to do this, an engineering requirement is to keep the weight of the final product to a minimum. The dimensions of the device are not given as a range but as a goal. Since there is goal set of dimensions and the frame design is a set shape, the best way to reduce the weight of the final product is to use a material with a lighter density, while still upholding structural integrity and holding shape under regular consumer use. The frame will account for the majority of the weight of the final product, so the density of the material has the highest impact on this market requirement compared to all other components of the project.

While working with a prototype, the device would benefit from the material being easily modifiable and inexpensive. Expecting to use the same electrical components throughout most or all of the prototypes, the frame will likely undergo several changes before final designs are made and the components are more confidently put in place. The frame is expected to undergo several alterations including cutting, molding, drilling, chiseling, bending, and breaking. They will need to survive simple stress tests to simulate the bounds of intended use by the consumer, and improvements will be made on the spot to reposition laser diodes or other components. For these reasons, several prototype frames will be used, and a lot of material will be bought and used to replace older versions of the frame.

Styrofoam, wood, plastic, and metal are all commonly used building materials for a variety of structures and devices. Each has their vices and virtues with respect to this project. Styrofoam has excellent water and electrical resistance but is highly susceptible to localized heat. It is inexpensive and can be modified easily but is difficult to put back together and typically requires a heavy amount of modification initially depending on the size and shape. Styrofoam is also structurally weaker than the other materials evaluated. Wood absorbs water and deteriorates after extended exposure to liquids, burns easily, carries a current, is more expensive, and requires tools or machinery to modify. Plastic is the most commonly used material for handheld devices, is water and heat resistant, and does not carry a strong current in most cases. It can be more expensive than some other materials based on the plastic being used. Also, different plastics have varying levels of modifiability that would affect their applicability to this project. Metal absorbs heat, is worn down by extended exposure to water, carries a current, reflects light, is expensive, and cannot be easily altered from its original state.

3.1.2 Technology Comparison

The frame design and frame material are the building block of the entire project and must be analyzed thoroughly. For the frame designs, each design is compared to see how well they match up with the project's goals, requirements, and

constraints. The focus for the frame material is something that is durable and can house all the electrical components effectively without hindering their operations.

3.1.2.1 Frame Designs

The previous frame designs are varying models to implement different approaches to design the laser instrument. The frame designs outlined in the Research section each have strengths and weakness ranging from aspects such as usability of the instrument to the engineering complexity involved to develop.

The accordion frame design would be the most difficult to design as an instrument frame. In order to change the octaves with the accordion approach, a user would always have to hold the frame while occasionally compressing and stretching the core of the instrument to allow a sensor to determine distance between the handling pieces. Compared to the basic, harp, and checkered designs that would not require movement to function, the accordion design would require movement from the user to utilize all features of the device. Since the design would also have two handlings each with four laser diode “keys”, the accordion design would also mandate the user use both hands to operate the instrument. Not granting the user the option to operate the laser instrument with one hand or two conflicts with the social constraint C.SOC.2 found in Table 40 and would make the design less appealing to casual music players.

Table 6 Frame Design Comparison

	Basic	Harp	Checkered	Accordion
Hands required to operate	1	1	1	2
Self-standing While Utilizing	Yes	Yes	No	No
Laser diodes always emitting light way from the user’s eyes	Yes	Yes	No	Yes
Minimum keys supported	8	8	8	8

The checkered frame design would present the most challenges from an electrical implementation and design standpoint. The octagon frame would demand at least one wide section to ensure enough space to house all necessary electrical components to operate the laser instrument. The design also would pose an issue with operational integrity of the instrument. The most concerning factor for the checkered frame design would be its complications with the health and safety constraints C.HS.1 outlined in Table 42. The way the laser diodes would need to be oriented in the checkered frame design to operate could compromise the team’s

ability to orient the lasers in a way that would reframe from light being emitted in the direction of a user's eyes.

Based on the characteristic comparisons of the frame designs in Table 6, the harp frame design and the basic frame design would satisfy more of team's goals and objectives without compromising established requirements and constraints for the laser instrument project.

3.1.2.2 *Frame Materials*

A cheap, hardened plastic would be the lightest and most common material for prototyping as it would allow quick and frequent altering and is easily replaceable. As more prototypes are created before the final product, the hardened plastic would not affect the budget goals too much. Also, it is a good enough material to use in the final product because it is durable enough to last for long periods of time after it has been altered and can withstand having several small components mounted to it. Common building metals, while sturdy and reliable, have been determined to be too heavy for the portable design required to meet the specifications of this project. Even hollowed aluminum would raise the weight of the handheld device by a few pounds, which directly conflicts with the requirement to make the instrument as portable as possible.

Table 7 Frame Material Technology Comparison

	Water Resistance	Heat Resistance	Electrical Resistance	Reflectivity / Refractivity
Styrofoam	High	Moderate	High	Low
Wood (Plywood)	Low	Low	Moderate	Low
Plastic (HDPE)	High	Moderate	High	Low
Metal (Aluminum)	Moderate	Moderate	Low	High

In Table 7 and Table 8, the most commonly used materials are compared to determine their worth with respect to the characteristics necessary for this project. The greatest value for a given material for the final product comes from having high water resistance, high heat resistance, high electrical resistance, low reflectivity and refractivity, and low density. The greatest value for a given material for prototype products comes from having high modifiability and low cost. The materials that would have the greatest value for using in the final product are plastic and Styrofoam. There are several different plastics with varying properties that each has its own impact on the requirements it would fulfill for the project. Both materials also have the greatest value for use in any prototype products. Wood and metals, though commonly used, would not provide much benefit if used in this project.

Table 8 Frame Material Technology Comparison (Cont.)

	Density	Modifiability	Cost
Styrofoam	Low	High	\$1.06 / ft ²
Wood (Plywood)	Moderate	Moderate	\$1.12 / ft ²
Plastic (HDPE)	Moderate	Moderate	\$2.00 / ft ²
Metal (Aluminum)	High	Low	\$13.07 / ft ²

3.1.3 Part Selection

In this subsection, the aspects analyzed in Technology Comparisons are used to select the specific material and frame design that will be implemented in the final design of the laser instrument. Durability and functionality were of the top priorities considered when making the final selections.

3.1.3.1 Frame Design

Figure 8 is a prototype illustration of a basic model featuring a rectangular shape that emits laser diodes towards photo resistors. This design was based after models the team had seen but was modified to have a more simplicity and visible user experience. It was intended to have a smaller profile to make it more portable for a user in order to play the device anywhere with minimal to no restrictions.

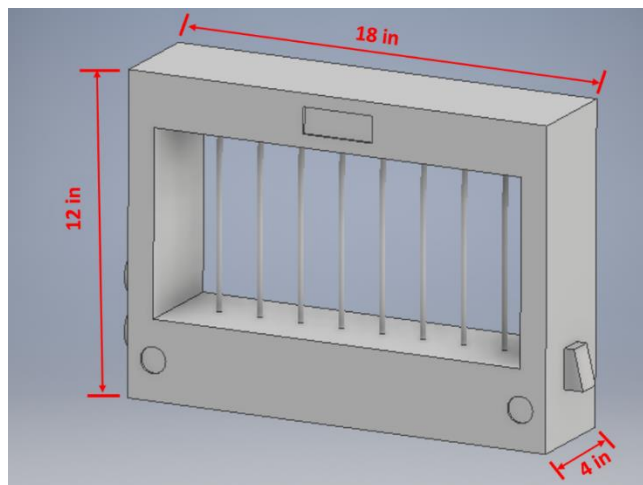

Figure 8 Isometric View of Instrument

In Figure 8, the basics of the project are shown: a compact frame that encompasses a total of 8 different notes that are played by breaking the light

between a laser diode and a photo sensor. The design depicted is meant to have no back wall or preventative surface so the user could see through the device's center. The structure was meant to be no more than a rectangular frame for the sake of being lighter and possibly able to be foldable for more portability. Although not labeled as so on the design, the letters above the "keys" created by the beams of light were intended to be labeled on the frame in some manner, so users know what notes they are playing. It was also an example of the plan to only include the natural accidentals of all notes, and a singular octave as well.

The back and side of the device illustrated Figure 9 features volume-controlled speakers and a dial that would allow changes in the audio output. A variety of different instruments would be chosen by the dial on the side, giving users the ability to customize the output sound of the laser instrument while playing. For the purposes of this project, five different categories of instruments would be selectable for the user to choose. However, many more instruments could be included in the device. The body of the design would include speakers for the user to hear the notes real time while playing the instrument. The speakers would be positioned on the front of the laser instrument to provide the user with a better sound environment.

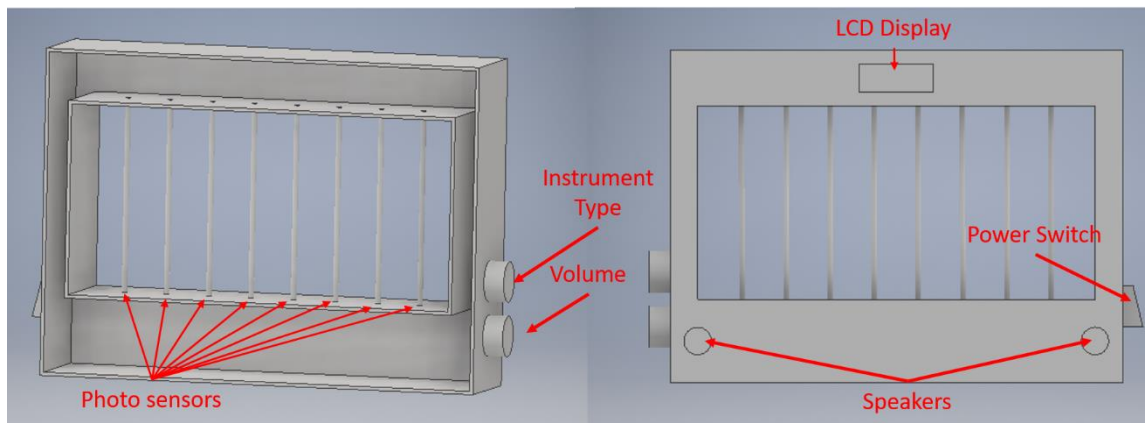

Figure 9 Back and Front Views of Instrument

To keep the user from being exposed to any electronics and potential harm, a removable back panel would be implemented in the basic design frame, and the design would utilize small cantilever snap joints to secure the back panel to the rest of the frame. The back, pictured as the left image in Figure 9, shows the panel that covers the hollowed frame which prevents the user from being exposed to electronics. The back panel would also have an opening in the center like the main component of the frame. This would allow users to play from either side of the device and give the user more liberty during the playing experience. On the top of both shown faces in Figure 10, the small hooks and holes to keep the panel from sliding off are visible. Although not present in previous figures, either cantilever

joints or another method would be employed to keep the back panel from sliding off the device during transportation. With this back panel, the hollow internal structure would have plenty of space for all necessary electrical components without exposing anything that could potentially cause harm to users or to the device itself.

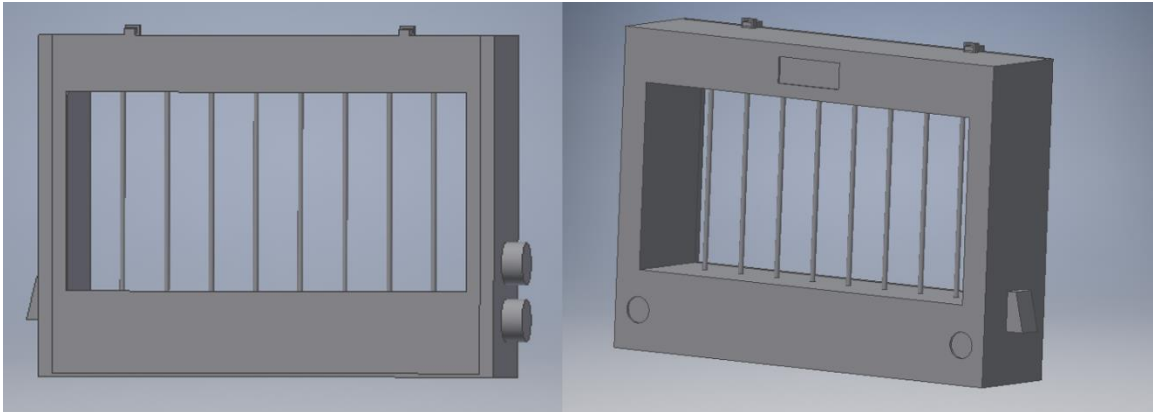

Figure 10 Frame Back and Front with Sliding Back Panel

To mount components inside the frame, prototypes would benefit most from a two-half frame design with latching mechanism to hold the pieces together. This design could also work for the final product, but the final product is not expected to require further alterations inside the frame, so it is more important to focus on a secure fastening of the two halves than on a releasable latch. This can be accomplished with an outer latch for prototypes, and an inner latching mechanism for final product. To make the final latch more permanent, screws are a simple and commonly used idea that can be applied to the product.

3.1.3.2 Frame Material

Wood and metal are not being considered for the frame material for this project. Both of their properties directly conflict with the material requirements for the final product and would increase operational errors and user safety. Both interact poorly with heat, water, and electricity, and they are more expensive and difficult to make changes to. These flaws would increase the risk of operational error and hazards to the user. For the purposes of this project, they would make very poor choices in the final product for testing and consumer usage.

The viable material options for this project, listed in Table 7 and Table 8, include Styrofoam and plastic. Neither material reflect or refracts light, and they are both water resistant and nonconductive. Styrofoam satisfies less requirements than most plastics do and will therefore be used in the initial prototypes. It is the easiest material to modify the size and shape of, and it is inexpensive enough to create

several prototype instruments without heavily affecting the overall cost of the project. Plastic is sturdier and more reliable, but also typically more difficult to alter and more expensive than Styrofoam. For these reasons, plastic should be used in the final product as well as the later stages of prototypes.

Table 9 Polymer Compression

Polymer Name	Min Value (g/cm ³)	Max Value (g/cm ³)
ASA/PVC Blend – Acrylonitrile Styrene Acrylate/Polyvinyl Chloride Blend	1.200	1.200
ABS/PC Blend – Acrylonitrile Butadiene Styrene/Polycarbonate Blend	1.100	1.150

The project includes three stages of materials to be used for the frame. The first stage is using Styrofoam, which will be used for its inexpensiveness and easily modifiable composition. The first several prototypes of the laser instrument will be used to determine a final layout and design of the frame, including the spacing between components, securing mechanism testing, and low-level consumer testing. Once the dimensions and layout of the device has been finalized, the project will enter the second stage of frame materials. At this point, the frame will be made of a comparably inexpensive plastic that is fundamentally weaker, allowing the device to still easily make physical adjustments where needed.

Switching to a plastic will allow device testing to be more like the expected final product and will satisfy more of the material requirements. A popular plastic for this is vinyl. It is more susceptible to abrasion and heat but is reliable enough to apply most frame testing that would still be applicable to the final material. When prototypes are complete and the final product is being made, Lexan is the ideal material. It is a more expensive plastic that is popular in robotics and household devices. It satisfies all material requirements but is more expensive. It has a longer lifespan than vinyl because it is less affected by abrasion and heat, which is why it is the material of choice for the final product for this project. The final material is the material to be tested and evaluated for this section, shown in Section 5.2.1.

3.2 Laser Diodes

For the laser instrument, the team plans on utilizing laser diodes as an innovative implementation of musical instrument keys. Instead of having to press a button to play a musical note as one would do for most standard instruments, the laser instrument would rely on breaking the light beam of a laser diode. When a laser diode is prevented from emitting light onto a photo sensor, the laser instrument would produce a musical note. This process would be synonymous with pressing a key on a standard musical instrument.

3.2.1 Research

The most common laser diodes that would be feasible options for this project are red laser diodes and green laser diodes. These wavelengths of laser diodes were the most available at the time of research and development for the laser instrument project. Each laser diode has its own advantages and disadvantages that must be considered to determine which would best fit the scope of the laser instrument project.

3.2.1.1 Red Laser Diodes

Red laser diodes emit light in the red spectral region with a wavelength ranging from about 625 nm to 700 nm. Hobby level red laser diodes typically come in wavelengths of 635 nm, 650 nm, and 670 nm. Shorter wavelengths overall provide easier visibility to the human eye but can potentially pose more difficulties when it comes to efficient generation of the laser [8].

Compared to their green counterpart, red laser diodes are usually cheaper and more readily available. This will contribute to the affordability aspect of the project outlined in the Project Description. Given that the project also aims to be portable, the red laser diode's lower power consumption would allow for a frame design and power supply component that are not as space consuming or high temperature emitting. The diodes themselves would not demand excessive amounts of space in the frame as well making them an additionally appealing choice. Even though red lasers have a lower visibility to the human eye compared to green lasers, this project does not require the extra visibility that would warrant a green laser to make a significant difference in comparison [9].



*Figure 11 Adafruit (left) and HiLetgo (right) Red Laser Diodes
Permissions in Figure 26 and Figure 27*

The laser instrument project does not require industrial-grade laser diodes, so the red laser diodes researched were hobby level. The two considered were the

Adafruit 5 mW 650 nm Red Laser Diode pictured left in Figure 11 and the HiLetgo 5 V 650 nm 5 mW Red Diode Laser pictured right in Figure 11. The tubing that encases the red laser is the most significant distinguishing factor between the two different versions aside from the cost per unit of each. Both operate with similar voltage and current specifications and emit a laser with a similar dot shape. However, despite the many commonalities in their operation and performance, the Adafruit laser diode has larger tube dimensions [10]. The size of the laser diode tube chosen would directly affect the size of the instrument's frame, so this aspect of the laser diodes' shapes must be considered during the part selection for the laser instrument. Keeping this in mind, a smaller diode would be preferable for this project.

3.2.1.2 Green Laser Diodes

Green lasers emit light in the green spectral region with a wavelength ranging from about 510 nm to 570 nm which would be suitable for several photo sensors to read [11]. Despite red lasers being more common in use than green lasers, green lasers can shine up to four times brighter which would make it easier for users to see exactly which diode, or diodes, they are blocking in ambient light. For the purposes of this project, the laser diodes implemented do not require a far reach in order to have a successful laser instrument. Green laser diodes do not have as many suppliers or demand in comparison to their red counterparts. This in conjunction with the fact that green laser diodes have a higher power consumption and produce more heat make it hard to support mass producing. The higher cost of a green laser diode would also conflict with the affordability aspect of this project [12].



*Figure 12 Digi-Key (left) and Lights88 (right)
Permissions in Figure 29 (Lights pending permissions)*

While researching various green laser diodes for comparisons, there were limited options for hobby level laser diodes. The few laser diodes found that were in the scope of what the laser instrument project requires had higher price points per unit and larger tube dimensions. The Digi-Key VLM-520-28 LPT, pictured left in

Figure 12, has a tube length of 33 mm and diameter of 9 mm. The price point per unit at the time of research was \$34.95 [13]. The most comparable pricings for green laser diodes were found on Amazon that still had more expensive price points when compared to red laser diodes. At the time of research, the Lights88 532nm Green Laser Module Diode, pictured right in Figure 12, had a unit price of \$16.89 [14]. Although the price point was more reasonable compared to the Digi-Key green laser diode, the Lights88 laser diodes had a longer tube length compared to red laser diodes at about 31 nm.

3.2.2 Technology Comparison

Red and green laser diodes each have advantages and disadvantages that would contribute to the goals and requirements of the laser instrument project. Since the laser instrument only requires a laser diode to emit a light beam no more than 2 feet, the distance at which a green laser diode’s performance would supersede a red laser diode’s performance would be beyond what the project would utilize.

Table 10 Laser Diodes Comparison

	HiLetgo	Adafruit	Digi-Key	Lights88
Tube Length	18 mm	31 mm	33 mm	31 mm
Unit Cost	\$0.55	\$5.95	\$34.95	\$16.89
Operating Temperature	-10°C to 40°C (14°F to 104°F)	-10°C to 40°C (14°F to 104°F)	15°C to 30°C (59°F to 86°F)	10°C to 40°C (50°F to 104°F)

The information presented in Table 10 highlights some of the key aspects that impact the project’s goals and objectives as well as the design. The green laser diodes mostly offer a more vibrant light beam that has a better chance of being viewed by the human eye in ambient light in comparison to red laser diodes. This would be an attractive feature for the laser instrument as it would potentially add another layer of visibility to the user while playing notes. However, this potentially nice extra feature that could be incorporated in the design of the laser instrument does not offset the exponentially higher price difference between the red light emitting laser diodes and the green light emitting laser diodes.

With the green laser diodes eliminated as options due to their conflict with maintaining affordability without greatly sacrificing the quality of the project, the HiLetgo and Adafruit red laser diodes are the remaining choices. Although the Adafruit laser diode has a slightly higher unit price compared to the HiLetgo laser diode, the length of the diode tube was more of a concern for the team. A longer tube length would mean the instrument frame would have to overcompensate its dimensions to fix the component and any supporting electrical wiring. This could potentially limit the team’s flexibility later in the design process or negatively impact the portability aspect of the laser instrument.

3.2.3 Part Selection

After reviewing the various options for green laser diode and red laser diodes, the team quickly decided a red laser diode would be the best fit for the project. Of the red laser diodes researched, the HiLetgo 5 V 650 nm 5 mW Red Diode Lasers were chosen for the laser instrument project. The HiLetgo laser diodes satisfies all of the team's goals and requirements for the projects without stepping out of bounds of any established constraints. These laser diodes are a reasonably priced component with compact sizing that would allow more flexibility during the prototyping and testing phases of the project.

3.3 Sensors and Light Detection

For the laser instrument project, a photo sensor would be implemented to determine whether a laser diode's beam is continuous or interrupted. This functionality would be used to determine if the laser instrument project should produce a musical note. Without photo sensors, there would not be a way for the laser instrument to determine if a user has interacted with a laser diode's beam of light.

3.3.1 Research

The types of photo sensors the team considered viable choices for the project were photoresistors, photodiodes, and phototransistors. These are the most common photo sensors used for visible light detection. The most important factors to consider while researching the photo sensors are the wavelengths they receive and any time latencies that could prevent real-time readings.

3.3.1.1 Photoresistors

Photoresistors or light dependent resistors (LDR) would be applicable to this project since they measure light intensity. Using these light controlled resistors would simplify the analyzation of detected light data in this project since they have an inverted relationship with light intensity; a higher light intensity from a laser diode would decrease the LDR's resistance whereas lower light intensity would increase the resistance. Since LDR readings can reach up to 1 M Ω in dark environments and can drop to a couple of ohms in high intensity lighting, this range would be more than enough to satisfy the purposes of the project. Despite their cheap cost and bi-directional functionality, environmental safety concerns remain one of the largest drawbacks of implementing photoresistors in the laser instrument. Some countries have banned any LDRs composed of cadmium or lead which would compromise environmental standards for the project and possibly affect accessibility in countries where photoresistors are not sold [15]. Compared to photodiodes and phototransistors, LDRs have the lowest sensitivity levels which may cause issues when determining laser diode light versus ambient light.

Fluctuating temperatures can also cause LDRs to vary resistance level even when reading a constant light intensity, making precise light intensity measurements less reliable with LDRs.

The time latency for LDR makes it impractical to use for detecting rapid light fluctuations. When the LDR is exposed to light after total darkness, a time latency averaging 10 ms occurs prior to the resistance diminishing completely. When the alternative situation transpires, the total elimination of light from the LDR, the latency time can reach up to 1 second before the resistance increases to its maximum value. This time latency issue could be problematic if a user is rapidly switching between different “notes”, however it should not be an obvious discrepancy while utilize the laser instrument. Extrinsic LDRs are better suited to detect longer light wavelengths making them ideal for infrared (IR). However, LDR’s heat buildup can manipulate the resistance of the device as a result of thermal effects [16].

The main goals and requirements for the project that photoresistors would impact include cost, circuit integration complications, marketability, and environmental impact. One major advantage that photoresistors would offer to the project is their low cost since they are mass produced and readily available. In addition, photoresistors are easy photo sensors to analyze in project circuitry since they measure changes in light intensity with resistance. The easy implementation would minimize electrical complications for the project and would allot more time to the team to tackle more stretch goals.

3.3.1.2 Photodiodes

A photodiode would be another option of a photo sensor that could be implemented in the laser instrument. Instead of using resistance to determine light intensity changes, a photodiode would use a semiconductor device to convert light energy into electrical current in order to determine if a user has blocked a laser diode. Being that photodiodes and phototransistors are similar photo sensors, the differences between their operations and functionalities are important to note. Photodiodes generally have a marginally faster output response time but lower sensitivity when compared to phototransistors [17]. In terms of the laser instrument project, the fast response time would be a valuable characteristic to have from its chosen photo sensor. Considering that the laser instrument should be able to operate in a variety of room lights, whether the environment has ambient lighting or no lightning at all, the sensitivity of the chosen photosensor could affect the performance of the laser instrument.

The construction of a photodiode usually features a transparent or clear lens for their outer casing in order to focus light onto a PN junction. This method helps the increase the sensitivity and provide a better reading. The junction is better suited for longer wavelengths within the red and IR ranges versus other wavelengths in the visible light spectrum [18]. If red laser diodes and photodiodes were chosen for

implementation in the laser instrument project, the photodiodes suitability with red wavelengths would support the component pairing. Selection of a photodiode would also limit the team's options in terms of what wavelengths the laser instrument project would support. Narrowing options to only one component type is often a bad engineering practice if it can be avoided, and this limitation should be thoroughly considered before selection.

Potential candidates for photodiodes to implement in the project researched were filtered to have peak wavelengths in a range of 500 nm to 700 nm and to have a minimum of 20 units in stock to ensure enough parts for testing or account for any faulty parts. In addition, the unit cost per photodiode should remain at a reasonable amount to maintain affordability of the laser instrument. This filter provided a finite list of options which did not always fit the criteria needed for the project. Thus, other peak wavelengths were considered. At the minimum, the spectral sensitivity range of the photodiodes had to be inclusive of the 520 nm to 670 nm range as most green laser diodes and red laser diodes wavelengths would be included in that range.



*Figure 13 SD057-11-21-011 (left) and PDB-C142 (right)
Permissions in Figure 29*

Several photodiodes with peak wavelengths around 900 nm were discarded as options during the part research process as they did not include a receiving wavelength range that accommodated green and red laser diodes. Of the suitable photodiodes that met most of the project's requirements, many components such as the Digi-Key SD057-11-21-011 pictured left in Figure 13 had high unit prices at the time of research [19]. This photodiode manufactured by Advanced Photonix has a peak wavelength of 660 nm which falls within the desired wavelength ranges preferred for the laser instrument project. The project would require a minimum of eight photodiodes to satisfy the goals and requirements the team set for the project, so that would make the \$50.56 unit price for these photodiodes unappealing in comparison to Advanced Photonix's PDB-C142 photodiode pictured right in Figure 13. The PDB-C142 also has a peak wavelength of 660 nm, but its lower unit cost of \$2.98 per photodiode outshines the consideration of the alternative option [20].

3.3.1.3 Phototransistors

Phototransistors is essentially a photodiode with amplification. Phototransistors feature NPN transistors to receive light levels to determine the current that flows between an emitter and collector in a PN-junction. Their ease of use and sensitivity to light makes it applicable for various uses: lighting control, card readers, security systems, light/IR counting systems. For the purposes of this project, if a phototransistor receives normal ambient light or dark current from an unlit space, small current readings will be produced. When a high concentration of light emits on a phototransistor, the current is amplified which helps to determine if a photo diode is emitting light on the sensor or not. Unlike a photodiode, phototransistors do not require an additional component to amplify the current output [18].

Phototransistors can be based around NPN and PNP transistors. Since phototransistors are optimized for photosensitive readings, they have larger base and collectors than a standard transistor [21]. Based on the amount of light shining on the base (B) of the phototransistor and the amount of current that is produced from the current passed into the collector (C) terminal and out of the emitter (E) terminal, the amplified current can be used to measure how much light the transistor is receiving. This project does not need an exact measurement of light read by the component, but the brightness of the light entering the phototransistor's base can be determined from the input current and amplified output current.



*Figure 14 HiLetgo, SGT516GK, and SFH 3310 Phototransistors
Permissions in Figure 27 and Figure 28 (permissions pending for SFH)*

The HiLetgo Light Sensitive Phototransistors pictured on the left in Figure 14 were the initial photo sensors considered for the project [22]. These phototransistors receive a range of wavelengths from 400 nm to 1000 nm that would detect any of the light emitting diodes researched for the laser instrument, and previous buyers of this phototransistor mentioned they operated well with red laser diodes. With decent functionality and a unity price of \$0.25, the HiLetgo phototransistors would be viable options for this project.

The SGT516GK phototransistor manufactured by Shine Gold Electronics and pictured in the center of Figure 14 accommodates a similar range of wavelengths from 400 nm to 1100 nm with a peak sensitivity at 880 nm [23]. As mentioned in the photodiode research section, the preferred peak sensitivity would fall in the range of 520 nm to 670 nm to increase the photo sensor's accuracy. The most noticeable difference between the HiLetgo phototransistors and SGT516GK phototransistor is the shape of the diode head.

The third phototransistor researched was the SHF 3310 manufactured by OSRAM Opto Semiconductors and pictured on the right in Figure 14. Like the SGT516GK phototransistor, the SHF 3310 has a flat diode head. In contrast, the SHF 3310 has a lower receiving range of 350 nm to 970 nm with a shorter peak wavelength of 570 nm. Despite being priced at a slightly higher \$0.88 unit price, the SHF 3310 would still be a feasible option for the laser instrument project [24].

3.3.1.4 Ultrasonic Sensors

Since ultrasonic sensors utilize sound waves to calculate distance from objects, they could be a viable addition to the laser instrument. The sound waves should not interfere with the laser diodes' beams of light or affect the readings of photo sensors. The complication with adapting an ultrasonic sensor to perform various octaves with the laser instrument comes from incorrect sensor placement due to the placement of the sensor.

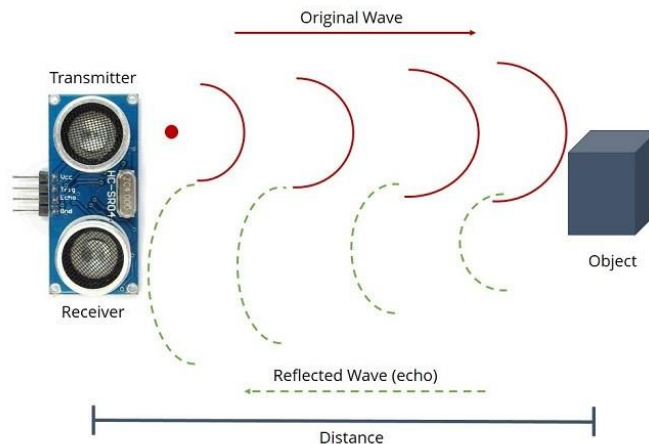

Figure 15 Ultrasonic Sensor Diagram

It is possible for ultrasonic sensors to not detect an object due to shapes or positionings that cause reflected sound waves to be deflected away from the sensor. Small objects and sound absorbing surfaces like cloth and carpeting may not even produce a reflected wave at all. Absorption of the sound waves should not be applicable to this project since it will not be using those absorbing types of materials. The diagram in Figure 15 illustrates the basics on how a HC-SR04

ultrasonic sensor operates. The object in the diagram would be a user hand, and the transmitter (trigger pin) that produces the original sound wave would bounce off of a user's hand. Then the receiver (echo pin) would read the reflected sound wave. Based on the time it took to return the sound wave and the predetermined distance ranges the team would associate to a specific octave, the instrument would be able to produce several different octaves of notes solely based on how far a user's hand is from the ultrasonic sensor [25].

3.3.2 Technology Comparison

The team plans to have a set of eight of the chosen photo light sensors placed at the bottom of the instrument frame which will correspond to eight laser diodes. Each photo sensor would receive light emitted from its corresponding laser diode component. When a photo sensor detects light emitting from a laser diode, the instrument should produce no sound. A photo sensor detecting a laser diode's light beam would be equivalent to a piano key not being pressed.

Immediately after a user interrupts a laser diode beam from emitting a continuous light to a photo sensor, the photo sensor should noticeably change its output to signify to the laser instrument that a note needs to be played. This would be the equivalent to a piano's key being pressed. This time dependent action to reduce delay between a photo sensor's detection of a user's hand and the correlating output of a musical note requires attention to be put on aspects such as the response time of a photo sensor and any time latency uncertainties. The team decided to reject further consideration for photoresistors as a result of their environmental complications which not only negatively impact the environment but compromises the project's goal to pertain to as many markets as possible.

Table 11 Photodiodes Comparison

	SD057-11-21-011	PDB-C142
Unit Cost (USD)	\$50.56	\$2.98
Receive Range (nm)	350 - 1100	400 - 1100
Peak Wavelength (nm)	660	660
Diode Shape	Flat-head	Round
RoHS	✓	✓
Response Time (ns)	13	50
Viewing Angle (degrees)	51	40
Diode Head Size (mm)	5.46 x 5.46	5.6 x 5.6

The remaining photo sensors, photodiodes and phototransistors, have varying advantages and disadvantages. Since red laser diodes and green laser diodes are

the considered light sources for this project, it should be highlighted that the wavelength of red light is 620 nm to 750 nm and the wavelength of green light is 495 nm to 570 nm. Photodiodes have a larger detection range of 200 nm to 2000 nm but require an amplifier to operate. Phototransistors have a slightly narrower range of 400 nm to 1000 nm and would be preferable since they do not require additional components like an amplifier to function for this project.

The team still reviewed various photodiodes to ensure any further reasoning that phototransistors should be the chosen photo sensor. The photodiodes listed in Table 11 were selected to represent most photodiodes found during the research process. The Advanced Photonix's SD057-11-21-011 photodiode met several criteria that would make it a suitable option for this project's laser instrument. Its peak wavelength was in the desirable range of 520 nm to 670 nm, its response time latency was low as a result of its 13 ns response time, and its size allowed for a decent viewing angle. The Advanced Photonix's PDB-C142 photodiode also highlighted in Table 11 featured the same peak wavelength at 660 nm but had a slightly longer response time of 50 ns in comparison to the SD057-11-21-011 photodiode. However, when compared to \$50.56 per unit, the PDB-C142 photodiode appears as the better alternative without sacrificing quality between the two represented photodiodes.

The HiLetgo phototransistors, SGT5516GK phototransistors, and SHF 3310 phototransistors were selected as affordable and functional photo sensors for the project. As highlighted Table 12, all have low unit costs and similar wavelength receiving ranges that would allow them to detect a 532 nm green laser diode or 650 nm red laser diode. The most important difference to note between each is the size and shape of the diode heads. The SGT5516GK and SFH 3310 would be better suited for the project given their flat head design and larger receiving angle of light. Based on basic component testing, the team confirmed the SGT5516GK and SFH 3310 were able to detect the HiLetgo's red laser diode beam with greater accuracy.

It was also noted that the SGT5516GK phototransistors had greater differences in voltage readings between ambient room lighting and the light received by the laser diodes. Ambient room lighting averaged about 0.35 mV whereas readings from the laser diode ranged from 6 mV to over 400 mV. This discrepancy is perceived to be a result of human error while aiming the laser diode at the phototransistors and a possible combination of an environment in which the team could not control all factors of the ambient light in the room. However, the SFH 3310 had an ambient light reading averaging 0.073 mV and laser diode readings ranging from about 1 mV to 10 mV. Human error and control factors during testing may have contributed to the small range of values for these sets of tests as well. However, the SFH 3310 had a much smaller and more finite range compared to the SGT5516GK leaving the team to believe they are less sensitive to light fluctuations.

Table 12 Phototransistors Comparison

	HiLetgo	SGT5516GK	SFH 3310
Unit Cost (USD)	\$0.25	\$0.21	\$0.88
Receive Range (nm)	400 - 1000	400 - 1100	350 - 970
Peak Wavelength (nm)	660	880	570
Diode Shape	Round	Flat-head	Flat-head
Diode Head Size (mm)	5 x 5	4.80 x 5.80	4 x 4

The ultrasonic sensor would ideally be implemented as an innovative functionally to produce multiple octaves while playing the instrument. Available space in the inner portion of the instrument frame would dictate whether an ultrasonic sensor would have a preferable amount of operating room or else a cramped operating area would promote inaccurate readings. Ultrasonic sensors are also limited to a measuring window of about 30 degrees. This would introduce the consideration of utilizing multiple ultrasonic sensor based on the chosen frame design of the instrument.

3.3.3 Part Selection

Given that both photodiodes and phototransistors have options with generally low unit costs and would be able to detect the green or red laser diodes considered for the project without much difficulty, the ability for phototransistors to be incorporated in the project's circuitry without additional components would be a desirable characteristic. For that, the team made the decision to focus on integrating a phototransistor as the chosen photo sensor for this project.

After some testing with the HiLetgo's phototransistors, the small receiving angle of a diode's emitting light and the small surface area of the HiLetgo phototransistor's diode head left a small detection window. A larger detection window for the implemented photo sensor would be more beneficial to the project as it would reduce the chances of the phototransistors producing incorrect readings. The flat-head diode shape listed in Table 12 for the SGT5516GK phototransistor and SFH 3310 phototransistor would provide a larger receiving angle and allow for more room for diode light detection. During the minor testing, a very specific position was required for the HiLetgo phototransistor to fully detect the red laser diode's emitting light beam, so a flatter head and slightly larger diode head size would make the SGT5516GK or the SFH 3310 phototransistors the preferable design. Despite the larger output voltage range for the SGT5516GK phototransistor, the team will try first implementations of the laser diode using the SFH 3310 phototransistors given their more consistent output values.

Previously designed laser instruments that utilized sensors like ultrasonic sensors for octave changes were typically implemented in frameless laser instruments. Framed laser instruments of related work either did not include an octave altering ability in the laser instrument or instead incorporated a simple set of buttons to shift between a preset number of octaves, often a set of 3 different octaves were provided to alternate between. To account for the sensing range of an ultrasonic sensor two sensor would need to be embedded in the frame of the instrument with the transmitter and receiver side facing downward towards where a user would interact with the light emitting laser diodes.

3.4 Physical Input

User input is directly related to the design of the printed circuit board, the size and shape of the frame, and the intended functions of the instrument. Ultimately the most important features for the instrument are to change the volume of the device and the ability to alter which instrument the audio is simulating. Along with these two different, distinct types of input, a switch or some type of input will be needed to turn the device on and off.

To accomplish this, a potentiometer will be used to control the volume of the device, a rotary encoder will be used for instrument selection, and a switch will be used to turn the device on and off.

3.4.1 Research

In the following section, the research for the rotary encoder, the potentiometer and the on/off switch are explored. The rotary encoder, for instrument selection, will need to be able to satisfy requirement R.P.3. The on/off switch will need to satisfy requirement R.P.5 for turning the device on and off. The potentiometer doesn't have any specific requirements or constraints for the project but will be needed for the user's ease of use.

3.4.1.1 Rotary Encoder

Rotary encoders are small devices that use rotational movement and an internal clock to generate an electrical signal. As the knob on the device is turned, a signal is generated when the pins on the inside between the knob and the disk underneath come into contact. To generate a signal to say which way the dial has been turned, the signal from the pins is generated alongside an internal clock within the small module. When the pin signal is offset from the clock, then the knob is being turned. When the pin signal is ahead of the clock, there's a clockwise rotation happening on the encoder. When the pin signal is 90 degrees out of phase behind the clock, then the knob is being turned counterclockwise [26]. This is shown in Figure 16 to explain how the signal is read.

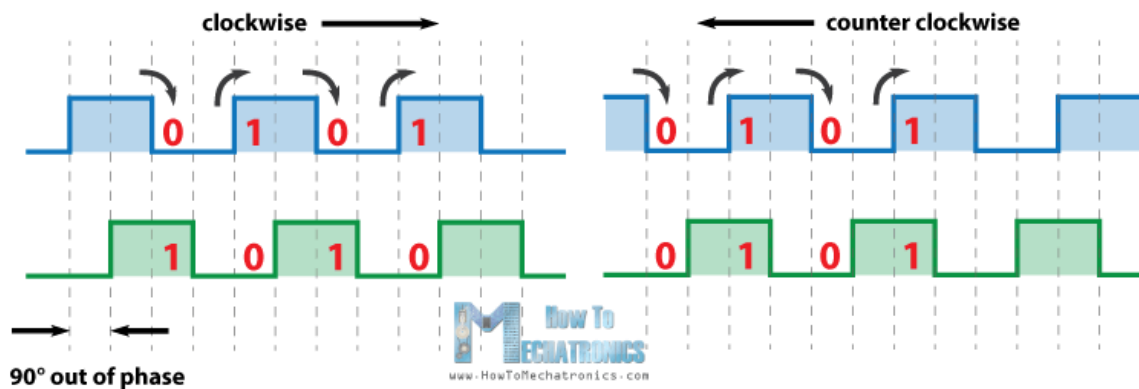

Figure 16 Rotary Encoder Signal Explanation [26]

For use in the project, the rotary encoder will be used in switching between the possible instruments stored on the device. Changing the knob in either direction will go through a looped list of the instruments.

Rotary encoders often have a total of 5 pins, one for the signal generated by the clockwise and counterclockwise direction of the knob being turned, one for the clock, one for the voltage source, one for the ground, and one for a button that is part of the rotary encoder. At this moment in time, there is no planned use for the button on the rotary encoder, but it could be used later in time. A possible use for the button would be the user's selection of the instrument, instead of simply leaving the encoder's dial on an instrument, to signal to the processor what instrument was chosen by the user. This option might give the project more simplicity for the software.

There are three-pin rotary encoders, a ground pin and two pins that are connected to provide a signal of what direction the encoder is being rotated in. It doesn't include the power or button pins like the five-pin encoder does. This affects the overall cost of the three-pin encoder, making it cheaper than the five-pin counterpart.

3.4.1.2 Potentiometer

As the main form of output on the device will be the audio, the chosen method to control the audio output will be using a rotary potentiometer. Volume control is a common use of rotary potentiometers, as the dial changes the resistance, either linearly or logarithmically [18]. Potentiometers typically have three lugs and are passive and don't require input voltage [18]. Common for audio use are ones with about 300 degrees of rotation, 10 kΩ resistance and change linearly. Dual unit potentiometers exist, able to take in two different types of input and affect its output. For the context of this specific project, audio will not need to be split into a left and

right side and can be one singular audio stream, thus only needing the cheaper of the two varieties.

3.4.1.3 On/Off Switch

In a device in which a specification is portability and being powered from a battery, an import component will be an on/off switch located on the outside of the device to conserve battery life while the device is being transported. Rocker switches are currently being explored as potential options for the project based off the size of the project and what other devices will be needed. What turns off the device will need to also be something that tells the device to shut down, not turn off everything itself, so that files and communications are not interrupted or corrupted. Options that are being considered include creating a secondary circuit to control the on/off status of the microcontroller using MOSFETs to control the logic of the circuit. Furthering the importance of preserving battery life, the rocker switches being considered are ones that don't contain lights or indicators. The team can choose to place any extra LEDs to show the power is on if it is decided to be important.

3.4.2 Technology Comparison

The next section explores the decisions made for what parts to purchase for the rotary encoder, the potentiometer, and the on/off switch. The research from the previous section led the group in the process for determining which parts to buy for the project.

3.4.2.1 Rotary Encoder

For the first comparison, a three-pin encoder, Bourns PEC16-4220F-S0024, is set against a five-pin encoder, Bourns PEC11L-4125F-S0020, in Table 13. Using a three-pin encoder wouldn't be conducive if the need to expand were to arise.

Table 13 Bourns Rotary Encoder: Three-Pin vs Five-Pin

	Bourns Three-Pin	Bourns Five-Pin
Cost	\$1.05 each	\$1.39 each
Pins to chip	2	2-3
RoHS	✓	✓
Button	No button	Button
Knob Included	No	No

Although the cost is an incredibly important factor in the determination of parts, the benefit of using a 3-pin encoder would only be that of a marginally lower cost, as per costs found from TTI. A five-pin encoder would give the group the option to

later include a button if the need or use of one arises. If a button isn't necessary, the button pin simply isn't connected to anything. RoHS certified options are widely offered as there aren't any parts specific to this component that are necessary to use non-RoHS compliant materials.

In Table 14 two different options for five-pin encoders are examined. The Bourns five-pin, PEC11L-4125F-S0020, is an active and available part, with pricing from TTI. The Adafruit 337 package, sold by Mouser, is more than just the encoder because it comes with hardware and a small knob that will fit the specific encoder. The Adafruit package itself, according to the adafruit.com website, is nothing more than a Bourns rotary encoder, hardware that will fit the encoder, and a small-profile knob that will fit nicely on the encoder itself. Although purchasing all these separately would ultimately lead to a much lower cost, purchasing the whole set was much more convenient for this project. This was due to having to verify that the hardware and the knob would correctly fit the encoder that would be purchased. More so, the group would have to make sure that all these parts were also RoHS certified.

Table 14 Rotary Encoder: Bourns vs Adafruit Package

	Bourns Five-Pin	Adafruit Five-Pin
Cost	\$1.39 each	\$4.50 each
Pins to chip	2-3	2-3
RoHS	✓	✓
Button	Button	Button
Knob Included	No	Yes

3.4.2.2 Potentiometer

A few different options are present with rotational potentiometers, primarily regarding the style of the shaft and the resistance tolerance. Typically, the cheaper potentiometers have a much higher tolerance, which can affect its ability, or possibly its inability, to control sound. Although in a prototype device, a higher tolerance and lower quality device might suffice. The team can mitigate any irregularities in the volume control by changing the amplifier circuit. In a full scale-production, parts with high tolerances could ruin a project.

A cost comparison in Table 15 compares the technical specifications of AVX 601030 and Alps RK09K1130AH1, both with pricing from Mouser. As seen in the comparison, the extremely low-profile and incredibly cheap AVX potentiometer is a new product but isn't RoHS, doesn't have a shaft of any sort and has a very high tolerance. Being a quarter of the price of the Alps potentiometer is the only specification that this product meets.

Table 15 Potentiometers: AVX vs Alps

	AVX Potentiometer	Alps Potentiometer
Cost	\$0.22 each	\$0.84 each
Resistance	10kOhm	10kOhm
RoHS	No	✓
Tolerance	30%	20%
Shaft Built In	No	Yes
Shaft Variances	No	Yes

Considering a similar potentiometer to the Alp RK09K1130AH1, the TT Electronics P120PK-Y25BR10K is compared to the Alps part used in testing in Table 16. The TT Electronics part appears to far outperform the Alps potentiometer at only approximately 3/4ths of the cost per Mouser for both parts. The TT potentiometer has varied shaft options like the Alps, meaning if the design would do better with horizontally built potentiometers, then the similar part could be purchased with no change in functionality. There several variances with both parts for the shaft besides the horizontal or vertical option of placement. Shaft length, the type of shaft, where the shaft starts and how it is textured are options for both product lines of these parts.

Table 16 Potentiometers: TT Electronics vs Alps

	TT Electronics Potentiometer	Alps Potentiometer
Cost	\$0.59 each	\$0.84 each
Resistance	10kOhm	10kOhm
RoHS	✓	✓
Tolerance	20%	20%
Shaft Built In	Yes	Yes
Shaft Variances	Yes	Yes
Rotational Life	100,000 cycles	5,000 cycles
Rotational Torque	0.5-1.25 oz-in	0.14-1.13 oz-in

The TT Electronics part is even offered with knurled knobs for better grip on an outside dial placed over the potentiometer. The TT Electronics part also has a slightly harder to turn knob, giving more volume control to users to slightly increase or decrease volume. The issue with both potentiometers, however, is that they come with no complimenting hardware or knobs, all of which are necessary for

later steps of the prototype. These will need to be found based on the dimensions of the chosen part. The Alps part does have one large advantage over the TT Electronics potentiometer: the base. The Alps based where the actual resistance occurs is much smaller in size and is squarer in shape. This would result in easier placement of the Alps part compared to the bulkier and round TT Electronics part.

3.4.2.3 On/Off Switch

A rocker-type switch was decided to be a better type of style for the project. Although an extensive bit more work will need to go into the circuit that keeps the microprocessor on until it has completed its work, the on/off switch will be an external component that will be directly seen by the user and is important in overall frame construction. Thusly, the two following rocker-type switches, CW Industries GRS-4011B-0014 and E-Switch RD151C112F, are compared below in Table 17 using prices from Mouser.

The depth in size refers to the distance between the mounting plate and the end of the terminals. Although both switches are rated for much higher voltages and current than will be needed for a project intended to be battery operated, they will more than suffice for the current devices needs. Neither of the compared rocker switches have illuminated switches, giving the team the ability to decide how power is displayed. Although the CW Industries part costs 3/4th of the E-Switch item, it is much wider and isn't labeled. In making this part fit design constraints, having a thinner switch will look better and fit better within the frame. Having the labelling will also be more user-friendly, alerting users to which side of the rocker is on and off for the switch.

Table 17 Rocker Switches: CW Industries vs E-Switch

	CW Industries	E-Switch
Cost	\$0.63 each	\$0.81 each
Illuminated	No	No
RoHS	✓	✓
Max Voltage	125 VAC	125 VAC
Max Current	13 Amps	16 Amps
Size (WxLxD)	.59x.825x.78 inches	.378x.827x.894 inches
Labeled	No	Yes

3.4.3 Part Selection

In this next section, the decisions for purchases are explained for each part selected for the project. The team believes that these chosen parts will be able to

satisfy the requirements decided by the team and contribute to a fully functional laser instrument.

3.4.3.1 Rotary Encoder

For the first trial runs of this project, the Adafruit 377 product was selected for the options that came with the package that included the encoder. The package came with hardware, a washer and a nut, and a knob that fit the selected product. Instead of needing to find all the included products as singular, matching parts that fit all the teams decided specifications, the products and their data was included in the slightly more costly package.

3.4.3.2 Potentiometer

As of this moment in time, despite the TT Electronics part used in the comparison in Table 16 clearly outperforming the Alps potentiometer option, the Alps part was the one purchased most recently for testing. If this part shows obvious signs of wear during testing, is too easy to turn, or appears to be more than 20% out of range of the 10 k Ω variance, then the TT Electronics part will immediately be purchased to begin testing with.

3.4.3.3 On/Off Switch

With a smaller profile, a higher current rating, a labeled rocker and a non-illuminated rocker, the E-Switch part RD151C112F was chosen for the first steps of the design. This part will look more user friendly in the final design, is relatively inexpensive, and will be easy in implement in the testing phase of the prototype. However, if this part will not work for any reason, other types of switches will be explored, but keeping the idea of a slim item with labels to alert the user to when the device has been switched off or on and no illumination to keep down the current draw on the overall device.

3.5 Display

The laser instrument will incorporate a display of some sort in order to aid users while playing notes. The main function of the display is to allow users to visually see the notes they are playing. This will promote the instrument's ease of use. If there are eight notes for every octave, the light crystal display (LCD) should display the layout of each type of note that will be played. The display will provide the instrument with a means to learn the instrument easier and allow larger audiences to adapt to the instrument. While choosing a display, a display with a simple design and ease of use would be preferable. This is because the display will have a straightforward and simplistic function; therefore, an advanced display would be too much for this use case.

3.5.1 Research

The project demands that the device contains a graphical display according to the project requirements. There are a multitude of graphical displays that be chosen for this project; however, it must uphold the requirements of the project. Given the requirements, there are a few options to choose from. The major characteristics that should be sought after are cost and size. The project would benefit from a decent size that is easily visible, but also not too big. Of course, the cheaper the display, the better. Some candidates for a viable graphical display are an array of seven-segment displays, electronic ink, and a light crystal display.

3.5.1.1 Seven-Segment Display

The seven-segment display has a quite simple design with typically ten pins controlling each segment of the seven-segment display, a decimal point pin, and two COM pins for common cathode and common anode. A major advantage of the seven-segment display is that the design is simple, easy to operate, and is very low on cost. However, the disadvantage is that there are nine pins that are required to drive the display. If there is more than one singular seven-segment display, the number of pins needed to drive the display increases significantly.

One way to combat this disadvantage is to use auxiliary components such as the shift register integrated circuit. To operate the display, connections need to be made to every pin corresponding to each segment, one for the COM pin, power and ground. This requires nine connections to drive the display. Adding the shift register would decrease the number of pins required to drive the display by almost half. This allows us to connect the eight display pins for the seven-segment display to the eight output pins of the shift register and only use three pins for the shift register to the processing unit.

3.5.1.2 Electronic Ink

Electronic ink is a very interesting choice for a graphical display. One aspect of the electronic ink display is that the image remains on the display even when the power is cut off. This means that power consumption can be decreased for the system. This would help relieve the power source slightly and contribute to the requirement R.D.4, in Table 2, which states that the instrument will have an operational lifespan of at least one hour.

Electronic ink comes in a variety of sizes which is great for scalability if the instrument were to change dimensions. The largest complication, though, is that the cost of electronic ink is quite expensive in comparison to other graphical displays. The electronic ink displays on the cheaper end are too small to be able to enhance user experience and the ideal sizes are just a little too costly. One specific part that was found is the ePaper which is one of the decent sized displays

with a medium to high cost. The ePaper features a display with a resolution of four hundred by three hundred pixels.

3.5.1.3 Light Crystal Display

Light Crystal Displays, or LCDs, can be a bit too much for this project's use case. The LCD has about the same electrical characteristics as the seven-segment display but can provide much more utility. While the seven-segment display is constricted to the seven segments on the display, the LCD provides a large range of versatility. Since the LCD uses a grid of cells to produce an output, letters will be more easily distinguishable and provide the opportunity to create custom characters to display. Although the LCD is a bit more complex than the seven-segment display, however, it still provides an ease of use through simple programming methods.

In a typical 16 by 2 light crystal display, there are two rows of sixteen characters and requires sixteen pins to drive the display. The LCD can be paired with an Inter-Integrated Circuit (I2C) module which will help reduce the number of pins needed to drive the display. Pairing with an I2C module will allow the LCD to be driven with four pins just as the seven-segment display with a shift register integrated circuit. Comparing this with the seven-segment display, only one LCD module would be needed to display everything needed for the instrument. The pins needed to drive the LCD would be provided to the I2C module which will send output to the sixteen pins on the LCD.

3.5.2 Technology Comparison

In this specific project, the seven-segment display would prove to be extraneous due to the number of pins needed to drive multiple displays. The project would need eight seven-segment displays to display eight notes in the octave. This would require at least twenty-five pins for all eight of the seven-segment display used, assuming the use of shift registers. In comparison, the light crystal display, when paired with the I2C module, reduces the number of pins needed to drive the display to five pins which is only needed for one LCD. Regarding the cost of each component, the seven-segment display is slightly cheaper than the LCD; however, the project would still require eight seven-segment displays in order to satisfy the R.D.3 requirement in Table 2. This means that the cost will be slightly more to implement the seven-segment display in the end. In Table 18, comparisons can be seen between electrical properties, costs, and number of pins needed to drive the displays. The parts being compared in the table are as follows: DV-20200 as the light crystal display, HDSP-515A as the seven-segment display, and the 4.2-inch e-Paper Module from Waveshare as the ePaper.

The ePaper is a component that would work really well with this project if not for the price. Comparing it in the table, the electrical characteristics are phenomenal considering that the ePaper can continue displaying an image even when powered

off. The display itself takes up an area of 4.2 inches which could either work well by providing better user experience with a bigger display that is easier to read or be a potential problem of not being able to fit the dimensions of the instrument frame.

Table 18 LCD versus Seven-Segment Display

	LCD	Seven-Segment Display	ePaper
Operating Voltage	5 V	1.85 V	3.3 – 5 V
Operating Current	2 mA	20 mA	10 mA
Cost	\$8.95	\$1.53 each	\$29.99
Pins needed to drive display	4	5	8

The LCD will be implemented in this project because the set up will require less connections and be much cleaner to develop and modify if needed. When looking at electrical properties, the seven-segment display requires more current than the LCD screen and cost less per unit, however, when accounting for eight seven-segment displays, the LCD will be the preferred choice. Most importantly, the number of pins is based upon the use of a shift register for the seven-segment display and a I2C interface module for the LCD; therefore, the use of an LCD will also cut the cost of multiple shift registers.

3.5.3 Part Selection

The light crystal display is the selected part for the graphic display for several reasons. The LCD is more versatile in terms of displaying characters than the seven-segment display, but about equal with the electronic ink display. The electronic ink would be the most preferred part; however, it is just too costly to consider. The seven-segment display would not be viable for this project because the number of pins needed to drive all the displays needed would be too much. Therefore, the best suited choice would to go with an LCD display and interface the display with the MCU using I2C.

3.6 Audio Output

The audio output for an electric instrument is important if the device is to be used as a standalone instrument replacement. Sound quality, frequency range and the factor of how loud the instrument can be is important in a device in which the output is the audio itself. There are two main components that will be covered in this section to accomplish this: an amplifier and a speaker.

3.6.1 Research

Instruments have a large frequency of sound they cover. To be able to be a stand in as an instrument, the speakers on the device will need to be able to cover most of the ranges produced by the instruments on the device. Figure 17 shows the frequencies of notes in different octaves [27].

Note	0	1	2	3	4	5	6	7	8	9	10
C	16	33	65	131	262	523	1047	2093	4186	8372	16744
C#	17	35	69	139	277	554	1109	2217	4435	8870	17740
D	18	37	73	147	294	587	1175	2349	4699	9397	18795
D#	19	39	78	156	311	622	1245	2489	4978	9956	19912
E	21	41	82	165	330	659	1319	2637	5274	10548	21096
F	22	44	87	175	349	698	1397	2794	5588	11175	22351
F#	23	46	93	185	370	740	1480	2960	5920	11840	23680
G	25	49	98	196	392	784	1568	3136	6272	12544	25088
G#	26	52	104	208	415	831	1661	3322	6645	13290	26579
A	28	55	110	220	440	880	1760	3520	7040	14080	28160
A#	29	58	117	233	466	932	1865	3729	7459	14917	29834
B	31	62	123	247	494	988	1976	3951	7902	15804	31608

Figure 17 Note Frequencies [27]

Octaves and sounds themselves follow the rule that a note's next octave is twice its current frequency. Although Figure 17 cuts off decimal points, if using C as an example, the difference between octaves is roughly double when increasing octaves. This is most obvious in the higher frequencies when the decimal point values no longer play a necessary role. Such as between octave 9 and 10 for note C. Not explicitly listed in any figures are the breakup of the ten total octave bands: 31.5 Hz, 63 Hz, 125 Hz, 250 Hz, 500 Hz, 1 kHz, 2 kHz, 4 kHz, 8 kHz and 16 kHz [28]. Each of these bands is a range for defining a frequency's octave. The purpose of the device is to mimic the more frequently used notes of the decided instruments. Table 19 lists the frequencies reached by the instruments the team decided to add into the project.

For the purpose of testing, cheap, small speakers will work in making sure that the sounds from the result of the laser light beams being broken and unbroken happen the way the project is intended. Although this could cause issues in later stages of the project for testing by not having the data for correct power consumption, a small speaker should still suffice for the laser instrument device. If the speaker turns out to have a good quality of noise, can be decently loud and sustain notes well, it could be used for the project itself. Originally, two speakers had been considered for testing: Adafruit 1891 8Ohm .25W and SM160908-1 8 Ohm .5W because they were both small and about \$2.00 each. However, the Adafruit 1891 could only go

as low as 440 Hz, and the SM160908-1 could only go as low as about 900 Hz. Neither of these speakers would have been able to correctly play notes from a tuba, or some of the lower end notes from any of the other four instruments.

Table 19 Instrument Note and Frequency Ranges [27]

Instrument	Notes	Frequency Range
Piano	A0 - C8	28 – 4,186 Hz
Violin	G3 - G7	196 – 3,136 Hz
Flute	C4 - B6	262 – 1,978 Hz
Tuba	F1 - F4	44 – 349 Hz
Xylophone		700 – 3.5 kHz

For testing, another speaker was chosen: a 2 Watt, 8 Ohm speaker with an advertised “full range” of 200 Hz to 20 kHz. This speaker, priced at only \$1.50 at Skycraft, should be able to hit notes of all the selected instruments, even if only some of them. Measuring Dimensions: 1.22" (L) x 1.22" (W) x 0.91" (D), this part would fit in the design if testing proved it to be able to play most notes well. However, there is no datasheet for this speaker, so it cannot be proven to be RoHS. So, in the final design, a new speaker with a full range of frequencies, particularly with a strong sound in the 0 - 400 Hz frequencies, will need to be used. It will also need to be RoHS, and work with the overall design size.

Currently, this speaker would work as an inexpensive way of testing audio from the device, and it would not be a detrimental cost to the team in the event of a component malfunction. The purchased speaker was tested to verify it would work as a test speaker. Using an AC voltage, the lowest audible frequency was approximately 270 Hz, which means that the instruments chosen will all have a few notes that the speaker will be able to play. The highest audible frequency was approximately 17 kHz, which is well beyond necessary on the higher end of the requirement. To hear the lowest frequency, the speaker needed a much higher voltage to be audible. This will need to be accounted for when designing the amplifier and other audio-related circuitry.

For testing, an amplifier will be needed to connect the MCU to the speaker. A few types of circuits for amplification have been examined, particularly ones with bass boost to help with low frequency notes from instruments like tubas. This inspired a closer look into the LM386 and other types of amplifiers with circuit designs and examples from circuitbasics.com [29] as shown in the example image Figure 18. This circuit provides a good model to work from for RLC values and placements. Although designed with potentiometers to modulate the gain and bass from the audio source, these could be fixed within the overall device, set at specific resistor values or give the option to users to have more control over the sound of the instrument. This is particularly helpful for instruments that play much lower

frequency notes, such as the tuba, or if instrument files aren't too strong, the gain could be changed to produce a better, more clear sound.

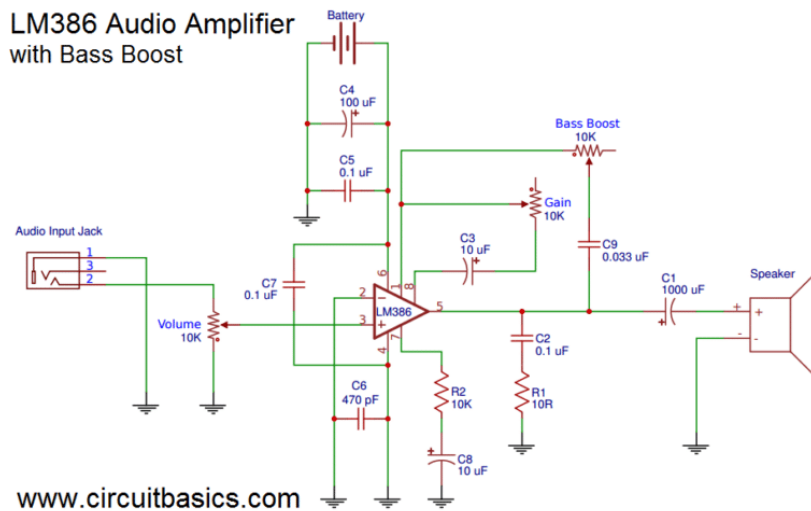

Figure 18 Bass Boost Amplifier Circuit from circuitbasics.com [29]

3.6.2 Technology Comparison

Two key devices are needed in the creation of the audio output: speakers and an amplifier device. The volume control is done by a potentiometer but is not mentioned in this section. The following two sections discuss potential devices used for audio output. Aspects such as cost, resonant frequency, size of speakers, shape of speakers, and the frequency range of the speakers are compared and analyzed to make the best selection for the laser instrument project.

3.6.2.1 Speaker Comparison

Finding inexpensive, small speakers that can properly play at lower frequencies are hard to find. Small, cheap speakers like the Adafruit 1891 mentioned above are unable to produce clear sounds at the lower frequencies needed for this specific project. Two Soberton speakers are examined in Table 20: WSP-5008-57 and WSP-5090-4. These speakers are also perfect examples of commonplace cheap, small speakers that are unable to truly reach the notes required for this specific project. Although one speaker is in fact larger and according to the resonant frequency on its datasheet should be able to cover some lower notes, it is unable to completely encompass all notes for the project. The pricing given in the table is sourced from Digi-Key.

Table 20 Speakers: WSP-5008-57 vs WSP-5090-4

	WSP-5008-57	WSP-5090-4
Cost	\$2.87 each	\$3.79 each
RoHS	✓	✓
Range	0 Hz-19 kHz	0 Hz-20kHz
Resonant Freq	530 Hz	270 Hz
Size (WxHxD)	50x50x10.1 mm 1.97x1.97x 0.40 in	50.1x90.1x31.4 mm 1.97x3.55x1.24 in
Impedance	8 Ohm	4 Ohm
Power Rating	2 W	10 W
Sound Pressure	95 ±3dB	96±3dB
Shape	Circle	Oval

Due to most speakers under \$5 being unable to produce frequencies below 200 Hz, the group will need to compromise a bit on price, frequency range and size in order to fit constraints for all three categories. To do so, new speakers needed to be found for the project. The two that satisfy most requirements are in the below table, SP700108-1 by DB Unlimited and SP-1208 from manufacturer Soberton with pricing from Jameco. The first speaker from manufacturer DB Unlimited is the much cheaper option from Arrow Electronics. The compromises for this part are its large size, and its range. The speaker would take up more space than anticipated on the frame due to being in a square frame. The larger potential hazard is that the datasheet states that the cutoff frequency for the speaker will not cover at least an octave of the Tuba.

If the error margin is large, the speaker might have trouble achieving any noticeable noise for the second lowest octave of the Tuba. This would leave the speaker with only two playable octaves. The sound pressure and the impedance of the speaker are values already explored in the following section for amplifiers. The SP-1208 speaker is one of the cheapest options with the lowest apparent range despite a high resonance frequency. The output wattage is also quite low for the 8 Ω impedance. This speaker would require much less power to be operated. It is also below the 70-dB threshold for potential hearing damage. A potential issue could be that the speaker is too quiet. A speaker that is already loud can be forced to be quieter limiting circuits. A quieter speaker can only be pushed so far before it will break. The final benefit to this speaker is that it is far smaller than any of the other speakers that have been researched.

Table 21 Speakers: SP700108-1 vs SP-1208

	SP700108-1	SP-1208
Cost	\$3.42 each	\$0.99 each
RoHS	✓	✓
Range	95 Hz-3.5 kHz	100 Hz-10kHz
Resonant Freq	95 Hz	500 Hz
Size (WxHxD)	1.97x1.97x 0.40 in	0.47x0.32x0.1 in
Impedance	8 Ohm	8 Ohm
Power Rating	10 W	.25-.5 W
Sound Pressure	96 dB	63 dB
Shape	Square	Rectangle

3.6.2.2 Amplifier Comparison

The amplifiers that are going to be used in the audio amplifying circuit will be specific to the speaker chosen to correctly match the power and impedance. Otherwise, the speaker could be blown out or not strong enough. The first two amplifiers chosen in Table 22 are TI devices that are low wattage and pricing from Mouser. They will be useful if a speaker with an impedance of 4 Ohms is chosen. The LM4990MM is a better candidate, its operating voltage is more in range of the rest of the chosen components and has a higher output power for a marginally higher cost. However, the LM386 was chosen as the testing amplifier due to easier testability. It would be suitable to test with between the higher voltage that can be tested with and a lower output voltage so that the amplifier is less likely to overpower a speaker.

Table 22 Amplifiers: Low Impedance Output Comparison

	LM4990MM/NOPB	LM386N-1/NOPB
Cost	\$1.30 each	\$1.17 each
RoHS	✓	✓
Output Power	2 Watt	325 mW
Load Impedance	4 Ohm	4 Ohm
Operating Supply Voltage	2.2 V to 5.5 V	4 V to 12 V
Power Supply Rejection Ratio	64 dB	50 dB

Due to the possibility of a 2-Watt, 8 Ω speaker being used such as the SP700108-1, Table 23 compares two different amplifiers with Mouser pricing, Maxim Integrated part MAX4295ESE+ and Texas Instrument part TPA2015D1YZHT. Immediately, one of the largest potential issues using the TI part will be the difficulty in testing with it because the part uses a DSBGA-16 type case, so there are no pins or leads to clearly connect to for testing. When designing the PCB, it will take up less space, however, due to not having pins out to the side. As a comparison, the price is much higher for the Maxim part, but it does have a higher PSRR. Power Supply Rejection Ratio is better the closer to infinity it is, so in this metric, a higher value is better. The Maxim part will also be more manageable for testing before the creation of a PCB. The valid voltages of the MAX4295ESE+ are also more like what most of the components on the board will be utilizing.

Table 23 Amplifier Comparison: 2-Watt, 8 Ohm

	MAX4295ESE+	TPA2015D1YZHT
Cost	\$2.51 each	\$1.64 each
RoHS	✓	✓
Output Power	2 Watt	2 Watt
Load Impedance	8 Ohm	8 Ohm
Operating Supply Voltage	3 V, 5 V	2.3 V to 5.2 V
Power Supply Rejection Ratio	90 dB	85 dB
Package Type	SOIC-Narrow-16	DSBGA-16

Finally, amplifiers with higher wattage and lower impedance were researched to provide the team with more speaker options to consider. Table 24 explores two Texas Instrument manufactured products with pricing from Mouser. These two amplifiers are the TPA3140D2PWP and the TAS5717PHPR. Both can amplify the signal for speakers like the WSP-5090-4. As a result of research revealing that these types of speakers are mostly available as expensive options considering the scope of this project, speakers like WSP-5090-4 will become an alternative to speakers and amplifiers that are much cheaper in comparison. The two products mentioned in Table 24 both require higher voltage than most components on the board. They are also much larger and require more in-depth pin connections. Unless WSP-5008-57 or similar speakers are unable to produce quality sound with their accompanying amplifiers, the amplifiers compared below and the speaker they are modeled for will not be further considered as an option. For the purposes of this research section, the viable options for the project must be included.

Table 24 Amplifier Comparison: 10-Watt, 4 Ohm

	TPA3140D2PWP	TAS5717PHPR
Cost	\$2.51 each	\$5.41 each
RoHS	✓	✓
Output Power	10 Watt	10 Watt
Load Impedance	4 Ohm	4 Ohm
Operating Supply Voltage	4.5 V to 14.4 V	4.5 V to 26 V
Power Supply Rejection Ratio	80 dB	High (not listed)
Package Type	HTSSOP-28	HTQFP-48

3.6.3 Part Selection

Revisiting both parts of the audio output, the speaker and the amplifier used in the audio amplifying circuit, selections are made in terms of the specific devices. Both of these parts have been decided on based on the likelihood of satisfying project requirements while being able to work within constraints.

3.6.3.1 Speaker

The SP700108-1 by DB Unlimited appears to give the group the most versatility with a speaker for its price. The size of the speaker will fit within the frame constraints, the resonant frequency is lower than at least half of every instruments range. Although the shape of the frame for the speaker is not exactly what was planned for, it will be easier to mount to the frame with its corner holes. Although the speaker is rated louder than the health constraint, the speaker circuit can be modified to prevent the speaker from reaching potentially damaging levels. Although the cost is high for a part that the final design will need two of, it is a cheaper alternative than many speakers with similar specifications.

3.6.3.2 Amplifier

For testing, LM386N-1/NOPB was ordered to begin to understand and work with amplifiers for the sake of the project while research on speakers for the design and corresponding amplifiers continued. The amplifiers purchased next will be dependent on the speakers purchased and what is found during testing with the LM386N-1/NOPB and the speaker purchased from Skycraft. The amplifier that will work best will be the TPA3140D2PWP. With two 8 Ohm speakers in the circuit, only 4 Ohms will be needed for the audio, and will be rated lower than the two speakers, preventing a potential blowout from mismatch of impedance. This isn't

the cheapest of amplifiers compared to the TI LM386N, but for the ratings needed for higher power speakers, this is manageable for only needing one in the circuit.

3.7 Bluetooth

Bluetooth or possibly Bluetooth Low Energy (BLE) was the groups decided method of communication between a phone with an app specific to the project and the instrument itself. As a direct connection between two devices, BLE can be a relatively inexpensive, in the sense of processing power and energy consumption, method of communication.

3.7.1 Research

Bluetooth and BLE are communication standards set by IEEE. Bluetooth is short-range communication sent between the 2400-2483.5 MHz range with 79 channels 1 MHz in bandwidth [30]. Bluetooth LE is the same communication range but the interaction between the devices is what uses less energy. BLE is better for communications that don't require constant connections or are low amounts of data. Considering how small the MIDI communication packets are, BLE will work for the project. This reduction in power will help retain battery life of the device while it is connected to a phone utilizing an app.

As it stands, there are libraries from not just free open-source sharing networks, but well-documented libraries from many available different devices to handle BLE communication. With the more updated versions of Bluetooth communication in newer chips, BLE v5 has increased capabilities. Some of these powerful new abilities include a higher throughput of almost 2 Mbps, a longer range, although at reduced throughput, and improved interference avoidance [31]. The newest version, 5.1 allows for location and positioning. Although using Bluetooth v5 or v5.1 would use cutting-edge technology, most of the features that sets it above v4.2 aren't pertinent to this project. By recognizing that the group isn't limited to v5 and above, and that v4.2 devices are still the most common, and therefore cheaper, the group has more possible options as far as Bluetooth capable devices. Most importantly, v4.2 will satisfy the distance requirement of the project, able to connect well beyond the 3 feet, up to almost 30 feet.

3.7.2 Technology Comparison

Originally, the group investigated selecting chips that were Bluetooth-specific, that the only job the Bluetooth chip had was to handle the communication between the phone app and the instrument. However, after some research on the communication process between a chip and some other processing chip within the device, the solution appeared to be to instead pick a chip that included Bluetooth and handled all communication natively.

In the process of deciding how to approach what was wanted and needed for the Bluetooth module, necessary in communicating wirelessly to an application, research was completed as a comparison of two different modules. This comparison is summarized in Table 25 and explained in a much larger breakdown following the table. The below comparison is what changed the groups decision from using a small Bluetooth specific chip to a larger, more robust device that could handle both the processing of the device and the communication between the instrument and a phone.

Table 25 Bluetooth Comparison Chart

	BL651 453-00005 Laird	ESP32-SOLO-1 Espressif
Cost	\$4.99	\$3.40
RoHS	✓	✓
GPIO Pins	32	32
Supply Voltage	1.7 – 3.6 V	3.0– 3.6 V
Power Consumption	2.1 mA–7.0 mA peak	28 mA – 240 mA
ADC	8 channels	8 channels
MCU – Storage	192K	448K
MCU – RAM	24K	520 K
MCU	ARM Cortex M4 [64MHz]	Xtensa 32-bit LX6[40MHz]
Size	14 mm x 10 mm x 2.1 mm	25.5 mm x 18 mm x 3.1 mm
Bluetooth Protocol	v5.0	v4.2

The Bluetooth Module from Espressif is very dynamic and would help the project by taking some of the processing from the device’s main MCU and could potentially replace the need for any MCU. The on-module storage would help to keep information running smoothly and fast between the device and whatever the app might be. This part is cheaper as well, helping keep costs down as the team may require multiple Bluetooth modules in the event that some fail during testing. This specific model also has the capability of Wi-Fi, with 802.11 b/g/n protocols. Espressif also offers a large GitHub wealth of open-source software to help users with their projects, including an Audio Development Framework. The largest downsides to this specific part are the energy draw and the large board footprint.

As one of the specifications requires the device to run off a battery, this is an egregious amount of power to be taken up by a single component. Even if the module does not pull that much power all the time, it still could cause a large draw

on the battery. The size of the Espressif module could also pose a threat to the specification regarding size. The module is nearly twice as large as the BL651 module, and its antenna will take up much more nothing space on the PCB to accommodate the required space. This is another area that will rack up cost, as building the PCB to accommodate the module footprint and blank space for the antenna will add up to more costs.

Even though a few of the BL651 modules for testing and prototyping would create more cost now, the much smaller footprint and antenna space will save costs on the final PCB and keep it smaller overall. The device can run as not only a lower voltage, but a much smaller energy consumption than the Espressif module. This module is also programmable using JTAG.

Table 26 ESP32-SOLO-1 vs ESP32-WROOM-32D

	ESP32-WROOM-32D	ESP32-SOLO-1
Cost	\$3.80	\$3.40
RoHS	✓	✓
GPIO Pins	36	36
Supply Voltage	3.0 – 3.6 V	3.0– 3.6 V
Power Consumption	28 mA – 240 mA	28 mA – 240 mA
ADC	8 channels	8 channels
MCU – Storage	448K	448K
MCU – RAM	520K	520 K
MCU	Dual-core Xtensa 32-bit LX6 [40MHz]	Xtensa 32-bit LX6 [40MHz]
Size (mm)	25.5 x 18 x 3.1	25.5 x 18 x 3.1
Bluetooth Protocol	v4.2	v4.2

Both modules have 32 GPIO pins, which should be enough to potentially control the laser diodes if the app were given control over the device, and at a minimum will be able to read the values from the chosen light-sensitive sensors for the project. The modules are also capable of multiple forms of communication to the MCU, equipped with UART, I2C, and SPI, and have the option for ADC pins to give more flexibility in other places of the project.

After a comparison of the ESP32 devices to other competitors on the Bluetooth LE marketplace, such as TI, Dialog Semiconductor, Nordic Semiconductor and Silicon Labs, the Espressif ESP32 modules appeared to have the better size, storage, and capabilities for their price. In Table 26, two different Espressif ESP32 modules are compared, the ESP32-SOLO-1 and the ESP32-WROOM-32D. Although by the

table these parts look nearly identical, the largest difference is that for only \$0.40 more, the WROOM has a dual core. The largest benefit to this will be the ability to use one core for communication processing and the other for handling MIDI file creation if the device is being played and communicating to an app. The devices require the same consumption for RF communications, and although 240 mA is listed at the higher end of the consumption on the table, BLE only draws up to about 130 mA. The average consumption for the WROOM is listed at only 80 mA per its datasheet. Both modules have v4.2 Bluetooth and BLE, which will be sufficient for this project.

3.7.3 Part Selection

For easier testing, a development kit for ESP32-WROOM-32D was purchased. This chip is what the team plans to use moving forward, so the team purchased a development board with circuit protection, communication using USB-mini to flash programs, and pins to connect the board to components on a breadboard. These chip safety features will be useful in testing without as much risk to the chip. The features of the board will make changing memory, programs and other software easier until all software is finalized. Singular chips were also purchased for when testing beyond basic programming and testing is completed. If the processing power of the ESP32-WROOM does not meet the team's expectations and produces a delay in playing instruments, communication errors, or creating MIDI files, then another system on a chip with Bluetooth LE capabilities will need to be used.

3.8 Musical Instrument Digital Interface

The laser instrument will have an audio output option from the major music instrument groups: piano, string, woodwind, brass, and percussion. Musical Instrument Digital Interface (MIDI) files are a way of creating data from MIDI keyboards to be played by synthesizers. The data created contains information about the key played, when it was played, and some extra information to make the sound richer and contain effects that an actual instrument might have. The details of the specifications list, created by the MIDI Manufacturers Association, list out how packets are sent, stored, and created. There are large libraries that are dedicated to embedded software for creating the files from MIDI instruments, such as electronic keyboards. MIDI files have been used as ways of reducing the overall space needed for music and sound by giving 'instructions' of what specific notes to play and when.

3.8.1 Research

MIDI and its specifications will be covered within the embedded software of the team's chosen microprocessor. This specification is how the data taken from the

photo sensors will be used in creating the correct output using the stored audio files. The normal application of this specification is for keyboards that are connected to sound modules to synthesize an instrument which are connected to speakers. MIDI files are also known as MIDI messages as they are messages to the synthesizer to instruct the device how to play.

The Channel Voice Messages are broken into the following categories: Note On / Note Off / Velocity, Aftertouch, Pitch Bend, Program Change and Control Change: Bank Select and RPN/NRPN. From there, Channel Mode Messages and System Messages are MIDI messages that are focused on data communication, system information and synchronization. The team will unlikely use much more than the first category, which is when the specified note is played. The other categories modulate how the note is played by changing how hard or soft, or other special effects to change the waveform.

MIDI is sent as a status byte followed by one to two data bytes. The data bytes are sent with an MSB of 0, and then are set up as per tables described in the documentation per the status byte that it follows. From there, the exact bytes are broken down depending on what the status byte dictates. As per an example given by the documentation, a message of 903C40 would mean Note on #60 and 803C40 is Note off #60. These example instructions are how MIDI tells the player to turn a note on and off. Luckily, most of the exact breakdown is handled by expansive libraries available for public use. If the group does in fact choose to use an ESP32 type device, there are tutorials and Github code provided by Espressif to work with MP3 files and MIDI files. The documentation from the MIDI Association gives options for multiple notes to be played at once, or one at a time, omni on vs omni off. If later in software development the team decides that multiple notes being played simultaneously is too difficult, MIDI gives the option to play only one note at a time.

Using this information, there are several suggested hints given by the MIDI 1.0 documentation. The first of which, in relation of this project, is the looping of sound for longer notes held longer than the sound file. The documentation suggests looping the note from after the 'attack' and initial 'decay' portions of the note, looping the sustain portion until any release. The next tip will be compression of data. Being as the team hopes to have at least a full octave of 5 different instruments, this section will be important in keeping sound files small so that there is less delay on the instrument playback without sacrificing too much quality. To further reduce space, the documentation explains the potential of taking notes from an octave of each instrument and modifying the playback files frequency to mimic notes an octave higher or lower. Given time to develop, this potentially might give the instrument more space to hold all instrument sound files and mimic notes and not even need to use an external storage. This last tip will be utilized if given enough time to fully develop on the MCU.

3.9 Microcontroller Unit

The microcontroller unit, or MCU, is the central computational device in the project. While choosing the MCU, many parts must be accounted for and the engineering specification requirements are at utmost importance. Many characteristics and features depend on the use case within the project. Some key characteristics of a microcontroller unit to look for are processing power, memory, hardware architecture, software support, and cost [32]. Additionally, the pin count is equally as important as the previous characteristics to account for all components within the project.

3.9.1 Research

Microcontrollers and microprocessors are two different processing components that can be easily confused. Microprocessors do not include some features that are required for the laser instrument, such as memory and general-purpose input and output pins like a microcontroller [33]. The microcontroller is best suited for this project due to the requirement of small programs to run various tasks. Much of the research for this section went into the comparison of the available options for MCU, as detailed in 3.9.2. To compare these different microcontroller, the focus lies within multiple characteristics, such as number of pins, processing power, hardware support, and cost. This project requires a microcontroller chip that can support a portable instrument, as well as execute the many tasks required of the instrument.

Originally, the first microcontroller options explored were ones without Bluetooth built into the System on a Chip (SoC). The research of the two chips was kept as a comparison to the technological differences to the Bluetooth chips besides the RF communication. Bluetooth MCU options began to be the preference of the group upon the realization that having native Bluetooth in the chip would reduce strain on the chip, free up communication to other parts of the device, and prevent the possibility that there would be issues communicating between the MCU and the Bluetooth chip.

3.9.2 Technology Comparison

One of the most popular choices when dealing with hobbyist electronic projects is the Arduino. The Arduino is great for testing components and capabilities. Since the Arduino utilizes the ATmega328, it is a great microcontroller chip to consider. First and foremost, the microcontroller chip has thirty-two pins, which is a good amount to consider for this project and should have enough general-purpose input and output pins to connect all the components required for the instrument. The number of pins needed would be necessary to consider during the stages of testing and integration. Additionally, the microcontroller has a voltage range of 1.8 volts to 5.5 volts. The development environment that this microcontroller makes use of

is the Atmel Studio IDE. This program is compatible with C, C++, and assembly code languages, which is a viable option for the team. When it comes to memory, the ATmega328 possesses thirty-two kilobytes of flash memory [34].

Another competitor for a microcontroller unit chip would be the MSP430G2553. This microcontroller features an ultra-low power consumption. This would help keep the instrument power efficient and support the project requirement R.D.4 in Table 2. In comparison to the ATmega328, this microcontroller chip has a lower voltage range of 1.8 volts to 3.6 volts. For the number of pins, this microcontroller chip is less favorable due to having up to twenty-four input and output pins, which could potentially be a problem of too few pins.

Table 27 MCU Comparison: ATmega328 vs MSP430 Computing

	ATmega328	MSP430G2553
Cost	\$1.83	\$2.25
RoHS	✓	✓
Memory	32 KB Flash	16 KB Flash
RAM	2 KB SRAM	512 Byte
Core(s)	AVR core, 32-bit	Single 16-bit
Bluetooth	No	No

In the Table 27, the comparisons can be seen between the ATmega328P-AU and the MSP430G2553IRHB32R. In Table 27, the processing power, cost and constraint data is compared. The two microcontrollers are appealing for their cost but will not be enough to satisfy the needs of a project that requires the processing for audio file playing and creation of MIDI files, along with communication ability.

Table 28 MCU Comparison: ATmega328 vs MSP430 Physical

	ATmega328	MSP430G2553
GPIO Pins	23	24
Supply Voltage	1.8 – 5.5 V	1.8 – 3.6 V
ADC	8 channels	8 channels
Power Consumption	0.2 mA at 1 MHz, 1.8 V	0.23 mA at 1 MHz, 2.2 V
Size	9.25 x 9.25 x 1.2 mm	5.3 x 5.3 x 1 mm
Bluetooth	No	No

As seen in Table 28, the two chips are compared for power and size constraints. One large downfall to the MSP MCU is its inability to power other devices through its GPIO pins. Both devices don't consume very much power, either, which is important in a device intended to be portable. They are also very small in profile,

a cost saver when it comes to PCB design and overall project design. With the discovery of the general ease of using a system on a chip that included Bluetooth in the chip, the ESP32 series of devices and the Texas Instruments lines of products were considered as options. The most important features of the two different MCUs are compared in Table 29 and Table 30. The pricing of the two is given by Mouser.

Out of all the ESP32 devices, the ESP32-WROOM-32D gave the most appealing options. As a dual-core device, there are several possibilities, such as forcing a core to focus on communication, and the other to focus on the needs of the device. The chip also has much more memory, allowing it to handle the strenuous task of handling audio files. The chip itself isn't much more expensive than most single-core market counterparts and is inexpensive overall. The ESP32 devices have a comprehensive library and verbose documentation. Espressif has a well-explained setup for the programming environment, Eclipse, with the changes needed to include the Espressif library to correctly compile the programs. Of all the libraries included, the most pertinent to the project is the library for MIDI files, with native controls for using files, creating them and sending them over Bluetooth and Bluetooth Low Energy.

Table 29 MCU Comparison: ESP32-WROOM vs CC2642R1F Computing

	ESP32-WROOM-32D	CC2642R1F
Cost	\$3.80 each	\$6.44 each
RoHS	✓	✓
Memory	448 K	352 K
RAM	520 K	80 K
Core(s)	Dual-core Xtensa 32-bit LX6	ARM Cortex M4F
Bluetooth	Yes, v4.2	Yes, v5.0

Texas Instruments offers Bluetooth with low power options. The model CC2642R1FRGZT was considered as an option. A powerful but not power-hungry chip, for devices with portability in mind, it's an alternative to consider. Like the MSP430 and other TI products, the CC2642R1F is developed within the Code Composer Studio. This unfortunately is a newer product and the libraries from TI for audio, MIDI, and the newest versions of Bluetooth are currently being released. With this being the case, there won't be many references or help available for this kind of project. This product has very little memory in comparison to the ESP32 device, and only one (albeit powerful) core. The chip itself is still very expensive for what it offers for consumers.

Table 30 lists the differences between the ESP32-WROOM-32D and the Texas Instruments CC2642R1FRGZT. The ESP32 and the CC2642R1F both offer two

important chip-internal options for pins: Analog to Digital Converter (ADC) and Digital to Analog Converter (DAC). For the reading of the photo sensors, ADC pins will be useful in deciding the thresholds for covered and exposed lasers within the chip. The DAC pins are necessary in removing a need for an external DAC to play audio. Both chips offer more pins than the base instrument will require, allowing for potential expansion or room for error. The TI chip offers a significant decrease in overall power consumption compared to the ESP32 device. The TI product is also much smaller and will take up less space.

Table 30 MCU Comparison: ESP32-WROOM vs CC2642R1F Physical

	ESP32-WROOM-32D	CC2642R1F
GPIO Pins	36	31
Supply Voltage	3.0 – 3.6 V	1.8 – 3.8 V
ADC	8 channels	8 channels
DAC	2 Pins	2 Pins
Power Consumption	28 mA – 240 mA	.03 mA – 9.6 mA
Size	25.5 x 18 x 3.1 mm	7.3 x 7.3 x 1.1 mm

3.9.3 Part Selection

To compare the parts in Table 27, the important characteristics can be seen. All options listed in the table support 8 channel ADC and a range of functional supply voltages. The minimum pin count is 23 pins, which is suitable for the purposes of this project. The most valuable characteristics of the microcontroller units in question is the internal RAM and if Bluetooth is an included module. The ATMEGA doesn't offer enough for the project. There are not enough pins, not enough on chip memory, and no Bluetooth. The MSP430 device is similar to the ATMEGA in not offering enough to support the project. There is barely any memory on the chip, few pins and no Bluetooth. CC2642R1F has less memory and ability in comparison to the ESP32 and is much more expensive but is smaller and requires less power.

The selected microcontroller unit to use in the final product of this project is the ESP32-WROOM-32D. The included Bluetooth is highly valuable because it means there is no requirement for an additional external module to connect to and configure, reducing design time and physical space. It also saves money by condensing potentially two or more parts into one. Included Bluetooth makes it easier to connect to the controller with default communication capabilities. The relatively large amount of internal memory on this part is also highly beneficial to the project. This allows for quicker response times and longer instructions, made especially useful if all 36 pins on the unit are eventually utilized by the end of this project. The chips dual core allows for more to be accomplished simultaneously,

important for a device handling communication and file processing. The cost is low for the chip, one of the final deciding factors.

Although the Bluetooth version is only v4.2, it will be more than enough for the project, and is supported by more devices than the newest version, v5, which is part of the CC2642R1F device. Using only v4.2 will help in development due to having more resources available because it has been out much longer, but not long enough that there is a fear of the chip becoming obsolete within even the next few years. Three of these ESP32 chips have been purchased to begin the process of testing, along with a development board to become comfortable with the chip without risk of damage.

3.10 Battery and Power

The choice of power is an important choice when it comes to the parts used for the instrument. Depending on the parts chosen for the project, the power will need to follow specific requirements. The main components that require power usage include the laser diodes, photosensors, the graphical display, Bluetooth, and, of course, the microcontroller chip. These must all be considered for the power consumption of the battery. The power source should be strong enough to power all of these components at least. Choosing a wrong power source could pose a potential threat to the components. If a power source is too high, there is a possibility of damaging the microcontroller unit and possibly other components within the system. Most components research for the project require a voltage source of 3 V to 5 V which will be put into consideration for the battery selection.

3.10.1 Research

There are a couple options when it comes to power within embedded systems. The three major types of power supplies are unregulated linear power supplies, regulated linear power supplies, and switching power supplies. Additionally, batteries can also be considered as a power supply for this project. Keeping in mind that the project must be portable, the power sources could be narrowed down to several options.

3.10.1.1 Lithium Ion and Lithium Polymer

Lithium ion and lithium polymer are very similar in attributes. These batteries are some of the upcoming batteries that are becoming more common. They are most commonly used in consumer products such as cell phones. Lithium ion and lithium polymer batteries are a very viable option due to their light weight and high energy density. The voltage that these batteries output is approximately 3.6 volts and are enough to power the microcontroller unit that the instrument is projected to use which takes 3 to 3.6 volts. The discharge of these batteries goes up to 2 C which contribute to the operational time requirement. This translates as being able to

support the delivery of two amperes for thirty minutes when rated at one ampere hour [35].

The geometry of the battery should also be considered when choosing one. The components within the instrument are restricted to the dimensions of the frame. A smaller and compact battery would benefit this project, but the electrical characteristics can differ based on sizes. Normally, the lithium ion batteries take the form of cylindrical and prismatic shaped batteries and lithium polymer batteries are more of a “pouch” shape.

3.10.1.2 Nickel Cadmium

Nickle cadmium (NiCad) is one of the oldest batteries used for rechargeable power which was overshadowed by Lithium batteries later in history.

One of the advantages that NiCad batteries offer is low internal resistance which is a valuable trait since a lower resistance would mean that energy can more efficiently flow from the battery to the device. The NiCad batteries come in a variety of sizes and capacities that will aid with choosing a power source that can fit in the dimensions eligible for the device’s frame. Another alluring advantage is sealed NiCad cells can be stored in a charged or discharged state without damage unlike LiPo batteries which cannot be stored until they have reduced to a specific voltage range.

The largest drawback of implementing NiCad batteries is their susceptibility to memory effect. Memory effect causes a battery to gradually lose its maximum charging capacity if it is continuously recharged while the battery is only partially discharged. This is because the battery “remembers” the smaller capacity it held while being only partially discharged. To prevent this, the battery must be fully discharged prior to recharging or selecting a more expensive battery that can perform the operation on its own. NiCad batteries are also prone to damage by overcharging and require re-sealing safety vents to prevent any damage from overheating and pressure build up [36].

3.10.1.3 Lead Acid

Lead acid batteries are the oldest type of rechargeable and are robust, very resilient to abuse, and relatively low in cost. However, lead acid batteries are very large and heavy for applications that require higher power consumption and intermittent loads. Being an old-standing battery, they are very reliable when used, robust and tolerant to abuse, and less susceptible to overcharging unlike NiCad batteries. Although the laser instrument device will not be intended to face severe abuse, a robust battery is still a reliable component to have. The indefinite shelf life of lead acid batteries would be attractive to this project because there could be prolonged periods of time in which the device may not be used prior to a user abruptly turning on the device.

Despite the high reliability and low cost of lead acid batteries, they tend to be very heavy and bulky compared to other options. This would not adhere to the project's requirements of a light weight and portable device. Lead acid batteries also must be stored in a charge state. Storing the batteries in a completely discharged state for prolonged periods of time may result in the batteries having increased internal resistance. This would make it more difficult for the battery to supply power to the necessary components which would not be preferable for the laser instrument device [37].

3.10.1.4 Alkaline Batteries

Alkaline batteries would offer many advantages to this project. Compared to Nickel Cadmium batteries, alkaline have for times the capacity of an equivalent size. Alkaline batteries can operate at sub-zero temperatures which is a valuable feature, however the laser instrument project will not require such an extreme aspect from its selected power source. Alkaline are also available in a wide range of sizes and suitable for a vast amount of applications. Unfortunately, alkaline are not normally rechargeable or are not optimized for rechargeable functionates. In addition, alkaline batteries typically have a low cycle life. This could result in frequent replacement if chosen for the device's power source [38].

3.10.2 Technology Comparison

Some of the features of each battery that the team considered critical in the selection process for a suitable power source are listed in Table 31. Cost was considered since one of the project's main objectives is to be an affordable design. Another main objective is to design a device that is light weight and portable. Being as the battery is arguably one of the heavier components of the device after the frame material, considering a battery's weight is important to honoring the requirements and constraints of the project. Life span, cycle life, and memory are important to distinguish which types of batteries will require more replacements for the prolong usage of the laser instrument device.

Table 31 Battery Comparison

	LiPo	NiCad	Lead Acid	Alkaline
Cost	Moderate	Moderate	Low	Low
Weight	Low	Low	High	Low
Lifespan	High	Moderate	Moderate	Low
Cycle life (cycles)	1000 - 3000	500	300 – 500	100
Memory Effect	No	Yes	No	Yes

One of the most notable comparisons in Table 31 is the considerably larger cycle life of the LiPo battery and the comparably much lower cycle life of the alkaline battery. LiPo and NiCad batteries are generally more expensive compared to lead acid and alkaline batteries, however it must be taken into consideration that the lifespan of lead acid and alkaline batteries are commonly shorter to LiPo and NiCad. NiCad and alkaline batteries suffer from memory effect which does not allow them to be prolonged shelf lives unless fully discharged before storing.

3.10.3 Part Selection

The heavy weight and low cycle life of lead acid batteries make them an undesirable choice when compared to the other options researched in this section. This compromises the project's requirement to maintain a portable design. Alkaline batteries also suffer from a low cycle life in addition to being prone to memory effect. This would require constant replacement of the batteries which be another undesirable feature to implement in the laser instrument design.

LiPo and NiCad batteries would be the remaining choices based on the research conducted. NiCad does not would no burden the project with additional weight compared to the lead acid batteries, and it has a much higher cycle life compared to alkaline batteries. Where the NiCad batteries fall short are being compared to the LiPo batteries. NiCad does not exhibit nearly as long of a cycle life and unfortunately is vulnerable to memory effect like alkaline batteries.

Despite a higher price point compared to other options of rechargeable batteries, LiPo batteries would be the best fit for the laser instrument project based on the research and comparisons highlighted in this section. LiPo batteries are becoming more common when it comes to rechargeable batteries, and they can come in a compact size, have a considerably longer cycle life to other options, and can be very lightweight. This would contribute to the project's requirement of being a portable instrument. LiPo batteries are also not susceptible to memory effect. A major aspect of LiPo batteries that the team must consider during implementation is LiPo batteries require protective circuitry prevent overheating and possible explosions [39].

3.11 Audio Storage

The storage system used in this project affects the access time, read time, and response time between user input and audio output. These delays directly affect the satisfaction of multiple engineering and market requirements. The user must be able to operate the final instrument in real time, with the intended function to simulate a real instrument that does not use lasers. The storage of the device's audio files directly correlates with the cumulative response time that the user will experience during regular usage of the instrument and must therefore satisfy its own list of requirements in order to be used in the final product of this project.

3.11.1 Research

The audio storage of this project affects the engineering requirements of data retrieval rate, instrument reaction speed, and the number of instruments supported by the standalone device. The audio storage used must be accessed and read quickly and must have enough storage space to hold the necessary number of audio files for the laser instruments. The accessing and reading of the audio storage must happen in real time and must have enough storage for at least five instruments as declared were the minimum number of types the team will be implementing on the device.

The two most popular audio storage systems to use in mobile devices such as the laser instrument of this project are Universal Serial Bus (USB) flash drives, and Secure Digital (SD) cards. Both storage systems are commonly used because they are small, and therefore portable and fit easily in a handheld device. They can be quickly disposed of or interchanged with another storage device, making them ideal for short term storage of data. These storage systems are generally intended for short term storage. They're made equally readable and writable with the expectation that data stored on them will be eventually deleted or moved to a long-term storage device. While still able to store data for long periods of time, including permanently, they are typically designed with smaller capacities than their long-term counterparts.

These long-term counterparts, and less popular media storage devices, are external drives like hard disk drive (HDD) and solid-state drive (SSD) and discs (CD). External drives are known to have much larger storage spaces but are also physically larger. While an SSD is arguably fast enough to operate for this project, there would be a largely unused portion of memory and physical space that would ultimately affect the final weight and dimensions of the laser instrument. The larger storage spaces also result in a higher component cost, making the waste physical and storage space an extra detriment to the project.

CD's have limited storage space because they are limited by the physical writing space available on an individual disc and the difficulty with writing and rewriting over the same data for a single disc. However, disc readers can operate at a real time speed, which would satisfy all the team's established requirements that emphasize a device that can support real-time operation. Discs also have some of the highest data transfer speeds out of all media storage devices. Research has found that this is a common misconception. Discs are only considered to have higher data transfer rates because they can be more easily physically transferred to another location, for instance from one city to another, and can therefore consider their long-distance data transfer rate more competitive compared to other media storage devices. All these storage devices require mechanical components that increase physical size, noise level, and maximum operation speed.

3.11.2 Technology Comparison

USB flash drives are popular because of how inexpensive they are compared to other storage devices. It is universally applicable, so it can have many file types written to it and be read by almost all existing systems. However, to keep this universally applicable there is typically a tradeoff with storage space and read/write speed. For this project, the write speed has limited effect on the final product. The newer versions of USB, USB 3.0, can solve the potential problem of slower reading speed, but that combined with needing more space on the media greatly increases the cost.

SD cards are popular for their portability and speed but can be a more expensive media storage device compared to other options. They are also much more unreliable from one card to another, varying in speed based on the model and brand of the card. They typically have more storage than other storage options because they are used mostly for media storage such as audio, photo, and video. Since this is their most common use, they are expected to react in real time when saving new media from a mobile device or streaming saved media to said device.

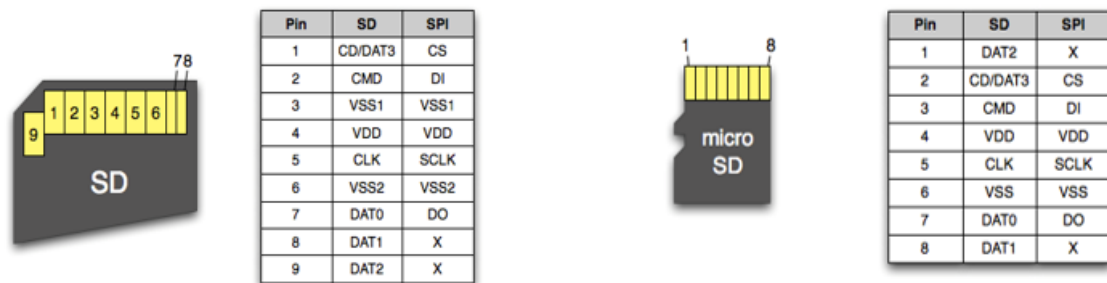

Figure 19 Secure Digital (SD) Pinout

Hard Disk Drives and Solid-State Drives are extremely standard storage devices used in computers and other electronic devices around the world. Highly standardized, HDDs are mechanical devices that contain a rotating disc that is read by an arm. Operational speed is dictated by the rotations per minute of the disc, affecting both read and write times. This mechanical characteristic makes it difficult to improve upon within confined dimensions, increases noise levels, and makes it more expensive than it is probably worth. They used to be worth the price, but SSDs are in the process of replacing HDDs. Requiring no mechanical parts, an SSD improves operation speed, size requirements, and capacity in comparison to the HDD. However, an SSD is still typically much more expensive than its counterpart when purchasing devices with the same data capacity. The tradeoff between cost and performance is most likely the deciding factor when selecting a storage device between these two.

A Compact Disc is widely used because of its long-term applicability and physical design. A standard CD can be read by any disc reader around the world and is read using various interfaces. A CD requires a disc reader, which has the true impact on performance speed. They have rotating mechanical components, like an HDD, that generate more noise and less room for improvement than other storage systems can offer. Where the CD lacks in potential operational speed, it excels in portability. The disc's flat design allows for many to be stacked with one another, holding extremely high amounts of data in a smaller space and able to quickly and easily transport said data.

Almost every computer in this day and age is expected to have some sort of disc reader, which means that a CD can be expected to be shipped anywhere and be readily readable. Since it is so easy to transport and there are minimal delays in prep time when reading the data, they have some of the highest recorded data transfer rates when accounting for physical distance travelled across the globe. There is no need for a constant connection, making CDs a cost-effective offline storage device. An individual disc is limited in its storage space, but since they can be stacked collectively, they can be addressed as a group when calculating capacity.

Table 32 Storage Device Comparison

	Data Transfer Speed	Capacity	Physical Size	Cost
USB	Moderate	Low	Low	Low
SD	High	Low	Low	Moderate
HDD	Moderate	Moderate	High	High
SSD	High	High	Moderate	High
CD	Moderate	Moderate	Moderate	Moderate

In the context of Table 32, the greatest benefits to this project would come from high data transfer speed, high capacity, low physical size, and low cost. The most important of these aspects compared is data transfer speed. This is critical since the project does not have a large amount of data to store for long term use. The physical dimensions are limited by the device's frame, and the team intends to keep costs down in the long run by purchasing suitable parts at the beginning without the need to replace later. Table 33 highlights the dimension and cost comparisons between the BOB-00544 and the MICROSD-ADP.

Table 33 Audio Storage Readers Comparison

	SparkFun BOB-00544	Gravitech MICROSD-ADP
Dimensions	0.9 in x 0.9 in	1.4 in x 0.8 in
Cost	\$4.50	\$14.50

The information in Table 34 demonstrates the greater storage capacity, sustained read, and sustained write of the SDSDQAF3-032G-I compared to the AP-MSD08GIE-AAT. Even though the AP-MSD08GIE-AAT comes at a lower cost, it does not provide as many benefits as the SDSDQAF3-032G-I.

Table 34 Audio Storage Devices Comparison

	SDSDQAF3-032G-I	AP-MSD08GIE-AAT
Capacity	32 GB	8 GB
Cost	\$30.15	\$7.99
Sustained Read	80 MB/s	43 MB/s
Sustained Write	50 MB/s	41 MB/s
Configuration	MLC	SLC

3.11.3 Part Selection

The final design of the laser instrument includes an audio storage method that is either from USB or SD. USB is more inexpensive and can be set up quicker, improving the overall cost and design time of the project. SD cards run quicker but require more setup and overall cost.

USB can reach comparable speeds to SD cards when upgraded to USB 3.0, but that increases the cost of the USB storage device. The cost is also increased for USB in order to meet the same storage space expected in a standard SD card, so USB has an obvious disadvantage in terms of its effect on cost of the project.

SD cards are already known for their applicability to mobile devices and their interaction with media such as audio files, so that is the audio storage method selected for this project. They are more expensive, but a single card can be reused plenty of times within the scope of this project, so it is expected to only be a single time expense. The audio storage has the heaviest effect on the engineering requirements of data retrieval rate, instrument reaction time, and the number of instruments supported, so the team decided to go with the storage method that has more reliable speed. Spending the extra money to get a quality SD card would further support the final device to operate as intended in real time and provide the ideal user experience. The specific SD card and card adapter selected for testing for this project is the SanDisk SDSDQAF3-032G-I and the SparkFun BOB-00544. They were selected over their competitive counterparts because they are cost effective, leave capacity for the project to improve in the future, and have high data transfer rates for satisfying the project requirements.

3.12 Application

The application that the team would like to implement is an android-based app. This is mainly due to the cost of a developer account with Apple is \$99 annual, whereas the cost of a developer account with Google Play is a one-time fee of \$25

dollars. Keeping this cost down will be reflected in the overall budget of the project. This application will be created in Senior Design 2, when parts are in, and the instrument prototype is able to communicate with a phone application.

3.12.1 Programming Environment

Before immediately deciding the programming language and the Integrated Development Environment (IDE), the team chose to compare and research the best options before starting. Two competing Android languages are Java and Kotlin for app development.

3.12.1.1 Language: Java vs Kotlin

Given the choice of language with which to create an app to supplement the device, the team considered two choices, Java and Kotlin. Both languages are supported within Android Studio, which two team members were already familiar with. Both languages can call the other and use their library functions.

Kotlin has gained a following on the app market for condensing Java code. In some cases, reducing the same exact app in Java to only three-fourths the number of lines of code [40]. More apps are being made from the language that compiles as fast as Java, or in some cases, compiles with less time. Kotlin was built from Java, and with some tools, Java class files can be turned into Kotlin files.

Java has been around much longer than Kotlin, and as such, there is less support in Android Studio for Java. Demand for Java is decreasing in comparison to Kotlin. However, the entire team is comfortable with Java, and two of the members have used Java and Android Studio to create an app for another project.

The team's final decision was to use Java to create the overall app. If there are libraries that are Kotlin-specific, they can be implemented in the Java code. Otherwise, team members would not need to then learn another language on top of the responsibility of the app. Beyond that, team members that had worked on an app previously could take their experience with the previous Java-written app in Android Studio to make a more user-friendly, dynamic and interesting app.

3.12.1.2 IDE: Android Studio

Android Studio is an official IDE for the development of Android Applications. It's convenient in the wealth of code editing, options for visual editing, core app manipulation, and the testing of applications on built-in emulators. Android Studio offers a myriad of libraries and references with thoughtful explanations. Tutorials, help and support are often available for any type of application for an application within Android Studios. The IDE also has built-in functionality for GitHub, the code-sharing the group is comfortable with and can continue to utilize in the project.

3.12.1.3 Devices to Emulate

In order to test the app, the team chose to use not one, but two different devices to make sure that the app looked and worked seamlessly. These two devices were the Pixel 2, and the Samsung S8. There were devices owned by two members of the team, making it possible to test how design would work outside of the emulators. Other device emulators were tested to make sure functionality and appearance

3.12.2 User Interface Research

In order to have a phone application to supplement the instrument, but not be required in the use of the instrument, the team had to decide on features that would give the user a better experience if the user wanted to utilize the application. These application features were discussed among the team as options for enhancing the use of the instrument.

3.12.2.1 Necessary Features

The features mentioned in Table 35 are the base goals the team would implement for the app. So, these features are meant to help a user broaden the possibilities of the device. The app features themselves are meant to be simplistic, as the main project is the device, not the phone application.

Table 35 Necessary Features of the App

Feature	Description
Record	The main allure of this supplemental app is the ability to record what was played on the device. Users can start recording and while notes are being played on the device, the app records what was played for later use.
Change Instrument	This portion of the app changes what was recorded with the app, changing the type of instrument the user hears with the recorded sequence of notes.
Playback	The playback feature allows users to save any instrument changes to the recorded notes into a playable file for devices and allows users to listen to the recorded file with the chosen instrument.

To further explain the basic application flow and the functions, Figure 20 illustrates the generic layout of the application. Upon application start, the home page and a layover menu will allow the user to view saved recordings or attempt to connect with the device. If the user chooses to view recorded files, the user will be given a selection of instruments that are included on the app to choose to listen to the file

with. If the user chooses to connect to the instrument, then the user will wait on a loading screen until a connection exists. Once completed, the user will be given the option to start and stop recording what notes are played when on the instrument. When a recording is made, the user can continue to make recorded files, or go to the playback of recorded files to hear what was played.

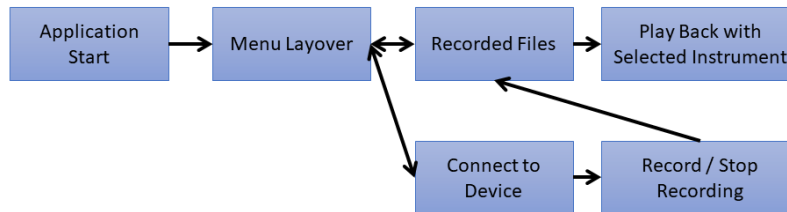

Figure 20 Application Flow

3.12.2.2 Stretch Goal App Extras

These extra features are features that the team wants to implement for a more robust app, but aren't a necessary part of the app. These additional features are time consuming and software-heavy, too much so that they are unlikely but hopeful goals for the final project. There is quite a bit of potential for an application to work in conjunction with the device, especially if the team can master the possibility of changing settings on the device from the application. The most helpful of these would be the option to teach users, even if just as an example of how to use the instrument at first, like a tutorial.

The first additional app functionality would involve a setting to change the device's octave range or app's octave range to give the user the ability to modify the current octave. This functionality will be accessible from the app which will allow a user to utilize the app with one hand and play the instrument with the other hand. A section functionality would be to teach a user a song. This method for learning how to play songs would involve interaction between the app and the instrument. The teaching method would involve the user choosing a song, choosing the tempo. The instrument turns the lasers on and off to show the user when to place and remove fingers to correctly play. This could also grade users based on closely the notes played match to the correct notes of the song.

Another function would be to have the app play a song on the device instead of teaching the user. This function would turn the lasers on and off based on a chosen song. It would also play the song with the chosen instrument on the device through the device's speakers. For users that want more than just the given instruments on the device, users could add files of recorded instrument notes to create an instrument on the app. If there is enough storage on the device, the new instrument could also be downloaded to the device. Given a graphical representation of the

MIDI file, the user can modify the file by adding notes and changing timings of existing notes. This view could instead show the notes on musical measures like sheet music. This would give the user the opportunity to drag and drop notes or to edit the note length.

Table 36 App Stretch Goal Features

Feature	Description
Change Octave	Implement a setting to change octave on device or in application
Teach	Use the app to demonstrate how to play a song on the instrument
Play on Device	“Play” a song on the device by turning lasers on and off while outputting the sound to the speakers
Add Instrument Files	Allow users to add more instrument sounds to the app
File Manipulation	Modify MIDI files in an interactable musical measure

3.12.3 Technology Comparison

For this application, there are two different libraries that are unfamiliar to the team, as they are uncommon to simplistic applications. Luckily, both Bluetooth and MIDI are very verbose libraries. The application will need to utilize both infrequently used libraries within the application.

3.12.3.1 Bluetooth

With the enormous support found in the wealth of native libraries for Android apps, there already exist documentation and references within the site for apps: developer.android.com. The documentation guides explain the settings and permissions necessary to deploying not only Bluetooth, but Bluetooth Low Energy within applications. The documentation covers finding devices, connecting to devices and managing the connection. The only function of the necessary functions that will need this specific functionality of the app will be the recording function. This is due to the device transmitting the MIDI files and any other data from playing the device to properly record the instrument. Both devices chosen to be used for testing with are Bluetooth LE equipped, perfect for testing connectivity with the instrument.

3.12.3.2 MIDI

There are many resources available for MIDI files for Android Applications. Specifications for MIDI files over Bluetooth and Bluetooth LE exist from the MIDI

association, but most details are handled by the already existing libraries for MIDI provided by Android Developers. In the design of the app, MIDI files will be utilized for the recording and playback of the recordings. MIDI files will utilize the instrument files saved with the app, using the instrument of the user's choice. This type of functionality is handled within Android libraries.

4 Design Constraints and Standards

The design constraints and engineering standards listed in this section concentrate on placing limits on the project and upholding the project to certain preestablished guidelines. These aid in the engineering design process by regulating decisions that help to influence the part selection. Creating a focus during part selection will minimize consideration for part options that are unnecessary to produce a final project that meet all goals and requirements. Keeping these in mind help to minimize the project's negative contribution to environmental aspects as well as maximizing the project's functionality potential.

4.1 Constraints

Constraints are the limits that restrict this project by specific margins. These limits help to maintain the projects efficiency while regarding the safety of a user's operation of the laser instrument. The constraints outlined in this section relate to the requirements established previously in this document being that all project aspects must satisfy their specifications. Any constraint or requirement ignored or inadequately executed in any manner will result in the final product being deemed unacceptable. Unlike the engineering requirement specifications that generally focus on the product's development, the constraints emphasize environmental factors related to the product including economic factors, social factors, and health and safety factors. These influences are critical to the consideration of the laser instrument during development as they could impact the user and the environment during operation.

4.1.1 General

The following general constraints are issued by the project team and university, and the constraints are highlighted in Table 37. These constraints impact or are impacted by the overall project.

Table 37 Project Constraints

Constraint	The project shall...
C.P.1	Be designed by January 3, 2020
C.P.2	Be completed in testing and construction by April 20, 2020
C.P.3	Use a portable power source
C.P.4	Feature a custom PCB that adheres to all the project's size constraints

4.1.2 Economic Constraints

Economic constraints apply to the restrictions of the project’s financing as a result of the quality and quantity of components required to produce a feasible product. Economic constraints must be declared such that they allow the team some liberty during the part selection process. Those constraints relevant to the project are outlined in Table 38.

Table 38 Economic Constraints

Constraint	Economic Constraint
C.ECON.1	The project shall cost no more than \$1000
C.ECON.2	The laser instrument shall cost no more than \$700
C.ECON.3	The application shall cost no more than \$100
C.ECON.4	The laser instrument design and cost shall be scalable to multiple copies

4.1.3 Environmental Constraints

Environmental constraints apply to the protection and preservation of the environment which demands recognition and planning around environmental impacts related to carbon footprints, energy efficiency, and reusability. Those constraints relevant to the project are outlined in Table 39.

Table 39 Environmental Constraints

Constraint	Environmental Constraint
C.ENV.1	The project shall refrain from using notably environmentally harmful components when possible
C.ENV.2	The project shall be energy efficient
C.ENV.3	The laser instrument will utilize rechargeable batteries where they are applicable

4.1.4 Social Constraints

Social constraints apply to the accessibility, privacy, psychology, education, and social etiquette of humans. The social constraints in this project pertain to the human interaction with the instrument. Those constraints relevant to the project are outlined in Table 40.

Table 40 Social Constraints

Constraint	Social Constraint
C.SOC.1	The project shall include a display to make the device more user friendly
C.SOC.2	The project shall be designed such that a user can operate the instrument with one hand or two
C.SOC.3	The project documentation shall utilize vocabulary that does not require musical expertise

4.1.5 Market Constraints

Market constraints apply to the ability to retail the product to the largest audience possible. These constraints are important to minimize excluding a potential target audience as a result of marketability. Those constraints relevant to the project are outlined in Table 41.

Table 41 Market Constraints

Constraint	Market Constraint
C.MAR.1	The project shall not intentionally exclude a group from being able to use the device due to difference in hand size
C.MAR.2	The project shall not exclude users that do not have any prior musical experience from using the device
C.MAR.3	The project shall not utilize components banned from production in other countries
C.MAR.4	The project shall accommodate user preference of instrument use via different instrument sounds

4.1.6 Health and Safety Constraints

The following constraints will be implemented to prevent any danger to a user's health or safety while interacting with the laser instrument in any capacity. In this project, lasers will be used to capture user input and are the central driving force of the entire device. As a result, the safety measures implemented with a typical operation of lasers must be considered for this project as well. The health and safety constraints that will govern the projects implementation of laser and other components are highlighted in Table 42.

Table 42 Health and Safety Constraints

Constraint	Health and Safety Constraint
C.HS.1	The lasers shall be oriented in a way that will not emit light in the direction of the user's eyes
C.HS.2	The instrument shall not require the use of safety gear or equipment to operate
C.HS.3	The instrument shall not have any exposed wire or circuitry

4.1.7 Engineering Constraints

Engineering constraints apply to physical aspects that must be considered while designing and producing a frame for the project. Those relevant to the project outlined in Table 43.

Table 43 Engineering Constraints

Constraint	Engineering Constraint
C.ENG.1	The project shall be designed such that each laser diode will not interfere with another
C.ENG.2	The project shall be designed such that the frame accounts for space required for all components necessary to operate the device
C.ENG.3	The material used for the instrument frame shall have the structural integrity required to be used over a long period of time, including but not limited to heat resistance, light reflection, weight, and electrical conduction

4.2 Standards

Several aspects of the team's laser instrument project must adhere to the various standards put in place to ensure safety of construction and operation. Being as this project utilizes various electrical components from PCBs to laser diodes, various standards would directly impact the team's selection process for several components required to develop the laser instrument. These standards also have the possibility of simplifying or enhancing the project's capabilities. Table 44 outlines all the standards covered in the project. In the sections after the table, explanation of the standard and its connection to the project are explained.

Table 44 All Standards

Standard	Name/Field
NASA-STD-8739.3	Soldered Electrical Connections Standard
IPC Standards	Institute for Printed Circuit Boards
IEEE 802.15	Bluetooth qualification
IEEE 802.11	LAN Communication
Android Developers Core App Quality	Application programming quality guidelines
Barr Group	Standards for Embedded C Coding
Agile Development Method	Standardized process for software development
MP3	MPEG-1: 11172-3 and MPEG-2: 13818-3
WAV	Resource Interchange File Format (RIFF)
MIDI	Musical Instrument Digital Interface
ANSI Z136 Standards	Laser safety standards
ANSI C18.2M	Portable Battery Safety

4.2.1 Electrical Standards

The laser instrument will utilize several electrical connections between its internal components, printed circuit board, and physical input devices. In order to maximize safety and reusability, it is important to follow the standards and guidelines set by nationally recognized organizations and community practices. By following these, the final product of this project is expected to improve durability by reducing potentially hazardous events and consequences related to the electrical connections required in this design. The following are electrical standards recognized by, and implemented in, this project.

4.2.1.1 NASA-STD-8739.3

NASA's document on soldering procedures provides an in-depth guide for reliable and safe methods. These methods and standards are geared more towards electronics ruggedized for space. However, these same industrial methods can be utilized to make the project less susceptible to breakage due to rough handling. The team may encounter some aspects of the project that require minor soldering which NASA's standards cover. They are an in-depth analysis in prevention of injury due to safety methods which can be implemented for this project as well.

4.2.2 IPC

IPC, the Association Connecting Electronics Industries, is an association dedicated to standardizing the trade assembly and production requirements of electronics. The organization has numerous standards available for reference for companies and products around the globe. They are well-recognized as a global standard to be held to and is therefore an ideal source for the purposes of this project.

4.2.2.1 IPC 2221

The Institute for Printed Circuit Boards has several standards that apply to the project, but IPC-2221 applies more so than others. This standard is the Generic Standard on Printed Board Design and lays out general requirements for component mounting in the design of a PCB. Other standards created by IPC give detail on safety, design methods, materials, and performance. This project is meant to be a portable device and will need to follow design methods for ruggedized PCB design.

4.2.2.2 IPC 1601

The IPC-1601 standard describes the minimum requirements for handling and storing the PCB in a way that protects the board from contamination and physical damage. This standard will be in effect while the board is transported to the team after ordering, and after the team has received it before assembling into the instrument. Reducing the overall physical damage is the most important aspect of this standard for the purposes of this experiment because the team intends to solder multiple components to the board, and it would be detrimental to the project if the solder connections would deteriorate. If this were to happen, or if the connections were to be damaged some other way, it could cause irregular operations in the device and cause more damage to other components.

4.2.2.3 IPC 4101C

The IPC-4101C standard specifies the acceptable materials to use in the base of a PCB. These are to protect from electric discharge and improve overall quality of a given board. This specifies the weight of the standard board, conductivity, and effect on the environment. While this has less to do with this project than other standards, it is important to acknowledge that the final instrument's PCB will follow this standard to comply with the same requirements as all others.

4.2.2.4 IPC A 620

The IPC- A-620 standard defines the requirements and guidelines for soldered connections made on a PCB. Since the team intends to solder multiple components to the boards, it is necessary to highlight this standard. There are

specific methods to follow to reduce risk and improve connection quality, and the team intends to follow these guidelines to minimize future problems with the board. This standard will provide the requirements necessary to make the PCB used in the final product its highest quality.

4.2.3 Communication Standards

The laser instrument project will utilize wireless capabilities to expand the project's features. The IEEE communication standards included in this section pertain to wireless and networked communication.

4.2.3.1 IEEE 802.15.1

Bluetooth communication is intended to expand the versatility of the project by allowing the user more customizability of the recorded musical notes. The IEEE 802.15 standard applies to the communication between the Bluetooth module located within the laser instrument and a user's cellular phone using an application to record the notes played by the device. The newer version of Bluetooth, using v4.0 and higher to use Bluetooth Low Energy, will be utilized in this project. Bluetooth operates around the 2.4 GHz frequency. The IEEE standard outlines 3 classifications of effective ranges for a Bluetooth module. Class 1 has a range of approximately 100 meters, Class 2 has a maximum operating range at 30 meters, and class 3 has the shortest maximum operating range at just 1 meter.

4.2.3.2 IEEE 802.11

The IEEE 802.11 standard for LAN communication isn't explicitly required so far for the project. However, one of the components does have Wi-Fi capabilities, and in the event the project changes course and has a Wi-Fi connection, then this is a necessary standard. This standard dictates the wireless communication on the 2.4 and 5 GHz bands.

4.2.4 Software Standards

The laser instrument and its connected mobile application must acknowledge and follow multiple software standards set by the community and recognized organizations. This is to prevent errors, bugs, or potentially hazardous events from occurring while the user is interacting with the software. Any situations such as these will hinder the operation of the entire laser instrument device or possibly damage components. These standards apply to the source code as well as the connections managed by this code. The ones specific to this project are listed in the following sections to give their description and how they apply to the laser instrument designed.

4.2.4.1 Android Developers Core App Quality

The Core App Quality guidelines set by Android Developers were created to establish high-quality applications. The guidelines set good user experience expectations and prevent common issues. The guidelines cover a variety of app areas, including standard design, navigation and notifications. Furthermore, the guidelines are set in place to prevent issues with permissions, privacy, and performance on the device.

4.2.4.2 Barr Group's Embedded C Coding Standards

This standard was set in place for coding with C to prevent errors and 'bugs' within code as groups work on sections together. Without set standards for using something as seemingly simple as brackets correctly can create large issues in the code as it is passed from person to person. This set of standards shows examples for all the code standards the group sets. The group will be using C in the embedded systems software, and in order to prevent errors in the project, will be implementing these coding standards.

4.2.4.3 IEEE 830.1998

The IEEE 830.1998 standard outlines the recommended practices and requirements for software. It provides the content and qualities of good software that is to be developed and presented both in-house and commercially. They can also assist in the selection of other products to use during the development process. This standard directly influences the development environment used for the source code of the mobile application used in this project. It also directly influences the design of the application and the communication it has with the instrument. The final product is expected to be presented as a device to be sold commercially, so it is important to follow these guidelines to increase commercial applications and streamline the development process through the duration of this project. Included in IEEE 830 is a definition and description of a recognized "good" Software Requirement Specification (SRS). The following sections define and apply SRS to this project.

4.2.4.4 Software Requirement Specification (SRS)

The role of an SRS is to define what the software being developed is expected to do. This affects the development process, including planning, design, assessment, testing, and expected final functionality and operation. In larger projects, it also includes the interaction between multiple interfaces. For the purpose of this project, there is only the single interface for the user to interact with. The communication is expected to be a single bidirectional path between the mobile application and the instrument, which makes the list of SRS's simpler but still just as important. Each SRS is meant to be referred to during every step of the development process

to confirm that the software is on track and continues to serve the purpose that it is included in the project for.

There are several characteristics of a good SRS, as defined by IEEE 830. The first is that a good SRS must be correct. This means that every requirement listed is one that the final software will meet, and that every market requirement has been met. With this practice, the design of the software in this project will satisfy each applicable requirement defined by the customer and the final software will meet the design specifications. The next characteristic is that an SRS should be unambiguous, which means that it is clear enough that everyone who references it can understand it. This helps to confirm that there won't be multiple interpretations of the same SRS, which regulates the development process between the customer and the developer. The next characteristic is that a good SRS is complete. This means it must include all the significant requirements for the entire project, how the final product will react to expected input, and all the supporting material is completely defined. An SRS must also be consistent, meaning that it does not contradict another SRS or other referencing documents that the project builds from. This includes listed schedules within the project, descriptions of a single part or components, or referenced values used in research or testing. Also, a good SRS must be verifiable, or able to be tested to prove that a specific requirement has been met. It must be modifiable so that when a requirement changes, the software can change in reaction to that. This influences all the other good characteristics of an SRS as well.

An SRS is very similar to an engineering requirement but is strictly limited to the software of a project. In that sense, a list of good SRS's place the software of a project into an environment in which it can be approached as if it is its own project. This is an ideal way to break down delegations of tasks and identify the relation the final software has on the design of the project. Since an SRS presents a solution to a specific problem, it can be used to address specific requirements presented for the entire project and have a lasting impact on the design for the final product. It makes these solutions simpler to track when good documentation is kept, and all ideas presented are agreed upon by a combination of the consumer and the engineering team developing the software.

4.2.4.5 IEEE 829

The standard IEEE 829 defines and explains the proper software testing stages and the documentation required for the process. It is meant to improve readability and reusability when analyzing and citing tests throughout a given project or in future projects by other groups. This is an important standard to apply to this project because the mobile application will require significant testing to be fully integrated with the laser instrument by the end of this project. Each of those tests will need to be repeated several times throughout the development process and must be replicated for demonstrative purposes with the final product. This does not have a direct influence on the design of instrument, or the software used for the

application, but is important for the testing stages of the project. The practices described by this standard can be applied to both software and to the physical device designed. Standardizing the testing processes will improve team efficiency and the trust factor of the tests themselves knowing that they have been properly documented and cited for future references.

4.2.4.6 Agile Development Method

The Agile development method is a growing standard practice used in many development environments today. It is the cycle of communicating with the customer, developing in stages, and being responsive to changes in design or requirements. It increases understanding of needs between the consumer and the development team by setting expectations of regular communication that includes reporting and feedback between the two groups. It also allows for a development team to work in shorter bursts of energy to complete smaller stages of the project, in this case it is the software, before reassessing the design to meet the market requirements. This can be applied to this project easily because the project builds from several similar ideas that have been presented by multiple sources. The solutions signed to solve the problems presented may change as the design of the instrument grows over the course of the project. The design of the mobile application is highly responsive to the design of the physical instrument and is therefore susceptible to higher rates of change than other aspects of the project. The software present in the final product is expected to be significantly different than the first expectation, which is why the team has decided to develop within an agile environment. By utilizing this standardized process, the software will improve its adaptability and the team will lose less time to designing and implementing new ideas. This directly satisfies multiple requirements highlighted in the House of Qualities presented in Figure 4.

4.2.4.7 IEEE 1540

The IEEE 1540 standard relates to risk management in the life cycle of software. By standardizing the way potential problems are identified and the documentation of the consequences of such problems, the process for solving the problems found is made easier. Each member is held to the same standards and problems can be tracked in a simpler way when they are all organized the same as each other. This is important for this project since the mobile application is expected to change frequently throughout the design process for the laser instrument, making it susceptible to many types of errors. These errors can be more readily dealt with the use of this standard.

4.2.5 Audio Standards

The laser instrument designed for this project requires the input of audio files and the output of audible frequencies in the form of musical notes. In order to reduce errored file communication or potentially hazardous audio output, this project must

implement standards set by the relative community and appropriate organizations. This affects multiple parts expected to be used in the design of the instrument and therefore the final functionality of the product. The following are the standards specifically recognized and applied to this project that have direct impact on the design of this project.

4.2.5.1 MP3 (MPEG Layer III Audio Encoding)

A common audio format, MP3 file standards are comprised from MPEG-1: 11172-3 and MPEG-2: 13818-3. Although using MP3 would be in a stretch goal, it is still being listed here. The stretch goal that would require this standard is with the app. If a user wanted to make an MP3 file using MIDI file recordings and an instrument, MP3 files would suffice as a format of file for playback. MP3 files are generally recorded and played at 128 kbit/s for mono sound and 256 kbit/s for stereo sound. It was created by the Moving Picture Experts Group, a group dedicated to the creation of “standards for coded representation of digital audio, video, 3D Graphics and other data” [41]. MP3 uses MPEG-1 and MPEG-2 Layers at much greater compression than the two layers individually. A common audio format, this standard is popular due to low complexity decoding and robustness that allows for error handling in transmission.

4.2.5.2 Resource Interchange File Format (RIFF)

RIFF is a generic format for storing data in chunked containers, used by file extensions such as AVI, ANI, and WAV, but can be used by any file extension for multimedia storage. WAV is a popular audio file format that could be used in the final product of this project. The RIFF standard that WAV follows means that the files are separated and therefore categorized by a designated chunking system. Each file is formatted the same way, making reading and processing the files the same across every system. Every file is required to have a chunk identifier, a length specifier, a variable-sized data field, and a pad byte if the data does not have an even length. This does not improve the quality of the audio itself but does improve the quality of reading and writing the audio files. It also increases reusability across multiple systems and can increase processing speed. This applies directly to this project since one of the technical requirements is to process user input and return audio output in real time. There is greater value to processing speed than there is to audio quality for the purposes of this project and the expected quality of the final product.

4.2.6 Musical Standards

Since the device designed in this project is specifically made to produce musical notes, there is a direct effect from recognized musical standards from the musical community and other organizations. These will have direct influence on how the final product is intended to be operated, and therefore should be considered during the design process for this project. The musical standards and guidelines

specifically identified and followed in this project are listed in the following sections. There, they are described and given a summary of the effect that they have on this project and the expected final product.

4.2.6.1 MIDI (Musical Instrument Digital Interface)

MIDI is a standard published by MIDI Manufacturers Association as a method of representing digital musical data. The main document, Complete MIDI 1.0 Detailed Specification, created in 1996, covers several specifications. Of these, portions of the document that are pertinent include the Standard MIDI Files (SMF) Specification, what is in those files, and communication of those files. There are more details about this standard in 3.8 Musical Instrument Digital Interface.

4.2.7 General Standards

In addition to all the other standards listed prior in this document, there are several standards that do not fall within a specific category. The design for this instrument requires the use of laser diodes, laser-sensing, mobile application, physical input, and custom-designed printed circuit board. This wide range of components and connections host an even wider array of possible standards and practices that could affect the final product of this project. These standards that directly affect health and safety when using the instrument, the expected operation of the instrument, or the design process of the instrument are listed in the following sections. Here they are defined and described, and it is specified exactly how they apply to this project.

4.2.7.1 ANSI Z136 Standards

The American National Standards Institute created laser safety standards to create guidelines for safe usage of lasers. This includes Safe Use in general, to outdoor use, labeling and testing laser diodes, and protective equipment. This project will constrain itself to safe use to prevent hazards by beam or non-beam reasons. These safety measures will be followed to ensure there will be no hazards due to the laser diodes being used on the project.

4.2.7.2 ANSI C18.2M Safety Standard

Being as the project is designed to have portable batteries, battery safety standards will need to be followed. ANSI C18.2M outlines types of materials safe for consumers and for what ratings. Batteries are intended to go through testing before being qualified for use, to ensure that any forces that could act upon the battery won't cause failure. These standards also explain the requirements for recharging to ensure users won't have any potential safety hazards.

4.2.7.3 IEEE 1012

The IEEE 1012 standard describes the processes for verification and validation of systems, software, and hardware. Following the guidelines from this is a way to prove if a completed product meets the requirement specifications it was designed to. This applies to this project specifically to increase the integrity of the final product meant to be demonstrated for a consumer audience. By increasing the integrity and verifying that all market requirements have been sufficiently met, the project can be positively related to others in a similar field for comparison of technologies used and the possible applications of varying designs.

5 Project Design

The previous sections of this documentation focused on establishing the team's initial motivation and goals to accomplish throughout this project, providing boundaries using engineering requirement specifications, constraints and standards, and then utilizing these guidelines with component research to select the most practical parts for the laser instrument project. The Project Design section outlines the compilation and testing of the various components researched.

5.1 Design Process

After identifying the tasks of designing an instrument that utilizes lasers for keys, the initial step for this project was to identify and evaluate the market requirements presented by the client. The market requirements define a portable instrument operated by laser keys that operates with similar functionalities to a standard keyboard. Once the market requirements were established, the features for the laser instrument were defined in order to satisfy these requirements. This involved defining engineering requirements specific to the project that would direct the goals and objectives of the team and shape the final design. With these requirements, a design could be made to satisfy the client.

Based on the market requirements that outline a product satisfactory to a user and the engineering requirements that outline a feasible and functionable project, a list of parts was delineated. This list was developed to ensure the necessary components could be researched and purchased based on how the parts applied to the project and their overall value to the success of the final product. With each part selected and purchased, they could be tested individually before being assembled into the final product. It is important to prove the functionality and limits of a components prior to inserting it into a combined product.

The tests performed in this project were to prove that the device's components would satisfy the marketing and engineering requirements for the project without sacrificing the structural integrity or the quality of its operation. The final list of parts was compiled for pricing and final testing subsequent to the research stage. The final step is to combine all tested components together to verify that they work as intended, and that the entire device satisfies the initial requirements defined by the client in the first step of the process.

5.2 Hardware and Breadboard Testing

To produce a quality laser instrument with accurate performance, the project and its components must undergo several iterations of testing. This section outlines how the team plans to implement and execute various tests for each of the major components researched for the Research and Technical Comparisons section.

The tests chosen were based on the goals, requirements, and constraints the team specified in the previous sections of this document. Based on the diligent examination and comparison for each component type, the team can determine any other parts that would be required to fully test each individual component.

5.2.1 Instrument Frame

The frame must undergo testing to confirm that shape, size, and material meet the requirements to provide a hazardless functioning environment, ample space for components, and a portable design. Testing will occur with both the frame individually and with internal components present. When performing hazardous testing that could be harmful to components, such as water resistance and heat resistance, the frame shall remain isolated to reduce damage that could be done to the other parts. These tests are primarily for the material of the frame to prove that it can withstand potential threats during expected operation. All other tests, where internal components will be present, are to prove that the frame is designed in such a way that allows for full functionality of the other components. This includes but is not limited to the interaction between the laser diodes and phototransistors, battery housing and charging, and secured physical input devices.

5.2.1.1 Testing Single Hand Operation of Instrument

Several requirements and constraints the team previously established for the laser instrument project focus on marketability and maximizing the potential audience for the final product. The project requirement R.P.4 outlined in Table 1 and the social constraint C.SOC.2 outlined in Table 40 both stress the user must have the ability to operate all functionalities of the laser instrument project using only one hand. To satisfy requirement R.P.4 and constraint C.SOC.2, the laser instrument must be able to stand upright in an operational orientation without the assistance of a user. No user assistance would mean the user would not be required to sacrifice one hand to hold or support the instrument in any fashion in order to operate the laser instrument.

To test this functionality, the team would interact with all physical input features on the laser instrument using only one hand. Since the laser diodes and photo sensors do not require direct contact from the user to operate, the physical input features to test with would be any dials, buttons, and switches on the laser instrument. These physical input features should power the instrument on and off, change the output volume of the speakers, and modify note values. These are all basic features outlined earlier in this document by the team and being able to perform these key actions with the laser instrument without a user supporting the frame would satisfy the necessary requirement and constraint.

5.2.1.2 Adequate Spacing for All Components

In addition to the frame needing to be freestanding during utilization, the frame must also have adequate spacing to meet all of the requirements of the laser instrument project. To satisfy the device requirement R.D.1 outlined in Table 2, the maximum dimensions of the laser instrument frame must not exceed 12 inches long, 18 inches wide, and 4 inches in depth. Restricting the frame design to these dimensions would help to reinforce the team's goal to develop a laser instrument with a portable design. While maintaining the dimensions, sufficient spacing between laser diodes must be considered to limit restrictions on hand sizes that can operate the instrument as highlighted in marketing constraint C.MAR.1 in Table 41. A portable design would also insinuate that the frame design must account for space required for all components necessary to operate the laser instrument which would satisfy engineering constraint C.ENG.2 outlined in Table 43.

Meeting the requirements for portability cannot overshadow the team's responsibility to incorporate all necessary components for laser instrument. Considering the operation of the laser instrument intends for a user to interrupt the light emitted by laser diodes with their hand, spacing of the laser diodes is important. Ensuring that the laser instrument's frame allows each laser diode to have a minimum of 1.5 inches between each component would meet the needs of the device requirement R.D.7 outlined in Table 2. It would also warrant that engineering constraint C.ENG.1 outlined in Table 43 would be covered given the spacing between the laser diodes creates no interference with each component's emitting light.

Tests to verify the safety and accessibility of user operation are also important checks the team plans on implementing. The team decided all electrical wiring and circuitry must be contained within the frame of the laser instrument to reinforce safe operation for a user. Implementing design features such as this would satisfy the health and safety constraint C.HS.3 outlined in Table 42.

5.2.1.3 Tests for Requirement R.D.2

In order to satisfy the device requirement R.D.2, found in Table 2, the total weight of the final product must be less than or equal to 10 lbs. Since most of the weight of the instrument is expected to come from the frame, this is mostly a test for the frame's material, design, and density. Tests should still include all components vital to regular operation, but final weight can still be estimated if only the frame is available for specific tests. All tests to satisfy this requirement are simple, needing only a scale capable of holding up to 10 lbs. of weight. The team intends to zero the scale, place the frame and all components necessary for regular instrument operation on the scale, and record the cumulative weight. As long as this record is at or below 10 lbs., this device requirement will be considered satisfied and the product will be considered portable enough to satisfy the market.

5.2.1.4 Tests for Requirement R.D.8

To satisfy the requirement R.D.8, found in Table 2, the frame must be able to allow quick and easy access to the internal components. With whatever method used, the frame must be able to disassemble in less than 20 seconds to the point where the majority of internal components are visible and accessible. These tests only require the frame, with the expected internal component locations marked for reference. If the frame can be broken down to the point that the internal marking can be reached within 20 seconds, this requirement will be considered satisfied and this characteristic of the frame will be deemed appropriate for use in the final product.

5.2.1.5 Tests for Constraint C.HS.1

To satisfy the constraint C.HS.1, referred to in Table 42, the laser diodes must operate under intended use in an orientation that does not shine outside of the defined playing area within the frame. The frame must be able to withstand mild collisions and direct contact with the user without changing orientation. Failure of these tests could prove hazardous to the user if used in the final product. The tests consist of the frame and the laser diodes. With the diodes set in their intended location, they whole setup will undergo a series of mild collisions to simulate a stressful environment that would still be considered expected use. If the lasers continue to shine in the same direction, the frame passes the tests and can be considered satisfactory for using in the final product of this project.

5.2.1.6 Tests for Constraint C.HS.2

The tests to prove satisfaction of requirement C.HS.2, found in Table 42, require the frame and all internal components. The internal components output electric charges that could be harmful to the user, so all tests should be simulations of regular intended use. The team is expected to monitor for electrical discharge or mild currents running through the frame. This would affect the both the user and other internal components' functionality, so this would be a negative characteristic if the frame did not satisfy this constraint and prove to be valid for using in the final product.

In order for the frame material satisfy the constraint C.HS.2, from Table 42, it must not affect the emitted lasers in a way that reflects or refracts light outside of the designated area within the frame. Tests to verify this require the frame, at least one laser diode, and at least one phototransistor. The intended function is for the frame to securely hold the laser diode and phototransistor in place during regular operation of the instrument, so tests should consist of positioning the components in the frame as they would be in the final product. Then, while emitting a laser from the diode, the frame will undergo low levels of collisions, shaking, and changed orientation that could be expected during regular use of the final product. During

these processes the team expects the laser to continuously shine into the phototransistor without hitting the frame. The team will monitor to see if the laser leaves the phototransistor and collides with the frame, and if this collision results in the laser reflecting or refracting in an unintended direction outside of the instrument's playing area. Lasers performing this way are considered hazardous and will be corrected to satisfy the constraint.

5.2.1.7 Tests for Constraint C.ENG.3

To satisfy constraint C.ENG.3, found in Table 43, the frame must be able to support full functionality after extended intended use. The minimum expected lifespan of a single use is one hour, shown as a requirement of the project in Table 2. To prove that the frame can support this, tests must last for a minimum of one hour while stressing the boundaries of the material's durability.

Initial tests should not include components besides the frame itself because the tests will include hazards that could potentially damage the other components. These include submerging the frame in water with an absorbent material inside to check for water resistance, localized heat application to check for heat resistance, and mild collisions to simulate dropping or bumping the instrument. The frame is expected to be intact and able to securely contain all vital components before and after this stage of tests are completed.

The second stage of testing should occur with the frame and internal components together, after the frame has successfully completed the initial stages of testing to prove durability under specific circumstances. The new tests determine if the frame can resist electricity under regular operation and hold other components secure while undergoing mild collisions. They require the instrument to be operated as intended for the frame to undergo intended electrical stimulation. The team will monitor for short circuits, loose connections, and electrical conduction at various contact points that the user may encounter. Once electrical stability has been confirmed, physical stability will be tested by completing the same mild collisions from the first stage of testing. This should simulate bumping and dropping the instrument, and the team will monitor for altered orientation for the laser diodes and loose connections for other components. If the instrument functions the same after one hour of testing, it has passed the tests and has satisfied C.ENG.3.

5.2.1.8 Processes and Expected Outcomes

The following processes outlined in Table 45 and Table 46 will be utilized by the team to execute the above tests. All tests for the instrument frame will be performed using only one hand to demonstrate the laser instrument's ability to be fully operational with additional support. The expected outcomes will be compared to the experimental results to ensure the best quality of the components for the project.

Table 45 Processes and Expected Outcomes for Frame with Contact

Step	Process	Expected Outcome
1	Test if the completed instrument functions as intended with the use of a single hand	The instrument should function as intended even when the user is only using one hand
2	The frame's back panel must be removable within a 20 second time frame	The back panel will be removed, and internal components accessed within the allotted time frame
3	Apply mild collisions to simulate the most stressful expected environment for the freestanding frame	The frame should remain intact and the lasers should shine in the same orientation both before and after the tests
4	Operate the completed instrument as intended and monitor for electrical discharge and laser reflection and refraction	Lasers continue emitting in the same direction during all testing, and no electrical discharge should be detected during regular operation

The process outlined in Table 45 will require interaction from a user similar to normal operation in order to check the frame's durability against a user. The process outlined in Table 46 will not require the same interaction as it checks the frame's durability against the environment and internal components.

Table 46 Processes and Expected Outcomes for Frame without Contact

Step	Process	Expected Outcome
1	Verify there is adequate spacing inside the frame for all components	All components should fit in their correct positions inside the frame
2	Weight the final device on a scale	The device's total weight should be less than or equal to 10 lbs
3	Apply heat, water, and collisions to simulate the most stressful of expected environments and monitor for change in function over time	The frame is expected to hold structural integrity over extended use

5.2.2 Laser Diodes

In order to test the functionality of the chosen red laser diodes, each diode would be tested with a corresponding photo light sensor to confirm the laser diode's emitted light is able to be detected by the photo sensor. Although the laser diodes and photo sensors would be tested at the same time, the focus for the laser diodes'

testing would be to ensure that they all emit light properly with a given voltage, and the team must also check that the light emitted by the laser diode can be detected by a photo sensor. Tests to check this basic functionality may seem monotonous, however the assured coordination between the laser diodes and the photo sensors is the core of the entire laser instrument project. If either component does not seem compatible, it would hinder the project's performance or completely obstruct its entire functioning.

5.2.2.1 Tests for Requirement R.P.1

To satisfy the engineering project requirement R.P.1 established in Table 1, the laser instrument must support a minimum of 8 notes. Being that each note would consist of one laser diode paired with one photo sensor, a set of 8 of these pairs must be fully functional to meet the requirement. During testing, 8 laser diodes would be setup in a parallel circuit using a breadboard and 8 photo sensors would be establish in an unconnected parallel circuit. All should be powered with a common power source of 5 V. The team expects that the laser diodes should all be able to be powered by the same power source along with the photo sensors, and the laser diodes should be able to emit light onto the photo sensors from a minimum of 2 feet away.

5.2.2.2 Tests for Requirement R.D.6

To satisfy the engineering device requirement R.D.6 established in Table 2, the laser diodes must be able to emit continuous light beams for extended periods of time as well as have receivable wavelengths to the photo sensors. The laser diodes would be tested in an environment with ambient lighting and no lighting to ensure each laser diode's emitted light can be detected by a photo sensor regardless of the ambient light levels in the laser instrument's surroundings. The team will be looking for the laser diodes to emit light several feet away from the point of origin regardless of the ambient light levels. The team will also be verifying that the photo sensors can distinguish the laser diodes from ambient light.

5.2.2.3 Tests for Constraint C.HS.1 and C.HS.2

To satisfy the constraint C.HS.1, referred to in Table 42, the laser diodes must operate under intended use in an orientation that does not shine outside of the defined playing area within the frame. They must be able to withstand mild collisions and direct contact with the user without changing orientation. Failure of these tests could prove hazardous to the user if used in the final product. The tests consist of the frame and the laser diodes. With the diodes set in their intended location, they whole setup will undergo a series of mild collisions to simulate a stressful environment that would still be considered expected use. If the lasers continue to shine in the same direction, they pass the tests and can be considered satisfactory for using in the final product of this project.

5.2.2.4 Processes and Expected Outcomes

The following process outlined in Table 47 will be utilized by the team to execute the above tests. The expected outcomes will be compared to the experimental results to ensure the best quality of the components for the project.

Table 47 Processes and Expected Outcomes for Laser Diodes

Step	Process	Expected Outcome
1	Wire 8 laser diodes in parallel with a 5 V power source	The laser diodes should emit light beams that can reach over 2 feet away
2	Wire 8 photo sensors in parallel and connect to the same power source	The diodes should still emit a beam of light receivable by the photo sensors
3	In an <i>ambient</i> lit environment, direct a laser diode onto a photo sensor from 2 feet away	The photo sensors should output a noticeable change in current and/or voltage
4	Repeat step 3 for all pairings of photo sensors and laser diodes	All photo sensors should demonstrate a change in current and/or voltage
5	In a <i>dark/unlit</i> environment, direct a laser diode onto a photo sensor from 2 feet away	The photo sensors should output a noticeable change in current and/or voltage
6	Repeat step 5 for all pairings of photo sensors and laser diodes	All photo sensors should demonstrate a change in current and/or voltage

5.2.3 Sensors and Light Detection

To test the photo sensor chosen for this project, testing must also be done with the laser diodes since their cooperation would be instrumental to ensuring a fully functional project. During testing, the laser diodes and phototransistors would be oriented identical to their final positionings in the frame design, and a voltage source would be used to power both. The team would measure the current and voltage input and output of the photo sensor to monitor the changes as the photo sensor goes from reading only ambient lighting in a room to the direct light emitted room a laser diode. By doing this process, it would represent the readings the diodes and sensors would produce when a user blocks a laser diode's light beam. This would give the team practical measurements to use when implementing current and voltage ranges at which the laser instrument should output musical note sounds.

5.2.3.1 Tests for Requirement R.P.1

To satisfy the engineering project requirement R.P.1 established in Table 1, the laser instrument must support a minimum of 8 notes. Being that each note would consist of one laser diode paired with one photo sensor, a set of 8 of these pairs must be fully functional to meet the requirement. During testing, 8 laser diodes would be setup in a parallel circuit using a breadboard and 8 photo sensors would be establish in an unconnected parallel circuit. All should be powered with a common power source of 5 V. The team expects that the photo sensors should all be able to be powered by the same power source along with the laser diodes, and the photo sensors should be able to detect the light beams emitted from the laser diodes from a minimum of 2 feet away.

5.2.3.2 Tests for Requirement R.D.6

To satisfy the engineering device requirement R.D.6 established in Table 2, the photo sensors should be able to detect interruptions in the beams of light emitted by the laser diodes. The photo sensors must have distinguishable outputs that can be standardized to formulate varying ranges of currents or voltages. These distinguishable ranges would signify whether a note should be played. The tests done in the previous section for laser diodes would have validated the compatible operation of the photo sensors with the laser diodes.

The tests outlined in this section would go one step forward and collect the current and voltage changes of each photo sensor to determine the suitable ranges. The final ranges will be implemented in the code and would decipher whether a note should be played. The team will be looking for significant fluctuation in the current and voltage outputs after a photo sensor goes from reading ambient light to receiving a direct beam of light emitted from a laser diode. The team expects the values to change at least by a factor of two or three to find suitable averaged ranges that signal the start or stop of a produced musical note. A minimal change in voltage when going from ambient light to a laser diode's light beam will also help to discover any malfunctioning components.

5.2.3.3 Processes and Expected Outcomes

The following process outlined in Table 48 will be utilized by the team to execute the above tests for the photo sensors that are to be tested and implemented in the laser instrument project. The most crucial aspect that team will be analyzing during testing is how quickly the photo sensors will respond to any light changes emitted upon them. The angle at which the laser diodes emit light should also be noted as some sensors may have different optimal receiving angles. The expected outcomes will be compared to the experimental results to ensure the best quality of the components for the project.

Table 48 Process and Expected Outcomes for Sensors

Step	Process	Expected Outcome
1	Wire 8 photo sensors in parallel with a 5 V power source	The sensors should stabilize with readings from ambient light
2	Wire 8 laser diodes in parallel and connect to the same power source	The diodes should still emit a beam of light receivable by the photo sensors
3	Orient a laser diode 2 feet away from a photo sensor and direct the laser directly onto the photo sensor	The photo sensors should output a noticeable change in current and/or voltage by a factor of 2 minimum
4	Repeat step 3 for all pairings of photo sensors and laser diodes	All photo sensors should demonstrate the factor of 2 change in current and/or voltage
5	Compare photo sensors readings of ambient light from the beginning of testing to 30 minutes into testing	The photo sensors should not have drastic changes in ambient light reading after testing with laser diodes

5.2.4 Physical Input

The three ‘physical input’ devices used in the device are the rotary encoder for instrument selection, the on/off switch to turn the instrument on and off, and a potentiometer for volume control. All three of these devices will need to be tested to ensure that they work correctly, particularly the rotary encoder and the on/off switch to fulfill requirements and constraints. The steps to testing from the 5.2.4 subsections are listed in, along with the expected output in relation to the corresponding testing step.

5.2.4.1 Tests for Requirement R.P.3

In order to satisfy requirement R.P.3 stated in Table 1, the physical input component of choice, a rotary encoder, needs to be able to communicate with the MCU and tell it the users instrument choice. In order to accomplish this, the rotary encoder will need to be connected to the MCU. At a bare minimum, the two signal pins will need to be connected to the test MCU GPIO pins, one pin to power, one pin to ground. The fifth pin on the rotary encoder is optional if a button signal is decided to be helpful. Once all connections are successfully made, the MCU will need to output changes made from the turning of the rotary encoder. The MCU will need to be able to determine if the turn made was clockwise or counterclockwise.

5.2.4.2 Tests for Requirement R.P.5

To satisfy the requirement set in R.P.5 in Table 1, the power switch must be able to turn the device on and off. This can be tested by using a test circuit with an LED to confirm if the switch fully turns on and off. This test circuit would consist of a power source, the switch and an LED. If the switch is set to on, the LED lights up. If the switch is set to off, the LED is completely off. If the team decides on a more advanced circuit to provide power until the MCU is finished with any processes to prevent any data corruption issues, then that circuit and switch will need to be tested to ensure that turning on the switch turns on everything, and that turning the switch to the off position will tell the MCU to power off once all processes are complete.

5.2.4.3 Tests for Constraint C.MAR.4

In order to satisfy constraint C.MAR.4 stated in Table 41, when the rotary encoder is rotated, the device communicates to the MCU to change the instrument type for the user's preference. To test this, the rotary encoder will need to be connected to the MCU with the minimum pins, the ground, power, and 2 signal pins. When the rotary encoder is rotated clockwise, the MCU recognizes that the encoder moved and moved in the clockwise. When the rotary encoder is rotated counterclockwise, the MCU recognizes that there was movement and that the movement was the counterclockwise direction. The choosing of files and playing of audio would not be required to test the device, only a screen print by the MCU showing that there was movement of the encoder and the direction that movement occurred.

5.2.4.4 Testing Potentiometer for Volume Control

To test the 10 k Ω potentiometer, it will need to be placed in the audio amplifier circuit. Necessary parts to that include the MCU to send an audio signal, the amplifier device, the potentiometer, resistors and capacitors to remove noise, and the speaker. An example of this circuit exists as Figure 18. Once placed in the circuit, when the potentiometer's knob is turned, the volume of the audio should correspond by increasing or decreasing due to the potentiometer increasing or decreasing the resistance within the potentiometer.

5.2.4.5 Processes and Expected Outcomes

To be able to complete the steps for Table 49, a multimeter, the MCU, rotary encoder, power switch, and potentiometer will be required. All components are necessary to test the varying input functionalities of the device. These steps will help to confirm that requirements and constraints will be met within the project.

Table 49 Processes and Expected Outcomes for Physical Input

Step	Process	Expected Outcome
1	Make connections between the rotary encoder pins the MCU and a power source	MCU print gives direction of movement when it occurs, gives example of instrument change
2	Connect MCU to power switch and external power source	Switch allows power to MCU when on, removes power from MCU when off
3	Connect potentiometer in audio amplifier circuit	Potentiometer dial turning affects volume

5.2.5 Display

The light crystal display can be tested on a variety of microcontroller or processors. With the time constraint in mind, light crystal display will be tested using some sort of development board. Naturally, the development board will contain the microcontroller that will be used within this project. The reasoning behind this is that this would allow easier testing and help satisfy requirement and constraints quickly and efficiently. The purpose of the tests is to determine the capabilities of the light crystal display without having to make permanent changes to the hardware. Using breadboard testing, the pin layout and hardware interfacing can be distinguished. To reduce the number of pins needed to drive the display from the microcontroller unit, the display should be interfaced with the I2C protocol. After testing, the goal is to discover the viability of the light crystal display and present the capabilities before the system is fully integrated.

5.2.5.1 Tests for Requirement R.D.3

The project device requirement R.D.3, in Table 2, states that the instrument will contain a graphical display to label each corresponding note to each laser diode. This means that the display will show eight alphabetical letters that will correspond to the eight laser diodes. To test this requirement, the tests will start by crudely interfacing the LCD with the development board. The initial tests will serve to determine if the LCD operates as expected and for testing functionality of displaying characters. The initial test will have the LCD connected directly to the general-purpose input and output, or GPIO, pins on the development board. Once the functionalities are verified, further testing can be done with the I2C protocol. This would allow the display to be driven on four pins instead of sixteen. This part of the testing is vital for the instrument because it will confirm that the display can be driven on less pins and consequently allowing the use of more GPIO pins for other components.

5.2.5.2 Tests for Constraint C.SOC.1

The project constraint C.SOC.1, in Table 40, states that the laser instrument should have a graphical display that can enhance the user's experience. The testing required for this constrain will pertain to the positioning and content of the display within the instrument. The first test will be to orient the graphical display in a way such that the user could see the display easily without strain. This would be trial and error testing to discover which area of the instrument the display will be placed. Another test would include the contents that can be displayed to help users play the instrument better. In this test, the first condition that should be met is that the users are able to distinguish which notes they are playing. This includes programming the LCD to display characters onto the screen and orienting the characters. The goal is to have a display that will easily help the user play the instrument.

5.2.5.3 Processes and Expected Outcomes

The following processes in Table 50 outline the tests that will be implemented and the order in which they will take place. The processes and expected outcome highlight the functionality that are crucial to the operation of the laser instrument device. This serves as a guideline for the team and should cover all questions about the capabilities of the display.

Table 50 Processes and Expected Outcomes for Display

Step	Process	Expected Outcome
1	Make connections between the LCD, MCU, and a power source, then provide the display with the appropriate software	The LCD will output simple characters onto the graphical display
2	Make connections between the LCD, I2C module, MCU, and a power source, then apply the software to the display	Ensure the LCD will function with reduced number of pins and
3	Write the software to display characters	The LCD will output any extraneous characters needed

5.2.6 Audio Output

The process of testing for the audio-related requirements will involve the testing of the received amplifier, speaker, and other related circuitry to produce quality audio for the instrument. The steps of the testing are summarized below in Table 51.

5.2.6.1 Tests for Requirement R.D.5

To satiate R.D.5 from Table 2 the entirety of the audio output circuit will need to be tested separately and alone. This begins with the amplifier. The amplifier will need to be tested to make sure that it is properly taking a wave and increasing the signal's voltage. A test circuit using a multimeter can be used to verify this is correct. The next component will be the potentiometer, which can be tested using a multimeter and testing to verify there is a difference in resistance when the knob turns. Finally, the last part to be tested separately will be the speaker. To verify it will meet requirements, frequencies of increasingly low values will be passed through until there is no longer an audible noise from the speaker or the frequency is 0 Hz. The speaker will then need to be tested to its highest wattage or a comfortable volume to confirm that it can be loud enough for a personal instrument. Once all these parts have passed their expected output tests, then the circuit can slowly be assembled to confirm that the parts work together. The first step will be to connect the speaker directly to the DAC GPIO pin 25 or pin 26 on the MCU. Even if there is faint noise that sounds like the file the MCU is playing, the speaker passes the test.

The next step will be to add the amplifier to the circuit if it doesn't pose the chance of blowing the speaker. The speaker should produce the file being played at a much louder volume. Once that is verified, then the potentiometer can be introduced. If modulating the degree angle of the knob on the potentiometer changes the volume of the audio coming through the speaker, then the main components pass the test for the basic audio circuit. From there, noise filtering methods can be added to the circuit as per the example circuit given in Figure 18 until clear audio is produced by the speaker.

5.2.6.2 Tests for Constraint C.HS.2

In order to confirm that there isn't a way for the circuit to reach potentially damaging levels of sound per constraint C.HS.2 located in Table 42, the audio circuit must first go through the testing listed in 5.2.6.1 and listed in steps 1-3 in Table 51. From there, the decibel response given by the lowest resistance, highest volume, on the volume control will be measured. There are a number of reputable phone apps that can do so for free, and to verify that one phone doesn't have flaws/incorrect results, all team member phones will be used to verify that the level isn't damaging. According to the National Institute on Deafness and Other Communication Disorders, sustained sound of 70 dBA or less is unlikely to cause hearing loss [42]. The expected output of the device at maximum volume is much less than this but will be confirmed by the results of testing.

5.2.6.3 Processes and Expected Outcomes

Table 51 gives the simplified, listed tests to be completed by all audio output. These in-order processes will confirm that the audio will be able to meet the

requirements and constraints designated by the group. For completion of these steps, a waveform generator, multimeter, the amplifier, speaker, potentiometer and the MCU will be required.

Table 51 Processes and Expected Outcomes for Audio Output

Step	Process	Expected Outcome
1	Verify amplifier and speaker work: connect amplifier to waveform generator and multimeter; speaker connected to waveform generator and multimeter	Amplifier increases input analog signal; speaker plays required frequencies of the instruments
2	Verify amplifier and speaker work harmoniously when connected to MCU/audio input	Speaker plays audio file at a loud level
3	Verify entire audio output circuit works	Volume (and possibly gain) works with the speaker and amplifier when connected to an audio input
4	Using completed audio output circuit, find loudest sustained volume using application	The loudest volume in dB to confirm instrument is within constraint

5.2.7 Microcontroller Unit

The microcontroller unit, MCU, can be tested in many different ways. Most of the components will require the MCU in order to operate, therefore the MCU should be tested alongside other component testing. Testing the MCU with other components will give a better idea of what works and what doesn't.

5.2.7.1 Bluetooth Tests for Requirement R.P.6

In order for the microcontroller unit to satisfy requirements R.P.6, located in Table 1, the application and the Bluetooth module must connect successfully. The intended use of the application requires this to work so that the user can give the correct input to control specific features of the product. The tests to check for this functionality consist of the Bluetooth module and the application. The team will monitor command requests for valid responses to confirm that the application can connect to the product's Bluetooth module, validating the use of this part in the final product.

5.2.7.2 Bluetooth Tests for Requirement R.D.9

Similar to the previous tests to satisfy R.P.6, R.D.9 from Table 2 can be tested with just the Bluetooth module, possibly included with the microcontroller, and the

application. The team can connect the two and monitor a series of command requests and replies to confirm that full communication is occurring between the two. A consistent connection is necessary for the full functionality of the final device.

5.2.7.3 Musical Instrument Digital Interface Tests for Requirement R.P.1

The MIDI files generated by the device within the microcontroller must accurately correlate to musical notes to an octave of 8 natural notes and play for the correct length of time and at the correct frequency. The team can monitor the tests to satisfy requirement R.P.1 from Table 1 to verify that this outcome occurs. If the files are not accurate or cannot correctly simulate the notes expected, then it will not be considered satisfactory for use in the final product.

5.2.7.4 Processes and Expected Outcomes

The processes in Table 52 explains the processes that follows when testing the microcontroller unit. A development board could be used to test preliminary testing and viability with components.

Table 52 Processes and Expected Outcomes for Microcontroller Unit

Step	Process	Expected Outcome
1	Verify that the Bluetooth can be connected to the application. Send at least one request and monitor for a response.	It is expected that the microcontroller unit will function as intended and the application will connect to the Bluetooth. A request should receive a response to show that connection has been made.
2	Using the application and components controlled by the microcontroller, send command requests and verify that correct responses are received.	After connection to the Bluetooth, the microcontroller is expected to correctly process and deliver commands, and then return correct responses accordingly. If the application can control the components connected to the controller, it has passed this test and is acceptable for use in the final product.
3	After simulating user input, the instrument must be monitored for the correct audio output from the correct files for the correct time.	It is expected that the controller will process a given command to select a specified audio file and play for a specified duration. If the notes are played as expected, it is acceptable and passes this test.

5.2.8 Battery and Power

The power consumption will be tested after all of the components within the system are decided upon and purchased. Most of the power consumption is determined by the microcontroller chip. Initial testing can be done on the power source by testing it with a development board. The best way to test the power source is to implement it within another component testing. Most importantly, the battery also needs to be tested to make sure that the right electrical characteristics are being output. A multimeter would be needed to operate this test. The battery could solely be connected to the development board and measure the voltage and current being sent to the board.

5.2.8.1 Tests for Requirement R.D.4

The project requires in R.D.4, in Table 2, that the device will have an operational lifetime of at least one hour. To test the battery life before overall system integration, the battery can be tested with the laser diodes and development board to be monitored for approximately one hour. This can give a good estimation of the battery life and help determine if the requirement is fulfilled.

5.2.8.2 Tests for Constraint C.P.3

The project constraint C.P.3, in Table 37, proclaims that the laser instrument will use a portable power source. The portability aspect of the battery would be that it does not require the instrument to be directly plugged into a source of power, such as a wall outlet. The testing of this constraint is very minimal and can be seen by the type of power source that the instrument will utilize.

5.2.8.3 Processes and Expected Outcomes

The following processes in Table 53 describe the processes to take when testing the battery and power source. The battery and power source needs verification with the electrical characteristics and viability with the development board that contains the microcontroller unit that will be used.

Table 53 Processes and Expected Outcomes for Battery

Step	Process	Expected Outcome
1	Power the instrument for a minimum of one hour	The battery will power the device for at least one hour and it will function as intended
2	Operate the instrument as intended using only the portable power source	The instrument will operate as intended and will not require the use of external power sources over the course of at least one hour

5.2.9 Audio Storage

The entire audio storage system, which includes the storage device and the reader or adapter, must be tested to prove the instrument satisfies the engineering requirements of the project. For the user to use the instrument as intended, the audio output must occur in real time with user input. This means the input must be processed, audio file must be accessed, read, and output within certain time limits to simulate a real instrument's playing method.

5.2.9.1 Tests for Requirement R.D.10

To satisfy the requirement R.D.10, which can be referred to in Table 2, the audio files used in the final product must be accessed, read, and output in real time. The goal is to minimize reaction delay between user input and device output, allowing the user to play the instrument just like how they would play any other instrument. The tests for this would require the audio storage device, storage reader or adapter, and at least one speaker. The laser diodes and phototransistors are not required because the input they would supply can be simulated by the controller to increase test accuracy and recordability. Tests will consist of sending the controller the signal to simulate the user input of breaking laser contact with a phototransistor, commanding the audio file to play for the correct duration, and record the exact response time. The team will verify that the cumulative response time is under 150 ms. The expectation is that response time will remain below 100 ms to be perceived as instantaneous according to the popular study [55] done by James Martin, but an extra buffer time could account for cost restrictions for this project. If the total reaction time is within the allowed duration, then the audio storage and retrieval systems have passed the tests and are to be considered suitable for use in the final product.

5.2.9.2 Processes and Expected Outcomes

The following processes in Table 54 describe the processes to take when testing the audio storage device and procedure. It is necessary to verify the overall response time between the user input and audio output, affected primarily by the storage and retrieval of audio files. This encompasses both the physical device used and the procedure defined to process that data after recording input from a given user.

Table 54 Processes and Expected Outcomes for Audio Storage

Step	Process	Expected Outcome
1	Simulate user input and record total response time between the input and audio output	Keep cumulative response time at or below 150 ms. to seem instantaneous to the human brain

5.3 Application

Even as a supplementary portion of the project, the phone application will require testing to conform to required project constraints and requirements. Of these tests, the most important is the ability to connect to the device using the application to communicate MIDI files and similar data.

5.3.1 Programming Environment

Overall app design is to be decided on and created as the device portion of the project develops and the team determines what is necessary. The product of the environment is met by the following sections and outlined by Table 55.

5.3.1.1 Tests for Requirement R.A.1

To test for requirement R.A.1 located in Table 4, the app will need to have functioning code to interface with the BLE on the device. The application will need to find the device, make the connection with the device and then retain connection with the device, and at a bare minimum receive the MIDI files without any corruption. Once this is completed from a short distance of a few inches between the phone with the application and the device, then distance can be measured by continuing to send or receive data and continuing to move away from the instrument while holding the application. With version 4.2 or higher Bluetooth devices, the distance between the instrument and the phone might possibly reach 30 or so feet. This test will be repeated by a minimum of two android phones to confirm that the test for the application isn't device specific.

5.3.1.2 Tests for Requirement R.A.2

To satisfy the requirement R.A.2 as listed and explained in Table 4, the application will need to be able to store the files for notes and play these files per the received MIDI files from the device. To begin the process, the steps in Table 55 from 1-4 must first be completed in order to properly receive the MIDI files from the instrument. Once those tests have completed successfully, then the next steps begin. The app must be able to properly save at least 8 notes of each instrument, and be able to play them from a device, even if not as part of a MIDI file.

5.3.1.3 Processes and Expected Outcomes

To be able to complete the steps of Table 55, the following will be needed: Android Studio to write the application, a program for connecting Bluetooth installed on the MCU, at least 2 different Android devices, and a distance measurement.

Table 55 Processes and Expected Outcomes for Programming Environment

Step	Process	Expected Outcome
1	Application attempts finding instrument	Application finds the instrument as available device
2	Application-instrument connection attempt	Application completes handshake and connection process
3	Application can send and receive files from the instrument	Application receives non-corrupt data packets from the device
4	Phone with application is moved away from the instrument	The instrument and application remain sending and receiving to at least a distance of 3 feet
5	Phone plays instrument notes files saved to application	Phone is able to play 8 natural notes from 5 instruments

5.3.2 User Interface

Overall app design will begin when there is a device to communicate with. Once it is underway, the user side will need to be able to show the user that steps 1-5 are occurring per Table 55. The breakdown of these test to match the events of Table 55 are reflected in Table 56.

5.3.2.1 Tests for Requirement R.A.1

Although the functional programming for Bluetooth interaction for requirement R.A.1 (Table 4) is outlined by 5.3.1, there still remains a user-side of the application to show the results of what is going on. This will be tested by giving the user an update status with the app. This would begin by giving the user the option to select when to search for devices, what devices are available, and then select the instrument as a pairable device. The application then alerts the user to the status of connecting, and when the instrument has connected to the application. Then while distance testing, on the file receiving screen/record screen or on any page of the application, the user is alerted to a bad connection before it breaks the connection. These screens will allow a user to know the status of the connection to allow for clear testing and easier user experience.

5.3.2.2 Tests for Requirement R.A.2

The functional programming requirements in regard to fulfilling R.A.2 were covered by 5.3.1.2, there was nothing covered as far as what the user will see in the process. So, for the user-side of the process of testing for R.A.2, the user will be given a menu option to view all files on the application. Once on that activity, which

is what an application page is called, the user will see all music files for each instrument. The files will be available to be clicked on to play.

5.3.2.3 Processes and Expected Outcomes

The two steps of Table 56 correspond to the following Table 55 steps: Steps 1 and 2 correspond to Steps 1 to 4, and Step 3 corresponds to Step 5. The resources of Table 55 are the same for Table 56: Android Studio to write the application, a program for connecting Bluetooth installed on the MCU, at least 2 different Android devices, and a distance measurement.

Table 56 Processes and Expected Outcomes for User Interface

Step	Process	Expected Outcome
1	Application is completing Bluetooth connections	Application user side displays this happening real-time
2	Application is having distance from instrument measured	Application displays bad connection status to the user
3	Application is having files tested	Application displays all available files, and shows which was played

5.4 Overall Schematic

With the received parts that were discussed in Chapter 3, the example breadboard testing was set up as seen in Figure 21. With an above and angled photo, most of the components are visible. The breadboard layout does show a development board for the MCU (an Espressif ESP32 device). The team has chosen to work with a dev kit while prototyping for easier flashing of programs while testing components. This process will make creating a final program easier while removing risk of potentially destroying the chip with an accidental connection because of the circuit protection provided by the development board.

On the upper, smaller breadboard, there are three components connected to the MCU: a laser diode, a photo sensor, and an SD card reader. For the sake of testing, the laser diode can be powered from the MCU, but the planned design will involve using a decoder to power on specific diodes. Even though this isn't a required feature, the team doesn't want to remove the possibility of choosing only specific lasers to be on but not use a total of 8 pins from the MCU. The photo sensors will all be connected to the ADC pins on the MCU, as shown in the example layout. The pinout from the SD card reader was also matched to the correct pins for an SPI connection to the MCU.

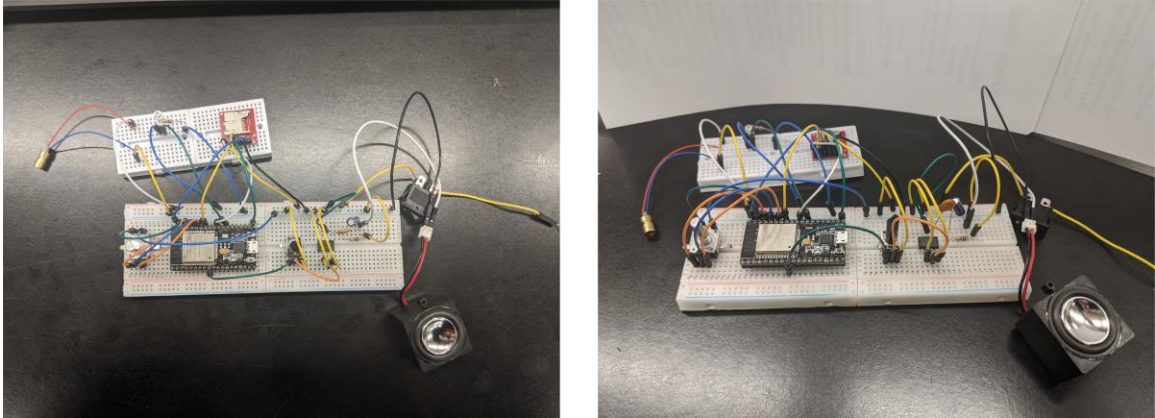

Figure 21 Example Layout on Breadboard

On the larger breadboard, starting from the left is the rotary encoder without the knob. Next is the development board for the ESP32-WROOM-32 chip. For the final design, only the chip itself will be used, not the development kit. The right half of the lower, larger breadboard in Figure 21 is the audio circuit, consisting of the potentiometer, the audio amplifier, and the testing speaker. This set of components receives the audio waveform from the DAC pin on the ESP32 chip, and doesn't require an external DAC device for audio, like some chips would require. The last component is the rocker switch. The unattached jumper on the switch would be connected to a power source for testing. For the photo, there isn't a connection as there was no testing occurring at that moment and the image is meant as a representation of planned testing.

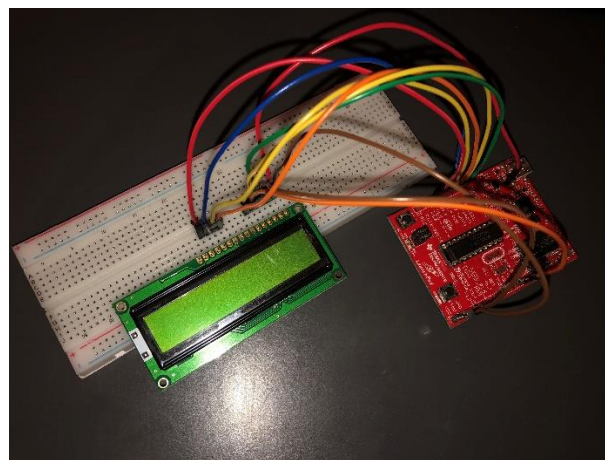

Figure 22 Example Layout of LCD

Regarding a graphical display, Figure 22 shows the testing breadboard layout of the LCD attached to an MSP430G2. Although the ESP32-WROOM-32 will be

used in the final build, the MSP EXP430G2 was used for testing due to availability of the ESP32 development board. In the figure, the pins were connected directly to the LCD. Ideally, the LCD will be connected to an I2C interface adapter that will reduce the number of pins to four in the final build. However, steps are being made to verify compatibility.

5.5 Software Design

The software for the device will be written in C and follow the flow seen in Figure 23. The language chosen was due to the decision to use the ESP32-WROOM-32D in the instrument to handle both the Bluetooth and processing. The general flow of the software within the chosen MCU once turned on will automatically choose an instrument to start with, such as the piano. The instrument will then wait for one of two types of input: a diode beam change or an instrument change.

If there is a beam change, then instrument will need to start to play the corresponding note or stop playing the note. To accomplish playing, the file will need to be fetched within storage, whether that is in MCU memory or in the external audio storage device. This audio file will then need to be looped properly as it is played through the audio circuit. If the note needs to be stopped based on the output of the photosensor, then the MCU will no longer play the note over the audio circuit. With this change, the MIDI file giving instructions on what to do will need to be created, especially if there is communication with a phone application.

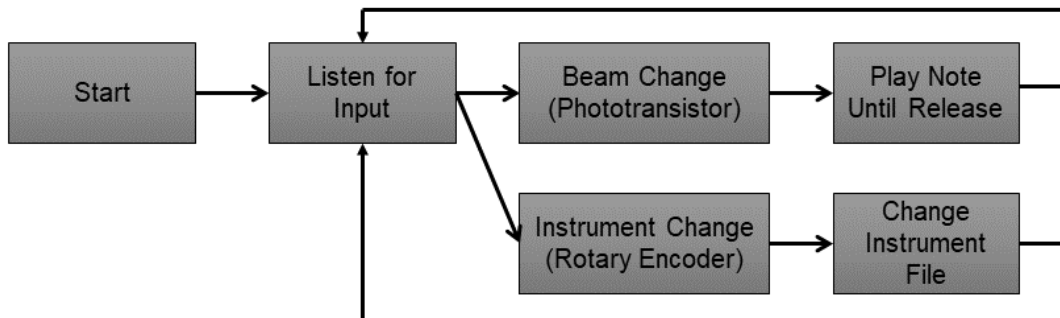

Figure 23 Software Flow

If there is an instrument change, due to the rotary encoder knob being turned in either direction, then the LCD display will need to be updated to show the user the current instrument that has been selected. Upon a final selection (using the button on the rotary encoder), the MCU will need to go fetch the specified files from the long-term memory to short term memory to quickly execute any notes the user chooses to play. A large portion of the important code will be encoding the MIDI files from the phototransistors. Although this is available online, conforming it to the group's needs might prove difficult. Furthermore, the code will contain

communicating the MIDI files to the app via Bluetooth. The team will be following Barr Group's Standard for Embedded C coding while writing the software for the device.

5.5.1 Software Tests

To conform to the requirements and constraints dictated by the group, the following tests will be needed to ensure the software on the will work as stated. The software for the chip will need to be robust and correctly conform to many requirements for the project. The software for the ESP32 chip will need to perform many duties and will need to do so efficiently to fit constraints and requirements.

5.5.1.1 Software Tests for Requirement R.P.1

In order to meet the requirement R.P.1 Table 1, the software will need to be capable of several tasks that are the basis of the whole project. The first will be powering the laser diodes and reading the phototransistors values from the result of the beams being broken. Once the software readouts prove a threshold or some method of differentiating ambient light from laser light shows the beam being broken and unbroken, the next step begins. Which is using that data to create proper MIDI files using the eight natural notes of the selected instrument. To confirm these files are correct, the files will be downloaded and attempted to be played on a computer with proper MIDI reading software. Then, comparing the notes played on the instrument recorded by video to the output from playing the MIDI files on a computer, the team can verify that the files are being created successfully. Then, using the MIDI files, the audio can be tested. The next test will be playing the files using the recorded notes from the instruments to play what is being played by the instrument.

5.5.1.2 Software Tests for Requirement R.P.2

To accurately stay within requirement R.P.2 from Table 1, the notes from instruments will need to be saved to non-volatile memory within either the chip or the audio storage. The note files will need to be verified before they are loaded to memory. Once in the memory, to test that all notes are correct, the team will use the LCD and the audio circuit to play all notes on the audio circuit and show the note file name being played on the LCD. The group can then confirm the right files are being played, only natural notes, with a minimum of 8 per instrument.

5.5.1.3 Software Tests for Requirement R.P.3

In order to satisfy requirement R.P.3 within Table 1, the software will need to host and play the notes from a minimum of five different instruments. The testing method will require the audio system working along with the LCD for readouts. From there, the testing will be done by playing each instrument note and verifying

that notes from different instruments sound different. The LCD will be used in verifying the instruments as the notes are played.

5.5.1.4 Software Tests for Requirement R.P.6

With the demanding task of filling requirement R.P.6 found in Table 1 comes the test of verifying Bluetooth works within the MCU to connect to a mobile application. This step will require the working application from the testing mobile device. To begin, the software will use the Bluetooth LE functions to broadcast itself for the application to be found. Once the phone app chooses to connect, then the software will need to be able to connect properly with the app. Once that is done, the MCU software will need to maintain the connection and properly send data to the app, especially needing to correctly send MIDI files.

5.5.1.5 Software Tests for Requirement R.S.1

For requirement R.S.1 located in Table 3, software for the MCU will need to be able to take the sensor information and play the corresponding note file with negligible delay. Before testing, all software will need to be optimized to ensure that all files being fetched from memory will be the most effective way. To test this, the lasers, sensors and audio circuit must be tested and working. When covering a sensor/preventing a laser diode from reaching the sensor, the MCU must communicate the correct file from memory and play it on the audio circuit. If the MCU can do this fast enough that the time difference between the beam being broken and note being played isn't noticeable and won't affect instrument use, the software will pass the requirement.

5.5.1.6 Software Tests for Requirement R.S.2

Although exactly what will be displayed on the LCD hasn't been decided, requirement R.S.2 from Table 3 demands that information is displayed on the LCD correctly. To begin the testing, the LCD connection will need to be verified. This will be done by printing test statements to the LCD and verifying that the results are correct. Once completed, the testing will begin. Much of the desired display information will be showing the instrument and the notes the beams represent. To do this, changing the instrument by rotating the rotary encoder will change the instrument name displayed on the screen, and the notes that are corresponding to the laser beams.

5.5.1.7 Processes and Expected Outcomes

The following table, Table 57, lists the steps for ensuring that the software loaded to the MCU correctly passes all tests involved with communicating with physical device. Most of the tests require the entire instrument to ensure full command over all components from the MCU.

Table 57 Device Processes and Expected Outcomes for MCU Software

Step	Process	Expected Outcome
1	Verify laser output and sensor input is correct	Software outputs a readout correctly saying what notes are played when
2	Create MIDI files from the sensor input	MIDI file creation mimicking notes played correctly
3	Play audio of corresponding beam and output to the audio circuit	Notes are played through audio circuit when laser beams broken
4	Save the audio files and play them	MCU plays eight notes per octave per instrument through the audio circuit
5	Play the audio files of five different instruments	Different sounds for different instruments

The steps outlined in Table 58 are related to testing communication between the MCU and the mobile application.

Table 58 App Processes and Expected Outcomes for MCU Software

Step	Process	Expected Outcome
6	Broadcast Bluetooth for connection	Phone can see the device as something to pair to
7	Connect to phone application	Phone can pair successfully
8	Send data, testing with MIDI	Phone receives playable files
9	Break a beam connection, note time between the occurrence and the note played	The notes are played with negligible time delay
10	Change instrument/rotate rotary encoder knob	Instrument name on LCD changes accordingly

6 Overall Integration

The Overall Integration section features the final system testing and design for the laser instrument project. Based on the goals, requirements, constraints, selected parts, and component testing performed, the team combined all the information to produce a final breadboard diagram to test all the electrical components in the system simultaneously in addition to a PCB schematic that will be developed for the final product.

6.1 System Testing

The electrical components and functionalities of the laser instrument project can be broken down into 4 subsystems. The first subsystem would be the laser keys of the instrument composed from laser diodes and photo sensors. The team chose to implement red laser diodes with phototransistors based on research conducted in the Research and Technical Comparisons section. The second subsystem would be composed of any physical components that receive input from the user such as switches, buttons, and dials to change the power state of the device as well as the volume and instrument type produced. The third subsystem involves the components that produce outputs for the user. These two parts would be the LCD display that provides note information and the speaker that produces the audio of the device. The final and fourth subsystem remains any component pertinent related to power regulation and decision making. These components are the MCU, which includes Bluetooth and Wi-Fi capabilities, in addition to the battery and the voltage regulator.

During system testing, the compatibility of each component with the entirety of the system is being observed instead of the verifying the component's individual functionality. For the first subsystem with the red laser diodes and phototransistors, their compatible operation was tested in previous sections, so the other components need to be able to manipulate the phototransistors' readings from the laser diodes during system testing. The specific ranges of output voltages from the phototransistors will be determined during system testing to ensure optimal and differential ranges at which the device will use to select the appropriate MIDI file to play. The second subsystem testing will be looking to see that the physical inputs perform their designated functionalities properly. The power switch must safely supply and close of power from the battery to the MCU without damaging any components. For the third subsystem, the team will be checking to make sure to LCD and speakers are outputting the correct information. The LCD should be updating the notes displayed in real-time based on the physical inputs manipulated by the user. The speakers should be producing the correct correlating MIDI file according to the laser diode blocked by the user's hand. The fourth subsystem will be monitored to ensure all components are powered correctly throughout the full operation of the laser instrument.

6.2 PCB Design

The printed circuit board (PCB) used for this project has been designed with the intention to minimize the need for future redesigns and increase adaptability. This increases the chance that the first board tested will work correctly for the purposes of this project. The less attempts that the team needs to make to design an acceptable PCB, the less time and money is wasted before the creation of the final product.

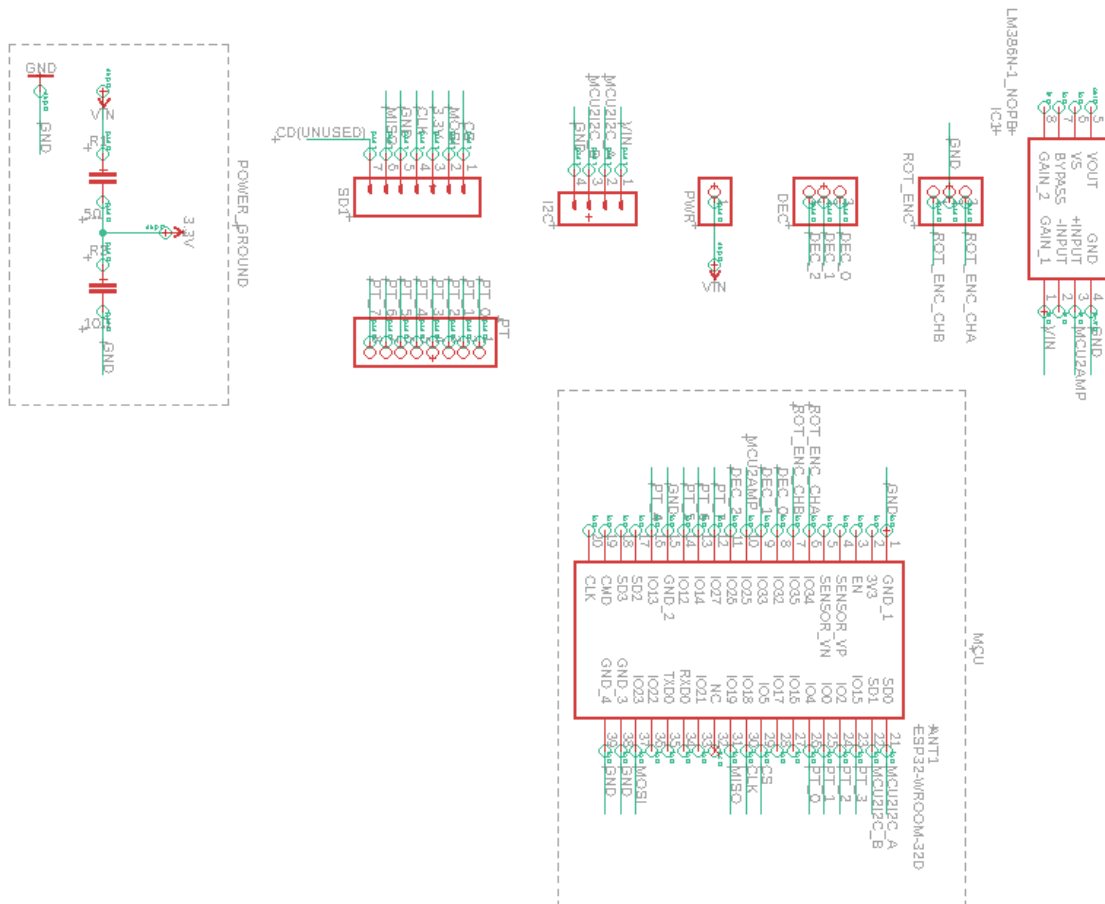

Figure 24 PCB Schematic

Most of the components on the board use through-hole connections for the pins instead of surface mount connections. This is intentional to allow the components to be swapped out if different components are deemed more appropriate for use in the designed instrument. This also allows the majority of the components to be mounted in more remote locations in the frame by connecting wires to the through-holes instead of the component pins directly. By moving the components further from the actual board, they have the possibility to take up less space by changing

orientation and fitting them into specially designed slots in the frame. Also, using through-hole instead of surface mount allows incorrect pins to be more easily swapped if necessary. While the expected outcome is to only need one PCB, it is important to plan for mistakes or problems such as incorrectly mapped pins that can be fixed with through-hole connections.

The board has multiple organizational headers added to it to make mapping connections of off-board components more understandable. Instead of leaving pins as they are on our MCU for example, the pins required by the micro-SD reader have been labeled and connected on a single header that is mapped to the MCU, power, and ground. This will save time when assembling the board and make it easier to modify connections if needed in the future. An example of the final component connections can be found in Figure 21.

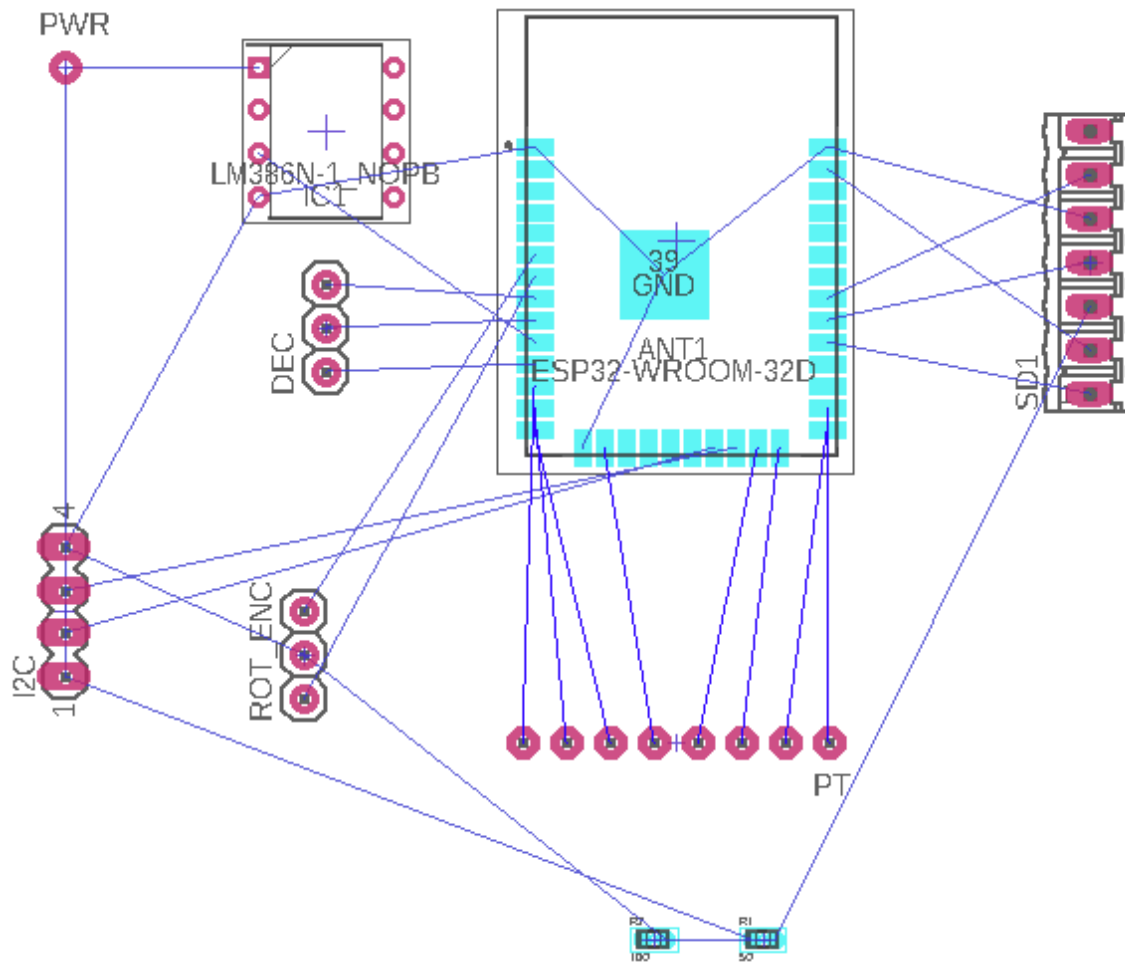

Figure 25 PCB Layout

Figure 25 shows the actual layout that is expected to be used on the physical board. It is intentional that the MCU, labeled as “ESP32-WROOM-32D”, has no components above it. This is to reduce interference with wireless connections that the MCU has built in such as antenna, Wi-Fi, and Bluetooth. Other components are spaced out as they are for organization and to minimize the overlap of net lines. This is not the final layout and will need to be updated once part testing has been completed, but this is close to the expected setup for the final product.

The MCU has the most connections, as that will be the component reacting to and controlling all other components on and off the board. Most other symbols shown represent headers that will improve time and design efficiency while tweaking the instrument during final testing stages. What is not shown, but can be expected in the final product, is that the PCB will have multiple layers. The back layer will be a ground plate to make the multiple electrical connections to ground simple, therefore saving space. The increase in price for multiple layers is minimal and the improved efficiency it provides will make the stress on budget goals worth it.

6.2.1.1 PCB Tests for Constraint C.HS.2

The PCB has been designed with consideration to the safety of the user. To satisfy the health and safety constraint C.HS.2, listed in Table 42, the PCB must operate normally without the need of any safety gear. The PCB is intended to stay inside the frame of the instrument, but it could still discharge electricity or overheat, so it requires measures to be taken to prevent these hazardous events. The board includes circuits to prevent over-voltage events, and tests are to be conducted to confirm that overheating will not occur during regular operations. These tests require the use of all components, the board itself, and the frame. By operating the instrument for as long as the battery(s) will allow, both while and while not charging, the tester will monitor for overheating, short circuits, and electric discharges.

The first stage of testing will be conducted while the power source is not charging. Also, the tester is required to wear rubber, or some other non-conductive material, gloves. Once the batteries have been charged to a full state, they will be unplugged, and the power switch mounted in the frame will be switched to the “On” position. Once the instrument is on, the tester will operate the device randomly. This consists of playing notes in random combinations, dropping the instrument, and changing the audio type and volume. A thermometer and a multimeter will be connected to the frame in the locations where the user is expected to have the most contact. The instrument will fail this stage of testing if the thermometer rises by more than 5 degrees, or if the multimeter records an increase in current of more than 5 amperes. If either of these events occur, the instrument is not functioning as intended and should be redesigned with more safety measures.

The second stage of testing will take place while the battery(s) is recharging. The instrument must be able to function regularly while it is recharging for future use, and this is the only other expected source of power for the final product. The same

precautions and procedures as the first stage of testing will be in place for this stage. Safety equipment will be used, devices will measure for hazardous events, and the instrument will be put through a series of random experiences to simulate the boundaries of expected use until the battery(s) is fully charged. If no hazardous events occur, the PCB can be considered safe for using in the intended final product that a user will interact with.

6.2.1.2 Processes and Expected Outcomes

The following table, Table 59, contains a simplified form of the listed tests for the PCB to satisfy constraints and standards. It also contains the expected outcome of each of the tests. A failure to meet the expected outcome is to be considered a failure to meet the criteria needed for use in the final product and will therefore result in a redesign of the PCB.

Table 59 Processes and Expected Outcomes for PCB

Step	Process	Expected Outcome
1	Operate the fully assembled instrument with random combinations of input to stress the boundaries of intended final environment(s). Record the temperature and current of the locations where user contact is expected to be most common.	The recorded temperature will not rise more than 5 degrees between the start and finish of the test. The recorded current will not rise more than 5 amperes between the start and finish of the test.

7 Administrative

The administrative section consists of the budget and materials for the project, milestones set by the team to adopt a consistent working timeline, and a description of communication methods used during the project's research and design process. Highlighting these specific aspects of the project are important to recognize the project managing parts of this design process. Considering the costs and available finances for the project in the early stages of the engineering design process can alleviate various complications later in the project. Several of the components researched had various options that ranged in unit prices, but the most expensive option was not always necessary for the scope of the laser instrument project.

7.1 Budget and Bills of Materials

The information in Table 60 illustrates the team's allotted costs for the various categories of components required for the project. These established budgets guided the team members in the part selection process and assisted in containing all project related costs within their predefined constraints Table 60 Project Budget.

Table 60 Project Budget

Item	Price (USD)	Quantity	Subtotal (USD)
Frame	\$50.00		\$50.00
PCB Print	\$30.00	1	\$30.00
Photo Sensors		8	\$30.00
Laser Diodes		8	\$30.00
Battery/Power	\$20.00	1	\$20.00
Audio Output	\$10.00	2	\$10.00
Dials/Switches	\$5.00	4	\$20.00
Bluetooth Module	\$10.00	1	\$10.00
Display	\$15.00	1	\$15.00
MCU	\$10.00	1	\$10.00
RLC components			\$30.00
Rotary Encoder	\$5.00	2	\$10.00
Memory Card	\$5.00	1	\$5.00
Total			\$270.00

The Bill of Materials listed in Table 61 lists the current parts, their quantities, and their subtotal cost to develop a single laser instrument device. These parts and quantities were selected based on the research and testing outlined throughout this document. Not all components listed, such as the frame hardware and PCB print, are finite price points as they will be acquired next semester. Thus, these numbers could slightly deviate from what is listed in the table as the team begins prototyping the laser instrument in the coming semester.

Table 61 Bill of Materials

Item	Budget Item	Unit Price (USD)	Quantity	Subtotal (USD)
Frame Hardware	Frame	\$30.00	1	\$30.00
PCB Print	PCB Print	\$30.00	1	\$30.00
SGT5516GK Phototransistor	Photo Sensors	\$0.21	8	\$1.68
HiLetgo 5V 650nm 5mW Red Dot Laser	Laser Diodes	\$0.55	8	\$4.40
5V Power Source	Battery/ Power	\$20	1	\$20.00
Mouser Power Regulator		\$1.81	5	\$9.05
Speaker	Audio Output	\$3.42	2	\$6.84
Mouser LCD		\$10.75	1	\$10.75
ESP32-WROOM-32D	MCU, Bluetooth Module	\$3.80	1	\$3.80
Audio Amplifier	Audio Output	\$2.51	1	\$2.51
Rotary Encoder	Dials/ Switches	\$4.50	1	\$4.50
Potentiometer	Audio Output	\$0.84	1	\$0.84
Power Switch	Battery/ Power	\$0.81	1	\$0.81
Mouser MicroSD	Memory Card	\$4.50	1	\$4.50
Total				\$129.68

7.2 Milestones

Table 62 outlines the key deadlines that the team would work towards to ensure the success and completion of a working project. In addition to the hard deadlines set by the customer which are the professors, the team included more checkpoints in-between to promote a steady work pace and prevent falling behind. Having set goals assists in promoting delegation of tasks that are most significant to the project and reduces indefinite aspects that would be perceived as having too wide of a scope to tackle for the project.

Table 62 Project Milestones

Objective	Start	End	Status
Senior Design I			
Initial meeting	8/30/19	8/30/19	Complete
Brainstorming ideas	9/2/19	9/20/19	Complete
Divide and Conquer I	9/16/19	9/20/19	Complete
Divide and Conquer II	9/20/19	10/4/19	Complete
30 Page Documentation	10/4/19	10/18/19	Complete
60 Page Documentation	10/18/19	11/1/19	Complete
100 Page Documentation	11/1/19	11/15/19	Complete
SD1 Final Paper	11/15/19	12/1/19	Complete
Senior Design II			
1st prototype	10/20/19	1/10/19	N/A
2nd version	1/10/19	3/13/19	N/A
Final Design	3/13/19	4/17/19	N/A
Final Paper	1/10/19	4/17/19	N/A

7.3 Communication

Quality communication is an integral component for a team to succeed. In addition, every member of the team for this project values good communication skills as an ideal trait in a teammate. The team for this project utilizes several communication methods, each serving a unique but equally important function. All team members participated in regular face to face meetings every week, regularly communication

via text and voice chat through Discord, shared files across OneDrive and Google Drive, and utilized version control through GitHub.

7.3.1 Discord

Discord is a free propriety software that is easy to use and provides a great method of communication via voice or text chat while also providing features such as file sharing. The team used Discord text channels to organize general chat information, team meeting notes and delegations, a real-time bill of materials reference, and several other channels used to organize communication and increase efficiency.

In addition, Discord voice channels were used by members of the team to participate in meetings from remote locations. Irregularly scheduled meetings also took place by all team members through Discord voice channels to minimize time lost to travel and quickly communicate information for the project.

7.3.2 OneDrive

OneDrive is a free file hosting service and synchronization service by Microsoft. The team chose to utilize this service to share project files since Microsoft Word and PowerPoint were the chosen software for documentation creation. OneDrive allows online or offline edits of all shared files from all device types which allows the team to make quick edits and incorporate innovative ideas quickly. OneDrive and Microsoft Office products also allow for multiple users to modify documents simultaneously to promote group collaboration.

The team used OneDrive to store all shared files relating directly to the project. This included but was not limited to this paper, all referenced figures, diagrams, and tables, referenced standards, and an ongoing bill of materials. These files were updated frequently by multiple members of the team, making OneDrive the ideal communication tool to share live updates amongst other members of the team.

7.3.3 Google Drive

Google Drive is a free cloud storage option, similar to OneDrive, that simplifies sharing multiple files between multiple users. The files in the team's shared Google Drive were used as references for the project but were not applied directly to the project's documentation. This included but was not limited to tutorials, examples, and ideas that were used or modified for use in the project. For example, when storing and reading audio files and outputting to a speaker, it was useful to refer to an existing tutorial where this had been done before so that the team could minimize the time spent testing incorrect setups. By following the guidance of these

references, the team minimized the design time of the project, which was one of the engineering requirements established at the beginning of the project timeline.

7.3.4 GitHub

For version control, the team plans to utilize GitHub while creating both the software on the MCU and the application. This helpful cloud application will be useful when project members want to work on different sections of software simultaneously. This also allows for backup versions of code in the event of widespread issues or accidental deletion.

The team used GitHub as the storage location for all code used on the MCU and the supporting mobile application. Storing files on GitHub was useful for keeping a functional version of the project's software in a universal location. An additional feature that GitHub provides is version control which allows users to review previous saves of software, and previous versions can be restored if a situation requires a reset. Also, by using GitHub's verification features, a team member was unable to update the state of the project's code without the approval of another team member. This improved communication between members and decreased the chances of breaking the functionality of the project at any point.

The use of GitHub also increases accountability between members, as each change applied by an individual is signed by their account. All team members remain restricted to their own branches of the project and each change a member makes is publicly available for the other members to see. This expedites the process of recognizing errors and approaching the correct member to assess and fix the issue if needed.

The separate branches of development also allow simultaneous work to be done without drastically affecting another member at a given time. Multiple requirements for the source code can be satisfied at once by blocking the portions of the software and isolating portions under construction. This reduces wasted time and improves quality by allowing members of the team to apply their focus to specific areas of expertise.

7.3.5 Face to Face

Regularly scheduled face to face meetings establish a regular deadline and keep every member of the team up to date on the state of the project. By imposing a deadline, regular meetings hold members accountable and verify that each member has seen information and been made aware of what needs to get done by the next deadline.

The team held weekly face to face meetings. During these meetings, the team discussed what had been done the week prior, what needed to be fixed from that

completed work, and what needed to be done for the upcoming week. This improved each member's understanding of the state of the project and held each other accountable. It provided a regular time to ask questions and clarify misunderstandings and set up time to work for the upcoming week. The team also held irregularly scheduled meetings when more work needed to be done, and to provide ample time set aside for member to cooperate with each other and help with delegated work across multiple sections of the project.

These can also be referred to as scrum meetings, which is a reference to the agile development process utilized for all stages of this project. The agile process places focus primarily on function over form, meaning a working product is more important than meeting a hard list of demands. The implementation of this development process allowed for increased growth and adaptation of the design of this project. By meeting more often to delegate tasks and assess the state of the project, the team was able to analyze the changing requirements and adapt the design of the final product more easily before making frequent design changes to meet the new requirements. This is a common practice in today's development environments and was a simple process to adapt for the purposes of this project.

8 Project Summary and Conclusion

Over the course the semester, the team has diligently worked using the engineering design process to research and design a laser instrument device. The major hurdles the team faced through this process included learning PCB schematic development and applying this knowledge with the component research to design schematics, understanding individual electrical components and how they can impact or assist with other parts, and acquiring individual component's schematics. Through careful and consistent planning, the team was able to overcome all major obstacles and meet every milestone or deadline for the semester.

For the laser instrument project, the team designed a device that mimics the basic functionality of an electric keyboard, however the laser instrument will be implemented with laser diodes and photo sensors instead of physical keys to be pressed. Based on if the user blocks the photo sensors, which are phototransistors for this project, from receiving the light emitted from red laser diodes, the device will output corresponding MIDI file that could be from one of these 5 instrument types: piano, string, woodwind, brass, and percussion. The device will include rotary encoders, potentiometers, and switches as the physical input components users will be able to manipulate to modify the device's power state, volume, instrument type, and octave level. An LCD display mounted on the front of the laser instrument will be used to show information such as the current note value and octave level for each laser diode. An MCU component in the device will allow wireless communication with a mobile application to allow recording capabilities as well as modification of recorded data.

The frame that will house all internal components will be prototyped using Styrofoam and the upgraded to a plastic material for the final implementation. The team select a basic frame design for the purposes of this project. Utilizing a more customizable material like Styrofoam during the prototyping phase will allow the team to make quick modifications to the frame as the design is finalized. The Styrofoam would not be durable enough for a final product, so a plastic material will be used to develop the final frame using the latest dimensions the team procures.

As the team finishes the integrated testing phase of the project, several aspects during the prototyping phase that could result in failures must be considered. The next few weeks will be spent solidifying part selections and finalizing integration testing to prepare for the first prototype's implementation. This is expected to happen after the approval of this project, determined by the submission of this document as a proposal. The outlined processes in the breadboard testing section of this document will be followed to evaluate and confirm each part is suitable for the needs of the project. The results during the testing will be compared to the expected outcomes of each process. This will create a minimum standard that the team seeks for each part and will determine the suitability of the part selection.

In addition to verified testing of all purchased components, the team will begin devolving the accompanying mobile application. This document provides goals and guidelines for what the team strives to produce for a mobile application including all basic features and stretch goal features. Most of the application's functionalities are dependent on the core system of the laser instrument device, so early application testing will be done with the assumption that the device can efficiently operate based on user input and receives the correct MIDI file to play. Without any confirmed functionality of the device, the team can proceed with developing all front-end features of the applications and ensuring those aspects work correctly prior to adding the more complex aspects.

9 Appendices

9.1 Copyright Permissions

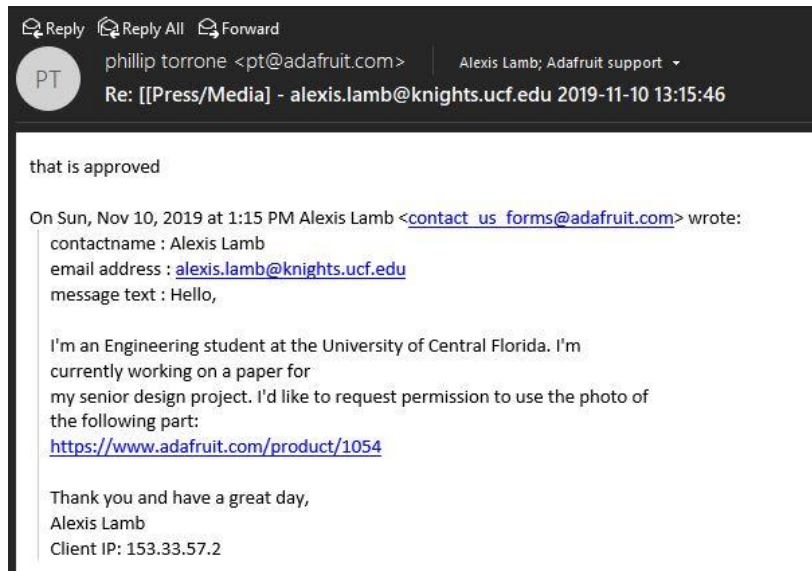

Figure 26 Adafruit Red Laser Diode Permission

Product details inquiry from Amazon customer Krystyn Wikoff(Order: 113-0435696-6329810)

Send To: [HiLetgo](#) 19:26 10/28

Hello,
I'm an Engineering student at the University of Central Florida. I'm currently working on a paper for my senior design project. I'd like to request permission to use the photo of the following parts I ordered:
HiLetgo 20pcs 5MM Photodiode Photosensitive Diode Light Sensitive Diode Round F5 Photodiode 3V
HiLetgo 10pcs 5V 650nm 5mW Red Dot Laser Head Red Laser Diode Laser Tube with Leads Head Outer Diameter 6mm

Thank you and have a great day,
Krystyn Wikoff

Product details inquiry from Amazon customer Krystyn Wikoff(Order: 113-0435696-6329810)

From: [HiLetgo](#) 03:21 10/29

Ok, sure, please use them, no worry! Hope a successful paper! :)

Figure 27 HiLetgo Red Laser Diodes and Phototransistors Permissions

Order ID 114-3368560-2536257:
1 of 5MM Flat-Head PHOTOTRANSISTOR Photo Transistors NPN Phototransisto 400-1100nm
SGT5516GK(20 Pieces) [ASIN: B07WWYH3WZ]

----- Begin message -----

Hello,

I'm an Engineering student at the University of Central Florida. I'm currently working on a paper for my senior design project. I'd like to request permission to use the photo of the following part:
5MM Flat-Head PHOTOTRANSISTOR Photo Transistors NPN Phototransisto 400-1100nm
SGT5516GK(20 Pieces)

https://nam02.safelinks.protection.outlook.com/?url=https%3A%2F%2Fwww.amazon.com%2Fgp%2Fproduct%2FB07WWYH3WZ%2Fref%3Dppx_od_dt_b_asin_title_s00%3Fie%3DUTF8%26psc%3D1&pddata=02%7C01%7Ckwikoff100%40knights.ucf.edu%7C8b76f235244a47d2356808d76611a665%7C5b16e18278b3412c919668342689eeb7%7C0%7C0%7C637090098300755487&pddata=2C4apvmbwhVifmCO9zLRctwUJ22mznUD7IR0iVnpFCk%3D&reserved=0

Thank you and have a great day,
Krystyn Wikoff

You have received a message from the Amazon Seller - Shine Gold Electronics Store

Order ID: 114-3368560-2536257

Count	Product Name and ASIN
1	 <p>5MM Flat-Head PHOTOTRANSISTOR Photo Transistors NPN Phototransisto 400-1100nm SGT5516GK(20 Pieces) ASIN: B07WWYH3WZ</p>
OK	

Figure 28 SGT5516GK Phototransistor Permissions

Hello Alexis Lamb,

Thank you so much for asking. You go right ahead and use whatever pictures you need from our website. Good luck on your project and have a great Thanksgiving.

Thank you,

Julie Randolph
Global Sales Representative
DIGI-KEY ELECTRONICS
[701 Brooks Ave S](#)
[Thief River Falls, MN 56701 USA](#)
orders@digkey.com
Domestic: 1 800 344 4539 x 12360
International: 1 218 681 7979 x 12360

Hello,

I'm an Engineering student at the University of Central Florida. I'm currently working on a paper for my senior design project. I'd like to request permission to use the photo of the following parts:

VLM-52-28 LPT

<https://www.digkey.com/product-detail/en/quarton-inc/VLM-520-28-LPT/VLM-520-28LPT-ND/9770707>

SD057-11-21-011

<https://www.digkey.com/product-detail/en/advanced-photonix/SD057-11-21-011/SD057-11-21-011-ND/1012484>

PDB-C142

<https://www.digkey.com/product-detail/en/advanced-photonix/PDB-C142/PDB-C142-ND/480581>

Thank you and have a great day,
Alexis Lamb

Figure 29 Digi-Key Photo Permissions

9.2 References

- [1] "Laser Harps," [Online]. Available: <http://www.kromalaser.com/laser-harp>. [Accessed 3 Nov 2019].
- [2] "Laser Harp," [Online]. Available: <https://www.jacobathompson.com/laser-harp>. [Accessed 13 Oct 2019].
- [3] "Arduino Laser Harp," [Online]. Available: <https://www.instructables.com/id/Arduino-Laser-Harp-1/>. [Accessed 17 Oct 2019].
- [4] "Frameless Laser Harp," [Online]. Available: <https://www.instructables.com/id/Frameless-Laser-Harp/>. [Accessed 21 Oct 2019].
- [5] "Build a Two-Octave Laser Harp," [Online]. Available: <https://makezine.com/projects/build-two-octave-laser-harp/>. [Accessed 19 Oct 2019].
- [6] "Musical Sounds," [Online]. Available: https://www.daviddarling.info/encyclopedia_of_music/M/musical_sounds.html. [Accessed 27 October 2019].
- [7] B. Davis, "Analog Violin Audio Synthesizer," California Polytechnic State University, San Luis Obispo, 2014.
- [8] "Red Lasers," [Online]. Available: https://www.rp-photonics.com/red_lasers.html. [Accessed 13 Oct 2019].
- [9] "Green Laser Levels vs. Red Laser Levels – What's the difference?," [Online]. Available: <https://www.craftedgarage.com/green-laser-levels-vs-red-laser-levels-whats-the-difference/>. [Accessed 19 Oct 2019].
- [10] 27 Oct 2019. [Online]. Available: <https://www.adafruit.com/product/1054>.
- [11] "Green Lasers," [Online]. Available: https://www.rp-photonics.com/green_lasers.html. [Accessed 13 Oct 2019].
- [12] "What's the Difference Between Green and Red Laser Line Levels?," [Online]. Available: <https://www.forconstructionpros.com/concrete/article/20996852/whats-the-difference-between-green-and-red-laser-line-levels>. [Accessed 14 Oct 2019].
- [13] [Online]. Available: <https://www.digikey.com/product-detail/en/quarton-inc/VLM-520-28-LPT/VLM-520-28LPT-ND/9770707>. [Accessed 3 Nov 2019].
- [14] "Lights88 532nm Green Laser Module Diode Stage Light moduler with Cable(50mw Green Dot Laser Module)," [Online]. Available: https://www.amazon.com/Lights88-532nm-Green-Module-moduler/dp/B076HMNN4K/ref=sr_1_4?keywords=green+laser+diode&qid=1573585682&sr=8-4. [Accessed 29 Oct 2019].

- [15] "RF Wireless World," 2012. [Online]. Available: <https://www.rfwireless-world.com/Terminology/Advantages-and-Disadvantages-of-Photoresistor.html>. [Accessed 7 Oct 2019].
- [16] "ResistorGuide," 2019. [Online]. Available: <http://www.resistorguide.com/photoresistor/>. [Accessed 6 Oct 2019].
- [17] "Difference Between Photodiode & Phototransistor," [Online]. Available: <https://circuitglobe.com/difference-between-photodiode-and-phototransistor.html>. [Accessed 27 Oct 2019].
- [18] "Light Sensors," [Online]. Available: https://www.electronicstutorials.ws/io/io_4.html. [Accessed 22 Oct 2019].
- [19] "Advanced Photonix SD057-11-21-011," [Online]. Available: <https://www.digikey.com/product-detail/en/advanced-photonix/SD057-11-21-011/SD057-11-21-011-ND/1012484>. [Accessed 2 Nov 2019].
- [20] "Advanced Photonix PDB-C142," [Online]. Available: <https://www.digikey.com/product-detail/en/advanced-photonix/PDB-C142/PDB-C142-ND/480581>. [Accessed 2 Nov 2019].
- [21] "Electronics Notes," [Online]. Available: https://www.electronics-notes.com/articles/electronic_components/transistor/what-is-a-phototransistor-tutorial.php. [Accessed 7 Oct 2019].
- [22] "HiLetgo 20pcs 5MM Photodiode Photosensitive Diode Light Sensitive Diode Round F5 Photodiode 3V," [Online]. Available: https://www.amazon.com/HiLetgo-Phototransistor-Photosensitive-Sensitive-Sensors/dp/B00M1PMHO4/ref=sr_1_1?keywords=phototransistor&qid=1573586850&sr=8-1. [Accessed 18 Oct 2019].
- [23] "5MM Flat-Head PHOTOTRANSISTOR," [Online]. Available: https://www.amazon.com/Flat-Head-PHOTOTRANSISTOR-Transistors-Phototransisto-400-1100nm/dp/B07WWYH3WZ/ref=sr_1_17?crid=3EAJSBQD6CLKW&keywords=phototransistor&qid=1572360454&s=industrial&srefix=photo%2Cindustrial%2C166&sr=1-17#detail-bullets. [Accessed 3 Nov 2019].
- [24] "OSRAM Opto Semiconductors SFH 3310," [Online]. Available: <https://www.mouser.com/ProductDetail/OSRAM-Opto-Semiconductors/SFH-3310?qs=sGAEpiMZZMs50KUSuyRkpuTdSuHeRW6pGNLxaaQkTro%3D>. [Accessed 4 Nov 2019].
- [25] "Complete Guide for Ultrasonic Sensor HC-SR04 with Arduino," 2019. [Online]. Available: <https://randomnerdtutorials.com/complete-guide-for-ultrasonic-sensor-hc-sr04/>. [Accessed 7 Oct 2019].
- [26] Dejan, "How Rotary Encoder Works and How To Use It with Arduino," [Online]. Available: <https://howtomechatronics.com/tutorials/arduino/rotary-encoder-works-use-arduino/>. [Accessed 30 October 2019].
- [27] "Tech Stuff - Frequency Ranges," 19 October 2019. [Online]. Available: <http://www.zytrax.com/tech/audio/audio.html>. [Accessed 27 October 2019].

- [28] "Acoustic Glossary: O," [Online]. [Accessed 21 November 2019].
- [29] "Build A Great Sounding Amplifier (With Bass Boost) From The LM386," [Online]. Available: <http://www.circuitbasics.com/build-a-great-sounding-audio-amplifier-with-bass-boost-from-the-lm386/>. [Accessed 11 11 2019].
- [30] B. Ray, "Bluetooth Vs. Bluetooth Low Energy: What's The Difference?," 1 November 2015. [Online]. Available: <https://www.link-labs.com/blog/bluetooth-vs-bluetooth-low-energy>. [Accessed 12 November 2019].
- [31] "BLUETOOTH LE CHIPSET GUIDE 2019 AND BEYOND," 25 June 2019. [Online]. Available: <https://www.argenox.com/library/bluetooth-low-energy/bluetooth-le-chipset-guide-2019/>. [Accessed 12 November 2019].
- [32] "Microcontrollertips," [Online]. Available: <https://www.microcontrollertips.com/key-factors-consider-choosing-microcontroller/>. [Accessed 13 11 2019].
- [33] "Selecting between a microcontroller and microprocessor," [Online]. Available: <https://circuitdigest.com/article/selecting-between-a-microcontroller-and-microprocessor>. [Accessed 13 11 2019].
- [34] [Online]. Available: <https://www.microchip.com/wwwproducts/en/ATmega328>. [Accessed 11 11 2019].
- [35] "What's the Better Battery for Your Portables—Li Ion or Li Poly?," [Online]. Available: <https://www.electronicdesign.com/power/what-s-better-battery-your-portables-li-ion-or-li-poly>. [Accessed 20 November 2019].
- [36] "Nickel Cadmium Batteries," [Online]. Available: <https://www.mpoweruk.com/nicad.htm>. [Accessed 19 Nov 2019].
- [37] "Lead Acid Batteries," [Online]. Available: <https://www.mpoweruk.com/leadacid.htm>. [Accessed 19 Nov 2019].
- [38] "Alkaline Batteries," [Online]. Available: <https://www.mpoweruk.com/alkaline.htm>. [Accessed 20 Nov 2019].
- [39] "Li-Ion and LiPoly," [Online]. Available: <https://learn.adafruit.com/all-about-batteries/liion-lithium-ion-and-li-poly-lithium-polymer>. [Accessed 14 November 2019].
- [40] V. Dyvliash, "Java vs Kotlin: a Veteran against the Upstart Challenger," 14 June 2018. [Online]. Available: <https://belitsoft.com/apps-development-services/java-vs-kotlin>. [Accessed 7 Oct 2019].
- [41] "Welcome to ISO/IEC JTC 1/SC 29/WG 11 - MPEG," [Online]. Available: <https://mpeg.chiariglione.org/>. [Accessed 22 November 2019].
- [42] "Noise-Induced Hearing Loss," March 2014. [Online]. Available: <https://www.nidcd.nih.gov/health/noise-induced-hearing-loss>. [Accessed 14 November 2019].
- [43] "Difference between photoresistor and phototransistor | photoresistor vs phototransistor," [Online]. Available: <https://www.rfwireless->

- world.com/Terminology/Photoresistor-vs-Phototransistor.html. [Accessed 7 Oct 2019].
- [44] "Direct Green Laser Diodes," [Online]. Available: <https://www.digikey.com/en/pdf/o/osram-opto-semiconductors/osram-direct-green-laser-diodes>. [Accessed 11 Oct 2019].
- [45] [Online]. Available: <https://www.raspberrypi-spy.co.uk/2015/05/using-an-i2c-enabled-lcd-screen-with-the-raspberry-pi/>. [Accessed 22 10 2019].
- [46] "Learn Parallax," [Online]. Available: <http://learn.parallax.com/tutorials/robot/shield-bot/robotics-board-education-shield-arduino/chapter-6-light-sensitive-15>. [Accessed 23 Oct 2019].
- [47] "Potentiometers," [Online]. Available: <https://www.electronics-tutorials.ws/resistor/potentiometer.html>. [Accessed 30 October 2019].
- [48] D. L. Wei, Interviewee, *Senior Design I*. [Interview]. October 2019.
- [49] S. Richie, Interviewee, *Senior Design I*. [Interview]. October 2019.
- [50] Omnexus, "Density of Plastics: Technical Properties," Omnexus, [Online]. Available: <https://omnexus.specialchem.com/polymer-properties/properties/density>. [Accessed October 2019].
- [51] D. Budds, "This Invisible Joint Is Making Ikea's Furniture Stronger And Easier To Build," *Fast Company*, 18 January 2017. [Online]. Available: <https://www.fastcompany.com/3067215/how-ikea-designs-a-new-dowel>. [Accessed October 2019].
- [52] R. Noe, "How Ikea's New Joinery is Advancing Their Design," *Core77*, 3 January 2017. [Online]. Available: <https://www.core77.com/posts/59321/How-Ikeas-New-Joinery-is-Advancing-Their-Design>. [Accessed October 2019].
- [53] P. Lynch, "These Mesmerizing GIFs Illustrate the Art of Traditional Japanese Wood Joinery," *ArchDaily*, 7 October 2016. [Online]. Available: <https://www.archdaily.com/796918/these-mesmerizing-gifs-illustrate-the-art-of-traditional-japanese-wood-joinery>. [Accessed October 2019].
- [54] T. Rogers, "Everything You Need To Know About Overmolding Prototypes," *Creative Mechanisms Blog*, 26 August 2015. [Online]. Available: <https://www.creativemechanisms.com/blog/overmolding-prototype-design-development>. [Accessed October 2019].
- [55] N. Trivellin, "Laser-Based Lighting: Experimental Analysis and Perspectives," *DEI—Department of Information Engineering—University of Padova, Via Gradenigo 6B, 35131 Padova, Italy*, vol. 10, no. 10, pp. 9-17, 2017.
- [56] PlastikCity, "Plastic Material Melt And Mould Temperatures," PlastikCity, [Online]. Available: <https://www.plastikcity.co.uk/useful-stuff/material-melt-mould-temperatures>. [Accessed October 2019].
- [57] Sargent Manufacturing Company, "Basic Technical Fundamentals of Builders Hardware Mortise, Bored and Auxiliary Locks," 2016. [Online].

- Available: <https://content.assaabloyusa.com/doc/AADSS1012196&.pdf>. [Accessed October 2019].
- [58] T. Youngblood, "Reading and Writing Files from an SD Card with an Arduino," All About Circuits, 2015. [Online]. Available: <https://www.allaboutcircuits.com/projects/reading-and-writing-files-from-an-sd-card-with-an-arduino/>. [Accessed October 2019].
- [59] S. Purohit, "Make a simple Arduino audio player that plays .wav files from an SD card in as little as 10 minutes," Maker Pro, 27 March 2017. [Online]. Available: <https://maker.pro/arduino/projects/arduino-audio-player>. [Accessed October 2019].
- [60] TMRh20, "Arduino library for asynchronous playback of PCM/WAV files direct from SD card," 2019. [Online]. Available: <https://github.com/TMRh20/TMRpcm>. [Accessed October 2019].
- [61] The Plug, "Portable Hard Drives vs. Flash Drives vs. SSDs vs. SD Cards," HelloTech, 17 April 2017. [Online]. Available: <https://www.hellotech.com/blog/portable-hard-drives-flash-ssd-sd>. [Accessed October 2019].
- [62] "ANSI Z136 Standards," [Online]. Available: <https://www.lia.org/resources/laser-safety-information/laser-safety-standards/ansi-z136-standards>. [Accessed 13 November 2019].
- [63] J. Martin, Programming real-time computer systems, Prentice-Hall, 1965.
- [64] "Resource Interchange File Format," Wikipedia, [Online]. Available: https://en.wikipedia.org/wiki/Resource_Interchange_File_Format. [Accessed November 2019].