Senior Design 1

Battle of the Bikes



University of Central Florida
Department of Electrical Engineering and Computer Science
Dr. Lei Wei

Group 20
Final Report

Adam Brower (Electrical Engineering)
Allison Kovarik (Electrical Engineering)
Nicolas Leocadio (Electrical Engineering)
Bo Williams (Computer Engineering)

Table of Contents

1. Executive Summary	1
2. Project Description	3
2.1 Market Analysis	3
2.2 House of Quality Analysis	4
2.3 Calorie Calculations	4
3. Research and Part Selection	6
3.1 Bicycles	6
3.1.1 Normal Bicycle Resistance	7
3.1.2 Resistance for a Stationary Bicycle	8
3.1.3 Bicycle Selection	9
3.2 Resistance Mechanism	9
3.2.1 DC Motor	9
3.2.2 Servo Motor	10
3.2.3 Stepper Motor	11
3.2.3.1 H-Bridge	12
3.2.4 Motor Comparison and Selection	13
3.2.5 Servo Comparison and Selection	14
3.2.6 Changing Resistance	15
3.3 Speed Sensing	16
3.3.1 Hall Effect Sensor	17
3.3.2 Hall Effect Sensor Requirements	18
3.3.3 Hall Effect Sensor Selection	19
3.4 Generator	20
3.4.1 AC Generation	20
3.4.2 DC Generation	21
3.4.3 Generator Selection	21
3.5 Battery	23
3.5.1 Lithium-Ion Battery	24
3.5.2 Sealed Acid Battery	26
3.5.3 Battery Selection	27
3.6 Microcontroller	28
3.6.1 Types of Microcontrollers	29

3.6.1.1 Atmel AVR	30
3.6.1.2 Arduino	31
3.6.1.3 Texas Instruments MSP	32
3.6.1.4 Microchip Technology PIC	33
3.6.1.5 Raspberry PI	34
3.6.2 Choice of Microcontroller	35
3.7 Display	36
3.7.1 Liquid Crystal Display	36
3.7.1.1 Hitachi HD44780	36
3.7.1.2 The Arduino and HD44780	36
3.7.2 Touchscreen	37
3.7.2.1 Resistive	37
3.7.2.2 Capacitive	38
3.7.2.3 Measuring Change in a Touchscreen	38
3.7.3 Touchscreen vs LCD	39
3.7.4 Comparison of LCDs and Choice	40
4. Design Constraints and Standards	40
4.1 Project Constraints	40
4.2 Requirements and Specifications	41
4.3 Standards	41
4.3.1 Wireless Communication	41
4.3.1.1 IEEE 802.11	41
4.3.1.1.1 The Media Access Control Layer	42
4.3.1.1.2 The Physical Layer	43
4.3.1.2 IEEE 802.15	44
4.3.1.2.1 Transport Layer	44
4.3.1.2.1.1 Radio Layer	44
4.3.1.2.1.2 Baseband and Link Layers	45
4.3.1.2.2 Middleware Layer	45
4.3.1.2.3 Bluetooth Security	46
4.3.2 C Language Coding Standards	46
4.3.2.1 Names	46
4.3.2.2 Formatting	47

4.3.2.3 Documentation	48
4.3.2.4 Complexity Management	49
4.3.2.5 Miscellaneous	49
5. Design	49
5.1 Circuit Protection	49
5.2 Regulator Components	49
5.2.1 Transistor	50
5.2.2 Field-effect Transistor	51
5.2.3 Metal-Oxide Semiconductor Field-effect Transistor	51
5.2.4 Bipolar Junction Transistor	52
5.2.5 Diode	53
5.3 DC Regulator Types	54
5.3.1 Passive Regulators	54
5.3.1.1 Voltage Divider Circuit	54
5.3.2 Active Regulators	55
5.3.2.1 Linear Regulators	55
5.3.2.2 Shunt Regulator	55
5.3.2.3 Transistor Regulator	56
5.3.2.4 Operational Amplifier Regulator	57
5.3.2.5 Low Dropout Regulator	58
5.4.3 Switching Regulators	59
5.4.3.1 Buck Regulator	60
5.4.3.2 Boost Regulator	61
5.4.3.3 Buck-Boost Regulator	62
5.4.3.4 Flyback Regulator	63
5.3.4 Push-Pull Converter	64
5.4 Input Power Conversion	65
5.5 Pulse Width Modulator	66
5.5.1 Bubba Oscillator	66
5.5.2 AC/DC Converter	67
5.6 Battery Management System	70
5.6.1 Battery Charging	71
5.6.1.1 Battery Charging Circuit	72

5.6.1.2 Charging from Outlets	74
5.6.1.3 Maximum Battery Current	74
5.7 Output Power Conversion	75
5.7.1 Power Requirements	75
5.7.2 DC-AC Inverter	75
5.7.3 DC-DC	76
5.8 Low Dropout Regulator Circuits	76
5.9 Wireless Communication	80
5.9.1 Zigbee Standard	81
5.9.1.1 XBee and Arduino	81
5.10 Bluetooth Low Energy	82
5.10.1 Generic Access Profile	83
5.10.2 Generic Attribute Profile	83
5.10.3 GATT Transactions	84
5.11 Wi-Fi	86
5.12 Comparison of Wireless Communications	86
5.13 Transceiver Design	87
5.13.1 Radio Frequency Fundamentals	87
5.13.2 RF Printed Circuit Board	89
5.13.3 Receiver (RX) Path	91
5.13.4 Transmitter (TX) Path	92
5.13.5 Transceiver Elements	93
5.13.5.1 Analog to Digital Converter	93
5.13.5.2 Antenna	94
5.13.5.3 Band Pass Filters	98
5.13.5.4 Digital to Analog Converter	99
5.13.5.5 Downconverter Mixer	100
5.13.5.6 Low Noise Amplifier	101
5.13.5.7 Phase-Locked Loop	102
5.13.5.8 Power Amplifier	103
5.13.5.9 Quadrature Hybrid	103
5.13.5.10 RF Balun	104
5.13.5.11 RF Switch	105

5.13.5.12 Up Converter Mixer	106
5.13.5.13 Wilkinson Power Divider/ Combiner	107
5.14 Software	108
5.14.1 Phone Application	110
5.15 Game Design	111
6. Integration	112
6.1 Board Manufacturing	112
6.2 Prototype Construction	113
6.3 Test Plan	114
6.3.1 BLE Module Testing	115
6.3.2 BLE Network Testing	115
6.3.3 DC Generator Testing	116
6.3.4 Servos Motor Testing	117
7. Administration	118
7.1 Project Schedule & Milestones	118
7.2 Project Budget	119
7.3 Project Organization	120
8. Conclusion	122
9. Appendices	124
9.1 References	124
9.2 Copyright Permissions	126

1. Executive Summary

Many gyms are now offering group exercise classes to entice members to become more motivated to get and stay in shape. Examples of these classes are yoga, Pilates, Zumba, kickboxing and cycling. Classes are typically available twice a day at differing times throughout the week, making it difficult to have a set workout schedule. The classes are mostly based on aerobic exercise, meaning they raise the participant's heart rate for an extended period of time. Interestingly, most attendees are millennials, and females outnumber males 5 to 1. In addition, a Nielson study found that 85 percent of active members visit the gym at least twice a week solely to participate in these group classes (club industry), leaving a disproportionate number of middle-aged males in the dust. With the typical member being 40 years old, what can fitness clubs do to entice their male constituents to participate in necessary cardiovascular activities? The answer is simple: Make cardio more enjoyable by turning it into a game rather than a group activity.

Group exercise activities are becoming increasingly more prominent in today's world as they are a great way for friends and strangers alike to spend time with each other while also bettering both their health and physiques. By analyzing these trends and determining their implications, we decided to create a stationary bicycle game in which two players will face off in a race while generating the energy to power the systems that they use.

The Battle of the Bikes is a novel approach to motivate those who feel out of place in group exercise classes or simply cannot fit one into their hectic schedule. Our goals for this project include creating an enjoyable and competitive way to focus the users' attention while performing exercises that may otherwise be undesirable due to their normally repetitive nature, as well as generating power from the effort that is put in by the users in order to have a fully self-sufficient system that is untethered from the outside world.

The setup includes two stationary bicycles that are interconnected to race against each other, which is ideal for the 44 percent of gym-goers who work out with a partner. The bikes will have a user interface to indicate speed and distance, the gear the bike is in, as well as the status of the other person biking with you.

To focus the users' attention, we will create a competitive racing game in which the players will earn power-ups. At certain milestones, such as a sustained speed for a period of time, the rider will then have the opportunity to sabotage his or her co-rider. There will be an indicator that you have received an object and the ability to accept or deny that object. If accepted, the rider's bicycle sends a signal to its counterpart, causing the opponent's bike to shift to the

lowest gear. This effectively has the opponent spinning his or her wheels, covering less distance. In addition, if one player is behind by a certain distance, the before mentioned ability will be made available. This causes both partners to push each other to perform better while keeping both engaged. Research has found working out with a partner perceived as better can cause workout length and intensity to skyrocket by 200 percent.

This will have a real-life impact that the players will be immediately able to see, making the game enjoyable and rewarding, and motivating players to continue playing. This will also have a desired effect of inciting competition between players and will also allow for meaningful interactions and maybe even the formation of new friendships between players. The game will be centered around the distance that the players choose to race for, which will in turn determine how frequently the players get power-ups and how fast paced the game will be.

To generate a self-sufficient power system that does not require external inputs, our bicycles will be equipped with motors that will spin from the pedaling motion of the players, which will in turn convert energy that is normally wasted into a useful DC signal that will both power our entire system and any accessories that may be plugged in to it. The power outputs may also be used to power other items such as lamps or monitors but will quickly drain the system due to the low storage capacity of our battery system.

The signal that is generated from both bicycles will be combined and converted in order to be stored in the battery. Each bicycle will have a system for monitoring the power that is generated by it so that we can use this data to give the players power-ups and general information about their workout. This converter will ensure that the power supplied to the battery is always in the right voltage range so that the battery does not become damaged. It will also ensure that the power delivered is always constant so that there are no surges in the system that could damage other components.

The power and battery at this point will also be monitored by a battery monitoring system. This system will allow us to watch many different aspects of the battery, including temperature and voltage, and will more importantly handle any excess power that is delivered to the battery, allowing for less energy waste than if excess power was simply disregarded. The battery management system will also handle the output of power to the internal components of each bicycle, ensuring that all components receive the proper power for optimal function.

The following image displays the main control scheme of how the two bicycles will communicate with each other and process the game. One of the bicycles will contain the main unit, which will provide all of the input processing and create the outcome of the game for the players. This unit will also house the

battery and power conversion systems, which will allow for easy control over all of the systems that we will have.

The overall system will be controlled by both microcontrollers and PCBs. We will limit the amount of processing done by the microcontroller to only what is necessary. This will include reading measurements from the battery monitoring system as well as speed sensors that will be placed on either bicycle. The microcontrollers will also be used to control the amount of tension or resistance that is applied to the foot pedals of the users since that is an action that is directly related to the game that will be played.

2. Project Description

2.1 Market Analysis

Currently, there are two different options for cycling in a fitness club. The first is group exercise classes. As mentioned before, these classes occur at certain times depending on the availability of the instructor and are a specified length. The second option is to go to the cardio section of the gym and find a stationary bike, for which you can change settings for different intensity rides.

At home, there are three stationary bicycle options. The first allows the gym group exercise experience brought to you. The Peloton Indoor Exercise Bike includes a 22 inch HD display with which the user can access unlimited cycle classes for monthly membership of \$39. The cost of the equipment itself is \$2,245 (Peloton), making it inaccessible to many. The second is a stationary bike much like that in the cardio section of the gym which can be situated in whatever manner the owner would like, be it facing a window, television, etc. The third option allows the user to connect to his or her television to play a racing game.

While options for cycling at the gym and at home each have their own benefits and drawbacks, none motivates the users with healthy competition. This sets the Battle of the Bikes apart from its cohorts in the market. The Battle of the Bikes allows its riders to maximize the health benefits of aerobic exercise that the average 40-year-old gym-goer needs, such as improving heart, lung and mental health, all while still having fun with his or her partner.

2.2 House of Quality Analysis

The house of quality diagram is shown below in Figure 1. The items that we have focused on in this diagram are the functionality and connectivity of the bicycle as well as the power generated and the speed.

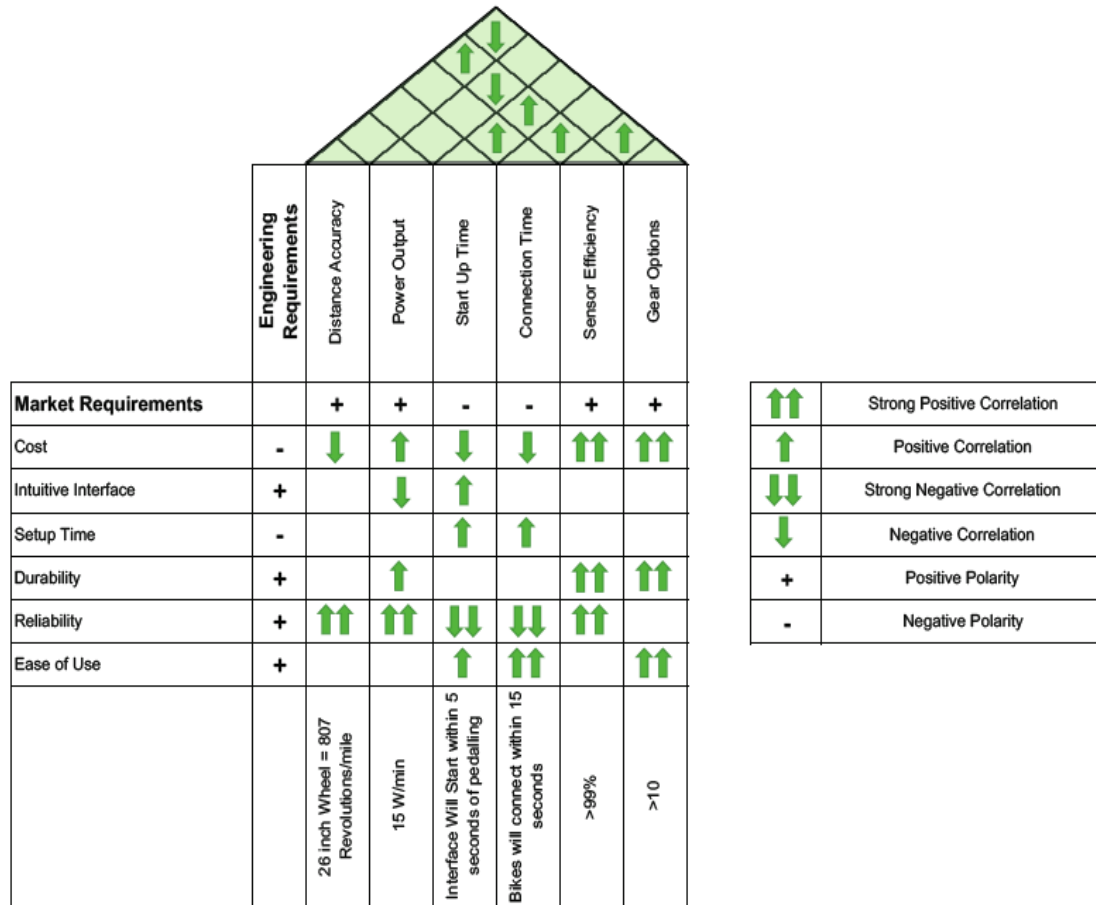

Figure 1. House of Quality Diagram

2.3 Calorie Calculations

The Battle of the Bikes will be powered by the users after the initialization of the system. When doing calculations for powering the system, we will use the Calories burned by the users during use of the system. A Calorie is a measure of stored chemical energy from the food that we ingest. That energy is transformed into heat and mechanical energy for the body to use. The typical human body has a Gross Metabolic Efficiency of about 20% to 25%. That means when the body burns 1 Calorie, instead of producing 4.184 kJ of work, it will only produce 1.045 kJ of work. So, most cyclists approximate 1 Calorie as 1 kJ of work. So, we know that a Calorie is 1000 Joules. Speaking in terms of power, we know

that a Joule is defined as Watts*seconds. By manipulating that statement, we can get the following equation:

$$Power(Watts) = \frac{Joules}{Seconds}$$

Using the approximation that a Calorie is 1000 Joules:

$$Power(Watts) = \frac{Calories}{1000 \times Seconds}$$

When calculating the calories, a cyclist burns, we need to take into consideration the user's weight and the metabolic equivalent for a task (METs) of the activity. METs are defined as a unit that estimates the amount of energy used by the body during physical activity, as compared to resting metabolism. The calculation of Caloric burn and power output are shown below:

$$Calories Burned = 0.0175 \times MET \times Weight(kg) \times Minutes$$

By manipulating the equations above, we get:

$$Power(Watts) = \frac{Calories}{3.6 \times Hours}$$

Cycling METs can be divided up in multiple ways: average speed of the user and average Wattage output. MET levels under 3 are considered light-intensity activities. MET levels between 3 and 6 are considered moderate-intensity activities. MET levels over 6 are considered vigorous-intensity activities. The division of the METs for cycling are shown below in Tables 1 and 2:

MET	Description
4	Less than 10 mph on average
6	10 to 11.9 mph on average
8	12 - 13.9 mph on average
10	14 - 15.9 mph on average
12	16 - 19 mph on average
16	Greater than 20 mph on average

Table 1. METs values based off average speed

MET	Description
3	Stationary bike, 50 W generated
5.5	Stationary bike, 100 W generated
7	Stationary bike, 150 W generated
10.5	Stationary bike, 200 W generated
12.5	Stationary bike, 250 W generated

Table 2. METs values based off power generated

When being used in the calculations, the program will decide which MET is best to use based off a set percentage of the values that are calculated. If the values are too far away from the Watts generated, the program will decide to use the MET value from the speed table instead.

3. Research and Part Selection

3.1 Bicycles

The actual layout of our project will consist of two bicycles positioned next to each other, with each housing its own components and physically connecting only to send and receive power to and from the battery system. Each bicycle will then contain a microcontroller and display, a PCB for power management and wireless communications, a generator setup to generate electricity from the effort of the users, and a mechanism that will change the tension setting of the bicycle for game functionality.

For the actual bicycle, we have the options of using normal bicycles and converting them into stationary bicycles, or we could buy stationary bicycles that will already have some wanted features. When choosing a bicycle, we must be kept in mind its pricing and availability since we will be needing two of them, and if the chosen bicycle already has a tension or gearing mechanism which we could hook into for our game.

Regular bicycles have the perk of being relatively cheap and easy to find and would also allow us to easily include steering in our video game. There would also be easy access to the rear wheel, which we will need to interact with fairly frequently. However, setting the game up with a normal bicycle would involve creating a stand and holding mount on which the bicycle can go on so that it will

not move while being used, and so that we can convert its movement into electricity. A new system in which we can exert different levels of tension onto the pedals would also be required for our game functionality, which would be doable but would require a lot of extra time and effort for a purely mechanical system.

3.1.1 Normal Bicycle Resistance

The Battle of the Bikes system will require an automated mechanism to change the tension of the bicycles while the users are pedaling. This is because we want the game to feel like a competition between two players, but a fun one. When considering how this can be done, we have several options depending on what kind of bicycles we use.

With a normal bicycle, we will preferably purchase a bicycle which already includes some gearing mechanism so that we can simply hook into the system rather than creating one from scratch. Mountain bicycles use what are called derailleurs, where a chain drives one of multiple sprockets and can be switched between the various sprockets. Sprockets are very similar to gears except that they may never be meshed together and are used to transfer rotary motion between two objects. The bicycle becomes hardest to pedal when the chain is in the largest sprocket in the front and smallest in the back and becomes easiest to pedal in the opposite configuration.

There are two types of derailleurs: front and rear. The rear derailleur keeps the chain taut and switches between sprockets, while the front derailleur switches between three front sprockets. In a front derailleur, since the top of the chain is moved and is the part that is under tension while pedaling, cycling must cease while the sprockets are being changed. This is not a problem for rear derailleurs, so we would go with a rear derailleur for this project if a normal or mountain bicycle is chosen. The following image illustrates the drivetrain of a bicycle and illustrates the front and rear derailleur system. The rear is on the left and the front is on the right of the image. There are several different sprockets that the rear derailleur can choose between, and only a few in the front.

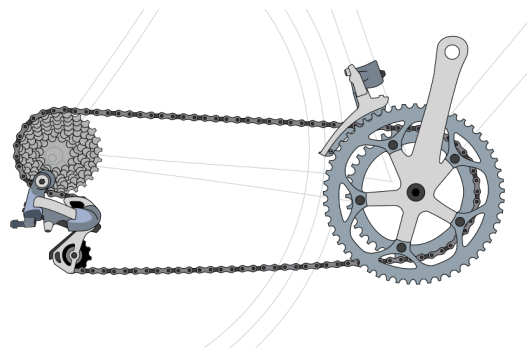

Figure 2. Derailleur System

3.1.2 Resistance for a Stationary Bicycle

For a stationary bicycle, a tension mechanism will already be included. The included mechanism is generally internal in the bicycle and is toggled through a knob located near the handles. Below is an example of a stationary bicycle to demonstrate how this project could be set up with one. The knob at the front of the bicycle, under the arm rests, is how the resistance is controlled for the pedaling of the bicycle. This would be easy to set up with depending on what kind of motors and chains we want to use. The rear of the bicycle is also easily accessible, making it very easy for us to connect our generator setup to it.



Figure 3. Example of a Stationary Bicycle

We will then have several options to create a system that applies rotary motion to the knob or the actual mechanism of the bicycle in order to change the tension of the pedals when a power-up is used by the opposing player. In this system, the rotary motion will need to be as fast as possible in order to minimize any slipping that could occur from switching gears or changing tension. We are then faced with choosing between a DC motor, servo motor, or stepper motor.

3.1.3 Bicycle Selection

	Normal Bicycle	Stationary Bicycle
Pros	<ul style="list-style-type: none">• Cheaper• Readily available• Easy to attach to motor	<ul style="list-style-type: none">• Already stationary• Steady• Includes resistance mechanism
Cons	<ul style="list-style-type: none">• Resistance tricky to tap into• Requires a mount to be made	<ul style="list-style-type: none">• More expensive• Heavy

Table 3. Bicycle Comparison

After carefully considering our options for bicycles, we have decided to utilize already made stationary bicycles for several reasons. The first of these reasons is that it will be much easier to simply turn a knob to change the resistance of the bicycles than it will be to attempt to tap into a derailleur system of an ordinary bicycle.

3.2 Resistance Mechanism

3.2.1 DC Motor

A DC motor would provide continuous rotation and high RPM when powered. DC motors work by producing a magnetic field to generate movement via electromagnetism. This is done by either wrapping a wire coil around a piece of iron and running a current through the coil, or by having an armature and running a current through that. Then, magnets are placed on either side of the piece of the iron piece or armature which in turn create a torque due to the force exerted onto the iron piece or armature by the magnetic fields of the permanent magnets.

A high RPM is not necessarily a wanted trait for our tension system since we will want to mostly use two predetermined settings for the tension knob. Continuous rotation is also not a desired effect as we want precise control over the knob's angular position. Therefore, we will move on to servo motors and stepper motors.

3.2.2 Servo Motor

A servo motor includes a built-in DC motor with three other features: a gearing set, a potentiometer, and a control circuit. The image below illustrates the general contents of a servo motor:

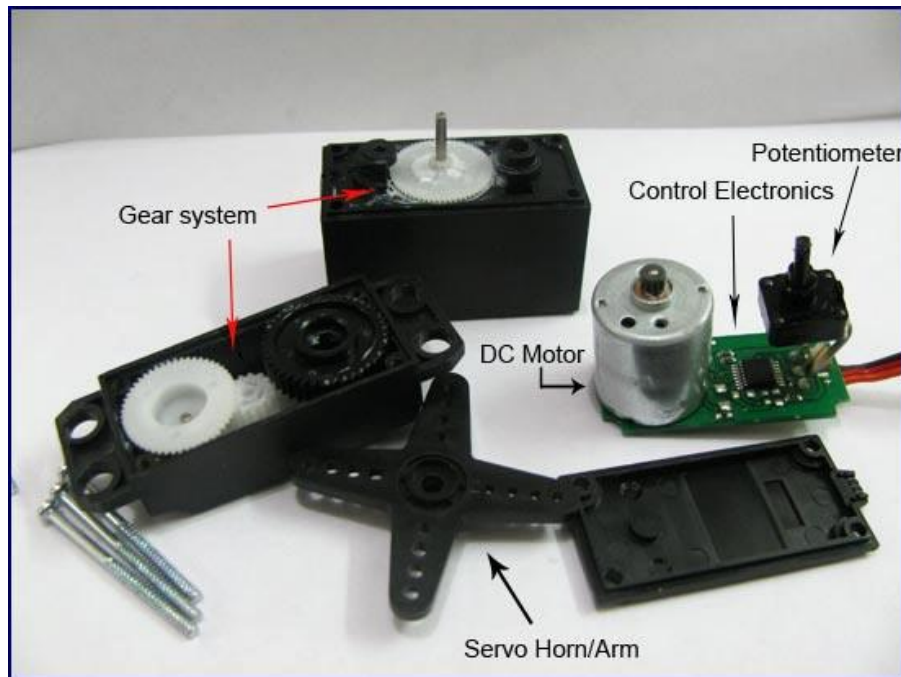

Figure 4. Inner Mechanism of a Servo

The DC motor is attached to the gearing set and a control wheel, and when they rotate they change the resistance of the potentiometer. This change in resistance allows for the control circuit to determine how the motor is moving and therefore regulate how it moves. The motor's speed changes based on how far from the desired position the shaft is, spinning slower as it reaches the desired position. Power is only applied to the motor while it is moving and is cut when the shaft achieves the desired position.

These features allow for servo motors to have much finer control over their position than DC motors. However, servo motors are limited to about 180° of angular motion, which would limit the amount of tension that we are able to apply to the bicycle since the knob would need to be fully turned in order to have a full range of useful tension at the pedals. This is something that we could work with, as we can calibrate the servo motor to be within a certain wanted range of tension, but it would not be an ideal solution as we would have to limit either or both of the maximum and minimum tensions that can be applied to the bicycle pedals.

The servo is controlled using pulse width modulation, receiving a pulse every 20 milliseconds. The servo is kept centered with a neutral pulse of about 1.5ms and can be turned clockwise by increasing the pulse length, or counter-clockwise with a shorter pulse. Servo motors are also resistant from external forces, since the pulse width that it receives essentially tells the servo where to be located, and the maximum amount of external force it can withstand is the torque rating of the servo.

3.2.3 Stepper Motor

Stepper motors are similar to servo motors but have a completely different mechanism for rotation, and this mechanism allows for the servo motors to have even finer control over their angular position. They also can hold their current position without the need for any power due to how their internal mechanism works. The way that stepper motors function is through an external control circuit which controls two electromagnets inside of the motor. The two electromagnets are switched on and off in an alternating pattern, which causes an internal gear to turn one tooth at a time. This allows for very fine control over the motor's position. Typically, stepper motors will have between 4 and 400 steps, and step counts of 24, 48, and 200 are commonly found. The number of steps in the motor determines the amount of rotation in degrees that the motor will have per step, so dividing 360 by the number of steps will yield the amount of degrees spun per step. Stepping is a desirable trait for our tension system as we will be wanting to turn in very specific increments in order to allow for the tension in the bicycle to be properly changed. Another way to achieve better positioning is through using a gear train, which allows for a multiplication between the gear ratio and the steps of the stepper motor. However, this would not be useful for our project as we will be looking to have as few steps as possible in order to change between positions of the tension knob as fast as possible.

The shaft style of the stepper motor must also be considered since this is how the motor will interact with the rest of the tension system. The first style is a round or "D" shaft, where a simple shaft extends from the center of the motor. Round shafts are cylinders and "D" shafts have a flattened side to help fit things onto it, and they are available in many different diameters. A gear or pulley system is then fitted onto the shaft, which would then turn the knob that controls the tension of the pedals. Next is a geared shaft, which have gear teeth embedded into them. This allows for the shaft to interact with gear trains or chains, and also prevents slippage as the teeth lock the system in place. Last are lead-screw shafts which are typically used for linear actuators. A system could be developed around this style of shaft, but ultimately a rotary system will be most efficient.

Stepper motors have pins in which the control circuit is connected to, which allows for the switching on and off of the internal electromagnets. The control circuit can be either a logic circuit or a microcontroller, which would allow us to tie the control of the tension system directly to the microcontroller, making it directly changed by the game mechanics. There are two types of stepper motors: bipolar and unipolar. In unipolar stepper motors, only one of the electromagnets is activated at a time in order to achieve rotation. Each electromagnet is activated by either a negative or positive lead, so changing the polarity of the input will activate one electromagnet and turn off the other. This leads to a lower overall torque provided by the motor. In bipolar motors, both electromagnets are connected via an H-bridge which allows for current to be reversed through the coils of the electromagnet. This allows for all of the electromagnets in the motor to be activated for each step, providing higher output torque from the motor. The following image illustrates the components of a stepper motor.

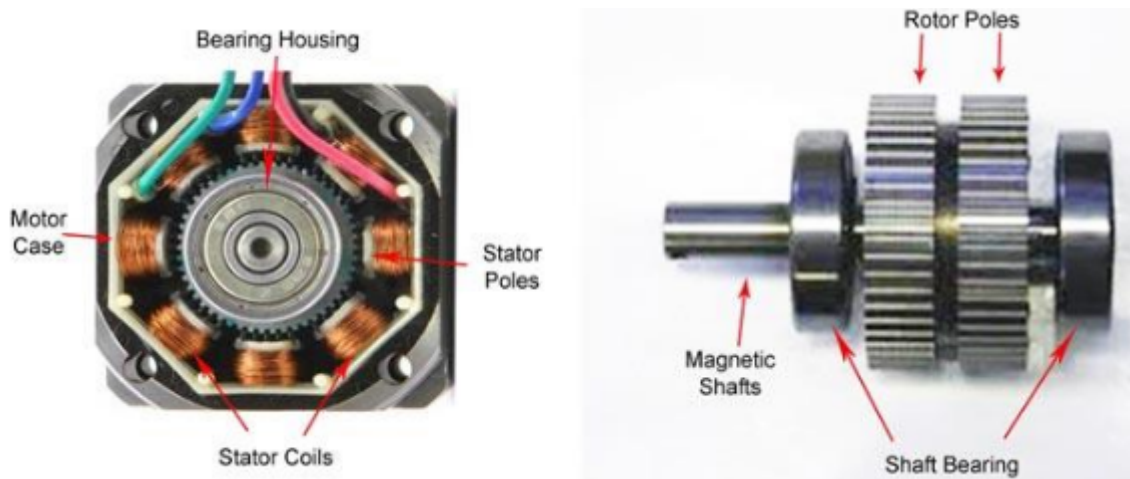

Figure 5. Inner Mechanism of a Stepper Motor

3.2.3.1 H-Bridge

An H-Bridge is a circuit with four switching elements and a load in the center, illustrated below. For a stepper motor, the function of the H-bridge is simply to switch the direction of the current being provided to the motor, therefore we have two useful modes: Q1 and Q4 being turned on, allowing a current to flow through the from the source to ground; and when Q2 and Q3 are turned on, creating a similar scenario as previously but now with these switches.

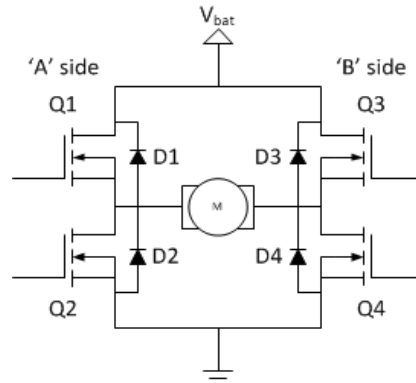

Figure 6. H-Bridge Circuit Diagram

The following is the truth table behind the H-bridge circuit.

Q1	Q2	Q3	Q4	Function
0	0	0	0	Coast
1	0	0	1	Forward
0	1	1	0	Reverse
1	1	0	0	Brake

Table 4. H-Bridge Truth Table

3.2.4 Motor Comparison and Selection

When choosing the type of motor to use for changing the tension of the bike, there were many factors that we had to take into consideration. These factors are shown in Table 5. The main factors that we cared about were the torque and power required to run the motors.

	DC Motor	Servo Motor	Stepper Motor
RPM	High	Low	Low
Torque	Wide Range	Wide Range	Wide Range
Precision	Low	Medium	High
Power Required	High, for movement	Low, constant	Low, for movement
Complexity	Simple	Multiple Components	Multiple Components

Table 5. Motor Comparisons

After carefully analyzing all of our options for motors, we have decided to use a servo motor to change the resistance of our bicycles. When making this decision, we carefully considered the pros and cons of each type of motor. Since this application requires a high torque and somewhat precise but quick motion, a servo motor seems like the logical choice. The motor will be easily controlled by PWM from either the microcontroller or an overall control circuit, and will allow us to quickly interact with the resistance system from the game.

3.2.5 Servo Comparison and Selection

When deciding between the servo motors, we had a variety of specifications that we had to consider. The main factors being the torque generated by the motor and the power used to run the motor. The torque is important because we need a motor strong enough to hold the tension down as the resistance is at its peak. The power needed to run the motor is also very important because we do not want the motor drawing a lot of power from the battery.

	LD-27MG	DS3218MG	MG996R
Item	Full Metal Gear Standard Digital Servo	Digital Servo High Torque Full Metal Gear	Metal Gears Digital RC Servo Motor
Manufacturer	LewanSoul	ANNIMOS	Qunqi
Torque	20kg*cm	21.5kg*gm	13kg*cm
Dimensions	40*20*40.5mm	40*20*40.5mm	40*19*43mm
Speed	0.16sec/60°	0.14sec/60°	0.14sec/60°
Operating Voltage	6 - 7.4V	4.8-6.8V	4.8-7.2V
Min Working Current	1A	-	-
No-load Current	100mA	-	-
Price	\$17.49	\$17.99	\$10.89

Table 6. Servo Comparisons

From Table 6 comparisons, we have decided to use the LD-27MG servo motor. Although it is not the highest torque nor the fastest servo on the list, it will serve our purposes of turning a chain to change the resistance of the bicycles just fine. This servo was also one of the few that we could find with current ratings on it, making it optimal as we are able to calculate the power drain due to the servo and account for it in our overall system. The speed and torque ratings are also important on this specific servo motor because they are a middle ground of both when compared to the other two servos around it. This gives us a lower overall power consumption due to the servo being less power hungry for a higher torque. These factors are all very important since we are trying to conserve as much power as possible.

3.2.6 Changing Resistance

The servos will be used to drive the resistance mechanism of both bicycles. In order to do this, we will connect a servo to each bicycle, and connect that servo to the resistance mechanism of the bicycles with a chain. This will allow us to take advantage of the positional control of the servo as well as the high torque of the servo we selected since it will be directly applied to the chain and then the bicycle instead of the torque being lost to distance.

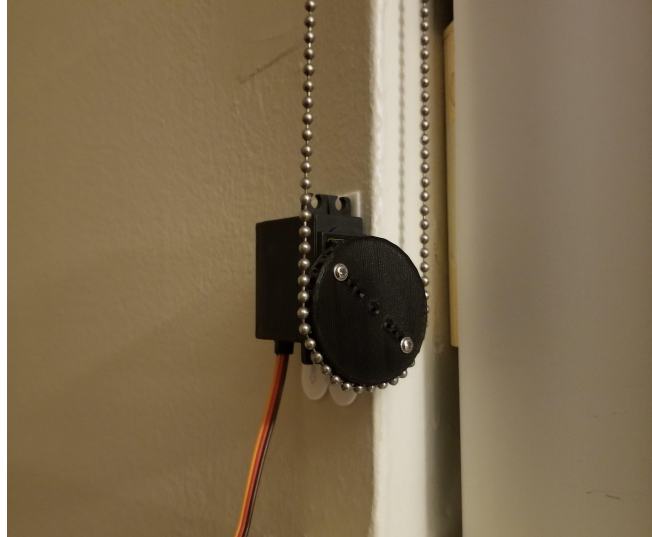

Figure 7. Example of Servo Function

To control the servo, pulse width modulation must be used. This is done by sending signals through the control wire of the servo, which has the parameters of minimum and maximum pulses, as well as a repetition rate. A servo in a neutral state will always be centered since there is the same potential for rotation clockwise and counter-clockwise. Then, the angle of the servo is controlled by sending different length pulses to the control wire, which is called pulse width modulation. The servo's period is 20 milliseconds, and the control pulse is between 1 and 2 milliseconds.

3.3 Speed Sensing

One of the more important features of this entire project will be a way to sense the speed that the players are going at. The speed of the bicycles will be used to determine the calories being burned by the user, the power being generated by the user, and the distance traveled by the user. This sensor will also be an important method of relaying real-time data about the pedaling speed of the user to our game.

Several ideas were considered for the speed sensor. Initially, we were going to create a circuit which would be closed by a "switch" each time the wheel of the bicycle underwent a revolution. This switch would be a simple metal tab which would make contact with both ends of the circuit, completing it and allowing The circuit would always need to be powered on, and each time the switch made contact with the circuit, a revolution of the bicycle would be counted. By timing how many times the switch was closed in a set amount of time, we would then determine the speed, RPM, power generated, and distance traveled of the bicycles of each user. However, this turned out to be a non-ideal solution. First, we would have to place a metal tab on a moving part of our bicycles, and that

tab would also be continuously under stress due to it being pushed against air and also due to it hitting the leads that it has to act as a switch. This would make it so that the bicycles would have to undergo maintenance at somewhat frequent intervals in order to keep functioning. Therefore, we decided to use a similar concept but with magnets instead of leads that need physical contact. To do this, we will use a hall-effect sensor.

3.3.1 Hall Effect Sensor

Hall Effect sensors are devices which generate a voltage when exposed to a magnetic field of the correct polarity and sufficient strength. The hall effect sensor is based on the Hall Effect, where a potential difference is produced across a conductor when a magnetic field is placed perpendicular to the flow of the current across the conductor. The sensor is made up of a thin, rectangular piece of a p-type semiconductor with a continuous current across it. When a magnetic field is introduced to the sensor, the electrons and holes are pushed to and build up on either side of the semiconductor, creating a potential difference between the two sides of the device called the Hall Voltage. This mechanism is illustrated in Figure 8 below.

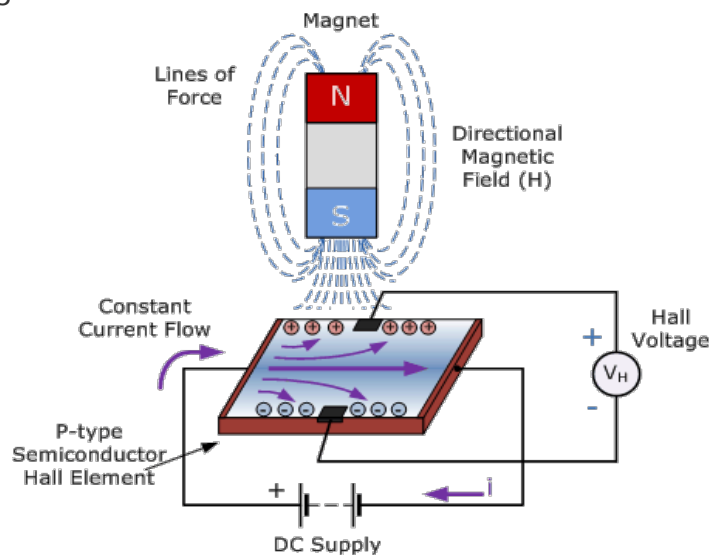

Figure 8. Operation of a Hall Effect Sensor

The hall effect sensor will only turn on if a strong enough magnetic field is introduced. These sensors also output a variable voltage depending on the strength of the magnetic field that is introduced to it. However, for our application we will only need to determine when the wheel of the bicycle is spun one time. Therefore, we will create a circuit where once the output voltage reaches a desired value, the circuit will create a pulse and then turn off until the wheel is spun once again. As illustrated in the image below, a magnet will be placed on the wheel of our bicycle and the sensor will be placed on a stationary

part of it. This will allow us to not have to deal with any messy wiring that must spin, giving our project an overall better design and cleaner look.



Figure 9. Hall Effect Sensor Placement

3.3.2 Hall Effect Sensor Requirements

When selecting a hall effect sensor, several things must be considered. First, the switching speed of the sensor is the most critical aspect. According to Livestrong, the average stationary bicycle user rides at between 50 and 110 rotations per minute. We must consider that this is the average pace and that our users will be undergoing a race for our project, so we will consider the upper end of this range. Since this range is also the average range and not a racing range, we will double it so that we do not run into issues with reaching the sensor's maximum limitations. Therefore, a sensor of at least 200 Hz will be required for this application.

Next, the current and voltage that the sensor produces and uses must be considered. The voltage input to the device will not be an issue as we will have power regulation to the sensor, but the output voltage and required current must be accounted for. For the output voltage, a diode can be used in order to only accept voltage above a certain range from the sensor which can then be counted to track the rotation of the wheel. This will be important as the distance between the magnet and the sensor must still be determined, which changes the output voltage of the sensor. The required current should be as small as possible in order to limit our power losses. Since all of the power used by our system is being generated by the users and stored in batteries, we must be mindful of the energy being used by any and all devices.

Finally, the size of the sensor must be considered. We will be working in a tight space within the stationary bicycles and we also want our final projects to look as refined as possible. Therefore, we will find a sensor that is as small as

possible while being mindful of our other requirements. Below is a table comparing the servos that we considered using for this project.

3.3.3 Hall Effect Sensor Selection

The hall effect sensor is one of the important parts of the system because it will be used to keep track of the distance and speed of the users that will be outputted to the mobile application. When deciding on which sensor to choose, the main factors we had to take into consideration were the power needed to be supplied to run it and the frequency at which it can pick up magnetic pulses. Some other factors that are shown in Table 7 below.

	DRV5053	55140	55100
Item	Analog-Bipolar Hall Effect Sensor	Miniature Flange Mounting Sensor	Miniature Flange Mounting Proximity Sensor
Manufacturer	Texas Instruments	Littelfuse	Littelfuse
Lead Type	Pins	Wires	Wires
Supply Voltage	2.5 to 38V	3.8 to 24V	3.8 to 24V
Output Voltage	-0.5 to 2.5V	Supply Voltage - min voltage	Supply Voltage - min voltage
Operating Temperature	-40C to +150C	-40C to +100C	-40C to +100C
Source Current	0 to 300uA	1.6 to 5.2mA	1.6 to 5.2mA
Sink Current	2.7 to 3.6mA	20mA	20mA
Output Delay	13 to 25us	-	-
Output Frequency	40-77kHz	10kHz	10kHz
Dimensions	2.92 x 2.37mm	-	-
Cost	\$0.44	\$4.50	\$8.84

Table 7. Comparison of Hall Effect Sensors

After analyzing our options, we have decided to go with the 55100 from Littelfuse. Although it is the most expensive sensor found in our list, this sensor will allow us to do everything we need with it right when we get it. It can be easily mounted due to the holes in it and has wire leads which can be used to connect to a circuit farther away from where the sensor will be located, which is ideal. This sensor can also handle up to a 10 kHz switching rate, which is excellent since it allows us to much more accurately track the movement of the bicycle. Figure 10 below is an example of a hall sensor with wire leads.



Figure 10. Hall Effect Sensor

3.4 Generator

The power generation system will consist of a motor and chain attached onto the bicycle's rear wheel or the stationary bicycles only wheel. When the player's pedal, the motor will spin due to the chain connecting the pedaling motion to the motor and will then generate power due to the rotating magnetic field being generated inside of the motor. This power will then have to be combined and converted into an acceptable DC signal to go into our battery and charge it.

3.4.1 AC Generation

For AC generation the common device used is known as an alternator. An Alternator, also known as a sequence generator, is a device in which a metal coil is placed within a rotating magnetic field inducing a current through the coil. The two main parts of an alternator are the armature coil and the rotor. The armature coils remain stationary as the rotor generates a rotating magnetic flux. It is possible to control the frequency at which the current that is generated oscillates. The equation is given by:

$$f = \frac{PN}{120}$$

Where P is the amount of Poles on the rotor and N is equal to the rotations of the rotor per minute or the RPM. In the United States of America, we use 3 phase 60 Hz AC electricity. To get a 60 Hz signal generated for a 10-pole rotor the alternator should rotate at 720 RPM. The typical cyclist will only pedal at about 60 to 80 rpm, so a step-down gear system will have to be implemented in order to reach these kinds of rotation rates from the user. The magnets used in the alternator can either be created by passing DC current through wiring around a core via slip rings and an external source, or the alternator can have permanent magnets. Since the purpose of the Battle of the Bikes is be self-sufficient and generate all of its own power, the permanent magnet alternator would be the ideal choice.

3.4.2 DC Generation

If we are to generate DC current instead of AC, we would need to use a DC generator. A DC generator is not unlike an alternator. A DC generator uses electromagnetic induction to convert mechanical energy to electrical energy. The frame of the generator called the yoke is magnetic and houses the pole core, field coils, armature core, armature windings, the commutator, the brushes and the bearings. Similar to the alternator, the DC generator takes the mechanical energy and rotates an armature core surrounded by the magnetic field coils. There are two types of DC generators, Lap winding and Wave winding. In a lap winding generator, the armature windings the number of parallel paths of windings between poles is equal to the number of poles, which is equal to the number of brushes. This kind of generator produces low voltage, but high currents. Wave winding the number of parallel paths always equals 2. This generates a high voltage and a low current. The wave winding is much more suitable for the uses in the Battle of the Bikes. The commutator is what ensures DC generation. It attaches to the armature and collects the current from the armature conductors. It then inverts the negative flow of the current and ensures that all the current is constantly flowing in one direction, making it into DC current.

3.4.3 Generator Selection

The entire internal system of the Battle of the Bikes will primarily use DC power as that is what will be supplied by the battery. The exception is the added external device charger which must produce a 60 Hz 120V AC signal. However it is not necessary to generate DC electricity as we have ways of rectifying the AC signals to form direct current. Rectifying a generated AC signal is not as efficient

however. A significant power loss will occur if there are too many inverters in the system from AC to DC, DC to DC, DC to AC. For the needs of the Battle of the Bikes a DC generator is the most efficient way to convert the mechanical energy created from the user exercising on the bicycle to the electrical energy needed to power all of the Battle of the Bikes' systems. Specifically a permanent magnet DC generator so that the system does not need an external DC source to simulate a magnetic flux in the generator. This helps keep the Battle of the Bikes a self sufficient product.

Since we will be using DC motors in order to generate power for the system, it is important that we determine the correct specifications for this motor since it will be withstanding a lot of use, and the wiring inside of the motor could also become damaged if there is a power surge that the motor is not designed to handle. We have determined that the maximum power that can be generated by any player to be about 400 watts, so we will need a motor that is capable of handling more than this amount of power. Besides the power rating, we must also determine the size of the motor that we want and the kind of efficiency that it will be running at since it is important to be able to calculate the overall efficiency of the entire system.

Below are the inner workings of a DC motor. Expanding on their earlier explanation in this document, DC motors can also be used to generate power. In a similar fashion to how a current causes the spinning motion in the motor, spinning the motor in turn creates a current that is discharged from the armature into whatever circuit it is connected to. This is again due to the interacting fields from the permanent magnets around the armature and the field created when a current passes through the armature. Since torque is applied to the motor this time, a current is then generated to counterbalance the work that is put in to spin the armature.

Based on these requirements for a DC motor, we have assembled a list below of possible options for motors to use as generators for our bicycles.

Brand	FreeEnergy	Greenery	Greenery Star
Model	SCM4-10135C	1016ZY300	
Size	3.9”X3.9”X3.54”		76mmX153mm
Voltage	12V/24V	12V/24V	12V/24V/48V
Current	16.4 A	16.0 A	16.0 A
Wattage	350 W	300 W	350 W
Rated RPM	2700	2750	750
Cost	\$66.23	\$65.00	\$39.00
Shaft Diameter		12 mm	11.1 mm
Torque		1.04 N.m	1.24 N.m

Table 8. DC Motor Comparison

From the information provided in the Table 8 we decided to go with the Greenery 1016ZY300 generator. It is similar in cost to the FreeEnergy, but slightly cheaper and less wattage. The additional 50 watts are unnecessary and would be a waste in the Battle of the Bikes. The Greenery Star generator while being the cheapest, ended up being manufactured and shipped from China, which is not ideal for our time constraints.

3.5 Battery

There are several types of batteries that will function adequately for the Battle of the Bikes such as, Nickel Cadmium Batteries, Nickel Metal hydride, small; however, there are certain constraints that must be adhered to in order to optimize the design. These constraints include:

Size	12"x12"x12"
Weight	Under 20 lbs
Capacity	24V DC, 8A
Rechargeable	Yes
Temperature Range	0 to 100 degrees F
Cost	Under \$30

Table 9. Battery Constraints

3.5.1 Lithium-Ion Battery

Given these constraints there are still multiple battery types that will work. One such type is probably the most commonly used in newer technology, Lithium-Ion batteries (Li-ion). Li-ion batteries have several advantages:

- Weight
 - Li-ion batteries generally weigh much less than the other types of rechargeable batteries of the same dimensions.
 - For the purposes of the Battle of the Bikes the Li-ion battery need would weigh less than a pound.
- Cost
 - Due to the widespread use of this type of battery there are many manufacturers that produce all sizes and shapes of Li-ion batteries, which allows us to find very cost-effective pricing on them
- Capacity
 - The lithium used in these batteries can store a considerable amount of energy for its size.
 - Typically up to 150 Wh/Kg
 - Voltage max depends on the amount of cells
 - Typical Li-ions can handle 4.2V per cell
- Lifespan
 - Li-ion batteries only lose roughly 30% of total charge every 6 months while idle
 - The battery type can handle up to 500 charge cycles at 4.2V per Cell

- A charge cycle is defined as a full charge, full discharge and then another full charge.
- The lifespan can be significantly reduced if a cap limit is placed on the cells however
 - You can double the cycle life of a Li-ion battery if you limit the peak charge by a factor of 0.1V per cell
 - By reducing the peak voltage to 3.9 V per cell you can increase the cycle life from 500 to up to 4000 cycles.

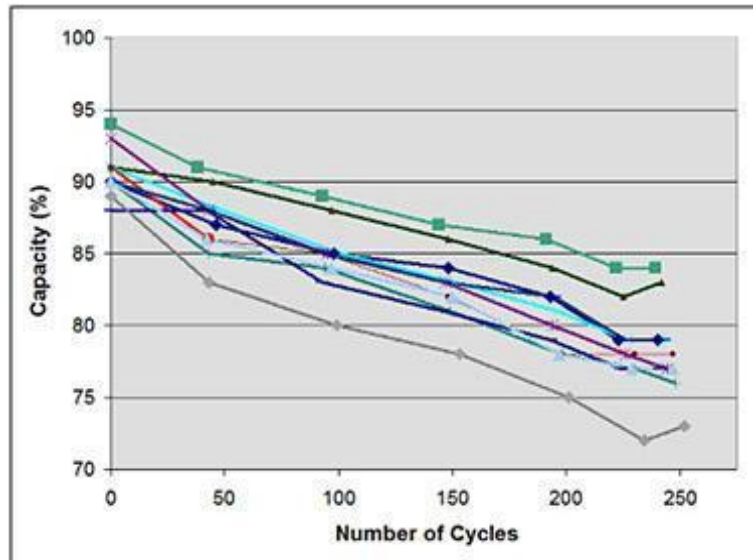

Figure 11. Lithium Ion Battery Capacity vs Cycles

Some of the notable disadvantages include:

- Lifespan
 - Only last up to 3-5 years regardless of if kept in ideal conditions or not
- Temperature
 - They do not respond well to high temperatures, causing them to degrade rapidly as temperature increases

Temperature	% of 40% Max Charge After 1 year	% of 100% Max Charge After 1 year
32°F	98%	94%
77°F	96%	80%
104°F	85%	65%
140°F	75%	60%*

Table 10. Lithium Ion Battery Capacity Over Temperature

* after only 3 months

Related to the temperature of the batteries, there have been incidents where Lithium-Ion batteries have failed and combusted into flame, giving them a unique added safety hazard to consider.

3.5.2 Sealed Acid Battery

Another plausible battery type is the Lead Acid Battery, specifically the Sealed Lead Acid Battery (SLA). The lead acid battery was the first rechargeable battery introduced to be used for commercial production. There are multiple sub categories of sealed acid batteries, however the two to be considered for the Battle of the Bikes are the valve-regulated lead acid (VRLA) and absorbent glass mat (AGM). Advantages of Sealed Acid Batteries:

- Cost Effective
 - Similar to the Li-ion batteries, the SLA comes in various sizes and capacities from many manufacturers allowing for cost effective means of obtaining them
- Charge
 - Among all the types of rechargeable batteries, SLAs have the lowest rate of discharge when idle
 - Capable of high voltage and ampere discharge compared to other rechargeable battery types
- Lifespan
 - If kept in ideal conditions, some SLAs can last up to 10 years
 - Depending on conditions they can last anywhere from 500-2000 cycles

Disadvantages of Sealed Lead Acid Batteries:

- Temperature
 - The ideal temperature is at room temperature, roughly 77°F.
 - Every 15°F rise in temperature cuts the batteries expected life in half
- Weight
 - Lead acid batteries are heavy, that is for the purposes of the Battle of the Bikes would weigh in the 5-10 pound range

3.5.3 Battery Selection

Each kind of rechargeable battery has its advantages and disadvantages when compared with the others, but after comparing and contrasting each to the specifications of the Battle of the Bikes we have decided to implement the SLA, AGM type battery. The choice comes from its overall versatility. The Sealed Lead Acid AGM battery can perform and be stored in any climate the Battle of the Bikes might be set up in, whether that be inside a controlled environment or outside on the users porch the temperature range of the SLAs peak performance will not be affected. It can store the required amount of power for the system and not have to be fully charged while being stored. The Li-ions superior power to weight ratio is ideal for supplying all of the power to the Battle of the Bikes while maintaining a minimal size for the control unit was considered, but ultimately the Li-ions price outweighed its power to weight ratio. The wide availability of this battery type also makes it a convenient option. The lifespan of the Li-ion is not as perfect as the SLA either, so the SLA AGM battery will be able to last longer.

	Lithium Ion	Sealed Lead Acid
Advantage	-best power to weight ratio	-High Wattage capability -Low cost
Disadvantage	-Expensive -need to connect multiple batteries to get desired Amps	-Large and heavy compared to Li-Ion
Comparison Points	-1	1

Table 11. Battery Type Comparison

Based on the comparison for the two battery types, for the purposes of the Battle of the Bikes, the team decided on using a Sealed Lead Acid Battery. Due to its high amperage and low cost, while being able to maintain a constant 12V DC this battery type is the preferred choice. The size and weight, while at the high end of our requirements, still fit within the parameters and therefore will not affect the overall design of the system.

Brand	Kinetik	UPS Battery	Keyko
Model	APIX30L		KT-12200
Voltage	12V	12V	12V
Amp Hours	30 Ah	22 Ah	20 Ah
Weight	20.5 Lbs	12.65 Lbs	11.51 Lbs
Size	6.6"x5"x6.9"	7.13"X3"X6.59"	7.19"x3.06"x6.63"
SLA Type	AGM	AGM	AGM
Cost	\$81.99	\$74.99	\$42.95

Table 12. Battery Comparison

Based on the data provided in the Table 12 the specific battery chosen is a Sealed Lead Acid by Keyko called the Keyko EV-Rider MiniRider 12V 20Ah Battery with model number KT-12200. This battery provides sufficient voltage and amps for the Battle of the Bikes while keeping the size, weight, and cost to a minimum compared to the other batteries researched.

3.6 Microcontroller

Many current microcontrollers share many of the same features. These features include processors that range from 4-bit to 64-bit and use RAM, flash memory, EPROM and EEPROM to store information into memory. The microcontrollers have sufficient memory and pins for I/O operations, so they are readily usable when purchased. The microcontroller(s) for the Battle of the Bikes will be used to interface with the different components of the system and run mathematical calculations used for outputting stats to the user.

The microcontroller(s) will take user inputs for the game setup and use and revolutions of the tire on each stationary bike as inputs. These inputs will include the user's weight and the distance that they are going to ride for this use. The microcontroller will use the input from each bike and user to calculate the caloric loss, distance travelled and current/average/top speed for each user. These

calculations will be saved to memory to be sent as output to the user later when the game is finished. During use, the system will output certain parameters to the display such as, current distance travelled by each user and whether or not either user has a power up to use and at what level strength. Based off how we choose to display information to and take information from each user, the system will send information while it is in use in different ways. If we decide to use a LCD to display information to the user, the microcontroller will forward the data to the LCD to display the data in a clear and easy to read fashion through the use of a direct connection by wires from the microcontroller to the LCD. If we decide to create an app on a phone, the microcontroller will use the wireless transmitter that is either on the board, or integrated to it, to send data to, and receive data from, the user's phone.

Inputs (Setup)	Distance for game
	Weight
	Tension
Inputs (During Use)	Tire revolutions
	Use of power-up
Outputs (During Use)	Distance travelled by both users
	Current speed of each user
	Power up (if any) for each user
Outputs (When Completed)	Time to complete distance goal
	Average and top speed
	Calories burned

Table 13. List of inputs and outputs for system

3.6.1 Types of Microcontrollers

There are many microcontrollers that can be used for this project. We are looking for a microcontroller that can do very basic calculations and can send, and receive, information quickly between itself and the stationary bike. It must

also have the capability to communicate wirelessly if our team decides to implement wireless communication in our final system. When making a decision between all the options, our main focus will be on the following:

- Cost
- Compatibility
- Ease of programming
- Specifications

Some of the better known microcontroller families are ATMEL AVR, Texas Instruments MSP, and Microchip Technology PIC. These microcontrollers are very similar and we will take into consideration the list above when making our decision.

3.6.1.1 Atmel AVR

The Atmel AVR is a modified Harvard architecture machine, which means that the program and data are stored in separate physical memory systems that are in different memory address spaces, but has the ability to read data items from program memory using special instructions. It is an 8-bit RISC single-chip microcontroller and was one of the first microcontroller families to use on-chip flash memory for program storage. Atmel has many microcontrollers ranging that meet special purposes. The ATmega series is one of the most popular and widely used series that Atmel creates. This series features a range of 4-256 KB program memory, 28-100-pin package, extended instruction set, and an extensive peripheral set.

The ATmega series is divided up based on the size of program and data memory. These microcontrollers are desirable for our system because they have a platform for programming and development which makes interaction with the board simple. Table 14 shows a breakdown of the different ATmega options:

Microcontroller	Program Memory	SRAM	EEPROM
ATMEGA48	4 kB	512 B	256 B
ATMEGA88	8 kB	1 kB	512 B
ATMEGA168	16 kB	1 kB	512 B
ATMEGA328	32 kB	2 kB	1 kB

Table 14. ATMEGA series chip memory comparisons

Based on specifications of each, the ATMEGA328 would be the best option for our system. We believe this because it offers the most memory out of all the microcontrollers listed, 23 general purpose I/O lines, 32 general purpose registers, 3 flexible timers with interrupts, and multiple power saving modules while still being very inexpensive at only a few dollars. Having the power saving option is a high priority for us because we want our system to consume as little power as possible during use. The parameters of the ATMEGA328 are shown below:

	Program Memory	SRAM	EEPROM	Voltage	Speed
ATMEGA328	32 kB	2 kB	1 kB	1.8 - 5.5 V	20 MHz

Table 15. Specifications for chosen microcontroller

3.6.1.2 Arduino

The Arduino platform is an open-source electronics platform based on easy-to-use hardware and software. Arduino boards are able to easily read inputs and generate an output. The platform gives the user an IDE to program the board. Having an IDE to program the Arduino board is useful because it allows the programmer to make changes much easier than if the programmer did not have a platform to program it in. To program the Arduino board, you have to use the Arduino programming language, which happens to be C/C++. And since the Arduino board has a USB interface, the programmer can connect the board to his/her computer to program the board. There are many advantages to using the Arduino platform:

- Inexpensive
 - Having an inexpensive platform to work with the microcontroller is one of the goals for this project. Pre-built boards can be bought for under \$50.
- Cross-platform
 - The Arduino Software runs on Windows, Macintosh OSX, and Linux operating systems.
- Simple programming environment
 - Easy environment to learn in for first time users.
- Open source software and hardware
 - Can find many designs and implementations online for referencing.

The Arduino board offers all the specifications needed for this project such as USB interface for easy programming, allows attachments for wireless communication, and 5V for powering itself. Some boards also have built-in wireless communication.

3.6.1.3 Texas Instruments MSP

Texas Instruments is one of the biggest, well-known companies in the market. While not notably known for their microcontrollers, Texas Instruments has a wide variety of different options for their microcontrollers that can fit the need of any small-project engineer. These microcontrollers are also appealing because Texas Instruments also has an IDE that makes interaction with the microcontroller much easier for the programmer. Texas Instruments splits up their microcontrollers into three sub-groups: low power, performance, and wireless.

Obviously, the low power group is known for using very little power when it is being used. These microcontrollers combine smart analog with low system energy to fit any power budget. Some key features of this group are as follows:

- World's only embedded FRAM MCU family
- Broad range of applications such as smart grid, wearables, sensors and energy harvesting

The performance group, however, is known for having the best performance, throughput, standards. This group specializes in control loop and functional safety applications. Some key features of this group are as follows:

- Experts in applications for motor control, industrial drives, digital power and transportation
- Support for functional safety standards like IEC 61508 and ISO 26262

The last group is the wireless group. This group is known for being able to communicate wirelessly with other devices. This group specializes in connecting the world one product at a time with low-power wireless MCU solutions. The key feature of this group is:

- Utilize multiple protocols such as Sub-1 GHz, NFC, Wi-Fi, Bluetooth, Bluetooth Smart (Bluetooth low energy), 2.4 GHz and ZigBee

With the wide array of options of groups at hand, and with an extensive amount of microcontrollers in each of those groups to choose from, Texas Instruments makes it easy to find a microcontroller to fit any project. Table 16 shows a breakdown of the different Texas Instruments options:

Microcontroller	Frequency	Program Memory	SRAM	Price
MPS430FR6989	16 MHz	128 KB	2 KB	\$4.50
MSP430F6779	25 MHz	512 KB	32 KB	\$6.76
CC430F6147	20 MHz	32 KB	4 KB	\$3.20

Table 16. Texas Instruments microcontroller comparisons

Based on specifications of each, the MSP430FR6989 would be the best option for our system. We believe this because it offers the most memory out of all the microcontrollers listed, 83 general purpose I/O lines, 5 16-bit flexible timers with interrupts, and runs at super low power. Having the power saving option is a high priority for us because we want our system to consume as little power as possible during use. The parameters of the MSP430FR6989 are shown below:

	Program Memory	SRAM	Voltage	Speed
MSP430FR6989	512 KB	32 KB	1.8 V - 3.6 V	25 MHz

Table 17. Specifications for chosen microcontroller

3.6.1.4 Microchip Technology PIC

The PICs are a series of chips that were created by Microchip Technology. The PIC microchips have a RISC architecture and are designed with a Harvard architecture, which means that the program and data are stored in separate physical memory systems that are in different memory address spaces, but has the ability to read data items from program memory using special instructions. The PIC microcontrollers appeal to many hobbyists and experimenters in the fields of electronics and robotics. Key features of the PIC microcontroller are wide availability, low cost, ease of reprogramming with built-in EEPROM, an extensive collection of open source material, and abundant development tools.

Throughout the years, Microchip Technology has been expanding the size of the PICs from 12-bit when they began to now 32-bit. Table 18 shows a breakdown of the different Texas Instruments options:

PIC	Program Memory	Frequency	Data Memory
18F252	32 KB	40 MHz	256 B
32MX360F512L	512 KB	80 MHz	32 KB
32MM0256GPM064	256 KB	25 MHz	32 KB

Table 18. PIC microcontroller comparisons

Based on specifications of each, the 32MM0256GPM064 would be the best option for our system. We believe this because it offers a large amount of memory, 32 general purpose I/O lines, 16-bit flexible timers, and runs at low power. Having the power saving option is a high priority for us because we want our system to consume as little power as possible during use. The parametrics of the 32MM0256GPM064 are shown below:

	Program Memory	SRAM	Voltage	Speed
32MM0256GPM064	256 KB	32 KB	2 V - 3.6 V	25 MHz

Table 19. Specifications for chosen microcontroller

3.6.1.5 Raspberry PI

Raspberry PI is not technically a microcontroller, but instead it is a full-fledged, low-power computer. The Raspberry PI was developed in the United Kingdom by the Raspberry PI Foundation to promote teaching basic computer science in schools and developing countries. Although the Raspberry PI is slower than modern computers, it is still a complete Linux computer and provides all the expected abilities of one at a low-power consumption level. Although the default firmware is closed source, there is an unofficial open source available.

It provides several on-board features such as networking, peripheral connection, and video display. The board runs on Raspbian, which is a Linux distribution, and can be programmed in Python and Scratch. All of the software that the Pi can use is either free or open-source, allowing for great ease of learning from others who have also used the software for the Pi. The Raspberry Pi is also very small and cheap, fitting in the palm of your hand and costing about 30\$. It also has GPIO pins to interface with any external devices and has a modular interface that is highly customizable, and provides functionality for USB.

The most recently released Raspberry PI model is the Raspberry PI 3 Model B. This model has a 64 bit quad core processor, onboard WiFi, Bluetooth and USB

boot capabilities. The processor runs at 1.4 GHz and has a gigabit Ethernet or 2.4 / 5 GHz dual-band WiFi.

Raspberry PI Model	SRAM	Power Rating	Price
Model B 3+	1 GB	1.13 A (5.661 W)	\$35
Zero W	512 MB	350 mA (1.75 W)	\$10

Table 20. Raspberry PI model comparisons

Based on specifications of each, the Zero W would be the best option for our system. We believe this because it is an extremely low-power consuming computer with wireless capabilities. Having low power consumption is a high priority for us because we want our system to consume as little power as possible during use. The parametrics of the Zero W are shown below:

	RAM	CPU	Wireless
Zero W	512 MB	1 GHz, single-core	2.4 GHz

Table 21. Specifications for chosen microcontroller

3.6.2 Choice of Microcontroller

The microcontroller that we decided to go with was the Arduino that incorporates the ATMEGA328. We chose this as our microcontroller for many reasons. First, the Arduino has a platform and an extensive library for us to program the microcontroller with ease. It is a platform that is easy enough for first-time users to learn on and yet powerful enough for experienced programmers to work with. Arduino is also open-sourced, so we are able to look up documentation for many projects that are similar to ours in any way to help in the design process. Also, if our group has a problem with creating our own wireless communication, the Arduino has many different modules for us to choose from to implement wireless communication with external devices. Also, the Arduino relatively inexpensive for all that it offers and has low power consumption which is a main feature we must consider during the creation of our project.

3.7 Display

3.7.1 Liquid Crystal Display

LCDs are used by microcontrollers to output information to users. LCDs have many desirable attributes for our system such as low power consumption, no distortion of output on the screen, and come in many sizes to fit the user's needs. The common sizes of many of the LCDs are 8x1, 16x2, and 20x4.

The purpose of the LCD in this project would be for displaying relevant information to the user during, and at the end of, each use. The LCD provides a basic output of information for the user to view. Each user will have a LCD on their bike to keep track of stats during use and to see stats when the game is completed. The LCD will take inputs from the microcontroller while the system is being used and display the following on the LCD:

- Distance travelled by the user
- Current speed of the user
- Power up, if the user has one

When the game has come to a conclusion, each user will also be presented with the following stats based off of how they rode during use:

- Whether the user won or loss
- The time to ride the distance that was set
- The user's average and top speeds during use
- The Calories burned from the ride

3.7.1.1 Hitachi HD44780

Hitachi HD44780 displays commonly have 16 input connections and accept data in parallel format. This LCD also has multiple modes to use - 4-bit and 8-bit. There are many desirable features of this LCD such as choice of size of LCD, low power to operate, and a wide range of instruction functions.

3.7.1.2 The Arduino and HD44780

The Arduino board has a built-in library called LiquidCrystal that is used to control the LCD. The library works with both 4-bit and 8-bit modes of the HD44780. This library makes working with the LCD display extremely easy. This library removes the need to do any low-level programming because the Arduino board is written in high-level languages C/C++ and the library does all the low-level work for the programmer.

3.7.2 Touchscreen

For our Battle of the Bikes system, we are faced with the decision of choosing between a standard LCD display and a touchscreen display. The main difference when picking between the two is the functionality of the overall system. If a standard display is chosen, then the game will have to run from an app on the user's phone, or some form of switch or button will have to be incorporated into the game in order for the players to pick the distance that they want to cycle for as well as to use their power-ups. If a touch-screen is chosen, then we can bypass creating a phone application and instead focus our programming efforts purely on game design. A touch-screen would also allow for more interactivity with the user since everything necessary to interact with the bicycle would be presented to the players upfront instead of requiring an app download to function. This would also eliminate the need to communicate with any cell phones, further simplifying the circuits that need to be created for wireless communication and input processing. We are then faced with the choice of creating our own touchscreen or using one that is already made for the microcontroller that is chosen.

3.7.2.1 Resistive

Resistive touchscreens function by closing a circuit between two conductive layers when they are pressed down as shown in the image below.

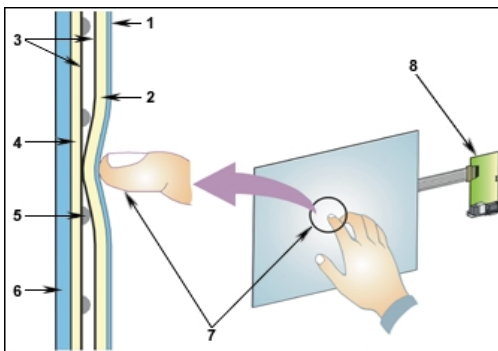

Figure 12. Operation of a Resistive Touchscreen

A small gap is formed by many spacers placed throughout the screen, which is used to keep the two layers apart until they are touched. Of the two layers, one is conductive, and one is resistive and there is always a current through them. When touched, the circuit is complete and the current changes where the finger touched the screen, which can be measured and manipulated with software. Although resistive touch screens are consistent, they are hard to read due to having multiple layers and are also incapable of handling multiple touches.

3.7.2.2 Capacitive

On the other hand, capacitive touchscreens can function with any object that can hold a charge. Capacitive touchscreens are comprised of a grid of tiny wires that induce a capacitance throughout the screen. When you place your finger or an object that holds a charge on the screen, charge is transferred from the screen to the object, lowering the capacitance of the screen. Sensors placed at the corners of the screen detect this change in capacitance and allow for the touch to be pinpointed by software. The following image illustrates this in action:

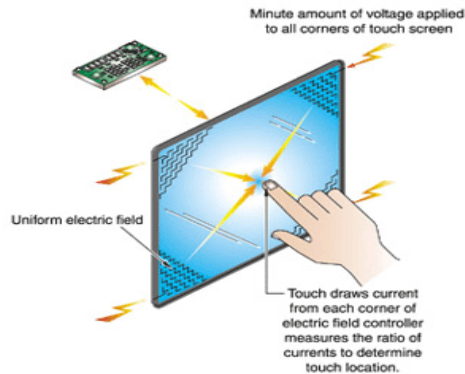

Figure 13. Capacitive Touch Sensor Operation

There are two main types of capacitive touchscreens: surface and projective. For surface capacitive screens, the screen is very durable and resistant to liquids, but it can only be interacted with human skin or specially designed styluses that hold charge. For projective capacitive screens, an embedded electrode film that creates a 3D electrostatic field. This allows for multi-touch functionality of the screen, but also makes it subject to more interference from other electromagnets or even radio frequency.

3.7.2.3 Measuring Change in a Touchscreen

There are two available methods in order to actually determine where the user touches a capacitive touchscreen: RC time constants and frequency shifts.

When using RC constants, the sensor is first charged up to a logic high and discharged through an input pin. This allows for the charge to be dissipated in a slow enough time to be detected by the controller. When the sensor is touched, an additional capacitance is created on the sensor, increasing the time constant as illustrated in the picture below.

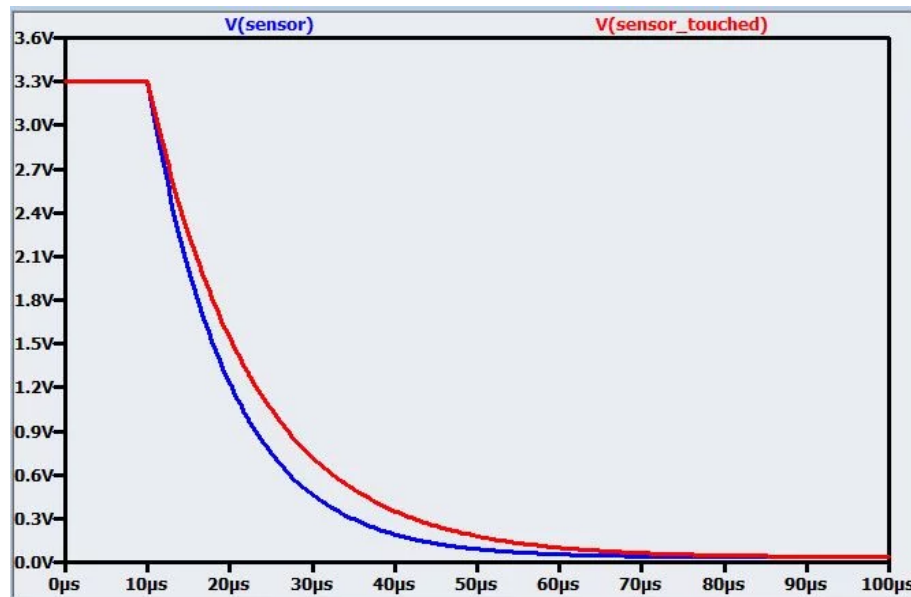

Figure 14. Touch screen time constant

Although this is not a huge change in the time constant, it is enough to detect with a microcontroller. Therefore, the main principle behind this type of touch sensor style is to repeatedly charge and discharge capacitors and measure the time taken to discharge each time, which will then allow for the controller to detect a touch.

In order to detect a touch with frequency shifts, a capacitive sensor is used in an RC oscillator, changing the frequency when the capacitance is changed. A counter counts the number of edges that occur in a specified period during the charging and discharging of the capacitors. When the screen is approached to be touched, the capacitance of the sensors are increased, which in turn decrease the frequency of the oscillation as well as the frequency of the edges being counted.

3.7.3 Touchscreen vs LCD

We must now make a decision of whether to use a touchscreen or an LCD display for our project. Both have their pros and their cons, but one will be much easier to work with in the long run. Initially, we wanted to create our own screen to use for the project in order to learn the process of creating a screen. However, this is very difficult to do with a touchscreen in the allotted time that we have, and it would also increase the power draw of the overall system.

Next, we tried the idea of making our own LCD. However, this is also impractical as each segment of the LCD has to be individually made, which would either leave us with a lot of work to create many segments, or we would have a very small resolution on our display. This also involves repeatedly using very thin,

fragile materials and running electricity through them, which could quickly become a problem us since we have no experience doing this.

3.7.4 Comparison of LCDs and Choice

	Touchscreen	LCD
Resolution	High	Low
Availability	High	High
Price	High	Low
Compatibility with Project	Can display game and information simultaneously	Requires mobile device for game

Table 22. Comparing Touchscreens and LCDs

If our group decides to implement an LCD into our design, the choice was clear in that we will use the HD44780. The creation of our own LCD screen would cost far greater and take much more time to implement than if we were to just purchase one. And once again, the Arduino has a library that would make working with the LCD very easy. The library has prewritten functions to get the LCD initialized and display whatever the programmer wants.

4. Design Constraints and Standards

4.1 Project Constraints

There are a few possible constraints that our project could run into when designing it. One possible constraint would be the motor being used to apply tension to the bicycle. We have to choose a motor that has enough power to apply tension to the bicycle, but also not be too loud to disturb the gym goers. Also, depending on how the motor is implemented, we would have to worry about its durability. Durability may not only mean the motor burning out based off how we decide to implement it. For example, if it is used as a rubber stopper like the brakes on a normal bike, we need a material that will be able to hold up for a long time. Another constraint could be the cost of the materials needed in the project. As a group, we do not have a lot of money to throw into this project, and we do not have any sponsorships to help pay for parts, so we may be

limited on what we are able to buy. As we research more and begin building the project, there will likely be more constraints added to this list.

4.2 Requirements and Specifications

For the Battle of the Bikes, we will be using the mechanical energy created by the user to ultimately drive the entire system. In order to do so, we will have a 12-volt battery as a power source to initialize the system to allow the user to start the game. The user at this point can select how far they want to ride for their workout. Then, when the user begins pedaling the bike, the mechanical energy that is created will be passed to a power converter in order to recharge the battery power supply. This battery will be used to power all the electrical parts of our system, including a charging station for a mobile device. We will need a DC-AC inverter to convert the battery, 12-volt DC, to an AC source to power all the electronics.

On average, a typical biker can generate 100 Watts of power in one hour of riding (michaelbluejay). During short bursts, it is possible to generate upwards of 400 Watts when pedaling as fast as the user can. So to not waste the energy that the user is putting into the system, we would want a DC converter with a max power output of at least 400 Watts. The specifications that we are putting in place are to keep our losses at a minimum and allow our system to be as efficient as possible.

Specification	Value
Power Input	12V DC, up to 400W
Power Output	120V 60Hz
Speed	35MPH max

Table 23. Requirement Specifications

4.3 Standards

4.3.1 Wireless Communication

4.3.1.1 IEEE 802.11

IEEE 802.11 is a set of media access control and physical layer specifications for implementing wireless local area network computer communication in the 900 MHz and 60 GHz frequency bands. These standards are the world's most

widely used wireless networking standards, used in most home and office networks to allow intercommunication between laptops, smartphones and printers and to allow them to connect to the Internet without the use of wires. These standards were created by the Institute of Electrical and Electronics Engineers LAN/MAN Standards Committee. There have been many updates to these standards throughout the years due to the new capacity of technologies.

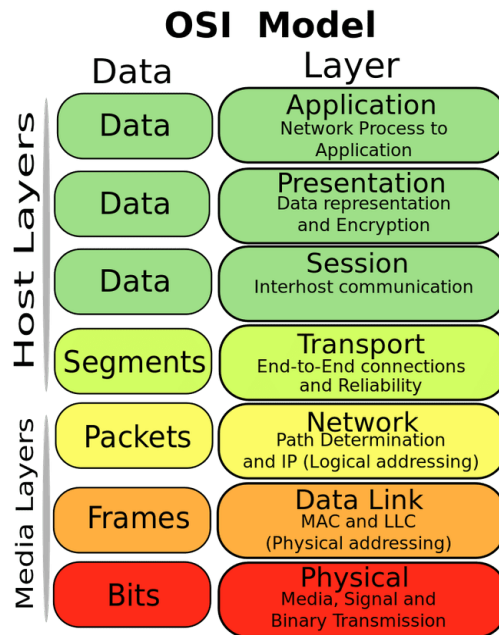

Figure 15. The OSI Model

4.3.1.1.1 The Media Access Control Layer

The media access control sublayer and the logical link control sublayer make up the data link layer, which is the second layer of the Open Systems Interconnection model. The logical link control sublayer provides flow control and multiplexing for the logical link. The media access control sublayer, however, provides flow control and multiplexing for the transmission medium. According to IEEE, the primary functions of the medium access control layer are:

- Frame delimiting and recognition
- Addressing of destination stations
- Conveyance of source-station addressing information
- Transparent data transfer of LLC PDUs, or of equivalent information in the Ethernet sublayer

- Protection against errors
- Control of access to the physical transmission medium

The addressing mechanism of the media access control layer is based off an addressing scheme used by early Ethernet implementations. A MAC address is intended to be a unique serial number and they are typically assigned to a network interface hardware at the time on manufacture. The most significant part of the address identifies the manufacturer while the rest of the address provides a unique address for that specific hardware. This MAC address makes it possible to deliver frames on a Wi-Fi network from one device to another through the use of repeaters, hubs, bridges, and switches. The frames know where to go by using the MAC address as their destination location.

Another mechanism in the medium access control layer is the channel access control mechanism, also known as multiple access protocol. This protocol allows multiple stations connected to the same physical medium to share it. The multiple access protocol may detect and avoid packet collisions if a contention based channel access method is used.

The medium access control layer also makes the decision of which device gets to transmit at which time and for how long. As a wireless network, Wi-Fi is expected to have packet loss frequently so there needs to be a way to know when there is a loss so that the network can correct it. To keep this in mind, the medium access control layer uses carrier-sense multiple access with collision detection (CSMA/CD). CSMA/CD uses carrier-sensing to defer transmissions until no other stations are transmitting. Collision detection is used in combination with carrier-sensing as well so as to know when a collision condition is detected so the station stops transmitting the frame and waits a certain time interval before it tries to send the frame again. This transmission technique is useful because it greatly lowers the time to resend a packet.

4.3.1.1.2 The Physical Layer

The physical layer is the first layer in the Open Systems Interconnection model. This layer consists of the electronic circuit transmission technologies of a network. Because there are so many hardware technologies available, this can be considered the most complex layer of the Open Systems Interconnection model. The physical layer defines the means of transferring raw bits and signals rather than logical data packets over a physical data link connecting network nodes. Since we will be using a wireless network, there is only a certain data rate we can reach. The max data rate will correspond to Shannon's Capacity/Data Rate Equation, which is as follows:

$$\text{Max Data Rate} = \text{Bandwidth} * \log_2\left(1 + \frac{\text{Signal Power}}{\text{Noise Power}}\right)$$

4.3.1.2 IEEE 802.15

Bluetooth is a low-data-rate, low-power wireless network standard that is used to replace the need for wired connection between different lightweight devices. IEEE 802.15.1 is a set of specifications for using Bluetooth wireless communication. The Bluetooth protocol stack is different from many other IEEE networking stacks because it defines many components above the physical layer and the medium access control layer, some of which are optional. Figure 16 shows the Bluetooth protocol stack:

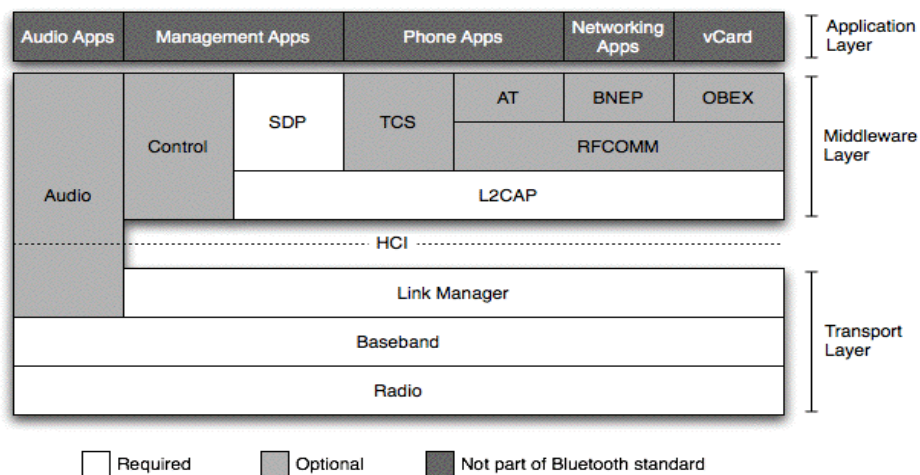

Figure 16. The Bluetooth Protocol Stack

4.3.1.2.1 Transport Layer

The Bluetooth transport layer is almost equivalent to the OSI physical and medium access control layers. All Bluetooth devices must implement this layer in the hardware. The transport layer is composed of the radio, baseband, and link manager layers.

4.3.1.2.1.1 Radio Layer

The radio layer dictates the frequency, power, and modulation used by the Bluetooth antennas. Bluetooth occupies 79 channels at 1 MHz each in the 2.4 GHz spectrum. Devices only use one channel at a time, and hop between channels as needed. There are also guard bands at the end of either end of the spectrum. All Bluetooth devices use binary phase shift keying modulation; this offers a maximum data rate of 1 Mbps. The Bluetooth receivers are required to have a bit-error rate of 0.1% or less.

Bluetooth devices are divided into three classes, which specify the antenna's output power. The classes are broken down in Table 24:

Class	Class 1	Class 2	Class 3
Power Usage	1 mW to 100 mW	0.25 mW to 2.5 mW	up to 1 mW
Range	100 m	10 m	1 m

Table 24. Classes of Bluetooth

4.3.1.2.1.2 Baseband and Link Layers

At the baseband layer, Bluetooth devices form into piconets and/or scatternets. Piconets consist of one master device that communicates directly with up to 7 active slave devices. Piconets can also have up to 250 inactive slave nodes at any given time. Multiple piconets can be combined into a single multi-hop scatternet.

Communication within a piconet occurs directly over the one-hop link between a master and slave. The slaves cannot communicate directly with each other. Bluetooth uses a basic time-division duplexing scheme, where time is divided into many 625 μ s slots. The master may communicate with a slave during odd-numbered slots, and the slaves can respond during the even-numbered slots. Each packet can consume 1, 3, or 5 slots. After each packet, the piconet hops to a different Bluetooth channel.

Bluetooth has three power-saving modes. In hold mode, devices only handle slots reserved for synchronous links and sleep the rest of the time. In sniff mode, the device stays asleep most of the time, waking up periodically to communicate. In parked mode, the device shuts down its links to the master device, excluding the PSB link. The master device can wake up inactive devices by beaconing them over the PSB link.

4.3.1.2.2 Middleware Layer

The middleware layer consists of several software components that are designed to allow interoperability among different Bluetooth devices. Many of the components in this layer are optional. The components of the middleware layer interact with the transport layer through the use of the Host Controller Interface. Some of these components include:

- Logical Link Control and Adaptation Protocol (L2CAP): provides TCP- and UDP-like features to ACL links
- RFCOMM: emulates IrDA infrared links on top of L2CAP

- Telephony Control Protocol Specification (TCS): controls phone operations
- AT: controls phone operations using the legacy Hayes ("AT") command set
- Bluetooth Network Encapsulation Protocol (BNEP): encapsulates Ethernet packets in Bluetooth packets
- Object Exchange Protocol (OBEX): supports IrDA's object synchronization features

4.3.1.2.3 Bluetooth Security

Bluetooth uses a pairing process to establish a connection with encryption and authentication between two devices. The pairing process is performed using a series of keys as an input to the SAFER+ block cipher. In the first stage of the pairing process, the devices generate an initialization key. Then, the devices use the link key to perform a challenge/response protocol. After this, any further communication is optionally encrypted.

4.3.2 C Language Coding Standards

4.3.2.1 Names

Names are the heart of all programming languages. The biggest thing the programmer has to take into consideration is to name everything appropriately. If you give things vague names, years from the time you wrote the code, you will not remember what that name is actually for.

When it comes to functions, functions are something that normally perform an action in your code. So, when naming a function, make sure it is clear what it actually does and that anyone can look at the name and have a general idea of what the function is doing. Since functions are what perform actions in your code, it is helpful to have a verb in your function name. Using prefixes and suffixes can also help give a more in-depth name to explain your function.

When structuring names, it is helpful to either use camelCase or to use underscores when there are multiple words in a name. When you separate the words in a name with underscores, or use capital letters to start the next word, it makes it much easier to read the names. It is also much easier to read through the code when you line up the same data types instead of changing between different types.

When using global variables or constants, be sure to label them to where it is obvious that it is a global variable. That can either be in the form of putting "g_" before the name or actually writing out "global" as an indicator.

When using enums, to make it extremely clear that you are using an enum, use all capital letters to name each enum and separate multiple words with underscores.

4.3.2.2 Formatting

When writing code, the programmer should consider screen size limits and should not exceed 78 characters on a single line. The reason for this is that when reading through code, you should not need to scroll the window to be able to see all of the text. The argument can be made that we can adjust the size of our windows to see more characters per line, however you cannot do the same with printing code. Also, if you make your windows wider, you cannot have as many windows on the screen at the same time, and more windows is better than wider windows.

When using braces, the programmer must be consistent with when and where they place their braces. When placing braces, the opening brace should be on the same line as function and structure declarations, if, else, do, while, and for loops and the closing brace should be on a new line after the last line needed in the loop or declaration. This method of using the braces uses less lines of code overall and shows the programmer exactly where each part starts and ends. The only time this method increases the number of lines in the code is when a loop only has a single statement. However, I find using the braces saves the programmer time later if they find out they need to add more to that loop in the code.

When using parentheses next to keywords and functions, always add a space between for keywords, but not for functions. Adding the space allows the person reading the code to distinguish whether the line they are reading is a function or a keyword.

When writing if-else statements, continue to use the bracing styles that were mentioned earlier. Putting an else or else-if on the same line as the closing bracket from the earlier statement compacts the code too much and makes it hard to read. By putting the else or else-if on a new line, it spreads the code out to increase the readability of the code.

When writing switch statements, the programmer must be careful to not allow falling through and accidentally enter a state that they did not mean to enter. If the programmer wants the fall through, they must provide a comment stating that the fall through was on purpose. Also, there should always be a default case to trigger an error if it should not have been reached.

The use of continue and break should be limited and only on a must-have basis. Problems the programmer must keep in mind when using continue statements are that it may bypass the test condition and it may bypass the increment/decrement expression. Also, never put a continue and a break statement in the same block of code.

Unless statements are very closely related, there should only be one statement per line. When declaring variables of the same type, it is fine to put multiple of the same line, but do not try to mix variables like char * and char **. The reason for this is so that documentation can be added for the variable on the line, it is clear that the variable are initialized and declarations are clear which reduces the probability of declaring a wrong type for a variable.

If the programmer decides to declare a variable, they must initialize to be used later. Also, if the programmer declares, or declares and initializes, a variable, they must use it later in the program. If the programmer never uses the variable, it should be deleted immediately so as to not waste space.

When writing functions, the programmer should keep them short. The length of a function should be no longer than a single page. The idea of functions is to do a single task and so each function should not be very long. This also helps with readability and traceability of code.

4.3.2.3 Documentation

Comments should tell a story. As a person traces through the code, they should know what each function does altogether and what is happening at individual steps throughout the function. This allows the reader to know what should be happening and they can test it to see if it is working how the programmer said it should work.

Each time the programmer had to make a decision in the code, they should place a comment describing the choice they made and why. This will help anyone reading their code understand why they did what they did and understand their thought process.

For each entity in the code, programmers should have two, or three, types of descriptions, which together will form the documentation for that entity. Those descriptions are: a brief description, detailed description, and an in-body description. A brief description is a short one-liner, while a detailed description is longer and more in-depth. The in-body description can also act as a detailed description or can describe a collection of implementation details.

When formatting gotchas, there are a few things to consider. The gotcha keyword should be the first symbol in the comment. Also, comments may consist of multiple lines, but the first line should be sufficient on its own.

4.3.2.4 Complexity Management

Layering is used for reducing complexity of a system. The system should be divided into layers and each layer should be able to communicate with adjacent layers. If a layer tries to communicate with a layer that is non-adjacent, then a violation will occur.

4.3.2.5 Miscellaneous

After the programmer has started writing code in a certain format, do not change format in the middle of a project. Being inconsistent makes code harder to read and follow.

When commenting a program, there are many things that must be done. At the beginning of each program, there should be a block of code that describes the overall purpose of the code. Then, there should be a comment at the beginning of each function describing what the function will do. At main parts inside the function, there should also be comments describing what is occurring at those specific steps.

5. Design

5.1 Circuit Protection

An integral part of the performance of the Battle of the Bikes is the regulation of power upstream of the generator. To protect the circuitry and produce necessary voltages for the rest of the system, both passive and active regulators will be considered

5.2 Regulator Components

The following components are widely used in the majority of regulators, regardless of regulator function, and lend insight into the properties of the circuit as a whole.

5.2.1 Transistor

An integral part in many of the following regulators is the transistor. A transistor is made from a semiconductor, which is a material that exhibits electrical characteristics of neither a conductor or insulator. The pure semiconductor elements, such as Silicon and Germanium fall in Group IV of the periodic table. Compound semiconductor materials are made with Group III and V elements. These elements form covalent bonds, meaning the valence electrons are shared in a balanced bond. These atoms bond to form a crystalline structure. This structure is crucial in the manufacturing of transistors in that it allows electrons to tunnel from one bond to another and exchange places, thus allowing for diffusion.

To create a pure semiconductor that can be used in production environments, a single crystal is selected as the seed crystal. When this single crystal is dipped into its molten form, the atoms form in the same exact pattern due to the semiconductor's property of forming a crystal lattice. It is dipped and rotated until it forms a large cylindrical rod called a boule. The final diameter of the boule is controlled by the speed of rotation and that which is dipped. The standard being proposed is a diameter of 450 mm, which would decrease the cost per die from the wafer. The boule is then cut using a diamond saw into wafers.

Doping is the process of introducing impurities into the semiconductor. This is normally done at the wafer level through the process of diffusion or implantation. Diffusion can be induced with a gas, solid or liquid. In gas source diffusion, a carrier gas encapsulates the wafer where it is left of a certain period of time to achieve the desired doping characteristics. Solid source diffusion occurs when wedges of the dopant is placed between wafers and the temperature is increased to diffuse the atoms into the silicon wafer. Liquid source diffusion consists of a carrier gas being transported through the dopant liquid to then transport the dopant to the wafer. In effect, all diffusion methods involve the dopant in the gaseous state to ensure even doping in the desired area. To prevent doping in certain areas of the wafer silicon dioxide can be used as a mask because it does not allow diffusion. The other method of doping is ion implantation, in which the dopants are accelerated and radiated onto the wafer.

There are two types of doped, or extrinsic, semiconductors, with regard to those manufactured for integrated circuits (ICs). The n-type is doped with atoms that contain one extra valence electron. The p-type has one less electron, causing there to be more protons, or holes, than electrons.

The two types of transistors are field-effect transistors (FETs) and bipolar junction transistors (BJTs), which each have three layers.

5.2.2 Field-effect Transistor

FETs are unipolar in nature. This means that both terminals of the transistor are doped with either N-type carriers or P-type carriers. However, the base of the FET is comprised of the opposite dopant. The gate and source terminals control electron flow from the source to the drain with a biasing voltage. The FET is considered a voltage-controlled device for this reason. The amount a gate is biased, depending on the type of semiconductor, either increases or decreases electron or hole flow in the conduction channel. It is considered unipolar because one type of charge carrier is crossing through the conduction channel to the other terminal. Important characteristics of FETs are that they have high input impedances, which allows little current flow into the input terminal. This characteristic allows for very fast switching, making them ideal for use in electronic switches. This switching action can cause a substantial amount of power to be dissipated, decreasing the efficiency of the FET when used in this manner. Also, the power dissipation can cause transients that unintentionally switch the FET. FETs are capable of high current gains. Also, this type of transistor can regulate the output current when operated in a specific mode due to the physical limits of the conduction channel.

5.2.3 Metal-Oxide Semiconductor Field-effect Transistor

MOSFETs are a distinct type of FET that has a layer of silicon dioxide acting as an insulator between the gate and the conductive channel. This added layer acts as a capacitor. Interestingly, metal is typically not used to create the conductive upper layer of the MOSFET. A polycrystalline layer deposited on the oxide is the preferred conductor. This type of FET works by applying a large positive voltage on the gate. This attracts the electrons to this pole of the gate. The holes in the substrate are repelled from the positive voltage source, allowing electrons to travel from the source to drain. This region, or the hole inversion layer, functions as the conduction channel for the MOSFET. When a voltage needs to be applied to the gate to create the inversion layer it is called an enhancement mode MOSFET or NMOS. The necessary applied gate voltage to allow current flow is called the threshold voltage. A positive voltage can also be applied on the drive terminal to increase the drain current up to the point of saturation. The saturation point can be computed using the following equation.

$$V_{Drain-Saturation} = V_{Gate} - V_{Threshold}$$

The conductivity of the MOSFET depends on physical properties such as the thickness of the oxide layer and the permittivity. It also depends on the mobility

of the electrons in the conduction channel. The conductivity is proportional to the width of the channel and inversely proportional to the length.

One of the main benefits of the MOSFET is that ICs can be made with a relatively small number of extra components, such as resistors or diodes. In effect, it allows the circuit to be as small as possible. In addition, it is so small that the length of the induction channel is less than one micrometer. Due to the insulating oxide layer, the MOSFET has the highest input impedance of the FETs and is higher than bipolar-junction transistors.

5.2.4 Bipolar Junction Transistor

BJTs are bipolar in nature. The bipolar junction transistor is comprised of two junctions. The p-n junction is the interface between the two types of extrinsic semiconductors. When the two polarities are combined, electrons from the n-type area diffuse to the p-type and visa-versa. The electrons leave holes in the n-doped region and the holes leave electrons in the p-doped region. This in effect creates an internal electric field called the depletion region. The depletion region creates a barrier for diffusion to take place between the two poles. Current can flow between the two terminals when this region is overcome by an external electric field. BJTs are either NPN type or PNP type, comprising of two p-n junctions. The NPN means the outer sections of the BJT are heavily doped with electron carriers while the middle section is doped with hole carriers. The PNP is the opposite of this. The voltage polarities and the direction of current are opposite are also the opposite of the NPN. There are three sections associated with BJTs. The collector, base, and emitter. How the external circuitry is routed changes the configuration of the BJT, allowing it to have different characteristics under each configuration.

	Input Impedance	Output Impedance	Voltage Gain	Current Gain	Power Gain
Common Base	Low	High	High	~1	low
Common Emitter	Medium	Medium	Medium	High	Very High
Common Collector	High	Low	~1	High	Medium

Table 25. BJT Comparison

The bipolar junction transistor operates in four different modes. The first is Forward-Active. This region of operation allows the flow of current from the collector to emitter to be proportional to the base current. The Reverse active mode allows the current flow for the emitter to the collector to be proportional to the base current. The Saturation mode acts as a short circuit and current flows freely from collector to emitter. The Cut-off mode as an open circuit, not allowing current flow.

BJTs have real-world applications in switching circuits. They can be used to create logic gates, such as an AND gate and OR gate. The bipolar junction transistor can be used as an oscillator. The strength of this type of transistor lies in amplification. Based on the application of the BJT, the user can determine which type configuration to use. The transistors can be waterfalled to have a stronger combination of beneficial properties, such as high input and output impedances. The multistage amplifiers also have the benefit of increasing the overall gain of the BJT circuit to one that could not be reached on its own.

5.2.5 Diode

The basic semiconductor diode is nonlinear and uses a single p-n junction and conducts current in one direction. The principle is the input impedance in one direction is ideally zero, while in the other it is infinite. An important characteristic to note is depending on the type of semiconductor, a consistent voltage drop is seen across the diode when it is forward-biased ranging from around 0.2 to 0.7 volts.

The Zener diode differentiates itself by the use of both the reverse biased and reverse breakdown regions. A reverse biased diode has the cathode at a higher potential. In this case, this allows the Zener diode to act as a resistor for low voltages. The diode allows current to linearly increase with the voltage increase until the breakdown region is reached. A typical value for the breakdown voltage, or Zener voltage, is 5.6 volts. The Zener diode will operate reliably, unlike other types of diodes, within its breakdown region if the current is limited to the rating of the Zener diode.

Diodes can be used in rectifier circuits. In a half wave rectifier only the positive portion of an AC signal to be seen at the output of the circuit. A full wave rectifier allows the negative portion of the input to be converted to a positive signal as well. This, in conjunction with capacitors can be used to convert an AC waveform into a DC output. The Zener diode can be used as a voltage reference because its breakdown voltage is known and consistent. If the voltage drop across the diode is more than the breakdown voltage it allows current to flow. Varactor diodes are used in tuning circuits. The diode is reverse

biased and the more voltage applied to it, the larger the depletion region gets and the less capacitance the diode exhibits. Tuning in this manner is widely used in RF applications. It is important to incorporate a DC blocking capacitor in series to ensure an over-voltage situation is not induced. Diodes are widely used in over-voltage protection circuits as well in which a Zener diode is used. It is used in the same way the voltage reference circuit it used. Once the voltage applied to the anode exceeds the breakdown voltage current begins to flow to ground through it. In effect the Zener diode demands a maximum voltage output. LEDs, or light emitting diodes, operate from the principle of recombination. When a voltage differential is applied to the diode the charge carriers are able to flow. When these charge carriers reach the opposite pole many go through the process of recombination. For example, if there is an extra electron an atom that does not have a full valence shell attracts the electron. Because a free electron has more energy than one in a covalent bond, the electron exerts its extra energy in the form of a photon. In the case of an LED the amount of energy released corresponds to the wavelength of a specific color. Diodes can be used as switches as well. If it is forward biased it is on, if it is reversed biased no current flows and it is off.

5.3 DC Regulator Types

The two main branches of regulators are passive regulators and active regulators. The passive regulators are typically RLC circuits consisting of resistors, inductors and capacitors, while the active regulators typically use transistors and/or diodes. These two categories are defined based on the individual components ability or inability to amplify or regulate a signal.

5.3.1 Passive Regulators

Passive Regulators are built using components that cannot supply a sustained power greater than zero. They are only capable of down converting a voltage and typically expend the extra power as heat. Depending on the amount of power being dissipated, a heat sink should be considered to protect the surrounding circuitry or this might not be the appropriate circuit to implement. These regulators typically consist of passive elements, such as resistors and diodes. When implemented, passive regulators provide an inexpensive option to convert to a lower voltage.

5.3.1.1 Voltage Divider Circuit

The voltage divider is a linear circuit implemented by at least two resistors with the output voltage line in the middle of the two. The circuit current travels across the first resistor which creates the first voltage drop. The output voltage is the equivalent to the voltage drop from that potential to ground across the

second resistor. This functioning of this simple regulator is illustrated by the following schematic and equation.

5.3.2 Active Regulators

Active regulators are defined as regulators that contain components that amplify. In other words, an active element is one that can output an average power greater than zero. In These types of regulators typically require a negative feedback loop to stabilize the system. An example of a negative feedback loop is a portion of the output is fed back to the input. The change in the input changes the functionality of the circuit. Negative feedback loops limit the amount of gain a system can achieve; however, it decreases noise and distortion and increases bandwidth. It is important to note that active regulators regularly use passive regulation, such as the voltage divider circuit as well as the active components within the IC.

5.3.2.1 Linear Regulators

The linear regulator is used to provide a constant voltage output even when the current is variable. This is achieved by using a voltage controlled current source, such as a MOSFET. The output voltage is always lower than the input due to the turn on voltage of the various active components. Typically, this type of regulator allows for a smaller package due to additional components not being needed, which also decreases cost. They tend to be less noisy because they are not switching. The linear regulator typically has a fast response to regulate the output voltage due to only relying on the turn on time for the active components within the circuit. However, they tend to dissipate more heat to regulate the output voltage. Linear regulators, though typically designed with nonlinear components, are considered linear because they operate in the linear region those devices.

5.3.2.2 Shunt Regulator

A shunt is defined as a component that allows current to be diverted through it, creating the ability to regulate the output voltage of a circuit. The shunt regulator operates by connecting a Zener diode in parallel to a load resistance. The diode maintains a constant voltage drop across it. The drawback to this regulator comes with a varying voltage source. The shunt regulator is designed around the nonlinear characteristics of the Zener diode. This type of regulator is often inefficient because excess current flows directly to ground.

The below is an example of a simple shunt regulator circuit and the accompanying equation used to calculate the ideal resistance for R1.

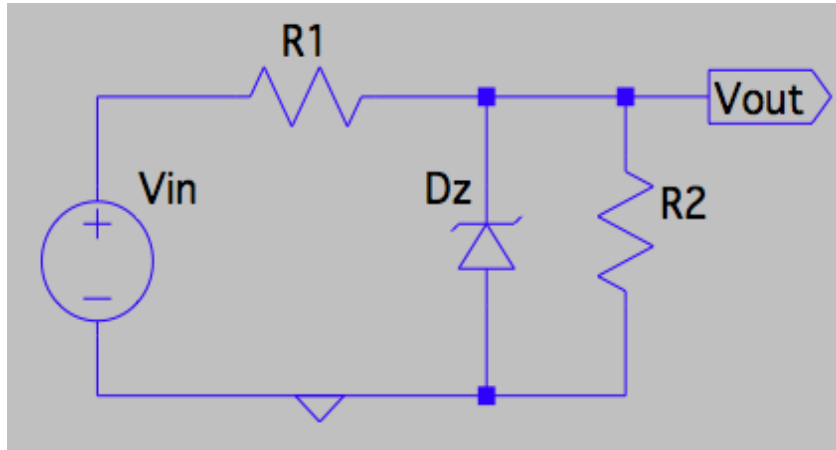

Figure 17. Shunt Regulator Circuit

$$R_1 = \frac{V_{in} - V_Z}{I_Z + I_{R2}}$$

5.3.2.3 Transistor Regulator

The simple transistor regulator consists resistors, a Zener diode and a N-P-N bipolar junction transistor (BJT). The transistor is typically found in the common collector configuration. The reference voltage is provided by the Zener diode at the base of the N-P-N BJT. The BJT is controlled by the base current, which allows it to operate as a variable resistor. As the current increases, the resistance of the N-P-N junctions increases, causing more voltage to be dropped across the transistor and the output voltage to remain relatively constant. The below is an example of a simple transistor regulator circuit and the accompanying equation used to calculate the output voltage.

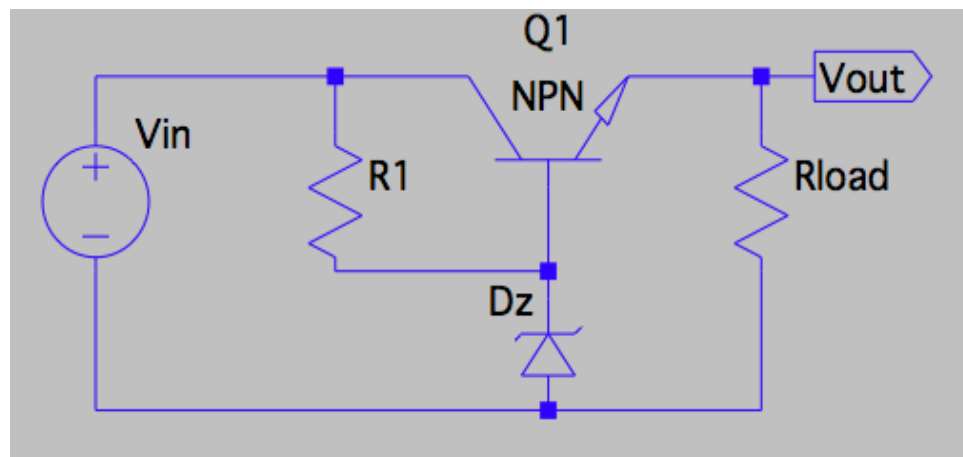

Figure 18. Transistor Regulator Circuit

$$V_{out} = V_Z - V_{BE}$$

Where V_{BE} is the voltage drop from the base to emitter terminals. R_1 creates the bias current for the Zener diode as well as the transistor. As the value of R_1 increases more input voltage is needed, decreasing efficiency. A value too low can cause the reverse biased Zener to operate in its breakdown region.

5.3.2.4 Operational Amplifier Regulator

The typical op-amp circuit typically has 20 to 30 transistors. Using the beneficial characteristics of multiple transistor circuits parameters close to ideal can be defined. The operational amplifier has differential inputs consisting of a noninverting terminal and inverting terminal. These terminals have an infinite resistance between them, which means that no current flows into the terminals. Ideally, the open-loop gain of the op-amp approaches infinity and the output resistance is zero. The operational amplifier is typically biased with both positive and negative voltage sources. The op-amp is biased to allow for the largest range in gain and to ensure the signal is transferred in its entirety to the subsequent components. The typical operational amplifier regulator also incorporates a Zener diode as a voltage reference for the output of the circuit as well as a transistor. The transistor is in the common collector configuration and acts as a current supply. The below is an example of a simple operational amplifier regulator circuit.

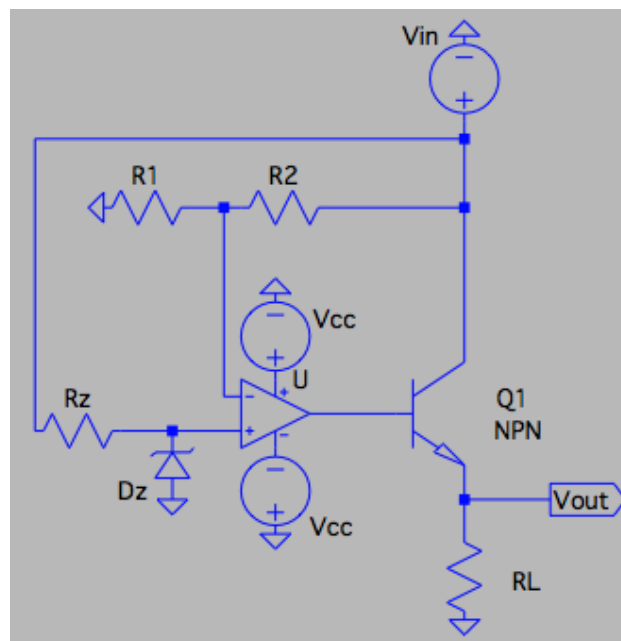

Figure 19. Op-Amp Regulator

The output voltage is controlled by the resistances selected for R_1 and R_2 .

5.3.2.5 Low Dropout Regulator

The LDO allows for the regulator to operate closer to the input voltage and therefore be more efficient. A power FET is typically used in conjunction with a differential amplifier. The differential amplifier works by having voltage sources on both the inverted and non-inverted inputs. One of the inputs has a feedback loop from the output voltage. If this voltage is too high relative to the input voltage, the input to the FET decreases to keep the output voltage constant. LDOs are capable of achieving higher efficiency due to implementing an open drain connection. Less power is used because signals are kept floating. Low Dropout Linear Regulators are best used when there is a small differential between the output and input voltages. The LDO operates by monitoring the output voltage and adjusting the current source to regulate the output voltage. The LDO has the highest ground pin current of all of the linear regulators. The ground pin current can be calculated by following equation.

$$\text{Ground Pin Current} = \frac{I_{LOAD}}{\text{Gain of the PNP transistor}}$$

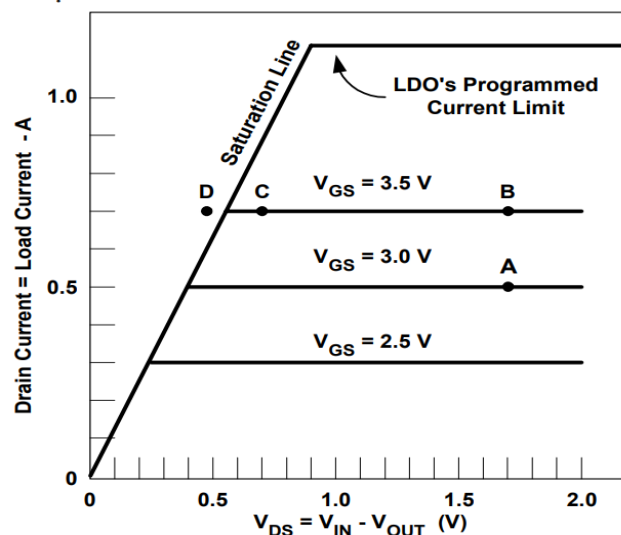

Figure 20. LDO Drain Current vs Voltage

The monitoring circuitry used is a feedback loop with compensation to aid in stability. The LDO requires an external capacitor connected to ground for stability. Due to the nature of feedback loops, there is an inherent lag in timing from sensing the over voltage situation to correcting it. This lag, called the transient response, is a measure of how quickly the regulator returns to steady-state conditions. A differential op-amp circuit is typically used to sense the difference between the reference voltage and the output voltage. The following is an example of the linear regulator implementing a Darlington pair of BJTs driven by a PNP transistor to amplify current with a differential op-amp.

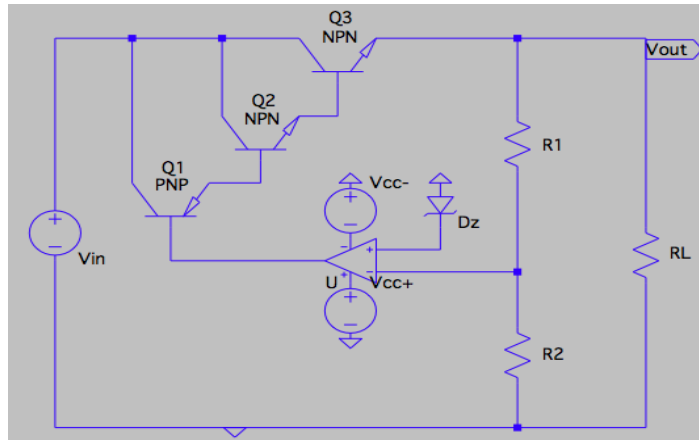

Figure 21. LDO Circuit

The output voltage is a multiple of the Zener diode reference voltage that is dictated by the values of R1 and R2. In the above configuration, the minimum voltage drop is the drop across the PNP transistor. The Low-dropout regulator is widely used in applications with small voltage sources, such as battery powered products.

5.4.3 Switching Regulators

Switching Regulators operate by switching the internal components, such as FETs on an off. The duty cycle of the regulator is determined by this action. A duty cycle is defined in the following equation.

$$Duty\ Cycle = \frac{Pulse\ Width}{Period} * 100$$

The larger the duty cycle, the more current propagates to the remaining circuitry. The duty cycle of the regulator is created by pulse width modulation (PWM). The switching regulator has a similar feedback loop as the linear regulator; however, the feedback is fed back to the switch. If the output is too high, the switch is turned on for less time, decreasing the pulse width. After the switching action, there is an inductor acting as an energy storage device. The inductor allows current to flow freely across but will only allow for the magnitude of the voltage to change with a changing current. The faster rate of change of the current through the inductor, the larger the output voltage. Below is the schematic for a typical pulse width modulator.

Generally, compared to linear regulators, switching regulators are much more efficient but also more complex. They have the ability to be smaller than linear regulators depending on the frequency. The device gets smaller the higher the

switching frequency is. The switching regulator allows for a wider input voltage range due to the pulse width modulation dictating the output voltage. Due to the complexity, the switching regulator tends to be more expensive. They also tend to be more noisy as a result of the switching action.

5.4.3.1 Buck Regulator

The Buck regulator is used in DC-DC regulation to down-convert a voltage. The output has the same polarity as the input voltage. The following schematic illustrates the Buck regulator.

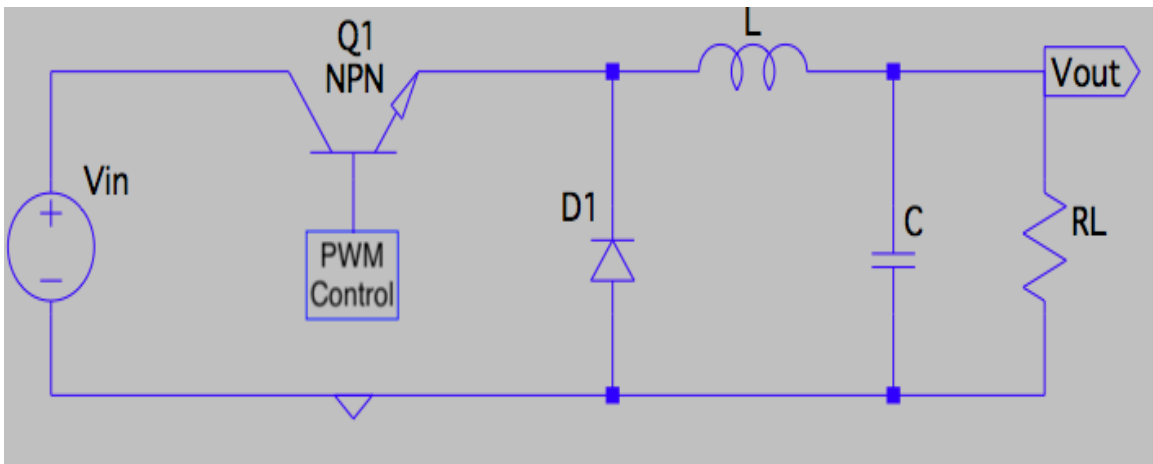

Figure 22. Buck Regulator Circuit

When the transistor allows current flow, the switch is on. In this case, the input voltage can be seen at the first terminal of the inductor minus the voltage drop across the transistor. This voltage differs from the output voltage. Due to the difference, the current through the inductor increases. During this on time, the current is allowed to flow through both the path of the capacitor as well as the load resistor. The current charges the capacitor.

When the switch is off there is no voltage differential over the inductor so current does not flow. However, because of the properties of the inductor, current cannot instantaneously change and the inductor maintains a constant current. The input of the inductor eventually is forced low due to the lack of current. This differential allows the diode to activate and allows current to flow through the inductor loop. At the same time, the capacitor begins to discharge creating another current loop. The sum of the current through the inductor and the current through the capacitor is the current through the load resistor and drive the output voltage.

The load current is the average value of the current through the inductor. Most regulators are made to always be in continuous mode, meaning the inductor

current never drops to zero. Due to the action of charging and discharging the inductor has a ripple current. The inductor ripple current is defined as the difference in peak-to-peak voltage of the output current. This is generally kept under 30% of the output current. When there is a smaller load current the regulator can operate in discontinuous mode. The discontinuous mode allows for a smaller inductor to be used and a smaller footprint for the converter.

5.4.3.2 Boost Regulator

The Boost regulator produces a DC-DC conversion that creates a higher output voltage than the input voltage. Both the input and output voltages have the same polarity. The following schematic illustrates the Boost regulator.

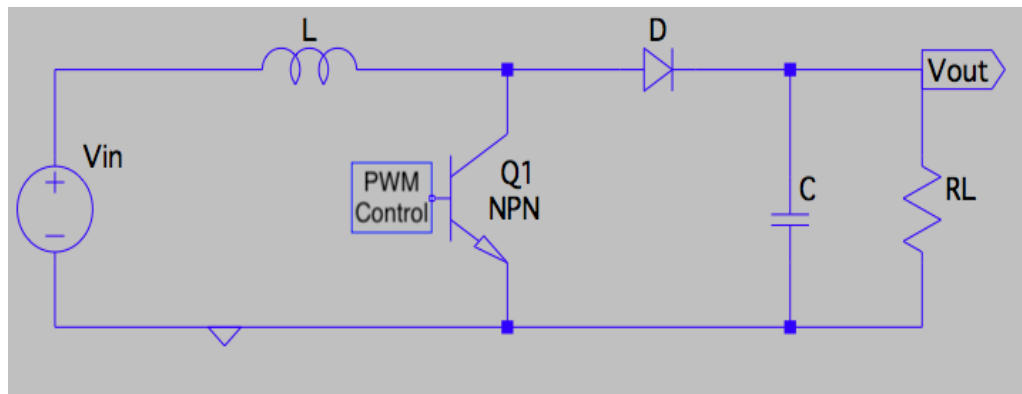

Figure 23. Boost Regulator Circuit

Voltage is forced across the inductor when the transistor is active. This action causes the current to ramp up. When the switch is turned off the current through the inductor decreases and forward biases the diode. The diode allows current to flow through the load path and capacitor, charging the capacitor to a higher voltage than the input voltage. During the off time of the transistor the current to the load is supplied by both the inductor and the capacitor. However, during the on time, the current is supplied by only the capacitor due to the diode not being forward biased. The output current and current through the transistor are not always equal and the maximum output power is always equal to or less than the input power. Therefore, to have a larger output voltage than input the output current must be less than the input current.

$$Power = Voltage * Current$$

5.4.3.3 Buck-Boost Regulator

The Buck-Boost regulator has the ability to produce a DC output voltage that is either larger in magnitude or smaller in magnitude than the input voltage. This regulator differs from the previous two in that the output polarity is the opposite of the input voltage, so if the input voltage is positive the output will be negative. The following schematic illustrates the Buck-Boost regulator.

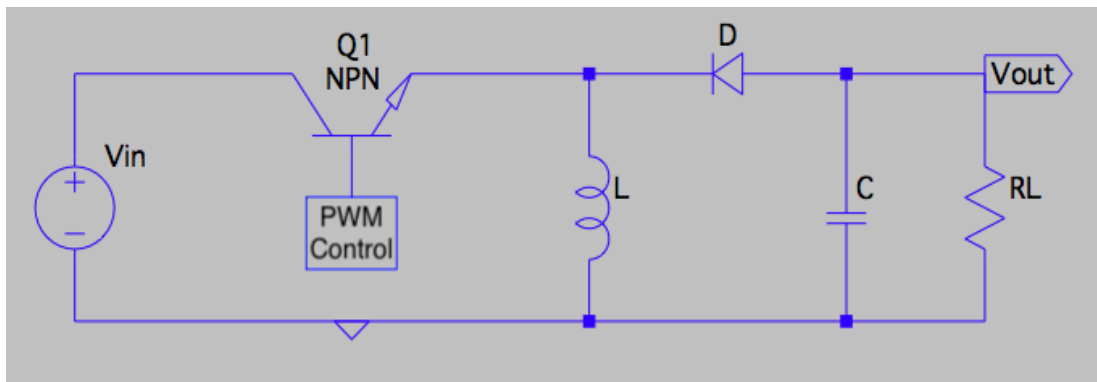

Figure 24. Buck-Boost Regulator Circuit

When the switch is on the voltage is forced across the inductor, ramping up current flow. When the transistor is off, the inductor forward biases the diode and creates a current loop which allows the capacitor to charge as well as creates the output current across the load resistor. When the switch is then turned on again, the capacitor discharges and creates the output current for the load resistor.

The Buck-Boost regulator can have an inverting operational amplifier, such as the one below, if the output voltage is needed to be the same polarity as the input voltage. The following schematic illustrates a typical inverting op amp current.

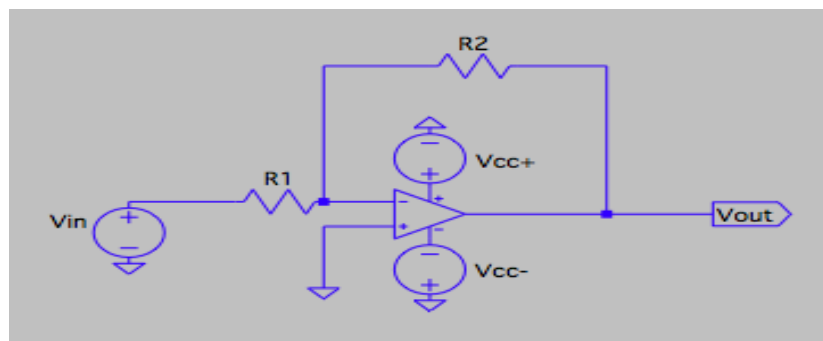

Figure 25. Op-Amp Buck-Boost Circuit

Adjusting the values of R1 and R2 allows for another gain stage to be added to the regulator. If R1 and R2 are equal the output of the op-amp will have a gain

of -1, where the output voltage will be of the same magnitude of the input voltage of the opposite polarity. The gain of the typical inverting amplifier follows.

$$\frac{V_{out}}{V_{in}} = \frac{-R2}{R1}$$

5.4.3.4 Flyback Regulator

The Flyback regulator differs from other regulators in its versatility. The regulator is capable of creating one or more voltages that are both negative and positive. This capability allows this one regulator to have the potential to create the voltages for an entire system instead of taking up valuable board space populating multiple regulators. The following schematic shows the topology for a single output Flyback regulator.

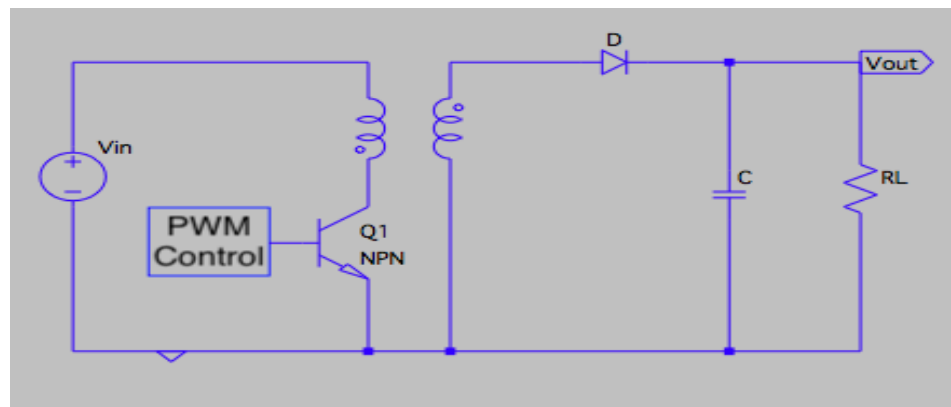

Figure 26. Flyback Regulator Circuit

When the transistor is on, or the transistor is allowing current to flow, the input voltage is forced across the primary winding of the transformer. This changing voltage causes an increase in current. The voltage drop over the first winding goes from the upper portion toward the transistor. A voltage of the same polarity is induced on the second winding.

A transformer works by the conservation of energy, meaning the power on the secondary winding must be equal or less than the power on the first winding. It is always slightly less in a real-world application due to in-system losses, such as impedance losses in the wire. The transformer can increase or decrease the voltage on the output of the regulator, and this is dictated by the amount of windings the second transformer has compared to the first. When there are more windings there is an increase in voltage, but also a decrease in current.

When the switch is on the induced it turns off the diode, disallowing the current to reach the load resistor. In this mode, the capacitor discharging is what allows there to be a constant voltage at the output. When the switch is off, the decrease in current causes the secondary winding to be positive. This turns on the diode and allows the capacitor to charge as well as supplies the output resistor with the necessary current to create the constant output voltage. Like the buck converter the Flyback regulator can be operated in the continuous or discontinuous mode.

The Flyback Converter can also be used to provide multiple voltage outputs. To achieve this, one of the outputs is feedback to the pulse width modulator. Though this feedback causes a delay, it allows the output to be directly regulated. This causes the secondary outputs to be regulated as well since they are tied to the same pulse width modulator. Therefore, their duty cycle will follow the same pulse width as the primary output.

5.3.4 Push-Pull Converter

The Push-Pull converter can be used in DC to DC conversion as well. There are two transistors that are alternately powered on, so during one on cycle for the first the second is off and so on. The secondary winding of the transformer has current flowing at the same time as the primary winding regardless which transistor is turned on.

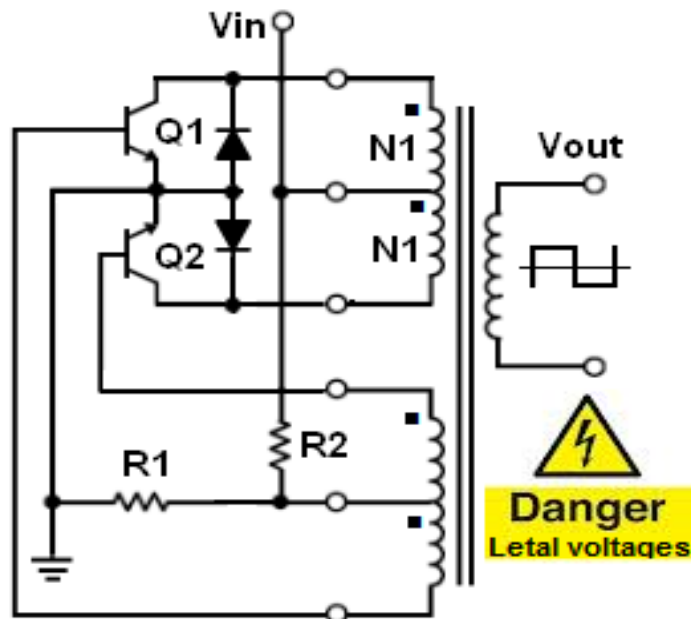

Figure 27. Push-Pull Converter Circuit.

The Previous circuit diagram displays a Push-Pull converter circuit.

5.4 Input Power Conversion

If an averagely fit person were to pedal a bicycle for an at a consistent pace, this would be enough energy to power a digital alarm clock for 10 hours, and could expect them to produce about 100 watts of continuous power. To put that in perspective a standard laptop for 2 hours, or a 19 in LCD screen for 1 hour 40 min. For a standard Arduino microcontroller, the operating power requirements are 7-12V DC input voltage (with a max input of 20 V), and between 0.5 to 1 Ampere of current. For the Battle of the Bikes we do not want to limit the device charger to just phones, so while a typical smart phone will charge at 5V and around 1 A, a tablet device such as an iPad needs 5 V at 2.1 A. If a larger device is considered for charging like a laptop the Battle of the Bikes would need to output potentially up to 5 A of current. The Battle of the Bikes is going to need to power several internal components as well as a few external. These include the microcontroller, the wireless transmitter/receiver, the screen of the user interface, and the added device charger. Both AC and DC current is needed for all of the features of the Battle of the Bikes. DC will be most commonly used for all of the components, but an AC signal is required for the device charger. Since the electrical energy generated will be from the DC generator, for the device charger a DC/AC converter must be used.

There are two ways of accomplishing this. One way is to convert the low voltage DC into AC; the problem with this method however, is that the AC generated will not be strong enough to power most devices since in the US a 120 V rms 60 Hz AC signal is needed. To achieve this, a step-up transformer would need to be added to increase the AC signal to the proper voltage. The other method for DC/AC conversion would be to first amplify the DC voltage and convert that high voltage to the correct AC signal strength immediately. In order to reduce the need of a transformer the latter method will be used. To convert the high voltage DC into an AC signal a technique known as Pulse Width Modulation (PWM) is used.

A typical AC signal you will find in your home outlets will be a in the form of a sine wave. Since DC signals are a constant value the conversion to AC can either generate what is known as a modified sine wave or a pure sine wave. A modified sine wave is essentially also a modified square wave. By splitting the square wave into steps, it can imitate the average RMS values of a sine wave. This method is much easier to achieve than the pure sine wave inversion as you can imagine and also provides a much cheaper and simpler option when it comes to implementation.

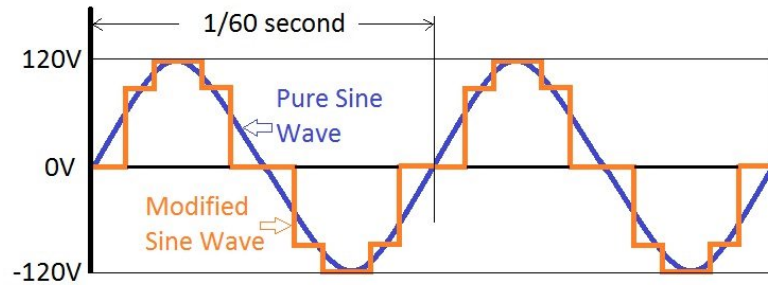

Figure 28. Pulse Width Modulation vs Pure Sine Wave

From Figure 28 you can see the difference between the modified sine wave and the pure sine wave. The modified sine wave however can cause issues and even damage equipment designed for pure sine waves such as laptops. This eliminates it from consideration for the Battle of the Bikes. That leaves a pure sine wave inverter. The complexity and cost of the pure sine wave far exceed that of a modified due to the extra circuitry required, however it is much more versatile and safer for charging any electronic as it perfectly mimics the power received through home outlets. By adjusting the duty cycle of the modulated pulse width signal the receiver or output of the circuit resembles a sine wave.

5.5 Pulse Width Modulator

PWM is the most commonly used method for converting DC to AC. PWM essentially manipulates the constant DC signal by allowing it through a circuit in pulses at different duty cycles and at either positive or negative values causing the output to perform similar, but not exactly, like an alternating analog signal. The following image displays how a PWM's output looks like at various duty cycles.

5.5.1 Bubba Oscillator

One such way to generate a sine wave is with a Bubba Oscillator. By combining four operational amplifiers in series that each shift the signal by 45 degrees to generate a 180-degree phase shift of the original signal. While the Bubba oscillator is not the only oscillator circuit that can generate a sine wave, it is widely used to do so for its low total harmonic distortion. THD is the measure of the distortion created by operational amplifiers due to the harmonics of the waveform. Another advantage is the Bubba oscillator allows you to generate any frequency of signal desired by manipulating the resistors and capacitors of the circuitry.

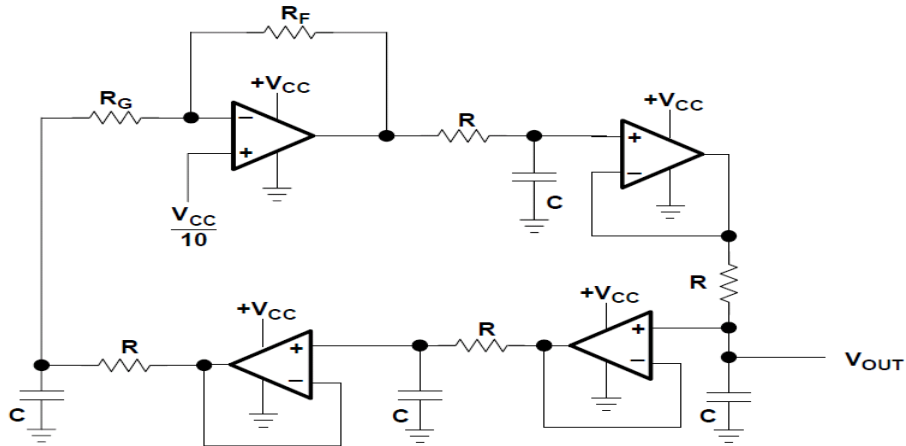

Figure 29. Bubba Oscillator Circuit Schematic

By selecting a fixed value for the capacitor, you can use the following formula to determine the resistor values for the circuit.

$$\omega = \frac{1}{RC} \Rightarrow R = \frac{1}{2\pi f C}; \omega = 2\pi f$$

Since a frequency of 60 Hz is what we need for the Battle of the Bikes, we plug that into the formula, with the chosen value of $C = 1 \mu\text{F}$ to obtain the resistor value.

$$R = \frac{1}{2\pi * 60 * 1 * 10^{-6}} \Rightarrow R \approx 16.5 \text{ k}\Omega$$

Due to unavoidable attenuation of the signal through the operational amplifiers, the signal loses a lot of strength, specifically the output signal will be $\frac{1}{4}$ of the amplitude of the input. This is fixed with R_f and R_G from Figure 29. The gain must be exactly 4 to fix this and the ratio of $\frac{R_F}{R_G} = 4$ is required. The values chosen for R_F and R_G can be anything as long as the previous ratio of 4 is preserved, however it is better to use larger resistor values as the oscillation for the circuit is created via the noise from these resistors. For this reason, values of $R_F = 1.4 \text{ M}\Omega$ and $R_G = 350 \text{ k}\Omega$ have been selected. With these selected resistor and capacitance values chosen a 60 Hz sine wave can be generated.

5.5.2 AC/DC Converter

Some features of the Battle of the Bikes require AC power as well as DC. It is not uncommon for an electronics system to implement both converters and inverters. For example a typical laptop computer; a laptop will draw power from

an AC power outlet in a home or office, that power then runs through an AC adapter to convert the AC signal to DC to power the laptop and charge the battery. Within many laptops is an inverter for the screen that then inverts the DC power back to AC in order to power the LCD or LED screen. Similarly the Battle of the Bikes will require both AC and DC power. A converter takes the alternating current and separates the reactive power from the impedance elements. This also isolates the positive and negative voltages that then run through filters in order to generate a DC voltage to be supplied to the remainder of the circuit. One of the more common modes of conversion is using a transformer to pass AC current to a rectifier that then produces DC current. While this may be a simple process to convert AC to DC, it can often be a noisy system. The following circuit displays a more complicated AC to DC converter circuit known as a forward Converter.

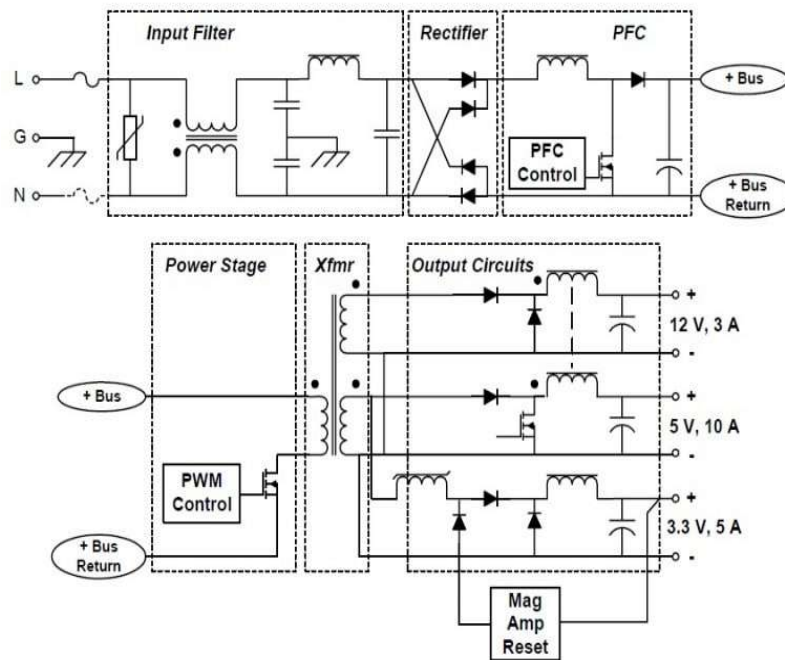

Figure 30. Forward Converter Circuit Diagram.

The Forward converter is a more complex circuit for AC to DC conversion, but it is very efficient with minimal power loss through the system.

If a simpler design is to be considered then a flyback converter is a logical choice. The flyback converter has less components and is thusly a cheaper more cost effective circuit. The drawback is the power efficiency is not as good as the forward design. The Flyback converter diagram is as follows.

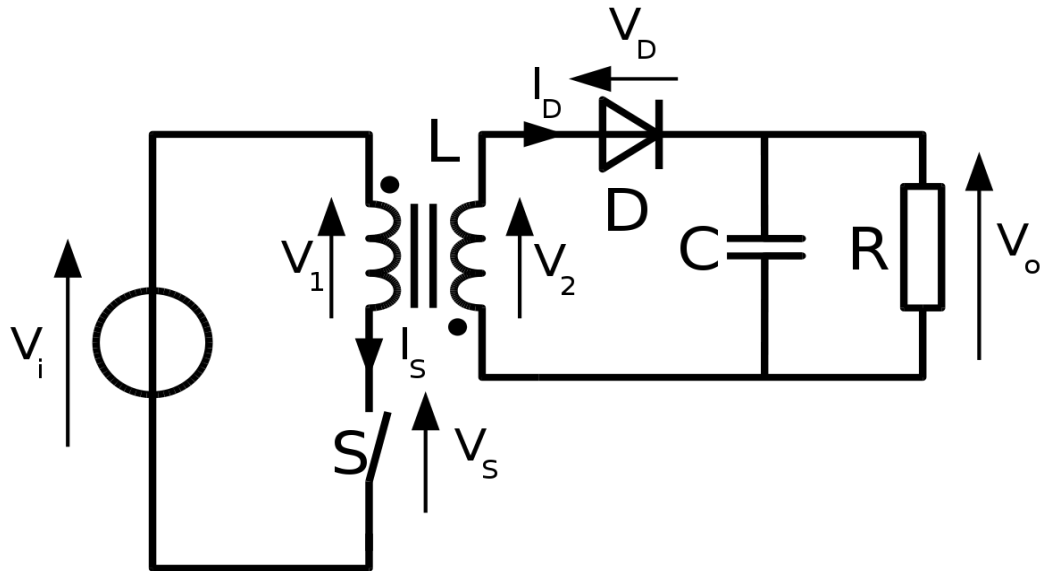

Figure 31. Flyback Converter Circuit Schematic.

Another common method of AC to DC conversion is via a Bridge Wave rectifier. A Bridge rectifier uses pairs of Diodes in parallel to take alternating voltage from AC and rectify it into always positive values and then takes the average values and produces a DC current. The circuit diagram for a Bridge Rectifier is as follows

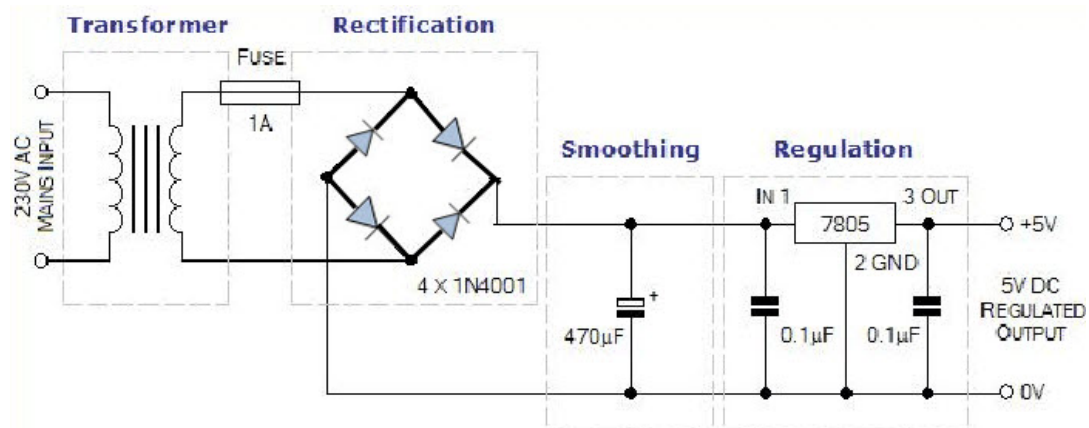

Figure 32. Bridge Rectifier AC/DC converter circuit.

With any AC to DC converter type an important aspect of the circuit is the input filter. The input filter helps manage and deter noise from the power supply. It also helps prevent noise from seeping into the rest of the system. The following displays a sine wave that has been rectified in conjunction with a capacitor to show how they can start to form a constant voltage from the original alternating signal. A full wave rectifier will be even smoother and more accurate to a constant value.

For the purposes of the Battle of the Bikes a Flyback Converter is the most plausible choice. It is not as efficient as the forward converter, but does provide a more cost-effective option with sufficient or at least acceptable power loss.

5.6 Battery Management System

One very important component of the Battle of the Bikes is the power storage device. The main purpose of the Battle of the Bikes is to convert the energy generated by the user via the rotary system to usable power for the entire system as well as charge external devices such as a smart device. Since there will be multiple other components that need to be powered it is ideal to have the converted electrical energy stored first before distribution. A Battery Management System (BMS) is the best way to deal with any excess energy generated while simultaneously supplying the system with enough constant power to maintain function. A BMS is common in most electronic devices today. The increased reliance on electrical technology in today's world has led to significant advancements in power and battery management within a system. BMS's are made up of several main components that include: voltage monitors (overall and individual cells), real time clock, temperature controls, state machine, and usually MOSFET ICs for protection. There are two types of architecture when designing a BMS, centralized and modular. In a centralized architecture, components can be isolated and removed for repair if damaged easily, making the most cost-effective architecture; however, the connection to each cell uses long wires. A modular architecture uses shorter wires reducing the distance to each cell, but it is less cost effective than centralized because when a component fails you must replace the entire module. Keeping in mind that the Battle of the Bikes is going to deal almost entirely with low voltages, the centralized architecture is ideal for the design.

Along with the charging and discharging of the battery a BMS will also manage a protection circuit. The protection circuit will disconnect the battery from the system if a failure or an excessive amount of power is detected.

Since the ultimately the Battle of the Bikes is a game in which the user uses the energy generated as an in-game weapon, the BMS's voltage monitors and fuel gauges will be monitored and displayed to the user. The microcontroller will send the data obtained from the BMS and output the gauge to the user via the interface. The following diagram is a simplified circuit diagram Battery Management systems main function building blocks.

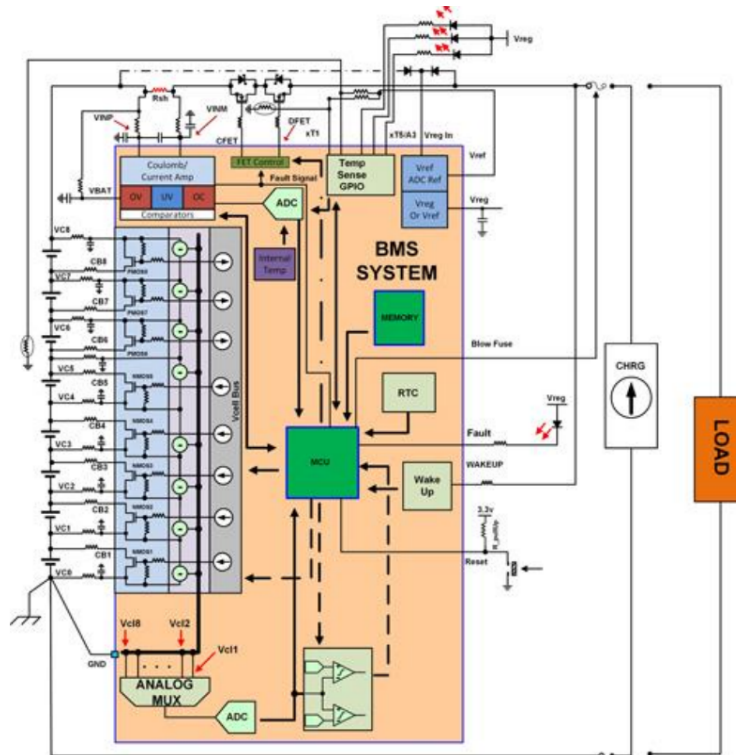

Figure 33. BMS Circuit Diagram.

5.6.1 Battery Charging

Delivering power to our battery is one of the first challenges that we must overcome in order to be able to put the entire system together. In order to charge the battery, efficiently, it is important to have a constant voltage going into it. Our rechargeable lead-acid battery is a 12V battery, and is rated between 14.5 to 14.9V for cyclic use. Therefore, in order to charge it fully we must provide it with at least 14.5V from our battery charging circuit. We have two options when it comes to inputting power into our battery, and they are using a battery charger or designing and building our own circuit to fit our own parameters.

Our bicycles will be generating about 66 watts of power each and then sending them to our battery charger, and then to the battery. When searching for battery chargers, the most important part was to get one that is capable of handling all of the current that will be coming through the system, or about 6 amperes at peak load. However, battery chargers tend to be expensive when they need to handle more than a couple of amps, and also include unnecessary features that we do not want. So, we moved to designing our own battery charging circuit.

5.6.1.1 Battery Charging Circuit

Our task then became to design and build a circuit which could charge our battery and handle all of the current that would be coming through it. In order to regulate the power generated by the motors into our battery, we require a circuit which can regulate the power delivered into the battery to be at an ideal constant voltage of 14.5V. This will serve as both a buffer in order to charge the battery at 14.5 volts as well as circuit protection for the battery to prevent any damage from occurring to it.

Lead-acid batteries charge at any voltage above 2.15V per cell, and are typically charged at up to 2.35V per cell. Since we have a 6-cell battery, anything above 12.9V and up to 14.1V will result in charging of the battery. However, the charging reaction inside of the battery takes precedence over over-charge reactions that lead to gassing, which allows the battery to be charged at higher voltages the less full it is. The ideal output voltage of this circuit when the battery is at room temperature (25C) is then between 14.4 to 15.0 volts. However, lead-acid batteries begin gassing at 14.34V at 25C and at 13.8V at 50C. The efficiency of lead-acid batteries is about 90% when half full, dropping to 60% when above 80% capacity. Using these values, the battery can be expected to dissipate between 6.9 and 27.6 watts of power due to inefficiency, a lot of which will be lost to heat.

Since this charging circuit will not be sensitive to the battery's voltage, and since we will be putting a large amount of current into the battery, it will be important to minimize the overall power coming into the battery so that it does not overheat and thus begin gassing. We will then use a charging voltage of 13.8V since it is impossible to generate any oxygen at this voltage, and this will minimize any risks of gassing in the battery and so that we can leave our charging circuit relatively simple instead of requiring a more complex voltage-sensing circuit. In order to do this, we will design a DC-DC regulating circuit that can be used for either generator. The following circuit in Figure 34 is the simplest way that a voltage regulator can be used in order to charge a battery. As the voltage of the battery increases and approaches that of the regulator, the current applied becomes smaller and smaller until it becomes a minimum when the potential difference is zero.

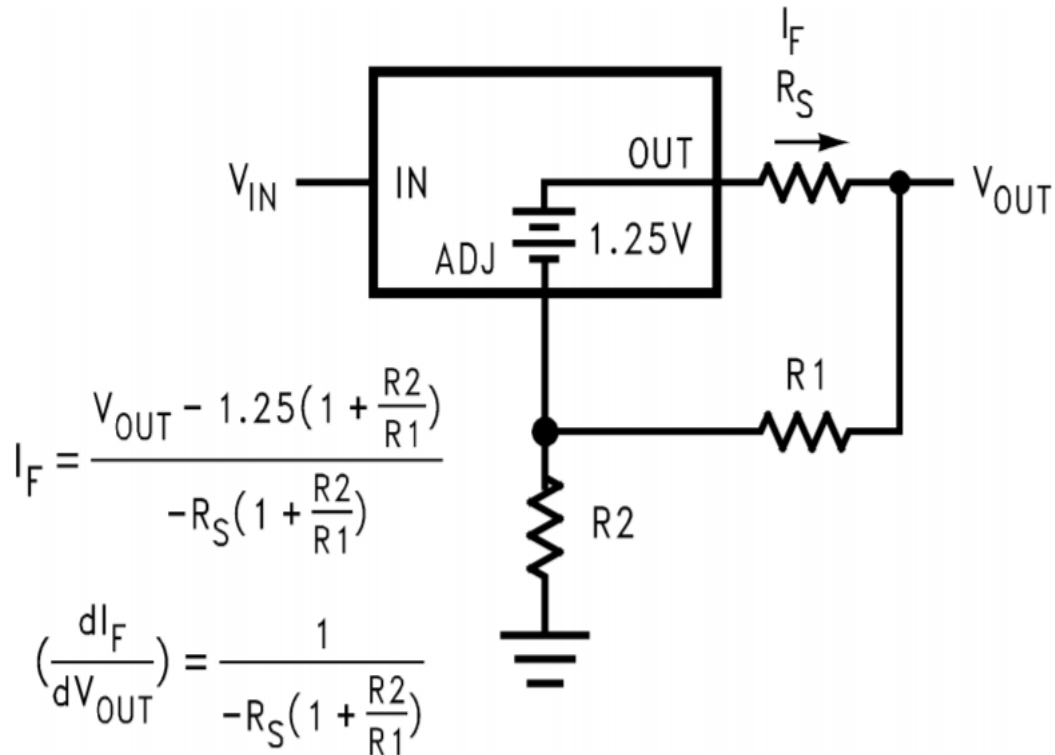

Figure 34. Voltage Regulator Battery Sense Circuit

In this battery charging circuit the energy created by each generator from either bicycle will be individually regulated and then sent to the battery. Before the power can be regulated however, we must ensure that the power going into the circuit is not too large, which would cause thermal problems within the circuit since we will be regulating up to 24V down to 13.8V at a peak desired current of 5 amperes in order to minimize risk to the battery. This means that the regulator will have about 51W of power passing through it. In order to deal with this large amount of power, we may use several voltage regulators in series in order to lower the overall thermal load on each circuit component.

The first component of these regulating circuits will be a rectifier. This rectifier will ensure that the power going into the circuit is pulsing DC and will also assure that it is of the right polarity.

Next, a capacitor is placed in parallel with a linear voltage regulator. The capacitor is used to remove any ripples or noise that may be present in the line. The linear voltage regulator simply takes whatever voltage is input and outputs the voltage it is designed to. For this circuit, the linear voltage regulator must be able to handle at most 5 amperes of current, and will be required to withstand at least 8 amperes due to surges that may occur when both players are going as fast as possible.

Next comes two resistors in parallel with each other and a diode. The diode serves to only allow current to go into the battery, not out of it when the users stop or slow their pedaling, and is the main circuit protection component. The resistors serve as voltage divider components which keep the BJT from turning on as well as powering the charging indicator, which is an LED for now.

The zener diode is used to keep track of the battery's charge level and will break down once the battery is sufficiently charged. This will then cause all of the current to flow into the BJT, grounding the linear voltage regulator and stopping all input to the battery until the voltage level once again drops to a wanted value. This then will toggle on the indicator for a full battery, which is again an LED in the circuit above.

5.6.1.2 Charging from Outlets

Since there are many different components that will drain power from our system, including an accessory charger and many different electronic devices, we will add an option to charge our system from an outlet to get the game up and running. This secondary option will simply hook into the existing charging circuit of the battery and supply it with power when it is used. The power from the outlet will be transformed down to 24 volts since that is the same voltage that the generating motor is rated for.



Figure 35. Diagram of AC portion of battery charger

5.6.1.3 Maximum Battery Current

When charging the lead-acid battery, we must not exceed a quarter of its capacity in charging current. Since we purchased a 20 amp-hour battery, the maximum current that will be allowed into the battery should be no more than 5 amperes. It is also important to be mindful of all of the components of this circuit and how much current each of them can handle. For instance, some diodes or resistors in the circuit may not be able to handle 5 amperes through them, so it will be important to pay attention to the power ratings when picking and purchasing these smaller components.

5.7 Output Power Conversion

5.7.1 Power Requirements

Our Battle of the Bikes project will be entirely limited by the total amount of power that we can generate from both bicycles. Since we have two bicycles, we will be much less worried about draining the entire power from our system simply from our electrical components. However, we must still be mindful of how much power everything will use and how this will impact the overall system. Table 26 is our estimated power budget for this project.

Component	Where Used	Power Consumption
Motors	Energy Generation	-132W
Servos	Bicycle Resistance	21W
Wireless Communications	Game	0.05 to 1W
Microcontroller	Controller	0.5W
Touchscreens	Controller	1mW
Speed Sensors	Wheel	0.2W

Table 26. Power Estimation by System

5.7.2 DC-AC Inverter

One of the goals of Battle of the Bikes is to make the power generated by the users available for external use as well. To do this, we will include a power line from the battery that runs on 120V 60Hz AC voltage. This will allow the users to charge any devices that they may have with them with the energy that they generate and will also allow for the system to power anything in the immediate area around it. We do not expect any heavy use from the inverter, with a typical use case including a combination of one or two 5-10 watt adapters to charge cellular devices and one or two 50-100 watt adapters used to charge laptops or other devices. This puts our maximum expected power output at 200 watts.

Inverters use the principle of Faraday's law in order to spin a magnet in an electric field to generate electricity. One way that inverters can be built is by

placing two coils of wire around a common iron core and a device, such as a motor, is used to continuously switch the direction of the incoming current in the first coil, which then generates an alternating current at the second coil at the frequency that the power is being switched. Another way that inverters can be built is with a moving spring with contacts, which is pulled by electromagnets, in an electric field. The direction of the pull can be reversed by reversing the current in the electromagnet, therefore allowing for an alternating current to be produced by the spring.

There are two types of inverters: true sine wave inverters and modified sine wave inverters. Modified inverters produce waveforms that appear square-like and imitate the RMS value of a true sine wave. Meanwhile, true inverters create power that resembles smooth sine waves.

5.7.3 DC-DC

On average, a typical biker can generate 100 Watts of power in one hour of riding. During short bursts, it is possible to generate upwards of 400 Watts when pedaling as fast as the user can. So, to not waste the energy that the user is putting into the system, we would want a DC converter with a max power output of at least 400 Watts. The specifications that we are putting in place are to keep our losses at a minimum and allow our system to be as efficient as possible.

5.8 Low Dropout Regulator Circuits

A low dropout regulator (LDO) is a type of linear voltage regulation circuit designed to decrease the output voltage by a very small margin from the input voltage. For instance, a common voltage regulator such as a 7508, has a minimum dropout voltage of 2V from the input. This kind of dropout is too large for the Battle of the Bikes, thus a more sensitive LDO must be used. In the design of the Battle of the Bikes's transceiver there are several components that require close to, but not quite equal voltages for operation. Multiple LDOs will be implemented throughout the transceivers circuitry to regulate the voltages.

Figure 36 is that of a standard LDO voltage regulator circuit schematic.

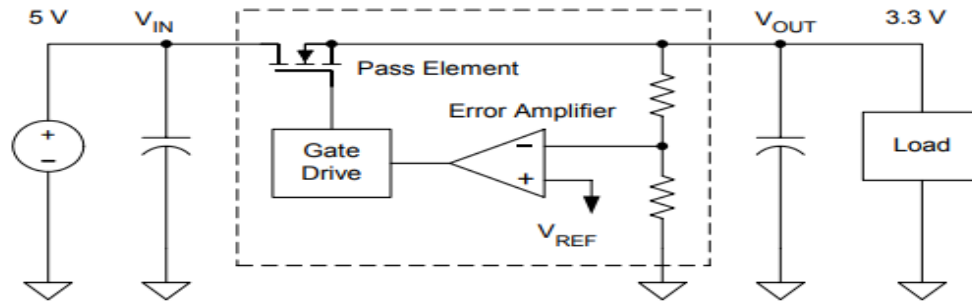

Figure 36. LDO Voltage Regulator Schematic.

LDO circuits are similar to any linear voltage regulator circuit with the exception of the collector scheme. While a typical voltage regulator such as the 7508 use a common collector schematic, the LDO uses an open collector. In the open collector scheme, the collector node of the transistor is left open and attached to part the of integrated circuit instead of being directly supplied with a voltage like the common collector.

Throughout the transceiver there will be several stages of voltage dropout as well as an instance of voltage inversion. Starting from the 5V needed for the up converter, which can be regulated down from the 12V battery via a standard voltage regulator of the 7508. After that the PLL, DA, Digital Signal Processor, and DAC converter all require only 3.3V, this is where the first LDO will be installed. An LM3940 from Texas Instruments is designed to regulate 5V input to 3.3V output and is ideal for this application. The circuit diagram is as follows:

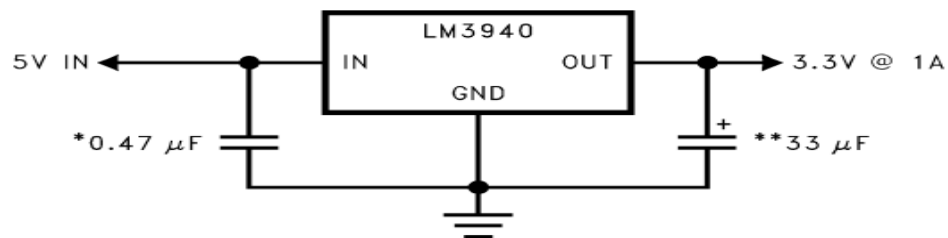

Figure 37. LM3940 5V to 3.3V LDO

The capacitance values shown in Figure 37 are for the minimum allowed and can be increased without limit for better transient response. Following the 3.3V dropout the low pass filter required for the design will need to reduce the 3.3V to 2.5V, as well as add an inverted -2.5V input. The LT1965 is an LDO regulator specifically designed for dropping 3.3V to 2.5V. The output amps directly correlate to the amount of voltage drop off as follows.

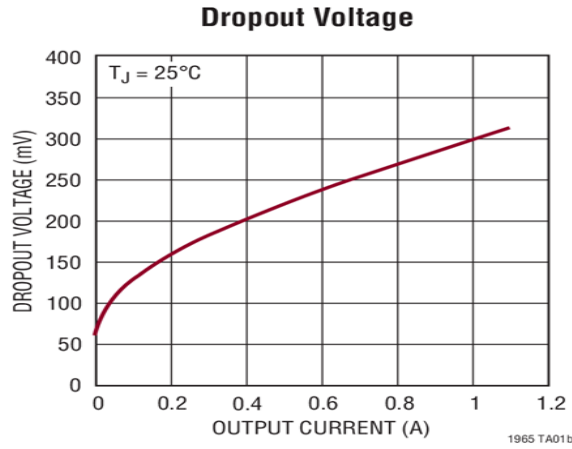

Figure 38. Current vs Dropout Voltage LDO.

The following circuit diagram displays the 3.3V to 2.5V LDO regulator circuit using an LT1965.

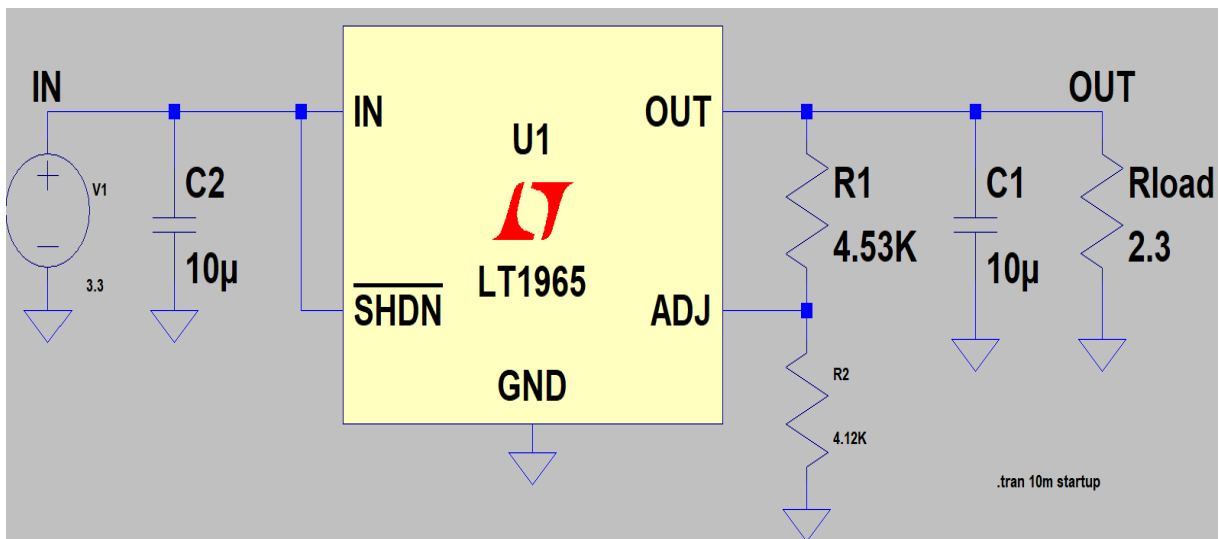

Figure 39. 3.3V to 2.5V LDO.

After getting the voltage to 2.5V a standard inverter circuit will be implemented to get the desired -2.5V. The inverter circuit is as follows:

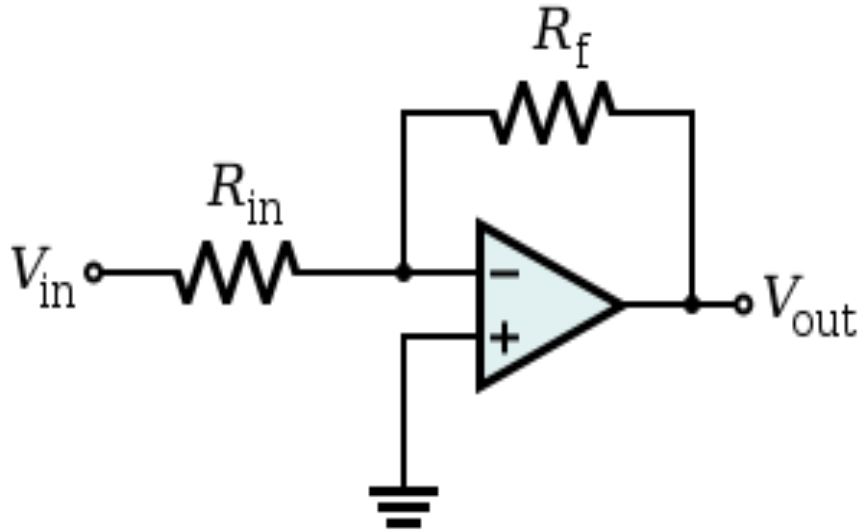

Figure 40. Op amp inverting circuit.

Simply maintaining a 1:1 ratio between R_f and R_{in} will effectively invert the voltage from the input to the output while keeping it at 2.5V. For this Circuit a Texas Instruments TLV9002 general purpose operational amplifier will be implemented. The next step down in the transceiver takes the 2.5V down to 1.8V for use in the AC to DC converter and the Digital Signal Processor again. For this step a Texas Instruments TPS746 will be integrated into the following circuit:

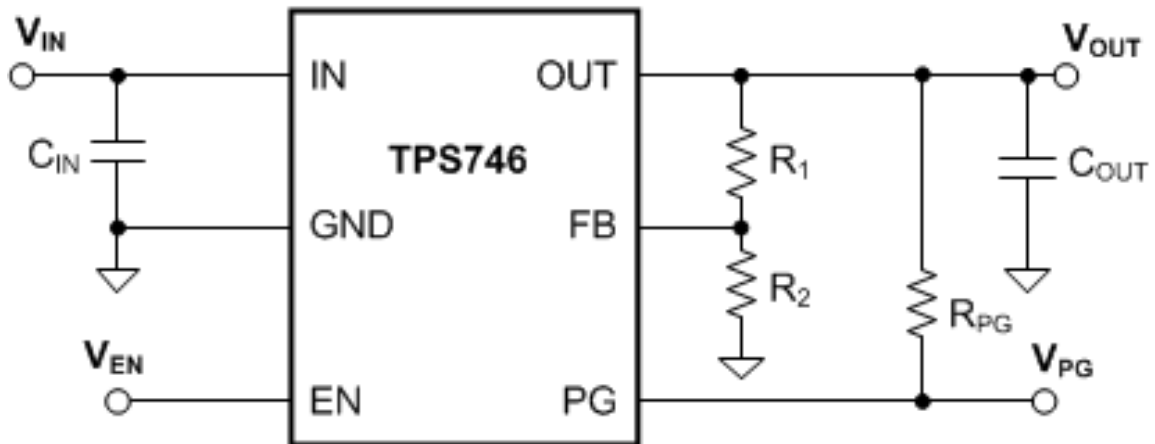

Figure 41. 2.5V to 1.8V LDO regulator schematic.

For the desired 1.8V output where $V_{FB} = 0.55$ V and can be adjusted up to 5.5V based the ratio of R_1 and R_2 are as follows

$$\frac{R_1}{R_2} = (1.8/V_{FB} - 1)$$

With C_{in} and C_{out} being greater than 1 μF , but less than 200 μF . The Ratio of R_1 over R_2 is then equal to 2.27. Now the only voltage left for the RF transceiver board is the LNA, which has a varying voltage of 1 to 5 V. Stepping down the voltage like this helps deter the parasitics from interfering with the transmission of the signals.

5.9 Wireless Communication

If the decision is made to use an external device to transmit and receive data, there must be a wireless communication link between the devices and the microcontroller. This is imperative so as to make the setup and use of this system easy and simple for the user. Wireless communication would allow the system to take information from the users and send information to the users to be displayed so that the users know different accolades during and after use of the system.

Wireless communication would also allow the system to be more presentable since there would be no wires running from the devices that control the motors from the bicycles and send information to and from the bikes and the Arduino. This also allows the system to be controlled by an application for displaying information to, and taking information from, the users instead of having a need for an LCD and a way for the users to input parameters to begin the system.

This system is intended to be used in an indoors at a gym, so we will need a communication protocol that can handle a lot of noise from many other smartphones and devices. With wireless communication, there is a lot of interference and it is extremely hard to pass information between devices efficiently.

There are many requirements to be met when implementing our wireless communication within the system.

- Low power usage
- Low cost
- Interference from other electronics
- Range
 - Not very large range, 10 meters will suffice

5.9.1 Zigbee Standard

Zigbee is a LAN wireless protocol from IEEE 802.15.4. This standard is used for low-power low data rate projects that are in close proximity and have a need for wireless connectivity. These projects are normally wireless control and monitoring applications. The distance of this standard is limited by its low power consumption and is limited to 10-100 meters. Devices are able to send the further distances by using the mesh network of intermediate devices to reach the distant ones. This standard is typically used in applications that require long battery life and secure networking, and that can tolerate low data rates. The Zigbee standard operates in 2.4 GHz for home use, data rates vary from 20 kbit/s to 250 kbit/s, and allows up to 65,000 nodes per network.

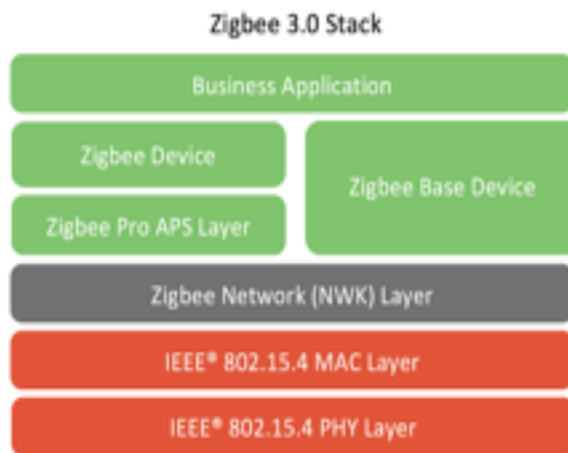

Figure 42. The Zigbee protocol stack

5.9.1.1 XBee and Arduino

XBee is a module created by MaxStream that allows the Arduino board to communicate wirelessly using Zigbee. This module meets all the standards set forth by the IEEE 802.15.4 protocol. It can communicate up to 100 feet indoors or 300 feet outdoors, runs on a 2.4 GHz bandwidth, and uses 1 mW of power.

The XBee module is connected to the Arduino board through use of the XBee Shield. The XBee Shield is interfaced to the Arduino through existing pins on the board. From there, the programmer is able to configure the XBee Shield through the Arduino.

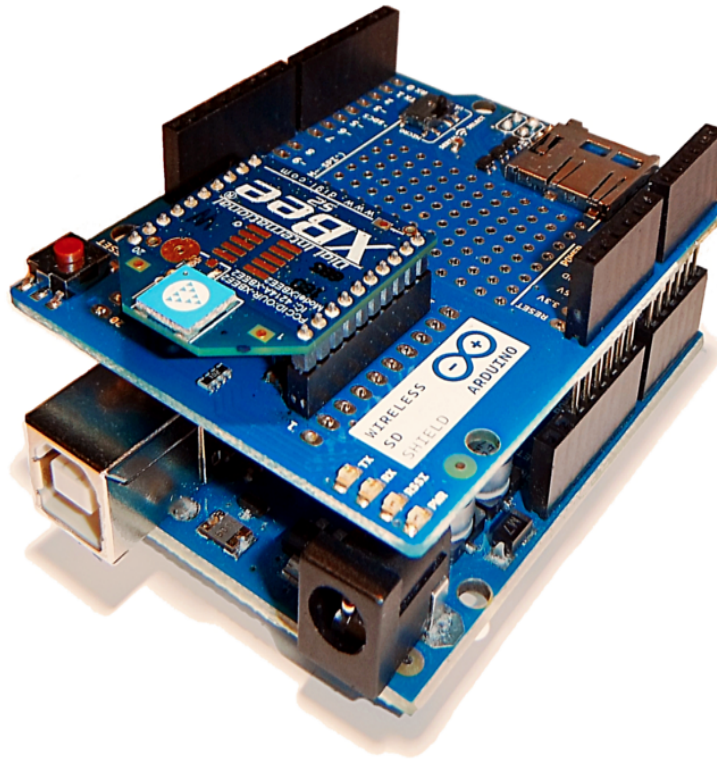

Figure 43. Arduino board with a XBee Shield attached

5.10 Bluetooth Low Energy

Bluetooth Low Energy (BLE) is a PAN wireless protocol from IEEE 802.15.1. BLE is desirable for this system because of the aspect of using an application on a phone as a communication device. BLE is also a low power protocol that is used to communicate with devices over short distances. The BLE protocol stack is shown in Figure 44 below:

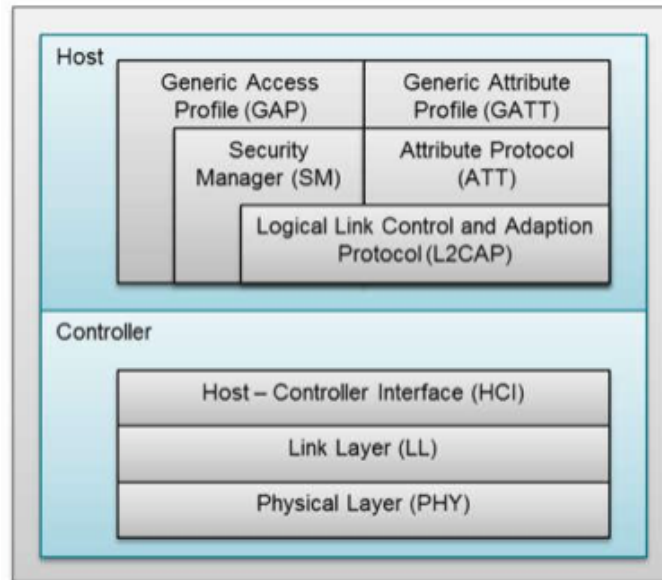

Figure 44. The BLE protocol stack

5.10.1 Generic Access Profile

BLE uses a Generic Access Profile (GAP) for controlling connections in bluetooth. GAP is what makes your device visible to outside world and decides how devices can interact with each other. GAP will set roles for devices, namely the central devices and peripheral devices. Peripheral devices are small, low power, resource constrained devices that connect to a much more powerful central device. Central devices are usually the mobile phone that you connect to.

5.10.2 Generic Attribute Profile

Once the devices are setup, the Generic Attribute Profile (GATT) defines the way the two BLE devices transfer data back and forth using services and characteristics. GATT makes use of the Attribute Protocol (ATT), which is used to store services, characteristics and related data in a simple lookup table. An important concept to know is that a BLE peripheral can only be connected to one central device at a time. However, a single central device can have multiple peripherals connected to it. This concept is illustrated in Figure 45 below:

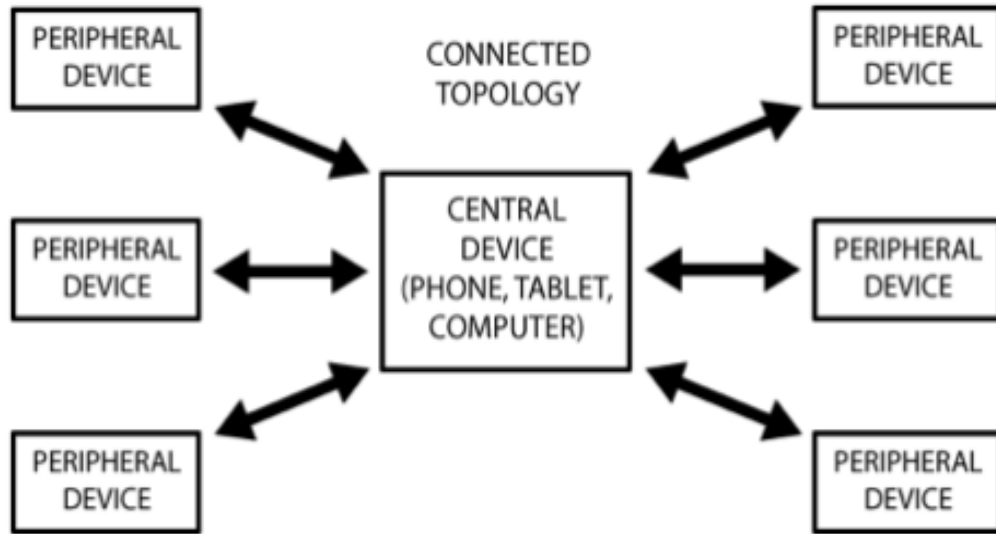

Figure 45. Topology of BLE connected devices

5.10.3 GATT Transactions

An important concept with the GATT is the server/client relationship. The peripheral is known as the GATT server, which holds the lookup data and service and characteristic definitions. The GATT client, which is the central, sends requests to the server. All transactions are started by the client, which receives a response from the server. The data exchange process is shown in Figure 46 below:

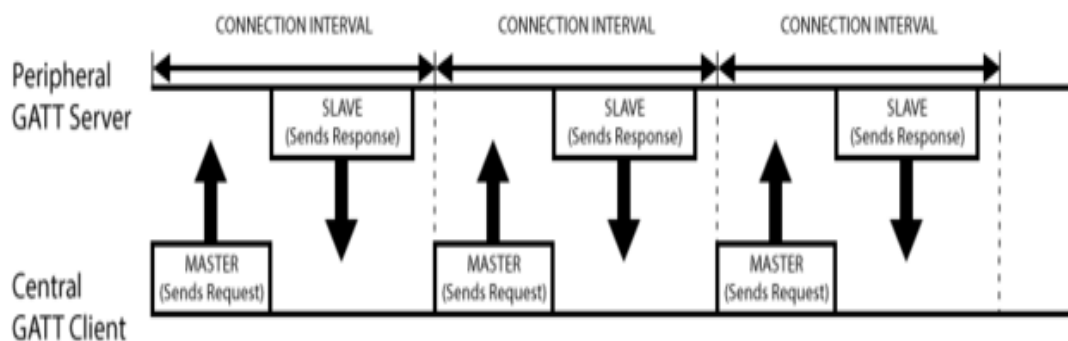

Figure 46. Typical data exchange between BLE devices

GATT transactions in BLE are based on high-level, nested objects called Profiles, Services, and characteristics. The transactions are illustrated in Figure 47 below:

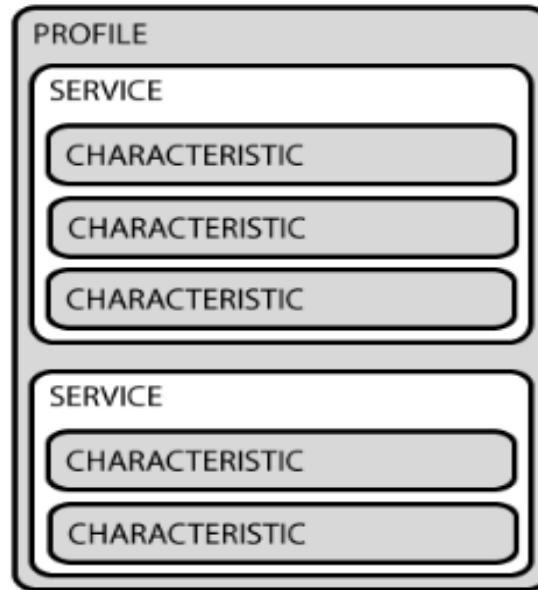

Figure 47. Nested object topology in BLE

A profile does not actually exist on the BLE peripheral itself, it is a pre-defined collection of services that have been compiled by either Bluetooth SIG or by peripheral designers. Services are used to break up data into logical entities, and contain characteristics. A service can have multiple characteristics, and each service distinguishes itself from other services using a unique ID. The lowest level concept in GATT transactions is the characteristic. The characteristic encapsulates a single data point, which may contain an array of related data. Each characteristic also distinguishes itself with a unique ID like the services.

5.10.4 BLE and Arduino

BLE is a module that allows the Arduino board to communicate wirelessly using Bluetooth low energy. This module meets all the standards set forth by the IEEE 802.15.1 protocol.

The BLE module is connected to the Arduino board through use of the BLE Shield. The BLE Shield is interfaced to the Arduino through existing pins on the board. From there, the programmer is able to configure the BLE Shield through the Arduino using the built-in Arduino library called CurieBLE. This library makes communication between the Arduino and BLE attachment easy because it will all be in a high-language C/C++ and removes programming in low-level languages.

5.11 Wi-Fi

Wi-Fi was created by the company Wi-Fi Alliance and is technology used for radio wireless local area networking of devices based on IEEE 802.11 standards. Wi-Fi is the dominant form of wireless communication as of present day and is widely accepted by all of its users. The devices that are able to use Wi-Fi connect to the Internet via a WLAN and a wireless access point. Wi-Fi most commonly uses the 2.4 GHz UHF and 5.8 GHz SHF ISM radio bands. Each of these bands are divided into multiple channels so that multiple users can be on the same bandwidth at the same time. Although Wi-Fi is the most widely accepted wireless communication protocol, it does have some weaknesses. One being that it is susceptible to eavesdropping. Anyone that is within range of a wireless network interface controller can attempt to access the network. Eavesdropping is when an attacker is able to gain access to a Wi-Fi network and is able to take any information that they want from the devices connected to the network. Wi-Fi networks combat this by having passwords on their network, but the protection is only as good as the password that the network owner gives it.

IEEE 802.15 is a standards committee of the Institute of Electrical and Electronics Engineers that dictate the standards for wireless area networks. For the purposes of the Battle of the Bikes we need to evaluate IEEE 802.15.1 however. 802.15.1 is section of 802.15 that is specifically for Wireless Personal Area Networks (WPAN) and Bluetooth. The standards in place for this section directly affect the MAC and Physical layers of computer communication networks.

5.12 Comparison of Wireless Communications

A comparison of Zigbee and BLE is shown below:

	BLE	Zigbee	Wi-Fi
Network Type	PAN	PAN	LAN
Range	5-10 meters	10-30 meters	20 meters
Throughput	270 Kb/s	20-250 Kb/s	900 Mb/s
Transmit Power	2.5 mW	Up to 100 mW	100 mW

Table 27. Comparison of BLE and Zigbee

Based off our research we chose to go with BLE due to the fact that creating our own Wi-Fi would be extremely difficult due to the interference from other devices. Not only was that a factor, but due to the fact that we only need one device to interact with one other device, we saw no need for such big networks. Also, BLE is extremely efficient in that it has very low power consumption to do the same work as these other protocols. This is appealing due to the fact that we want our system to use as little power as possible because we want the users to recharge the battery as they ride and generators are not 100% efficient.

5.13 Transceiver Design

The bikes will have Wi-Fi transceivers to communicate with each other and to relay the data to the user interface. The transmitter will radiate in the 2.4 GHz ranger and the receiver will have the ability to process the data in real time.

5.13.1 Radio Frequency Fundamentals

In the context of a transceiver operating within the 2.4 GHz range, radio frequency is an analog signal which travels in the Ultra High Frequency band due to electromagnetic radiation. To succeed in transmitting RF with the least loss possible certain parameters must be designed to.

S-parameters, or scattering parameters are commonly used in RF applications due to measurements being taken in power versus current or voltage. S-parameters are taken in reference to a matched load condition. This occurs when the input impedance of an element matches the output impedance of that same element. Typically, the load impedance is chosen to match the characteristic impedance, Z_0 .

$$Z_0 = \sqrt{\frac{R + j\omega L}{G + j\omega C}}$$

Where R is the resistance per unit length, L is the is the inductance per unit length, G is the conductance per unit length and C is the capacitance per unit length of the transmission line.

Figure 48 illustrates a two-port network measured in S-parameters.

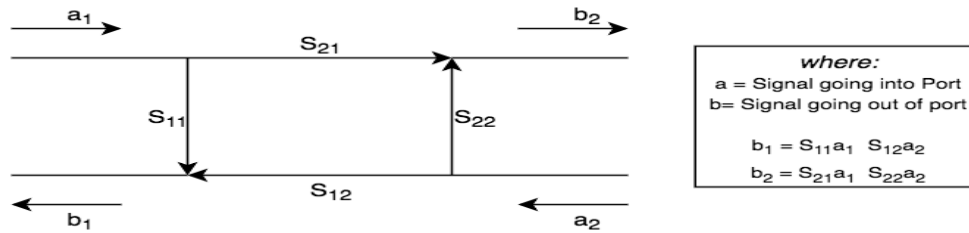

Figure 48. S-parameter Port Representation

S_{11} is the input reflection coefficient with the output port matched to Z_0 . The reflection coefficient is ideally as low as possible. This is a measure of how close in impedance matching the input port is to the output.

$$S_{11} = \left. \frac{b_1}{a_1} \right|_{a_2 = 0}$$

S_{21} is the forward transmission with the input port matched to Z_0 . Due to reciprocity, this value is ideally the same as S_{12} .

$$S_{21} = \left. \frac{b_2}{a_1} \right|_{a_2 = 0}$$

S_{12} is the reverse transmission, also known as isolation, with the output port matched to Z_0 . It is an indication of the amount the input signal propagates to the output port.

$$S_{12} = \left. \frac{b_1}{a_2} \right|_{a_1 = 0}$$

S_{22} is the output reflection coefficient with the input port matched to Z_0 . The reflection coefficient is ideally as low as possible.

$$S_{22} = \left. \frac{b_2}{a_2} \right|_{a_1 = 0}$$

The previous parameters are typically translated into that logarithmic scale for analysis. Which can be calculated using Table 28.

Parameter	Decibel Equation
S_{11}	$S_{11dB} = 20 \cdot \log(S_{11})$
S_{21}	$S_{21dB} = 20 \cdot \log(S_{21})$
S_{12}	$S_{12dB} = 20 \cdot \log(S_{12})$
S_{22}	$S_{22dB} = 20 \cdot \log(S_{22})$

Table 28. S-Parameters to dB

Due to the property that all transmission mediums are non-ideal and lossy, the S-parameters represented in decibels are always negative. This is because the ratio is always represented as the output over the input and the log of a decimal is negative. S_{11} and S_{22} should be as low as possible in both linear and log scales. Ideally these parameters should be below -30 dB at center frequency. This would mean that ports are matched well and the transmission will be the most efficient. S_{21} and S_{12} should be as close to 0 dB as possible. The Wi-Fi transceiver will use a three-port network called a Wilkinson Power Divider as well as a four-port network called a quadrature coupler. These networks will be defined in the *Transceiver Elements* section.

5.13.2 RF Printed Circuit Board

The following materials contain beneficial properties, such as low loss, for an RF circuit operating at 2.4 GHz and will be considered. The lower the dielectric constant the more ideal the material. There is more design flexibility the thinner the substrate. As the dissipation factor goes to zero, the more efficient the transmission line is. Thermal conductivity values are better when they are higher due to many RF networks having high power elements needing to dissipate heat.

	RO4003	ASTRA MT77	AD250C
Vendor	Rogers Corporation	Isola Group	Rogers Corporation
Effective Dielectric Constant	3.38	3.00	2.50
Substrate Thickness	0.020"	0.020"	0.020"
Dissipation Factor	0.0027	0.0017	0.0014
Thermal Conductivity	0.71	0.45	0.30
Cost per Sheet	*Free	Quote Requested	*Free

Table 29. Substrate Materials

- indicates a request for free sampling material has been placed

Based on the Dielectric constant as well as how easily it is sourced, RO4003 will be used.

The transmission line most commonly used in PCBs is the microstrip, which can be constructed directly out of the laminate material. The following equations can be used to calculate the effective dielectric constant of the microstrip line.

For $\left(\frac{W}{H}\right) < 1$:

$$E_{eff} = \frac{E_r + 1}{2} + \frac{E_r - 1}{2} \left[\frac{1}{\sqrt{1 + 12\left(\frac{H}{W}\right)}} + 0.04\left(1 - \frac{W}{H}\right)^2 \right]$$

$$Z_0 = \frac{60}{\sqrt{E_{eff}}} \ln \left(8\left(\frac{H}{W}\right) + 0.25\left(\frac{H}{W}\right) \right)$$

For $\left(\frac{W}{H}\right) > 1$:

$$E_{eff} = \frac{E_r + 1}{2} + \left[\frac{E_r - 1}{2\sqrt{1 + 12\left(\frac{H}{W}\right)}} \right]$$

$$Z_0 = \frac{120\pi}{\sqrt{E_{eff} \left[\left(\frac{W}{H}\right) + 1.393 + \frac{2}{3} \ln \left(\frac{W}{H} + 1.444\right) \right]}}$$

The characteristic impedance for the microstrip transmission line should be calculated to 50 Ω . From this the ideal ratio of height to width can be determined, and thus the effective dielectric constant.

If there needs to be a change in path direction a bend can be made in the microstrip line. Though this is necessary, it often induces unwanted reflections and higher S_{11} and S_{22} parameters. The bend actually acts as a shunt, shorting some of the transmission signal to RF ground. To combat this inefficiency a Mitred bend, calculated in a percentage, can be used.

$$M = 100 \frac{x}{d} \% = \left(52 + 65e^{-\frac{27W}{20H}} \right) \%$$

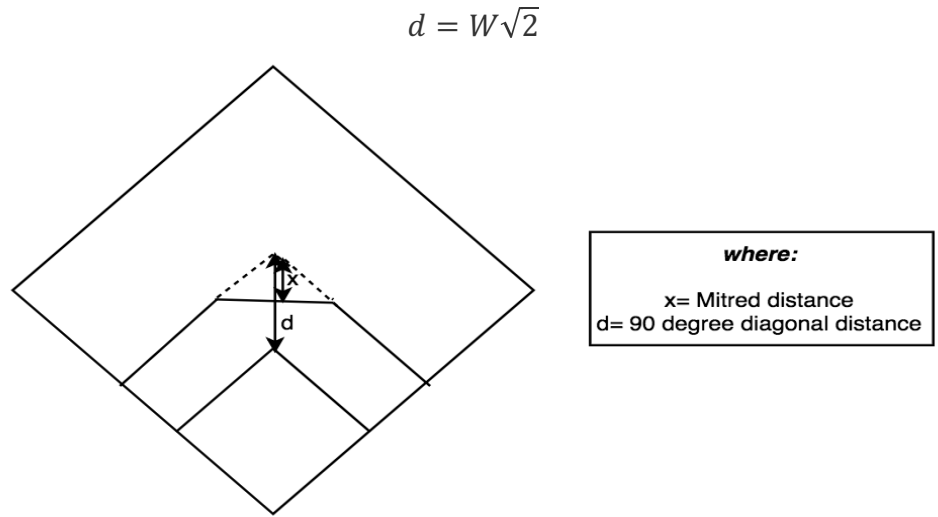

Figure 49. Mitred Bend

5.13.3 Receiver (RX) Path

The Figure 50 is a block diagram of the receive path of the transceiver.

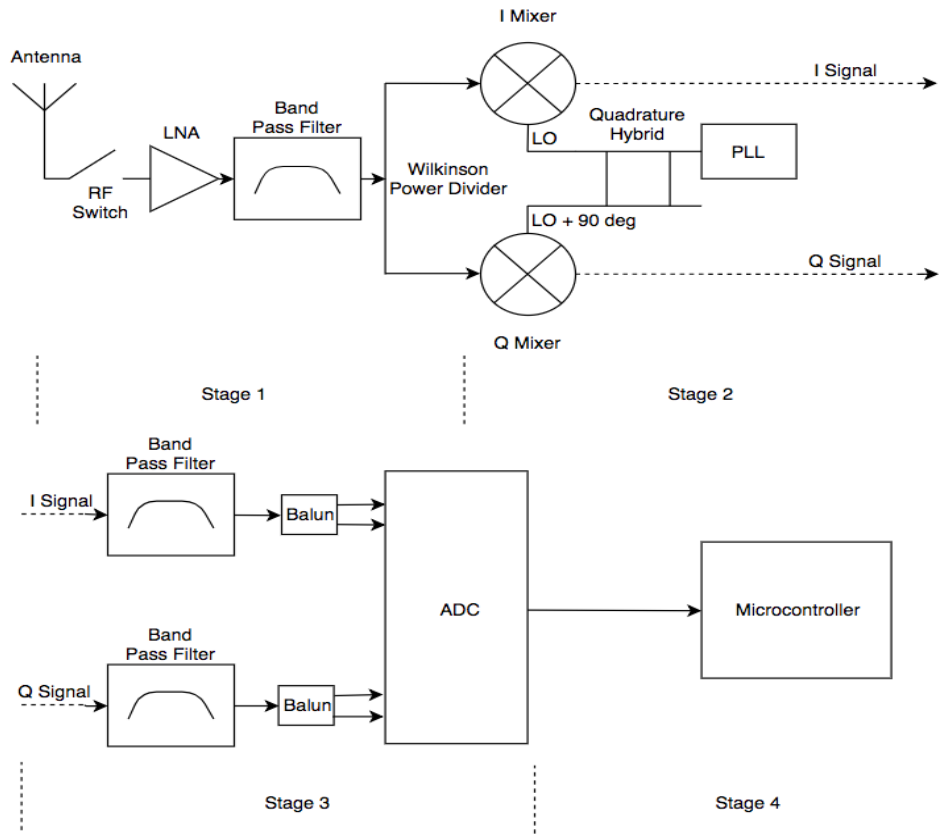

Figure 50. Receive Path of the Transceiver

5.13.4 Transmitter (TX) Path

The Figure 51 is a block diagram of the transmit path of the transceiver.

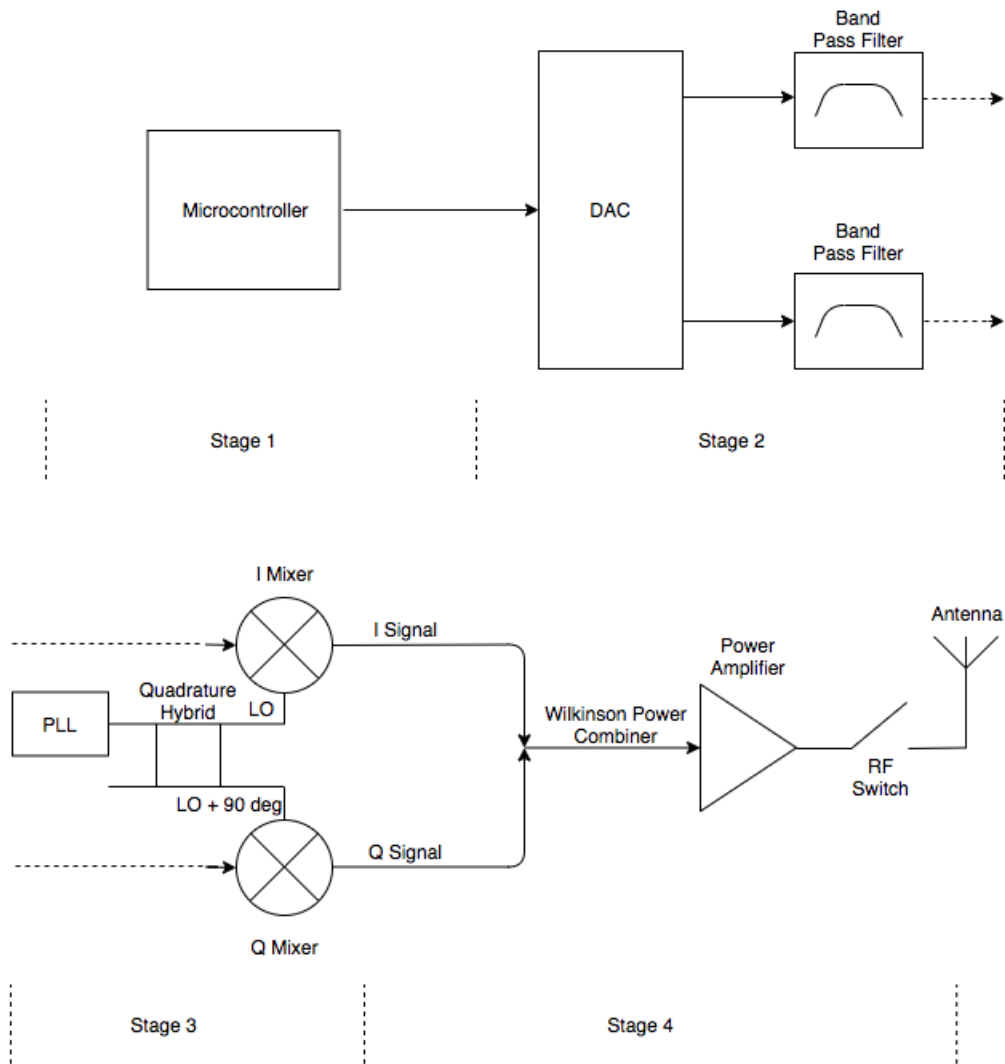

Figure 51. Transmit Path of the Transceiver

5.13.5 Transceiver Elements

Many of the same components can be used in both the receiver portion as well as the transmitter due to the fact many processes are simply the opposite in order of operations.

5.13.5.1 Analog to Digital Converter

According to Nyquist, to be able to sample an analog signal and convert to digital the sampling rate must be twice the bandwidth of a band limited channel. WLAN standards dictate a bandwidth of 22 MHz, meaning the ADC would have to sample at a rate of at least 44 MHz. Comparatively, Bluetooth has a bandwidth of 1 MHz, meaning the ADC would have to sample at a rate of at least 2 MHz. Though neither of these standards are to be used, to increase the ability to transmit effectively, the higher bandwidth will be used for reference of purchasing parts.

	MAX1193	ADS5237	AD9059
Vendor	Maxim	Texas Instruments	Analog Devices
Resolution	8-bit	10-bit	8-bit
Conversion Rate	45 MSPS	65 MSPS	60 MSPS
Input Bandwidth	440 MHz	300 MHz	120 MHz
Clock Input	45 MHz	65 MHz	60 MHz
Input Frequency Max	100 MHz	70 MHz	140 MHz
Power Consumption	57 mW	330 mW	400 mW
Analog Supply Voltage	3.0V	3.3 V	5 V
Digital Supply Voltage	1.8 V	3.3 V	5 V
I/Q Cross Talk	75 dB	91 dB	50 dB
Two Tone Intermodulation Distortion	-76.1 dBc	-85 dBc	-52 dBc
Package	28-Pin QFN	28-Lead SOIC	20-Lead SSOP
Price	\$8.96	\$12.19	\$14.95

Table 30. ADC Comparison

The MAX1193 is selected due to its superior bandwidth, price and power consumption.

5.13.5.2 Antenna

For simplicity, a microstrip patch antenna will be constructed and will be used for both transmitting and receiving signals. This also decreases the chance of interference from the opposite transmitter. A switch will be implemented to change from receiving to transmitting paths.

The microstrip antenna patch allows for both linear and circular polarization; however, only the linear polarized patch antenna will be implemented. The typical gain is around 6-7 dBi. One down fall of the patch antenna is spurious radiation. This, for example, could be a harmonic of the carrier signal or an unintended signal completely. The bandwidth of the antenna is typically very narrow, around 5%; however, with optimization techniques it can reach to be 45%. This bandwidth is determined using S-parameters as previously mentioned and setting a design constraint to a certain gain. The bandwidth of an antenna is inversely proportional to the dielectric of the substrate. Also, as the substrate thickness increases, the bandwidth does as well. The following equation illustrates the relationships described.

$$BW \approx 3.77 \left(\frac{E_r - 1}{E_r} \right) \left(\frac{W}{L} \right) \left(\frac{h}{\lambda} \right)$$

The effective dielectric constant and patch width can be calculated using the following equations.

$$E_{eff} = \frac{E_r + 1}{2} + \frac{E_r - 1}{2} \left[\frac{1}{\sqrt{1 + 12 \left(\frac{H}{W} \right)}} \right]$$

$$W = \frac{c}{2f_r} \sqrt{\frac{2}{E_r + 1}}$$

Figure 52 illustrates the variables of the patch antenna.

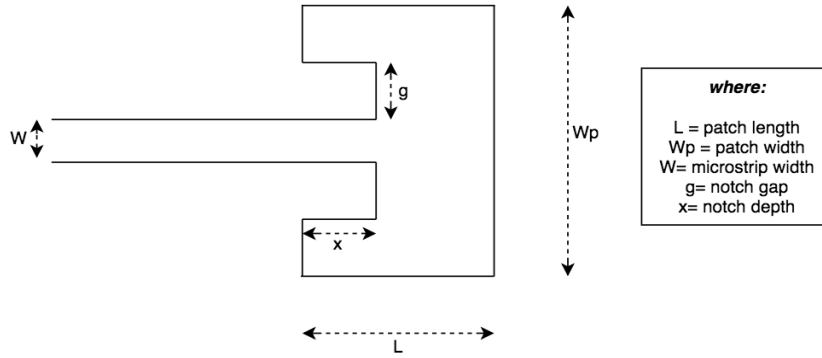

Figure 52. Microstrip Patch Antenna Parameters

To calculate the length of the antenna both the effective length (L_{eff}) and the extension length (ΔL) must be calculated.

$$L = L_{eff} - 2\Delta L$$

where:

$$L_{eff} = \frac{c}{2f_0\sqrt{E_{eff}}}$$

$$\Delta L = 0.412h \left[\frac{(E_{eff} + 0.3) \left(\frac{W}{H} + 0.264 \right)}{(E_{eff} - 0.258) \left(\frac{W}{H} + 0.8 \right)} \right]$$

The notch width is calculated using:

$$g = \frac{c * 4.65 * 10^{-12}}{\left(\sqrt{2(E_{eff})} \right) (f)}$$

where f is in GHz.

The notch depth is calculated using following equation.

$$x = 10^{-4} \left(0.016922E_r^7 + 0.13761E_r^6 - 6.1783E_r^5 + 93.187E_r^4 - 682.69E_r^3 + 2561.9E_r^2 - 4043E_r + 6697 \right) \frac{L}{2}$$

The following variables were calculated to optimize the patch antenna around 2.4 GHz as well as the RO4003 material selected for the substrate.

Microstrip Line Width (W)	44.79 mils
Patch Width (Wp)	1649.90 mils
Path Length (L)	1324.42 mils
Patch Notch Gap (g)	8.84 mils
Patch Notch Depth (x)	375.16 mils

Table 31. Patch Antenna Calculated Parameters

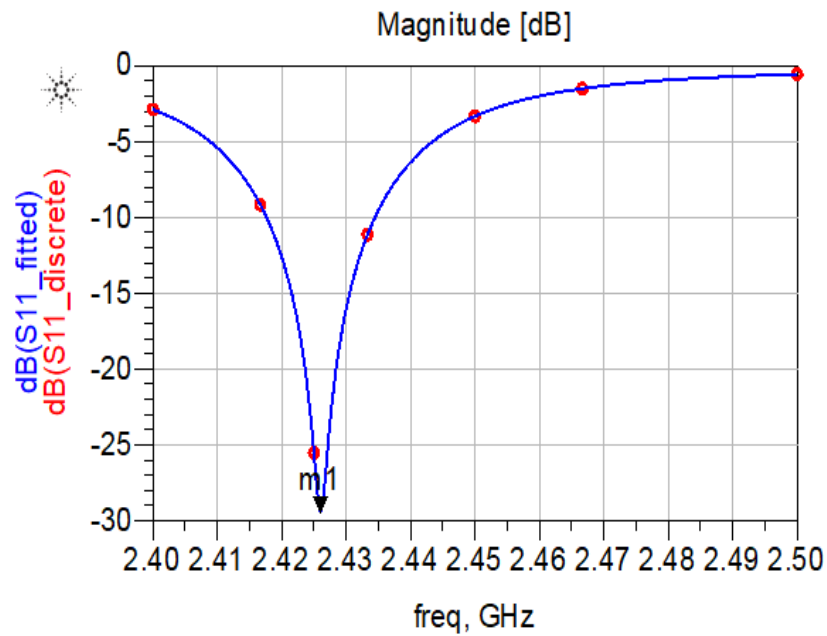

m 1 freq=2.426GHz dB(S11_fitted)=-29.462 Min

Figure 53. Microstrip Patch Antenna Port One Reflection

As Figure 54 illustrates, there is also 0-degrees of phase shifting at 2.426 GHz.

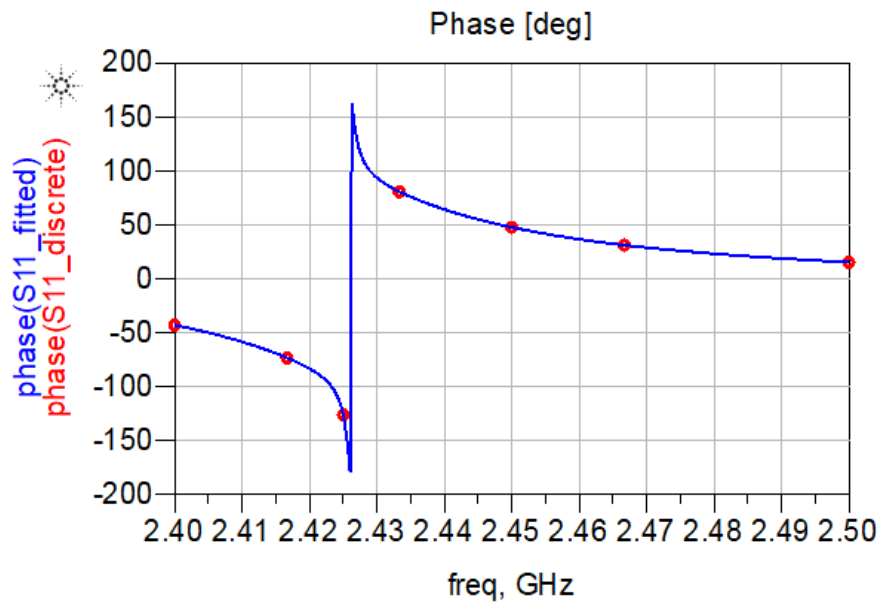

Figure 54. Microstrip Patch Antenna Port One Phase

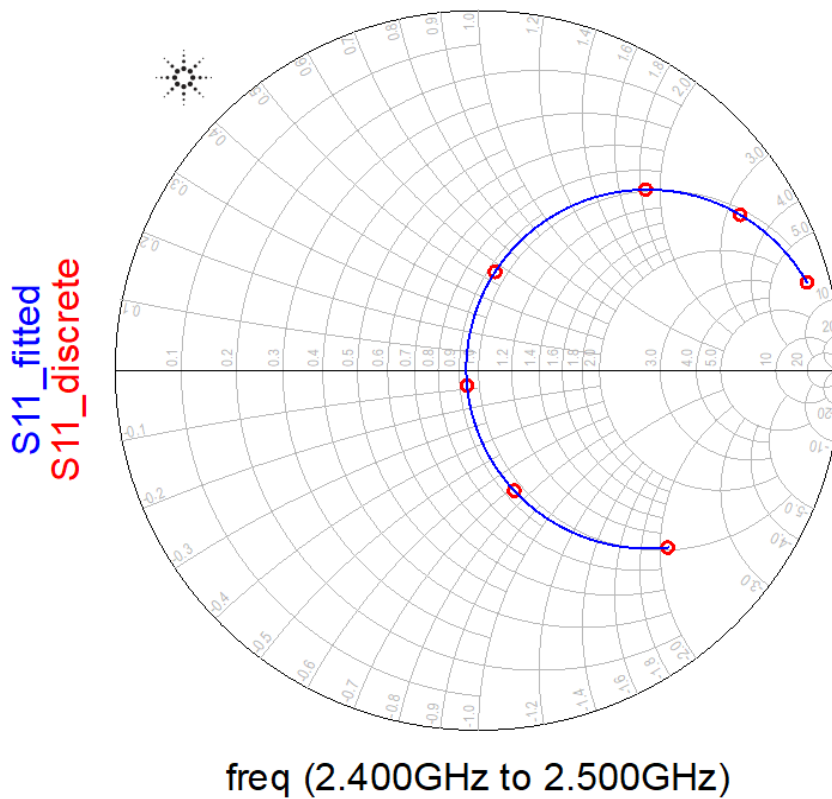

Figure 55. Microstrip Patch Antenna Smith Chart

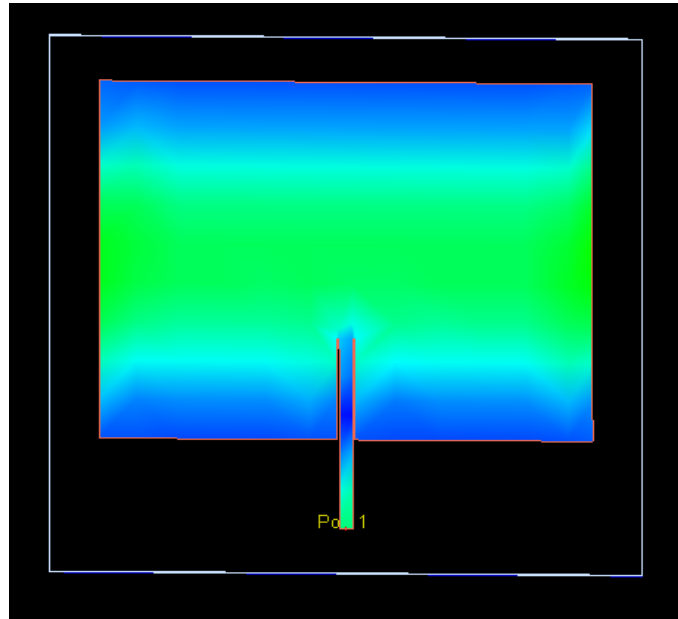

Figure 56. Advanced Design System E&M Representation of the Microstrip Patch Antenna

5.13.5.3 Band Pass Filters

Table 32 is a comparison of the 2.4 GHz band pass filter utilized in both the transmit and receive paths. The 2.4 GHz filter is used after the antenna, RF switch and the low noise amplifier on the RX path as well as prior to the RF switch and power amplifier on the TX path.

	DEA142450BT-3028A1	DEA252400BT-2030A1	LFB182G45BG7 D948
Vendor	TDK	TDK	Johanson Technology
Frequency Range	2400-2500MHz	2300-2500MHz	2400-2500MHz
Insertion Loss	0.90 dB	1.06 dB	0.90 dB
Return Loss	19 dB	19.2 dB	15 dB
Characteristic Impedance	50 Ω	50 Ω	50 Ω
Package	55.12 x 43.31 mils	98.43 x 78.74 mils	63 x 31 mils
Price	\$0.14	\$0.48	\$0.51

Table 32. 2.4 GHz Band Pass Filter Comparison

The DEA142450BT-3028A1 by TDK will be used due to the lowest return loss, highest insertions loss and lowest price.

5.13.5.4 Digital to Analog Converter

The digital to analog converter is located on the transmit path of the transceiver. It will be used to convert the data the microcontroller collects and processes from the stationary bicycle to an analog signal that can then be more effectively transmitted to the sister bike. The data is being sent in small packets with little information in each; therefore, a 10-bit DAC or less will suffice.

	AD9714	AD9708	DAC5652-EP
Vendor	Analog Devices	Analog Devices	Texas Instruments
Resolution	8-bit	8-bit	10-bit
Conversion Rate	125 MSPS	10-125 MSPS	200 MSPS
Clock Input	125 MHz	10 - 125 MHz	200 – 275 MHz
Output Frequency	60 MHz	40 MHz	40 MHz
Power Consumption	86 mW	175 mW	310 mW
Analog Supply Voltage	3.3 V	5 V	3.3 V
Digital Supply Voltage	1.8 V	5 V	3.3 V
I/Q Cross Talk	78 dB	N/A	N/A
Two Tone Intermodulation Distortion	71 dBc	45 dBc	61 dBc
Package	40-Lead LFCSP	28-Lead SOIC	48-Pin TQFP
Price	\$13.17	\$8.08	\$12.95

Table 33. DAC Comparison

AD9708 will be used due to the clock input range. For proper synchronization all components utilizing a clock should use the same one. The package size and price are also contributing factors.

5.13.5.5 Downconverter Mixer

The down converter mixer is located on the receive path of the transceiver. It integrates the use of a local oscillator (LO). The LO is created with the phase-locked loop. This signal is then split through a quadrature hybrid into an I signal, meaning in-phase, and Q signal, meaning quadrature. This hybrid is simply made by creating two microstrip paths. One, the quadrature signal, propagates on the path that is the equivalent of 90 degrees longer than the in-phase signal. These signals mix with the 2.4 GHz signal being received to create an intermediate frequency (IF). The downconverter mixer allows for this IF to still contain all of the information from the carrier signal. At the lower, intermediate, frequency it can then be more easily processed upstream.

	TRF37C32	LTC5542	MAX2042A
Vendor	Texas Instruments	Linear Technology	Maxim
Input Frequency Range	1700 – 3800 MHz	1600 – 2700 MHz	1600 – 3900 MHz
IF Frequency Range	30 – 600 MHz	5 – 500 MHz	50 – 500 MHz
Channel Isolation	45 dB	35 dB	38 dB
Gain	10dB	8dB	-7.2 dB
Noise Figure	9.5 dB	9.9 dB	7.25 dB
Power Dissipation	920 mW	660 mW	310 mW
Supply Voltage	3.3 V	3.3 V	3.3 V
Two Tone Intermodulation Distortion	26 dBm	26.8 dBm	33 dBm
Package	32-Pin WQFN	20-Lead QFN	20-Lead TQFN
Price	\$15.13	\$9.00	\$12.95

Table 34. Down Converter Mixer Comparison

LTC5542 is selected due to relative power loss, distortion and gain figures. The intermediate frequency needs to be 100 MHz or less for the selected analog to digital converter. An adequate value for LO can be obtained using the following equations.

For high-side injection:

$$LO = IF + RF_{in}$$

For low-side injection:

$$LO = RF_{in} - IF$$

Low-side injection will be used, therefore, the input LO will be 2350 MHz.

5.13.5.6 Low Noise Amplifier

A low noise amplifier is used in the RX path of the transceiver. This type of amplifier allows the incoming signal to increase in power while allowing the noise to increase by a fraction of the signal. The LNA thus aids in the signal-to-noise ratio of the receive system and allows for easier differentiation of the signal from the noise when it is being processed.

	SGA8343Z	BGU7224X	SST12LN01-QU6E
Vendor	Qorvo	NXP Semiconductors	Microchip
Frequency Range	DC - 6 GHz	2.4 - 2.5 GHz	2.4 - 2.5 GHz
Gain	16.5 dB	15 dB	13.5 dB
Noise Figure	0.94 dB	1 dB	1.5 dB
Two Tone Intermodulation Distortion	27.8 dBm	34 dBm	-
Supply Voltage	2-3 V	3-3.6 V	3.3 V
Package	SOT-343	HXSON6	UQFN
DC Blocking	No	Yes	Yes
Price	\$0.60	\$0.68	\$1.04

Table 35. LNA Comparison

BGU7224X is selected due to internal DC blocking circuitry and gain figure.

5.13.5.7 Phase-Locked Loop

The phase-locked loop creates a stable higher frequency from a lower reference frequency. Figure 57 illustrates a basic PLL, in which PD is the phase detector, VCO is the voltage controlled oscillator. The error detector outputs current in pulses. The filter is current controlled with a voltage output and is used to normalize the pulses before being sent to the VCO. This increase or decrease in voltage effectively tunes the voltage controlled oscillator to synch the frequency with the reference.

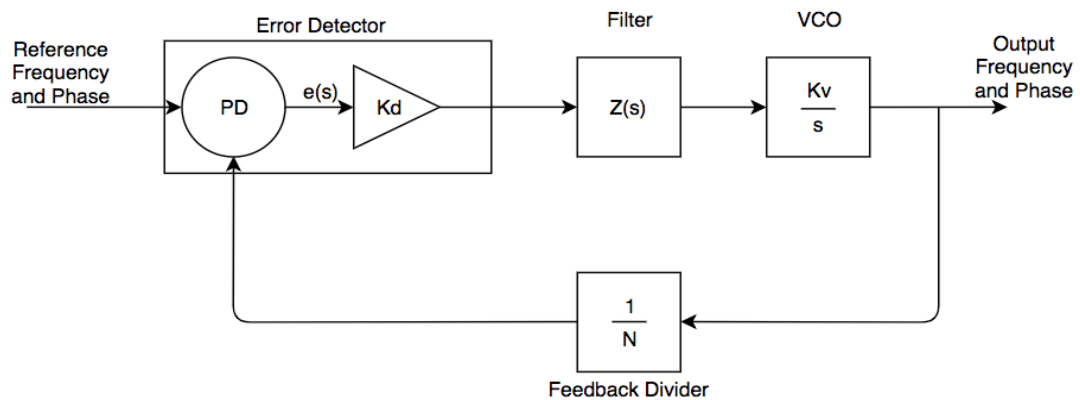

Figure 57. Typical Phase-Locked Loop Transfer Function Block Diagram

Where the output frequency (F_0) and phase are determined by the following equations.

$$F_0 = N(F_{REF})$$

$$\phi_0 = N(\phi_{REF})$$

N is the feedback factor.

	ADF4360-1	ADF4360-1BCPZRL7	ADF4212L
Vendor	Analog Devices	Texas Instruments	Analog Devices
Input Frequency	10-250 MHz	5 - 80 MHz	10-150 MHz
Output Frequency	2050 - 2450 MHz	553 - 3132 MHz	1000 - 2400 MHz
Supply Voltage	3.3 V	3.0 V	3.0 V
Price	\$6.91	\$12.04	\$5.91

Table 36. Phase-Locked Loop Comparison

The ADF4360-1 is selected due to the input and output frequency ranges.

5.13.5.8 Power Amplifier

The power amplifier is needed to boost the power signal before the antenna transmits it so the signal can propagate through air to the transceiver on the other bicycle. Amplification allows a greater differentiation between high and low values as well as the signal strength about the noise floor. It is needed to ensure noise does not corrupt the signal and it can be processed on the sister microcontroller.

	SE2604L-R	CC2595RGTR	SST12LP07
Vendor	Skyworks Solutions, Inc.	Texas Instruments	Microchip Technology
Frequency Range	2.4 - 2.5 GHz	2.4 - 2.4835 GHz	2.4 - 2.5 GHz
Output Power	26 dBm	20.7 dBm	22 dBm
Gain	32 dB	-	29 dB
Return Loss	15 dB	15 dB	-
Current Pull	410 mA	30 mA	230 mA
Supply Voltage	3.3V	3V	3.3V
Reference Voltage	-	3.3V	2.8V
Enable Pin Impedance	10 k Ω	-	110 Ω
Package	QFN	QFN	16-contact VQFN
Price	\$1.92	\$1.69	\$0.74

Table 37. Power Amplifier Comparison

The SE2604L-R will be used due to its ability to generate its own internal voltage reference, as well as superior output power figure.

5.13.5.9 Quadrature Hybrid

The LO signal created in the Phase-Locked Loop is split into an I and Q signal using a quadrature hybrid. The I signal is in-phase and Q signal, meaning quadrature, is out of phase by 90 degrees. The quadrature hybrid is a completely passive circuit that uses variations in width and length of the transmission line to split a signal so that one output is lagging 90 degrees from the other. The line is taken to have a characteristic impedance (Z_0) of 50 Ω . The following diagram illustrates the quadrature hybrid with two “boxes.” The more

sections added to the quadrature, the better the bandwidth. The tradeoff with this is a increase in the reflection coefficient; therefore, not too many sections should be added to ensure an adequate amount of power propagates to the output.

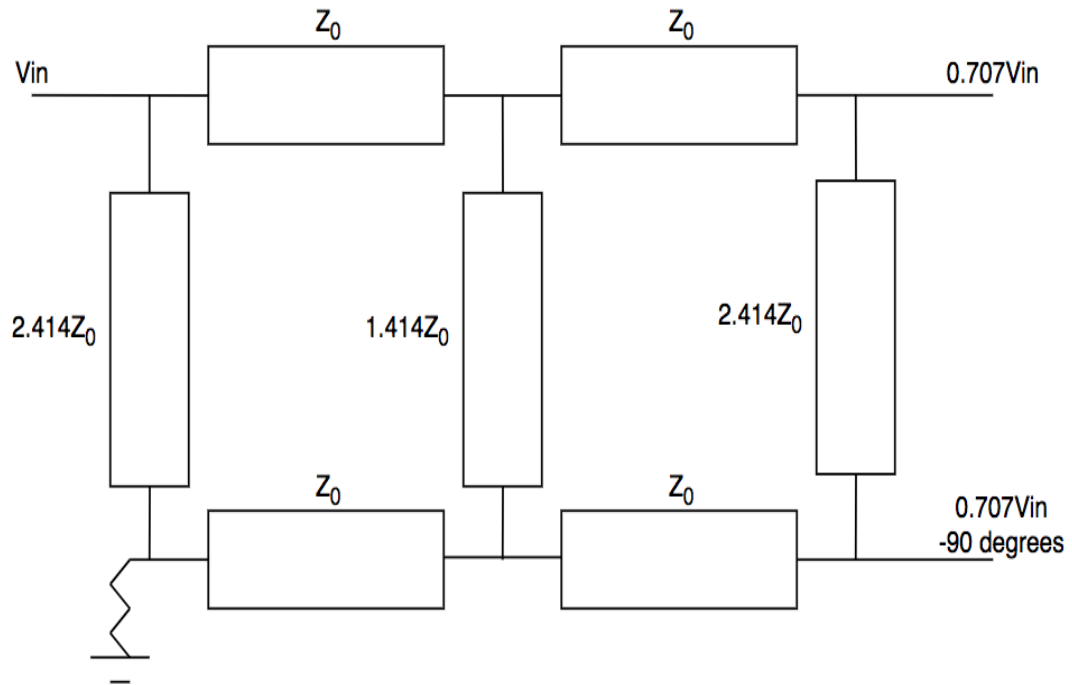

Figure 58. Broad bandwidth Quadrature Hybrid

Where the width of Z_0 is equivalent to 44.79 mils.

5.13.5.10 RF Balun

The ADC takes a 50Ω differential signal. Therefore, both the I and Q signals need to pass through a balun after the low pass filter. This balun then splits the 50Ω unbalanced signal to a 50Ω balanced signal by creating the differential pair. A differential pair is when one of the signals is shifted 180 degrees.

	2450BL15B050	HHM17139B1	BD2425N100ATI
Vendor	Johanson Technology	TDK	Anaren
Frequency Range	2.4 – 2.5 GHz	2.4 – 2.5 GHz	2.3 – 2.6 GHz
Input Impedance	50 Ω	50 Ω	50 Ω
Differential Impedance	50 Ω	50 Ω	50 Ω
Insertion Loss	1 dB	0.7 dB	0.7 dB
Phase Difference	180 ± 10	180 ± 10	180 ± 7
Amplitude Difference	2 dB	2 dB	0.3 dB
Maximum Input Power	3 W	-	0.75 W
Package Size	0805	0603	0404
Price	\$0.12	\$0.11	\$0.31

Table 38. RF Balun Comparison

The 2450BL15B050 is chosen due to price and the maximum input power.

5.13.5.11 RF Switch

The RF switch will operate with the aid of the microcontroller. The microcontroller will turn on the voltage regulator responsible for the switch when it is time to transmit. There will then be a 1.5 ms delay before the microcontroller begins to send data due to a worse case timing situation for the regulator. When the RF switch is off, it will be in receive mode. When the switch is on it will allow to transmit.

	SKY13351-378LF	CG2164X3	MASWSS0202
Vendor	Skywork Solutions Inc.	CEL	MACOM
Frequency Range	20 MHz – 6 GHz	50 MHz – 6 GHz	DC – 6 GHz
On/Off Time	100 nS	30 nS	35 nS
Insertion Loss	0.35 dB	0.50 dB	0.55 dB
Isolation	24 dB	23 dB	25 dB
Linearity	+50 dBm	+55 dBm	+52 dBm
Maximum Input Power	+26 dBm	+32 dBm	+32 dBm
Control Voltage 1	0 V	0 V	0 V
Control Voltage 2	2.7 V	3 V	3 V
Application	WLAN 802.11 a/b/g/n networks	wireless LAN applications	802.11a + b/g Applications
Price	\$0.42	\$0.45	\$0.65

Table 39. RF Switch Comparison

The MASWSS0202 is selected due to the isolation figure and the maximum input power value.

5.13.5.12 Up Converter Mixer

The up converter mixer is located on the transmit path of the transceiver. It integrates the use of a local oscillator (LO) as well. The Intermediate Frequency is mixed with the LO to create the 2.4 GHz output signal being transmitted. The up converter mixer allows for this RF output to still contain all of the information from the IF signal.

	LT5579	LT5578	MAX2042A
Vendor	Linear Technology	Linear Technology	Maxim
Input Frequency Range	1500 – 3800 MHz	400 – 2700 MHz	1600 – 3900 MHz
IF Frequency Range	0 – 1000 MHz	0 – 600 MHz	50 – 500 MHz
Channel Isolation	63 dB	60 dB	38 dB
Gain	2.6 dB	1.4 dB	-7.2 dB
Noise Figure	9.9 dB	8.6 dB	7.25 dB
Power Dissipation	740 mW	590 mW	310 mW
Supply Voltage	3.3 V	3.3 V	3.3 V
Two Tone Intermodulation Distortion	27.3 dBm	24.3 dBm	33 dBm
Package	24-Lead QFN	24-Lead QFN	20-Lead TQFN
Price	\$11.99	\$7.50	\$12.95

Table 40. Up Converter Mixer Comparison

LT5578 is to be implemented do to price, power dissipation and a low noise figure.

5.13.5.13 Wilkinson Power Divider/ Combiner

The Wilkinson power divider is a three port network utilized to create a two outputs from a signal input that are both in phase and of the same magnitude in power. It utilizes a resistor for isolation in between the two outputs. The below illustrates the necessary parameters to create the Wilkinson power divider. $\lambda/4$ shows the length of each section in the split should be the equivalent of 90 degrees. Z_0 is the characteristic impedance, which is 50Ω . The isolation resistor should be the equivalent of 100Ω .

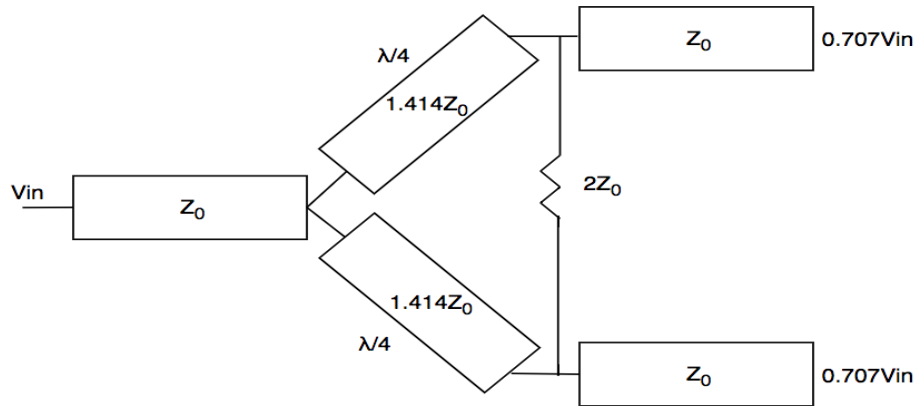

Figure 59. Wilkinson Power Divider/Combiner

5.14 Software

The software of the Battle of the Bikes will be used for presenting data to the user while the system is in use and when the game is over. The data will be presented to the user via wireless communication between the microcontroller and the device being used to display the information.

Before the system can be used, each user must enter information to set up the game. The information that is entered will be used to do calculations to be presented to the user and initialize the game. These parameters will be taken in by simple text boxes on the user's device and will be sent to the microcontroller when the button is pressed to send the information.

While the system is in use it will have to keep track of the distance travelled, current speed, and the power up level of each user. The distance travelled will be in the form of a bar graph that slowly builds up as the user pedals closer to the end goal. The current speed and power up level will be presented as simple texts to the user. There will also be a red button at the bottom of the screen that allows the user to activate their power up. When the button is pushed, a signal will be sent to the microcontroller to also forward a signal to the motor on the other bike to either increase or decrease the tension for a set amount of time.

At the end of each session, each user will have an end-game display on their device. This display will include whether the user won or loss, how long it took them to travel the distance that was set, the average and top speed, and how many calories were burned during use. Each of these values will be sent to the display in a clear, easy to read fashion. An example of initialization, in-use, and end-game displays are shown below:

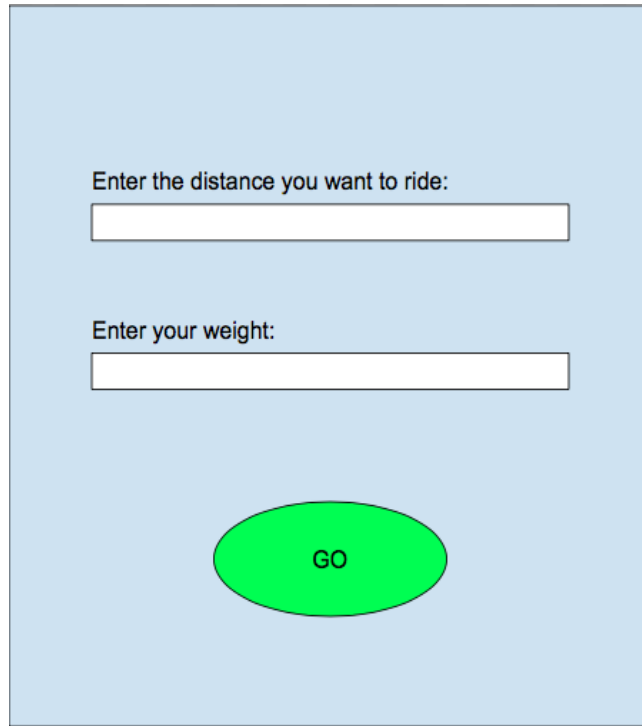

Figure 60. Prototype Initialization GUI



Figure 61. Prototype in-use GUI

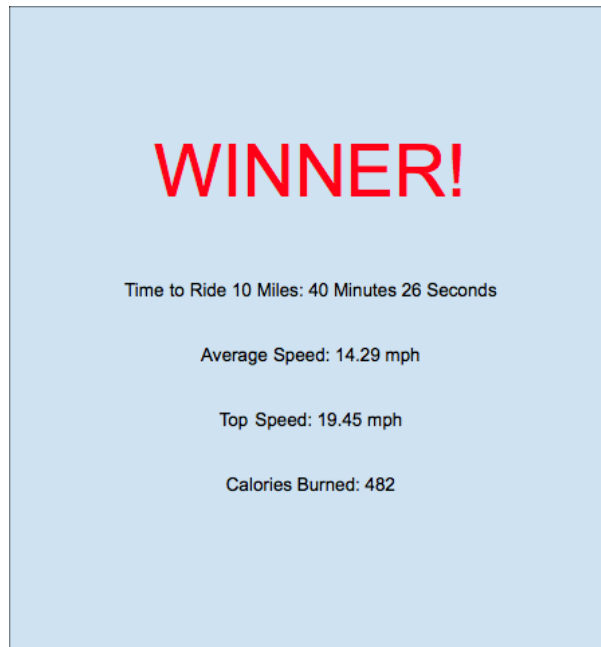

Figure 62. Prototype end-game GUI

5.14.1 Phone Application

In order to use a phone application for this system, the phone will have to be able to communicate with our microcontroller using the wireless communication that we decide to use for the system. Through the use of an application on a phone, the users experience will be much more enjoyable.

To connect to the system will be as simple as connecting to any other Bluetooth device. The system will have directions on it specifying the name of that exact system so that the users' phones can transmit and receive data from the correct source. The setup for the game can be made very simple by having the user enter information needed for initialization of the game into text boxes and having a button to send the information when the user is ready. After that, the system and devices will have consistent communication to pass information when needed and when the game is over, a display will pop up on each user's device to give a report.

Through the use of a phone application, we as the designers can create the display to look exactly as we want it to. With any type of mobile application development, the programmer has full control over how the display looks. The programmer can choose color schemes, text size, location of each object on the display, etc. As the designers of this system, this is desirable because we can make our display pleasing to the users and can make the data easy to read.

5.15 Game Design

The idea behind the design of this system is to encourage cardio through people's inherent desire for competition. That desire is what will literally drive this system. After the initial boot of the system, the energy that is created by the riders will be what drives the system. The wheel will be connected to a power generator and converter, and as the riders turn the wheels, they will create energy that will be used to charge the system.

Going back to the desire of competition. Each rider will try to outdo the other and finish the race first. The faster they pedal, the more energy they will create to power the system in a shorter amount of time. With two people pedaling on the system, there should be enough power to run all the components of the system.

This game will have multiple dynamics to it to keep the riders engaged. These dynamics include riding in different "terrains", having to maintain a certain speed range, and having a power up button to change the tension on the other bike to make going the same amount of distance more difficult. The game having different terrains will basically be just a change in tension on the bike during certain parts of the race. These sections will include a flat ride (where the tension is normal), an uphill mountain ride (where the tension will be high), and a downhill coast (where the tension will be extremely low). Having these different dynamics will make the user have to ride differently and will keep them interacting with the game. Also, with the power ups, the user can decide on whether they want to use the power up right when they get it or stack multiple power ups to last longer against their foe.

The power up charge rate will have to do with distance the user has travelled and, when in the speed maintenance part of the game, will charge faster if the user is able to stay within the speed range. At the end of each session, there will be a cool down phase for each rider to allow the body to slowly get the heart rate and blood pressure back to where it should be. Cool down phases also help athletes from getting any unwanted injuries.

Below is a concept image of what the game may look like. We see several riders approaching a start line, where the game will begin. In addition to what we see on the screen, we will have a button where the players can use the power-ups that they acquire to hinder their opponent, as well as several readouts of how much power is currently being generated, what speed the player is traveling at, and how far they have traveled.

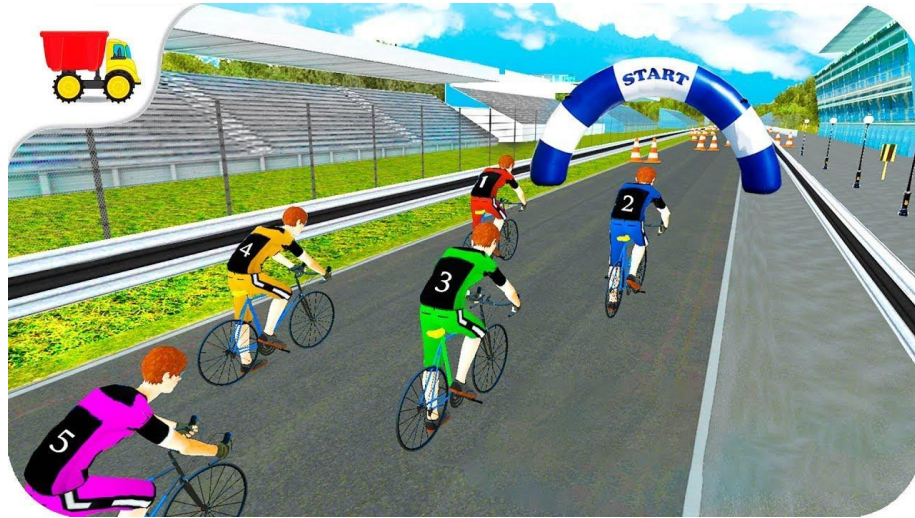

Figure 63. Game Concept

6. Integration

6.1 Board Manufacturing

Maybe the most important aspect of the Battle of the Bikes is the Printed Circuit Board (PCB). Ultimately this is the test of the teams electrical engineering prowess. The process starts on paper. The Battle of the Bikes circuitry is being designed entirely by our team, with the exception of the microcontroller. Through extensive research and the help of reference designs pulled from our preferred component manufacturers the team will design and calculate the necessary circuit schematics that will be sent to the manufacturer for creating the PCB.

The next step is to determine how many layers the PCB will require. PCB layers determine the power and the capacity of the overall board. Performance wise the more layers the better, however too many layers may be unnecessary for the purposes of the simple tasks of the Battle of the Bikes. There are multiple disadvantages to too many layers as well however. Obviously the more layers the PCB has the less cost effective it is for the project. Another disadvantage is time required to manufacture higher level boards is much greater than their lesser layer counterparts. Both time and money are huge factors for us in this project. In order to maintain a minimum number layers, while still achieving a high functioning PCB, the Battle of the Bikes power needs have to be assessed. Really the main advantage to have 4 or more layers is to separate layers by the amount of power needed for the circuit on said layer. After assessing the needs for the Battle of the Bikes, it was a decision between a 2, 4, or 6 layer board. Any more than 6 is entirely too complex for the Battle of the Bikes. The main

factor for determining the number of layers will be the different power levels needed for the components. The Battle of the Bikes, while being a fairly non-complex system will have both analog and digital signals being sent to multiple different devices that each will require different voltages from 3.3V - 12V, the limited versatility of the 2 layer is not acceptable. This leaves the 4 or 6 layer PCB design. The 6 layer stack is very similar to the 4 layer with not too different a cost. Ideally having a separate layer for the analog AGND and the digital GND, as well as the separate 3.3V, 5V and 12V needs for the different circuit designs of the AC to DC converter, DC to DC regulators, and the wireless Transmitter/Receiver. A 6 layer PCB board is preferred. Having the separate GND layers will also help with reducing the amount of noise generated and picked up by the different components on other layers.

Choosing a manufacturer for our PCB will mostly be dependent on cost and quoted time of distribution and arrival of the board.

6.2 Prototype Construction

The following image is a concept of what one of our prototypes may look like, with a few parts missing. However, this will be the initial prototype as it includes the first part that we will need to test: the generator system. As per the image, a chain is wrapped around the rear wheel of the stationary bicycle, which is also connected to a motor. This motor is then connected to a battery and battery management system which allows for power to be sent to the battery, and later rerouted to the electronics that will be placed on-board the bicycle as well as accessories that will be charged.



Figure 64. Bicycle Concept

Next, we will build the second bicycle and then add the pedal resistance system.

Finally, we will implement the microcontroller with the game integrated into it. This will be the most difficult step as we will have to connect all of the bicycle's systems to the brain of the project and make it function.

6.3 Test Plan

In order to fully test our Battle of the Bikes, we will have to first initially test all components individually, then each system individually, and finally the whole project as one unit.

The initial phase of our test plan will begin by simply testing our generators. This will allow us to find the maximum power that they can generate and how quickly our battery will be charged up. We will also be able to fix any errors that we may have made in our circuit schematics during this time due to values that had not been yet experimentally acquired. To test the generators, we will simply measure the current and voltage that they generate in order to measure the power produced.

Next, we will test our battery management circuit. This circuit must be tested after the generator is tested because the testing of the generator will give us our maximum circuit parameters. This is important because our switching voltage regulator, as well as all other circuit components, have a maximum current that may pass through them, and going over this amount will cause our circuits to fail. It is important to stress test this circuit because this is what will make or break our system - if this fails, our project will not be able to function at all. In order to test this circuit, we will connect it to the generator and measure the voltage and current across all components. We will also test it with our wall charging circuit.

Third, we must test our regulation circuit that will provide power to all of our electrical components. This will be tested third as it requires a working battery in order to be tested. This circuit is also the most crucial for all of our electronics - if this fails, none of the game components will work. The user will still be able to generate power and charge the battery, but the game will not be able to run and no metrics of the user's workout will be gathered or displayed.

Fourth, we must test all remaining components. This will include our wireless communications, microcontroller, game, resistance system, and displays and readouts.

For most of the circuit designs in the Battle of the Bikes, from the power conversion circuits, protection, battery management, and even RF circuits, they can be implemented and tested via a breadboard before construction of the

PCB is to take place to ensure valid results of the components and calculations provided by the members.

The coding aspect of the Battle of the Bikes game feature can be debugged and tested as it is being produced via the Arduino Uno and accompanying program software.

6.3.1 BLE Module Testing

When testing the HM-10 BLE module, we first check to see that it turns on when integrated into the circuit. We verify that it is on by checking to see if the LED on the HM-10 is flashing. When we establish a connection with the HM-10 via a smartphone, the flashing LED should then turn solid. If the LED begins flashing again, that is how we know connection was lost. That will be useful when testing the connection range of the module.

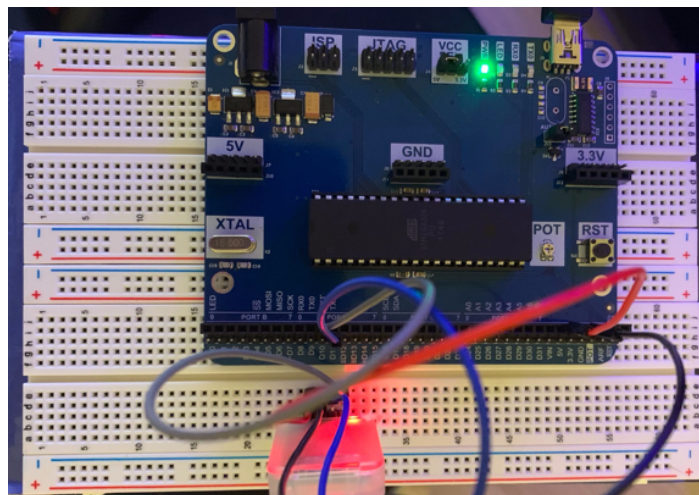

Figure 65. HM-10 Module Connection Testing

6.3.2 BLE Network Testing

BLE is what will allow the users to interact with the other user that they are battling against and will allow the system to keep each user updated as they are in mid-game. To do a test of whether our network is working, we simply found sample code online that has been verified that the code works and implemented it on our system. Then, we connected to the BLE module via a smartphone to check that we can establish a connection between the smartphone and BLE module. From there we send messages to the BLE module to ensure that the module and the smartphone are able to communicate with each other. Further testing will be conducted as we begin building our system to be sure that communication between the two devices is intact and that information is being transferred correctly.

We will also need to test the range of the BLE connection to make sure that we will have adequate connection between the devices so that we are able to communicate from the bikes to the module and back again. To do this we will connect to a application that is able to give us accurate readings on the signal strength between the devices. This test will be able to verify that we will have strong enough connections between the devices when the users are on the stationary bicycles during use of the system.

6.3.3 DC Generator Testing

Our DC generator will be used to convert the mechanical energy that is being created by the user to electricity in order to charge the battery that is powering the system. This component is very important because without it the system is limited to the life of the battery without being recharged and that would get expensive. To test the DC generator, we used an electric drill to act as a person pedaling on a bike to turn the shaft. As we applied full speed of the drill, we were able to successfully generate over 6 Volts and 1 amp of electricity. As we changed the speed of the drill, the generator also changed values accordingly; the slower the drill, the lower the output values. This test was adequate to show that our DC generator components were working as we expected and we will conduct further tests when we begin building our system to ensure that the components are still working as we want them to.

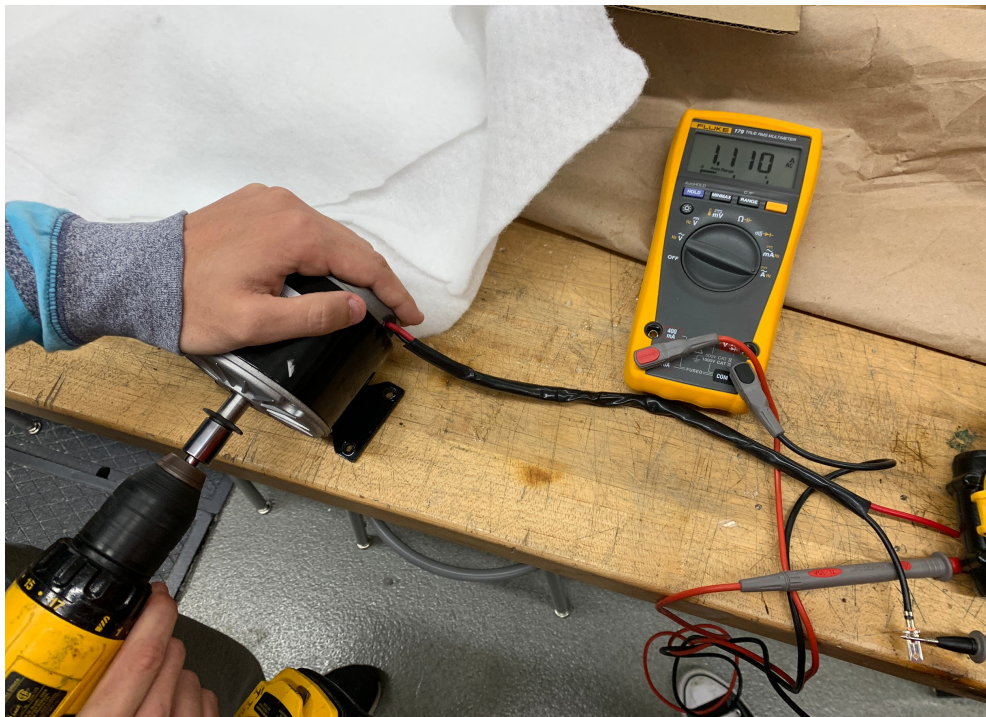

Figure 66. Amp Output of DC Generator

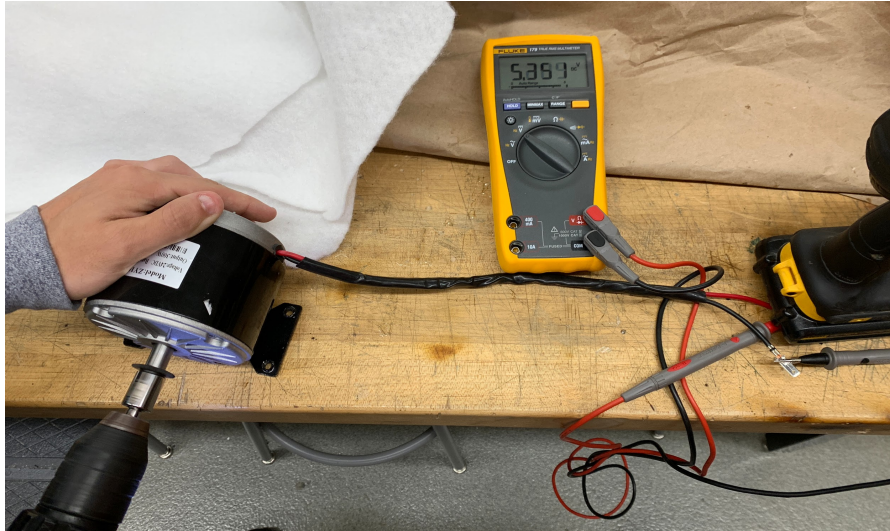

Figure 67. Voltage Output of DC Generator

6.3.4 Servos Motor Testing

Our servos will be used to change the resistance of our stationary bicycles in order to decrease the speed of the players when a power-up is used in the game. To test the servo, we connected it to the Arduino Uno that we will be using as our microcontroller. It was programmed to output a PWM signal that turned the servo fully in both ways. We then tested how much pressure the servo could withstand in order to ensure that we would not have problems when using it to change the tension of the exercise bicycle and were satisfied with the force it applied, as was expected since the servo is rated for 20kg*cm at 6.6V.

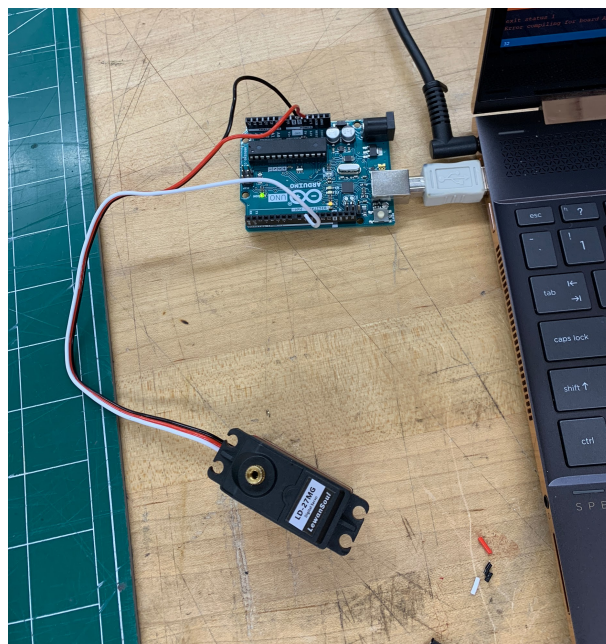

Figure 68. Testing Servo with Arduino

7. Administration

7.1 Project Schedule & Milestones

We have separated our schedule into two straight-forward parts. The first part is in Table 41 below and is for the Fall of 2018. The items in this first half of our schedule are mostly fixed and will only need to be revised with additional subtasks, which will allow us to stay on track for our final project through Senior Design 1.

Milestone	Task	Start Date	End Date	Owner
1	Brainstorm	8/29/18	9/7/18	ALL
2	Pick Top Ideas	9/7/18	9/7/18	ALL
3	Role Assignments	9/8/18	9/9/18	ALL
4	Initial Project Document – Divide and Conquer	9/9/18	9/14/18	ALL
5	Group Discussion to Finalize Project	9/18/18	9/18/18	ALL
6	Research and Documentation	9/18/18	10/8/18	ALL
7	Design PCB(s)	10/9/18	10/23/18	Brower Kovarik Leocadio
8	60 Page Draft	9/18/18	11/2/18	ALL
9	60 Page Feedback Meeting	11/6/18	11/6/18	ALL
10	Select Components	11/6/18	11/16/18	ALL
11	100 Page Submission	11/6/18	11/16/18	ALL
12	Order Components	11/16/18	12/1/18	ALL
13	120 Page Final Document	11/16/18	12/3/18	ALL

Table 41. Senior Design One Time Table

The second part of our schedule is in the Table 42. This schedule is tentative as it is dependent on when parts arrive and how long the actual testing, troubleshooting, and redesigning phases take. However, we are certain that these will take the bulk of our time during the Spring of 2019.

Milestone	Task	Start Date	End Date	Owner
15	Populate PCB(s)	1/7/19	1/14/19	ALL
16	Test & Troubleshoot Individually	1/15/19	2/3/19	ALL
17	Redesign	2/4/19	2/15/19	Brower Kovarik Leocadio
18	Retest & Troubleshoot Individually	2/16/19	2/20/19	ALL
19	Integrate System	2/21/19	3/15/19	ALL
20	Finalize Prototype	3/6/19	4/8/19	ALL
21	Peer Presentation	TBD	TBD	ALL
22	Final Report	TBD	TBD	ALL
23	Final Presentation	TBD	TBD	ALL

Table 42. Senior Design Two Time Table

7.2 Project Budget

After reviewing the desired requirements and specifications, our team decided that this project will be self-funded with each member contributing an equal one-quarter of the final amount necessary to complete it. With this in mind, we have created a table of the materials that we predict we will need for this project.

We expect that there will be some unforeseen items that we will need to include in our project during further testing and prototyping. However, we have identified all necessary major components for the project and expect that the majority of the overall cost will come from the two stationary bicycles and the power components that we have to purchase. We may also be able to find cheaper versions of current items that will further reduce the overall required budget. Keeping all of this in mind, we have come up with an initial budget of \$1000.

Item	Price	Function
Stationary Bike x2	300	Main Component
Motors x4	200	Change resistance of bikes Generate electricity from bikes
PCB x2	40	Wireless communications, project logic control
Microcontroller Board x2	60	Runs touchscreens
7" Touchscreen Display x2	120	Interface with user
SD card x2	20	Holds code for raspberry pi
Battery Charger	90	DC-DC Converter
DC-AC Inverter	90	AC power
Battery	15	Provide steady power for electronics
Mounting plates, casings	75	Clean looks
Total	1000	

Table 43. Initial Price Estimate

7.3 Project Organization

Throughout all phases of creating the Battle of the Bikes it is crucial that our team be well informed and in constant communication. For our team we did not deem it necessary to establish a Team Lead. While we considered the idea, we instead established a functioning arrangement via group communication and individual strengths and interests. By agreeing on an even peer-to-peer level of hierarchy we help keep the level of responsibility of each team member consistent and equal. In order to delegate the work for the Battle of the Bikes that needed to be done the team went over all the individual needs for the project together and each member chose a subject to cover based on their personal experience, knowledge, education, and interest.

It was obvious for Bo Williams that all software aspects and computer programming was his responsibility as he is the only Computer Engineer in the group; however, considering the rest of the team as Seniors in UCF's Electrical Engineering program have at least a background in all levels of computer programming, other members of the group will help Bo upon request.

The rest of the project involves electrical engineering specialties, which belong to Adam Brower, Nick Leocadio, and Allie Kovarik, were divided up based on personal interest in the assignment. Power conversion aspects such as the AC to DC conversion, DC generator, and the power supply (a battery) were given to

Adam Brower because of his interest and course history in power generation and power systems. Allie Kovarik has work experience in a Radio Frequency lab at Lockheed Martin and wants to continue a career with them in that depart so she accepted responsibility for the design and construction of the wireless transceiver and all calculations involved. Nick Leocadio agreed to be the teams swiss army knife so to speak. Nick took the task of DC to DC regulation, but also will be flexible in his availability to help the other members with their tasks as needed. After multiple in person, as well as remote group discussions, the team decided this was the best way to handle the workload for the project.

The following diagram illustrates each member’s main roles in the overall project.

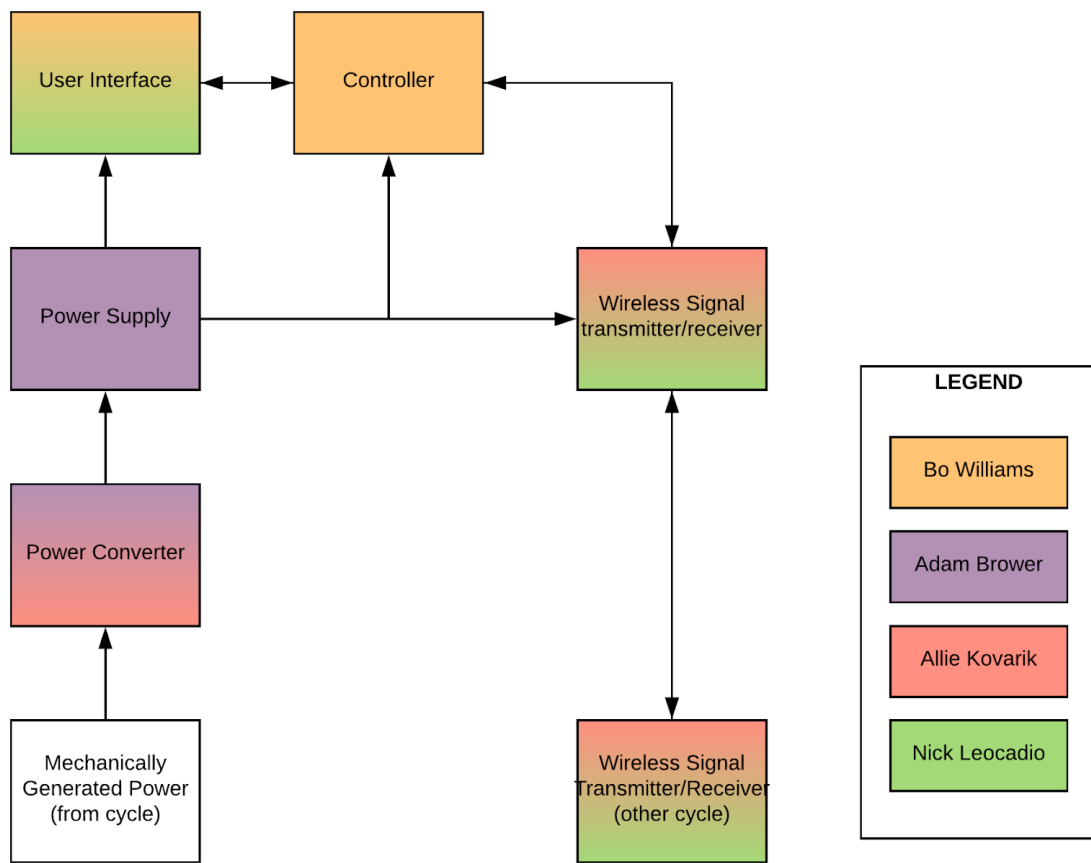

Figure 69. Roll Ownership

For our general communication and sharing of ideas we kept in contact via a messaging client known as Slack. Slack is a commonly used messaging client in many companies and offices, large or small. The Client has been tested and updated throughout the years in offices across the globe to create a very intuitive interface for all communication and project sharing needs. Every member in our team had access to the group chat as well as the ability to privately message other members in order to collaborate efficiently on all

aspects and throughout every subject of designing the Battle of the Bikes. The client also has features that easy integrate our projects documents by allowing the user to embed apps such as Google Drive, which is what our team used for created and editing all documents.

Google Drive, also known as Google Suite, is Google's version of Microsoft Office. Unlike Microsoft Office however, Google Suite is an entire online based application. With the ability to create, edit, and share all types of documents from spreadsheets, word documents, or slide presentations, Google Suite was an ideal choice for our team. Google Suites cloud-like integration allows real time editing, which allows our team to constantly over see each others progress and work done. It also provides the ability to create folders and share them with others in order to further organize each phase of the project, while keeping everything contained in a globally accessible location. Allowing multiple users to interact with the same document makes combining individual work into a final documentation convenient and simple.

8. Conclusion

The research and design stage of the Battle of the Bikes project required that several challenges be overcome in order to have a blueprint to create a final functioning project. The initial conception of the project, a competitive way for two people to work out together, quickly evolved and shaped into the final product in this document.

We expect that with all of our careful planning, the prototyping and building of the final product will flow quite smoothly. Many goals of the project were successfully achieved in the planning including the initial goal of encouraging more people to go to the gym and the design goal of fully self-powering the system. We also considered many parts of failure in our system, the main of which were thermal reasons due to the large amount of current that will be passing through our system.

All of the major components of our system were tested to ensure that they were functional and can be assembled together when the construction phase of the project begins. As a consideration for the next steps of the project, we will begin the production of our PCBs that will be used for regulating the input power that is generated from the bicycles and for communicating between the two bicycles.

When the prototyping of the bicycles begin, we will be adding a separate component to deal with excess input power and dissipate it in a way that will not damage any components by overheating them. This component must be

designed after the bicycles are acquired since we must know exactly how much current our system will be able to produce.

Finally, the actual game must be programmed and refined into our final vision. After all of the electrical components of the Battle of the Bikes system are finalized, the game will be tested. This must be done at the end because the game will rely on all of the physical components that will be placed on the bicycle, so all of them must be in place before the game's full functionality can be tested.

9. Appendices

9.1 References

- [1] *Arduino - Introduction*, www.arduino.cc/en/Guide/Introduction.
- [2] *Arduino - Introduction*,
www.arduino.cc/en/Guide/ArduinoWirelessShieldS2.
- [3] *Arduino - Introduction*, www.arduino.cc/en/Reference/CurieBLE.
- [4] *What Is a Ballista?*,
users.ece.cmu.edu/~eno/coding/CCodingStandard.html#layering.
- [5] *Arduino - Introduction*, www.arduino.cc/en/Main/ArduinoXbeeShield.
- [6] "ATmega328." *AVR Assembler -*,
www.microchip.com/wwwproducts/en/ATmega328.
- [7] "ATMEL ATMEGA SERIES." *74LS83 Datasheet*,
www.futurlec.com/ICAtmel_ATMega_Comparison.shtml.
- [8] "Burning Calories with Exercise: Calculating Estimated Energy Expenditure." *Hospital for Special Surgery*,
www.hss.edu/conditions_burning-calories-with-exercise-calculating-estimated-energy-expenditure.asp.
- [9] "Calories-and-Power - Important Lesson for All Cyclists." *TrainerRoad Blog*, 14 Sept. 2016, blog.trainerroad.com/calories-and-power/.
- [10] Dj. "Bluetooth Power Classes." *Bluetooth Power Classes: Class 1, 2 and 3*, 1 Jan. 1970, bluetoothinsight.blogspot.com/2008/01/bluetooth-power-classes.html.
- [11] Earl, Bill. "Types of Steppers." *Adafruit*, May 5, 2014.
<https://learn.adafruit.com/all-about-stepper-motors/types-of-steppers>
- [12] "Hall Effect Sensor." *ElectronicsTutorials*,
<https://www.electronics-tutorials.ws/electromagnetism/hall-effect.html>
- [13] G. Brenna, et al., "A 2-GHz carrier leakage calibrated directconversion WCDMA transmitter in 0.13- μm CMOS," *IEEE JSSC*, 39(8), pp. 1253-1262, 2004.
- [14] "Getting Started with Arduino #1." *Robomart Blog*, 10 Aug. 2015,
www.robomart.com/blog/getting-started-with-arduino-1/.
- [15] "H-Bridges - the Basics." *Modular Circuits*, 2011
<http://www.modularcircuits.com/blog/articles/h-bridge-secrets/h-bridges-the-basics/>
- [16] Hackmann, Greg. *A Summary of Network Traffic Monitoring and Analysis Techniques*, www.cse.wustl.edu/~jain/cse574-06/ftp/wpans/index.html.
- [17] "How to Convert Watts to Calories Burned While Cycling – Gear & Grit." *Gear & Grit*, 21 May 2018, gearandgrit.com/convert-watts-calories-burned-cycling/.
- [18] "Introduction to Bluetooth Low Energy." *Memory Architectures | Memories of an Arduino | Adafruit Learning System*,
learn.adafruit.com/introduction-to-bluetooth-low-energy/introduction.

- [19] J. Thomson et al., "An integrated 802.11a baseband and MAC processor," in IEEE ISSCC Dig. Tech. Papers, Feb. 2002, pp. 126–127.
- [20] McCann, Alliston T. "Okay, but how do touch screens actually work?" *ScienceLine*, Jan. 17, 2012 <https://scienceline.org/2012/01/okay-but-how-do-touch-screens-actually-work/>
- [21] Medi, Norman. "Quick Learning - How DC Motors Work." *MEEE - Mechanical Electrical Electronics Engineers* <https://meee-services.com/quick-learning-dc-motors-work/>
- [22] "Microwave Encyclopedia." *Microwaves101*, 2017, www.microwaves101.com/.
- [23] *MSP Low-Power Microcontrollers*. Texas Instruments, www.ti.com/lit/sg/slab034ad/slab034ad.pdf.
- [24] N. Ghittori, A. Vigna, P. Malcovati, S. D'Amico, and A. Baschiroto, "A low-power, low-voltage (11 mW/8.4 mW, 1.2 V) DAC+filter for multistandard (WLAN/UMTS) transmitters," in Symp. VLSI Circuits Dig. Tech. Papers, Jun. 2005, pp. 334–337.
- [25] P. van Zeijl et al., "A Bluetooth radio in 0.18 μm CMOS," *IEEE J. Solid-State Circuits*, vol.37, pp. 1679–1687, Dec. 2002.
- [26] Quinn, Elizabeth. "What All Gym Goers Should Know About MET." *Verywell Fit*, Verywellfit, www.verywellfit.com/met-the-standard-metabolic-equivalent-3120356.
- [27] R. B. Staszewski, C.-M. Hung, D. Leipold, and P. T. Balsara, "A first multigigahertz digitally controlled oscillator for wireless applications," *IEEE Trans. Microw. Theory Tech.*, vol. 51, no. 11, pp. 2154–2164, Nov. 2003.
- [28] R. Chang, et al., "A Fully Integrated RF Front-End with Independent RX/TX Matching and +20dBm Output Power for WLAN Application," *ISSCC Dig. Tech. Papers*, pp 564-565, 2007
- [29] Ray, Brian. "A Bluetooth & ZigBee Comparison For IoT Applications." *Link Labs*, www.link-labs.com/blog/bluetooth-zigbee-comparison.
- [30] RFMD, "2.4GHz 802.11b/g/n WiFi Front-End Module," RF5765 datasheet
- [31] S. S. Mehta et al., "An 802.11g WLAN SoC," *IEEE J. Solid-State Circuits*, vol. 40, no. 12, pp. 2483–2491, Dec. 2005.
- [32] "Special Comment Blocks." *Doxygen: Main Page*, www.doxygen.org/manual/docblocks.html#specialblock.
- [33] T. Macda et al., "A Low-Power Dual-Band Triple-Mode WLAN CMOS Transceiver," *IEEE JSSC*, Vol. 41(11), pp. 2481-2490, 2006.
- [34] Teng, P.L., and Wong, K.L.: 'Planar monopole folded into a compact structure for very low profile multiband mobile phone antenna', *Microw. Opt. Technol. Lett.*, 2002, 33, (1), pp. 22–25
- [35] Tyson, Jeff. "How LCDs Work." *howstuffworks*, <https://electronics.howstuffworks.com/lcd2.htm>
- [36] "What Is a Raspberry Pi?" *Opensource.com*, opensource.com/resources/raspberry-pi.
- [37] "What Is Microcontroller? - Definition from WhatIs.com." *IoT Agenda*, internetofthingsagenda.techtarget.com/definition/microcontroller.

- [38] “What Is PIC Microcontrollers? - Definition from WhatIs.com.”
WhatIs.com, whatis.techtarget.com/definition/PIC-microcontrollers.
- [39] “What’s The Difference Between DC, Servo & Stepper Motors?” Aug 25, 2013.<https://www.modmypi.com/blog/whats-the-difference-between-dc-servo-stepper-motors>
- [40] Yong Hsiang Hsieh et al., "An auto-I/Q calibrated CMOS transceiver for 802.11g,"IEEE JSSC, 40(11), pp. 2187-2192, 2005.
- [41] “Zigbee Wireless Mesh Networking.” *RF Basics - Digi International*, www.digi.com/resources/standards-and-technologies/zigbee-wireless-standard.

9.2 Copyright Permissions

CONTACT US

We appreciate your interest in Digi. Contact us here or at one of our [global offices](#)

Interest: *

Other: *

First Name: *

Last Name: *

Company: *

ADDRESS AND CONTACT INFO

877-912-3444

952-912-3444

[Chat with a Digi sales representative](#)

[Digi Smart Solutions is now SmartSense.co](#)

Speak or chat with a Digi sales representative during normal business hours (8am - 5pm CST).
Voicemail left after hours will be returned the next business day.

Global Headquarters
Digi International
11001 Bren Road East
Minnetonka, MN 55343
[Worldwide locations and phone numbers](#)

Phone: *

Email: *

Country: *

Message: *

Hello, I am currently in a class for Senior Design at the University of Central Florida and would like to know if it is okay to use the image of the Zigbee 3.0 stack protocol from your website. This diagram is being used to give further information about the Zigbee standard.

Thank you,
Bo Williams

Figure 70. Zigbee Protocol Stack Permission

support@arduino.cc

Permission for Use of Image

I am currently a student enrolled in Senior Design at the University of Central Florida and was wondering if it would be okay to use the picture of the XBee module attached to the Arduino. This picture will help illustrate the module that my group is considering using in our project.

Thank you,
Bo Williams

Figure 71. XBee Module Figure Permission

Full Name:	<input type="text" value="Bo Williams"/>
Email Address:	<input type="text" value="bwilliams480540@gmail.com"/>
Confirm E-Mail:	<input type="text" value="bwilliams480540@gmail.com"/>
Category:	<input type="text" value="Educator Inquiries"/>

Educator's FAQ Page: <https://www.adafruit.com/educators>

Adafruit offers volume discounts and special offers to educators purchasing Adafruit and Arduino products. Please contact us if you're an educator and plan to place a large order for your students/workshops. The discount can be up to an additional 10% off plus quantity discounts depending on the purchase! Email us, we have team dedicated to working with you!

We work with universities, book stores, we accept purchase orders and for large orders we can also create custom packs depending on your needs. We offer quantity discounts as well as specific discounts for educators. Please contact us to learn about our special packs, discounts and more for workshops, classes and students!

I am currently a student enrolled in Senior Design at the University of Central Florida and was wondering if it would be okay to use the images in your documentation of bluetooth low energy. These pictures will help illustrate how bluetooth actually works along with the information I used from your website as well.

Thank you,
Bo Williams

Figure 72. Permission to Use Images Describing Bluetooth

Leave a Reply

Your email address will not be published. Required fields are marked *

COMMENT

I am currently a student enrolled in Senior Design at the University of Central Florida and was wondering if it would be okay to use the pictures of the functioning of the touch screens. These pictures would help to illustrate our choice in the type of screen used in our project.

NAME *

Nicolas Leocadio

EMAIL *

nick_leo@knights.ucf.edu

Figure 73. Permission to Use Images Describing Touch Screens