

Articulated Autonomous AI-Assisted Solar Farm Grass Cutter

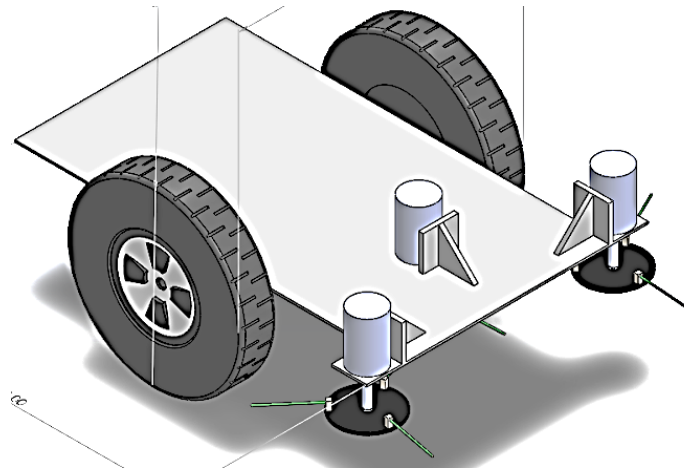

Figure Made by Mechanical Engineering Team

Department of Electrical Engineering and Computer Engineering

University of Central Florida

Dr. Lei Wei and Dr. Samuel Richie

Sponsors: OUC and Duke Energy

December 3rd, 2018

Senior Design I

Fall 2018

Group 19

Brandei Dieter
Chris Entwistle
Mario McClelland
Daniel Warner

Electrical Engineering
Electrical Engineering
Computer Engineering
Electrical Engineering

Table of Contents

Table of Figures	vii
Table of Tables	ix
1.0 Executive Summary	1
2.0 Project Description.....	2
2.1 Project Motivation.....	2
2.2 Goals.....	3
2.3 Existing Projects and Products	3
2.3.1 The Manscaper: Autonomous Lawn Mower [2]	3
2.3.2 Husqvarna Auto Mower Series [3].....	4
2.3.3 IPFW Autonomous Lawn Mower [4].....	5
2.3.4 Existing Kill Switch Systems	5
2.3.5 Existing Grass Cutting Systems	6
2.3.5.1 Standard Blades [5].....	7
2.3.5.2 Mulching Blades [5]	7
2.3.5.3 High Lift Blades [5].....	7
2.3.5.4 String-Based Grass Cutting.....	7
2.4 Engineering Specifications.....	8
2.4.1 Project Requirement Specifications.....	8
2.4.2 Technical Requirement Specifications	11
2.4.3 Engineering Market House of Quality Analysis.....	12
2.5 Possible Designs and Block Diagrams.....	13
2.5.2 Hardware Block Diagram.....	13
2.5.3 Software Block Diagram	14
3. Research and Part Selection.....	15
3.1 Relevant Technologies	15
3.1.1 Navigation Technology	15
3.1.1.1 Path Planning [6].....	15
3.1.1.2 Map Building [6].....	16
3.1.1.2.1 Lasers for Map Building	16
3.1.1.2.2 Cameras for Map Building.....	17
3.1.1.3 Self-Localization.....	18
3.1.1.3.1 Odometry [6].....	18
3.1.1.3.2 Simultaneous Localization and Mapping (SLAM) [7]	20
3.1.1.3.3 Large Scale Direct Simultaneous Localization and Mapping [7]	20

3.1.1.4 Night Vision.....	21
3.1.1.5 Computer Vision.....	21
3.1.1.6 Location and Positioning	21
3.1.1.6.1 GPS and Compass Module	22
3.1.1.6.2 Inertial Measurement Units [8]	22
3.1.2 Batteries	22
3.1.2.1 Lithium-Ion	23
3.1.2.2 Nickel Chemistry-Based	24
3.1.2.3 Lead-Acid	24
3.1.3 Battery Charge Sensors	24
3.1.4 Overall System Control	24
3.1.4.1 Microcontrollers.....	25
3.1.4.2 Processors [8].....	26
3.1.4.3 Development Boards.....	27
3.1.5 Motor Technology	29
3.1.5.1 Motor Control	29
3.1.5.1.1 H-Bridge PWM Driver ICs [9]	29
3.1.5.1.2 Dual, Full-Bridge PWM Motor Driver ICs [11]	30
3.1.5.1.3 Motor Encoders [12] [13]	30
3.1.5.2 Types of DC Motors	30
3.1.5.2.1 DC Brush Motors [14]	31
3.1.5.2.2 DC Brushless Motors [15]	32
3.1.6 Voltage Regulators	32
3.1.6.1 Linear Voltage Regulators [16]	33
3.1.6.2 Standard (NPN) Regulators [17].....	34
3.1.6.3 Low Dropout (LDO) Regulators [18]	34
3.1.6.4 Step-Down Converters [19]	34
3.1.7 Switches Technology.....	35
3.1.7.1 Toggle Switches [22]	35
3.1.7.2 Pushbutton Switches [21]	36
3.1.7.3 Selector Switches [23]	36
3.1.7.4 Speed Switches [24].....	36
3.1.7.5 Diode Switches	36
3.1.8 Programming	37
3.1.8.1 C Programming Language [26]	38

3.1.8.2 Python Programming Language [26].....	38
3.1.8.3 C++ Programming Language [26].....	39
3.1.8.4 OpenCV [27] [28].....	39
3.1.9 Obstacle Avoidance Sensors	40
3.1.9.1 Ultrasonic Sonar Sensors	40
3.1.9.2 Lidar Sensors	40
3.1.9.3 Infrared Sensors	41
3.1.10 Operating Systems	41
3.1.11 Perimeter Boundary Wire [29]	41
3.1.12 Wireless Communications [30]	43
3.1.12.1 Wi-Fi™ [30] [31].....	43
3.1.12.2 Bluetooth [30]	44
3.1.13 I ² C Protocols [32]	44
3.1.13 SPI Protocols [33].....	45
3.1.14 UART [34].....	46
3.2 Strategic Components and Part Selections.....	46
3.2.1 Development Boards Selection	49
3.2.1.1 Raspberry Pi Model 3 B [35]	50
3.2.1.2 Arduino Mega 2560 [37] [38].....	51
3.2.2 Microcontrollers Selection	51
3.2.2.1 ATmega2560 [39].....	52
3.2.2.2 ATmega16U2 [40] [41]	53
3.2.3 Perimeter Boundary Wire Selection	54
3.2.3.1 Automower Boundary Wire [42].....	54
3.2.3.2 Extreme Dog Fence Wire [43].....	55
3.2.4 Timer for Perimeter Generator Circuit Selection	55
3.2.4.1 NE555P Timer [44].....	56
3.2.4.2 CD4541B Timer [45].....	56
3.2.5 Operational Amplifier for Perimeter Receiver Circuit.....	56
3.2.5.1 LM324N Operational Amplifier [46]	57
3.2.5.1 LF351 Operational Amplifier [47].....	58
3.2.6 Camera Selection.....	58
3.2.6.1 Raspberry Pi 3 Model B Camera Fisheye [48]	58
3.2.6.2 Raspberry Pi Camera Module V2 [49]	59

3.2.7 Obstacle Avoidance Sensors Selection.....	59
3.2.7.1 HC-SR04 Ultrasonic Ranging Module [50]	60
3.2.7.2 PING by Parallax [51]	61
3.2.7.3 Arduino Infrared Collision Avoidance Module [52]	61
3.2.8 Battery Charge Sensors Selection.....	61
3.2.8.1 MAX17043 Fuel Gauge Power Management Board [53]	62
3.2.8.2 BQ27441-G1 System-Side Impedance Track Fuel Gauge [54]	62
3.2.9 Digital Compass and GPS Module Selection	62
3.2.9.1 Holybro Micro M8N GPS Module	63
3.2.9.2 RadioLink SE100 GPS Module.....	64
3.2.10 Wireless Chip Selection.....	64
3.2.10.1 USB Wi-Fi (802.11b/g/n) Module with Antenna for Raspberry Pi [56] .	65
3.2.10.2 GP-Xtreme Mini Compact USB 2.0 N [55].....	65
3.2.11 Motor Driver Chip Selection	65
3.2.11.1 L293DNE Motor Driver Chip [58]	66
3.2.11.2 DRV8842 DC Motor Driver IC [57]	67
3.2.12 Wheel DC Motors Selection.....	67
3.2.12.1 DC 12V 180RPM Geared Motor [59]	67
3.2.12.2 Cytron 12V Spur Gear Motor [60].....	68
3.2.13 String-Based Blades DC Motors Selection	68
3.2.13.1 Machifit 895 DC Gear Motor [61].....	68
3.2.13.2 RS-775 DC Gear Motor [62]	69
3.2.14 Voltage Regulators Selection	69
3.2.14.1 LM2596S-ADJ Step-Down Voltage Regulator [63]	70
3.2.14.2 LM2673S-ADI Step-Down Voltage Regulator [64].....	70
3.2.15 DC Motors Battery Selection	70
3.2.15.1 DMD 160Ah/12V Li-polymer Battery [65].....	71
3.2.15.2 DMD BMS 100Ah/12V Dry Cell Lithium Ion Battery [66]	71
3.2.15.3 DMD 100AH/12V Lithium Ion Battery [67].....	71
3.2.16 Electrical Components Battery Selection	72
3.2.16.1 Shenzhen 20Ah/12V Lithium Polymer Battery [68]	73
3.2.16.2 Yinkai Power 20Ah/12V Lithium Ion Battery [69].....	73
3.2.17 Perimeter Wire Battery Selection	73
3.2.17.1 DTP 10Ah/12V Lithium Polymer Battery [70]	74

3.2.17.2 Great Max 10Ah/12V Lithium Polymer Battery [71].....	74
3.2.1 Front Wheels Selection.....	75
3.2.2 Caster Wheels Selection	75
3.2.4 String-Based Blades and Trimmer Head Selection	76
4.0 Related Standards and Design Constraints	77
4.1 ABET Design Constraints.....	77
4.1.1 Time Constraints.....	77
4.1.2 Economic Constraints.....	77
4.1.3 Environmental Constraints	78
4.1.4 Weight Constraints	78
4.1.5 Size Constraints	79
4.1.6 Ethical Constraints.....	79
4.1.7 Health and Safety Constraints	80
4.1.8 Manufacturability Constraints	81
4.1.9 Power Constraints.....	82
4.2 Standards	83
4.2.1 IEEE Standards.....	83
4.2.1.1 Battery Standards [74] [75].....	84
4.2.1.2 C Language Standards [76].....	84
4.2.1.3 Wireless Standards.....	84
4.2.1.4 Software and Systems Engineering- Software Testing.....	85
4.2.1.5 Robot Map Data Representation for Navigation Standard [82].....	86
4.2.2 Robotics Standards [83].....	87
4.2.3 Inter-Integrated Circuit (I2C) Standards.....	88
4.2.4 Universal Serial Bus (USB) Standards.....	88
4.2.5 Electromagnetic Compatibility (EMC) Standards.....	89
4.2.6 Institute for Printed Circuits (IPC) PCB Standards	91
5.0 Overall Integration, PCB Design and System Testing.....	92
5.1 Hardware Design.....	92
5.1.1 Initial Design Architectures and Related Diagrams	92
5.1.2 Sensors Subsystem 1	93
5.1.3 Location and Positioning Subsystem.....	93
5.1.4 Control Subsystem 1.....	94
5.1.5 Control Subsystem 2.....	94

5.1.6 Sensors Subsystem 2	95
5.1.7 Power Subsystem 1.....	95
5.1.8 Power Subsystem 2.....	95
5.1.9 Boundary Subsystem 1	98
5.1.10 Drive Subsystem.....	98
5.1.11 Wireless Communications Subsystem.....	99
5.1.12 Laptop Application Subsystem.....	100
5.1.13 Camera Subsystem	100
5.1.14 Boundary Subsystem 2.....	100
5.1.15 Power Subsystem 3.....	100
5.2 Project Software Design Details	101
5.2.1 Overall Software Functionality	101
5.2.1.1 Ultrasonic Sensor and Obstacle Avoidance.....	102
5.2.1.2 Camera and Obstacle Detection.....	103
5.2.1.3 Perimeter Wire System Software Design	104
5.2.1.4 GPS Module with Compass.....	105
5.2.1.5 Motor Control System.....	105
6.0 Project Testing and Prototype Design.....	106
6.1.1 Prototype Design	107
6.1.1.1 Grass Cutter System Circuit Schematic.....	107
6.1.1.2 Perimeter Wire Generator Circuit Schematic	108
6.1.1.3 Perimeter Wire Generator Circuit PCB	108
6.3 Testing.....	109
6.3.1 Motor Control Breadboard Testing	110
6.3.2 Ultrasonic Breadboard Testing.....	110
6.3.3 Perimeter Boundary System Breadboard Testing	111
6.3.4 Camera Raspberry Pi Testing.....	112
6.3.5 Location and Positioning Breadboard Testing	113
7.0 Administrative Content.....	114
7.1 Fall 2018 Senior Design I Milestones.....	114
7.2 Spring 2019 Senior Design II Milestones	115
7.2 PCB Vendor [96].....	116
7.3 Budget and Financing.....	118
8.0 Conclusion	120

8.1 Project Roles	120
8.2 Potential Project Design Issues	121
8.2.1 Navigation through Uneven Terrain.....	121
8.2.2 Charge Regulator Limitations	122
8.2.3 GPS and Digital Compass Limitations.....	122
8.2.4 Navigation and Object Avoidance.....	122
8.2.5 String-Based Blade Limitations.....	123
8.3 Future Goals	123
8.3.1 Solar Panel Charging Station.....	123
8.3.2 Solar Panel on Grass Cutter.....	123
8.3.3 Computer Vision for Field Mapping	124
8.3.4 Metal Blades for Durability	124
8.3.5 Weather Sensor Sheltering Application	124
8.4 Conclusion.....	125
A-Appendices	I
A1- Copyright Permissions	I
A2- Datasheets	V
A3- References.....	VII

Table of Figures

Figure 1: House of Quality Trade-Off Table made by Christopher Entwistle	12
Figure 2: Possible Hardware Block Diagram for the Grass Cutter System made by Brandei Dieter.....	13
Figure 3: Possible Hardware Block Diagram for Boundary System made by Brandei Dieter	14
Figure 4: Possible Software Block Diagram made by Brandei Dieter	14
Figure 5: Path Planning Diagram around PV Structures made by Brandei Dieter	15
Figure 6: Laser Map Building made by Brandei Dieter	17
Figure 7: Camera Map Building made by Brandei Dieter	17
Figure 8: Borenstein’s Model Diagram on Grass Cutter Model made by Brandei Dieter	19
Figure 9: Overview of How LSD-SLAM Works used with reference from medium.com [7]	21
Figure 10: Brush DC Motors Diagram used with reference from Allegro Micro Systems [14].....	31
Figure 11: Brushless Motors Diagram used with reference from electricaltechnology.com [15].....	32
Figure 12: Canny Edge Detection Process.....	39
Figure 13: Boundary System Diagram used with Permission from Robotshop.com [29]	42
Figure 14: I ² C Bus Configuration made by Mario McClelland.....	45

Figure 15: Bit fields of data transmission on an I ² C Bus made by Mario Mcclelland	45
Figure 16: Raspberry Pi Model 3 B used with permission from Adafruit.com [36]	51
Figure 17: Arduino Mega picture taken by Brandei Dieter	51
Figure 18: Atmega2560 Microcontroller picture taken by Brandei Dieter.....	53
Figure 19: ATmega16U2 used with reference from Microchip.com [41].....	53
Figure 20: Perimeter Boundary Wire used with permission from Amazon.com [42].....	54
Figure 21: NE555P Timer picture taken by Brandei Dieter	56
Figure 22: LM324N Operational Amplifier picture taken by Brandei Dieter	57
Figure 23: Raspberry Pi 3 Model B Night Vision Camera picture taken by Brandei Dieter	59
Figure 24: HC-SR04 Ultrasonic Sensor picture taken by Brandei Dieter	60
Figure 25: MAX17043 Fuel Gauge Power Management Board picture taken by Brandei Dieter.....	62
Figure 26: Holybro Micro M8N GPS Module picture taken by Brandei Dieter	63
Figure 27: USB Wi-Fi Module with Antenna used with permission from Adafruit.com	65
Figure 28: L293DNE Motor Driver picture taken by Brandei Dieter	66
Figure 29: DC 12V 180 RPM Geared Motor used with permission from Banggood.com	67
Figure 30: 895 DC Gear Motor used with permission from Banggood.com [61].....	69
Figure 31: LM2673S-ADJ Step-Down Voltage Regulator used with permission from Texas Instruments.....	70
Figure 32: DMD 100Ah/12V Lithium Ion Battery used with permission from Alibaba.com [67].....	72
Figure 33: Yinkai Power 20Ah/12V Lithium Ion Battery used with permission from Alibaba.com.....	73
Figure 34: Great Max 10Ah/12V Li-Po Battery used with permission from Alibaba.com [71].....	74
Figure 35: Flow of PCB Design and Implementation made by Christopher Entwistle....	91
Figure 36: Updated Hardware Block Diagram of the Grass Cutter System made by Brandei Dieter.....	92
Figure 37: Updated Hardware Block Diagram of the Boundary System made by Brandei Dieter.....	93
Figure 38: Sensors Subsystem 1 Design made by Brandei Dieter.....	93
Figure 39: Location and Positioning Subsystem Diagram made by Brandei Dieter	94
Figure 40: Control Subsystem 2 Camera Diagram made by Brandei Dieter.....	94
Figure 41: Battery Charge Sensor Diagram made by Brandei Dieter	95
Figure 42: LM2673 Circuit Design from TI Webench Power Design Simulator.....	96
Figure 43: Efficiency Versus Output Current Plot from TI Webench Power Design Simulator.....	96
Figure 44: Load Transient Plot from TI Webench Power Design Simulator	97
Figure 45: Bode Plot from TI Webench Power Design Simulator	97
Figure 46: Drive Subsystem Flowchart made by Brandei Dieter	98
Figure 47: Drive Subsystem Diagram made by Brandei Dieter	99
Figure 48: Wireless Communications Diagram made by Brandei Dieter	99
Figure 49: Subsystem Features and Software Design Space made by Mario Mcclelland	101

Figure 50: Initial Start Up flow chart made by Mario Mcclelland	102
Figure 51: Sample Code for Sensors made by Mario Mcclelland	102
Figure 52: Microcontroller to Ultrasonic Sensor Communications Diagram made by Mario Mcclelland.....	103
Figure 53: Microcontroller to Camera Communications Diagram made by Mario Mcclelland.....	103
Figure 54: Camera Software Flowchart made by Mario Mcclelland	104
Figure 55: Sample Code for Perimeter Wire System made by Mario Mcclelland	104
Figure 56: Sample Code for GPS Module made by Mario Mcclelland.....	105
Figure 57: Grass Cutter System Circuit Schematic made by Brandei Dieter	107
Figure 58: Perimeter Wire Generator Circuit Schematic made by Brandei Dieter	108
Figure 59: Perimeter Wire Generator Circuit PCB made by Brandei Dieter	108
Figure 60: Motor Driver Chip and DC Motors Tested picture taken by Brandei Dieter	110
Figure 61: Ultrasonic Sensors Tested picture taken by Brandei Dieter	110
Figure 62: Ultrasonic Sensors Accuracy Tested picture taken by Brandei Dieter	111
Figure 63: Perimeter Boundary System Tested picture taken by Brandei Dieter.....	111
Figure 64: Perimeter Boundary System Functionality Tested picture taken by Brandei Dieter.....	112
Figure 65: Camera Tested picture taken by Brandei Dieter	112
Figure 66: GPS Tested picture taken by Mario McClelland.....	113
Figure 67: Standard Example GPS Output by Mario McClelland	113
Figure 68: Pololu Permission Request.....	I
Figure 69: Adafruit Permission Request Approved.....	II
Figure 70: AliExpress Permission Request.....	II
Figure 71: Amazon Permission Request.....	III
Figure 72: Digikey Permission Request	III
Figure 73: Robotshop Permission Request Approved.....	IV
Figure 74: Permission Request	IV

Table of Tables

Table 1: Grass Cutting Systems Comparison	7
Table 2: Overall Requirement Specifications (ORS).....	9
Table 3: Billing Requirement Specifications (BRS).....	9
Table 4: Project Requirement Specifications (PRS).....	10
Table 5: Technical Requirement Specifications	11
Table 6: Technologies used for Map Building	16
Table 7: Self-Localization Technologies	18
Table 8: Odometry Equations [6]	18
Table 9: Borenstein’s Method Equations [6].....	19
Table 10: Location and Positioning Technologies.....	22
Table 11: Battery Type Comparison.....	23
Table 12: Processors Comparison.....	27
Table 13: DC Motor Types Comparison	31
Table 14: Voltage Regulators Comparison.....	32
Table 15: Switches Technology Comparison	35
Table 16: Programming Languages and Libraries Comparison	38

Table 17: Wi-Fi™ versions suitable for autonomous grass cutter [31].....	43
Table 18: Wireless Communications Comparison [30].....	44
Table 19: Microcontrollers and Development Boards Parts Selection Overview	46
Table 20: Boundary System Parts Selection Overview	47
Table 21: Sensors and Location Parts Selection Overview	47
Table 22: Navigation and Drive Parts Selection Overview	47
Table 23: Power System Part Selection Overview	48
Table 24: Mechanical Part Selection Overview.....	48
Table 25: PCB Components Part Selection Overview	49
Table 26: Development Boards Selection.....	50
Table 27: Microcontrollers Selection.....	52
Table 28: Perimeter Boundary Wire Selection	54
Table 29: Timer for the Boundary System Selection.....	55
Table 30: Perimeter Wire Receiver Operational Amplifier Selection	57
Table 31: Camera Selection	58
Table 32: Obstacle Avoidance Sensors Selection.....	60
Table 33: Battery Charge Sensors Selection.....	61
Table 34: Digital Compass and GPS Module Selection	63
Table 35: Wireless Chip Selection.....	64
Table 36: Motor Driver Chip Selection	66
Table 37: Wheel DC Motors Selection.....	67
Table 38: String-Based Blades DC Motors Selection.....	68
Table 39: Voltage Regulators Selection	69
Table 40: DC Motors Battery Selection.....	71
Table 41: Electrical Components Battery Selection	72
Table 42: Perimeter Wire Battery Selection	74
Table 43: Wheel Selection from Mechanical Team	75
Table 44: Caster Wheel Selection by Mechanical Team	76
Table 45: String Trimmer Head Selection by Mechanical Team	76
Table 46: ISO/IEC/IEEE 29119 Standards.....	86
Table 47: ISO/TC 299 Robotic Standards	88
Table 48:International Electrotechnical Commission 62680 Universal Serial Bus Standards Suite	89
Table 49: Applicable EMC Standards	90
Table 50: Motors Power Specifications Table.....	95
Table 51: Perimeter Wire Specifications Table	100
Table 52: Parts Ordered and Received for Testing.....	106
Table 53: Overall Testing Results.....	109
Table 54: Fall 2018 Senior Design I Milestones Table	114
Table 55: Spring 2019 Senior Design II Milestones Table.....	115
Table 56: Prices and Specifications of PCBs from JLCPCB.com [96]	116
Table 57: Shipping Details from JLCPCB.com [97]	116
Table 58: PCB Capabilities from JLCPCB.com [98]	117
Table 59: Project Budget and Financing Table1.....	118
Table 60: Project Budget and Financing Table2.....	119
Table 61: Team Member’s Project Roles	120

Table 62: Datasheets	V
Table 63: Datasheets	VI

1.0 Executive Summary

Traditionally, gas powered lawn mowers pose an environmental threat. As Solar Farms become more popular, the use of traditional lawn mowers to maintain the local vegetation has become a focus. According to Duke Energy and Orlando Utility Commission, maintaining the vegetation growth of the Solar Farms costs roughly \$150,000 to \$200,000 per 500 acres per year. To lower the maintenance costs, they are requesting designs and prototypes of an Articulated Autonomous AI-Assisted Solar Farm Grass Cutter. The purpose is to design a solution for them to lower the costs of maintenance and manpower for solar farm vegetation control, while also creating less of a carbon footprint compared to traditional solutions. The solar farm grass cutter is sponsored by Duke Energy and Orlando Utility Commission with a \$1,500 budget. It will be developed in conjunction with interdisciplinary teams consisting of Computer Science, Electrical Engineering, Computer Engineering, and Mechanical Engineering students. After the final product is designed, implemented and built, a competition between University of Central Florida and University of South Florida teams will have the chance in competing against each other. This will be judged on the overall design, elements, precision, accuracy and capabilities.

Three teams will work together with various different tasks and roles. The focus of the Electrical and Computer Engineering team will be on the hardware, software, power systems, electrical designs and implementations of the overall grass cutter system. This includes specifications for the components, the design and implementation of the hardware and software and the integration of components to create a fully functional prototype that meets all the engineering standards and requirements. The focus of the Mechanical Engineering team will be on the framework, wheels, string-based blade, motion and size of robot design and implementations. The focus of the Computer Science team will be on the Laptop application for the robot, computer vision, path planning, image processing, mapping, self-localization and communication to the electrical designs.

The documentation identifies and explains the motivation, goals, related work, engineering specifications and block diagrams. Technical requirements by the sponsors, Duke Energy and Orlando Utility Commission, are identified within this documentation. An Engineering Market House of Quality Analysis Table is generated to identify and compare the sponsor's requirements to the technical requirements to show positive and negative correlations between them. Extensive research on existing products/projects, relevant components and technologies, and applicable tradeoffs were used to design a functioning autonomous grass cutter. The research will provide resources from which the rest of the design can be influenced upon. Applicable design constraints and engineering standards will be enforced. Selected components will be identified along with an explanation of choice and comparison to other candidate parts. A series of components breadboard testing will ensure the functionality of each component and design. This will be conducted before the assembly of an overall prototype. The breadboard testing will follow guidelines based on research, standards, design constraints and specific requirements to assure functionality.

2.0 Project Description

This section provides background information to provide a scope of what this project is going to be designed upon. The following sub-chapters include information on the project motivation, goals, existing projects and products, engineering specifications, possible designs and block diagrams.

2.1 Project Motivation

Solar farms are built upon concrete or grass terrains but most solar farms that exist today are built on top of grass terrains. Although the sun could be considered a free source of energy, solar energy solutions are far from it. One of the biggest costs that are factored in when an energy company considers a solar farm is the cost of the farm itself. By creating a more cost-effective solution, it is possible that more energy companies will take on the mission of using alternative and renewable energy sources in lieu of today's fossil fuel powered society.

The approach to a more cost-effective solution is to use engineering practices to integrate modern technology into today's traditional lawn mowing process and to ultimately create an autonomous lawn mower. When it comes to comparing current solutions, there is a monetary gap. Autonomous lawn care solutions from well-known lawn care brand, such as John Deere and Husqvarna, start from about \$1500 to \$2500 USD for robots that are not capable of maintaining half an acre. Using the figures from Duke Energy and Orlando Utility Commission's estimate for solar farm maintenance, the solution would need to be between \$300 to \$400 USD per acre.

There are numerous factors on whether the project or even current products will be implemented as a solution. One factor is cost. Robotic solutions come with an upfront cost. The best way to beat the current solution is to build a robot that is maintenance free with a long lifespan. Another factor is coverage. To have a cost-effective solution, a coverage area greater than the current competitors, that range around \$5000 to \$6000 per acre. It would not be financially ideal to come up with a solution that needs over a decade of zero maintenance to break the cost difference of just contracting the solar farm lawn maintenance. The solution must have the least amount of points of failure possible.

This project could possibly lay the foundation of what could be an entire industry or even societal shift away from nonrenewable energies. In an article written August 6th, 2018, by Yasemine Saplakoglu on livescience.com, it is estimated that a roughly 2-degree Celsius rise in global temperature could cause Earth to enter a "Hot House" state. The article defines a "Hot House" state as a point in which "natural feedback systems that currently keep the Earth cool will unravel." While it is unlikely that just solving a labor-intensive problem for an energy company would begin an industry or societal shift towards alternative energy, this project could be one of the many approaches towards encouraging implementation of renewable energy [1].

2.2 Goals

The goals of this project are to design and implement a power efficient, functional and prestige Autonomous AI-Assisted Solar Farm Grass Cutter. The main goal is to cut the grass areas under, around and below the Solar PV Structures without damaging or having any contact with the structures, humans, obstacles and/or objects that might be in the way. The Grass Cutter should stay in the boundaries of the set areas and cut the grass in an efficient matter in a reasonable time frame.

2.3 Existing Projects and Products

This section displays similar finished projects or products that have similar technologies that may be used in this project. These projects or products showcase an autonomous grass cutting solution. While it is possible that there is already a finished product or project that already fits within the design constraints, it is unlikely. The goals while researching was to pull specific ideas or approaches to the design constraints that would be useful to implement or use while designing for this project.

2.3.1 The Manscaper: Autonomous Lawn Mower [2]

The first project, “The Manscaper: Autonomous Lawn Mower” was a University of Central Florida senior design project. The Manscaper was developed by UCF students Andrew Cochrum, Joseph Corteo, Jason Oppel, and Matthew Seth. The Manscaper utilizes a commercial blade system (the blade system of a commercial lawn mower) with custom built charging and navigation systems appended to the commercial blade system. It uses a combination of software and components to maintain the grass, maintain the product itself, and to safely operate within a desired area.

The battery of choice for The Manscaper was 2 lead acid batteries. Their two-battery system was able to power their device for an hour per full charge but had a recharge time of 3 hours. While their own requirements were met, this project needs to have a lower recharge time. Weight is a design constraint for this project. This project’s two lead-acid batteries only provided an hour’s worth of power. It is not an ideal case for this project’s design. Though the Manscaper’s battery choice is not ideal for this project, the charging system of their project is worth analyzing. The Manscaper utilized a battery monitoring system. The battery monitor module is manufactured by Texas Instruments and is Part No. BQ34Z110. This battery monitor is accurate up to 95% and provides up to 5 output pins for LEDS to display battery life. This component was shown to have a simple implementation process and intuitive integration.

Components used in the implementation of The Manscaper included a microcontroller, ultrasonic sensors and rubber bumpers. It utilized a high mounted camera to map the area of choice and marked the boundaries or points of interest (POI) using Computer Vision (CV) Technology. The software algorithms can control the navigation of the device through series of obstacles with a combination of its ultrasonic distance sensors, camera,

and rubber bumpers. The software utilized the camera to map the layout of an area and mark boundaries, like the perimeter fence.

2.3.2 Husqvarna Auto Mower Series [3]

A variety of commercial products were researched to influence the design of this project. Some interesting devices were the Auto mower line from Husqvarna. Husqvarna's Auto mower line is a series of different autonomous lawn mowers. Their products range from \$1,500 USD MSRP to \$3,500 USD MSRP. They have a cutting range of 0.25 to 1.25 acres respectively. This project's ceiling cost is \$1,500.00 USD. The Auto mower 310 is analyzed due to the ideal budget range for this project. Although analysis of Husqvarna's Auto mower line was limited due to lack of information on their website, it did provide lists of capabilities, specifications and form factors pertaining to their Auto mower products.

Looking at a comparison of Husqvarna's Auto mower line of products, it appears that form factor and physical aspects were prioritized over electrical capabilities in terms of what your money buys. For example, Husqvarna's budget option, the Auto mower 310, provides almost no capabilities that the customer requires. On the other hand, Husqvarna's top-tier Auto mower product, the Auto mower 450X, fulfills all the customer's requirements along with providing extra capabilities. While it makes sense that physical constraints are met first, i.e., the autonomous mower must autonomously cut grass, it was both disappointing and inspiring to see that the autonomous mower we design could possibly be a comparable to a \$3,500 USD product. Drawing from Husqvarna's pricing approach, we decided that it would make sense to allocate most of the funding to the mechanical engineering team less the battery we choose. Allocating more funds to the mechanical engineering team means that the grass cutter will be more robust. It is also possible to integrate the better physical components into the field of electrical and computer engineering that could include bumpers that send signals to a microcontroller. This means that an extra focus is needed on cost effectiveness when it comes to selecting the components. Examination on Husqvarna's pricing comparison is that the lower priced models come with a "guide wire" for a perimeter while the higher priced models come with a settable perimeter within the Auto mower's software. Considering that a price difference decides between whether a physical perimeter wire is required or is built into the software, the consideration of the budget will decide which system to use.

Another examination of the cost comparisons between Husqvarna's Auto mower models showed that the higher priced models have a patented GPS assisted navigation. In a discussion on GPS navigation with the other interdisciplinary teams designing this project of the grass cutter, the GPS assisted navigation was a possible design to implement into the grass cutter. Coordinated with the Electrical and Computer Engineering, and Computer Science Team led to the decision of using a GPS assisted navigation by using an Inertial Measurements Unit to track its position, speed and location. The Inertial Measurements Unit has an onboard gyroscope, accelerometer and GPS capabilities. The technical requirements of this project include the use of a secondary power system to last after the

main power system drained, to ping the location of the grass cutter to the laptop application. This will

allow the users to find the grass cutter using the location pinged to the application and send someone to go find and charge the grass cutter's batteries. This system will be designed, implemented and tested by the Computer Science, Electrical and Computer Engineering Teams.

2.3.3 IPFW Autonomous Lawn Mower [4]

The last project, "Autonomous Lawn Mower" was a senior design project. This senior design project, at Indiana University – Purdue University – Fort Wayne, was developed by IPFW students consisting of a three-person electrical and computer engineering (ECE) team and a three-person mechanical engineering (ME) team. The IPFW students used a lawn mower deck from a commercially available lawn mower (Craftsman Professional 88776) and had their Mechanical Engineering team design and fabricate a frame along with necessary components for a rear wheel drive system.

The IPFW "Autonomous Lawn Mower" used a shaft encoder and digital compass for primary navigation. Their drivetrain was created using a commercial wheelchair's set of wheels and motors, a design constraint was created of a minimum voltage requirement of 24 volts. To fulfill the previously mentioned design requirement, along with their requirement of time per charge, the IPFW team utilized a pair of 12-volt lead-acid batteries, connected in series. The lead-acid batteries are energy dense, their choice of power storage fulfilled design constraint and requirements, allowing them 768-watt hours of power or 1.6 hours of run time for their configuration.

Although the IPFW team used an off the shelf development board as their main microcontroller system, lessons can be learned through a flowchart provided on their project documentation. The IPFW team explains in detail the overall thought process of the steps the microcontroller goes through, as the lawn is getting cut. This system process may be suitable for their project, but this project of the grass is planned to be more intelligent than the IPFW Autonomous Lawn Mower. The thought process previously mentioned is nowhere near robust enough for the goals and requirements of this project but provides an excellent foundation on how to program a logical flow onto the processor that will be selected.

2.3.4 Existing Kill Switch Systems

The Manscaper mower project influenced a kill switch to be activated in the design of the autonomous grass cutter if the mower needs to be shut off immediately. Sensors and computer vision will indicate whether the machine is moving towards an obstacle; the obstacle should be avoided. In the case that the mower does not avoid the obstacle in time, or while turning, collides into a different obstacle, the Manscaper project incorporated a switch under the bumper of the machine. The bumper was pushed outward using a spring load and when pushed inward while experiencing a collision, a switch would be activated

to send a signal to the microcontroller. The signal shuts off the cutting mechanism to prevent any injury to the obstacle or the machine.

The Auto mower products manufactured by Husqvarna implemented kill switching techniques in an alternative manner. The suspension system underneath the mowers within the commercial line of Auto mower products stop operation of blade motors when the machine is lifted or turned over. The process is executed by notifying the control system when weight is lifted off the wheels. In the worst-case scenario of the Auto mower tipping over, the same signal processing design cuts off the machine. An accelerometer can be used for this type of shut-off signal as well. This is an efficient approach for initiating the kill switch signal because the same input takes care of two faulty mishaps that may occur while the machine is in operation. A remote kill switch must shut off the dc motor that operates the string blades from a 50-foot distance as a requirement in this project. The signal can be sent to a location port on the microprocessor that is designated for shorting out motors. The DC motor controlling the string cutter will cut off as well. In exploration of the options to shut down one to all three motors, the safest option would be to shut down all three motors. Nonetheless, the disconnection of all three motors simultaneously may result in more circuitry and components on a limited processor. Therefore, killing the battery alone will make for a simpler task. A reason for not wanting to kill the entire battery would be to keep the software running on the machine while the motionless mower awaits a resume signal. Startup time would also be saved from the amount of times the system needs rebooted.

The overall goal for design regarding a kill switch is safety. Safety needs prioritized over efficiency and complexity, yet these other factors must be considered if the final product will be valued in comparison to the already manufactured autonomous mowing machines. Single options of kill switches being initiated to cease operation of motors or entire battery have been discussed regarding the wireless transmitted signal that is managed manually. Maintaining a designated control port for this kill switching purpose for the incoming wireless signal is a must in the design. Different motors can also be cut-off for protection using the obstacle avoidance system as well as the kill switch signal that is wirelessly processed from an observer. If the use of manual shut-off for an emergency or ‘done for the day’ type of kill-switch is used, then shutting off the entire battery or electrical system would be a good option for safety purposes. The other options for motor control signals can be produced by the navigating sensor system while maintaining safety as the highest priority.

2.3.5 Existing Grass Cutting Systems

Since the intent of the project is to create an autonomous grass cutter, research into the way the autonomous grass cutter physically cuts the grass is of great importance. Depending on application, there are different styles of blade when it comes to cutting grass. Factors such as desirable cutting capability, power demand, and clippings management affect what type of blade to choose for cutting grass. According to cyclonerake.com, there are three main types of rotary mower blades; standard blades (low/medium lift), mulching blades and high-lift blades. In Table 1 below, the grass cutting technologies are compared.

Table 1: Grass Cutting Systems Comparison

	Standard Blades	Mulching Blades	High Lift Blades
Key Elements	-Curve in the blade creates a lifting air flow to pull up the grass for a uniform cut	-Greater curved edge than standard blades -Provides multiple fine cuts instead of one big cut	-Pulls up the grass to cut -Very exaggerated curve in the blade

2.3.5.1 Standard Blades [5]

Standard blades, also known as low-lift or medium-lift blades are designed with a slight curve along the edges. The curve in the blade creates a lifting air flow, which, assuming the grass is not wet, pulls it up for a uniform cut. The disadvantage of using standard blades is that it would need the implementation of a bagging system for clippings as the grass clippings will be the size of the excess grass less the blade height.

2.3.5.2 Mulching Blades [5]

Mulching blades, also known as three-in-one blades, are designed with a greater curved edge than that of the standard blade. The ends of mulching blades also usually contain “teeth” that allow the grass to pass through the blade, meaning that the same blade of grass experiences multiple fine cuts instead of one big cut. The fine cuts allow for faster decomposition, hence the name “Mulching” in the name of the blade. Mulching blades are ideal for the autonomous mower because grass clippings won’t have to be accounted for.

2.3.5.3 High Lift Blades [5]

High lift blades are basically standard blades but with a much more exaggerated curve. This exaggerated curve means that the mower system will be able to pull the grass up for cutting. It is advantageous to use a high lift blade when considering that the autonomous grass cutter is most likely going to encounter wet conditions. However, for this iteration of the project, the sponsor has specified that the grass cutter should be designed with base functionality when considering ideal conditions and wet conditions are not considered an ideal condition. Also, as the lift of a blade system increases, the power demand increases proportionally.

2.3.5.4 String-Based Grass Cutting

Since the customer’s health and safety constraint limits the only option of blade material to be durable, string-based nylon blade, further research was conducted on string-based methods of cutting. Using the previously researched information about the types of blades to cut the grass, it would be ideal to have a string-based blade with the high lift and mulching capability. High lift would pull the grass up, providing uniform cutting capability along with ensuring the lowest and cleanest possible cut. Mulching capability would make grass clippings an afterthought. However, the requirement of having a string-based cutting solution arises some challenges not considered when using a metal blade. Instead of relying

on an actual metal blade to cut grass, a string-based grass cutter works on the principle of using centripetal acceleration to spin a line fast enough to stretch and thus taut the line. When the line is stretched and taut, it becomes a cutting disk. This disk depends on factors, such as speed, torque, and line thickness to determine whether it will cut grass. The string-based blade must have enough speed to stretch and taut the line. A significant disadvantage of having to stretch and taut a string line in comparison to a metal blade is that it is not possible to design a curve into the string-based blade. Having no curve means that it is not possible to achieve a lifting feature to pull up the grass for a uniform cut. However, saving too much speed can create turbulent forces that create an unpredictable movement of the grass, including pushing the grass down and away from the string-based blade, resulting in a cut that is not uniform.

While speed is required for a string line to become a cutting disk, high torque is required to continuously overcome the resistance caused when the cutting disk encounters the shear force of grass. Torque and speed are inversely related. With that in mind, a low speed of 3000 rpm with a torque of 0.5099458 N-m has enough force to cut the grass depending on the radius of the string-based blade accounting for the design constraints of cost and power. There are more expensive DC Gear motors that provide better results but for this project, the budget towards the motors are limited. With a radius of 3 inches, it will result in a force of 6.692 Newtons. With a radius of 4 inches, it will result in a force of 5.019 Newtons. With a radius of 5 inches, it will result in a force of 4.015 Newtons. These observations show that with a larger string radius, the less force that will be outputted with the same amount of torque. Due to this research, a low speed, high torque and lowest string radius possible that will need to be considered to efficiently cut the grass. The thickness of the string has very small impact on the force of the strings to cut the grass since Nylon strings are very lightweight. On conventional metal cutting blades, the thickness and weight does have an impact on the force of the strings to cut the grass.

2.4 Engineering Specifications

The engineering specifications chapter describes and compares the project requirement specifications, technical requirements and the customer's desires. Engineering specifications that relate to this project are the records that provide detailed documentation of the construction, wiring, design, arrangement and applicable engineering details of the overall system design and processing components.

2.4.1 Project Requirement Specifications

The project requirement specifications refer to the specific design of the overall grass cutter system. The goal of this project is to use the components listed in the tables below to design a fully functional, Articulated AI-Assisted Solar Farm Grass Cutter. The project must contain a development board, microcontroller, motor driver chips, GPS module with built-in compass, voltage regulators, wireless communications, obstacle avoidance and detection sensors and Camera. The grass cutter will use low voltage and power consumption. It will include two rechargeable batteries. Table 2 shown below shows the overall project requirement specifications table with the description, target values and related standards.

Table 2: Overall Requirement Specifications (ORS)

Designation	Description	Target Value	Related Standards
ORS-1	Dimensions of Robot	≤ 2x2x2 feet	ABET Size Design Constraint
ORS-2	Dimensions of PCB	≤6x7 inches	ABET Size Design Constraint
ORS-3	Weight	≤40 pounds	ABET Weight Design Constraint
ORS-4	Power Consumption	≤4000Wh	ABET Power Design Constraint
ORS-5	Time to cut 50x10 area	≤15 minutes	ABET Time Design Constraint
ORS-6	Safe cutting and navigation	≥95% Accuracy	ABET Health and Safety Design Constraint
ORS-7	Damage to Environment	≥95% Accuracy	ABET Environmental Design Constraint
ORS-8	Maintenance Costs	≤\$10,000 per year for maintenance	ABET Economic Design Constraint
ORS-9	Design Integrity	100%	ABET Ethical Design Constraint
ORS-10	Manufacturability	100%	ABET Manufacturability Design Constraint

Table 3 shown below shows the billing requirement specifications table with the description, target values and related standards. Duke Energy and Orlando Utility Commission provided a budget of \$1,500. The target value is \$2,000 in case the budget goes over what the sponsors have provided for this project.

Table 3: Billing Requirement Specifications (BRS)

Designation	Description	Target Value	Related Standards
BRS-1	Project Cost Ceiling	\$2000	None, typical competitive size

Table 4 shown below shows the project requirement specifications table with the description, target values and related standards if applicable. The project requirement specifications are the selected components and parts needed to design and implement this project.

Table 4: Project Requirement Specifications (PRS)

Designation	Description	Target Value	Related Standards
PRS-1	USB Wireless Communications	≥ 50 -foot range	IEEE Wireless Standard
PRS-2	Motors Lithium Ion Battery	≥ 1200 Wh battery capacity	IEEE Battery Standard
PRS-3	Electrical Components Lithium Ion Battery	≥ 240 Wh battery capacity	IEEE Battery Standard
PRS-4	Perimeter Wire Lithium Ion Battery	≥ 120 Wh battery capacity	IEEE Battery Standard
PRS-5	GPS location and positioning	$\geq 90\%$ accuracy	IEEE Standard
PRS-6	Camera Vision	≥ 5 -foot range	IEEE Standard
PRS-7	I ² C Interface	$> 95\%$ Accuracy	IEEE I2C Standard
PRS-8	UART Communication	$> 95\%$ Accuracy	IEEE Standard
PRS-9	SPI Interface	$> 95\%$ Accuracy	IEEE SPI Standard
PRS-10	C Programming Language	$> 90\%$ Accuracy	IEEE C Standard
PRS-11	Python Programming Language	$> 90\%$ Accuracy	IEEE Standard
PRS-12	C++ Programming Language	$> 90\%$ Accuracy	IEEE C++ Standard
PRS-13	Voltage Regulators	$\geq 85\%$ power efficiency	IEEE Standard
PRS-14	Obstacle Avoidance Sensors	≥ 300 -meter range	IEEE Standard
PRS-15	Induction Sensors	≥ 2 -foot range	IEEE Standard
PRS-16	Battery Charge Sensors	$\geq 90\%$ accuracy	IEEE Standard
PRS-17	Operational Amplifiers	$\geq 90\%$ efficiency	IEEE Standard
PRS-18	DC Wheel Motors	≥ 0.5 N-m of Torque	IEEE Standard
PRS-19	DC String Motors	≥ 1 N-m of Torque	IEEE Standard
PRS-20	Software Testing	$> 95\%$ accuracy	IEEE Standard
PRS-21	Hardware Testing	$> 95\%$ accuracy	IEEE Standard

2.4.2 Technical Requirement Specifications

This section will describe all the technical requirements required with their target range and technical difficulty on a scale from 1 to 5 (1:Least Difficult to 5: Most Difficult). This is shown in Table 5.

Table 5: Technical Requirement Specifications

Number	Technical Requirement	Target	Technical Difficulty
1	Provide an articulated sweeping motion needed to move the weed whacker across the terrain and cut grass	$\geq 90\%$ Efficiency	2
2	To identify grass areas that need attention	$\geq 90\%$ Efficiency	3
3	Obstacle Avoidance	≥ 2 feet Range	3
4	Motion Control	$\geq 90\%$ Efficiency	3
5	Defined battery storage technology with charging capability	$\geq 90\%$ Efficiency	1
6	Nylon String-Based Blade to cut grass	$\geq 90\%$ Efficiency	2
7	Kill Switch that can turn off the cutting system and locomotion	≥ 50 ft.	5
8	Safely Navigating through uneven terrain without capsizing while avoiding a series of obstacles	≥ 3 in. differential over	4
9	Cut grass under obstacles	≤ 2 ft. above the ground	2
10	Maintain acceptable grass height	≤ 6 in.	2
11	Must cut large areas and trim around PV Support Structures	≥ 500 sq. ft.	4
12	Size of Robot	$\leq 2 \times 2 \times 2$ ft.	1
13	Obstacle Detection	< 5 inches	3
14	Avoid any damage to surrounding infrastructure, the environment and humans	$\geq 90\%$ Efficiency	3
15	Time to charge from 25% level to 100%	≤ 2 Hours	1
16	Uniformity of cut	≤ 6 in.	4
17	Percent of total grass area cut and time	≥ 500 sq. ft. in 15 minutes	2
18	Stay in Boundaries	$\geq 90\%$ Efficiency	3
19	System Weight	≤ 40 lbs.	1
20	System Cost	$\leq \$1500$	3
21	Torque of Blade Motors	≥ 1 N·m	5
22	Force of Blade Motors	≥ 5 N	5

2.4.3 Engineering Market House of Quality Analysis

The Engineering Market House of Quality Analysis establishes the connection between the customer's desires and technical requirements to improve the product. Of the 22 technical requirement specifications listed in Table 3 in chapter 2.5, the 10 most important ones were selected to compare with the customer's desires. This table shows the positive and negative correlations between the customer's desires and technical requirements of the grass cutter. Every technical requirement has a corresponding target value with the corresponding technical difficulty from 1 to 5, with 1 being the easiest and 5 being the most difficult. A few of the demonstratable specifications that will be shown will include avoiding obstacles at a range greater than 2 feet, detecting obstacles at a range greater than 5 inches, uniform cut of grass of at least 6 inches, and kill switch technology of a range of at least 50 feet. Figure 1 below shows the correlation between the Customer's Desires and Technical Requirements.

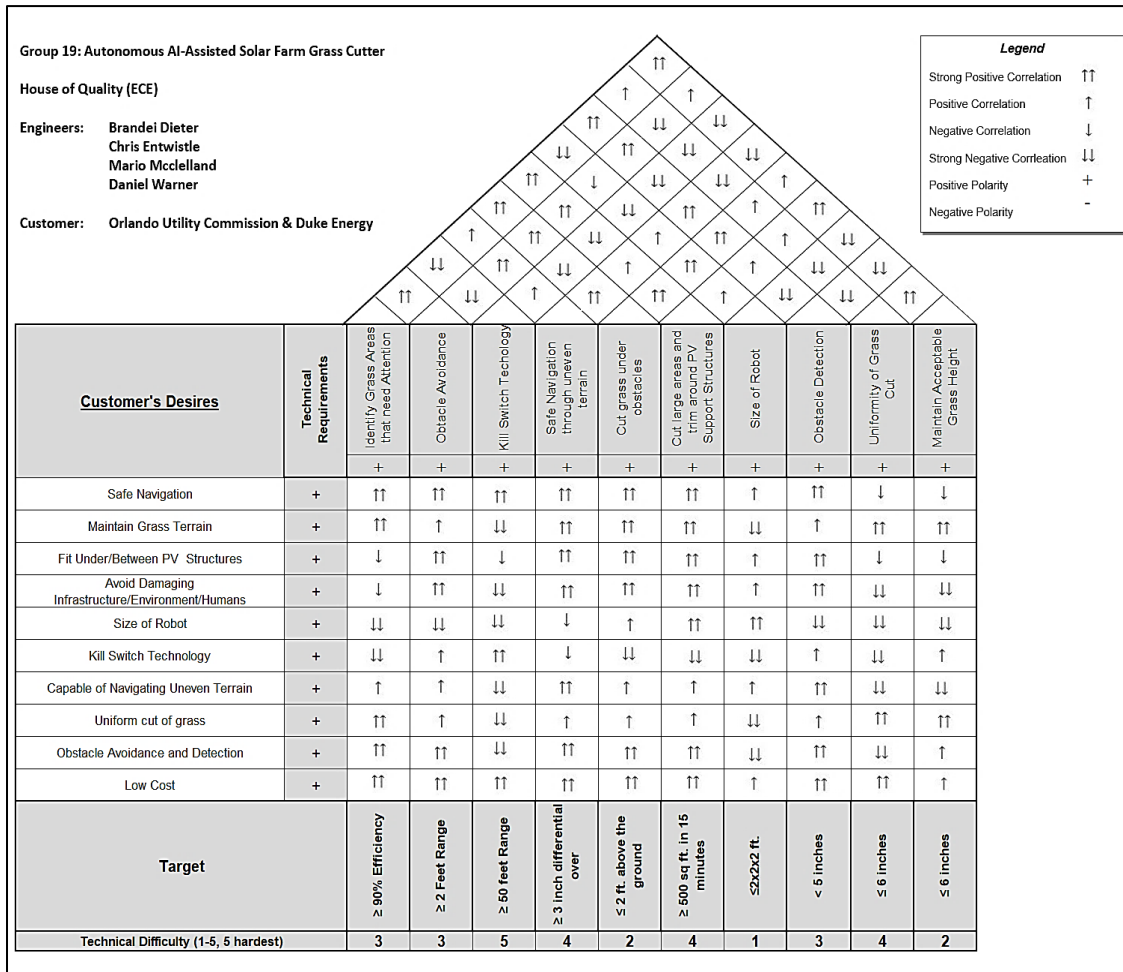

Figure 1: House of Quality Trade-Off Table made by Christopher Entwistle

2.5 Possible Designs and Block Diagrams

In this section, the possible hardware and software designs and block diagrams are described and shown. This includes the hardware design of the grass cutter and boundary system. This includes the software design of the grass cutter system.

2.5.2 Hardware Block Diagram

The possible Hardware Block Diagram shows the overall main components of the hardware that will be needed in the Grass Cutter System. There will be a battery that will power the electrical components through a voltage regulator. The electrical components will communicate with the laptop, motors and microcontroller. The possible hardware block diagram for the Grass Cutter System is shown in Figure 2 below.

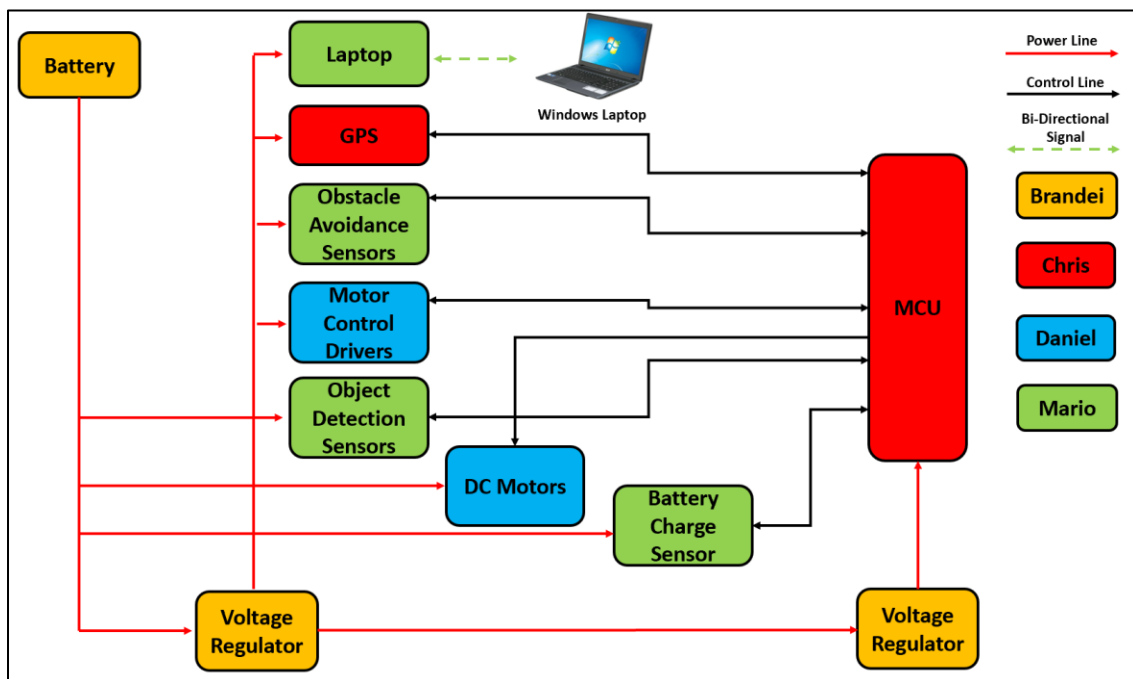

Figure 2: Possible Hardware Block Diagram for the Grass Cutter System made by Brandei Dieter

The possible Hardware Block Diagram shows the overall main components of the hardware that will be needed in the boundary system. There will be a battery powering the perimeter wire generator circuit through a voltage regulator. The boundary receiver circuit will detect the signal given off from the perimeter wire from the perimeter wire generator circuit and relay the signal to the microcontroller to do the proper operations. The possible hardware block diagram for the Boundary System is shown in Figure 3 below.

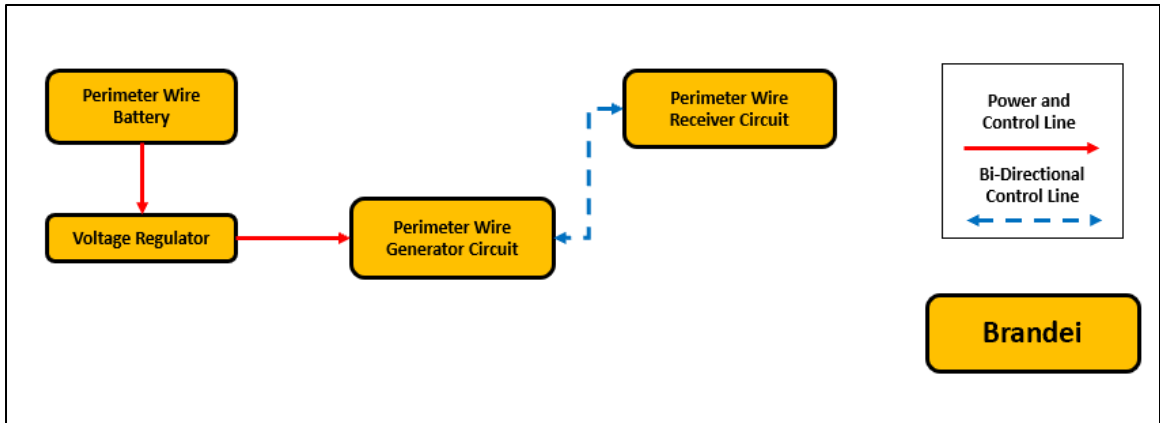

Figure 3: Possible Hardware Block Diagram for Boundary System made by Brandei Dieter

2.5.3 Software Block Diagram

The possible Software Block Diagram shows the overall software functions of the overall main components that will be needed in this System. Once the battery is powered on, it will power on the microcontroller and components. The functions of the obstacle avoidance sensors, obstacle detection, GPS module, motor control, battery charge sensor and the laptop application are shown below. The possible software block diagram is shown in Figure 4 below.

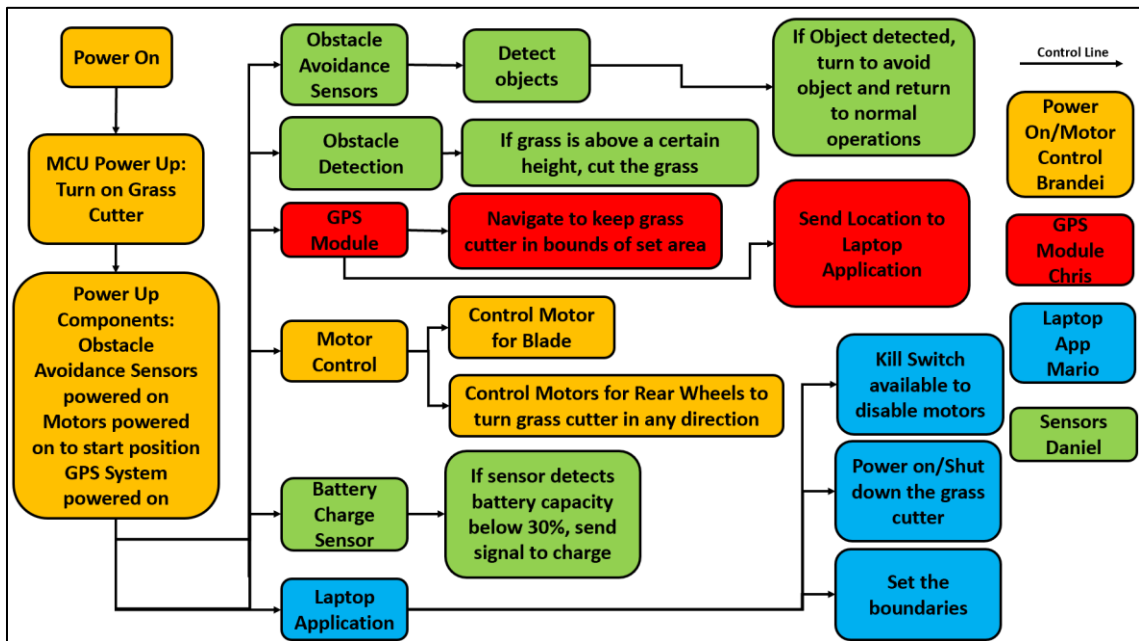

Figure 4: Possible Software Block Diagram made by Brandei Dieter

3. Research and Part Selection

Prior to building a prototype, research was conducted to find technologies that relevant to the project. After choosing which technologies would be relevant toward the project, parts and components were explored, compared, and chosen. This section of the project documentation is used to identify and describe the relevant technologies that may be used in this project, the research done to help with the part selections, and the strategic parts comparison and selections.

3.1 Relevant Technologies

This section contains technologies that were found to be relevant towards the design of the project. Extensive research was then conducted to aid in the process of selecting the technologies, parts and components that will be used in the prototype.

3.1.1 Navigation Technology

This section will describe the different technologies that may be used in this project. This will include path planning, obstacle detection, location and positioning, map building and types of localization and mapping. This technology is vital for the overall navigation and motion of the grass cutter robot.

3.1.1.1 Path Planning [6]

Path planning will be useful for this project to cover all the areas that need to be cut in an intelligent way. Of the relatively straight routes that could be implemented, it could either repeatedly go through the field from top to bottom, or spiral around from the boundary line to the middle of the field. The spiral seems like the more ideal selection because that will result in fewer 180° turns. 90° turns will be easier for the mower to turn and get all the areas of the grass. For the competition for this project, the grass cutter will be tested in a 500 square foot area. This area will be rectangular and irregular boundary lines are unlikely, which is perfect for the spiral route. This method will reduce the amount of times the robot will visit a path that it has already completed and maintain the speed of utilizing a uniform navigational pattern. Figure 5 below shows an example of how the path planning could work around the PV structures in the Solar Farms.

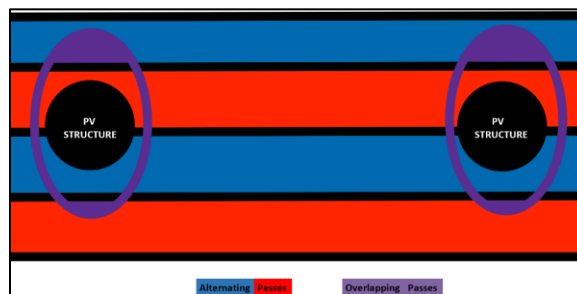

Figure 5: Path Planning Diagram around PV Structures made by Brandei Dieter

In Figure 5, the curves will change depending on the shape and layout of Solar Panel Infrastructures. The red and blue paths are alternating passes the robot may take in route. The purple path is the overlapping passes the robot may take to cut around the PV structures. With path planning, it could minimize the amount of overlapping passes it may take. The robot will need to adjust its navigation depending where the obstacle is positioned. This can be done with minimal computations and algorithms. This should make the grass cutter more efficient by planning its path and never cutting over the same spot twice. This technology is one of the most intelligent ways to maintain the grass.

3.1.1.2 Map Building [6]

Several different methods are available for autonomous vehicles to map the environment around them. Different methods depend on the type of sensors that are being used for Obstacle Detection and mapping. Common applications used for map building are lasers, LiDAR sensors and cameras. Table 6 below shows the technologies that may be used for Map Building.

Table 6: Technologies used for Map Building

	Lasers	Cameras
Key Elements	<ul style="list-style-type: none"> -Use of lasers for map building -Creates a 2-D occupancy grid map of the objects and free space -Predicts the odds of an object being present -Higher Costs -More comprehensive -Great for indoor environments 	<ul style="list-style-type: none"> -Lower Costs -Use of cameras for map building -Utilizes Computer Vision -3-D imaging -3-D image reconstruction -Aid in Path Planning -Obstacle Detection -Obstacle Recognition -Tracking

3.1.1.2.1 Lasers for Map Building

With lasers, there is a technology that uses lasers to fill in a 2-D occupancy grid map. This technology does not require the use of cameras or computer vision. It uses lidar which is more comprehensive and expensive. For instance, a rotating sensor can be placed on top of the robot and constantly scans the environment in every direction. This will fill a grid map with all the obstacles and objects that may be in its line of path. A lot of lidar applications are used in indoor environments. The way the lidar process works is the created grid map divides the environment into a grid where each cell contains the probability of an obstacle or object present by using the measurements from the sensors. A laser can either pass through free space or hit an obstacle or object in its path. The open space is updated with (0.0, white) and cells with an obstacle or object are updated with (1.0, black). Although this method is an efficient and intelligent way to map the field of the Solar Farm, it is not feasible with the resources available for this project. It is too expensive for the budget of this project. Figure 6 below shows how the lasers map build.

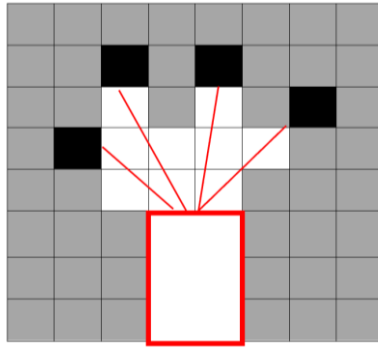

Figure 6: Laser Map Building made by Brandei Dieter

3.1.1.2.2 Cameras for Map Building

With cameras, the use of computer vision can be implemented for map building. Digital cameras create images consisting of pixels which can be analyzed using the open source computer vision and OpenCV libraries and algorithms. Cameras have various applications that can be used for map building such as 3-D imaging, 3-D image reconstruction, path planning, deep learning, obstacle detection, object recognition and tracking. They can be used to perform visual simultaneous localization and mapping. The implementations of techniques such as Simultaneous Localization and Mapping (SLAM) and Large Scale Direct Simultaneous Localization and Mapping (LSD-SLAM), can be used in conjunction with a camera. This offers a wide range of features that are extremely useful for the autonomous AI-Assisted Solar Farm Grass Cutter in this project. The use of the camera and its capabilities offer a huge advantage for autonomous robots. With cameras, the use of sonar, lidar or infrared sensors are not needed but an added feature as a secondary protection element. Cameras are an ideal, cost efficient way to implement intelligent tracking, mapping and detection to this project. The autonomous mower could be capable of starting in an unknown environment then build an entire map of the environment and simultaneously localize itself within the map it created. For instance, the autonomous grass cutter would be able to enter any solar farm and immediately adapt and learn the environment around it. This feature is a very useful and new growing technology that is a strong element for autonomous devices like this project. Cameras for map building are the most ideal given the resources and design constraints of this project. Figure 7 below shows a simple diagram of a camera for map building of 3-D reconstructions.

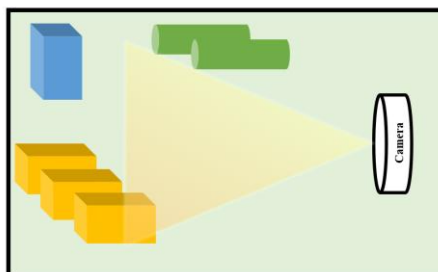

Figure 7: Camera Map Building made by Brandei Dieter

3.1.1.3 Self-Localization

Self-Localization has an important role in robots. It is used to estimate the distance of the robot from a specific object and find the position and direction of the robot with respect to a global fixed coordinate grid. Various types of self-localization will be explained in the following sub-chapters such as odometry, Simultaneous Localization and Mapping (SLAM) and Large Scale Direct Simultaneous Localization and Mapping (LSD-SLAM). These self-localization technologies would be extremely useful to implement into this project. It will provide efficient processes that can keep track of the robot's position and location, creating maps using its surround environment and landmark extraction and capable of depth map estimation to reconstruct dense 3D images and using image intensities for tracking and mapping. All these techniques rely on math and measurement models to optimize its functionality. Table 7 below shows the technologies used and its key elements for the technologies with Self-Localization.

Table 7: Self-Localization Technologies

	Odometry	SLAM	LSD-SLAM
Key Elements	<ul style="list-style-type: none"> -Can keep track of where the robot is at anytime -Algorithms are utilized for calibration and optimization -Positions are determined by the velocity of the wheels and the forces acting on the robot 	<ul style="list-style-type: none"> -The surrounding environment is used to update the position of the robot -Uses an Extended Kalman Filter -Landmark Extraction -State/Position Estimation -Landmark Update 	<ul style="list-style-type: none"> -Depth Map Estimation -Directly operates on image intensities for tracking and mapping -Runs in real time -Uses raw information from the image sensor -Higher accuracy in sparsely textured environments -Denser 3D reconstruction

3.1.1.3.1 Odometry [6]

Odometry is a vital element in using the data from the sensors to estimate the change in position over time. It can be used to estimate the robot's location relative to a starting point and keep track of where the robot is at any time. Since the robot is driven by the two front wheels on either side of the grass cutter with one caster wheel following, the unicycle model of control can be implemented. The equations are shown in Table 8 below.

Table 8: Odometry Equations [6]

Equations	Descriptions
$x'(t) = v(t) \cos(\theta t)$	Robot's state of x with respect to (x, y, θ)
$y'(t) = v(t) \sin(\theta t)$	Robot's state of y with respect to (x, y, θ)
$\theta'(t) = \omega(t)$	Robot's state of θ with respect to (x, y, θ)
$v_r(t) = \frac{v_r(t) + v_l(t)}{2}$	Velocity of the right wheel
$v_l(t) = \frac{v_r(t) - v_l(t)}{b}$	Velocity of the left wheel b is the length of the base from each wheel

This odometry will shift over time without a method to correct it. An optimization method that can be used is Borenstein's method. It can be used in modeling and estimating the error of odometry of a robot. A planned arbitrary test route is needed to calibrate and optimize the odometry. The model will calculate repeatedly by taking the robot along a path several times until the odometry is fully optimized and accurate. This model and software algorithms can be utilized through a computer software such as MATLAB. It uses all the forces that will be acting on or from the robot. The equations that are used are shown below in Table 9.

Table 9: Borenstein's Method Equations [6]

Equations	Descriptions
$\Delta U_L = c_L N_{L,k}$	Incremental distance for the left wheel $N_{L,k}$ is the left pulse increment for the wheel encoders for a sample time k c_L is the conversion factor that translates the encoder's pulses into linear wheel displacement for the left wheel
$\Delta U_R = c_R N_{R,k}$	Incremental distance for the right wheel $N_{R,k}$ is the right pulse increment for the wheel encoders for a sample time k c_R is the conversion factor that translates the encoder's pulses into linear wheel displacement for the right wheel
$\Delta U_k = \frac{(\Delta U_R + \Delta U_L)}{2}$	Incremental displacement of the center point c
$\Delta \theta_k = \frac{(\Delta U_R - \Delta U_L)}{b}$	Incremental angular displacement b is the length of the base from each wheel
$\theta_k = \theta_{k-1} + \Delta \theta_k$	Robot's kinematic state of θ_k with respect to (x_k, y_k, θ_k)
$x_k = x_{k-1} + \Delta U_k \cos \theta_k$	Robot's kinematic state of x_k with respect to (x_k, y_k, θ_k)
$y_k = y_{k-1} + \Delta U_k \sin \theta_k$	Robot's kinematic state of y_k with respect to (x_k, y_k, θ_k)

This model can be shown in Figure 8 below.

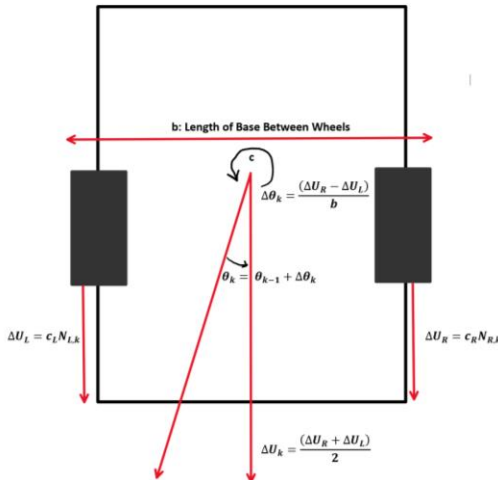

Figure 8: Borenstein's Model Diagram on Grass Cutter Model made by Brandei Dieter

3.1.1.3.2 Simultaneous Localization and Mapping (SLAM) [7]

Simultaneous Localization and Mapping is a concept used to create algorithms that combine the map making and self-localization elements of navigation. This process uses the relationship of self-localization and human perception of their environment. It uses the environment to update the position of the robot like how the human eye perceives an environment and will know its position. This is done mostly through an Extended Kalman Filter (EKF), a recursive filter. Being a recursive filter, the equations can effectively be updated and expressed in closed form. An Extended Kalman Filter estimates the position of the robot using odometry data and observed landmarks in an environment. Simultaneous localization and mapping use the Extended Kalman Filter by constantly updating a map design. It uses a group of matrices and set equations to do so. It will constantly update the current position using odometry data, the estimated position from re-observed landmarks and new landmarks pertaining to its current position.

3.1.1.3.3 Large Scale Direct Simultaneous Localization and Mapping [7]

Large Scale Direct Simultaneous Localization and Mapping (LSD-SLAM) is capable of depth map estimation, map optimization and tracking. It runs in real time and directly operates on image intensities for tracking and mapping. This system works by utilizing computer vision using one camera and uses all the raw information from the image sensor which results in higher accuracy than other methods in sparsely textured environments and provides a much denser 3D reconstruction. LSD-SLAM does not require high processing specifications. It uses a monocular SLAM algorithm. For depth map estimation, it takes each image that the microcontroller receives as a frame and the algorithm identifies the important keyframes and adds them to the map. In the case that the camera moves outside the range of the current keyframe, a new keyframe is initialized from the most recent image. This is done by projecting points from nearby keyframes to create a depth map. A current keyframe is replaced with a new keyframe and then used along with the other keyframes to track any new frames. For each subsequent frame that is not a keyframe, the algorithm performs a baseline comparison to optimize the map. For tracking, it takes the new image and tries to estimate the current camera pose with respect to the current key-frame pose by using formulas to minimize the variance-normalized photometric errors. For map optimization, each key-frame is scaled to have an average inverse depth of one. The alignment of the key-frames is required with the consideration of each key-frame having a different scale. This is done using formulas to minimize errors on the photometric and depth residual. After the key-frame is added to the map, detection of loop-closure is done with several key-frames that are close enough in proximity to detect a loop, also known as loop-closure. This process is done by utilizing a reciprocal tracking track that compares the transformation of the original key-frames to the other key-frames while still accounting for uncertainties. The solution is found when the algorithm has detected a loop-closer. This form of optimization provides high accuracy and calibration for mapping. This method is easily implemented with an open source library. The suggested applications to use this method is a monochrome, global-shutter camera with fisheye lenses with a visual input of 480 pixels at 30Hz. Figure 9 below shows an overview of how the Large Scale Direct Simultaneous Localization and Mapping works.

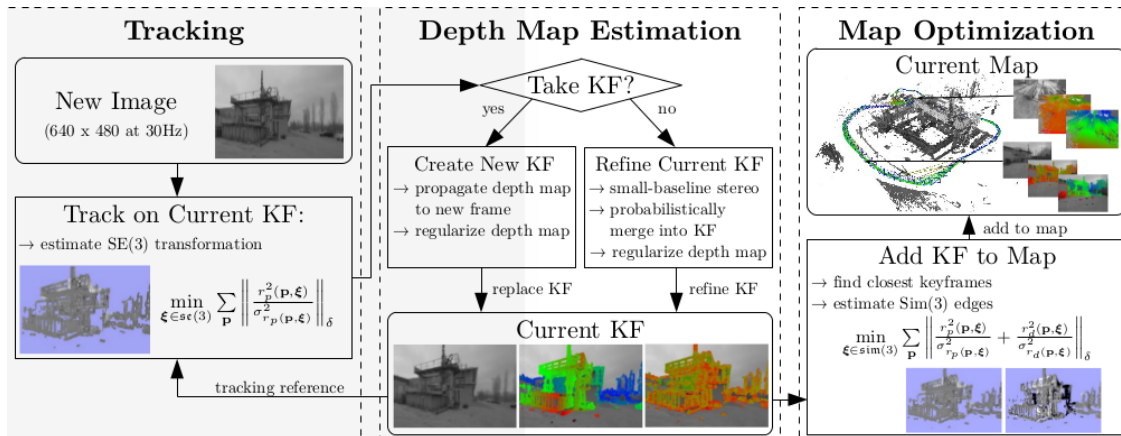

Figure 9: Overview of How LSD-SLAM Works used with reference from medium.com [7]

3.1.1.4 Night Vision

Night vision will be useful for the grass cutter if it had the capability of cutting during anytime throughout the day. For instance, the grass cutter could charge during the day via solar power in the future and cut at night while the temperatures are down. The Night Vision cameras that are of interest have LEDs that turn on automatically when it gets dark. This will allow the computer vision to run at any time during the day. They include automatic IR-cut when the surrounding light is dark. They automatically recognize day and night modes. The camera has 2 photosensitive resistances that detect ambient light intensity and the center sensor has a switch for control.

3.1.1.5 Computer Vision

Computer Vision is an efficient way to control navigation of the robot. Open Source Computer Vision was originally developed by Intel, to provide real time computer vision and image processing. It can efficiently help robot localization, obstacle detection, obstacle avoidance, path planning and mapping. These strong elements are intelligent ways to minimize interaction with other objects, infrastructures and humans, minimize damage to the surrounding environment, maximizing efficiency of the energy spend versus distance travelled, and map building. Computer Vision works by segmenting images to obtain useful data about its surrounding environment which is used in conjunction with a camera. It will analyze the pixels in the images it takes. There are many technologies that can be applied to computer vision such as blob detection, facial detection, object recognition and image recognition.

3.1.1.6 Location and Positioning

Location and positioning of the robot is vital to this project. This could be an important piece of technology that will pinpoint the location of the grass cutter after the main system has run out of battery life. The technologies that can be implemented are shown in Table 10 below.

Table 10: Location and Positioning Technologies

	GPS and Compass Module	Inertial Measurement Units
Key Elements	<ul style="list-style-type: none"> -Positioning and location -Indicates direction -Mapping -Precise overall locomotion and position of the robot 	<ul style="list-style-type: none"> -Positioning -Velocities, Angular Rates, Altitudes and Speeds -Specific Forces -Magnetic Fields -Gyroscope, accelerometers, magnetometers

3.1.1.6.1 GPS and Compass Module

GPS and Compass Modules are capable of positioning and location. The compass will aid in indicating directions. The GPS module in conjunction with the compass has the capabilities of control to a destination or location selected, how much distance a robot has covered, how much further a robot can go, recognize on a map where a robot is and what position the robot is in. These are widely used for commercial and personal uses. Algorithms can be implemented in conjunction with a GPS and compass module. Working together, the overall locomotion and position of the robot can be more precise. When the grass cutter dies, the location can be pinged to an application to let the user know where the grass cutter is, so the system can be charged. The compass can be used to aid in the turns the robot will need to make and provide the angles to which the robot will turn.

3.1.1.6.2 Inertial Measurement Units [8]

Inertial Measurement Units is a device that can measure and report data such as altitudes, velocities, specific forces, angular rates, magnetic fields, and position. They come with various applications on board such as gyroscopes, accelerometers or magnetometers. Some models can be used in conjunction with a GPS module. Though the information an Inertial Measurement Units could provide for this project, it is unnecessary for this application. They are typically used in applications such as maneuvering aircrafts, spacecrafts, unmanned aerial vehicles and satellites.

3.1.2 Batteries

The battery is going to be the main source of power for the grass cutter's system. Multiple batteries will be used based on the design constraints and requirements. The battery selection is vital to the overall output, functionality and capability of autonomous mower. The concern of the battery regarding to weight is how it will affect the speed, traction and weight distribution of the grass cutter. For example, if the battery is too heavy, it could affect the speed negatively and not cut at a desirable speed. The same case, previously discussed, would also occur if the chosen battery doesn't meet the power demands of the system.

Researching a variety of batteries led to the discovery that there are 2 types of batteries, primary and secondary. A primary battery is a battery that is charged using a non-

repeatable chemical reaction, meaning that it is not rechargeable. The device should have the least amount of maintenance. It is impractical to use a non-rechargeable battery. A secondary battery is rechargeable which is ideal for this project. There are basically four major chemistry categories for rechargeable (secondary) batteries; Lithium-ion (Li-ion), Nickel Cadmium (Ni-Cd), Nickel-Metal Hydride (Ni-MH), and Lead-Acid. In Table 11 below, it shows the comparison of different battery types.

Table 11: Battery Type Comparison

	Lithium-Ion	Nickel Chemistry-Based	Lead-Acid
Key Elements	<ul style="list-style-type: none"> -High battery capacity -High discharge rate -Low charge time -High Power Efficiency -Really light 	<ul style="list-style-type: none"> -Best cost per amount of charge cycles -Perform well in hot environments 	<ul style="list-style-type: none"> -Relatively cheap compared to Lithium-Ion Batteries -Really heavy -Lower discharge rate

3.1.2.1 Lithium-Ion

Lithium-ion batteries are generally a lot lighter than the other types of rechargeable batteries. Lithium-ion is a highly reactive element. They have a higher energy density compared to other batteries. For a perspective, an article titled “How Lithium-ion Batteries Work” written by Marshall Brain, says that a typical lithium-ion battery can store 150 watt-hours of electricity per 1 kilogram of battery. The article then goes on to list that the typical nickel-metal hydride battery has about 60 to 70 watt-hours per kilogram and that a lead-acid battery has about 25 watt-hours per kilogram. When compared to a lead-acid battery, a lithium-ion battery saves a sixth of the weight a lead-acid battery to store the same charge. Also, a lithium-ion battery can handle numerous charge/discharge cycles with little degradation and without a memory effect when compared to the other 3 chemistry categories.

Although a lithium-ion battery sounds ideal, the battery does come with a couple trade-offs and disadvantages when compared to the other chemistry categories. One of the biggest trade-offs that will affect the budget is the fact that a lithium-ion battery is the most expensive battery out of all the options. The Lithium Ion batteries require a battery management system to prevent operation outside of the cell’s safe maximum charge, minimum charge and temperature ranges. The Lithium Ion batteries that will be chosen in this project will have security features that include over-charge protection, over-voltage protection, short circuit protection, over-temperature protection, over-discharge protection and over-power protection. They are available with productA+Chip increases 20% of power. These batteries have large capacities and persistent outputs. This battery is ideal for this project despite the higher costs. Compared to the Lead-Acid battery, it is a lot light. Comparing the 1200W-h batteries, the lithium ion would weigh an average of 5 pounds versus the Lead-Acid battery that would weigh an average of 50 to 60 pounds. There are

battery charge sensors built in, charging ports and power terminals available already integrated into some options of Lithium Ion batteries available online.

3.1.2.2 Nickel Chemistry-Based

The nickel chemistry-based family of batteries are known for ruggedness. Nickel chemistry batteries have the best cost per amount of charge cycles and perform better than lithium-ion batteries in hot environments. The nickel-metal hydride battery is a non-toxic evolution of the nickel cadmium battery. The comparisons made in this document will be made against the Ni-MH chemistry battery. When compared to a lithium ion battery, although the nickel-metal hydride battery is better in higher temperatures, it has significant drawbacks. The nickel-metal hydride battery requires complex charging algorithms to avoid any memory effects or overcharging. On top of requiring complex charging algorithms, the Ni-MH battery has a high self-discharge rate; as high as about 20% discharge over 24 hours.

3.1.2.3 Lead-Acid

The lead-acid batteries are relatively cheap compared to the Lithium Ion batteries but extremely heavier. The lead-acid batteries come in two configurations of starter and deep-cycle batteries. The consideration of deep-cycle over a starter lead-acid battery would be more ideal due to the mower will need constant power instead of demanding a high spike like starting a combustion engine would have. The advantages are the lower costs. It has the lowest self-discharge rate. This battery is not ideal for this project because it is too heavy despite the cheaper costs.

3.1.3 Battery Charge Sensors

The battery charge sensors are a great way to manage the power systems in this project. LiPo Fuel Gauges connect to the battery of choice and uses an algorithm to detect the relative state of charge and direct Analog/Digital measurements of the battery voltages. It communicates over the I2C and will alert the pin when the charge has dropped below a certain percentage to do the proper operations.

3.1.4 Overall System Control

The overall system control will be made up of different subsystems for the electrical and computer science team to design. Overall control of the subsystem requires path planning, motor drive system, and power distribution throughout these subsystems. Research throughout the elements required for this project will lead to in depth detailed descriptions of subsystems within the overall control operations for the autonomous grass cutter. Having discussed the basics of what battery and how computer vision works, it is known that these resources are needed and will be assigned to different electrical sub systems. From the computer vision inputs, appropriate outputs need to be established through a microcontroller. The overall system must communicate through inputs and outputs. Almost every electrical component discussed in the control system section, 3.1.4, needs to be

compatible. The reasonings as to why these components are selected and what system responsibilities each one is used for will be elaborated on.

3.1.4.1 Microcontrollers

Microcontrollers considered for this project must include video input for the path planning control. More than one microcontroller may be required. A microcontroller generally consists of a processor, memory, and input/output peripherals. Inputs for the path control for the autonomous robot may include sensor signals as well as the Computer Vision signals being inputted. The inputs must lead to several outputs for the driving motors used to control the wheels on the robot. The amount of control provided by the microcontroller(s) used in the path planning and driving system of the robot do have some limitations based on which controller is used.

As stated, the CV input may be necessary and video input is required. Through product research, the Raspberry Pi 3 contains a camera serial interface (CSI) port to connect a Raspberry Pi camera for video input. This application allows for the CV to be directly inputted into the device. Through further microcontroller investigation of autonomous robots, it is found that some widely used Arduino microcontrollers are used. The Manscaper project used the ATmega328P microprocessor board. The Arduino board mentioned did not contain a direct video input from the CV camera located on the mower. Instead of direct input, for this project the team installed a RN-XV Wifly Module. This product wirelessly connected the video inputs from the CV program to the Arduino board used. Limitations and constraints are created when operating wirelessly with the use of a laptop. Distance of signal processing may become reduced too much for the specification requirements of this project.

The size of different controllers has an impact as to how many input and output options are available. The minimum amount of inputs for the autonomous robot to avoid all obstacles is desired for the grass cutter to keep a minimum amount of outputs. However, a goal for this project is to cut grass as close to an object as possible; in order to get close, many sensors and the use of multiple object avoidance systems may be carried-out resulting in many inputs. A single smaller microcontroller may not maintain enough pin locations. To establish how many locations will be necessary, it will be important to create a subsystem for the obstacle avoidance and the microcontroller must be assigned and used in the operations for this system.

Since path planning involves avoiding obstacles and the microcontroller is used to process all the signals inputted from sensors and CV, the microcontroller must also use output pins to control wheel and blade motors. This is if the blades must be turned off when certain obstacles are approached. With the chosen microcontroller being assigned to the avoidance subsystem, it must also communicate to these motors. Consequently, the drive system also uses the microcontrollers and the outputs available on the equipment must have enough room to create motor movements accordingly.

3.1.4.2 Processors [8]

The microcontroller unit contains an on-board processor. A processor or the CPU located on the microcontroller, PCB, or development board used in the project must be capable to read and exchange data types between the signals processed in the different subsystems. This is only if the data needs to be transferred between units. The size of the main processor located on the Arduino boards primary used for autonomous robotic projects depends on how many inputs are on the board and how many bits of certain data types may need to be executed on. The given CPU spec comparisons between different boards can be found at the Arduino online site listed in the references of this document. Determining which size processor is required to compute the delivered signals will need to be determined in reference to which desired board contains all needed electrical processing components. Certain types of processors require certain types of memory to maintain CPU speed. The processor reads and writes data to and from certain memory locations differently. This may create problems regarding speed and efficiency. Bit processing processors for Arduino boards ranges from 8-bits, to 16-bits, to the largest 32-bit processor.

Certain used processors for each board also operate at different CPU speeds. The minimum speed of different processors located on the Arduino boards is 8MHz to the highest speed of 48MHz. The wide variety of speeds given to the processors is mainly a consequence of the size of flash memory being interfaced with the processor. For alternative memory and cache hierarchies being practiced on the device, more clock cycles become needed to read and write data using the processor. The overall system operation for this project will need a decent amount of flash memory to download and hold the computer science team's obstacle avoiding pathing codes for the robot. It can be expected to have a CPU clock rate greater than 8MHz to assure no delays can occur that take too long for the robot to respond accordingly. Another note is that the video input must be executed on a Raspberry Pi type of video input before the path control signals are processed onto the Arduino microprocessor type of controller board. Coding interrupts may also be necessary for the robot to make use of sensors and not only depend on CV. For these reasons it is important for the robot to quickly receive instructions after the code has been operated on by the processors ALU. The speed must provide the data quickly enough to assure signals reach motor shields and drive operations are executed before the robot collides with approaching obstacles.

After determining the bit size required and processor speed, power consumption becomes the constraint between electrical subsystem units. The studied Arduino microcontroller voltage inputs range from 2.7V to 12V. These voltages are required for the processors interfaced and practiced on the boards. It becomes apparent that, to save energy, a low input voltage into a processor is desired. If only a 32-bit processor can get all the tasks needed for the grass cutter project accomplished, then a 64-bit processor that requires a higher input voltage should be avoided. Keeping a minimum input voltage into the processing unit will require the team to sufficiently make used of all the ALU power possible. Another aspect of energy consumption on the Arduino processors is the Universal Asynchronous Receiver/Transmitter (UART) operation provided. The UART system is created to transmit data into the processors and interrupt an executing code. The UART

system is designed and added into some of the processors used for Arduino microcontrollers. If the team decides not to transfer data using the UART option, then choosing a processor without this incorporated mechanism will save voltage supplied from the power distributing subsystem. A chart of different processors used from Arduino is provided, explaining the trade-offs between different input voltage needed, available memory interfaces, and bit sized operations allowed in ALUs. The processors are compared as shown in Table 12 below with reference to datasheets [A14], [A19] and [A20].

Table 12: Processors Comparison

	ATmega2560 [A14]	ATmega328P [A19]	Intel Curie [A20]
Key Elements	<ul style="list-style-type: none"> -High Performance Low Power 8 Bit Processor -Interfaces 256 KB of Flash Memory for Code -Contains 4 UART digital signal peripherals with 6 other digital signal transmitters -Operates input voltage of 5V -CPU speed 16 MHz 	<ul style="list-style-type: none"> -High Performance Low Power 8 Bit Processor -Interfaces with 32 KB flash memory with read-while-write capabilities to further reduce power consumption. -Contains 1 UART digital signal peripherals -Input voltages between 1.8-5.5V -CPU speed 20MHz 	<ul style="list-style-type: none"> -Low-power integrated DSP sensor hub and pattern matching technology-32 Bit -Interfaces 384 KB of flash memory with 80 KB SRAM -Bluetooth Low Energy (BLE) Capability -Operating input voltage of 3.3V -CPU speed of 32MHz

3.1.4.3 Development Boards

As for a development board for the grass cutter project, a specified amount of memory on a microprocessor will be implemented on the board. A development board is a printed circuit board (PCB) that contains minimal electronic components necessary for the computer engineer to develop and download applications onto. The computer science team and the computer science engineer will program and interface the chosen components onto one PCB, unless two different platforms are needed. The processor required to compute bit results and properly format data onto the microcontrollers will need to be redesigned onto the PCB that incorporates more technologies used for this project. There are many historical manufactured development boards that were built to offer and supply the electrical and computer science industries foundations for technological growth. Some were designed originally with accurate clocking and digital ASCII displays. Some were developed for analyzing different types of instruction-set architectures such as stack memory, register-only memory, accumulator memory, etc. By designing and including different types of architecture that can be practiced on a uniquely designed development board, the electrical and computer science engineers working on the project can build a development board capable of completing tasks only suitable for the at-hand project. Therefore, designing power efficient interacting mechanisms onto a PCB that designate

power distribution to each component functioning in a timely manner for the project. Development board research is necessary for this project to discover exactly what electronic mechanisms are implemented onto different manufactured development boards while answering the questions as why and how the electronic devices were constructed to help future engineering projects as this one.

In the instance of alternative development boards, the 8085 AT development board from Intel is design like a micro-processing unit with its own assembly code building and decode compilation capabilities. It contains its own instruction set for assembly coding an embedded program onto the board. Stack pointer for operation is included in the firmware for the development board. Additionally, an accumulator is provided and connected to an 8-bit data bus and the ALU for logical operations and LD/SW operations. The board contains five flag registers for embedded system coding manipulations. The intel development board comes equipped with its own interrupting digital signal controls and support UART functionality. An equipped 16-bit address bus can map 64KB of memory locations. The board can also include add-ons if desired. This is an example of a development board that intel has created and made available for future project goals.

Another example of a development board is through Texas Instruments. The MSP430FR5994 developer kit. The system provides all aspects of a microcontroller kit with debugging firmware for on-device coding with the use of flash memory. The development board has MSP compatible software available through Texas instruments' website that allows users to experiment different types of code algorithms. LED lights on the board represent different signals to pin locations for assurance that the software is accurately running on the device. The digital signal processing UART functionality also has been added onto the development board for signal transmitting applications. Like all manufactured microprocessors, example codes are provided for users and future code writers. C-programming standards and assembly coding standards are interfaced with the hardware on the development boards and the OS of linked machines making the development boards compatible between many different devices. The manufactured development boards and their datasheets provided by Intel, Texas Instruments, and Arduino online help realize functionalities of different electrical devices that can be implemented onto any PCB. The significance of the different instruction sets with unique compilers on the development boards allows researchers to test coding algorithms with the use of LED lights.

The computer architecture on different boards may have evolved into requiring more memory space for further complexity in memory hierarchy. For the grass cutter project, simple stack machine instruction set architecture, or an accumulator will not work for the in-depth coding required for path planning in the obstacle avoidance system. The complexity of cache sizes and compilers required to carry-out the needed complex instructions may also result in the need of more memory space on the development board. Choosing a microcontroller from the previous section or one already located on a development board handles the interfacing compatibility challenges of designing a development board from scratch. Instead, the already built software and compilers that are

designed to assure correct code implementation may be used for test running potential parts.

3.1.5 Motor Technology

DC motors are analyzed and researched to obtain appropriate wheel torque and blade torque. DC motors are constructed using field windings and an armature. Armature windings have current running through the conductive material used. The different ways to carry-out the practice of using polarities and windings to initiate motor rotation is summarized in this section. The brushed DC motors and brushless DC motors will be described in section 3.1.5.2. of the document. Motor control and different rotating motor methods will be explained first.

3.1.5.1 Motor Control

The overall motor control can be resolved provided the use of a microcontroller and motor drivers. The idea of motor drivers is to take in signals from the processed microcontroller unit sensors and Computer Vision application. The signals are then amplified to drive an electrical current to the motor load. The amplified current drives through the armature windings of the DC motor creating the potential voltage needed for the motor to begin turning. The direction of the current or the voltage polarity across the load can control the direction of motor rotation. The practice of these concepts will control the direction and speed of DC motors for the grass cutter project.

3.1.5.1.1 H-Bridge PWM Driver ICs [9]

H-Bridge configurations are capable of bidirectional control of DC brush motors. The H-Bridge is in the shape of an “H”. This is because it has four drivers making the upper and lower vertical lines on either side in conjunction with the motor on the horizontal bar in the middle. It uses Pulse Width Modulation (PWM) control that is used to regulate the DC motor’s speed, torque and position. It includes forward, reverse, coast and brake modes, and slow, fast and mixed PWN decay modes [10]. These are useful for full functionality of the DC motors. The simple ‘H’ shaped circuitry described to control speeds and direction will also require additional circuitry in the IC for protection. Protection circuits for the H-Bridge drivers include overvoltage protection, under voltage lockout, Overcurrent protection, thermal shutdown, Overlap or ‘shoot-through’ protection and high electrostatic discharge protection [10]. Therefore, the circuitry in the IC is not as easily built as a simple ‘H’ design. Digital logic inputs need a control unit for processing signals that are dispersed accordingly. The digital logic control unit is used to control the MOSFET switches in the H-Bridge circuit, providing options of the motors turning direction, speeds, and braking. The protection circuits are typically connected to the control unit.

The ‘shoot-through’ or overlap case occurs when and if all switches become in the closed position at once. This could occur when the MOSFET gate voltage values are changing the allowed current flow through the device. In the case of overlap, the current will flow through all the closed MOSFET switches of the H-Bridge circuit delivering nothing to the

motor load. Overlap is not desired for efficiency of the source when current is being provided for no reason. Also, undivided current may become too high and damage components in the circuit. To protect the circuit from the shoot-through case from happening, an amount of time must be inserted between switching occurrences to allow for the MOSFETs in the circuits to fully come to a closed or open position before the next input voltage becomes active in the circuitry.

3.1.5.1.2 Dual, Full-Bridge PWM Motor Driver ICs [11]

Dual, full-bridge Pulse Width Modulation (PWM) motor driver ICs can independently operate two separate DC motors using the same H-Bridge MOSFET methods described in the above section. The typical applications these are used for are brushed DC motors, brushless DC motors and Stepper motors. The IC chips are designed to accept logical input voltages for switching controls that drive inductive loads. For PWM current control, they have capabilities of selecting the maximum output current of a reference voltage and sensing resistor. Two logic-level inputs can be selected of the current limit percentage from 0 to 100 percent. The phase input to each full-bridge determines the direction of the load current. These types of motor drivers usually have high efficiencies in the range of 90 to 96%.

3.1.5.1.3 Motor Encoders [12] [13]

Motor encoders are used to set perimeters of speed and position control for electrical motors. Encoders sense mechanical motion and produce digital signals. There are two different types of encoders, linear and rotary. Linear encoders sense and detect speed on a specified path while rotary encoders read speeds of circular paths. Essentially, the encoders work in two ways. One way is defined as incremental; the incremental linear or rotary speed identifying method uses opaque grooves in a line or disk [13]. Photo sensors are implemented with the use of light emitting diodes to sense the groove patterns that are equally spaced apart in the material. As the disk rotates, pulses are generated from the sensors that sense each groove [13]. Each revolution's generated pulses are recorded to derive speed of the unit. Linear encoders make use of sensors. The sensors are linked to a scale for reference to locate exact position. After the scale is read by the sensors an analog or digital signal is produced. These signals are converted to a digital output that can sense movement using the distance and timing changes of the digital output [13].

3.1.5.2 Types of DC Motors

The type of DC motors chosen are vital for the overall motion and cutting of the system. There are a variety of DC Gear Motors in the market today. The crucial specifications in picking what kind of DC motor will be focused on low power consumption, high torque and low speed. For the string-based blades, the DC gear motor will need a considerable amount of torque and a speed of around 3000 rpm to efficiently cut the grass. For the front wheels, it will need a considerable amount of torque and a speed of around 2000 rpm to efficiently maneuver the grass cutter through uneven terrain. Table 13 below shows the comparison of different DC motor types.

Table 13: DC Motor Types Comparison

	DC Brush Motors [14]	DC Brushless Motors [15]
Key Elements	<ul style="list-style-type: none"> -Simplified wiring -Can be wired directly to DC power -Can be controlled as a simple as a switch -Lower costs -Electrically noisy -Less lifespan due to shaft, brushes and commutators wear out -Typically, 75-80% efficient 	<ul style="list-style-type: none"> -Longer lifespan due to no brushes to wear out -Low maintenance due to no brushes needing replacement -High efficiency -High initial costs -Needs commutating device such as an encoder and a drive or controller -Typically, 85-90% efficient

3.1.5.2.1 DC Brush Motors [14]

DC Brush Motors are one of the most popular types of motors to use because of their simple drive control options and relatively low costs. It has a simplified wiring that can be directly wired to DC power such as a battery. It can be controlled as a simple as a switch. The disadvantages are that they are electrically noisy, have lower lifespan due to the shaft, brushes and commutators wearing out, and only 75-80% efficiency. Due to the lower costs, it is more ideal. It does not need an encoder and a drive or controller. They contain a rotating electromagnet that is surrounded by a permanent magnet. This pair creates a rotational torque that is produced from the interaction of the magnetic fields. This is done by the continuous rotation that is produced from the change of polarities of the rotating coils with the mechanical brushes and commutator. They come in a variety of configurations such as Half and H-Bridges. A Half-Bridge configuration is for single direction operations. A H-Bridge configuration is for bi-directional operations. Figure 10 below shows the diagram of the construction, working principle and operation of a Brushed DC Motor.

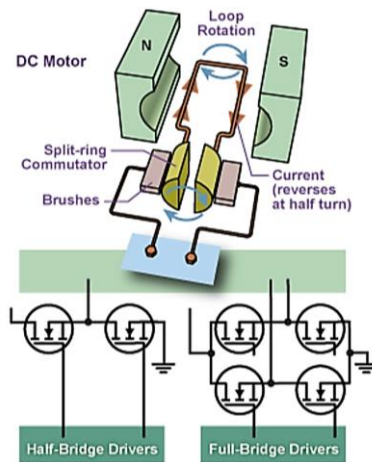

Figure 10: Brush DC Motors Diagram used with reference from Allegro Micro Systems [14]

3.1.5.2.2 DC Brushless Motors [15]

DC Brushless Motors, also known as electronically commutated motors, can provide higher efficiencies, lower power losses, improved reliability, and excellent torque-to-weight properties. The advantages of this motor over other DC motors are it has no mechanical commutator and the associated problems with them, has high efficiency of 85-90% because of the permanent magnet rotor, long life span with no inspections and maintenance required, and high speed of operations despite the load conditions. The brushless motors are not noisy or have any limits of speed due to the absence of brushes. They have less electromagnetic interference, weight and smaller motor geometry. These motors have some disadvantages of not being cost-efficient, an electronic controller is required to control this motor, requirement of complex drive circuitry and needs additional sensors to operate. Although this motor would be ideal for this project, it is not feasible due to the limited budget and resources. Figure 11 below shows the diagram of the construction, working principle and operations of a Brushless DC Motor.

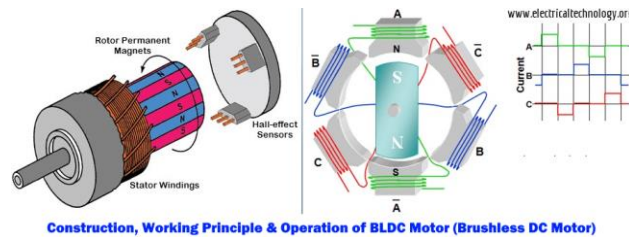

Figure 11: Brushless Motors Diagram used with reference from electricaltechnology.com [15]

3.1.6 Voltage Regulators

Voltage level control within different hardware components for a system is crucial. Voltage regulators create fixed voltage amplitudes as an output regardless of changes made to a present input voltage. In nearly every electronic there exists a voltage regulating building block that is easily used to control a power supply. Voltage regulators IC circuit are inexpensive and are, almost always, compatible. The two types of voltage regulators are linear and switching voltage regulators. In Table 14 below, the types of Voltage Regulators are compared.

Table 14: Voltage Regulators Comparison

	Linear Voltage Regulators [16]	Standard (NPN) Regulator [17]	LDO Regulator [18]	Step-Down Converters [19]
Key Elements	-Uses voltage controlled current sources -Uses BJTs or MOSFETs -High efficiency	-Uses a pass NPN BJT -High current gains -Ground pin current is ineffective regarding efficiency	-Lower dropout voltage -Potential voltage is fully utilized -Ground current is the highest and wastes power	-DC-to-DC converter -Great for regulating power from batteries -Operates at max 150kHz and 3 Amps -High Efficiency

3.1.6.1 Linear Voltage Regulators [16]

According to Chester Simpson, a member of Technical Staff in power management applications at Texas Instruments, a control loop operation can give detailed visualization as to how typical linear regulators are implemented [16]. The control loop that is used to construct the most common types of voltage regulators consists of a circuit with a 'pass device' in the beginning that allows current to pass through once then remain trapped in a loop. Additionally, an error detecting amplifier, two sensor resistors and a load are also components that are used in the controlled loop operation. The pass device is where the initial input voltage is accepted into the circuit. After the initial voltage is inputted and the source is passed through an initial transistor, this current is no longer about to pass back through that first transistor. Voltage potentials are divided through resistors that create and sense a reference voltage.

Linear voltage regulators are used with a voltage controlled current source that is controlled through two resistors to provide a desired reference voltage. With use of bipolar junction transistors (BJTs) or MOSFETs, current is looped through an 'error amp.' The error amplifier in the IC accepts a voltage reference as well as low input current, the current is low and the resistance on this line is in parallel to a load line. The amplifier's input impedance is significantly higher than the reference voltage line impedance. With high input impedance inside op amps, little current can enter the amplifier. Furthermore, there exists two resistors on both sides of the voltage reference. These resistor values divide the voltage between the output voltage and the reference voltage. The load line and the amount of load current on the line is not what controls the voltage output of the regulator. The reference voltage being multiplied by the amplifier gain in the feedback control loop is what manages the output. If input voltage changes, a transient response is required for the error amplifier to fix the voltage back to a specifically engineered amount delivered to the output. Sense the resistors on the reference line initially divide the input voltage and have a ratio to the load line resistance as well as the internal amplifier resistance, many linear voltage regulators cannot accept any voltage input amount. An interval of input voltage can be accepted. If an input voltage does not meet the range of allowed input amounts, then two regulators in series having different internal impedance values may have to be used to fully break down voltage levels.

Research on three different types of linear voltage regulator circuits can generally explain how regulators work. These basic voltage regulators can be further modified if more complexity is needed in the circuitry for the electrical design of the autonomous grass cutter project. Modified output voltages are feasible with these regulators. The three types include the standard NPN regulator, the low dropout (LDO) regulator, and the Quasi-LDO regulator. The most important difference between the three types of linear voltage regulators is the dropout voltage that relates to efficiency. Three or four voltage regulators will be needed in the grass-cutter project for drop down or step-down voltage purposes. The dropout voltage can be described as the minimum voltage drop required across the regulator required to regulate the output of the IC. The larger this dropout voltage gets, the less efficient the circuit is. The LDO regulator requires the least amount of a dropout voltage and saves the design on efficiency this way. The standard regulator requires the

highest amount of dropout voltage and is less efficient in this manner. Even though the dropout voltage is a contributing factor of the overall efficiency, there exists a ground pin current factor as well. Trade-offs between the regulators are analyzed to determine which type of regulator may be a better choice. The ground pin current takes amperes produced from a source and grounds the current, wasting power. The higher the ground pin current, the less efficient the IC becomes. The standard voltage regulator has the lowest ground pin current with the highest dropout voltage and the LDO regulator has the highest ground pin current but a lowest dropout voltage. These trade-offs should be recalled as further demonstration of the different voltage regulators designs are discussed in this section.

3.1.6.2 Standard (NPN) Regulators [17]

The standard regulator uses a pass NPN bipolar junction transistor internally. For the manufacturer of this semiconducting device to guarantee operation, a specified voltage interval is requested to be, typically, between 2.5V and 3V (standard). Depending on the manufactured model of a standard regulator, provided datasheets can explain a temperature margin required for the IC to operate as intended. The standard regulator has the highest dropout voltage due to these transistors requiring a minimum amount of voltage for current control. The dropout voltage amount can be calculated using the base-emitter voltage and the collector emitter voltage required in each transistor to activate the device. Three transistors are used in the standard regulator; one PNP junction and two NPN junctions. Additionally, the current gains are extremely high in the standard regulator IC. Therefore, the ground pin current is so ineffective regarding efficiency.

3.1.6.3 Low Dropout (LDO) Regulators [18]

The low dropout regulator maintains a lower dropout voltage across a single PNP transistor. Battery operating applications use this type of voltage regulator more frequently than others because of the potential voltage needed is fully utilized. Ground pin current in this type of regulator is almost equivalent to the load current divided by the gain of the PNP transistor. Therefore, of the three types of linear voltage regulators the ground current for this type is the highest. This will be used for the application of converting 5-Volts to 3.3-Volts on the ATmega2560 implementation on the custom-made PCB design.

3.1.6.4 Step-Down Converters [19]

The buck converters, also known as step-down converters, is a DC-to-DC converter that will step down the voltage from the battery to the components. This is an important technology that will be used in this project. It is ideal for regulating the power from the battery to the components. It can handle the 12-Volt batteries that will be used in this project. The electrical components will have their own power supply in which they will have to be stepped down from 12-Volts to 3.3 to 5-Volts. A popular technology is using the LM2673 step-down voltage regulator. The LM2673 will be used for this application of converting the unregulated 12-Volt battery voltage to a regulated 5-Volts to the electrical components on the custom-made PCB design.

3.1.7 Switches Technology

Switches technologies in electrical circuits are designed for different purposes. Having a manual switch or ‘hand switch’ as an emergency kill switch for the entire system would be a safe decision to assure there is always a way to shut down the grass cutter when the 50-foot wirelessly transmitted kill switch is out of range or malfunctioning. When the term manual switch or hand switch is used to describe a switch in this text, it is intended to state that these described switches will not be constructed with the use of any semiconducting technologies. The idea of a manual switch is that physical contact is required to move the position of the switch either by pulling, pushing inward, rotating, or sliding a physical component. Some manual switches frequently used in current technologies are manufactured as different switch types. Although there exist many types of ‘hand switches,’ only relative and convenient types of switches that may be necessary in the autonomous grass cutter project will be mentioned. Three different hand switches with their schematic representations are provided below alongside a ‘speed switch.’ The speed switch is different in a way that it is not a manual switch; it is a process switch that can use sensors to indicate speeds of mechanical components. [20]. Table 15 below compared the different types of kill switch technologies.

Table 15: Switches Technology Comparison

	Pushbutton Switch [21]	Toggle Switch [22]	Selector Switch [23]	Speed Switch [24]	Diode Switch [25]
Key Elements	<ul style="list-style-type: none"> -Can have red LED light -Cost ranges from \$2.50 to \$5.00 depending on size. -Implements by pushing switch inward, changing ON/OFF for each inward push. 	<ul style="list-style-type: none"> -Level Connected switch. -Two options, two physical directions -Cost range from \$1.00-\$26.00 depending on quality and size. 	<ul style="list-style-type: none"> -Can have three or more option modes. -Low, Medium, High Modes -Cost range of \$10.00 – \$26.00 	<ul style="list-style-type: none"> -senses speeds in rpm to protect machinery -activates from 0.3 rpm through 25000 rpm -Costs ranges from \$38.00 to \$45.00 -Can measure belt speeds 	<ul style="list-style-type: none"> -Uses voltage potential to logically create 4 outputs -Not as energy efficient as other switches -uses ground to initiate OFF switches -Costs less than \$3.00

3.1.7.1 Toggle Switches [22]

The toggle switch is commonly used in house hold lighting switches. This type of switch is actuated by a lever connection at an angle. The lever is commonly at an angle representing an open circuit with a closing possibility. In general, the toggle switch

positions come to rest at a one of two available position settings but sometimes can connect to a wire when in the 'open' position. The toggle switch does not always have to come to rest in a position. A spring load can be added to return the altered connection of the toggle switch to a desired 'normal' position. This type of switch may be considered as a possibility for a manual kill switching mechanism located on the solar farm grass-cutter in case of remote kill switching not operating properly.

3.1.7.2 Pushbutton Switches [21]

Pushbutton switches can be actuated by two positions, either in the 'pressed' position or the 'out/pulled' position. Some pushbutton switches are implemented with an internal spring force returning the pushbutton to the 'out' position. This type alternates the connection with every push-in and release physicality used together [1]. Each time the button is pushed and then released the unit creates an alternate an 'on' or 'off' output while returning the button to the 'out' position. The other way these pushbutton switches are constructed is without an internal spring load. The switch comes to rest in the 'pressed' position and the 'out' position. Typically, when pushed in the switch is in the closed position and when pulled out the switch is open.

3.1.7.3 Selector Switches [23]

Selector switch use a rotary lever (like a stove top dial) [1]. The rotary lever switching mechanism acts like the toggle switch. A spring load can be inserted to force the lever to return to a normal position for momentary operations. Many different selection options can be chosen within the circumference a knob by using this type of switch.

3.1.7.4 Speed Switches [24]

Speed switches are not manual switches but may be useful as an internal kill switch. The switch actuates when the rotary speed of a shaft reaches a preset level that can be detected by a sensor. If a shaft is rotating at a dangerous speed, the switch can shut down the machine avoiding destructive or hazardous accidents. There can exist more than one kind of sensor within a speed switch. The sensor can detect shaft speed optically or magnetically [1]. Speed can also be measured with a centrifugal weight mechanism if mounted onto the shaft. Speed switch applications may be useful when prototyping the autonomous grass cutter's blade motor for safety purposes.

3.1.7.5 Diode Switches [25]

Other switching designs include semiconducting devices such as MOSFETS and diodes. At a specified potential voltage, current can flow through the device creating a closed-circuit schematic. At lower voltages than the specified amount the device acts as an open circuit and current may not flow through. Diode circuits can uniquely be used as switches using more than one input for output direction. Diode circuits can perform digital logic fundamentals that introduce options of having a switch activated in a case of numerous events happening simultaneously. Logical operands being fashioned using diodes and

switches can implement two or more input signals. AND logical gates, as well as OR logical gates can be designed using the diode circuits with toggle switches on the lines. An output signal is obtained using two inputs provided by the internal diodes when the input voltage is above an estimated 0.7 Volts.

In consideration of inductive sensors which may be used for detecting perimeters on the autonomous grass cutter, the voltage processed for each sensor can possibly control current flow through a MOSFET. MOSFET devices can be used as the switches. With MOSFET gates being activated by potential voltages from sensor signals, logical operands can be implemented and can accept more than one sensor signal at a time. These diode switching circuits provide many switching capabilities and control over more than just one input. The manual switches mentioned previously only use one input generally shutting off or disconnecting all or one motor at a time (one chosen output). Diode switching circuits can deactivate and reactivate different motors autonomously based on sensor inputs or inputs from any other processor involved in the navigation system.

3.1.8 Programming

An appropriate programming language that fits the projects unique requirements must be chosen. To select a programming language, some of the factors considered are the length of the code as well as the runtime of the code itself. It would be best to use a language that optimizes the use of the hardware. However, if one piece of hardware needs to communicate with another by sending interrupt signals, the complexity of the code may get long. The problem with lengthy code relates to the amount of flash memory required versus the amount provided on each piece of hardware. While the mower is turned on and in operation, coding interrupts must be running continuously in order to detect and avoid obstacles. The rate of these interrupts does not have to be faster than the source code itself. Furthermore, the interrupts can be ideally slow compared to the program awaiting an interrupt signal. This way, the delivered interrupting signals can be inputted at a rate that is energy efficient and have time to decode image inputs. By running at a slower rate, the CPU will require less work at any given clock rate that is higher than that of the CV program, perhaps. Signals sent to hardware through either sensors or computer vision must be directed to a designated pin location. Once these locations hold a voltage potential, interrupts in the programming code must check for the inputs then cease operations in the primary code and use alternative coded methods to control the motors. Secondary code, or other pieces of code in hardware components, are designated greater hierarchy over the primary code that runs the grass-cutter in a forward position. The hardware codes will interrupt and execute to avoid obstacles. Whether an input signal is received into hardware from the computer vision application or a sensor application, the robot should avert away from whatever obstacle the grass-cutter may be approaching. If the avoidance coding system fails to avoid an obstacle in the first cycle of an interrupt program, then the avoidance signal remains 'on.' The system program must continuously check whether an obstacle remains in the path. Many of the programs involved with the control of the autonomous grass-cutter consists of assembly code for each piece of hardware. In addition to the basic hardware coding, a Raspbian Pi development board can also make use of Java and C++ coding applications that regulate picture imaging for a computer vision program.

With the capability of hardware linking to a Windows or Linux operating system, C-Code as well as any higher language program can be implemented to send and receive signals. The programming techniques and applications used in the grass-cutter project must make every decision regarding the robot's path. Blade motor operation control decisions are also predicted and decoded. In Table 16 below, the comparison of different programming languages and libraries.

Table 16: Programming Languages and Libraries Comparison

	C [26]	Python [26]	C++ [26]	OpenCV [27]
Key Elements	<ul style="list-style-type: none"> -Structure-Oriented -Middle-level programming language -Used to develop low-level applications -High memory management -High syntax to support abstract data types -Most device drivers are developed using C 	<ul style="list-style-type: none"> -Advanced programming language -Object-oriented -Built on flexible and robust semantics -Faster by integrating systems as a scripting or glue language -Simple to learn and easily read 	<ul style="list-style-type: none"> -Object-Oriented -Middle-level programming language -An extension of C language -Quick processing and compilation mechanism -Robust standard library (STL) -Specializes in embedded firmware and client-server applications 	<ul style="list-style-type: none"> - Open source computer vision and machine learning software library -Has over 2500 optimized algorithms -many advanced algorithms used in image processing -Algorithms include detecting, identifying, tracking, and classifying objects/humans

3.1.8.1 C Programming Language [26]

C is a middle-level programming language usually used to develop low-level and system applications such as graphics packages, spreadsheets, word processors, compilers, assemblers and operating system development. The C language can be used to support many technical needs and is compatible with the Raspberry Pi and Arduino boards. One problem with the C language is its lack of support for higher ordered data structures. Memory management is a crucial element to pay attention to in this language. It requires high syntax to support the abstract data types. Developers should efficiently write the code to avoid degenerating the system and creating long runtimes. This is beneficial to this project due to the high capabilities with the components that will be used such as ATmega2560, motor driver chips and ATmega16U2.

3.1.8.2 Python Programming Language [26]

Python is an advanced programming language that can be used for many applications. This language is used to develop applications such as Rapid Application Develop (RAD) and web-based applications. It is better known for their libraries such as SciPy and NumPy.

Python is an intuitive language that can be used to write fast code with little experience. It is built on flexible and robust semantics. It is faster due to the integrating systems as a scripting or glue language. It is very simple to learn and easily read. This is beneficial to this project due to the high capabilities in Raspbian Operating System. It can be used in conjunction with C++ on the Raspberry Pi.

3.1.8.3 C++ Programming Language [26]

C++ is a middle-level programming language that is an extension of the C language. It is used to develop applications such as computer programs, packaged software, games, office applications, video editors and operating systems. The same applications apply to the C language. The C++ language can be used to support many technical needs and is compatible with the Raspberry Pi and Arduino boards. It has a robust standard library (STL) and a quick processing and compilation mechanism. This is beneficial to this project due to the higher performance and high capabilities with the components that will be used such as the Raspberry Pi and camera.

3.1.8.4 OpenCV [27] [28]

OpenCV is an open source computer vision and machine learning software library that provide over 2500 optimized algorithms. This includes applications such as detecting, identifying, tracking and classifying objects/humans. It supports operating systems such as Windows, Linux, Android and Mac OS. Programming languages such as C++ and Python are supported which are ideal for this project. This library will serve a very good purpose because being open source will allow the use of any existing code without the legal repercussions associated. There is a lot of overhead with re-writing algorithms that can be called with a simple API call. This framework can be used to help the robot make informed decisions associated relating to its driving subsystem.

One use of open CV for this project is to detect objects in the range of the robot. There are many useful ways to do this, and one method is to use an edge detection algorithm. To simply put, an edge detection implements the idea of finding the edges of an image by taking the gradient of the image in the vertical x, or horizontal y direction pixel by pixel and finding their respective magnitudes. By finding an image gradient, the edges of an image can be found because there will be a jump change of pixel intensity on an edge. Canny edge detection is a very useful algorithm that can also be found on OpenCV. Canny edge detection goes through a 4-step process to find the edges of an image and is shown below in Figure 12 [28].

- 1. Noise Reduction with Gaussian Filter**
- 2. Finding Intensity Gradient of the Image**
- 3. Non-Maximum Suppression**
- 4. Hysteresis Thresholding**

Figure 12: Canny Edge Detection Process

Although this technique is powerful, this is only one step in the bigger picture of a neural network. OpenCV is a very valuable library that will be used in this project for all the computer vision, machine learning and image processing algorithms needed.

3.1.9 Obstacle Avoidance Sensors

Obstacle Avoidance Sensors are vital to this project. The grass cutter must be capable of avoiding all obstacles, objects, humans and infrastructure. It must not damage any surrounding environment or infrastructures such as the Solar PV Panels and PV Structures. There are various technologies that can be used such as Ultrasonic Sonar, LiDar and Infrared sensors. This will be described in the following sub-chapters.

3.1.9.1 Ultrasonic Sonar Sensors

Ultrasonic Sonar sensors, also known as proximity sensors, determines the distance to an object by measuring the time lapses between the sending and receiving of the ultrasonic pulses. This is done by using a single transducer to send a pulse through the trig pin and receiving the echo through the echo pin. When an object is in its line of sight, the signal will be received back to the sensor. If there is a clear path, no signal will be received. The distance of how far the object is measured by the time it takes for the signal to come back. This is calculated using the frequency and wavelength of the sound waves. This system works by sending out high frequency sound waves that reflect from boundaries to produce distinct echo patterns. The Ultrasonic sound vibrates at a frequency above the range that a human can hear. These sensors can be used in any environment whether it is light or dark, inside or outside. They handle lots of movement and vibrations well. Common applications that they are used for are presence, level, position and distance. An advantage is that they work well in dark, smoky, misty and foggy areas as well. A disadvantage of the ultrasonic sensors are they do not do well against soft surfaces such as cotton or wool. Those surfaces absorb the sound wave instead of reflecting them. These sensors are reliable, feasible, accurate, low-cost, and effective for distance sensing, obstacle detection, obstacle avoidance and leveling.

3.1.9.2 Lidar Sensors

Lidar is a remote sensing technology that use pulses from lasers to collect measurements. These measurements can be used to create useful information such as 3D models and maps of the surrounding environment, objects and obstacles. Lidar works in a similar way to Sonar but uses light waves from lasers instead of sound waves. It calculates the time it takes for the light wave to hit an object and reflect to the scanner. This is calculated using the velocity of light and time of flight measurements. Intelligent Lidar systems can fire an average of one million pulses per second. The measurements data can then be utilized and processed into 3D visualization that is also known as point cloud. Lidar is very effective in navigating autonomous vehicles. Although Lidar could bring tremendous amounts of elements to improve the mapping and navigation system of this project, Lidar systems are not cost efficient; they are very expensive relative to infrared and sonar systems.

3.1.9.3 Infrared Sensors

Infrared sensors on the principle of reflected light waves. The light waves are reflected from the object that may be in line of path that is used to estimate the distance between them. The disadvantage is the infrared sensors cannot work in dark environments. They are sensitive to dark surfaces and dark lighting. An advantage over other sensors is that although they can detect motion, they also have the capabilities of measuring the emission of heat by an object. This is a useful element for the robot not to go into areas that are too hot that might damage the system. Although this may be useful in a Solar Farm, it is not ideal due to the budget and resources of this project.

3.1.10 Operating Systems

The use of an operating system will play a crucial role of the software system to run Computer Vision on the Raspberry Pi Development board. The options that could be used are Windows, Linux or Raspbian Operating System. After extensive research, Raspbian would be the best Operating System for this project's applications. The Raspbian would be most compatible with running algorithms for OpenCV.

The Arduino ATmega2560 will be used in conjunction with Windows Operating System. It was decided a Windows Operating System would be the best programming environment to work in to load the code into the microcontroller.

3.1.11 Perimeter Boundary Wire [29]

An autonomous vehicle and the methods used to control its direction can be done using a perimeter wire. A wire enclosing the desired area to be mowed can be detected by a sensor. Through signal processing at a specified frequency inside the wire, an electromagnetic field can be detected using an inductive sensor that is to be located on the mower. The same concept is used frequently today for maintaining a perimeter for pets. A sensor is placed in the pet's collar that reacts to the electromagnetic field around the wire. The convenience of using a perimeter wire gives the user an exact boundary of the grassy area that needs maintained. Obstacles within this boundary can be detected and avoided using computer vision that will be discussed in section 3.1.2.6. However, the boundary can be difficult to declare by using a camera that detects objects as well. For the CV system to differentiate between a boundary and an object, the configuration method to distinguish a difference may get too complex for the programmer. This leads to a perimeter wire being a constructive tool to be considered as the mechanism keeping the autonomous grass cutter inside a given square footage of are.

An integrated precision circuit timer, the NE555 (or 555), is an integrated circuit that can be used to control the resonance frequency in the wire. The same chip can be used as a pulse generation or an oscillator as described and manufactured by Texas Instruments. The signal can be a digital or analog, the frequency may alter minorly and this can be accounted for. The IC can be used to generate a rough square-wave that is ran through the entirety of the wire. Reactive components are easily added to the IC to produce the desired frequency

of the signal in the wire. The receiver sensor should be made using an LC circuit allowing the voltage in the wire to be transmitted at the same frequency. When the sensor on the grass cutter approaches the wire, the amplifier in the sensor should have a high enough gain to amplify the signal high enough to pass current through a diode. The signal is then processed on the microcontroller board where a decision is to be made for the navigation of the robotic machine. This constructed example is just one ideal way for a sensor to transmit the signal when approaching the wire.

This is an ideal approach for setting boundaries for the grass cutter project at hand and is easily implemented. However, the wire perimeter will require more preparation along with a generator circuit that requires its own power supply. In preparation of the wire, a weather proof coating should surround it to assure no deteriorating can occur. Shielding the perimeter wire may reduce the electromagnetic field induced around the wire as the current passes through it. This reduction in the radius of the field may lessen the distance in which the sensor detects the boundary wire. Sense alternative wire shielding techniques may fluctuate the range of detection, the chosen shield radius must maintain a minimum electromagnetic field voltage that the sensor can detect at a reasonable range.

As for the mentioned generator circuit. The circuit's responsibility is to maintain current at a given frequency value. The generator circuit requires a power supply as well. Goals of the project consists of eliminating costs and maintenance. If the generator is dependent on a battery that needs replaced periodically, this would increase the cost and influence the overall efficiency of the project. The generator may need to be surrounded with a weather proof casing as well given that the area of vegetation needing maintained has no shelter nearby. This system is capable of being configured to drive on the boundary line, drive beside the boundary line and not to go on a certain side of the boundary line. As shown below in Figure 13, the Perimeter Wire Generator Circuit will produce a square wave output that the Perimeter Receiver Circuit will receive. Figure 13 is referenced with permission from Robotshop.com.



Figure 13: Boundary System Diagram used with Permission from Robotshop.com [29]

3.1.12 Wireless Communications [30]

Wireless communications are a key element to implement into the project because wireless communications can enable an established method of sending inputs and receiving outputs between the autonomous grass cutter and other peripheral components. Wireless communications can enable features such as, boundary zone implementation, operating system application, video streaming, and remote control of the autonomous grass cutter. Wireless Communications can be used to fulfill a customer requirement of a kill switch with a range of at least 50 feet using an established communications link between the autonomous grass cutter and an operating system application. For example, a remote kill switch function can be implemented by sending a “kill” command from an operating system application to the autonomous grass cutter via an established wireless communications link. The “kill” command would ultimately be received by the microcontroller to then proceed into a shutdown procedure. It is also possible to program the autonomous grass cutter to send signals to an operating system application to output statistical data such as GPS location, battery information, troubleshooting information, and operating statistics. Modern wireless communications consist of mostly two standardized protocols; the IEEE 802.11 specification of wireless local area networks (LANs), also known as Wi-Fi™, and Bluetooth.

3.1.12.1 Wi-Fi™ [30] [31]

Based on the IEEE 802.11 standards, Wi-Fi™ is a radio frequency technology used for wireless local area networking (WLAN). There are multiple versions of the 802.11 standard where each version has its own name, denoted by the standard version, and specifications. Modern Wi-Fi™ most commonly uses 2.4 gigahertz (UHF) or 5.8 gigahertz (SHF) radio bands. Table 17 below lists the most commonly used Wi-Fi™ versions used and the capabilities that will be compared for selection.

Table 17: Wi-Fi™ versions suitable for autonomous grass cutter [31]

802.11 Protocol	Stream Data Rate (Mbit/s)	Outdoor Range
802.11b	1, 2, 5.5, 11	140m (460ft)
802.11g	6, 9, 12, 18, 24, 36, 48, 54	140m (460ft)
802.11n	Up to 288.8	250m (820ft)
802.11n (5 GHz)	Up to 600	250m (820ft)

The highest range wireless versions, 802.11b, 802.11g and 802.11n were chosen to be compared over versions that are capable of higher data rates because most of the data sent, whether it is for a kill switch or an operating system application, will most likely be parameters from the autonomous grass cutter and not something data intense, such as video streaming (although it may still be capable of video streaming). Each version has a specified frequency and range. A most likely case for this project is that the autonomous

grass cutter will be transmitting and receiving on a 2.4 gigahertz (UHF) radio frequency band, unless 5.8 gigahertz (SHF) is chosen under the 802.11n version.

Since Wi-Fi™ creates a wireless local area network (WLAN), it is possible to connect the created local area network (LAN) to a metropolitan area network (MAN) or wide area network (WAN) and establish communications to the autonomous grass cutter from remote locations as far as from the other side of the world. The one caveat to the previously mentioned scenario, however, is that additional networking equipment will be required. It is doubtful that the WLAN created for the autonomous grass cutter will connect to a WAN or MAN through the solar farm’s networking equipment as network security problems could arise or the solar farm could simply not support outside internet access. However, using the WLAN created for the autonomous grass cutter, other devices can connect within a range of 140 to 280 meters. Since the kill switch requirement is of at least 50 meters, using a kill switch implemented with Wi-Fi™ will meet the requirement.

3.1.12.2 Bluetooth [30]

Over recent years, Bluetooth has become more accessible in applications requiring a personal area network (PAN). Spun off from IEEE wireless standards, Bluetooth uses 2.4 gigahertz (UHF) radio frequency to transmit and receive. Although Bluetooth is a great low power solution for wireless communication, Bluetooth only allows for a maximum range of 10 meters in most cases. There is a class of Bluetooth capable of 100-meter range, but the technology is too expensive when compared to the cost of Wi-Fi™.

Since the Bluetooth transceivers within the project’s budget have of range of typically 10 meters and the customer’s kill switch requirement is of at least 50 meters, Bluetooth would not be an acceptable technology to use for implementation of the kill switch. The range limitation of Bluetooth provides a significant drawback even when considering that Bluetooth consumes less power than Wi-Fi™. Table 18 below shows a comparison between Wi-Fi™ and Bluetooth.

Table 18: Wireless Communications Comparison [30]

	Wi-Fi [30]	Bluetooth [30]
Key Elements	<ul style="list-style-type: none"> -Operates at 2.4-5 GHz -High Cost -Up to 11Mbps bandwidth -600Mbps Bit Rate -High Power Consumption -High Range 	<ul style="list-style-type: none"> -Operates at 2.4GHz -Low Cost -800Kbps bandwidth -2.1Mbps Bit-rate -Low Power Consumption -Low Range

3.1.13 I²C Protocols [32]

To communicate devices with a microcontroller, one might use the I²C communication bus. This technology is very popular and used in many designs due to the nature of its simplicity. The I²C communication bus is widely used and easily allows projects to adapt with ease. Conceptually, the I²C protocol is used when a master device is used to

communicate with a slave device, or many slave devices. This is unique because only two wires are needed to implement communication between these slave devices and their master. These two wires can be used to communicate up to 128 different slave devices with 7-bit addressing, or 1024 with 10-bit addressing. The two wires are named Serial Clock Line (SCL) and Serial Data Line (SDA). The data line will contain the ID of the device to be communicated, packed in a series of 8-bit sequences. This will allow the master to communicate with any device. The SCL is use as the clock signal and is synchronized with the master device and synchronized with the data transfer bus. These two wires are typically open joined, which means it will require pull up resistors to function, because the wires operate on an active high, whereas each device along the I²C bus will operate on active low. The I²C bus configuration is shown below in Figure 13.

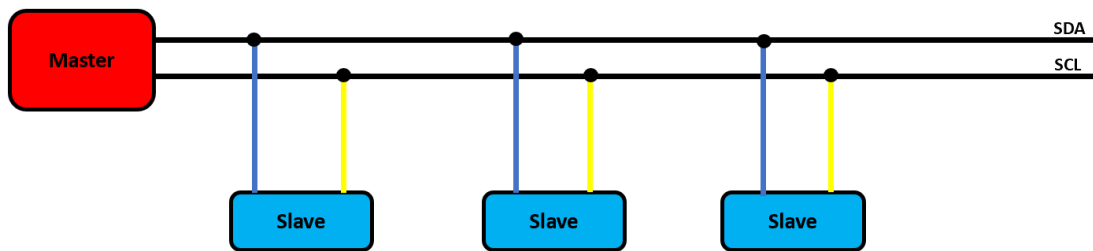

Figure 14: I²C Bus Configuration made by Mario Mcclelland

The image in Figure 15 below represents the sequence at which a packet of data would be transmitted from a master device to a slave device. Here you can see it starts off by transmitting the address at which the slave is located, then it will access any internal registers within the slave module, and lastly transmit or receive the data. Acknowledgement bits are used to indicate successful transmission, as well as indicating an end to the data transmission. This can be done bi-directionally along the line for communication between both master and slave. The bit fields of data transmission on an I²C bus is shown below in Figure 15.



Figure 15: Bit fields of data transmission on an I²C Bus made by Mario Mcclelland

3.1.13 SPI Protocols [33]

Serial Peripheral Interface, better known as SPI was introduced by the company Motorola. SPI is used to communicate a single master device and it will output to many slave devices. Using the SPI protocol on an Arduino is very simple. There are four wires used to implement this communication system and they are as follows. First wire is SCK or Serial Clock wire, this is the wire that propagates the clock signal from the master device. The second wire is MOSI, which is Master Out, Slave In this wire is used as the output from the master device and an input to the slave device. The MISO line, or Master in Slave Out is used as input to the master, and output from the slave device. The last wire is the SS or, Slave Selection, this wire will send the signal to the slave that will be selected for data transmission.

3.1.14 UART [34]

UART stands for Universal Asynchronous Receiver/Transmitter. It is not a communication protocol like SPI and I²C. It is a physical circuit that is implemented inside devices such as microcontrollers and stand-alone Integrated Circuits (ICs). It can be applied to applications through hardware such as transmitting and receiving data. This integrated circuit can transmit serial data between two UART devices connected to each other. UART does not rely on a clock signal to transmit data, therefore it needs another way of indicating when to begin and end data transmission. In a UART signal, there are start and stop bits in the data packets that are communicated between the devices, this will indicate when to start and stop receiving or transmitting data. the data transmitted through the UART devices originated from the data bus on the circuit the UART is implemented within. When sampling, the two UARTS must have the same sampling baud rate, this will ensure the data isn't sent too quickly which will output erroneous data that will not be consistent with the receiver or transmitter. UART follows the IEEE communication standards. This will be used in this project as the Raspberry Pi, Arduino Mega, ATmega2560 and the ATmega16U2 have UART on board. This may be used to communicate these development boards and microcontrollers to each other or certain electrical components that are applicable.

3.2 Strategic Components and Part Selections

This section of the project documentation identifies and establishes the parts selected to build the autonomous grass cutter. Selected parts will be decided by the Mechanical Engineering Team. Those parts have a summary of the elements that need to be taken account for in the selection process. Each sub section will identify and establish each component chosen and the research behind why a specific component was chosen. There will be a comparison with other components that were considered. It is possible that what could be a better component was not selected due to any of the applicable standards, limited budget, limited resources or design constraints. The tables below show the parts selection overview and descriptions that may be used for this project. The tables below are split up into categories that will follow the part selection descriptions in the following sub-chapters. Table 19 below shows the microcontrollers and development boards part selection overview.

Table 19: Microcontrollers and Development Boards Parts Selection Overview

Item	Description
Development Board	1xRaspberry Pi 3 Model B
Microcontroller	1xATmega2560
Development Board	1xArduino Mega
Microcontroller	1xATmega16U2

Table 20 below shows the boundary system part selection overview. This includes parts for the perimeter receiver and generator circuits.

Table 20: Boundary System Parts Selection Overview

Item	Description
Perimeter Wire	1xAutomower Boundary Wire
20AWG 1M Cable	1x20AWG 1M cable for testing the perimeter wire system
Screw Terminals	3xED10561-ND, 125V, 6A, 1x02 2.54mm Screw Terminals
NE555P Timer	1xNE555P Timer to generate square wave signal
EJ503A Power Jack	1xEJ503A Power Jack used as a power connector to generator circuit from the 12-Volt battery
LM324N	1xLM324N Operational Amplifier to amplify the signal detected from boundary system
Resistors	Various resistors used that include: 4x1M Ω (1206), 4x10k Ω (1206), 1x3.3k Ω (1206), 1x12k Ω (1206), 1x47 Ω (2W Axial-0.6)
Variable Resistor	1xS64W Variable resistor 4.7k Ω , 3296W to adjust frequencies of square wave signal
Capacitors	Various capacitors used that include: 2x22nF(1206), 1x100nF(50V 1206), 1x100nF(1206), 1x1 μ F(1206), 1x1.2nF(1206)
Inductors	2xRLB0914 Inductors 1mH, 420mA use as receiver sensors
Inductor Wires	Wires to connect the inductors to the circuit

Table 21 below shows the sensors and location part selection overview. This includes all the sensors, camera and GPS module.

Table 21: Sensors and Location Parts Selection Overview

Item	Description
Night Vision Camera	1xRaspberry Pi 3 Model B Night Vision Camera
Ultrasonic Sensor	2xHC-SR04 Ultrasonic Sensor
Battery Charge Sensor	1xLiPo Fuel Gauge Battery Charge Monitor
GPS Module	1xHolybro Micro M8N GPS Module
Pin Header	1x08 Pin Header for Ultrasonic Sensors
Pin Header	1x06 Pin Header for GPS Module

Table 22 below shows the navigation and drive part selection overview. This includes the motor control parts, motors and wireless communication parts.

Table 22: Navigation and Drive Parts Selection Overview

Item	Description
USB Wi-Fi Module	1xUSB Wi-Fi (802.11b/g/n) Module with Antenna
Motor Driver Chip	3xL293DNE Motor Driver Chip
Wheel Motors	2xDC 12V/180RPM Geared Motor
String-Based Blade Motors	3xMachifit 895 DC Gear Motor

Table 23 below shows the power system part selection overview. This includes the voltage regulators, batteries and circuit components.

Table 23: Power System Part Selection Overview

Item	Description
Step-Down Voltage Regulator	1xLM2673S-ADJ 3-A Step-Down Voltage Regulator with Adjustable Current Limit
LDO Voltage Regulator	1xLP2985-33 Low Drop Out Voltage Regulator
LMV358 Operational Amplifier	1xLMV358 Low-Voltage Rail-to-Rail Output Operational Amplifier
Chip Resistor Array	Various chip resistor arrays used that include: 1x1k Ω (CAY16), 2x10k Ω (CAT16), 1x22 Ω (CAY16)
Resistors	Various resistors used that include: 1x8.25k Ω (1206), 1x1k Ω (1206), 1x3.16k Ω (1206)
Diode	1xMBRD360T4G T0-252-2 Schottky Diode
Capacitors	Various capacitors used that include: 2x100nF(1206), 1x10nF(1206), 2x100 μ F(595D), 1x330 μ F(Case-D 7343), 1x1 μ F(1206), 1x100nF (1206)
Inductors	1xXAL1010-152MEB Fixed Inductor 1.5 μ H
MOSFET	1xFDN340P Single P-Channel, Logic Level, Power Trench MOSFET
Screw Terminals	7xED10561-ND, 125V, 6A, 1x02 2.54mm Screw Terminals
Battery Wires	6xBattery Wires to the battery terminals
Motors Battery	1xDMD 100Ah/12V Li-Ion Battery
Electrical Components Battery	1xYinkai Power 20Ah/12V Li-Ion Battery
Perimeter Wire Battery	1xGreatMax 10Ah/12V Li-Po Battery

Table 24 below shows the mechanical part selection overview selected by the Mechanical Engineering Team. This includes the frame material, wheels, bade type and trimmer head.

Table 24: Mechanical Part Selection Overview

Item	Description
Frame Material	Plastic
String-Based Trimmer Head	Pivotrim Pro String Trimmer
String-Based Blade	Nylon String-Based Blade
Shaft Adapters	0.5-inch shaft
Caster Wheels	Powertec Swivel Heavy Duty Caster
Front Wheels	MaxPower 335100 Lawn Mower Wheel

Table 25 below shows the PCB components part selection overview. This includes the circuit components such as resistors, capacitors, inductors, transistors, pin headers and screw terminals. All these components are integrated with the other parts mentioned above to create a custom-made PCB that will result in a fully functional grass cutter system.

Table 25: PCB Components Part Selection Overview

Item	Description
PCB	Ordered from JLCPCB and designed on EasyEDA.com
Resistors	Various resistors used that include: 2x1M Ω (1206),
Capacitors	Various capacitors used that include: 7x100nF(1206), 3x22pF(1206), 1x1 μ F(1206)
Solder Jump	2xSJ
Wires Pack	Variety of Jumper Wires
Chip Resistor Array	1x1k Ω (CAY16)
Crystal	1xCSTCE16M0V53-R0 16MHz Crystal
Crystal	1xQS 16MHz Crystal
Inductor	1xBLM21(0805)
Reset Fuse	1xMF-MSMF050-2 500mA
Varistor	2xCG0603MLC-05E Varistor (0603)
Diodes	2xCD1206-S01575 Diode 100V, 150MA (1206)
Tactile Switch	1xTS42031-160R-TR-7260 Tactile Switch
Pin Header	2x(3x2M 2x03 Pin Header)
Pin Header	1x(2x2M -NM 2x02 Pin Header)
Pin Header	5x(8x1F-H8.5 1x08 Pin Header)
Pin Header	1x(10x1F-H8.5 1x10 Pin Header)
Pin Header	1x(18x2F-H8.5 2x18 Pin Header)
USB port	1xPN61729 USB-B Port
Breadboard	1xBreadboard for testing electrical components and circuits
Bolts	Variety
Nuts	Variety

3.2.1 Development Boards Selection

Exploring the needs of the project will help determine an appropriate development board. In this case, a development board is needed that can support the high processing power demands of computer vision and image processing and wireless communications. Another development board is needed to test the microcontroller that will be implemented onto the custom-made PCB for the overall grass cutter system. The development board with the selected microcontroller that is applicable, can be tested through the development board

and then later implemented onto the final PCB design. The development boards can support the testing of the electrical components such as the motor driver chips, ultrasonic sensors, GPS module, voltage regulators, and camera. The combination of these systems will be programmed using familiar languages such as C, C++ and Python. The navigational system will use a camera. The development boards selection are shown below in Table 26 with reference to datasheets [A11], and [A2].

Table 26: Development Boards Selection

	Raspberry Pi 3 Model B [A11]	Arduino Mega 2560 [A2]
Manufacturer	Raspberry Pi	Arduino
Price	\$35.00	\$38.50
Size	85x56mm	101.52x53.3mm
Key Elements	<ul style="list-style-type: none"> -BCM43428 Wireless LAN and BLE on board -40-pin extended GPO -CSI camera port -DSI display port -1GB of Ram -Quad Core 1.2GHz Broadcam BCM2837 64-bit CPU 	<ul style="list-style-type: none"> -54 Digital I/O pins -15 PWM outputs from Digital I/O Pins -16 Analog Input Pins -256KB of Flash Memory -8KB of SRAM -4KB of EEPROM -16MHz Clock speed -ATmega2560 Microcontroller
Part Selected	This part highlighted was selected for the high compatibilities with running computer vision and image processing. This board will be used for all the camera and path planning algorithms.	This part highlighted was selected for the high compatibilities with controlling the overall system of the robot. This board will be used for testing the ATmega2560 microcontroller chip.

3.2.1.1 Raspberry Pi Model 3 B [35]

Raspberry Pi 3 Model B runs at 1.4GHz with 1GB of memory. It is manufactured by Raspberry Pi and costs \$35.00. Capable of supporting a camera input, as well as enough I/O pins to support the many different sensors desired in the design. This microcontroller also operates at 5V and has 4 USB 2.0 ports. It supports Wi-Fi, and BLE protocols. This model includes the Quad Core Broadcom BCM2837 64-bit ARMv8 processor. It also includes an integrated GP-Video Core IV, which runs at 400MHz. This selection should be suitable enough for the needs of this project, as the robot will have a demanding computer vision architecture to make important navigational decisions. It can be programmed in many different languages including C, and C++. It also supports its very own operating system, the Raspbian OS. This is the development board that will be used in the project as shown below in Figure 16, used with permission from Adafruit.com. .



Figure 16: Raspberry Pi Model 3 B used with permission from Adafruit.com [36]

3.2.1.2 Arduino Mega 2560 [37] [38]

The Arduino Mega 2560 is a development board with the ATmega2560 microcontroller. It is manufactured by Arduino and costs \$38.50. The purpose of selecting this board is to test the functionality and specifications of the ATmega2560 microcontroller before the implementation of this microcontroller onto the final PCB design. This is done because this chip is hard to test on a breadboard due to it being a surface mount device. The Arduino Mega 2560 that will be used in this project for testing is shown below in Figure 17, picture taken by Brandei Dieter.



Figure 17: Arduino Mega picture taken by Brandei Dieter

3.2.2 Microcontrollers Selection

The microcontrollers need to be able to support the overall motor control, GPS modules, obstacle avoidance, obstacle detection, USB communications, and overall system control of the grass cutter robot. The microcontrollers on a development board can be integrated into a custom-made PCB design which is ideal for this project per ECE requirements. The combination of these systems will be programmed using familiar languages such as C and

C++. It will communicate with the obstacle avoidance system that will use an ultrasonic sensor to measure the distance away from objects using an RF signal. The microcontroller needs to be able to utilize I2C, UART, and SPI communication protocols with RF capabilities. A high performance, but low power microcontroller is an important feature because much of the power will be allocated to the navigation as well as driving the motors. DC motors will be used in the implementation of the drive system. The microcontrollers selection are shown below in Table 27 with reference to datasheets [A14] and [A22].

Table 27: Microcontrollers Selection

	ATmega2560 [A14]	ATmega16U2 [A22]
Manufacturer	Microchip/Atmel	Microchip/Atmel
Price	\$12.00	\$2.53
Size	14x14x1mm	5x5x0.95mm
Key Elements	<ul style="list-style-type: none"> -54 Digital I/O pins -15 PWM outputs from Digital I/O Pins -16 Analog Input Pins -256KB of Flash Memory -8KB of SRAM -4KB of EEPROM -Operating Voltage of 5-Volts -Input Voltage of 6-20-Volts -16MHz clock speed -5 SPI pins for SPI communication -2 TWI pins for TWI communication -4 hardware UARTs and 8 Serial pins for TTL serial data communication 	<ul style="list-style-type: none"> -16KB of In-System Self-Programmable Flash -512B of EEPROM -512 of Internal SRAM -126 powerful instructions -32x8 general purpose working registers -22 Programmable I/O lines -Operating Voltage range of 2.7 to 5.5-Volts -1 UART and 2 SPI Digital Communication Peripherals
Part Selected	This part highlighted was selected for the high compatibilities with controlling the overall system of the robot. This chip will be used on the custom-made PCB design for the overall grass cutter system.	This part highlighted was selected for the high compatibilities with communicating with the USB port and the ATmega2560. This chip will be used on the custom-made PCB design for the overall grass cutter system.

3.2.2.1 ATmega2560 [39]

The ATmega2560 is a microcontroller with many capabilities. It is manufactured by Microchip/Atmel and costs \$12.00. This microcontroller is already implemented onto the Arduino Mega development board. In this project, the ATmega2560 will be integrated onto the PCB. It has 54 Digital I/O pins, 15 PWM pins, and 16 Analog Input Pins. It operates at 5 Volts. It has a clock speed of 16MHz with a flash memory of 256 KB, 8 KB of SRAM

and 4 KB of EEPROM. This microcontroller will be used for overall locomotion, motor control, obstacle detection, obstacle avoidance and sensors. It is not compatible of running OpenCV, but the Raspberry Pi will run the OpenCV and deliver the outputs to the Inputs of the Atmega2560. This is the microcontroller that will be used in Figure 18 below.



Figure 18: Atmega2560 Microcontroller picture taken by Brandei Dieter

3.2.2.2 ATmega16U2 [40] [41]

The ATmega16U2 is a microcontroller with many capabilities. It is manufactured by Microchip/Atmel and costs \$2.53. This microcontroller is already implemented onto the Arduino Mega development board. In this project, the ATmega16U2 will be integrated onto the PCB. It has 22 programmable I/O lines and 32x8 general purpose working registers. The purpose of this device is to communicate and process the USB port with the ATmega2560. This will allow the microcontrollers to have a port to be programmed and hooked to a computer to implement many software algorithms for the overall grass cutter system. It operates at a range of 2.7 to 5.5-Volts. It has a clock speed of 16MHz at 4.5-Volts with a flash memory of 16KB, EEPROM of 512B and Internal SRAM of 512B. This is the microcontroller that will be used in this project, shown below in Figure 19, used with reference from Microchip.com.

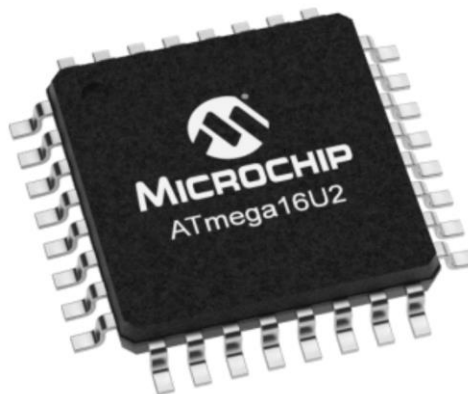

Figure 19: ATmega16U2 used with reference from Microchip.com [41]

3.2.3 Perimeter Boundary Wire Selection

The perimeter boundary wire is a crucial element in the functionality of the boundary system. A Buried Wire Fence (BWF) would be an ideal selection for this system. It is crucial to protect the perimeter wire from weathering to not interfere with the set frequency value flowing through it. Some shielding options are available to protect the BWF from being disturbed by local pest and deterioration. Once installed, the perimeter wire should not need any maintenance until being relocated in order to expand or change the autonomous grass-cutter's service area. The Perimeter boundary wire selection is shown below in Table 28.

Table 28: Perimeter Boundary Wire Selection

	Automower Boundary Wire [42]	Extreme Dog Fence Wire
Manufacturer	McCulloch	Extreme
Price	\$59.00	\$59.95
Length (m)	150	152.4
Key Elements	- Already water proofed with polyethylene plastic -Very durable -Used for mower and uses same type of inductive sensors	-Already water proofed with polyethylene plastic -Very durable -Multiple lengths of product are available
Part Selected	This part highlight was due to the lower costs, mower compatibility and specifications.	

3.2.3.1 Automower Boundary Wire [42]

The Automower Boundary Wire is manufactured by McCulloch and costs \$59.00. One roll comes with 150 meters of wire which is plenty for the boundaries this project will be testing. This is an ideal choice due to its durability and low costs compared to other boundary wires researched. This boundary wire is used for the McCulloch rob R600 and R1001. This is the boundary wire that will be used in this project as shown below in Figure 20.

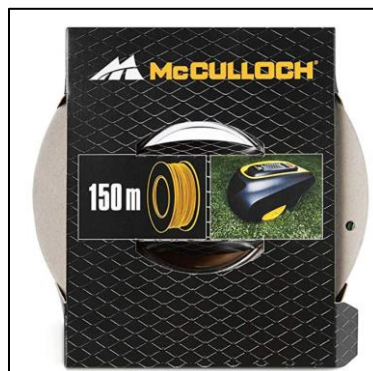

Figure 20: Perimeter Boundary Wire used with permission from Amazon.com [42]

3.2.3.2 Extreme Dog Fence Wire [43]

The Extreme Dog Fence Wire is manufactured by Extreme and costs \$59.95. The wire is used as an underground fence with a generated clock running through the wire that signal processes to the collar around a dog's neck. For this reason, the pet market for perimeter wires was used to find this product, the Extreme Dog Fence Wire. This wire comes with different gauge sizes. The chosen gauge size is 14 gauge which is the largest offered by this company. The larger diameter the wire, the stronger the signal and the more durable the wire is. This product is very durable and is water proofed already; because pet perimeters are outside, the product is designed with a coating around the copper inside of the wire. Instead of using a vinyl coat, this wire is coated with a polyethene plastic as a better weather proofed option. Both wire shielding approaches do not disturb the signal transmission as the product is designed to signal a sensor.

3.2.4 Timer for Perimeter Generator Circuit Selection

The timer for the boundary system is crucial for the system to function properly. The timer should be able to output a square wave signal throughout the Perimeter Wire. The circuit can be referred to as the 'generator circuit' that is implemented to generate a pulse at a specific frequency. The generator circuit, with its own power source, must also be kept safe from weather deterioration. Every time the grass-cutting robot is in operation, a timer like pulse must be generated through the perimeter wire. The perimeter wire power supply should have a battery life longer than the grass cutter to always maintain the boundaries. The timer for the boundary system selection is shown below in Table 29 with reference to datasheets [A10] and [A24].

Table 29: Timer for the Boundary System Selection

	NE555 Timer [A10]	CD4541B Timer [A24]
Manufacturer	Texas Instruments	Texas Instruments
Price	\$0.95	\$0.51
Size	8 Pins	14 Pins
Key Elements	<ul style="list-style-type: none"> -Frequency range of 32kHz to 44kHz -Operating temperature range from -55 degrees to 125 degrees -Vcc range from 5V-15V -Reset mode -TTL-Compatible Output can sink or source up to 200mA -Timing from microseconds to hours -Adjustable duty cycles -Accurate time delays and oscillations 	<ul style="list-style-type: none"> - Frequency range of 1kHz to 100kHz -Oscillator Option or Clocking Option -Operating temperature range from -55 degrees to 125 degrees -5, 10, and 15V parametric ratings -Auto reset mode and master reset mode (Auto mode not efficient)
Part Selected	This part highlight was selected due to its specifications and compatibility with the circuit design of the perimeter wire generator circuit.	

3.2.4.1 NE555P Timer [44]

The NE555P timer is manufactured by Texas Instruments and costs \$0.95. The Perimeter Wire Generator System will use 1x3.3k Ω , 1x 12k Ω , 1x 47 Ω resistors, 1x 4.7k Ω potentiometer, 2x 100nF, 1x 1.2nF, 1x 1 μ F Capacitors, 2.5mm center positive barrel connector, screw terminal (2P) and a NE555P Timer. The NE555P Timer will generate a square wave between the frequencies of 32kHz to 44kHz. This range of frequencies should not interfere with other electronic components frequency ranges. The NE555P Timer will require its own power source to control and deliver a pulse through the perimeter wire. The timer IC is equipped with a reset option to initiate a new timing cycle overriding all other inputs. The flip-flop is reset when the reset pin input is set to 0 (or low). This timer is manufactured by Texas Instruments as well as the CDC4541B Timer. While the NE555 timer does not come with an automatic reset option, by not including an automatic reset option power is saved within the circuit. The size of the circuit also remains smaller; only 8 pins are needed to implement the design of the timer onto a breadboard or a PCB board. This part is shown below in Figure 21.



Figure 21: NE555P Timer picture taken by Brandei Dieter

3.2.4.2 CD4541B Timer [45]

The CD4541B timer is a CMOS programmable timer manufactured by Texas Instruments and costs \$0.51. The timer can be programmed to produce a square wave output at frequency levels anywhere from 1kHz to 100kHz. Input voltages can range from 0.5V to 18V. The operating temperature range of the timer is anywhere from 55 degrees Celsius to 125 degrees Celsius. The device contains two pin outputs, one being the external clock (square-wave). Located at the other output pin, the device operates as an oscillator with frequency ranging from DC or 0Hz to 100kHz. Reset modes include an auto-reset and master option. The auto-reset option wastes a considerable amount of power and is not recommended for continued use if efficiency is desired. The master reset option resets the device by switching the amplitude back to a low position to begin recounting. Although this is a cheaper component, the NE555P timer is more ideal for this project.

3.2.5 Operational Amplifier for Perimeter Receiver Circuit

The operational amplifier is a crucial element for amplifying the signal received from the inductor coils from the signal captured from the perimeter wire. The purpose of this receiver circuit is to detect the square wave outputted by the Perimeter Wire Generator circuit and not go out of bounds. It will send the signals to the ATmega2560

microcontroller and generate an interrupt to the system to tell the grass cutter to do the proper operations (i.e. turn around, reverse). The perimeter's signal receiving operational amplifier selection is shown below in Table 30 with reference to datasheets [A9] and [A23].

Table 30: Perimeter Wire Receiver Operational Amplifier Selection

	LM324N Operational Amplifier [A9]	LF351 Operational Amplifier [A23]
Manufacturer	Texas Instruments	Fairchild Semiconductor
Price	\$0.52	\$1.18 per amplifier
Size	-14 PINS, 19.56 mm × 6.67 mm	-8 PINS, Tiny
Key Elements	<ul style="list-style-type: none"> -Large DC gain of 100DB -Power Dissipation is from 800mW-1130mW (depending on used operations) - Operational Temp is from 0 to 70 degrees Celsius -Wide bandwidth 1MHz -Input Voltage range from 0-30V -Four internal Op Amps in one package -Power Drain suitable for battery operation 	<ul style="list-style-type: none"> -Vcc -18 to +18V -Power Dissipation is 500mW -Operational Temp is from 0 to 70 degrees Celsius -Wide bandwidth 4MHz -JFET internal inputs -Input Impedance value of $10^{12}\Omega$ - Input Voltage $\pm 15V$
Part Selected	This part highlight was selected due to its specifications required for this project. The LM324N amp is suitable for battery operating conditions. It's bandwidth is smaller in comparison; nonetheless, the perimeter wire circuit will not require higher frequency values.	

3.2.5.1 LM324N Operational Amplifier [46]

This Perimeter Wire Receiver System will use 3x 10k Ω , 3x 1M Ω resistors, 2x 2nF Capacitors, an LM324N Quad Operational Amplifier, 2 2.54mm 3-pin M/M headers, and 2 1mH inductors. The LM324N operational amplifier is used to amplify the signal received through the inductors and send that amplified signal to the microcontroller. This part is shown below in Figure 22.



Figure 22: LM324N Operational Amplifier picture taken by Brandei Dieter

3.2.5.1 LF351 Operational Amplifier [47]

Another option of an operational amplifier to use for the perimeter boundary system is the LF351N Operational Amplifier having a wide bandwidth in case the signal in the perimeter wire gets distorted. If the copper wire around the perimeter has ever been broken and re-spliced, the signals frequency may have a wider marginal error. Therefore, it is thought that this operational amplifier may be of use for the design. There is a supply voltage of ± 18 -Volts with a differential input voltage of 30-Volts. Although this operational amplifier has good specifications, the LM324N operational amplifier is more ideal for this project.

3.2.6 Camera Selection

The camera for this system will be used to help determine any obstructions in its path as well as give the robot instructions on which direction to move. Some of the factors are compatibility with the microcontroller that is used to create the robot. In this case, we want a camera that will work with the microcontroller, but also be efficient enough to give us good quality imaging for robustness when implementing computer vision software onto the system. There are many ways to connect a camera, some require specific ports, while others merely use USB port to transmit the video. The camera selection is shown below in Table 31 with reference to datasheets [A17] and [A25].

Table 31: Camera Selection

	Raspberry Pi 3 Model B Night Vision Camera [A17]	Raspberry Pi Camera Module V2 [A25]
Manufacturer	Unistorm	Raspberry Pi
Price	\$25.99	\$24.90
Size	4.5x2x1.2 in	4.7x0.9x3 in
Key Elements	<ul style="list-style-type: none"> -Night Vision capability -Low costs -5 MP Fisheye Camera Lenses -1080P sensor resolution - 72 degrees field of view -infrared or flash LED compatibility -Compatible with Raspberry Pi -LEDs automatically turn on when the environment around the camera gets dark 	<ul style="list-style-type: none"> -8 MP native resolution high quality Sony IMX219 Image sensor -Capable of 3280x2464 pixel static images -Compatible with Raspberry Pi -Maximum of 1080P30 in Raspberry Pi Board
Part Selected	This part highlighted was selected due to the night vision and raspberry pi compatibilities. It will allow the robot to run during any time throughout the day.	

3.2.6.1 Raspberry Pi 3 Model B Camera Fisheye [48]

Raspberry Pi 3 Model B Camera Fisheye 5 Mega Pixel. This camera comes well equipped with night vision as well as small flashlights on either side. The LEDs automatically detect

when it is in a light or dark environment and turn on to aide in the camera's vision despite what time of day it is. This device is manufactured by Unistorm and costs \$25.99. This camera is a very good selection for the project because it will allow the robot to cut grass at night, which satisfies a design principle stated in the requirement specifications. This camera is connected through CSI (Camera Serial Interface), so the microcontroller must be compatible and have the correct ports to meet the need of this technology. This camera also has a best resolution of 1080p, focal length of 2.1, diagonal angle of 130 degrees and provides 3.3V power output. This camera has very high quality and a variety of capabilities. It is cost efficient and meets all the requirements of the project. This is the camera that will be used in this project as shown below in Figure 23.



Figure 23: Raspberry Pi 3 Model B Night Vision Camera picture taken by Brandei Dieter

3.2.6.2 Raspberry Pi Camera Module V2 [49]

Raspberry Pi Camera Module V2 is an 8 Megapixel camera that can handle multiple resolutions that can be used in different circumstances. This device is manufactured by Raspberry Pi and costs \$24.90. It includes a high quality 8MP Sony IMX210 image sensor with a fixed focus lens. It is capable of supporting 3280x2464 pixel static images along with 1080p30, 720p60 and 640x480p60/90 videos. Perhaps this selection for the project can prove to be modest, however it lacks in features. Some features this camera could include are night vision, as well as a light attachment for illumination. This camera is also compatible with Raspberry Pi, which would be ideal for this project's conditions. Although the compatibilities and specifications of this camera would be suitable for this project, this camera will not be chosen due to its poor quality of vision at night.

3.2.7 Obstacle Avoidance Sensors Selection

There are many options for implementing an obstacle avoidance sensor. For this project some considerations were an ultrasonic sensor to calculate the distance between the system and any objects or obstacles in its path to avoid damaging the surrounding infrastructure, objects, obstacles, humans and the robot itself. Ultrasonic sensors can measure the distance by emitting a sound wave via a transducer. As a result, the signal will reflect off anything in the signal's path and will be listened to by the sensor. Since the frequency of the signal is known and can be measured, then the wavelength is known. The distance can be calculated using the time it took to transmit back to the sensor and the wavelength. Another option to use would be an infrared sensor that can be used for motion detection as well as

serving as a proximity sensor. The Obstacle avoidance sensors selection is shown below in Table 32 with reference to datasheets [A13], [A26] and [A27].

Table 32: Obstacle Avoidance Sensors Selection

	HC-SR04 Ultrasonic Ranging Module [A13]	PING Ultrasonic Module [A26]	Arduino IR Collision Avoidance [A27]
Manufacturer	Arduino	Parallax	Gikfun
Price	\$2.50	\$18.00	\$7.98
Size	42x20x15mm	22x46x16mm	3.7x2.8x1.2in
Key Elements	<ul style="list-style-type: none"> -Min. range of 2cm -Max. range of 4m -Sends out eight 40kHz frequency signals -Operates using sonar 	<ul style="list-style-type: none"> -Minimum range of 2cm -3 meters of accuracy -Operates at a 40kHz short ultrasonic bursts -Operates using sonar 	<ul style="list-style-type: none"> -Minimum range of 2cm -Maximum range of 30cm -Operates using Infrared
Part Selected	This part highlighted was selected due to the lower costs, high maximum range and accuracy		

3.2.7.1 HC-SR04 Ultrasonic Ranging Module [50]

The HC-SR04 Ultrasonic Ranging Module includes ultrasonic transmitters, receivers and control circuit. It is manufactured by Arduino and costs \$2.50. The IO trigger will be used for at least 10us high level signals. The module will automatically send eight 40kHz frequency signals and detect if a pulse signal is sent back. When an object is detected, it will send the pulse signal back as a high-level signal. The time of high output IO duration is the time from when the signal was sent to when the signal was returned. This model has four pins that includes a 5 Volt power supply, trigger pulse input, echo pulse output and ground. It has a working voltage of 5 Volts DC, working current of 15mA, working frequency of 40Hz, a maximum range of 4 meters and a minimum range of 2 centimeters. The Trigger Input signal is a 10 micro second TTL pulse and the Echo Output signal is proportional to the input signal. This is the ultrasonic sensor, in Figure 24, that will be used in this project as shown below.



Figure 24: HC-SR04 Ultrasonic Sensor picture taken by Brandei Dieter

3.2.7.2 PING by Parallax [51]

The PING sensor manufactured by Parallax provides a pulse in, and a pulse out. It is manufactured by Parallax and costs \$18.00. It operates at a working current of 20mA. The range is a minimum of 2 centimeters to a maximum of 3 meters of accuracy. The supply voltage for this device is 5V. It will operate at a frequency of 40KHz short ultrasonic bursts to measure the distance between itself and any obstructions in its path. Some issues with this sensor are reflective surfaces and poor positioning. This part was not selected due to the higher costs.

3.2.7.3 Arduino Infrared Collision Avoidance Module [52]

The Arduino Infrared Collision Avoidance Module operates using Infrared. It has a range of 2 to 30 centimeters. It is manufactured by Gikfun at a cost of \$7.98. It consists of an infrared transmitter and an infrared detector. It uses a LM393 comparator and has an operating voltage range of 3.3 to 5 Volts. It has two digital output interfaces. The light sensors are adaptable to the environment but does not do well in dark areas. This is not ideal for this project due to customer's desires of the grass cutter being able to run at any time throughout the day.

3.2.8 Battery Charge Sensors Selection

The battery charge sensors are necessary to monitor the battery charge percent left for the motor's battery. The motors battery only needs to be monitored due to the high-power usage. The electrical component's battery and the perimeter wire generator battery will last long after the motors battery has run out of charge. When the charge gets below a certain percentage, around 30%, the system will send off a ping of the location. This is done so the user can go have the batteries charged. The battery charge sensor selection is shown below in Table 33 with reference to datasheet [A16].

Table 33: Battery Charge Sensors Selection

	MAX17043 Fuel Gauge [A16]	BQ27441-G1 Fuel Gauge [A28]
Manufacturer	Robotshop.com	Texas Instruments
Price	\$9.95	\$19.95
Size	8-Pin, 2mm x 3mm	12-pin, 2.50 mm × 4.00 mm
Key Elements	<ul style="list-style-type: none"> -Compatible with Lithium-Ion and Lithium-Polymer Batteries -Compatible with single cell or two cell batteries -High efficiency -Max. voltage rating is 12V -Low battery alert signal -Temp range -20 to +70 degrees Celsius 	<ul style="list-style-type: none"> -Compatible with single cell lithium-Ion batteries -Maximum voltage rating is roughly 5V -Reports battery capacity remaining and state of charge -Temp range -40 to +85 degrees Celsius
Part Selected	This part highlighted was selected due to the allowed input voltage being 12V, Price and size comparisons as well.	

3.2.8.1 MAX17043 Fuel Gauge Power Management Board [53]

The MAX17043 Fuel gauge power management evaluation board are ultra-compact, low-cost, host-side fuel gauge systems for lithium ion batteries. It is manufactured by Spark Fun Electronics and costs \$9.95 from Robotshop.com. It requires a supply voltage of 2.5-4.5 Volts. It has a SCL clock frequency of 0-400kHz. The precision voltage measurement is $\pm 12.5\text{mV}$ accuracy to 5-Volts. It has no offset accumulation on measurements, no full-to-empty battery relearning necessary and no sense resistor required. It has 1 cell host-side/battery-side fuel gauging. They cost on an average of \$9.95 from Robotshop.com. This device is ideal for this project due to the low power consumption, high capabilities, specifications and capability of monitoring Lithium Ion batteries that will be used in this project. This device is shown below in Figure 25.

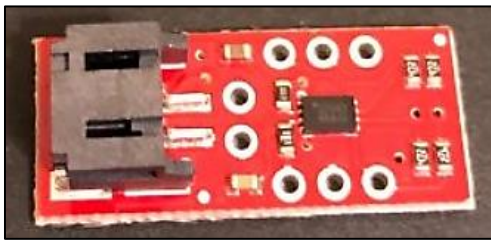

Figure 25: MAX17043 Fuel Gauge Power Management Board picture taken by Brandei Dieter

3.2.8.2 BQ27441-G1 System-Side Impedance Track Fuel Gauge [54]

Texas Instruments manufactures the BQ27441-G1 fuel gauge using patented Impedance Track technology. The board reports remaining battery capacity and the state of charge. This information can be found on the products datasheet located on the Texas Instruments website. The small 12-pin, 2.50 mm \times 4.00 mm fuel gauge microcontroller board is used for single-cell lithium Ion batteries. The maximum input voltage for this battery fuel gauge is roughly 5V and the board also regulates an output voltage of 1.8V. The fuel gauge board is to be directly connected to the battery source and can be connected to battery packs as well as embedded batteries. The price to purchase this board from Digikey is \$19.95. Although this board has great specifications for this project, it has a higher cost than the previous battery charge sensor module.

3.2.9 Digital Compass and GPS Module Selection

The digital compass and GPS Module are necessary for the position and location of the Grass Cutter. It will be needed to ping the location of the grass cutter after the main system battery has died. The considerations of selecting this module would be the accuracy, efficiency and range of the GPS and Compass. A possible technology combination that could be used with the digital compass and GPS module is mapping the field and obstacles and tracking the location of the robot from the start point to get a more precise location. This application may work in conjunction with the camera's path planning, mapping and self-localization to get more accurate positioning and location. The digital compass and GPS module selection are shown below in Table 34 with reference to datasheet [A12].

Table 34: Digital Compass and GPS Module Selection

	Holybro Micro M8N GPS Module [A12]	RadioLink SE100 GPS Module
Manufacturer	Holybro	RadioLink
Price	\$36.99	\$30.00
Size	38x38x11mm	48.5x48.5x15.3mm
Key Elements	<ul style="list-style-type: none"> -167 dBm navigation sensitivity -Update rate up to 10Hz -Cold starts at 26s -LNA MAX2659ELT+ -Rechargeable 3 Volt backup battery for warm starts -Low noise 3.3 Volt regulator -HMC5983L Built-in Compass -Ceramic Path Antenna 	<ul style="list-style-type: none"> -167 dBm sensitivity -Cold starts at 26s -Hot starts at 1s -Max Update rate up to 18Hz -2.5 dbI High gain and selectivity ceramic antenna -MMIC BGA715L7 IC Power Amplifier -SAWF double filter -Radiolink M8N GPS with U-Blox UBX-M8030(M8)
Part Selected	This part highlighted was selected due to the backup lithium ion battery for the GPS module that is required in this project and specifications of this device.	

3.2.9.1 Holybro Micro M8N GPS Module

The Holybro Micro M8N GPS Module includes an industry leading -167 dBm navigation sensitivity, navigation update rate up to 10Hz, rechargeable 3 Volt lithium backup battery, low noise 3.3V regulator, power and fix indicator LEDs, 15cm PIXFALCON μ APM compatible 6-pin cable, 25x25x4mm ceramic patch antenna and an LNA MAX2659ELT+. This new design incorporates the HMC5983L digital compass that uses the Ublox latest 8series module providing a convenient method of mounting the compass away from source of interferences from surrounding devices. This device costs an average of \$36.99. This is the device that will be used in this project for location and position, shown below in Figure 26.



Figure 26: Holybro Micro M8N GPS Module picture taken by Brandei Dieter

3.2.9.2 RadioLink SE100 GPS Module

The RadioLink SE100 GPS Module has GPS decode chips of the RadioLink M8N GPS with U-Bloc UBX-M8030 (M8), 72-channels and a MMIC BGA715L7 Power amplifier. This design includes a geomagnetic HMC5983. It has a 50-centimeter position accuracy, positions 20 satellites in 6 seconds at open ground and a valley station-keeping ability. Although the specifications of this device are quite good, the need of a backup battery to ping of the location is needed for this project.

3.2.10 Wireless Chip Selection

The wireless chip selection is vital to this project to communicate information to and from the laptop application. The wireless chip should provide a longer range of the Wi-Fi module on the Raspberry Pi 3 Model B Development board. The on-board Wi-Fi module on the Raspberry Pi 3 Model B has an unreliable short-range wireless communication. This wireless chip should boost the signal to a range of at least 50 feet from the grass cutter to the laptop application. It should be able to transmit and receive all the data needed from the grass cutter robot to the laptop application. The Wireless Chip Selection is shown below in Table 35 with reference to datasheet [A15].

Table 35: Wireless Chip Selection

	USB Wi-Fi Module with Antenna for Raspberry Pi [A17]	GP-Xtreme Mini Compact USB 2.0 N [55]
Manufacturer	Adafruit.com	GP-Thunder
Price	\$19.95	\$9.99
Size	Antenna Length of 150mm Sticks out 48mm beyond USB port	19x11x6mm
Key Elements	<ul style="list-style-type: none"> -High speed USB 2.0/1.1 Interface -Data rate up to 150Mbps downlink and uplink -Frequency band of 2.5GHz ISM -Data security 64/128-bit WEP Encryption -Supports wireless roaming, data rate auto fallback under noisy environments and longer-range distance -Compatible with Raspberry Pi 	<ul style="list-style-type: none"> -Mini USB Wi-Fi Adapter -802.11b/g/n WLAN USB adapter -Supports up to 150Mbps high-speed wireless network connections -Supports 802.11i (WPA, WPA2) -Supports 802.11e Qos Enhancement (WMM) -Supports 802.11h TPC, Spectrum Measurement -Ultra compact size -Compatible with Raspberry Pi
Part Selected	This part highlighted was selected due to the high ranges, antenna, data security encryptions and specifications.	

3.2.10.1 USB Wi-Fi (802.11b/g/n) Module with Antenna for Raspberry Pi [56]

The USB Wi-Fi Module comes with an antenna to boost the signal range. It is compatible with the Raspberry Pi Development Board that will be used in this project. The wireless chip is about the size of a quarter, not including the antenna. This chip has a range coverage up to three times farther than 802.11g. It supports 14 universal domain radio channels. It has full mobility and seamless roaming from cell to cell. It has an antenna length of 150mm, sticks out 48mm beyond the USB port, and weighs 6 grams. This module uses the RTL8192cu Chipset. It follows the wireless standards of IEEE 802.11n, IEEE 802.11g and IEEE 802.11b. It has a high-speed USB 2.0/1.1 interface, frequency band of 2.4GHz ISM, RF frequency of 2412-2462 MHz in North America, an RF output power of 13-17 dBm and 64/128-bit WEP security encryption. The advantages are the low costs, security, high range and quality. This module costs \$19.95 from adafruit.com. This is the wireless chip that will be used in this project. This is the module that will be used in this project as shown below in Figure 27.



Figure 27: USB Wi-Fi Module with Antenna used with permission from Adafruit.com

3.2.10.2 GP-Xtreme Mini Compact USB 2.0 N [55]

The GP-Xtreme Mini Compact USB 2.0N is a wireless chip with an antenna built-in. This chip has an antenna that can transmit greater than 305mA and receive less than 190mA. It is about the size of a penny. This module uses the Ralink RT5370 RF chipset. It supports up to 150Mbps high-speed wireless network connections. This wireless chip has an operating range up to 300 meters depending on the environment it is in. It operates at a frequency range of 2.412 to 2.484 GHz. It follows the wireless standards of IEEE 802.11b, IEEE 802.11g and IEEE 802.11n. It supports 64/128bit WEP encryption security types. Although this would be ideal, the above choice has a greater range which would be more ideal in the solar farms.

3.2.11 Motor Driver Chip Selection

The Motor Driver Chip Selection is a crucial element for the control of the motors to power the string-based blades and rear wheels. The need of H-bridges is needed to control the motors bi-directionally. They should be capable of controlling at least 2 DC motors bi-directionally and independently. The elements that should be considered are the number DC motors it can control, the compatibilities of controlling the motors bi-directionally, what loads it can handle, the current limits and voltage specifications needed. The Motor Driver Chip Selection is shown below in Table 36 with reference to datasheet [A4].

Table 36: Motor Driver Chip Selection

	L293DNE Motor Driver [A4]	DRV8842 Motor Driver [57]
Manufacturer	Texas Instruments	Texas Instruments
Price	\$3.34	\$3.59
Size	19.8x6.35mm	367x367x38mm
Key Elements	<ul style="list-style-type: none"> -Quadruple Half-H Drivers -Each pair of drivers form a full-H (or bridge) -Reversible drive suitable for motor applications -Drive two DC motors bi-directionally -Control motors speeds and motors voltages from 4.5 to 36 V -Function table to control motors 	<ul style="list-style-type: none"> -Single H-bridge Current-Controlled Motor Driver -Operating Voltage of 8.2 to 45 Volts -Five-bit Winding Current Control allows up to 32 current levels -Overcurrent protection -Thermal Shutdown -Separate inputs available to independently control each half of the H-bridge
Part Selected	This motor driver highlighted was selected due to the specifications and compatibilities needed to drive the DC motors for this project.	

3.2.11.1 L293DNE Motor Driver Chip [58]

The L293DNE Motor Driver Chip contains quadruple Half-H drivers or two full H-Bridges. It can drive two DC motors bi-directionally with a current limit of 600mA. Some applications that it supports are DC motor drivers, stepper motor drivers and latching relay drivers. It can control the motors speed and motor voltages from 4.5 to 36 Volts. There is internal ESD protection and high-noise-immunity inputs. Each output of the motor driver is a complete totem-pole drive circuit that includes a Darlington transistor sink and a pseudo-Darlington source. There are six inputs and three outputs in the function table of each driver. The inputs include H(High level), L(Low level) and X(Irrelevant) states. The outputs include H(High level), L(Low level) and Z(High impedance-off) states. Using this function table, the motor driver will send the outputs to the DC motors and control the speed, operation and direction. In the case of thermal shutdown mode, the output is in the Z state regardless of what the input state is. In Figure 28 below is the L293DNE Motor Driver Chip that will be used.



Figure 28: L293DNE Motor Driver picture taken by Brandei Dieter

3.2.11.2 DRV8842 DC Motor Driver IC [57]

The DRV8842 DC Motor Driver IC features a single H-Bridge current-controller motor driver. It has an operating supply voltage range of 8.2 to 45 Volts. It has a five-bit winding current control that allows up to 32 different current levels. Although the specifications of this driver are quite good, the need of this driver to control multiple DC motors at once is not ideal.

3.2.12 Wheel DC Motors Selection

The wheel DC Motors Selection is a crucial element for the motion and navigation of the grass cutter. They should be capable of handling a large load, high torque specifications and low power consumption. The wheel DC motors selection is shown below in Table 37.

Table 37: Wheel DC Motors Selection

	DC 12V/180RPM Geared Motor [59]	Cytron 12V Spur Gear Motor [60]
Manufacturer	Banggood.com	Cytron Technologies
Price	\$12.68	\$14.61
Size	Not Available	Not Available
Key Elements	-High rated torque of 27.0 Kg-cm -Low rated speed of 120 RPMs -Low costs	-High rated torque of 194 oz-in -Low rated speed of 12.5 RPMs -Low costs
Part Selected	This part highlighted was selected due to the high torque, low speed, low power and specifications.	

3.2.12.1 DC 12V 180RPM Geared Motor [59]

The DC 12V 180RPM Geared Motor is manufactured by banggood.com. It has an input voltage of 12 Volts and retarder reduction ratio of 1:90. It has a rated torque of 27.0 Kg-cm and rated speed of 120 RPMs. This motor choice is ideal for the low costs, high torque, low speed, low power consumption and meets the specifications needed for the wheel motors. This motor costs \$12.68 from Banggood.com. This is the motor that will be used in this project shown below in Figure 29.



Figure 29: DC 12V 180 RPM Geared Motor used with permission from Banggood.com

3.2.12.2 Cytron 12V Spur Gear Motor [60]

The Cytron 12-Volt Spur Gear Motors are manufactured by Cytron Technologies. It has a gear ratio of 270:1, nominal voltage rating of 12-Volts, rated torque of 194 oz-in and a rated RPM of 12.5. The D-Shaped shaft type is a perfect type for the wheel shaft adapters included with the Dagu Wild Thumper Wheels. Each motor is priced at \$14.61 each. Although these specifications are good, it does not have enough torque needed for this project's applications.

3.2.13 String-Based Blades DC Motors Selection

The string-based blade DC Motors Selection is a crucial element for the rotating motion to cut the grass to an acceptable height across the terrain of a Solar Farm. They should be capable of handling a large load, high torque specifications and low power consumption. The DC motors need to rotate at around 3000 rpm for the nylon string-based blade to effectively and efficiently cut grass. The longer the string, the less force it will output to cut the grass. The DC Gear motors should maintain an average of 3000rpm to efficiently cut the grass. Three DC motors are going to be designed onto the grass-cutter robot in a triangular orientation attached to the frame of the robot. With three motors working independently, the edges and middle of the grass area relative to the robot will be cut. The power supply will support the DC motors with enough power to cut the grass efficiently. The String-Based Blades DC Motors selection is shown below in Table 38.

Table 38: String-Based Blades DC Motors Selection

	Machifit 895 DC Gear Motor [61]	RS-775 DC Gear Motor [62]
Manufacturer	Machifit	Robotshop.com
Price	\$15.99	\$10.00
Size	Not Available	46Dx66.5L mm
Key Elements	-Shaft Diameter of 5mm -Rated voltage of 12-24 V -Rated speed of 3000 rpm -Rated torque of 0.5099458 N-m	-Shaft Diameter of 5mm - Rated voltage of 12V -Rated speed of 6070 rpm -Rated torque of 10 oz-in
Part Selected	This part highlighted was selected due to the high torque, low speed and low power specifications.	

3.2.13.1 Machifit 895 DC Gear Motor [61]

The Machifit 895 DC Gear Motor is manufactured by Machifit. It has a rated voltage of 12-24Volts. For this application, 12 Volts will be used with a rated speed of 3000rpm, 0.5099458 Nm of torque, shaft diameter of 5mm and rated power of 200 Watts. To cut the grass with enough force, it will require a high torque motor that can handle a high load. Each motor is priced at \$15.99 each. This motor is a good consideration and has enough torque and force to cut the grass. This is the motor that will be used in Figure 30, shown below.



Figure 30: 895 DC Gear Motor used with permission from Banggood.com [61]

3.2.13.2 RS-775 DC Gear Motor [62]

The RS-775 DC Gear Motor is a high power and torque motor with vent holes. It is manufactured from Robotshop.com. It has an acceptable voltage of 6-30 Volts. It has a shaft diameter of 5mm and a shaft length of 16mm. At max power output, the power efficiency is 47.38%, torque of 361.51 mNm, speed of 4150 RPM, current of 13.822 A and output power of 157.21 Watts. These specifications are a good candidate for the specifications needed for the String-Based Blade motors, but the Machifit 895 DC Gear Motor is a better choice.

3.2.14 Voltage Regulators Selection

Voltage regulators are used to generate a fixed output voltage that remains constant regardless of the changes to its input voltage or load conditions. It is necessary to regulate the voltage from the batteries to the components. High efficiency is required to avoid power losses. The voltage regulator needed for this project will take a 12-Volt input and output 5-Volts. Voltage Regulators selection is shown below in Table 39 with reference to datasheets [A21] and [A7].

Table 39: Voltage Regulators Selection

	LM2596-ADJ Step-Down Voltage Regulator [A21]	LM2673S-ADJ Step-Down Voltage Regulator [A7]
Manufacturer	Texas Instruments	Texas Instruments
Price	\$4.73	\$4.86
Size	367x367x45mm	367x367x35mm
Key Elements	<ul style="list-style-type: none"> -Greater than 80% efficient -3.3 V, 5V, 12V and Adjustable output versions available -150kHz Fixed-Frequency Internal Oscillator -Low power standby mode ~80µA -Thermal Shutdown protection -Current-limit protection -On-card switching regulators -Maximum 3A output load current 	<ul style="list-style-type: none"> -Greater than 90% efficient -Fixed output versions of 3.3, 5 and 12-Volts and 1.2 to 37-Volts -260kHz fixed-frequency internal oscillator -Soft-start capability -Built-in thermal shutdown -Resistor programmable current limit of the power MOSFET switch -Maximum 3A output load current
Part Selected	This part highlighted was selected due to the higher power efficiency percentage, adjustable outputs, more capabilities and specifications.	

3.2.14.1 LM2596S-ADJ Step-Down Voltage Regulator [63]

This information was provided by the datasheet from Texas Instruments of the LM2596 Simple Switched Power Converter 150-kHz 3-A Step-Down Voltage Regulator. This device is manufactured by Texas Instruments and costs \$4.73. The power efficiency ranges from 80-86%. The LM2596S-ADJ Step-Down Voltage Regulator has an adjustable output version of 3.3, 5, and 12- Volts. The input is a 12 Volt unregulated DC input. It operates at a switching frequency of 150kHz. This package has a 3-A output load current and an input voltage range of up to 40 Volts. The advantages of this chip are the high efficiency, low costs, thermal shutdown and current-limit protections.

3.2.14.2 LM2673S-ADI Step-Down Voltage Regulator [64]

This information was provided by the datasheet from Texas Instruments of the LM2673 Simple Switcher 3-A Step-Down Voltage Regulator with Adjustable Current Limit. This device is manufactured by Texas Instruments and costs \$4.86. The power efficiency ranges from 85-90% with a fixed-frequency internal oscillator of 260KHz and maximum 3Ampere output load current. The LM2673S-ADJ step-down voltage regulator has an adjustable current limit that results in fixed outputs of 3.3, 5 and 12 volts and an adjustable output of 1.2 to 37 Volts. It has a wide input voltage range from 8 to 40 Volts with a fixed frequency internal oscillator of 260-kHz. It is up to 94% efficient with soft-start capabilities. This voltage regulator has a resistor programmable peak current limit over a range of 2 to 5 Amps with a 150-m Ω DMOS output switch. This allows the power MOSFET switch to protect the device and load circuitry under fault conditions. It has an operating junction temperature range of -40 to 125 degrees Celsius. This device is more ideal due to its higher power efficiency, better specifications and capabilities compared to the LM2596S Step-Down Voltage Regulator. This is the part that will be used in this project as shown below in Figure 31.

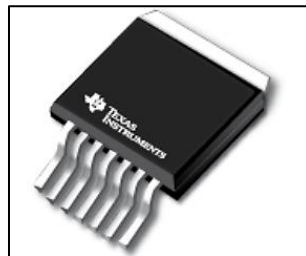

Figure 31: LM2673S-ADJ Step-Down Voltage Regulator used with permission from Texas Instruments

3.2.15 DC Motors Battery Selection

The DC Motors battery selection will be selected upon the considerations of high Watt-Hours, low-costs, high efficiency, and high cycle life. The proposed Watt-Hours of the battery should be between the range of 800-1500Watt-Hours. The selection details are shown below in the subchapters. The motors battery must have high Watt-Hours due to it supporting 5 DC motors. The DC Motors Battery selection is shown below in Table 40.

Table 40: DC Motors Battery Selection

	DMD 160Ah/12V Li-Po Battery [65]	DMD BMS 100Ah/12V Dry Cell Li-Ion Battery [66]	DMD 100Ah/12V Li-Ion Battery [67]
Manufacturer	DMD	DMD	DMD
Price	\$229.00	\$180.00	\$169.00
Size	325x245x60mm	346x262x62mm	260x260x60mm
Key Elements	-Highest Costs -Seven intelligent security features -Cycle life of 1000-1500 times	-Mid-Range Costs -Seven smart security features -Cycle life of 1800 or more times	-Lower Costs -Seven smart security features -Cycle life of 2000 times or more times
Part Selected	This battery highlighted was selected due to the low costs, smart security features, portability, higher cycle life and specifications of power.		

3.2.15.1 DMD 160Ah/12V Li-polymer Battery [65]

The DMD Li-polymer battery has a nominal voltage of 12 Volts and 160 Ah. It includes seven intelligent security features that include protection of over voltages, over currents, over charging, over discharging, short circuits, over power, and over temperatures. It includes a charging system with a charge current of 10A/Flash charge. The cycle life is 1000-1500 times. The advantages of this battery are the power indicator shown on the battery, charging terminal, power on/off switch, light weight and relatively low costs. This battery costs \$229.00 from Alibaba.com.

3.2.15.2 DMD BMS 100Ah/12V Dry Cell Lithium Ion Battery [66]

The DMD Lithium Ion battery has a nominal voltage of 12 Volts and 100 Ah. It includes smart security features of over-temperature protection, over-current protection, over-voltage protection, overload protection, reverse protection, short circuit protection and low voltage protection. This battery includes a charging system with a charge current of 10A/Flash charge. The cycle life is greater than 1800 times. The battery will automatically cut down when discharged to 9 Volts. The advantages of this battery are the power indicator shown on the battery, charging terminals, power on/off switch, light weight, portable and relatively low costs. This battery costs \$180.00 from Alibaba.com.

3.2.15.3 DMD 100AH/12V Lithium Ion Battery [67]

The DMD Lithium Ion Battery has a nominal voltage of 12 Volts and 100 Ah. It includes smart security features of over-voltage, over-charge, short circuit, over-charge, over-temperature, over-discharge and over-power. This battery includes a charging system with

a charge current of 5A. It has a large battery capacity and persistent output of 80%. The cycle life is 2000 times. The advantages of this battery are the large battery capacity, light weight, portable, charging terminals and relatively low costs. This battery costs \$169.00 from Alibaba.com. Due to the higher cycle life and lower costs than the other batteries compared, this is the battery that will be used in this project as shown below in Figure 32.



Figure 32: DMD 100Ah/12V Lithium Ion Battery used with permission from Alibaba.com [67]

3.2.16 Electrical Components Battery Selection

The electrical components battery will power all the electrical components even after the DC motors battery has died. The purpose of this battery is to ping the location to the laptop application after the DC motors battery has died to have the grass cutter found and charged. The Electrical Components Battery Selection is shown below in Table 41.

Table 41: Electrical Components Battery Selection

	Shenzhen 20Ah/12V Li-Po Battery [68]	Yinkai Power 20Ah/12V Li-Ion Battery [69]
Manufacturer	Shenzhen	Yinkai Power
Price	\$59.00	\$50.00
Size	Not available	Not available
Key Elements	-Highest Cost -5 Smart security features -Portable -Cycle life of 800 or more times -Greater than 60% of the original capacity	-Lowest Cost -Designed to operate outside -High performance -Low maintenance (no acid or water) -Cycle life of 800 or more times
Part Selected	This battery highlighted was selected due to the specifications, lower costs, lower maintenance and designed to operate in outside conditions.	

3.2.16.1 Shenzhen 20Ah/12V Lithium Polymer Battery [68]

The Shenzhen Lithium polymer battery has a nominal voltage of 12 Volts and 20Ah. It includes smart security features of over-discharge protection, over-current protection, over-charge protection, over-temperature protection and secondary protection. This battery is compatible for applications such as digital products, portable electronics, and electrical applications. It has a cycle life greater than 800 cycles and greater than 60% of the original capacity. The advantages of this battery are the light-weight, portability, and low-costs. This battery costs \$59.00 from Alibaba.com.

3.2.16.2 Yinkai Power 20Ah/12V Lithium Ion Battery [69]

The Yinkai Power Lithium Ion battery has a nominal voltage of 12 volts and 20 Ah. It has a long life, large capacity, good shock resistance, low self-discharge, good discharge performance at low temperatures, strong charging acceptance, quick-charging capabilities, strong over-discharge resistance and charge retention. The advantages of this battery are the low-costs, low maintenance (no acid or water maintenance), environmentally friendly, light weight, and very safe (no explosions or fire). This battery has been through several tests that include the aging test, charging-discharging test, pull out test and the loop test. This battery is compatible for applications such as lights, outdoor sports products, customer electronics, home appliances, electric transportation vehicles, GPS and power tools. This battery has a cycle life of 800 times or more. This battery costs \$50.00 from Alibaba.com. Due to the better specifications, more compatible applications to this project and lower costs than the other batteries compared, this is the battery that will be used in this project as shown below in Figure 33.



Figure 33: Yinkai Power 20Ah/12V Li-Ion Battery used with permission from Alibaba.com [69]

3.2.17 Perimeter Wire Battery Selection

The Perimeter Boundary Battery will power the Perimeter Boundary System. The purpose of this battery is to power the circuit that will send the signals through the perimeter wire to act as a virtual fence. It will mainly need to power the 555 Timer that is generating the square wave output. The Perimeter Wire Battery selection is shown below in Table 42.

Table 42: Perimeter Wire Battery Selection

	DTP 10Ah/12V Li-Po Battery [70]	Great Max 10Ah/12V Li-Po Battery [71]
Manufacturer	DTP	Great Max
Price	\$20.00	\$13.00
Size	As requested	Not available
Key Elements	<ul style="list-style-type: none"> -Highest Cost -Cycle life of 500 times or more -Charge current of 0.5C -Grade A Cells -Designed for outside conditions 	<ul style="list-style-type: none"> -Lowest Cost -Cycle life of 500 times or more 70% DOD -Discharge current of 1C -Designed for outside conditions
Part Selected	This battery highlighted was selected due to the lower costs, specifications, high efficiency and designed to operate in outside conditions.	

3.2.17.1 DTP 10Ah/12V Lithium Polymer Battery [70]

The DTP Lithium Polymer Battery has a nominal voltage of 12 Volts and 10Ah. It has a cycle life of more than 500 cycles. It has a charge current of 0.5C and discharge current of 1C. This battery is compatible for applications such as solar street lamps, emergency starting, VR and other electronic products, digital products and electric scooters. The advantages of this battery are the low costs, portable, light weight, grade A cells, CE certifications, RoHS certifications, FC certifications, UN38.3 certifications and rechargeable. This battery costs \$20.00 from Alibaba.com.

3.2.17.2 Great Max 10Ah/12V Lithium Polymer Battery [71]

The Great Max Lithium polymer battery has a nominal voltage of 12 Volts and 10 Ah. It has a cycle life of more than 500 cycles. It has a discharge current of 1C. This battery is compatible for applications such as electric bikes/scooters, energy storage equipment, digital products, walkie-talkies, lights, tools, and toy cars. The advantages of this battery are the low costs, portable, light weight, high quality, CE certificate, RoHS certificates, UN38.3 certificates, and rechargeable. This battery costs \$13.00 from Alibaba.com. Due to the lower costs, specifications and more compatible applications than the other battery compared, this is the battery that will be used for this project in Figure 34, shown below.



Figure 34: Great Max 10Ah/12V Li-Po Battery used with permission from Alibaba.com [71]

3.2.1 Front Wheels Selection

The front wheels of this project are very important for the overall locomotion of the grass cutter. This will be selected by the Mechanical Engineering Team. They should be capable of navigating through uneven terrain, inclines and declines. The wheel selections should consider wheels with high traction and durability. Additionally, wheel radiuses as weight come into consideration in this section. If DC engines operate at a rate of revolutions per minute (rpm), the wheel radius determines the distance desired to be traveled as well as the resistance torque straining the motor. Weight also adds to this resistive torque straining the engine. The more resistant the wheels from turning, the more energy required from the source to keep the motors turning at a given rpm. If the mower is ongoing in a declined position, governing the wheels may be required determined by the grade of the area being mowed. The selection is shown below in Table 43 by the Mechanical team.

Table 43: Wheel Selection from Mechanical Team

	MaxPower 335100 Lawn Mower Wheel [72]	Arnold Steel Wheel [73]
Manufacturer	MaxPower	Arnold
Price	\$23.59	\$16.77
Size	10-inch diameter	10-inch diameter
Key Elements	<ul style="list-style-type: none"> -1.75-inch thickness -Hard rubber tread -ABS plastic hub -Weights 2.5 lbs. -0.5-inch shaft hole -No air required -Diamond Tread -Plastic Wheel 	<ul style="list-style-type: none"> -1.75-inch thickness -80-pound load capacity -0.5-inch ball bearing in hub -Steel hub -Heavy -Air-filled -Smooth, sturdy ride -Good traction and level cutting for mowers
Part Selected	This part highlighted was selected due to the low maintenance required due to no air required and light weight.	

3.2.2 Caster Wheels Selection

The caster wheels are a vital part of the 360 degree turns the grass cutter will be capable of making. The caster wheels will be selected by the Mechanical Engineering Team. Picking the caster wheel's material is a vital part of for the overall motion of the rover. The caster wheels must also have a large enough diameter for the wheel to roll over uneven terrain, allowing the caster to easily glide over obstacles rather than being driven into the ground. The grass-cutting robot can maneuver frontward and backward with 360-degree rotation; therefore, the caster wheels must be able to spin in any direction without adjusting the other two synchronized wheels too far from their desired positions. The selection is shown below in Table 44 by the Mechanical Team.

Table 44: Caster Wheel Selection by Mechanical Team

	Powertec Swivel Heavy Duty Caster	Ironton Swivel Pneumatic Caster
Manufacturer	Powertec	Ironton
Price	\$19.99	\$22.99
Size	6.25-inch diameter	7.563-inch diameter
Key Elements	<ul style="list-style-type: none"> -2-inch thickness -300-pound load capacity -Hard rubber tread -Precision ball-bearing -Solid rubber wheel -Weighs 5 pounds 	<ul style="list-style-type: none"> -2-inch thickness -200-pound load capacity -Rubber tread -Unpainted Steel Frame -Air-filled wheel
Part Selected	This part highlighted was selected due to the low maintenance required due to no air required and lower costs.	

3.2.4 String-Based Blades and Trimmer Head Selection

The String-Based trimmer head selection will be done by the Mechanical Engineering Team. The customer requires the use of Nylon String-Based Blades due to safety reasons. Having a non-metal blade for the autonomous mower reduces the risk for serious injury. This is shown below in Table 45.

Table 45: String Trimmer Head Selection by Mechanical Team

	Pivotrim Pro String Trimmer	Ball's Home Universal Trimmer Head
Manufacturer	Pivotrim	Ball's Home
Price	\$10.99	\$23.99
Size	4.5-inch Disc Diameter	4.92-inch Disc Diameter
Key Elements	<ul style="list-style-type: none"> -Adjustable string diameter -Fixed string trimmer head -Threaded shaft bore size of M10*1.25 -4-string mounting locations 	<ul style="list-style-type: none"> -Adjustable string diameter -Threaded shaft bore size M10*1.25 -3-string mounting locations
Part Selected	This part highlighted was selected due to its lower costs and more string mounting locations.	

4.0 Related Standards and Design Constraints

A standard is a document that defines the characteristics of a product, process or service, such as dimensions, safety aspects, and performance requirements. Standards are usually an enforceable means to evaluate acceptability and sale-ability of products and/or services. Design constraints are limitations or limits upon certain features or aspects of the project. Since standards are usually enforceable, standards are design constraints, but a design constraint does not necessarily have to be a standard. This project is a combination of numerous components, powered by both software and hardware. The following sections will identify design constraints related to the project, standards related to the project, and additional design constraints that arise from the previously mentioned standards.

4.1 ABET Design Constraints

According to the ABET Design Requirements, students in Senior Design should be able to attain an ability to design a system, components, or process to meet desired needs within the realistic design constraints. These realistic design constraints, named: time, economic, environmental, weight, size, ethical, health and safety, manufacturability, and power, are design constraints that must be addressed when it comes to designing the autonomous grass cutter. This includes finding information on the design constraints in professional publications in the areas related to this project. These mentioned design constraints and their relation to the project will be described in the following sub chapters.

4.1.1 Time Constraints

This project will span a design and development time of around 30 weeks – from September 2018 to April 2019. This time constraint is calculated from the length of a typical semester where this project will span two semesters with a one month break in between. Within this timeframe, the autonomous grass cutter must meet additional time constraints, such as the competition between all involved teams and their autonomous grass cutters as was the intent of the sponsors, Duke Energy and Orlando Utility Commission.

While the competition does not currently have a set date, it is expected to occur within April. Shortly after the competition, the project must be presented to a panel of University of Central Florida (UCF) professors for an evaluation of the project's design and performance. The project must have a working prototype prior to the competition and presentation.

4.1.2 Economic Constraints

Economic design constraints affect overall project expenses. The sponsor has limited the project to \$1,500 dollars. Although researching is usually free, component testing and prototyping may also cut into the budget before a working prototype is complete. In order to reduce any unrecoverable losses from the budget from situations such as part failure or change of part selection after order, it is imperative that as much research as possible be completed. Having the most information, comparisons, and components available that fit

within the following design constraints will allow for the project to have unrecoverable expenses, such as the ones previously mentioned, minimized. The project itself should not exceed the sponsor's budget, nor should the cost to build a working prototype. While maintenance costs are not factored into the budget, research will be done so that components and parts are chosen with a sense of longevity.

4.1.3 Environmental Constraints

Environmental design constraints refer to the physical surrounding environment and conditions that will affect the performance of the grass cutter. The environment of the grass cutter will be outside on solar farms that consists of uneven terrains. Narrowing the scope of outside environment down to the average of the state of Florida, the grass cutter will have to endure environmental conditions where the average temperature ranges from 50 to 110 degrees Fahrenheit, humidity averages 70% daily and rain occurs an average of 1 out of every 3 days. Heat, humidity, and water affect the performance of batteries and electronics.

The prototyping environment will be indoors at roughly 70 degrees Fahrenheit. While the final prototype may be built to withstand all environmental conditions, the base requirement for this iteration of the project is that the working prototype be able to meet functional requirements in an environment that is assumed to be always sunny, never raining, and 70% humidity. Also, the terrain differential has been giving a floor of roughly 3 inches by the sponsor; meaning that the grass cutter shall have functionality up to a height differential of 3 inches on each side of the wheels.

4.1.4 Weight Constraints

Weight design constraints affect the overall performance of the grass cutter. It is obvious that the weight of the grass cutter has an inverse relationship to the longevity and efficiency of the grass cutter. As the grass cutter becomes heavier, the battery must provide a greater amount of force to maintain the same speed when compared to a lighter grass cutter. Also, the rear caster wheel may get stuck if the grass cutter becomes too heavy.

Since most electrical components that will be designed or chosen, such as the printed circuit boards or chips, will be light, only the major components, such as the batteries, must be considered by the electrical engineering team when it comes to weight design constraints. Lithium-ion batteries offer the greatest energy density per weight, but then economic design constraints must be considered because of their cost. Lead-acid batteries offer the best economic solution in terms of energy density per dollar, but they also weight the most, affecting the weight design constraints.

The overall weight of the grass cutter will be a combination of the materials and parts designed by both the mechanical and electrical engineering teams. Materials have tradeoffs between durability and weight that may require consideration. The weight must be considered carefully to ensure the overall locomotion, longevity, and efficiency of the grass

cutter. The ideal situational would be for the lightest possible parts to obtain the highest amount of operation time for the grass cutter per charge.

4.1.5 Size Constraints

Size design constraints affect the design of the grass cutter. While size design constraints mostly affect the mechanical engineering team, the electrical engineering team must consider the size design constraints when it comes to sensor placement. The size design constraint is 2 cubic feet, imposed and enforced by the sponsor, Duke Energy and Orlando Utility Commission. The 2 cubic feet size design constraint was created because the grass cutter must navigate through a solar farm without risking damage to any of the solar farm's infrastructure.

An additional size design constraint is imposed by the sponsor's requirement for the grass cutter to maintain grass to a height between 3 to 6 inches. Although the grass cutter will have wheels that touch the ground, a string-based blade must be able to cut grass down that is possibly above 3 to 6 inches. Since the motors will most likely be mounted in a "top down" configuration, it is safe to assume that the motors will be coming out from the bottom of the frame designed by the mechanical engineering team.

With the two previously mentioned size design constraints and the grass cutter design considered, they must be minimized in order to satisfy both mentioned size design constraints. Having the grass cutter satisfy both mentioned size design constraints will allow clearance below and around PV panel structures on the solar farm. Finally, to ensure clearance of PV panel structures, it was decided to give an additional 6-inch height clearance to the grass cutter meaning that the final design size is aimed to be at 2 feet in length, 2 feet in width, and 18 inches in height.

4.1.6 Ethical Constraints

Ethical design constraints affect the overall product integrity for the autonomous grass cutter. Ethical design for electrical engineers focuses on compliance with laws and regulatory codes, sustainability in various aspects, and service to the public good. Since the culmination of this project results in a competition between multiple engineering teams from both the University of Central Florida and the University of South Florida, ethical design constraints also include consideration of upholding a sense of fair play between opposing teams. Product integrity, or ethical design implies that the autonomous grass cutter would be delivered functioning and operating to the requirements at a minimum. Ethical design also includes the ethical practice of being transparent about design pitfalls or requirements not meant even though the cause could be from limitations of resources or from other constraints.

Part of ethical design begins with the choosing of parts and components. Considering the competition, it would be unethical to use parts out of budget to gain an advantage. For example, an unethical case would arise if more expensive and capable parts were used on the prototype but were out of the budget of a similar team. Another ethical design concern

arises when it to choosing parts and components; if the parts or components themselves are ethical. The choosing of ethical parts or components is critical for the project because the consequence of using an unethical part could mean that the prototype is not allowed to operate, thus making the prototype useless and nonfunctioning. Selecting commercial parts and components assures that standardized processes are met and that this portion of ethical design is met.

A constraint imposed by ethical design is that the operations of the grass cutter needs to be designed in a way the minimizes risk and disturbance to nearby life and minimizes possible damage to the grass cutters surrounding environment. An example of minimizing risk to nearby life would be to design the grass cutting blades to have a guard that stops unintended cutting. The example previously mentioned imposes an ethical design constraint because the design of a guard is then required for the cutting blades, thus adding weight and complexity to the overall design of the cutting assembly. This project achieves ethical design by designing around the environment of the solar farm. It is possible that critters or wild life can encounter the grass cutter. An ethical design constraint is that the prototype must have a design that does damage equipment and minimizes risk and disturbance to nearby life. Since the grass cutter is required to have autonomy, decisions must be made without human intervention. Considering the information given by computer vision, its sensors, and any other inputs such as time of day (if tracked), the grass cutter must make ethical decisions without human intervention (definition of autonomy). To employ an ethical design when it comes to the operation autonomous grass cutter mostly comes down to the programming of the grass cutter. As the grass cutter traverses and encounters obstacles, it must be programmed to prioritize the safety of the environment prior to cutting the grass. This ethical design constraint means that fail safes or protocols must be implemented into the programming of the autonomous grass cutter to safely operate within the solar farm environment.

Once the ethical design constraints are addressed in the design and programming of the autonomous grass cutter, an ethical design will be achieved. Having an ethical product ensures the integrity of the product. Customers trust that engineers design a product with high integrity to ensure the functionality and safety of the product. The Mission of The IEEE Global Initiative on Ethics of Autonomous and Intelligent Systems is “To ensure every stakeholder involved in the design and development of autonomous and intelligent systems is educated, trained, and empowered to prioritize ethical considerations so that these technologies are advanced for the benefit of humanity.”

4.1.7 Health and Safety Constraints

Health and safety design constraints affect the overall capability of the grass cutter. The underlying objective of the autonomous grass cutter is to remove the need for human labor to maintain a solar farm’s vegetation levels, thus removing any possible human injury when it comes to mowing grass in the Florida environment, there are still health and safety design constraints that affect the grass cutter. It is imperative that the grass cutter fulfill all its requirements, such as cutting grass, but the safety and health of the grass cutter’s surrounding infrastructure and environment must be considered. Although a solar farm

does not usually have humans nearby, a human must interact with the grass cutter to start and stop it. Human well-being is of the highest priority for this project's health and safety design constraints. Along with human well-being, the grass cutter must be designed with other forms of life, such as animals, in mind.

Batteries impose a health and safety design constraint. Batteries use dangerous chemicals to store energy and it is possible for a battery to start a fire or leak the previously mentioned dangerous chemicals upon failure. Understanding that humans and animals will possibly interact with the grass cutter is important when it comes to considering what components to use and how to program the grass cutter.

In order to reduce risk of serious injury to humans and animals, the sponsor has required a health and safety design constraint of using only string-based blades on the grass cutter. Opting to use a string-based blade instead of a metal blade to cut grass imposes possible longevity and maintenance issues to the grass cutter but is necessary as a failsafe incase built in algorithms and methods fail.

4.1.8 Manufacturability Constraints

Manufacturability design constraints apply to the reproducibility of the grass cutter. Since the grass cutter is designed to be a revolutionary method to vegetation growth control over human labor, one prototype will not be enough to address any possible consumer demand in the future. By using a combination of off the shelf hardware and having readily available schematics, it will be possible for the sponsors to redesign or manufacture the grass cutter once complete.

Having batteries in the grass cutter device imposes a manufacturing design constraint. Depending on the type of battery, the grass cutter may not be able to be flown on via airplane. While it is possible to have the grass-cutter designed to have a replaceable battery so that a battery could be "dropped in" when the grass cutter reaches its destination, the engineering design's focus is on functionality and a "drop in" capability would be an afterthought once a working prototype is created.

The manufacturing industry with the use of CNC (Computer Numerical Control) Machinery has the capability to cut, drill, and bend different types of materials. For every manufacturing data sheet there are marginal errors specified. While manufacturing constraints for electrical components involve voltages, currents, watts, etc. other measurements of hole diameter, metal softness, depths, etc. in 3D Solid Works or CAD (computer aided design) modeling for the mechanical engineers are where a cost constraint due to the manufacturing process primarily is. As stated previously, off-the-shelf hardware will reduce the cost in immediate regards of cost to the grass-cutter project. However, when building a structural model for the grass-cutter, specs of marginal error limitations are required by and given to the manufacturer. The difficulty of drilling a 5-inch hole of a small diameter in a softer metal with a marginal error set to .1 mm will cost a small fortune of design. It is left to the mechanical team not to design difficult parts for the manufacturer to take time 'cutting.' Machine time is the overall factor that needs minimized to maintain a

cheap source; next is the material itself. The electric grass-cutter must be durable, and the required parts in design cannot take an abundant amount of CNC machine time to produce. The more time it takes, the more expensive the product will become. This creates a manufacturing constraint if the product is ever going to be mass produced.

4.1.9 Power Constraints

Power design constraints affect the longevity and efficiency of the autonomous grass cutter. How long the grass cutter can cut the grass on one full charge is important because it sets the time limit that the grass cutter is effectively doing its job of cutting. Different quantifiable power constraints arise depending on the choice of battery used for the autonomous grass cutter. Not only will previously mentioned constraints, such as economic, environmental, weight, and size affect the decision of the battery used for the project, but the same mentioned constraints will become an additional factor towards considering the longevity and efficiency of the autonomous grass cutter. Battery standards identified and explained upon in the standards section of this documentation provided a good place to reference to address current power constraints.

The design of the autonomous grass cutter will most likely implement interconnects that act as voltage regulators. Voltage regulators supply power to the various systems used within the robot, however it comes with a cost. The use of voltage regulators will contribute to power loss within the robot. No circuit can be 100% efficient and with semiconducting devices in the ICs that construct the voltage regulators, power loss will be established in ground currents and voltage drops over transistors. Multiple design approaches can be designed, viewed and selected using the Texas Instruments Webench tool. Today, power design trade-offs factor into production more significantly than ever. As time moves forward, evolved technologies will prefer a high fraction power factor. In China a minimum power factor for energy conservation is already established. It is possible that many other countries around the world can follow suit and establish their own minimum requirements for a power factor to enforce energy conservation. Power constraints not only relate to performance but also to where in the world the product can be sold and used. Minimum power factor or power efficiency regulations aren't currently required by United States federal law.

Lastly, another consideration of ethical constraints imposes a power constraint. Renewable energy solutions are used to save resources and prevent global warming. One of the purposes of providing solar energy farms with an electric grass-cutter solution is to further conserve energy. Batteries are perceived to reduce the amount of fossil fuels needed to power an engine, however many do not consider the source of what is providing charge to the batteries. Unless the battery is recharged using the infrastructure of the solar farm, it most likely will be charged using power provided by a local power station. A case of ethics in terms of power constraints arises because most local power stations still burn fossil fuels to provide power to its area of responsibility. Having a fossil fuel powered autonomous grass cutter responsible for vegetation control of a renewable or alternative energy solar farm does not make ethical sense. This issue is further magnified depending on the power factor or power loss the autonomous grass cutter ultimately has.

As previously mentioned, power design constraints affect the longevity and efficiency of the autonomous grass cutter. The combination of previously mentioned constraints, such as economic, environmental, weight, and size will affect the decision of the battery used for the project, but the same mentioned constraints will become an additional factor towards considering the longevity and efficiency of the autonomous grass cutter. The use of voltage regulators will contribute to power loss within the robot. Tradeoffs between efficient and economical interconnects will ultimately decide the power factor, which could affect manufacturability.

4.2 Standards

A standard is a document that defines the characteristics of a product, process or service, such as dimensions, safety aspects, and performance requirements. Standards are usually an enforceable means to evaluate acceptability and sale-ability of products and/or services. Standards are usually formed by committees or communities, known as Standards Development Organizations (SDOs), that specialize in a specific product, process or service. Some of the most well-known SDOs are; the Institute of Electrical and Electronics Engineers Standards Associated, the International Standards Organization, the International Electrotechnical Commission and the International Special Committee on Radio Interference.

By adhering to the standards created by SDOs, more focus can be done on the overall design of the project itself and priority can be assigned to operability or functionality. Recognizing and adhering to standards provides a mutual assurance and protection for engineers and customers alike. Engineers are protected because when it comes to part selection, a part is guaranteed to have a capability that is at least the minimum of the standard. Customers are protected because they are guaranteed that the product that they buy will fulfill at least the minimum requirements for a standard to be adhered to.

Having standards allows for either a designer or customer to choose a specific capability that a standard requires for a certain product, process or service, and to trust that if they purchase a product that adheres to any applicable or desirable standards, that the product, process, or service will work as intended. Using parts or components that meet the standardization process means that the autonomous grass cutter should safely operate within the environment of a solar farm.

4.2.1 IEEE Standards

The Institute of Electrical and Electronics Engineers (IEEE) Standards Association provides a wide range of technical and geographic points of origin to facilitate standards development and standards related collaboration. IEEE is one of the biggest publishers of standards, especially in the subject of electronics. IEEE forms committees to decide how a product, process, or service should be standardized. The IEEE standards related to this project will be described in the following sub chapters.

4.2.1.1 Battery Standards [74] [75]

The battery standards that apply to this project are the IEEE 1679.1 and IEEE 1625. IEEE 1625 guides manufacturers and suppliers in planning and implementing the controls for the design and manufacture of lithium-ion and lithium-ion polymer rechargeable battery packs. IEEE 1679.1 guides the rechargeable electro-chemistries with lithium ions and lithium-ion polymers as the active species exchanged between the electrodes during charging and discharging. Technology description information on aging and failure modes, safety issues, evaluation techniques and regulatory issues are also standardized in IEEE 1679.1.

The use of rechargeable lithium-ion and lithium-ion polymer batteries apply to this project. Battery standards exists in regulation of fire and safety codes. By law, in different states the disposal of batteries is regulated as well. Local battery retailers are paid to accept used batteries for recycling to avoid pollution to the environment. Due to a significant negative impact on the environment once disposed of, batteries are regulated to assure that, once manufactured, the costly process to store the energy inside a battery is minimized. Battery cells storing potential voltage are designed to maintain stability at different temperature standards as well.

4.2.1.2 C Language Standards [76]

Standardized by a joint effort between the International Organization for Standardization (ISO) and the International Electrotechnical Commission (IEC), the C language for programming offers multiple benefits towards this project, such as simplicity and portability. Since the C programming language has had multiple revisions to its standardization, it is fundamental to understand which revision that this project must adhere to. Formally called ISO/IEC 9899, the C language currently has 3 majorly used revisions that have different trade-offs. As this project may utilize either of the 3 standards, it is important to understand each of them. Each revision has an informal name, released chronologically in the following order: C99, C11 and C18.

In time, C language standards have been modified to include many libraries, functions and I/O options that allow users to easily implement and design complex codes. Most importantly is that these standards are followed and enforced by compilers. Since most major compilers will not allow deviation from a standard, the only thing that must be verified is that the desired C language standard is chosen in the compiler. Most revisions envelop the previous revisions in terms of capability, however an older revision may be chosen for applications where memory is limited or smaller libraries. For example, it is possible that a compiler that is compiling with a newer C standard uses more lines of code to implement a code than an older C standard. An older C standard could be chosen for system designs where memory is a limited resource.

4.2.1.3 Wireless Standards

The wireless standards that apply to this project are a part of the IEEE standard 802.11, versions: 802.11b, 802.11g and 802.11n. IEEE standard 802.11 is a set of media access

control (MAC) and physical layer (PHY) specifications for implementing wireless local area network (WLAN) computer communications in specified frequencies. Any device that uses wireless communications today must adhere to IEEE standard 802.11. IEEE standard 802.11 is created and maintained by the IEEE local area network and metropolitan area network (LAN/MAN) standards committee, also known as IEEE 802.

While the previously mentioned 802.11b, 802.11g and 802.11n are amendments to the original 802.11 standard, the industry and commercial world usually refer to the revisions individually because they have standardized capabilities. Table 17 in section 3.1.12 “Wireless Communications” lists three of the amendments/versions that are of interest for the project because of their capabilities. Understanding that the goal of having the grass cutter maintain the most area possible, range is of a priority over data rate.

The highest range wireless standards were chosen to be implemented over standards that are capable of higher data rates because most of the data sent, whether it is for a kill switch or an operating system application, will most likely be parameters from the autonomous grass cutter and not something data intense, such as video streaming (although it may still be capable of video streaming). The 802.11 standard suite and its respective amendments also specify what frequency the wireless local area network will be communicating at. A most likely case for this project is that it will be transmitting and receiving on a 2.4 gigahertz (UHF) radio frequency band, unless 5.8 gigahertz (SHF) is chosen under the 802.11n standard.

4.2.1.4 Software and Systems Engineering- Software Testing

Software testing has been standardized by a joint effort between the International Standards Organization (ISO), the International Electrotechnical Commission (IEC) and the IEEE. This joint effort of standardization for software testing has resulted in the formal standard named ISO/IEC/IEEE 29119. Since the autonomous grass cutter may implement computer vision or interfaces through an application via an operating system, it is most likely that software will be integrated into the project. Software creation or testing will most likely be handled by the computer science team however, it may be possible that the electrical engineering team will create or test software. Software testing on this project will adhere to the international standards in ISO/IEC/IEEE 29119. ISO/IEC/IEEE 29119 is a series of five international standards for software testing, where part 1 through 5 is named ISO/IEC/IEEE 29119-1 through ISO/IEC/IEEE 29119-5. The entire ISO/IEC/IEEE 29119 suite is a standardized process for testing software.

Part 1 facilitates the use of the other parts of the standards by introducing the vocabulary on which the rest of the standard will be using. It provides a description of the concepts to software testing, standardized definitions, and how to navigate the other parts of the standard by applying the definitions and testing concepts. [77]

Part 2 of ISO/IEC/IEEE 29119 defines a general model for software testing that is intended to be used when performing software testing. The model specifies test processes that may be used to manage and implement software testing in an organization, project, or any

general testing activity. The testing process is based on a three-layer process model that covers organizational test specifications, test management, and dynamic testing. The standard uses a risk-based approach to testing, specifying that a risk-based approach is the best-practice approach to strategizing and managing testing. Using a risk-based approach for software testing on the project means that the most important features (the requirements) are prioritized and ensures that the software meets requirements using the most efficient process possible. [78]

Part 3 of ISO/IEC/IEEE 29119 focuses on defining templates for test documentation to cover the entire life cycle for software testing. The templates provided in the standard can be tailored to suit the unique needs for the project while also implementing the standard. Having the project’s documentation follow a standardized template will ensure that processes and tested are properly recorded or documented. [79]

Part 4 of ISO/IEC/IEEE 29119 defines an international standard covering software test design techniques. These software design techniques, also known as test methods, can be used during the test design and implementation process for the project. The test methods in part 4 incorporate the risk-based approach that is described in part 2 of the standard. The test design techniques that are presented in this standard can be used to derive test cases and collect evidence for the project to prove that a requirement has been met by a certain software. [80] Part 5 of ISO/IEC/IEEE 29119 addresses test automation which does not apply to this project in terms of software testing. [81] The five standards are shown below in Table 45.

Table 46: ISO/IEC/IEEE 29119 Standards

ISO/IEC/IEEE International Standard - Software and Systems Engineering - Software Testing Suite (29119)	
29119-1	Part 1: Concepts and Definitions
29119-2	Part 2: Test Processes
29119-3	Part 3: Test Documentation
29119-4	Part 4: Test Techniques
29119-5	Part 5: Keyword-Driven Testing

4.2.1.5 Robot Map Data Representation for Navigation Standard [82]

Since navigation will be done autonomously by the grass cutter, a form a mapping must be integrated into the grass cutter. IEEE has acknowledged and standardized the way that which a robot’s map data for navigation is represented with “1873-2015 – IEEE Standard for Robot Map Data Representation for Navigation.” Although the topic of mapping for robots is very broad when considering that there are multiple methods of which an autonomous robot can implement to map an area, the standard provides a scope of what exactly is being standardized so that a clear process is identified and explained. IEEE 1873-2015 is used for defining terminologies related to 2D robot maps of navigation in both indoor and outdoor environments. IEEE 1873-2015 specifies a data model for each

possible element and defines a format to exchange the previously mentioned data model among computers and other robots.

The importance of IEEE 1873-2015 is that the way robot mapping data is represented has become standardized. This standardization of robot mapping data allows an accessible use of software exchange among other robotic systems which expands the range of application and operational use among robots. The standard contains a section of definitions as well as a section of mathematical definitions for a reader to use this standard and understand the terms or models presented within the standard. Within the standard there are several tables labeled with either an “M” or an “O”, where “M” stands for mandatory and “O” stands for optional. IEEE 1873-2015 provides detailed descriptions for how to format mapping data between different types of mapping, such as metric or topological mapping.

Using the definitions and math models provided in the standard, the standard itself specifies that the XML language will be used to transfer mapping data among computers or other robot systems. The standard explains that XML is a platform-independent language that is accessible across multiple operating systems and that XML language stores files in a human readable format. IEEE 1873-2015 is important because having the mapping data standardized means it is transferrable between computer systems or other robotic systems. Adhering to the IEEE 1873-2015 standard addresses a manufacturing constraint in that it may be possible to preload a map into the grass cutter prior to deployment or first operation. Having the ability to preload mapping data onto the grass cutter opens the possibility of not requiring a physical boundary wire, however this project will not be exploring this possibility until bare functionality requirements are met.

4.2.2 Robotics Standards [83]

The field of robotics is a product of the quickly evolving technologies in modern times. Although the field of robotics is hard to standardize because of the vast range of tasks a robot can complete, the International Organization for Standards or ISO, has created a committee, known as technical committee 299, to standardize the field of robotics. According to ISO 8373, a robot is defined to be an “automatically controlled, reprogrammable, multipurpose manipulator, programmable in three or more axes, which can either be fixed in place or mobile for use in automation applications. By the definition of a robot in ISO 8373, the autonomous grass cutter is a robot. Thus, it is required that the robot standards that apply to this project be identified and followed.

Table 47 below identifies the applicable ISO/TC 299 robot standards that apply to this project. The titles of the released standards are included to provide the scope of each applicable standard. Most of the robot standards that apply to this project are related to locomotion, navigation and safety. These standards do not necessarily express how a robot must behave, but instead the standards present criteria that the robot must meet to achieve a certain process or functionality. The ISO/TC 299 Robotic standards are shown below in Table 47.

Table 47: ISO/TC 299 Robotic Standards

ISO Standard	Release Year	Standard Title
ISO 8373	2012	Robots and robotic devices -- Vocabulary
ISO 9283	1998	Manipulating industrial robots – Performance criteria and related test methods
ISO 9787	2013	Robots and robotic devices – Coordinate systems and motion nomenclatures
ISO 10218-1	2011	Robots and robotic devices – Safety requirements for industrial robots – Part 1: Robots
ISO 10218-2	2011	Robots and robotic devices – Safety requirements for industrial robots – Part 2: Robot systems and integration
ISO 18646-1	2016	Robotics – Performance criteria and related test methods for service robots – Part 1: Locomotion for wheeled robots

4.2.3 Inter-Integrated Circuit (I2C) Standards

To reduce the complexity and cost of connecting the embedded systems and peripheral devices such as sensors, the I2C bus may be utilized. I2C is a flexible serial bus solution that has been standardized by the company “NXP Semiconductors” (previously known as “Phillips Semiconductor”). The I2C serial bus is used to provide intra-board lower-speed peripheral interconnects to processors and microcontrollers. NXP Semiconductors has released multiple revision to the I2C bus specification with the latest version being version 6, released in April 2014.

4.2.4 Universal Serial Bus (USB) Standards

This project may implement the use of USB to interconnect certain peripheral devices or sensors. This document identifies any applicable USB standards to ensure that the project adheres to any of the standards identified. Following applicable standards ensures that all interconnected peripheral devices or sensors will communicate using the same protocols.

USB standards are created by the Universal Serial Bus Implementers Forum, also known as USB-IF, and enforced by the International Electrotechnical Commission (IEC). Any time there is a change in a USB standard, USB-IF submits documentation for changes to be implemented into IEC’s documentation. Like the wireless standard IEEE 802.11, every amendment to the USB standard is usually referred to as its name. For example, USB version 3.2 is referred to as USB 3.2. USB 3.2 is the most up to date version of the standard, however USB 2.0 is still the most common as of today. Although USB 2.0 is the most common, USB 3.2 has the highest data capability. Since it is most likely that any peripheral devices or sensors used on the project will be using, USB 2.0, USB 3.2 or any USB version in between, the standards that are applicable are mentioned in this section.

IEC 62680 refers to an entire suite of USB standards ranging from definitions, to components, to specifications. IEC 62680 is a series of eight international standards broken into three parts for the USB, where specifications are defined for the various versions of USB. Table 48 below lists the entire IEC 62680 suite which includes all three parts. The project will ensure that peripheral devices or sensors that require the USB are interconnected using the international USB standards listed in the IEC 62680 suite. This is shown below in Table 48.

Table 48: International Electrotechnical Commission 62680 Universal Serial Bus Standards Suite

IEC Standard	Year	Standard Title
62680-1-1 [84]	2015	Part 1-1: Common components – USB Battery Charging Specification
62680-1-2 [85]	2018	Part 1-2: Common components – USB Power Delivery Specification
62680-1-3 [86]	2018	Part 1-3: Common components – USB Type-C™ Cable and Connector Specification
62680-1-4 [87]	2018	Part 1-4: Common components – USB Type-C™ Authentication Specification
62680-2-1 [88]	2015	Part 2-1: Universal Serial Bus Specification
62680-2-2 [89]	2015	Part 2-2: Micro-USB Cables and Connectors Specification
62680-2-3 [90]	2015	Part 2-3: Universal Serial Bus Cables and Connectors Class Document
62680-3-1 [91]	2017	Part 3-1: Universal Serial Bus 3.1 Specification

4.2.5 Electromagnetic Compatibility (EMC) Standards

Electromagnetic compatibility is a branch of electrical engineering that addresses the concern of unwanted effects, such as electromagnetic interference or damage to other electronic equipment, caused by unintentional generation, propagation and reception of electromagnetic energy. The focus of electromagnetic compatibility is the harmonious operation of different equipment within an electromagnetic environment. The autonomous grass cutter must meet EMC standards outlined by applicable SDOs. EMC has three classes; Emission, susceptibility, and coupling.

Emission is the generation of electromagnetic energy from an electronic device that releases into its surrounding environment. Since the autonomous grass cutter may utilize AC power, DC, power or a combination of both AC and DC power, it is highly likely that the grass cutter will have electromagnetic emissions. These electromagnetic emissions could possibly damage the electronic equipment required for solar farm operation. It is also possible for the solar farm’s electronic equipment to emanate electromagnetic energy into the grass cutter’s electronics. Additionally, the use of wireless communications requires the emissions of electromagnetic energy. Having a requirement for an independently powered location device on the grass cutter means that some form of wireless communication will be used. Since wireless communication uses low power, the

only concern when it comes to interference would be the attenuation of communication signals between the solar farm and grass cutters electrical equipment. The Federal Communications Commission (FCC) addresses any concern of signal attenuation by standardizing the frequency spectrum. Between the standardization of frequency use and 802.11 signaling protocols, wireless communication is possible using electromagnetic energy without interfering with other electronic equipment.

Susceptibility refers to how prone a piece of electronic equipment is to malfunction or damage when experiencing nearby electromagnetic energy emissions. It is important that both the grass cutter and the solar farm electronic equipment not be susceptible to any possible emissions from each other to ensure longevity and operability of both the grass cutter and solar farm electronic equipment. EMC uses the term “Immunity” to refer to a piece of electronic equipment’s ability to correctly function in the presence of electromagnetic interference. It is ideal to have the grass cutter and solar farm equipment be immune to each other’s electromagnetic emanations. Since the grass cutter is utilizing a form of electromagnetic emission (wireless communications), the grass cutter must be immune to any interference from the solar farm electrical equipment, but also susceptible to emissions necessary for wireless communication. The mechanism or method by which emitted electromagnetic interference travels to an electronic device is referred to in EMC as coupling. Unless there is a direct connection, almost all coupling will be done through the dielectric of the air in the environment.

By adhering to the EMC standards created by the SDOs, there is an understood underlying assurance that the grass cutter and solar farm electronic equipment will operate as intended. Table 49 below list all applicable EMC standards for this project. Along with identifying all applicable EMC standards, Table 49 below will also identify the SDO, the release year and the standard’s title. Not listed in Table 49, but still applicable is the Federal Communications Commission (FCC) Part 15 under Title 47 of the Code of Federal Regulations which covers EMC for unintentional and intentional radiators. The applicable EMC standards are shown below in Table 49.

Table 49: Applicable EMC Standards

Standard	Release Year	Standard Title
CISPR 14-1 [92]	2016	Electromagnetic compatibility – Requirements for household appliances, electric tools and similar apparatus – Part 1: Emission
CISPR 14-2 [93]	2018	Electromagnetic compatibility – Requirements for household appliances, electric tools and similar apparatus – Part 2: Product family standard
IEC 61000-6-3 [94]	2006+AMD:2010	Electromagnetic compatibility – Part 6-3: Generic standards – Emission standard for residential, commercial and light-industrial environments
IEC 61000-6-4 [95]	2018	Electromagnetic compatibility – Part 6-4: Generic standards – Emission standard for industrial environments

4.2.6 Institute for Printed Circuits (IPC) PCB Standards

The design, production and assembly of a printed circuit board (PCB) is standardized by the IPC. Presently called the Association Connecting Electronics Industries, IPC develops standards collaboratively with the following; IPC members, academics, government agencies, original equipment manufacturers, and electronic manufacturing firms. The IPC's goal is to standardize the assembly and production requirements of electronic equipment and assemblies. The regulated standards that commercial PCBs follow ensure the reliability and longevity of products that utilize electronic equipment. IPC standards apply to all types of printed circuit boards, such as single-sided, double-sided and multilayer. IPC's standard includes all topics related to the printed circuit board including, design specifications, material specifications, material standards, flex assembly, performance and inspection documents, and general documentation. The design, manufacture and integration of the PCBs used in the autonomous grass cutter must meet the standards outlined by the IPC.

Since the requirement of Senior Design for electrical engineers at the University of Central Florida is to design a PCB, the electrical engineering team will design the major PCBs that will interconnect the electronic devices within the autonomous grass cutter. IPC has standardized the process of printed circuit board design by releasing multiple standards that address design specifications of PCBs. By designing to IPC's standards, the schematic can be sent to electronics manufacturing service firm (EMS) to be built. IPC has also standardized the process of building the PCB for an EMS to follow. Once the PCB that is designed by the electrical engineers has been built by the EMS, the PCB is sent back to the engineers for integration into the autonomous grass cutter. Figure 33 below depicts the flow of how a PCB will be designed by the electrical engineers, built by the EMS, and integrated into the autonomous grass cutter according to IPC's standards. The flow depicted in Figure 35 also identifies applicable IPC standards along the PCB designing life cycle.

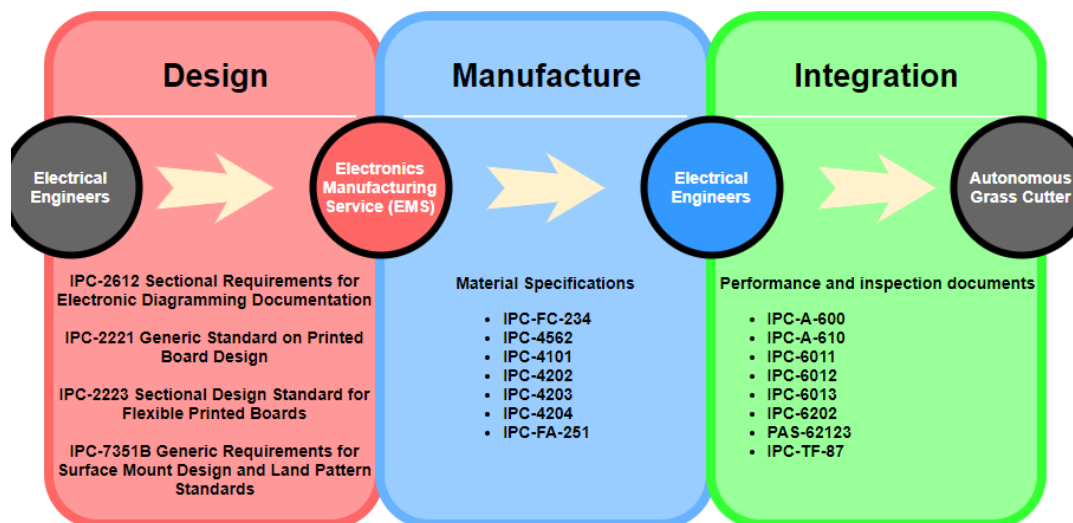

Figure 35: Flow of PCB Design and Implementation made by Christopher Entwistle

5.0 Overall Integration, PCB Design and System Testing

This section describes and shows the overall integration of the hardware and software, the PCB designs and the system testing of the major components.

5.1 Hardware Design

The hardware design refers to the electrical and mechanical components that will be used to for overall motion control, obstacle detection, obstacle avoidance, power design, overall locomotion, and electrical design. This section will display information for each subsystem.

5.1.1 Initial Design Architectures and Related Diagrams

The block diagram shown below shows the overall system and power control. The green lines are the bi-directional power and control lines, the red lines are the one-way power and control lines and the blue dashed lines are the bi-directional control lines. The electrical component's battery powers the ATmega2560 and the Raspberry Pi 3 Model B through a LM2596 Voltage Regulator that takes the unregulated 12 Volts from the battery and regulates it to a 5 Volts output. The Raspberry Pi powers and communicates with the Night Vision Camera and the Wireless Chip. It also communicates with the ATmega2560. The ATmega2560 powers and communicates with the Ultrasonic Sensors, Perimeter Wire Receiver Circuit, GPS/compass module and the L293DNE Motor Driver Chips. It also communicates with the Raspberry Pi Board. The Motor's battery powers the DC Motors through the L293DNE Motor Driver Chips through a LM2596 Voltage Regulator that takes the unregulated 12 Volts from the battery and regulates it to a 12 Volts output. The Motor's battery is connected to a battery charge sensor. The updated Hardware Block Diagram of the grass cutter system is shown below in Figure 36.

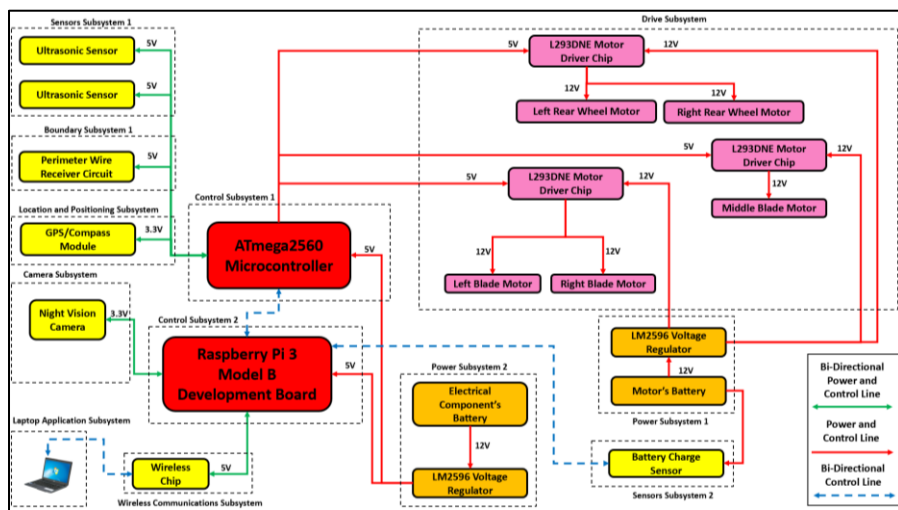

Figure 36: Updated Hardware Block Diagram of the Grass Cutter System made by Brandei Dieter

The Perimeter Wire Battery powers the Perimeter Wire Generator Circuit through a LM2596 Voltage Regulator that takes the unregulated 12 Volts from the battery and regulates it to a 5 Volts output. The Perimeter Wire Generator Circuit produces a square wave that the Perimeter Wire Receiver Circuit will detect. This detection will send an interrupt signal to the ATmega2560 that the grass cutter has reached the boundary of the area. The updated Hardware Block Diagram of the Boundary System is shown below in Figure 37.

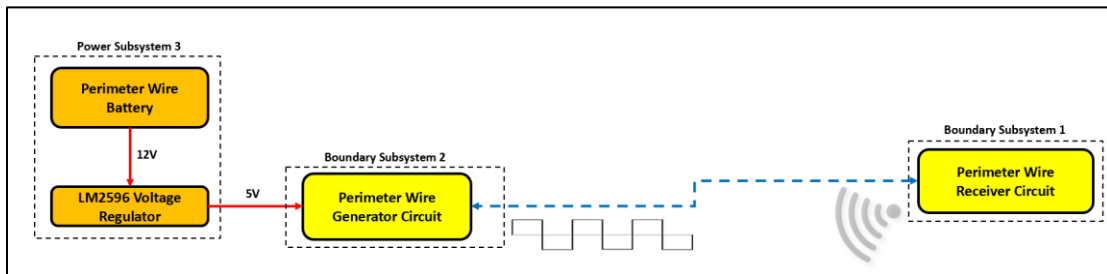

Figure 37: Updated Hardware Block Diagram of the Boundary System made by Brandei Dieter

5.1.2 Sensors Subsystem 1

The Sensors Subsystem 1 will include the two ultrasonic sensors. This will be designed and implemented by the ECE team. They will be used for obstacle avoidance, obstacle detection and measuring the distance from an object to the grass cutter. The design of the Ultrasonic Sensors on the grass cutter robot is shown below in Figure 38.

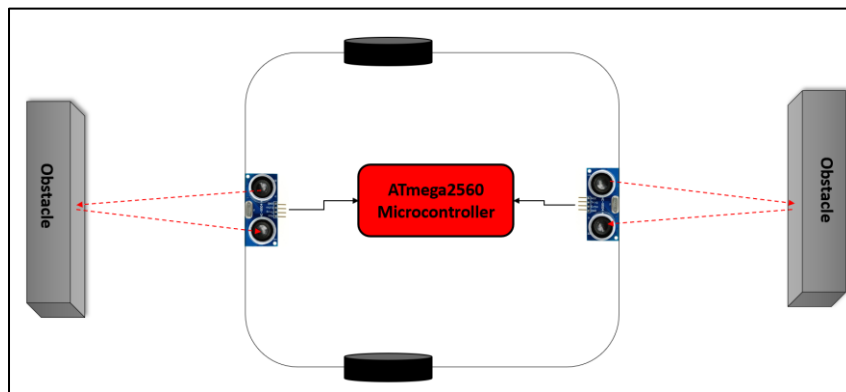

Figure 38: Sensors Subsystem 1 Design made by Brandei Dieter

5.1.3 Location and Positioning Subsystem

The Location and Positioning Subsystem will include the GPS/compass module. This will be designed and implemented by the ECE team. It has a 3V lithium ion backup battery, so it can operate for a defined period after the main batteries have been completely drained to ping the location of the robot. The GPS/compass module will provide the grass cutter system with the location and position of the robot. The GPS/compass module will communicate with the ATmega2560 and that information will also be routed through the

Raspberry Pi 3 Model B through the wireless chip to send the data to the laptop application. This system is shown below in Figure 39.

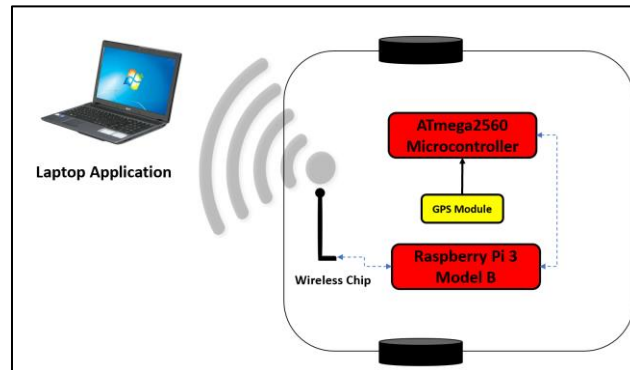

Figure 39: Location and Positioning Subsystem Diagram made by Brandei Dieter

5.1.4 Control Subsystem 1

The Control Subsystem 1 will operate as the main control system of the robot. This will be designed and implemented by the ECE team. The ATmega2560 will communicate and power the applicable electrical components such as the Ultrasonic Sensors, the Perimeter Wire Receiver circuit, the GPS/compass module and the L293DNE motor driver chips. It will be powered by the Electrical Component's battery through the LM2596 Voltage Regulator.

5.1.5 Control Subsystem 2

The Control Subsystem 2 will operate as the main system for wireless communications and the camera. This will be designed and implemented by the ECE and Computer Science team. It will process all the computer vision, image processing, path planning and map building. It will also communicate with the Laptop application and the ATmega2560. The wireless communication will send data to the laptop application for the battery charge percentage, the math model and location. The wireless communication will receive the operation of the kill switch from the laptop application and send it to the ATmega2560. The design of the camera is shown below in Figure 40.

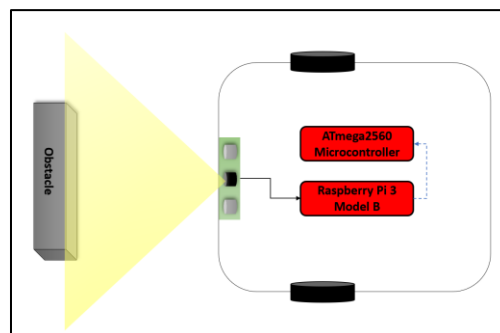

Figure 40: Control Subsystem 2 Camera Diagram made by Brandei Dieter

5.1.6 Sensors Subsystem 2

The Sensors Subsystem 2 will include the battery charge sensor. This will be designed and implemented by the ECE team. It will operate by monitoring the motor’s battery charge percent and send the data to the Raspberry Pi to the wireless chip to the laptop application. The laptop application will always show the battery charge percent of the motor’s battery. This diagram is shown below in Figure 41.

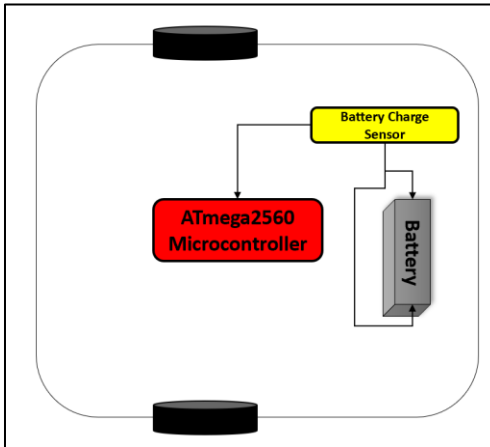

Figure 41: Battery Charge Sensor Diagram made by Brandei Dieter

5.1.7 Power Subsystem 1

The Power Subsystem 1 will be the system of the power to the motors. This will be designed and implemented by the ECE team. This battery will power the L293DNE motor drivers with 12-Volts. The motors will be powered through the L293DNE motor drivers to the six DC motors. Two DC motors will be used for the front wheels and three DC motors will be used for the blades. The motors power specifications table is shown below in Table 50.

Table 50: Motors Power Specifications Table

DC Motor Type	Quantity	Current (A)	Operating Voltage (V)	Torque (Nm)	Power (W)
Wheel Motors	2	6	12	2.6477955	72
Blade Motors	3	16.67	12	0.5099458	600
Total Maximum Power					672

5.1.8 Power Subsystem 2

The Power Subsystem 2 will be the system of the power to the electrical components. This will be designed and implemented by the ECE team. The reason to have a separate battery

for the electrical components is to limit the noise produced from the battery to the DC motors. If the electrical components and DC motors were powered by the same battery, there would be a lot of interference with the sensitive components, such as the sensors and inductors, on this system. This power system will include a voltage regulator to regulate the unregulated DC Input of 12 Volts to the regulated output of 5 Volts to the electrical components. This voltage regulator was simulated using TI Webench power design. The electrical components were adjusted to ensure the use of surface mount components. It has an efficiency of 89.6%, a bill of materials of \$4.94, and a footprint of 1201 mm². The circuit simulated is shown below in Figure 42.

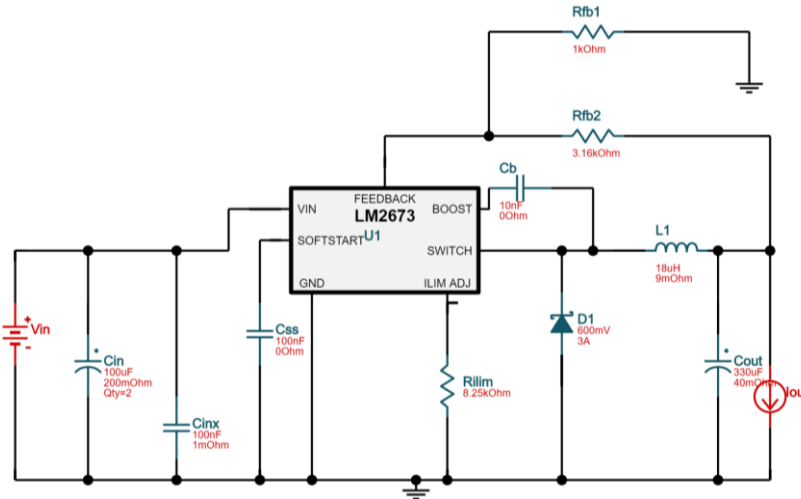

Figure 42: LM2673 Circuit Design from TI Webench Power Design Simulator

The efficiency peaks at about 93.5%. As the output current increases from one to three amperes, the efficiency rises then drops suddenly. The comparison plot between efficiency and output current at the voltages of 11 to 13 volts, is shown below in Figure 43.

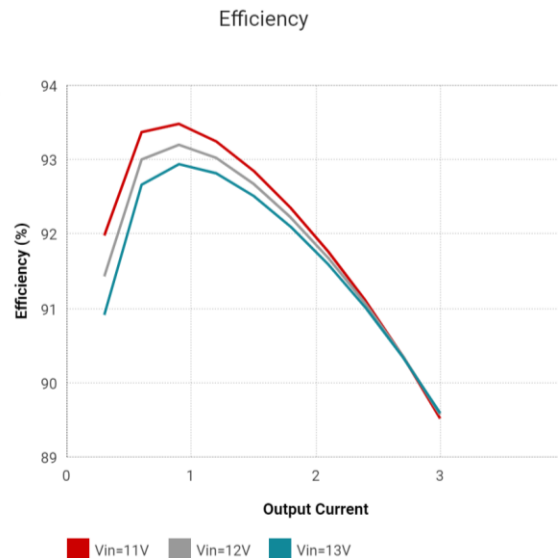

Figure 43: Efficiency Versus Output Current Plot from TI Webench Power Design Simulator

This plot shows the output current and output voltage waveforms over time. The load transient plot is shown below in Figure 44.

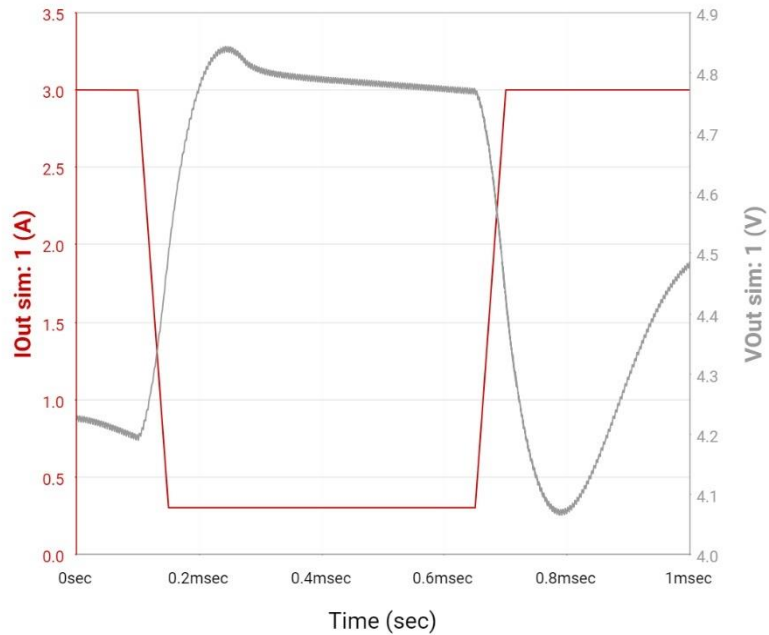

Figure 44: Load Transient Plot from TI Webench Power Design Simulator

The bode plot shows the magnitude and phase responses of the simulated voltage regulator circuit. The bode plot is shown below in Figure 45.

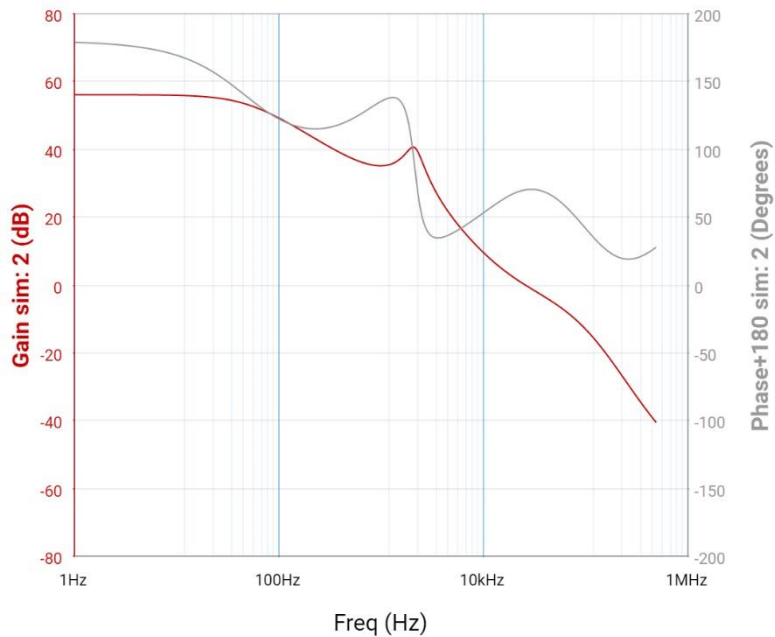

Figure 45: Bode Plot from TI Webench Power Design Simulator

5.1.9 Boundary Subsystem 1

The Boundary Subsystem 1 will include the Perimeter Wire Receiver circuit. This will be designed and implemented by the ECE team. Once the square wave signal is detected from the Perimeter Wire Generator Circuit, it will output an interrupt to the ATmega2560 microcontroller to do the proper operations. This subsystem will help guide the grass cutter robot along the boundary wire and cut as close to the boundary as possible. The Perimeter Wire Receiver circuit will have the LM324N that will amplify the signal detected from the Perimeter Wire Generator Circuit. The signal will be detected by two inductors on each side of the robot.

5.1.10 Drive Subsystem

The Drive Subsystem will be the system of the grass cutter’s movement. This will be designed and implemented by the ECE team. One Motor will be allocated to the front left wheel, front right wheel, right string-based blade, middle string-based blade and left string-based blade. Both the front wheel motors are connected to one motor driver chip. The left and right string-based blade will be connected to one motor driver chip and the middle string-based blade will be connected to one motor driver chip. The motor driver chips will be programmed to control the motor functionality, speed and direction. To turn right, more power will be allocated to the right rear wheel. To turn left, more power will be allocated to the left rear wheel. When the kill switch signal is sent, all the motors will be instructed to turn off. When an obstacle is detected, the motors will operate to turn the wheels according to the decision that is made by the Ultrasonic Sensors and the camera for the new cutting path. The drive subsystem flowchart is shown below in Figure 46 to show the functions of the drive subsystem.

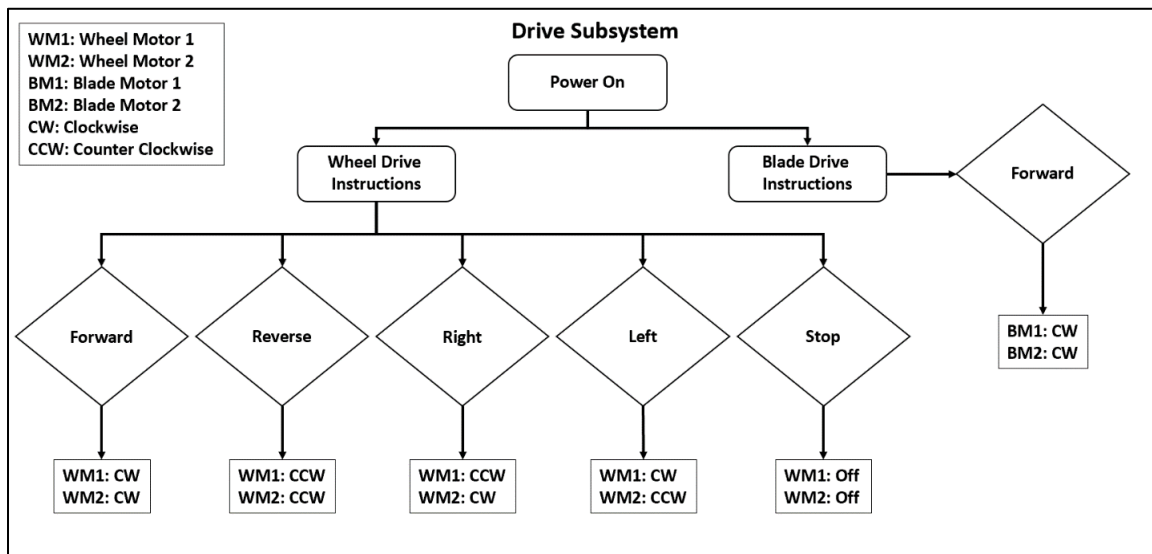

Figure 46: Drive Subsystem Flowchart made by Brandei Dieter

The drive subsystem of the grass cutter will include 5 DC motors and 3 motor drivers. They will be powered by the ATmega2560 and the 12-Volt Motor's battery. Figure 47 below shows a diagram of the drive subsystem on the grass cutter.

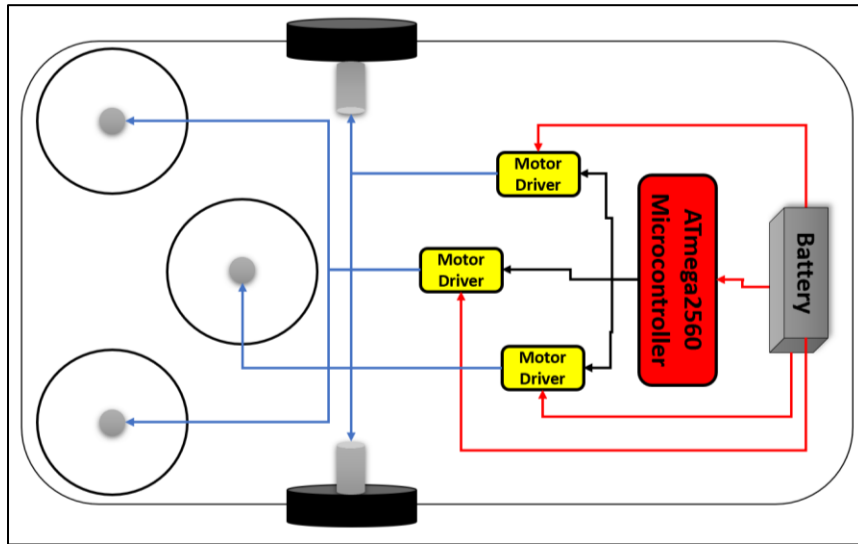

Figure 47: Drive Subsystem Diagram made by Brandei Dieter

5.1.11 Wireless Communications Subsystem

The Wireless Communications Subsystem will be the system that communicates from the ATmega2560 to the Raspberry Pi 3 Model B to the Laptop Application. This will be designed and implemented by the ECE and Computer Science Team. This will communicate through a wireless chip to transmit and receive information. The information that will be sent through the wireless communications system will be the remote kill switch instruction, location, and battery charge percent data. The diagram of the wireless communications system is shown below in Figure 48.

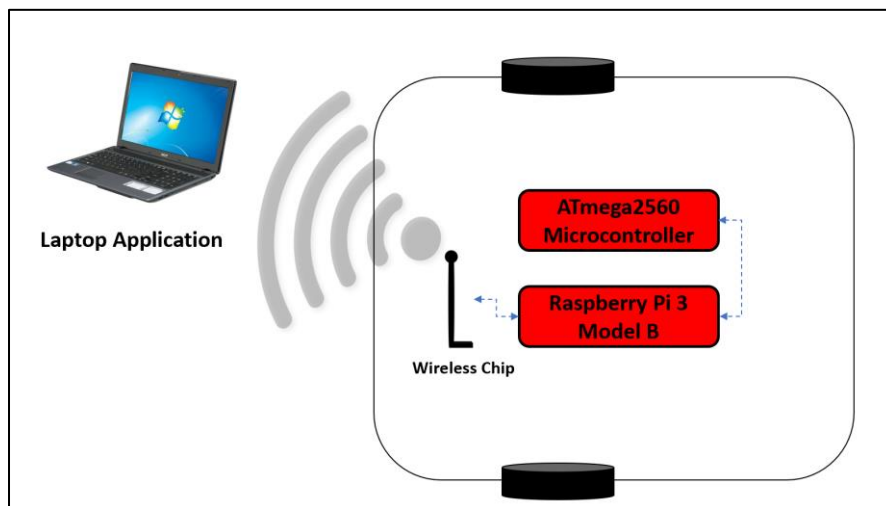

Figure 48: Wireless Communications Diagram made by Brandei Dieter

5.1.12 Laptop Application Subsystem

The Laptop Application Subsystem will be the system that will communicate with the Raspberry Pi. This will be designed and implemented by the Computer Science Team. This application will include a remote kill switch that will be capable of turning the cutting system and locomotion off at approximately 50 feet. It will also include a math model that will estimate how much grass area the robot can cut per hour for analysis. The application will show the main battery's charge percent to show a real-time charge percent on the battery. The application will be capable of showing the location of the grass cutter even after the main batteries die so someone can go find the grass cutter to charge the batteries.

5.1.13 Camera Subsystem

The Camera Subsystem will include the Night Vision Camera. This system will be designed, implemented and tested by the Computer Science team. The camera will be used in conjunction with the Raspberry Pi Board for computer vision, map building, image processing and path planning.

5.1.14 Boundary Subsystem 2

The Boundary Subsystem 2 will include the Perimeter Wire Generator Circuit. This system will be designed, implemented and tested by the ECE team. This system is crucial for the grass cutter to stay inside the set boundaries to cut the grass in. The perimeter wire generator circuit will output a square wave signal that the receiver circuit on the grass cutter will receive. This subsystem is vital for the operation of the boundary system to function properly. The perimeter wire generator circuit will have the NE555 Timer as the main component to generate the square wave output. There will be a 12 Volt Lithium Polymer battery powering this circuit.

5.1.15 Power Subsystem 3

The Power Subsystem 3 will be the system of the power to the Perimeter Wire Generator Circuit. This system will be designed, implemented and tested by the ECE team. This battery will only power the perimeter boundary circuit and perimeter boundary wire. It is crucial for the boundary system to function properly. The Perimeter wire specifications is shown below in Table 51.

Table 51: Perimeter Wire Specifications Table

Electrical Component	Quantity	Current (A)	Operating Voltage (V)	Power (W)
NE555 Timer	1	0.2	12	2.4
Total Maximum Power				2.4

5.2 Project Software Design Details

The software design refers to the overall programming of the Printed Circuit Board. This will control the whole system using ultra sonic sensors and Computer Vision (CV). The program will be capable of taking all the inputs from different devices, make decisions and appropriate outputs to the motors. The ATmega2560 will handle the program control flow to give the robot driving instructions. This machine will also have various other features including a magnetic compass, a boundary circuit, and a wireless application to activate a kill switch. All the previously mentioned features will be interfaced through software implementation. some important challenges to solve in this project are planning a path, as well as mapping locations that have already been visited. Since the robot will rely only on the ultrasonic sensors, and camera to plan and track its motion, there will be much emphasis on using computer vision to generating accurate results when navigating. The following image, in Figure 49, will illustrate how the microcontroller will interact with each system.

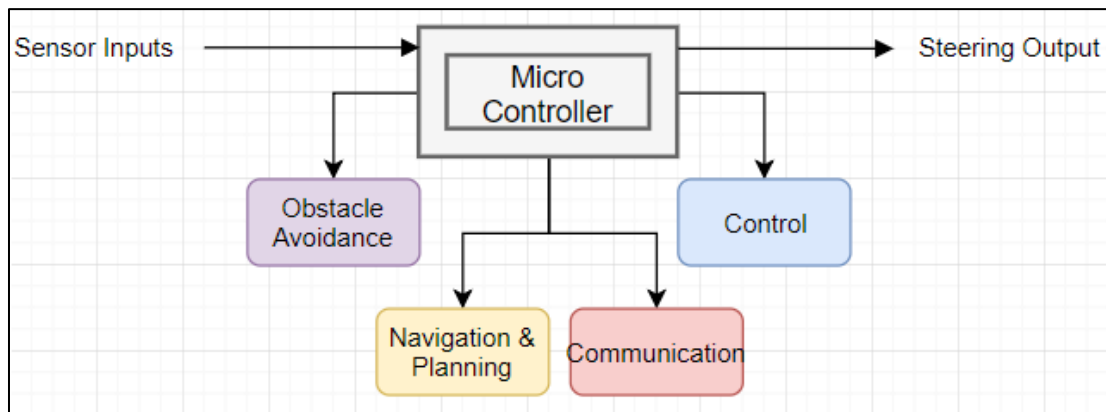

Figure 49: Subsystem Features and Software Design Space made by Mario McClelland

5.2.1 Overall Software Functionality

Using multiple sensors, there will be many signals incoming to give the robot the data needed to process that will make its drive decision. Ideally, the robot should be left anywhere within its legal perimeter and successfully navigate and cut any new area it traverses through. Initially, the robot will measure the initial position and drive forward until it meets the boundary. This can be realized through a function that will be called findBoundary(). For any new bounded area, the robot will cut, it will traverse around the boundary first, to assist in creating an appropriate map for the area to be cut. Once the robot encounters the boundary wire, it will rotate to align itself parallel to the boundary wire and drive until it completes a full circuit around the area being cut. The following diagram will illustrate the startup routine that will take place when mapping the boundaries of the field being cut. The initial startup flow chart is shown below in Figure 50.

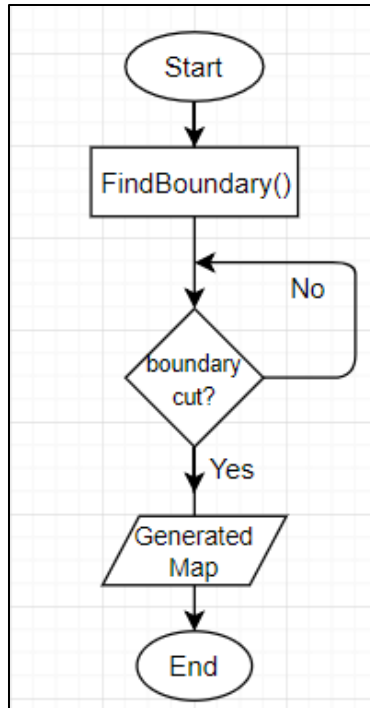

Figure 50: Initial Start Up flow chart made by Mario Mcclelland

5.2.1.1 Ultrasonic Sensor and Obstacle Avoidance

In conjunction with a camera, the ultrasonic sensor will be programmed to measure the distance between the objects that the computer vision encounters. To save power, the sensor will only be given power when it is needed. Since the start up times are generally very low for this kind of device, it will be helpful when considering longevity. Some of the code for this is shown in Figure 51.

```

while(Obstacle Detected)
{
    turnSensorOn();
    d = measureDistance();
    turnSensorOff();
}

return d;
  
```

Figure 51: Sample Code for Sensors made by Mario Mcclelland

Once the value of *d* in the code above is at an acceptable value, it will engage the robot to avoid the obstacle by turning it until the sensor is turned off again. Once the sensor is turned off, the robot will then rely on computer vision to navigate parallel to the obstacle that is encountered and trim the edges of the obstacle. In some cases, the obstacle might be ignored given the intelligence of the result. The following image shows a diagram relating how the system will interact with the microcontroller and the real world as a closed looped system. The diagram of how the microcontroller and ultrasonic sensor will communicate is shown in Figure 52 below.

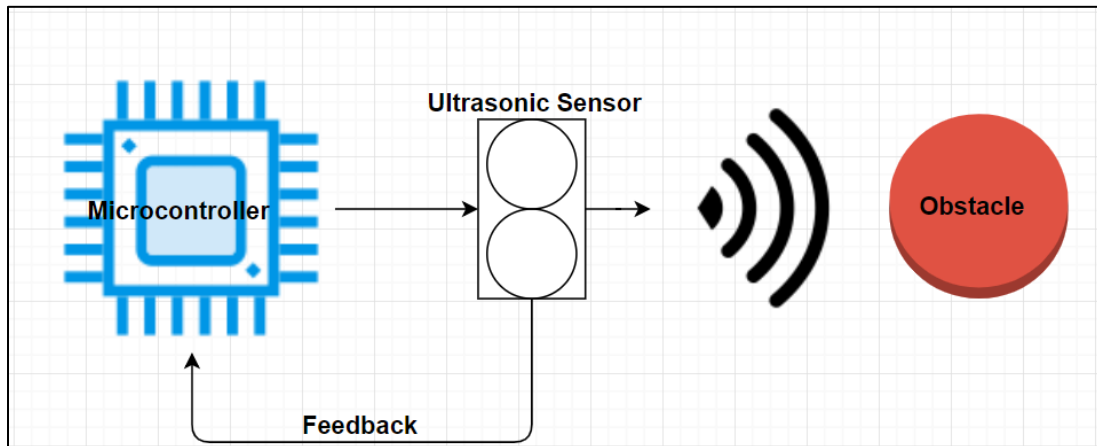

Figure 52: Microcontroller to Ultrasonic Sensor Communications Diagram made by Mario Mccllelland

5.2.1.2 Camera and Obstacle Detection

For this project, the camera will be programmed by the computer science team. The relevance of using computer vision is to steer clear of obstacles, as well as make sure there is a clean cut around them. Ideally, any obstacle that is encountered at less than 5 inches, will generate an interrupt service routine, that will give the robot instructions rotate it appropriately and cut along the edges of the object that is encountered. This approach will be like the approach taken to map the area of the land, in which the robot will attempt to move in a direction parallel to the object that is encountered. The diagram of how the microcontroller and the camera will communicate is shown in Figure 53 below.

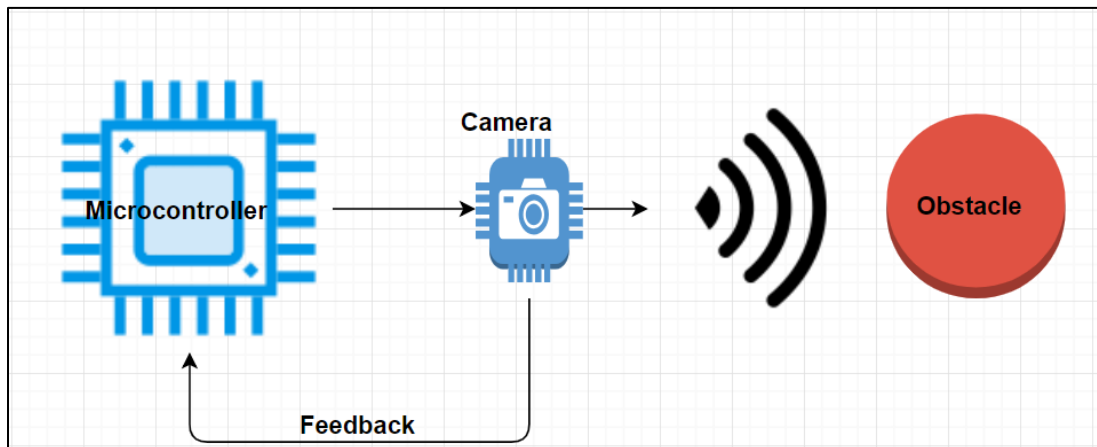

Figure 53: Microcontroller to Camera Communications Diagram made by Mario Mccllelland

The camera software flowchart will describe its decision making in the algorithm for the grass cutter system. The camera will check if the environment has been mapped or not. If it has been, it will then path plan. When an object is in its path, it will make a path decision and repeat this loop forever. These algorithms will be done on the Raspberry Pi 3 Model B. The camera software flowchart is shown below in Figure 54.

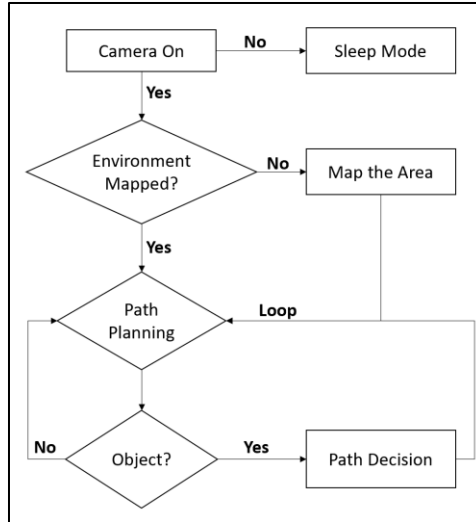

Figure 54: Camera Software Flowchart made by Mario Mcclelland

5.2.1.3 Perimeter Wire System Software Design

One of the critical aspects of this project require a mechanism that will not allow the robot to leave the area that it is designated to cut. For this project, the solution that has been made is a boundary wire that will set the legal perimeter of the robot. When the signal is received that the robot has encountered the boundary wire, it will either cut around the boundary of the lawn to be cut or avoid it completely by making turning around and cutting new grass orthogonal to the boundary wire. Upon reaching the boundary, a circuit that will be configured into the robot will send a signal to the microcontroller that will give instructions to handle this. The strength of the signal can be changed to increase or decrease the distance travelled between the robot and the boundary wire. Another important aspect of this design feature is that the robot will always seek the perimeter of the area out to the boundary wire and cut around the boundary to create a map according to the boundary that will enclose the field.

The perimeter wire system software will implement an analog read algorithm. The pins from the perimeter wire receiver circuit will output as an input to two analog pins on the ATmega2560. The two inductors will receive the signal from the perimeter wire and the values will be reported to the ATmega2560. The values shown are a ratio of the input voltage and integer that results in voltage per unit. Some of the code for this is shown below in Figure 55.

```

void loop()
{
  value1 = analogRead(analogPin1); // Read the analog input pin 1
  value2 = analogRead(analogPin2); // Read the analog input pin 2
  Serial.println("Inductor 1:"); // Inductor 1 Values
  Serial.println(value1); // Debug Value1
  Serial.println("Inductor 2:"); // Inductor 2 Values
  Serial.println(value2); // Debug Value2
}
  
```

Figure 55: Sample Code for Perimeter Wire System made by Mario Mcclelland

5.2.1.4 GPS Module with Compass

Using a combination of the boundary wire implementation, sensors, camera as well as the GPS module that will control much of the locomotion for the system. It will calculate its positioning, and we can visualize the visited points using a free tool that can be found online. This visualization will also set hard boundaries for the system when mapping when travelling the boundary of the field to be cut. We can use the Raspberry Pi to communicate through Wi-Fi and will store this information to also keep track of the grassy areas that have been already visited.

The compass that is also integrated with the GPS module is capable of measuring rotations about the central axis of the robot. This will accurately turn the system at small increments of angles and use the computer vision for any threshold that will allow us to steer in a wide variety of directions instead of the traditional left, right, reverse. This module is also capable of showing the exact location, position and speed of the robot. Some of the sample code for the GPS module is shown below in Figure 56.

```
void loop()
{
  while(serial_connection.available()) //While there are characters to come from the GPS
  {
    gps.encode(serial_connection.read()); //This feeds the serial NMEA data into the library one char at a time
  }
  if(gps.location.isUpdated()) //Constantly updating but will reduce updates only after a package of NMEA data comes in
  {
    //Get most recent data from the GPS object which it derived from the data sent by the GPS unit
    Serial.println("Satellite Count:");
    Serial.println(gps.satellites.value());
    Serial.println("Latitude:");
    Serial.println(gps.location.lat(), 6);
    Serial.println("Longitude:");
    Serial.println(gps.location.lng(), 6);
    Serial.println("Speed MPH:");
    Serial.println(gps.speed.mph());
  }
}
```

Figure 56: Sample Code for GPS Module made by Mario Mcclelland

5.2.1.5 Motor Control System

The system will drive itself using the motors that will be equipped with motor driver chips. The motor driver chips will receive a calculated input from the microcontroller. The combination of sensors used will define the locomotion of the robot and its behavior. By evaluating the data received from the obstacle avoidance and obstacle detection sub system the motor driver chips will receive an operation from the microcontroller to send out the proper voltages, speed and power specifications to the DC motors. The motor driver chips controlling the two front wheels will be programmed in such a way that the operations sent from the microcontroller will turn the motors clockwise, counter-clockwise, faster or slower. The motor driver chips controlling the three blades will be programmed in such a way that the operations from the microcontroller will turn the motors clockwise or counter-clockwise. The motor driver chips will also be responsible for relaying the signal from the microcontroller to turn the motors on and off.

6.0 Project Testing and Prototype Design

The prototype design will be used to test a model of the system for functionality. The software and hardware of the grass cutter system will be tested. Some of the select parts for this project have not yet been ordered or received. Those parts are scheduled to order/be received in Senior Design II in Spring 2019 due to the shipping time and ordering process from overseas. This will include the String-Based Blade DC motors, Motor's 12-Volt battery, Electrical Component's 12-Volt battery and the perimeter 12-Volt wire's battery. The parts that have been ordered and received so far for testing are shown below in Table 52.

Table 52: Parts Ordered and Received for Testing

Item	Place of Order	Application
NE555 Timer	Robotshop.com	Used for generating square wave signal through the perimeter wire
Resistors	Robotshop.com	Used for overall PCB designs for electrical components
Capacitor	Robotshop.com	Used for overall PCB designs for electrical components
Inductors	Robotshop.com	Used for boundary receiver circuit
20 AWG Perimeter Wire	Robotshop.com	Used for Perimeter Wire
Power Jack	Robotshop.com	Used for boundary generator circuit
Male Headers	Digikey.com	Used as connectors to PCB
Female Headers	Digikey.com	Used as connectors to PCB
2 Pin Screw Terminals	Digikey.com	Used as connectors to PCB
Jumper Wires	Amazon.com	Used to connect pins of electrical components to PCB
LM324N	Robotshop.com	Operational Amplifier used for boundary receiver circuit
Raspberry Pi 3 Model B	Amazon.com	Used for running Computer Vision and image processing algorithms and wireless communications
Night Vision Camera	Amazon.com	Used to aide in computer vision and image processing
HC-SR04 Ultrasonic Sensors	Amazon.com	Used for obstacle detection and avoidance
LM2596 Motor Driver	Digikey.com	Used for DC motor control
Holybro GPS Module	Amazon.com	Used for location and positioning
Arduino MEGA	Amazon.com	Used for overall PCB control of all the electrical components
Battery Charge Sensor	Robotshop.com	Used for motor battery
Breadboard	Amazon.com	Used for testing

6.1.1 Prototype Design

The Schematic and Printed Circuit Board will be designed on EasyEDA.com. The use of surface mount components will be implemented for the resistors, capacitors, microcontroller and integrated circuits that are applicable to the designs. Some electrical components are not available as surface mount for this design.

6.1.1.1 Grass Cutter System Circuit Schematic

This schematic was design on EasyEDA.com. This includes the main components that will be connected to the custom-made Printed Circuit Board for the Grass Cutter System. This will include the overall control, locomotion, voltage regulators, motors battery connections, electrical components battery connections, GPS module, Ultrasonic Sensors, interface with the Raspberry Pi and the motor drivers. The Grass Cutter System Circuit Schematic design is shown below in Figure 57.

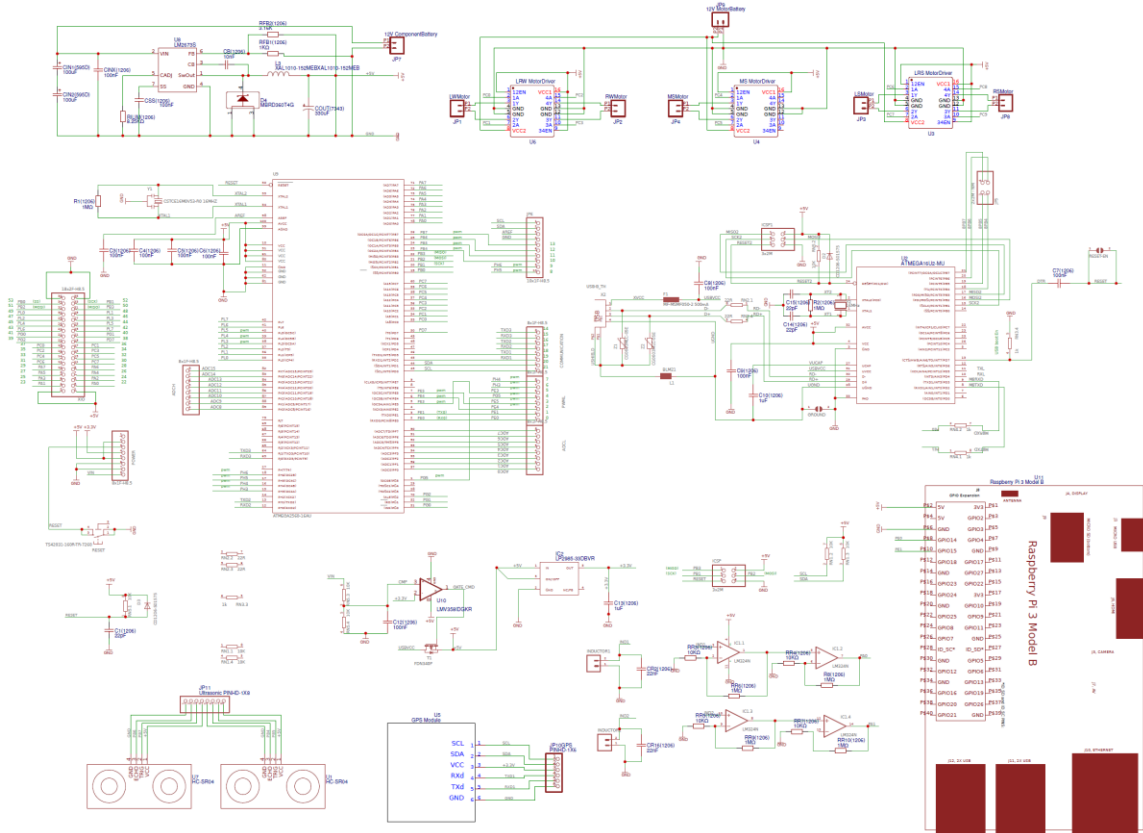

Figure 57: Grass Cutter System Circuit Schematic made by Brandei Dieter

The PCB design of the grass cutter system circuit schematic has not been completed with this design. The PCB design is constructed just not organized.

6.1.1.2 Perimeter Wire Generator Circuit Schematic

The Perimeter Wire Generator Schematic design is shown below in Figure 58.

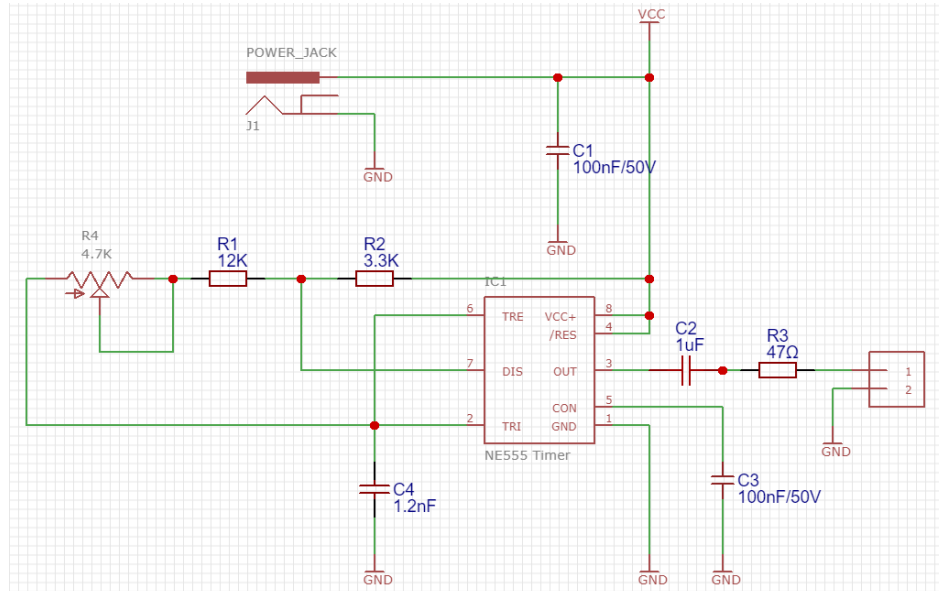

Figure 58: Perimeter Wire Generator Circuit Schematic made by Brandei Dieter

6.1.1.3 Perimeter Wire Generator Circuit PCB

The Perimeter Wire Generator circuit PCB design is shown below in Figure 59.

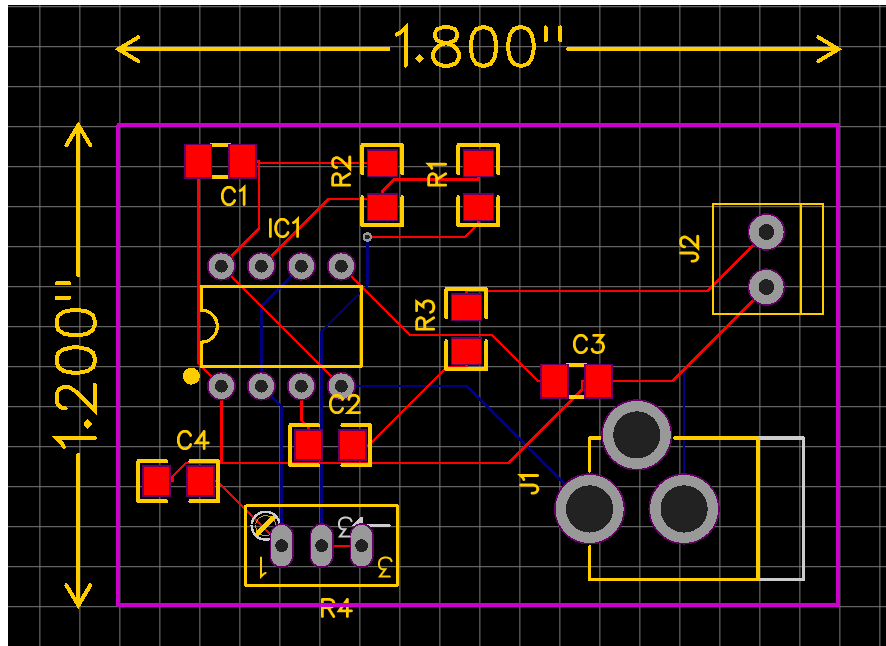

Figure 59: Perimeter Wire Generator Circuit PCB made by Brandei Dieter

6.3 Testing

Testing of the electrical components will ensure the correct power specifications, accuracy, efficiency and functionalities of all the components that will be used in this project. Table 53 below shows the overall testing results.

Table 53: Overall Testing Results

Technology Tested	Equipment Used	Results
Motor Control	-LM2596 Motor Driver Chip -DC Gear Motors -Arduino Mega -Jumper Wires	-Verified speed control -Verified bi-directional control -Verified ability to control two DC motors independently -Verified software algorithms using the Arduino Mega and the LM2596 Motor Driver Chips
Ultrasonic	-HC-SR04 Ultrasonic Sensors -Arduino Mega -Jumper Wires	-Verified accuracy of measuring distance from an object -Verified the detection of objects -Verified software algorithms using the Arduino Mega and the HC-SR04 Ultrasonic Sensors
Perimeter Boundary System	-NE555 Timer -Resistors -Capacitors -Inductors -LM324N Op-Amp -Jumper Wires	-Verified the functionality of the perimeter boundary system -Verified the accuracy of receiver circuit to the perimeter wire generator circuit -Verified the range of the receiver coils to the perimeter wire -Verified the software algorithms using the Arduino Mega and perimeter wire receiver and generator circuit
Camera	-Night Vision Camera -Raspberry Pi 3 Model B	-Verified the functionality of the camera using Raspbian OS -Verified image and video of the Night Vision Camera -Verified the LEDs turning on and properly functioning in a dark environment -Verified the software algorithms using the Raspberry Pi 3 and the Night Vision Camera
Location and Positioning	-Holybro GPS Module -Jumper Wires -Arduino Mega	-Verified the functionality of the GPS module -Location and positioning functions verified -Verified the software algorithms using the GPS module and the Arduino Mega

6.3.1 Motor Control Breadboard Testing

The motor testing was tested with the Arduino Mega with the ATmega2560 microcontroller, LM2596 Motor Driver Chip and DC gear motors. The use of a miniature car platform was used for prototyping before the final design is constructed. The Arduino Mega was programmed using a test code for motor control with the LM2596 Motor driver chips on the Arduino IDE. The testing of the motor control was successful. The speed, delays, and direction of the motors were successfully verified. The testing is shown below in Figure 60.

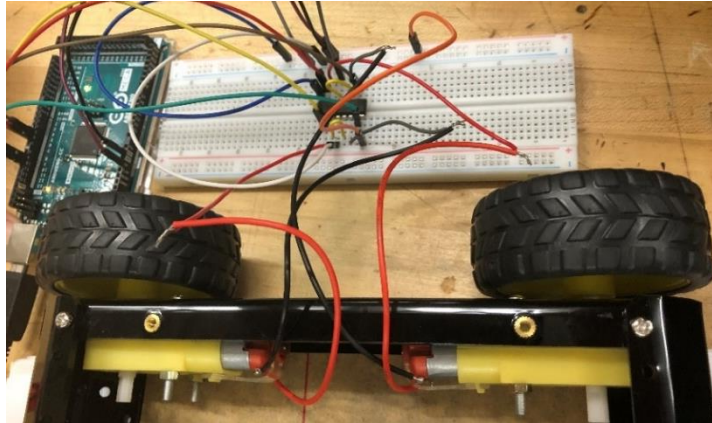

Figure 60: Motor Driver Chip and DC Motors Tested picture taken by Brandei Dieter

6.3.2 Ultrasonic Breadboard Testing

The Ultrasonic testing was tested using the Arduino Mega with the ATmega2560 microcontroller and HC-SR04 Ultrasonic Ranging Modules. The Arduino Mega was programmed using a test code for sensors with the HC-SR04 Ultrasonic Sensors on the Arduino IDE. The testing of the ultrasonic sensors was successful. The accuracy, range and function were successfully verified. The testing is shown below in Figure 61.

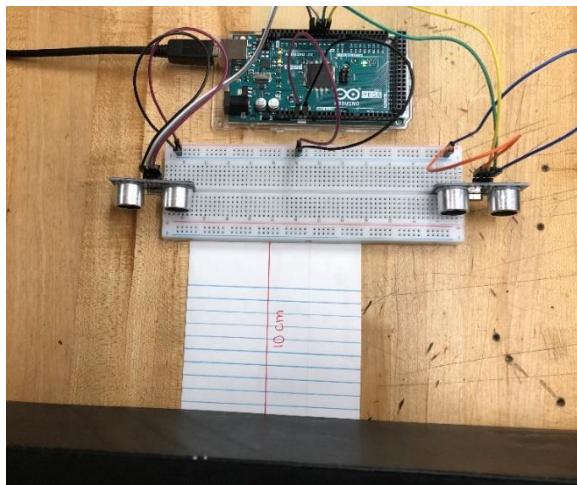

Figure 61: Ultrasonic Sensors Tested picture taken by Brandei Dieter

The measurement of the sensors to the object was measured at 10 centimeters and successfully verified through the program ran through the Arduino IDE. This is shown below in Figure 62.

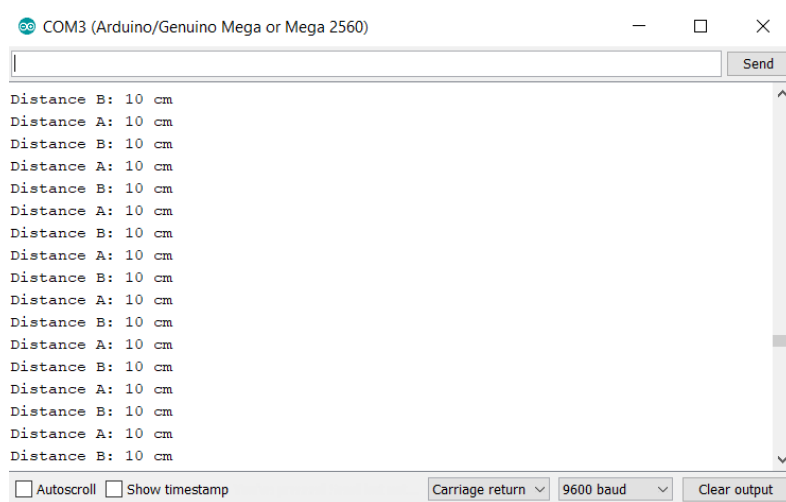

Figure 62: Ultrasonic Sensors Accuracy Tested picture taken by Brandei Dieter

6.3.3 Perimeter Boundary System Breadboard Testing

The Perimeter Boundary System testing was tested using the Arduino Mega with the ATmega2560 microcontroller, various resistors, various capacitors, LM324N Operational Amplifier, NE555 Timer, 20AWG perimeter wire, inductors, jumper wires and a variable resistor. The Arduino Mega was programmed using a test code for analog read form the analog input pins, with the perimeter boundary system on the Arduino IDE. The testing of the Perimeter Boundary System was successful. The accuracy, range and function were successfully verified. The testing is shown below in Figure 63.

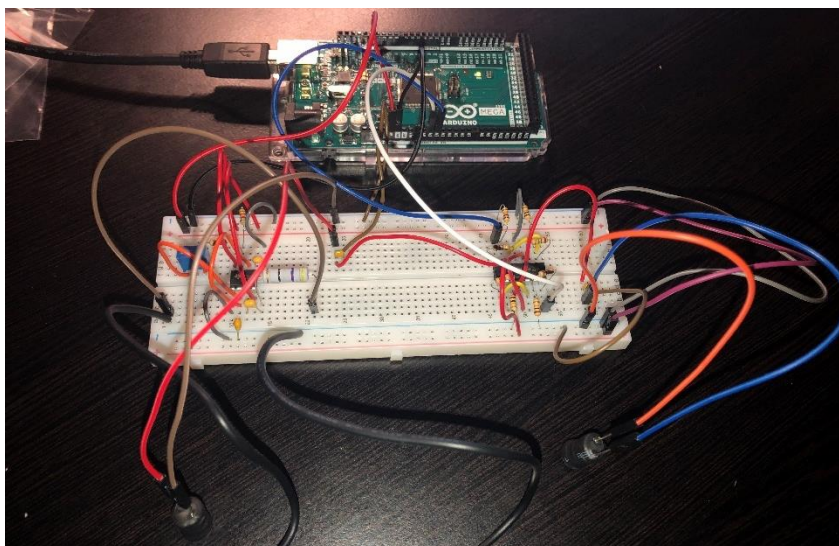

Figure 63: Perimeter Boundary System Tested picture taken by Brandei Dieter

The inductor sensors to the perimeter wire maps input voltages between 0 and 5 Volts into integer values between 0 and 1023. This value corresponds to a resolution between readings of a ratio between the input voltage and integer values resulting in how much voltage per unit. This testing was successfully verified through the program ran through the Arduino IDE. This is shown below in Figure 64.

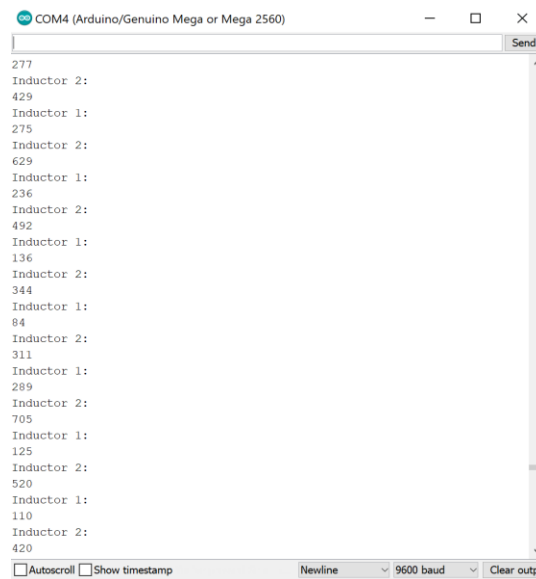

Figure 64: Perimeter Boundary System Functionality Tested picture taken by Brandei Dieter

6.3.4 Camera Raspberry Pi Testing

The camera testing was tested using the Raspberry Pi 3 Model B and the Raspberry Pi Night Vision Camera. The Raspberry Pi 3 Model B was programmed using a test code for camera imaging and video, with the night vision camera on the Raspbian Operating System. The testing of the camera was successful. The functionality of the camera was verified. The testing is shown below in Figure 65.



Figure 65: Camera Tested picture taken by Brandei Dieter

6.3.5 Location and Positioning Breadboard Testing

The GPS module testing was tested using the Arduino Mega 2560 and the Holybro Micro M8N GPS module. The Arduino Mega 2560 was programmed using a test code for GPS location and positioning with GPS module on the Arduino IDE. The testing of the GPS module was successful. The functionality of the GPS module was verified. The testing is shown below in Figure 66.

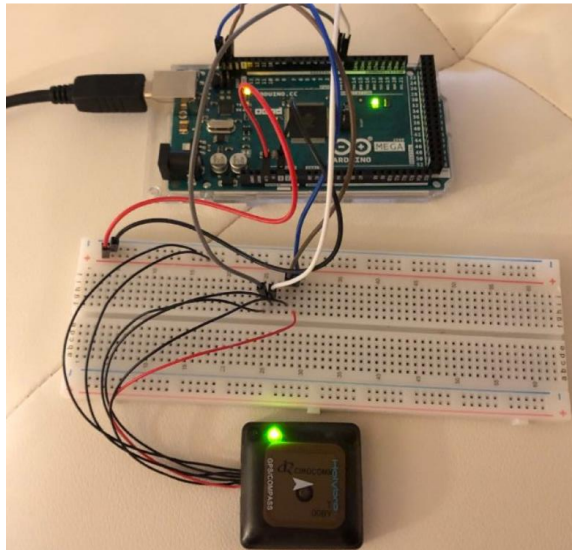

Figure 66: GPS Tested picture taken by Mario McClelland

The sequence of characters, shown below, are separated by commas which are standardized data specifications called NMEA. Each value between the comma represents a certain value which will be parsed using a library installed onto the chip. The parser will be able to identify the global positioning, as well as many other features including speed, time, date, and direction. The standard example of the GPS output is shown below in Figure 67.

```
COM3 (Arduino/Genuino Mega or Mega 2560)
$GNGSA,A,3,08,,,,,,,,,,,,,3.92,2.12,3.30^15
$GPGSV,3,1,12,03,11,214,06,07,19,307,,08,56,171,16,09,48,304,15^7C
$GPGSV,3,2,12,11,08,182,09,16,42,032,19,18,03,166,,22,04,195,^7B
$GPGSV,3,3,12,23,69,259,21,26,20,050,11,27,65,100,22,31,08,103,11^75
$GLGSV,3,1,11,66,00,179,15,67,34,218,11,68,38,288,,69,08,331,^60
$GLGSV,3,2,11,77,36,035,,78,38,327,,79,06,285,,81,04,176,^6F
$GLGSV,3,3,11,86,06,026,,87,39,076,,88,34,138,10^51
$GNGLL,2833.33896,N,08110.01182,W,014119.00,A,A^66
$GNRMC,014120.00,A,2833.33659,N,08110.01113,W,1.160,,031218,,A^7F
$GNVTG,,T,,M,1.160,N,2.149,K,A^35
$GNGGA,014120.00,2833.33659,N,08110.01113,W,1,08,1.29,23.4,M,-29.5,M,,^48
$GNGSA,A,3,23,27,08,16,26,03,11,,,,,1.81,1.29,1.26^17
$GNGSA,A,3,08,,,,,,,,,,,,,1.81,1.29,1.26^1B
$GPGSV,3,1,12,03,11,214,12,07,19,307,,08,56,171,18,09,48,304,14^76
$GPGSV,3,2,12,11,08,182,11,16,42,032,19,18,03,166,,22,04,195,^72
$GPGSV,3,3,12,23,69,259,21,26,20,050,12,27,65,100,23,31,08,103,09^7E
$GLGSV,3,1,11,66,00,179,16,67,34,218,11,68,38,288,,69,08,331,^63
$GLGSV,3,2,11,77,36,036,,78,38,327,,79,06,285,,81,04,176,^6C
$GLGSV,3,3,11,86,06,026,,87,39,076,,88,34,138,10^51
$GNGLL,2833.33659,N,08110.01113,W,014120.00,A,A^69
```

Figure 67: Standard Example GPS Output by Mario McClelland

7.0 Administrative Content

The administrative content section includes fall 2018 milestones, spring 2019 milestones, PCB vendor information and budget and financing of this project.

7.1 Fall 2018 Senior Design I Milestones

The Fall 2018 Senior Design I milestones are to keep the project and group on track and organized for the fall semester. Table 54 shown below is a detailed table showing the tasks, start and end dates, status and responsibilities of each task.

Table 54: Fall 2018 Senior Design I Milestones Table

Fall 2018- Senior Design I					
Num.	Task	Start	End	Status	Responsible
1	Group Members Established	08/22/18	08/22/18	Completed	Group 19
2	Research Project Idea	08/22/18	09/14/18	Completed	Group 19
3	Project Idea	08/22/18	08/29/18	Completed	Group 19
4	Initial Document – Divide & Conquer	09/10/18	09/14/18	Completed	Group 19
5	Prepare Questions for Meeting	09/03/18	09/14/18	Completed	Group 19
6	SD1 Half Hour Meeting	09/17/18	09/19/18	Completed	Group 19
7	Sponsor Meeting	09/20/18	09/21/18	Completed	Group 19
8	Cover Page	09/01/18	09/01/18	Completed	Group 19
9	Table of Contents	09/01/18	11/28/18	Completed	Group 19
10	Project Description	09/01/18	09/03/18	Completed	Group 19
11	Research	09/01/18	11/28/18	Completed	Group 19
12	Related Standards and Design Constraints	09/01/18	09/07/18	Completed	Group 19
13	Hardware Design	09/20/18	10/01/18	Completed	Group 19
14	Software Design	10/01/18	11/01/18	Completed	Group 19
15	Conclusion	11/15/18	11/28/18	Completed	Group 19
16	Copyright Permissions	11/15/18	11/28/18	Completed	Group 19
17	Citations	11/16/18	11/30/18	Completed	Group 19
18	Table of Figures and Table of Tables	11/16/18	11/30/18	Completed	Group 19
19	Final Document Draft	11/20/18	11/21/18	Completed	Group 19
20	SD1 Half Hour Meeting	11/23/18	11/23/18	Completed	Group 19
21	Revision of Final Document	11/30/18	11/30/18	Completed	Group 19
22	Final Document Due	12/03/18	12/03/18	Completed	Group 19
23	Order Components	09/28/18	12/01/18	Completed	Group 19
24	Build Prototype	10/15/18	11/30/18	Completed	Group 19
	Test Electrical Components	11/20/18	11/30/18	Completed	Group 19
25	Test with breadboard	11/30/18	11/30/18	Completed	Group 19

7.2 Spring 2019 Senior Design II Milestones

The Spring 2019 Senior Design II milestones are to project the future goals in the spring to keep the project and group on track and organized. Table 55 shown below is a detailed table showing the tasks, start and end dates, status and responsibilities of each task.

Table 55: Spring 2019 Senior Design II Milestones Table

Spring 2019- Senior Design II					
Num.	Task	Start	End	Status	Responsible
1	Electrical Components Ordered	11/20/18	01/10/19	Pending	Group 19
2	Batteries Ordered	12/03/18	01/10/19	Pending	Group 19
3	Verify committee members	01/01/19	01/20/19	Pending	Group 19 and committee members
4	Schematic Design Finalized	01/01/19	01/20/19	Pending	Group 19
5	PCB Design Finalized	01/01/19	01/25/19	Pending	Group 19
6	Group Meeting	01/20/19	TBD	Pending	Group 19
7	Prototype Equipment Bought	01/22/19	1/22/19	Pending	Group 19
8	PCB Board schematic for prototype trial #1	01/30/19	02/03/19	Pending	Group 19
9	Ordered trial #1 PCB Board from JLCPCB	02/03/19	02/04/19	Pending	Group 19
10	Initial Wheel Motors in Operation	02/10/19	02/09/19	Pending	Group 19
11	Initial Blade Motors in Operation	02/10/19	02/09/19	Pending	Group 19
12	Sensor on Microcontroller initiated	02/20/19	02/22/19	Pending	Group 19
13	Operation of wheels and Sensors for Trial #1 prototype complete	02/28/19	02/28/19	Pending	Group 19
14	Group Meeting in regard to Trial #1	03/01/19	03/01/19	Pending	Group 19
15	Improve Prototype	03/02/19	03/10/19	Pending	Group 19
16	Test Prototype Trial #2	03/11/19	03/11/19	Pending	Group 19
17	Group Meeting in regard to Trial # 2	03/12/19	03/12/19	Pending	Group 19
18	Improve Prototype	03/13/19	03/14/19	Pending	Group 19
19	Group Meeting in regard to Trial #3	03/15/19	03/15/19	Pending	Group 19
20	Finalize Prototype (Final Trial #3)	03/15/19	04/01/19	Pending	Group 19
21	Finished Product	04/10/19	04/20/19	Pending	Group 19
22	Peer Report	TBD	TBD	Pending	Group 19
23	Final Documentation	01/01/19	05/03/19	Pending	Group 19
24	Final Presentation	TBD	TBD	Pending	Group 19 and committee members

7.2 PCB Vendor [96]

After careful consideration and research, the PCB Vendor being used is JLCPCB. It will be convenient and cost efficient to order from directly from EasyEDA.com where the schematic and PCB will be designed. “JLCPCB is the largest PCB prototype enterprise in China and a professional PCB manufacturer featured of large scale, well equipment, strict management and superior quality [96]”.

The prices for producing PCBs from JLCPCB are shown below in Table 56.

Table 56: Prices and Specifications of PCBs from JLCPCB.com [96]

Layers	2	4	6
Size	≤ 100x100mm	≤ 100x100mm	≤ 100x100mm
Material	FR4	FR4	FR4
Thickness	1.6mm	1.6mm	1.6mm
Weight	1oz	1oz	1oz
Plate Finish	HASL	HASL	HASL
Color	Green Solder Mask White Silkscreen	Green Solder Mask White Silkscreen	Green Solder Mask White Silkscreen
Quantity	10 pcs	10 pcs	10 pcs
Delivery Time	2-3 days	4-5 days	6-7 days
Cost of PCBs	\$2.00	\$15.00	\$80.00

The shipping details are shown below in Table 57. Shipping is done through DHL Express or Standard Registered Air Mail.

Table 57: Shipping Details from JLCPCB.com [97]

	DHL	Registered Air Mail
Delivery Option	Express	Standard
Expected Delivery Time	3-4 days	15-30 days
Package Weight	0.16 kg	0.16kg
Delivery Cost	\$18.50	\$9.92

The assembly of the Printed Circuit Boards (PCBs) will require soldering of components and wires to the board. There will be two designed PCBs, one for the overall grass cutter system and one for the perimeter wire boundary generator system. The PCBs will be designed in EasyEDA.com. The designed PCB will be labeled for where each component or device will be placed. There will be two designs that will be designed, implemented and ordered from JLCPCB. This includes the perimeter generator circuit and the overall system circuit. There are a variety of capabilities available for the Printed Circuit Board. The different capabilities are as shown below in Table 58.

Table 58: PCB Capabilities from JLCPCB.com [98]

Layers	1-6 layers PCB prototypes Available
Material	FR-4 Board Material
Max Dimensions	400x500mm
Dimension Tolerance	±0.2mm for CNC routing and ±0.2mm for V-scoring
Solder Mask	Liquid Photo-Imageable Solder Mask
Thickness	0.4-2.0mm
Thickness Tolerance	±10% for T ≥1.00mm and ±0.1mm for T < 1.0mm
Finished Outer Layer Copper	1oz/2oz
Finished Inner Layer Copper	0.5oz
Minimum Trace	5mil for Single- and Double-Layer PCBs, 3.5mil for Multi-Layer PCBs
Minimum Spacing	5mil for Single- and Double-Layer PCBs, 3.5mil for Multi-Layer PCBs
Minimum Via Hole Size	0.3mm for Single- and Double-Layer PCBs, 0.2mm for Multi-Layer PCBs
Minimum Via Diameter	0.6mm for Single- and Double-Layer PCBs, 0.45mm for Multi-Layer PCBs
Via to Trace	Minimum distance between via (plated holes) and trace is 5mil
Drill Hole Size	0.2-6.3mm
Hole Size Tolerance	±0.08mm
Annular Ring	≥ 3mil
Minimum Character Width	≥ 6mil
Minimum Character Height	≥ 32mil
Trace to Outline	≥ 0.2mm
Panelization Without Space	0mm
Panelization With Space	≥ 2mm
Minimum Edge Rails	3mm
Copper Hatching with Pads	Cooper Hatching will be applied if the PCBs designed with Pads
Slot Drawing with Pads	Outline must be used to design if there are many non-played (NPTH) holes
Protel/dxp Solder Layer	Solder Layer and Paste Layer are not the same
Protel/dxp Outline Layer	Pick Keep out Layer or Mechanical Layer as outline
Minimum Half Hole Diameter	0.6mm

7.3 Budget and Financing

These are the parts that have been selected that are applicable to add to this table for Senior Design I. This table is subject to change as the project progresses into Senior Design II. The project budget and financing table is shown below in Table 59.

Table 59: Project Budget and Financing Table 1

Item	Description	Qty.	Cost
Development Board	1xRaspberry Pi 3 Model B	1	35.00
Microcontroller	1xATmega2560	1	12.00
Development Board	1xArduino Mega	1	38.50
Microcontroller	1xATmega16U2	1	2.53
Perimeter Wire	1xAutomower Boundary Wire	1	59.00
Cable	1x20AWG 1M cable	1	1.00
Screw Terminals	10xED10561-ND, 125V, 6A, 1x02 2.54mm	3	10.00
NE555P Timer	1xNE555P Timer	1	0.95
Power Jack	1xEJ503A Power Jack	1	1.00
LM324N	1xLM324N	1	0.52
Resistors Kit	1206 Package	1	2.00
Variable Resistor	1xS64W Variable resistor 4.7k Ω , 3296W	1	1.00
Capacitors Kit	1206 Package	1	2.00
Inductors	2xRLB0914 Inductors 1mH, 420mA	2	2.00
Inductor Wires	Adjustable size Wires	2	1.00
Night Vision Camera	1xRaspberry Pi 3 Model B Night Vision Camera	1	25.99
Ultrasonic Sensor	2xHC-SR04 Ultrasonic Sensor	2	5.00
Battery Charge Sensor	1xLiPo Fuel Gauge Battery Charge Monitor	1	9.95
GPS Module	1xHolybro Micro M8N GPS Module	1	36.99
Pin Header	1x08 Pin Header for Ultrasonic Sensors	1	0.25
Pin Header	1x06 Pin Header for GPS Module	1	0.25
USB Wi-Fi Module	1xUSB Wi-Fi (802.11b/g/n) Module with Antenna	1	19.95
Motor Driver Chip	3xL293DNE Motor Driver Chip	3	10.00
Wheel Motors	2xDC 12V/180RPM Geared Motor	2	25.00
String-Based Blade Motors	3xMachifit 895 DC Gear Motor	3	48.00
Step-Down Voltage Regulator	1xLM2673S-ADJ 3-A Step-Down Voltage Regulator with Adjustable Current Limit	1	4.86
LDO Voltage Regulator	1xLP2985-33 Low Drop Out Voltage Regulator	1	3.00
LMV358 Operational Amplifier	1xLMV358 Low-Voltage Rail-to-Rail Output Operational Amplifier	1	2.00

The project budget and financing table continues below in Table 60.

Table 60: Project Budget and Financing Table2

Item	Description	Qty.	Cost
Chip Resistor Array	2x1k Ω (CAY16), 2x10k Ω (CAT16), 1x22 Ω (CAY16)	1	5.00
Diode	1xMBRD360T4G T0-252-2 Schottky Diode	1	1.00
Inductors	1xXAL1010-152MEB Fixed Inductor 1.5 μ H	1	1.00
MOSFET	1xFDN340P Single P-Channel, Logic Level, Power Trench MOSFET	1	2.00
Battery Wires	6xBattery Wires to the battery terminals	6	6.00
Motors Battery	1xDMD 100Ah/12V Li-Ion Battery	1	169.00
Electrical Components Battery	1xYinkai Power 20Ah/12V Li-Ion Battery	1	50.00
Perimeter Wire Battery	1xGreatMax 10Ah/12V Li-Po Battery	1	13.00
String-Based Trimmer Head	Pivotrim Pro String Trimmer	1	10.99
String-Based Blade	Nylon String-Based Blade	1	10.00
Shaft Adapters	0.5-inch shaft	1	5.00
Caster Wheels	Powertec Swivel Heavy Duty Caster	1	20.00
Front Wheels	MaxPower 335100 Lawn Mower Wheel	2	50.00
PCB	Ordered from JLCPCB (in quantities of 5)	1	2.00
Crystal	1xCSTCE16M0V53-R0 16MHz Crystal	1	1.00
Crystal	1xQS 16MHz Crystal	1	1.00
Inductor	1xBLM21(0805)	1	1.00
Reset Fuse	1xMF-MSMF050-2 500mA	1	1.00
Varistor	2xCG0603MLC-05E Varistor (0603)	2	2.00
Diodes	2xCD1206-S01575 Diode 100V, 150MA (1206)	2	2.00
Tactile Switch	1xTS42031-160R-TR-7260 Tactile Switch	1	1.00
Pin Header	2x(3x2M 2x03 Pin Header)	2	0.50
Pin Header	1x(2x2M -NM 2x02 Pin Header)	1	0.25
Pin Header	5x(8x1F-H8.5 1x08 Pin Header)	5	1.25
Pin Header	1x(10x1F-H8.5 1x10 Pin Header)	1	0.25
Pin Header	1x(18x2F-H8.5 2x18 Pin Header)	1	0.25
USB port	1xPN61729 USB-B Port	1	5.00
		Sub-Total (\$)	721.23
		Tax (7%)	771.72
		Shipping (\$)	100.00
		Total Cost (\$)	871.72
		Projected Cost Ceiling (\$)	2000

8.0 Conclusion

This section is the end of the project documentation. It identifies and describes project roles of all the interdisciplinary teams and individual roles, potential project design issues that arose from limitations of resources or constraints, future goals for the autonomous grass cutter, and a conclusion about this project documentation.

8.1 Project Roles

This project will be developed in conjunction with an Electrical and Computer Engineering Team, Computer Science Team and Mechanical Engineering Team. The focus of the Electrical Engineering Team is the hardware, software, power systems, and electrical design and implementation. This will include the power specifications to all the components, battery specifications, and the design, implementation and testing of the various components and Printed Circuit Board (PCB), and the software algorithms for the hardware. Individuals roles were assigned as shown in Table 61 below.

Table 61: Team Member's Project Roles

Team Member Name	Task
Brandei Dieter	-Ordering Parts -Hardware Design -Schematic Design -PCB Design -Motor Specifications
Christopher Entwistle	-Design Constraints -Standards -String-Based Blade Specifications -Charging System
Mario Mcclelland	-Software Design -ATmega2560 Programming -Motor Control Software -Ultrasonic Sensors Software -Camera Software -Communication with Raspberry Pi 3 Model B with ATmega2560 -Location and Positioning using the GPS/Compass Module
Daniel Warner	-Power Specifications -Battery Specifications -Motor Control Specifications
All Team Members	-Testing of Electrical Components -Testing of Breadboard Designs -Testing Accuracy of Components -Parts Selection -Technologies Selection

The focus of the Computer Science Team is the software algorithms of the Raspberry Pi Development Board. This will include the implementation of Computer Vision, path planning, image processing, wireless communications and the laptop application.

The focus of the Mechanical Engineering Team is the mechanical design of the grass cutter project. This will include designing and building the framework of the grass cutter, and overall motion of the wheels, grass cutter and string-based blades. They will also design the aerodynamics and mechanical functionalities of the overall device.

8.2 Potential Project Design Issues

Potential project design issues are discussed in this chapter. Limitations to the autonomous grass cutter's capabilities or functionality imposed upon by limited resources, design constraints, technological limitation or any other reason are identified and explained upon in the following subsections. Solution to the identified limitations to the autonomous grass cutter are included and further elaborated.

8.2.1 Navigation through Uneven Terrain

Caster wheels present a potential project design issue when it comes to navigating through uneven terrain. Stuck caster wheels hinder the autonomous grass cutters ability to safely navigate throughout the area of the solar farm. While the mechanical engineering team will try to mitigate this issue as much as possible, the reality is that the caster wheel will encounter wet or dry soil that will always been attempting to enter the bearings or trying to jam the caster wheel. Although the front wheels ultimately drive the autonomous grass cutter, a jammed caster wheel will not provide proper support because it will be dragging instead of rolling. The dragging of a jammed caster wheel will put an unnecessary load onto the autonomous grass cutter and could severely cut the efficiency down of the autonomous grass cutter.

Uneven terrain may also cause the robot motors to rotate at a slower rate or add strain to the resistance acting on the motors. This resistance will demand more power from the DC motors, thus draining more energy from the battery. If the motors get bogged down while attempting to climb a steep grade of terrain, the moment force counteracting the motor force may cause the wheel rotation to stop or reverse. This could potentially cause damaging power demands from the battery or other components. The power demanded by the motors on such grades is a problem that will be addressed by the mechanical engineering team working on this project.

The autonomous grass cutter has a remote kill switch implemented on the machine that is activated by an operating system application. The kill switch may be activated while the robot is located on a hill. It is possible that activation of the kill switch on a graded terrain can cause the autonomous grass cutter to be sent free-rolling down a hill once operations are terminated. Safety measures via electrical or mechanical means should be implemented to prevent this scenario.

8.2.2 Charge Regulator Limitations

The ideal charge time of the batteries are one to two hours. Due to power losses, temperatures, resources and cost, the batteries may or may not achieve this charge time. The more expensive batteries with a high charging rate may be too far of a reach with the design constraints of the project.

8.2.3 GPS and Digital Compass Limitations

GPS modules with high enough accuracy to implement a boundary zone are currently out of budget for this iteration of the autonomous grass cutter. While the GPS and digital compass module chosen for this project is accurate enough for the current design's application requirements, a GPS with higher accuracy could be used to establish an area of responsibility without the need for a boundary wire. As electronic components lower in cost, it is very possible that a GPS with high enough accuracy become available in future iterations. Additionally, making a boundary wire obsolete saves on the cost of implementing the boundary wire system currently implemented, allowing more of the budget to be allocated towards a higher fidelity GPS and digital compass module. One of the drawbacks that must be considered when using a GPS and digital compass module for boundary zone establishment is electromagnetic interference that may occur from other electronic components on the autonomous grass cutter or solar farm equipment.

8.2.4 Navigation and Object Avoidance

The robot uses computer vision and ultrasonic sensors to avoid obstacles. Navigating through the perimeter area using the computer vision aspect should prevent the robot from crashing into any of the obstacles. The ultrasonic sensors are installed on the robot to assure that, when turning to avoid obstructions with computer vision, the turning radius at the current speed of the robot is enough to fully avoid the obstacle. If the robot, while turning, is continuously moving in the path towards an object, then the sensors will send an activated signal for the grass-cutter to back up before progressing any further. The problem that may occur is that the sensors may produce a signal too early and cause the grass-cutter to reverse even though the object would have been avoided.

Establishing the correct distance away from the ultrasonic sensors before a signal is produced may be a difficult problem to overcome. The nearest the robot can cut grass next to an object, the more resourceful the design becomes. The accuracy in proximity of an object can be more precise if the computer vision application signals the object avoidance subsystem at an appropriate distance away to allow the sensors to be activated a correct amount of times. By this, it is implied that with just the sensors, the robot can fully approach an object cutting more area of grass next to that object without the use of computer vision. However, the average speed of the grass-cutter would decline if sensors were the only used mechanisms for object avoidance detection; negatively impacting the grass-cutters efficiency. The robot would constantly be changing direction. Therefore, computer vision is needed; if only computer vision was applied for detecting objects in the subsystem, the

robot would detect obstacles far away and maneuver around them leaving wide radiuses of uncut grass. In conclusion, both are required. The problem raised is at what distance each different part of this subsystem needs to detect an obstacle from.

8.2.5 String-Based Blade Limitations

Having the requirement of a string-based blade creates limitations to the capabilities that the autonomous grass cutter can have. Not everything on the ground can be avoided. When the autonomous grass cutter encounters objects such as infrastructure, trash or debris, it is likely that the nylon string will break in a fashion that either severely reduces the quality of the grass cut or completely inhibits further grass cutting operations. Mitigations such as self-feeding lines can be implemented at a higher cost per cutting blade, but they are only a temporary fix to the inherent durability issue that nylon string-based blades have.

String-based blades present a maintenance cost that is 2 factors: personnel and parts. Maintenance personnel or assignment of personnel is required to maintain what could possibly be a network of autonomous grass cutters and replacement string-based blades will create additional costs to the operation of the autonomous grass cutter. Also, unless the autonomous grass cutter has a system implemented that monitors the string-based blades, there is no way for any type of maintenance personnel to know whether the autonomous grass cutter's blades need attention.

8.3 Future Goals

During development of the project, some capabilities or ideas were not completely explored or implemented due to limitations from either resources or previously mentioned constraints. Future goals were created because the members developing the prototype saw that there were additional parts or components that could be added or swapped to increase either the capability or longevity of the autonomous grass cutter. This section of the documentation identifies and explains concepts or features that the design team would like to see implemented in future iterations of the autonomous grass cutter to improve upon its finished design.

8.3.1 Solar Panel Charging Station

Future goals of this project include having a solar panel charging station. It is very ideal to have this grass cutter automatically go back into its charging station that is energy efficient. The charging station would also provide a weather proof shelter for the robot. Due to limited time and resources of this project, the solar panel charging station is not feasible. In the future, this will significantly reduce the costs of having someone sent out to go charge the batteries.

8.3.2 Solar Panel on Grass Cutter

A solar panel on the top of the robot was discussed to save power and charge the secondary battery. This wasn't applied to the Grass Cutter project due to the cost. If the weather sensor

application is also activated and the Grass Cutter robot avoids rainy weather, a mounted solar panel would almost always be out in sunlight. This extra power would maximize battery life and be used as a secondary power source for the location beacon if the autonomous grass cutter were to get stuck and run out of the main battery source.

8.3.3 Computer Vision for Field Mapping

Another goal of this project is to have a camera map the entire field using Computer Vision and OpenCV. It would be very beneficial and more accurate with obstacle avoidance, path planning, and obstacle detection. Due to limited time and resources, this is not feasible with this project but a significant improvement in technology in the future.

8.3.4 Metal Blades for Durability

Having the autonomous robot operate for longer periods of time with less periodic maintenance requires more durable blades. It is simple to understand that a metal cutting blade would be more durable than a string-based blade. For this project, string-based blades were required by the customer to assure that the autonomous grass cutter would not damage or harm the solar farm's equipment or the students working on the project. Increasing blade durability would decrease the amount of routine maintenance required as well as improve the robots cutting capabilities.

As previously researched, a metal cutting blade can come with special capabilities such as lifting or mulching of the grass. The lifting or mulching capabilities that metal cutting blades offer would increase the aesthetic quality of the cut grass in terms of uniformity. Metal cutting blades also offer an advantage when compared to string-based blades because they do not require as much rotational speed, thus having a less stringent cutting motor requirement.

String-based blades cut grass by beating the grass in multiple attempts. The beating of the grass eventually cuts the grass, but also leaves the grass in a traumatized state from multiple passes of the string. Traumatized grass can cause the plant to possibly die, leaving an undesirable color to the solar farm. A metal blade is sharpened to cut the grass in one sweep, lessening the traumatization of the grass when cut. Of course, it goes without explanation that a metal blade for cutting presents obvious safety issues that must be addressed prior to implementation.

8.3.5 Weather Sensor Sheltering Application

Weather sensors, such as humidity or thermal sensors, added to the robot would enhance the efficiency of the grass-cutter by signaling it to go inside a charging station when the environmental conditions are not suitable for cutting. Efficiency would be increased because the autonomous grass cutter would not have to run during conditions that are not ideal. For example, wet grass can bog the locomotion and cutting motors, drawing extra power from the battery. By implementing weather sensors, the autonomous grass cutter can be programmed to only cut during conditions that are favorable to the battery which

can extend the overall range capability of the autonomous grass cutter. Additionally, programming the robot to cut during only ideal conditions can extend the lifespan of electrical and mechanical components.

8.4 Conclusion

In conclusion, this project, the Articulated AI-Assisted Solar Farm Grass Cutter project, is developed in conjunction with a team of Computer Science, Electrical Engineering, Computer Engineering, and Mechanical Engineering students. The prototype that is created will participate in a competition based on the cutting efficiency of the grass, features, practicality, locomotion, obstacle avoidance, obstacle detection and overall aesthetic completion of primary objectives (cutting grass). The focus of the ECE team will be the hardware, software, power systems, and electrical design. This includes power specifications for all the components, the design, implementation and testing of the various components, printed circuit boards (PCBs), and software algorithms for the hardware. The focus of the Computer Science team is to design and implement software algorithms using computer vision (CV) to aid in guidance, navigation and control of the grass cutter. The focus of the Mechanical Engineering team is to design and implement the framework, aerodynamics, and mechanical functionalities of the grass cutter.

The Articulated AI-Assisted Solar Farm Grass Cutter project has various technical requirements required by the sponsors Duke Energy and Orlando Utility Commission. Along with technical requirements, this project has additional constraints and challenges. After extensive research, applicable engineering standards and design constraints were identified in the documentation. Engineering standards specify characteristics that the project must meet. Identifying standards and applying their specifications ensures that components and environments in this project will be compatible with each other. Applying additional specifications on top of requirements introduced additional constraints when designing the prototype. This document identified all requirements, design constraints, and standards applicable to the project.

Chosen components were then identified along with an explanation of choice and comparison to other candidate parts. The combination of chosen components will ultimately make the electrical functions of the robot. The overall design of the hardware, software, testing and integration used to build the prototype were explained and shown in detail within the documentation. A series of subsystem tests were created to display the functionality of each component and design before the assembly of a prototype. This documentation contains test plans, procedures, results and the conclusion of the testing.

Finally, project milestones, potential design issues, PCB vendor information, future goals, and this conclusion were presented in the project documentation. Citations and copyright permissions are contained within the appendices of the project documentation. Combining the chosen parts along with the designs identified in this documentation results in a functioning prototype for the Articulated AI-Assisted Solar Farm Grass Cutter project.

A-Appendices

This section is used to show the Copyright Permissions and the works cited for the information provided and used in this document. Screenshots of permissions from various companies are shown in this chapter.

A1- Copyright Permissions

The copyright permissions requests and approvals are shown below. This is to ensure used information, data and images get the proper credit and follow copyright laws in this project documentation. In Figure 68 below, the permission request to Pololu is shown to use their information and images of their products on their website.

Copyright Permission



Brandei Dieter <Dietb@Knights.ucf.edu>

6:07 PM



To: support@pololu.com

To whom it may concern,

I'm currently writing a documentation for my Senior Design I Project that includes the use of your products.

May I have permission to use the information and images of your products from your website?

Thank you

Sincerely,
Brandei Dieter
Dietb@knights.ucf.edu
University of Central Florida

Sent from [Mail](#) for Windows 10

Figure 68: Pololu Permission Request

In Figure 69 below, the permission request to Adafruit Industries is shown to use their information and images of their products on their website.

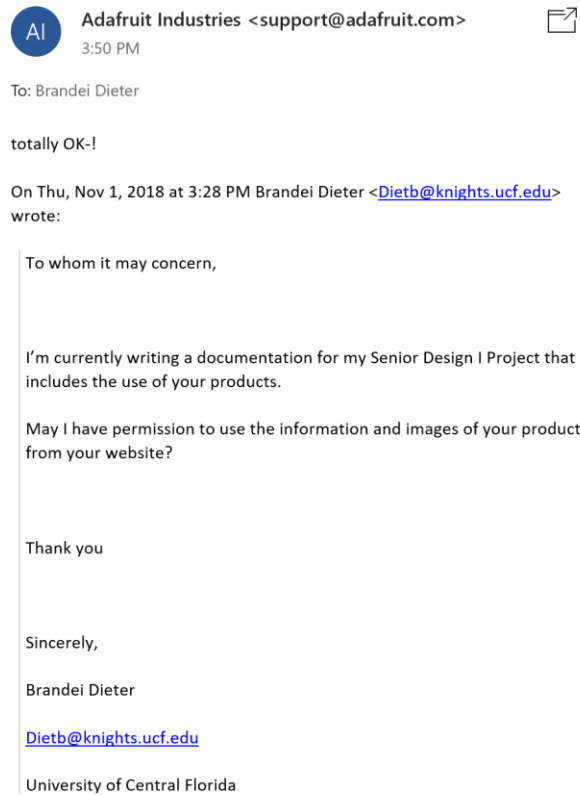

Figure 69: Adafruit Permission Request Approved

In Figure 70 below, the permission request to AliExpress is shown to use their information and images of their products on their website.



Figure 70: AliExpress Permission Request

In Figure 71 below, the permission request to Amazon is shown to use their information and images of their products on their website.

Copyright Permission

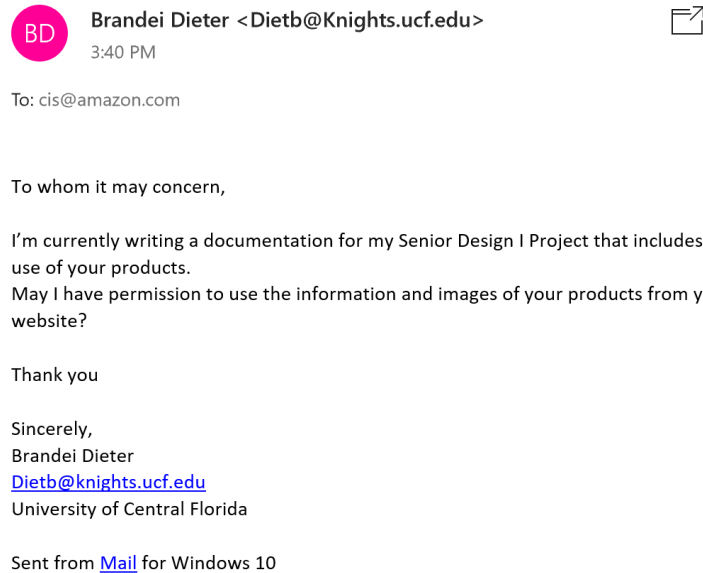

Figure 71: Amazon Permission Request

In Figure 72 below, the permission request to Digikey is shown to use their information and images of their products on their website.

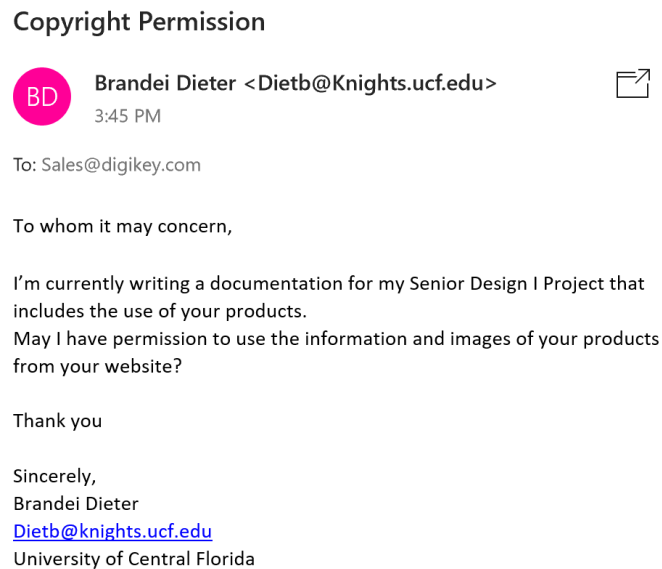

Figure 72: Digikey Permission Request

In Figure 73 below, the permission request to Robotshop is shown to use their information and images of their products on their website.

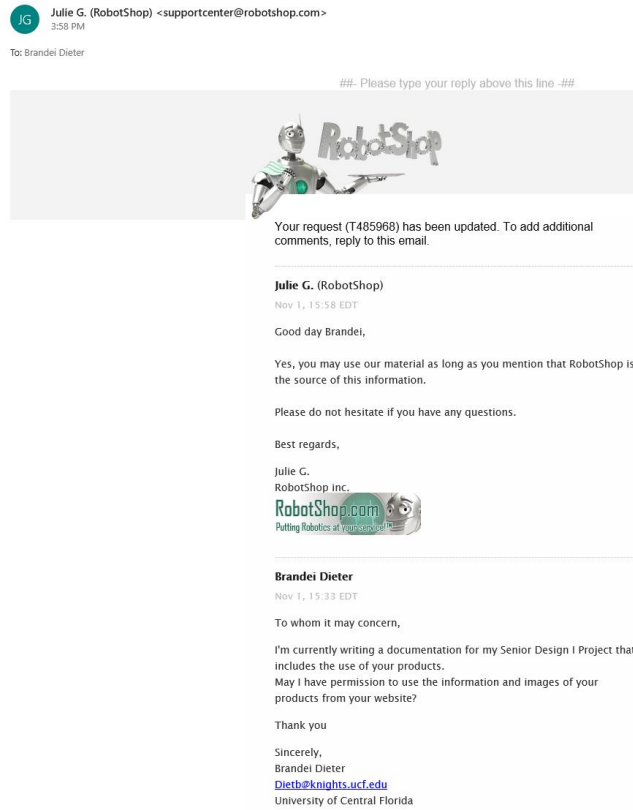

Figure 73: Robotshop Permission Request Approved

In Figure 74 below, the permission request to the author of an article from pubs.sciepub.com is shown to use their information on their website.

Copyright Permission



Figure 74: Permission Request

A2- Datasheets

This chapter shows the datasheets used in the part selection chapter. The datasheets are shown below in Table 62.

Table 62: Datasheets

#	Component	Datasheet Reference
[A1]	Crystal Oscillator	http://www.ecsxtal.com/store/pdf/hc_49us.pdf
[A2]	Arduino Mega	https://www.robotshop.com/media/files/pdf/arduino_mega2560datasheet.pdf
[A3]	Screw Terminal	http://www.on-shore.com/wp-content/uploads/2015/09/ostvnxxa150.pdf
[A4]	L293DNE Motor Driver	http://www.ti.com/lit/ds/symlink/l293d.pdf
[A5]	Female Headers	https://www.mill-max.com/assets/pdfs/065.pdf
[A6]	Male Headers	http://katalog.we-online.de/em/datasheet/6130xx11121.pdf
[A7]	LM2673 Voltage Regulator	http://www.ti.com/lit/ds/symlink/lm2673.pdf
[A8]	RLB Inductor	https://www.bourns.com/docs/Product-Datasheets/rlb.pdf
[A9]	LM324N Op-Amp	http://www.ti.com/lit/ds/symlink/lm324-n.pdf
[A10]	NE555P Timer	http://www.ti.com/lit/ds/symlink/ne555.pdf
[A11]	Raspberry Pi 3 Model B	https://www.terraelectronica.ru/pdf/show?pdf_file=%252Fds%252Fpdf%252FT%252FTechicRP3.pdf
[A12]	Micro M8N GPS Module	http://www.holybro.com/manual/Micro%20M8N%20Manual_v1.0.pdf
[A13]	HC-SR04 Ultrasonic Ranging Module	https://www.mouser.com/ds/2/813/HCSR04-1022824.pdf
[A14]	ATmega2560	http://ww1.microchip.com/downloads/en/devicedoc/atmel-2549-8-bit-avr-microcontroller-atmega640-1280-1281-2560-2561_datasheet.pdf
[A15]	USB Wi-Fi Module	https://media.digikey.com/pdf/Data%20Sheets/Adafruit%20PDFs/1030_Web.pdf
[A16]	LiPo Battery Charge Sensor	https://datasheets.maximintegrated.com/en/ds/MAX17043-MAX17044.pdf
[A17]	Raspberry Pi Night Vision Camera	https://www.marutsu.co.jp/contents/shop/marutsu/ds/114990837_Web.pdf
[A18]	LM2596 Regulator	http://www.ti.com/lit/ds/symlink/lm2596.pdf
[A19]	ATmega328P	https://www.sparkfun.com/datasheets/Components/SM/ATMega328.pdf
[A20]	Intel Curie	https://www.intel.com/content/dam/support/us/en/documents/boardsandkits/curie/Intel_Curie_Module_Datasheet_V1.21.pdf
[A21]	LM2596	http://www.ti.com/lit/ds/symlink/lm2596.pdf

The datasheets are shown below in Table 63.

Table 63: Datasheets

#	Component	Datasheet Reference
[A22]	ATmega16U2	http://ww1.microchip.com/downloads/en/DeviceDoc/doc7799.pdf
[A23]	LF351 Op-Amp	http://www.mouser.com/ds/2/149/LF351-189477.pdf
[A24]	CD4541B	http://www.ti.com/lit/ds/symlink/cd4541b.pdf
[A25]	Raspberry Pi Camera V2	http://www.farnell.com/datasheets/2056179.pdf
[A26]	Ping Ultrasonic Distance Sensor	https://www.parallax.com/sites/default/files/downloads/28015-PING-Sensor-Product-Guide-v2.0.pdf
[A27]	Arduino Infrared Collision Avoidance	http://www.rhydolabz.com/documents/26/IR_line_obstacle_detection.pdf
[A28]	BQ27441-G1 Fuel Gauge	http://www.ti.com/lit/ds/symlink/bq27441-g1.pdf

A3- References

This chapter will show all the citations of the resources used in this document.

- [1] Y. Saplakoglu, "The Planet is Dangerously Close to the Tipping Point for a "Hot House" Earth," 6 August 2018. [Online]. Available: <https://www.livescience.com/63267-hothouse-earth-dangerously-close.html>. [Accessed 30 10 2018].
- [2] C. O. S. Cochrum, "The Manscaper: Autonomous Lawn Mower," University of Central Florida, Orlando, 2013.
- [3] Husqvarna, "Husqvarna Robotic Lawn Mowers," November 2018. [Online]. Available: <https://www.husqvarna.com/us/>. [Accessed 31 10 2018].
- [4] S. K. S. B. T. S. J. J. M. J. James Sommer, "Autonomous Lawn Mower," Indiana University - Purdue University - Fort Wayne, Unknown.
- [5] Cyclone Rake, "Choosing Mower Blades," 30 10 2018. [Online]. Available: <https://www.cyclonerake.com/blog/choosing-mower-blades/>.
- [6] E. Z. Gomez, "Map-Building and Planning for Autonomous Navigation of a Mobile Robot," 01 2015. [Online]. Available: <https://www.ctrl.cinvestav.mx/~yuw/pdf/ErikZG.pdf>. [Accessed 20 11 2018].
- [7] J. Zijlmans, "LSD-slam and ORB-slam2, a literature based explanation," 23 08 2017. [Online]. Available: <https://medium.com/@j.zijlmans/lsd-slam-vs-orb-slam2-a-literature-based-comparison-20732df431d>. [Accessed 21 11 2018].
- [8] Arduino, "Compare Board Specs," 2018. [Online]. Available: www.arduino.cc/en/products/compare. [Accessed 20 11 2018].
- [9] A. Tantos, "H-Bridge Drivers," WordPress, 2011. [Online]. Available: http://www.modularcircuits.com/blog/articles/h-bridge-secrets/h-bridge_drivers/. [Accessed 25 11 2018].
- [10] ROHM semiconductor , "Controlling DC-Brush Motors with H-Bridge Driver ICs," 2009. [Online]. Available: www.rohm.com/documents/11308/12928/100260.H-BRDG_WPJ09.pdf. [Accessed 23 11 2018].
- [11] Power Electronics, "Dual, Full-Bridge PWM Motor Driver IC," Power Electronics, [Online]. Available: <https://www.powerselectronics.com/motion-systems/dual-full-bridge-pwm-motor-driver-ic>. [Accessed 25 11 2018].
- [12] Dynapar, "Motor Encoder Overview," Dynapar, 2018. [Online]. Available: https://www.dynapar.com/technology/encoder_basics/motor_encoders/. [Accessed 26 11 2018].
- [13] Anaheim Automation, "Encoder Guide," 2018. [Online]. Available: www.anaheimautomation.com/manuals/forms/encoder-guide.php. [Accessed 15 11 2018].
- [14] Allegro Micro Systems, "Brush DC Motor Drivers," Allegro Micro Systems, [Online]. Available: <https://www.allegromicro.com/en/Products/Motor-Driver-And-Interface-ICs/Brush-DC-Motor-Drivers.aspx>. [Accessed 24 11 2018].

- [15] Electrical Technology, "Brushless DC Motor (BLDC) – Construction, Working Principle & Applications," Electrical Technology, 17 11 2018. [Online]. Available: <https://www.electricaltechnology.org/2016/05/bldc-brushless-dc-motor-construction-working-principle.html>. [Accessed 22 11 2018].
- [16] C. Simpson, "Linear and Switching Voltage Regulator Fundamentals," Texas Instruments Incorporated, Dallas, Texas, 2011.
- [17] John, "Voltage Regulators," Circuits Today, 09 08 2018. [Online]. Available: <http://www.circuitstoday.com/voltage-regulators>. [Accessed 26 11 2018].
- [18] M. Day, "Understanding Low Drop Out (LDO) Regulators," Texas Instruments, 2006. [Online]. Available: <http://www.ti.com/lit/ml/slup239/slup239.pdf>. [Accessed 26 11 2018].
- [19] Texas Instruments, "DC/DC Buck Converters," Texas Instruments, 2018. [Online]. Available: <http://www.ti.com/power-management/non-isolated-dc-dc-switching-regulators/step-down-buck/buck-converter-integrated-switch/overview.html>. [Accessed 26 11 2018].
- [20] AllAboutCircuits, "All About Circuits," 1 09 2018. [Online]. Available: <https://www.allaboutcircuits.com/textbook/digital/chpt-4/switch-types/>.
- [21] J. Papiewski, "How do push button switches work in an electrical circuit?," Sciencing, 13 03 2018. [Online]. Available: <https://sciencing.com/push-switches-work-electrical-circuit-5030234.html>. [Accessed 20 11 2018].
- [22] RS Components, "Toggle Switches Overview," RS Components Pty Ltd, 2018. [Online]. Available: <https://au.rs-online.com/web/generalDisplay.html?file=electronics/toggle-switches&id=infozone>. [Accessed 19 11 2018].
- [23] Galco, "Selector Switches," Galco Industrial Electronics, 2018. [Online]. Available: <https://www.galco.com/comp/prod/switch-swnonill.htm>. [Accessed 20 11 2018].
- [24] Electro Sensors, "Speed Switch Tutorial," Electro-Sensor, Inc, 2018. [Online]. Available: <https://www.electro-sensors.com/applications/speed-switch-tutorial>. [Accessed 20 11 2018].
- [25] J. List, "DIODES: THE SWITCH YOU NEVER KNEW YOU HAD," Hackaday, 09 12 2016. [Online]. Available: <https://hackaday.com/2016/12/09/diodes-the-switch-you-never-knew-you-had/>. [Accessed 20 11 2018].
- [26] Computer Science, "Computer Programming Languages," Computer Science, 2018. [Online]. Available: <https://www.computerscience.org/resources/computer-programming-languages/>. [Accessed 17 11 2018].
- [27] OpenCV, "OpenCV," OpenCV Team, 2018. [Online]. Available: <https://opencv.org/about.html>. [Accessed 20 11 2018].
- [28] OpenCV, "Canny Edge Detection," OpenCV, 2018. [Online]. Available: https://docs.opencv.org/3.1.0/da/d22/tutorial_py_canny.html. [Accessed 22 11 2018].

- [29] Robotshop, "RobotShop Perimeter Wire Generator and Sensor Soldering Kit," 2018. [Online]. Available: <https://www.robotshop.com/en/robotshop-perimeter-wire-generator-sensor-soldering-kit.html>. [Accessed 1 11 2018].
- [30] Diffen.com, "Bluetooth vs. Wifi," Diffen, [Online]. Available: https://www.diffen.com/difference/Bluetooth_vs_Wifi. [Accessed 3 Dec 2018].
- [31] AIR 802, "IEEE 802.11 a/b/g/n Wi-Fi Standards and Facts," [Online]. Available: <https://www.air802.com/files/802-11-WiFi-Wireless-Standards-and-Facts.pdf>. [Accessed 14 11 2018].
- [32] I2C Info, "I2C Info - I2C Bus, Interface and Protocol," 30 Nov 2018. [Online]. Available: <http://i2c.info/>.
- [33] M. Grusin, "Serial Peripheral Interface (SPI)," SparkFun Electronics, 2018. [Online]. Available: <https://learn.sparkfun.com/tutorials/serial-peripheral-interface-spi/all>. [Accessed 30 11 2018].
- [34] Circuit Basics, "Basics of UART Communication," Stanford, [Online]. Available: <https://web.stanford.edu/class/cs140e/notes/lec4/uart-basics.pdf>. [Accessed 30 11 2018].
- [35] Terra Electronica, "Raspberry Pi 3 Model B," 2018. [Online]. Available: https://www.terraelectronica.ru/pdf/show?pdf_file=%252Fds%252Fpdf%252FT%252FTechicRP3.pdf. [Accessed 15 11 2018].
- [36] Adafruit, "Raspberry Pi 3 - Model B - ARMv8 with 1GB RAM," Raspberry Pi, 2018. [Online]. Available: <https://www.adafruit.com/product/3055>. [Accessed 15 11 2018].
- [37] Mantech, "Arduino Mega 2560," Arduino, [Online]. Available: <http://www.mantech.co.za/datasheets/products/a000047.pdf>. [Accessed 15 11 2018].
- [38] Arduino, "Arduino Mega 2560 Rev3," Arduino, [Online]. Available: <https://store.arduino.cc/usa/arduino-mega-2560-rev3>. [Accessed 14 11 2018].
- [39] Microchip, "Atmel ATmega640/V-1280/V-1281/V-2560/V-2561/V," Atmel, 2018. [Online]. Available: http://ww1.microchip.com/downloads/en/devicedoc/atmel-2549-8-bit-avr-microcontroller-atmega640-1280-1281-2560-2561_datasheet.pdf. [Accessed 20 11 2018].
- [40] Mouser Electronics, "ATMEGA16U2-MU," Microchip Technology/Atmel, 2018. [Online]. Available: https://www.mouser.com/ProductDetail/Microchip-Technology-Atmel/ATMEGA16U2-MU?qs=JV7lzlMm3yIZlyznMyuPNA%3D%3D&gclid=Cj0KCQiAxZPgBRCmARIsAOrTHSYDb8iStbfOLIArAGXmqeCas3pdgu6mapnGGuCMxJUWeaGNI NTReR0aAoliEALw_wcB. [Accessed 1 12 2018].
- [41] Microchip, "ATmega16U2," Microchip, 2018. [Online]. Available: <https://www.microchip.com/wwwproducts/en/ATmega16u2>. [Accessed 20 11 2018].
- [42] Amazon, "McCulloch 589402402 Automower Boundary Wire (150M)," McCulloch, 2018. [Online]. Available: <https://www.amazon.com/McCulloch->

- 589402402-Automower-Boundary-Wire/dp/B06XQ2SW9H/ref=asc_df_B06XQ2SW9H/?tag=hyprod-20&linkCode=df0&hvadid=198123788296&hvpos=1o1&hvnetw=g&hvrnd=2535187872125767586&hvppone=&hvptwo=&hvqmt=&hvdev=c&hvdvcm dl=&hvl ocint=&hvlocph. [Accessed 10 11 2018].
- [43] eXtreme Dog Fence, "eXtreme Dog Fence 16 Gauge Boundary Wire," eXtreme, 2018. [Online]. Available: https://www.extremedogfence.com/product/extreme-dog-fence-16-gauge-boundary-wire/?gclid=Cj0KCQiAxZPgBRCmARIsAOrTHSZLK0OSMGf38FbUm0VR_M2CKMyeUVelCUjkPmI9HcFKPAM2oSBgUUkaAiYcEALw_wcB. [Accessed 30 11 2018].
- [44] Texas Instruments, "xx555 Precision Timers," Texas Instruments, 09 2014. [Online]. Available: <http://www.ti.com/lit/ds/symlink/ne555.pdf>. [Accessed 20 11 2018].
- [45] Texas Instruments, "CMOS Programmable Timer High Voltage Types (20V Rating)," Texas Instruments, 2003. [Online]. Available: <http://www.ti.com/lit/ds/symlink/cd4541b.pdf>. [Accessed 30 11 2018].
- [46] Texas Instruments, "LMx24-N, LM2902-N Low-Power, Quad-Operational Amplifier," Texas Instruments, 01 2015. [Online]. Available: <http://www.ti.com/lit/ds/symlink/lm324-n.pdf>. [Accessed 29 11 2018].
- [47] Mouser Electronics, "LF351 Single Operational Amplifier (JFET)," FAIRCHILD Semiconductor, 2001. [Online]. Available: <http://www.mouser.com/ds/2/149/LF351-189477.pdf>. [Accessed 30 11 2018].
- [48] Seeed, "Raspberry Pi Infrared Camera Module," Marutsu, [Online]. Available: https://www.marutsu.co.jp/contents/shop/marutsu/ds/114990837_Web.pdf. [Accessed 18 11 2018].
- [49] Farnell, "Raspberry Pi Camera V2," Farnell, [Online]. Available: <http://www.farnell.com/datasheets/2056179.pdf>. [Accessed 20 11 2018].
- [50] ELEC Freaks, "Ultrasonic Ranging Module HC-SR04," Mouser Electronics, [Online]. Available: <https://www.mouser.com/ds/2/813/HCSR04-1022824.pdf>. [Accessed 19 11 2018].
- [51] Parallax, "Ping Ultrasonic Distance Sensor (#28015)," Parallax, [Online]. Available: <https://www.parallax.com/sites/default/files/downloads/28015-PING-Sensor-Product-Guide-v2.0.pdf>. [Accessed 20 11 2018].
- [52] RHYDOLABZ, "Arduino Infrared Collision Avoidance," RHYDOLABZ, [Online]. Available: http://www.rhydolabz.com/documents/26/IR_line_obstacle_detection.pdf. [Accessed 19 11 2018].
- [53] MAXIM, "Compact, Low-Cost 1S/2S Fuel Gauges with Low-Battery Alert," DigChip, 04 2010. [Online]. Available: https://www.digchip.com/datasheets/download_datasheet.php?id=3258456&part-number=MAX17043. [Accessed 30 11 2018].

- [54] Texas Instruments, "bq274441-G1 System-Side Impedance Track Fuel Gauge," Texas Instruments, 2014. [Online]. Available: <http://www.ti.com/lit/ds/symlink/bq27441-g1.pdf>. [Accessed 30 11 2018].
- [55] Newegg, "GP-Xtreme Mini Compact USB 2.0 Wireless N 802.11n/g WiFi Newtork Dongle Adapter GP-5371N," Newegg, 2018. [Online]. Available: <https://www.newegg.com/Product/Product.aspx?Item=0B1-00FJ-00001>. [Accessed 23 11 2018].
- [56] Adafruit, "USB WiFi (802.11b/g/n) Module with Antenna for Raspberry Pi," Adafruit, 2018. [Online]. Available: <https://www.adafruit.com/product/1030>. [Accessed 18 11 2018].
- [57] Texas Instruments, "DRV8842 DC Motor Driver IC," Texas Instruments, 03 2018. [Online]. Available: <http://www.ti.com/lit/ds/symlink/drv8842.pdf>. [Accessed 2 12 2018].
- [58] Texas Instruments, "L293x Quadruple Half-H Drivers," Texas Instruments, 01 2016. [Online]. Available: <http://www.ti.com/lit/ds/symlink/l293.pdf>. [Accessed 14 11 2018].
- [59] Banggood, "DC 12V 180RPM Geared Motor High Torque Gear Reducer Motor," Banggood, 2018. [Online]. Available: https://www.banggood.com/DC-12V-180RPM-Geared-Motor-High-Torque-Gear-Reducer-Motor-p-1068573.html?rmmds=detail-bottom-alsoBought__2&cur_warehouse=CN. [Accessed 18 11 2018].
- [60] Robotshop, "Cytron 12V 17RPM 194.4oz-in Spur Gearmotor," Robotshop, 2018. [Online]. Available: <https://www.robotshop.com/en/cytron-12v-17rpm-1944oz-in-spur-gearmotor.html>. [Accessed 18 11 2018].
- [61] Banggood, "Machifit 895 Motor Large Torque Gear Motor," Machifit, 2018. [Online]. Available: https://www.banggood.com/Machifit-775-795-895-MotorMotor-Bracket-DC-12V-24V-3000-12000RPM-Motor-Large-Torque-Gear-Motor-p-1342261.html?rmmds=home-right-flashDeal&ID=511154&cur_warehouse=CN. [Accessed 03 12 2018].
- [62] Robotshop, "RS-775 Motor 7000rpm," 2018. [Online]. Available: <https://www.robotshop.com/en/rs-775-motor-7000rpm-12v-7613oz-in.html>. [Accessed 2 12 2018].
- [63] Texas Instruments, "LM2596 Simple Switches Power Converter 150-kHz 3-A Step-Down Voltage Regulator," Texas Instruments, 05 2016. [Online]. Available: <http://www.ti.com/lit/ds/symlink/lm2596.pdf>. [Accessed 20 11 2018].
- [64] Texas Instruments, "LM2673 Simple Switcher 3-A Step-Down Voltage Regulator With Adjustable Current Limit," Texas Instruments, 06 2016. [Online]. Available: <http://www.ti.com/lit/ds/symlink/lm2673.pdf>. [Accessed 20 11 2018].
- [65] Alibaba, "New Design High Quality 12V 60Ah 80Ah 160Ah high capacity lipo battery for electric car," DMD, 2018. [Online]. Available: https://www.alibaba.com/product-detail/New-design-high-quality-12v-60ah_60562778506.html?spm=a2700.galleryofferlist.normalList.2.14a0e3e0NYN8O2. [Accessed 20 11 2018].

- [66] Alibaba, "BMS Lithium dry cell rechargeable solar panel system battery pack lithium 12V 100Ah 200Ah," DMD, 2018. [Online]. Available: https://www.alibaba.com/product-detail/BMS-lithium-dry-cell-rechargeable-solar_60551849917.html?spm=a2700.details.maylikehoz.2.107c21169viUHM. [Accessed 20 11 2018].
- [67] Alibaba, "LiPo 18650 Li-Ion Laptop batteries 12V 24V nominal voltage exide battery 60Ah 80Ah 100Ah 200Ah," DMD, 2018. [Online]. Available: https://www.alibaba.com/product-detail/Lipo-18650-li-ion-laptop-batteries_60694370113.html?spm=a2700.galleryofferlist.normalList.464.14a0e3e0NYN8O2. [Accessed 20 11 2018].
- [68] Alibaba, "Shenzhen Manufacturer 12V 20Ah LiPo Batteries Pack Scooter Batteries with BMS," Shenzhen, 2018. [Online]. Available: https://www.alibaba.com/product-detail/Shenzhen-Manufacturer12V-20Ah-Lipo-Batteries-Pack_60780688154.html?spm=a2700.7724838.2017115.62.3bf031084Re17O. [Accessed 21 11 2018].
- [69] Alibaba, "12V 20Ah Lithium Ion RC LiPo Battery for UAV drone multirotor RC model," Yinkai Power, 2018. [Online]. Available: https://www.alibaba.com/product-detail/12v-20ah-lithium-ion-rc-lipo_60437172688.html?spm=a2700.7724838.2017115.110.3bf031084Re17O. [Accessed 22 11 2018].
- [70] Alibaba, "12v 10ah lithium ion polymer rechargeable lipo battery for single wheel e-bike," Alibaba, 2018. [Online]. Available: https://www.alibaba.com/product-detail/12v-10ah-lithium-ion-polymer-rechargeable_60243016365.html?spm=a2700.7724838.2017115.123.6029537cu2wmBx. [Accessed 19 11 2018].
- [71] Alibaba, "Professional Supply Li-ion Battery Rechargeable Lithium Lipo 12v 10ah Battery Pack," Alibaba, 2018. [Online]. Available: https://www.alibaba.com/product-detail/Professional-Supply-Li-ion-Battery-Rechargeable_60819337407.html?spm=a2700.7724838.2017115.145.6029537cu2wmBx. [Accessed 19 11 2018].
- [72] MaxPower, "Maxpower 335100 10-Inch by 1-3/4-Inch Plastic Lawn Mower Wheel," Amazon, 2018. [Online]. Available: <https://www.amazon.com/Maxpower-335100-10-Inch-4-Inch-Plastic/dp/B001F0Z7FW>. [Accessed 27 11 2018].
- [73] Arnold, "Arnold 10-Inch Steel Wheel," Home Depot, 2018. [Online]. Available: <https://www.homedepot.com/p/Arnold-10-in-Steel-Wheel-490-323-0001/206704965>. [Accessed 27 11 2018].
- [74] IEEE, "IEEE 1679.1-2017 - IEEE Guide for the Characterization and Evaluation of Lithium-Based Batteries in Stationary Applications," 2017. [Online]. Available: https://standards.ieee.org/standard/1679_1-2017.html. [Accessed 14 11 2018].

- [75] IEEE Standards Association, "1625-2008- IEEE Standard for Rechargeable Batteries for Multi-Cell Mobile Computing Devices," 2008. [Online]. Available: <https://ieeexplore.ieee.org/document/4657368>. [Accessed 14 11 2018].
- [76] ISO, "ISO/IEC 9899:2018 - Information technology -- Programming languages -- C," 27 Nov 2018. [Online]. Available: <https://www.iso.org/standard/74528.html>.
- [77] IEEE, "29119-1-2013 - ISO/IEC/IEEE International Standard - Software and systems engineering -- Software testing -- Part1:Concepts and definitions - IEEE Standard," 20 Nov 2018. [Online]. Available: <https://ieeexplore.ieee.org/document/6588537>.
- [78] IEEE, "29119-2-2013 - ISO/IEC/IEEE International Standard - Software and systems engineering -- Software testing -- Part2:Test processes - IEEE Standard," 20 Nov 2018. [Online]. Available: <https://ieeexplore.ieee.org/document/6588543>.
- [79] IEEE, "29119-3-2013 - ISO/IEC/IEEE International Standard - Software and systems engineering -- Software testing -- Part 3:Test documentation - IEEE Standard," 20 Nov 2018. [Online]. Available: <https://ieeexplore.ieee.org/document/6588540>.
- [80] IEEE, "29119-4-2015 - ISO/IEC/IEEE International Standard - Software and systems engineering--Software testing--Part 4: Test techniques - IEEE Standard," 20 Nov 2018. [Online]. Available: <https://ieeexplore.ieee.org/document/7346375>.
- [81] IEEE, "29119-5-2016 - ISO/IEC/IEEE International Standard - Software and systems engineering -- Software testing -- Part 5: Keyword - Driven Testing - IEEE Standard," 20 Nov 2018. [Online]. Available: <https://ieeexplore.ieee.org/document/7750539>.
- [82] IEEE, "1873-2015 - IEEE Standard for Robot Map Data Representation for Navigation - IEEE Standard," 20 Nov 2018. [Online]. Available: <https://ieeexplore.ieee.org/document/7300355>.
- [83] ISO, "ISO 8373:2012 - Robots and robotic devices -- Vocabulary," 29 Nov 2018. [Online]. Available: <https://www.iso.org/standard/55890.html?browse=tc>.
- [84] IEC, "IEC 62680-1-1:2015 | IEC Webstore | energy, multimedia, USB, LVDC," 20 Nov 2018. [Online]. Available: <https://webstore.iec.ch/publication/23281>.
- [85] IEC, "IEC 62680-1-2:2018 | IEC Webstore | energy, multimedia, USB, LVDC," 20 Nov 2018. [Online]. Available: <https://webstore.iec.ch/publication/60944>.
- [86] IEC, "IEC 62680-1-3:2018 | IEC Webstore | energy, multimedia, USB, LVDC," 20 Nov 2018. [Online]. Available: <https://webstore.iec.ch/publication/61599>.
- [87] IEC, "IEC 62680-1-4:2018 | IEC Webstore | energy, multimedia, USB, LVDC," 20 Nov 2018. [Online]. Available: <https://webstore.iec.ch/publication/60748>.
- [88] IEC, "IEC 62680-2-1:2015 | IEC Webstore | energy, multimedia, USB, LVDC," 20 Nov 2018. [Online]. Available: <https://webstore.iec.ch/publication/23313>.
- [89] IEC, "IEC 62680-2-2:2015 | IEC Webstore | energy, multimedia, USB, LVDC," 20 Nov 2018. [Online]. Available: <https://webstore.iec.ch/publication/23282>.
- [90] IEC, "IEC 62680-2-3:2015 | IEC Webstore | energy, multimedia, USB, LVDC," 20 Nov 2018. [Online]. Available: <https://webstore.iec.ch/publication/23283>.

- [91] IEC, "IEC 62680-3-1:2017 | IEC Webstore | energy, multimedia, USB, LVDC," 20 Nov 2018. [Online]. Available: <https://webstore.iec.ch/publication/29943>.
- [92] IEC, "CISPR 14-1:2016 | IEC Webstore | electromagnetic compatibility, EMC, smart city," 20 Nov 2018. [Online]. Available: <https://webstore.iec.ch/publication/25633>.
- [93] IEC, "CISPR 14-2:2015 RLV | IEC Webstore | electromagnetic compatibility, EMC, smart city," 24 Nov 2018. [Online]. Available: <https://webstore.iec.ch/publication/22136>.
- [94] IEC, "IEC 61000-6-3:2006+AMD:2010 CSV | IEC Webstore | electromagnetic compatibility. EMC, smart city, rural electrification," 24 Nov 2018. [Online]. Available: <https://webstore.iec.ch/publication/4247>.
- [95] IEC, "IEC 61000-6-4:2018 RLV | IEC Webstore | electromagnetic compatibility, EMC, smart city," 24 Nov 2018. [Online]. Available: <https://webstore.iec.ch/publication/62637>.
- [96] JLCPCB, "PCB Fabrication Services," 2018. [Online]. Available: <https://support.jlpcb.com/article/41-pcb-fabrication-services>. [Accessed 31 10 2018].
- [97] JLCPCB, "Shipping & Delivery," 2018. [Online]. Available: <https://support.jlpcb.com/article/27-shipping-delivery>. [Accessed 31 10 2018].
- [98] JLCPCB, "Capabilities," 2018. [Online]. Available: <https://jlpcb.com/capabilities/Capabilities>. [Accessed 31 10 2018].
- [99] Robomow Friendly House, "The History of Lawn Mowers," Robomow Friendly House, 20 September 2015. [Online]. Available: <https://www.robomow.com/en-GB/history-lawn-mowers/>. [Accessed 20 October 2018].
- [100] O. J. Woodman, "An introduction to inertial navigation," *Technical Report*, p. 37, 2007.
- [101] R. Burnett, "Ultrasonic vs Infrared (IR) Sensors – Which is better?," 27 11 2017. [Online]. Available: <https://www.maxbotix.com/articles/ultrasonic-or-infrared-sensors.htm>. [Accessed 30 10 2018].
- [102] Wikipedia, "Passive infrared sensor," [Online]. Available: https://en.wikipedia.org/wiki/Passive_infrared_sensor. [Accessed 30 10 2018].
- [103] A. G, "Perimeter Wire / BWF," 19 08 2013. [Online]. Available: <https://www.ardumower.de/index.php/en/induktion>. [Accessed 31 10 2018].
- [104] Amazon, "Raspberry Pi 3 B+/3B Full Function Motor Hat, Robot Expansion Board," 2018. [Online]. Available: https://www.amazon.com/Raspberry-Function-Expansion-Support-Stepper/dp/B0721MTJ3P/ref=pd_cp_147_2?pf_rd_m=ATVPDKIKX0DER&pf_rd_p=ef4dc990-a9ca-4945-ae0b-f8d549198ed6&pf_rd_r=V8J31TE1000RM8JJYFAC&pf_rd_wg=1GcH7&pf_rd_s=desktop-dp-sims&pf_rd_t=40701&pf_rd_w=. [Accessed 1 11 2018].
- [105] Amazon, "WINGONEER Capacitors," 2018. [Online]. Available: <https://www.amazon.com/WINGONEER-Capacitors-Values-Electrolytic->

- Assortment/dp/B0711SCBPQ/ref=sr_1_3?ie=UTF8&qid=1541092980&sr=8-3&keywords=capacitors+kit. [Accessed 1 11 2018].
- [106] Amazon, "EAONE 850 Pieces 30 Values 1% Resistor Kit," 2018. [Online]. Available: https://www.amazon.com/EAONE-Resistor-Resistors-Assortment-Experiments/dp/B076LH75JQ/ref=sr_1_6?ie=UTF8&qid=1541092929&sr=8-6&keywords=resistors+kit. [Accessed 1 11 2018].
- [107] AliExpress, "Source Hardware Module Flight Control Board ArduIMU+ V3 for Arduino," 2018. [Online]. Available: https://www.aliexpress.com/item/Open-Source-Hardware-Module-Flight-Control-Board-ArduIMU-V3-for-Arduino-DIY/32817752346.html?spm=2114.search0104.3.2.7f1477bckVoPeK&ws_ab_test=searchweb0_0,searchweb201602_1_10065_10068_10130_318_10890_10547_319_10546_57313. [Accessed 1 11 2018].
- [108] Amazon, "Striveday 30 AWG Flexible Silicone Wire," 2018. [Online]. Available: https://www.amazon.com/StrivedayTM-Flexible-Silicone-electronic-electrics/dp/B01KQ2JNLI/ref=sr_1_4?ie=UTF8&qid=1541093132&sr=8-4&keywords=wires+for+circuits. [Accessed 1 11 2018].
- [109] Adafruit, "USB WiFi (802.11b/g/n) Module with Antenna for Raspberry Pi," 2018. [Online]. Available: <https://www.adafruit.com/product/1030>. [Accessed 1 11 2018].
- [110] Adafruit, "Raspberry Pi 3 - Model B+ - 1.4GHz Cortex-A53 with 1GB RAM," 2018. [Online]. Available: <https://www.adafruit.com/product/3775?src=raspberrypi>. [Accessed 1 11 2018].
- [111] Robotshop, "HC-SR04 Ultrasonic Range Finder," 2018. [Online]. Available: https://www.robotshop.com/en/hc-sr04-ultrasonic-range-finder.html?gclid=CjwKCAjwyOreBRAYEiwAR2mSknjfBFS52Rb3_iak4Acf6jqRKCn1Fa8TVPNLZLFUcyY6T0uV375K7xoCaPoQAvD_BwE. [Accessed 1 11 2018].
- [112] Pololu, "Dagu Wild Thumper Wheel 120x60mm Pair with 4mm Shaft Adapters - Chrome," 2018. [Online]. Available: <https://www.pololu.com/product/1557>. [Accessed 1 11 2018].
- [113] AliExpress, "HK LittoKala 24V 12AH 6S6P Lithium Battery Pack," 2018. [Online]. Available: https://www.aliexpress.com/item/LiitoKala-24v-12ah-6S6P-lithium-battery-pack-25-2V-12ah-battery-li-ion-for-bicycle-battery/32809085810.html?src=google&albslr=202339875&src=google&albch=shopping&acnt=494-037-6276&isdl=y&slnk=&plac=&mtctp=&albbt=Google_7_sh. [Accessed 1 11 2018].
- [114] "Comparing Python to Other Languages," 1997. [Online]. Available: <https://www.python.org/doc/essays/comparisons/>.
- [115] Amazon, "Qunqi L298N Motor Drive Controller Board Module Dual H Bridge DC Stepper," 2018. [Online]. Available: https://www.amazon.com/Qunqi-Controller-Module-Stepper-Arduino/dp/B014KMHSW6/ref=sr_1_fkmr0_1?s=hi&ie=UTF8&qid=1541115943&sr=1-1-fkmr0&keywords=Arduino+L289N. [Accessed 1 11 2018].

- [116] Battery University, "BU-201: How does the Lead Acid Battery Work?," 1 November 2018. [Online]. Available: https://batteryuniversity.com/learn/article/lead_based_batteries.
- [117] Battery University, "BU-203: Nickel-Based Batteries," 1 November 2018. [Online]. Available: https://batteryuniversity.com/learn/article/nickel_based_batteries.
- [118] Battery University, "BU-204: How do Lithium Batteries Work?," 1 November 2018. [Online]. Available: https://batteryuniversity.com/learn/article/lithium_based_batteries.
- [119] Home Depot, "6 in. Air-Ride Pneumatic Rubber Swivel Caster," 2018. [Online]. Available: https://www.homedepot.com/p/SNAP-LOC-6-in-Air-Ride-Pneumatic-Rubber-Swivel-Caster-SLAC6AS/206603238?cm_mmc=Shopping%7CG%7CBase%7CD25H%7C25-4_BUILDERS_HARDWARE%7CNA%7CPLA%7c71700000035978695%7c58700004046980559%7c92700037059910574&gclid=CjwKCAjw6-_eBRBXEiw. [Accessed 1 11 2018].
- [120] Mouser Electronics, "Arduino Uno," 2018. [Online]. Available: https://www.mouser.com/ProductDetail/Arduino/A000066?qs=BC3YYPaifMrIue9b%252bHtKQg%3D%3D&gclid=CjwKCAjw6-_eBRBXEiwA-5zHadtC7Yrihp_NIKSEGVCOYEz60UUb714sNa5VKf8bL0-gf0VPTGkrfRoCKRAQAvD_BwE. [Accessed 1 11 2018].
- [121] Bdaouas, "DIY Perimeter Wire Generator and Sensor," 12 2017. [Online]. Available: <https://www.robotshop.com/community/forum/t/diy-perimeter-wire-generator-and-sensor-robotshop-community/31190>. [Accessed 2 11 2018].
- [122] Echo, "Echo USA," 15 November 2018. [Online]. Available: <https://www.echo-usa.com>.
- [123] John Deere, "John Deere Tango E5 Autonomous Mower," November 2018. [Online]. Available: https://www.deere.co.uk/en_GB/products/equipment/autonomous_mower/tango_e5/tango_e5.page. [Accessed 31 10 2018].
- [124] ISO, "ISO/IEC 9899:1999 - Programming languages -- C," 27 Nov 2018. [Online]. Available: <https://www.iso.org/standard/29237.html>.
- [125] ISO, "ISO/IEC 9899:2011 - Information Technology -- Programming languages - C," 27 Nov 2018. [Online]. Available: <https://www.iso.org/standard/57853.html>.
- [126] J. Miller, "Brushless Motor vs Brush Motors, what's the difference?," 27 07 2014. [Online]. Available: <https://www.quantumdev.com/brushless-motors-vs-brush-motors-whats-the-difference/>. [Accessed 27 11 2018].
- [127] ISO, "ISO 9283:1998 - Manipulating industrial robots -- Performance criteria and related test methods," 29 Nov 2018. [Online]. Available: <https://www.iso.org/standard/22244.html?browse=tc>.
- [128] ISO, "ISO 9787:2013 - Robots and robotic devices -- Coordinate systems and motion nomenclatures," 29 Nov 2018. [Online]. Available: <https://www.iso.org/standard/59444.html?browse=tc>.

- [129] ISO, "ISO 10218-2:2011 - Robots and robotic devices -- Safety requirements for industrial robots -- Part 2: Robot systems and integration," 29 Nov 2018. [Online]. Available: <https://www.iso.org/standard/51330.html?browse=tc>.
- [130] ISO, "ISO 10218-1:2011 - Robots and robotic devices -- Safety requirements for industrial robots -- Part 1: Robots," 29 Nov 2018. [Online]. Available: <https://www.iso.org/standard/51330.html?browse=tc>.
- [131] ISO, "ISO 18646-1:2016 - Robotics -- Performance criteria and related test methods for service robots -- Part 1: Locomotion for wheeled robots," 29 Nov 2018. [Online]. Available: <https://www.iso.org/standard/63127.html?browse=tc>.
- [132] Bluetooth Special Interest Group, "Radio Versions | Bluetooth Technology Website," 2 December 2018. [Online]. Available: <https://www.bluetooth.com/bluetooth-technology/radio-versions>.
- [133] Texas Instruments , "Dual Full Bridge PWM Motor Driver," 22 Feb 2009. [Online]. Available: www.ti.com/lit/ds/symlink/drv8402.pdf. [Accessed 01 Nov 2018].