

**M-GU4RD**  
*Medical GPS Unit Active Response Duty*



**University of Central Florida**  
**Senior Design II**  
**Spring 2019**

**Group 9**

Andrew Lucena	Electrical Engineering
Angello Garcia	Electrical Engineering
Giovanni Martinez	Electrical Engineering
Italo Travi	Computer Engineering

## Table of Contents

List of Figures .....	iv
List of Tables .....	vi
1.0 Executive Summary .....	1
2.0 Introduction.....	3
2.1 Firefighter Application.....	3
2.2 Military Application.....	5
2.3 Police Application.....	6
2.4 Medical Application.....	7
3.0 Project Description & Design Ideas.....	9
3.1 Research of existing Projects and Products.....	10
3.2 Functional Block Diagram .....	11
3.3 Objective/Goals.....	12
3.4 Brainstorming.....	12
3.5 Motivation .....	14
3.6 Functional Requirements.....	14
3.7 House of Quality .....	15
3.8 Demonstrable Requirements .....	16
3.8.1 Changes Made in Senior Design 2 .....	17
3.9 Problems Encountered.....	17
4.0 Research & Part Selection .....	19
4.1 Microprocessor/Microcontroller Selection .....	20
4.1.1 Microprocessors .....	20
4.1.2 Microcontrollers.....	23
4.1.3 Changes Made in Senior Design 2 .....	31
4.2 Biometric Sensor Selection.....	31
4.2.1 Medical Development Boards.....	33
4.2.2 Vital Sensors (ECG & Body Temperature).....	38
4.2.3 Changes Made in Senior Design 2 .....	42
4.3 Global Positioning System (GPS) Selection.....	43
4.4 Wireless Communication Options .....	48
4.4.1 Wi-Fi (2.4 GHz – 5 GHz).....	48
4.4.2 Bluetooth (2.402 GHz – 2.480 GHz) .....	49
4.4.3 Radio Frequency Module.....	50
4.5 Antennas .....	57
4.6 Selection of RF Module.....	63
4.7 Altimeter Sensor .....	66
4.8 Power Control Unit (PCU) Selection.....	65
4.8.1 Changes Made in Senior Design 2 .....	68

4.9 Display Selection (GUI) .....	69
4.9.1 Changes Made in Senior Design 2 .....	70
4.10 Additional Component Selection .....	71
4.11 Final Components Selection .....	73
5.0 Design Constraints & Standards .....	75
5.1 Development Constraints .....	75
5.2 Health Insurance Portability & Accountability Act (HIPAA) .....	76
5.3 Limitation in RF Module .....	78
5.3.1 Range and Frequency .....	78
5.3.2 Antenna High and Fresnel Zone .....	79
5.3.3 FCC Constraints .....	80
5.4 Economic and Time Constraints .....	81
5.5 Environmental, Social and Political Constraints .....	81
5.6 Manufacturability and Sustainability Constraints .....	82
5.7 Software Standards .....	82
5.7.1 Test Processes .....	82
5.7.2 Test Documentation .....	83
5.8 Hardware Constraints & Standards .....	84
5.9 Programming Language Standards .....	85
5.10 Battery Standards .....	86
6.0 Project Design .....	88
6.1 Hardware Design .....	88
6.2 Printable Circuit Board (PCB) .....	89
6.2.1 Changes Made in Senior Design 2 .....	90
6.3 Relevant Circuit Design .....	91
6.4 Graphical User Interface (GUI) .....	94
6.5 Fabrication .....	96
6.6 Future Development .....	97
7.0 Project Construction & Coding .....	100
7.1 Battery Selection .....	100
7.1.1 Changes Made in Senior Design 2 .....	102
7.2 Receiver & Transmitter Design .....	103
7.3 Circuit Design .....	104
7.4 PCB Schematics & Design .....	105
7.4.1 Changes Made in Senior Design 2 .....	110
7.5 Casing Fabrication .....	112
7.6 Software & Coding .....	114
8.0 Testing & Troubleshooting .....	117

8.1 Arduino Uno.....	117
8.2 Raspberry Pi .....	118
8.3 Temperature Sensor.....	118
8.4 Heart Rate Sensor & Respiratory Rate Sensor.....	119
8.5 GPS Module .....	121
8.6 Receiver & Transmitter Module .....	121
8.7 Testing Conclusions .....	122
9.0 Administrative Section.....	124
9.1 Planning Process .....	124
9.2 Cost Analysis .....	124
9.2.1 Changes Made in Senior Design 2 .....	126
9.3 Milestones .....	126
10.0 Conclusion .....	128
11.0 Appendices.....	129
11.1 Bibliography.....	129
11.2 Permissions.....	130

## List of Figures

Figure 1: Firefighters & Equipment.....	4
Figure 2: Military & Equipment .....	5
Figure 3: Police & Equipment .....	6
Figure 4: EMTs & Equipment .....	7
Figure 5: Possible design ideas.....	9
Figure 6: Body Diagram & Workload .....	11
Figure 7: Individual top 5 ideas .....	13
Figure 8: Narrowing down ideas.....	13
Figure 9: House of Quality Diagram .....	16
Figure 10: Raspberry Pi 3 .....	21
Figure 11: BeagleBone Black .....	22
Figure 12: NodeMCU .....	24
Figure 13: Teensy 3.6 .....	25
Figure 14: MSP430 Launchpad .....	26
Figure 15: STM32'The blue pill' .....	27
Figure 16: PocketBeagle.....	28
Figure 17: Arduino Uno R3 .....	29
Figure 18: Arduino Nano.....	30
Figure 19: Arduino Mega 2560.....	30
Figure 20: MySignals Board.....	34
Figure 21: BITalino (r)evolution Board.....	35
Figure 22: MAXREFDES100.....	36
Figure 23: Olimex Medical Series Board .....	37
Figure 24: TWR-MCF51MM Board .....	37
Figure 25: BMD101 Chip.....	38
Figure 26: AD8232 Chip .....	39
Figure 27: Raspberry Pi Heartrate/Pulse Sensor.....	40
Figure 28: DS18B20 Digital Temperature Sensors .....	41
Figure 29: MCP9808 High Accuracy I2C Temperature Sensor Breakout Board .....	41
Figure 30: SparkFun GPS Module Copernicus II DIP .....	44
Figure 31: SparkFun Venus GPS.....	45
Figure 32: EM-506 GPS Receiver .....	45
Figure 33: NEO-6M GPS Module .....	46
Figure 34: SMAKN® 315 MHz RF Transmitter and Receiver link kit .....	51
Figure 35: APC220 Wireless RF Modules .....	52
Figure 36: Solu CC1101 Wireless Transceiver Module.....	53
Figure 37: SMAKN® 433Mhz Rf Transmitter and Receiver Link Kit.....	54
Figure 38: Refaxi 2 Set 433Mhz RF Receiver Transmitter Module.....	55
Figure 39: nRF24L01+ 2.4GHz Wireless Transceiver .....	57
Figure 40: Superbat 433Mhz 3dBi Rubber Duck Antenna SMA Male for Ham Radio....	60
Figure 41: IP-65 Rated Outdoor 868 & 915 MHz Antenna with SMA Male Connector..	61
Figure 42: 1PC 433Mhz 3dbi Omni Antenna SMA Male Straight Duck Aerial FPVRC .	62
Figure 43: 15Mhz 433Mhz 470Mhz Antenna 15dbi O-mini With Sma Male Connector.	63
Figure 44: MS5607 Altimeter Module .....	67
Figure 45: Finalized GUI.....	70

Figure 46: Raspberry Pi ADC Chip .....	71
Figure 47: GPS Embedded Antenna SMA .....	71
Figure 48: Raspberry Pi 433MHz Transmitter & Receiver .....	72
Figure 49: Raspberry Pi 2.4GHz NRF24L01+ Module Transmitter/Receiver .....	73
Figure 50: Core Components of M-GU4RD .....	74
Figure 51: Software Test Process Model .....	83
Figure 52: MCU Software & Language.....	85
Figure 53: Finalized PCB Design .....	91
Figure 54: Voltage Divider .....	92
Figure 55: Operational Amplifier .....	92
Figure 56: Switching.....	93
Figure 57: Linear.....	94
Figure 58: Possible GUI display .....	95
Figure 59: Ideal designs .....	96
Figure 60: Tx High Level Diagram .....	103
Figure 61: Option 1 .....	104
Figure 62: Option 2.....	104
Figure 63: Arduino Circuit.....	107
Figure 64: Raspberry Pi Circuit .....	108
Figure 65: Safety Circuit.....	109
Figure 66: Overall Schematic .....	110
Figure 67: Finalized Overall Schematic .....	111
Figure 68: Charging Circuit Schematic .....	111
Figure 69: Buck Converter Circuit Schematic.....	111
Figure 70: Casing Dimensions.....	112
Figure 71: Casing side view.....	113
Figure 72: Data Modeling.....	114
Figure 73: State Machine Diagram.....	116
Figure 74: Electrode Placement.....	120
Figure 75: RF Setup.....	122
Figure 76: Breadboard Testing .....	123
Figure 77: Milestone Tracking.....	124

## List of Tables

Table 1: Microprocessor Comparison.....	22
Table 2: Microcontroller Comparison .....	31
Table 3: DS18B20 and MCP9808 .....	42
Table 4: MCP9808 vs DS18B20 additional notes .....	42
Table 5: GPS Module Comparison.....	47
Table 6: VSWR and Reflection Coefficient .....	59
Table 7: Selection of RF Module Comparison table .....	65
Table 8: Core Components of M-GU4RD.....	74
Table 9: GUI color indicators .....	96
Table 10: Power Supply.....	100
Table 11: Battery Selection.....	102
Table 12: Arduino Schematic Components .....	107
Table 13: Raspberry Pi Schematic Components.....	109
Table 14: Hardware Dimensions for main Components.....	113
Table 15: Predicted Component Costs.....	125
Table 16: Actual Component Costs .....	125
Table 17: Total Unit Cost .....	126
Table 18: Total Development Costs .....	126
Table 19: Due Dates.....	127

# 1.0 Executive Summary

Every day, millions of members of military and first-responders report for duty. These distinguished men and women put the welfare of the people first by putting themselves at the forefront of danger. Military men, police officers, firefighters, and EMTs establish order amongst the chaos and ensure the survival of the everyday citizen. Through gunfire, flames, and even death these first-responders endure knowing their days may be numbered. With all the dangers and hazards these people face, it is important to provide them with anything and everything necessary to raise their chances of survival and those who are rescued by them. Ensuring the well-being of these brave professionals should be of utmost priority.

The “Golden Hour” is often used to describe the hour after receiving a traumatic injury in which one would need medical attention. During this time it is important to rescue and stabilize the injured in order to increase their survivability. If medical treatment is not given, the injured will be under extreme stress. This can include massive blood loss, internal rupturing, and loss of consciousness. Once this hour is up, medical treatment may be impossible and injuries sustained may affect a person’s life forever if they are not already dead.

The goal of this project is to construct a device to reduce casualties and monitor those who may be under extreme trauma or stress. This applies especially to those during the “Golden Hour”. The device made by the team will be used primarily for military and first-responders so that they can be constantly monitored from the outside. This will ensure that everyone going into the field is fully accounted for and later safely extracted from impending dangers.

The device, codenamed M-GU4RD, consists of two devices. One is the M-GU4RD itself which will be formed to the body via a vest or band. The other is a peripheral device or display. The display houses an application that can be connected to several M-GU4RDs and displays vitals, location, and other pertinent information of the person using it. The M-GU4RD device attached to the body has several electrodes to detect heart-rate, respiratory rate, and body temperature with an accompanying GPS to monitor the user’s location. This design is meant to be the barebones version of the M-GU4RD as the ideal version would be customizable and even specific to each profession. Future developments can include gas sensors and the addition of other biometric sensors.

In terms of hardware, the M-GU4RD prototype will be constructed using basic microcontrollers (Arduino Uno) and microprocessors (Raspberry Pi 3) integrated with biometric sensors and a GPS unit. All sensors and units are directly compatible with the MCUs/MPUs and will be attached seamlessly to them. A PCB will be made to distribute power to all electronic devices as needed. The peripheral device that displays information will house a GUI constructed by the team that can be accessed via an app.

While similar devices to the M-GU4RD exist in some capacity or another, the team hopes to design a more intensive and comprehensive device. The current devices under



development, especially in the medical field exist as large machines focused on monitoring patients. With advancements in technology, even select applications on smart watches can monitor certain vitals and obtain GPS location. Perhaps the closest designs to the M-GU4RD itself is the many fitness/trainer watches and body wear technology that help monitor vitals and other information to keep track of health and progress. These devices are more for commercial and public use for the everyday citizen. With this comes many constraints and standards that must be met for commercial sale. This can inhibit the overall performance and quality of the device. For the M-GU4RD the team wants to place value on multipurpose use and customization for those in professional careers, accuracy, an ergonomic fit, and affordability. The large problem with direct competitors to the M-GU4RD is the fact that their devices are astoundingly expensive and inflexible to a point where using their technology becomes more of a liability. That is why currently you do not see many police officers or firefighters wearing any form of monitoring device. The M-GU4RD will address this issue and keep these men safe.

## 2.0 Introduction

As firefighter and first-responder fatalities continue to remain high within recent years, new technologies are being researched and developed in effort to diminish these numbers. According to the U.S Fire Administration, in 2017 there were 58 line-in-duty deaths due to cardiac or physiological stress. To help prevent these incidents, tech companies are in the process of developing devices and new equipment to help first-responders monitor one another during duty. However, because of budget constraints and the high cost of these new technologies, not many first-responders can afford this equipment.

In an effort to help prevent unnecessary fatalities, this design presents an alternative to report the health of firefighters and first responders while responding to a call. This device will feature the capabilities to provide real time data regarding the health of each responder while on duty by recording vitals and GPS location of those on duty, as well as the presence of CO<sub>2</sub> and other possible gasses in the air. These multiple features will improve not only the efficiency of the first responders while on duty but it will also help them save themselves, so they can continue to serve and help protect others.

Our medical GPS unit for active response duty, M-GU4RD for short, will address all the concerns first-responders and those on active duty have. This device will fit around the body in a small and resistant portable housing that monitors all vitals and collects information regarding the current situation in order to manage and keep people safe within the field. This information will be sent to a Graphical Unit Interface (GUI), this interface will show the multiple vitals and location of the first responder to easily monitor them while on duty.

As stated prior the “Golden Hour” is the primary focus of our device. If the M-GU4RD could reduce the number of those who passed during that vital hour it will be successful. This primarily applies to those being rescued after being injured or to those directly in the line of fire. That aside a surprising number of first responders are also lost to suicide. Long term use of this device throughout the day can also reduce stressors that may result in suicidal thoughts and tendencies. Monitoring first responders directly after being in active duty can save lives.

This introduction focuses on the many careers the M-GU4RD can be applicable to, including but not limited to firefighters, military, police, and medical practitioners. The team will dive into these fields and analyze the current equipment they use and the situations they face. In addition the team will integrate proposed designs for an M-GU4RD that will be used in these situations. The M-GU4RD is supposed to be a flexible design with many applications that can be altered and adjusted depending on the situation. Analyzing the perspectives of those in different career paths, the team will analyze the best approach for such a device.

## 2.1 Firefighter Application



*Figure 1: Firefighters & Equipment*

As mentioned before there are already some devices and technology in development to monitor the vitals of the Firefighters on duty. The cost of this devices make them not accessible to the average department. This project will present a most cost effective design to allow all Firefighters departments have access to this technology.

The device will record and monitor the firefighter's vitals to ensure all are in safe physical conditions. Another key feature to this device will be a GPS signal to help monitor location. This feature will be most beneficial in cases of rescue. If a firefighter begins to have health issues or needs help escaping a dangerous area, a GPS location will help the other firefighters locate and capture in a time-efficient manner. In addition to these capabilities, this device will also include a built-in CO<sub>2</sub> sensor. The CO<sub>2</sub> sensor will constantly monitor the air for CO<sub>2</sub> presence which is mainly caused by leakages. Although there are many observable signs to the naked eye to alert the presence of CO<sub>2</sub>, a sensor that constantly gives reading of this substance will alert and help the Firefighter to take the appropriate steps to avoid any further catastrophe.

All these collected data will be send wireless to personnel outside. This person will have some sort of Graphical Unit Interface (GUI) to read the data and alert the Firefighters if any measure needs to be taken. In this situation this device would have to be small, durable, and fireproof. Firefighters carry a variety of heavy equipment and since they deal with fire they expend a lot of energy working through the heat so being lightweight is a must to reduce the stress on these first-responders.

Further enhancements to this device would include adding more biometric sensors which can be placed on the body preferably on the wrist and it would be unique if a peripheral device or sensor could be added that can detect temperature. This temperature sensor would be unique as it would be able to differentiate body heat from the ongoing fires. This information can then be sent to a person using the GUI who may be able to view the heat signatures or even alert the firefighter themselves in order to find survivors and get them and the firefighter out as soon as possible. It would be even better if all this could be incorporated into a firefighter's visor.

## 2.2 Military Application



*Figure 2: Military & Equipment*

There is already similar technology that military have access to and with plenty of funding and secrecy there is no telling how advanced their gear and methods are, especially for those in the special forces. One primary concern that veterans often express after leaving the field is not having the ability to quickly respond to squad members that may be injured, MIA, or KIA. This is a growing issue as war can get chaotic and you can lose track of your squad mates. Under these conditions every second counts and if someone is injured and distant from his members if no one is there on time they could bleed out. This device will be used to save people before this can happen.

If our team were to focus this design on military use it would be best to incorporate a large, flexible, durable, and lightweight touchscreen display. Ideally this technology would be best if it could remain compact and worn on the wrist. This may not be possible due to the bulk of a large screen and a variety of extra features specific to reconnaissance and combat. If that remains a problem the technology can be used more as a carry-on device.

Out in the field, armed forces need to communicate but also remain stealthy. The touch screen will display vitals of all squad members including their own. GPS will also be incorporated with the display to show locations of friendlies and even marked enemies.

Since there is a touchscreen, commanders can take charge and draw attack patterns on the screen to communicate with his squad. All this can be done without a single word to remain hidden from the enemy.

If an ally is injured or needs assistance they can send a signal on their device. This will reduce casualties and improve safety. If an ally is to be captured or killed, safety precautions would need to be made in order to prevent information on this device from being accessed by the enemy. In the case of being captured the device can be manually locked or even fried rendering it useless. If killed, the device would read until vitals drop to zero, indicating death and then either lock or self-destruct.

### 2.3 Police Application



*Figure 3: Police & Equipment*

As we have seen in many other areas of the public sector, some new technologies are being implemented to make the job of these workers much easier and safe. An average office carries a bullet proof vest, a gun with about 30 rounds of ammo, a flashlight, a baton, a two-way radio and handcuffs, and some already have implemented a micro body-camera that goes for about \$130 or more. Nowadays, with the rapidly growing and evolving technologies it is much easier and feasible to implement these devices into their already worn uniforms or required gear.

If we were to implement this design to the police enforcement application, it will not only benefit the officers on duty and their health but also the police community as a whole. Due to recent events there might be some political conflicts in relation to determine if the officer



is mentally fit for duty. This device will then have not only the medical capabilities but also psychological capabilities.

In this scenario, we will focus on applying the same principles as the other applications such as for the medical benefit of the officers. They will include reading and sending vitals, GPS location and detecting CO2 or other gases in presence. In addition to these, we would also like to include Physiological and Sociometric sensors to detect and measure the officer's levels of stress and mental fatigue; and by doing so preventing trigger-happy casualties or any future physiological and mental illness.

In further development these devices can even be used as identification. With the growing issue of police brutality, this device can act as a key to unlock weapons designated to certain officers or even lock weapons if their vitals are off. Aside from this mechanism, it would be nice if this device ran similarly to the one specified for military application. Since both involve combat and firearms the danger is immense so having a device with a full display where you can communicate with squad members, plan an approach, and execute on it would be necessary. This would be more preferable to police specialists and SWAT team members.

## 2.4 Medical Application



*Figure 4: EMTs & Equipment*

The medical industry already utilizes technology similar to this project idea that helps to monitor patients' health remotely. There are several companies that work toward allowing hospitals to keep track of different health variables of the patients while they are at home.

Some aspects that are considered with these products are blood pressure, sleep, weight, and vitals. Honeywell has a device called the Genesis Touch that collects biometrics from the patient and even offers video visits.

The main motive for these devices is to monitor the health of a patient that has a chronic disease, in which case it would be too expensive to keep the patient in a hospital.

This project could probably be applied to the hospital setting in a different way from these existing devices. The device would gather important information regarding the patients' health using sensors. The offices within the hospitals would have access to all of this information and would be alerted if any patient's vitals go under or over safe conditions. These alerts could also be adjusted for different people if certain conditions necessitate different levels for safety of the patient.

The device would not only assist in monitoring patients in real time, but also serve as a way to collect data. This may be important for advancement of knowledge pertaining to diseases and illnesses that lack research and understanding on.

### 3.0 Project Description & Design Ideas

This section contains the discussion of the ideas pre-development and pre-implementation as well as the project selection, design, description, efficacy, motivation and goals projected for M-GU4RD.



*Figure 5: Possible design ideas*

In order to monitor first responders when they are out in the field and ensure they are safe our team is designing a device that reports/shares vitals and other pertinent information amongst those involved. Ideally this device would be ergonomic in design as to not be intrusive to the user. It would also include an interactive display capable of showing the location of squad members and their status. With this design we can incorporate non-verbal communication using the touchscreen to mark hazards, draw paths of approach, etcetera. While this is the ideal design it is not the most practical. Firefighters and military personnel have similar technology available to them already, but these devices are incredibly expensive and because of the price they see very little use. Our focus is to create a more innovative device one that is more compact, affordable, and overall very efficient.

To compete with present devices our device will not include a display. Instead, all vitals and info will report to a leading official. A GPS unit will be used to track first responders and there will be a multipurpose button that can be used as a panic/help button. All this information will report to a central computer with software that monitors everyone involved. This technology should be used in tandem with some form of communication so that the official receiving this information can call shots and provide support. Vitals will primarily focus on heart rate and oxygen percentage, but depending on the devices use more vitals can be added with various attachments to fit the need of the user.

As stated prior, this kind of device has several applications useful for military officials, firefighters, medical practitioners, and law enforcement. While our team intends to create a device that can cater to all these professions with various attachments our design will focus strictly on the basics of recording vitals and sending other pertinent information.



### 3.1 Research of existing Projects and Products

Nowadays with technology moving at a very fast phase. Many of the development and research that is implemented into new technologies overlap and sometimes evolves from one design to another. As is the case of the medical industry, technology tends to move a bit slower since there are not many technological companies dedicated to this industry. However, there are some that really try to implement and adopt the latest software and hardware tools to better this industry. Next we present two technologies that are existing or in current development that match our project idea:

1. “MySignals” is one of the technology developed as a platform to incorporate medical devices and eHealth applications. MySignals includes more than 15 different biometric parameters such as Temperature, Glucometer, ECG, EMG, Blood Pressure, etc. MySignals was developed for medical use in Hospitals or clinics for a more integrated way to read data with a very easy-to-use and mobile device. Furthermore, MySignals can adapt to almost any medical sensor out there and they are working on developing more every year, and now they offer a cloud based technology for data storage and delivery. However, since there are not many competitors in the health industry, as previously mentioned, the prices for these boards and platforms are very expensive ranging from \$1,000 to \$1,900 dollars.
2. “BodyTrak” is another technology currently under development and with very promising results. The BodyTrak platform utilizes real-time data analytics and machine learning to automate and get precise reading from where most vital signs can be measured, the ear. This non-invasive, in-ear device can obtain key vital sign parameters in real time and sends them to a cloud-based analytics platform. The device also serves as a two-way radio communication device and ambient sound transparency, which according to BodyTrak are essential for health and safety applications. Furthermore, BodyTrak offers its cloud-based applications, an extended list of sensor capability, voice prompts and communication system integration. However, since this is one of the only devices available in the market and under development the prices, as we have seen with the MySignals platform, can get sky rocketed very easily.

As we can observe there are very few products in the market that are similar to M-GU4RD or have some similarities at all. The MySignals is more of a platform for very extended medical products exclusively and hence it is very expensive to obtain. On the other hand, BodyTrak has a lot more similarities to M-GU4RD, many of the capabilities of both overlap. However, the main purpose of M-GU4RD is that it will be a low-cost medical tracking solution for first responders and low-budget government or private organizations that may want to adhere M-GU4RD for the safekeeping of their employees.

Here is where the challenge of the group comes, since the technology is already available the goal of this group will be to implement this technology giving a much easier to implement design in effort to also reduce the price of the design.

## 3.2 Functional Block Diagram

The diagram above represents the multiple components of this design as well as the possible candidates in charge of their functionality. These candidates were chosen according to their strengths and background, some of these strengths included Coding Integration, RF Communications, Circuit Design theory and Software Development experience.

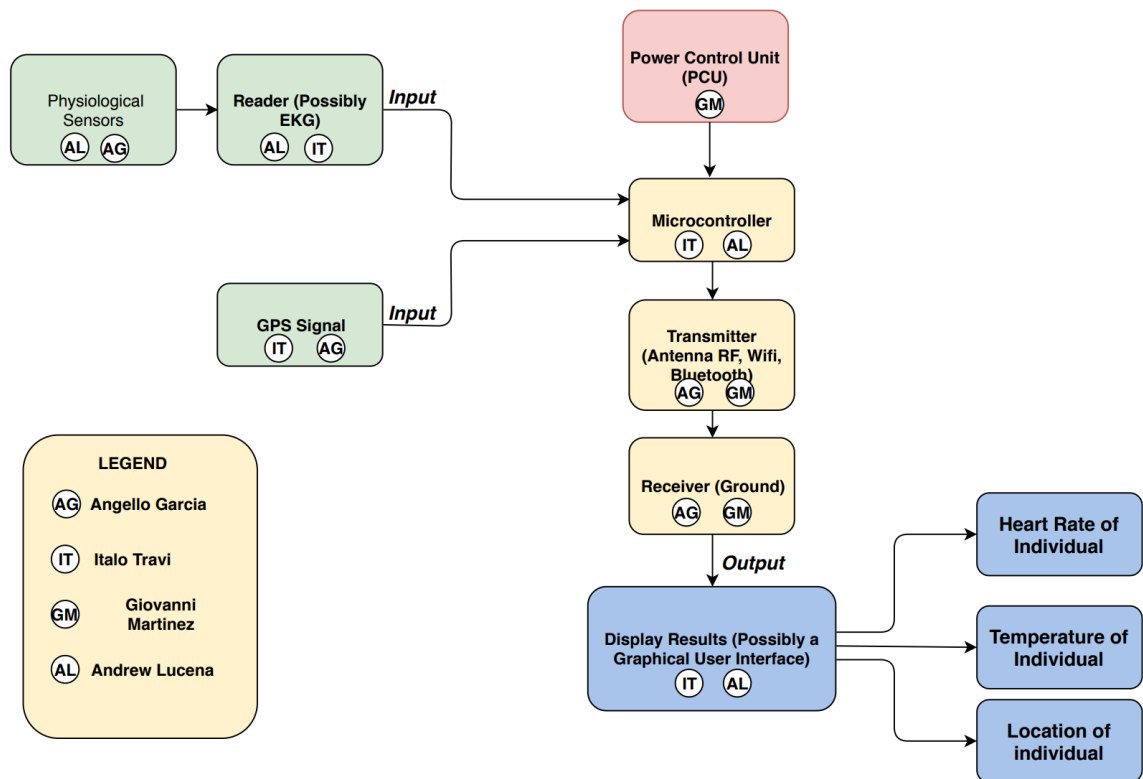

*Figure 6: Body Diagram & Workload*

The design has three different inputs:

The first input is obtained by using sensors to read vitals. The physiological sensors will take the vitals and send them to a reader (possibly EKG). The candidates for this task are Andrew Lucena (Electrical Engineer) due to his background working with sensors, and Angello Garcia (Electrical Engineer). Andrew and Angello along with Italo Travi (Computer Engineer) will work as a team to get the readings of the vitals.

The second input will be the CO2 sensor. This sensor will be worked on by Giovanni Martinez (Electrical Engineer) and Andrew Lucena.

The third input is the GPS signal and will be tasked to Italo Travi and Angello Garcia, utilizing Angello's background and career focus in RF Communications.

The three inputs will be sent to the Microcontroller which will process the information. This task will be performed by Italo Travi due to his coding background. The Power Control Unit will be designed by Giovanni Martinez utilizing his background in Circuit Design. The Microcontroller and PCU will be mounted on the Printer Circuit Board (PCB) designed by the three Electrical Engineers. Furthermore, the information obtained will be sent to a receiver; this task will be held by Angello Garcia and Giovanni Martinez. The receiver will show the results on a screen (possibly a Graphical Unit Interface) and these results will include the vital signs, GPS location and CO<sub>2</sub> levels. The two people in charge of this task will be Andrew Lucena and Italo Travi due to their coding experience.

### **3.3 Objective/Goals**

Our primary objective is to create a monitoring device for first-responders capable of displaying and sending vitals to a leading official to keep people safe. This technology should be used in tandem with a communication device, but should also be useful as a standalone communication system if the case arises. Since similar tech exists, our team is aiming to provide on their shortcomings. The competing devices used for firefighters, military, and EMTs are either broken up into several components or are too expensive to be used in the field. Our goal is to condense that technology into one wearable device, reduce the cost, and add further features such as CO<sub>2</sub> detection, in the case of firefighters. The circuitry of the device would also need to be covered in a durable material.

Another problem is wear-ability. Ideally it would be best on the wrist as it would not interfere with the wearer, but if an EKG is used to take vitals the device would be more of an accessory and would have to be equipped elsewhere. Firefighters for example wear a large suit that covers the entire body so incorporating a display on a wrist device to check their own vitals is not feasible. That being said the component selected to take vitals would determine where on the body the technology will be placed.

Future goals would be able to further enhance the features stated with additional health stats and other useful peripheral features. It would also be nice to integrate this design into other safety related careers.

### **3.4 Brainstorming**

Our team had frequent meetings over the course of several weeks. During these sessions each member would present a new idea to address a specific problem. Ideas were bounced off one another where things were added, reinforced, taken out, and redone. Each new problem presented more intuitive thinking and our group would decide on a vast selection of solutions. Many ideas involved monitoring devices to ensure safety. Others involved novelties such as gloves that took measurements and language translation devices. Even bike accessories were considered. These discussion sessions had no limitations and all ideas were considered, even if used as stepping stones to get to greater ideas.

The table below shows the top 12 different project ideas that were pre-screened and narrowed down from another 30 ideas. After analyzing and giving each member of the

group the opportunity to research and select their top five favorite ideas to work on, the following table was created.

Top Projects to choose				
Project Title	Andrew	Angello	Italo	Giovanni
Firefighter Life Monitor	<input checked="" type="checkbox"/>	<input checked="" type="checkbox"/>	<input checked="" type="checkbox"/>	<input checked="" type="checkbox"/>
Smart eyes for blind	<input checked="" type="checkbox"/>	<input checked="" type="checkbox"/>	<input checked="" type="checkbox"/>	<input checked="" type="checkbox"/>
Measuring gloves	<input checked="" type="checkbox"/>	<input checked="" type="checkbox"/>	<input checked="" type="checkbox"/>	<input checked="" type="checkbox"/>
Monitor/Alarm patch	<input checked="" type="checkbox"/>	<input checked="" type="checkbox"/>	<input checked="" type="checkbox"/>	<input checked="" type="checkbox"/>
Smart pool babyseater	<input type="checkbox"/>	<input type="checkbox"/>	<input checked="" type="checkbox"/>	<input type="checkbox"/>
Smart driving assistant	<input type="checkbox"/>	<input checked="" type="checkbox"/>	<input type="checkbox"/>	<input type="checkbox"/>
Portable breathalyzer	<input type="checkbox"/>	<input type="checkbox"/>	<input type="checkbox"/>	<input type="checkbox"/>
Moving assistant	<input type="checkbox"/>	<input type="checkbox"/>	<input type="checkbox"/>	<input type="checkbox"/>
Stutter device	<input type="checkbox"/>	<input type="checkbox"/>	<input type="checkbox"/>	<input type="checkbox"/>
Translating device	<input checked="" type="checkbox"/>	<input type="checkbox"/>	<input type="checkbox"/>	<input type="checkbox"/>
Self-assembling goal	<input type="checkbox"/>	<input type="checkbox"/>	<input type="checkbox"/>	<input checked="" type="checkbox"/>
Signal booster antenna	<input type="checkbox"/>	<input type="checkbox"/>	<input type="checkbox"/>	<input type="checkbox"/>

Figure 7: Individual top 5 ideas

TOP 4 Projects	Work analysis	Cost analysis	Time analysis	Resources analysis	Team distribution	Polished Turd?	TOTAL COST
Firefighter Life Monitor	3	3	3	1	1	1	12
Smart eyes for blind	2	3	3	1	2	2	13
Measuring gloves	2	2	2	1	3	3	13
Monitor/Alarm patch	2	2	1	1	3	3	12
<b>Winners</b>							
Firefighter Life Monitor	1						
Smart eyes for blind	2						
Monitor/Alarm patch	3						
Measuring gloves	4						

Figure 8: Narrowing down ideas

In the end, our group solidified a list of ten strong project ideas. Among this list consisted of security/alarm systems, the as stated prior measurement gloves, and the prerequisite to the M-GU4RD. Each group member selected their top three design ideas which was condensed further into the top three for the group as a whole. With our top three ideas selected we created a system involving number grades from 1 to 3 (1 being ideal and 3

being not ideal). The team then rated each idea in several categories including cost and difficulty. The design with the lowest score at the end would be the ideal choice. After reaffirming that the M-GU4RD was our best option we again took a vote where we unanimously decided on the M-GU4RD.

### **3.5 Motivation**

Our team wanted to make something impactful that could revolutionize everyday life. Something that could help with real problems and even save people. While brainstorming and researching ideas we looked into solving problems such as school/police shootings, children drowning, and aiding the disabled. These problems resulted in ideas for monitoring devices, alarm systems, and visual aids. While discussing these ideas we always came back to the same one.

The design our team kept coming back to was a monitoring device for first responders. Many of the designs that were discussed during our brainstorming sessions involved wrist devices with monitoring capabilities anyways and we felt that this device was the most practical. The question then became: “Does this already exist?” and “Who would use this technology?” While similar technology existed it took many forms and incorporated several devices. Our team wanted to condense it down and lower the cost. When discussing who this technology is for it was natural to think firefighters. Our group consisted of relatives and friends of firefighters, military men, and medical practitioners believing that providing them with safety is a noble cause.

Although this design is focused on first-responders our team hopes to create a flexible design that can be used for other career paths including the military and police officers. Our team is treating this design process as a learning experience in hopes that our project aids in landing a job. If the project is above and beyond successful it can even be developed further.

### **3.6 Functional Requirements**

- Must be less than 20 centimeters wide
- Must be less than 20 centimeters long
- Must be less than 15 centimeters thick
- Will be able to take vital signs such as respiratory rate
- Will be able to take vital signs such as hear rate
- Will be able to take vital signs such as Body temperature
- Must weigh less than 7.5 pounds
- Must be able to operate for at least two hours
- Must have a set up time of less than one minute
- Must have a range of transmission of at least 50 meters radius
- The transmitter shall be consisted of ECG, Temperature Sensor, GPS and RF Module, battery
- The receiver shall have a graphical interface
- The Graphical Interface shall display the sensors data

- The Power Supply shall be able to power both microcontrollers and multiple sensors
- The temperature sensor should be within 5 degrees Fahrenheit accuracy
- The Battery shall not weight more than 2 pounds
- The Battery shall be removable from the housing
- The casing shall hold the microcontroller, microprocessor, GPS and RF Module and ECG Shield
- The casing should resist at least 70 degrees Celsius
- The GPS shall have a refresh rate of at least one hertz
- The RF module shall transmit 2400 bps air data transfer
- The ECG shall fall under HIPAA standards
- The Microcontroller shall be able to handle the vitals sensors
- The Microprocessor shall be able to interface with the Microcontroller
- The GPS shall use at least 10 different channels
- The Microprocessor shall be able to connect to the RF Module to transmit wireless data
- The Graphical Unit Interface shall be able to connect to the RF Receiver to display the data
- The system shall be able to regulate different voltages
- The system shall be able to operate under FCC regulations
- The system shall have an ergonomic
- The battery shall be rechargeable
- The wireless receiver shall be able to attach to a laptop or tablet
- The system shall be to withstand a fall from one meter
- The circuitry within the casing shall be accessible to users
- Must be able to transmit an accurate GPS location point
- The system shall have room for future developments such as additional sensors
- Must be able to transmit information wirelessly to a centralized unit
- Must be able to alert if any readings are not normal
- Must follow regulatory laws for the communication spectrum
- Must cost less than \$400 to build
- Must have a windows type applications for the GUI

### **3.7 House of Quality**

The House of Quality diagram above demonstrates the correlations between the marketing requirements and the engineering requirements as well as the correlation between the different engineering requirements. The engineering requirements under analysis are weight, cost, power lifetime, dimensions, accuracy, and install time. The size, cost, durability, portability, low power, and quality are the marketing requirements that are focused on. The “up” arrows indicate that the two requirements have a positive correlation while the “down” arrow indicates the two requirements have a negative correlation. The double arrows indicate that the correlation is strong while the single arrow is indicative of a moderate correlation. Also listed are the specific values for the engineering requirements of this project.

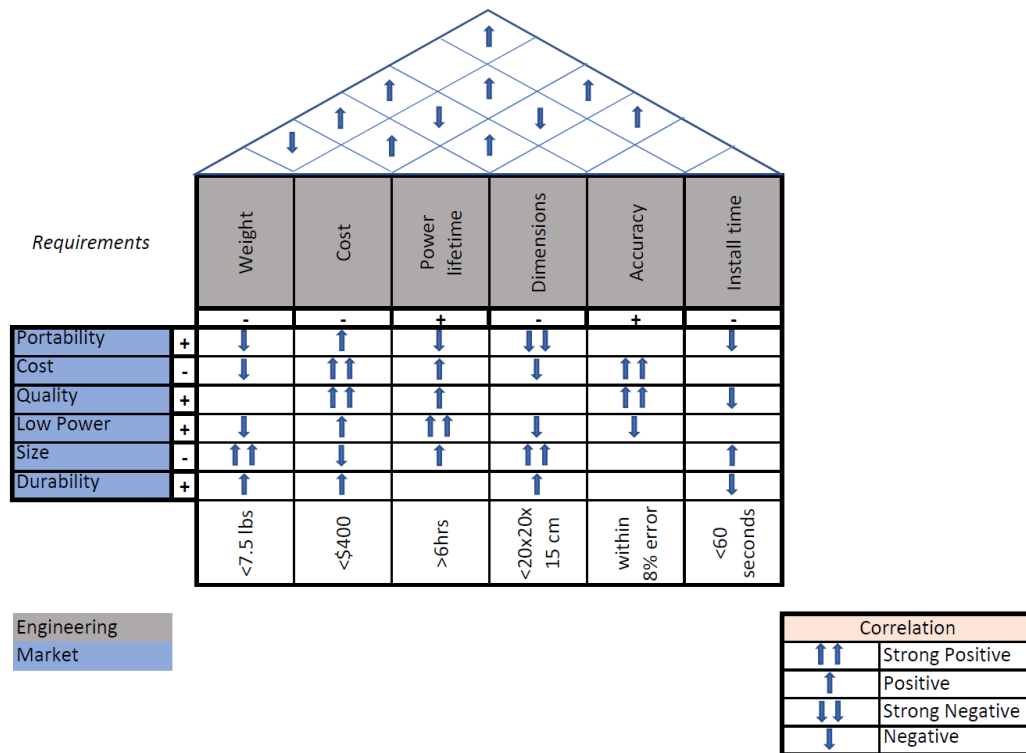

Figure 9: House of Quality Diagram

### 3.8 Demonstrable Requirements

One of the demonstrable requirements will be the Power Source Unit of the device. The way this will be presented would be through a short time-lapse video showing the battery capacitance vs time, in which we will be able to see the minimum of six hours of battery life in one run of charge.

Another demonstrable requirement will be the integrated GPS system, which will send live feedback from the wearable device into a temporary or finalized receiver that will interpret and show these signals in the GUI representation display.

Ultimately, another possible requirement will be the Heart Rate Monitor, which will read and interpret the signals for heart rate and with the help of the micro-controller send these signals to the GUI display for each specific device UID. Hereby accomplishing some of the main functional requirements according to the engineering design specifications.

### **3.8.1 Changes Made in Senior Design 2**

Some alterations were made to what will be the three demonstrable requirements for the M-GU4RD. As the device neared its completion the team decided the best three demonstratables for the device will be its wireless communication range, its GPS capabilities, and its ability to collect data from the heart rate, respiration rate, and temperature sensors. A video will be made to demonstrate the accuracy of the GPS location of the M-GU4RD. Another video will be shown demonstrating the range capabilities of the wireless communication between the device and a receiver connected to a GUI. The sensor demonstration will be done in person at the final presentation showing the sensor data gathering.

### **3.9 Problems Encountered**

Originally our design existed in limbo, to a point where the team was indecisive on its application. While our group was set on the idea of creating a device that could monitor various people in different professions. There was confusion on whether it would be better to focus our design specifically on either military or firefighters. After much debate we settled on firefighters, but later we went back to keeping it ambiguous to maintain a flexible design. During the time when our design was focused on firefighters, the idea of an interactive display was dropped as firefighters would not be able to use it due to their large suits. Along the way the design itself caused confusion among the group. The majority of the team was under the impression that our design would be wrist mounted, but accurate sensors and an EKG would lead to a bulkier design that would have to be worn elsewhere on the body. While the team is still aiming to create a device as small as possible we are open to all wearing possibilities.

The primary problem the team faced was being under a heavy time constraint. Finding the right parts that function together the right way took large amounts of time in research. In addition most of the components involved in creating the M-GU4RD had to be shipped from overseas which stalled all testing and further development of the device. There was also no guarantee that the parts would work together in actual application, although theoretically they should. Understanding all the components, their uses and features, as well as their schematics involving inputs and outputs took time. Interfacing all the components involved multiple circuit construction and knowledge of the device itself. There is also a learning curve as the team had to create safety circuits and distribute voltage and current properly to each device. On the software end, code had to be adjusted to fit the teams testing parameters. Some sensors were even having accuracy issues that needed to be adjusted, if not working altogether.

Another issue revolved around planning. While designing the M-GU4RD the team had to prioritize their time to make ends meet. The majority of the group members had many family obligations while also being full-time students. Each member was heavily involved in school activities and clubs. Some of the group members even had full-time jobs, if not,



they were constantly looking for employment in the next few months due to graduation running near.

This also played a role in funding as the entire project was self-funded. The main point of the M-GU4RD was to keep a sleek, accurate, and helpful device that can address costs of its competitors and can be used among actual first-responders. Due to the self funding the team was only capable of making a useful device similar to its competitors, but not entirely standing on its own. With more cash flow the design can be narrowed down and made even better with more options and sensors.

## 4.0 Research & Part Selection

For this project research is done to process and develop a unique device meant to monitor those in dangerous situations. Our team calls this device project M-GU4RD.

This section includes all the research done into selecting the parts for the original M-GU4RD. This includes microprocessors/microcontrollers, biometric sensors, GPS, and other necessary equipment. The team investigates varying hardware in order to select the most suited for the final device.

### 4.1 Microprocessor/Microcontroller Selection

With the advent of semiconductors, microprocessors and microcontrollers have become a large part of almost any electronic system. With Moore's Law, which states that every 18 months the size of the transistor is halved, integrated circuits have gotten smaller and smaller. The smaller size of these chips allow for powerful computing in very small devices. Microprocessors and microcontrollers benefit from this high computing power density and are used in basically every electronic appliance. There are slight differences between the two that make them useful for different applications, but are also quite similar.

A microprocessor is basically the central processing unit, or CPU. A microprocessor contains no RAM, ROM, or any other extra devices. This differs greatly from the microcontroller in that a microcontroller has RAM and ROM as well as the CPU. These differences effectively make the functions and applications for each device distinct. A microcontroller is designed to perform very specific duties, or outputs, given a set of inputs. Because these tasks are so narrow, the microcontroller does not need much RAM or ROM, which keeps the overall size small and compact for devices like microwaves, washing machines, and dryers. A microprocessor, on the other hand, is useful in performing jobs that are wide-ranged such as software and websites. The microprocessor has a higher clock speed and needs more RAM and ROM for its applications, so they are commonly found in computers, laptops, and tablets.

The purpose of looking into microcontrollers for the M-GU4RD is that it will be the device necessary to grab inputs from the sensors, such as vitals and GPS location, and output them accordingly. The microcontroller has the specific jobs tied directly to the data collected from the sensors. The function of the microprocessor in the M-GU4RD would be to relay the collected information to other platforms such as the GUI display that will be connected wirelessly.

The microcontroller/microprocessor of the M-GU4RD will serve as the backbone of the entire device. Selecting a development board means searching for compatible sensors and GPS units. Our board must meet these requirements:

- Must have some form of wireless communication (possibly over internet)
- Fast response time to keep accurate sensor readings
- Must be Programmable in C/C++, Java, or Python

- Plenty of input/output ports to support all the attachments from sensors to GPS

#### **4.1.1 Microprocessors**

This is the more robust option where the device contains a large amount of processing power and memory. Using a microprocessor is equivalent to running a small computer capable of accessing the internet. If the sensors and GPS utilized with the M-GU4RD require large memory space and processing power or a microcontroller lacks the amount of connections and support a microprocessor can be used. For the final design a microprocessor can be used either independently or in tandem with a microcontroller, especially since using a microprocessor requires an analog-to-digital convertor to translate sensor data.

#### **Raspberry Pi:**

This Microcomputer is one of the more popular development boards in production in addition to being one of the most affordable at \$35. The Raspberry Pi itself operates as one of the most compact computers capable of downloading and using software and even access the internet. The Raspberry Pi itself is more powerful than any microcontroller out there. Essentially with its capability to run multiple processes or programs at a time acting as a micro-computer with a SOC (System on Chip), this disqualifies the Raspberry Pi to be a Microcontroller since a Microcontroller is a single processing unit. However, the functionality and extensive research and development done on this specific microcomputer allows us to extend the capabilities of the project and implement many other as it broads our options for implementation and functionalities that are being done now and in future development for M-GU4RD.

The two possible options to go with for the Raspberry Pi:

The model 'Raspberry Pi 3 B' has built-in WiFi and bluetooth perfect for wireless communication. In terms of processing power, it has 1.2 GHz 64-bit quad-core ARM Cortex-A53 processor and 1GB RAM which is more than enough to store information on vitals and location. This power allows for fast and accurate response and readings to be sent to another device. It is also programmable in both Java and Python and consists of 40 GPIO pins which is more than enough pins for the biological sensors needed for the M-GU4RD and more. Additional specifications include 4 USB ports, an Ethernet port, and an HDMI port.

Meanwhile, the model 'Raspberry Pi 3 B+' has built-in WiFi and Bluetooth, a DUAL band wireless LAN, Bluetooth 4.2/BLE, faster Ethernet speeds and Power-over-Ethernet support with separate PoE HAT. This model also comes with a slightly faster processing power with a Broadcom ARMv8 64-bit Cortex-A53 processor that runs at 1.4GHz, 0.2 GHz faster than the model 3 B and with overclocking capability. It also supports 2.4GHz and 5GHz IEEE 802.11 b/g/n/ac wireless LAN as well as Bluetooth 4.2 with BLE, which are the main wireless communication technologies that we are considering for the project. This board is also equipped with 4 USB 2.0 ports and an extended 40-pin GPIO header, which will be

utilized for IO devices and sensors. The board is compatible with a Micro SD port for loading the operating system and the main advantage with the Raspberry Pi is that since it runs an ARMv8 chip, you can program it in many languages that are able to compile on that chip for example; Python, Java, JavaScript, C language, C++ and many other similar ones.

It would be beneficial to use either one of these boards as the team is already familiar in using it. In terms of M-GU4RD design, the Raspberry Pi would be excellent for making our own application for the graphical user interface (GUI). Its utility as a computer and access to the internet allows us to use the board as either a sending device or even a receiving device that may use the GUI. In addition, its programmability in Java and Python are excellent as the team is proficient in programming in these languages. The excessive amount of input/output pins provides more than enough connections for sensors and peripheral devices. This is enough to incorporate all biological sensors for the M-GU4RD and even add attachments in the future. Having many different input ports and communication mechanisms (USB, Ethernet, HDMI, Bluetooth, and Internet) will allow the team to test different communication methods that can communicate with an offhand device using the GUI. With programming capabilities supported in Java and Python and plenty of inputs for sensors the Raspberry Pi is an ideal choice for the M-GU4RD.

One concern for this board is whether or not the biological sensors the team needs will be compatible with it. If this continues to be a problem, the Arduino Uno would have to be used as a intermediary device for this and any microprocessor that will be used down the line as the Arduino Uno has a large support of compatible sensors.



*Figure 10: Raspberry Pi 3*

### **BeagleBone Black:**

This microprocessor is one of the top competitors that rivals even the Raspberry Pi. At \$45 it is still slightly more expensive than its competition, but unlike the Raspberry Pi it is usable straight from the box. The BeagleBone Black is still a relatively new device in the development board platform, but nonetheless it is just as powerful. With a 1GHz ARM Cortex processor, 512MB DDR3 RAM, and 4GB 8-bit eMMC on-board flash storage it has a similar design to the Raspberry Pi. In addition, this microprocessor contains 2x 46 pin headers with more GPIO pins than its competition. Extra features include: USB, Ethernet, and HDMI connectivity.

The BeagleBone Black carries a lot of processing power and connectivity choices, but it sacrifices in the audio and visual departments. This is not a main concern in our current design, but future enhancements in the M-GU4RD may need a platform with these capabilities. In addition to these developments, this microprocessor lacks the same support that helps the Raspberry Pi and Arduino flourish. Looking for compatible devices and sensors may prove to be an issue later down the line. The team itself is not overly familiar with this device so it will take some time to learn and understand. There is also the issue of software support. This microprocessor works well with Android and this would be a new venture for the team. As an alternative to the Raspberry Pi this device may serve as a replacement if any problems arise.



*Figure 11: BeagleBone Black*

Below is a comparison table between the two above microprocessors that the team found the most ideal to form the M-GU4RD and its peripheral device. The choice of which microprocessor to use is important as the team will need two that can wirelessly interact with one another. One will be attached to the physical M-GU4RD itself and the other to the peripheral device.

	Processor	Memory	Size	Cost
Raspberry Pi	700 MHz Low Power ARM1176JZ-F Applications Processor	512MB SDRAM	8.6cm x 5.4cm x 1.7cm	\$35
BeagleBone Black	1 GHz ARM Cortex-A8	512 MB DDR3	86.40 × 53.3 mm (3.402 × 2.10 in)	\$45

*Table 1: Microprocessor Comparison*

Legend	
	Chosen
	Not Acceptable

#### 4.1.2 Microcontrollers

Microcontrollers (MCU) are unique in comparison to microprocessors (MPU) as they lack the memory space and processing power of a computer. Instead, they specialize in analog device connection and support. This makes MCUs ideal for incorporating many different attachable functionalities and converting the data into the digital domain. Unlike MPUs, most MCUs have that analog-to-digital convertor. While the M-GU4RD may be able to handle everything on a microcontroller, using a microprocessor in tandem with it provides more space and flexibility for further design purposes.

##### NodeMCU:

This Microcontroller has been emerging and slowly becoming one of the developer's favorites for its very low cost, which comes to approximately less than \$10, and also because of the few extra features it has on board. Similarly, in size to the Arduino Nano but a lot more efficient and with a Wi-Fi card included. The NodeMCU also named ESP8266 is a very well supported platform and to differ from the Arduinos, it is not limited to the use of the Arduino IDE. It also supports Lua too, which is a very similar if not slimmed version of the Python language. This board on top of providing us with a Wi-Fi card for less than \$2, it also includes a USB-TTL included with plug&play, a 10 GPIO pin section for including external sensors and each pin can be Power modulated, a low-power consumption of +5V and PCB antenna.

As we can see this board is a great alternative to any Arduino board that might be compatible with our project. The main advantage here is that the board has the most essential capabilities that we are looking for on a microcontroller, the wireless

communication module, the low power consumption, easy to program code directly into the board and the most important one an extremely low cost which is very beneficial for our assembly.

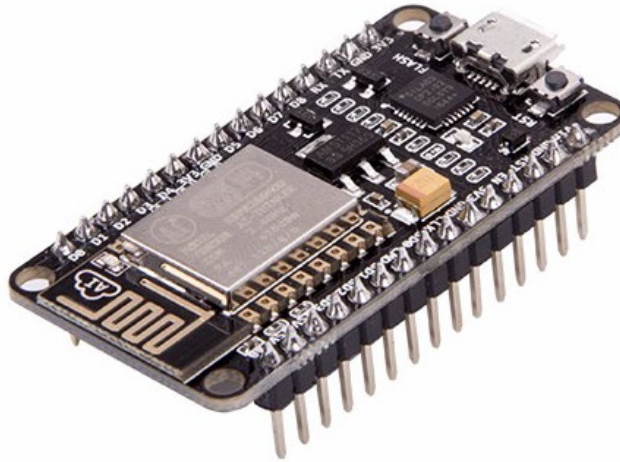

*Figure 12: NodeMCU*

### **Teensy 3.6:**

This Microcontroller is one of the best alternatives to the Arduino Uno which is a very powerful microcontroller and hence it required a bit more assembly and better parts which in other words translates to a bit more investment money. The Teensy 3.6 is a similar size to the Arduino Micro Boards. This board uses a 32-bit 180MHz ARM Cortex-M4 processor, which gives it a tremendous level of computational power for its size. This particular model comes with an onboard microSD card slot for additional memory to be added to it. There are many uses and projects that this little board can accomplish, the main reason why is because you can overclock the processor to get even higher speeds out of this tiny board. The Teensy 3.6 is compatible with the Arduino IDE using their version software called 'Teensyduino', which essentially is a library that works with its own loader software to make writing and uploading code to the board very easy to use. Furthermore, this board comes with a USB HID device included to be compatible with boards that use that type of connection to be recognized.

The teensy 3.6 carries a lot more power than most of the Nano versions of the microcontrollers in the market, this is what makes it very efficient and a good option for our project. It also has very fast writing and reading speeds for the USB ports, which are necessary for the sensors that we need to connect. It has two CAN bus ports, six serial ports (two with FIFO and fast baud rates) needed for fast speed, analog inputs and outputs, Ethernet mac capable of 100Mbit/sec speeds, and many more needed and desired capabilities to be able to integrate all the required assembly.



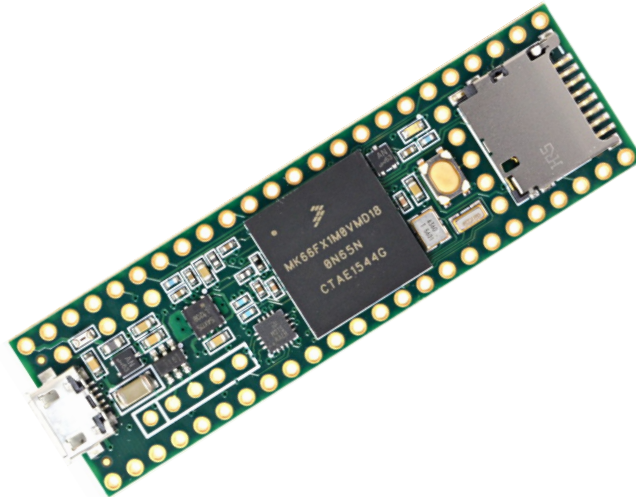

*Figure 13: Teensy 3.6*

### **MSP430 Launchpad:**

This Microcontroller is one of the most widely used microcontrollers in the industry of DIY and Tech development and testing. The main key feature about the MSP430 is that it is a very low power consumption board. The MSP430 is an easy-to-use flash programming microcontroller which was specifically designed to be a low-cost and low-powered device that will be the solution to many draining modules or devices which will not be suitable for certain applications in the field.

According to the manufacturer's specifications, the Launchpad can go on low-powered embedded devices where the current consumption in the idle state is less than 1 micro-amp. The MCU can reach speeds of up to 25MHz. Some of the features found in this Microcontroller are; the internal oscillator, time including PWM, 10/12/14/16/24-bit ADC, and more. The only issue with the MSP430 is that it does not feature an external memory bus, hence it is limited to the on-chip memory of up to 512KB flash depending on the board model. Nonetheless, the MSP430 has great capabilities especially when it comes to the peripherals and boosterpacks.

Similarly, to the shields you can find for the Arduinos you can also find Boosterpacks for the MSP430, these boosterpacks allow you to enhance and expand the capabilities of the board. Boosterpacks are plug-in modules that plug into the header pins of the board allowing it to include extra and different applications for the assembly such as wireless sensing, capacitive touch, external wireless modules, LED lighting control and many more. The MSP430 uses numerous IDE's that Texas Instruments has implemented for the programmability of their boards and circuits. The Energia IDE programming environment is one of the mainly used platforms for programming and uploading code. The only difference between this and the Arduino IDE, is that Energia uses the 'mspgcc' compiler but it is yet based on the Arduino Framework as well.



The programming capabilities of this microcontroller extend beyond the regular coding traditions. The MSP430 has a CCS Cloud-base IDE that enables it to do code editing, compilation and flashing of the TI LaunchPad through the web browser. In addition to that the LaunchPad integrates the ‘Code Composer Studio’, which is a tool for a more advanced use and enables us to better approximate and use the libraries for our project, also including a ULP advisor that tells us when the board is getting the best power consumption.



*Figure 14: MSP430 Launchpad*

### **STM32:**

This Microcontroller is probably the most versatile and powerful to use with any other configurations. The STM32, also known as ‘The Blue Pill’, is similar in size to the Arduino Nano. It also works with the Arduino IDE and it runs on an ARM-based Cortex-M 32-bit processor with an operating voltage of 3.3V. The STM32 offers great performance, real-time capabilities and digital signal processing along with very low-power and low-voltage operation. The board comes with a great variety of chips, but for our project a possible scenario would be using the ‘Blue pill’ specifically. The ‘Blue Pill’ comes with 20KB RAM, 64KB to 128KB flash and a clock speed of 72MHz. One of the main advantages of using this board for some of the necessary tasks on the project would be that the board is very powerful when it comes to adjusting or implementing different tasks with a very low-power consumption. Furthermore, this board goes for a cost no greater than between \$2 and \$6.

This Microcontroller is a very good option for some of the parts or tasks that might be necessary to do separately from the main assembly and without compromising power

consumption and/or compatibility. However, the lack of GPIO pins and connectivity ports, prevents this board from being utilize as our main controller for the project.

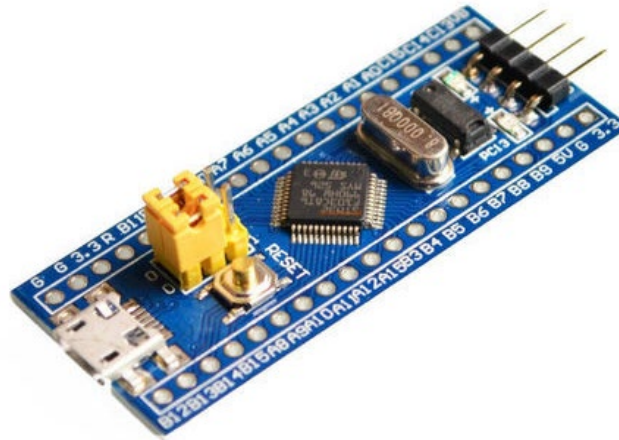

*Figure 15: STM32 'The blue pill'*

### **PocketBeagle:**

This Microcontroller is an alternative to the TI and Arduino family previously mentioned. The PocketBeagle is more like a micro-computer and it has many similarities to the Raspberry Pi Zero. The board comes with a 44 GPIO pins for adaptability and expandability, which is some of the features that we require for our project in order to implement the sensors and the other modules such as the radio or wireless communications and the power controller as well as the Microprocessor itself.

The PocketBeagle is a Linux based microcontroller and it has a little bit of both worlds, the Arduino and the Raspberry Pi. This Linux micro-computer is equipped with an Octavo Systems OSD3358-SM SiP, which integrates a TI Sitara AM3358 with 1GHz ARM Cortex-A8, a 512MB DDR3 with 800 MHz RAM. The PocketBeagle offers 8 analog inputs (6 at 1.8V and 2 at 3.3V), USB 2.0 OTG, Can BUS controllers, 72 expansion pin headers with power and battery, PWM outputs and a bootable microSD card slot. Furthermore, we can use any custom Linux images, Cloud 9 IDE and any of the BeagleBone black software.

As seen this is a very beneficial board for the tremendous capabilities that it possesses, and the ability to run any custom images and most of all the freedom for programming in a Linux based Operating System. The only down-side that could determine if we end up choosing this board over a Raspberry Pi or an Arduino is that the price is listed for approximately \$39.00, which could be a little bit expensive for the project since we are trying to develop a very low cost M-GU4RD

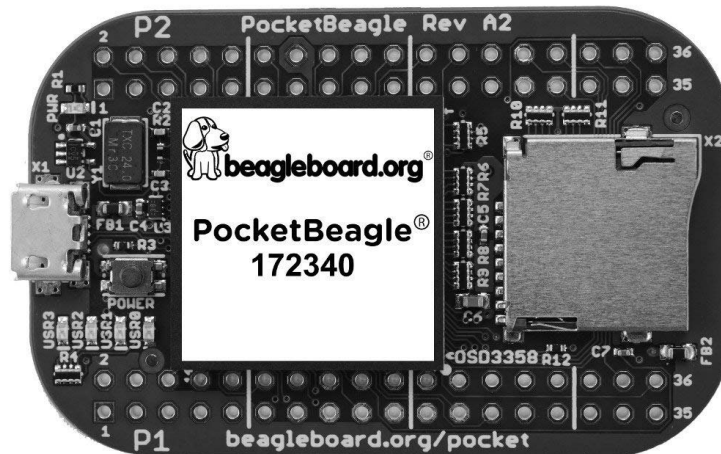

*Figure 16: PocketBeagle*

### **Arduino Uno:**

As a microcontroller, this board is extremely popular with hobbyists and beginners. Its simplistic design, environmental support, and compatibility with multiple devices and sensors makes it easy to use. It is also programmable in C, the basis and gateway to all coding. The latest model 'Arduino Uno R3' supports 14 digital input/output pins and six analog inputs. Unfortunately it only comes with just 32 KB of Flash memory, but this is all that is needed for a microcontroller of this scale. At \$22.57 it is one of the cheapest microcontrollers of its kind.

Although the Arduino Uno contains many user libraries and support it is not as popular among larger tech industries and electronic hardware designers. Its reputation as a development board for beginners undermines it and many in the industry would prefer other development boards as they are more specifically designed and more sufficiently advanced. In addition, the Arduino Uno is not a full on microprocessor so its capabilities with data and memory are not up to par. For the sake of this project this microcontroller is suitable for the job.

The low pricing, ease of use, and variety of sensor support makes it the opportune internal device for the M-GU4RD. Since this project is the team's first large scale design the Arduino Uno is the most suitable and easy to learn. Most of our team is already familiar with this board and every team member is capable of coding in C. Using this microcontroller would also open up the selection of compatible biological sensors that the M-GU4RD could use. If the team uses this board in development, it would definitely be the most convenient selection, but it would most likely need to be paired with a stronger microprocessor to account for its shortcomings.

### **Arduino Mega 2560:**

This Microcontroller is one of the most well-known 8-bit controller in the market. It works with the Arduino IDE platform and sells for about \$40 which is somewhat expensive compared to the Raspberry Pi model. The Arduino Mega has an operating voltage of 5V similar to its competitors. It is equipped with 54 GPIO pins of which 15 provide PWM output, it counts with 16 analog inputs, and 256KB of flash memory. This board also comes with the bootloader to upload code more easily using C language.

To summarize, this microcontroller is also a great alternative for our project, it is capable of the basic functionality for our requirement specifications and it has some more built-in features and modules that we could use.

### **Arduino Nano:**

The Arduino Nano is also a good option for when working and testing on a project that must implement low-powered components in a small design. The Arduino Nano is a breadboard ready version of the Arduino Mini Microcontroller module, which integrates via USB. This board has 8 analog input pins which is more pins than most Arduino boards, it also comes on an Atmel ATmega328 with an operating voltage of 5V. The Arduino Nano features 14 digital I/O pins from which 6 provide PWM output. It comes with a flash memory of 32KB, an SRAM of 2KB and a clock speed of 16MHz. Overall this board is a great starter for when we will be working with our initial design implementations and testing and a possible small factored solution for our overall design.

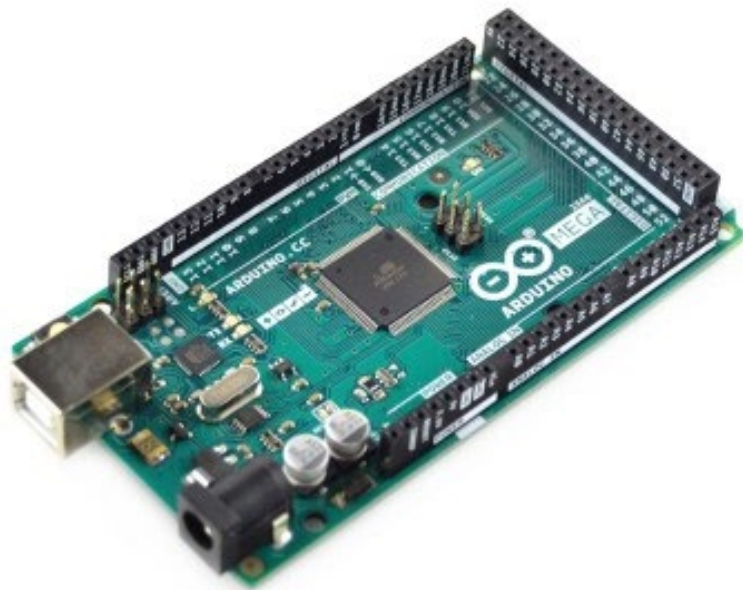

*Figure 17: Arduino Uno R3*





*Figure 18: Arduino Nano*



*Figure 19: Arduino Mega 2560*

Below is a comparison table of the top five microcontrollers the team selected. The one used for the M-GU4RD would need multiple analog inputs to cover for a variety of analog sensors and additional ones that may be installed upon further development. In addition, the microcontroller must be compatible with the microprocessor as well as contain the appropriate memory space.

	Processor	Memory	PIN I/O	Size	Cost
Arduino Uno	Atmega328P	64KB	6	2.7 in × 2.1 in [ 68.6 mm × 53.3 mm ]	\$22
PocketBeagle	1GHz Sitara ARM Cortex-A8 SoC	512MB	8	56mm x 35 mm x 5mm	\$25
NodeMCU	Tensilica L106 32-bit RISC	128KB	12	49mm x 24.5 x 13mm	\$10
MSP430	16-bit RISC	128KB	10	160mm x 154mm	\$20
Arduino Mega	Atmega2560	256KB	16	101.52mm x 53.5mm	\$39

*Table 2: Microcontroller Comparison*

Legend	
	Chosen
	Acceptable
	Not Acceptable

#### 4.1.3 Changes Made in Senior Design 2

A major change in the design included the microcontroller choice for the project. Originally the Atmega328 was the microcontroller for the design; however, the Atmega2560 was used instead for its extra memory and digital pins. More memory was desired since the device needed to constantly collect and transmit data. The extra pins were necessary if additional sensors or features were implemented in the design. Overall the increased size and price of the Atmega2560 did not outweigh the benefits of having a more capable microcontroller.

## 4.2 Biometric Sensor Selection

In order to integrate biological sensors into our M-GU4RD circuit design a few things are necessary, they must be:

- Compatible with either a microprocessor or microcontroller
- Incorporated with an analog-to-digital converter (ADC)
- Unobtrusive to bodily movements

These points are essential as the M-GU4RD has to work properly, in which the sensors are able to read vitals accurately despite movement and maintain comfortability. The information taken from these sensors then has to be translated onto a digital platform that can be saved and utilized on a microprocessor. To do so, the data has to be converted using an ADC. This data can then be represented on the graphical user interface (GUI) where a first-responder's vitals can be monitored. If a microcontroller is used, this would eliminate the use of an ADC as most already include a convertor.

The three main vitals the M-GU4RD will monitor are body temperature, heart rate, and respiration rate.

Body temperature is the easiest of the three vitals to measure. While there are areas along the body that are preferred in medical practice such as the forehead, nose, mouth, rectum, and under the arm. As long as there is contact between the sensor and the skin a decent body temperature reading can be obtained. It would be ideal if the sensor can be used similarly to an electrode attachment and stick seamlessly to the body.

Heart rate can be measured using a few electronic methods. The most commonly used method is by using an electrocardiograph (ECG or EKG). An ECG converts analog signals into a comprehensive waveform that can be mathematically formulated to calculate heart rate at any point in time. This as well as most heart rate monitors involves electrodes being attached to the chest. Another method is by using a pulse oximeter which passes wavelengths of light, normally through the fingers. This method can calculate both heart rate and oxygen saturation. The final method used to detect heart rate is seismocardiography. This involves attaching a form of accelerometer to the chest to detect chest palpitations. In constructing the M-GU4RD the team will focus on using an EKG to obtain heart readings as well as respiration.

Respiration rate has many forms of measurement. Using pneumography is one form of respiration monitoring it is similar to seismocardiography as it also measures palpitations although it does so in regards to respiration. Capnography is another method that measures concentration and pressure of CO<sub>2</sub> in respiratory gases. An Electrocardiogram as discussed prior is primarily used in detecting heart rate but can also be used to measure respiration rate as well. A photoplethysmogram is achieved using a pulse oximeter which in turn also provides respiration rate. Finally, an accelerometry involves similar methods to pneumography.

There are a few ways to go about detecting each vital in order to keep the M-GU4RD as small and ergonomic as possible. Currently the M-GU4RD has two designs. One design focuses on a small wrist mounted device and the other is a larger body mounted device. Using sensors that are already fully developed means sticking to a body mounted device as the electrodes used to detect vitals need to be attached to the chest. Otherwise small chips

can be used to keep a wrist mounted design. The issue with this is keeping the device compact as we will also be adding a microprocessor. These sensors are also harder to find as companies do not readily sell these chips and the accuracy of wrist sensors for vitals are not always up to par with medical sensors.

In constructing the M-GU4RD the team has a few options in regards to sensors. One option is to use a medical development board as they already have working compatible sensors. The other choice is to develop a board from scratch using basic microcontrollers and microprocessors. While it would be easier to use the medical boards to construct the M-GU4RD it would be more educational to start from scratch. Doing it in this way would enable more customization and uniqueness in the design.

Upon further research involving biometric sensors it has become apparent that many companies do not reveal or sell the electronic parts that sense vitals. Instead they sell their own completed products that detect these vitals and incorporate the results onto electronic software. Since this is the case the team has to focus on using what is accessible and this may require taking existing sensors apart to make them compatible with our device or even reverse engineering them. Fortunately some companies used their research to develop microcontrollers and development boards strictly for medical applications. These boards can reliably work with biometric sensors and some even have the capacity to run without other hefty microprocessors or microcontrollers. For the M-GU4RD if we can run these medical boards with a GPS and take the appropriate vitals we can compress our design and condense the boards used on this design to one.

#### **4.2.1 Medical Development Boards**

These development boards are specially made to synch and utilize any and all medical sensors necessary in the medical field. These boards combine microcontrollers with other electrical devices and sensors in order to provide a simpler device capable of performing medical diagnostics without the struggle of looking for compatible sensors. While these devices would be ideal in designing the M-GU4RD they take away from the learning experience as they provide everything in-the-box ready to use.

##### **MySignals Board & Sensors:**

This device is a medical development board capable of storing all vital statistics measured with analog sensors. It then translates this information digitally to an external screen, blue-tooth, or WiFi. Everything is displayed on their own graphical user interface (GUI) which can be found on their application or website. Several medical sensors have already been constructed and programmed to be compatible with this device. This includes an ECG and a body temperature sensor.

This board would be the most ideal in developing the M-GU4RD as it is compatible with both the Raspberry Pi microprocessor and Arduino microcontroller. These two devices work well together and the team is proficient in using them. The MySignals board already acts as an analog-to-digital converter (ADC) and with its many analog inputs a commercial



sensor can be used instead of the standard ones provided by the company. This allows for a fair amount of customization in the device itself. All information taken by this device is stored in the Cloud and can be sent to MySignal's companion application. For the sake of our project, the team would have to reroute the information being received by the analog sensors to our own GUI which will also include relevant GPS information to monitor first-responders.

A main concern with this device is whether or not the team can extract the information from the analog sensors and incorporate it into a different GUI. There is also the issue of finding compatible sensors. All sensors can be bought directly from the company, but the pricing is pretty steep. The MySignal board itself is worth \$379 and its corresponding medical sensors can range in price from \$5 to approximately \$200 depending on how robust and difficult taking the vital can be. In addition, the primary sensors that are needed to construct the M-GU4RD need to be secured to the body. This is a problem as the sensors compatible with this device are meant for medical practice when people are laying down. There is no evidence that these electrodes will hold during movement. The ECG sensor is also a concern as it appears that their device only calculates heart rate and not respiratory rate as well. This device is also relatively new and none of our team is use to using it, although this board is considered easy to use.

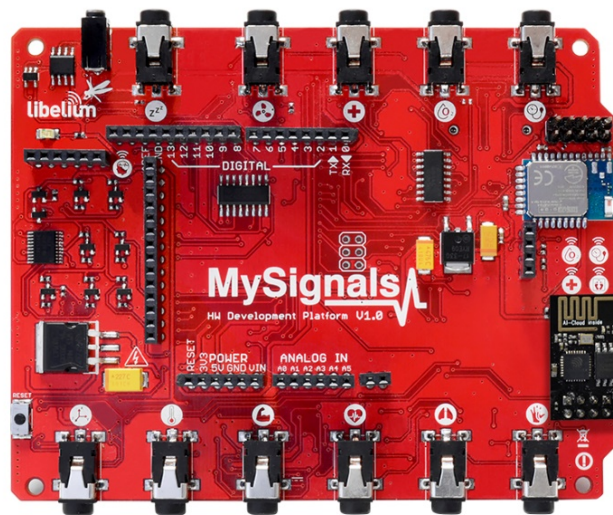

*Figure 20: MySignals Board*

### **BITalino (r)evolution Board:**

This medical microcontroller has a variety of available sensors from EMG, EDA, ECG, EEG, and an accelerometer. The EMG detects electrical muscle movements, the EDA is commonly used in lie detection, the ECG monitors the heart and respiration, and the EEG diagnoses brain activity. All these sensors can be used to monitor first-responders using

the M-GU4RD. The BITalino board itself is segmented so that it can be split apart and used for different designs if not as a whole. The complete set along with electrodes and power supply costs \$209.95.

The BITalino like most microcontrollers already has an analog-to-digital converter (ADC) which makes it a lot easier to send and interpret sensor information. Along with 6 analog inputs, 4 digital inputs, and 4 digital outputs there are plenty of pins for adding more sensors. There is also access to the digital information received by the sensors called “OpenSignals” which is necessary in constructing our own graphical user interface (GUI). In addition this board can be programmed and interfaced into virtually anything including Arduino, Python, Java, Android, iOS, and more. This makes programming a breeze as the team has a vast selection of programming languages to choose from.

The biggest disadvantage this device has its communication capabilities. It can only communicate via blue-tooth to a computer. For the M-GU4RD a larger communication radius is necessary. If this board is utilized the team would need a module, some other device, or chip that can connect to this board and relay information, preferably over Wi-Fi. This device also lacks a body temperature sensor.



*Figure 21: BITalino (r)evolution Board*

### **MAXREFDES100:**

The MAXREFDES100 is a health sensor with a vast variety of medical sensors. These sensors includes motion measurement, skin temperature, biometric measurements (ECG, EMG, and EEG) and PPG (pulse oximetry and heart-rate). With a 32-bit MCU and 32MB of flash memory this device has all it needs and the space to do it. The board also includes a graphical user interface (GUI). This is at a price of \$156.25.

This device in particular is one of the smaller boards compared to the rest. It also includes a larger variety of usable sensors. While the MySignals board has the most support with sensors this device is relatively close. The biggest benefit of this board is the fact that this board can fit on the wrist which is invaluable in constructing the M-GU4RD.

### **Olimex Medical Series TI MSP430 Development Boards:**

The Olimex Medical Series is based on the TI MSP430 and consists of two board modifications, a MOD-EKG and MOD-PULSE. With 60KB+256B Flash memory and 2KB RAM it can hold a decent amount of data. This device already incorporates an analog-to-digital converter and the modifications include an EKG and pulse oximeter to measure heart rate and respiratory rate. Each mod has a cost of \$31.09.

This development board is unique in comparison to the other medical boards because it includes an LCD display to view the data collected by the sensors. In addition the device is based directly off the MSP430 a device the team is very familiar in programming and utilizing.

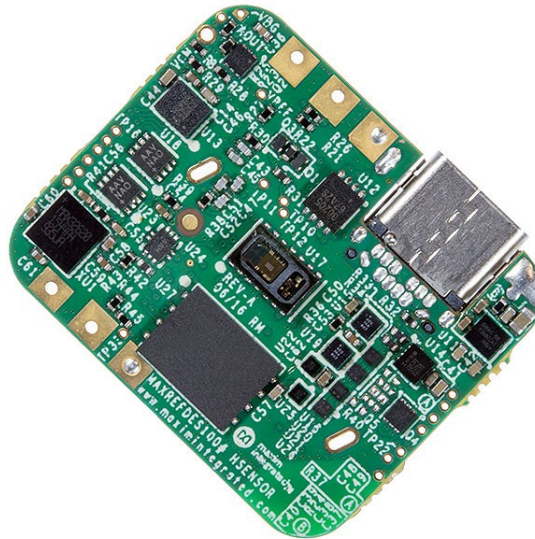

*Figure 22: MAXREFDES100*



*Figure 23: Olimex Medical Series Board*

### **TWR-MCF51MM:**

The TWR-MCF51MM: ColdFire MCF51MM Medical Development Tower System Module is a medical development board with EKG support. Running on a 32-bit MCU this board is compatible with heart rate monitors, blood pressure monitors, pulse oximeters, and a record saving system. There is even an 8-bit MCU variant for a more compact device. In addition this board has USB, bluetooth, and wireless radio communication support. The TWR-MCF51MM can be bought as a full kit, EKG and electrodes included for \$149 or as just the board for \$59.

Similar to the other medical development boards this device has an EKG, but lacks a body temperature sensor. It is also unknown what kind of programming language this device supports which can prove problematic since it's a device the team is unfamiliar with.



*Figure 24: TWR-MCF51MM Board*

#### 4.2.2 Vital Sensors (ECG & Body Temperature)

Another option available aside from the medical development boards is obtaining compatible sensors with our choice of microcontroller or microprocessor. This allows for more flexibility and customization choices when constructing the M-GU4RD, but instead requires more intense research into certain components to make sure they are compatible with our build. This design will allow for further testing involving additional sensors that can be added and can increase our experience as it requires more knowledge and skills.

##### **BMD101 (NeuroSky CardioChip):**

A small sensing electrode used for wrist mounted devices that presents an ECG/EKG reading that can calculate heart rate and respiratory rate. This product is advertised as being for anything from recreational use to athletic monitoring and health tracking. It even has measurements for stress, fatigue, heart age, mood, breathing index, and heart rate index with more features currently being developed. The BMD101 starter kit costs \$50 to \$60 and has everything needed to start taking vitals.

The chip itself is small in size at approximately 10 mm and utilizes a single metal electrode that must touch the skin in order to obtain readings. This design would be perfect in constructing a more condensed M-GU4RD in addition to being compatible with Android and Windows devices.



*Figure 25: BMD101 Chip*



### **AD8232 ECG Sensor Module:**

This ECG device runs on a low 170 $\mu$ A and 3.3V and costs \$15.99. With Arduino compatibility, this module is a cheap solution to retrieving heart rate information for the M-GU4RD. This device includes the use of three sensor pads that can be attached to the firefighter. Typically these pads are placed on the arms and one leg. Muscle noise is the undesired effect associated with readings of the pads placed in areas of high muscle activation. To reduce the effect of this muscle noise, these three pads can be placed closer to the heart. Being closer to the heart works in the favor of the M-GU4RD design as it will be easier to set up for first responders. The pads however would need to be replaced after each use as they lose accuracy over time. 10 pads can be purchased for \$7.95. Another issue with these pads is that they would not be as accurate if placed on body hair, which may or may not be present on the firefighter.

The advantages in using this device for the M-GU4RD are the low cost and power, the compatibility with Arduino microcontrollers, the small size and portability, and the abundance of information online regarding how the device can be used and its limitations. The drawbacks to utilizing this device for this project are the need to replace the pads after each use to ensure accurate measurements, longer installing time due to having several pads, and that motion may be a big issue when taking measurements. Overall this device should be able to obtain the data needed, however, if used in practice, meaning a firefighter running through a building and moving around excessively, it may not be capable of performing its duty. While the price is cheap, it may not work for this application, but at that price it would not be a bad idea to test it out.

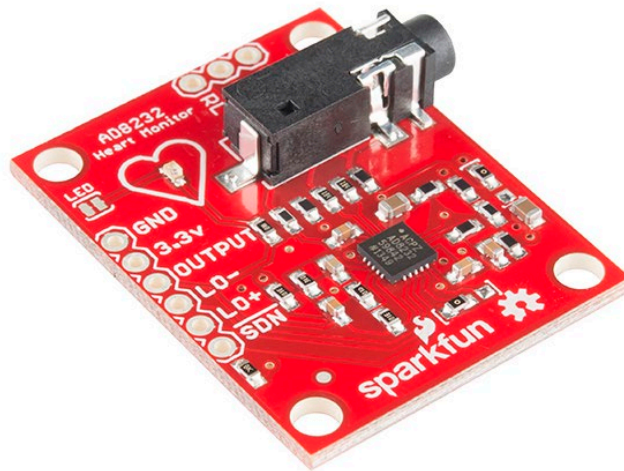

*Figure 26: AD8232 Chip*

### **Raspberry Pi Heartbeat/Pulse Sensor:**

This sensor is one of the many Raspberry Pi sensors available and it tracks heartbeats/pulse. It works by monitoring heartbeats and records the last measured value as the pulse. In order

to properly represent this data digitally an analog-to-digital converter is needed. In terms of accuracy, it is not the most efficient device. Sometimes it does not accurately read pulse due to how touch sensitive it is. It is also known to update relatively slowly compared to other commercial devices. It also appears to only work through contact with the finger which would compromise the team's device of being ergonomic. Overall this device, although convenient due to its cheap pricing and compatibility with the Raspberry Pi, is not very practical.

### **Waterproof DS18B20 Digital Temperature Sensor:**

The DS18B20 is a three-wire digital temperature sensor that operates in the temperature range of  $-67^{\circ}\text{F}$  to  $257^{\circ}\text{F}$ . The accuracy of this sensor is  $\pm 0.9^{\circ}\text{F}$ , which may be accurate for general purposes, may be a bit too inaccurate for measuring body temperature given that normal body temperature ranges from  $97^{\circ}\text{F}$  to  $100^{\circ}\text{F}$ . This accuracy uncertainty is roughly 33% of the range that it will be used to monitor. The accuracy is still very good however in giving the general temperature of the body. This sensor comes with the option of a 3ft or 6ft cable and runs from \$5 to \$10. The sensor is encapsulated by stainless steel to give a bigger surface area for which thermal conduction can take place for the sensor to read. This may prove to be dangerous in a scenario where this device is attached to human skin in a very hot area in that the steel may heat up and burn the person. The firefighter coat, however, should be enough insulation to prevent the steel from heating up, but if not, modifications to the sensor package can be made so as to avoid such issues. Overall this device is a very good choice for this project for the reasons that it is a simple one wire data sensor, it has reasonably good accuracy for the application, it is inexpensive, and can be modified to attach to skin on the body easily. The question would be where would be the best place to attach the sensor to get a good body temperature reading?



*Figure 27: Raspberry Pi HeartRate/Pulse Sensor*



*Figure 28: DS18B20 Digital Temperature Sensors*

#### **MCP9808 High Accuracy I2C Temperature Sensor Breakout Board:**

This temperature sensor comes on a breakout board and has a temperature operating range of  $-40^{\circ}\text{F}$  to  $267^{\circ}\text{F}$  with a typical accuracy of  $\pm 0.45^{\circ}\text{F}$ . The device utilizes I2C control and is compatible with any such microcontroller. With the low cost of \$5, this device is small and has a great accuracy for this application. If this sensor is used in this project, modifications would be necessary to make the device attachable and usable on a human. It runs on 2.7-5.5V and draws only  $200\mu\text{A}$ . This is a great option for the M-GU4RD due to its low cost, high accuracy, small size, and low power consumption. Some disadvantages to using this sensor is the need to modify or create a casing for the device so that it can be attached to the skin of a human and take good readings.

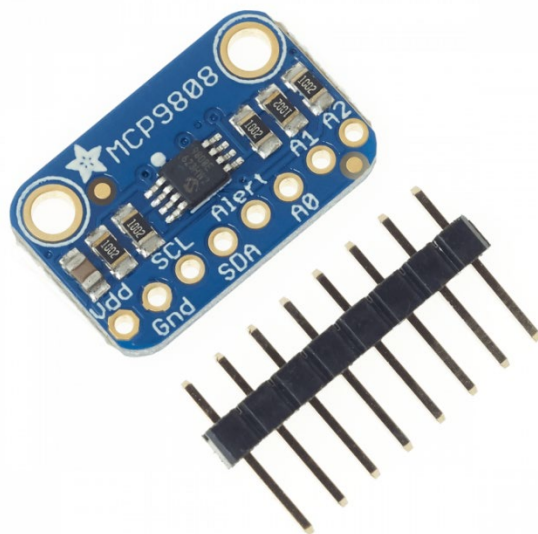

*Figure 29: MCP9808 High Accuracy I2C Temperature Sensor Breakout Board*



Temperature Sensor	Accuracy	Range	Size	Cost	Power Consumption
<b>DS18B20</b>	±0.9°F	-67°F to 257°F	1m*50mm*50mm	\$5-\$10	3.0-5.5V
<b>MCP9808</b>	±0.45°F	-40°F to 267°F	21mm*13mm*2mm	\$5	2.7-5.5V and 200µA

*Table 3: DS18B20 and MCP9808*

Additional Notes	
DS18B20	MCP9808
<ul style="list-style-type: none"> <li>• Packaged in a way that it can be used directly.</li> <li>• Simple three-wire connection.</li> <li>• Waterproof.</li> </ul>	<ul style="list-style-type: none"> <li>• Not a very convenient size and shape to implement as a body temperature sensor.</li> </ul>

*Table 4: MCP9808 vs DS18B20 additional notes*

The DS18B20 temperature sensor was chosen for the M-GU4RD for many reasons. The DS18B20 sensor is waterproof so it has a larger range for application and environments in which it will work. Also, this sensor comes set up with a cable and is packaged so that the device can easily be used to measure the temperature of the body by direct contact to the skin. Although the MCP9808 is slightly more accurate, the DS18B20's packaging convenience outweighs the increased accuracy.

The manufacturer chosen for the DS18B20 was Aideepen. The reason for choosing Aideepen for this product was because they offered a 5 pack for \$12. The importance of getting a 5 pack is that if while testing the device it breaks, then there are back-up sensors that will be readily available. Not only was the price cheaper, but the ratings on Amazon were the highest at 4.5 out of 5 stars.

#### **4.2.3 Changes Made in Senior Design 2**

The chosen ECG module for this project was changed to the ADS1292R. The reason for this change was primarily due to the fact that it was a heart rate sensor as well as a respiration rate sensor. There were many resources online on how to program this module and the design fit the application of the M-GU4RD very well. Its price was \$60 which is

not bad considering that these sensors are the most crucial to the M-GU4RD's purpose and application.

### **4.3 Global Positioning System (GPS) Selection**

There are many different types of navigation systems such as GLONASS (Russia), IRNSS (Indian), Bei-Dou 2 (China), Galileo (European), and NAVSTAR (American) which is the one referred as GPS. This last one is the most utilized system. GPS consists in a network of Satellites located approximate 20,180 km above sea level. The system set up ensures that no matter the location in Earth there will always be a minimum of 4 Satellites with direct Line-of-sight to the receiver. These satellites transmit two signals that will travel at the speed of light. One of the signals being the position and the other their current time (this is a very precise timestamp obtained through atomic clocks) both signals will be sent at regular intervals.

By using a very common example of a receiver such as a cellphone it is possible to understand how this receiver will calculate the distance between them and the Satellites. Once this receiver has information of at least three satellites this will help it to pinpoint where in earth is located with an error of typically 10-15 meters. This process is known as Trilateration. A simple way to understand this process is to represent the distance between the receiver and each satellite as the radius of a circle and the receiver being in the edge of this radius. By drawing these multiple circles around each of the satellites it is possible see where these circles intersect therefore predict where the receiver is located.

Although there are multiple factors that can contribute to this error the most significant is the one due to the Ionosphere. This improves when the Satellite are directly above the receiver. As mentioned before these Satellites contain atomic clocks and small variations in these clocks such as nanoseconds delay will affect the accuracy of the system. Here is where Relativity comes in since the clocks on these satellites will run slower than the ones on Earth. All these aspects are taking in consideration when developing a Global Positioning System (GPS).

The GPS module is a key component to the M-GU4RD device. The purpose of the GPS is to retrieve information on the location of the firefighter on the surface of the Earth. The GPS utilizes several satellites to triangulate the location of the device on the Earth. This information can be displayed on the GUI to indicate where the firefighter is located in the building, with the exception of altitude information for cases where a firefighter is on a different floor. A separate device would be necessary to add information indicating what floor the firefighter is on.

There are many aspects to look at when choosing what type of GPS module to utilize. Some factors that are of major importance are refresh rate, size, power, antennas, number of channels, and accuracy. Ideally one would want a small, accurate device that refreshes frequently and is efficient. For the purpose of the M-GU4RD, the refresh rate does not necessarily have to be very high since one will typically not have a large change in position within one second of time, which is the typical update rate of GPS modules. Most GPS

modules are very small, so that size requirement is basically met by most modules. Accuracy is definitely crucial in that it will allow one to know exactly where the firefighter is located. The module as well as the antenna must be considered when choosing which device to get.

### **SparkFun GPS Module Copernicus II DIP:**

This GPS module costs \$74.95 and has an update rate of 1Hz, which is decent for the application. The device measures 31.8mmx27.4mmx14mm and has a cold restart time of 38s and a hot restart time of 3s. The size is small enough for the application and the start-up time is not too big of an issue for this application, because ideally the firefighter will have the device installed and powered on well before entering the building. Comparatively however, the cold restart time is longer than other modules. The device is quite expensive, but the device includes an external SMA connector for the external antenna. Also, the device is sold as a stand-alone (not including the SMA connector) for a cheaper \$44.95. The power required for this unit is 3.3V and 44mA, which is a pretty decent power consumption compared to other modules. This device also has 12 channels, which is also a decent amount. Overall this device would suffice for the application at hand, though it is on the expensive side.



*Figure 30: SparkFun GPS Module Copernicus II DIP*

### **SparkFun Venus GPS:**

This GPS module has dimensions of 30mmx18mmx14mm and costs \$49.95. The cold restart time is 29s and the hot restart time is 1s. The device can run at a max 20Hz update rate and consumes power at 3.3V and 29mA. This module comes with an external SMA connector for an antenna and has 14 channels. The specifications of this device meet the requirements for the M-GU4RD by a great degree and is not too expensive. This device overall would be a better choice for this project considering the faster start time, smaller size, the higher update rate, lower power, more channels, and lower price.



*Figure 31: SparkFun Venus GPS*

**EM-506 GPS Receiver:**

This module has 48 channels and 2.5m accuracy. This device has an antenna installed and a 6 pin interface cable attached. The cold restart time is 35s and hot restart time is 1s. The power consumption of this module is 4.5-6.5V and 45-55mA and the size is 30mmx30mmx10.7mm. The update rate is 1Hz. For the price of \$39.95, this module also satisfies the requirements for the M-GU4RD application. The power consumption is higher than other modules, but that is due to the fact that the antenna will need power as well. This device would also be a great candidate due to the fact that it meets the requirements and is considerably cheaper than other options.



*Figure 32: EM-506 GPS Receiver*



*Figure 33: NEO-6M GPS Module*

### **NEO-6M GPS Module:**

This device is compatible with Raspberry Pi, Arduino, MSP430, and MSP432. The NEO-6M has a max update rate of 5Hz and a position accuracy of 2m. The receiver has 50 channels, cold start time of 26s and hot start time of 1s. The device is a little smaller than other modules with dimensions of 36mmx25.8mmx4mm and also comes with an antenna with dimensions of 25.5mmx25.5mmx8.8mm. The power requirement is 3.6V and 39mA and the cost of the device is \$15.95. Overall this device will satisfy the needs of this project and is cheaper than the other modules by a substantial amount. Using this module would be most advantageous to our team, because it is compatible with both the Raspberry Pi and Arduino, which are most likely the processors and controllers we will use, it comes with an antenna, has a high refresh rate, a large number of channels, quicker start times, and cheaper than all the other options. In addition, many hobbyists use this module for drones, so information on utilizing this module is abundant.

The table below displays the relevant specifications of each GPS module discussed to compare each device with each other. This table will help in deciding which module would be best to use in this project based on the different specifications and what is required.

Module	Size (mm <sup>3</sup> )	Power	Number of Channels	Accuracy	Refresh Rate	Cost	Antenna Included
SparkFun Copernicus II	31.8x27.4x14	3.3V 44mA	12	4m	1Hz	\$74.95	No
SparkFun Venus	30x18x14	3.3V 29mA	14	2.5m	20Hz	\$49.95	No
EM-506	30x30x10.7	4.5-6.5V 45-55mA	48	2.5m	1Hz	\$39.95	Yes
NEO-6M	36x25.8x4	3.6V 39mA	50	2m	5Hz	\$15.95	Yes

*Table 5: GPS Module Comparison*

Legend	
	Chosen
	Acceptable
	Not Acceptable

The GPS chosen for this project was the NEO-6M GPS unit. The main reasons for choosing this module in particular is the extremely low cost in comparison to the other modules, the relatively similar quality in comparison to the other modules, the fact that it comes with an antenna, and because of the abundance of information online on using this device for different applications. Choosing a cheaper device will keep us within our budget and the quality should be more than enough for the application of the M-GU4RD.

The module is accurate enough, small enough, fast enough, and has low enough power consumption. A very crucial factor that led the group to choose this device is the fact that it is compatible with arduino microcontrollers and raspberry pi's and many hobbyists use this device. Due to the access of information on using this device, the group may be able to refer themselves in the case of running into issues with the device. These forums and videos can provide resources to troubleshoot issues with the device.

The manufacturer chosen for the NEO-6M GPS module is DIYmall. Though Geekstory's module is about a dollar cheaper, the DIYmall device had higher ratings and reviews on Amazon. A higher quality or more reliable device is worth an extra dollar, so that is why the group decided to purchase the DIYmall model for this project.

## 4.4 Wireless Communication Options

Wireless communication is caused by a disturbance in the electromagnetic field. This will result as the creating of electromagnetic waves and these waves will propagate, due to this propagation it is possible to send information in these waves. The existence of these electromagnetic waves was predicted by Maxwell's equations 1865.

A simple way to visualize this phenomenon is by using the example of a lake and a rock. If a rock is thrown in a lake it is possible to observe how this will create multiple ripples and since these ripples move, they can be called waves. Another simple example to understand is how soundwaves travel in the air carrying information that people can hear and understand. As the electrons travel along an antenna this will create a disturbance in the field which will cause a propagation of electromagnetic waves into space. There are multiple types of waves in the Electromagnetic Spectrum such as gamma rays, x rays, ultraviolet, visible light, infrared, microwave and radio waves. These types of waves are separated depending on their wavelength. This measure is obtained by taking the distance between two peaks of the wave.

A very common technique to send data is by using Amplitude Modulation (AM). This type of electronic communication works is by sending a carrier wave and varying the amplitude of it to match the desired signal wanted to transmit; in other words, the message is carried in the variation of the amplitude of the carrier wave. AM is commonly used in radios, AM Radios most specifically. Another type of electronic communication is by using Frequency Modulation (FM). Similarly, FM utilizes a variation in the instantaneous frequency of the carrier wave to send a message, one main advantage of using Frequency modulation is having less chance for distortion in the message. FM is utilized to send digital information; this technique will make a certain frequency a one and another frequency zero. The receiver will take the message and start the decoding by looking at the different frequencies in the carrier wave. There is a third technique called Phase Modulation (PM) in which the phase of the carrier wave is varied to send the message. As the options for Wireless communications are multiple there will be three main options analyzed for this project. Wi-Fi, Bluetooth and using RF modules.

### 4.4.1 Wi-Fi (2.4 GHz – 5 GHz)

Wi-Fi is a very common type of wireless communication. To briefly explain it let's use a common example of a home computer. This computer will be receiving wireless information from a router, this router will be connected by Ethernet cable to a modem and this modem to the internet, similarly to how the in the old days a phone was connected to a phone line. Wi-Fi mainly uses 2.4 GHz and 5 GHz since these frequencies work best for Line-Of-Sight Communication. Although, many materials can absorb and reflect these waves and restrict their range this can also help to minimize interference between them.

To utilize this type of communication for the M-GU4RD a mobile router it is required; this works as the one mentioned above but, instead of being connected to a cable this will have a SIM card. This will enable to set up a private internet connection anywhere in the world.

In home networks Wi-Fi routers can achieve a range of up to 150 feet (46 meters) for indoors and 300 (92 meters) for outdoors. Also, it is important to point out that as the frequency increases the signal is more susceptible to interference inside buildings. This can create a problem for the M-GU4RD since the most common scenario for these devices will be residential buildings. For this reason, other options are being taken in consideration such as Bluetooth, another very common type of wireless communication.

#### **4.4.2 Bluetooth (2.402 GHz – 2.480 GHz)**

Bluetooth is a very popular type of wireless communication. This type of wireless communication was developed by the telecommunication company Ericsson in 1994 and originally called “Short Link Radio Technology” and kept that name until 1997 when the name was changed to “Bluetooth”. This connection is automatic, and it offers many different features.

A big advantage of this method is how power efficient it is. Bluetooth communicates mainly between 2.402 GHz and 2.480 GHz; this band is called ISM band which stands for Industrial, Scientific and Medical band. This method works by sending very low power radio waves which is beneficial to avoid interference with other devices.

Bluetooth devices come in three classes. Class one is mainly used in industrial application and can provide a range of approximately 100 meters. Class two is the most popular and it is the one utilized in headphones or mobile phones with a range of 10 meters. Class three has a small range of 1 meter and is not really applicable. Bluetooth allows to connect up to seven devices to one device by creating a Personal Area Network (PAN) also called “Piconet”.

A very common concern when it comes to Bluetooth is the carry of sensitive data. This is a misconception since it is possible to implement several security modes. Service-level security and device-level security work together to make sure the network is protected against unauthorized devices. The user can also change its network to “no-discoverable” to avoid the connection with other devices. These are all important aspects to take in consideration when deciding what type of wireless communication will be implemented in the M-GU4RD. While researching about Bluetooth another type of communication came to our attention; Bluetooth Low Power (BLE) became another option for the M-GU4RD.

BLE is comparable to the classical Bluetooth but with a considerable reduction of power while maintaining a similar range. This type of communication utilizes the same range as the classic Bluetooth with the difference of a much simpler modulation system. Although this Low Energy type of communication seems like a good option a disadvantage of BLE is when sending large amount of Data. In that case Classic Bluetooth would be more suitable for that application.



As Bluetooth brings advantages such as the power consumption and easy to implement a third option needs to be analyzed to make the right decision for the design and functionality of the M-GU4RD.

#### **4.4.3 Radio Frequency Module**

The main constraints when designing any type of wireless communication are the range and the amount of data that the design needs to transmit. RF modules are very small in size and wide operating voltage range (3V-12V). These modules consist in two main parts; the transmitter and receiver. These modules have a very large range of up to two kilometers. RF modules are mainly 433 MHz, this band is an ISM band and it's free to use in many countries.

RF transmitter consist in a small Printed Circuit Board sub-assembly capable to transmit data through modulation of the carrier wave. This transmitter will draw no power while sending the logic zero, this result beneficial in the power consumption aspect. While when sending the logic while this will send full power of the carrier wave.

RF Receiver module receives the modulated signal and translate it. There are two main types of receivers; these are super heterodyne receivers and super-regenerative receivers. This last type of receiver consists in a series of amplifier to extract the modulated signals, they tend to be low power and low-cost designs. A disadvantage of these types of receiver is how imprecise they can be due to their dependency in frequency caused by temperature and power supply voltage. On the other hand, super heterodyne receivers are much more accurate and stable when it comes to large voltages and temperature range. This higher accuracy and stability are caused by their fixed crystal design, this used to an issue in the past when considering prices between these two types of receivers but, due to the advances in technology both of these receivers became very similar in price.

There are also Transceiver modules which consists in both the receiver and transmitter. This design typically consists half duplex operation. These modules tend to be higher price due to its complexity.

Some of these very popular RF Modules will be analyzed in this next section.

#### **SMAKN® 315 MHz RF Transmitter and Receiver link kit:**

This wireless transmitter is very basic and easy to fit into the breadboard. The average does not exceed \$10 making this a very cost-effective alternative. The working principle of this is single chip super-regeneration receiving. This will communicate data only one way therefore if needed a two-way communication link the design will require a pair of these with different frequencies. These modules receive a fair amount of noise therefore filtering techniques need to be implemented to have a good link of communication. Most of these receivers have a sensitivity of -105 dB and the entire logic circuitry works on 5 volts.

The RF Module analyzed for this design is the UCEC XY-MK-5V / XY-FST 315 MHz RF Transmitter and Receiver Module link kit. This module is compatible with multiple microcontrollers such as Arduino, Arm and Raspberry Pi

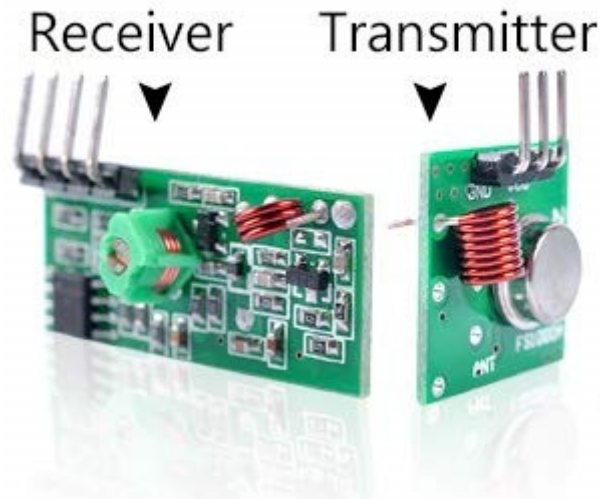

*Figure 34: SMAKN® 315 MHz RF Transmitter and Receiver link kit*

#### Specifications

- Working voltage: 3V-12V
- Working current: 20-28mA.
- Working temperature: -10 degree to +70 degree
- Resonance mode: sound wave resonance (SAW)
- Modulation mode: ASK /OOK
- Working frequency: 315MHz
- Transmission distance:>500m, sensitivity to -103dBm, in open areas.
- Transmission power: 25mW (315MHz at 12V)
- Frequency error: +150kHz (max)
- Transfer Rate: 10 KB/S
- Rx Bandwidth: 2MHz

#### **APC220 Wireless RF Modules:**

This is another module that provides a simple and economic wireless data communication system. The average cost is \$40. This semi-duplex low power transceiver not only transmit transparent data but also provides more than a hundred channels. This transceiver utilizes high efficiency forward error correction with interleaving encoding technology which highly improve the anti-interference and sensitivity. This module seems to be a good fit for the design and application the M-GU4RD is trying to achieve.



**Figure 35:** *APC220 Wireless RF Modules*

#### Specifications

- Working voltage: 3.5 – 5.5 Volts
- Transmit current:  $\leq 42\text{mA}$  @ 20 mW
- Receiving Current:  $\leq 28\text{mA}$
- Working Temperature:  $-30^{\circ}\text{C}$  -  $85^{\circ}\text{C}$
- Modulation Mode: GFSK
- Working Frequency: 418MHz to 455MHz (434 MHz default)
- Transmission Distance: 1000m (open space)
- Transmitted Power: 20mw (10 levels)
- Transfer Rate (Air): 2400 - 19200bps (9600bps default)
- UART Rate: 1200 - 57600bps
- Receiver Sensitivity:  $-113\text{dBm}@9600\text{bps}$
- Dimensions: 37.5mm x 18.3mm x 7.0mm

#### **Solu CC1101 Wireless Transceiver Module:**

This device counts with multiple carrier frequencies such as 315, 433, 868 and 915 MHz, making it a very versatile design. This transceiver was designed for low power applications and integrated with a baseband modem which supports multiple modulation formats and allows to configurate the data rate up to 600 KB/S. The maximum power transmission is 10 mW. The main operating parameters and 64-byte Tx/Rx FIFO can be controlled using SPI protocol.

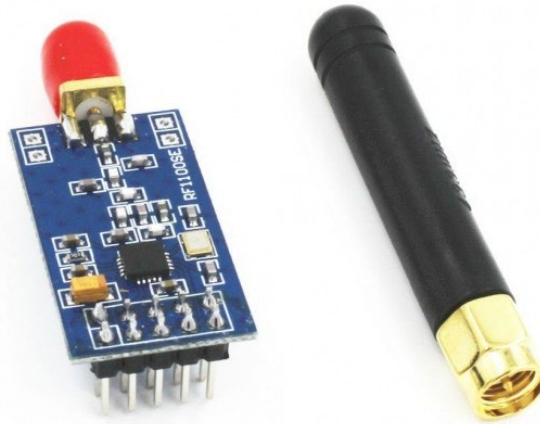

*Figure 36: Solu CC1101 Wireless Transceiver Module*

#### Specifications

- Working voltage: 1.8V-3.6V
- Working current: <30 mA
- Working temperature: -40 degree to +85 degree
- Resonance mode:
- Modulation mode: Support 2-FSK, GFSK and MSK
- Working frequency: 387-464MHZ
- Transmission distance: approx. 3000 meters
- Transmission power: 10mW (+10dBm)
- Transfer Rate: 0.6 – 600 kbps
- Receiver sensitivity -110dBm at 1200 baud

#### **SMAKN® 433Mhz Rf Transmitter and Receiver Link Kit:**

This module is one of the most popular RF modules utilized. The frequency of operation is an ISM frequency. When it comes to size this module is very small, many of the specifications are quite similar to the 315 MHz shown before. The range of this module is approximate 400 meters. This design is well known for having good quality, reliable, and excellent data acquisition.

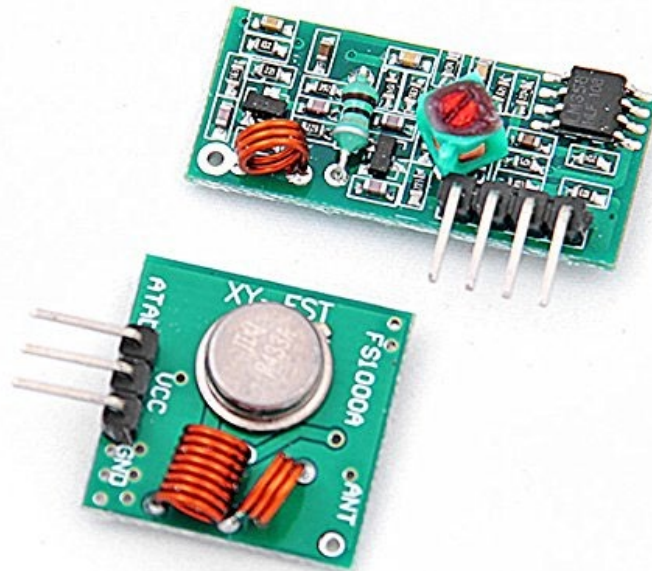

*Figure 37: SMAKN® 433Mhz Rf Transmitter and Receiver Link Kit*

#### Specifications

- Working voltage: 3V-12V
- Working current: 20-28mA.
- Working temperature: -10 degree to +70 degree
- Resonance mode: sound wave resonance (SAW)
- Modulation mode: ASK /OOK
- Working frequency: 315MHz-433.92MHz, customized frequency is available.
- Transmission distance:>500m, sensitivity to -103dBm, in open areas.
- Transmission power: 25mW (315MHz at 12V)
- Frequency error: +150kHz (max)
- Velocity: 10Kbps
- Self-owned codes: negative

#### RX Technical Specifications:

- Working voltage: 5.0VDC
- Static current:4MA
- Working temperature: -10 degree to +70 degree
- Working principle: single chip super-regeneration receiving
- Working method: OOK/ASK
- Working frequency: 315MHz-433.92MHz, customized frequency is available(266-433MHZ).

- Bandwidth: 2MHz (315MHz, having result from testing at lowering the sensitivity 3dBm)
- Transmitting velocity: <9.6Kbps (at 315MHz and -95dBm)

### **Refaxi 2 Set 433Mhz RF Receiver Transmitter Module:**

While doing the research it is important to find a module that can operate in different types of microcontrollers. “SMAKN® 433Mhz Rf Transmitter and Receiver Link Kit” is a good option although it is not compatible with the Raspberry Pi, therefore other similar modules are analyzed to find compatibility with this microcontroller in case the M-GU4RD requires to utilize the Raspberry Pi. The Refaxi 2 offers very similar specs to the SMAKN® but also compatibility with Arduino/ARM/MCU WL Raspberry Pi.

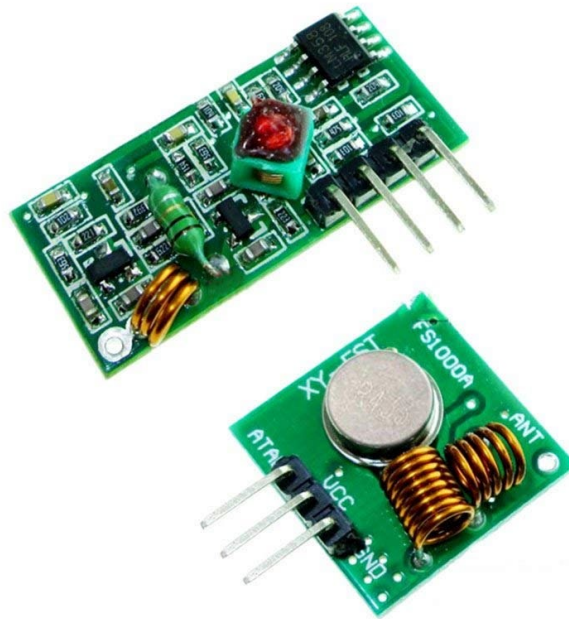

*Figure 38: Refaxi 2 Set 433Mhz RF Receiver Transmitter Module*

#### Specifications

- Operating voltage: DC5V
- Quiescent Current: 4MA
- Receiving frequency: 433.92MHZ
- Receiver sensitivity:-105DB
- Actual working Distance: 50-100m
- Transmitting Frequency: 433M
- Transmission Distance: 20-200 m (different voltage, different effect)
- Working Voltage: 3.5-12V

- Size: 30 \* 14 \* 7mm
- External antenna: 32CM single core wire, wound into a spiral

#### Transmitter

- 100% Brand New
- Product Model: MX-FS-03V
- Launch distance :20-200 meters (different voltage, different results)
- Operating voltage :3.5-12V
- Dimensions: 19 \* 19mm
- Operating mode: AM
- Transfer rate: 4KB / S
- Transmitting power: 10mW
- Transmitting frequency: 433M
- An external antenna: 25cm ordinary multi-core or single-core line
- Pinout from left to right: (DATA; VCC; GND)

#### **nRF24L01+ 2.4GHz Wireless Transceiver:**

nRF24L01 is a single chip transceiver that operates in the ISM band between 2.4 - 2.5 GHz. This transceiver operates as a fully integrated frequency synthesizer, a power amplifier, a crystal oscillator, a demodulator, modulator and Enhanced ShockBurst™ protocol engine. The output power as well as the frequency, number of channels and protocol are relatively easy to program utilizing a SPI interface. This design also contains a built-in power down as well as stand-by mode which contributes in helping to save power. One issue with this design is the complexity to implement due to software as well as the how bust the band of 2.4 GHz is in the United States.

#### Specifications

- Working voltage: max 1.9V – 3.6V
- Transmit current: 11.3 mA
- Receiving Current: 12.3 mA
- Working Temperature: -40°C - 85°C
- Modulation Mode: GFSK
- Working Frequency: 2.4-2.5 GHz
- Transmission Distance: approx. 100 meters
- Transmitted Power: +4 dBm (Max)
- Transfer Rate (Air): 2000 kbps
- Receiver Sensitivity: -85dBm@1000kbps
- Communication Protocol: SPI
- Chanel Range: 125

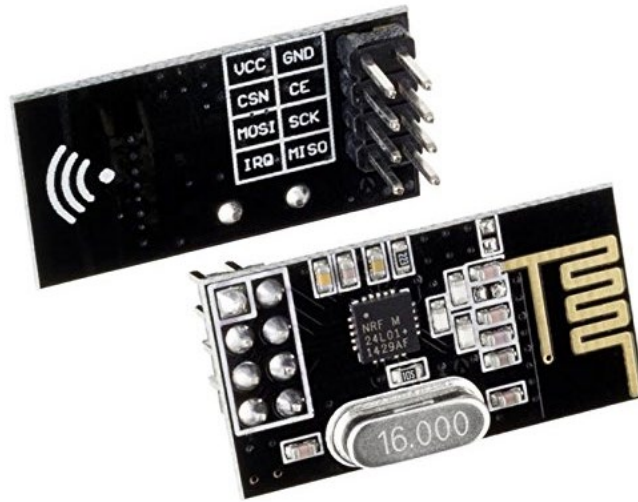

*Figure 39: nRF24L01+ 2.4GHz Wireless Transceiver*

Having an efficient RF Module is the first step in order to transmit data wireless, another very important factor that will improve the range of the transmission is choosing the correct Antenna.

## 4.5 Antennas

Antennas are electromagnetic radiators that are used to transmit to the medium, in this case, free space. The transmitter antenna will transmit a disturbance in the electromagnetic field that the receiver will receive and translate this electromagnetic wave into electrical signals. There are three main types of antennas that will describe their pattern of propagation: Omni directional, directional, semi directional.

Omni directional antennas are the ones that propagate in all directions, to visualize this easily let's think of the sun as a body that propagates evenly in all directions. Semi directional antennas are the ones that propagate in a specific angle and Directional antennas have a narrow beam that allows a very highly directional propagation.

Another very important criteria when it comes to antennas is the gain. All antennas serve to amplify the signal. The passive gain is measured in dBi which references the hypothetical lossless isotropic antenna. Some of the most important parameters in an Antenna are the power gain, Efficiency and Directivity.

Power Gain is unitless and it directly depend of the Antenna Efficiency as well as the Directivity. The efficiency it's a ratio of the Power radiated divided by the input power.

Directivity represents how the output power is directed in any direction. The most popular system of coordinates is the rectangular, polar and cylindrical. The spherical coordinate system is very popular and easier to understand since it can directly correlate the altitude



angle with theta and the azimuth angle with phi. Directivity is a ratio of the radiation intensity in a given direction divided by the mean radiation intensity. The output power is the integral of the radiation intensity in a specific direction over all the solid angles and the mean radiation intensity is the division of the power output divided by  $4\pi$  (This is because there are  $4\pi$  steradians in a sphere)

$$P_o = \int_{-\pi}^{\pi} \int_{-\pi/2}^{\pi/2} U(\theta, \phi) d\Omega = \int_{-\pi}^{\pi} \int_{-\pi/2}^{\pi/2} U(\theta, \phi) \sin \theta d\theta d\phi.$$

$$D(\theta, \phi) = \frac{U(\theta, \phi)}{\bar{U}}.$$

In the case of an isotropic antenna which as explain before radiates in all directions the directivity will be 1.

The gain of the antenna in a specific direction takes directivity into account. This will be the directivity divided by  $P_{in}/4\pi$ . It is important to understand that the only the only difference between gain and directivity in any direction is a constant which is the Antenna Efficiency, therefore here another fundamental equation in the analysis of antenna is given

$$G = E_{antenna} \cdot D.$$

The impedance matching between an Antenna and the transmission line is a very important concept in electromagnetism. As the goal is to be able to transmit all the power and have the less of reflected power into the system. Antenna Impedance is just the ratio between the voltage and the current at the input of the antenna. If the impedance of the transmission line is not match to the impedance of the Antenna, then little power will be transmitted and received by the antenna. Part of the analysis to obtain a match network is to calculate the reflection coefficient. This coefficient can be obtained by subtracting the antenna input impedance with the characteristic impedance of the Antenna and dividing this by the addition of these two impedances. This will tell us how much is reflected from the antenna to the network.

Most Antenna designers tend to pay more attention the Voltage Standing Wave Ratio (SWR or VSWR), this describes the power reflected from the Antenna. This is the ratio between the maximum voltage and minimum voltage at the transmission line. The rule of thumb most designer fall is to obtain a VSWR less than 2. The VSWR can also be obtained by using the reflection coefficient, meaning 1 plus Reflection coefficient divided by 1 minus reflection coefficient. Any VSWR less than 2 describes an antenna that reflects less than 10% of the power. It is important to understand that this is not a linear function therefore a VSWR of 4 will not mean that the power reflected is 20% but it is 36%, making this a very poor design. Below a table of multiple VSWR and their power reflected. This

will be useful when researching and looking into the multiple types of antennas for the M-GU4RD.

VSWR	Reflection Coefficient	Reflected Power (%)	Reflected Power (dB)
1	0	0	-Infinity
1.5	0.2	4	-14
2	0.33	11.1	-9.55
2.5	0.429	18.4	-7.36
3	0.5	25	-6
4	0.6	36	-4.44
8	0.778	60.5	-2.18
10	0.818	66.9	-1.74
50	0.961	92.3	-0.35

Legend	
	Good
	Acceptable
	Poor

**Table 6: VSWR and Reflection Coefficient**

There are multiple techniques to obtain an accurate match network, utilizing the smith chart is a very popular and easy approach when designing the network. Note that the VSWR describes how much power is delivered to the Antenna but it does not specify how much power is transmitted by the Antenna. This VSWR determine the potential power radiation of the Antenna, there are other measurements that need to be taken to determine how much power is radiated by the Antenna.

As explain before the length of the antenna will vary with the frequency of operation. This can be explained by using the following equation: Frequency \* wavelength = Speed of Light. Since the speed of light is constant as the frequency increases the wavelength should decrease and vice versa. There are two main types of antennas analyzed in this project. Half-wave antenna and quarter-wave antenna since these two are the most popular used in RF modules.

Half-wave dipole antennas are probably the most used and simple antennas for radio and telecommunications. This antenna consists in two quarter wavelength antennas that when placed together add to a half wave antenna. The radiation pattern of this antennas is known as the “doughnut” pattern. This is because these antennas are omnidirectional in the plane perpendicular to the axis but zero on the axis.

Quarter-wave antennas are used in almost all frequencies these bands will include Low Frequencies (LF), Mid Frequencies (MF), High Frequencies (HF), Very High Frequencies (VHF) and even beyond. The basic quarter wavelength vertical antenna is a simple design. This antenna is a “un balanced” antenna having only one connection and ground. The voltage and current waveforms show the voltage is maximum at its end and minimum at the base, therefore the current is maximum at the base and minimum at the end. This can become an advantage which will have a minimum impedance.

Here are some antennas found while doing research for the M-GU4RD.

### **Superbat 433Mhz 3dBi Rubber Duck Antenna SMA Male for Ham Radio:**

This antenna is an omni directional “rubber duck” antenna with a coaxial sleeve that provides a 3dBi gain. Tilt and swivel SMA male connector that allows to be used vertically, at a right angle and anything in between.



*Figure 40: Superbat 433Mhz 3dBi Rubber Duck Antenna SMA Male for Ham Radio*

#### Specifications

- Frequency:433MHz
- VSWR :<=2
- Gain:3dBi
- Connector: SMA male Tilt and swivel design
- Housing: Black
- Polarization: Vertical
- Directionality: omnidirectional
- Nominal Impedance:50 ohm
- Diameter:12mm
- Length:210mm

- weight: 29g

#### **IP-65 Rated Outdoor 868 & 915 MHz Antenna with SMA Male Connector:**

This Omnidirectional antenna will cover 868 MHz and 928 MHz which are both ISM bands. This a slim antenna with dimensions of 179 mm by 7 inches long and has a SMA Male connector. Some applications for this Antenna include ISM Smart meetings, Solar inverter communications and Industrial Controls.



*Figure 41: IP-65 Rated Outdoor 868 & 915 MHz Antenna with SMA Male Connector*

#### Specifications

- Frequency: 868 – 915 MHz
- VSWR :<=2
- Gain:2dBi
- Connector: SMA male
- Housing: Black
- Polarization: Vertical
- Directionality: omnidirectional
- Nominal Impedance:50 ohm
- Diameter:10mm
- Length:179mm
- weight:10g

### **1PC 433Mhz 3dbi Omni Antenna SMA Male Straight Rubber Duck Aerial FPV RC:**

This antenna operates between 400-450 MHz and provides an excellent gain of 3 dBi with an impedance of 50 ohms.



*Figure 42: 1PC 433Mhz 3dbi Omni Antenna SMA Male Straight Rubber Duck Aerial FPV RC*

#### Specifications

- Frequency:400-450MHz
- Bandwidth:50Mhz
- Gain: 3dBi
- Polarization: vertical
- VSWR: 1.5
- Connector: SMA male straight
- Impedance: 50Ω
- Max power: 20W
- Antenna height:105mm

### **15Mhz 433Mhz 470Mhz Antenna 15dbi O-mini With Sma Male Connector:**

This is a very versatile antenna that operates with either 315, 433, and 470 MHz. The gain is very high (15 dBi) but having such a big size this might be a problem for the design. All these parameters will be taken in consideration when deciding what Antenna the M-GU4RD will have. It is also important to note that some of the previous RF Modules come with an Antenna already attach. Some of this antennas already installed in the previous RF Modules are similar to the performance shown in all these other antennas.

### Specifications

- Frequency:315 433 470MHz
- Gain:15dbi
- VSWR:<1.8
- Impedance:50Ω
- Length:22cm
- Antenna Connector:SMA Male
- Cable type ;Sma female to Ufi./ipx
- Cable type:RF1.13
- Cable length:15cm



*Figure 43: 15Mhz 433Mhz 470Mhz Antenna 15dbi O-mini With Sma Male Connector*

## **4.6 Selection of RF Module**

After doing the research three modules seemed more appropriate for this design. The first module took in consideration was the 433 MHz RF Module which seemed to be the most popular, cost effective and simple to implement. The 433 MHz main advantage over the other modules was how much cost effective this is compared to the other two but, when comparing performance this module was far behind the others, according to the datasheet for the “SMAKN® 433 MHz RF Transmitter and Receiver link kit” the transmission range is less than 500m line-of-sight. This range seems reasonable but when taking in consideration all the interference that these transmitter and receiver will have when operating around buildings the range will diminish radically, some users seem complain to have a range that limits to 10-30 meters which for some applications would be good but, for this design the range must exceed much more due to the criticality of the data that is being transmitted. An approach to improve the range of this module is to add an Antenna. Some of these Antennas vary in price having an approximate of \$6. Some of these were presented as part of the design components for the RF Communications. They could

increase the range of this module but, then the cost of the RF module will increase contradicting the best feature of the 433 MHz Transmitter and Receiver which is how cost effective they are by having a cost of approximate \$7.00.

The second option taken in consideration was the “APC 220 Wireless RF Module” This module operating frequency is between 418-455 MHz with a 433 MHz default operating frequency, in other words, same operating frequency as the 433 MHz but, the main advantage of this module is the very broad range this module has. The APC 220 has a range of 1000 meters open space (line-of-sight) which more than twice as much compared to the SMAKN® 433 MHz RF module. One of the concerns with this module was the cost of it. This module costs approximate \$35.00 which is at least 4 times more expensive than the previous module presented. The APC 200 has a very good reputation amongst the RF Modules due to their reliability, large range and easy implementation. One of the reasons for such high reliability is the high efficiency forward error correction which results as well as low interference and sensitivity. Another great feature of that it comes with an Antenna, which compared to the 433 MHz that will have to add the price of the Antenna this will be something taken in consideration already. The amount of data this module transmits it also appropriate for the M-GU4RD, by transmitting approximate 9.6 Kbps. Lastly, it is important to observe the normal application for this module. The APC 220 it is normally applicable for industry purposes. This is another factor that makes this module a good fit for the M-GU4RD since they will operate in similar scenarios. This module seems to be the most appropriate for the M-GUARD design although the cost of it is elevated compared to other modules.

Lastly, the third module taken in consideration was the “nRF24L01+ 2.4GHz Wireless Transceiver” this module operates between 2.4- 2.5 GHz band. This is also a ISM band and as mentioned before Wi-Fi operates in this frequency as well. The protocol to program this design it is relatively easy utilizing a Serial Peripheral Interface (SPI). One of the main advantages of this module is how power efficient this is, the voltage ranges between 1.9-3.6V which is very low compared to the 433 MHz (3-12V) and the APC 220 (3.5-5.5V). Another disadvantage of this module is the range, having a range of approximate 100 meters which much lower compared to the APC 220. There has been some improved version of this module with an added antenna that advertise this module as able to reach 1100 meters which is much superior but the implementation of this module will become much more complex according to multiple users leaving feedback. This Ultra-Low Power module has multiple applications such as wireless peripherals, remote control systems such as RC vehicles and consumer remote electronics, wireless voice transmission (VoIP), wireless sensor networks, home and commercial automation. This module seemed to be the best for the design but, while doing more research many users complain regarding the implementation and being able to obtain the 1000 meters range. This issue seems to be a common problem with this module therefore this must be taken in consideration while making a decision. Below there a table that shows some of the important features comparing these modules and finally deciding what module would be the appropriate for the M-GU4RD.

Specs\RF Module	SMAKN® 433 MHz	APC 220	nRF24L01+ 2.4GHz Wireless Transceiver
Power Consume	3V-12V	3.5-5.5V	1.9-3.6V
Air Data Transfer	<9.6 Kbps	2400 - 19200bps (9600bps default)	250kbps
Cost	\$16 (Antenna included)	\$35	\$12
Range	500m	1000m	100m
Reliability	1	3	2
Easy Implementation	3	2	1

First (Best)
Second
Third (worst)

**Table 7:** Selection of RF Module Comparison table

The color will describe the performance of the most important specifications from each module. Green will describe the best, Yellow the middle and Red the worst.

By doing this table of comparison it is clearly that the SMAKN® 433 MHz RF module is the worst in performance. Although it is the best when it comes to easy implementation due to its popularity amongst users the power consumption is quite high, and the Air Data transfer might not satisfy the amount of data required to transfer by the M-GU4RD. Another issue with the SMAKN module is the low reliability. This module has a big chance of interference due to the simplicity of the module as well as not having any type of error correction. Now, looking at the APC220 it's evident that the cost is the main concern with this module. This disadvantage can be quickly compensated with the range of this device plus the reliability of it. These two specifications are not to be taken lightly since they are crucial for the M-GU4RD. The APC 220 also falls second place in other categories. Having a relatively easy implementation software as well as very good data transfer. The



nRF24L01+ 2.4GHz Wireless Transceiver seems to have many categories as green which demonstrates the high performance of this device, not only a low power module but also relatively cheap for the overall performance. The main concern is again the low range of this device plus the difficulty when it comes to implemented and make it perform as expected according to the datasheet.

Here is where the final decision came to the nRF24L01 and the APC 220. Both RF Modules present high performance in different categories but, it comes down to what is that the M-GU4RD requires the most. For the design purposes of the M-GU4RD, minimize power is very important due to all the multiple components that require power contained within the M-GU4RD. Even thou the nRF24L01 is clearly the winner in this category, the APC 220 has still an acceptable power consumption. Secondly, when it comes to data transfer according to Italo Travi, the Software Designer, both modules will satisfy the amount of data needed to transmit wireless. Since the two categories in which the nRF24L01 is superior do not add criticality to the design these do not present a strong argument to pick it over the APC 220. The range on the other hand it is critical to the design and since the APC 220 present a much superior range as well as much easier way to implement the team started to become much more inclined the APC 220 RF Module to transmit the data wireless. The final decision was based on performance and reliability versus price, after consulting the budget for the M-GU4RD and check that the APC 220 was still within budget it was decided to go with this as the RF Module.

## **4.7 Altimeter Sensor**

An altimeter sensor is a device that measures how high above some reference point on the Earth something is. There are many types of altimeter sensors that work using different principles. The atmospheric pressure varies with altitude on Earth. The higher up in the atmosphere, the lower the atmospheric pressure, which makes sense since there is less atmosphere weighing down at higher points. The barometric or pressure altimeter sensor is a very common one used in devices. It measures the pressure outside and calculates how high above a reference point on Earth you are, typically sea level is used as the reference point. These sensors can provide accurate information, however, variations in pressure are not always due to a change in altitude, so a change in the weather in the area could give false readings. Different methods were experimented with to avoid having unreliable information due to weather effects. One such method is the use of sound waves. The sonic altimeter sends several high frequency sound waves down to the Earth's surface to calculate the distance above the ground.

Even better, the radar altimeter utilizes radio waves to directly calculate how far above the Earth the device is. The sonic and radar altimeters are typically used in aircraft and have great accuracy. For the purpose of this project, barometric altimeter sensors will be examined for the simple nature of the method in which they calculate altitude. However, good reliability of a barometric altimeter sensor within buildings is not guaranteed. The reason for this is that many factors may affect the pressure readings in the sensor, and thus give misleading readings for altitude.

The purpose of an altimeter sensor in the M-GU4RD is to provide monitoring on the elevation of the first responder using the device. In general it may be important to know which floor the first responder is on in a building. The GPS would be able to give lateral position (position projected onto Earth's surface), and the altimeter would provide the missing third dimension to fully monitor the person's location in space. If a first responder had an issue, this final piece of information would be crucial in being able to determine where the person is, allowing for someone to get to them in as fast a time as possible. Some GPS devices have a similar function to altitude detection using a third z-axis which can be used as a way to determine which floor a person can be located. If this is the case with the GPS the team chooses to use this would eliminate the need for an altimeter.



*Figure 44: MS5607 Altimeter Module*

#### **4.8 Power Control Unit (PCU) Selection**

The purpose of the Power Control Unit, or PCU, is to provide the necessary power to run all the components of the M-GU4RD. The PCU will need to be able to last at least 6 hours of run time and power all of the sensors that will be used, including the heart rate, respiratory rate, body temperature, and GPS sensors. The PCU will also need to be able to power up the microprocessor and microcontroller.

One of the main aspects of the PCU that will be considered is the efficiency. It is crucial to have a power source that is efficient, because the quality of a system is better if it is less wasteful. The battery that will be the source of power can only be charged so much. It is important that this stored energy is used appropriately to provide for a longer run time of the device as a whole. The PCU must be able to deliver the appropriate amount of power for each sensor and the microcontroller. Regulated voltages are ideal for each device so that when or if a device needs to draw more or less current, which would be the case for device that may be idling, used intermittently, or utilizing power saving modes. This is

important, because typically a voltage will drop if more current is drawn from the supply, but a regulated output maintains the proper voltage for a large range of currents drawn.

The main component to the PCU is the power supply. Since this device will need to be portable, the power source must be along the lines of a rechargeable battery. Nowadays for most products that are rechargeable utilize lithium ion batteries. When discharging, lithium ions travel from one electrode to another. When the battery is recharged, the lithium ions go back to the original electrode, so they can make the trip again while discharging. Lithium ion batteries are growing in popularity in a variety of products due to its rechargeability and high energy density.

There are many different types of lithium ion batteries that have different advantages and disadvantages. Some batteries use lithium cobalt oxide which has a higher energy density. For a given cell size a lithium cobalt oxide battery can store more energy to be used in electronics than other batteries. Though it excels in storing more energy for its size, it comes with more safety risks. Lithium ion batteries are composed of flammable chemicals, and lithium cobalt oxide ones are more prone to catching fire or exploding. This phenomenon is best demonstrated with Samsung's Note 7 that had an issue of batteries exploding randomly or while charging. These lithium cobalt oxide batteries are typically used for smartphones. Lithium ion batteries of different elements can have a lower energy density, but increased safety and longer lifetime. An issue with lithium ion batteries is battery life. The battery can be charged a few hundred times depending on the battery before the battery starts to wear out. The battery can also be drained if not used or charged regularly. These types of batteries are used for medical equipment and electric tools, since they are safer.

Lithium ion batteries come in various shapes. Common lithium ion batteries are cylindrical in shape, but the ones used in smartphones are flat and rectangular. These smartphone batteries are known as pouch batteries and are referred as lithium polymer batteries. Depending on the packaging of the whole product, a cylindrical battery or a pouch battery would be more advantageous.

Since a printable circuit board (PCB) is required in our design the PCU and its various connections to all microcontrollers, microprocessors, and biometric sensors will be placed on a PCB.

#### **4.8.1 Changes Made in Senior Design 2**

After developing the M-GU4RD the group decided the overall design for the power distribution would include a 7.2V lithium ion battery pack that will go through a buck converter to regulate at 5V for all the devices to run. Also included in the power section of the PCB was the charging circuit that will allow for the user to recharge the lithium ion batteries. The original design utilized a 3.7V battery as a power source that stepped up to 5V using a TI boost converter for all the devices to be powered. In the final design, the power source used was two 3.7V batteries connected in series to achieve 7.2V. This voltage was then stepped down with the LM2576ADJ adjustable buck converter to 5V. There were

many reasons for this change in design. The initial change was because during the development, the boost converter failed to output 5V from the battery source. The team would have attempted to use another boost converter, but breadboard testing with boost converters is nearly impossible since the appropriate boost converters are very small surface mount devices. The only way to test these boost converters is to design the circuit on the PCB. Doing this would have been a very expensive approach and would prolong the completion of the project. Instead the time chose to use a buck converter because there are many through hole versions of the buck converters that can be easily implemented on a breadboard. Therefore, the buck converter can be tested before implementation on the PCB. This advantage made the development and testing cheaper and faster. Some other benefits to this design include the fact that the team was more familiar with using buck converters, and some team members had different buck converters on hand to test.

## 4.9 Display Selection (GUI)

Since the M-GU4RD is designed to send information to an outside display there are a few options available to the team:

- An application can be made that is accessible by any Wi-Fi enabled device (laptop, desktop, and phone).
- A peripheral device can be made with direct access to the M-GU4RD (i.e. a touchscreen display connected to a microprocessor)

In either case it would be easier if an application was made to house the GUI.

This application would be developed using either JAVA or Python for the convenience of the group. There are available libraries that will allow us to integrate many of the features that the board is capable of showing and integrate it with the sensors of M-GU4RD. This application will calculate and show readable data so that any user will be able to understand what these readings and signals mean. There will be color coded and built based on the main principles of UI design.

Some of the principles we will implement our UI design on are the following:

### Clarity:

This is a key principle that the user must be able to have as soon as they open the app. Clarity goes side-by-side with simplicity. In other words, if the design is simple enough to understand and comprehend their functionality or ‘what will happen if they select one option or the other’ then that means that we have met this principle and most importantly have accomplished a very user-friendly application design.

### Flexibility:

This is the second most important principle there is and that we would use in our implementation. Flexibility in UI design refers to ‘designing something that looks good in all situations.’ In other words, our application must be consistent but flexible at the same time. It must have a very responsive layout; for multiple platform resolutions without

making the user's eye sore with confusing and ugly blocks that do not fit, clear and readable data and easy to understand charts and or graphics.

### Familiarity:

When it comes to a good UI design for an application that must be used in critical conditions, such the ones first responders face on a daily basis. Familiarity is a key principle that should be implemented. Familiarity refers to the simple fact that if we are used to certain things operating in certain ways, it will be familiar to us and hence a lot easier to use. This mainly refers to things like icons, buttons, navigation and common color codes.

### Efficiency:

First responders need things to happen fast and efficiently. This is where this principle comes into play. It states that the application and UI should complete tasks fast and in the most efficient way, without sacrificing the application results or accuracy.

### Consistency and Structure:

This is another important principle that drives how our application must look and feel. Consistency throughout the entire application will guarantee that the user will not get lost or confuse when navigating from one screen to another. Hence, improving the accuracy and speed with which the user utilizes the app. Furthermore, having a well round structure will make the application simple to understand overall, this could be useful for training purposes and when doing an overview of the app and its functionalities.

## 4.9.1 Changes Made in Senior Design 2

During senior design 2 the team developed what the GUI will look like in more detail. The image below shows what the final GUI design is. The interface shows the user's heart rate, respiration rate, temperature, and status. On the right-hand side of the app the GPS location is displayed. For future development there are tabs for every M-GU4RD user, so the person monitoring the first responders can view the vitals and locations of several users at once. This app currently is available for android devices.

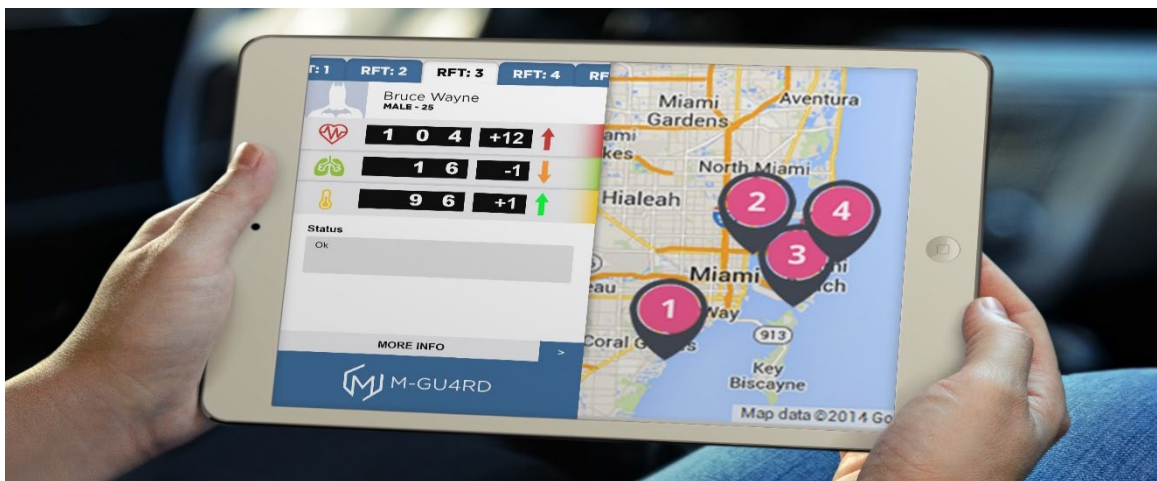

*Figure 45: Finalized GUI*

## 4.10 Additional Component Selection

The parts included in this section are circumstantial as they depend on the devices the team selects. For example, not all GPS units include an antenna and microprocessors need an analog-to-digital convertor if the sensors are going to be directly attached to it. Some devices on this list are also either recommended or were considered in the design process.

### Raspberry Pi MCP3008 Analog-to-Digital Converter:

Since the Raspberry Pi is one of our team's top contenders for the brain of the M-GU4RD an analog to digital converter is necessary. Unlike development boards like the Arduino Uno there are no analog I/O pins on a Raspberry Pi. The sensors being used to monitor vitals need to be processed digitally to make sense of their calculations. This converter solves for this shortcoming in the microprocessor for only \$5. Without this device none of the analog devices can be used properly.

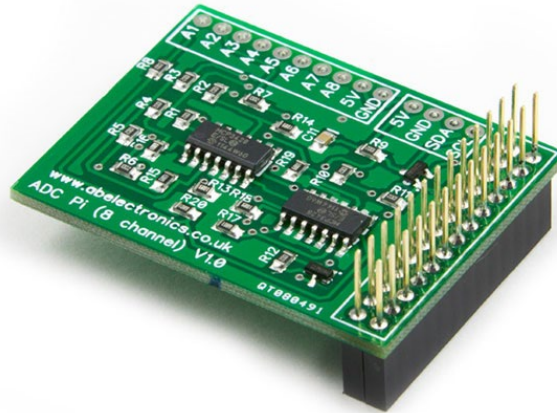

*Figure 46: Raspberry Pi ADC Chip*



*Figure 47: GPS Embedded Antenna SMA*



### **GPS Embedded Antenna SMA:**

For the GPS modules that do not include an antenna, an external antenna will also be needed. This antenna is \$11.95 and comes with an SMA connector. The power consumption is 3.3V and 12mA. This antenna would suffice for the M-GU4RD application.

### **Raspberry Pi 433 MHz Set:**

A set containing a transmitter and receiver that projects a 433 MHz radio signal. It is cheaply priced at \$2-\$3. This is perfect for coding commands and responding to the coded task as soon as the receiver receives a transmission. The main concern with this device is whether enough data is being sent and how far the transmitter and receiver can be in respect to each other. Our final device must be capable of sending and receiving information from a respectable radius, but this device appears to only operate at a smaller range. In addition, 433 MHz may not be able to send the information we need as we have several sensors and components with information to send to the graphical user interface (GUI). This is also compatible with the Raspberry Pi which is one of the better options the team is looking towards as the main microprocessor of the M-GU4RD.

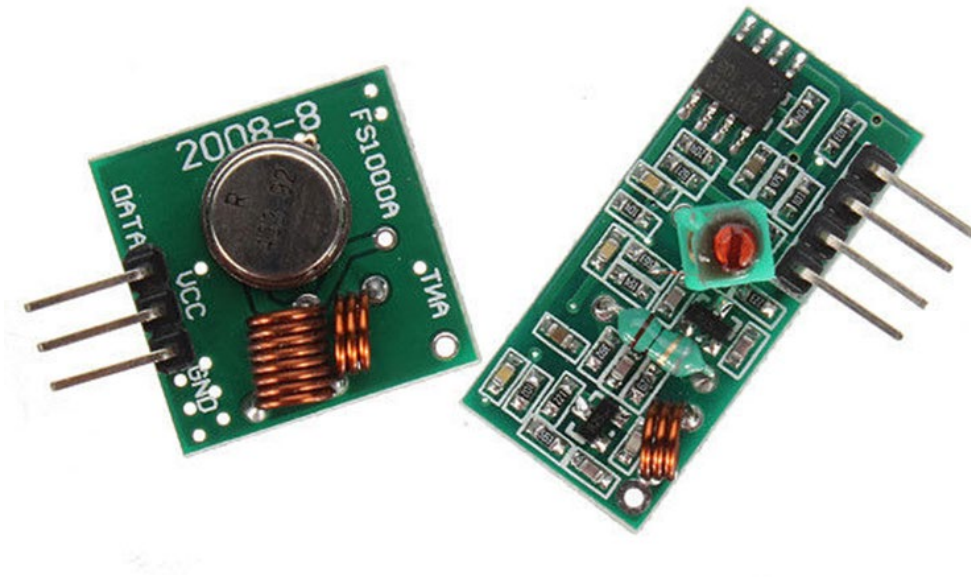

*Figure 48: Raspberry Pi 433MHz Transmitter & Receiver*

### **Raspberry Pi 2.4 GHz NRF24L01+ Module:**

This device is a receiver/transmitter capable of sending large amounts of information at a 2.4 GHz signal. It is a better alternative to the 433 MHz set as it can send large packets of information as well as commands simultaneously. It costs \$3-\$4 for one device which is slightly more expensive but still relatively cheap. With this device we have the range and data capability to send all the relevant sensor and GPS information to the graphical user interface. This device is also compatible with both the Raspberry Pi and Arduino.

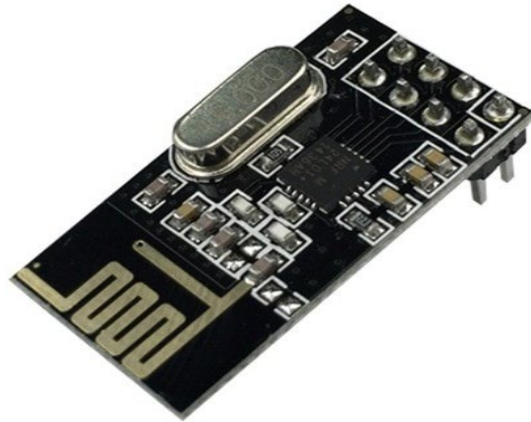

*Figure 49: Raspberry Pi 2.4GHz NRF24L01+ Module Transmitter/Receiver*

#### **4.11 Final Components Selection**

After careful consideration and review of all the components and based on our table comparisons, we proceeded to order the main components that will be used for the design and implementation of M-GU4RD.

Components Summary:

- Raspberry Pi 3B (Micro Computer SOC)
- Arduino Uno (Auxiliary Microcontroller)
- ADS1292R ECG/Respiration Shield
- APC-220 Wireless Transceiver
- NEO-6M GPS Module
- DS18B20 Digital Temperature Sensors

The initial testing and integration results of the deliverables and requirement specification will be based on these main components. Initial testing will be performed and the results and constrains will be listed in this section of the paper. The following figure shows all the main components that will run the core features of our project.



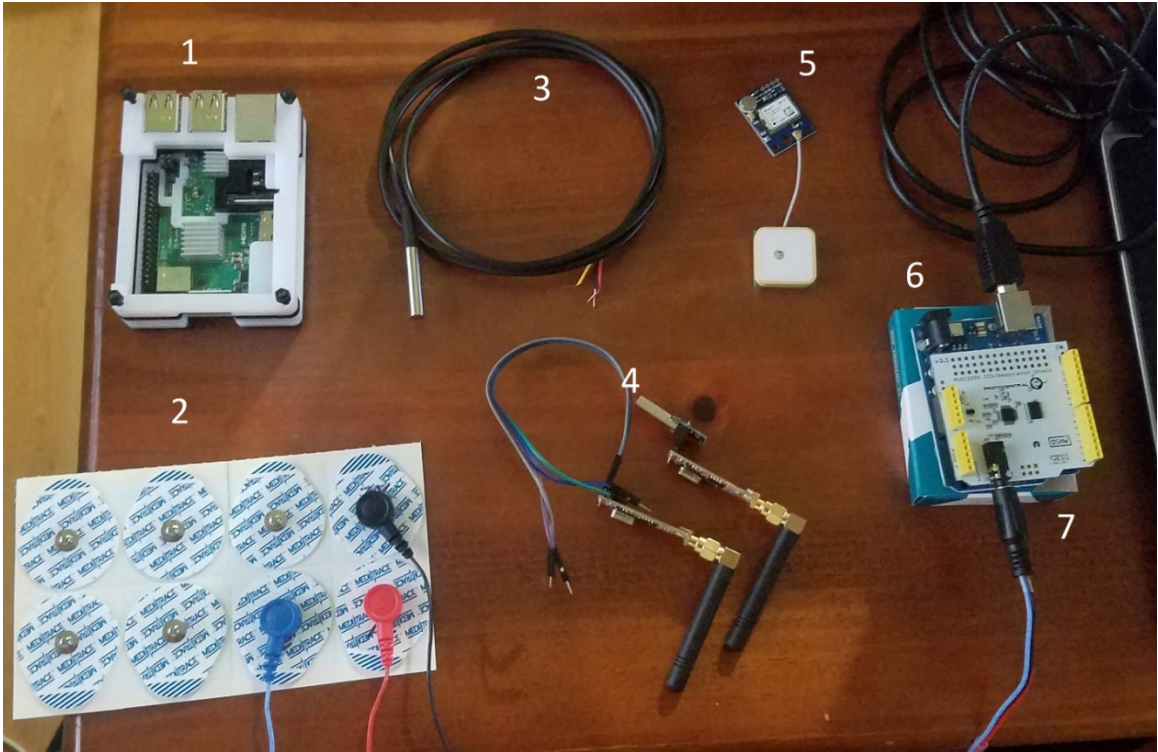

**Figure 50:** Core Components of M-GU4RD

Number	Component
1	Raspberry Pi
2	ECG Electrodes
3	DS18B20 - Temperature Sensor
4	APC 220 - RF Module
5	NEO-6M - GPS Module
6	Arduino UNO
7	ADS1292R - ECG/Respiration Shield

**Table 8:** Core Components of M-GU4RD

## 5.0 Design Constraints & Standards

- Must weigh less than 7.5 pounds
- Will be smaller than 20cm×20cm×15cm.
- Will be able to alert about high levels of present gasses such as CO<sub>2</sub>
- The battery of the device should last longer than 6 hours.
- The values obtained from the readings of the sensors should be within an 8% margin of error.
- Will be portable
- Must not interfere with other necessary technology needed by the user
- Will be durable and reliable
- Must be easily attachable and allow for free movement of the firefighter. Install time should be less than 60 seconds.

### 5.1 Development Constraints

When designing the M-GU4RD it is a must to include a printable circuit board (PCB). While the team's design did not necessarily need a PCB it is still a requirement that must be addressed. To solve this dilemma the team has decided to create the power control unit (PCU) on the PCB to ensure this requirement is met. Another constraint entailed that the team employs a substantial amount of work as to gain experience in constructing their device. This problem was addressed by rejecting the idea of using medical development boards which eliminated the search of sensors and some even included working GUIs. Instead the team chose to use basic microcontrollers and microprocessors to increase flexibility and create a unique design.

Aside from the constraints above that were assigned, the team established a list of constraints that the M-GU4RD must meet:

- Biometric sensors (ECG & body temperature) must prioritize accuracy and durability over size
- Device must be as compact and small as possible, but not compromise the accuracy of the device
- Device must maintain flexibility as sensors can vary in sizes and additional features can be added
- The fabricated device must be ergonomic and form to the body without irritation
- Device components must be as cheap as possible, but not sacrifice performance

These constraints were constructed with utility in mind as the team wants the device to be cheap and usable for all first-responders to use in real situations whether it be fighting fires, diagnosing the injured, or in the line of fire.

In addition to these device constraints are the constraints due to the experience and skill of the team members. For the sake of constructing the M-GU4RD the team is limited to these skills:

- Software programming must be in C, Java, Python, or an assembly language

- Team is familiar with using Raspberry Pi, Arduino Uno, and MSP430
- Team is familiar with electrical networking, wireless communication, and software application
- Limited knowledge in biometric sensors and GPS units

Fortunately, these constraints serve more as strengths because the M-GU4RD device will not require much more knowledge in electrical and computer engineering. The biggest constraint would be using hardware that is only programmable in a language the team is unfamiliar with or using a device in general that the team is unfamiliar with. With a bit of research these issues can be resolved. As for gathering information on sensors this will require more intensive research into the medical field and how they are utilized.

## **5.2 Health Insurance Portability & Accountability Act (HIPAA)**

Signed into law by President Bill Clinton on August 21, 1996 the Health Insurance Portability & Accountability Act deals in data privacy in regards to information collected and stored using medical devices. This applies to all electronic devices that can record medical information and involves providing proper safeguards regarding its data. HIPAA also acts as the mainframe for standards and regulations that healthcare and insurance providers must abide by.

The M-GU4RD the team is developing is a portable instrument that reads vitals through biometric sensors and sends it to a peripheral device that interprets and displays the information. HIPAA is an important standard to meet as the team's device records information that is displayed onto a screen. To abide by these rules, the M-GU4RD does not save the information received from the sensors. It only displays the current biometric levels and its fluctuations, trashing any previous medical information. In addition, precautions will be made to protect any information during transit between devices.

HIPAA consists of five sections/titles:

### **Title I: HIPAA Health Insurance Reform**

Protects those needing health insurance from being denied due to specific illnesses or disease in addition to having limits set upon them involving lifetime coverage. Also ensures health coverage to those who lose or change jobs.

### **Title II: HIPAA Administrative Simplification**

Establishes the US Department of Health & Human Services (HHS) as the head of standards for electronic processing of medical information. Healthcare organizations must comply with the HHS and provide secure access to health information. In terms of complying to HIPAA guidelines, this title is the most important as it specifies requirements and standards that must be met in order to reach "HIPAA Compliance". These standards include:

- National Provider Identifier Standard - All health entities including personale and healthcare providers must have a 10 digit number identifying them
- Transactions and Code Sets Standard - A standardized mechanism must be put in place electronic data interchange (EDI)
- HIPAA Privacy Rule - The standard for protection of private information concerning a person's medical data
- HIPAA Security Rule - The standard for using security protocols in order to protect electronic information regarding a person's medical data
- HIPAA Enforcement Rule - Rules regarding the actions taken against HIPAA compliance violators

### **Title III: HIPAA Tax-Related Health Provisions**

Holds all tax related guidelines involving medical care.

### **Title IV: Application and Enforcement of Group Health Plan Requirements**

A more intensive look into Title I and the details of health insurance reform. Focuses primarily on continued health coverage and those with pre-existing illnesses, diseases, and conditions.

### **Title V: Revenue Offsets**

Deals with company owned insurance and regulations. Also addresses the treatment of those who lose US citizenship.

### **Health Information Protected by HIPAA:**

- Name, address, birth date and Social Security number
- Current physical or mental health condition
- Any form of healthcare provided
- Information regarding payment methods or other documentation that can be used to trace the identity of a person

### **Administrative Requirements to Ensure Privacy:**

- An official must be appointed to establish and implement rules to endorse privacy protection
- Employees must be trained to follow the procedures made by the privacy official
- All safeguarding assets created to maintain privacy must be sustained and monitored
- A process must be put in place to receive complaints regarding privacy policies and procedures that can be addressed
- If a person's identity and information are disclosed the organization is to aid in helping those involved

## 5.3 Limitation in RF Module

One of the main concerns when developing the M-GU4RD was to have enough of a range to transmit the data wireless. This feature was crucial when deciding which RF Module was going to be chosen for the design. When reading multiple datasheets, the range was always presented as either “open space” or “open space” which means this does not take in consideration the multiple losses created by any type of obstruction. In a practical scenario, the range provided by the datasheets does not provide a useful information for this design since the typical scenario in which the M-GU4RD will perform has multiple obstruction such as walls, windows, either any trees in some other scenarios. Here is where understanding what limits the RF range will help to optimize the performance of the M-GU4RD.

### 5.3.1 Range and Frequency

As mention before walls will be the first concern that comes to mind when thinking of factors that contribute to the losses of the transmit wireless data is the walls that will be between the receiver and the transmitter. Here is where is important to know that lower frequencies can propagate further than higher frequencies this means than for example the 433 MHz will propagate much further than 2.4 GHz module given both the same modulation and output power. This is due to the relation between the wavelength and frequency, the lower the frequency the higher the wavelength and the same goes for higher frequency and small wavelength.

$$\lambda = \frac{c}{f}$$

There are also other factors that influence the penetration of this electromagnetic waves such as the concept known as “Skin depth ( $\delta$ )” which describes the penetration depth of the electromagnetic wave. This equation also takes in consideration the dielectric as well as the permittivity of the material and the frequency of the wave giving an inverse relationship with the frequency proofing that as the frequency increases the Skin depth will decrease having a more reflected wave. While having a further range with lower frequencies other factors are taken in consideration such as the size of the antenna. As the frequency increases the size of the antenna should increase as well therefore a higher frequency module will probably have a smaller antenna. Also, the higher the frequency the broader the bandwidth. Therefore, depending on the amount of information that need to be sent the frequency does play a big role in the corresponding bandwidth.

$$\delta = \sqrt{\frac{2}{\omega\mu\sigma}}$$

Path loss is another reduction to consider. This refers to the reduction in power density that occurs as the waves travel. To simply understand where this come from let’s picture two antennas, one is sending power and the other receiving. For simplicity both of these antennas have an isotropic pattern and as some of the power transmitted is receiver the

following equation can be used as valid Power Receiver ( $P_r$ ) is less than the power transmitted. Now, going back to the definition of the Path loss which is described as the reduction in power density of an electromagnetic wave as this propagates. Let's take the equation for the Power receiver and see how this relates to the Path Loss.

$$P_r = \frac{P_t G_t G_r \lambda^2}{(4\pi R)^2}$$

Where,

$P_r$  = Power at the receiving antenna

$P_t$  = Output power of transmitting antenna

$G_t$  = Gain of the transmitting antenna

$G_r$  = Gain of the receiving antenna

$\lambda$  = Wavelength

$R$  = Distance between the antennas

If utilizing isotropic antennas, the linear gain equals one therefore,  $G_t$  and  $G_r$  are both 1. Therefore, the component multiplying the  $P_t$  is what is representing the loss in the power. Now by utilizing the definition once again the ratio between the power transmitted divided by the power received this will give the path loss in free space as

$$\text{FSPL} = \left( \frac{4\pi d}{\lambda} \right)^2$$

This Path Loss it can easily be explain in Free-Space although in the real world there many other factors that can contribute to the degrade of the range such as the obstacles or losses due materials, humidity in the air and metal objects which will reflect the radio waves, these waves can be reach by the receiver creating distortion and sometimes even canceling the signal.

### 5.3.2 Antenna High and Fresnel Zone

Although this might be a factor that is out of control for the M-GU4RD it is good to understand how the height and the Fresnel Zone affect the range of the transmission. First of all, by placing the transmitter and receiver in a higher height this results as diminishing the number of obstacles in the way such as cars, trees, or other people. Secondly, by doing this, it helps to at least 60% clear of the Fresnel zone.

The Fresnel zone is an elliptical shape body around the direct line of sight between a Receiver and Transmitter. Any obstacle in the way of the Fresnel zone will weaken the transmitted signal and sometimes even cancel the transmitted signal. The maximum radius

of the Fresnel Zone is located exactly at the middle of the transmission. As a rule of thumb there should be no obstacles in the Fresnel zone although this seems to be unpractical a maximum of 40% blockage it is allow. Anything more than this will result as a significant signal loss. The Fresnel zone also takes in consideration the curvature of the Earth when the distance between the transmitter and receiver is significant enough. In conclusion, the height of the Antennas is very important when trying to send wireless communication through long distances.

Lastly, Noise is another factor that cannot be controlled but it needs to be taken in consideration. Since depending on the frequency selected there might other devices operating in the same frequency causing disturbance in the transmission.

### **5.3.3 FCC Constraints**

As this design will require to transmit data wireless it was important to be aware of the limitations and constraints this method of communications presents. The Federal Communications Commission known as the FCC is an independent government agency responsible for the regulation of interstate and international communications, this implies by radio, television, wire and satellite across all fifty states. The FCC was formed by the Communications Act of 1934 and establish that the creation of the FCC was "for the purpose of the national defense" and "for the purpose of promoting safety of life and property through the use of wire and radio communications. Many FCC rules regulate a limit for the amount of power of the transmitter. This is mainly determined by the Effective Isotropic Radiated Power (EIRP).

For example, in the usage of Wi-Fi the maximum transmitter output power fed into an antenna is 1000 mW. The maximum EIRP is 36 dBm which is equivalent to 4 Watts. According to the FCC. There are different constraints depending if this will radiate to one point or multiple points, but they will both have an upper limit of 1 Watt of maximum power. This will present a limitation in the selection of RF Modules since an easy way to increase the range of the device is by increasing the power transmitted. The group had to make sure that the module will fall under the regulation of the FCC for the transmitter since some devices that come from other countries will not fall under the FCC Regulations.

Lastly another wireless communication constraint when designing a wireless communication system is what frequency can this be operated. The election of the right frequency will impact not only the performance of the device but will also affect where in the world can this device be operated. This is because multiple countries have different bands allow for operations. In the case of the M-GU4RD which is being develop in the United States the election of the band will be under the FCC regulations. It is also important to notice that there are certain bands that are allowed worldwide such as 27 MHz,40 MHz,2.4 GHz and 5.8 GHz. The FCC rules can become complicated. For example, the 433 MHz is normally thought to not be available because it is considered a license frequency in the United State. Still, under part 15 of the FCC regulations if the device transmission power is low (below a certain threshold) the 433 MHz will become operative in the United States.

## **5.4 Economic and Time Constraints**

The economic factor plays a very important role when designing a project. This will represent a limitation in the selection of the components for the M-GU4RD. When looking for the best components it was important to keep in mind the budget assigned for the project. Another factor to keep in mind is that when ordering the parts, the shipping cost needs to be included. Some of these components come from other countries such as India and China, this will add the cost of the shipping if the parts are needed promptly.

This project is not sponsored therefore is fully financed by the four group members. The M-GU4RD budget is \$400.00 which is also one of the requirements for the M-GU4RD. Considering that this design will utilize two microcontrollers this will definitely present an impact in the budget. In general, the components required for this design such as the multiple sensors can be high price therefore it was very important to keep the budget in mind when selecting these components. This does not mean that the components were merely chosen because of their price since they all must meet the rest of requirements. Although the team did a great job in the part selection some more advance technology was not reachable due to its price.

As mentioned in the previous paragraphs some components were not sold in the United States. Meaning the shipping will take longer and this can delay the testing of components. Here is where time becomes a constraint. The time given to have all the researching and individual testing for components is one semester which is approximate sixteen weeks. On December 3rd the report must be submitted having all these data incorporated in it.

The second part of this project consists in the integration and ensemble of all the multiple components to create the M-GU4RD. For the second part of the project an approximate of sixteen weeks will be given. It is important to know that during this time the project must also design and manufacture a Programmable Circuit Board. In order to realistically overcome the time constraints, the group will have to have multiple plans to be able to have a successful deliverable by the end of the sixteen weeks. Lastly, the group will meet weekly to make sure the project is on schedule and if any problem arises the group will be able to adapt, correct and fix and meet the deadlines.

## **5.5 Environmental, Social and Political Constraints**

There are already multiple systems similar to the M-GU4RD to monitor vitals in the market. The social and political constraints consist in the affordability and multiple features this design provides to the user. This device will give the user the option to recharge the battery independently from the having the M-GU4RD casing attach to it. Also, provides the user the option to adapt a bigger battery for any specific application which can result in maybe reducing the overall weight of the design. Also, the circuitry of this design will be much simpler to understand for maintenance purpose or replacing of parts. The multiple differences from our design to the ones in the market will satisfy the political and social constraints.



## **5.6 Manufacturability and Sustainability Constraints**

The manufacturability limits the design by restricting the components of it to something that is possible to manufacture. In the case of the M-GU4RD, this design it is limited to the services and components available to the group members. Sustainability is another constraint since this device must be operated in very active scenarios for the first responders. Sustainability and Manufacturability can have a direct relation with each other although sometimes one must scarify one to meet the other one. For this design it is important to take both in consideration when choosing from the different types of technologies available. These constraints can be directly related to the how the design will isolate the multiple electronics and cables inside the case for a better sustainability which can result in a direct impact of the manufacturability. Also, how this case must be resistant to multiple temperatures if the first responder is a fire fighter, this is another example of how these two constraints relate to each other in the M-GU4RD design.

## **5.7 Software Standards**

The ISO/IEC/IEEE 29119 Software Testing is the international set of standards that may be implemented into any software development lifecycle or organization. There are currently five standards that are internationally recognized and agreed standards for software testing that provide any implementation or organization the ability to integrate a high-quality approach to testing that can be communicated throughout the whole world. These ISO/IEC/IEEE 29119 standards are developed by ISO/IEC JTC1/SC7 Working Group 26 and they are composed of the following:

- Concepts & Definitions
- Test Processes
- Test Documentation
- Test Techniques
- Keyword Driven Testing

The development cycle of this project will focus mainly in standards number two and three.

### **5.7.1 Test Processes**

The test processes for this standard focus on adopting a generic process model that will allow the use of a software testing procedure for any software development life cycle. The model specifies test processes that can be used to govern, manage and implement software testing in any organization, project or testing activity. The process model is based on the following three layers to undergo a good testing methodology and results.

As seen in the diagram the Test Process Model divides the testing procedures in to three layers allowing any life cycle to be adaptable and in a non-waterfall model state of testing, by doing so giving a very detailed and well-rounded approach to testing all of the functionalities and deliverables individually and altogether through the management processes and the dynamic processes.

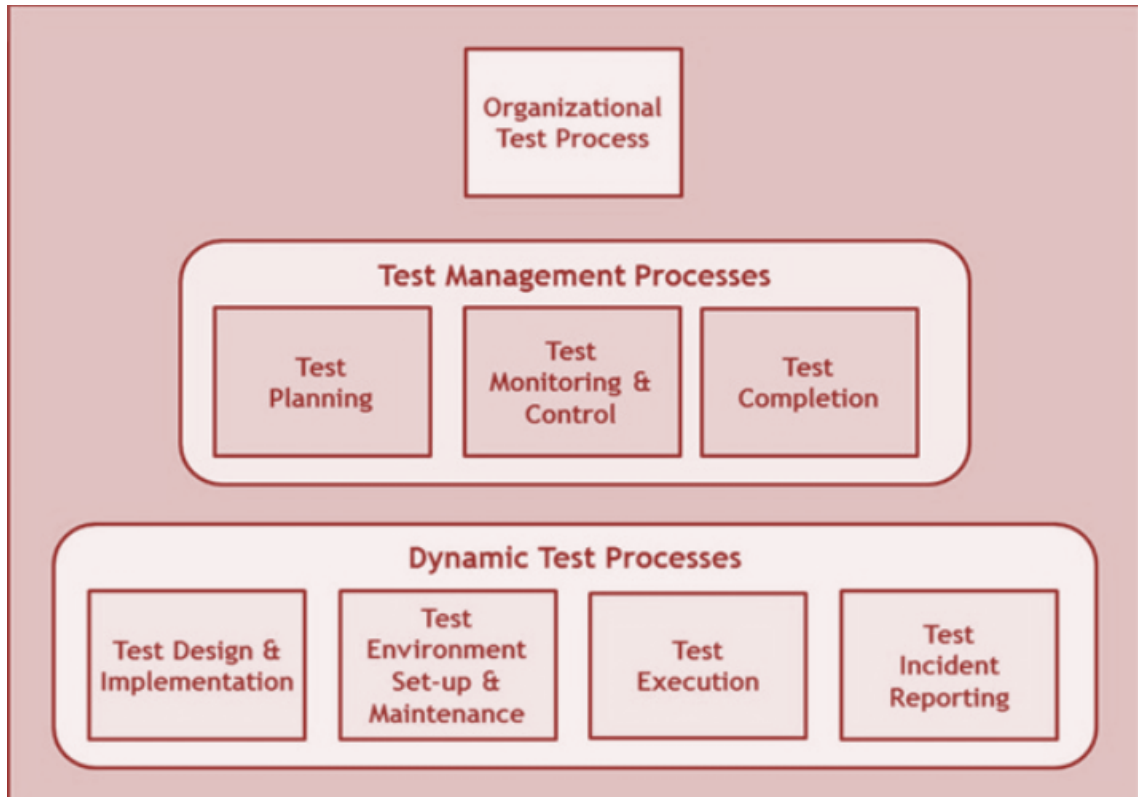

*Figure 51: Software Test Process Model*

### 5.7.2 Test Documentation

The aim of this standard is to develop and implement techniques that cover the entire software testing life cycle. Every organizations unique needs could be adapted to each template that is tailored for different purposes to support the standard's implementation within any software development life cycle model. Furthermore, all the templates align with the test process defined by the previous model in step 2 giving a clearer overview and overlapping perspective which allows us to work on a more parallel implementing a pipelining model for efficiency and error checking.

This standard was developed with the IEEE 829 Test Documentation standard as a basis, and as such it supersedes that standard with the following structure. The ISO/IEC/IEEE 29119 is broken down into three layers following the test process model as following:

#### **Organizational Test Process Documentation:**

- Test Policy
- Organizational Test Strategy

#### **Test Management Process Documentation:**

- Test Plan (including a Test Strategy)
- Test Status Report
- Test Completion Report

**Dynamic Test Process Documentation:**

- Test Design Specification
- Test Case Specification
- Test Procedure Specification
- Test Data Requirements
- Test Data Readiness Report
- Test Environment Requirements
- Test Environment Readiness Report
- Actual Results
- Test Result
- Test Execution Log
- Test Incident Report

The three main layers are then further broken down into more specific subsections that explain how to properly document our findings and processes along the way. By doing so, we are ensuring that a proper internationally-recognized standard model is utilized in the development of M-GU4RD, guaranteeing a risk-based approach testing that is best-practice for this part of the life cycle.

**5.8 Hardware Constraints & Standards**

The MCUs and hardware being utilized for M-GU4RD are products that meet all industry standards and regulations for use within the U.S. However, some of these MCUs come with some constraints that are presented in this section.

**Raspberry Pi conditions of use:**

The Raspberry Pi microcomputer which belong to the Raspberry Pi foundation does not come with any licensing or GPL that restrict us for the use of the board to specific areas or ways of use. However, this foundation is registered as a UK charitable organization under the IHTM11115 code. The general outline for this code explains that a charitable organization registered under IHTM11115 must meet the definition in the Charities Act 2006/section 2, which explains that such organization must meet a public benefit to prevent, relief or assist advance poverty and humanity overall. In conclusion, our use of the board for the project is inheritably adopting this act with the implementation of this board into a system that helps shape technology for a beneficial purpose.

**Arduino UNO conditions of use:**

Similarly, to the Raspberry Pi, the Arduino UNO comes with the Open-Source hardware principles which much like the Open-Source software principles, which will be touched in the next section, explain the unlimited possibilities of implementation for any project. These designs are licensed under the Creative Commons Attribution Share-Alike license, which allows for both personal and commercial derivative works, as long as they are credited to the Arduino family and release their designs under the same license. On the

other hand, the Arduino UNO family comes with some limitations when using their product for commercial use. These limitations are specified by Arduino as following:

- Physically embedding an Arduino board inside a commercial product does not require you to disclose or open-source any information about its design.
- Deriving the design of a commercial product from the Eagle files for an Arduino board requires you to release the modified files under the same Creative Commons Attribution Share-Alike license. You may manufacture and sell the resulting product.
- Using the Arduino core and libraries for the firmware of a commercial product does not require you to release the source code for the firmware. The LGPL does, however, require you to make available object files that allow for the relinking of the firmware against updated versions of the Arduino core and libraries. Any modifications to the core and libraries must be released under the LGPL.
- The source code for the Arduino environment is covered by the GPL, which requires any modifications to be open-sourced under the same license. It does not prevent the sale of derivative software or its inclusion in commercial products.

## 5.9 Programming Language Standards

During the development of M-GU4RD the project will be developed and adapted in multiple programming languages which have some standards and some out-of-the-box software regulations that we need to keep in consideration. The Raspberry Pi and Arduino Uno families are presented with similar software licensing. Both boards can relate to the OpenCL (Open Computing Language) framework for writing programs that execute across platforms, and these are licensed common licenses such GPL, LGPL and modified BSD. The software and programming languages for the specific boards and modules will be discussed in the following diagram:

MCU	Software and OS	Programming Languages
Raspberry Pi A+	Raspbian 8.0	Scratch, Python, Java,C,C++,Perl,Erlang
Arduino UNO	Arduino IDE 1.8.7	C,C++

*Figure 52: MCU Software & Language*

After careful research on functionality and compatibility for both the MCU boards and the additional module sensors that need to be implemented for M-GU4RD, the main

programming languages that were selected were “Python” for the programmability of the Raspberry Pi and the RF communication systems, and “C language” for implementing the sensor modules and the calibration of the input data through the Arduino IDE.

Under ISO/IEC 9899 the C standard is an International Standard which specified the interpretation of programs written in the C programming language. As with the OpenCL, the ISO/IEC 9899 specifies the syntax and constraints of the C language that will either affect or assist for the elaboration of the software running on M-GU4RD. This standard will adhere to the input, output, and data-processing of the software for the sensors before transmission. Furthermore, the Python standard library will be implemented to include the basic syntax and semantics of the Python language as well. The Python library contains built-in modules that provide access to different system functionality such as file I/O, and other standardized solutions to problems that we might face during the development of the software. Additionally, we would need to incorporate the use of some pre-defined libraries that were tailored specifically for the use of each separate module. Some of the libraries used to enable full functionality and most accurate readings from each module are presented below:

- Arduino DallasTemperature library
- Arduino OneWire Temperature library
- Arduino Protocentral ADS1292R library (Respiratory and Heartrate testing)
- Arduino TyniGPSPlus library (GPS Testins)
- Raspberyy RF-TrulyMagical software (RF Testing)

### **Design Impact of Programming Languages:**

The impact of which programming languages are used for this project is very important. The accuracy needed to be interpreted from the inputs to be processed and delivered back need to be with a very low margin of error. Due to the severity of dealing high sensitive data that could mean life or death for the user, the C programming standard and Python standards need to be studied as well as tested to the maximum, in order to avoid common coding errors or data processing errors due to faulty libraries or coding strategies previously unknown to the designer(s) and coder(s). Throughout the paper we discuss the different Health Insurance Portability and Accountability Act standards necessary for the system we are developing. Furthermore, the software and code handling this important data and information shall encompass the methods and protocols for the collection, exchange, storage and retrieval of this sensitive data. In order to do so, the code needs to be written in an impeccable manner and with added security measurements such as “Checksum verification”, “Bit parity checking”, and encryption algorithms that will ultimately ensure the authenticity, integrity and origin of the data.

### **5.10 Battery Standards**

This standard talks about the required tests that are necessary for testing lithium batteries. The standard describes the eight tests that are need to fully test a lithium battery by standards. The tests are as follows:

- Test 1 - altitude simulation
  - This test emulates the scenario of an unpressurized airplane cabin when at an altitude of 15,000 feet.
- Test 2 - thermal test
  - This test examines the battery in extreme temperatures from -40 degrees Celsius and 75 degrees Celsius. The battery is placed in a -40 degree Celsius environment for 6 hours, then 75 degrees for 6 hours. This is repeated 10 times.
- Test 3 - vibration test
  - This test reproduces the vibrations associated with travelling in a vehicle.
- Test 4 - shock test
  - This test reproduces the vibrations associated with travelling in a vehicle as well.
- Test 5 - external short circuit test
  - This test places a resistance of less than 0.1 Ohm to short the battery terminals. The battery passes if the battery does not get higher than 170 degrees Celsius, gets ruptured, or catches on fire.
- Test 6 - impact test
  - This test simulates the casing of the battery by applying a force to it.
- Test 7 - overcharge test
  - This test overcharges the battery with twice the recommended charging current. The battery is checked for the next week to ensure nothing has been damaged.
- Test 8 - forced discharge test
  - The battery is discharged forcibly for this test.

This standard is relevant to the M-GU4RD project because a lithium ion polymer battery will be the power source for the device, and it is important to understand what testing is required for the battery. By being aware of the testing that took place for the battery, the users will be more aware of what the battery is capable of and ensured of the battery's safety.

## 6.0 Project Design

To construct the M-GU4RD it is necessary to design an approach for both the hardware and software. In this section the team outlines the components being used, why they were chosen, how they will be used, and the overall design and execution of the M-GU4RD.

### 6.1 Hardware Design

The finalized technological design for the M-GU4RD will consist of two separate devices:

- The actual M-GU4RD device that is worn on the body
- A receiving device that holds the GUI

The M-GU4RD will be strapped to the body of the first responder to improve accuracy of the ECG sensors, which will be attached to the user's upper-body. While all electrodes will be attached to the user's upper-body the microcontroller and microprocessor can be attached either to a belt or sling that fits to the bodies form. Our prototype will be developed using the Arduino microcontroller and Raspberry Pi microprocessor. The Arduino will be the main hub for all the major sensors as it already includes an analog-to-digital converter. Sensors that are not compatible with the Arduino or require too much memory space will be connected to the Raspberry Pi. This includes additional sensors and the GPS device. Wireless communication between the M-GU4RD and an overseeing device will be done via a transmitter attached to the Raspberry Pi. In addition, a printable circuit board (PCB) will be used as our power control unit (PCU). This will be designed in order to properly distribute power to all sensors and devices.

The M-GU4RD will transmit all information to a secondary device that displays and translates all relevant information onto a display. The graphical user interface (GUI) shown on the touchscreen device will simplify all the sensor information so that an overseer can monitor all units in the stressful situations they may be in. This peripheral device will consist of a second Raspberry Pi with a receiver attached to it. This will be connected to a Raspberry Pi certified touchscreen display. From here an outsider can check the various vitals and GPS information and execute orders.

When deciding on the main components to the M-GU4RD, the first device to be selected is the microcontroller (MCU) and microprocessor (MPU). This is the case because everything revolves around these devices as they are the main control of the system and everything must be connected to them. In a sense, no exterior device or sensor can be decided on until a central control is established as they must be compatible with the MCU/MPU. The Raspberry Pi and Arduino were selected as they are both widely supported in hardware and software, inexpensive, and customizable. A problem prior to selecting these devices was whether a medical development board should be used instead. This idea was rejected as it did not allow for as much flexibility and uniqueness in design. While it is possible to construct this design with just a microcontroller, the microprocessor was added to enable more flexibility in regards to support and space. This gives the team more options and the ability to make additions to the original M-GU4RD design.

After arriving at a consensus on the brains of the M-GU4RD the team selected biometric sensors that were compatible with either the Raspberry Pi or Arduino. There were many options but only a few met the standards the team wanted in the device. These standards being accuracy, durability, and additional features. In the case of finding a capable ECG sensor it was found that some chips did not measure both heart rate and respiratory rate. So, our search was narrowed to a device that could. This came into account in selecting the ADS1292R ECG/Respiration Shield for Arduino as our ECG device and sensor. To get the last vital necessary for the M-GU4RD, body temperature, the team only had a few reliable options. So, the team selected the DS18B20 as it was cheap, durable, and simplistic in design.

As for location tracking, the NEO-6M GPS unit was selected. The primary reason the team selected this device is because it is compatible with both Arduino and Raspberry Pi and it also includes an antenna. This provides some flexibility as the GPS can be mounted on both devices and its antenna can be used or not depending on the receiver and transmitter combination the team decides to use. In addition the NEO-6M GPS unit is just as accurate as the other more expensive choices so quality is not sacrificed in constructing the M-GU4RD. There is also a unique function that this GPS provides in that it contains a third axis that can be used to monitor height which eliminates the need for an altimeter. This can then be used in order to detect floor location when a first-responder is located inside a building.

The idea of making a separate touchscreen device controlled by a Raspberry Pi at the receiving end of the M-GU4RD transmission was to create a designated system control housing the graphical user interface (GUI). This idea was constructed further into the design process as originally the team was going to transmit information via Wi-Fi to an application software holding the GUI. Instead the team decided to create a peripheral device dedicated to monitoring M-GU4RD users.

## **6.2 Printable Circuit Board (PCB)**

The M-GU4RD device will need to have a printed circuit board designed for it. The purpose of the PCB is to distribute power from the supply, which will more than likely be a lithium ion rechargeable battery, to the load. The loads in the case of this project will be the Arduino, the Raspberry Pi, and all of the sensors to collect data. The power supply will need to be able to power all the components and last at least 6 hours to meet the project requirements. The job of the PCB will be to direct the power from the source to all the components of the device.

The circuit that will be designed to achieve this goal will utilize dc to dc converters to step down the voltage of the power source to the varying operating voltages of the sensors and microcontroller. Some devices use the same voltage so those components can share the appropriate output from one of the converters.

It is very important that the output voltages to power all of the devices are regulated. The importance of a regulated voltage is that some devices will vary the amount of current



drawn depending on its activity. If the device is performing a lot of tasks or the temperature is changed, the current drawn by the device can change. A regulated output voltage conveniently allows for a change in load current without dropping voltage. If the voltage were to drop too low, the device may not function properly or may turn off all together.

Another function that the PCB may have is to electrically connect everything together. Although the sensors can be directly connected to the pins of the Arduino, it may be beneficial to have the PCB connect all these devices together. Having the wires stick into the pins of the Arduino is not a reliable way to keep the device together. It will be fine to test by just plugging the wires into the pin, but for the final design a PCB that connects everything together will be a more permanent solution to tying the project together.

The PCB is a board that has conductive tracks within a plastic to implement a circuit. For testing and development purposes a breadboard will be used. The importance of using a breadboard is that during the design process many errors may arise that will need fixing. A breadboard allows for simple modification to temporary circuits, therefore if a problem arises the team can think of a solution and modify the circuit to resemble that solution. Once the designing based on the breadboard is finalized, the circuit design can be drawn up online on a PCB. However before testing out circuit designs on a breadboard it would be wise for the team to run simulations on computer software to get an initial idea of what kind of circuit will work.

### **6.2.1 Changes Made in Senior Design 2**

As the team further understood the requirements and limitations of the project the concept of the PCB design was altered significantly. Upon hearing that microcontroller development boards were not allowed in final products the team decided that the microcontroller chip needed to be implemented in the PCB. The final PCB includes the Atmega2560 at the center with traces to necessary pins to ports for the sensor data connection. A buck converter circuit is also located on the PCB to convert the 7.2V source voltage to the appropriate 5V operating voltage of the various sensors and devices. Many headers were put into the PCB design to easily connect the sensors to the PCB. The circuit design includes a section for the battery charging circuit. Some additional hardware features of the board include the ICSP connections to program the chip easily, and additional serial ports to communicate for troubleshooting purposes. The final PCB design for the M-GU4RD is displayed below.

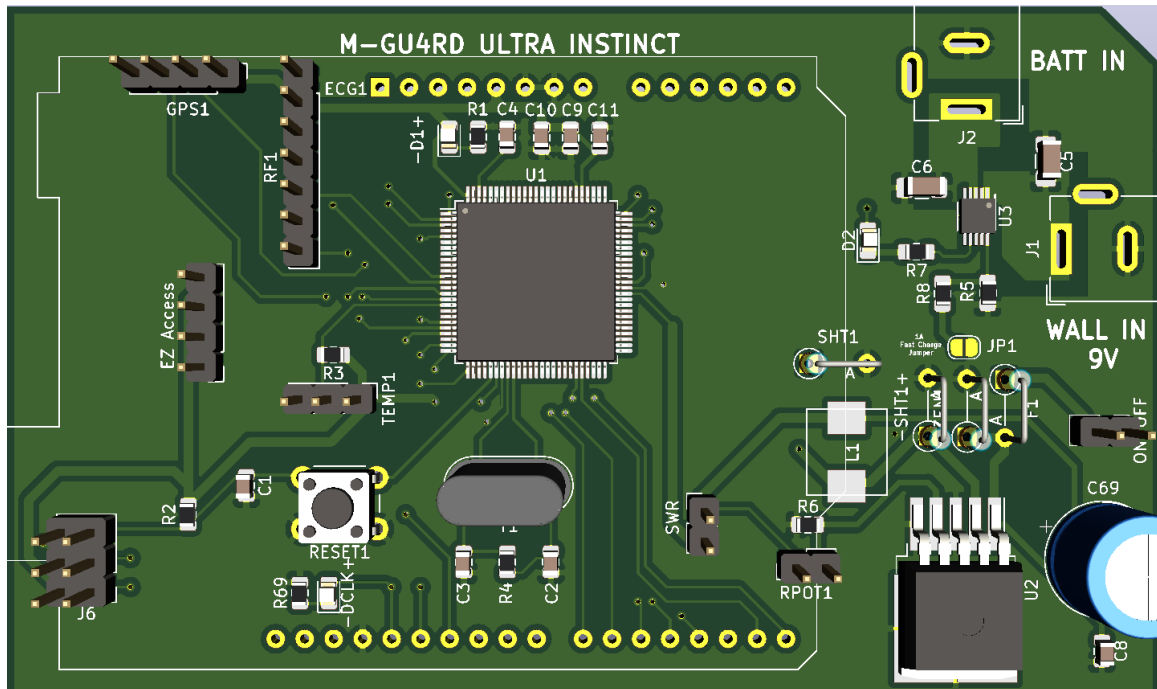
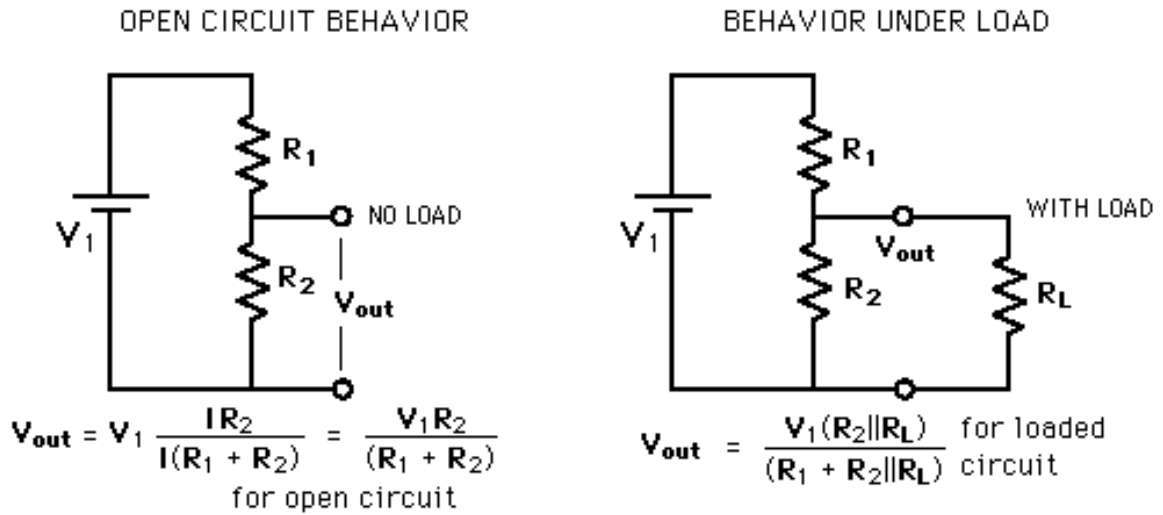

*Figure 53: Finalized PCB Design*

### 6.3 Relevant Circuit Design

The printed circuit board should have a circuit that functions as an efficient and convenient way to distribute the power from the battery to the sensors, microcontroller, and microprocessor. A major task for the PCB design is to change the voltage from the power source to the appropriate operating voltages of each device. There are many ways to achieve this feat, but some ways will be more advantageous for certain applications.

A very naive way to accomplish the goal of outputting the appropriate voltage is to create a voltage divider. The voltage divider circuit uses two resistors in series. The two resistor values are designed such that the second resistor holds the voltage that is desired for the load device. The load device is then attached in parallel with the second resistor. There are many issues with this design. For one thing, there is incredible inefficiency in that the resistors use up a considerable amount of power that becomes useless. Another issue for this circuit design is that the introduction of the load when connected to the circuit will change the output voltage, since the load itself can be modeled as a resistor. This parallel resistance decreases the overall resistance and increases the overall current. As a result the output voltage becomes less than what was designed for. In other words this voltage is not regulated so the load may not see the voltage necessary to run properly. Another limitation to this design is that the output voltage must be less than the input. A voltage divider can be designed taking into account the resistance of the load to get a closer output voltage, but loads do not always remain constant. Depending on the device the load resistance may change for various reasons which could alter the current that flows through the device. A capacitor can be placed in parallel to reduce voltage ripple at the output, but the inefficiency of the design would not be good at all for most applications. For the M-GU4RD, the voltage divider would not be a very good idea to give the right voltage to the output.



*Figure 54: Voltage Divider*

Another circuit idea to get the right voltage outputted for the different devices is to use an operational amplifier. There are many ways to implement an operational amplifier to produce the appropriate output voltage given an input voltage. An advantage to utilizing an operational amplifier is that the output could be greater than or less than the input voltage. Resistors of different values are used to manipulate the voltage gain of the circuit. The ideal operational amplifier had infinite voltage gain, infinite input impedance, and zero output impedance. The operational amplifier consists of a bunch of transistors to achieve those ideal requirements. Operational amplifiers are incredibly useful in circuit design, there is the concern however with the power consumed by the resistors. A way to reduce this wasted power would be to increase the resistance values, since the voltage gain for operational amplifier circuits usually depend only on the ratio of the resistances rather than their actual magnitudes. Operational amplifiers would be a plausible solution to the problem of getting the right voltages to the devices of the M-GU4RD, however there may be better options to consider.

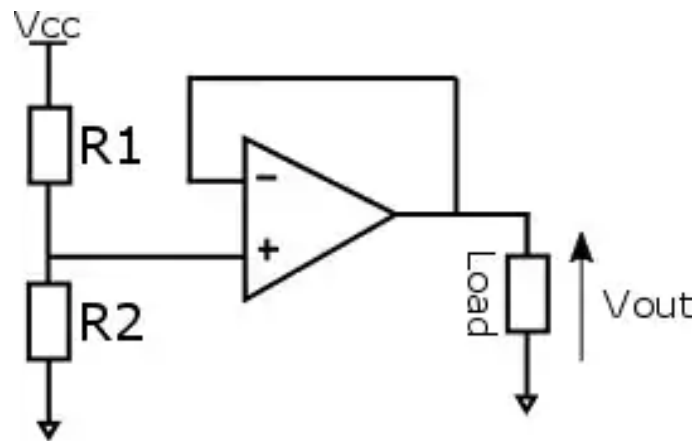

*Figure 55: Operational Amplifier*

There is a device that is designed specifically for this task known as a dc to dc converter, sometimes known as regulators. Dc to dc converters, or regulators, are split between two types: linear and switching. The switching counterparts are more efficient than the linear regulators. This device takes an input voltage and outputs a voltage depending on the duty cycle of the switch that is a part of the device. There are many topologies for switching dc to dc converters that simply rearrange where the switches are located and where the inductors are located. By doing this, the device can produce different voltage gain equations. The inductor's purpose is to hold the current, since inductor current cannot change instantaneously. This keeps the current relatively constant with some ripple depending on how large the inductance is. A capacitor is also placed in parallel to the output load reduce ripple and to regulate the voltage, since capacitor's voltage cannot change instantaneously.

Some basic topologies are second order dc to dc converters known as buck, boost, and buck/boost converters. The buck converter can output a voltage that is less than the input voltage, the boost can output a voltage that is greater than the input voltage, and the buck/boost can output a greater or lesser voltage than the input voltage. All of these voltage gains depend directly on the switching duty cycle assuming ideal conditions. There are also higher order dc to dc converters such as the Cuk converter and the SEPIC. These converters use twice as many inductors and capacitors as they are fourth order converters. Though the voltage gain is dependent on the duty cycle of the switching, the frequency of the switching is also of great importance. The frequency of the switching affects the current and voltage ripple of the output. These devices can be highly efficient in that they are designed for this particular task, but their efficiencies depend on other factors such as output current. There are some drawbacks to utilizing a dc to dc convert such as size. Because these devices use inductors, there are size limitations to this device. Inductors are typically large components, so the overall size is not as small as say an operational amplifier, which functions using transistors. Overall dc to dc converters would definitely perform the task needed for the M-GU4RD as the appropriate output voltage can be attained and it is regulated, but there may be concerns with the size of the device.

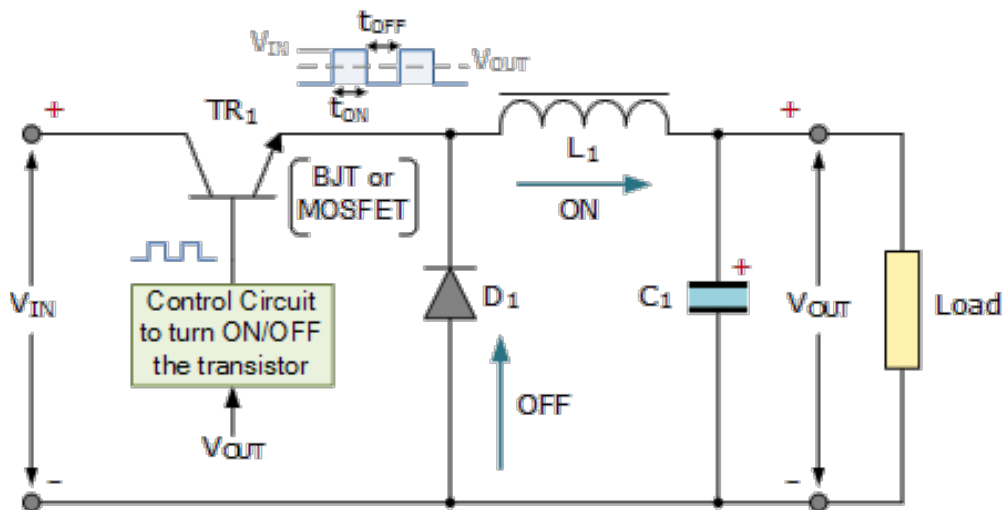
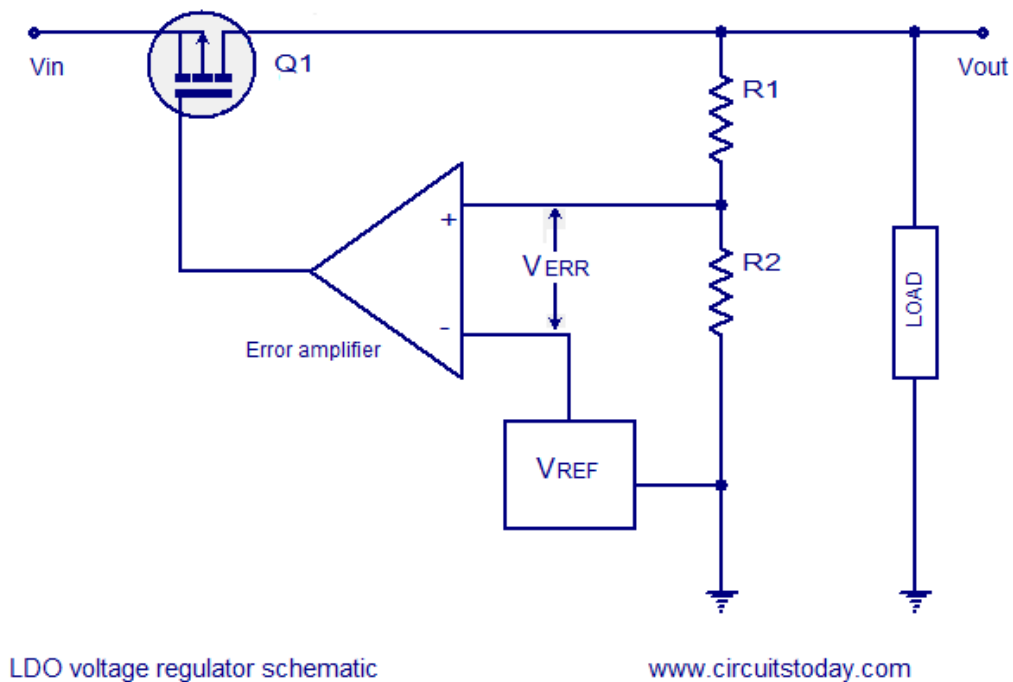

Figure 56: Switching

The linear voltage regulator achieves similar goals, but has many different aspects associated with it. The voltage regulator takes an input voltage and can output a specific voltage based on the actual device construction. Some voltage regulators even have an adjustable output voltage by adding an external resistor. Depending on that resistor value, the output voltage is altered, and the data sheet will have the equation for the relationship between those two values. The linear voltage regulator is limited in application as it can only output voltage lower than the input voltage. In fact, the input voltage has to be a certain value higher than the desired output to achieve said output. This extra voltage necessary to achieve the appropriate output voltage is known as the dropout voltage. Linear voltage regulators overall are much less efficient than switching regulators; however, when the load current is very small, the linear regulator is more efficient than the switching regulator. Linear regulators typically have a heat sink because they dissipate a lot of energy. The linear regulators are cheaper and simpler than switching regulators. The linear regulator utilizes a comparator or operational amplifier as a feedback component. The comparator has a reference value which is set to the desired output voltage. The other input of the comparator is attached to the output of the regulator and the comparator outputs accordingly to correct the output to bring it closer to the reference value.



*Figure 57: Linear*

## 6.4 Graphical User Interface (GUI)

One of the biggest features and advantages of this design is to create a simple, easy to read Graphical Unit Interface. The display must be clear and easy to understand in order to be utilized by people who might not have an intense training in this field. The goal is to make this design a very user-friendly design.

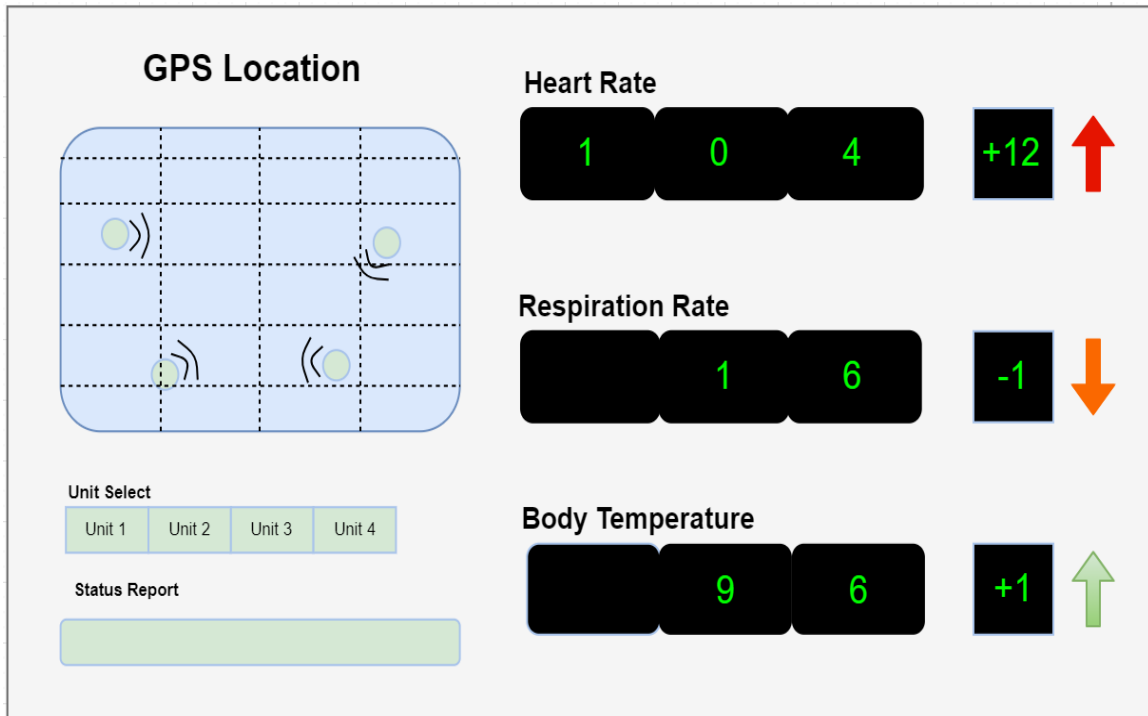

*Figure 58: Possible GUI display*

Our design is very technical and will incorporate a microcontroller with various sensors to interpret and send data to an outside device. Although a lot of this design will focus on the hardware, the graphical user interface is vital in accurately and effectively representing the information provided. The GUI will be dynamic and will constantly update and adapt to changes in location and health patterns in order to keep the user updated.

At the forefront of the GUI will be a dynamic map of the surrounding environment and the GPS locations of every squad member wearing an M-GU4RD. This display can be adjusted to show marked locations, a unit's range of view, and even a squad member calling for help. To the side of this display will be the vitals of the selected M-GU4RD user. These users can be cycled through to focus on one singular unit. The primary vitals displayed will be heart rate, respiratory rate, and body temperature. These vitals provide the most information as slight variation in these numbers can signal distress. Next to these numbers will be an arrow pointing in the upward or downward direction. Alongside these arrows will be a number that represents the deviation of that specific vital compared to their resting average. If their vitals go up an up arrow will display with a positive number. If their vitals go down a down arrow will display with a negative number. The purpose of these numbers and arrows is to simplify the results so the user of the GUI can understand everyone's status. In addition to these simplified measurements, sound and color alterations will signify issues in vitals. Green will signify a healthy status, yellow will serve as a warning, and red will trigger a noise meaning the user is distressed.

To accurately track the vitals of an M-GU4RD user there is important information to note. The heart rate, in beats per minute, should be within 60-100. The respiratory rate should be within 12-20 breaths per minute where hitting greater than 25 and lower than 12 is

considered abnormal. Body temperature in degrees Fahrenheit has an average of 98.6, but can be anywhere between 97.8 and 99.1. At 95 and below is when hypothermia is taking into account. All these averages will be displayed in green whereas slight variations will be displayed as yellow. In the case of severe changes in vitals red will be used.

	Green (Good)	Yellow (Warning)	Red (Danger)
Heart-Rate	Users resting number	Fluctuations between 60-100 bpm	Outside yellow range
Body Temperature	Users resting number	Fluctuations between 97.8-99.1 degrees	Outside yellow range
Respiratory Rate	Users resting number	Fluctuations between 12-20 bpm	Outside yellow range

*Table 9: GUI color indicators*

## 6.5 Fabrication

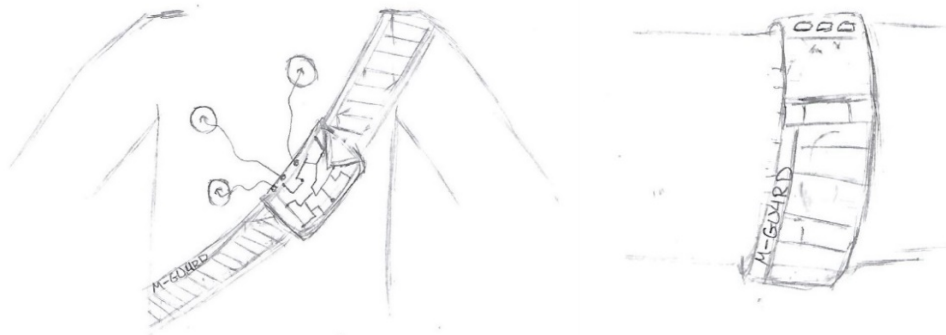

*Figure 59: Ideal designs*

When it comes to the actual design and look of the M-GU4RD there is a few things to consider: size and durability.

Depending on the various sensors, GPS system, microcontroller, and attachments the size will increase. This impacts where the M-GU4RD can be worn and how ergonomic it can be. Ideally the device should be small enough to be worn on the wrist, but if all the components are too large the team would like to keep the device within a reasonable size to be worn around the waist or carried over the shoulder. Another problem is sensor location. Certain vitals can only be found on designated parts of the body so this would have to be addressed as well.

Since the M-GU4RD will be used in the thick of duty it needs to be durable. This casing would have to be made of something strong and flexible to improve comfort. The main casing housing the microcontroller, GPS, and sensors would have to be made out of a strong metal alloy or hard plastic. It would have to be strong enough to endure certain temperatures and be water proof. This would allow the device to survive in conditions involving fires or heavy rain. The strap to attach this device can be made of a comfortable fabric that is not a nuisance to the skin and can be laced, tied, velcroed, or adjusted.

## **6.6 Future Development**

The core of the M-GU4RD's design is designated to recording vitals and monitoring a person under stressful situations. That is why the team put a heavy focus on the main vitals of heart rate, respiratory rate, and body temperature. In addition location was added as it would also be an important factor during rescue missions, gunfights, and various other dangers that may involve first-responders. Condensing down the design was purposefully done to focus on the bare essentials, but the intent was to expand further.

In terms of fabrication and the overall look and feel of the M-GU4RD, future development should be focused on reducing the amount of space the hardware occupies. This can be done by using smaller components and condensing features onto one platform. As more advances in technology are made this will come natural and maybe the M-GU4RD can one day be a simple wrist mounted device. In addition the ergonomics of the device can be adjusted using more flexible materials and non-invasive sensors. There are also plenty of more features that can be added to the design and it would be ideal if several M-GU4RDs could be made that could specialize in certain practices even having customization options and interchangeable parts.

To improve upon this original design several features can be added:

- Gas detection
- Altimeter
- Communication

This section will discuss future development for the M-GU4RD that could be considered. Not all products will reach full maturity in one year's time. Also, the first product typically is far from the best of its kind. Working on this project for a year, the group will learn new insights on different design ideas as well as extra features that would enhance the product. Some extra feature ideas have already been discussed by the team. As the project develops more, even more ideas will arise for the future development of the M-GU4RD.

### **Altitude Sensing:**

One feature that can be added to the design is altitude sensing. The two ways that the altitude data can be achieved feasibly for this project would be through the GPS and through a barometric altimeter. Many GPS modules can acquire information on altitude by utilizing satellites similar to how two dimensional position is acquired. A future addition to the device could utilize GPS to gather data on height. Another way to find altitude is



through a barometric altimeter that measures the pressure in the air and figures out the height based on that pressure in comparison to pressure at the sea level. This information would be beneficial in the case of first responders acting in buildings. The altitude data can determine which floor of the building the responder is on.

### **Gas Sensing:**

Another feature that could be implemented to help first responders would be gas sensing. There are many sensors that can detect the amount of specific gases in the environment. Gas sensing can be incredibly important as it can indicate whether or not the chemicals in the air are safe for the person. This would be especially important for a firefighter in a burning building. There are many cases where the firefighter passes out or dies due to the lack of oxygen in the building. It may be helpful to know how safe the air is for the fire fighters.

### **Mobile Application:**

As the design stands now, the RF transmitter will send the data of the first responder to a receiver RF module that can be connected via USB to any windows tablet or laptop. A windows application will be developed to display all of the collected data. A future development that may prove helpful is to develop a way for the data to be viewed on a mobile device. Though being able to view the data from any windows tablet or laptop is already quite flexible, the development of a mobile application in which the data can be sent may be beneficial considering how commonplace a smartphone in today's society. Also, it would be advantageous to expand the application to other operating systems that are not just windows os.

### **Camera:**

In the future it would be beneficial to install a live camera feed feature to the device. The camera module can be attached to the clothing of the first responder. The purpose of a camera would be to monitor what the first responder's environment. This will help to understand the situation that the person is in. The camera would simply act as a sensor retrieving image data and sending it through the raspberry pi to the person monitoring the first responder. Processing audio through a microphone would also improve the overall design. The monitor would not only be able to see what the first responder sees, but also hear what the responder hears, or if the responder wants to communicate with the monitor.

### **Linking Between Devices:**

A concern that the team discussed was the range on the RF modules. The first thought to fix this problem was to get a new RF module that has a larger range, but that would drastically increase the price of the product. Another way to solve the issue may be to allow communication between devices. For example if one responder is too far from the monitor to send the data, then it can send the data to another M-GU4RD that is closer to the monitor. To apply this function would require heavy software coding, but should definitely be

feasible. There are limitations to this solution as well. If all of the responders are out of range then no data can be sent to the monitor. Additionally, if there are only a few responders within range, the amount of data they have to pass may be too high to process or send. This may result in delayed transfer of data. This solution would require more effort than simply buying a higher quality RF module, but would be a cheaper solution, though it has its limitations.

## 7.0 Project Construction & Coding

This section includes design schematics, construction, and programming. Included here will be all the final decisions on the physical construction of the M-GU4RD and how it will look in addition to all the software developments and how they will be done to construct the GUI.

### 7.1 Battery Selection

To appropriately choose a battery for this project it is necessary to analyze the power consumption of all the loads in the device. This battery will need to power three sensors, a microcontroller, an antenna, and a microprocessor. The table below shows the operating voltage of all the devices and approximate current drawn for each device. The desired battery will need to have a high enough voltage to supply each device and enough capacity to power the devices for an extended period of time. Therefore when purchasing batteries, two major specifications of importance are the voltage and the charge which is typically measured in mAh. To get an approximation for how long the battery will last we can divide the total mAh charge of the battery can be divided by the total current drawn by all the devices. The resulting number will be the duration of the battery in hours. The table below shows the expected currents drawn from each device in this project as well as the operating voltage range.

Component	Max Input Voltage	Max Input Current
Arduino UNO	5V	36
Raspberry Pi A+	5V	2500
EKG	3.3-5V	100
GPS	3.6V	39
RF Modulator	3.5-5.5V	42
Temperature Sensor	3-5.5V	1.5
Total Current Drawn		2718.5

*Table 10: Power Supply*

Most of the devices run off of 5V. The arduino has a built in 5V regulator and a built in 3.3V regulator. The arduino can be powered via USB, but it is recommended to power the microcontroller with an external supply between 7V to 12V. The reason for doing this is that the regulators for the external DC source can supply a higher max current than power drawn from the USB. The regulators can supply up to 1A from the 5V regulator and 200mA from the 3.3V. These max ratings are more than enough to power all of the sensors and the antenna. The Raspberry Pi also runs on 5V but draws 2A which the microcontroller would not be able to supply. The group decided to utilize a design in which a 7-12V rechargeable battery will power both the Raspberry Pi and the Arduino. The arduino will power all of

the sensors and the antenna. Further detail on the circuit design will be described in another section.

### **1268 12V 6800mAh Lithium Ion Polymer Rechargeable Battery:**

This rechargeable battery outputs 12V and has a charge of 6800mAh. This battery comes with a charger and costs about \$20. There are built in protection circuits for overcharging, over-discharging, short circuits, and overvoltage. The whole package weighs 9.24 ounces and measures 4.49in x 2.24in x 0.83in. This battery would work for the project application of the M-GU4RD in terms of power output, size, and weight. The battery also comes with connectors that can be directly connected to the Arduino. The battery also comes with a charger and charger connector. Based on the expected total current drawn for this device, the 6800mAh battery should last about 2.5 hours. Using a 12V source is beneficial because the 12V can be directly connected to the Arduino to power the sensors, and only one external regulator will be necessary to power the Raspberry Pi. This battery would be perfect for the project.

### **3.7V 10000mAh Lithium Ion Polymer Rechargeable Battery:**

This rechargeable battery has a huge amount of charge. For the purpose of the M-GU4RD, this battery would allow the device to last about 3.7 hours. This duration is a considerable amount of time and well beyond the engineering requirement specifications. The device measures 8.8mm x 70mm x 129mm which is not much volume at all for the project. Though the dimensions and charge are very good, the voltage will result in some complexity with the design. The Arduino needs 7-12V to be powered, while the Raspberry Pi needs 5V. This means that if this battery were used, two external boost converters would be needed for the overall system. Another drawback to this battery is that it does not come with a charger, so that would need to be designed or bought separately. The price for this battery is about \$15. Although this battery may meet the specifications for the application, it brings about some complexities to the design.

### **12V 8000mAh Lithium Ion Polymer Rechargeable Battery:**

This battery is very similar to the first battery presented in this section, but it has 1200mAh of extra charge. This battery is not just larger in terms of charge, but also in regards to physical size. The dimensions of this device are 127mm x 65mm x 23mm. This device has the same advantages as the first battery and can make the device last about 2.9 hours. The drawbacks to this device; however, is that the device is physically larger and weighs more. Though this battery would definitely perform the task needed in this project, the size and weight are undesirable for the project. This battery can be purchased for around \$17.

The battery chosen for this project is the 12V 6800mAh Lithium Polymer. The reason we chose this battery is because it is relatively cheap, it conveniently outputs a good voltage, and it has a large enough charge to provide a good enough duration for this application. The group also chose this device because its size is not too large and it is not too heavy either to be wearable. This device is also convenient to use because it comes with a charger

and a connector. The output wire can also be used to directly connect to the input power of the Arduino. Because the device simply will need only one external buck converter for the circuit for power distribution, it makes it a simpler design.

The 1268 manufacturer from DX.com is the manufacturer we chose for many reasons. For one reason, it is the cheapest option of all the manufacturers for the battery of this size. The second best manufacturer for this device would be Fheaven which could be ordered from Amazon.com. Fheaven had a 5 out of 5 rating, but there was only one review, whereas the manufacturer from DX.com had 21 reviews and had a 4.1 out of 5 rating. Even though it was a lower rating, there were more samples to base the decision off of. Overall the device from DX.com had great reviews and was cheaper.

Battery	1268 LiPo	3.7V LiPo	8000mAh LiPo
Size	Length :114mm Width: 57mm Height: 21mm	Length: 129mm Width: 70mm Height 8.8mm	Length: 127mm Width: 65mm Height: 23mm
Voltage	12V	3.7V	12V
Charge	6800mAh	10000mAh	8000mAh
Cost	\$20	\$15	\$17

*Table 11: Battery Selection*

### 7.1.1 Changes Made in Senior Design 2

The power requirements significantly changed upon learning that a Raspberry Pi cannot be used for the M-GU4RD. The amount of power needed dropped tremendously, so the need a large battery source vanished. This allowed the choice of using smaller portable batteries which was perfect for the design. The battery chosen as the final power source was two 3.6V lithium ion 18650 packaged batteries connected in series. These batteries both have a charge of 2600mAh which is more than enough to meet the battery life requirement of the project.

## 7.2 Receiver & Transmitter Design

This body diagram demonstrates from a high-level perspective how this transmitter will be power up. The transmitter will have two microcontroller which are the Arduino UNO and the Raspberry Pi 3 A+. The Source of power will come from the Battery and this will power up the Arduino UNO which has a built-in voltage regulator, this microcontroller will provide the power to the rest of the components of the transmitter such as Temperature sensor, Electrocardiogram (ECG) sensor, GPS and RF Module. The 12Volts battery will also provide in parallel the sufficient power to the Raspberry Pi. Since the Raspberry Pi does not have a built-in voltage regulator an external voltage regulator and a circuit build for safety will be added in between the Power Source and the Raspberry Pi. The data will distribute between the two microcontrollers, The Uno will take the readings from the temperature sensor and ECG and the Raspberry Pi will take the data from the GPS and RF Module. Being the Raspberry Pi the one that process all the information to be send wireless.

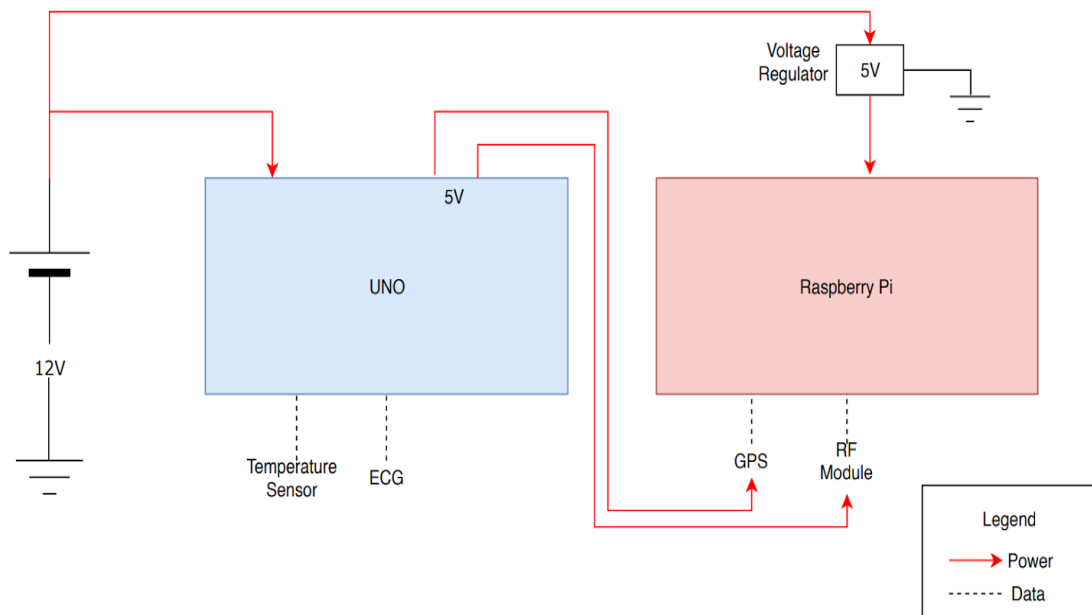

**Figure 60:** Tx High Level Diagram

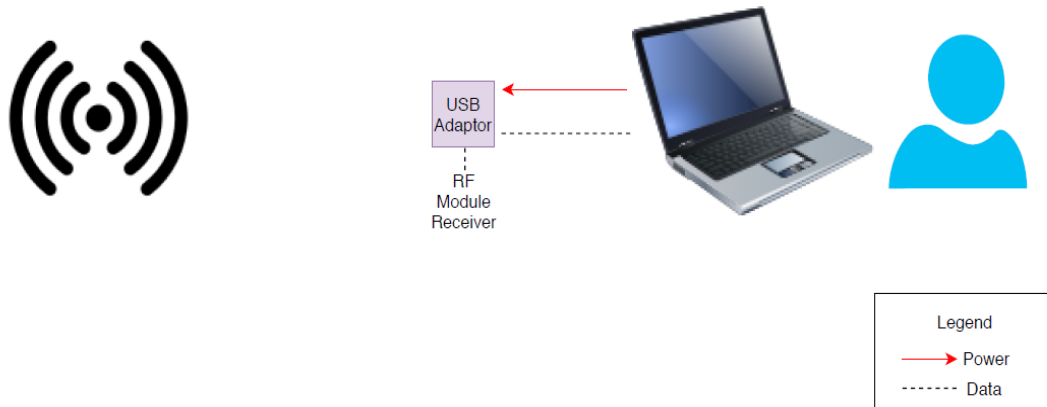

**Figure 61: Option 1**

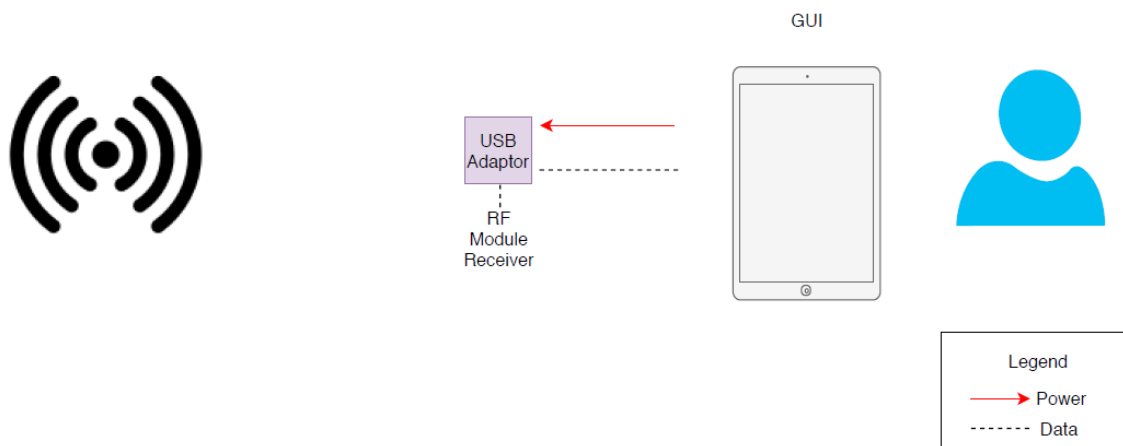

**Figure 62: Option 2**

When it comes to the receiver, the APC 220 comes with an USB converter that allows it to be connected directly via USB to either a laptop or a tablet. Either option 1 or option 2 work similarly from a power perspective, since these both will be powering up the RF Module via USB. The data will be received by the RF Module and then be send to the laptop or Tablet. These will have an application that will translate the data into information that can be read and understand by the end user. Alternately, the Raspberry Pi comes with a Wi-Fi Module that can be utilized to send the data to the GUI or Laptop.

### 7.3 Circuit Design

The group based the design of the circuit by first analyzing the power distribution needed for the components. All of the sensors and periphery devices run on 3-5V and draw very

little current. Most of the devices draw less than 50mA. The Arduino Uno with its regulated 5V can source up to 1A and its regulated 3.3V can source up to 200mA. The sensors therefore can be powered via the Arduino. The Arduino itself requires 7-12V input and draws around 40mA, depending on how many tasks it has to perform. The Raspberry Pi uses 5V and needs 2.5A. The team decided to use a 12V battery power supply to power the Arduino, which will in turn power all of the sensors. The battery will also power the microprocessor, but in order to do this a voltage regulator is necessary to step down the 12V to 5V. The Raspberry Pi cannot be powered by the Arduino because the Arduino cannot supply 2.5A. The Raspberry Pi receives power through a micro USB port. There are alternative ways to power the microprocessor like using two GPIO pins; however, this method is not safe because there are no protective measures in the Raspberry Pi for voltage spikes or current spikes. If this method was chosen, protective measures could be added to the PCB like zener diodes for voltage clamping and an inductor to prevent current spikes. The group found a very convenient and useful switching step down DC converter that can convert the 12V power supply to a 5V USB port efficiently. The general power distribution design has been described and can be visualized with the block diagram shown below.

Each sensor will have its own circuit necessary to operate as intended. Capacitors will be placed in parallel to the loads to filter out noise in the DC power signal coming from the Arduino. After researching how each component should be set up, the following schematic shows the Atmega328P microcontroller used in the Arduino Uno and how it is connected to power as well as all the periphery devices.

## **7.4 PCB Schematics & Design**

Designing the PCB is much more than just designing the circuit that it is meant to implement. Important considerations for PCB design also include the physical shape and layout of the circuit elements, the type of mounting, and the manufacturer. Other major topic concerning the PCB is the soldering of the components to the board.

Most, if not all, projects will require a packaged case of some sort that will hold all of the components together. For example, the M-GU4RD final product will have most of the sensors and electronic components enclosed within a rectangular plastic housing. Though the bulk of electronics has to do with the circuit design and how to make the product function, the physical design is equally important to the end product. Ideally the group would like the casing of the M-GU4RD to be as small as possible and as ergonomic for the user as possible, since it must be worn. What this means for the PCB is that the board needs to be small and a shape that is designed to minimize the size and complexity of the whole packaging. To reduce the overall size of the board the circuit elements can be designed to fit as tightly as possible without any overlapping of traces on the board. The circuit elements in general can be placed however we desire, so it would be wise to layout all the elements to make the desired shape for the board. The design for the M-GU4RD PCB will most likely be a long thin rectangular board to fit alongside the Arduino and the Raspberry Pi inside the case.



Another crucial factor in terms of physical design is the dimensions of the circuit elements and where they lie in the casing. Though the board itself will be very thin, the third dimension of space should not be neglected when designing the board. The circuit elements have a size associated with them. Typically resistors and capacitors are not too large, but they can be depending on what is needed for the circuit. Connectors need to be considered not only because they take up more space than circuit elements, but also because they need to have more empty space allotted for them to connect whatever needs to be attached to them. For the M-GU4RD, many connector will be needed to attach the pins of sensors to the board as well as connecting the board to the microcontroller and microprocessor. At the least, soldering pads or through hole mounts will be used to connect different wires which will also require some room for cable management and prevent possible damage to the wires or connections.

The type of PCB mounting is also an important aspect of the PCB design. There are two types of mounting to consider: through-hole mounting and surface mounting. Through-hole mounting consists of drilled holes in the PCB that have a ring of metal contact for soldering. Through-hole mounting is used with circuit elements that have legs. The leg is placed through the hole and soldered to the pad on the underside and/or the top side of the board for connection. The remaining portion of the leg can be cut off. Typically, devices that are used for through-hole mounting are larger than the equivalent devices used in surface mounting. Through-hole boards can sometimes be more expensive due to the extra process of drilling. Surface mounting generally produces a smaller board which is desirable. Soldering surface mount elements; however, is more difficult than soldering through-hole devices. The devices are smaller, so special tools would be necessary to hold the devices in place for soldering. A high quality soldering iron would be needed to reduce the risk of damaging the board. For this reason, many people send their boards out to get their elements soldered for a fee. Ideally the group would like to solder the components rather than spend more money to have someone do it. A surface mount PCB would be the desired choice for the M-GU4RD even with the added difficulty of soldering.

Choosing a manufacturer for the PCB is also critical. Different manufacturers will charge different amounts for the same circuit design. It would be wise to get quotes from several manufacturers to figure out which has the lowest cost. Research is also necessary to determine reputable PCB manufacturers and quality.

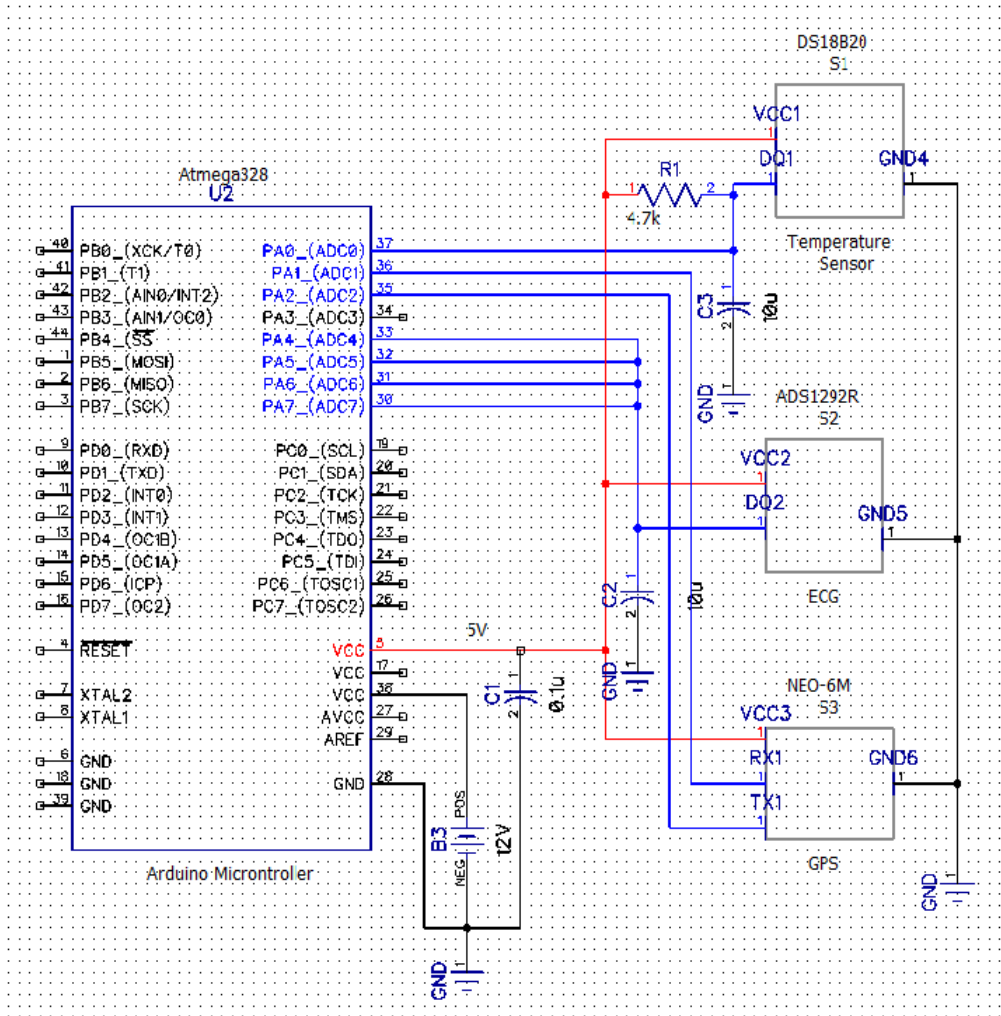

**Figure 63: Arduino Circuit**

The above circuit shows the basic circuit connections for the temperature sensor, ECG, and GPS with the Arduino and power supply. The 12V rechargeable battery powers the microcontroller which produces a 5V regulated output voltage. This 5V will power the three sensors. The ECG utilizes four pins for data as shown in the schematic. Another two pins are used by the GPS for transmitting and receiving data. One more pin is used by the temperature sensor for data. Capacitors are placed between the power and the ground and between data lines of the ECG and the temperature sensor. The reason for these capacitors is to eliminate or attenuate high frequency noise.

Component	Value	Supplier
B1	12V 6800mAh	DX
R1	4.7kOhm	From lab

C1	0.1uF	From lab
C2	10uF	From lab
C3	10uF	From lab

*Table 12: Arduino Schematic Components*

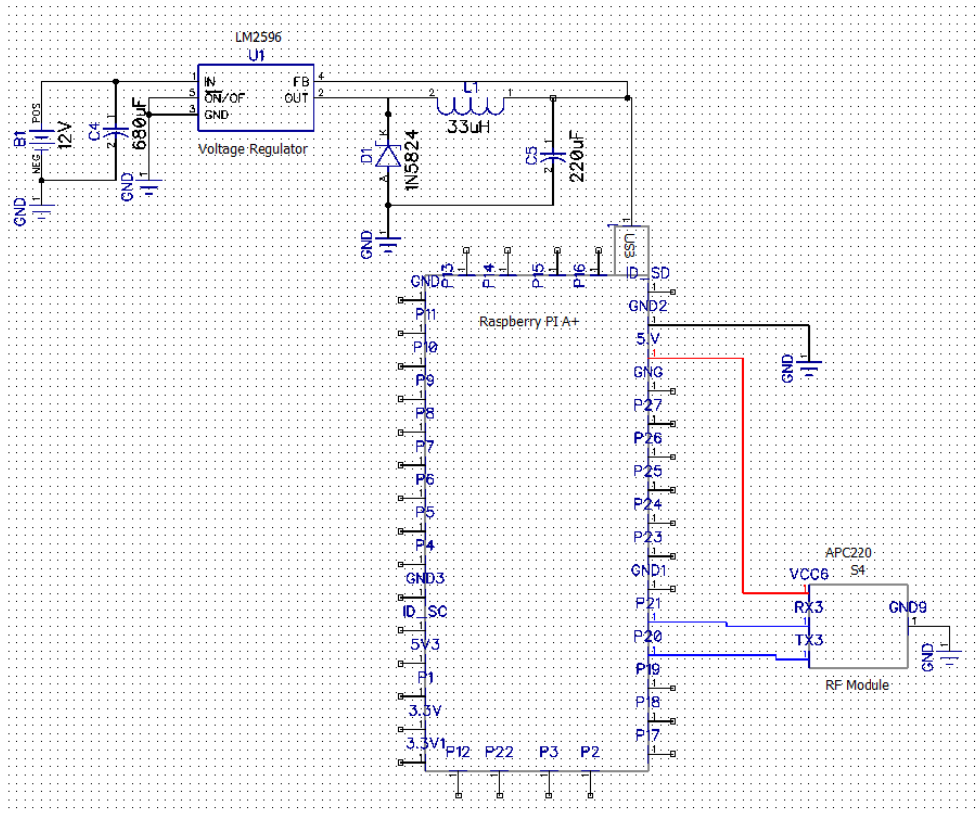

*Figure 64: Raspberry Pi Circuit*

The schematic shown above lays out how the RF module will be connected to the Raspberry Pi as well as how the Raspberry Pi will be powered. The same lithium battery used to power the Arduino will be fed to a 12V to 5V converter. This converter not only drops the voltage efficiently through switching, but also functions as a two wire to USB adaptor. This adaptor will allow a simple USB cable to power the Raspberry Pi directly. The RF module transmitter end will be powered through the Raspberry Pi with 5V. The transmitter also has two communication wires for transmitting and receiving with the microprocessor.

The table below shows the components, values, and the supplier for the electronic components in this circuit.

Component	Value	Supplier
B1	12V 6800mAh	DX
C4	680uF	From lab
C5	220uF	From lab
D1	1N5824	Ebay
L1	33uH	From lab

*Table 13: Raspberry Pi Schematic Components*

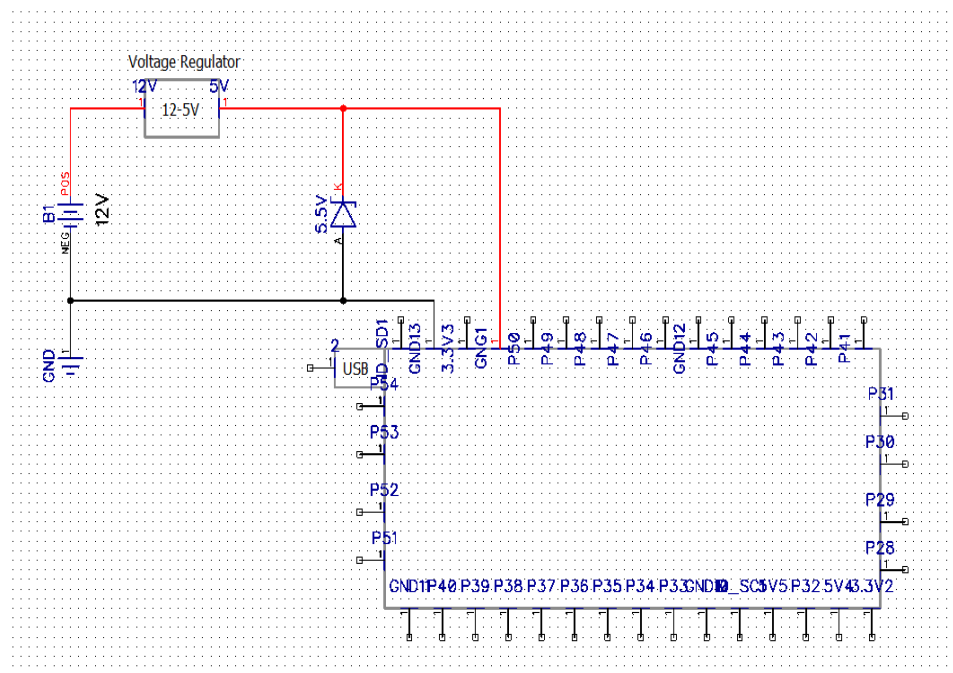

*Figure 65: Safety Circuit*

The circuit above is a design for the option of utilizing the GPIO pins of the Arduino to power the whole board. Because the pins are not protected with circuitry like the main micro USB port, an external circuit element was added to provide protection from voltage spikes. A zener diode was placed right outside the pin with a breakdown voltage of 5.5V. If the voltage coming out of the regulator were to spike, which is likelier to happen at the instant its powered on, it would turn on the zener diode at 5.5V and basically prevent the voltage from shooting up higher and damaging the microprocessor. This design would be utilized if there were no convenient or practical way to power the Pi using the micro USB.

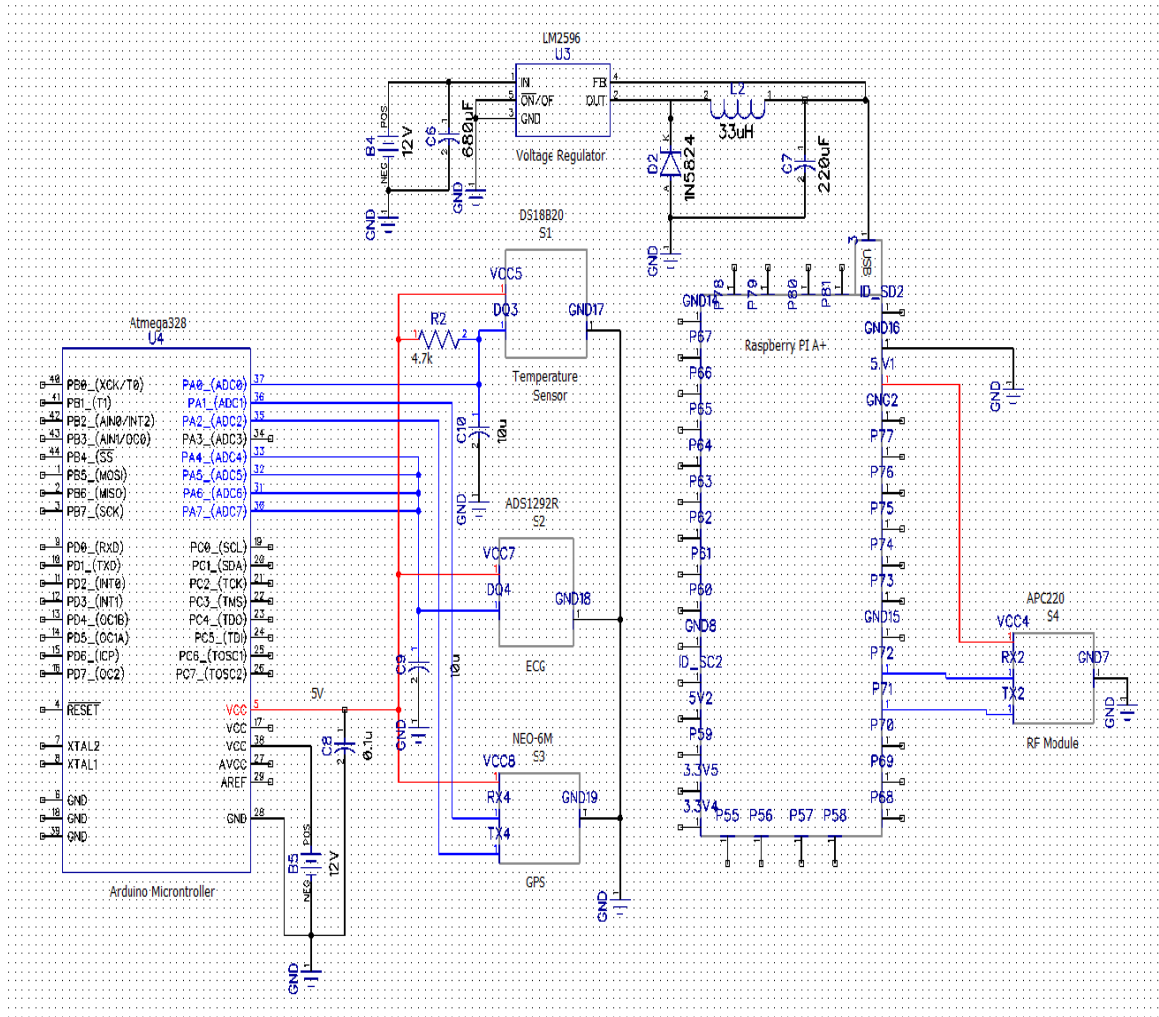

**Figure 66:** Overall Schematic

The above image shows the whole circuitry for the M-GU4RD design. The whole circuit contains a lithium ion battery that powers the Arduino microcontroller and the Raspberry Pi. The Arduino will then power the GPS, ECG, and temperature sensor. The microprocessor will power the RF module. The sensor data is collected by the Arduino and sent to the Raspberry pi to process and send the data to the receiver RF module.

### 7.4.1 Changes Made in Senior Design 2

Since alterations were made in the microcontroller unit that was used, new overall schematics were made by the group to be centered around the Atmega2560. The following images will show the schematics for the sensor connections to the microcontroller as well as the different circuit schematics for the power.

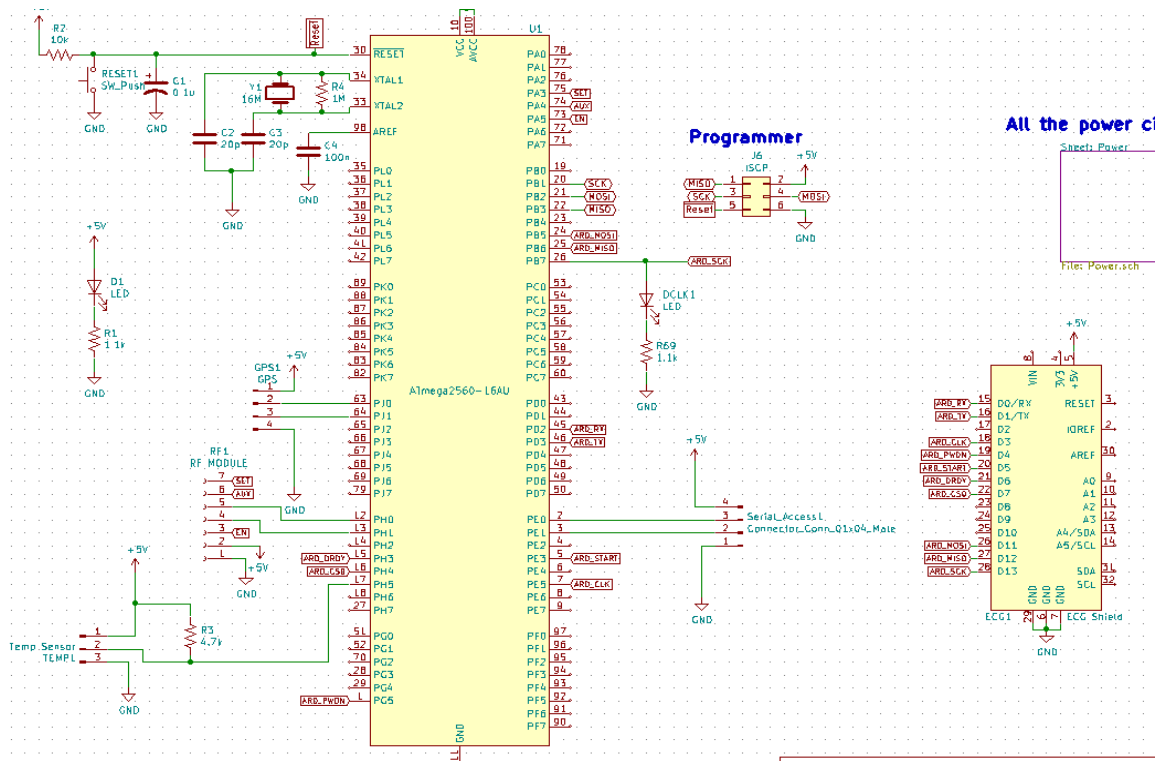

Figure 67: Finalized Overall Schematic

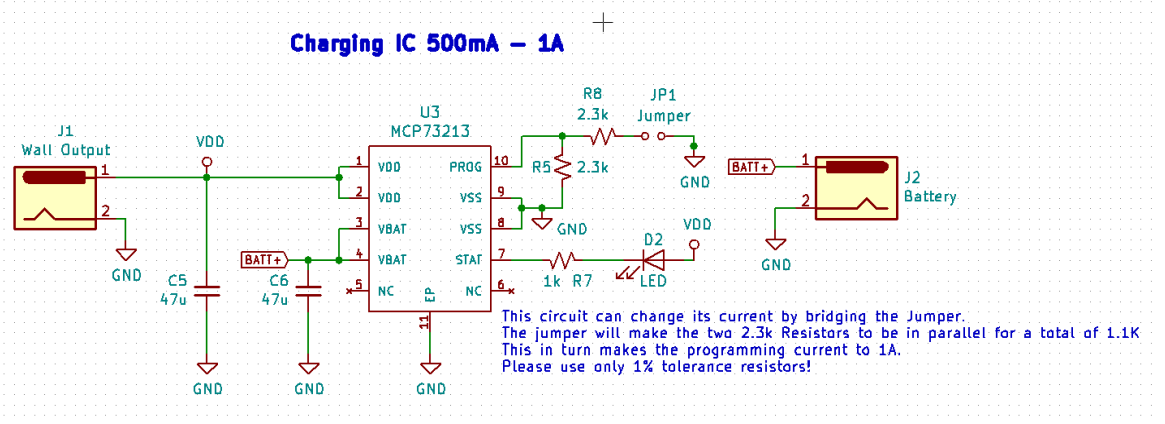

Figure 68: Charging Circuit Schematic

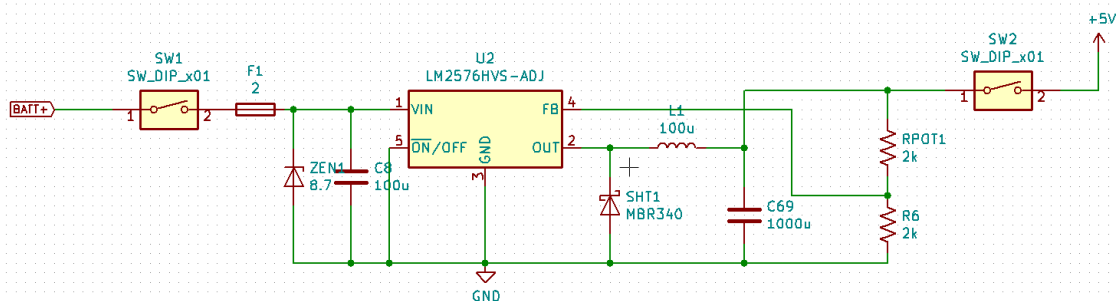
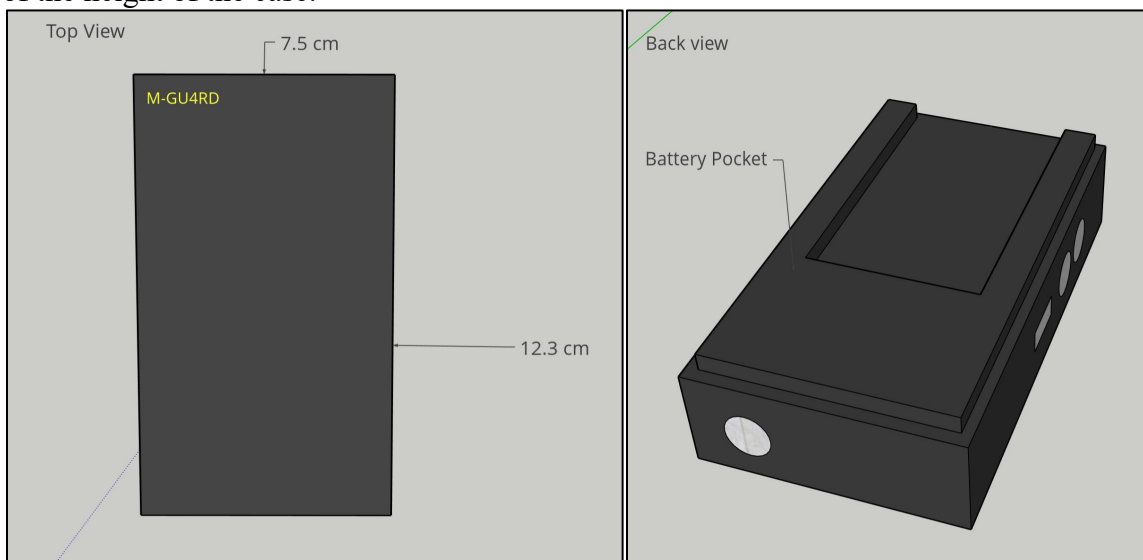

Figure 69: Buck Converter Circuit Schematic

## 7.5 Casing Fabrication

One of the design specifications for the M-GU4RD was the size. It was specified to be smaller than 20cmx20cmx15cm. Once all the major components arrived, the goal was to assemble them in a manner that the size of the case would be as small as possible. There were multiple ways the team approach this goal. The first approach was to simply stack the two microcontrollers, the PCB and the components on top of each other. This idea was discarded almost immediately due to how bulky this will make the case. The goal was to make this as portable as possible to make this an easy to use portable device. The other consideration taken was the size of the battery since from the research done by the team to obtain a battery that last enough as well as that can power up the components the multiple batteries in the market are big in size compared to the desired case. The following table shows the multiple dimensions for the big major components. This will be utilized to have a better idea of how to design this case from the length and width perspective. The height of this case will be taken by measuring the components mounted on top of the shields placed on the microcontrollers.

The way the two microcontrollers will be placed is by placing horizontally the Arduino (5.3 cm) and vertically the Raspberry Pi (6.5 cm) this will add up to a total of 11.8 cm. This measurement will represent the length of this case, to give make this case as tight as possible a minimum space will be given to keep the electronics tight. The length designated for the case is 12.3 cm. The width of the case was designed by using the length of the Arduino (6.9 cm) and since the Raspberry Pi is smaller this was not taken in consideration. Although, the PCB will be next to the Raspberry Pi to make up the different of sizes between the two microcontrollers. Lastly, to design the height of this case the shield of ECG was placed on top of the Arduino (since this provides the highest ensemble of electronics). By taking this measurement it was possible to provide a good approximation of the height of the case.



**Figure 70: Casing Dimensions**

As mentioned before, one of the main concerns when designing this case was to designate a location for the battery. This requires attention not only because of how would increment the size of the case but, also the heat that batteries can transmit to the rest of electronics. There two options to solve this problem. The first one being having the battery completely separated from the case in another compartment, possibly having this compartment next to the M-GU4RD case. The main issue with this was the cabling and possibly the need to create an external case for this battery. The second solution for this problem was to create a “pocket” in the back of the case. This pocket will allow the user to slide the battery into the pocket and facilitate a much closer connection compare to the first option. Another advantage of having a de-attachable battery is that the user will have the option to recharge this battery or replace it independently of having the case or not.

Component	Length (cm)	Width (cm)
Arduino UNO	6.9	5.3
Raspberry Pi A+	6.5	4.9
Battery	11.43	5.71

**Table 14:** Hardware Dimensions for main Components

The image below shows the side view of the M-GU4RD. Since the battery will be outside of the case the side of this will have apertures, these apertures will be used as ports to power up the Arduino and Raspberry Pi as well as to let the Temperature Sensor Probes and the ECG electrodes.

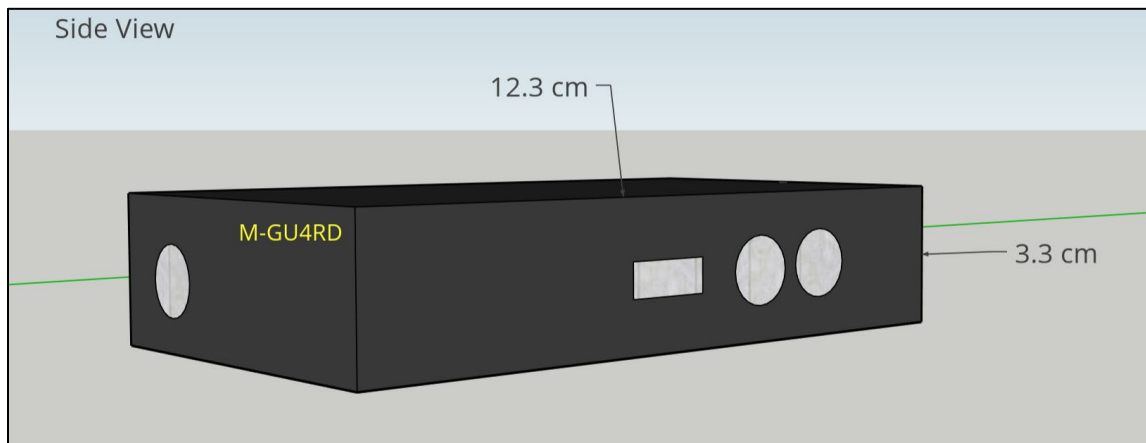

**Figure 71:** Casing side view

Lastly, it is important to mention that this case will be obtained via 3D printing. The material chosen for this is design is Acrylonitrile butadiene styrene (ABS). ABS is a petroleum-based plastic available for 3D printing. The reason for this will be the best material for this design is its high tolerance to elevated temperatures. The temperature to soften this type of plastic is approximate 105 °C (221 °F).



## 7.6 Software & Coding

The software development implementation for M-GU4RD will consist of C programming code that will enable the accurate reading from the following sensors to the Arduino UNO:

- DS18B20 Temperature Sensor
- NEO-6M GPS Sensor
- ADS1292R ECG & Respiration Sensor

The Arduino UNO will process this information and parse it to the Raspberry Pi, which will then interpret this data and send it through the APC220 Wireless RF transmitter to the receiver. Once the receiver obtains all this information it will then interpret it and translate it to an easy-to-read and user-friendly GUI version that will be displayed on the device of choice through the M-GU4RD application.

The Software functionality of M-GU4RD will be divided into three faces.

1. Data Input and Parsing
2. Encryption and Wireless Communication of Data
3. Decryption and Graphical Display of Data

### Data Input and Parsing:

The first phase of the software functionality “Data Input and Parsing” will be handle by the Arduino UNO, which is the main microcontroller that will enable the M-GU4RD device to read the necessary data inputs from the Temperature sensor, the GPS Sensor, and the ECG/Respiration sensor. This will be handle by careful parsing and interpretation of the unique data with their respective unique IDs and necessary headers and footers.

A sample data modeling diagram that represents how this part of the functionality will be adapted before parsing, encryption and transmission is presented below:

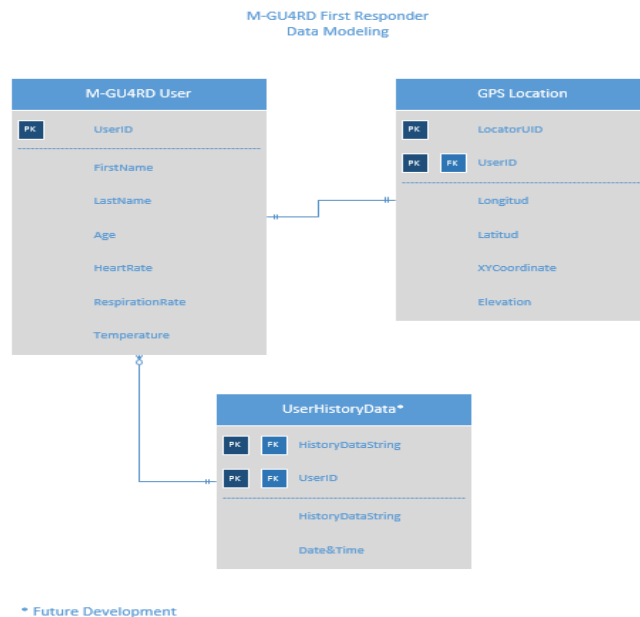

**Figure 72: Data Modeling**

## **Encryption and Wireless Communication of Data:**

The second phase of the software functionality will be handled by the Raspberry Pi. The parsed and interpreted data from the Arduino UNO will be sent to the Raspberry Pi A+, which then will be in charge of accommodating the data for transmission and encrypting it using a Python encryption algorithm for secured wireless communication purposes. The communication methodology will also include an error checking and data loss retransmission in case the wireless communication fails due to noise, obstruction, weather and/or unpredictable conditions.

## **Decryption and Graphical Display of Data:**

The third phase of the software functionality will be handled by the RF receiver module and the software M-GU4RD application. The RF receiver will collect all the chunks of data being transmitted by the transmitter and then send it to the application. The application will then proceed to decrypt the data in order to display it in a very user-friendly and easy-to-understand format through the GUI.

## **Windows Application**

Once the data has been transferred through the wireless communication antennas and received by the laptop/mobile device, all this data will have to be interpreted by the Windows application and shown in the GUI. The values will be analyzed and decrypted by the Python application in which case the data will be interpreted and accommodated to pass testing and threshold testing. There will be 5 main components that will need to be displayed in the application:

1. Heart rate statistics
  2. Respiration rate statistics
  3. Body temperature statistics
  4. GPS location
  5. Menu and Status section
1. The heart rate section will be determined based on the input readings and normalized for displaying purposes. The range for an average heart rate varies from 60 to 100 beats per minute, these averages and standards will be coded into libraries or structures in the code that will determine when a reading is close to or too far from the normal readings. This will determine the color coding representation of the severity of the stats being represented for each first responder.
  2. The respiration rate will also be determined based on a comparison between the input readings from the user and the average of the normal respiration rate which vary from 12 to 16 breaths per minute. However, there will be further testing for the sensors and based on how they operate the data will have to be translated to accommodate for an accurate reading comparison table, that will be hardcoded into the system as a library or data structure.

3. The body temperature rate will also need to be adjusted to the calibration of the temperature sensors. This will guarantee that the readings are acute when the sensors are put under different conditions such as jogging, running, or extra body heat due to equipment and gear usage.
4. The GPS location section will be determined between the raw coordinate data, such as latitude and longitude, and the Google Maps API. This will guarantee a very nice and easy-to-read display of the GPS location on the Google maps platform.
5. The last section will include the Menu and Status bars. The menu will be composed by aesthetic and standard buttons and icons for easy readability and usage. They will display additional options such as different user selection, additional user info, and status of current and last vitals data.

**M-GU4RD State Machine Diagram**

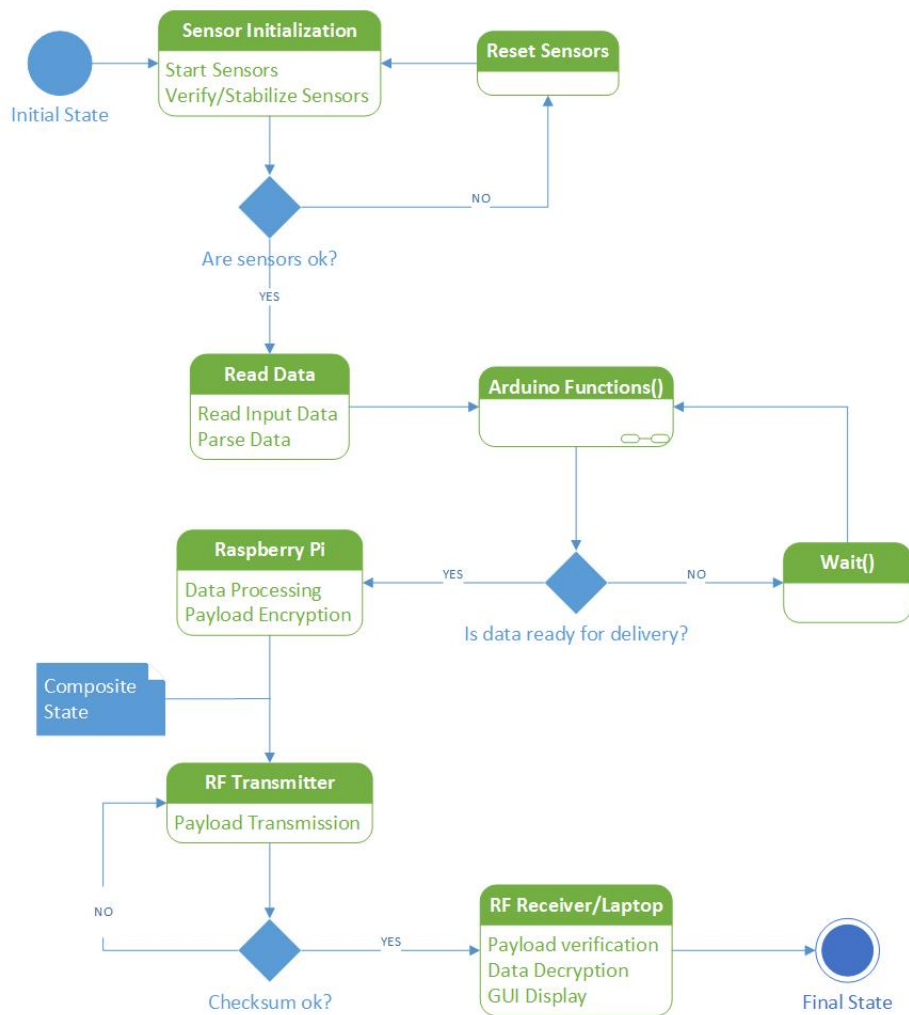

**Figure 73: State Machine Diagram**

## 8.0 Testing & Troubleshooting

Details on how each component will be tested will be described in this section. This section will also provide information on troubleshooting instructions for the various devices. For this project, each major component will be tested individually to ensure that each component works on its own. After finalizing the functionality of each component individually, we will start to test several components together at the same time using the designed circuits.

To create a successful design the team has to ensure these three criteria are met:

- That all vitals are picked up by their appropriate sensor and sent to the GUI
- The GPS is able to mark the wearer and send their location to the GUI
- The GUI reacts accordingly to wearer reactions and changes in vitals

To test that all vitals are read properly and sent to the GUI, each team member can wear the device and check that the correct vitals and their values are properly shown on screen. To improve the accuracy of the M-GU4RD our group can rely on modern medical equipment, devices such as running watches, and other applications that monitor heart-rate and various vitals. Vitals measured using other devices can be used as a baseline for how accurate our team needs the M-GU4RD to be.

To test that the GPS communicates with the GUI, each member can wear the device and we can test for distance. Ideally it would be best if the M-GU4RD can communicate with the GUI from almost any comprehensible distance, but it is more plausible to have the GUI user within a decent radius to monitor first-responders within a building. As long as the GPS works properly other additions to it can be made such as interpreting building layouts with multiple stories in the GUI and even showing a person's line of sight.

To test that the GUI responds properly to all stimulus it receives, each member would again have to wear the device and make sure the GUI reacts to changes in vitals. This would have to be done through physical activity. The wearer will have to run or perform some kind of exercise and the GUI would have to react by changing colors based on the wearer's performance. High intensity workouts such as running should at least turn the GUI yellow signaling changes in vitals.

The purpose for testing each part individually is because it assists in the troubleshooting process. If all components work on their own, but do not work when put all together, then it is likely there is an issue with the combination of all the components and not the component itself. Conversely, if all the components were initially set up together without knowing that each component works individually, it would be unknown whether the issue is a result of all the components attached together or if it is a faulty device. For the troubleshooting and testing process as a whole, it is simpler, convenient, and beneficial to start with one device at a time. By gradually combining the devices one by one, the root cause to any issues can be narrowed down as only a few variables will change with each test.

When the completely designed circuit functions properly on the breadboard, then the PCB can be ordered for manufacturing. Further testing will take place with the ordered PCB. Chances are that the first PCB will have issues associated with it due to the lack of experience and knowledge of the group in designing a PCB. Many issues can arise with the PCB that were not present with the working breadboard circuit. To troubleshoot issues with the PCB, voltage readings will be measured in areas of concern for the circuit and will be compared to what is expected from the breadboard circuit. A very common issue is shorts in the circuit, so a multimeter can be used to Ohm out the suspicious nodes. After analyzing all apparent issues, corrections will be made to the PCB design and a new one will be ordered. This process will continue until a working PCB is designed and can be used for the final project.

## **8.1 Arduino Uno**

As previously mentioned the Arduino UNO works with its own Arduino IDE software which facilitates the read, write and upload of written code or “sketches” to the Arduino board. For testing purposes the Arduino Uno was connected to the computer by itself to ensure all the correct LED lights were turned on and the board hardware was working. Secondly the Arduino IDE 1.8.7 for Win was installed and launched to start testing the communication link and code loader. To finalize a simple C coded script was written, verified and uploaded to the board to ensure its functionality.

After concluding the functionality of the IDE and the Arduino UNO board some extra libraries were added to ensure the testing of all the individual sensor modules will work as well.

## **8.2 Raspberry Pi**

The Raspberry Pi was tested with the default “Raspbian OS” recommended for the board. First we need to format the SD card that will be working as the main HDD for the Microcomputer. The SD Formatter 4.0 for Windows is the software of choice for performing the initial formatting of the SD card. After the SD card was formatted we proceeded to load the files from the tool “Noobs Lite”, this program allows us to install the latest “Raspbian OS” onto the board. Lastly, the Raspberry Pi board was plugged in and after installing all the necessary software we proceeded to test the GPIOs and the Hardware functionality of the board. The main component that will be attached to the Raspberry Pi will be the APC220 RF module. To facilitate the testing of both the board and the RF module the procedures and specifications of the testing will be included in the testing procedures part for the RF module section.

## **8.3 Temperature Sensor**

The temperature sensor has three wires: one for ground, one for positive voltage, and the last for data. The manufacturer for this sensor has used a black wire for ground, a red wire for positive voltage, and a yellow wire for data. Referring to an Arduino tutorial online, to properly connect this sensor to the Arduino Uno microcontroller, the red wire will be

plugged into the +5V pin, the black wire will be plugged into ground, and the yellow wire will be plugged into an input pin. For this sensor a 4.7kOhm resistor is necessary to read accurate measurements from the sensor. This 4.7kOhm resistor is placed between the +5V and the data wire. This is all of the circuitry required to test out the sensor. For convenience, the pins or wires of the temperature sensor will be placed on a breadboard. To complete the previously described circuit, the resistor will be placed directly on the breadboard and jumper wires will be used to connect the pins to the Arduino.

Once the hardware is set up, the final procedure for testing is the software. A simple code using the Arduino IDE will be used to initiate serial communication between the controller and the data input from the sensor. The program will be uploaded and run on the microcontroller. The serial communication display should appear and show the temperature readings from the sensor. The temperature reading can be displayed in degrees Celsius or degrees Fahrenheit based on the code used. For convenience, degrees Fahrenheit will be outputted, since our group is more familiar with that unit.

As the readings are displayed, the metal contact for the temperature sensor will be grasped in the hand of one of the group members to produce higher temperature readings. This procedure will serve as an initial test to ensure that the temperature affects the reading that the sensor acquires. A key trend the team should look for is an increase in the reading as the hand grasps the sensor. The temperature should also read somewhere near 96 degrees Fahrenheit. Fortunately the temperature sensor chosen is waterproof so to test for accuracy the sensor can be submerged in a glass of ice water and should read close to 32 degrees Fahrenheit. The reading can also be compared to another reliable thermometer. Based on some research a common issue with this sensor is that it will send a very low temperature reading when connected. The issue is a result of miswiring the sensor, so the circuit should be reanalyzed to ensure it is connected properly and that each contact is making a good connection. If issues occur in general, the group has the advantage of testing another ds18b20, since the product came as a pack of 5.

The temperature sensor was hooked up to the Arduino as described previously. The sensor was placed in the hand while the code ran. The serial monitor on the computer outputted the temperature in degrees Celsius as well as degrees Fahrenheit. As time passed, the temperature was increasing to the normal body temperature of a human. This tested the functionality of the device. To test the accuracy the sensor was placed in ice water. Below shows all of the data from the testing the temperature sensor. The temperature sensor demonstrated great accuracy and performance for this application.

## **8.4 Heart Rate Sensor & Respiratory Rate Sensor**

The ADS1292R ECG/Respiration Shield fits directly on top of the Arduino Uno utilizing a few of the ADC ports. The rest of the GPIO is still accessible from the shield which will be connected to the various other sensors. During testing, the ECG electrodes are attached to the body. The red electrode is connected to the right upper pectoral muscle, the blue electrode to the left upper pectoral muscle, and the black electrode near the right lower rib.

The ADS1292R ECG/Respiration Shield has its own provided code and GUI for testing purposes.

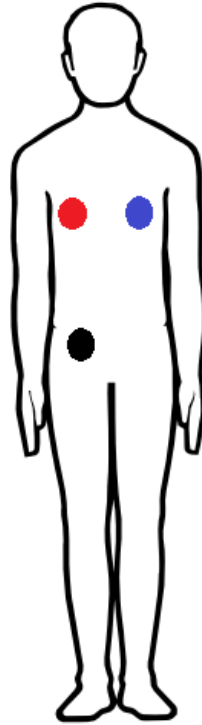

*Figure 74: Electrode Placement*

The team tested this device by powering the Arduino via USB to a laptop housing the code. By applying the electrodes onto one of the members and then executing the code that displayed the GUI. An electrocardiograph appeared displaying a waveform representing heart-rate and another waveform for respiratory rate. On the side is a value in beats per minute for the respiratory rate.

To determine that the ECG is reading correctly, the team member attached to the electrodes is measured at rest and then later after a bit of exercise. This is to test that the reading adjusts to a higher threshold after activity as both heart-rate and respiration increase with physical activity. The ECG accurately tracks heart rate, but the GUI doesn't display it in beats per minute (bpm). In addition the respiration is measured using a process called impedance pneumography, which is still a developing way of tracking respiration rate. This leads to discrepancies in the respiration values in beats per minute. These small problems will be addressed when developing our own GUI to improve accuracy. Other than that the ECG works properly.

## 8.5 GPS Module

The NEO-6M GPS module utilizes four pins: Ground, 5V, RX, and TX. The Ground and 5V pins are to power on the device, and the RX and TX pins are to receive and transmit data. In order to test this device, we simply need to connect the pins from the module to the corresponding pins on the Arduino. No extra electronic components are necessary to test the device, just jumper wires. The RX and TX pins on the module will be connected to the corresponding RX and TX pins on the Arduino which are pin 3 and pin 4 respectively. The 5V pin of the module can be directly tied to the 5V pin on the Arduino, and the ground pin will also be attached to the GND pin of the Arduino. The pins of the GPS module are through hole connections, so ideally a 4 pin connector would be soldered to the board so that a simple connection can be made.

After the wire connections are made, the appropriate coding needs to be uploaded to the microcontroller. The NEO-6M module will require the use of specific libraries to be used in the Arduino IDE. The GPS module gathers data from a multitude of satellites and outputs the longitudinal and latitudinal information of its location on the surface of Earth. The outputs of the module is sent to the microcontroller which is then sent to the computer that the controller is connected to via USB. The positional information should be displayed on the Arduino window.

To check to make sure that the GPS is working, the latitudinal and longitudinal coordinates that are measured can be compared to an accurate reference such as google maps using a smartphone or computer. There may be issues with collected accurate positional data if testing inside of a building, so if needed, the module can be tested outdoors as well to ensure that the module works. If the accuracy is considerably off, the group may look into using a different external antenna.

The testing procedure was performed for the GPS module. The data below shows the outcomes of the testing of this sensor. Overall the GPS proved to be extremely accurate even inside of a building.

## 8.6 Receiver & Transmitter Module

The APC220 RF Module comes with a receiver and a transmitter. For facilitating the testing and implementation a USB/TTL converter was included in the purchased of this module. To begin with the testing procedure, the following additional third party software is required for performing the testing on two laptop devices running Windows 7 and Windows 10:

- Silicon Labs Virtual COM Port (VCP) Universal Driver for Windows 10
- RF-TrulyMagical x86 for Windows

The testing will begin with the installation of the transmitter using the USB/TTL converter. The transmitter is plugged in to a laptop using Windows 10. After downloading and installing the proper Virtual COM Port (VCP) universal driver, the additional third party “RF-TrulyMagical 32bit version” software is installed in order to operate and set the



settings of the module such as RF Frequency, RF RX/TX rate and power. After all this is done the RF-TrulyMagical software should read the USB transmitter and we can initiate the connection.

On the second part of the set-up we connect the APC220 Receiver pins to the Raspberry Pi as shown in the figure below:

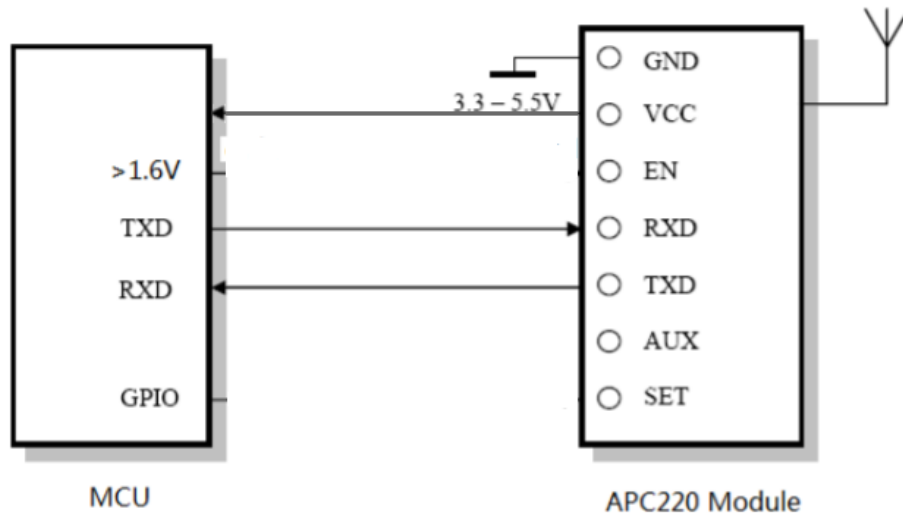

*Figure 75: RF Setup*

After the module was connected to the MCU, a small code snippet was loaded to verify the accurate readings from the transmitter. Finally, we proceeded to test the RF module by separating the laptops by different distance and establishing a connection between them. Once the connection was established two members of the group started to send messages to the receiver from the third party emulator.

On the other end, two members of the group awaited the messages with the receiver connected to the other laptop running Windows 7, and the verification code with the MCU terminal open for visual interpretation of the messages.

Ultimately, as seen in the previous figures the testing was successful at different distances reaching a maximum distance of approximately 800 ft. in a very dense residential area which could have interfered or altered the signal from the RF transmitter to the receiver.

## 8.7 Testing Conclusions

Fortunately, the testing showed that all the devices worked as expected and were implemented fairly simply individually. Quality wise, it is important to note that the ECG will need some calibration that can be enacted through coding. After the first trial of testing, more advanced testing details were discovered. For example, when connection for the GPS is more stable the group can test other features of the GPS besides location such as speed and bearing. Another interesting test with the GPS would be to compare the results when inside larger, more impenetrable buildings like a shopping mall. For the ECG it would be

interesting to test how the data compares when changing the location of the electrodes closer or farther away from the heart. Further testing for the temperature sensor would be to see the outputs when placed at different spots on the body like the armpit, behind the ear, and neck. Another test that will be important to do is figure out the range of the RF modules in different environments.

Overall, the testing that was performed proved the functionality of the major sensors and devices. Further testing will reveal the capabilities of each component as well as their limitations. During the next testing it will be important to start testing sensors with one another to see if we can have multiple sensors providing data simultaneously. Eventually a full prototype test will take place in which all of the devices will be connected and working in unison. The transmitting of data to the receiver and displaying it on a monitor will also be a part of future testing.

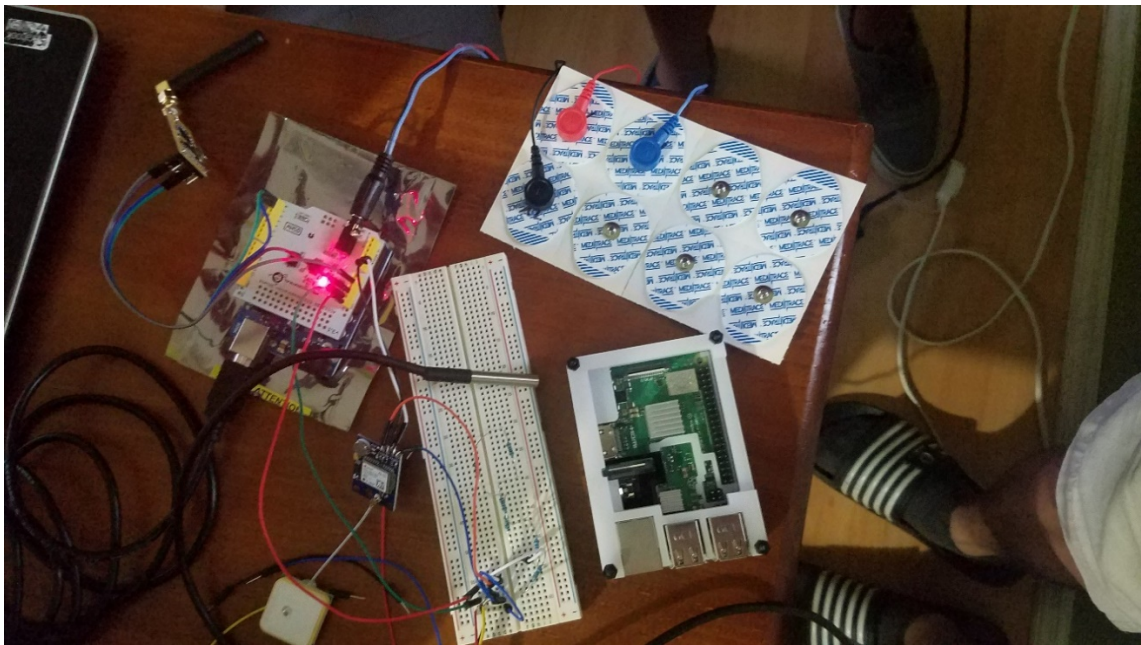

*Figure 76: Breadboard Testing*

## 9.0 Administrative Section

This section serves as a checklist for the team and administration to make sure the project is handled correctly and in a timely fashion. Here will be placed all information administration asks of the team, any issues, and planning devices needed to make sure everything operates according to plan. This includes the planning process and budget allocation.

### 9.1 Planning Process

This table and timeline lay out the planned schedule for this project. The goal for this semester is to complete 120 pages for the report on the M-GU4RD project. The “periods” columns indicate which week of the semester each task is to be worked on and when they are planned to be completed. The tasks are split up based on the submission requirements for the class and the prescribed completion dates match up with the deadlines as indicated by the professor.

## Project: M-GU<sub>4</sub>RD

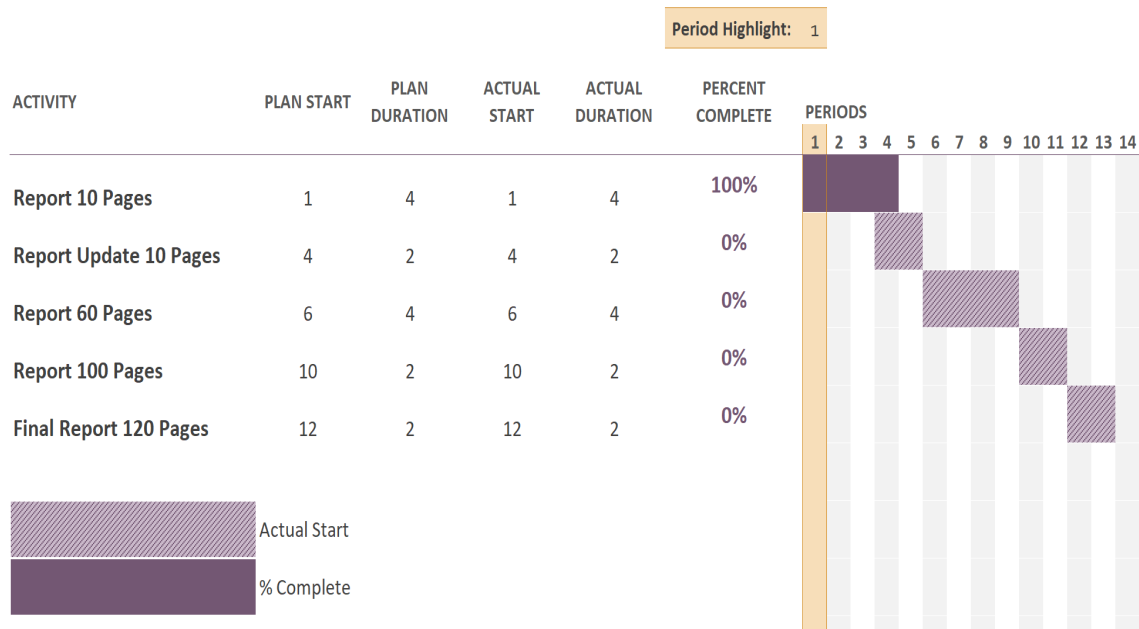

*Figure 77: Milestone Tracking*

### 9.2 Cost Analysis

Financing will be done individually and as a group by Andrew Lucena, Angello Garcia, Giovanni Martinez and Italo Travi.

The following table shows the estimated cost of the project based on the estimated prices for components that will be used.

<b>Component</b>	<b>Estimated Cost (\$)</b>
ECG heart rate sensor	25
Microcontroller	20
Printed circuit board	25
CO2 sensor	60
GPS chip	35
Wifi module	10
PCU	25

*Table 15: Predicted Component Costs*

The table below is representative of the actual components that were bought and their actual costs. In our final design the team decided to drop the use of a CO2 detector as to broaden the design for a variety of first responders and instead a temperature sensor is added to improve vital monitoring. In addition wireless communication will be transmitted via RF module between two microprocessors. One will relay information to the other which displays on a screen.

<b>Component</b>	<b>Estimated Cost (\$)</b>
ECG heart rate sensor	50
Microcontrollers/Microprocessor	60
Printed circuit board	N/A
Temperature sensor	20
GPS chip	25
RF Module	40
PCU	N/A

*Table 16: Actual Component Costs*

### 9.2.1 Changes Made in Senior Design 2

Since the device has been fully developed, a finalized price for research and development was calculated as well as the price for a single unit. The table below shows all of the costs for this project design. The amount of money used in developing the device is well below the budget of the group.

Component	Unit Cost
3.6V Lithium Ion 18650 Battery 2600mAh (x2)	\$7.59
9V 3A AC Wall Adapter	\$10.05
Atmega2560 Chip	\$12.20
NEO-6M GPS Module	\$15.66
ADS1292R ECG/Respiration Shield	\$46.73
DS18B20 Digital Temperature Sensor	\$2.32
APC220 RF Module	\$24.58
PCB	\$18.33
LM2576-ADJ Switching Buck Converter	\$2.03
MCP73832 Battery Management Chip	\$0.57
Resistors/capacitors etc.	\$14.52
<b>TOTAL UNIT COST</b>	<b>\$162.17</b>

*Table 17: Total Unit Cost*

Component	Cost
3.6V Lithium Ion 18650 Battery 2600mAh (x2)	\$15.18
9V 3A AC Wall Adapter	\$10.05
Atmega2560 Chip (x2)	\$24.40
NEO-6M GPS Module	\$15.66
ADS1292R ECG/Respiration Shield	\$46.73
DS18B20 Digital Temperature Sensor	\$15.00
APC220 RF Module	\$24.58
PCB (x8)	\$97.76
LM2576-ADJ Switching Buck Converter	\$4.06
MCP73832 Battery Management Chip	\$1.71
Resistors/capacitors etc.	\$76.64
Battery Holder	\$2.60
5V 3A AC Wall Adapter	\$9.95
TPS61230A 5V Boost Converter (x2)	\$4.12
<b>TOTAL UNIT COST</b>	<b>\$348.44</b>

*Table 18: Total Development Costs*

### 9.3 Milestones

This table shows a much more detailed of the milestones. This was separated into four major sections. The first section was part of the brainstorming to select the idea and the

distribution of work throughout all members. The second section was the research of different types of technologies as well as the overall design of the M-GU4RD. The second section finished with the submission of the 60 pages Report and the revision of Dr.Wei. During the third section the group had to select what device will be utilized in the design. This required not only comparison in performance but also economic and size constraints. Lastly during the fourth section the group test all the selected components and also design the housing for the M-GU4RD, during this part the group also meet multiple times outside the weekly group meetings to review the 120 pages final report.

Number	Task	Date
1	Brainstorm	8/20/2018
2	Bootcamp	8/29/2018
3	Idea selection	9/4/2018
4	Initial Document - Divide and Conquer	9/18/2018
5	Research Major Components	9/19/2018
6	Internal Meeting preparation to 60 pages	11/1/2018
7	Document Review 60 pages with Dr.Wei	11/5/2018
8	Microcontrollers Selection	11/9/2018
9	Sensors Selection	11/10/2018
10	Modules (GPS and RF) Selection	11/11/2018
11	Ordering of Parts	11/11/2018
12	Document Review 100 pages with Dr.Wei	11/20/2018
13	Testing	11/24/2018
14	Case Design	11/24/2018
15	Internal Meeting preparation to 120 pages	11/26/2018
16	Meeting to Discuss 120 pages with Dr.Wei	11/27/2018
17	Final Document Due	12/3/2018

*Table 19: Due Dates*

## 10.0 Conclusion

The M-GU4RD is a revolutionary device providing scope to first-responder tools and mechanisms. This device allows for constant monitoring of those facing dangerous and traumatic situations. The everyday heroes: firemen, police officers, and emergency response deserve protection. Risking their lives for the greater good whether it be fires, enemy combatants, and deathly illness. That is why this device is so important. It's about protecting those who rescue others so that everyone can be safe and healthy. Reducing the amount of unwarranted deaths by monitoring their location and vitals saves lives.

Many of these first-responders are also dealing with trauma at home. After a tough day of work these brave men and women have seen it all. The injuries, the death, it takes a toll. This can result in death in the following hours. Many first-responders keep fighting even after the action due to PTSD, internal injuries that may go unchecked, and heart-attacks overnight. Some even result to suicide. The M-GU4RD doubles as a safety precaution to monitor people over the next 24-hours after an emergency engagement. This device is very flexible and can adjust and address multiple issues. Including saving those within the "Golden Hour".

In final analysis, the M-GU4RD project is a device meant to monitor the vitals and location of first responders for safety reasons. The device is designed to measure heart rate, respiratory rate, body temperature, and position and send this data to someone who can monitor the individual. The design uses sensors to measure this data and a microprocessor arranges the data cohesively. This packet of information is transmitted using a RF module to a receiver that can be plugged into any Windows laptop or tablet. The information can be displayed on the Windows application.

This project thus far focused on what major components were to be used as well as the testing of said components and design. All of the major sensors and devices were tested individually to prove functionality and accuracy. After testing was complete, all the sensors demonstrated successful results to utilize them for the final product. Further testing will take place to combine all of the components together and to test PCB designs. If time permits, the group will work on additional features including altitude sensing and gas detection.

# 11.0 Appendices

This section will include the bibliography which contains all the material referenced as well as a permission section with screenshots of the emails sent to the different websites and companies regarding the usage of images from their website and products.

## 11.1 Bibliography

- [1] “Altimeter.” *Wikipedia*, Wikimedia Foundation, 13 Oct. 2018, en.wikipedia.org/wiki/Altimeter.
- [2] Balanis, Constantine. *Antenna Theory: Analysis and Design*. Wiley-Interscience, 2016.
- [3] Choudhary, Himanshu. “Difference between Microprocessor and Microcontroller.”
- [4] Electronics, Jameco, director. *Designing Your Own PCB*. *YouTube*, YouTube, 28 Oct. 2014, www.youtube.com/watch?v=Va\_NcvcZXps.
- [5] *EngineersGarage*, EngineersGarage, [www.engineersgarage.com/tutorials/difference-between-microprocessor-and-microcontroller](http://www.engineersgarage.com/tutorials/difference-between-microprocessor-and-microcontroller).
- [6] “GPS Buying Guide.” *COM-14646 - SparkFun Electronics*, [www.sparkfun.com/pages/GPS\\_Guide](http://www.sparkfun.com/pages/GPS_Guide).
- [7] “Guide for DS18B20 Temperature Sensor with Arduino.” *Random Nerd Tutorials*, randomnerdtutorials.com/guide-for-ds18b20-temperature-sensor-with-arduino/.
- [8] “Guide to NEO-6M GPS Module with Arduino.” *Random Nerd Tutorials*, randomnerdtutorials.com/guide-to-neo-6m-gps-module-with-arduino/.
- [9] ISO. “ISO/IEC/IEEE 29119 Software Testing.” 10 Sept. 2014, *ISO/IEC/IEEE 29119 Software Testing Standard*, softwaretestingstandard.org/.
- [10] “Lithium-Ion Battery.” *Wikipedia*, Wikimedia Foundation, 26 Nov. 2018, en.wikipedia.org/wiki/Lithium-ion\_battery.
- [11] Protocentral. “Protocentral/ADS1292rShield\_Breakout.” *GitHub*, 4 July 2018, github.com/Protocentral/ADS1292rShield\_Breakout.
- [12] Buckley, Ian. “6 Best Arduino Alternative Microcontrollers.” *MakeUseOf*, 2 Feb. 2018, [www.makeuseof.com/tag/best-arduino-alternative-microcontrollers/](http://www.makeuseof.com/tag/best-arduino-alternative-microcontrollers/).



- [13] Labs, MET. “UN/DOT 38.3 Transportation Testing Required for Lithium Battery Safety During Shipping.” *MET Laboratories, Inc.*, Compliance Today, 30 Aug. 2017, [www.metlabs.com/battery/un-38-3-transportation-testing-required-for-lithium-battery-safety-during-shipping/](http://www.metlabs.com/battery/un-38-3-transportation-testing-required-for-lithium-battery-safety-during-shipping/).
- [14] Qureshi, Asim. “10 Best Microcontroller Boards For Hobbyists And Engineers.” *Wonderful Engineering*, 4 Sept. 2015, [wonderfulengineering.com/10-best-microcontroller-boards-for-hobbyists-and-engineers/](http://wonderfulengineering.com/10-best-microcontroller-boards-for-hobbyists-and-engineers/).

## 11.2 Permissions

GADGETS
CARS BIKES
ROBOTICS
TECHNOLOGY
ARCHITECTURE
MILITARY TECH
BIOMEDICAL
DIY PROJECTS
NEWS

**Do you have other questions? Don't worry, there aren't any dumb questions.**

Just fill out the form below and we'll get back to you as soon as possible (usually within one business day).

Your Name (required)

Angello Garcia

Your Email (required)

angellogarcia@knights.ucf.edu

Subject

Permission to use images

Your Message

Hello,

my name is Angello Garcia and I am currently an student from UCF majoring in Electrical Engineer. I would like to ask for permission to utilize some images found in your website. Specifically the ones in the article "10 best RF Modules for Arduino" Thank you very much!

SEND

### Permission to use image



**Angello Garcia** <angellogarcia@Knights.ucf.edu>

8:34 PM



To: techsupport@arcadianinc.com

Hello,

my name is Angello Garcia and I am currently an student from UCF majoring in Electrical Engineer. I would like to ask for permission to utilize some images found in your website. Specifically the one for “**IP-65 Rated Outdoor 868 & 915 MHz Antenna with SMA Male Connector**” this will be included in my senior design project.

Thank you

## RE: Permission to use image



Michael Crudele <mikec@arcadianinc.com>

11/29/2018 5:51 PM

To: Angello Garcia

Angello,  
You may use this image.  
All the best,  
Mike

**Mike Crudele**  
*President & Antenna Specialist*



1-973-200-5590 | Direct Line

1-973-477-7764 | Mobile

[mikec@arcadianinc.com](mailto:mikec@arcadianinc.com)

[www.arcantenna.com](http://www.arcantenna.com)



### **Stocking Distributor for:**

Antennas from: RFMAX, Laird, Pulse, Times-7, MTI, AirGain  
RF cable assemblies, surge protection, enclosures & mounts

From: angellogarcia@Knights.ucf.edu



To: [thomas.olshanski@fema.dhs.gov](mailto:thomas.olshanski@fema.dhs.gov);

Cc & Bcc

### Permission for Images

Hello,  
my name is Angello Garcia and I am currently an student from UCF majoring in Electrical Engineer. I would like to ask for permission to utilize some images found in your website. Specifically the ones in the article "PPE use and unsafe actions by firefighters"

Thank you

Sent from [Mail](#) for Windows 10

  
**OLIVET**  
NAZARENE UNIVERSITY

Welcome to Live Chat! Please enter your name, email, and optional question to begin.

Your Name

Your Email

Your Question

**SEND**



Michelle: [12:51:27 PM] Welcome to our live chat support.  
How may I help you today?

Angello Garcia: [12:51:27 PM] Hello, my name is  
Angello Garcia and I am currently an student  
from UCF majoring in Electrical Engineer. I  
would like to ask for permission to utilize some  
images found in your website for our Senior  
Design Project Thank you

Michelle: [12:51:46 PM] Hello Angelo.

[12:51:53 PM] I am unable to assist you with this.

[12:52:08 PM] Please call our main number at  
877.965.4838.

00:47

\*The call was made and accepted