

Table of Contents

1	Executive Summary	1
2	Project Description	2
2.1	Members	2
2.2	Narrative	2
2.3	Design Specifications	3
2.4	House of Quality	5
3	Project Research	
3.1	Existing Projects and Products	8
3.1.1	Pyxis MedStation™ System	8
3.1.2	CompuMed Plus Automatic Pill Dispenser	9
3.1.3	LiveFine Automatic Pill Dispenser	10
3.2	Market Analysis	11
3.3	Relevant Technologies	12
3.3.1	Servo Motor	12
3.3.2	Rechargeable Battery Pack	13
3.3.3	LCD Screen	15
3.3.4	Voltage Regulators	15
3.3.5	Bluetooth Module	15
3.3.6	Security Sensor	17
3.3.7	Microcontroller	17
3.3.7.1	Microcontroller Programming	17
3.4	Component Research and Selection	18
3.4.1	Display Technologies	18
3.4.2	LCD Screens	20
3.4.3	Speakers	21
3.4.3.1	Surface Transducer	21
3.4.3.2	PCB-Mounted Speaker	22
3.4.3.3	Piezoelectric Buzzer	22
3.4.4	Wireless Communication	22
3.4.4.1	Wi-Fi	23
3.4.4.2	Infrared	23
3.4.4.3	Radio Frequency	24
3.4.4.4	Bluetooth	24
3.4.4.4.1	HC-05 Bluetooth Module	25
3.4.4.4.2	RN-42 Bluetooth Module	25
3.4.4.4.3	CC2650	26
3.4.5	Pill Dispensing Technology	26
3.4.6	Power Supply	28
3.4.6.1	Batteries	28
3.4.6.2	Charging Mechanisms	30
3.4.6.2.1	Simple Chargers	31
3.4.6.2.2	Trickle Chargers	31

	3.4.6.2.3	Smart Chargers	31
	3.4.6.2.4	USB Chargers	31
	3.4.7	Security Sensors	33
	3.4.7.1	Infrared Sensor	33
	3.4.7.2	Magnetic Sensor	34
	3.4.8	Microcontroller Selection	34
	3.4.9	LED Selection	37
	3.4.10	Programming Interface	38
	3.4.11	UART MUX	39
	3.4.12	PWM	39
	3.4.13	Locking the Device	39
4	Related Standards and Realistic Design Constraints		42
4.1	Related Standards		42
4.1.1	HIPAA Regulations		42
4.1.2	Impact of HIPAA Regulations		43
4.1.3	ISO/IEC/IEEE 9945:2009		43
4.1.4	ISO/IEC 9899		43
4.1.5	IEEE 2003.1b-2000		43
4.1.6	Impact of IEEE C-Programming Standards		44
4.1.7	ISO/IEC/IEEE 29148		45
4.1.8	Impact of ISO/IEC/IEEE 29148		45
4.1.9	IPC PCB Standards		46
	4.1.9.1	IPC-2221B	46
	4.1.9.2	IPC-2220	46
	4.1.9.3	IPC-6011	46
4.1.10	Impact of IPC PCB Standards		47
4.1.11	IEEE 1625-2004 Battery Standards		47
4.1.12	Impact of Battery Standards		47
4.1.13	IEEE 802.15.1 Bluetooth Standard		47
4.1.14	Impact of IEEE 802.15.1 Bluetooth Standard		48
4.2	Realistic Design Constraints		48
4.2.1	Pill Type Dispersal Constraint		48
4.2.2	Charge Capacity and Power Consumption Constraint		49
4.2.3	Size and Portability Constraint		50
4.2.4	Economic and Time Constraint		50
4.2.5	Safety		51
5	Project Hardware and Software Design Details		54
5.1	Hardware Design		54
5.1.1	Block Diagram		56
5.1.2	Programming the MCU		58
5.1.3	Battery Charger		59
5.1.4	Power Distribution		64
5.1.5	CC2650 MCU Layout		70
5.2	Software Design		74

5.2.1	Programming Language	74
5.2.1.1	Python Programming Language	74
5.2.1.2	Java Programming Language	74
5.2.1.3	C Programming Language	75
5.2.1.4	Language of Choice	75
5.2.2	Software Functionality	75
5.2.2.1	Pill Dispensing Mechanism	76
5.2.2.2	Notification System	77
5.2.2.2.1	Bluetooth Notifications	77
5.2.2.2.2	LED (Visual) Notification System	80
5.2.2.2.3	Audible Notification System	80
5.2.2.3	Security Alert System	81
5.2.2.4	LCD Display	82
5.2.2.5	Servo Motor	83
5.2.3	Algorithm Description	84
5.2.3.1	Pill Dispenser Functions	84
5.2.3.2	Notification System Functions	85
5.2.3.3	Security Notification Functions	85
5.2.3.4	LCD Display	86
5.2.3.5	Servo Motors Functions	87
5.2.4	Pill Disbursal Flow Chart	87
5.2.5	Software Requirements Traceability Matrix	88
5.2.6	Class Diagram	89
6	Prototype Construction and Coding	91
6.1	Printed Circuit Board	91
6.1.1	PCB Design	92
6.1.2	PCB Software	92
6.1.3	PCB Design Techniques	94
6.1.4	Thermal Management	95
6.2	Potential Concerns	96
6.2.1	Hardware	96
6.3	Prototype Constraints	97
6.4	Software Constraints	97
6.4.1	Static Programming of LCD Display	97
6.4.2	Unfamiliarity with the Bluetooth Programming	98
6.4.3	Software Version Control and Prototyping	99
6.5	Mounting PCB and Components	100
6.5.1	Mounting PCB	100
6.5.2	Mounting the Battery Pack	102
6.5.3	Mounting LCD Screen and Small Components	102
6.6	Internal Design of Device	104
6.6.1	3D Printing Material	105
6.6.1.1	Plastics	105
6.6.1.2	Metals	106
6.6.1.3	Other Materials	107

	6.6.1.4	The Material of Choice	107
	6.6.2	3D Design of Device	107
	6.6.2.1	Blender	108
	6.6.2.2	SketchUp	108
	6.6.2.3	SolidWorks	108
7		Project Prototype Testing Plan	109
	7.1	Hardware Testing	109
	7.1.1	Hardware Specific Training	109
	7.1.2	Microcontroller Testing	110
	7.1.2.1	Power Supply Testing	111
	7.1.3	Buzzer and LED Testing	113
	7.1.4	Servo Motor and Security Sensor Testing	113
	7.1.5	LCD Testing	115
	7.2	Software Testing	115
	7.2.1	Unit Testing Strategies	116
	7.2.2	Amount of Testing	118
	7.2.3	Software System Testing	119
	7.2.4	Integration Testing Strategies	121
	7.2.4.1	Top-Down Integration Testing	121
	7.2.4.2	Big Bang Integration Testing	121
	7.2.4.3	Bottom-Up Integration Testing	122
	7.2.5	Integration Testing Hierarchy	122
	7.2.6	Test Description Chart	123
8		Administrative Content	126
	8.1	Budget and Finance Discussion	126
	8.2	Milestone Discussion	127
	8.2.1	Senior Design 1 Milestones	127
	8.2.2	Senior Design 2 Milestones	128
9		Conclusion	130
	9.1	A Look Forward to Senior Design 2	130

Appendices

Appendix A - References

List of Figures

Figure 1: Simple Sketch of Medlock Device.....	3
Figure 2: Pyxis MedStation 4000.....	9
Figure 3: Servo Motor Diagram.....	13
Figure 4: Lithium-Ion Battery Pack Circuit.....	14
Figure 5: Bluetooth Mapping on MSP430 Launchpad.....	16
Figure 6: Magnetic Sensor Diagram.....	17
Figure 7: 8x8 LED Dot Matrix.....	19
Figure 8: OLED Screen.....	19
Figure 9: HC-05 Bluetooth Module and RN42 Bluetooth Module.....	26
Figure 10: Simple Schematic of Pill Dispenser.....	27
Figure 11: 9-Gram Servomotor.....	28
Figure 12: Functional Block Diagram.....	35
Figure 13: 5mm LED.....	38
Figure 14: Tubular Pin Tumbler Lock.....	40
Figure 15: Pin and Tumbler Lock.....	40
Figure 16: Group Member Responsibility Diagram.....	57
Figure 17: Overall Battery Protection Scheme.....	58
Figure 18: Battery Charger Schematic.....	60
Figure 19: BQ25606 Internals.....	62
Figure 20: Main portion of the First Supply.....	65
Figure 21: Load Layout of the First Supply.....	66
Figure 22: Top: Regulator setup with values Bottom: Loads attached to regulator output	66
Figure 23: Fourth Voltage Regulator.....	68
Figure 24: Fifth Voltage Regulator.....	68
Figure 25: Overview of Power Distribution.....	69
Figure 26: MCU to LCD and IR Sensor.....	71
Figure 27: MCU to LEDs, Buzzer, and Servor Motor Units.....	73
Figure 28: GAP State Diagram.....	77
Figure 29: Connection Event and Interval.....	79
Figure 30: Pill Disbursal Flow Chart.....	87
Figure 31: Software Class Diagram.....	90
Figure 32: Equation Resistance of Traces.....	94
Figure 33: Equation Voltage in an Inductor.....	95
Figure 34: Slot Mount.....	100
Figure 35: Inside of Casing.....	105
Figure 36: Static Power Consumption Equation.....	111
Figure 37: Active Mode Current vs. Temperature.....	111
Figure 38: Power Consumption Equation.....	112
Figure 39: Power Consumption Equation.....	112
Figure 40: Current Consumption vs. Supply Voltage.....	112
Figure 41: Dynamic Power Consumption Equations.....	113
Figure 42: Testing Classification Tree.....	118
Figure 43: Software Hierarchy.....	123

List of Tables

Table 1: House of Quality.....	6
Table 2: House of Quality Legend.....	7
Table 3: LCD Screen Table.....	20
Table 4: HC-05 Module Specifications.....	25
Table 5: RN-42 Module Specifications.....	25
Table 6: Battery Comparisons.....	29
Table 7: USB Type Comparisons.....	32
Table 8: USB Version Comparisons.....	32
Table 9: Microcontroller Comparisons.....	36
Table 10: Software Requirements Traceability Matrix.....	88
Table 11: PCB Software Comparisons.....	93
Table 12: Test Description Chart.....	123
Table 13: Part Pricing.....	126
Table 14: Senior Design 1 Milestones.....	127
Table 15: Senior Design 2 Milestones.....	128

1. Executive Statement

“In the United States of America on average 91 people die a day from opioid overdose. Prescription drugs are a driving factor for this number, with the amount of prescription opioids sold to pharmacies and hospitals nearly quadrupling from 1999-2010[1, reprinted with permission from CDC].” This has truly become a major issue in the United States, with overdoses and the illegal sale of prescription drugs occurring every single day, we need to begin looking for a solution. The solution to the problem needs to start at the source, the place where all these prescription drugs are dispensed, pharmacies.

Most people can identify a prescription drug container. That orange container topped with the white lid and wrapped with the matching label, the label always containing a long name that only those in the medical field seem to be able to announce. The problem is obviously not easily solved or it wouldn't be a problem. Our group believes that if you can make the pills only available a few at a time, with real consequences for abusing them then and only then can you start to put a dent in that 91 a day number.

Our devised solution is called Medlock, a pill disbursement system that only allows for the proper dosage to be dispensed at a time. Now you may be saying “those already exist you can buy them and fill them yourselves”, therein lies the problem. Someone who is at risk of overdose would have to trust themselves to fill it and would be able to have the key to open such a thing. What differentiates the Medlock is that in the envisioned scenario the Medlock would be filled and regulated by the pharmacists, with strict regulations against the breaking or opening of the case.

The Medlock will include a magnetic sensor that when connected to the PCB will record every time the case has been opened. This allows for the pharmacist to identify which users may have opened their cases for improper reasons. With that system in place then pharmacies would be able to identify at risk patients and either require them to go to rehab or not allow them any future refills. Along with the enhanced security features the Medlock will include multiple types of notifications to help users remember to take their needed medication.

The United States has many major problems, with one being the abuse of prescription drugs. The goal of the Medlock is to combat this problem head on in the best possible way. If something is not done then this issue will linger and most likely get worse. With that being the case combating this issue should be a priority within the United States. Overall the purpose of the Medlock is to help to not only lower the casualties caused by the use of prescription drugs, but to also help to further regulate the selling and general misuse of prescription drugs across the nation.

2. Project Description

2.1 Members:

Here are the members taking Medlock the step from a plausible concept into a universal reality. This team is comprised of two computer engineers and two electrical engineers to fulfill both the hardware and software aspects. As a team, the goal is to understand the essentials of engineering and to take the first real step into this ever-changing profession. This project is being funded and sponsored by a private sponsor.

Nicholas Macri: CPE

Cray Winfrey: CPE

Shanice Dublin: EE

Nicholas Arnold: EE

2.2 Narrative

In the United States, the abuse and illegal distribution of prescription drugs is a large-scale problem. Without measures in place to stop such actions the problem will never be ended. So, the question becomes what actions can be taken to make steps toward a solution, in comes the Medlock (Patent Pending). In hospitals, there are machines that manage the distribution of medicine so that the nurses or patients cannot steal medication. This idea has yet to be extended to a personal home system, this is our proposed idea. A portable system that regulates the use and dosages of prescription drugs in an effort to reduce abuse as well as the selling of such drugs. Although this device is more aimed towards trying to help stop opioid addiction, it can also serve a purpose for those who often forget to take their medication. In the end, this device is designed to help regulate and monitor the prescription drug industry.

This project is sponsored by an outside party and many of their specifications are built into the schematic of the device. This product is to be similar to receiving a prescription from the pharmacy with many additional safety measures. There will be a casing that encloses the pills along with electrical components and a disbursal mechanism. There will be an LCD display that acts like the label on an ordinary pill bottle that shows the patient's name, dosage, medicine type, etc. The mechanism will allow a pill to be distributed every time the patient is required to take their dosage of medication. There will be a notification system to remind the patient when the pill is ready as well as a software mechanism to update the time of the disbursal of the next pill based on when the previous is taken. On top of this is, a lock, tape on the casing, and well as a magnetic sensor will be used to determine if the case has been broken into and if so the case will no longer be eligible for refills.

The main goal for this project is to develop a light weight, portable, and easy to use device that will help stop addiction as well as illegal sales of prescription drugs. We feel that this is an accomplishable project that could create a real impact in many people's lives today. Overall the idea of Senior Design is to get some hands-on experience with real world applications and apply the knowledge that we have obtained in our college career to develop, test, and present a working device. We figured if we could do this while also creating a product that can truly help the world then the experience would become even more meaningful. A sketch of the exterior view of the device is shown below.

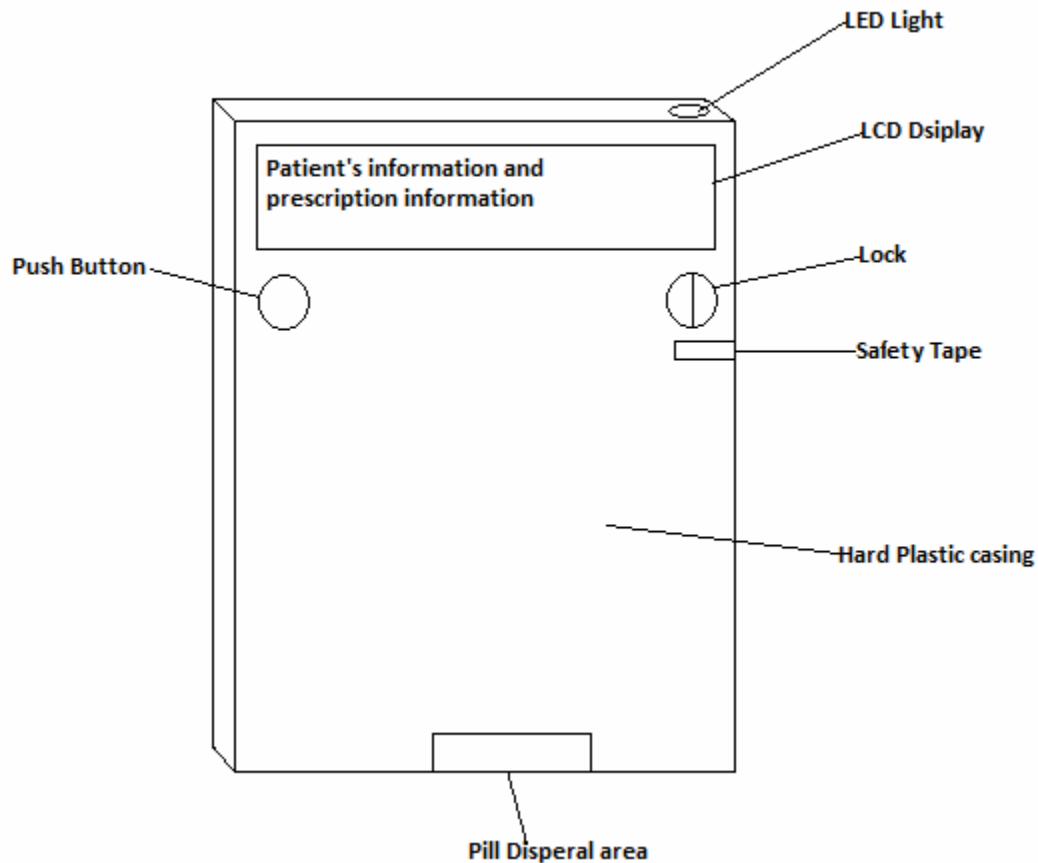

Figure 1: This figure is a custom simple sketch of the outside of the device, showing what components will be visible from the outside.

2.3 Design Specifications

The items below show the specifications of Medlock to be achieved as well as the constraints of implementing them.

Specifications:

- Size of device: Goal, 6 by 3 by 2 inches, realistic size 12 by 6 by 4 inches.
- LCD display: Shows patient's name, type of medicine, dosage, how often medication must be taken.

- Bluetooth connection: Phone will be able to connect to the device via Bluetooth so messages can be sent from the device to the patient's phone.
- Piezo buzzer: Releases an audible sound if the patient has not taken their medication in a specific time frame.
- Pill release mechanism: Small mechanism to ensure that the proper amount of pills have released at the proper time.
- Notification system: Device would have audible, visual, and mobile alerts as to when the patient needs to take their medication.
- Pill not taken system: Software that updates the time if the patient has not taken pill in specified range of time. This is to avoid over dosage and selling of pills.
- Button to release pill: Physical button that patient presses to release pill once alerted.
- Seal on container: Physical lock on device door, authorized colored tape to determine if device has been tampered with, as well as sensors that record when device has been opened.
- Software to determine if refill is needed: When device is filled, the number of pills in device is recorded as an input, every time a pill is dispensed; one is subtracted from that number.
- Light Sensor: On the inside of the case to determine if the case has been opened.
- Infrared Sensor: Logs every time the device has been opened.
- Sensor for proper pill amount: A mechanism will be designed that ensures the proper number of pills has been release, unsure at this point.
- Microprocessor: This will be used to keep track of time, date, and number of pills. Will also be used for notifications of when patient needs to take medication.
- PCB: Holds electronic components for communication between sensors, displays, and the CPU.
- Power source: Battery source that can be charged.

Constraints:

- Some known constraints at this point include the following:
- The device is only going to be able to contain one type of pill at a time.
- The device must be charged daily in order for patient to receive medication on time.
- The size of the device is aimed to be small, but in a realistic term the device is most likely going to be a little more bulky than original thought.
- The material used in the prototype is going to differ from the final product. The prototype material will be cost efficient for us, so it will not be the ideal material for this device.

2.4 House of Quality

When it comes to meeting expectations/specifications, perfection cannot be entirely achieved, especially when creating the first prototype of a device or invention. There needs to be certain compromises to ensure that what is being made meets what the customer is looking for as well as fulfilling credible requirements for the engineer in terms of quality and reliability. To represent this concept in a quantitative fashion, the use of the house of quality within a method of quality function deployment (QFD) would be useful.

The first step to creating this house of quality is to gather as much of the customer concerns and wants as possible. This should be considered the most crucial step to create and pay attention to since this is the reason the product is developed to begin with. Simply put, it is the selling point for the product to make it as desirable as possible. So far, it's known that the customers want:

- Compact
- Cost
- Security
- Ease of use
- Safety
- Attractive

Normally, a planning matrix would be created next which would categorize the importance the customer had with each of the keywords above via a survey weighing each task on a scale. However, for the sake of simplicity, the priority list is represented by pluses and minuses.

The following part of the house creates the technical requirements to be carried out. These factors not only show what they are confident in accomplishing but it provides the customer with a contract to let them know that these items are what the engineer is accountable for. This can be, but are not limited to:

- Cost
- Power consumption
- Push Notifications
- Weight
- Reliability
- Sensitivity
- Security

Next, connecting the customer requirements with the technical requirements gives an overview of which items are to be considered more important to work on in relation to each other by the development team which is represented in the diagram below. Through this matrix, it should be understood which aspects create a strong relationship and if improving one would benefit the other in any way. Anywhere there is no symbol in the matrix; there is no foreseen positive or negative relationship when comparing the two items.

Moving on to the roof of the house shows which items from the technical list will either hinder or improve up the quality of other attributes of the technical requirements. This is shown by the pluses and minuses in his triangle of the root matrix. For example, increasing the sensitivity of the product could mean more

precise and accurate materials to buy, meaning that the cost would increase as well, which isn't something that is wanted hence the minus in the top tile. The House of Quality (Table 1) along with its legend (Table 2) is shown below.

		Cost	Power Consumption	Weight	Reliability	Sensitivity	Security	Push Notifications
		-	-	-	+	+	+	+
Compact	+	↑↑		↑↑				
Cost	-	↑↑	↓	↑	↓	↓	↑	↓
Security	+	↑			↑↑		↑↑	
Ease of Use	+			↑↑				↑↑
Safety	+		↑	↑			↑↑	
Attractive	+	↓↓						↑
		\$100 min	< 5 W	< 2 lbs	3 Years, pill drops on time	<1% clock error	Identify when case has been opened.	Blue-tooth notifications sent within 2 minutes of pill being ready.

Table 1: House of Quality

Legend	
↑↑	Strong Positive Relationship
↑	Positive Relationship
↓	Negative Relationship
↓↓	Strong Negative Relationship
+	Needs to Maximize
-	Needs to Minimize

Table 2: House of Quality Legend

3. Project Research

In this section, we will discuss the pill dispenser marketplace along with technologies relevant to the research and the process of part selection for our own project. The medical field is a robust and competitive field therefore there are depths of knowledge involving most issues within the field. In this section, existing projects from high scale pill distribution machines to home use machines will be examined. Then further information will be displayed about the technologies relevant to our individual project ranging from the use of Bluetooth to the battery pack to what is behind the physical dispensing of our pill. The final section of our research will be the choices we made for the parts that will be used in the project and the reasons behind those choices. Overall this section will give insight into the beginning steps of our project which is scholarly research.

3.1 Existing Projects and Products

As is the case with most technology today, the idea is not typically 100% original. More than likely most new technologies are just innovative approaches taken to improve the ability and effectiveness of previously created ideas. This would be true in the case of our project. For years people have been searching for ways of improving the process of pill distribution and consumption, whether it be to help remind people when they need to take their pills or to stop the abuse of pills. Our project aims to do both, it is intended as a pill dispenser that targets the major issue of prescription drug abuse, as well as acting as a reminder system to tell patients when their medicine is ready. Now as stated previously most “new” technologies in today's world are usually variations of past products that aim at improving or adding functionality. In this section, we will examine 3 existing products that have similar ideas to our project (Medlock). The three products that will be reviewed are the “Pyxis MedStation™ system”, the “CompuMed PLUS Tamper Resistant Automatic Pill Dispenser”, and the “LiveFine Automatic Pill Dispenser.

3.1.1 Pyxis MedStation™ System

The Pyxis MedStation™ is a system used within hospitals for pill separation and distribution. The system uses barcode scanning technology, this assures that the correct medication and dosage is chosen and supplied. The systems benefits are numerous, from the easy to use interface to the regulation of the pill distribution and inventory updating. This system is widely used in hospitals throughout the country. The way this system works is that it has a computer interface connected to an inventory system, which is directly connected to the computer. The nurse or doctor will first have to use a fingerprint scanning device to get into the system, this prevents use of the system by non-approved people. Following that the nurse or doctor can then scan the prescription barcode and the system will in most cases open for quick access to the prescription (not every single medicine

is stored in the cabinet at all times). For medicines that aren't stored in the cabinet an order will be put in through the system. Also for drugs that require additional information when administering the system will provide additional checks (for instance "are you sure this is the dosage") to make sure that there is no mistake that could prove costly to the patient's health.

The CareFusion corporation makes this product, it retails for over \$10,000 (couldn't find the price on the CareFusion website, found pricing of second hand one for \$16,000). This kind of pricing makes sense due to the fact that it is for hospital use with large scale pill distribution and management purposes. Overall the product is an accomplished system which has various benefits for hospital environments. It prevents the stealing of drugs, regulates the distribution while lowering error, and lastly according to the CareFusion corporation "streamlines the prescription process, reducing time used on inventory and prescription distribution" [2, reprinted with permission from BD]. In Figure 2 below, you can see the typical Pyxis MedStation™ 4000 configuration. Our project will attempt to replicate some of the aspects of this product but on a smaller at home type of scale. With the main idea being to avoid the misuse of prescription drugs whether the user is doing it knowingly or unknowingly.



Figure 2: Pyxis MedStation [2, reprinted with permission from BD]

3.1.2 CompuMed Plus Automatic Pill Dispenser

The second product that we will discuss is far more comparable to our project idea. This product is called the "CompuMed Plus Tamper Resistant Automatic Pill Dispenser". This dispenser comes with a security lid and padlock and is mostly used for class II narcotics and pain medications. This has a loadable capacity of a week's supply of pills and dispenses pills up to 4 times a day. This is designed with tamper resistance for drug rehabilitation purposes. The way that

this device works is first the weekly supply must be set up, this is done by loading the pills into a tray that slides into the device. Once the tray is loaded into the device it is then locked into place with a key, then a security lid is placed over top of the tray and locked into place using a padlock. From that point on the alarms and pill taking time is programmed into the dispenser using the buttons on the front, from then on, the pills will be set to dispense at those same times each upcoming day. The alarm will sound continuously until the pill is removed. The product also comes with 4 keys for the various locks, as well as a battery backup that can last up to two weeks.

This product retails for between \$780(epill.com)-\$850(Amazon). The CompuMed product offer many of the same functionalities as our proposed product, such as tamper-proofing, a notification/alarm system and a battery backup. How these features are implemented will be different, such as the use of a special colored tape and magnetic sensor for our tamper-proofing. Ideally if all went to plan with our proposed system the advantages would be firstly, the pharmacy would fill our product (Medlock) with the prescribed pills making the possibility of tampering before the pills are loaded far less likely. The second advantage would be the price, if the product was properly regulated then the building of the product would be less and therefore the market price would be lower than that of the CompuMed product.

3.1.3 LiveFine Automatic Pill Dispenser

The 3rd product is an automatic pill dispenser mad by LiveFine. This product is described as “great for seniors and caregivers. This dispenser holds up to a 28-day supply of pills and can dispense pills up to 6 times a day. Like our proposed project as well as the CompuMed dispenser there is a pill notification system. This notification system is self-programmed and has both audio and visual alerts that will last up to 30 minutes when the pills are to be taken. This design has a spherical shape with 28 slots containing pills surrounding the timer and notification system in the middle. This design also comes with a motorized system to rotate the slots so that each one will go under the opening in which the pills can be taken. The last major feature of this product is the optional latch with a manual key to help to prevent accidental overdose.

This product is far different from the previous two we explored in this section. The major difference is that the retail price is \$79.95. This shows that many of the same functionalities can be implemented at a much lower cost. Obviously the other two products are different from LiveFine’s pill dispenser, the Pyxis machine is much more of a large-scale machine which has major importance within the hospital system. That being the case you would expect the asking price to be high because for as much use as it sees, the money will almost assuredly be worth it. As for the CompuMed product it could be considered very similar to LiveFine with the key difference obviously being the level of security installed. The importance of the security is obviously the calling card for that product and

probably the reason for the cost. Medlock, our project, probably falls somewhere in between the final two products in this section. In that it shares much of the capabilities of both, but with a possibly more efficient security system than LiveFine and a much lower planned price than CompuMed. The ideal situation for our project is to fill a specific niche and hopefully replace pill containers in pharmacies.

3.2 Market Analysis

The healthcare marketplace has always been an area of large growths and major competition. With so much new technology and expertise being developed every single day new ideas and medical supplies often appear out of the woodworks, knowing that any new treatment or product could possibly save a person's life. This kind of growth and importance are heavy drivers of competition across the medical marketplace. The pill distribution and regulation industry proves to be no different.

With the problem of prescription drug abuse running rampant, many companies and corporations are searching diligently for a solution to this issue. We saw some different ideas and examples of this in the previous section. With the market being so flushed with ideas and possible choices, any new product needs to find a niche or a way to differentiate itself from the pack. Sometimes finding the correct place to target is more important than the overall effectiveness of your product.

Our project, the Medlock system is attempting to insert itself into a specific niche in the industry. The idea is to replace the pill bottles given to you at the pharmacy with our product. The idea being in the most part used for heavily abused drugs such as painkillers and such. There are many at home products already that are designed with the idea of stopping the abuse of narcotics in mind. The largest problem with these products is that unless someone is there to specifically help the person, the product is useless. The thought being that the person who is receiving the prescription would then have to fill the locking or secure dispenser that they have bought, so that they can't get to all the pills at once and therefore can't abuse them. The issue with this process is first a possible addict would have to resist enough to load the dispenser, then the second major problem is the fact that in most scenarios that same addict would then have the key to unlock said pill dispenser at any point in time making the whole process somewhat moot. Therefore, the only effective way for such products to work would be to have someone fill it for the person receiving the pills. This is where our idea comes into play.

Our project is specifically designed to combat the abuse of prescription drugs. The plan to make this happen is to get this into the pharmacies. The best way to stop something like prescription drug abuse is a systematic approach. If a

product is made that can replace pill bottles and be portable and user friendly then pharmacists won't have a problem with using it. This is the niche in the market that we hope to fill with our project. The way this is done is with quick refill mechanisms such as pre-designated disbursement methods in which a replacement set can be put in quickly like a Pez dispenser. Now this obviously doesn't solve the problem of drug abuse, but that is where the use of mechanisms such as a magnetic sensor comes in. Basically, you put a magnetic sensor in the case and you can track if the case has been opened or not. If it is the case that someone has broken into their pill dispenser then no refills will be given from then on by the pharmacists.

Understandably there are probably many doubts in this plan, obviously the product would have to be fantastic with cheap production costs and show that it effectively combats the problem for it to be accepted in the way we plan it. The good news is though; if all does not go as plan then Medlock can be marketed similar to the "LiveFine Automatic Pill Dispenser" discussed in the previous section. It can be used to try and securely protect against drug abuse or in a more practical way such as a reminder system for senior citizens or just forgetful people in general. Overall there is an intended use that is our ultimate goal for the project, the good news is if that ideal use doesn't come to fruition then there is always the fallback as a competitive product in reminding people of all ages to take their pill on time. The medical market is ultimately a battlefield in which many companies are trying to make the best products for a better price, and we are just trying to find the correct niche.

3.3 Relevant Technologies

The purpose of this section is to have a basic outline of the technology needed in order for the design of the dispensary to function. This provides a fundamental understanding of what product is being made and the general specifications needed to fulfill the requirements of construction. Major components such as the microcontroller, servo motors, and screens as well as smaller, but not insignificant, components like regulators and sensors will be discussed below.

3.3.1 Servo Motor

A servo motor is defined as a motor that makes use of negative feedback in order to control motor speed as well as position. There are two main types of servo motors, those being positional rotation and continuous rotation. Figure 3 below shows a diagram of the servo motor and how it operates.

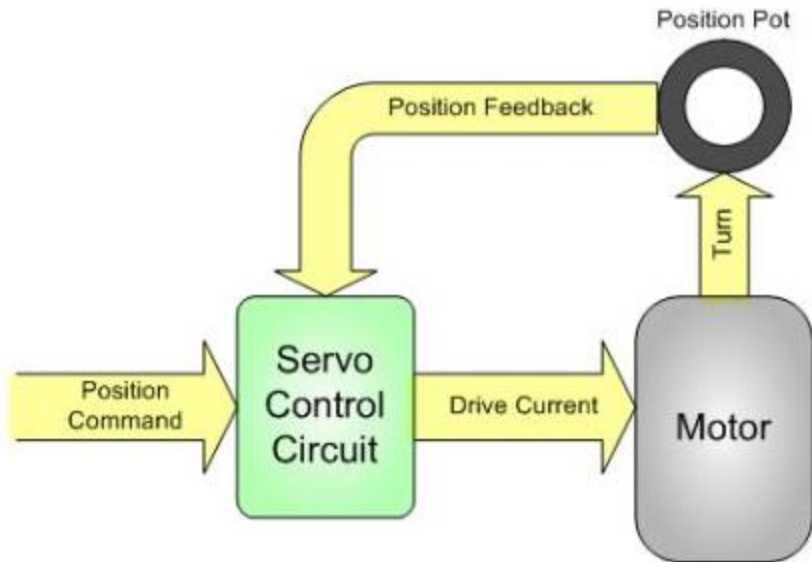

Figure 3: Servo Motor Diagram [3, reprinted with permission from AdaFruit]

Positional rotation motors are able to rotate the shaft of the motor 180 degrees; there are physical components inside of the motor that do not allow the motor shaft to extend past the 180-degree mark. This motor is programmed so that the shaft of the motor will go to a specific position rather than rotating in a specific direction for a period of time. The positional rotation motor is the more popular among the three, often found in remote controlled cars and toys as such.

Continuous rotation motors are very similar to positional rotation motors. These motors can turn infinitely in either the clockwise or counterclockwise directions; they do not have any physical components that cause the motor shaft to stop once it has reached a certain place. These motors are programmed with a direction and speed the motor shaft will rotate. Continuous rotation motors are most commonly found in devices such as radar equipment.

Our design incorporates the use of a positional rotation motor. The servo motor will be used in the pill dispersal aspect of the device and will be powered by the PCB via GPIO pin.

3.3.2 Rechargeable Battery Pack

The Lithium-Ion battery pack is starting to become a common choice when it comes to rechargeable batteries in portable devices. The Lithium-Ion battery pack has a large capacity while being relatively small in size. This battery pack will work well with our device because it is a low cost unit that is very practical in a sense of time efficiency as well as safety for the user. The charging process for the battery has three stages, a slow charge, fast charge, and constant voltage charging stage. Figure 4 below shows the recharging schematic for the Lithium-Ion battery.

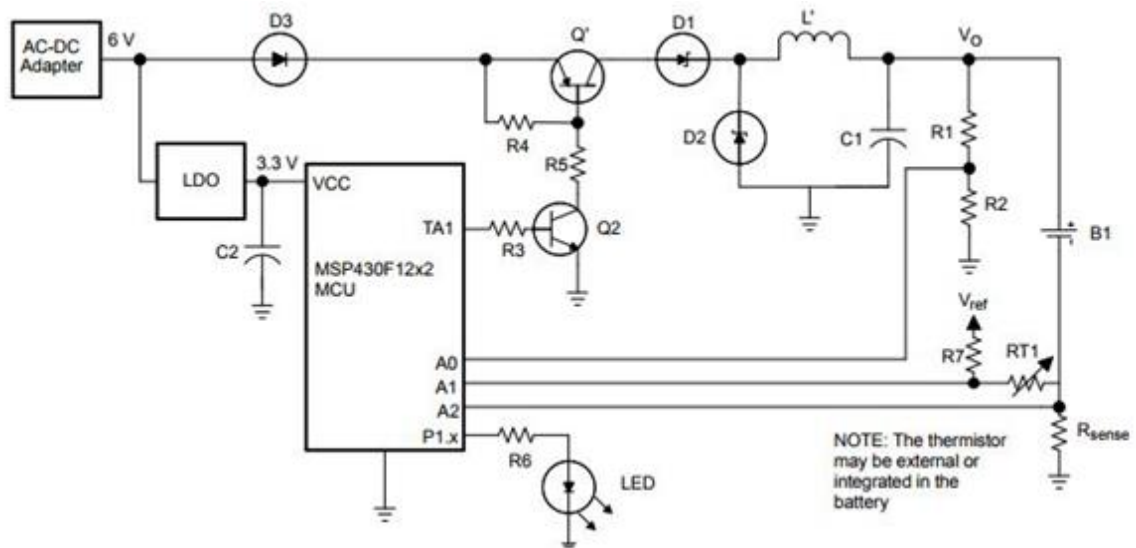

Figure 4: Lithium-ion Recharging Schematic [4, reprinted with permission from TI]

The slow charge stage takes place when the battery is below 2.5V, in this case the battery would be charged with a low current of .1C. This stage is very rarely used since the Lithium-Ion battery pack does not suffer from the “memory effect” which causes the battery to lose capacity if it is not fully discharged before charging. Since the Lithium-Ion battery pack does not need to be completely discharged before using, the user will not have to worry about when to charge the battery, it can be done at any time, and depending on the current voltage of the battery will determine what charging stage the battery will be in once plugged in.

The fast charging stage is the most used recharging stage for the Lithium-Ion battery pack. The fast charging stage will charge the battery pack with a constant current of 1C until the voltage of the battery pack is between 4.1V and 4.2V. In order to ensure that the voltage is in the correct range, the microcontroller’s firmware will constantly check the voltage across R_{sense} and will adjust the duty cycle accordingly. Once the voltage of the battery pack is in the correct range the fast charging stage stops and the constant voltage charging stage takes over.

Once the battery pack enters the constant voltage charging stage the voltage of the battery pack will remain between 4.1V and 4.2V. This stage works very similarly to the fast charging stage in the sense that the firmware will continuously check the voltage and adjust the duty cycle. In this stage, the charging current will fall, the charging process must stop once the charging current is below 0.1C in this stage. In order to combat overcharging a temperature sensor can be used to monitor the heat the battery pack is giving off since most of the electrical energy is converted to thermal energy once the battery pack is fully charged.

3.3.3 LCD Screen

A LCD screen will be implemented into our device in order to show information stored in the microcontroller's memory. A LCD screen uses layers of different materials in order to create a display, these materials include a polarized film followed by a layer of liquid crystals followed by another polarized film that is rotated to be perpendicular to the first polarized film, and these three layers are followed by a reflector layer at the bottom. A LCD screen works in the following way, the two polarized films are rotated 90 degrees from one another in order to polarize the incoming light, the liquid crystals apply a charge through electrodes, and then the reflector layer reflects the light that made it through all of the layers back through all of the layers. The light that is reflected by the reflector layer is what will be displayed on the LCD screen. In order for the LCD screen to work correctly, the screen must be driven by an AC signal; DC signals will usually cause damage to the screen. The screen will connect to the microcontroller through GPIO pins.

3.3.4 Voltage Regulator

Voltage regulators are crucially important because every electrical system is designed to operate within a set range of voltages. A voltage regulator supplies a constant DC source and keeps the voltage of the system at a constant level regardless of how much current is being drawn as well as what the input voltage is. The two main types of voltage regulators are linear voltage regulator and switching voltage regulator. Our device will be using a switching voltage regulator with either a buck converter, also known as step-down, or boost converter, also known as a step-up converter.

3.3.5 Bluetooth Module

A Bluetooth module will be used in order for our device to communicate with the user through devices such as smart phones. Bluetooth takes advantage of radio waves in order to connect to compatible devices. Although the range is often very short, Bluetooth has eliminated the need for wires and cables to connect devices to one another.

Bluetooth typically operates at frequencies between 2402MHz and 2480MHz or 2400MHz and 2483.5MHz which includes two guard bands at the top and bottom of the frequency range, the band at the bottom is 2MHz and the guard at the top is 3.5MHz. In order for Bluetooth devices to communicate properly, Bluetooth uses a technology called frequency-hopping spread spectrum. In frequency-hopping spread spectrum data is transmitted in packets, these packets can be sent through any of the 79 channels that Bluetooth provides; the bandwidth of each channel is 1MHz. With adaptive frequency-hopping, a Bluetooth device can

typically handle 800 channel hops per second. Figure 5 below is a Bluetooth module for an MSP430.

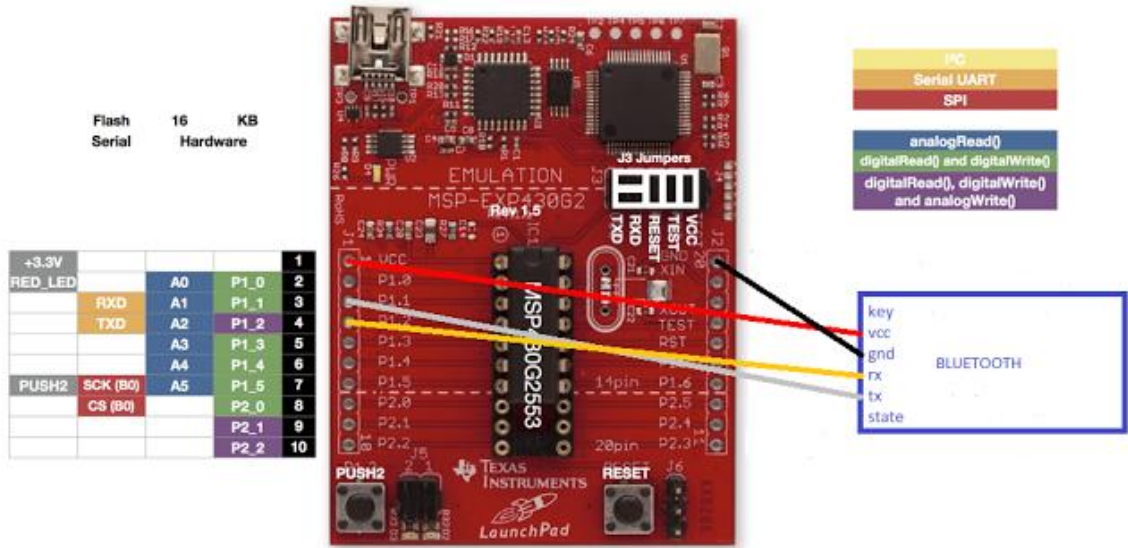

Figure 5: Bluetooth Mapping on an MSP430 Launchpad [5 reprinted with permission from TI]

Bluetooth devices use a master/slave architecture in order to determine what device is sending data and what device is receiving data. A master/slave architecture works in the following way, the devices communicate in a unidirectional way meaning that one device is sending data and the other is only receiving, not sending any data back. The master in this case is the device that is sending the data; the slaves are listening and retrieving data. In Bluetooth, a master device can communicate with up to seven slave devices thanks to the frequency hopping aspect. All of the slave devices share the master device's clock; this clock alternates in 312.5 microsecond intervals. In all cases in communication between the master and the slaves, the master will always begin transmitting on an even interval of the clock, meaning some multiple of 625 microseconds, the slaves are the opposite, meaning they are looking to receive data on odd clock intervals.

In a device such as ours, a small Bluetooth module that is low cost and small in size would be ideal. The module would be connected to the microprocessor by soldering to the GPIO pins. The module will connect to a UART on the microprocessor in order to transmit data. Typically, Bluetooth modules need between 3V and 3.3V, this range of voltages could be met by using a buck converter to step-down the input voltage from the battery pack. In order for best communication between devices, a baud rate of 115200 will be used; this will make the device the most reliable.

3.3.6 Security Sensor

A magnetic contact sensor will be used to track when the device has been opened. This aspect of the device is much like that of a home security system; it uses wireless magnetic contact sensors to determine if the door of the device has been opened due to magnetic fields. When close to each other, the sensors create a magnetic field which tries to pull the two sensors together, when taken apart the field is broken and an alert is sent to the CPU. The magnetic contacts will be using a reed switch to determine if the door is opened or closed. Figure 6 below shows a diagram for the magnetic sensor.

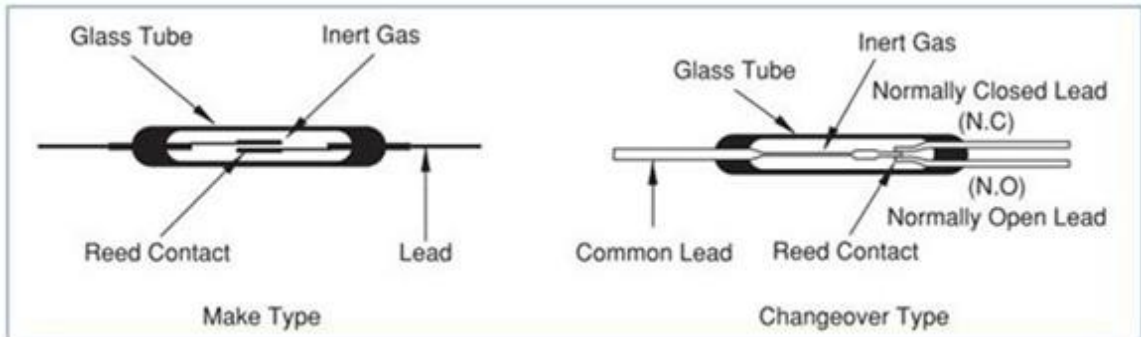

Figure 6: Make-up of a Reed Contact Magnetic Sensor [6 reprinted with permission from EngineersGarage]

A reed switch is composed of two contacts on ferromagnetic metal reeds inside a hermetically sealed glass envelope. The contacts will either rest in the open position or closed position, when a magnetic field is present the contacts will touch if the resting position is open or vice versa. The switch will either be read as always having current going through the contacts, meaning if there was not current going through the contacts the door must be open, or there is never current going through the contacts, meaning that if there was current going through the contacts the door must be open.

3.3.7 Microcontroller

A microcontroller will be the brain of the Medlock. The Medlock requires a very lower power controller. With a requirement of two days of use on battery power alone power consumption becomes an important consideration when choosing all parts. The microcontroller in this case also requires specific IO options as well as timing options. These will be combined with the onboard storage to control access to the device as well as timely disbursement of the pills.

3.3.7.1 Microcontroller Programming

There are three different options for programming the MSP430FR5xxx devices. These options include a bootloader(BSL), joint test action group(JTAG), and an

over the air download (OAD) setup. The BSL is a standard option across MSP430 devices and in the case of the microcontroller chosen in section 3.4.7 this would be performed through a UART connection on the device. A JTAG connection is a more complex programming interface for the MSP430. While JTAG has a debugging interface the BSL and OAD setups do not. JTAG programming can be performed through GPIO pins requiring four total pins. The OAD setup has a slightly larger size on board than the BSL setup and requires a dual image setup to protect the device should issues arise in the communication.

3.4 Component Research and Part Selection

The pill dispensary needs components in order to function so, further on within this section, research and considerations for major parts to achieve both engineering and marketing requirements are clarified. This scope involves comparisons such as microcontrollers, screens, and wireless communication technologies.

3.4.1 Display Technologies

Just how there is the patient's information printed on a sticker of a pill bottle, the device needs to have some feedback to let the person know of the contents inside. Identifying what medication is inside, who it's for, how much is left, how many more refills are left, along with other miscellaneous items such as the date and time are all necessary and the screen needs to be large and bright enough for the anyone to see clearly.

One type of display research were LED displays due to their high visibility, wide usage, and small enough size which could fit inside our dispensary. It would allow the user to see the screen both day and night whether it is in the sunlight or not and has a wide range of colors to choose from. For the sake of the device in the making, dot matrix LED screens were more applicable. However, with smaller screens, the amount of text, and resolution for it would decrease in quality so to counteract this more money would need to compensate the faults. This, of course, is not too desired since other products can produce the same or even better results for less costs. Another fault to it is with more LEDs, more current is drawn to each LED. The amount of current that passes through just one LED is around 30 mA and the amount of power to sustain the matrix as well as the heat produced from the system was ultimately deemed unhealthy for the product in terms of battery life, reducing it when it is meant to stay on without charge for at least 24 hours, and radiated heat to the medication inside. Figure 7 below shows an 8x8 LED dot matrix.

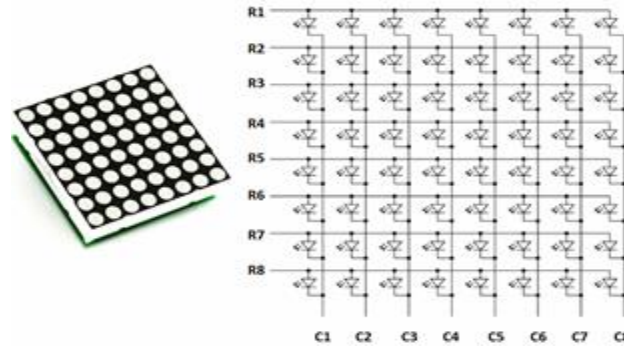

Figure 7: 8x8 LED dot matrix [7 reprinted with permission from Embedded-lab.org]

Another display researched were organic LEDs (OLED) which also have many applications from smart phones to car and radio displays. They can be compact, visible from a wider range of angles, and lightweight as well as flexible for applications that even involve them being attached to clothing. The cost of OLEDs are cheaper than the other options partly due to the manufacturing process being so minimal though a major disadvantage to using these displays is due to their lifespan, performance, and durability. When displaying bright pixels as opposed to darker ones, the power consumed greatly increases compared with other devices but this is because it uses no backlight to keep the screen visible [8, reprinted with permission from Arstechnica]. Since the key point of this display is its organic appeal, water can damage it easily which doesn't bode well when the dispensary is to be used in homes and carried around by the consumer. If suddenly caught in a rain shower or droplets of water splashed on it after washing one's hands, the screen would irreparable. Figure 8 below shows an example of an OLED screen.



Figure 8: OLED Screen [9, reprinted with permission from TrustedReviews]

A type of electroluminescent display (ELD) called thin-film electroluminescent (TFEL) displays were researched because they are used in hospitals, the military, and even for marine use. They are a type of LED where the materials used for the display contains rare earth metals that produce very pure and clear colors depending on how it's configured. They are bright with sharp contrast and a very wide viewing angle, low in power consumption, and highly durable.

However for such a small-scale application that the dispensary is, the cost wouldn't make up for the usefulness another device can output since ELDs are still being researched to lead to more commercial uses which would, in time, make them affordable for general use.

3.4.2 LCD Screens

LCD screens were the most cost effective for our needs, long-lasting, and have a wide selection to choose from since they are used by hobbyists. If the display were to malfunction, perhaps via a dead pixel on the screen, the cost of replacing it would be low enough which makes its use valuable. It's a low-powered device that uses the LED backlight to illuminate the images or text the crystals takes into various colors. The viewing angle isn't as good as other displays, ranging to about 90°. An important note is that due to the low power consumption, there's very little heat emitted which would disrupt the optimal temperature of the medication on the inside of the dispensary.

There were two variations of LCDs that could be used for the device: character or graphic LCD screens. While the graphic display would provide more customization, it would ultimately be more unnecessarily extensive than what is truly needed. This left the option for character LCD screens for further research though, suffice it to say, not many differed from one another. Notable differences, however, did include:

- Backlight Intensity
- Weight
- Polarizer type
- Screen dimension
- Character limit/resolution
- Character/background color

Table 3 below describes the subtle differences between each of the character displays.

			
Company Name	CrystalFontz	East Rising	Winstar
Part Name	CFAH1604B-TMI-ET	ERM1604SYG-1	WH1604A
Character x Lines	16x4	16x4	16x4

Polarizer	Transmissive	Transmissive	Transmissive
Backlight	White	Yellow-Green	Yellow-Green
Controller	Sitronix ST7066U	HD44780	RW1063
Screen Dimensions	60 x 32.6 mm	61.8 x 25.2 mm	62 x 26 mm

Table 3: LCD Screen Table [Permission Pending]

These character LCDs were considered due to their simplicity and are available in either 3V or 5V input voltages so depending on what other components are chosen, these screens can be compatible with them. Choosing among these was a matter of cost, size, and overall visibility of the characters. Having a backlight allows the user to view the screen easily from indoors and nighttime while a transmissive polarization means the screen can be seen when exposed to sunlight and well-lit areas. The LCD controller that the LCD screen itself is compatible with provides the programmer with a standard set of characters to use. Again, the datasheets don't vary too much from each other but the purpose of the controller is to use the preset character and symbol list to display whatever string is needed. Of the three listed, the ERM1604SYG-1 seemed like that best choice to work with due to the visibility compared to the other two.

3.4.3 Speakers

To alert the user that their medication is ready to be taken, a speaker/buzzer would help notify them that their pill is ready. The use of more than one buzzer would allow for differing levels of alarm however they would need to be small enough to fit inside the device which would ideally be held and carried around by the user. They would be controlled via the microcontroller to lightly sound when it was time to take the medication, then to sound louder if the medication has not been taken within a certain amount of time, and also to sound quietly when it is due for a refill.

3.4.3.1 Surface Transducer

Transducers essentially convert electrical signals into mechanical signals or other electrical signals such as energy, heat, light, etc. and are extensively used for many more applications than with sound production. They can come in varying sizes which can fit on a PCB though it can be bulkier than a piezoelectric buzzer. The specific type being researched is the surface transducer which uses a magnet wrapped in a voice coil housed in a metal, cylindrical device with a flexible material attached to only one its flat sides. Placing this on a surface presents the effects of a speaker which can be used for beeps, chimes, tunes, etc. to be played when the device needs to catch the user's attention. This

approach, however, begs the question of which surface to use and could jeopardize the real estate inside the dispensary if the surface required needed to be larger than desired.

3.4.3.2 PCB-Mounted Speaker

These run-of-the-mill speakers can produce sounds and noise quite decently to around the same decibels as the piezoelectric buzzer and surface transducer [10, reprinted with permission from feonic]. Their frequency range goes from 320 Hz to 7.5 kHz and they are compact enough to be placed on a PCB, but as the speaker reaches its resonant frequency, the chance for it to overexert and disrupt is very likely. Due to this factor, this type of audio system won't be considered in the device's design.

3.4.3.3 Piezoelectric Buzzer

The piezoelectric technology was considered because they are small enough to fit on a PCB, the sensitivity of these devices is very high while their cost remains affordable, and customizing the noise or tone can be done with a square wave output from a PWM i.e. creating a continuous tone as opposed to chirping. Depending on the amount of voltage applied, the pitch can be altered to a frequency range of 1 kHz to around 4.7 kHz allowing for a decent spectrum of sound for alerting with a decibel rating from 70 dB to 100 dB. Due to its high sensitivity, the electrical noise as well as power consumption is low and makes it ideal for the application it's being used for. There are more expensive versions that can create multiple tones on one device but because the cheaper version is so small already, using more than one on a PCB shouldn't be an issue. For these reasons, the piezoelectric technology was chosen and the device PS1240P02BT will be used.

3.4.4 Wireless Communication

While the pill dispensary will be able to communicate to the user needed information via the display screen, audio cues, and an LED system, it is understandable that these may not be enough to alert some who are more forgetful than others. Because these would be brand new devices to be carried around both inside and outside of the home, forgetting where it was last placed may be more common than not. With this in mind, having a form of wireless communication sending notifications of when their medication is due or that they are too far from their dispensary via the consumer's mobile phone would be ideal.

The choice of wireless instead of the wired counterpart is not only out of convenience but out of practical necessity. The convenience factor comes in when considering carrying said wires around connecting the phone to the device then having to handle both in public but practically speaking, the maintenance of

the wires, their length, upgradeability, and damages that can occur would not be as cost effective for neither the manufacturer nor the consumer.

There are many options to choose from designing a device that communicates to an already existing wireless device. The technologies involved would be chosen for practicality and capability. The ones considered were Wi-Fi, infrared (IR), radio frequency (RF), and Bluetooth.

3.4.4.1 Wi-Fi

Wi-Fi technology is now the most used, widespread technology when it comes to wireless communication. It runs through a wireless local access network (WLAN) labeled the IEEE 802.11 standard to homogenize the use of this type of communication ranging from frequencies of 2.4 GHz to 5 GHz for commercial use separated by different channels using filtering systems. From homes to offices to restaurants, Wi-Fi is connected to them via a digital subscriber line to a router to broadcast signals that link with the Internet [11, reprinted with permission from Webopedia].

This connection can range locally up to 300 feet or over 20 miles depending on what type of protocol is including with the 802.11 standard. With this system in place, the device would be able to connect to the user's mobile phone and send notifications from any distance as long as it had a steady connection to the WLAN however this in itself poses a problem. The device shouldn't be so far from the user in the event that their medication is due before the time they can get back to it. Also, connecting to the Wi-Fi can also pose a number of security threats which leaves the system open to attacks and creates the issue of confidentiality in terms of this medical device.

3.4.4.2 Infrared

IR is a means to communicate to other devices by an unobstructed, "visual" connection. It falls between visible light and microwaves on the electromagnetic spectrum meaning that its waves are long and slow moving while its frequency runs from 300 GHz to 430 THz when it comes to naturally occurring infrared waves. In terms of device communication, the module would have to be in the line of sight with the mobile phone in order for it to receive any information which means that both devices would have to be out in the open for alerts or notifications. Once they're seeing each other, the one receiving signals would be able to recognize the transmitting module due to its rapidly switching signals which would be unlike the natural infrared signals. While this piece of technology wouldn't be able to interfere with other devices when it is covered, just that in mind makes one of the primary purposes of the design completely ineffective.

3.4.4.3 Radio Frequency

RF is another medium that utilizes frequency as a means to communicate to other devices but can also be used in practices of medicine and the military. In relation to the dispensary, it would not have to be optically presented to the mobile phone and can penetrate objects to transmit or receive radio signals wirelessly. Relevant applications of RF include remote controlling, data transmissions, and home automated apparatuses such as garage door openers and light control systems.

Incorporating RF technology in the dispensary means adding an RF module which are around 430 MHz. The performance of these modules depends on the distance from where it's attempting to communicate with. The farther apart they are, the more power it's going to consume meaning a shortened battery life but also with a high-power output could mean the interference with other device would could ultimately cause the system to malfunction.

3.4.4.4 Bluetooth

Bluetooth, governed by the Bluetooth Special Interest Group, is used for wireless communications over relatively short distances from around 5 m to 100 m with the use of ultra-high frequency (UHF) and it is all at the benefit of low power and cost. It runs on a personal access network (PAN) and because most devices are already compatible to use Bluetooth technology, configuring a module with it to interact with a mobile phone would be transparent.

The connection is the module is surface mounted and uses technology called frequency-hopping spread spectrum (FHSS) to transmit and receive data [12, reprinted with permission from Wikipedia]. Its packet-based protocol synchronizes data using a master/slave architecture which allows for simple communication. FHSS allows for a robust communication system that guards against interference due to the master choosing the sequence of frequencies between 79 different channels of 1 MHz used to send and receive data. This means only the transmitter and receiver knows and is authorized to use those channels. With direct communication from device to device and updated security protection, there is no issue with it interfering with other devices or connecting to network either. A disadvantage to this technology is how the data transfer speed is slower compared to RF. Regardless, that concern isn't an issue in the bigger scope of the project especially with how inexpensive Bluetooth is compared to other options.

Considering the availability of Bluetooth in already existing devices, two modules were researched for compatibility as well as upgradeability for the dispensary: the RN-42 and HC-05 Bluetooth module.

3.4.4.4.1 HC-05 Bluetooth Module

This module comes with a PCB antenna which is necessary for high frequency applications and supports UART as well as USB hardware. It is of version 2.0, has an enhanced data rate (EDR), and is compatible with PCs and Android systems. It can run as either a master or slave as default with an SPP module. Table 4 below describes more product specifications [13, reprinted with permission from Wikispaces].

Parameters	Values
Version	2.0+EDR
Power Supply	3.3 V
Sensitivity	-80 dBm
PIO	11
Baud Rate	9600 to 460K

Table 4: HC-05 Module Specifications

3.4.4.4.2 RN-42 Bluetooth Module

This module can come with or without a PCB antenna, depending on the model, in case the application calls for an external antenna to use, making this module versatile and less redundant. Features include UART with SPP or HCI and USB with only HCI hardware interfaces. For security, it comes with a 128-bit encryption and error correction for packet delivery. It can connect to PCs, Android, and iPhone devices with HCI data rates of 1.5 Mbps sustained and 3 Mbps in burst as well as SPP data rates up to 300 Kbps for the master controller and 240 Kbps for the slave [14, reprinted with permission from Microchip.com]. There's also the option of using its GPIO though only a select amount would be considered useful and should only be used if needed. Table 4 below describes more of the product's specifications.

Parameters	Values
Version	2.1+EDR
Power Supply	3.3 V
Sensitivity	-80 dBm
Temperature Range	-40 C to 85 C

PIO	11
Baud Rate	9600 to 460K

Table 5: RN-42 Module Specifications

Figure 9 below shows two examples of Bluetooth modules.

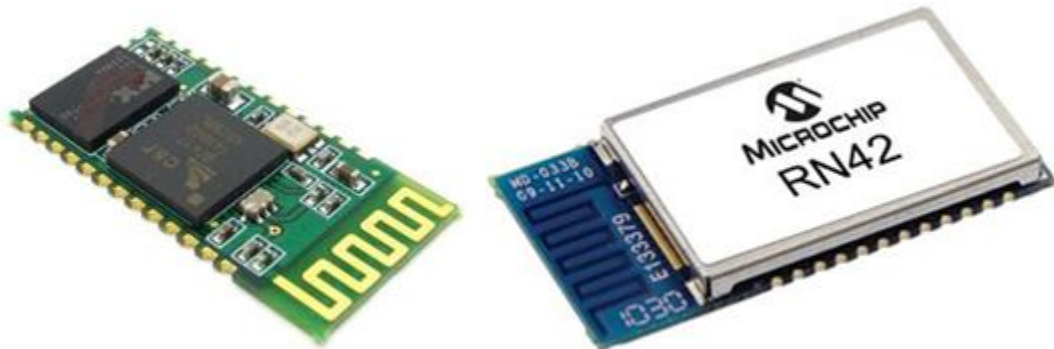

Figure 9: HC-05 Bluetooth Module (left), RN42 Bluetooth Module (right)
[reprinted with permission from Microchip.com]

3.4.4.4.3 CC2650

Further research into both of these modules found that while they are compatible with android and PC devices, it would be extremely difficult, if possible at all, to have it work with iOS devices. The compromise of just implementing one over the other would completely hinder the device and would not make it as universal a product since it will leave out millions of customers because of one missing key feature. Because the use of Bluetooth is so useful and relatively simple for people to operate, this technology is still considered and a solution was found. Instead of using a dedicated module for wireless communication, the Bluetooth feature on the CC2650 microcontroller can be utilized not only to save space in the device but also for its capability to operate on both Android and iOS machines.

3.4.5 Pill Dispensing Technology

Ideally, the pill dispensary is handheld and portable meaning that the mechanical component must fulfill this requirement as well. Servomotors, luckily, serve as a widely available and simple mechanism to rotate and move objects. They come in numerous sizes, require only basic installation, and cut some of the work out of the microprocessor when it comes to commanding the rotations to specified positions.

For the sake of this dispensary, pills are to be stacked in two to three columns where the opening to dispense it would be at the bottom. Gravity aids in pushing

the pills down the column however in the case where the device would deviate from its upright position, a spring coiled at the top of the columns would assist in keeping the pills in place so the device wouldn't jam and/or be unable to administer the medication. This structure is akin to an upside-down magazine of a gun which makes this form of dispersion practiced, however the pills will be dispensed in a much less violent and slower manner. Figure 10 below shows a sketch of what the proposed pill dispensing system.

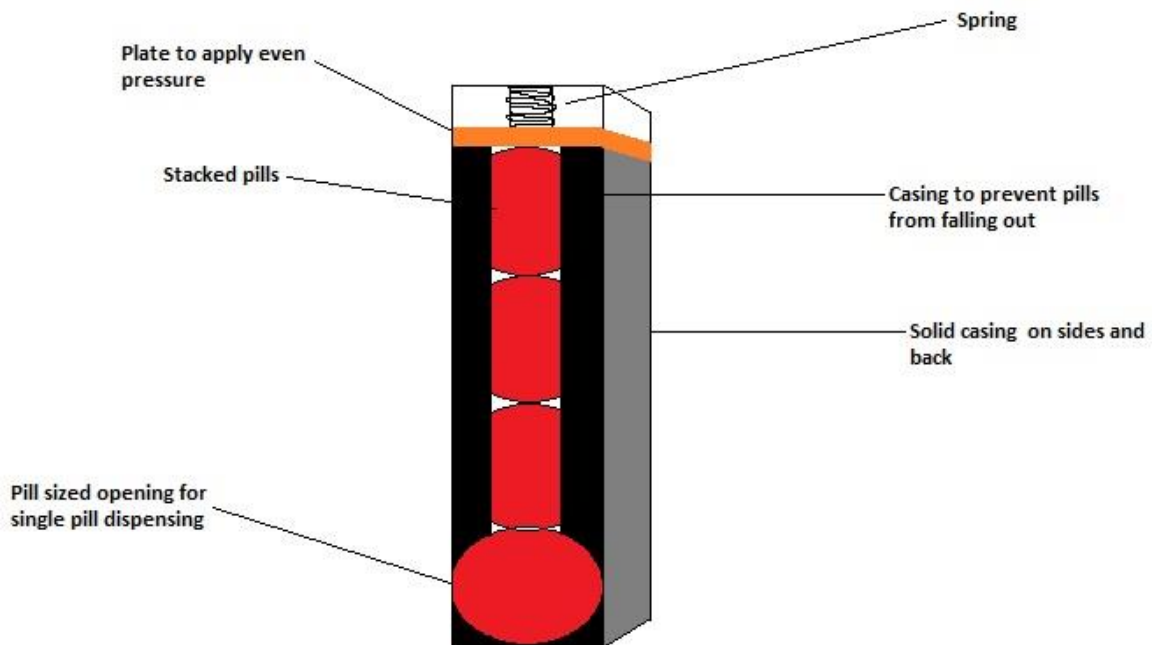

Figure 10: Pill Dispenser

The microcontroller would control when to send a signal to the PWM to activate the servo to rotate the base of a small rod, pushing it forward along a track which slides the pill forward into the dispensary tray then pulls it out of the track to reset its position. About two or three servos need to be implemented in order for the device to store up to 60 pills and still fit within the dimensions desired.

There are many types of servomotors in the market but only DC, positional servos have been considered. Another concern looked at was the weight of the servo which lead into research on lightweight builds such as the 9-gram variety. The HXT900 servo provides the above specifications and it is well within our budget, shown below in the Figure 11.



Figure 11: 9-Gram Servomotor [15, reprinted with permission from Hobbyking]

3.4.6 Power Supply

The purpose of this device, aside from dispensing in a timely manner and protecting the consumer from abusing the medication within, is to be carried around inside and outside of the house all while the power is on. Considering this, having the device always plugged into an outlet to keep it on isn't practical in the least. Another major concern to keep in mind was heat management. Medications come with their own specifications on how to administer them as well as instructions on how to store them, temperature being a large factor in keeping the proper effects of said medicine valid. A portable energy source is required for this pill dispensary.

Specifically, researching rechargeable energy sources is ideal since it wouldn't be practical at all to only be able to use the dispensary after one complete charge of the source then have it immediately inoperable. One of the goals for Medlock is for the device to be powered for at least 48 hours via a power source then recharged using an AC/DC adapter to plug into the power source. This leads to researching various power sources as well as adapters for those sources.

Solar energy was briefly researched as a means to power the device at hand however, the method concluded to not be as effective or efficient for the power required. For almost 2 V, a 3" x 0.5" piece of solar strip would be needed meaning that to power an estimated 9 V device, it would be proportional to the area of the strip and also the amount of time it would be exposed to the sun for it to be charge up. Though it would only dissipate its charge quickly making the effort fruitless.

3.4.6.1 Batteries

Batteries seem to be the most resourceful in terms of a portable energy source for hours of a day. There are many types of rechargeable batteries to choose from but the most common to choose from are lead acid gel, lithium-ion, nickel-cadmium, and nickel-metal hydride.

Lead acid gel batteries are used in equipment such as scooters, boats, RVs as well as portable devices and come in the shape of sealed rectangular casings. It was quickly found out that this source was more sensitive to negative effects for overcharge and is more sensitive which reduces performance and increases malfunctions.

Nickel-cadmium (NiCd) batteries as the name might imply, is made up of nickel oxide hydroxide with cadmium electrodes. A trend with nickel-based batteries are that they are charged with a constant current through the voltage can freely rise. With this information, knowing the state of a fully charged nickel-based battery happens when a voltage drop occurs. Advantages to using this type is its long shelf life (though it still needs charging after some time due to self-discharge), high charging cycle count, robust in terms of durability. Though, compared to other batteries, the energy stored is low which means it requires more cells for a high nominal voltage output. It's also very toxic to handle so after its life it needs to be disposed of properly.

Nickel-metal hydride (NiMH) is used in major battery companies such as Energizer, Duracell, and Rayovac partly because it is low in cost for manufacturing. It provides a durable and less toxic alternative to NiCd with a higher energy density however its charging algorithm is complicated and it discharges at the same rate as NiCd.

Lithium-ion (Li-ion) is the most popular out of the three listed. It's lighter, has the greatest electrochemical potential, and a higher energy density. The cathode is made up of the lithium metal while, to stabilize the effects of self-discharge, the material graphite is used as the anode. Not only is the form of carbon abundant, it benefits the system more than coke which was used before as the anode by Sony. The usage of said coke has declined mostly since 1997 however. Comparatively out of the three choices, its self-discharge is the lowest meaning it doesn't need recharging before use not nearly as often, the charging algorithm is simple so it takes less time to charge, and it's efficient. One downside to Li-ion is that it would call for a protection circuit to prevent damages if the battery is stressed which leaks thermal energy into it. Though regardless of this minor addition, Li-ion batteries are the better option out of the three looked into. Table 6 below is a comparison of the three possible batteries considered.

Battery Type	NiCd	NiMH	Li-ion
Charge/Discharge rating	70%-90%	66%-92%	80%-90%
Discharge rating	10-15% in 1st 24 hours, then 10-	10-15% in 1st 24 hours, then 10-	5% in 1st 24 hours, then 1-2% per month

	15% per month	15% per month	
Charging Temperature Range	0 C to 45 C 32 F to 113 F	0 C to 45 C 32 F to 113 F	0 C to 45 C 32 F to 113 F
Discharging Temperature Range	-20 C to 65 C -4 F to 149 F	-20 C to 65 C -4 F to 149 F	-20 C to 60 C -4 F to 140 F
Energy Density	50-150 Wh/L	140-300 Wh/L	250-693 Wh/L
Nominal Voltage	1.2 V	1.2 V	~3.6 V
Recharging Cycles	2000	180-2000	400-1200

Table 6: Battery Comparisons [16, reprinted with permission from BatteryUniversity]

The battery chosen is the AT: Tenergy Li-Ion 18650 for its longer battery life, nominal voltage of 3.7 V, and the charge/discharging rates. Li-ion batteries are becoming more and more commonplace as well so most devices being created are running off of Li-ion battery packs for a great number of products and components. Other variations of Li-ion include it with cobalt oxide, manganese oxide, and a polymer but for simplicity, the standard type of Li-ion is used.

3.4.6.2 Charging Mechanisms

Because one of the chosen required specifications of Medlock is to be portable, meaning it would have to be running off of an internal reserve of energy, it needs to have the capability of being recharged. As mentioned very briefly in section 3.4.6, this machine needs to run consistently on more than just one cycle of the power source. To achieve this, a charging system of some sort need to be developed that is able to ideally quickly charge the device to have it stay charged for at least 48 hours without connection to the main power source of the charger.

When looking into how exactly the internal source will be charged, a number of options were available. From simple chargers and trickle chargers to smart chargers and USB power delivery (PD) chargers [17, reprinted with permission from Northeast Battery], each of them of their own benefits that favorably work in conjunction with the dispensary. In the United States, normal household power outlets provide 120 V at 60 Hz so a charger able to transform this comparably high voltage down to a suitable voltage for the dispenser is necessary. Features such as charge time, charge speed, whether it charges via constant voltage or constant current, and connection from the device to the main power supply were reviewed when choosing which one would be the most viable to use.

3.4.6.2.1 Simple Chargers

As the name would imply, these chargers are relatively simple compared to other charging mechanisms. This type supplies DC power to the battery at a constant, slow rate and does not stop even when the device is fully charged. This could lead to over-charging and possibly damaging parts if left plugged in. The circuitry involved is cheaply designed which makes it affordable for basic usage, however, because this is a device set for making reminders for taking medication and not to attend to unplugging the charger so it won't malfunction, this product was ruled out.

3.4.6.2.2 Trickle Chargers

Trickle chargers are a type of charger in which you don't need to worry about overcharging due to their need to charge for a long time to be completely charged. The slowness is usually at the rate of the battery's discharge which, for a Li-ion battery, is about 2% of its life. The disadvantage with this type of charging is, of course, the rate at which it charges. Since Medlock is designed to be portable, it is inherently designed to be plugged out from its charger for extended periods of time. However, this the feature of slow charging isn't as bad as it might seem. Keeping heat management in mind, the slow charge rate means little thermal energy is produced thus increasing the longevity of the device.

3.4.6.2.3 Smart Chargers

Smart chargers charge in accordance to the battery's current state. At low energy, fast-charging occurs until it is near full capacity (about 80%) where it switches to the trickle charging method mentioned in the section above. This means that the charger contains some circuitry enabling it to read and record information about the battery so it can charge as efficiently as possible, avoiding overcharge and damaging what it's connected to. Unfortunately, this is more expensive and complex than it's worth in the scope of this device.

3.4.6.2.4 USB Chargers

USB chargers are actually power adapters providing a constant stream of 5 V with varying levels of current depending on what version it is. USB 1.0 and 2.0, for example, has a current of 500 mA while USB 3.0 has a current of 900 mA which makes the charging on a 3.0 device faster [18, reprinted with permission from BatteryUniversity], especially if the device in the process of being charged is also being used. Even at these levels, the charge may be slow but, more specifically for an Li-ion battery, this should not matter too much because the life of it lasts longer when it isn't fully charged. This is due to a characteristic it has in

which it becomes stressed and discharges at a faster rate when at high voltage [19, reprinted with permission from BatteryUniversity]].

The most recent type of connector called type-C is standard to the USB 3.1 where it doesn't matter which way you plug it into your device, it would work regardless. This type can provide higher levels of current, such as 1.5 A at the same 5 V stream which gives way to faster charging though the pill dispensary may not need such a feature.

Because USB technology is still growing and improving, it seems to be in the best interest to use it, if only for the sake of learning more about it since its application is used from desktop computers, to laptops, cell phones, and many more pieces of technology to either stream data or charge appliances. There are a few types to choose from with their own benefits which will be shown in the Tables 7 and 8 below.

USB Types	Standard A	Standard B	Type-C
Pins	4	4	24
Standard Dimensions (mm)	Rectangular 12 x 4.5	Cube 8.45 x 7.26	Rectangular 8.25 x 2.4
Reversible?	No	No	Yes

Table 7: USB Type Comparisons

USB Versions	2.0	3.0	3.1
Max Voltage (V)	5	5	20
Max Current (A)	0.5	0.9	3
Backward Compatible?	Yes	Yes	Yes

Table 8: USB Version Comparisons

Standard A and B can shrink down to micro ports now for a smaller and sleeker design to fit in the style of cell phone chargers but the type-C was already made in that fashion. There is also the option for a larger current draw for faster charging with the USB PD offering up to a maximum of 20 V and 5 A. Now as

mentioned above, fast charging isn't always the better option as it can lead to quickly heating up the battery in the device with the intense amount of current coming in. However, the amount of this current is dependent on what the device requires meaning that there is no chance that any damages can be caused. Nevertheless, this is still taken with a grain of salt and a battery recharge protection circuit will still be in place in the case of a malfunction somewhere.

The versatility and ease of use of the type-C USB chargers is becoming more commonplace than the standard A and B versions in the past. The latest version is also backward compatible, making it the fitting choice. Specifically for the type-C, because it has 20 more pins than the other types, it's level of speed and data transfer excels where the others do not. This allows for just one port to be attached to the dispensary instead of one dedicated for power charging and another dedicated for data transfer. The choice in specific part unit to use is the Amphenol FCI 10137061-00021LF which is a through hole, USB 3.1 type-C female connector.

3.4.7 Security Sensors

One of the main purposes of Medlock is to create a device where tampering with to get it open penalizes the user, resulting in a discontinuation of refills from their pharmacist until further notice from their prescribing doctor to detour from drug abuse and addiction. In order to find out if the device has been opened for unauthorized use, a sensor will be placed inside the dispensary, for both discretion and so there isn't a chance for someone to pry it off from the outside then reconstruct it back on. Once opened, a signal would be sent to the microcontroller recording the date and time the device was opened for the pharmacist to see. This would be shown on the display screen when the pharmacist opens the dispensary to refill it automatically or there will be a push button inside the device for them to check the amount of times it has been opened. For this to work, a sensory system needs to be chosen, prompting the discussion below.

3.4.7.1 Infrared Sensor

Infrared waves are useful in many applications, a few being motion detection, heat detection, and signal responses, because all substances, living and nonliving, have some amount of thermal energy to them. This thermal energy is what makes these objects become sources of infrared radiation. Since this radiation can't be seen with the naked human eye, temperature readings are usually used to show the levels of heat dissipating from an object, usually depicted using the visual spectrum where red colors are hot objects and deep blue colors are cold ones.

With this information, a device that sends a specified wavelength of infrared waves as a source, or emitter, to another device to capture those signals, such

as a photodiode, can be used. If there is a change in the signal captured i.e. if the connection between the two devices were disrupted, the microcontroller would get alerted and the event would be recorded. Infrared technology is reasonably affordable, typically under \$10, and can be incorporated into the circuit design for the device, but depending on the sensitivity wanted, the price could rise. Due to such close proximities within the casing of the device, the sensitivity level may not have to be too high. The base voltage rating for a simple IR sensor is 3.3 V which would give a better power rating than its voltage that produces higher sensitivity at 5 V.

One of two concerns for using this is the possibility of having the incredibly high frequencies distort signals with the rest of the circuitry since it is a form of electromagnetic interference. This could lead to mixed, inaccurate readings. To alleviate this concern, the circuitry for this design should be orientated close to the power supply where other high frequency configurations are to reduce to the amount of noise muddling signals. The other concern is unintentionally sending the IR signals to other components. For this issue, the head of the receiving and transmitting ends of the sensor need to be close together and aligned properly so there is a continuous, steady stream from IR LED to photodiode.

3.4.7.2 Magnetic Sensor

Magnetic sensors come in a few forms but the types using the Hall Effect and reeds were investigated. Hall Effect magnetic sensors use the positioning of the magnet to manipulate voltages. If the distance between them increased, such as the opening of the dispensary, the voltage would decrease and a signal would be sent to the MCU and recorded.

Reed switch magnetic sensors are commonly used as simple proximity sensors and tamperproof technology. Depending on the magnetic field passing through them dictate whether the reeds are touching or not. Though regardless of what position they start in, once there is a change in the magnetic field strong enough to move the reeds, a signal would be sent to the MCU. There is a possibility that this method can become ineffective if one were to present a strong enough magnetic field to manipulate the device so it may not be completely foolproof but under normal conditions, it's a sufficient and very inexpensive device. As with the infrared sensor, the price does increase with the sensitivity rating though the pricing is about the same when compared to each other.

3.4.8 Microcontroller Selection

With the previous experience of working with the MSP430 series they were chosen as an initial product group. With a quick scan of the Texas Instruments website it became obvious the MSP430G2x/i2x series are not viable options. The Medlock requires two UART ports and while all other MSP430 ultra low power groups support a two UART option, the MSP430G2x/i2x does not. All MSP430

microcontrollers that support two UARTs also support a minimum of two 16-bit timers. While the UARTs will be used to control the screen that outputs patient information on the medication and time the timers will be used to keep track of time since medication has been taken. A clear majority of the remaining microprocessors contain the requested 512 b RAM and 8 kb non-volatile memory. Having this much memory available should allow for instructions on the medication as well as basic patient information to be stored. The memory will also contain the last time a pill was taken and a record of every time the device was opened. The final specific number requested was 24 GPIO pins and even with this consideration there are still over 100 MSP430 microcontrollers that met all criteria. A VQFN package is smaller than the other available packages making it an ideal choice for a device designed to be carried around. Figure 12 below is a block diagram of the MSP430FR5858, which was the original choice for a microcontroller.

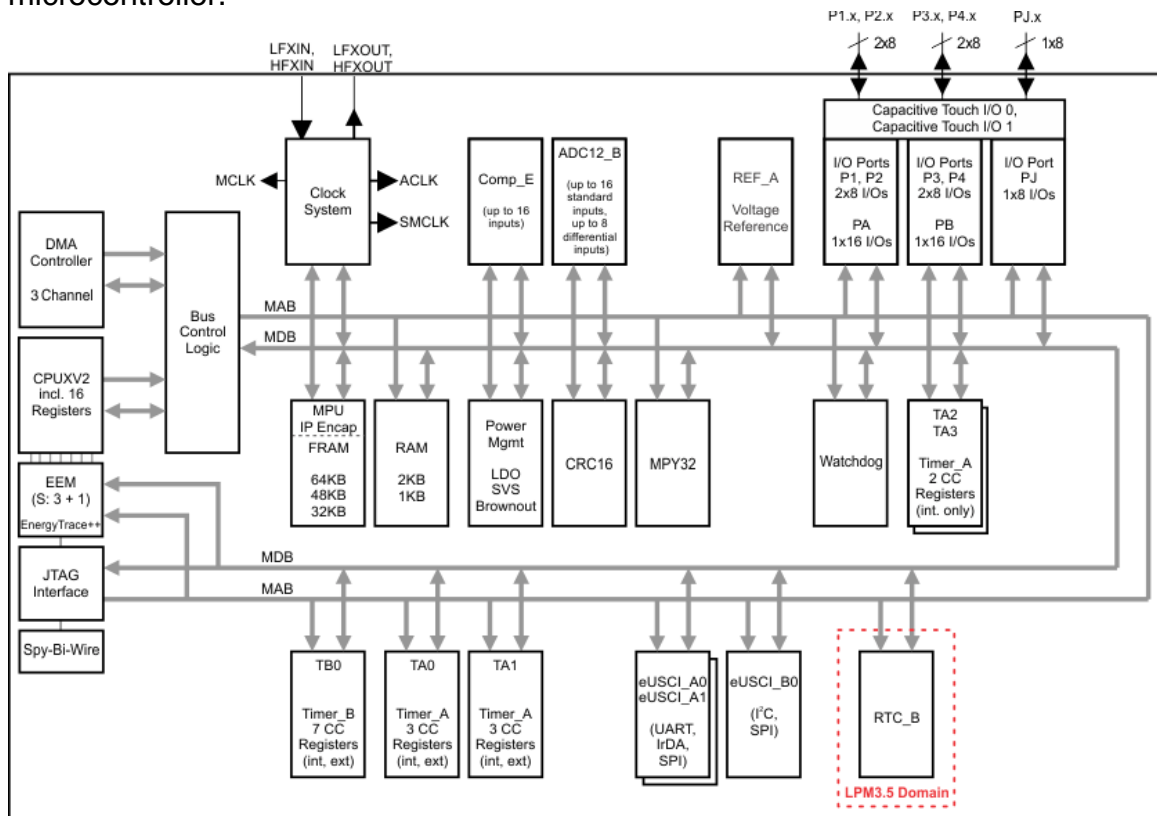

Copyright © 2016, Texas Instruments Incorporated

Figure 12: Functional Block Diagram [20, reprinted with permission from TI]

With these considerations, out of the way power consumption and price can be considered. The MSP430FRxx FRAM contains controllers operating at much lower power consumption than the other groups. With similar minimum and maximum voltage operation ranges on the MSP430 devices the current was inspected. With a minimum active power of 91.667 uA/MHz a max of 105 uA/MHz 56 controllers still meet all specifications. Dropping the maximum standby power to 1 uA in the LPM3 mode the total parts remained at 51

controllers. While steadily lowering the price by \$1 per iteration a group of three processors remain each costing \$1.57/1ku.

The three remaining controllers include the MSP430FR5847, MSP430FR5857, and the MSP430FR5858. All things being equal except the MSP430FR5858 contains an additional 16 kb of nonvolatile memory and an additional 1kb of RAM. While this memory isn't useful for the original design it will leave room for expansion in potential future iterations of the design. The table showing these comparisons can be viewed for quick selection. While the MSP430FR5858 was the original choice based on these considerations additional concerns became available when going through a layout of the hardware.

The MCU chosen was a Texas Instruments(TI) device and other pieces chosen followed suit to enhance the likelihood of compatibility during prototyping and testing. While inspecting the Bluetooth module however it became known that the available modules were not compatible with the IOS operating system. Considering the quantity of the market that uses IOS devices it was considered impractical to neglect coverage of so many devices. A call to TI gave the suggested option for coverage of both IOS and Android. Unfortunately, this required an entirely different MCU.

The CC2650 is a wireless supported MCU and provides the needed support for both IOS and Android. Consideration for Microsoft or any other potential operating systems for Bluetooth devices was not provided. Multiple UART inputs are still required and unfortunately the CC2650 only has a single input and a single output that supports the UART protocol. The solution to this problem however is much more efficient than other solutions for the Bluetooth issue. Table 9 below compares the different microcontrollers that were considered.

Controller	MSP430FR5847	MSP430FR5857	MSP430FR5858	CC2650
UART	2	2	2	1
Non-Volatile Memory (kb)	32	32	48	128
RAM (kb)	1	1	2	8
GPIO Pins	33	33	33	15

Timers – 16-bit	5	5	5	8
Min VCC (V)	1.8	1.8	1.8	1.8
Max VCC (V)	3.6	3.6	3.6	3.8
Active Power (µA/MHz)	101.25	101.25	101.25	61
Standby Power (LPM3-µA)	0.5	0.5	0.5	1
Size	36 mm ² : 6 x 6	36 mm ² : 6 x 6	36 mm ² : 6 x 6	25 mm ² : 5 x 5
Cost (US \$)	1.57 / 1ku	1.57 / 1ku	1.57 / 1ku	2.52 / 1ku

Table 9: Microcontroller Comparison [Permission Pending]

3.4.9 LED Choice

Only two LEDs will be required per device. To keep a simple interface making the device appear clean and appealing to a wide range of audiences, colors will be different for the two different applications. A white LED with a high degree of viewing angle would be optimal to be viewed from all angles when inspecting the device. The LEDs will indicate that a pill is ready to be taken and will dispense when the user presses the release button. With a cost of \$0.49 and discounts for bulk purchase this easily falls within the budget of the Medlock and can be a nonintrusive indicator that medication is ready. An alert for battery low is also necessary and will be a red LED. This will turn on at 10% battery remaining. This will be an indication that the user has just less than 5 hours to plug in their Medlock before it powers down. Figure 13 below shows an example of the LED's that will be used within this project.

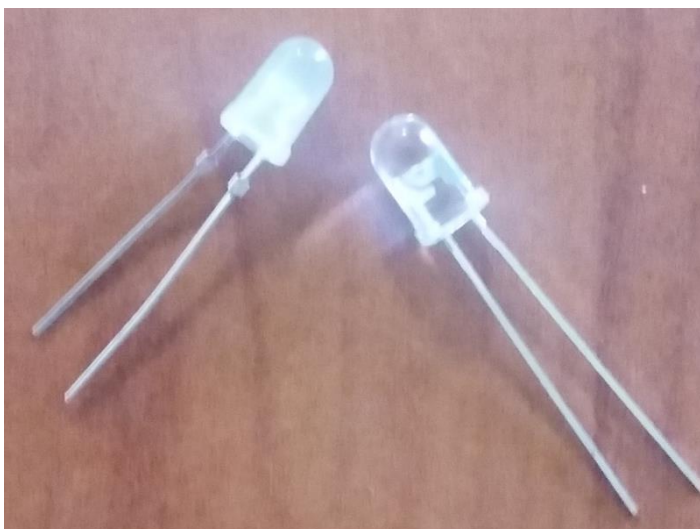

Figure 13: 5mm LED

3.4.10 Programming Interface

There are two possible options as to what can be used as a programming interface. The first option for the ARM Cortex M3 is using a level shifter to move the computers supplied RS232 signal down to a TTL UART signal that is readable by the CC2650. The signal making it to the CC2650 must be a TTL UART signal regardless of its origins. It however is not common for computers in the modern age to come equipped with an available port to transmit a RS232 signal. However, it is extremely common for computers to have an available USB port. For those with a USB port the second option would be far more practical.

To program the CC2650 a direct connection from a computer's USB port is not sufficient. A UART connection must be used to program the device. This causes an additional problem because the only UART port on the CC2650 is already taken. A MUX must be used to decide which of the two UART signals should be input the MCU at a given moment. The programming of the Medlock should only occur once, but may require updating at some point. This means a dedicated connection piece should be available on the board to make a connection. There are two different possible XDS100 cables that support the ARM Cortex M3.

The original choice was an XDS100-V2 cable that provides support for the Cortex M3 and can be gotten with a 20 or 14 pin connection. This is useful for emulating the COM port from a USB connection and would function to program the Medlock. The V2 is an older model of the cable however and not as fast as the V3 version. The V1 is a legacy model and doesn't even have support for the CC2650 so there was essentially no consideration of the V1. The V3 has the updated IEEE 1149.7 standard, which would have the Medlock being programmed at the current standard. [21, reprinted with permission from TI]

3.4.11 UART MUX

A mux is necessary to be able to switch between signals being sent to a single pin. Thankfully only two UART signals that will never be necessary at the same time are going to be received by the MCU. Both the XDS100 and the infrared sensor will communicate through the UART port. While programming the Medlock there will be no reason to keep track of the door and whether it is open or not. There are plenty of different options to choose from with variations in the number of inputs to be switched between, but the Medlock only requires a 2:1 device. This means a single switch will be able to decide, which input the mux needs to send through.

3.4.12 PWM

A PWM will be required to control the motions of the servos that are dispersing the pills to the user. To change the angle of the servo in the Medlock difference length pulses from a PWM will be used. For full range of motion pulse widths ranging from 450 to 2450 us will be used. These values respond respectfully from 0 degrees to 60 degrees, which is the maximum range of the servo. While it is possible to get standalone solutions for PWMs it won't be necessary as the CC2650 has built in PWM functionality. This is accomplished by using any of the GPTMs that are included on-chip.

3.4.13 Locking the Device

This device is meant to help stop opioid addiction, in order to do that the user of the device should not be able to open the device easily. The device is not deigned to be impossible to break into, it is merely a device to help control dosages of medications, if the user does find a way to open the case it will be logged that the case is opened and the user will not be able to get a refill on medication. A big part of keeping the user on the outside of the device is installing a lock that keeps the door of the device closed. The lock needs to be secure and strong as well as being difficult to pick or make a replica key for. Some good lock choices for our device include a tubular pin tumbler lock, a laser cut key lock, and pin tumbler lock.

The tubular pin tumbler lock uses a cylindrical key on a four or eight-pin system, these locks are typically found on vending machines and computer security cables. The lock works is a similar fashion of a regular pin tumbler lock meaning that the pins in the lock must be compressed to a certain level in order for the lock to turn and open. The tubular pin tumbler lock is a shallow lock since the pins are in a circle rather than being in a straight line. The reason the tubular pin tumbler lock system works so well is because the key is incredibly hard to duplicate and are very difficult to pick without specialty picks. The key is a short hollow shaft in the shape of a cylinder, but has a larger diameter than a typical key. The pros for the tubular pin tumbler lock system are that it is short, compact, and very secure. This lock can be seen in Figure 14 below.

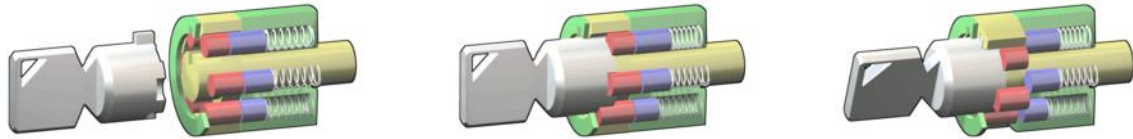

Figure 14: Tubular Pin Tumbler Lock [22, reprinted with permission from Wikipedia]

The internal cut, or laser cut, lock uses a rectangular key that is cut with a wavy groove on both sides of the key. The groove is a mirror image of itself on both sides of the key, this is so it does not matter how the key is inserted into the lock, and if the key matches the lock the lock will always open. Laser cut keys are very secure because in order to make a laser cut key a special key cutting machine must be used. The cut down the key is a constant depth and as said before in a wavy fashion. The pros about the laser cut key and lock is that they are very secure; it is very difficult to replicate a laser cut key and incredibly difficult to pick a lock designed for a laser cut key. The cons about the laser cut system is that a typical laser cut key is quite long and for our device we are trying to keep everything as compact as possible. Having a long lock on the inside of the device could work, but it will take up room inside the device that can be utilized for something else.

The pin and tumbler lock is the most popular lock. The locking mechanism is composed of the following, a set amount of pins and a set amount of springs. The pins are composed of two parts and vary in length; the spring is located above the pins and pushes the pins down. When a key enters the lock the pins move into specific positions, when the correct key is put into the lock the gap between the two components of the pin line up with the plug of the lock, shown in yellow below, and the lock is allowed to open. If the incorrect key is put in the lock then the gap in the pins will not line up and the lock will not be able to open. The cons of this lock, like the laser cut lock, is that it is long and will take up space inside of our device. The pin and tumbler lock is also very easy to pick with basic tools, making it not the most secure of the choices. The main pro is that the pin and tumbler lock can be modified making it more secure, but modifications cause the cost of the lock to increase. This lock can be seen in the Figure 15 below.

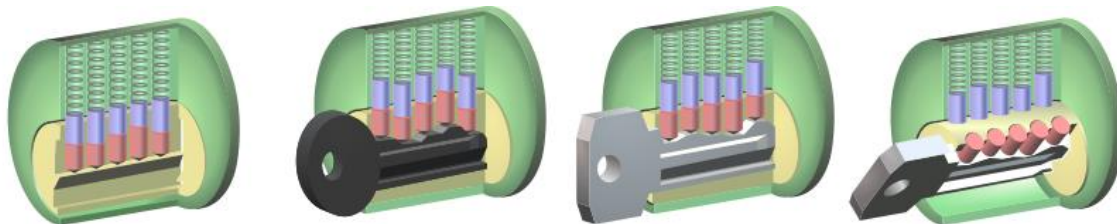

Figure 15: Pin and Tumbler Lock [23, reprinted with permission from Wikipedia]

The three choices presented are all widely accepted locks that serve some purpose. For this project, the tubular pin tumbler lock seems to be the right choice. The lock takes up minimal space inside the actual device because the lock is round and has almost no depth, it is very difficult to pick without specialty tools, and it is very difficult to replicate the key for a tubular pin tumbler lock. The tubular pin tumbler lock seems to be the most efficient and secure lock for the device that it will be used on.

4. Standards and Realistic Design Constraints

The following section will examine various standards and realistic design constraints relating to the production of Medlock.

4.1 Related Standards

Many people may ask “why should I care about standards?” Well in lots of ways standards help to drive our society as well as provide safety within our society. Standards from the FDA help to make sure that we don’t eat or drink any toxic chemicals. The CAA (Clean Air Act) established national ambient air quality standards so that we aren’t inhaling highly polluted air every day. These are just a few examples of how standards are here to protect us and provide reliable services. [24, reprinted with permission from IEEE]

In our case we won’t be talking about standards that are general knowledge and affect daily life like that of the FDA. That being said it doesn’t make them unimportant. The standards that will be explored in the following section range from engineering standards such as proper coding techniques to PCB standards, as well as medical regulations from the Health Insurance Portability and Accountability Act better known as HIPAA, these standards will prove important in the development and testing of our product.

Most of the standards shown will come from the Institute of Electrical and Electronics Engineers (IEEE), which represents one of the world’s largest technical professional organizations. This organization is also responsible for the passing of thousands of standards which are used every day in the engineering domain. Other sources for standards will include the International Organization for Standardization (ISO), the International Electrotechnical Commission (IEC), HIPAA, and the Association Connecting Electronics Industries (IPC).

4.1.1 HIPAA Regulations

HIPAA or the Health Insurance Portability and Accountability Act was passed in 1996 and provides privacy standards focused on the protection of patient’s medical records provided to doctors, healthcare plans, and other covered entities. For this paper the focus will be specifically on the protections of medical records for covered entities. “Covered entities are defined in the HIPAA rules as (1) health plans, (2) health care clearinghouses, and (3) health care providers who electronically transmit any health information in connection with transactions for which HHS has adopted standards. In this case PHI stands for “Protected Health Information” and the standard basically states the covered entities, things such as pharmacies, must have security safeguards to ensure the protection of a patients PHI. [25, reprinted with permission from NLM] [26, reprinted with permission from GPO]

4.1.2 Impact of HIPAA Regulations

There are often strict regulations that must be followed when it comes to information or products within the medical field. Most of these regulations are enforced through HIPAA, an act that ensure the safety of patients protected health information. The impact that HIPAA would have on our product isn't too concerning for our group when developing the product. These regulations come more into play if our product is entered into the market in the way in which it is planned. The product would go hand in hand with pharmacies which under HIPAA are considered a Covered Entity. In this case the pharmacists would have the responsibility of not encoding any information onto the LCD display that would violate the protection of a patients PHI. This shouldn't be a problem since in the ideal situation our product is a replacement for pill bottles in highly addictive prescription drugs. Therefore, the LCD display would be just like the printed information that is on a pill bottle now. Nevertheless, the HIPAA standards would need to be followed in such situations.

4.1.3 ISO/IEC/IEEE 9945:2009

This standard contains some specifications for how C-programming language code should be written. It also gives utility conventions and C-Language header definitions. This is one of several standards that involve writing code within the C language and what is considered proper and improper to do. This will end up being used in naming conventions, error handling, and defining functions and subroutines within our code. [27, reprinted with permission from IEEE]

4.1.4 ISO/IEC 9899

This may be the most important of the programming standards that are discussed in this section. This document describes all the basic rules for programming in C. The major inclusion is shown below.

- The representation of C programs.
- The syntax and constraints of the C language.
- The semantic rules for interpreting C programs.
- The restrictions and limits imposed by a conforming implementation of C.

While the standard specifies how many aspects are interpreted in C, there are limitations. This standard doesn't cover the data-processing within the C language. The other portion that is not specified in the scope is the mechanisms in which input and output data are transformed for use or when being produced by a C program.

4.1.5 IEEE 2003.1b-2000

This standard defines how to test various things in the C-Programming language code. This testing is based off other standards created by IEEE and basically

compiles how most, if not all C code should be written and tested. This standard basically shows how to test everything from the use of directories to inputs and outputs. It also contains conventions and general concepts for important aspects such as naming, primitives, and even timer operations. Overall this standard is a large compilation of information used for testing most C-programs against the previously established IEEE standards for which they should follow. [28, reprinted with permission from IEEE]

Programming in any language comes many different practices that must be implemented for the code to not only work but to work well. These common practices range from what libraries are available to naming specifications of variables and functions. This standard covers how C code should be written and tested against the previous standards that IEEE has deemed to be proper coding procedures. Therefore, this standard will work as a major point of reference for any questions when it comes to syntax for the proper use of the C-programming language against the standards set by IEEE.

4.1.6 Impact of IEEE C-Programming Standards

The impact of these standards will be wide ranging when it comes to the programming of Medlock. Since these regulations see over what is considered proper programming and testing of various components in the C language. Our project includes many aspects in which these standards will be used.

The first standard examined was ISO/IEC/IEEE 9945:2009. This standard will be a guiding factor when defining functions and subroutines. Further than that it helps to explain the proper utility conventions used within the C language as well as rules for defining headers. It will also help in the regulation of error discovery and handling while also providing information on language-specific system services. Overall the C language heavily relies on the proper understanding and use of the conventions. This standard regulates some of those conventions while also giving further information into them.

The second standard explored was ISO/IEC 9899. This will probably be the most used of the standards in this section. This document outlines all the syntax and constraints that often govern the writing of programs in C. Syntax is one of the most common mistakes when programming, due to the fact that syntax often changes based on which programming language is being used. It also explains all the semantics used for interpreting C. This helps to better understand how the program is seen. Lastly it helps us to understand how input data is represented when being processed and how output data is represented when being produced. All of these factors will be used and further examined throughout the creation of the software for Medlock making this standard crucial to us.

The final of the 3 IEEE C-Programming standards that was chosen is IEEE 2003.1b-2000. This standard should be the most crucial for our purposes as it

not only lays out many rules for which to follow but also testing methods for previously released IEEE C standards. The crux of this document goes over the assertions that should to be tested and the test procedures related to such assertions. Overall this standard should help our group to test various aspects of our code. The most crucial being the clock systems and overall conventions that are heavily used within C programming.

4.1.7 ISO/IEC/ IEEE 29148

This is a unified international standard called “Systems and software engineering — Life cycle processes — Requirements engineering” and it describes the process which should be used for the full life cycle of a system or software engineering project. This document not only describes the process for software engineering but also gives examples and insights into the proper way to document such. These documents range from those which are created with stakeholders in mind to those that are used solely for the use of the programmer. This standard is well regulated and as said before an agreed upon unified international standard, meaning it is accepted across the world. This document will help us to plan and create our software. [29, reprinted with permission from IEEE]

4.1.8 Impact of ISO/IEC/ IEEE 29148

When creating a project, whether it is a software system or a mechanical system, each has a process and series of steps that can be followed to standardize the creation and keep groups of engineers on the same page throughout the creation of the project. These steps often involve the documentation of ideas and the deconstruction of the overall system. By breaking a large system down into smaller more manageable portions or modules, a clear path can be exposed. Following the path more often than not will be beneficial to the group creating the project. In each different section of industry these models exist and when it comes to the Electrical and Computer Engineering fields the overlying standard that creates and guides this model is the ISO/IEC/IEEE 2918.

While our previous standards focused more on how the code should be written from a point of view of using the proper conventions and function processes. This standard focuses on the planning process for creating the program, maintaining, and documenting it. This document provides examples and steps for identifying what the software needs to do, showing it visually through graphs, and lastly how the actual code will be broken down and eventually written.

Using this standard as a baseline for the design process, we will develop out software and testing plans in conjunction with the ideas displayed in this document. While the creation of most of the models shown in the document would prove unimportant to the development of our project there are a few pieces that would prove helpful at least for the software side. The use of different UML

diagrams to further the understanding of how the software will interact with itself and the peripherals attached. Also, the decomposition of the system often produced during the software requirements specification portion of the document could prove beneficial in the separation of functions and features through cutting the system into smaller more “bite-size” pieces. Overall the impact of this standard will be felt in the preparation of creating the software. With a designated and specified plan being created prior to ever coding, the basis and understanding of the system will help to more cleanly and efficiently program a well-functioning overall system for the Medlock project.

4.1.9 IPC PCB Standards

The Association Connecting Electronics Industries also known as IPC, is a trade association with the goal of regulating and standardizing the assembly and production requirements of electronic components and equipment. This association is abbreviated as IPC because when it was founded in 1957 its name was the institute for printed circuits. This name was later changed in 1999 but none the less it has now been responsible for standardizing the production and assembly requirements of electronic equipment for 60 years, one such piece of equipment for which it provides many standards the PCB's or Printed Circuit Boards. These standards include requirements for acceptance testing, materials, documentation requirements, and quality testing. For the purposes of the production of Medlock there will be several beneficial standards for which to follow.

4.1.9.1 IPC-2221B

This standard is called the “Generic Standard on Printed Circuit Boards” it focuses on the design of printed circuit boards. It gives general information and requirements for the mounting of components and overall design for the PCB.

4.1.9.2 IPC-2220

This standard deals with the actual creation of the circuit board using CAD software. This standard works in conjunction with design further design standard in the 2220+ range to provide requirements when designing the circuit in CAD. It shows various design methods based of the type of PCB that is being created, whether it be flex, rigid, or multi-chip designs.

4.1.9.3 IPC-6011

This standard is called “Generic Performance Specification for Printed Boards” and it is used for the testing of PCB's. It has several performance specifications for the circuit boards and outlines ways of testing them. This standard can act as a test plan to ensure the quality of the created printed circuit board.

4.1.10 Impact of IPC PCB Standards

All the IPC standards previously listed will be crucial in the creation of Medlock. Medlock will use a printed circuit board for several key functions within it. Therefore, the design, creation, and quality testing of the PCB will be important in the development process. With that said the selected standards are each beneficial in their own right. IPC-2221B will be useful in the design of the boards as far as mounting the different components and the general information provided about the overall PCB design. IPC-2220 will assist the creation process in conjunction with IPC-2221B as it shall provide guidelines to follow in the designing of the PCB system using CAD software. Finally, once the PCB has been designed and created then IPC-6011 will be heavily important, because it will provide ways in which to test the performance of the PCB and also how efficient the design was. Overall all the standards discussed should prove to be critical in the design, production, and quality of the printed circuit board, which will in turn add to the effectiveness of the overall project.

4.1.11 IEEE 1625-2004 Battery Standards

This is an IEEE standard for rechargeable lithium ion batteries for portable computing purposes. On top of that it also provides practices for determining the operational performance of the batteries and their control and management systems as a whole. This standard provides everything needed for the proper design and testing of rechargeable batteries.

4.1.12 Impact of Battery Standards

The Medlock system will employ a rechargeable lithium ion battery system to allow portable use of the product. With portability being an integral part of the overall system the design and testing of the batteries abilities to work effectively will be crucial. The standard listed above should be beneficial in both the design analysis and overall testing practices for our battery system. With the unfamiliarity of the creation of such systems the standard will also possibly be a guide as to how to properly design such a system. As stated prior the Medlock product doesn't work without the ability to use it during daily life. Due to that fact this standard may prove to be one of the most important standards that have been discussed in such section.

4.1.13 IEEE 802.15.1 Bluetooth Standard

This also gives additional resources for those who are trying to implement Bluetooth devices. This standard is a bit different than the previous in that it was worked on by IEEE and a Special Industry Group to determine what should be in the standard. This standard is designed to help with the understanding and

implementation process of Bluetooth devices. This should be a helpful resource in the development of our Bluetooth coding and processes.

4.1.14 Impact of IEEE 802.15.1 Bluetooth Standard

This standard should prove to be quite helpful in the development of the Medlock system. With there being a lack of experience with the inner workings of Bluetooth and the variables that go with it amongst our group, this standard will help us to further understand the system as a whole before attempting to implement it. The additional resources within the document will help us drive forward in the development of this portion of the product. Therefore, this standard is beneficial to the research and development aspect of our Bluetooth module and programming.

4.2 Realistic Design Constraints

All systems contain several realistic design constraints that are used to implement a design successfully. The content in this section will explore each constraint that has a relation with the Medlock device first as an individual, once all constraints have been discussed; all the constraints will be applied as a set to the device design. Each constraint must be viewed as realistic in order to be considered as an individual as well as being part of the set of constraints. Every constraint mentioned below affects the design of the Medlock device in some realistic way, causing our group to perform enough research to determine what choices to make about the design of the device.

4.2.1 Pill Type Dispersal Constraint

This constraint has to do with the pill type that the Medlock device will hold. The design of the device is to hold only one type of pill at a time, dispersing however much the dosage is at set intervals. This constraint will cause us to focus on the mechanism that disperses the pills from the device. Since only one type of pill will be housed in the device at a time our concern with the dispersal is to make sure that the proper number of pills are being dispersed at the correct times. Only being able to dispense one type of pill per fill up will only allow the internals of the device, the pill holder and dispenser, to be a specific size to test one type of pill. That being said we will only design the device to work with one type of pill shape. There are many different pill shapes in the world, since we will only be testing one type with our prototype, minor adjustments may have to be made to incorporate different pill sizes and shapes. This constraint will cause our group to think of possible ways to change the internals of the device to incorporate different pill types at different times. Meaning, a possible feature that the device could have would be to have attachable and detachable pill holders and dispensers for inside the device itself. This would allow for easy changes in the medication that the device is holding. Once again the device would only be able

to hold one type of pill at a time, but a feature could be added to quickly change the pill holder and dispenser inside the unit to change the medicine type. This constraint will cause our group to ensure that the dispersal mechanism is working correctly for one pill type, and cause us to consider how to possibly change the internals of the device to allow for a quick change in pill type functionality.

4.2.2 Charge Capacity and Power Consumption Constraint

The battery charge capacity constraint for the device helps determine what kind of battery the device will use as well as how often the device will need to be charged due to power consumption. The aspects of the device that the charge capacity and power usage constraint effect are how often or long the battery must be charged in order for the user to be able to successfully use the device daily and how much power the device itself will use when operating normally.

The charge capacity constraint has one aspect to it that affects the functionality of the device, that aspect being how often or how long the device must be charged in order to successfully operate on a daily term. The charge capacity constraint is present to ensure that our group performs enough research on batteries to determine the correct battery for the device. The device would not be considered if it had to be charged every few hours, that would cause a major inconvenience for the user, making the user plan out their day ahead of time to ensure that they will be able to charge the device as receive their daily dosage of pills. A second aspect of the charging component of the device is the time it takes for the device to charge. It would not be considered practical if the device was able to last all day on one battery charge, but charging the battery took an extended period of time to completely charge. There are a couple problems that could come from having long charging periods, the main problem being that if the user forgot to charge the device at the end of the day, the device would need to be charge the next day, if that charge time was very long it would inconvenience the user by making the user stay at home for an extended period of time while the device charges to ensure that they receive their pills. The charge capacity constraint makes us focus on a battery that makes using the device as convenient as possible for the user.

The power consumption constraint is in tandem with the charge capacity constraint. The amount of power that the device consumes on a daily basis needs to be very low to help ensure that the battery of the device lasts as long as possible. This means that when designing the device, this constraint will make us focus on designing the device to consume as little power as possible when operating, meaning dispensing a pill, and being able to go into a low power mode or setting while not being used. We could incorporate the best type of battery, charge capacity wise, for our device, but if the power consumption of the device is too high the type of battery will not matter, the battery will never be able to support such power consumption for an extended period of time.

The two constraints mentioned in this section are two of the most important for the device. These constraints will cause us to focus our research on designing a device that incorporates a low power mode and well as low power consumption overall to ensure a long period of time where the device does not need to be charged. The charge capacity constraint will cause us to focus our research on finding a battery that is easily chargeable as well as quickly chargeable.

4.2.3 Size and Portability Constraint

The size of the device is a realistic constraint because the investor wants the device to be easily portable. Our group was given dimensions that the investor would like the device to fit in as well as a size comparison. The size directly correlates with the price constraint of the device, the smaller the components the more expensive the overall device will cost to manufacture. That being said, the economic constraint outweighs the size constraint when discussing the aspects of the prototype of the device. More focus will be put into determining what components will be used in the device according to price rather than size, that being said, the device will be larger than what the investor originally requested. The main goal is to produce a device that meets all of the functionality requirements that the investor has given us, although the size of the device is a requirement, the size constraint does not have an effect on how the device works, rather how convenient it would be for the user to take with them.

The portability of the device is very important because the user needs to be able to take the device with them wherever they go because of the time intervals that the user is supposed to take their pills. As previously stated, the price constraint outweighs the size constraint, so more time will be put into researching the best option of a component based on price rather than size. That being said, time will still be put into making sure that the final design of the device is portable enough for a user to take with them wherever they go. The portability constraint is present in this device to ensure that it is possible for the user of the device to carry the device around with them in order to take their daily dosage of pills. This does not mean that the prototype of the device must be convenient for the user to carry, but rather possible.

4.2.4 Economic and Time Constraint

A couple very realistic constraints that are apparent in the design of the Medlock device are the price it will cost to physically build the device as well as the time it will take to build and test the device. Both of these constraints have a major impact on the building of the device considering the economic constraint determines what parts we will be able to use to physically build the device and the time constraint determines how much time we have to perform research, build, and test the device to ensure that the device successfully does what it was designed to do.

The cost to design and build the device is a major constraint considering the following. Although our group is receiving funding from a private investor, we have not been given a specific price range to stay in, we have just been told to keep the price as low as possible. Having to abide by the investor's price rule will cause our group to do a lot more research before building because we do not have the luxury of building a device that has physical errors, scrapping the built device, and starting from scratch, doing that would cost too much money for our investor. Instead of being able to test by trial and error when it comes to the hardware of the system, we must be able to perform enough research to have the confidence that when we build the physical components of the device, they will entirely correct. Taking this action toward the building of the device will result in a minimum overall cost for the device.

Another economic constraint is based on the manufacturing price of the device. The Medlock device's manufacturing price needs to be kept relatively low in order to be considered as affordable to the potential users of the device. The being said and knowing the approach that our investor wants to take, our group will have to perform a good amount of research to determine what the best components to use for our device are. Compromises will be made because the best component on the market may be out of the price range for our investor. Our group will have to determine what components will work best with the Medlock device considering functionality as well as price.

Along with the economic constraint comes a time constraint. Since our group only has one semester to perform research and design the device and one semester to actually build and test the device, we need to be on a schedule that will allow us to do so with some slack time. The plan for the first semester is for every person in the group to perform research on a specific topic that is relevant to the device and the research paper, and write a previously determined number of pages on said topic. This will be done every week by each group member, allowing us to complete the requirements for the first semester ahead of time and allow for editing and discussion. Once the research and designing has been completed manufacturing can begin. With all of the research being completed, we will have a very good understanding on which routes to take on manufacturing the device, allowing us to successfully build and test the device. It should be known that at least two time constraints exist, those being a time constraint where the device is built and working, but not to its potential, on time, and a time constraint where the device is build and working fully to its potential, yielding the best possible results, but out of schedule and possibly late.

4.2.5 Safety

Safety is a constraint that appears in almost all systems. The device being built must be safe for the user to use and operate on a daily basis. Since our device has a lot of electrical components, a safety constraint would be put into place to ensure that the user does not get electrocuted while using the device and that

the device operates as designed. Another safety constraint has to do with the rechargeable battery. If the circuitry designed for charging the battery is not correct, serious problems could arise when charging.

A major safety constraint appears when electrical components are present in a device. The reason being is if all the components are not designed properly, problems could arise. A few to mention would be overheating, electrocution, and the device not working as designed. Overheating could happen in electrical components if the circuit is not designed properly.

Overheating could cause the device to malfunction or even worse, completely break. If the system were to malfunction or break, it would be a major inconvenience to the user and would obstruct the user from receiving their daily medication. Overheating could also permanently disable the device, causing a total rebuild of the electrical components of the device, meaning a complete failure of the functionality of the device. This would not only inconvenience the user but also fail to meet the requirements of the investor for our group.

Electrocution is a major concern in any device with electrical components. If a user of our device gets electrocuted while using the device major problems could arise like personal injury as well as lawsuits. This constraint will make us focus on designing the circuitry in a safe way, ensuring that all components of the system are grounded correctly and there are no exposed components that the user could accidentally or intentionally touch.

Rechargeable batteries come with benefits as well as safety precautions. If the user is not educated on how the battery must be charged then possible safety situations could arise. If a battery for our device is selected that must be drained completely before being charged again and the user is not informed of this, the user could unintentionally break the battery, which would cause the device to no longer work, or the battery could actually explode, causing the safety of the user to be considered. Just like the electrocution portion of this constraint, many of the same problems would arise if the battery of the device exploded.

The goal of the device is to prevent opioid addiction, if the device works as designed then it would be able to do so very well. If the device malfunctions for whatever reason a safety issue could arise, the main safety issue that comes from a malfunctioning device is improper dispersal of pills. What is meant by that is if the user is supposed to only take one pill every four hours but three pills are being dispersed every four hours, a possible overdose comes into the picture. The device needs to always work as designed to ensure the safety of the user in a sense physical and mental health.

This safety constraint will cause our group to focus on many components to ensure that the device operates as designed and never puts the user in harm's way. Much research will be done in order to determine the correct way to

implement certain components of the device as well as the determining the best way to design circuits for the Medlock device.

5. Project Software and Hardware Design Details

Along with the engineering standards and goals for this project other design constraints come into consideration during the prototyping of the Medlock. A premade microcontroller chosen in the parts section will be used during the initial testing and will also be used as a guide when doing the final design. With the size of the device being an essential aspect to its function the individual components will be forced into tight confines. This will lead to added concerns of noise in the system.

The Medlock will be designed with five main hardware subsystems including, a PAN, a security system, a display system, a power system, and a pill dispensing system. This document will include block diagrams describing the individual systems marked as part of the whole. An CC2650 device will be the processing unit with the complete controller used during prototyping and a similarly designed system for production. Additional consideration will be given to stretch goals including multiple pills being contained in the same system and making the actual device comfortably fit in a user's pocket.

The Medlock will also require software support to make the device interactive with both the user, and the pharmacist providing the medication. The software will have direct interaction with all major subsystems on the hardware side. This will allow adaptability for different applications of the device. Different standards and operations could be required for distributing a controlled substance as opposed to assisting a user in maintaining a strict regularly timed consumption of medication.

5.1 Hardware Design

The power system will be built around the selected parts. To make the device practical and familiar to users a similar theory to cell phones will be implemented. The device will plug into a wall outlet to charge an internal battery that will be able to last for two days with typical use before being plugged back in. Typical use will be defined by a pill taken every four hours with awake time being sixteen hours a day coupled with eight hours of sleep. The display will default to a basic screen with potential stretch goals or continuation after the initial roll out containing customization of the default display.

This voltage will then be sent through various voltage regulators and delivered to the appropriate devices. The power will need to be maintained always to insure the security devices are kept active as well as key pill reminders and dispenser systems are active and available for the user when needed. This will require reminders for both charging and pill dispensing. Reminders will be applied

through the PAN system connected to the user's device, LEDs, as well as a buzzer connected to the system.

The LCD will display the user's name, the time, and the time the next pill will be available for dispensing as well as a gauge to inform the user how much battery is left. This information will be stored in the non-volatile memory and displayed while keeping the device in a low power state. When the time reaches ten minutes prior to the next pill being dispensed the device will raise itself to a full active mode alerting the user of the upcoming pill availability. This will be done through an LED sitting on the front of the device near the LCD. When ten minutes past the availability of the pill, without having the pill dispensed, the buzzer will be activated to alert the user through a low noise that the pill is available in a less subtle way.

On top of the LCD there will also be feedback through the user's cell phone, if desired, as well a buzzer, and two LEDs. The cell phone connection will be through a Bluetooth module on a PAN. This will allow the user to easily decide whether the cell phone connection is desired or not. This will also require dedicated software on the user's cell discussed later in the software design section. The two LEDs will be connected using low voltage regulators. To have control over the on and off switches will be a mix of a data and a power solution. The white LED indicating a pill is ready will be controlled with a transistor connected to the output of the CPU through the GPIOs. This will be triggered by the software designed by the CPE side of the project. The red LED on the other hand will be triggered using diodes that activate when the battery voltage goes lower than the appropriate value. This will turn on the transistor and power the LED until the battery voltage increases beyond the 10% value again.

The final user interface device will be the piezoelectric buzzer. This will have a small variation available in volume through a menu with the buttons on the LCD. To power this device voltage will be sent through a PWM. The PWM will output a square wave at a given voltage to create an appropriate sound from the device. The buzzer will indicate medication is available several minutes after the time has passed. The trigger for the buzzer will be turned off if the medication is dispensed prior to the appropriate amount of time passing. The user will have the option to completely turn this off as there could be issues with buzzers going off in situations where sound could be inappropriate or the user simply doesn't want the noise for their own reasons.

An infrared sensor will feed information constantly identifying the door as either closed or open. For users that are elderly or require reminders of their medication, but aren't being prescribed narcotics or controlled medications this sensor won't really be relevant. On the other hand, for users of narcotics or other controlled medications this device will ensure no access is granted without it being marked in the log so pharmacists can know if users broke into the device for any reason. While this won't stop users from getting inside, it will allow

pharmacists to stop issuing renewals of the prescription should the Medlock have been tampered with.

The ADC will be an essential component to integrate data coming from outside the Medlock to the Medlock. The world exists in an analog state while the processor exists in a digital world. This means any interaction with from the sensor to the CPU will require a pass through an ADC first. Thankfully the chosen MCU has a built in ADC and an additional ADC will not be required.

The servos will be controlled by the CPU. The problem with this is that the CPU sends a digital signal and the servos are looking for an analog one. Initial thoughts included a DAC to send the appropriate signal. This was dismissed since the actual value sent by the CPU was irrelevant the signal telling the device to turn on was the only important part. A MOSFET easily fits the profile of a turn on device with a static voltage input being blocked when the device is off.

Considerations have to be made as to what technique will be used to program the microcontroller. Major concerns include availability of the necessary pins, cost, reliability, and board space. For OAD the increase in board space occupied while small is more than necessary and the attempt to make the Medlock portable demands size be a high priority concern. On top of the size issue the OAD has the usual issues involved in wireless solutions of possibly dropped packets and this can cause major issues when adding the main control system for the device. This is unacceptable and OAD was crossed off the list of possible solutions.

5.1.1 Block Diagram

The block diagram seen in figure 16 contains both the power system set in place and the individual components operating the Medlock. The different major design sections including power, display, security, and pill dispensing are sectioned inside dotted line boxes and marked. Colors are used to denote the individuals responsible for designing and testing the part indicated. The block diagram evolved with the project, but did not at any point contain actual part names.

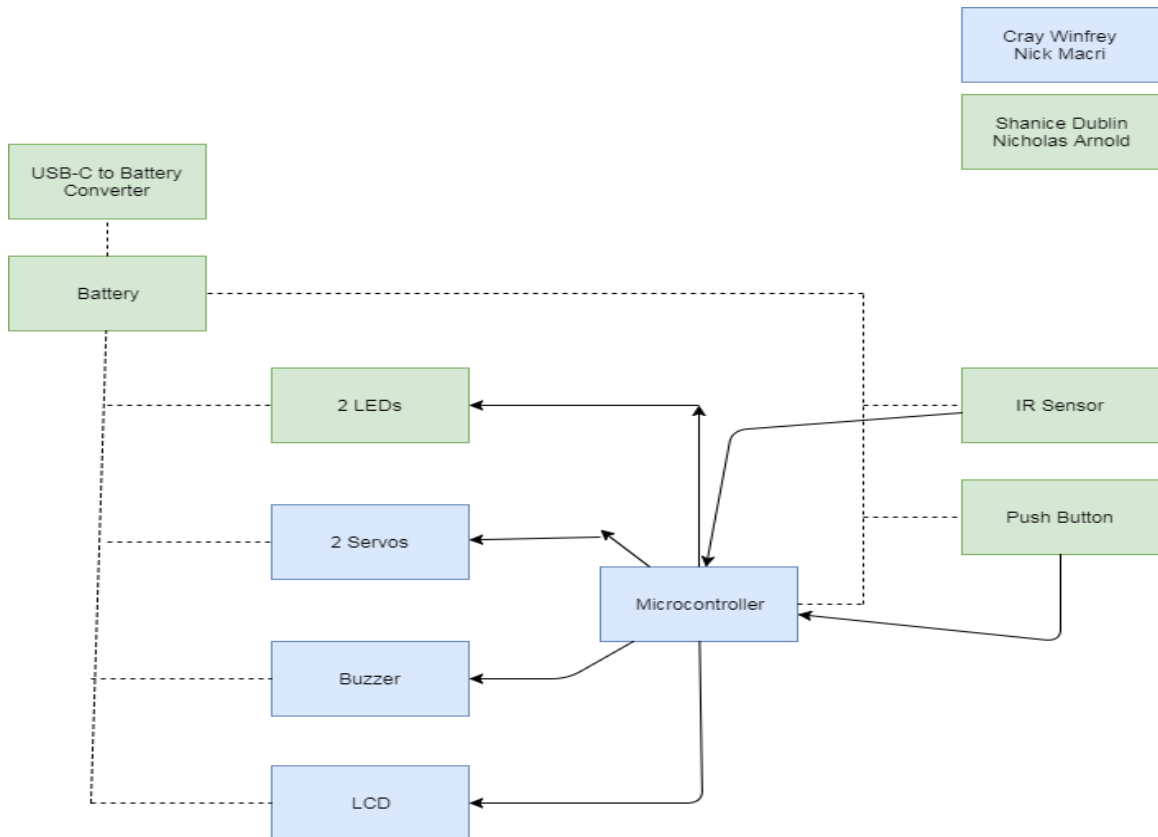

Figure 16: Group Member Responsibility Diagram

Battery overcharge is a concern for damage to the product as well as injury to the user. Excessive overcharge could cause a fire, which would be a concern to anyone carrying the device in a pocket, handbag, briefcase, or any other object on the individual's person. A battery can also over discharge. The most likely issue with these two occurrences is not fire, but simply a loss of battery life. This will require several sub-circuits as protection from both overcharging and over discharging.

First overcharging was tackled in several stages. The first issue with preventing overcharging is actual detection of when the battery is getting to the point of overcharging. To be overcharged the device would need to have reached a particular level of voltage, which would be specified by the manufacturer of the device. Figure 17 below shows the protection scheme for the battery.

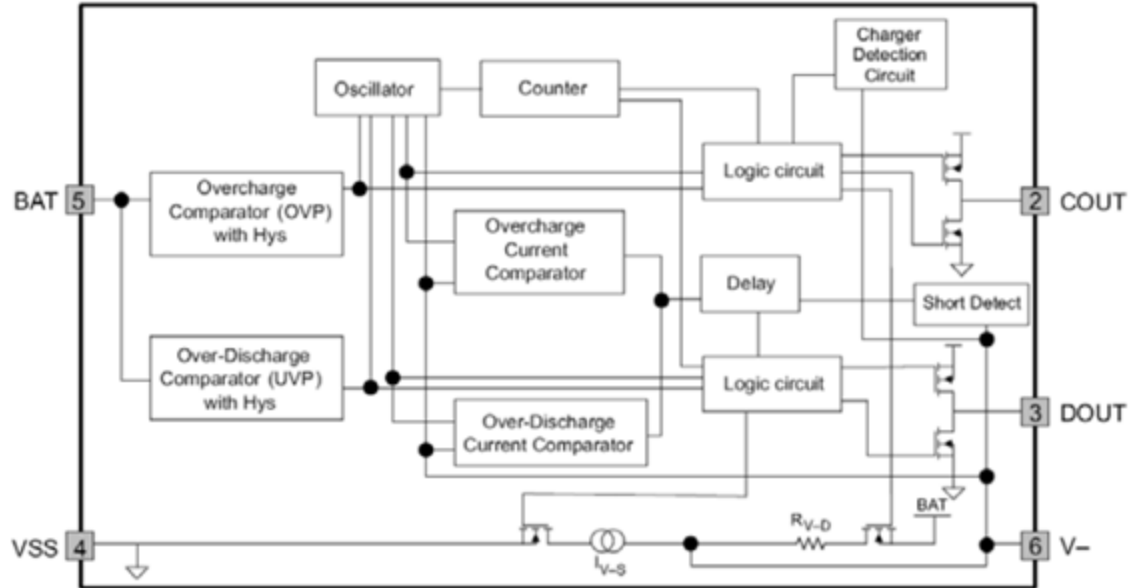

Figure 17: Overall Battery Protection Scheme [32, reprinted with permission from TI]

Not all parts seen in Figure 17 are always connected to the device. The Medlock being a portable device means it will have AC, 120 V at 60 Hz in the U.S., being used to charge a battery. A transformer is needed between the outlet and the battery to reduce voltage down to a useable level. The battery then powers a series of regulators to bring appropriate voltages to the individual components including LEDs, Bluetooth module, LCD, piezo buzzer, processor, memory, and sensors. For protection of the device diodes were chosen as a solution for transient voltage suppression.

The housing is of main concern for the Medlock. The Medlock requires a sturdy lock and a door that can be opened. The hinges required a subtle setup that was functional while also being incredibly small. This hinge as well as the miniature overall body of the device left no bezels around the left edge of the door.

To design the architecture of the PCB and the attached parts, Webench was used. This gave a clean professional looking schematic for the device. The spice style schematic was used for optimization and planning while designing and the software allowed a transition to a PCB style schematic that was sent to the manufacturer of the PCB.

5.1.2 Programming the MCU

JTAG and BSL are both common solutions for the MSP430, as well as the CC2650 supporting an ARM cortex, and have varying advantages. A major problem in this instance is the requirement of a UART connection for the BSL programming. With the current microcontroller, LCD, and servo device the only two possible UART connections are already in use. This brings up the question

of whether a different microcontroller needs to be selected. While this option was on the table the JTAG setup will provide programming through available GPIO pins and this also adds debugging options. There will be input from the pharmacist to the device. This does leave potential problems with the device even with well setup cleansing of the input from the user. This makes debugging a useful feature particularly during prototyping and testing.

Unfortunately, serialization is required to program CC2650 devices. While most modern computers lack serialization ports the decision required is onboard serialization or a separate tool to interface from a common USB port or an onboard connection that will handle the connection straight from the computer. With size being a major concern, the practical solution would be an additional device being available as an adapter. The user should not be accessing any of the coding behind the software and updates should be infrequent at most. With this under consideration the user won't require the serialization and manufacturers of the Medlock will have the option to roll their own serialization or get the one provided through this project.

The common technique to provide UART from the USB to the XDS100 series to emulate a COM port connection. For the ARM[®] Cortex[®]-M3 the V2 is the appropriate choice. This version supports Code Composer 4.x as a development environment.

5.1.3 Battery Charger

A description of the idea behind your basic Lithium Ion battery charger was described in the start of 5.1. In this section, we'll have a schematic for the actual charger being used and a description of what is going on inside the subsystem. Figure 18 following is the schematic for the circuit being built. This schematic covers the individual pin connections and was established with the help of Texas Instruments' Webench.

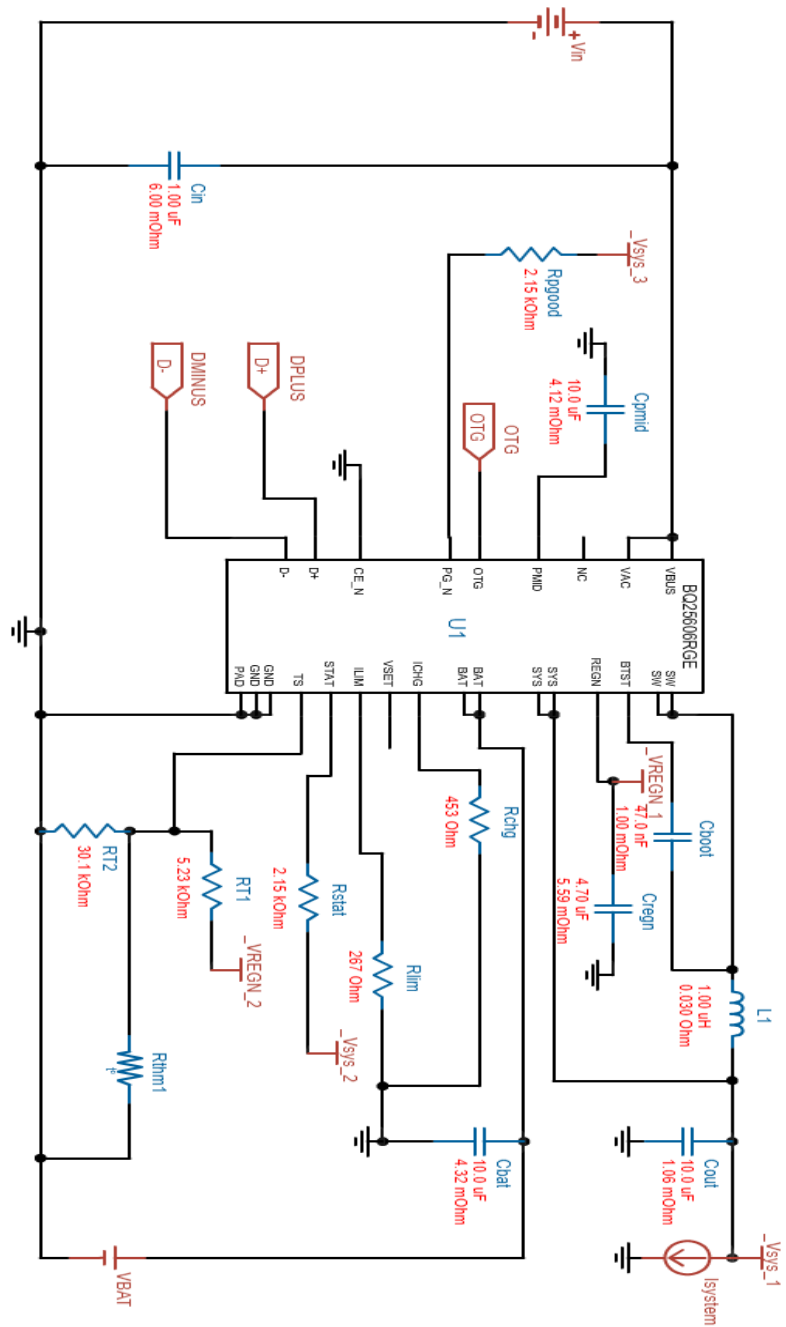

Figure 18: Battery Charger Schematic Subsystem [Custom design via TI Webench]

Lithium Ion batteries can be sensitive to input making a protection scheme in the charger essential. The input for the system will come from a standard USB-C port. Based on an available fast charging adapter that will be connected to the system with a USB-A to USB-C cable the DC input to the system will be between 5 V and 9 V coming in at 1.8 A. This will go through a USB-C header soldered to the edge of the board with the various outputs going to different locations. The power will first cross a small 1 μ F capacitor. This is necessary to filter out any of

the damaging noise coming from the source. The source line will terminate at both the VBUS and VAC. It's important for the capacitor to be both ceramic and as close as possible to the VBUS pin. Being ceramic has effects The VAC pin simply senses the power coming in and is thus shorted to the VBUS pin. The VBUS pin accepts the power to be used for charging. Following the VBUS pin is the NC pin, which must remain floating and shouldn't be connected or grounded to anything. PMID is connected to the VBUS via a MOSFET with the VBUS in the source and the PMID in the drain. The PMID will be connected to ground via a 10 μ F capacitor as per the datasheet specification. For the OTG pin there is the option between high and low. In this case the OTG pin will be tied to ground. There is no reason to make the Medlock represent itself as anything, but a slave to a host USB device. There are two BAT pins that respond to the positive and negative side of the actual battery. This charger is designed for a single series battery. The single battery lacks enough mAh and to expand on the time available before recharge the batteries can and are hooked up in parallel. The datasheet for the BQ25606 being used for this battery charger calls for a 10 μ F capacitor comes after the BAT pin and is parallel to the actual battery. This capacitor helps with larger current swings that can be seen when first starting to charge the battery. The Medlock has no reason not to be available for charging, which makes the CE_N pin, which is active low, ideal and requires nothing more than being tied directly to ground. There are two GND pins, one for power ground and one for signal ground. Both GND pins are tied directly to ground on the circuit. D+ and D- are linked to lines coming from the USB-C connection header to inform of data contact and charging port detection. The chosen Li-ion battery has a standard charging current of 1.5 A. To control this charging current a 453 Ohm resistor will be placed between the ICHG pin and a ground connection. This falls into the appropriate range for ICHG, which includes currents between 300 mA to 3000 mA. A main concern for the battery charger is protecting the battery from overcharging and over discharging. In the case of overcharging the VSET pin is used. For the chosen battery overcharging occurs around 4.25 V. To prevent the battery from reaching this VSET is floated. Floating VSET limits the charger to providing the battery up to 4.208 V. This is within the limits of the battery and will be used carefully as lowering the resistance can lead to the charge going as high as 4.400 V. This would potentially destroy the battery and require service for the Medlock. As a charging device, a lot of heat is created inside the BQ25606 and a thermal pad has been placed on the base to both allow the transfer of heat and as a connection point for grounding the device internals. In Figure 19 seen below is a more complicated view of the internals of the BQ25606.

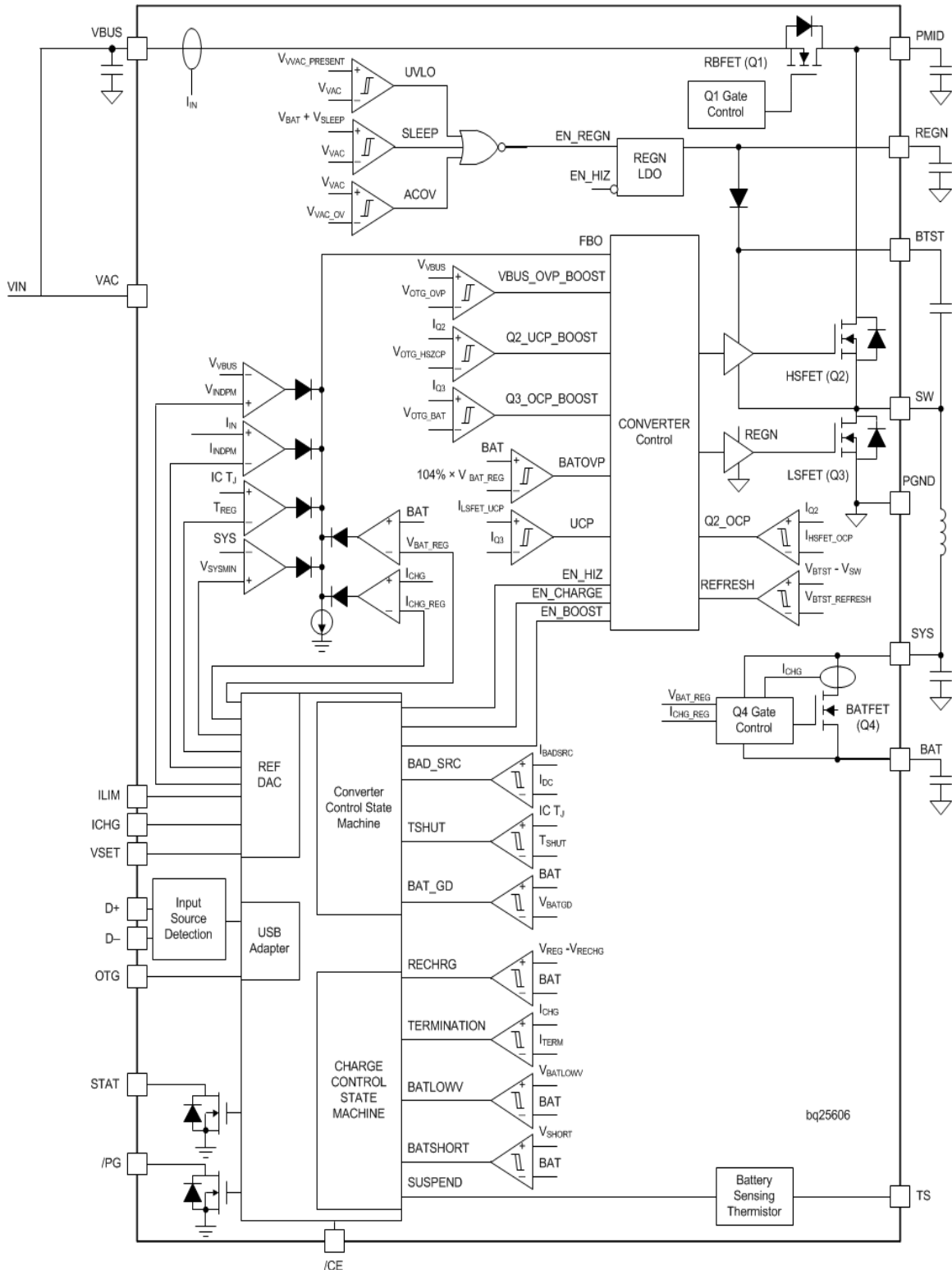

Figure 19: BQ25606 Internals [33, reprinted with permission from TI]

The BQ25606 has multiple pins that report on that status of the input as well as the status of the charging of the battery. These output pins have a common node

in the battery charging setup used. PG_N responds on several different status updates. The main purpose of the PG_N pin is to inform when the BQ25606 has a good input source. To check for a good input source multiple conditions, must be met. The chosen conditions by this device include settings for overcharge and undercharge. All comparisons for this pin are made against the VBUS. The system responds by setting PG_N to a LOW state when favorable conditions are met.

The STAT pin responds to whether the battery is being charged. There are three possible responses the STAT pin will output. These include a LOW output, a HIGH output, and a pulsing output that occurs at 1 Hz. The LOW output is an indication that the battery is being charged or recharged. A HIGH signal in the exact opposite respect indicates that the battery has either finished charging or has been placed in sleep mode and again stopped charging. If any of several conditions are met the device will be forced to stop charging and will emit a 1 Hz pulse from the STAT pin.

ILIM is not always a used pin. ILIM will be connected to a ground through a 267 Ohm resistor. This resistor will only matter when the D+ and D- pins don't recognize the source of power being provided. The ILIM pin sets limitations only inside the range of 500 mA – 3200 mA.

The TS pin works in conjunction with the REGN pin. The intention of the TS pin is to measure the temperature of the battery using a thermistor. There is to be a resistor divider between REGN and TS and ground. This will lead TS directly to the thermistor, which will lead to ground. The thermistor will have a negative coefficient causing the resistance to decrease as the temperature goes up. This supplies a voltage to the TS pin that will turn the charger on and off as it goes in and out of the appropriate voltage range. The REGN pin is part of the regulation of power transferred from the IC. It has a direct connection to the REGN LDO, which provides biasing to the internal components of the BQ25606.

The BTST, SYS, and SW pins connect through components to the same node as STAT and PG_N. This node leads the output of the battery and charging subsystem into the rest of the system to power the MCU and its peripherals. The BTST will have a 47 nF capacitor between the BTST and SW pin. This links the two outputs before going through a 1 μ H inductor before reaching the output node. This node will provide power either through the input to the charging system or when cut off from all power supplies, but the battery will be powered by the battery. The main output voltage and current come through the SYS pin. This pin leads directly to the SW and BTST line immediately after the inductor. After the three lines combine a 10 μ F decoupling capacitor is placed between the output line and ground. This capacitor is in parallel with the rest of the system. After passing the capacitor the power is placed on the input of the power distribution setup for the system.

The SYS pin is connected to the battery through the internal BATFET. The BATFET is controlled through an internal gate control with settings that were set through other pins describing the output of the battery charger system. The SYS pin also allows power to be delivered to the battery. The power will go through the BATFET while going into and out of the battery.

5.1.4 Power Distribution

Power distribution will be occurring as output from the battery charging circuit. The power will flow along a main rail that splits off to two different voltage regulators. These voltage regulators split off to multiple loads including an additional voltage regulator each. On top of that one of the second voltage regulators splits to a third level of voltage regulation. This hierarchy can be seen in Figure 20 at the bottom of this section. Following will be descriptions as well as specific schematics of how the voltage regulator (Figure 21) will be receiving and distributing power to the individual loads.

The TPS55330 will be the first voltage regulator and will be on the same level as the TPS6209733 voltage regulator. The TPS55330 will lead to six different loads all connected to the same base node. To start the 4.2 V coming from the battery will be connected to VIN on the TPS55330 voltage regulator. This value is well within the range of values accepted. This wide range will allow plenty of wiggle room for percentage errors in the parts. However, there will be two decoupling capacitors including a 10 μ F and a 100 nF prior to the VIN connection. The same line feeding into the VIN pin will continue down to the EN pin to activate the regulator. The Vin line will be connected to the SW pin across a 2.2 μ H inductor. After the inductor, the Vin line will cross a diode and reach a voltage divider. The voltage divider will have a 30.5 kOhm resistor that goes to the FB pin and then continues to a 10 kOhm resistor leading to ground. The FB pin is used to aid in voltage regulation allowing the voltage to be set with the voltage divider that it sits in the middle of. To control soft start programming a 22 nF capacitor was placed between the SS pin and ground. The AGND and PGND pins also connect directly to ground aiding internal components. Controlling switching frequency is relevant for such a major regulator and is set with the FREQ pin using a 60.4 kOhm resistor leading to ground. While the documentation calls for the SYNC pin either being used to help control synchronization using an external clock or being tied directly to the AGND pin, the power architect provided by Texas Instruments suggests leaving the pin floating. While following the advice of the power architect seems prudent, it also seems a poor idea not to test this setup in the prototyping phase. The DNC pin doesn't seem to be directly mentioned in the datasheet the architect leaves this pin floating as well. Considering the possibility that the DNC is being handled the same way as the NC pin it would be a good idea as well to keep an eye on this pin and connect it to ground if errors can't be solved. Finally, the COMP pin goes to a 1.1 nF in parallel with a 1.27 kOhm resistor in series with a 56 nF capacitor. This pins setup will have effects on the corrections caused by the FB PIN. Going past the voltage divider away from the

regulator a 47 μf capacitor is placed in parallel with the six loads placed on the regulator. [34, reprinted with permission from TI]

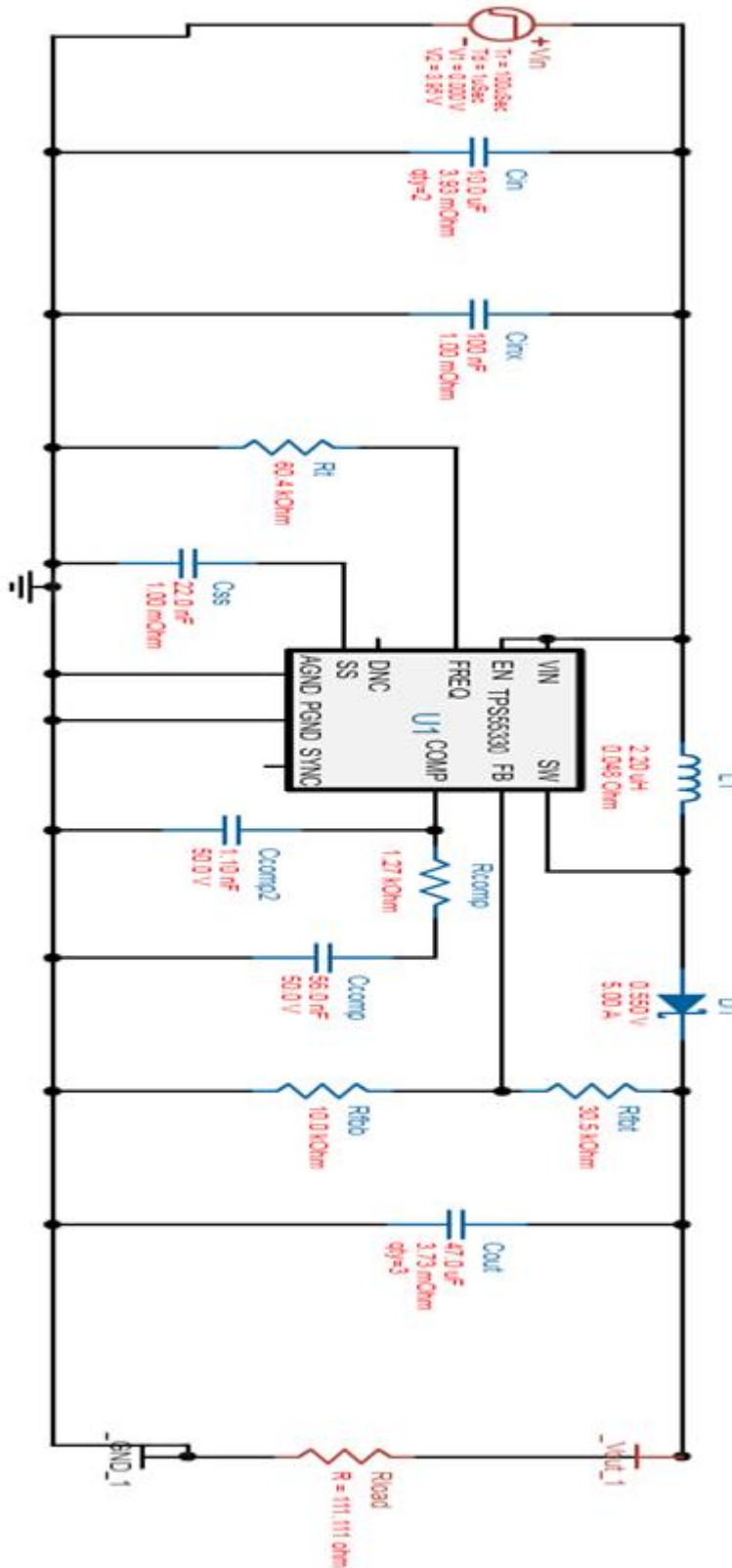

Figure 20: Main Portion of the first supply [Custom design via TI Webench]

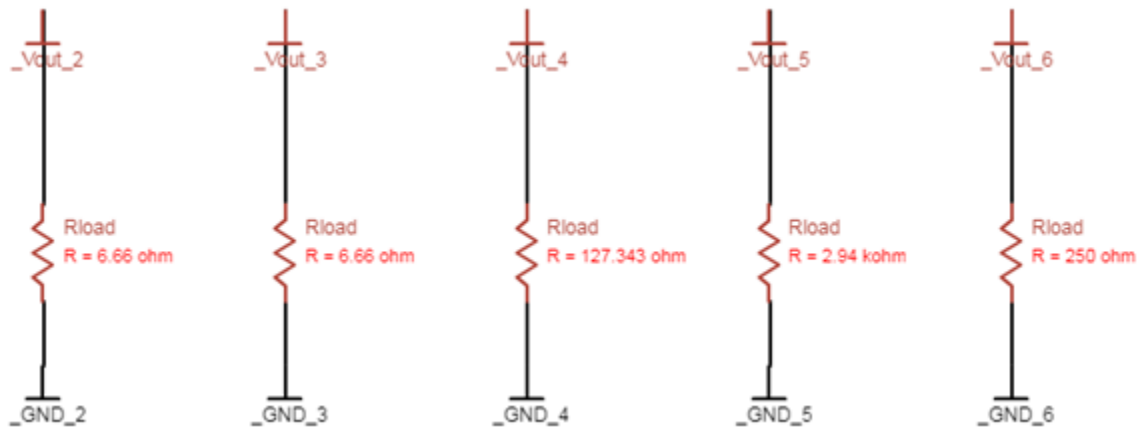
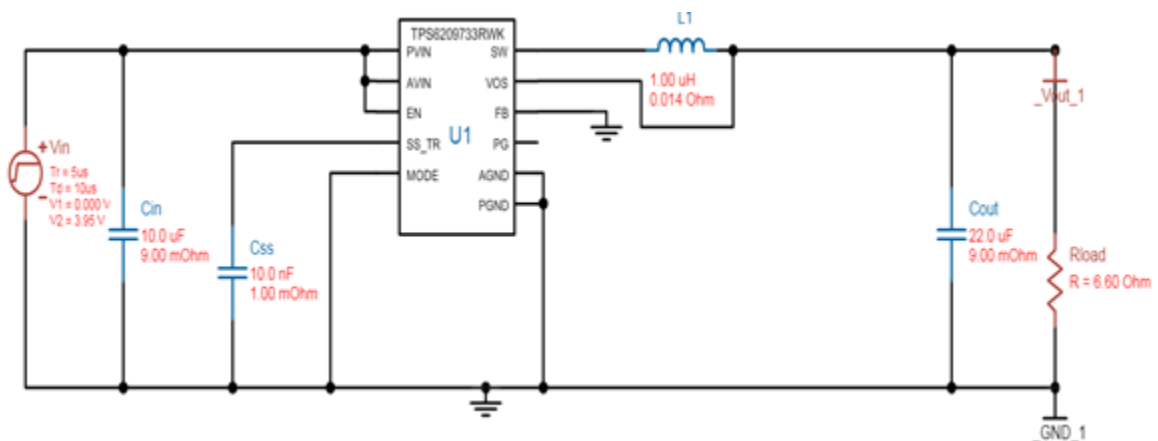

Figure 21: Load layout of the first supply [Custom Design in Webench]

The second voltage regulator on the top level is connected on PVIN, AVIN, and EN to the main rail in parallel with 10 μ F capacitor. This provides power as well as enabling the voltage regulator simultaneously. The SS_TR pin connects through a 10 nF capacitor to ground. This small resistance should provide a comfortably long startup time. The MODE pin will be tied directly to ground allowing automatic switching between PWM and power saving mode. The SW pin goes across a 1 μ H inductor past the 22 μ F output capacitor to the parallel loads. After passing the inductor the output of the SW pin loops back to the VOS pin to help maintain the appropriate output. The PG pin is left floating as it's not used and the PGND plus AGND pins go directly to ground. This is clearly demonstrated with Figure 22 below. [35, reprinted with permission from TI]



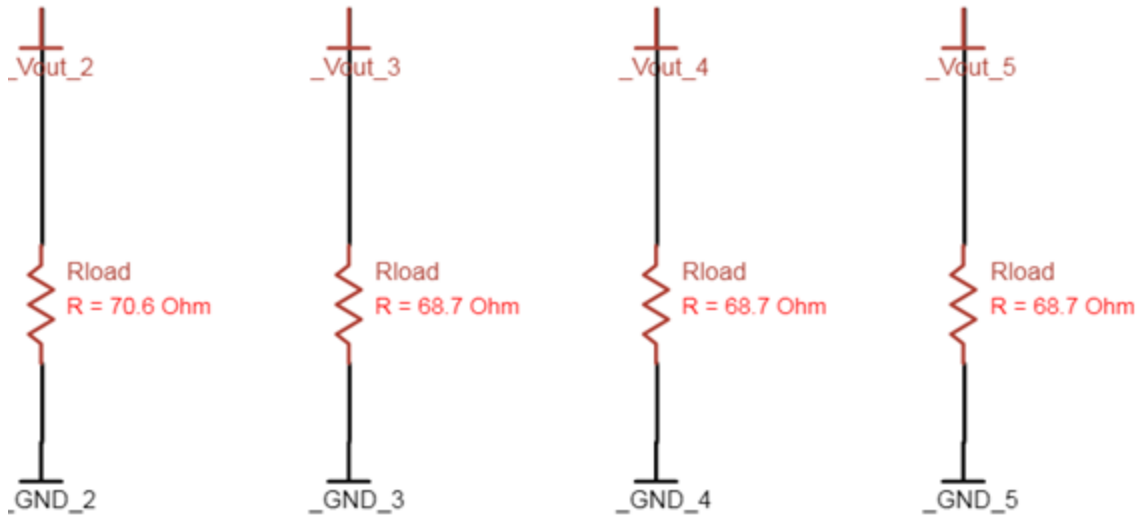

Figure 22: Top: Regulator setup with values Bottom: Loads attached to regulator output [Custom design via TI Webench]

The fourth voltage regulator has a 3 V and a 138 mA output. The voltage input from the second voltage regulator goes to the VIN pin, which is in parallel with a single 22 μF decoupling capacitor. There is a 1 μH inductor that connects the L1 to L2 pin. The PS/SYNC pin is tied directly to ground activating the power save mode of the regulator. The VINA and EN pins are tied together and then go to ground through a 100 nF capacitor. This VOUT goes to a voltage divider in parallel with a 22 μF output capacitor. In series with this connection is another voltage regulator and a 100 nH inductor that leads to a 4.7 nF capacitor in parallel with the piezo buzzer acting as a load and controlled by the MCU. The voltage divider starts with a 715 k Ω resistor that leads to the FB pin and continues to the 143 k Ω resistor that leads to ground. The FB pin will be used for correcting the output of the voltage regulator. The PG pin is an output used for knowledge of good output and is left floating instead of being a readout for this design. The thermal pad is tied to GND that is tied directly to ground. The Rload connected to _Vout_2 is separated to show that it's a separate voltage regulator only in this Figure 23. [36, reprinted with permission from TI]

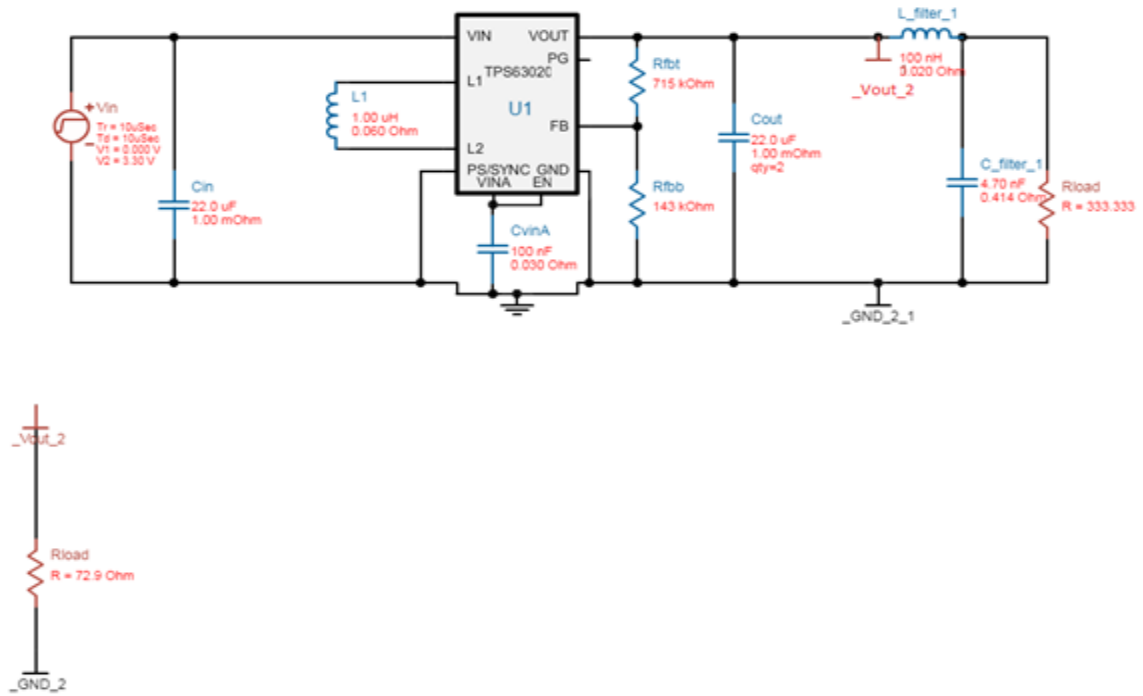

Figure 23: Fourth voltage regulator [Custom design via TI Webench]

The last voltage regulator is the LP5907DQN. This regulator has the voltage coming from the fourth regulator going to the VIN and EN pins while being in parallel with a 1 μ F capacitor. The VOUT pin leads to the final load in parallel with a 1 μ F output capacitor. The EP and GND pins are tied directly to ground as is seen in Figure 24 below. This is a much simpler design than the other voltage regulators, but the requirements were not as strict to power the red LED as the other devices. [37, reprinted with permission from TI] Figure 25 shows the overall power system.

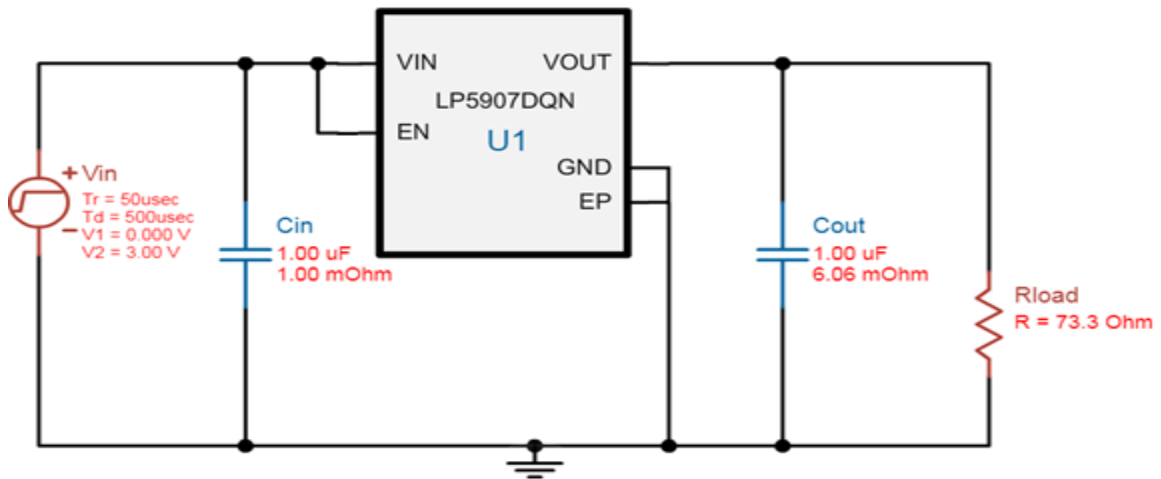

Figure 24: Fifth voltage regulator [Custom design via TI Webench]

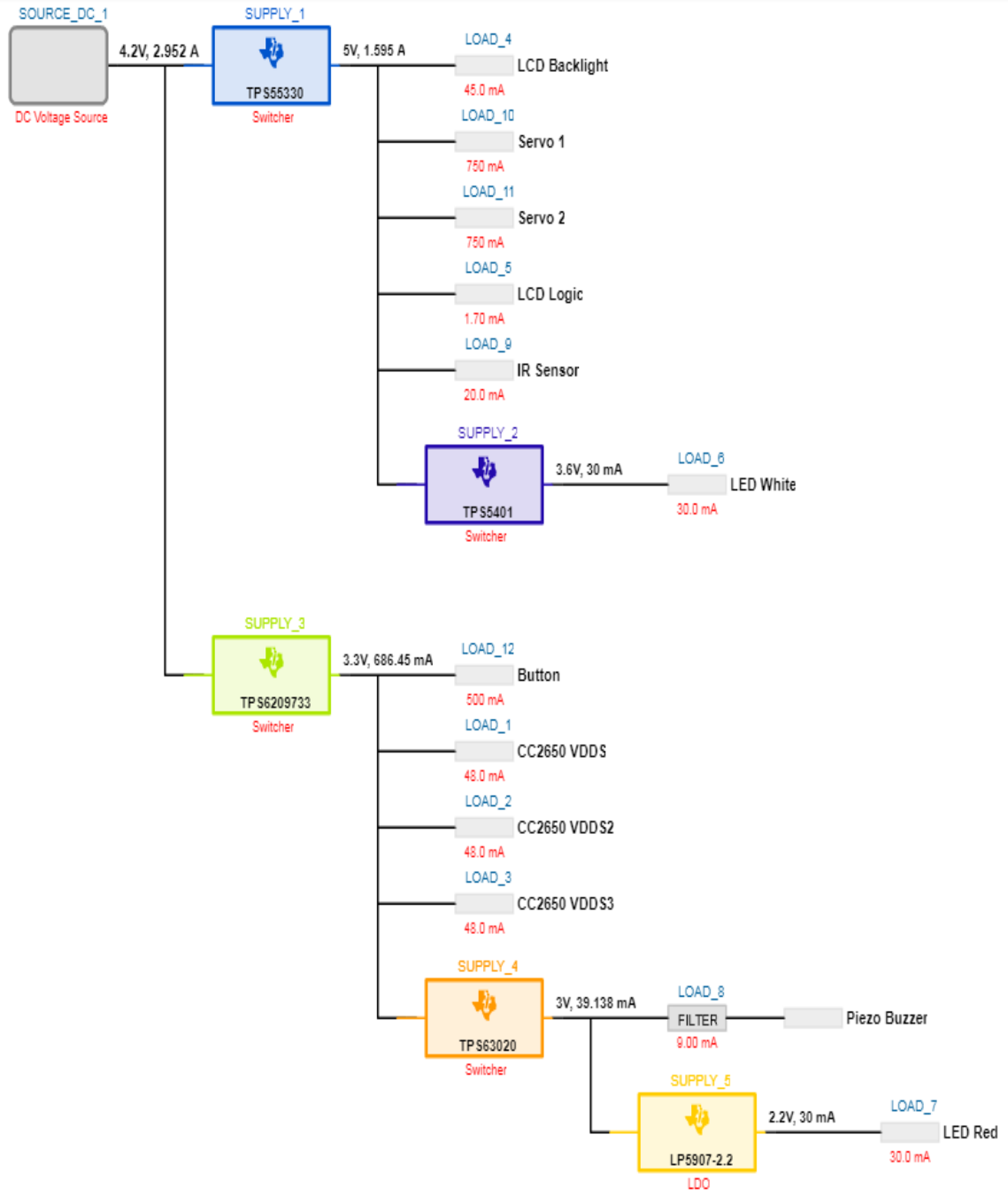

Figure 25: Overview of Power Distribution [Custom design via TI Webench]

5.1.5 CC2650 MCU Layout

The CC2650 will be the core of the device. When piecing together the subsystems to tie into the grand scheme of the MCU, a number of considerations were faced such as which connections needed to be where and how they needed to be connected. In the schematics below, the connections to the other devices will be laid out. All pins will be accounted for and explanations on the multiplexing of UART inputs will be laid out. The RGZ package was chosen for this design containing a 48-pin VQFN setup with a 7 mm x 7 mm footprint. The device operates with a .5-mm pitch for the PCB connections.

To start the CC2650 requires power being brought into the device to operate. This can be done in multiple different ways depending on the use of the device.

While the power connections are the defining point of the entire system, knowing where they go in relation to the components proved to be an interesting and time-consuming task. Knowledge on transistor layouts, pin mapping, and understanding how a part will react to the network was important. The connection between the MCU and the LCD takes place on the first 10 GPIO pins of the CC2650 for simplicity. On the LCD module, the supply voltage, VDD, and the LED backlight, labeled LED_A in the datasheet but A in the schematic, are connected to the switching regulator outputting 5 V. The input voltage for the LCD, VEE, controls the contrast of the characters on the LCD. Grounding this pin would give it the highest contrast making it easier to see the characters on the screen though, for calibration purposes, it is connected to a 10k potentiometer where the top pin is supplied by the same regulator as the LCD and the bottom pin is grounded. The data/instruction signal pin, RS, is the first connection to the MCU since a high reading on it creates a flow of data while the read/write mode pin was grounded for the write mode to be active since there would be no reason for the LCD to read in any data for the MCU to use. The rest of the data pins were placed on the next sequence of GPIO pins to output the characters on the screen. There was no worry about inserting external resistors due to the option of pullup or pulldown resistor available internally in the MCU.

As for the IR security sensor, the design between a standalone testing and connecting it to the CC2650 was simplified greatly. Instead of using an external comparator and 555 timer, the pins of the MCU are capable of acting as timers/PWMs given the correct code is used to program the device. A deeper explanation of the coding process will be given in section 5.2.1.3, but the IR LED and the photodiode are supplied voltage from the same 5 V switching regulator as the LCD with the cathode of the IR LED grounded and the anode end feeding into the MCU. This is shown below in Figure 26.

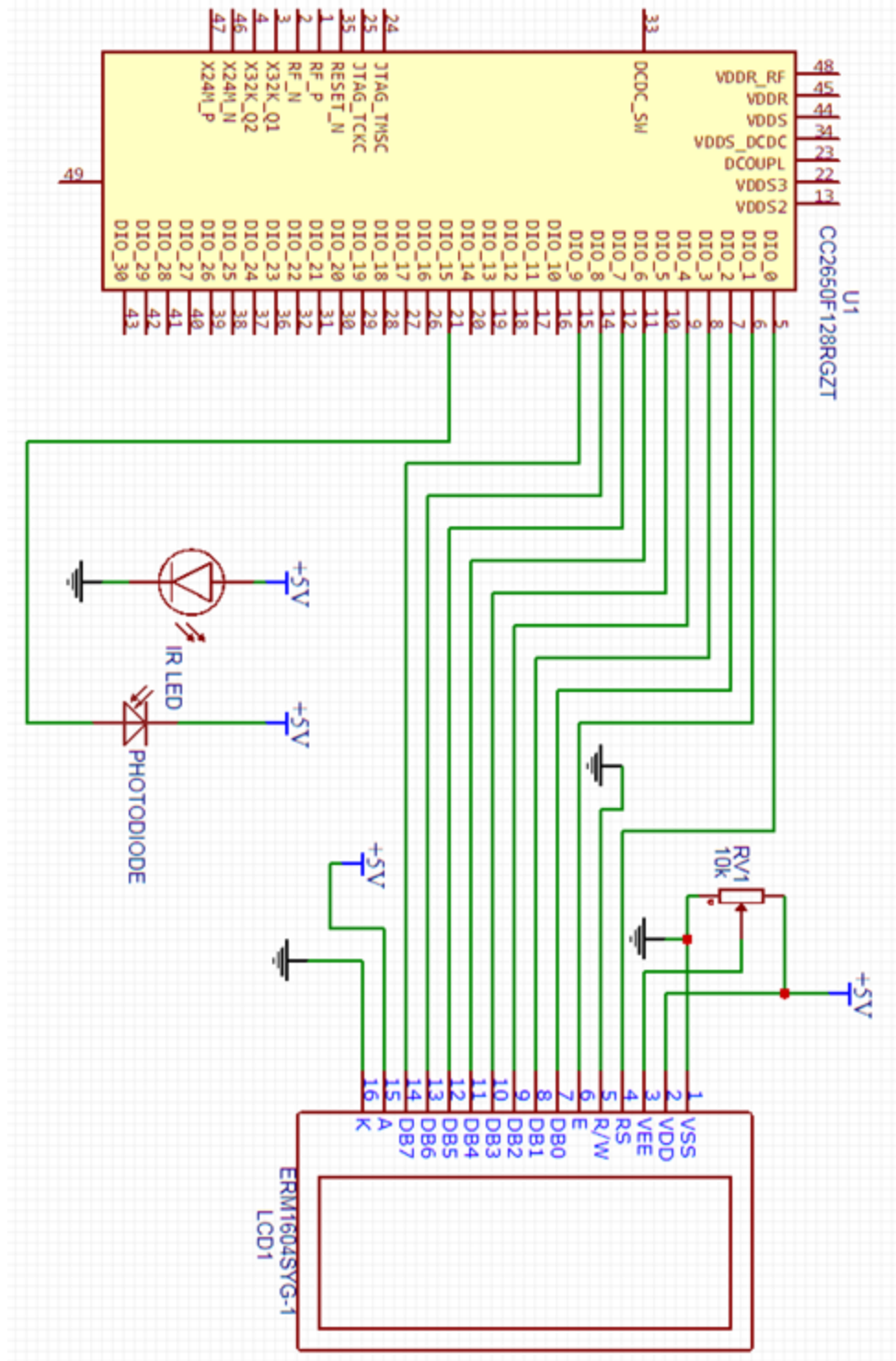

Figure 26: MCU to LCD and IR Sensor [Custom design created in EasyEDA]

Figure 27 below displays the CC2650 with pins 16 through 20 connected to the LEDs, piezo buzzer, and servo motors. In the above figure, it was shown that both the LCD module and the IR sensor had uninterrupted communication with the MCU however that will not be the case for the other aspects of the user

interface. Because having the LCD one at all times would spend more energy than needed, heating up the entire unit unnecessarily, and sounding the buzzer at all times isn't a reasonable or viable option, transistors have been placed to act as a switch to either turn them on when needed or off when not. For the LEDs to reach their forward voltage at the supply of the regulators, the anodes have been connected to the emitter end of the transistors, likewise with the buzzer. Also, despite the fact that the MCU has its own pullup/pulldown resistors, transistors are known to have some amount of leakage current from out from the base so the extra amount of resistance is just used as a precaution. The amount of resistance used can also be negligible because the purpose is for the transistor to recognize whether it's receiving a HIGH or LOW signal to enable itself or not.

The servos, on the other hand, do not require this additional transistor due to an internal one shown by their own pin layout. The SIG signal pins are attached to the MCU while the V+ supplies them with the 5 V regulator. This way the servos will only dispense medication when the signal from the MCU reads HIGH.

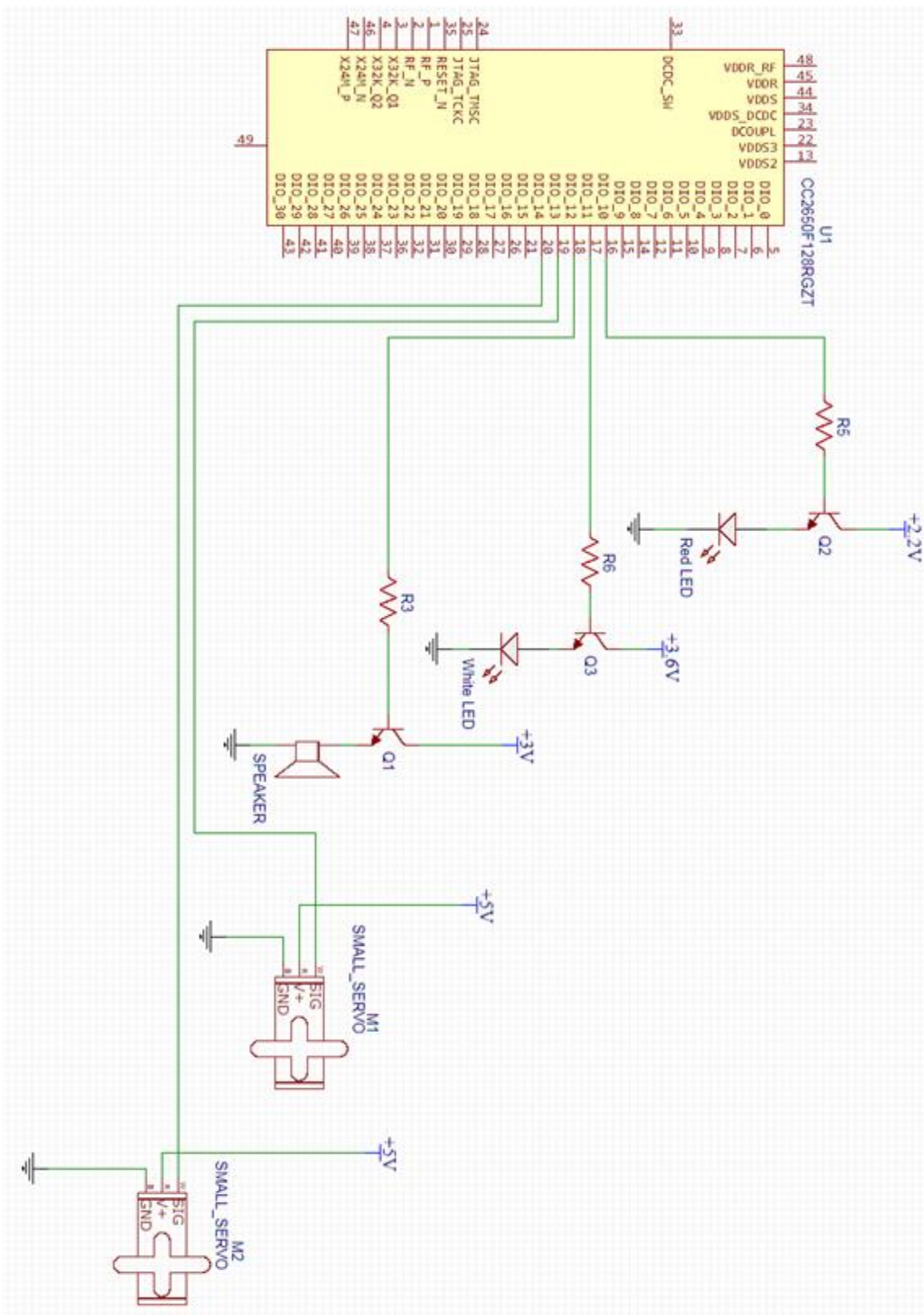

Figure 27: MCU to LEDs, Buzzer, and Servo Motor Units [Custom design created in EasyEDA]

5.2 Software Design

In the Medlock system, the design of the software will be crucial to the functionality and overall effectiveness of the system. The software will be used to execute many of the features within the system. These features include the dispensing of the pill, the notification system that tells the user when the pill is ready, the LED display, controlling the servos, and lastly recording the times in which the casing is opened. All this will be done using a TI CC2650 microcontroller. Overall the software will be an integral part of the creation of the Medlock system.

Disclaimer: When talking about the use of a microprocessor in the following section, we may test some software functionality on a launchpad, but in the final project the chip will be on a PCB.

5.2.1 Programming Language

In order to code the electrical components of the device a language has to be chosen to write in. There are a couple widely accepted languages that would work for our device, those languages being C, java, and python. Each language has its own unique features that could benefit the device's design and each also has drawbacks that take away from the functionality of the device.

5.2.1.1 Python Programming Language

Python is an interpreted language that excels in code readability. The python coding language is very similar to writing code in English, it uses white space to in the code to identify where a code block begins and ends. Python is a very simple yet powerful language; the idea behind the language is that python's syntax allows programmers to write code in fewer lines than other languages like C or Java. Being able to write fewer lines of code and perform high-level tasks typically helps reduce the amount of errors in the code, and because python is an easily readable language, finding the errors is not usually difficult. Python uses an automatic memory management system as well as a dynamic type system; this allows support for many paradigms as well as a standard library. The drawback for python is that it is usually used in applications and is often difficult to implement into microcontrollers, which is a huge portion of our device.

5.2.1.2 Java Programming Language

Java is known as an object oriented programming language that is class-based. In java, code is written in classes and methods, confined by curly brackets. When a class is written it can be implemented anywhere inside of the code that is being written. Methods can be used in a similar fashion, typically methods are written inside of the program class, it performs some operation on the input data and gives output data. When a method is called parameters are usually passed into the method, these parameters are the input data that the method will operate on. The main pro that java has is that once a code is written in java, the code can be

run on any platform that supports java. This makes sending code across different platforms very easy because the code should always run. The main con about java is that, like python, it is typically difficult to implement into a microcontroller, and our device does not need objects to function correctly, so we do not need an object oriented language.

5.2.1.3 C Programming Language

C is known as a high level general-purpose imperative programming language that separates code into structures and functions. Much like Java, functions are blocks of code that take an input through parameters and give an output to the portion of code that called the function. Structures are used to group data inside of the code, when a structure is created, it creates a new data type that can hold any type of data the programmer desires. The main con with C is that it is a very finicky language, and will often compile with errors located in the code. The main pro is that C is often used in embedded systems meaning that C is widely accepted in microcontrollers. Being easy to implement in a microcontroller will expedite any issues that could arise when trying to implement other languages into a microcontroller.

5.2.1.4 Language of Choice

All mentioned languages have benefits and drawbacks in coding, however C seems to be the best language for our device. C being widely used in embedded systems and being easily implemented in a microcontroller will allow for fast installation and ease in coding. Since our code is going to consist of many different parts that perform different task, utilizing C's function and structure aspect will make the code easy to read and efficient. Although C can often compile with errors and do other usual things, we feel that it is the best choice for our device and will allow the device to function correctly and efficiently.

5.2.2 Software Functionality

For the purpose of simplification, the software will be broken up into several main functions. Each of function will serve to carry out one of the major features of the system. These functions will be carried out through the programming of the previously listed CC2650 Microcontroller. There will be several different types of pins used in creating these separate functionalities. For instance, various pins will be used for the producing of words on the LCD display, while GPIO's will be used for the movement of the servo motors. The overall software will need to be diverse in that we will need to use many of the different types of pins and functions within the microprocessor and the C language to properly achieve the desired functionality of the system.

5.2.2.1 Pill Dispensing Mechanism

The pill dispensing mechanism for the Medlock is one of the most crucial aspects of the project as a whole. With the main concern of the project being the prevention of the abuse of prescription medications, especially opioids, the pill dispensing must work properly. The functionality needs to make sure that only the proper dosage is dispensed at a time as well as it being dispensed at the correct time. This factor makes it so the mechanism is an intangible part of the overall success of the project.

The physical mechanism that we plan on using is similar to an upside-down Pez dispenser. This creates a bottleneck so that only one pill will be dispensed at a time. The bottom of the dispenser will have a plunger mechanism that pops the pill out. The plunger is controlled by the servo motor, which will be controlled by a push button on the microprocessor, if the mechanism is to work as planned then there are several aspects within the software that our group must be aware of and focus on.

When it comes to the software aspect, the first thing we will need is a few variables to control the overall system. We will require a timer that will determine whenever the 4 hours or the overall time required in between dosages have been satisfied. This variable will be a Boolean type which returns true every time the time period has been satisfied. When that is true then the push button will be approved to move the servo motor. Therefore, the only time the push button will work is when that variable returns true. Then when the button is pressed the push button will be active and move the servo and plunger. There will also be a variable recording number of pills remaining. Based on the prescription the total number of pills will be recorded into the system. Each time a pill is dispensed the total count will be decremented. Once that count hits zero then a notification will be sent out telling the user they need to refill their prescription.

Other aspects within this class will be in the scenario in which we have multiple pill dispensing mechanisms within the Medlock. This would occur when there is a need for a large number of pills. In this scenario, there will be a variable counting the number of times a pill has been dispensed. Then when that variable hits the value of the maximum capacity of a singular Pez dispenser like piece within the casing, once that value is hit there must be a solution in place to switch to the other dispenser within.

An important aspect to note in this section along with the notification section is that the timer between pill disbursement is only reset when the pill is disbursed. This functionality makes it so that a user for instance couldn't disburse a pill at 7:59 that was supposed to be taken at 4, and then dispense the next at 8. Therefore, rather than the times being static they are dynamic in that if the pill is disbursed 30 minutes after it was supposed to be then the next pill will be available 4 hours after the time the pill was disbursed as opposed to 4 hours following the time it was supposed to be taken.

5.2.2.2 Notification System

The notification system is a multifaceted system. This system comes into play when the required time between the disbursement of pills has been met. The system has 3 different aspects within it. These aspects include a notification via the Bluetooth module, a visual alert, and an audible sound, the order being the Bluetooth notification going to the phone while the visual alert is also occurring via LED's. Ten minutes after those if the pill has yet to be dispensed by the user then an audio alert will be activated. This choice of functionality is for the scenario in which the user is in a public setting, maybe work or just out running errands, this way there isn't an obnoxious alert interrupting someone while in an important situation such as a meeting or interview.

5.2.2.2.1 Bluetooth Notifications

The Bluetooth notifications will be sent from the CC2650 which has a built in Bluetooth module. It has the capabilities of connecting to Android and iOS devices. The functionality of this will be that the user connects to the Bluetooth module, most likely via their phone, seeing as the module is compatible with IOS and Android, almost all smart phones will have the capability to receive notifications from it. Once the user is connected they will receive a notification on their phone whenever their pill is ready to be disbursed. This will be the first portion of the notification process along with the visual blinking of the LED.

Software design wise the overall functionality for this portion is for a notification to be sent from the MCU to a phone telling the user when their pill is ready. This will require a Boolean variable to tell the MCU when the pill can be disbursed. The Boolean will begin as false and will be flipped to true when the time reaches the specified time between pills. Once this occurs the notification will be sent out. This is a major simplification of the process. As you will see in this section, this portion of the software will require the setting and use of connection parameters and a further understanding of how the MCU interplays with the various cellular devices. All of this will be explained in greater details as this section continues.

This section of the software design will be one of the most difficult sections of programming within the project. The TI CC2650 can act as a Bluetooth module while still maintaining its microcontroller responsibilities. This microcontroller is also the only one that TI provides which can connect and interact with both android and iOS. The microcontroller uses a low energy protocol stack for the use of Bluetooth capabilities. For the product to connect with a mobile device there is a built in GAP (Generic Access Profile) layer. "This layer is in charge of handling access modes and procedures of the device such as link establishment and termination, device discovery and configuration, and the initiation of security features [39, reprinted with permission TI]." Figure 28 below shows a state diagram for the GAP layer.

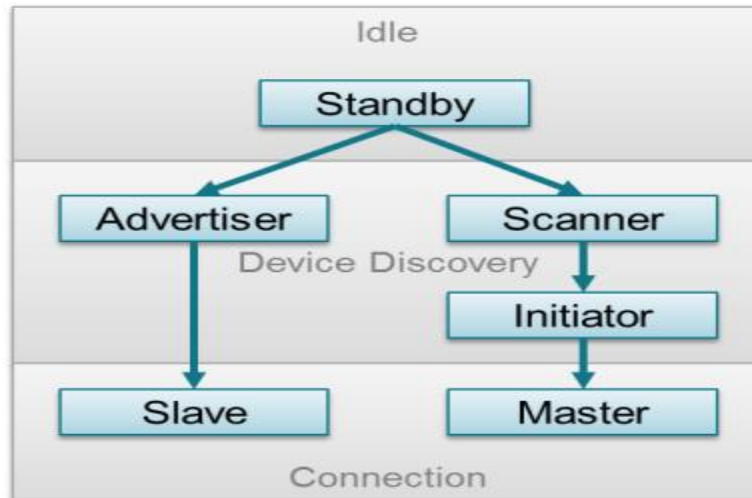

Figure 28: GAP State Diagram [39, reprinted with permission from TI]

In the Bluetooth connection process, the device (CC2650) will be in the standby state until a connection is to be created. This connection requires the advertiser and scanner to work together. The advertiser is on the CC2650 and it is sending out data to let other devices know that it is a connectable device. With the advertising being out there it allows for other devices to recognize it using the scanner listed in the figure above, the scanning device can see the advertising device and if it wants to connect to it then it sends a scan request. If the advertiser sends a scan response, then the scanning device is aware of it and can from there initiate a connection with the advertising device. Then the initiator comes into play, the initiator specifies an address of a device it wants to connect with, in our case the advertiser, then if an advertisement coming from the specified address is received the initiator initiates a connection with the advertising device. Once connected, a slave/master set up is formed with the initiator being the master and the advertiser being the slave.

Within the connection of the two Bluetooth compatible devices there are a few parameters that allow the connection to occur. These parameters include connection interval and slave latency both of which need to be kept in mind during the programming process. These will be talked about in further detail below.

Connection Interval:

When using BLE (Bluetooth Low Energy) connections such as the ones created through the use of the CC2650, when two devices send or receive packages amongst one another it is called a “connection event”. For these connection events to occur the use of frequency hopping is incorporated, meaning that the two devices can only send or receive data from each other at a specific time and frequency, this is seen in the figure below. “The connection interval is the amount of time between two connection events [39, reprinted with permission from TI].” The connection interval can range anywhere from 7.5ms to 4.0s. This is

important because connection intervals affect the power consumption of a device and depending on the application, a project may need different connection intervals. An example of a connection event and its interval can be seen in the Figure 29 below.

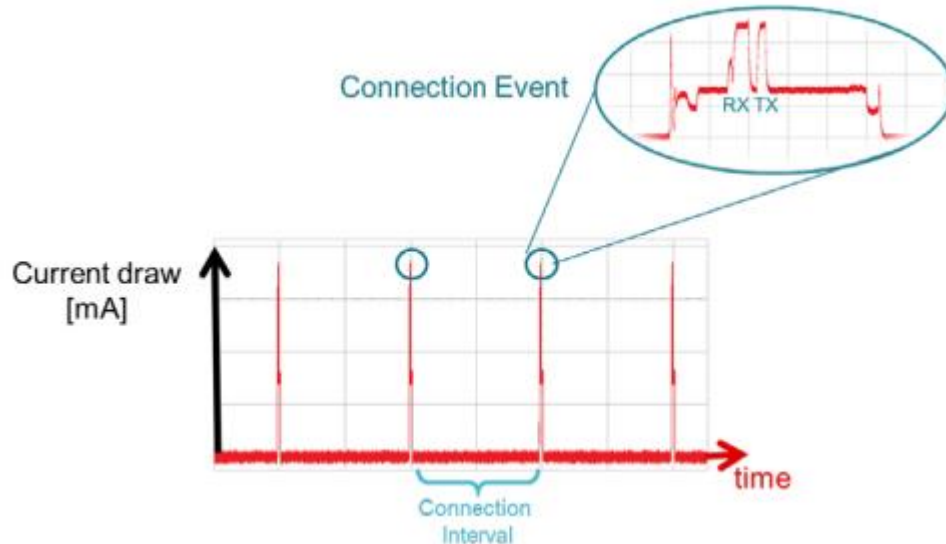

Figure 29: Connection Event and Interval [39, reprinted with permission from TI]

Slave Latency:

Slave latency is the ability for the slave device to skip a number of connection events. If the peripheral (slave) does not have any data to send to the master, then it can choose to skip the connection event. By skipping the event the slave can stay in sleep mode and ultimately end up lessening the overall power consumption of the system. That being said there is a slave latency parameter that is set and if the peripheral skips more than a set amount of connection events then the system will fail. This provides flexibility and can help to determine the overall power consumption in a system. For our purposes, we will have to decide how we choose to use this parameter within the programming of the Bluetooth notification system.

Considerations for Connection Parameters:

Now that we know and understand some of the connections we can see the effects they can have on the overall system. Like most parameters there are benefits and drawbacks to be considered when deciding how to use them. Below is a list from TI explaining what happens based on how connection intervals and slave latencies are used.

Reducing the connection interval does as follows:

- Increases the power consumption for both devices
- Increases the throughput in both directions
- Reduces the time for sending data in either direction

Increasing the connection interval does as follows:

- Reduces the power consumption for both devices
- Reduces the throughput in both directions
- Increases the time for sending data in either direction

Reducing the slave latency (or setting it to zero) does as follows:

- Increases the power consumption for the peripheral device
- Reduces the time for the peripheral device to receive the data sent from a central device

Increasing the slave latency does as follows:

- Reduces power consumption for the peripheral during periods when the peripheral has no data to send to the central device
- Increases the time for the peripheral device to receive the data sent from the central device [39]

These tradeoffs are things that must be considered when programming the sending and receiving of Bluetooth notifications.

5.2.2.2.2 LED (Visual) Notification System

The second aspect of the overall notification system is a visual alert using LED's. This portion will execute at the same time as the Bluetooth module's push notification. When the proper amount of time in between pills has occurred, then the LED's will begin to blink in an alternating fashion signifying that the pill is ready. This will be set to occur simultaneously with the Bluetooth aspect of the notification, that being said in most cases the LED lights will be the first sign in the system. This is due to the Bluetooth module having delay factors that the LED's wont experience because they will be directly connected to the CC2650 and the Bluetooth push notification will have to be sent out to and received by a smart phone, which will most likely result in network delay in the actual receiving of the alert.

Programmatically the LED notification system will probably be one of the easiest features to program in the CC2650. Being that the flickering of these lights is in most cases the first thing you learn when exploring programming of an CC2650 microprocessor. The alert will be triggered the same way that the previous notification system is, when the Boolean variable representing that a pill is ready to be disbursed is true, then the lights begin to flicker. The plan is for the light(s) whether it be 1 or 2 to alternate between being on and off until the push button to dispense the pill has been pressed. Once that event has occurred the LED's will be off until the next round of notifications are to be sent.

5.2.2.2.3 Audible Notification System

The third and final portion of the overall notification system is the use of a piezo buzzer to produce an audible alert. This will be the final wave of the notification process. Whereas the previous two will be initiated simultaneously, this portion will occur ten minutes following the initial waves of the system. The audible

section will only occur if the pill hasn't been disbursed within ten minutes of it being available. If the pill is taken on time then this audible alert won't occur at all.

This portion of the program will use a piezo buzzer. The buzzer will be attached to the CC2650. The execution of this portion programmatically will be different than that of the previous two sections. Whereas the previous two used the Boolean variable previously described, this section will use a separate timer variable. The timer will be started when the variable representing whether the pill is ready becomes true. Once this occurs if the pill does not get dispensed via the push button before the timer hits the ten minute mark, then the piezo buzzer will be activated and the audible notification will occur. This alert will go on for a few minutes or until the pill has been dispensed. This is the final portion of the notification system. In theory the three part system should be sufficient in notifying the user to take their pill.

5.2.2.3 Security Alert System (Records when the case is opened)

This feature is used to record anytime the casing of the pill dispenser is opened. For the ideal use case the only person who should be opening the case would be the pharmacist who is refilling the prescription. This feature is used to detect foul play, meaning to detect anytime the case has been opened when it shouldn't have. This is used as a precaution to try to lessen the likelihood of the casing being opened and the pills being removed which ultimately is an attempt to avoid the drug abuse and or overdose.

The way this will be implemented mechanism wise is with the use of a magnetic sensor. The magnetic sensor should go off anytime the case is opened. Therefore, within the code we must have a way of determining when the sensor goes off. When the case is opened there will be a change in voltage. The sensor will feed data to the Analog-to-digital converter which will in turn transmit to a GPIO on the board, which will tell the Medlock that it has been opened. Whenever the case is opened a time stamp will be created using code to implement a real-time clock. Every time the magnetic sensor is triggered then that time is fed into an array. We will have multiple functions set up for use in the security system. These will be explained below.

There should be three functions pertaining to the security system. The first function being the one described above, in which whenever the magnetic sensor is triggered a time stamp is inserted into an array. This function will serve to record all the times in which the Medlock has been opened. The second function will be one that prints the array that was made previously. By creating an easy print function, a person, ideally the pharmacist, can identify the times it has been opened and see if the case was ever opened at a time that it was not supposed to be. The last function would be to clear the first element in the array when the array length reaches more than 10. When programming in C as well as on a

microprocessor there is a limited amount of storage so having an array filled with hundreds of time stamps isn't a good thing. Therefore, there needs to be a function to clear the array and free up the memory. While the memory needs to be freed up, we can't just put a push button to delete the entries in the array because then someone who opened the product improperly could delete the array in an attempt to cover up what they did. Overall this is how this security aspect will be implemented programmatically to increase the overall security and effectiveness of the Medlock product.

5.2.2.4 LCD Display

The main purpose of the LCD display is to show the information of the patient as well as the information about the medication. The display will mimic what a common prescription bottle label does today, that being showing the first and last name of the patient, the type of medication, the dosage for the medication, and how to correctly take the medication. The LCD display will easily be able to show all of the listed data in order to minimize confusion for the patient.

In order to successfully display letters, numbers, and other symbols on the LCD display, the data that will be displayed must be written to the appropriate addresses and memory. This will allow the program to access the correct data and activate the correct pins in order to display the inputted data. After the data has been correctly written and stored in the microcontroller, the timing and voltage signals must be configured. Every LCD display has a voltage range that it can operate in, in order for our display to work properly, the voltage must never exceed the operation range, and if the voltage does exceed the range the display could malfunction and possibly break. The timing must be configured in order for the user of the device to see the data to be displayed. The timing must be faster than what the human eye can interoperate in order to seem as if the data being displayed was constant and not flashing. If the timing is incorrect it will seem as if the data on the display is blinking or flashing, this could cause problems and inconvenience the user.

The next aspect of the LCD display that must be interoperated is the LCD memory map. Within the memory space of our microcontroller will be allocated memory spaces that will be used for the LCD display. A LCD display contains common pins as well as segment pins, in order for data to be presented on the display, the LCD display must be time multiplexed with certain display elements that turn on for a given period of time. As said above, the LCD must be scanned at a rate that is faster than the eye can see in order to seem as of the data being displayed is continuous and not flickering. For information to be displayed on the LCD display a one must be written to the correct address location. Writing a one to a specific address will display the element, a letter or number, on the corresponding section of the LCD display.

Next to consider is the bit ordering of the display. Each symbol is composed of seven segments to create numbers and letters, these segments are time multiplexed to display the appropriate symbol. Multiple segments are turned on and off to represent a certain symbol. The scan rate of the LCD display must be determined as well as which of the seven segments must be turned on in order to successfully display a symbol on the LCD. However, before anything can be displayed on the LCD, the power and bias voltages must be applied correctly to the LCD display. To do this, various configuration bits are set in the LCD display voltage control register. If the LCD display is being powered by an internal source, like in our device, then all external sources are ignored and disabled, this means that a zero is written to the corresponding register. Next specific registers must be used to indicate to the microcontroller how many LCD memory addresses must be reserved by the microcontroller. Followed by configuring the amount of memory addresses needed is a register used to configure the clock frequency that turns on the LCD display. Setting the clock frequency will allow for the LCD display to actually display data as well as turn the LCD display off and display no data. These are the basic steps that need to be taken in order to successfully display data on a LCD display.

5.2.2.5 Servo Motor

The purpose of the servo motor is to serve as a medication dispensing component. The servo motor will be modified with a small plunger that will push one pill out of the pill holder at a time. By using a small modified servo motor, we will be able to accurately dispense one pill at a time with minimal error, in doing so will help the device reach its goal of helping stop opioid addiction.

There are a few components to the servo motor that require attention when trying to interface the motor with a microcontroller, those being the ground wire, the power wire, and the signal wire. The ground wire will connect to the controller's ground, the power wire will connect to the controller's power supply, and the signal wire connects to one of the controller's GPIO pins with some sort of buffer between the pin and the signal wire, in most cases this is a resistor. Those are the three basic components of a servo motor that require attention when interfacing the motor with a microcontroller.

Unlike interfacing a servo motor with a microcontroller, programming the motor is a little bit more difficult. In order for a servo motor to work correctly it must receive pulses of electricity at a given frequency; typically, these pulses come from hardware PWM. A common frequency for a servo motor like the one that we will be using is 50 Hz and a common clock speed is 1MHz since the pulses that the motor will be receiving will be around one and a half milliseconds.

To set up a code that tells the servo motor what to do and when to do it, setting up macros is the first step. Typical macros in a code such as this would include the MCU clock, PWM frequency, servo motor steps, minimum duty cycle, and

maximum duty cycle. Inside the main function there will be a couple variables that are designated to hold data based on how much the motor needs to move and when the motor needs to move. The next step is to make and fill out a look-up table, this is done by using a simple for loop and the variables mentioned above. After the look-up table is defined and filled up the PWM must be setup, this process includes first disabling the watchdog timer. Once the timer is disabled the TACCTL1 is set or reset depending on the situation and the sub main clock is updated. After the TACCTL1 and sub main clock are reset and updated the TACCR1 is updated with the proper duty cycle. After all of the above is complete the proper amount of pulses can be sent to the motor in order for the motor to make the correct movements. To get the motor to turn is quite simple, first a continuous loop is created; inside that loop is where the motor is told what degree the shaft must be. This is done by using the TACCR1 along with a certain amount of delay cycles, the delay cycles determine how long the motor shaft will take to reach the desired position. For our device, the motor will not need to make a full rotation, so one two angles will be sent to the motor from the continuous loop, those angles being the start and stop locations.

In order for the servo motor to know when to rotate a Boolean variable will be used. The Boolean variable will change depending on the real-time clock in the microcontroller. The continuous loop will be inside of an if statement, the loop will only execute when the if statement is true, which is when the Boolean variable is true. The Boolean variable will only be true within specific times and if a push button is pushed within the allotted time. By implemented a code as discussed, the servo motor will be able to successfully and precisely dispense a pill at the correct times.

5.2.3 Algorithm Description

In this section, we will go through our overall algorithm description. What this entails is a breakdown of each function which we plan to use within the program as a whole.

5.2.3.1 Pill Dispenser Functions

The purpose of this function is to properly dispense the pill on time.

- START
- Pass in Timer variable and Boolean variable for dispensing availability.
- Timer starts at 0, Boolean starts as False.
- When Timer hits allotted time between pills, the Boolean changes to true.
- When the push button is pressed the Servo Motor function is called
- The pill is then dispensed.
- Once pill is dispensed a variable counting the number of pills left is decremented.

- If the pill counting variable hits 0 then an alert is sent signifying the need for a refill.
- When button is pushed Timer resets to 0 and Boolean resets to false.
- END

5.2.3.2 Notification System Functions

The purpose of these functions is to notify the user as to when the pill is ready to be dispensed.

The first function is for the Bluetooth module notifications.

- START
- The timer variable and Boolean variable are passed into the function.
- When the timer hits the allotted time, the Boolean is switched to true.
- The Bluetooth module sends a push notification to the connected device.
- END

The second function is to for the visual alerts via LED.

- Start
- The timer variable and Boolean variable are passed into the function.
- When the timer hits the allotted time, the Boolean is switched to true.
- The LED's are then triggered.
- They will alternate between off and on using interrupts.
- Once the pill is disbursed the LED's will turn off.
- END

The final function is for the auditory notification system.

- START
- The timer variable and Boolean are passed into the function
- There is an additional timing variable introduced for this function, it starts at 0.
- When the timer hits the allotted time, the Boolean is switched to true, the new timer will then start counting.
- When the second timer hits ten minutes the Piezo buzzer will go off.
- The buzzer will continue to go off for 5 minutes or until the pill is dispensed.
- END

5.2.3.3 Security Notification Functions

The purpose of these functions is to register when the case is open, print those values, and clear those values.

The first function will store the times when the magnetic sensor gives of a specific voltage, meaning the case has been opened.

- START
- Create an array, and implement a real-time clock.
- The real-time clock is always running.

- Whenever the case is open the magnetic sensor will have a change in voltage.
- This sends data through the ADC.
- The ADC then notifies a GPIO.
- Whenever the GPIO receives the notification that the case has been opened the time listed on the real-time clock will be recorded into the array.
- END

The second function will print the values within the array.

- START
- This function will have the array passed into it.
- There will be a for loop to iterate through the array.
- Each iteration will print a value in the array.
- END

The final function will clear the values from the array.

- START
- This function will have the array passed into it.
- If array becomes larger than 10, the oldest entry is deleted.
- There will be a for loop to iterate through the first element in the array.
- Each iteration will delete a value in the array.
- END

5.2.3.4 LCD Display

The purpose of these functions is to produce a display on the LCD screen.

The first function configures the memory map.

- START
- Memory is allocated in the memory space of the microprocessor.
- The LCD display is time multiplexed with specific display elements for a given period of time.
- The LCD is scanned at a rate faster than the eye can see frequency variables.
- END

The second function configures the bit ordering.

- START
- Segments are chosen to be either on or off based on being given either a 1 or 0 value.
- The symbol displayed will be determined by these segments.
- The power and bias voltage are set via configuration bits in the LCD voltage control register.
- Set the register controlling external sources to 0 since Medlock uses only internal sources.
- LCD memory addresses are reserved.

- A register is used to configure the frequency of the clock to display the LCD's.
- END

5.2.3.5 Servo Motors Functions

The purpose of these functions is to control the servo motors which will ultimately dispense the pill.

- START
- Interrupts are implemented to help control this.
- Variables are set to control things such as the angle, delay, and how much it needs to rotate each revolution.
- The push button is attached to the servo motor through code.
- When the push button is pressed the servo motor rotates.
- This activates the plunger.
- The plunger then pops the pill out.
- The plunger is then reset.
- END

5.2.4 Pill Disbursal Flow Chart

Figure 30 below shows the actions, variables, and procedures that come into play when it comes to the software process of identifying when a pill is ready and ultimately dispensing the pill.

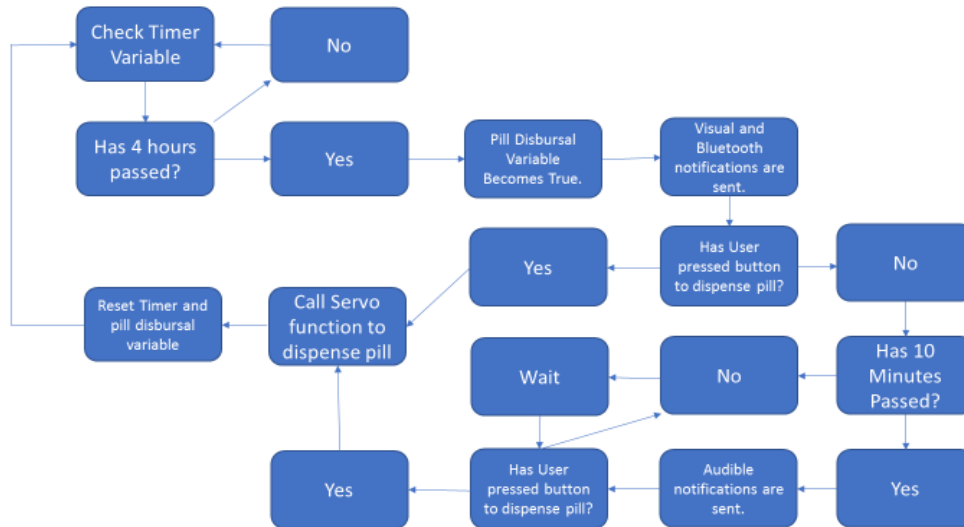

Figure 30: Pill Disbursal Flow Chart

With the pill dispensing process being the most integrated process, as well as the procedure with the most possible options and outcomes it seemed to just lend

itself to a flow chart. The above figure identifies all the possibilities within the pill dispensing and related functions. As can be seen the procedure for the disbursement of a pill calls upon several different functions and portions of software. When the pill is ready to be disbursed it calls upon the first two notification functions, Bluetooth and LED display, if the pill still has not been disbursed following ten minutes then we call upon the final notification function, the audio alert. Once the push button is actually clicked and the user is choosing to dispense their pill then we call upon the servo motor function which physically disburses the pill to the user. With this being the most integrated of the software system, it also is the most complicated therefore a flow chart is necessary to not just help the user understand but to also serve as an additional reference for the programmer as well.

5.2.5 Software Requirements Traceability Matrix

A requirements traceability matrix is used to identify the entire necessary requirement for a design. In this case the matrix will identify each different functional and non-functional requirement that the software should satisfy. Along with the requirement number and description comes the design reference section which identifies which module or functions are will be needed to accomplish that requirement, this can be seen in the table below. Table 10 below shows this.

Disclaimer: This matrix will only show software requirements

Requirement ID	Requirement Description	Design Reference
1	LCD display that shows patients name, type of medicine, dosage amount, and time in between dosages.	LCD_ConfigMemoryMap and LCD_ConfigBitOrder Functions.
2	Pill is released when the proper time between dosages has passed and button is pushed.	Pill Disbursal and Servo Motor Functions.
3	Bluetooth push notification is send when pill is ready.	Bluetooth Notification Function.
4	Visual notification that pill is ready occurs using LED's and ends when pill is dispensed.	Visual Alert Function.
5	Audible alert that pill is ready 10 minutes following Bluetooth and visual notifications if pill has yet to be disbursed.	Audible Alert Function.
6	If the pill disbursal button is not disbursed on time, the software starts the new disbursal time when	Pill Disbursal and Servo Motor Functions.

	pill is disbursed.	
7	Software can determine when a refill is needed based on number of pill disbursements.	Pill Disbursal Function.
8	Magnetic sensor logs the time whenever the case is opened.	Magnetic Sensor Case Open and Print Functions.
9	Make sure only the proper number of pills is dispensed at a time.	Pill Disbursal Function.
10	Ability to display number of times the case has been opened and at what time each opening occurred.	Magnetic Sensor Case Open and Print Functions.
11	Software clears earliest opening time once total times exceeds 10.	Magnetic Sensor Case Open and Clear Functions.

Table 10: Software Requirements Traceability Matrix

The table above is in many ways helpful in the software design process. It first off allows the developers to identify all of the requirements that the software must suffice. With that said it also takes it one step further in linking the requirements to the various planned functions within the planning of the overall system design. This allows for an easy to look at set of guidelines for the programmers and shows some of the coupling and dependencies within the software in a more graphical way.

The Software Requirements Traceability Matrix not only aids the developers in the visualization of the system but also further down the line in the testing. With each requirement drawn out and labeled with dependencies the creation of good test cases is streamlined. When you are able to see exactly what needs to be tested and the specific functions that will have an effect on the testing process then making test cases that sufficiently show whether or not the feature is working as planned is far simpler.

5.2.6 Class Diagram

The use of a class diagram is common practice across the software engineering industry. A class diagram does many different things to help the programmers and users further understand how the system works. A class diagram first off creates a function for each of the different portions of the code. Under each of the functions there is a list of the variables that the function will use as well as the other functions that it will need to call to complete the purpose it serves. On top of that each variable and other function used can be denoted as public, private, etc. within the diagram. If there is a + sign next to any of the variables or other functions then that piece of code is public. On the other hand, if there is a minus sign in front then that means the section of code is private. Any connection between functions means that they either interact with each other or access

information within each other. Our class diagram is shown in the Figure 31 below.

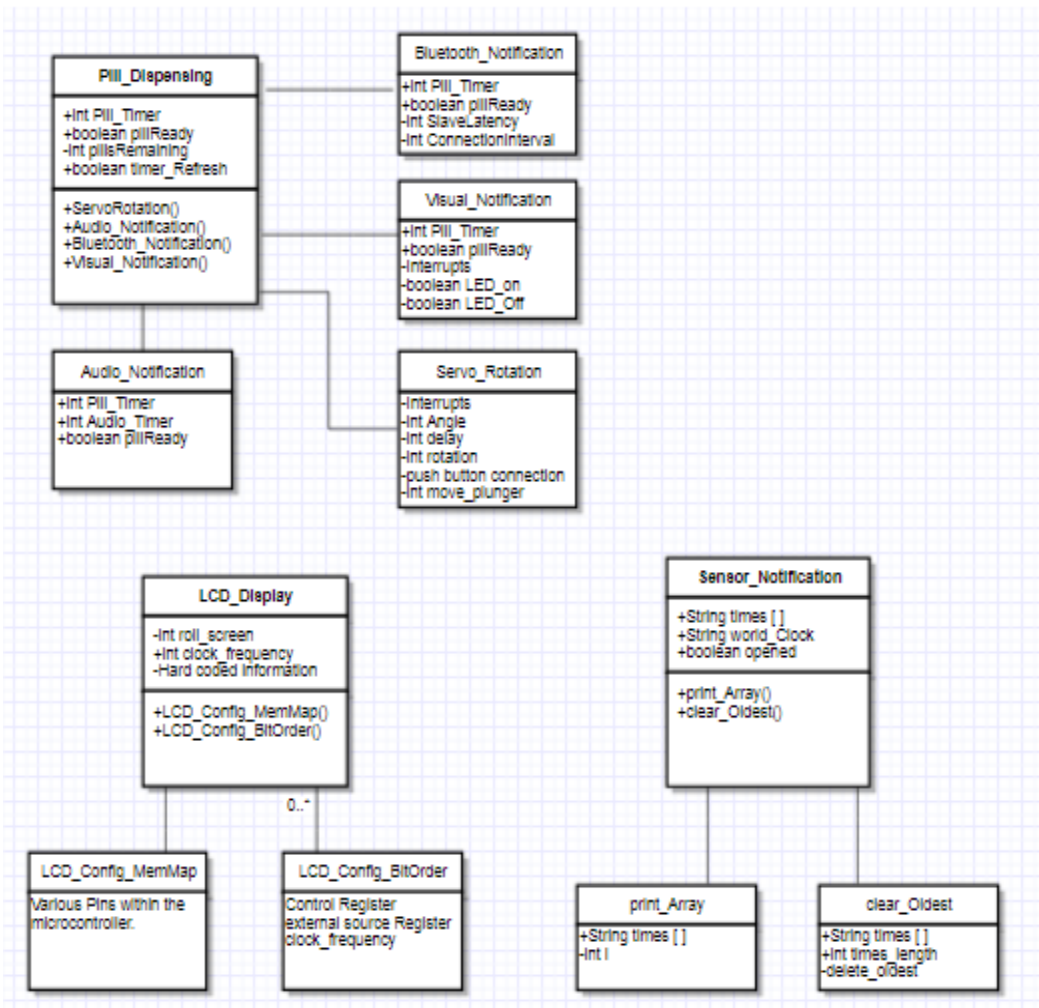

Figure 31: Software Class Diagram

For our purpose, a class diagram that can be seen in the figure above was created to help the programmers keep track of what needs to be done and what interactions must be achieved. This diagram will act as a guideline along with the previously created function outlines and requirements traceability matrix. That being said the overall construction of the software as well as the class diagram itself is subject to further change based on what the programmers may deem fit in the future of this project.

6. Prototype Construction and Coding

The following chapter will discuss the prototyping stage of Medlock.

6.1 Printed Circuit Board

A printed circuit board (PCB) is the surface which houses many electronic components which are organized into circuits that perform a single or series of functions. They can be found in many electronic appliances from dishwashers, cars, and even handheld devices such as a cell phone or pill dispensary. PCBs can come in various types such as single-sided, double-sided, and multi-layered boards. Depending on how complex the circuit design may become, the option of having more than one side to work with would be ideal. This decision will, of course, be more solidified once breadboard testing is performed making knowledge about fabricating these different types of PCBs prudent.

6.1.1 PCB Design

FR-4 proves to be versatile and a safer option since it can withstand high stresses especially when considering the temperatures it can reach when soldering parts and under normal operation. The FR-4 is bound together then dipped in an epoxy resin to reinforce and strengthen the core of the PCB in which it provides an electrical isolation between the copper layers which can be added to one side or both the top and bottom of the laminate. If a multilayer PCB were being created, the copper foiling would alternate in layering with the FR-4 substrate. The general thickness of FR-4 is around 0.2 mm so for a more solid separation between copper and substrate layers means adding a multitude of them.

As for the copper layering as mentioned earlier, the number of copper layers there are denotes the classification of a PCB. This means a single, double, or multilayered PCB just refers to how many copper layers there are. It is a foil that is defaulted to the weight of 1.2 oz which provides enough conduction to connect between components. Any heavier and the price would increase however the issue of heat sinking and heat management, especially when dealing with medications, would decrease with a thicker copper layout [40 reprinted with permission from Epectec]. Not only would the heat be better handled but the amount of current carried from component to component would be increased leading to fast communication and processing [41, reprinted with permission from OmniCircuitBoards]. When creating paths for the parts to communicate with each other, holes are drilled into the board for the pin connections. Inside the walls of the drilled holes are plated with copper to ensure conduction. It should be noted, however, that sometimes when a PCB is professionally manufactured, the copper has a mixture of tin, lead and/or another metal to slow the process of oxidation and makes soldering easier to do [42, reprinted with permission from

Robotroom]. Lead is a metal mixture choice though in terms of safety when soldering, it's best to opt out of using that metal.

The next layer which protects the copper from oxidation is the solder mask. This is what creates the characteristic green color of PCBs though companies are able change the colors upon request or just as a company standard. Aside from the coloring, provides spaces for soldering as well as protecting the circuitry from forming shorts nearby soldering pads, corrosion, and makes it easier to solder quickly by hand and especially by mass-produced boards via wave soldering which is large-scale soldering process.

Over this, the silkscreen is placed to provide identification markings for pins, components, the PCB, company logos, warnings, and other markups needed to further label the board being used. The point is to make the board easier to understand for human use so clarifying the aspects of the PCB is crucial to avoiding misconnections and possibly damaging the components if misused. The manufacturer's labeling is also found written on this layering in places where no markups are needed and/or inessential areas. The ink used is non-conductive and usually white but as with the solder mask coloring, this can be changed [43, reprinted with permission from OmniCircuitBoards]. There are also options to have a silkscreen under the solder mask though, as always with the addition of more materials, the cost will rise.

Once the PCB is created, the next step is to fill components onto or through the surface. Depending on the part, either hand soldering or stenciling is done to attach the parts to the board. Through hole parts are better hand soldering to the PCB due to the leads being large enough to handle. This process needs great care since the components are still relatively small despite being large enough to handle with hands. Poor soldering techniques could lead to misalignments, excess flux, shorted components, cracked joints, and overall damage to the PCB and surrounding components. The other technique used is stenciling which is how surface mount parts are attached. First, the PCB must be held firmly in place by an ESD-safe frame taped down to prevent movement around of the board, thus avoiding smearing and possible shorts. The medium used to solder is simply soldering paste, which comes in a few types, but generally it's applied evenly over the edge of a paint scraper. Once the stencil is stable over the pin layout, the paint scraper is ran over the slots in the stencil until an even amount of paste is smeared over the top, with more applied as needed. Then, the scraper is moved across the stencil yet again but at a steeper angle towards 90 degrees to wipe off the excess.

6.1.2 PCB Software

The beginning step to creating a truly unique PCB is with a schematic of the circuits desired. This stage establishes the map of the design to be captured by an electronic design automation (EDA) program. . They create or turn schematics already designed into PCB layouts using the Gerber standard of creating image

files of the copper layer, solder mask, and the sort using .gbr as the file extension for PCB fabrication companies to use. However, there are quite a few programs in the market to take advantage of. Since the PCB is essentially the skeleton of the device, choosing the right software is extremely important for robustness and control of the overall layout. Characteristics considered when researching programs were if they were simple enough for beginners to pick up yet able to perform tasks fit for a veteran meaning that. Due to the time constraint of the project as a whole, quickening the understanding of the software would benefit the progress of it. On that same thread, while it's desired for the program to be simple enough to pick up quickly, it should still have an adequate amount of useful features and the components specific to our device. In addition to this, the lower the price, the better in hopes that performance and accuracy is not sacrificed. Table 11 holds a list of programs investigated.

Software Program	Features	Price (\$)
DesignSpark	Unlimited layers	Free
EasyEDA	6 layers, no installation	Free
Ultiboard	64 layers	Free evaluation
Eagle	16 layers	Free (student edition)
KiCad	32 layers	Free

Table 11: PCB Software Comparisons

Each program has their own advantages and disadvantages. Ultiboard, being part of National Instruments, works directly with Multisim, a schematic program almost exclusively used at UCF so understanding how to use it wouldn't be too difficult. The library, on the other hand, isn't as wealthy in components as desired considering how the CC2650 family isn't available on this platform. Eagle is a well-known, powerful schematic and PCB layout program with an extensive library and customization tools. The unfortunate detail about Eagle is that, while it may have the predecessors to the MCU and hundreds of other TI components, it also does not have the CC2650 itself. EasyEDA seems to solve the problem the other two software packages have so recreating the MCU, and possibly making mistakes with the inputs and outputs of the pins, won't have to happen. More added benefits include no installation, a large library, and it uploads designs and schematics to their Cloud privately and for free. Its downside is how it requires a constant internet connection so there is no offline mode and the number of layers available is the least found among any other software package though the design of Medlock shouldn't be so extensive that it requires more than 6 layers of the PCB. To compromise, both EasyEDA and Eagle can be used since EasyEDA

can import designs from Eagle. Specifically for the program Eagle, it uses the Gerber standard but its file extension is .brd instead of .gbr. This turns out to not be much of an issue since Eagle is widely used among hobbyists as well as smaller firms and can be accepted by fabrication companies.

6.1.3 PCB Design Techniques

The PCB design was based around the Bluetooth antenna, the USB connection, and the regulators. The power and data coming in through the USB demanded that trace widths need to be considered. The USB also had to have access to an edge of the board so the connection wouldn't interfere with the edge of the board. The Bluetooth antenna had to be isolated from the ground plane to ensure integrity of the signal. This meant it required an isolated corner to ensure easy connection to ground for other components. The regulators will be handling the power and need to be considered as heat sources. The board will be part of a portable device kept close to the user and additional heat concerns need to be considered. To handle this the regulators will need some spacing to avoid concentrating the heat.

Manipulating Traces:

The equation for the resistance of traces is shown in Figure 32 below. Considering the board will be small for portability the resistance seen in traces is mostly negligible.

$$R = \frac{\text{resistivity} * \text{length}}{\text{thickness} * \text{width}} = \frac{\rho l}{A}$$

Figure 32: Equation Resistance of Traces

Separating Analog and Digital Circuitry:

Placement on the board matters in terms of noise reduction and signal interference. As a rule of thumb, digital and high-speed logic and components are to be placed close to the power supply then the slower parts, the furthest parts being the analog circuitry. Reason for this is due to when signals are received and transmitted, the process produces electrical noise which analog and slower circuitry are sensitive to, enough so that it disrupts their processes. Having a mismatched board with digital and analog circuits placed wherever convenient will inevitably slow down the device and possibly mix signals together which would confuse the system. Additionally, ribbons and cords arrangements should not overlay or cover the faster components otherwise their signals could be mixed in and be carried to the other parts.

Grounding:

Grounding a PCB is not as simplistic as doing so in a schematic program. When a trace is grounded somewhere, it needs to have a return path for the current which leads back to the power supply. Despite how some schematics are

designed, without a sort of grounding feature, the circuits would fail and quite miserably.

Avoiding Long/Many Loops:

When creating traces in-between parts, making sure that they aren't long as well as wound in many loops reduces the amount of inductance and resistance in the PCB. The same with issue happens with grounding: when high frequency loops are large, they would start to resonate through other components and distort the sensitive, low frequency signals [44, reprinted with permission from TI].

Furthermore, many loops with current running through, the magnetic field would increase in the device which is an application used for antennas but that is not the goal for the PCB of dispensary. Looking at the equation in Figure 33 below also shows that with an increase in inductance, so too would the voltage increase.

$$V = L \frac{di}{dt}$$

Figure 33: Equation Voltage in an inductor

6.1.4 Thermal Management

Thermal management becomes a very important concern when keeping temperatures as low as possible to not reach the medication's peak levels upon operation. The components inside have their own threshold to reach though the standard for electronics is generally more lenient than that of medication. Regardless, this can be regulated with the design, and perhaps usage, of the PCB.

The board will have to be relatively small and compact enough to stow inside a personal compartment meaning that with the limited amount of space, its ability to disperse heat is lower than a board larger in size. Adding a vent to the casing to prevent heat from trapping inside the device and to promote air circulation can aid in reducing the heat experienced within the device though using a heat sink is a more stable way of controlling the heat. Due to intense amounts of switching in ICs from millions to billions of transistors, the energy created to move those electrons dissipate into heat but since ICs are getting smaller and smaller, viable heat sinks need to be made. Some use metal on the underside of the packaging to dissipate on the PCB or just use the packaging itself as the heat sink though the efficiency of that is questionable at best. As a solution, the heat sink can be placed around the component on the surface of the PCB for more efficient dissipation. Depending on the company, a device's datasheet could contain information on the guidelines to using the PCB as the heat sink.

The use of miniature fans placed inside the dispensary, as they are used for other devices such as desktop computers and power supplies, can be an option, but other factors when implementing a fan needs consideration. The supply

voltage of the fan might be higher than desired, causing a drain to the power source. Also, the power consumption required to run it may be high as well and could cause an excess amount of heat to the system than initially anticipated which would do more harm than good.

Another solution, which seems to be the best at maintaining a low temperature is the use of the CC2650 low-power mode. This allows for the device to only operate fully when interacting with the user, dispensing pills, or otherwise communicating then switching to a sleep-like state that runs only the basic processes for it to remain on until interfaced with again. This way, the ICs would only have to work when necessary and the temperature inside of the machine can be within the requirements of the medication prescribed. Furthermore, the battery life would extend since less power is used to operate.

6.2 Potential Concerns

When constructing any device, whether it's large or small, being aware of mishaps and preparing for them is extremely helpful. Keeping problems that could arise present to the task at hand will give reason to err on the side of caution ensuring that this project is completed in a timely and planned manner.

6.2.1 Hardware

Succinctly put, time is the greatest concern for the entire project. For hardware, shipping time will inhibit production time primarily because it serves as an interruption and possibly a setback if the parts were delayed for whatever reason. Lack of parts leads to no construction or testing which means the deadline is getting closer while hands are tied due to forced procrastination. There are three possible solutions to this issue, one being to order components as soon as possible but this could lead to miscalculated parts and more wasted time and money. The other more practical solution is to order more than just one part of each component. This is in the case that one major piece malfunctions regardless if it's the manufacturer or the user handling them. Buying these backups allows room for error and for if disasters or accidents happen.

Following the thought, mishandling the parts once in the possession of them is extremely important. Electrostatic discharge (ESD) is so much a prevalent problem that nearly every IC has an ESD circuit on every pin to prevent people from instantly frying their chips before having a chance to use them. This can very easily be avoided with the use of ESD or plastic tweezers when handling these delicate devices. Regardless of their own circuit protection, it would be in bad practice for an engineer in the field of electronics to carelessly handle such parts by placing them in a hand.

Another potential issue that can happen comes from stenciling. It was already mentioned in a previous section about how steep a price it is but the true problem

arises if it wasn't carried out with great care. Now, it's not the act of applying the solder paste but the act of creating the stencil when creating the PCB in the software used. If the vias, pins, holes, traces, anything isn't aligned properly, hundreds of dollars are immediately wasted along with a large amount of time. Time from both waiting for shipping and time from having to recheck everything once again. Taking several moments to go over the design and asking for help or advice when in doubt will save the project from stagnation and the members from much grief. Incorrect alignments could lead to shorting pins during the solder pasting phase, partial connections to the traces, and overall destruction of the IC, specifically the MCU for the dispensary.

6.3 Prototype Constraints

The creation of the PCB is time consuming when building a prototype completely from scratch and there is also the time taken for the order of it to be processed and shipped. A great deal of testing has to be done before the PCB is made to avoid spending more time to create another design of one and then wait for shipping. Only once satisfactory results are found from testing will the PCB be ordered which will save time and leave more room for the final testing phases.

The next step after receiving the empty board is to solder the individual pieces on. As simple as this sounds, the task can become tedious and quite difficult if one is not practiced in hand soldering. Also, as time goes on, components are getting smaller and smaller making hand soldering more of a challenge than it used to be. There is a high chance of making mistakes and accidentally shorting out pins due to incorrect practices with hand soldering so to minimize this step, doing the process of stenciling would be helpful. A major downfall to stenciling is the price of it ranging from \$100 to \$300 depending on where it's being made and the quality of the sheet being used which can be of a polyimide, stainless steel, vinyl sheets, etc.

6.4 Software Constraints

Throughout this report there have been several sections that discussed possible constraints within the project. In chapter 4 constraints for the general project were discussed and in the previous section possible constraints associated with the PCB design and implementation were explored. The identification and conquering of constraints can be the difference between whether a product works or not, therefore it is the students job to first identify the possible issues. In this section of the document possible constraints in the software design aspect of the project will be examined.

6.4.1 Static Programming of LCD Display

With the use of the CC2650 microprocessor from Texas Instruments comes a few limitations. We will be using Code Composer Studio along with the C

programming language for all the software development within this project. While these choices will be able to fulfill the requirements that we have laid out for this project, there comes a few compromises that need to be made. The first of which is that the LCD display will have to be statically or hard-coded.

While the TI microprocessors can communicate serially using software such as a hyperlink terminal there is no capability similar to scanf. Scanf is a command in the C language in which the user is prompted to input some value that is to be determined at run time. This means that the LCD display which, for the purpose of the Medlock project is to show the patients name, medication type, and dosage information, must be programmed prior to compiling. This simply means that the consumers information will have to be set during the programming process.

For many products this would be ineffective and damaging to the use of the project. In our case though the idea of the project is to replace the prescription pill bottles with a more secure solution. This being the case means that the product will in practice not need the LCD display to constantly change. Therefore, this constraint won't be as detrimental to the Medlock as it would be to others, since it isn't something that is going to be reused by many different people.

6.4.2 Unfamiliarity with the Bluetooth Programming

For the most part the programming of the Medlock system will be familiar. Everyone in the group has had multiple classes to learn the C language. We have all also had to take embedded systems which gives a basis for the programming of a microcontroller, more specifically one developed by Texas Instruments. Therefore, for the most part there is abundance of experience with the type of programming that is required for Medlock. This is not true when it comes to the programming of the Bluetooth module within the CC2650 and ultimately the sending of Bluetooth notifications.

This may prove to be the most time-consuming constraint for the software side of this project. There will have to be a concerted effort between the two computer engineering majors to find resources and ultimately gain an understanding of programming the Bluetooth notifications. With this issue comes a couple subproblems, these subproblems are because the notification coding process is different based on the operating system that they will be sent on. Therefore, two different processes will need to be taken based on whether the user has an iPhone or an Android device.

While this constraint may be the most difficult and time consuming within the software domain of the project, there are concrete steps that will be taken to overcome it. The first of which is to gather as much research as possible on the subject, which has already started to happen. There is a lot of documentation on the subject as well as forums which should prove to be helpful. Some of this

research can be seen in chapter 5 of this document. The next step in the process is to attempt the programming for each operating system. Then lastly use a launchpad for testing purposes until the PCB design and creation has been completed. Overall while this may prove to be a roadblock in the software design process, the familiarity of the development of the other components of the project should provide us with ample time to figure out the Bluetooth system implementation.

6.4.3 Software Version Control and Prototyping

This constraint is two different possible subproblems, the first of which is version control. When multiple software developers are working on a project together than the issue of version control is critical. This refers to the updating of the code and making sure that the others group members working on it have the updated code with understanding of what has been adjusted. For this constraint there are many strategies and tools that can be used. The first is the use of Git which is a repository system that can be used for the committing and updating of the Medlock program code. On top of this another important strategy that is beneficial for version control is the proper commenting of the code so that the other programmers know what has been changed and how it may affect the overall functionality of the final product. Lastly regression testing is very effective in the version control process. Regression testing is to test the previously working functionalities of the system whenever a major change is made to the code. This allows for programmers to make sure that in the process of fixing a problem or adding a new feature to the software they didn't break previously working portions. All of these strategies will be used to lessen the likelihood of a version control issue.

The second subproblem is software prototyping. For the most part the first round of programming and testing will be on a launchpad, giving the electrical engineers time for the PCB creation. Due to this any interaction with the PCB will be a bit later and a priority will be to make sure that the code has the same compatibility with the PCB as it does with the Launchpad. If all goes correctly then this shouldn't be an issue, but if the PCB is designed wrong then the quickest way to identify it will be through the testing. Therefore, the testing of the software on the PCB should be done as soon and as efficiently as possible.

Overall, we should be able to avoid or overcome these two constraints. Version control can be done properly with constant communication and the use of proper programming practices between the software designers. As for the prototyping, this constraint can first off be avoided by proper PCB design. If it does end up presenting itself then consistent and early testing can effectively identify it and give our group the ability to overcome the issue.

6.5 Mounting PCB and Components

Mounting the PCB and the components inside of the device casing is a very precise and delicate process. Many aspects must be considered about the PCB, battery pack, and other small components like the push buttons, LCD screen, and LED lights. In order for every component to fit correctly and work in its environment planning must be done and templates must be made to ensure correct fits. Making templates with paper or some other cheap and flexible product will allow for mistakes to be made and corrected from without costing more time and money, this strategy will be followed in mounting every component inside of the housing.

6.5.1 Mounting PCB

When mounting a PCB board inside of a housing there are typically two recommended approaches, these approaches being mounting through slots and mounting through standoffs with bolts to secure the board. These two methods are the most accepted methods when mounting a PCB board because both methods ensure that the board is secure inside the housing and will not move, possibly breaking the PCB board itself or other components inside of the housing.

The slot method utilizes physical slots that are both placed inside and secured to the casing or they are made as part of the casing. The slot must have a gap that is slightly wider than the PCB board thickness to allow for the board to slide in between the gap. Also, a symmetrical slot must be made on the exact opposite side of the housing to allow both edges of the PCB board to slide into the slots and be secure. Since the housing of our device will be 3D printed, we can design the housing to be printed with said slots so they are a physical part of the housing and cannot be removed. Figure 34 below shows a slot mount.



Figure 34: Slot Mount [45, reprinted with permission from Cryptomuseum]

There are two major cons in this method, the first being that if the PCB board has components on it that rise above the surface of the board and are close to the

edges of the board the slot method typically will not work. If any components are close to the edge of the PCB board the slots could potentially put pressure on the components causing failures. Also, if the components are too close to the slots in the housing they could cause the fit of the PCB board to not be snug, this would cause movement of the board inside of the housing and leaving the possibility of components breaking. The second is that in order to properly slide the PCB board into the casing, the casing is going to have to be printed as multiple pieces and secured together after the board has been mounted. This could cause structural integrity problems since the housing is not one piece, but more importantly if work needs to be done to the PCB board after it is mounted the housing has to be disassembled. Overall the slot method is a decent choice for simple PCB boards and few components.

Mounting the PCB on standoffs with bolts is basically putting the PCB board on stilts and bolting it down inside of the housing. The standoffs must be precisely placed and secured inside of the housing; each standoff must be placed inside of the housing so that when the PCB board is placed on them, every corner of the PCB board lines up with a standoff. On a typical four corner PCB board four standoffs and eight bolts are used. First the dimensions of the board are measured and a template is created to determine where the standoffs will be inside of the housing. Once the measurements are made and verified four holes are drilled into the housing at the exact spots that the standoffs will be, each standoff is then secured to the housing with a bolt. Next the PCB board is placed on top of the standoffs, the holes designed into the PCB board should line up with the standoff holes exactly and each corner of the PCB board is then secured into place with a bolt. Bolting the board down inside of the housing will ensure that the board does not move in any fashion and will not cause any components to break inside the casing. This method of mounting works very well with PCB boards because in some cases when the board is making a lot of computations and the components on the board heat up, the method allows for proper air circulations above and below the board. Putting the board on standoffs will also allow for more space inside of the housing to be utilized for other components. Components can be placed underneath the raised PCB board in order to maximize all of the space inside of the housing. Finally, because the board is bolted down but not permanently mounted, the bolts can be taken off if any work needs to be done to the PCB board after it has been installed inside of the device. This method allows for easy access to the PCB board when the housing is opened.

Both methods are very good choices for mounting a PCB board inside of a housing like our project calls for. However, the limitations with the slot method cause the standoff method to be a better choice. The standoff method will allow for better airflow for the PCB, will also allow for more utilization of the space inside of the housing, and will allow easier access to the PCB board once mounted. Since the device is being designed to be as small as possible, the more space that can be utilized the smaller the device can be, this is why the

standoff method is a better mounting method for a PCB board in our device's case.

6.5.2 Mounting the Battery Pack

Mounting the battery pack is very easy since the pack does not need to be oriented in any specific fashion; it just needs to fit inside of the housing. Since the battery can get hot when charging or a large amount of current is being drawn from it, the battery pack must have proper airflow to ensure that the pack does not overheat and potentially break. Since our housing will be 3D printed, the housing can be designed to have slight grooves where the battery will be mounted. Mounting the battery pack on a non-flat surface like parallel grooves will allow for air to travel underneath the battery pack at all times, cooling the battery. The best place for the battery pack to be mounted in our device would be under the PCB board considering that the PCB board will be mounted on standoffs. Having the battery pack close to the PCB board will allow the wire connecting the battery to the PCB board, powering the PCB board, to be minimized. Securing the battery pack to the housing can be done with a simple strap across the battery pack anchored to the housing or having a slot that the battery pack slides into. Securing the battery pack with a strap is a simple yet effective way to mount the pack. The strap could be easily tightened or loosened and would be able to fasten the battery to the housing with minimal movement from the battery. In case the battery needs to be replaced, the strap makes the battery pack easily accessible. Mounting the battery pack using the slot method is also a very good choice. Like the grooves mentioned before, the slots would be able to be 3D printed so that they are part of the housing. The slots would have to be the same width as the battery pack thickness; since the slots will be made from plastic they will have some flexibility, and since the battery pack is perfectly flat it should slide into place and be secured by the slots. As said before both methods would work very well, but because the device is being designed to be as simple as possible the strap method seems like a more feasible method. Using the strap would allow time to be saved while designing the housing due to the lack of having to make precise measurements and remove printing time when printing the housing. The strap method is the most simplistic choice to secure the battery into place inside of the device housing.

6.5.3 Mounting LCD Screen and Small Components

Mounting a LCD screen is another delicate and precise process because the LCD screen must fit snug in the mounting area and the screen must be visible to the user. The hole that is designed for the LCD screen to fit through must be perfect in order to not allow the LCD screen to move and possibly fall from its mount and break. The other components such as the LED lights and push buttons are mounted in a similar fashion as the LCD screen, meaning that the through holes designed for each component must be precisely made to ensure a snug fit for the component it was designed for.

The physical screen portion of the LCD screen measures sixteen characters across and four lines in width, this is 60-62 millimeters by 25-32 millimeters. In order to mount the LCD screen, the housing of the device must be designed to have an opening on the front of the device that is the same dimensions as only the LCD screen. With an opening the size of the screen, when put into place the LCD screen will be the only portion visible to the user, the circuitry controlling the LCD screen will be hidden on the inside of the housing. The LCD screen sits on a board that sends signals to the screen to display characters; this board is larger than the LCD screen. In order to successfully mount the screen, all of the data lines must be connected to the appropriate locations before the screen is mounted. The screen is then tested; once all tests are passed the screen can be installed. As said before the opening will only allow the LCD screen to fit though, the board the screen sits on will stop the screen from falling through the opening. The screen can then be permanently mounted using a glue or epoxy; the corners of the board will be glued to the inside of the device housing and given time to cure. Once cured the LCD screen will be permanently in place and in working order. The other method would be to bolt the screen to the housing by putting bolts through the board the screen sits on, but in our case, the housing will be thin and the bolts would be seen from the outside of the housing, creating an unattractive look as well as allowing the user to possibly tamper with the bolts. The best option to secure the LCD screen would be with the glue method.

The LED lights and push buttons are mounted in a very similar fashion to the LCD screen. Since these two components are very small the design of the device housing will not incorporate the small holes necessary to mount the LED and push buttons. Instead, once the device housing is printed a template will be made to determine where the LED and button will go. Once a proper template is created and accepted the proper sized holes will be drilled into the face of the housing. LED lights have a wider base than the bulb; the hole drilled would have to be big enough to fit the bulb through but small enough so the base does not go through. The push button also has a larger base than the button itself, so like the LED light, the hole drilled would have to be big enough to fit the button through but small enough to stop the base from coming through. Next step is to make all connections and ensure that all components are working properly before permanently mounting the components. Once it is confirmed that all components are working correctly they can be permanently mounted to the housing. Like the LCD screen, the LED light will utilize glue or epoxy to secure the bulb. The push button will use a legion plate and a nut that attach to the push button from the outside. The nut will be tightened from the outside of the device and the push button will be secured and mounted. Since the nut is on the outside of the device housing some epoxy or glue will be added to the inside of the housing around the edges of the push button base in order to minimize user tampering.

6.6 Internal Design of Device

The internal design of the device, meaning where all of the components are placed and secured, is a very important aspect of the device that cannot be overlooked. Each component location must be well thought out in order to utilize the given space inside of the device casing. To do so, a very simplistic schematic is drawn out roughly labeling where each component will be placed and anchored, this schematic does not have measurements because the size of the case will be determined by the size of the finished PCB. This schematic will determine where every component inside of the device will be placed and will ensure that every component fits in the device correctly.

In order to maximize the space inside of the device casing, we have decided to mount the PCB with the standoff method. Mounting the PCB with standoffs will elevate it inside of the device casing and allow for other components to be placed and secured underneath the board. In this case the component that will be mounted underneath the PCB on the standoffs will be the battery pack. The battery pack will be mounted close to the PCB in order to minimize the amount of wires supplying power from the battery pack to the PCB. The PCB will be mounted at the topmost portion of the device to allow for easy connections from PCB and other components like the LCD screen and LED lights. Having the PCB mounted on the standoffs will elevate the PCB towards the closing face of the device, minimizing the amount of wires necessary to connect the PCB to the showing components like the LCD screen and the LED lights. Since the battery pack will be mounted underneath of the PCB, the battery pack will also be very close to the top edge of the device casing. This is beneficial because this will allow for easy access to the battery pack for charging. A small port will be designed into the device casing to allow for a battery pack charging cable to fit in and charge the battery pack when necessary. The pill dispenser will be located at the other end of the device casing; a larger port will be designed into the face of the device casing in order to allow for pill dispensing. Next to the pill dispenser mechanism will be a servo motor; the motor will be fastened with a plunger and will push a single pill out at a given time. The schematic can be seen in figure 35 below to give a rough estimate of the position of each component in the interior of the device casing.

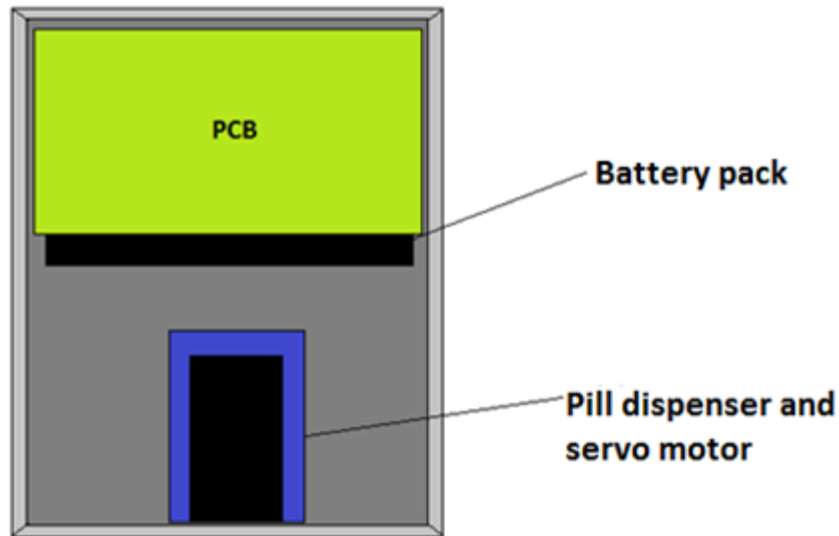

Figure 35: Inside of Casing

6.6.1 3D Printing Material

In order to prototype the device, a case will have to be made to house all of the electrical components. The best option for making the case is to 3D print it entirely. 3D printing the entire case will allow for precise measurements to be done, and will ensure that the case is designed exactly how it needs to be in order to fit all of the components accordingly. There are a couple options of material that can be 3D printed; the main classes are plastics, metals, and other materials like ceramic. These different classes all include subclasses that each has benefits and drawbacks.

6.6.1.1 Plastics

The first plastic is called nylon, or polyamide. This plastic is a flexible yet durable type of 3D printed plastic that is naturally white, making it easy to color. In order for the plastic to set correctly and hold its shape the minimum wall thickness must be at least 1mm, this is about 10 layers of the printed nylon plastic. The nylon is made from a powder, when refined into the plastic, the plastic forms long fibers that hold the plastic together. This allows for the given flexibility as well as the durability. Nylon is a good choice because it allows for precise printing to be done and it is cheap to use. The only drawback is that it may be time consuming to print because 10 layers must be printed for every wall in the device.

The next plastic is called ABS plastic. Like nylon this plastic is also flexible yet durable that can easily be printed through a 3D printer or used in injection molding. The pre printed plastic has a low melting point making it easy to 3D print. This plastic is often compared to legos, it has very similar durability and flexibility, meaning it is much more rigid but still has a little give. Like nylon ABS

printed plastic must have a wall thickness of 1mm at the minimum, the difference however is that only 3 layers need to be printed to meet this thickness. ABS plastic is another good choice because it is also very cheap to print with and allows for precise and relatively fast 3D printing.

The last main type of plastic that is used for 3D printing is called resin. Resin is a bit different from the other plastics, it is usually printed clear and not from a standard 3D printer. Instead of a printer head laying out molten plastic much like a 2D printer, resin printed uses a very different method. First, it should be known that resin is not cured from letting the plastic cool but rather with UV light. In order to print with resin a different type of printer is used, a robotic arm holding the base of the model is placed into a bath of resin, UV lights flash where the plastic needs to cure, the base is taken out of the bath and the cycle repeats. Like the other plastics, in order to hold its shape the wall thickness must be at least 1mm, resin needs 10 layers to meet that requirement. The benefits of using resin is that the most detail can be designed when using resin, however the drawbacks are that the printed plastic is delicate, printing time is usually quite long, and it is the most expensive plastic to print with.

6.6.1.2 Metals

The first type of metal is stainless steel. This is a very strong metal that has almost no flexibility. In order for the stainless steel to set properly the wall thickness, like all the other 3D printing materials, is a minimum of 1mm. To reach the 1mm wall thickness 5-6 layers of stainless steel must be printed. 3D Printing with metal is very different from printing with plastic. Instead of printing with molten metal, like printing with plastic, metal powder and glue is used. Drops of glue are put onto stainless steel powder; this binds the metallic powder and allows the object to hold its shape. To cure, the object is taken out of the printer when the printing has finished and delicately put in a safe place to cure over time. When the object has first finished printed it is basically an object composed entirely of wet powder, making it very fragile. The main benefit of printing with stainless steel is that it is an incredibly strong material that allows for relatively precise printing. The main drawback is that a specialty printer is needed and the cost is much higher than using plastic.

The other feasible metal to 3D print with is titanium. Titanium is a very light weight metal that is also the strongest of all the metals when it comes to 3D printing. In order for the metal to hold its shape and cure correctly the minimum wall thickness must be .2mm which is much thinner than all of the other materials so far. In order to reach the minimum wall thickness about 6 layers of titanium must be printed for each wall. 3D printing is very similar to printing with stainless steel, the titanium is loaded into the printer as a powder and instead of using glue, and a laser is used to sinter the powder together. This allows the final product object to be one piece, no after printing work is necessary. The benefit of using titanium to 3D print is that it is very lightweight, incredible precision can be

used in the printing process, and the material is the strongest of the metals, often being compared to machined parts. The drawback is that a specialty printer is needed to print titanium and the cost of printing is much higher than the other materials.

6.6.1.3 Other Material

The final type of material that can be 3D printed with is ceramic. Ceramic is a very rigid material but also pretty delicate, meaning that it can shatter if dropped. In order for the material to cure and hold its shape correctly the minimum wall thickness must be 3mm. To reach the minimum thickness of 3mm about 18 layers of ceramic must be applied to every wall in the object. Printing ceramic is very similar to printing stainless steel; a ceramic powder is used and sealed with porcelain, the steps are identical to that of printing stainless steel. The final step is to apply a glaze, or gloss, over the object; this makes it resist heat better and makes it food safe. Unfortunately for printing with ceramic is that there are more drawbacks than advantages. The main advantage is that the cost of material is very low, however the drawbacks are that the material is very delicate, precision printing is difficult, and printing is very time consuming.

6.6.1.4 The Material of Choice

The whole point of the casing of the device is to provide housing for the electrical components of the device; it is not designed to keep the user from being able to get inside of the device. That being said the best option to print the casing would be the ABS plastic. ABS plastic suits what our device needs because it is cost efficient and fairly durable. A standard 3D printer is used to print an object with ABS plastic and a fair amount of precision can be used in the design of the object. The material will not break if dropped and holds up to temperature changes. As said before, the device casing is not meant to be unbreakable, just to hold the components and provide a small barrier between the user and the medication on the inside of the device. ABS plastics will work the best out of all of the other available 3D printing materials because of these reasons.

6.6.2 3D Design of Device

In order to successfully 3D print the device casing to house the device components a 3D model must be made and rendered first. The 3D model will ensure that all of the dimensions of the casing are correct, if something appears incorrect in the design it can easily be fixed and not be costly. When considering 3D modeling software to design the device casing, the three most accepted programs are Blender, SketchUp, and SolidWorks. Each of these programs is widely used for 3D modeling and 3D printing each has their own benefits and drawbacks.

6.6.2.1 Blender

Blender is one of the most popular 3D modeling software because of its community. What is meant by that is users of Blender often share the resources that they use in projects. This makes it easier to design a device because chances are there is a good base resource that is available to use, this allows designers to not have to start from scratch if they choose. Another big advantage that Blender has is the forms and tutorials available on the internet. Since Blender is such popular software the experts of the software want to share some of their knowledge to other users to help get the newer users over the learning curve. When using Blender, a user has the incredible freedom to design what they want to design with the numerous tools that Blender provides. The main disadvantage for Blender is the drastic learning curve, making it difficult for new users/beginner users to understand the software and use it to its full potential.

6.6.2.2 SketchUp

SketchUp is another well received 3D modeling software for 3D printing. SketchUp is very user friendly software that allows the user to design 3D models easily. Numerous tools are offered that can make geometric objects as well as manipulate them; the tools are based on a point and click method that allows for total freedom from the user. Another big benefit for SketchUp is that it allows for prepping and sharing of 3D printable objects. This means, like blender, that if a user does not want to start from scratch they can use a readably accessibly model that has already been made and use that as a starting point for their design. SketchUp is a very powerful and user friendly software that is a great choice for 3D modeling and 3D printing.

6.6.2.3 SolidWorks

The final of the three modeling software is SolidWorks. SolidWorks is software that runs on Microsoft Windows and is a CAD, computer-aided design, and CAE, computer-aided engineering, program. SolidWorks makes use of a parametric feature-based approach; this means that the software uses constraints to determine parameters such as dimensions of an object. An advantage that SolidWorks has is its design intent, this allows the user to specify certain aspects of the designed object to remain static or change dynamically with the designed object. SolidWorks has features that allow the user to construct their 3D model initially from a 2D model with tools that SolidWorks provides, when transforming a 2D sketch to a 3D model, SolidWorks drives the geometry of the design with parametric nature of the software. SolidWorks is a very advanced 3D modeling software that has two major drawbacks, those being the price of the software and the heavy learning curve for beginner users.

7. Testing Plan

In the sections below, basic, yet detailed, frameworks of the testing phase of Medlock will be described. Procedures in both hardware and software testing will be provided to show the expected functions of the device for it to perform optimally. Features to be tested include:

- Battery recharge protection circuit
- Voltage regulators/converters and passive components
- Power supply
- Alarm system (i.e. buzzer, LED, LCD)
- Dispensing system (i.e. servo motor assessment and durability)
- Security system
- Software commands and responses

7.1 Hardware Testing

In the larger scope of operation, Medlock dispenses pills at an appointed time it's programmed to dispense however there are many more, and equally important, functions happening before, during, and after that instance. All of those functions need to be tested before they reach the hands of the consumer to ensure proper functionality and utmost safety. Complete analysis of the parts, circuitry, and components is just one part in satisfying both the market and engineering requirements. Needless to say, great care needs to be taken at this stage.

Examining the power supply circuit is crucial to the success of the design implementation. Without this testing, the risk of sending high surges of voltage and current into the components can not only damage and destroy them but can also, potentially lethally, harm anyone using the device. Conversely, this test can show if there is any power at all going through the correct parts it should be. Testing and troubleshooting will take place through the entirety of the project but each section will be independently examined before piecing it all together.

In the final designing stage of the device, once the PCB is assembled, a multimeter will be used to inspect the voltage across each connection with the aid of varying increasing voltages from a power supply. This will show if the correct values are being sent properly to the components i.e. a 5 V regulator sending 5 V across a component after calculating the voltage drop. The increasing voltage is to ensure a level of safety for the components in the case that connections went awry during the manufacturing process.

7.1.1 Hardware Specific Testing

Testing the performance of the integrated circuits being used in the dispensary can be done in a few manners but the ones focused on will be implemented

through a solderless breadboard and a breakout board. Since some components are surface mounted as opposed to through-hole, there would be no physically possible way to test the part without going through the process of creating a PCB just for that piece. Ideally, the use of breakout boards would be better for quality control in the event that the IC or areas around it malfunctions once fully connected. Finding out the errors beforehand would significantly reduce the cost of production in the grand scheme of the project. When looking for breakout boards, the type of packaging for the part is important to note. For the dispensary, the parts that aren't through-hole pieces have the QFN or VQFN packaging type which can be accommodated. A manufacturer of general purpose breakout boards, Schmartboard, has many pin configurations and pitches to their boards for only \$10 which beats out the over \$100 cost of producing even a simple PCB when stenciling is included. With this, legs can be attached to the board so it can be attached to a solderless breadboard for testing with the other components. If for whatever reason, the correct pin layout and/or pitch can't be found for the QFN, the alternative versions as through-hole parts can be found for breadboard testing.

Battery Recharge Protection Circuit:

Examining this will be ensure that the system is being properly charged without running the risk of overcharging or any leakage current. This step is a preventative measure for injuries with burns, fires, and/or deadly fumes which can arise from an overheated battery. Extra caution is needed for this since the medication within the product is meant to be ingested. Testing of this will be done by setting the protection up to a power supply and raising the current incrementally by 100 mA while keeping a steady voltage of around 4.2 V thus mimicking the same fashion the USB type-C will charge the system. If there is more current sent through the circuit than desired or if the battery is already close to full capacity, it should stop charging even while still connected.

Voltage Regulators and Converters:

As briefly mentioned above, the voltage across each voltage regulator within the entire circuit will be checked with a multimeter. Since the power coming from the battery will be a DC rating, measuring this won't be too complicated. The output should read correct, constant values when tested for high voltages.

Passive Components:

Despite the labeling, passive components such as resistors and capacitors are fairly notorious for having varying degrees of freedom in terms of their true value. To guarantee accuracy instead of taking the labeling at face value, each component will be checked by a multimeter before they are used.

7.1.2 Microcontroller Testing

Testing the functionality of the microcontroller lies in the software domain where section 7.2 will give more depth in the many purposes it will be programmed to fulfill. Testing the power input and output, however, lies in the hardware domain.

Here, it will tell how the other components such as the servo motors, LEDs, etc. should be configured. Extra precautions need to be taken in the case that too much or too little voltage or current is being fed into and out of the system.

Based on the impedance of each component, the equivalent in resistance will be connected to the pins of the MCU where they'll be used to measure the power consumption using a multimeter and a variable DC power supply. Because there is going to be a main voltage bus line, knowing the voltage output of each pin helps to accurately choose the appropriate regulator/switcher for the part. To avoid additional costs in materials, it will not be tested until it breaks but instead up to the MCU's voltage and current's min and max ratings according to the datasheet.

7.1.2.1 Power Supply Testing

Because there is medication in close proximity to the board, the temperature inside needs to be closely monitored. A standard telling of the temperature comes from how much energy is running through the system and to calculate this, one must understand what energy there is and where it's coming from.

When there is no switching involved, the static power consumption, P_S , in figure 36, is governed by how much voltage and current are supplied to the system.

$$P_S = V * I$$

Figure 36: Static Power Consumption Equation

This current is usually in the range from about 0.5 μA to 3.5 μA specifically for the CC2650 and represents the device in standby mode. Though as the clock rate increases and processes become more active, so too does the current, shown in figure 37 below.

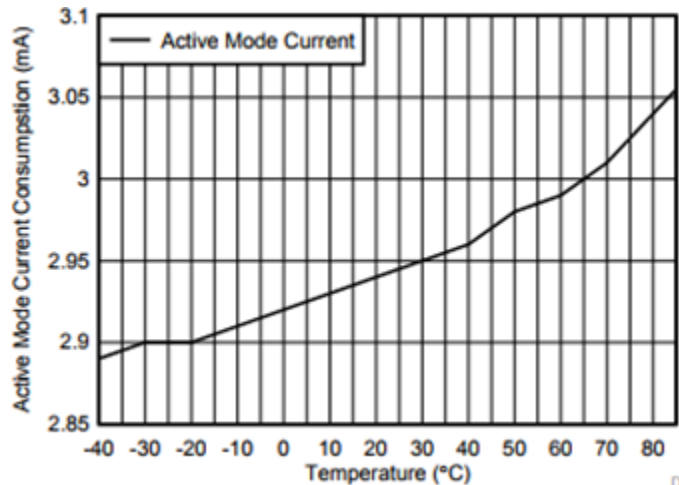

Figure 37: Active Mode Current vs Temperature [46, reprinted with permission from TI]

It's important to note that this reading is taken when there are no peripherals active and it is solely due to the MCU meaning that as soon as it's time to dispense a pill, the device will heat up quickly. With the frequency rising, keeping them steady requires high voltages and the power consumption changes to figure 38. Thankfully, the voltage input required for the CC2650 isn't very high, standing at 4.1 V as the maximum.

$$P_T = V^2 * C_{pd} * f_i * n$$

Figure 38: Power Consumption Equation

Where P_T is the transient power consumption, C_{pd} is the dynamic power-dissipation capacitance, f_i is the frequency of the input signal, and n is the number of bits switching, this displays the current running through the device compared to the capacitance during the switching of the transistors can be ignored. On top of this, when interacting with the different peripherals adds more power consumption because they all require carrying levels of frequencies and voltages. This is expressed in figure 39.

$$P_L = \Sigma(C_L * f_o) * V^2$$

Figure 39: Power Consumption Equation

Where P_L is the power consumption of the capacitive load, C_L is the load capacitance of the outputs, and f_o is the frequencies for the outputs. As can easily be seen, the voltage holds a heavy weight in both equations and shows even more importance as an increase in voltage means a decrease in current consumption, shown in figure 44 below.

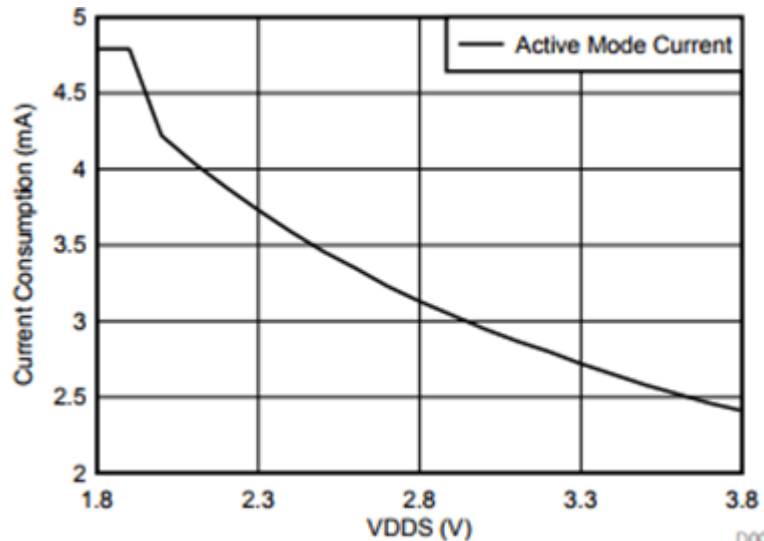

Figure 40: Current Consumption vs Supply Voltage [46, reprinted with permission from TI]

But depending on the loads and the frequencies required for them, this may also weigh heavily on the power consumption. With these equations in mind, getting the total dynamic power consumption is simply adding together both the transient and capacitive load power, shown in figure 41, and finding the total power consumed would be given by figure 41.

$$P_D = P_T + P_L$$

$$P_{total} = P_S + P_D$$

Figure 41: Dynamic Power Consumption Equations

7.1.3 Buzzer and LED Testing

Testing the buzzer and LED individually will be relatively simple with the use of a function generator. In a simple circuit using a resistor, a small voltage will be sent through using the square wave input option to test the volumes the buzzer can reach and the speed at which the LED will flash. Depending on the urgency, the duty cycle can be lowered or increased by changing the code going through the specified pins. Here, it's important to test whether the LED is bright and that the correct amount of voltage and current are being sent through it so it won't eventually blow out. Because the red and the white LEDs have varying voltages, each will be checked individually and adjusted accordingly. It will be tested at varying distances and determined if the flashing light is attention grabbing enough for someone to notice the device. Depending on the resistor and capacitor values, the intensity in brightness and volume can be controlled. In conjunction with the MCU, a simple command line can be written to send signals to switch the buzzer and LED on. Once verified, the application of them will be programmed to sound when needed and tweaked for accuracy.

7.1.4 Servo Motor and Security Sensor Testing

Without the aid of the microcontroller, the servo motor will be tested via a power supply with a rod to see the range of movement that can be used inside the device. The servo used comes with a slotted gear piece where the outer slots travel farther distances while the inner ones travel shorter distances. Adjusting the potentiometer inside the servo will show the range gradually so depending on how far the push rod needs to go, the placement will be modified. The radius of the gear is nearly negligible during this phase of the device and also for the specifications desired but for future devices like this, smaller gear options should be considered. During this stage, the guidance of the push rod is observed since the base of the rod is moving in a circular motion. The side of the rod making contact with the pill can potentially swing and push into the walls of the column the pills are housed so the addition of a track may or may not be included.

With the aid of the microcontroller, the servo motor would be tested for functionality. A signal will be sent to the servo telling it to turn on and rotate the gears atop 180 degrees, moving the push rod attached forward into the column of pills to slide the pill into the tray for the user to take. After the rod is fully extended forward, the servo would automatically be told to reset back to its original position. This function will be stress tested 100 times to ensure durability and success since it is one of the main functions of the dispensary. This system breaking would be a major detriment so finding out the bugs and faults early is more beneficial, especially since it realistically should last for months upon years instead of solely for the 15 minutes of the demonstration.

Here, the use of the button would come into play. Once the basic functionality of the servo is finished, a button placed between the MCU and the servo command line will control the distribution of the medication. If the pill is ready to be dispensed, pressing the button will allow the consumer to push out the pill for them to take. If the pill is not ready or it has already been dispensed, pushing the button in won't activate the servo as a preventative measure. If a pill is dispensed anyway, this means there is most likely an issue in the sequence of events in the program for dispersal which should be a quick fix. This test will run at least 50 times. Performing this guarantees that the system won't be confused if the button is repeatedly pressed in the case that it is being pushed in when stored in a clustered bag with other objects against it or if a child happens to lay their hands on it to start playing with it.

When testing the design of the sensor, the distance at which the emitter and receiver are placed will be measured for accuracy. The base amount of voltage it can work is 3.3 V so that will be the starting voltage but if more is needed somehow, the voltage can be increased up to 5 V. This will not be too likely since the emitter and receiver will have to be encased in a tight space so examining if the IR line of sight is broken should be extremely straightforward. While on the breadboard, a simple circuit with a 555 timer and a voltage comparator will be created with the aid of an LED. The purpose is to show whether the circuit can figure if the beam between the IR LED and photodiode has been broken and if so, the LED would turn on for an allotted amount of time depending on the values for the resistor and capacitor from certain pins on the timer. In the actual design, the only indication to the user that the beam has been broken will be shown on the LCD screen with the time and date the occurrence has happened.

Testing with the MCU will be a simple task since it only takes one GPIO pin. An object will be moved between it as described earlier to test for functionality. Once the IR sensor has been integrated into the PCB and installed inside the casing of the device, it will be opened numerous times in a variety of ways to test its sensitivity. First, it will be opened normally in the way the pharmacist would, unlocking the device and separating the packaging completely to access the contents inside while also checking to see if the date and time are accurate for when the device was opened. Then the package will be opened just slightly on

the opposite side of where the sensor is placed in an attempt at trying to break into the device. This is to assess if the sensor will still read that there is a large enough change in the system or if the opening was just small enough for someone to bypass that level of security to successfully take the medication.

7.1.6 LCD Testing

Testing the LCD screen will be done through the use of the microcontroller. The first test down will be adjusting the contrast on all of the pixels available for programming. This is done by using the potentiometer shown in chapter 5 and scaling it up or down depending on how well it can be seen. Ideally, the darker the pixels the better so the contrast between it and the backlighting will be at its maximum. This test also doubles as a visual inspection for dead or hot pixels, in case if a defective part was ordered. Knowing whether it's in good working condition as soon as possible allows the ordering process of a new one to happen quickly. In addition to this, a quality check will be performed by exposing it to different forms of light such as indoor lighting, sunlight, and the absence of it since the times for taking medication can happen at any time of day meaning that the screen needs to be seen at all times. The next examination for the LCD is to program a test script to check the response time and speed from the MCU to the LCD. Most of the LCD testing will be checking if the code is working properly in displaying the correct information and that the module is not cutting off letters or numbers. Specifically, when the device is opened, the IR sensor should feed data to the MCU in which the MCU writes data to the LCD to show the date and time the device was opened. Also, when the button is pressed, the LCD should display either the next time dispersal will happen or prompt the user that their medication has been properly released.

7.2 Software Testing

One of the cruxes of product development is the use of proper and effective testing processes. Any problems (or bugs) in the software as well as improper functionality of a feature can be identified through the testing process. The same goes for hardware, to see if a component is functioning properly testing is the quickest and in the majority of cases, most efficient route. This section of the document will examine and layout the design of the software testing plan that is to be incorporated for the Medlock system.

In software testing, there are many factors that must be identified before any testing can occur. These factors are in the most part different types of requirements that must be defined for how the system should work. These various requirement types include function, performance, reliability and maintainability, and integration testing. Each type serves a specific purpose in the effectiveness of the system as a whole and the understanding and testing of each is critical in the creation of a functioning, high-quality software product.

Function testing is testing to make sure the system works as stated in the system requirement developed by either the developers or sponsors. This type of testing will be important for our case, in that our grade relies on how well the actual product meets the requirements set forth. Overall function testing isn't particularly hard due to the fact that the tester will have a specific requirement that they will look at, perform the test case for, and determine whether or not it is working properly.

Performance testing is checking the non-functional requirements of a system. These types of requirements include aspects such as speed, accuracy of computations, or security. These types of requirements won't be as vital to the software side of Medlock as they are to the hardware portion. That being said the most important performance requirement for the software is the accuracy of the clock system in place because that will be a major factor in the pill disbursement process.

Reliability and maintainability testing is done to determine how reliable the product software is and how easily it can be maintained. For this section, the maintainability of the software shouldn't be a problem in that the software isn't going to be very conducive to constant updates due to the products uses. Meaning that once the code is loaded in there shouldn't need to be any real updates to the software to maintain the functionalities of Medlock. The reliability portion of this testing is far more important because the product will be responsible for holding and dispensing drugs that could mean the difference between life and death in certain scenarios. Therefore, reliability testing will need to be extensive and constant.

The last type of testing that will be used for the software testing portion is integration testing. Integration testing is a significant process in all forms of software development. While individual sections of the code may work well on their own, the code can't be seen as effective until those co-dependent sections and eventually overall system are tested together. When it comes to the Medlock system there are several functional requirements that rely heavily on each other, such as the notification system and servo motor use for the overall pill disbursement. Due to this integration testing will prove to be a significant portion of the testing done within the project.

7.2.1 Unit Testing Strategies

Unit testing is a good place to start when testing a system because it breaks the system down into its smallest components. Unit testing focuses on ensuring that each component functions correctly by itself before integrating it with other components. This strategy works very well with software because software, when written well, is broken into functions that serve a specific purpose to the functionality of the system. Having a code broken into many different functions makes it very easy to unit test the system, just take the individual functions and

run test cases through them to ensure that the data being inputted makes sense with the data that is being outputted.

There are three main steps to follow when unit testing, those steps being determining what is being tested, what test cases are going to be used, and defining a test and how it will be implemented into the system. Although very basic, these three steps are a very crucial part of unit testing and ensuring that the units are working as they are supposed to. These steps allow the tester to formulate a plan to test every aspect of a unit, or a function, in the software in order to verify that the unit is doing what it was designed to do with no faults.

When determining what is being tested, the focus is on individual functions. The whole point of the first step is to pick out a specific part of the software, a function or method, and determine if when being called upon it is working correctly. The next step, determining what test cases are going to be used, requires more thought from the user. Picking test cases is a very critical part of testing to determine if the software is working correctly. Test cases must be selected in a fashion that suites the software or function being tested. What is meant by this is test cases being used to test the software must correspond to what the software was designed to do. To go further into detail about test cases, good test cases are cases that are designed to try and break the system. When testing in general, not just unit testing, it is important to not prove that the system works, but rather try to break the system in order to find faults that need to be fixed. The final steps in unit testing, defining a test, is usually done one of two ways when testing software, those ways being closed or open box testing. In closed box, sometimes referred to as black box testing, the functionality of the function being tested based on input and output. What is meant by this is this method checks how the outputs compare to the inputs, it checks for a trend between the outputs and inputs. Closed box is a good choice when the function that is being tested is simple; this is because when using the closed box system, it is difficult to create sets of test cases. In open box, sometimes referred to as white box, the structure of the function is being tested. What is meant by this is test cases are sent into the function that will execute every aspect of the function. Using the open box method will ensure every aspect of the function is working correctly. The open box method is a very good method to use, however it is difficult to test in cases where the function uses iteration or recursion, in this case the open box method would seem impractical to use.

The next step of unit testing is to test the thoroughness of the unit that is being tested. There are many ways to test the thoroughness of a unit; some widely accepted methods include statement testing, branch testing, path testing, definition-use path testing, all-uses testing, Statement testing is designed so that when tested, every statement in the function is executed, this will ensure that every statement in the code is working correctly. Branch testing is very similar to statement testing, but instead of statements being checked every branch in the function is executed. Using this method will ensure that the function being tested

is making the correct jumps to the correct places at the correct times. Path testing is designed in a way where every path in the function being tested is executed. Using this method will ensure that the function is doing the correct order of operations when given an input. Definition-use path testing is designed so that on execution every variable and path is tested. Using this method will ensure that every variable in the function is holding the correct data and that the code is following the correct route when given an input. The method all-uses testing is a bit impractical in some cases, but can be very effective in more simple functions. All-uses testing will print a chosen variable every time it is used in execution. This method will allow the tester to see how the data that the variable is holding changes as the function is executed. Typically, only one of the methods defined above would suffice when testing for thoroughness of a function. Usually when one of the methods is used, the faults that can be found using other methods will be found, however it might not be as efficient as using a different testing method.

7.2.2 Amount of Testing

Testing software is a very critical part of ensuring that the software and all of its components are working correctly, but it is also important to know when to stop testing.

A typical rule to follow is that if faults are being found in the software, there are typically more that have not been found. Faults found and the probability that faults still exist in the software have a proportionality that is similar to a cubic root function. To describe this proportionality, finding a couple faults in the beginning of testing is very typically, they are usually small errors that can be quickly fixed; at this point in testing the probability of more faults existing in the code is relatively low. However, if as testing continues and more faults are found typically the trend that is followed is that the probability of more faults existing in the software goes up. A good way to determine when to stop testing is by using a classification tree. A classification tree is a technique that is used to sort through arrays of information regarding measurements taken during the testing of software. This information is then used to make a decision tree to determine when the software has met the requirements to stop testing. The tree also helps determine which parts of the software are more likely to have more errors. Figure 42 below is an example of a classification tree.

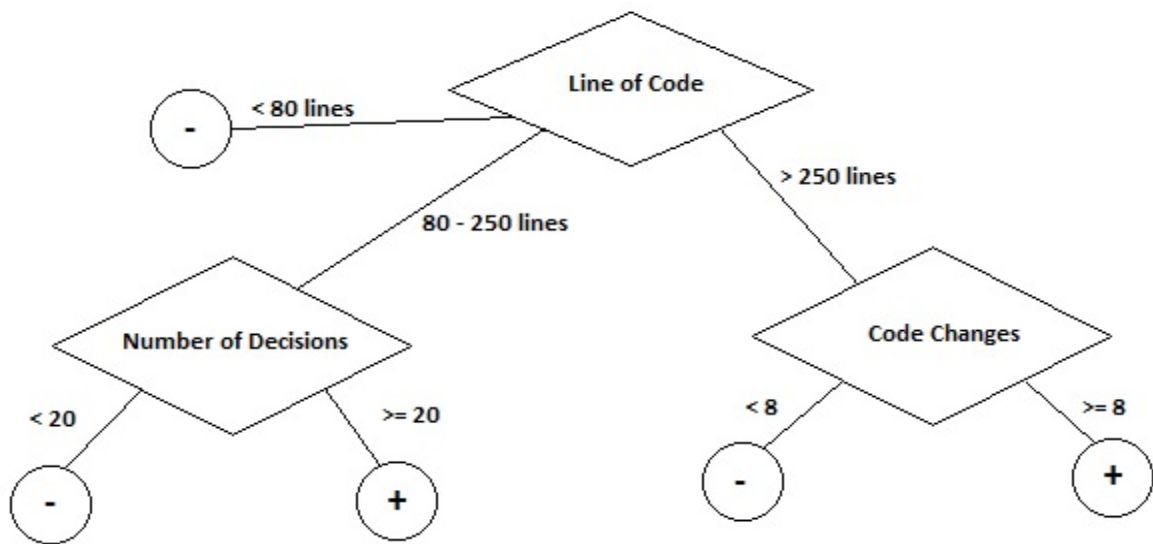

Figure 42: Classification Tree [Custom made in Microsoft Paint]

The way to follow the above classification tree is to follow the path in the tree that corresponds to the software being tested. When using a classification tree, the percentage of test cases that have been successfully passed should be known, and the tree will come with a minimum passing rate. For example, if the software being tested is meeting the classification tree's minimum test case passing rate and the software has less than 80 lines of code, it would be determined that enough testing has been done and the software should be very close to fault free if it is not. The basic idea behind the classification tree is the more components that are present and the more changes that are made to the software the higher chance of there being faults that have not been found. The tree gives the tester a route to take in order to ensure that the code is functioning correctly with zero or minimal faults.

7.2.3 Software System Testing

The final step in testing software is testing the software as a system rather than by single units or integrated units. When testing the system, the main focus is no longer faults that appear in the software functions but rather failures that appear when the user uses the system. To clarify quickly, faults are errors in the software caused by the coder failures are when the system fails to do what it was designed to do, faults usually lead to failures. When testing the system as a whole there are a couple steps that can be followed to ensure effectiveness of testing. Those steps include function testing, performance testing, acceptance testing, and installation testing. These four steps focus on how the integrated units of the system act as one single unit.

Function testing focuses on determining whether or not the integrated units of the system work as declared when defining the requirements specification. This method of testing focuses on making sure that all the components of the system work together fluently and allow the system to perform the actions that it was designed to do. When using the function testing method all components have to work together and create the correct outputs, even if one of the components fails the whole system fails, and the tester must sort through the code and determine what component caused the system to fail and how. Function testing is not complete until the every component works together in the system to produce the correct outputs without and failures. Next performance testing is implemented into testing the software system. Performance testing tests the non-functional aspects of the software system. What are meant by non-functional aspects are components like security and speed of the system, just for example. When designing a requirement specification for the system the customer will define exactly how they want the system to work. If after the software has been designed and created some components that are non-functional do not meet the requirements listed on the requirement specification then the designers and coders must redesign parts of the code to meet the requirements of the customer. Typically, the speed of the system is the contributing factor of failures in performance testing, causing the designers and coders of the system to make the system more efficient to meet the requirements. Once the function testing and performance testing have been completed and satisfied and the system is operating in a fashion that the designers intended, the system is now called a verified system. Once the system fulfills requirement on the requirement specification the system can be called a validated system. The goal after function testing and performance testing is to have a system that is verified and validated.

The next steps in testing a software system are testing the system according to the customer the software is designed for; these two steps are acceptance testing and installation testing. In acceptance testing the customer has to determine if the software that has been designed for them is what they requested. Often times when designing a system, the designers will try to shortcut areas in the design to make the coding processes easier. If this happens it is up to the customer to determine if they will accept the software system or not. The next and final step in testing a software system is the installation test. This test determines if the system runs properly in the environment it was designed for. When the customer defines everything that the system needs to do they also describe what kind of environment the system must be able to perform in. If the installation test fails the software system is useless to the customer until the system is fixed and able to run in the specific environment that the customer requested. Once the system passes the acceptance and installation test and the system is operating as the customer requested in the environment the customer requested, the system is called an accepted system.

The process the software must go through in order to be in use by the customer is defined by the flow chart below. This chart shows all the different tests in

sequence that the software must go through as units and as a whole system. The chart also shows what tests must be passed for the system to be considered a verified, validated, and accepted system.

7.2.4 Integration Testing Strategies

With integration testing being such an important and wide spread factor in the software development field there are many different strategies to choose from. This section will explore three such strategies and explain the reasoning behind the decision of which one to go with.

7.2.4.1 Top-Down Integration Testing

Top-Down integration testing is a style in which testing is begun at the higher-level components of the overall system and then the subsequent modules below are tested together with the higher-level module. The use of stubs to simulate lower modules creates a high overhead for testing. It also may delay some testing and make the overall time for testing the integration of the system longer. While those are the drawbacks of the system its major advantage is it helps with the early verification of the major modules within the system.

With the information previously stated, Top-Down testing would not be the most beneficial integration testing practice for the Medlock. The creation of stubs is a time-consuming process and even if they allow for the higher-level modules to work, the lower level modules will still have to be programmed to replace the stubs and tested with the higher level program. That means many hours are spent creating simulations of specific features within the program for no reason other than to test higher level modules early. Along with that is the fact that there will only be a few months available for the programming and testing of the system therefore an extended testing length would be detrimental in the creation and testing of the Medlock system. Due to these reasons Top-Down integration testing is not the best suited for the development of our product.

7.2.4.2 Big Bang Integration Testing

This testing process is also known as the “Run it and See” process. In Big Bang integration testing all the modules or units are created separately. Once all the modules needed for the system are finished then they all are compiled together. This form of integration testing focuses on doing as little testing as possible. The idea is that if each of the individual modules can pass their unit testing and are coded effectively then the system will only have to run through a small amount of integration testing. Therefore, if properly achieved then Big Bang integration testing would be the quickest of the possible techniques. The problem is that if the units aren’t coded very well and don’t work together as they functionally should, then the process can be extremely complicated and severely detrimental in the overall testing process.

As seen in the previous paragraph Big Bang integration testing, even with skilled and experienced programmers, can be highly risky. While there can also be a big reward if done properly there are far too many factors that make this choice dangerous. With the limited time period for the production and testing of the Medlock system you could make an argument for Big Bang, but the problem is that this method is risky even with highly experienced programmers so college students probably won't fair as well. If the system has integration faults then they will be much harder to identify using this type of testing due to the large amount of moving parts being tested at once. Overall while Big Bang testing could result in a high reward based off time saved, the risks that are taken when using this strategy are far too high for our development process.

7.2.4.3 Bottom-Up Integration Testing

The Bottom-Up integration testing process is almost the exact opposite of Top-Down. In Bottom-Up the lower level modules are tested individually first then are used in the integration testing of the modules above them, this continues until the top of the hierarchy is tested. For this type of testing to work component drivers are necessary. These are much easier to create and use then stubs are, allowing for better facilitation of testing. This allows for a quicker overall testing process and simpler test case design. The major drawback being that the overall system isn't created until all of the modules have been completed and successfully integrated.

Bottom-Up integration testing is the best fit for our project. With a limited amount of time integration testing needs to be somewhat quick. This type of testing allows us to avoid the creation of stubs which can be daunting and time consuming as well as simplify the design of test cases further streamlining the process. The drawback of this approach as previously stated is that the overall system isn't created until all of the modules are complete with the higher level being last. For Medlock purposes, most of the higher level functions would be basically useless without the lower tier functions accompanying them making it so the lower level are almost just as important as the upper. This makes it so the one major drawback of this integration testing process isn't as detrimental as it would be for other products. Overall Bottom-Up integration testing best fits our project demand and therefore will be the strategy we implement.

7.2.5 Integration Testing Hierarchy

For integration testing to be more effective there needs to be an overall system hierarchy described. This shows the dependencies amongst the various modules (or functions) and determines the order in which they should be created and integrated into the overall software design. The picture below, figure 43 displays the software hierarchy for the Medlock system.

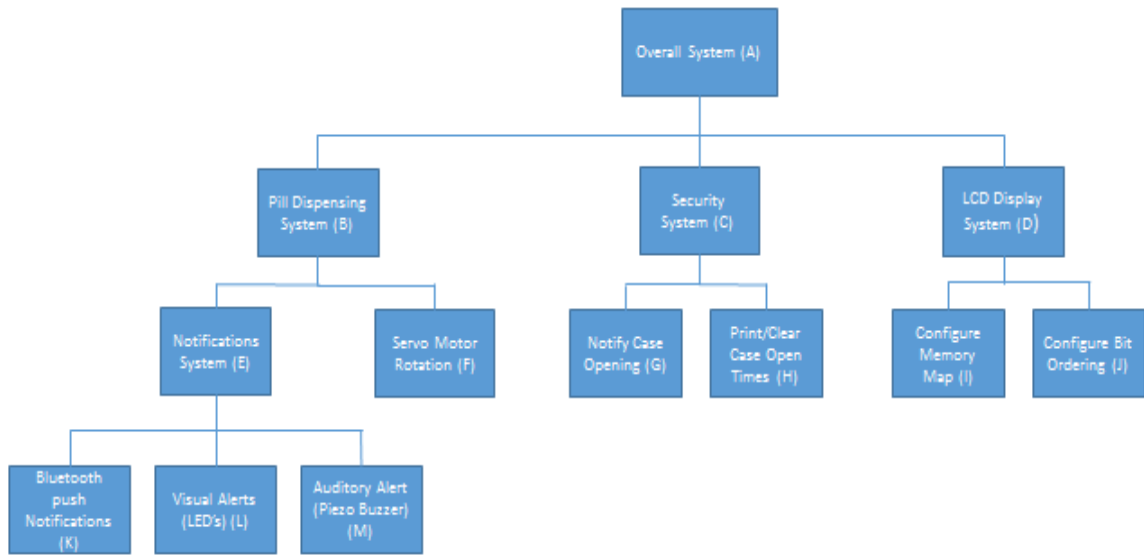

Fig 43: Software Hierarchy

With the use of Bottom-Up integration testing practices the order of testing for the figure above would be K, L, M then E, K, L, M (together) and so on, testing upwards until all the modules are integrated together. This assures that first the dependencies for systems work properly then those systems combined and so on until the full system is tested all together. This allow for easy fault detection and prevention.

7.2.6 Test Description Chart

In the software design section of this document there was a requirements traceability matrix. This matrix is used to make sure that there is no miscommunication of requirements between the client and the programmers while also helping the people working on the project keep track of what needs to be done. The traceability matrix also proves impactful when it comes to creating test cases to properly test the full functionality of the overall system. That being said another tool that is effective in product development is a test description chart. This is basically the testing equivalent to the software requirements traceability matrix and serves as a basis for the various tests that need to be fulfilled through the testing process. Table 12 below lays out the functionalities that need to be tested as well as the process to be taken and the expected outcome for each test case.

Test Case Reference	Test Objective	Test Description	Expected Results
TC1	Servo Movement	Press the push button attached to the servo motor and see if it	This will be separate from how it will be used in pill disbursal;

		moves.	the expected result is that when the button is pushed the servo will rotate.
TC2	Audio Notification	Measure the time required before a pill is ready when the Boolean flips to tell the pill is ready, count 10 additional minutes then check if the piezo buzzer gives an audio notification.	When the pill is ready to be dispensed the piezo buzzer will go off 10 minutes after the pill is ready to be dispensed, this is by design.
TC3	Visual Notification	When the Boolean becomes true stating that the pill is ready to be dispensed look to see if the LED signifying this is blinking.	When the Boolean is flipped, and the pill is ready the LED should blink until the pill is disbursed.
TC4	Bluetooth Notification	When the pill is ready to dispense see if a Bluetooth notification has been sent to the connected phone.	Connect a phone (needs to be done on both android and iOS), when the pill is ready the user should receive a Bluetooth push notification within 3 minutes.
TC5	Pill Disbursal	When the pill is ready, push the button and make sure the pill gets disbursed.	When the pill is ready the notification should go of then when the button is pushed the servo motor will rotate and dispense the pill.
TC6	LCD display	Make sure that the text that is programmed to be shown on the LCD display is there.	The LCD display should show what is programmed for it to display.
TC7	Security Notification	Open the casing and check if a time stamp is recorded into the program memory.	Every time the case is opened that time stamp should be saved into an array.
TC8	Security notification deletion when reaching 10 entries	Continually open the case and make sure the oldest time stamp	Every opening after 10 should delete the oldest opening in the

		is deleted following the 11 th opening.	array.
--	--	--	--------

Table 12: Test Description Chart

The test description chart will act as a blueprint for the testing of the project throughout the development process. This chart creates tests for each of the planned functionalities for the project from the software side. This chart will continue to be updated throughout the project implementation as Medlock functionalities may change or additional test cases may be developed throughout the semester. Overall this should prove to be an effective tool in the overall testing process.

8. Administrative Content

This section examines all the administrative portions of the project that aren't shown in the body of this paper. These include sections such as budget and finance, where the expenses are explained and project milestones in which we lay out the milestones for Senior Design 1 and 2.

8.1 Budget and Finance

For any project a crucial factor that determines its possible earning power is the overall cost to make each individual product unit. This section lists all the parts selected and how much each of the individual parts costs. For the actual creation of the product we will only actually need 1 set of each part, but for prototyping purposes we have ordered 3 of each in case some parts get broken or damaged in the process. Table 13 below shows the parts chosen and their price.

Part Name	Model Number	Part Count	Supply Voltage (V)	Supply Current (mA)	Price per Unit (\$)	Price (\$)
Microcontroller	CC2650(RHB)	1	1.8-3.8	0.048	2.45	2.45
Battery	Tenergy Li-Ion 18650	1			34.99	34.99
LED(White)	L1-0-W5TH70-1	1	3.6	0.03	0.49	0.49
LED(Red)	L2-0-R5TH50-1	1	2.2	0.03	0.49	0.49
LCD Screen	ERM1604 SYG-1	1	3.3-5	0.045	5.16	5.16
PCB		1				
USB-C Header	10137061-00021LF	1	NA	5	2.82	2.82
IR Sensor		1	5	0.02	6.5	6.5
Button	ESB-	1	3-14	.00005-.2	1.49	1.49

	30B102					
Voltage Regulator						
Mux		1	1.65-5.5			
Piezoelectric Buzzer	PS1240P0 2BT	1	3	0.009	0.72	2.16
Servo Motor	HXT900	2	3-6	0.75	2.99	8.97
20 Pin Connector	571- 1041284	1	NA		3.58	3.58
TOTAL						

Table 13: Part Pricing

8.2 Milestones

The milestone section will give an overview of the milestone schedule that was used for Senior Design 1 and also the milestone plan for Senior Design 2.

8.2.1 Senior Design 1 Milestones

Senior Design 1 represented the research portion of the project. There was originally a planned milestone section that was turned in within the first few weeks of class. For the most part there will be the same milestones as were listed originally but with a few adjustments now that the semester is over and we know what milestones we actually set and followed. The milestone table for Senior Design 1, table 14, is shown below.

Number	Task	Date Finished by
1	Select Group	8/25/17
2	Bootcamp assignment.	9/1/17
3	Select Project Idea	9/8/17
4	Complete Divide and Conquer Assignment	9/22/17
5	Meet with Coordinator to review Divide and Conquer paper.	9/28/17
6	Re-submit updated Divide and Conquer	10/20/17
7	Finish Assignment on Standards (Quizzes)	10/20/17
8	60 Page Draft	11/3/17
9	Meeting for review of 60-	11/6/17

	page draft	
10	100 Page Draft	11/17/17
11	Edit of 100-page draft based on feedback	11/24/17
12	Order Parts	11/27/17
13	PCB Prototype Design creation.	12/1/17
14	Turn in final paper	12/4/17

Table 14 : Senior Design 1 Milestones

8.2.2 Senior Design 2 Milestones

Senior Design 2 is the semester in which the product is created. While the milestones for Senior Design 1 were all about research and documentation, the milestones in this section will focus on the building of Medlock. Therefore, the milestones will be based of software and hardware design portions and large sections of testing. Unlike Senior Design 1 where all the milestones are 100 percent correct because they are all finished, this section will be a mere plan of what our group hopes to accomplish on a weekly or bi-weekly basis. This means that due to possible unforeseen circumstances all the milestones shown in Table 15 below are subject to change.

Number	Task	Date Finished by
1	SolidWorks Design to Print 3D Casing	1/15/18
2	Creation of LCD Display Software	1/19/18
3	Creation of Servo Motor Software	1/26/18
4	Creation of PCB	1/26/18
5	Creation of Disbursal Mechanism.	1/29/18
6	Testing of LCD and Servo Motor Functions	2/3/18
7	Testing of PCB	2/3/18
8	In Class PowerPoint Presentation	2/2/18
9	Creation of Notification Functions	2/24/18
10	Creation of full pill disbursal function.	3/3/18
11	Integration Testing of Software thus far	3/10/18
12	Creation of Security	3/17/18

	Functions	
13	Integration of Full Software System.	3/24/18
14	Remediation Testing of Software	4/1/18
15	Combining all Parts into the outer casing.	4/8/18
16	Testing the product as a whole.	4/15/18
17	Making Final Adjustments and writing Senior Design 2 paper	4/22/18
18	Presenting Final Project	4/16/18

Table 15 : Senior Design 2 Milestones

9. Project Summary and Conclusion

This semester every student enrolled in Senior Design 1 was tasked with finding a group to create a project that would give them some practical experience. The whole process seemed like a whirlwind of uncertainty and adaptation. In the first week groups were created, then an idea had to be created. Then came the real work, the driving factor of the class, research. For months the operative was to learn everything possible while properly delegating the work among team members and balancing the stresses of other classes. Weeks upon weeks of writing and pressure packed deadlines, counting white space to make sure the page count is accurate. That said the end result couldn't be more rewarding, a 120 plus page report filled with research and effort that will ultimately lay the groundwork for the creation of a product of our own.

This semester our group set out to create the Medlock device, a secure pill dispensing system to combat the issue of opioid abuse. This product would be best used at the pharmacy level and is in theory designed to replace the pill bottles that are currently used. For us to accomplish this task there were many factors that had to be looked at and a large amount of research had to be done. The functionalities of the product include a notification system (audio, visual, and Bluetooth), a security sensor, pill dispensing mechanism, and a security system using a magnetic system accompanied with software and hardware design. For us to accomplish our goals for this project, the first step that needed to be taken was large amounts of research. As you can see throughout the paper our group researched a wide variety of possibilities for each individual part that will be incorporated in the design. On top of that there were many new aspects of our majors that needed to be explored such as the design of PCB's or the programming of Bluetooth on a microprocessor. Through this research we learned many things about ourselves as well as the process of working with a group to create a product in the world of engineering. This was just the first step of the process though, in the next few paragraphs the ideas and plan that will be carried into Senior Design 2 will be discussed.

9.1 A Look Forward to Senior Design 2

With the research portion of the assignment being officially over, now comes the interesting portion of the project. While research is crucial to any profession, proper use of the knowledge gained in the research portion is just as important. In theory we already have all of Senior Design 2 planned out from the creation of the PCB to the design of the software to the integration of the various systems within the product as a whole. This next semester will be a test in adaptability and learning on our feet so to say. If anything has been learned from school it is that things almost never go as planned and problem solving will be of the utmost importance to avoid spending our nights in the lab to end the semester. There several strategies that we plan to use to avoid the stress of last minute product building and testing.

The first strategy in which we plan to use is the setting of milestones and the following of the deadlines we set for each. As can be seen in previous sections of the paper there is a chart that lays out all of the milestones that must be accomplished to finish the project on time. These milestones not only work as a schedule for when to accomplish each process but also a blueprint of everything we need to do. By strictly following the schedule implemented through the creation of such objectives our group can ensure a smoother pace and less stressful semester.

Another strategy which will make life easier for us in Senior Design 2 is the use of constant and varied testing. Within the industry testing is extremely important, that is why there are whole departments dedicated solely to quality assurance. We already have someone started to create testing procedures that we believe will be helpful for the spring semester. One such procedure can be seen in this paper is the use of both requirements traceability matrix and testing description table. These two go hand in hand with one another, the requirements traceability matrix (or RTM) lays out all the functional and non-functional requirements for which the product, in our case Medlock, must meet. These requirements are things such as the “notifications must occur when the pill is ready and stop when the pill has been disbursed”. This allows for the producers to know what functionality has been achieved and what still needs to be worked on. The testing description table serves as the basis for deciding whether or not the requirements in the traceability matrix have been successfully met. The entries in the testing matrix are actual tests that have been designed to check if the requirements are properly satisfied. Having these two procedures in place should give us a step up in the testing portion of Senior Design 2. That being said consistent and constant functional and regression testing will be crucial for a successful Senior Design 2 project to be finished.

The final strategy is one that was also extremely helpful in the Senior Design 1 process as well. This strategy is just the use of constant and constructive communication between the members within our group. This means that not only do we have open communication throughout the week but the communication is beneficial and positive. For instance if someone within the group is struggling with an aspect of the project, they should feel fine telling the group their issues, and the group should rather than be negative offer help and positive reinforcement to that group member. This is something that our group has done well throughout this semester and hopes to continue into the final semester of Senior Design.

Now that our strategies have been discussed and our group has finished Senior Design 1 we can finally delve into the waters of the design aspect of the industry. Through our paper and what we have learned through the course of the class, we believe that a solid platform has been formed for us to stand on as Senior Design 2 descends upon us. All the research and learning form this semester

has properly set us up for the road ahead and the challenges that will ultimately be faced. We know that it will be a bumpy road full of twist and turns because nothing in engineering is ever simple. With that being said though we are extremely excited because we have a product we believe in and ultimately we can't wait to finally create the Medlock.

Appendix

Citations

- [1] "Opioid Overdose," Centers for Disease Control and Prevention, 30-Aug-2017. [Online]. Available: <https://www.cdc.gov/drugoverdose/epidemic/index.html>. [Accessed: 02-Nov-2017].
- [2] CareFusion, "Measurable improvements in medication management Pyxis MedStation™ 4000 system," Measurable improvements in medication management Pyxis MedStation™ 4000 system. San Diego, Ca, 2011.
- [3] "Adafruit Motor Selection Guide," Servo Motors | Adafruit Motor Selection Guide | Adafruit Learning System. [Online]. Available: <https://learn.adafruit.com/adafruit-motor-selection-guide/rc-servos>. [Accessed: 02-Nov-2017].
- [4] Battery Block Level Schematic. Texas Instruments, 2005.
- [5] Bluetooth Module with MSP430. 2013.
- [6] Magnetic Sensor Reed Switch. Engineers Garage.
- [7] "Lab 12: Basics of LED dot matrix display," Embedded Lab, 18-May-2013. [Online]. Available: <http://embedded-lab.com/blog/lab-12-basics-of-led-dot-matrix-display/>. [Accessed: 02-Nov-2017].
- [8] Jon Stokes - Aug 11, 2009 12:50 pm UTC, "This September, OLED no longer "three to five years away"," Ars Technica, 11-Aug-2009. [Online]. Available: <https://arstechnica.com/gadgets/2009/08/this-september-oled-no-longer-three-to-five-years-away/>. [Accessed: 02-Nov-2017].
- [9] S. Keach, "What is OLED? A complete guide to the iPhone X's new screen," Trusted Reviews, 25-Sep-2017. [Online]. Available: <http://www.trustedreviews.com/news/what-is-oled-3285263>. [Accessed: 02-Nov-2017].
- [10] P. Systems, "Vibration Speaker Technology - Massive Force : Micro Vibrations," The Vibration Speaker. Massively Powerful Surface Speakers. [Online]. Available: <http://www.feonic.com/vibration-speaker-technology>. [Accessed: 03-Nov-2017].
- [11] V. Beal, "Wi-Fi (wireless networking)," Wi-Fi (Wireless Networking) Definition | Webopedia. [Online]. Available: https://www.webopedia.com/TERM/W/Wi_Fi.html. [Accessed: 03-Nov-2017].
- [12] "Frequency-hopping spread spectrum," Wikipedia, 21-Apr-2018. [Online]. Available: https://en.wikipedia.org/wiki/Frequency-hopping_spread_spectrum. [Accessed: 26-Apr-2018].
- [13] "BlueTooth-HC05-HC06-Modules-How-To," arduino-info. [Online]. Available: <https://arduino-info.wikispaces.com/BlueTooth-HC05-HC06-Modules-How-To>. [Accessed: 03-Nov-2017].
- [14] "RN42," Microchip Technology Inc. [Online]. Available: <http://www.microchip.com/wwwproducts/en/RN42>. [Accessed: 03-Nov-2017].

- [15] "HXT900 Micro Servo 1.6kg / 0.12sec / 9g," Hobbyking. [Online]. Available: https://hobbyking.com/en_us/hxt900-micro-servo-1-6kg-0-12sec-9g.html. [Accessed: 03-Nov-2017].
- [16] "Welcome to Battery University!," Basic to Advanced Battery Information from Battery University. [Online]. Available: <http://batteryuniversity.com/>. [Accessed: 03-Nov-2017].
- [17] "Battery 101: Trickle vs. Regular Battery Charger," Northeast Battery, 27-Oct-2017. [Online]. Available: <https://northeastbattery.com/trickle-charger-versus-regular-battery-charger/>. [Accessed: 09-Nov-2017].
- [18] "BU-411: Charging from a USB Port," Charging Batteries From a USB Port – Battery University. [Online]. Available: http://batteryuniversity.com/learn/article/charging_from_a_usb_port. [Accessed: 09-Nov-2017].
- [19] "BU-808: How to Prolong Lithium-based Batteries," How to Prolong Lithium-based Batteries - Battery University. [Online]. Available: http://batteryuniversity.com/learn/article/how_to_prolong_lithium_based_batteries. [Accessed: 09-Nov-2017].
- [20] "MSP430FR5858 (ACTIVE)," MSP430FR5858 MSP430FR5858 16 MHz Ultra-Low-Power Microcontroller featuring 48 KB FRAM, 2 KB SRAM, 33 IO | TI.com. [Online]. Available: <http://www.ti.com/product/MSP430FR5858/description>. [Accessed: 02-Nov-2017].
- [21] A. Boe, "CC2538/CC26xx Serial Bootloader Interface." Texas Instruments, 2015.
- [22] "Tubular pin tumbler lock," Wikipedia, 26-Oct-2017. [Online]. Available: https://en.wikipedia.org/wiki/Tubular_pin_tumbler_lock. [Accessed: 16-Nov-2017].
- [23] "Pin tumbler lock," Wikipedia, 02-Nov-2017. [Online]. Available: https://en.wikipedia.org/wiki/Pin_tumbler_lock. [Accessed: 16-Nov-2017].
- [24] G. Contributor, "What are Standards? Why are They Important?," Beyond Standards, 15-Dec-2016. [Online]. Available: <https://beyondstandards.ieee.org/general-news/what-are-standards-why-are-they-important/>. [Accessed: 02-Nov-2017].
- [25] "HIPAA Privacy Rule and Its Impacts on Research," National Institutes of Health. [Online]. Available: https://privacyruleandresearch.nih.gov/pr_06.asp. [Accessed: 02-Nov-2017].
- [26] CFR-2007-title45-volume1, vol. 1. 2007.
- [27] "ISO - International Organization for Standardization," ISO/IEC/IEEE 9945:2009 - Information technology -- Portable Operating System Interface (POSIX®) Base Specifications, Issue 7, 17-Dec-2014. [Online]. Available: <https://www.iso.org/standard/50516.html>. [Accessed: 02-Nov-2017].
- [28] "2003.1b-2000 - IEEE Standard for Information Technology-Test Methods Specifications for Measuring Conformance to POSIX(R) - Part 1: System Application Program Interface (API) -Amendment 1: Realtime Extension [C Language]," IEEE SA - 2003.1b-2000 - IEEE Standard for Information Technology-Test Methods Specifications for Measuring Conformance to POSIX(R) - Part 1: System Application Program Interface (API) -Amendment 1: Realtime Extension [C Language], 30-Mar-2000. [Online].

Available: <https://standards.ieee.org/findstds/standard/2003.1b-2000.html>. [Accessed: 02-Nov-2017].

[29]“29148-2011 - ISO/IEC/IEEE International Standard,” 29148-2011 - ISO/IEC/IEEE International Standard - Systems and software engineering -- Life cycle processes -- Requirements engineering - IEEE Standard, 2011. [Online]. Available: <http://ieeexplore.ieee.org/document/6146379/>. [Accessed: 02-Nov-2017].

[30]“1625-2004 - IEEE Standard for Rechargeable Batteries for Portable Computing,” IEEE SA - 1625-2004 - IEEE Standard for Rechargeable Batteries for Portable Computing, 08-Apr-2004. [Online]. Available: <http://standards.ieee.org/findstds/standard/1625-2004.html>. [Accessed: 02-Nov-2017].

[31]“IEEE APPROVES IEEE 802.15.1 STANDARD FOR WIRELESS PERSONAL AREA NETWORKS ADAPTED FROM THE BLUETOOTH® SPECIFICATION.” IEEE, 26-Mar-2002.

[32]“Microsoft Word - Battery Management Reference Design for Smartwatch and Wearable Applications V0.4.” Texas Instruments, Oct-2015.

[33] “BQ25606 (ACTIVE),” BQ25606 datasheet Stand Alone Single Cell 3-A Fast Charger with High Input Voltage and Power Path | TI.com. [Online]. Available: <http://www.ti.com/product/BQ25606/datasheet/detailed-description#SLUSCJ49625>. [Accessed: 16-Nov-2017].

[34]“TPS55330 (ACTIVE),” TPS55330 datasheet Integrated 5-A 24-V Wide Input Range Boost/SEPIC/Flyback DC-DC Regulator | TI.com. [Online]. Available: <http://www.ti.com/product/TPS55330/datasheet/abstract#SLVSBX84597>. [Accessed: 03-Dec-2017].

[35] “TPS62097 (ACTIVE),” TPS62097 datasheet 2-A Step Down Converter with Selectable Switching Frequency in HotRod package | TI.com. [Online]. Available: <http://www.ti.com/product/TPS62097/datasheet>. [Accessed: 03-Dec-2017].

[36] “TPS5401 (ACTIVE),” TPS5401 datasheet 3.5V to 42V Input, 0.5 A Step Down Converter | TI.com. [Online]. Available: <http://www.ti.com/product/TPS5401/datasheet>. [Accessed: 03-Dec-2017].

[37] “TPS63020 (ACTIVE),” TPS63020 datasheet High Efficiency Single Inductor Buck-Boost Converter with 4A Switch | TI.com. [Online]. Available: <http://www.ti.com/product/TPS63020/datasheet/pin-configuration-and-functions#SLVS9162933>. [Accessed: 03-Dec-2017].

[38] “LP5907 (ACTIVE),” LP5907 datasheet 250mA Ultralow-Noise Low-IQ LDO | TI.com. [Online]. Available: <http://www.ti.com/product/LP5907/datasheet>. [Accessed: 03-Dec-2017].

[39] “CC2640 and CC2650 SimpleLink™ Bluetooth® low energy Software Stack 2.2.1.” Texas Instruments, Oct-2016.

[40] L. L. C. K. A.- Epec, “Using Heavy Copper and EXTREME Copper in PCB Design and Fabrication for Maximum Reliability,” Epec Engineered Technologies - Build to Print Electronics. [Online]. Available: <http://www.epectec.com/articles/heavy-copper-pcb-design.html>. [Accessed: 03-Nov-2017].

[41] P. Jackson, "Making connections in the printed circuit board industry with tips, commentary and news written just for you.," How Copper Weight Impacts PCB Board Manufacturing. [Online]. Available: <http://www.omnicircuitboards.com/blog/bid/324888/How-Copper-Weight-Impacts-PCB-Board-Manufacturing>. [Accessed: 03-Nov-2017].

[42] D. Cook, "PCB Solder Mask and Silkscreen," PCB Solder Mask and Silkscreen - Robot Room. [Online]. Available: <http://www.robotroom.com/Silkscreen-and-Solder-Mask-1.html>. [Accessed: 03-Nov-2017].

[43] P. Jackson, "Understanding PCB Manufacturing: Silk-Screening," Omni Circuit Boards. [Online]. Available: <http://www.omnicircuitboards.com/blog/bid/312861/understanding-pcb-manufacturing-silk-screening>. [Accessed: 03-Nov-2017].

[44] "PCB Design Guidelines For Reduced EMI." <http://www.ti.com/lit/an/szza009/szza009.pdf>

[45] Tadiran SEC-13. [Online]. Available: <http://www.cryptomuseum.com/crypto/tadiran/sec13/index.htm>. [Accessed: 17-Nov-2017].

[46] "CC2650 SimpleLink™ Multistandard Wireless MCU." Texas Instruments, Jul-2016.

Permissions

[1]

Thank you for your inquiry to CDC-INFO. We hope you find the following information about permission to use the information Opioid overdose helpful.

Information and images developed by CDC and presented on the CDC website are works of the U.S. Government. This content may include:

- general text information,
- publications for download, or
- graphs. CDC-generated works (including photographs, graphics, images, videos, PSAs) located on this site are in the public domain.

This means that they are meant for public use and are not subject to copyright law protections. Permission is not required for use of public domain items. But, CDC does ask that you credit the agency and contributor whenever the item is used in any publicly distributed media.

You are free to adapt and revise these materials, as long as you distribute the revised materials free of charge. But, if you make changes or revisions, you must remove the CDC name and logo from the materials.

You may also find on the CDC website materials or products that are owned or were created by others. This content may include copyrighted materials and other materials provided by third parties, such as private companies or non-government organizations. These third parties retain all rights, including copyright, to publish or reproduce those documents/images, or to authorize others to do so. This is in accordance with Title 17, Sections 106 through 120 of the U.S. Code. Any copyrighted materials included on the

CDC website were used with the permission of the copyright holder and are not in the public domain. These materials remain the property of their respective owners or creators, and should not be reproduced or otherwise used.

Certain Division of Parasitic Diseases and Malaria material are not part of the public domain. Copyrighted material includes: life cycle images of parasites Blastocystis and Pneumocystis, and electron micrograph images of Gnathostoma; if users are interested in publishing these items, they must obtain permission from the original copyright holder.

Content syndication is a way to have CDC.gov content such as podcasts, eCards, Web pages, widgets, microsites, etc., placed on your site. The syndicated content is automatically updated in real time requiring no effort from your development staff to keep the Web pages up to date. You can present CDC Web content in the look and feel of your site and maintain visitors on your site. Content syndication also allows you to integrate CDC Web content and science with localized content. CDC maintains 2 sites for syndication; Content Syndication at:

<https://tools.cdc.gov>

- The Content Syndication site provides HTML content for Web pages:

<https://tools.cdc.gov>

- The Public Media Health Library (PHIL) provides various media types for syndication including HTML, eCards, podcasts, widgets, infographics, pdfs, buttons, badges, and microsites:

<https://phil.cdc.gov/phil/home.asp>

Most images found in CDC's PHIL are:

- Royalty-free; and
- Available for personal, professional, and educational use in electronic or print media, with appropriate citation.

Please credit CDC and the individual photographer, if his or her name is given. If you're using the images in electronic media, please link back to the PHIL site.

Images other than those in the PHIL may have been licensed for use by CDC from a stock photography service. The licensing vendor may prohibit:

- re-publication,
- re-transmission,
- reproduction, or
- other use of the images.

You may submit questions about re-use of specific images via the Contact CDC page on the CDC website.

Data.CDC.gov is a repository for selected API-enabled (can be visualized and syndicated to external sites) CDC data that have been published and made available to the public. Most of these data are already available through various CDC websites and applications. Data.CDC.gov provides a central way to search for and find these data for re-use and provides mechanisms for creating visualizations (e.g., charts, maps, filtered views). These assets are available for download or may be re-used on your Web page with the provided pre-formatted embed code.

Links to nonfederal organizations are provided as a service. Links are not an endorsement of these organizations or their programs by CDC or the federal government. CDC is not responsible for the content of organization websites found at these links.

Thank you for contacting CDC-INFO. For more information, please call 1-800-CDC-INFO (800-232-4636), visit www.cdc.gov and click on "Contact CDC-INFO," or go to www.cdc.gov/info. This e-mail was sent from an unmonitored mailbox, and CDC-INFO will not respond to replies sent to this mailbox. If you have questions or comments, please send them via our online form at www.cdc.gov/info.

CDC-INFO is a service of the Centers for Disease Control and Prevention (CDC) and the Agency for Toxic Substances and Disease Registry (ATSDR). This service is provided by Verizon and its subcontractors under the Networx Universal contract to CDC and ATSDR.

[2]

We have considered your request submitted on 3/10/2018, 8:21:17 PM. BD will grant your request and will release the material referenced in your submission provided that you, acting as or on behalf of Licensee, agree to the Terms and Conditions of Use attached to this message. Your affirmative response to this message will constitute full acceptance of, and agreement to, these Terms and Conditions of Use.

INSTRUCTIONS: Please do not reply to this message. The Terms and Conditions of Use and the associated permission request that follows must accompany your affirmative response. **FORWARD** this message to copyrights@bd.com and insert the following language in the body of the message: I agree to the attached Terms and Conditions of Use.

Please note that permission is withheld pending receipt by the BD Permissions Processing Group of your response accepting the attached Terms and Conditions of Use.

First Name: Cray

Last Name: Winfrey

Organization: UCF

Name of Individual Authorized to Sign Permission Form (Signatory): Cray Winfrey

Relationship of Signatory to Licensee: Me

Fax Number: NA

Signatory E-mail Address: cray.winfrey@knights.ucf.edu

Relationship with BD: None

Describe in detail the material(s) for which you request permission to reprint: (e.g., include a) the full title, author and copyright date of published article, as well as the document number, if known; or b) distinguishing characteristics of digital images and source description; or c) specific URLs for web page content; or d) full draft of the press release or other marketing material, etc.)

Measurable improvements in medication management Pyxis MedStation™ 4000 system. Copyright date 2011. B. Picture from pg.6 Pyxis MedStation 4000 system typical configuration. file:///C:/Users/Cray/Downloads/DI_Pyxis-MedStation-4000-System_BR_EN.pdf

Catalog Number (if known):

Describe in detail for what purpose the material(s) will be used: I am a Computer Engineering Major at UCF, for my senior project I am doing a small scale automated pill dispenser, and would like permission to use data from the documents referenced above as a whats in the market type section.

For what duration will the material(s) be used? Unsure, its for a paper.

Do you have samples of the material(s) requested? no

Name of your contact at BD: None

Date permission required: 04/27/2018

[3]

Hi Cray,

Thanks for your note.

You are free to use images from adafruit.com in your research paper. We ask that you source the photo as from Adafruit and where possible link to source for reference.

Cheers,

Adafruit Support, Nick

[4]

Texas Instruments is pleased to provide the information on these pages of the World Wide Web. We encourage you to read and use this information in developing new products.

TI grants permission to download, print copies, store downloaded files on a computer and reference this information in your documents only for your personal and non-commercial use. But remember, TI retains its copyright in all of this information. This means that you may not further display, reproduce, or distribute this information without permission from Texas Instruments. This also means you may not, without our permission, "mirror" this information on your own server, or modify or re-use this information on another system.

TI further grants permission to non-profit, educational institutions (specifically K-12, universities and community colleges) to download, reproduce, display and distribute the information on these pages solely for use in the classroom. This permission is conditioned on not modifying the information, retaining all copyright notices and including on all reproduced information the following credit line: "Courtesy of Texas Instruments". Please send us a note describing your use of this information under the permission granted in this paragraph. Send the note and describe the use according to the request for permission explained below.

[5]

Texas Instruments is pleased to provide the information on these pages of the World Wide Web. We encourage you to read and use this information in developing new products.

TI grants permission to download, print copies, store downloaded files on a computer and reference this information in your documents only for your personal and non-commercial use. But remember, TI retains its copyright in all of this information. This means that you may not further display, reproduce, or distribute this information without permission from Texas Instruments. This also means you may not, without our permission, "mirror" this information on your own server, or modify or re-use this information on another system.

TI further grants permission to non-profit, educational institutions (specifically K-12, universities and community colleges) to download, reproduce, display and distribute the information on these pages solely for use in the classroom. This permission is conditioned on not modifying the information, retaining all copyright notices and including on all reproduced information the following credit line: "Courtesy of Texas Instruments". Please send us a note describing your use of this information under the permission granted in this paragraph. Send the note and describe the use according to the request for permission explained below.

[6]

Hi Cray,

Thanks for getting in touch with you. We are fine if you would like to use the information.

Please ensure that you mention EngineersGarage as reference.

Thanks

Bijal

[7]

Hi Cray,

You have the permission to use the content on that page. Make sure you cite the source in your report and final paper.

Best of luck with your senior project.

Raj

[8]

You can cite it in your paper

Eric

[9]

Hi Cray

Yes you may use information from this article. Which image did you want to use? They're not all ours. The first three you can use as they are ours. The other two are from LG and Samsung.

Regards,

[10]

Hello Cray,

Thank you for your enquiry.

We can give you permission to use information from our website <http://www.feonic.com/vibration-speaker-technology> as long as you add a credit/reference to Feonic Technology Ltd and also send us a copy of any work you submit/publish (electronically is fine).

If you need any further technical help or other information, please let us know.

Kind regards, Kam

[11]

Sure, just cite us and link to us.

[12]

To use copyrighted material on Wikipedia, it is *not enough* that we have permission to use it on Wikipedia alone. That's because Wikipedia itself states all its material may be used by anyone, for any purpose. So we have to be sure all material is in fact licensed for that purpose, whoever provided it.

[13]

Hi Nick,

You are welcome to use any information from our wiki. It is all open source. Thank you for asking!

Regards, Terry King

...In the Woods in Vermont USA

terry@yourduino.com

[14]

Hi Nick,

Thanks for reaching out. It should be no problem to use the information as long as it meets one of the categories on the following web page and you follow the procedure if it does: <http://www.microchip.com/about-us/legal-information/copyright-usage-guidelines>

Best,

Microchip PR

[15]

Hello Nicholas,

Use of HobbyKing Images / product info is allowed as long as you credit HobbyKing for the image and information.

Let me know if you need further assistance and good luck with your project!

Regards,

Rob

[16]

Hi Nick,

Yes, you may use the material as requested. Please cite sources where appropriate.

Regards,

John Bradshaw - Marketing Communications Manager

Cadex Electronics Inc. | www.cadex.com

Vancouver | Minneapolis | Frankfurt

Tel: +1 604 231-7777 x319 | Toll Free: 1-800 565-5228

[17]

Nick, thanks for reaching out to our team about referencing our blog for use in your project. You're welcome to use this as a reference, granted you're listing this as a source with proper attribution. For example, if published digitally, would need to link back to this page either in-text or in the footer of your paper.

Best of luck! Let me know if you have any follow-up questions or need any additional help.

Rachel Hampton

[18]

Hi Nick,

Yes, you may use the material as requested. Please cite sources where appropriate.

Regards,

John Bradshaw - Marketing Communications Manager

Cadex Electronics Inc. | www.cadex.com

Vancouver | Minneapolis | Frankfurt

Tel: +1 604 231-7777 x319 | Toll Free: 1-800 565-5228

[19]

Hi Nick,

Yes, you may use the material as requested. Please cite sources where appropriate.

Regards,

John Bradshaw - Marketing Communications Manager

Cadex Electronics Inc. | www.cadex.com

Vancouver | Minneapolis | Frankfurt

Tel: +1 604 231-7777 x319 | Toll Free: 1-800 565-5228

[20]

Texas Instruments is pleased to provide the information on these pages of the World Wide Web. We encourage you to read and use this information in developing new products.

TI grants permission to download, print copies, store downloaded files on a computer and reference this information in your documents only for your personal and non-commercial use. But remember, TI retains its copyright in all of this information. This means that you may not further display, reproduce, or distribute this information without permission from Texas Instruments. This also means you may not, without our permission, "mirror" this information on your own server, or modify or re-use this information on another system.

TI further grants permission to non-profit, educational institutions (specifically K-12, universities and community colleges) to download, reproduce, display and distribute the information on these pages solely for use in the classroom. This permission is conditioned on not modifying the information, retaining all copyright notices and including on all reproduced information the following credit line: "Courtesy of Texas Instruments". Please send us a note describing your use of this information under the permission granted in this paragraph. Send the note and describe the use according to the request for permission explained below.

[21]

Texas Instruments is pleased to provide the information on these pages of the World Wide Web. We encourage you to read and use this information in developing new products.

TI grants permission to download, print copies, store downloaded files on a computer and reference this information in your documents only for your personal and non-commercial use. But remember, TI retains its copyright in all of this information. This means that you may not further display, reproduce, or distribute this information without permission from Texas Instruments. This also means you may not, without our permission, "mirror" this information on your own server, or modify or re-use this information on another system.

TI further grants permission to non-profit, educational institutions (specifically K-12, universities and community colleges) to download, reproduce, display and distribute the information on these pages solely for use in the classroom. This permission is conditioned on not modifying the information, retaining all copyright notices and including on all reproduced information the following credit line: "Courtesy of Texas Instruments". Please send us a note describing your use of this information under the permission granted in this paragraph. Send the note and describe the use according to the request for permission explained below.

[22]

To use copyrighted material on Wikipedia, it is *not enough* that we have permission to use it on Wikipedia alone. That's because Wikipedia itself states all its material may be used by anyone, for any purpose. So we have to be sure all material is in fact licensed for that purpose, whoever provided it.

[23]

To use copyrighted material on Wikipedia, it is *not enough* that we have permission to use it on Wikipedia alone. That's because Wikipedia itself states all its material may be used by anyone, for any purpose. So we have to be sure all material is in fact licensed for that purpose, whoever provided it.

[24]

1. Referencing IEEE standards

IEEE standards may be referenced by title and designation without the requirement for permission, as long as they are cited properly.

[25]

Government information at NLM Web sites is in the public domain. Public domain information may be freely distributed and copied, but it is requested that in any subsequent use the National Library of Medicine (NLM) be given appropriate acknowledgement. When using NLM Web sites, you may encounter documents, illustrations, photographs, or other information resources contributed or licensed by private individuals, companies, or organizations that may be protected by U.S. and foreign copyright laws. Transmission or reproduction of protected items beyond that allowed by fair use as defined in the copyright laws requires the written permission of the copyright owners. Specific NLM Web sites containing protected information provide additional notification of conditions associated with its use.

[26]

Unless specifically stated otherwise, all information on the U. S. Government Publishing Office (GPO) website is in the public domain, and may be reproduced, published or otherwise used without GPO's permission.

[27]

1. Referencing IEEE standards

IEEE standards may be referenced by title and designation without the requirement for permission, as long as they are cited properly.

[28]

1. Referencing IEEE standards

IEEE standards may be referenced by title and designation without the requirement for permission, as long as they are cited properly.

[29]

1. Referencing IEEE standards

IEEE standards may be referenced by title and designation without the requirement for permission, as long as they are cited properly.

[30]

1. Referencing IEEE standards

IEEE standards may be referenced by title and designation without the requirement for permission, as long as they are cited properly.

[31]

1. Referencing IEEE standards

IEEE standards may be referenced by title and designation without the requirement for permission, as long as they are cited properly.

[32]

Texas Instruments is pleased to provide the information on these pages of the World Wide Web. We encourage you to read and use this information in developing new products.

TI grants permission to download, print copies, store downloaded files on a computer and reference this information in your documents only for your personal and non-commercial use. But remember, TI retains its copyright in all of this information. This means that you may not further display, reproduce, or distribute this information without permission from Texas Instruments. This also means you may not, without our permission, "mirror" this information on your own server, or modify or re-use this information on another system.

TI further grants permission to non-profit, educational institutions (specifically K-12, universities and community colleges) to download, reproduce, display and distribute the information on these pages solely for use in the classroom. This permission is conditioned on not modifying the information, retaining all copyright notices and including on all reproduced information the following credit line: "Courtesy of Texas Instruments". Please send us a note describing your use of this information under the permission granted in this paragraph. Send the note and describe the use according to the request for permission explained below.

[33]

Texas Instruments is pleased to provide the information on these pages of the World Wide Web. We encourage you to read and use this information in developing new products.

TI grants permission to download, print copies, store downloaded files on a computer and reference this information in your documents only for your personal and non-commercial use. But remember, TI retains its copyright in all of this information. This means that you may not further display, reproduce, or distribute this information without permission from Texas Instruments. This also means you may not, without our permission, "mirror" this information on your own server, or modify or re-use this information on another system.

TI further grants permission to non-profit, educational institutions (specifically K-12, universities and community colleges) to download, reproduce, display and distribute the information on these pages solely for use in the classroom. This permission is conditioned on not modifying the information, retaining all copyright notices and including on all reproduced information the following credit line: "Courtesy of Texas Instruments". Please send us a note describing your use of this information under the permission granted in this paragraph. Send the note and describe the use according to the request for permission explained below.

[34]

Texas Instruments is pleased to provide the information on these pages of the World Wide Web. We encourage you to read and use this information in developing new products.

TI grants permission to download, print copies, store downloaded files on a computer and reference this information in your documents only for your personal and non-commercial use. But remember, TI retains its copyright in all of this information. This means that you may not further display, reproduce, or distribute this information without permission from Texas Instruments. This also means you may not, without our permission, "mirror" this information on your own server, or modify or re-use this information on another system.

TI further grants permission to non-profit, educational institutions (specifically K-12, universities and community colleges) to download, reproduce, display and distribute the information on these pages solely for use in the classroom. This permission is conditioned on not modifying the information, retaining all copyright notices and including on all reproduced information the following credit line: "Courtesy of Texas Instruments". Please send us a note describing your use of this information under the permission granted in this paragraph. Send the note and describe the use according to the request for permission explained below.

[35]

Texas Instruments is pleased to provide the information on these pages of the World Wide Web. We encourage you to read and use this information in developing new products.

TI grants permission to download, print copies, store downloaded files on a computer and reference this information in your documents only for your personal and non-commercial use. But remember, TI retains its copyright in all of this information. This means that you may not further display, reproduce, or distribute this information without permission from Texas Instruments. This also means you may not, without our permission, "mirror" this information on your own server, or modify or re-use this information on another system.

TI further grants permission to non-profit, educational institutions (specifically K-12, universities and community colleges) to download, reproduce, display and distribute the information on these pages solely for use in the classroom. This permission is conditioned on not modifying the information, retaining all copyright notices and including on all reproduced information the following credit line: "Courtesy of Texas Instruments". Please send us a note describing your use of this information under the permission granted in this paragraph. Send the note and describe the use according to the request for permission explained below.

[36]

Texas Instruments is pleased to provide the information on these pages of the World Wide Web. We encourage you to read and use this information in developing new products.

TI grants permission to download, print copies, store downloaded files on a computer and reference this information in your documents only for your personal and non-

commercial use. But remember, TI retains its copyright in all of this information. This means that you may not further display, reproduce, or distribute this information without permission from Texas Instruments. This also means you may not, without our permission, "mirror" this information on your own server, or modify or re-use this information on another system.

TI further grants permission to non-profit, educational institutions (specifically K-12, universities and community colleges) to download, reproduce, display and distribute the information on these pages solely for use in the classroom. This permission is conditioned on not modifying the information, retaining all copyright notices and including on all reproduced information the following credit line: "Courtesy of Texas Instruments". Please send us a note describing your use of this information under the permission granted in this paragraph. Send the note and describe the use according to the request for permission explained below.

[37]

Texas Instruments is pleased to provide the information on these pages of the World Wide Web. We encourage you to read and use this information in developing new products.

TI grants permission to download, print copies, store downloaded files on a computer and reference this information in your documents only for your personal and non-commercial use. But remember, TI retains its copyright in all of this information. This means that you may not further display, reproduce, or distribute this information without permission from Texas Instruments. This also means you may not, without our permission, "mirror" this information on your own server, or modify or re-use this information on another system.

TI further grants permission to non-profit, educational institutions (specifically K-12, universities and community colleges) to download, reproduce, display and distribute the information on these pages solely for use in the classroom. This permission is conditioned on not modifying the information, retaining all copyright notices and including on all reproduced information the following credit line: "Courtesy of Texas Instruments". Please send us a note describing your use of this information under the permission granted in this paragraph. Send the note and describe the use according to the request for permission explained below.

[38]

Texas Instruments is pleased to provide the information on these pages of the World Wide Web. We encourage you to read and use this information in developing new products.

TI grants permission to download, print copies, store downloaded files on a computer and reference this information in your documents only for your personal and non-commercial use. But remember, TI retains its copyright in all of this information. This means that you may not further display, reproduce, or distribute this information without permission from Texas Instruments. This also means you may not, without our permission, "mirror" this information on your own server, or modify or re-use this information on another system.

TI further grants permission to non-profit, educational institutions (specifically K-12, universities and community colleges) to download, reproduce, display and distribute the

information on these pages solely for use in the classroom. This permission is conditioned on not modifying the information, retaining all copyright notices and including on all reproduced information the following credit line: "Courtesy of Texas Instruments". Please send us a note describing your use of this information under the permission granted in this paragraph. Send the note and describe the use according to the request for permission explained below.

[39]

Texas Instruments is pleased to provide the information on these pages of the World Wide Web. We encourage you to read and use this information in developing new products.

TI grants permission to download, print copies, store downloaded files on a computer and reference this information in your documents only for your personal and non-commercial use. But remember, TI retains its copyright in all of this information. This means that you may not further display, reproduce, or distribute this information without permission from Texas Instruments. This also means you may not, without our permission, "mirror" this information on your own server, or modify or re-use this information on another system.

TI further grants permission to non-profit, educational institutions (specifically K-12, universities and community colleges) to download, reproduce, display and distribute the information on these pages solely for use in the classroom. This permission is conditioned on not modifying the information, retaining all copyright notices and including on all reproduced information the following credit line: "Courtesy of Texas Instruments". Please send us a note describing your use of this information under the permission granted in this paragraph. Send the note and describe the use according to the request for permission explained below.

[40]

Hi Nicholas,

Sales forwarded me your request to use images and content from our site. We give you permission to use both images and content as long as we receive proper citation/source credit within your research and any publications. If you require any hi-res versions of the images in the article, just let me know. Contact me directly rather than sales for anything else you may need. When you finish and publish your work, send me a link. I often share outside information on our social media accounts. Best of luck on your paper and your project.

Thank You,

Danielle

Danielle Correia

Marketing Coordinator		Epec Engineered Technologies
Office: 508.995.5171 ext1249		Toll Free: 888.995.5171
www.epectec.com		

[41]

Hi Nicholas,

You do have our permission to reference our document but we do require the source to be cited.

Best regards,

Paul

[42]

Yes, you may freely use quotes and pictures from this site in your school reports and technical papers. Cite your source.

[43]

Hi Nicholas,

You do have our permission to reference our document but we do require the source to be cited.

Best regards,

Paul

[44]

Texas Instruments is pleased to provide the information on these pages of the World Wide Web. We encourage you to read and use this information in developing new products.

TI grants permission to download, print copies, store downloaded files on a computer and reference this information in your documents only for your personal and non-commercial use. But remember, TI retains its copyright in all of this information. This means that you may not further display, reproduce, or distribute this information without permission from Texas Instruments. This also means you may not, without our permission, "mirror" this information on your own server, or modify or re-use this information on another system.

TI further grants permission to non-profit, educational institutions (specifically K-12, universities and community colleges) to download, reproduce, display and distribute the information on these pages solely for use in the classroom. This permission is conditioned on not modifying the information, retaining all copyright notices and including on all reproduced information the following credit line: "Courtesy of Texas Instruments". Please send us a note describing your use of this information under the permission granted in this paragraph. Send the note and describe the use according to the request for permission explained below.

[45]

Hello Nicholas,

You are not welcome to use that image for the intended purpose.
Permission is hereby granted.

Good luck with your paper.
Best regards,

Paul

[46]

Texas Instruments is pleased to provide the information on these pages of the World Wide Web. We encourage you to read and use this information in developing new products.

TI grants permission to download, print copies, store downloaded files on a computer and reference this information in your documents only for your personal and non-commercial use. But remember, TI retains its copyright in all of this information. This means that you may not further display, reproduce, or distribute this information without permission from Texas Instruments. This also means you may not, without our permission, "mirror" this information on your own server, or modify or re-use this information on another system.

TI further grants permission to non-profit, educational institutions (specifically K-12, universities and community colleges) to download, reproduce, display and distribute the information on these pages solely for use in the classroom. This permission is conditioned on not modifying the information, retaining all copyright notices and including on all reproduced information the following credit line: "Courtesy of Texas Instruments". Please send us a note describing your use of this information under the permission granted in this paragraph. Send the note and describe the use according to the request for permission explained below.