

# **Low-Shift Raman Microscope**

**Senior Design Project**

**Group 17**



**Brandon Seesahai**

**Chris Beck**

**Kevin Orkis**

**Matthew Aviles**

**Sponsor: Dr. Matthieu Baudelet**

December 6<sup>th</sup> 2016

Fall 2016

# Table of Contents

<b>1</b>	<b>EXECUTIVE SUMMARY .....</b>	<b>1</b>
<b>2</b>	<b>PROJECT DESCRIPTION.....</b>	<b>2</b>
2.1	PROJECT MOTIVATION AND GOALS .....	2
2.2	OBJECTIVE .....	2
2.3	REQUIREMENT SPECIFICATIONS .....	3
2.3.1	<i>Excitation Section .....</i>	<i>3</i>
2.3.2	<i>Microscope .....</i>	<i>4</i>
2.3.3	<i>Spectrometer .....</i>	<i>4</i>
2.3.4	<i>Graphic User Interface (GUI) .....</i>	<i>4</i>
2.3.5	<i>Overall System .....</i>	<i>4</i>
2.3.6	<i>Device Functionality.....</i>	<i>4</i>
2.4	HOUSE OF QUALITY .....	5
<b>3</b>	<b>RESEARCH.....</b>	<b>5</b>
3.1	RELEVANT TECHNOLOGIES .....	5
<b>4</b>	<b>RELATED STANDARDS AND DESIGN CONSTRAINTS .....</b>	<b>6</b>
4.1	ELECTRICAL STANDARDS AND SAFETY .....	6
4.1.1	<i>Power Supply .....</i>	<i>6</i>
4.1.2	<i>Temperature.....</i>	<i>9</i>
4.1.3	<i>Electrical Lab Equipment .....</i>	<i>11</i>
4.2	LASER STANDARDS AND SAFETY .....	11
4.3	OPTIC STANDARDS .....	13
4.4	RAMAN SPECTROSCOPY AND DATABASE.....	15
4.5	DESIGN CONSTRAINTS .....	16
4.5.1	<i>Size Constraints.....</i>	<i>16</i>
4.5.2	<i>Electrical Constraints .....</i>	<i>17</i>
4.5.3	<i>Optical Constraints .....</i>	<i>17</i>
4.5.4	<i>Analysis Constraints.....</i>	<i>18</i>
4.5.5	<i>Safety Constraints.....</i>	<i>18</i>
4.5.6	<i>Auxiliary Constraints.....</i>	<i>18</i>
4.5.7	<i>Software Constraints .....</i>	<i>19</i>
4.5.8	<i>Cost Constraints.....</i>	<i>19</i>
<b>5</b>	<b>PROJECT HARDWARE AND SOFTWARE DETAILS.....</b>	<b>20</b>
5.1	INITIAL DESIGN AND ARCHITECTURE .....	20
5.1.1	<i>Design Overview .....</i>	<i>20</i>
5.1.2	<i>Optical Design.....</i>	<i>22</i>
5.1.2.1	<i>Excitation Section Design .....</i>	<i>22</i>
5.1.2.2	<i>Spectrometer Design.....</i>	<i>27</i>
5.1.3	<i>Electronic Design .....</i>	<i>27</i>
5.1.3.1	<i>PCB/Arduino.....</i>	<i>28</i>
5.1.3.2	<i>Fans .....</i>	<i>28</i>
5.1.3.3	<i>Interlock/Solenoid.....</i>	<i>28</i>
5.1.3.4	<i>Back Light .....</i>	<i>29</i>

5.1.3.5	Camera .....	29
5.1.4	<i>Microscope</i> .....	29
5.1.5	<i>Box Design</i> .....	29
5.2	EXCITATION SYSTEM .....	30
5.2.1	<i>Laser</i> .....	30
5.2.1.1	Laser Theory and Relevant Concepts .....	30
5.2.1.2	Laser Parts Comparison and Specifications .....	36
5.2.1.3	Photodiode & Circuit Analysis .....	38
5.2.2	<i>Volume Bragg Gratings (VBG)</i> .....	40
5.2.2.1	VBG Theory, Concepts, and Parts .....	40
5.2.3	<i>Photodiode</i> .....	42
5.2.3.1	Light Detectors and Photodiode Theory .....	42
5.2.3.2	Optical Power Sensing and Calibration .....	44
5.2.3.3	Photodiode Parts Comparison and Specifications .....	47
5.3	MICROSCOPE .....	49
5.3.1	<i>Microscope Specs</i> .....	49
5.3.2	<i>Microscope and System Integration</i> .....	49
5.3.3	<i>Microscope Camera</i> .....	50
5.3.4	<i>Microscope Beam Splitter</i> .....	53
5.3.5	<i>Periscope</i> .....	55
5.4	SPECTROMETER .....	56
5.4.1	<i>Spectrometer Overview</i> .....	56
5.4.2	<i>Design Considerations</i> .....	56
5.4.2.1	Fourier Transform vs. Dispersion Spectrometers .....	56
5.4.2.2	Monochromator vs. Spectrometer .....	57
5.4.3	<i>Design Overview</i> .....	58
5.4.4	<i>Detector</i> .....	60
5.4.4.1	Detector Specifications .....	60
5.4.4.2	Detector Integration .....	60
5.4.5	<i>Grating</i> .....	62
5.4.6	<i>Mirror</i> .....	63
5.4.7	<i>Spot Size Magnification</i> .....	64
5.4.8	<i>Notch Filter</i> .....	65
5.4.9	<i>Design Summary</i> .....	66
5.5	THE MICROCONTROLLER .....	67
5.5.1	<i>Microcontroller Theory</i> .....	67
5.5.2	<i>Microcontroller Comparisons and Specifications</i> .....	71
5.5.2.1	Texas Instruments and the “MSP430” .....	71
5.5.3	<i>“The Raspberry Pi”</i> .....	74
5.6	ARDUINO SPECIFICATIONS, FEATURES, AND SCHEMATIC .....	76
5.6.1	<i>Power theory, the external &amp; internal power</i> .....	76
5.6.2	<i>Specifications, Features, and Schematic</i> .....	76
5.7	LASER POWER CONTROL .....	78
5.7.1	<i>Laser Power Control Theory</i> .....	78
5.7.2	<i>Specifications and Pulse Width Modulation</i> .....	78
5.7.3	<i>Circuit Analysis</i> .....	80
5.7.3.1	Power Control Utilization & Parts .....	80
5.8	TEMPERATURES SENSING & CONTROL .....	85
5.8.1	<i>Temperatures Sensing &amp; Control Specifications &amp; Purpose</i> .....	85
5.8.2	<i>Temperature Sensors</i> .....	87

5.8.2.1	Analog vs. Digital temperature sensors.....	87
5.8.2.2	Comparison & Justification .....	91
5.8.2.3	Temperatures Control options .....	93
5.8.3	<i>Temperatures Control Options</i> .....	96
5.8.3.1	Fan specifications & other options.....	96
5.8.4	<i>Circuit Analysis &amp; schematic</i> .....	97
5.9	LASER BLOCKING .....	102
5.9.1	<i>Laser Blocking Specifications and Purpose</i> .....	102
5.9.2	<i>Laser Blocking Parts</i> .....	103
5.9.2.1	DC Motors .....	103
5.9.2.2	Stepper Motors .....	104
5.9.2.3	Actuators.....	104
5.9.2.4	Solenoids .....	105
5.9.3	<i>Solenoid specifications &amp; justification</i> .....	106
5.9.3.1	Circuit Analysis & schematic.....	106
5.10	BACKLIGHT CONTROL.....	109
5.10.1	<i>Backlight Use Theory and Purpose</i> .....	109
5.10.2	<i>Circuit Analysis and Schematic</i> .....	110
5.11	SOFTWARE DESIGN .....	112
5.11.1	<i>Software Requirements</i> .....	114
5.11.1.2	Hardware/API Comparison .....	115
5.11.1.3	Display Section .....	120
5.11.1.4	Controls.....	122
5.11.1.5	Back End Code.....	122
5.11.2	<i>Design Phase</i> .....	123
5.11.2.2	Display Data .....	126
5.11.2.3	Controls.....	128
5.11.2.4	Back End Code.....	129
5.11.3	<i>Building Phase</i> .....	131
5.11.3.1	Display Data .....	131
5.11.3.2	Back End.....	133
5.11.4	<i>Testing</i> .....	134
5.11.4.1	Types of Tests.....	134
<b>6</b>	<b>PROJECT PROTOTYPE CONSTRUCTION.....</b>	<b>135</b>
6.1	INTEGRATED SCHEMATIC.....	135
6.2	BREADBOARD TESTING .....	136
<b>7</b>	<b>PROJECT PROTOTYPE TESTING PLAN .....</b>	<b>137</b>
7.1	HARDWARE TEST ENVIRONMENT .....	137
7.2	HARDWARE SPECIFIC TESTING .....	137
7.2.1	<i>Excitation System Testing</i> .....	137
7.2.2	<i>Detector Calibration</i> .....	138
7.3	SOFTWARE SPECIFIC TESTING .....	138
<b>8</b>	<b>ADMINISTRATIVE CONTENT.....</b>	<b>140</b>
8.1	MILESTONE DISCUSSION .....	140
8.2	BUDGET AND FINANCE DISCUSSIONS .....	142
<b>9</b>	<b>PROJECT SUMMARY AND CONCLUSIONS.....</b>	<b>144</b>
<b>10</b>	<b>REFERENCES.....</b>	<b>145</b>

<b>11</b>	<b>APPENDICES.....</b>	<b>148</b>
11.1	APPENDIX A- COPYRIGHT PERMISSIONS .....	148

## 1 Executive Summary

Spectroscopy is a branch of science that involves the creation and collection of a spectrum that acts as the "fingerprint" of a sample. Raman spectroscopy is a spectroscopic technique used to obtain a spectrum induced from molecular vibrations, which can be used for sample identification and quantification. When a laser is incident on a sample, Rayleigh scattering or elastic scattering is a dominant process that is the same wavelength as the excitation source. However, inelastic scattering is of interest in Raman spectroscopy and is caused when the vibrational states of a molecule causes the scattered wavelength to shift from the excitation wavelength. A Raman spectrum shows the Stokes and Anti-stokes scattering or shifts from the excitation wavelength. The spectrum is plotted in intensity of the light signal vs. wavenumber ( $\text{cm}^{-3}$ ).

A microscope is a convenient device used to observe a sample with high-resolution imaging. Furthermore, sending a laser light through the objective lens of the microscope allows for strong focusing of the laser light onto a sample. Utilizing the strong focusing of a microscope can be useful for Raman spectroscopy because a strong excitation signal can be created. Having a strong excitation signal allows for particular optical signatures to be detected that can serve for distinguishable sample characterization and identification. Our customer and sponsor, Dr. Matthieu Baudelet, wants a Raman spectroscopy setup to be built as an attachment for his microscope to detect low Raman shifts.

The excitation section of the project includes the laser, volume bragg grating (VGBs), photodiode, and focusing optics. For the excitation component of the project, the laser power must be controlled and measured. In terms of safety, a beam blocker has to be utilized to block the laser beam whenever a sample is being placed onto the microscope sampling stage. Additionally, the laser needs have a safety switch to turn it off in case of emergency. Temperature sensors and fans will also be placed in the excitation section to give a temperature measurement and keep air following through the system respectively, thereby preventing a build up of heat. The detection section is a spectrometer that involves using optics (filters, mirrors, lenses, and grating) to guide light to a detector. The detector is used in a circuit to convert the Raman light signal to an electric signal for a computer to display the results. An overall user interface should show the temperature of the system, the Raman spectrum, a camera feed of the sample, and the laser power. The user interface must also allow for laser power control.

In summary, this project involves a laser and filters to create a laser signal with a narrow line width for the microscope. The Raman scattering created from the narrow line width laser is the output light signal that will be analyzed using a spectrometer. The excitation and spectrometer serves as the attachment for the microscope and must be rugged, compact, affordable, deliverable for high-resolution spectra, and controlled from a user interface.

## 2 Project Description

### 2.1 Project Motivation and Goals

A standard microscope allows for high magnification visualization of a sample, and coupling this high-resolution spatial imaging with a laser allows for a laser beam to be focused to several micrometers in diameter. The result of the objective lenses of microscopes focusing the laser beam to several micrometers in diameter allows for the resulting irradiance to be much higher than achieved in conventional Raman setups. Having a higher irradiance allows for high intensity Raman signal shifts that can be used for sample identification. Furthermore, focusing a laser beam to small sections of an image allows for Raman image mapping. A Raman spectral image (or mapping) is a method for generating detailed chemical images based on a sample's Raman spectrum. Since a microscope can focus a laser beam to a small spot size in the order of microns, a complete spectrum can be acquired at each pixel of a sample's image. The Raman spectrum at each spot can then be used to generate a false color image based on material composition. For example, a Raman image that is  $0.6 \times 2.4 \text{ mm}^2$  of a pharmaceutical tablet can show the distribution of aspirin, paracetamol, caffeine, and cellulose. A Raman spectrum can yield the following information

- Raman peak intensity provides images of material concentration and distribution.
- Raman peak position yields images of molecular structure, phase, and material stress/strain.
- Raman peak width yields images of crystallinity and phase.

A professor of chemistry named Dr. Matthieu Baudelet has approached this senior design group and he currently has a standard microscope, a laser, and filters and wants a Raman Microscope system to be built in his lab. His goal for his Raman system is to perform Raman images and to apply Raman spectroscopy for forensic applications. Raman spectroscopy has advantages in forensics because it allows for non-destructive and in-situ identification of controlled drugs and narcotics, non-destructive and in-situ analysis of different black inks, identification of explosive materials, and identification of a sequence of non-intersecting lines for forged document investigation.

Creating a Raman microscope system to perform Raman imaging requires high precision stage movement, Raman spectrum peak analysis and identification, and high quality imaging processing, which is outside the scope of the senior design project. With the motivation and goal that Dr. Matthieu has in mind for the Raman microscope system, the senior design project is focused mainly on getting the system to work to eventually achieve the overall goal of Raman mapping and forensic science applications. This system must have a working excitation section, a spectrometer or detection section for low-shift signals, a safety feature, and an understandable user interface so that chemistry or forensic majors can efficiently use the system.

### 2.2 Objective

The objective of this senior design project is to design and make a Raman spectroscopy setup that is incorporated with a standard microscope. In other words, a microscope attachment has to be engineered to be suitable with the provided microscope. The attachment must be enclosed for safety reasons and be rugged and compact. Inside

the attachment includes an excitation and spectrometer section. The objective for the excitation section is to guide and align the laser toward the microscope with a narrow laser line width because this will allow for low-shift Raman signals to be excited. A narrow laser line width is achieved through optical filters that is included in the alignment as well. The laser power must be determined and controlled in the excitation section, and a beam blocker has to be utilized to block the beam when samples are being placed on the microscope. Temperature control has to be utilized so that the laser does not heat up to the point where the environment around the laser is affected. For instance, the optical filters can be affected by a hot environment and change the alignment and filtering of the laser beam. Overall, the object of the excitation section is to have a good optical alignment into the microscope, by about to control and measure laser power, and maintain a temperature controlled environment.

The spectrometer section must be able to detect the low-shift signals. Optics must be aligned in the spectrometer section to guide the Raman shift signals to the detector. For instance, the Raman signal induced from the laser must be successfully captured out of the microscope and filtered so that the laser line is blocked. From there, a spectrometer design is implemented to guide and dissect the output Raman signal into its wavelength components. The wavelength components of the Raman signal has to be successfully aligned onto a detector with a high pixel resolution and converted into an electrical signal that can be read through software.

The objective of the electronic design is to implement safety features in the system, such as a beam blocker when a sample is placed onto the microscope, to control and measure laser power, measure the temperature of the system, and detect the output light signal. Software must be utilized to view the output signals generated from the system such as laser power, temperature, sample image, and Raman spectrum. A summary of objectives is shown below.

- Design an optical alignment for a narrow line width laser signal that can be input into a microscope to induce Raman scattering.
- Design a spectrometer so that the output Raman signal can be affectively captured out of the microscope, filtered, and guided to a high resolution detector.
- Design electronic circuits to install safety features, control and measure laser power, capture and convert the Raman signal into an electrical signal, and maintain temperature control.
- Design a user interface that is easy to use for someone to read and control laser power, see an image of the laser hitting the sample, read the temperature of the excitation section of the system, and see a Raman spectrum.

## 2.3 Requirement Specifications

### 2.3.1 Excitation Section

- Laser:  $\lambda = 785 \text{ nm}$
- Excitation Signal with a narrow line width
- Filters: 2 Volume Bragg Gratings (VBG)
- Power Sensor: Detect and Measure Power of  $\lambda = 785 \text{ nm}$
- Laser Power must be controlled



- Temperature of excitation section needs to be constant for the VGBs

#### 2.3.2 Microscope

- Stage movement x,y,z
- Imaging device for sample
- Alignment of Raman excitation and imaging should work for any available microscope objective.
- Safety (Class 1)

#### 2.3.3 Spectrometer

- Filter out laser line  $\lambda = 785 \text{ nm}$
- Resolve Stokes and Anti-stokes Raman Scattering
- Spectral Range: Detect low-shift Stokes and Anti-stokes ( $\pm 200 \text{ cm}^{-1}$ )
- Resolution  $< 5 \text{ cm}^{-1}$
- Detector for  $\lambda \approx 785 \text{ nm}$

#### 2.3.4 Graphic User Interface (GUI)

- Display temperature
- Display/Control Laser Power
- Display live feed of sample image
- Display spectral results
- Go button

#### 2.3.5 Overall System

- Box to enclose excitation, spectrometer, and microscope section: Rugged and Compact
- Class 1
- Safety Feature

#### 2.3.6 Device Functionality

The entire system, which includes the excitation, spectrometer, and microscope sections, must be rugged, compact, enclosed in a box, and achieve class 1 restriction. The following defines each device functionality.

**Laser** - Source of excitation

**Volume Bragg Grating (VBG)** - Functions as a filter for the laser. The spectrum of the laser beam is filtered using the VBG so that a narrow line width is achieved.

**Temperature Sensor** - Monitor temperature within the system.

**Laser Power Sensor** - Measures the power of the laser beam.

**Dispersive Optic** - Disperses the Raman scattering signal to be captured by a detector.

**Detector** - Reads the Raman scattering signal so that it can be processed and displayed in a spectrum.

**Microcontroller** - Controls various aspects of each section, which includes temperature sensing and control, laser power sensing and control, and spectral acquisition.

## 2.4 House of Quality

			Engineering Requirements							
			Laser Power	Filtering	Spectral Range	Resolution	Sensitivity	Ease of Implementation	Cost	
			+	+	+	+	+	+	-	
Marketing Requirements	Install Ease	+						↑↑	↓	
	Reliability	+	↑↑	↑	↓	↑	↓		↓	
	Portability	+						↑↑	↓	
	Ease of Use	+					↑	↓	↓	
	High Performance	+	↑	↑	↑	↑	↑	↓	↓	
	Image Quality	+		↑			↑↑	↑↑	↑	↓
	Repeatability	+					↑↑	↑↑	↑↑	↓↓
	Cost	-	↓	↓↓	↓	↓	↓	↓	↑↑	↑↑
	Target for Engineering Requirements		<100 mW	< .12nm FWHM	+200 cm <sup>-1</sup>	< 5 cm <sup>-1</sup>	N/A	N/A		< \$10,000

## 3 Research

### 3.1 Relevant Technologies

Raman shifts were discovered almost a century ago. Due to the low amount of Raman scattering, however, Raman spectrometers were very difficult to use. In order to accurately use Raman scattering for spectroscopy, a monochromatic light source must be used. It wasn't until the advent of the laser that a monochromatic source of sufficient intensity was developed.

Raman spectroscopy is now a common analytic technique. It provides many advantages over other types of analysis; for example, Raman spectroscopy does not damage the sample being analyzed, which is incredibly useful in forensics and other analytic labs.

The Raman spectrometer being designed is intended to work with low-shift Raman, measuring both the Stokes and Anti-Stokes scattering. We looked at several Raman spectrometers commercially available to get an understanding of what specs our spectrometer should have.

There are a good number and variety of Raman spectrometers commercially available, though we focused mostly on Raman microscopes, as opposed to other types of spectrometers. One example is the Horiba XploRA One. This spectrometer is able to quickly and accurately analyze the entire Raman spectrum in a single measurement.

However, this spectrometer does not offer analytic capabilities in the low-shift range, instead only focusing on larger shifts, known as the fingerprint region.

Another company, Renishaw, has developed a Raman spectrometer that offers analysis in both the fingerprint region as well as the low-shift region. However, the Renishaw spectrometer only measures Stokes scattering. It does not have the capabilities of measuring the Anti-Stokes scattering.

The only Raman microscope commercially available that is able to measure both Stokes and Anti-Stokes low-shift Raman is THz-Raman Spectrometer from Ondax. This spectrometer has a spectral range from  $-200 \text{ cm}^{-1}$  to  $2200 \text{ cm}^{-1}$ , meaning that it includes both the low-shift range as well as the fingerprint region.

The Ondax spectrometer also has a spectral resolution of  $2.5 \text{ cm}^{-1}$  to  $4 \text{ cm}^{-1}$ . Ideally, our spectrometer should be able to have a higher resolution, since the spectral range of our spectrometer is much lower.

## **4 Related Standards and Design Constraints**

### **4.1 Electrical Standards and Safety**

#### **4.1.1 Power Supply**

For the project, different power supplies will be used for different parts of the system. This leads to finding the standards available for power supplies so that the project will meet powering requirements for all electronic parts. By meeting power supply standards, this allows the project to meet the power supply specifications for use of parts. By accordance of the standards and standard definitions defined by the article Supply Safety Standards, Agencies and Marks, by CUI INC ®, there are 3 defined classifications of power supplies. These are defined as Class I, Class II, and Class III. These standards come from a defined and created from The International Electrotechnical Commission (IE) along with the International Organization and Standardization (ISO). IEC60950-1, Safety of Information Technology Equipment, highlights the importance of standards with its first and second amendments. This article applies to power supplies rated at voltages of 600 and below. Within the article are circuit definitions which are used to understand the full scope of defining and understanding power supply standards. The figure below shows the Circuit Definitions provided by the article.

## Circuit Definitions

Hazardous Voltage	<i>Any voltage exceeding 42.2 Vac peak or 60 Vdc without a limited current circuit.</i>
Extra-Low Voltage (ELV)	<i>A voltage in a secondary circuit not exceeding 42.4 Vac peak or 60 Vdc, the circuit being separated from hazardous voltage by at least basic insulation.</i>
Safety Extra-Low Voltage (SELV) Circuit	<p><i>A secondary circuit that cannot reach a hazardous voltage between any two accessible parts or an accessible part and protective earth under normal operation or while experiencing a single fault. In the event of a single fault condition [insulation or component failure] the voltage in accessible parts of SELV circuits shall not exceed 42.4 Vac peak or 60 Vdc for longer than 200 ms. An absolute limit of 71 Vac peak or 120 Vdc must not be exceeded.</i></p> <p><i>SELV circuits must be separated from hazardous voltages, e.g. primary circuits, by two levels of protection, which may be double insulation, or basic insulation combined with an earthed conductive barrier.</i></p> <p><i>SELV secondaries are considered safe for operator access. Circuits fed by SELV power supply outputs do not require extensive safety testing or creepage and clearance evaluations.</i></p>
Limited Current Circuits	<p><i>These circuits may be accessible even though voltages are in excess of SELV requirements. A limited current circuit is designed to ensure that under a fault condition, the current that can be drawn is not hazardous. Limits are detailed as follows:</i></p> <ul style="list-style-type: none"> <li><i>• For frequencies &lt; 1 kHz the steady state current drawn shall not exceed 0.7 mA peak ac or 2 mA dc. For frequencies above 1 kHz the limit of 0.7 mA is multiplied by the frequency in kHz but shall not exceed 70 mA.</i></li> <li><i>• For accessible parts not exceeding 450 Vac peak or 450 Vdc, the maximum circuit capacitance allowed is 0.1 µF.</i></li> <li><i>• For accessible parts not exceeding 1500 Vac peak or 1500 Vdc the maximum stored charge allowed is 45 µC and the available energy shall not be above 350 mJ.</i></li> </ul> <p><i>To qualify for limited current status the circuit must also have the same segregation rules as SELV circuits.</i></p>

page | 3

**Figure 1: Circuit Definitions (pending approval from CUI INC ®)**

1. Class I: A piece of equipment shall receive basic insulation and protective earth grounding to achieve protection from electric shock. To achieve this, the conductive parts of the equipment that could be deemed as hazardous must be connected to a protective earth conductor in the event basic insulation failure has occurred.
2. Class II: A piece of equipment that shall receive double insulation or reinforced insulation. Because of the double layer of protection, this allows the piece of equipment to no longer be required to be grounded.
3. Class III: A piece of equipment that can operate from a Safety Extra Low Voltage (SLEV) supply circuit. This means that it can be protected from electric shock which allows protection from hazardous voltage to be generated within the equipment.

Within the document, there is also a standard defined for other aspects of other electrical equipment. These equipment breakdowns are in relation to medical equipment, audio and video, and other defined electrical equipment within the document. Because this project needs multiple power supplies, a breakdown of the equipment used that needs a power supply is as follows:

1. Laser Power: The laser will be powered from a 5V DC power supply that is supplied from a AC to DC wall outlet. Because of this the following will occur for the group to fully achieve the power standards:

- a. Use a power supply that is rated Class III.
  - b. Use a power supply that is supplies the correct voltage to the laser.
  - c. Make sure the microcontroller being used allows for voltage transitioning as needed.
2. Fan Motor Power: The fan motor that is used to regulate temperature control must be within a preferred range of 5V and meet the requirements specified within its design constraints. Because of this the following will occur for the group to fully achieve the power standards:
  - a. Use a power supply that is rated Class III.
  - b. Use a power supply that is supplies the correct voltage to the fan motor.
  - c. Make sure the microcontroller being used allows for voltage transitioning as needed.
  - d. Allows the fan to ramp up and down without burning out as needed.
3. Backlight Power: Backlight that is used for the camera as well as for the sample on the sample stage must be powered by a 24V power supply from a AC to DC switching power supply connected via a wall outlet. This is required because the design constraints of the backlight probe being used has a design constraint of 24V, 1.5A power source for backlighting to occur. Because of this the following will occur for the group to fully achieve the power standards:
  - a. Use a power supply that is rated Class III.
  - b. Use a power supply that is supplies the correct voltage to the backlight.
  - c. Make sure the microcontroller being used allows for voltage transitioning as needed.
  - d. Allows the backlight to switch on and off as needed without a slow rise and settling time.
4. Microcontroller standards: Microcontroller that is used must adhere to the electrical design standards specified by its design standard constraints. The allowed voltage as an external power source for a given microcontroller like an Arduino should be within the range given by the specification sheet. The Arduino Uno that will be used in this project must adhere to an external voltage source of 6-20 volts with a preferred range of 7-12 Volts. Because of this the following will occur for the group to fully achieve the power standards:
  - a. Use a power supply that is rated Class III.
  - b. Use a power supply that is supplies the correct voltage to the microcontroller.
  - c. Make sure the microcontroller being used is within the design power constraints.
5. Solenoid Power: The solenoid that is used to allow laser blocking control must be within a preferred range of 5V and meet the requirements specified within its design constraints. Because of this the following will occur for the group to fully achieve the power standards:
  - a. Use a power supply that is rated Class III.
  - b. Use a power supply that is supplies the correct voltage to the solenoid.
  - c. Make sure the microcontroller being used allows for voltage transitioning as needed to power on or off the solenoid.

Failure to adhere to any power constraints specified by these design standards go against safety regulations for the use of electrical equipment which can cause hazardous damage to not only the equipment, but also to the user. Failure to comply could result in the failure to uphold lab safety standards and other specified standards within the electrical standard section.

#### 4.1.2 Temperature

For this project, temperature will play a significant role not only for the ambient temperature of the lab, but for the actual temperature of the lab equipment. Temperature sensors which will be connected to fans will regulate the temperature as within desired temperature constraints of most of the components within the project cooled at room temperature. Because the standards need to be met for rating electrical equipment in relation to defined temperatures, in accordance to IEEE Std 1- 2000 - IEEE Recommended Practice - General Principles for Temperature Limits in the Rating of Electrical Equipment and for the Evaluation of Electrical Insulation, Section 4 highlights the general concepts for limiting temperature. To understand the standards defined in this article, the temperature definitions related to electrical equipment must be understood. *Figure 2* highlights the temperature equipment definitions below. Equipment must have a satisfactory life under normal operating conditions. In the case of emergency higher temperatures limits must be established when peak load operation occurs. In temperature limiting the following must occur stated from Section 4 of IEEE Std 1- 2000:

1. “Ambient temperature is unlikely to be maintained at its minimum or maximum value for long periods.”
2. “Load cycles may consist of periods during which the load may be above or below rated.”

(source: from Section 4 of IEEE Std 1- 2000 under General Concepts)

Section 4.1 of IEEE Std 1-2000 refers to temperature measurements and the standards regarding measuring temperature. These standards must adhere to electrical equipment that can rise to a max. The max temperature attained by a part must be measured directly. Temperature must be less than the difference between the temperature in Table 1 from IEEE Std 1-2000.

**Table 1: Suggested values of observable temperature rise, °C**

30	35	40	45	50	55	60	65	70	75	80	90
100	115	120	130	140	150	160	180	200	220	240	

From IEEE 1-200 under Temperature Measurement states that “The method of measurement to be used for determining the temperature rise of insulated parts should be prescribed in the standards for the equipment. When specifying permissible temperature rises and measurement methods in standards for electric equipment, it is generally useful to consider construction factors, such as method of cooling, although these factors are normally not included in the standard proper” (Source from IEEE 1-200 under Temperature Measurement).

### 3.2 Definitions related to electric equipment

ambient:

The medium (for example, air, gas, liquid, or earth) in which electric equipment operates.

ambient temperature:

The temperature of the ambient medium.

hottest-spot temperature (hot spot):

The highest temperature attained in any part of the electrical insulation system (EIS) of electric equipment. (Difficulties in its determination are encountered. See [Clause 4](#).)

hottest-spot temperature allowance:

The designated difference between the hottest-spot temperature and the observable insulation temperature. Suggested values are commonly used in standards. (The value depends on many factors, such as size and design of the equipment, and should be determined by thermal analysis and/or calculations based on fundamental loss and heat transfer principles and substantiated by testing on prototype equipment or full-size models).

limiting ambient temperature:

The highest (or lowest) ambient temperature at which electric equipment is expected to give specified performance under specified conditions, for example, rated load.

limiting hottest-spot temperature:

The highest temperature attained in any part of the electrical insulation system (EIS) of electric equipment, which is operating under specified conditions, usually at maximum rating and the upper limiting ambient temperature.

observable insulation temperature:

The temperature of the electrical insulation system (EIS) in electric equipment, which is measured in a specified way, for example, with a thermometer, embedded thermocouple, or resistance detector or by winding resistance or other suitable procedure.

observable temperature rise:

The difference between the observable temperature of an electrical insulation system (EIS) and the ambient temperature.

**Figure 2: IEEE Std 1- 2000 - Definitions related to Electric Equipment (Permission from UCF, IEEE Database)**

Because of these standard, this detects that temperature occurs for the use of the equipment in this project must adhere to not only the design specifications of the parts chosen in the project (which should already adhere to these design specifications by IEEE) but also to the design of the structure that will store the parts that are being utilized. This means that the ambient temperature that needs to be regulated within the structure needs to stay within the standards defined by this article. This means that the temperature sensors being chosen must adhere to the use of the allotted range. Failure to uphold these standards could result in too much heat being generated within the structure and could violate safety hazards for not only the equipment being used and potentially destroyed, but also for the users and users in the vicinity. These standards will be upheld

by the design specifications and requirements to ensure life safety is deemed satisfactory and deemed fit for development and manufacturing.

#### 4.1.3 Electrical Lab Equipment

Electrical lab equipment and electrical lab safety is standard that must be followed. Equipment existing in lab spaces must adhere to certain standards defined by UL61010-1 which is sourced UL LLC © defined from International Electro Technical Commission by article IEC 61010. This indicates that the equipment used in the lab to test other devices and components must adhere to these standards. This indicates that all electrical equipment used in the lab which is used for testing, measuring, with electrical properties such as transducers, desktop power supplies, etc. must adhere to this standard. This standard also applies to computers and other processors which are used in the lab. This equipment is allowed to be used in labs but also can be used in other areas like homes but must be inspected and electrically safe prior to use. This standard applies to the following equipment:

- A. To be employed in accordance with ANSI/NFPA 70, National Electrical Code® (NEC);
- B. Designed to comply with the general requirements of CAN/CSA C22.2 No. 0 and to be installed in accordance with the Canadian Electrical Code (CEC), Part I, CSA C22.1; or
- C. Both (a) and (b).

Another purpose of this standard is to ensure protection against types of hazards. The electrical equipment being used in the lab must protection against hazards that could create problems within the lab testing area. Equipment should be protected and not misused. Because of this, these standards must be enforced and uphold. The follow are examples of hazards that this standard enforces:

- A. electric shock or burn (see Clause 6);
- B. mechanical HAZARDS (see Clauses 7 and 8);
- C. spread of fire from the equipment (see Clause 9);
- D. excessive temperature (see Clause 10);
- E. effects of fluids and fluid pressure (see Clause 11);
- F. effects of radiation, including lasers sources, and sonic and ultrasonic pressure (see Clause 12); liberated gases, explosion and implosion (see Clause 13).

#### 4.2 Laser Standards and Safety

The American National Standards Institute (ANSI) is an organization for which expert volunteers participate on committees to set industry consensus standards in various fields. The ANSI Z136 committee has published standards specific to the laser field. The current version of the laser standards document is the called ANSI Z136.1-2007, which is a revised version of the standards from ANSI Z136.1-2000. The standard provides recommendations for the safe use of lasers and laser systems that operate at wavelengths between 180 nm to  $10^6$  nm. A practical means for accomplishing this is first to (1) classify laser and laser systems according to their relative hazards and then to (2) specify appropriate controls for each classification. The basis of the hazard classification in



standards is the ability of the laser beam to cause biological damage to the eye or skin during use. The seven classes of lasers are discussed below.

A class 1 laser system is considered to be incapable of producing damaging radiation levels during operation and is exempted from any control measures or other forms of surveillance. A class 1M laser system is considered to be incapable of producing hazardous exposure conditions during normal operation unless the human eye views the laser beam with an optical instrument. Control measures are not used for class 1M laser systems other than to prevent potentially hazardous optical viewing of the laser beam. Other forms of surveillance are exempted as well. A class 2 and class 2M laser system emits in the visible portion of the electromagnetic spectrum (400 nm to 700 nm) and eye protection is not required. The beam from a class 2 or class 2M laser should not be viewed with an optical instrument. A class 3 laser has two subclasses, which are class 3R and class 3B. Class 3 lasers at medium power can be hazardous under direct and specular reflection viewing condition and is not a diffuse reflection or fire hazard. The probability of an eye injury from a Class 3R and Class 3B laser are small. A class 4 laser system at high power is a hazard to the eye and skin from the direct beam and may pose a diffuse reflection or fire hazard. Class 4 laser can also produce laser generated air contaminants (LGAC) and hazardous plasma radiation and eliminates the need for quantitative analysis of hazard potential, or use of Maximum Permissible Exposures (MPEs).

**Table 2: Requirements by Laser Classification**

Class	Procedural & Administrative Controls	Training	Medical Surveillance	Laser Safety Officer (LSO)
1	Not Required	Not Required	Not Required	Not Required
1M	Required	Application Dependent (2)	Application Dependent (2)	Application Dependent (2)
2	Not Required (1)	Not Required (1)	Not Required	Not Required
2M	Required	Application Dependent (2)	Application Dependent (2)	Application Dependent (2)
3R	Not Required (1)	Not Required (1)	Not Required	Not Required (1)
3B	Required	Required	Suggested	Required
4	Required	Required	Suggested	Required

During maintenance and service the classification associated with the maximum of laser radiation will be used to determine the applicable control measures. In other words, the reason why the table above has the word "application dependent" is because certain requirements must be enforced depending on the application the laser class is used for. Having a (1) near the word "not required" means that a requirement is not enforced except for conditions of intentional intrabeam exposure applications. Having a (2) near the word "Application dependent" means that certain uses of class 1M or 2M lasers or laser systems that exceed Class 1 or Class 2 may require hazard evaluation and manufacturer's information.

For laser safety programs, management (employer) has the fundamental responsibility for the assurance of the safe use of lasers owned and operated in facilities

under its control. Management should also establish and maintain an adequate program for the control of laser hazards. Laser Safety programs established must include the following provisions.

1. A Laser Safety Officer (LSO) is needed with the authority and responsibility to evaluate and control laser hazards, implement control measures, and monitor and enforce compliance with required standards and regulations. The LSO either performs the stated tasks or assures that the task is performed by another qualified individual.
2. Authorized personnel should be educated through training programs in the safe use of lasers, laser systems, and the assessment and control of laser hazards for laser classes greater than Class 1.
3. Incident investigation that involves reporting of alleged accidents to the LSO, and preparation of action plans for the prevention of future accidents .
4. A medical examination and medical surveillance program.

**Table 3: Control Measures for the Seven Laser Classes**

Engineering Control Measures	Classification						
	1	1M	2	2M	3R	3B	4
Protective Barriers and Curtains	No	No	No	No	No	Yes	Yes
Laser Warning Signs	No	No	No	No	Maybe	Yes	Yes
Indoor Laser Controlled Area	No	Maybe	No	Maybe	No	Yes	Yes
Protective Eye Wear	No	No	No	No	No	Maybe	Yes

#### 4.3 Optic Standards

The largest force in the world today for standardization is the International Organization for Standardization (ISO), which is based in Geneva, Switzerland. The ISO has around 165 member nations and chairs, more than 2700 technical committees, subcommittees, and working groups. Formed in 1978, the standards for optics and photonics are developed by Technical Committee (TC) 172. In other words, the ISO/TC 172 works on the standardization of terminology, requirements, interfaces, and test methods in the field of optics and photonics. The US representation is administered by the Optics and Electro-Optics Standards Council (OEOSC) under the guidance of the American National Standards Institute (ANSI). OEOSC also manages the American Standards Committee for Optics (ASC OP), which is responsible for all American

national standards for optics and electro-optics except for those of the ophthalmic industry.

OEOSC is a standards council made up of companies, corporations, organizations, institutions, and individuals whose main purpose is to create standardization in the optic industry in the US. OEOSC was formed in 1996 as a merger between the standards writing bodies of SPIE, OSA, APOMA, NAPM, and Eastman Kodak. Since 1996, OEOSC has grown to more than 70 members and is now an important force behind national and international standards for optics. At the international level, OEOSC oversees all participation in TC 172 and has participated in the development or revision of some of the most important standards in the optics industry, including international drawing standard (ISO 10110) and the standards for optical coating (ISO 9211). The table below shows some of the domestic (ASC OP) and international (ISO) standards for optics.

**Table 4: Index of some American National and ISO standards.**

Field of Application	ASC OP Drawings	ASC OP Measurement	ISO TC172 Drawings	ISO TC172 Measurement
Drawing Format	OP 1.0110-1 OP 1.0110-10	-	ISO 10110-1 ISO 10110-10	-
Scratch & Dig	OP1 .002	OP1.002	ISO 10110-7	ISO14997
Coatings	OP 1.0110-9	OP1.9211	ISO 10110-9	ISO 9211
Transmitted Wavefront	OP 1.110-14	-	ISO 10110-14	ISO9334
Aspheres	OP 1.110-12	OP1.006	ISO 10110-12	-

In 2015, the United States joined the international community by adopting a version of ISO 10110 as the American National Standard for optics drawings. In summary, the ISO 10110 series of International Standards specifies the presentation of design and functional requirements for optical elements and systems in technical drawings used for manufacturing and inspection. A description of some of the sections are given below, including the sections mentioned in the table above.

- ISO 10110-1 specifies the presentation in drawings of the characteristics, especially the tolerances, of optical elements and systems.
- ISO 10110-5 specifies rules for indicating the tolerance for surface form deviation.
- ISO 10110-7 specifies the indication of the level of acceptability of surface imperfections within the effective aperture of individual optical elements and optical assemblies. These include localized surface imperfections, edge chips, and long scratches. This section also applies to transmitting and reflecting surfaces of finished optical elements, whether or not they are coated.
- ISO 10110-9 specifies rules for indicating the treatments and coatings that are applied to optical surfaces for functional and/or protective purposes.

- ISO 10110-12 specifies rules for presentation, dimensioning, and tolerance of optically effective surface of aspheric form.
- ISO 10110-14 gives rules for the indication of the permissible deformation of a wavefront transmitted through or, in the case of reflective optics, reflected from an optical element or assembly. The deformation of the wavefront refers to its departure from the desired shape.

#### 4.4 Raman Spectroscopy and Database

Raman spectroscopy provides the vibrational fingerprint of a sample. Every molecule has vibrational states that causes an incident monochromatic light to scatter at a different wavelength, thus providing the Raman spectral signature. The shifts in wavelengths are identified as the stokes and anti-stokes. There are databases for Raman spectra that can be looked at to verify if a given spectrum matches a particular molecule or sample. The Raman spectra provided from these databases can be used as a standard because samples will always have its own spectral signature that cannot to be changed. Furthermore, these databases can be used to calibrate a spectrum. For instance, if a spectrum is obtain from a solid silicon sample using the Raman system developed in this senior design project, the databases can be used to calibrated the spectrum to make sure that the spectral lines are appearing at the right wavenumber. The RRUFF database presents a complete set of high quality spectral data from well-characterized minerals. This database provides a standard for mineralogists, geoscientists, gemologists, and the general public for the identification of minerals both on earth and for planetary exploration. Pictures of the sample of interest are also provided. Software is also given from the RRUFF website called CrystalSleuth ,which is a windows-based software that allows for investigation and analysis of spectra from a dataset. Utilizing robust routines, the software removes background noise and cosmic ray events from pattern with a convenient interface that also permits comparison of multiple spectra. CrystalSleuth can automatically locate and store peak positions, and search/match by referencing peak positions against the online database. This software can be used for a comparison to the software developed in this senior design project. If a dataset for a spectrum is obtained that is calibrated, this dataset can be plotted using CrystalSleuth to see if the spectrum is calibrated properly. The software will search and match the peaks in the dataset to the peak positions provided by the RRUFF database. If the software matches the peaks in the database to the right peak relevant to the sample, then the calibration is correct.

In the lab currently is a pure silicon sample that can be used to test the Raman system. The RRUFF database is used to look up the standards for this sample in terms of where a spectral line should appear. A dataset is provided for a Silicon Raman spectrum, which is taken from a Thermo Almega XR raman system that is operated with a laser at 780 nm with a power of 600 mW. This spectrum is looked at because the laser excitation wavelength is near what is used in this senior design project. The figure below shows the silicon Raman spectrum.

Calibration of the x-axis or the wavenumbers in a Raman spectrum is done by instument manufacturers by using the following samples and spectra lines. Barium

Sulphate has a strong band at 988  $\text{cm}^{-1}$ , and diamond a band at 1364  $\text{cm}^{-1}$ . A neon lamp on the beam axis can also provide a wavelength calibration standard. Halogenated dienes and cyclohexane have been suggested as possible wavelength wavenumber standards as well. An ASTM standard (ASTM E 1840) has now been established for calibrating the Raman shift axis. Eight common chemicals - 1,4-bis(2-methylstyryl) benzene, naphthalene, sulphur, 50/50(v/v)toluene/acetonitrile, 4-acetamidophenol, benzonitrile, cyclohexane, and polystyrene had the Raman spectra recorded by six different laboratories using both dispersive and FT spectrometers. Apart from a few of the values at high and low frequencies, standard deviations of  $<1 \text{ cm}^{-1}$  were reported.

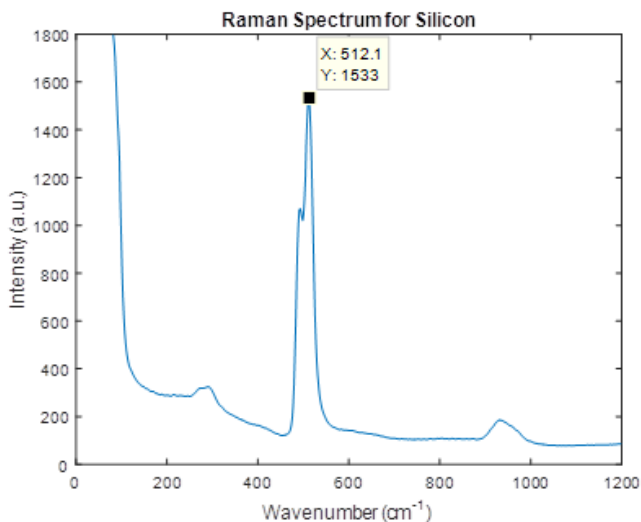

**Figure 3: Silicon spectrum from RRUFF database.**

## 4.5 Design Constraints

### 4.5.1 Size Constraints

The Raman spectroscopy device is intended to be set up and operated in a lab space that has already been selected, which is shown in Figure 4. Thus, the size of the spectrometer must conform to the space available in the lab. The lab space is a counter that is six feet long and two feet deep. This space is shared by the spectrometer, the microscope, and a computer.



**Figure 4: Lab space available for Raman microscope**

The microscope has a base that is approximately 8 inches wide and 11 inches deep. Additionally, the port to allow the laser and the backlight to be coupled into the microscope is 14.1 inches from the base. The spectrometer must be designed so that the input and output is aligned with the microscope port.

The sponsor does not want anything placed behind the microscope. Thus, the spectrometer and the microscope must be positioned side by side. The computer will be placed next to the microscope on the opposite side from the spectrometer. These three components together can be no longer than the 6 feet of available space.

There is a cupboard above the lab space that is about 2 feet from the lab surface. Therefore, the spectrometer cannot be more than 2 feet in height. This includes the area in front of the cupboard, since the cupboard has doors that must be able to swing open.

#### 4.5.2 Electrical Constraints

All of the electronics inside the spectrometer box should be run off of a single 5 volt power source. This would allow the entire spectrometer to be powered by a single wall outlet. However, this does not include the backlight for the microscope, which comes with its own power supply.

#### 4.5.3 Optical Constraints

The spectrometer uses a laser with a wavelength of 785 nm, which is provided by the sponsor. All of the optics inside the spectrometer must be designed to operate with this wavelength. This may mean that certain types of optics, such as lenses and mirrors, require coatings to ensure high levels of transmission or reflection at 785 nm. Additionally, the detector that is used by the spectrometer must have high sensitivity near 785 nm wavelengths.

In addition to the laser, the sponsor has provided several Volume Bragg Gratings (VBGs) and notch filters to be used in the spectrometer. These provide useful functions

as described in their respective sections, and should be incorporated into the spectrometer design.

#### 4.5.4 Analysis Constraints

The spectrometer must measure the Raman spectrum of  $\pm 200 \text{ cm}^{-1}$  from the laser wavelength. In terms of wavelength, the spectral range is from 772.87 nm to 797.52 nm. The spectrometer must be designed so that it can at least measure this spectral range. It is not bad if the spectrometer can measure wavelengths outside of this range, but the focus should be on the wavelengths within this range.

The spectral resolution of the spectrometer should be better than  $5 \text{ cm}^{-1}$ . This is an upper limit for the resolution. Ideally, the resolution should be as good as possible. If possible, the resolution should be closer to 1 or  $2 \text{ cm}^{-1}$ .

#### 4.5.5 Safety Constraints

The Raman microscope contains a laser, which has the potential to be hazardous to the eyes of a user or bystander. Accordingly, this system must be designed so that it is a Class I laser device. A Class I device has safeguards put in place so that users cannot be exposed to hazardous laser radiation.

The laser itself will be contained inside the box with the spectrometer. The box will not be transparent, preventing any laser radiation from escaping. Additionally, the box will be sealed with screws, which will allow access to the optics inside while preventing any user from accidentally opening the box.

The microscope is the only part of the device that potentially could let a user be exposed to the laser. The laser is focused down onto the sample, which scatters the laser radiation. This could be potentially harmful to anyone observing the sample. In order to prevent this, the microscope should also be encased in its own box.

Unlike the spectrometer, the microscope will need to be easily accessible for any user. Thus, the microscope box will have an opening with a cover on it. Systems should be put into place so that the laser can only be activated when the cover has been closed, and no user is able to observe the sample.

The microscope head has both a camera port and eyepieces. The eyepieces should be encased inside the box as well. However, there should be additional safeguards put into place so that it is impossible for anyone to accidentally be exposed to the laser through the eyepieces.

#### 4.5.6 Auxiliary Constraints

The spectrometer and all of the components inside is the only systems that will be designed instead of acquired. There are two main systems that the spectrometer must use in order to fulfill its functionality. These are the microscope and a computer.

The sponsor for this project is providing an Olympus BH-2 microscope which will be used with the Raman spectrometer. This microscope contains a port that allows the laser and a backlight to be coupled directly into the microscope. The spectrometer

must be able to use this port to input the laser and receive an output through this port. This port is located 14.1 inches from the base of the microscope.

The laser must be aligned very precisely into the microscope. Any small movements of either the spectrometer or the microscope can cause the two systems to be misaligned. As a result, the microscope should be physically attached to the spectrometer box.

The other main component that must be included is a computer. This computer must have USB ports to allow it to connect to the camera and the spectrometer. Additionally, it must be capable of running the software necessary to analyze and display the data from the spectrometer.

#### 4.5.7 Software Constraints

The display for the spectrometer will be controlled by a computer connected to the spectrometer. This computer will run software that can analyze and display the results, as well as control the functions of the spectrometer.

The primary purpose of the spectrometer is to measure and display the spectrum. As such, the computer must be able to show the spectrum on the monitor. Additionally, the computer should be able to read and display a feed from the camera attached to the microscope. This camera feed is the only way to view the sample, since the eyepieces will be blocked as described in Section 4.5.5.

In addition to displaying information, the computer must be able to control the functionality of the spectrometer. This includes controlling the laser power, both toggling the laser on/off and setting what power the laser is at.

The temperature inside the spectrometer should also be displayed on the monitor. Another display should alert the user if the microscope doors are open.

#### 4.5.8 Cost Constraints

The sponsor is paying for the spectrometer in order to have it in his lab, and is willing to pay significant amounts of money for it. He has already provided most of the more expensive components, such as the laser, VBGs, notch filters, and the microscope. He is also willing to pay for any additional equipment outside of the spectrometer that we might need.

The sponsor has not given us a project budget, with the understanding that we will not be wasting money. Many of the components, particularly optical components, can be very expensive, with no cheaper option available. As a result, we must use our wisdom and judgment to ensure that we purchase items that are cheap while still retaining the functionality required.



## 5 Project Hardware and Software Details

### 5.1 Initial Design and Architecture

#### 5.1.1 Design Overview

The design of the Raman spectroscopy microscope requires integrating many different components. The functionality and sequence of these components is shown in Figure 5.

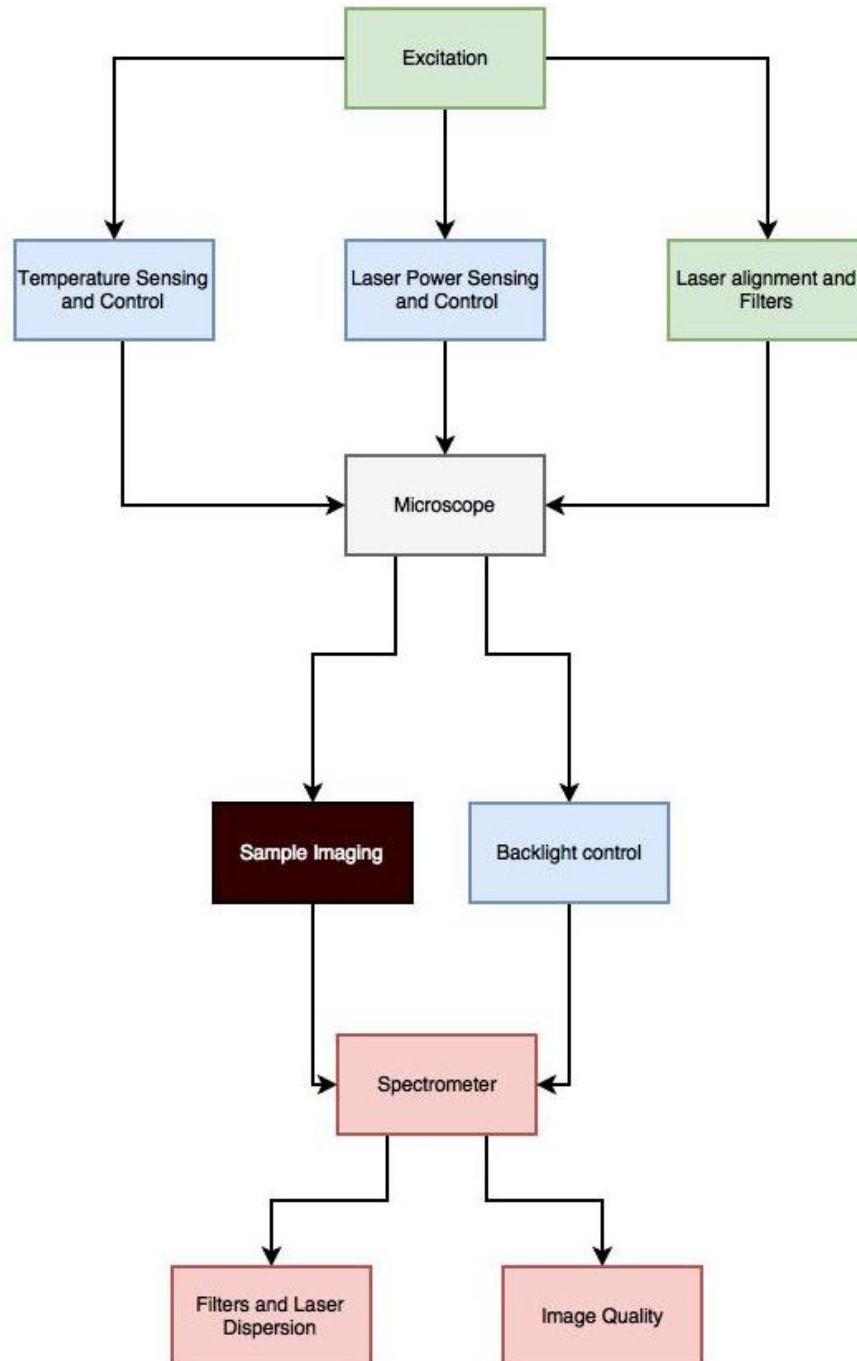

Figure 5: Device Functionality

The design can be split into two major sections: the optics and the electronics. The electronics is much easier to design, and can easily be integrated around the optics. However, the optics requires careful alignment, and as a result the overall design architecture is primarily dictated by the optics of the device.

An integrated schematic of all of the components of the system is shown in Figure 6. Following sections provide details for each of the subsystems in Figure 6. Brief descriptions are given, but they are not intended to be exhaustive. A more complete description of the operation and specifications is provided in each part's section later.

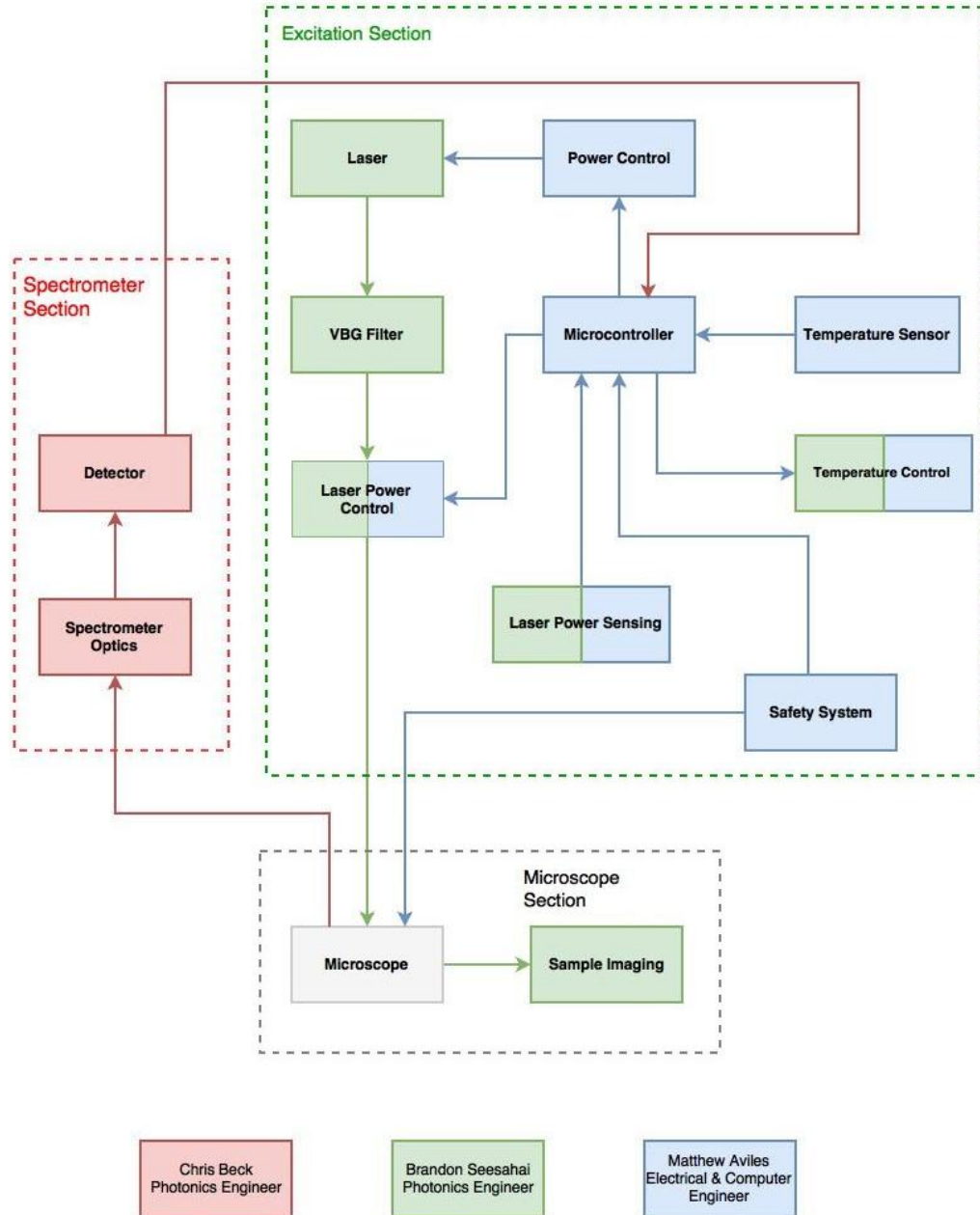

Figure 6: Diagram of all major subsystems in the Raman microscope

### 5.1.2 Optical Design

The optical design has two main components: the excitation and the spectrometer. The purpose of the excitation is to couple the laser into the microscope in order to induce the Raman signal. The spectrometer then collects the Raman signal and analyzes it in order to obtain the Raman spectrum. The overall optical design is shown in Figure 7. This design will be elaborated on in the following sections.

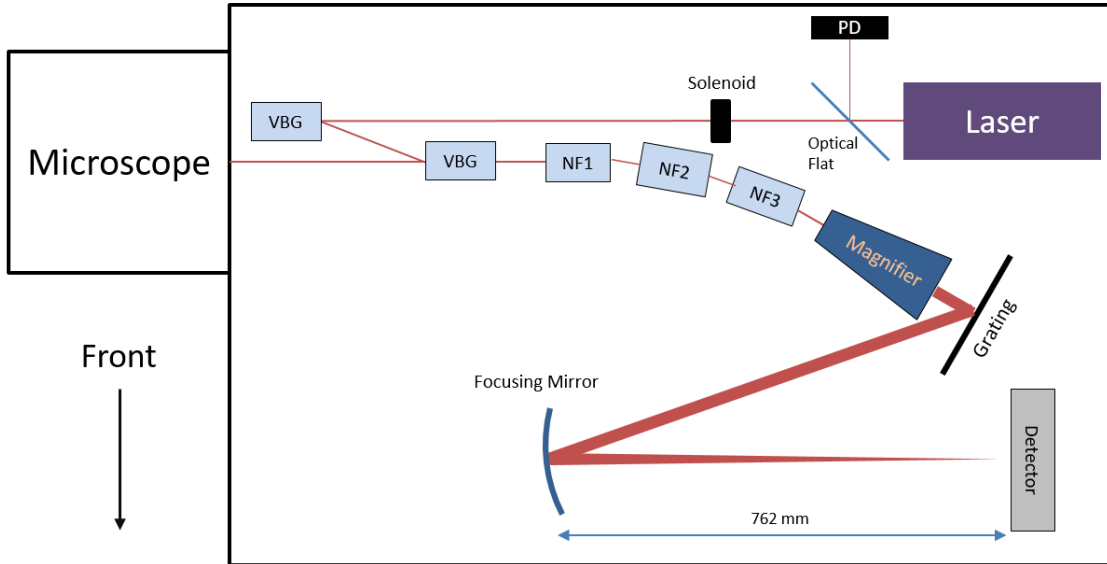

Figure 7: Top-down view of the Optical Design

This design is not drawn fully to scale. Many of the distances and angles incorporated in the design may change, sometimes drastically, during the alignment of the optics. There are only a few dimensions that are fixed, which will be discussed in their own sections. However, the basic structure of the optical design should remain essentially the same as what is shown in Figure 7.

#### 5.1.2.1 Excitation Section Design

The excitation phase begins with the laser. The laser outputs light at 785 nm. However, the laser cannot be passed directly into the microscope. It must be spectrally filtered using the two Volume Bragg Gratings (labelled VBG in Figure 7) in order to ensure that the laser light incident on the sample is exactly 785 nm. This helps to increase the overall resolution of the spectrometer.

In order to measure the power of the laser, an optical flat is placed in the path of the laser to redirect a fraction of the laser power onto a photodiode (labeled PD in Figure 7). This photodiode can continuously monitor the power of the laser, even when the sample is being analyzed with the spectrometer.

The purpose of the solenoid is to physically block the laser light if any of the interlocks are compromised. This ensures that the Raman spectroscopy microscope remains a Class I device. The solenoid is controlled by the microcontroller.

Once the laser beam has been spectrally filtered by the VBGs, it is coupled into the microscope. The microscope uses a dichroic filter to direct the beam into the

objective lens and onto the sample. The dichroic filter has high reflectivity for the spectral range of the Raman signal, but high transmission for the majority of the visible spectrum range. This allows the camera attached to the microscope to view the sample while still directing the Raman signal into the spectrometer.

The microscope focuses the laser onto the sample, inducing Raman scattering. This Raman signal is collected by the microscope objective and is directed back into the box, where it is passed to the spectrometer.

The figure below shows the excitation system and the microscope as two separate systems. The goal of this senior design project is to combine these two systems to create a Raman excitation on a sample that is placed on the microscope's sample stage.

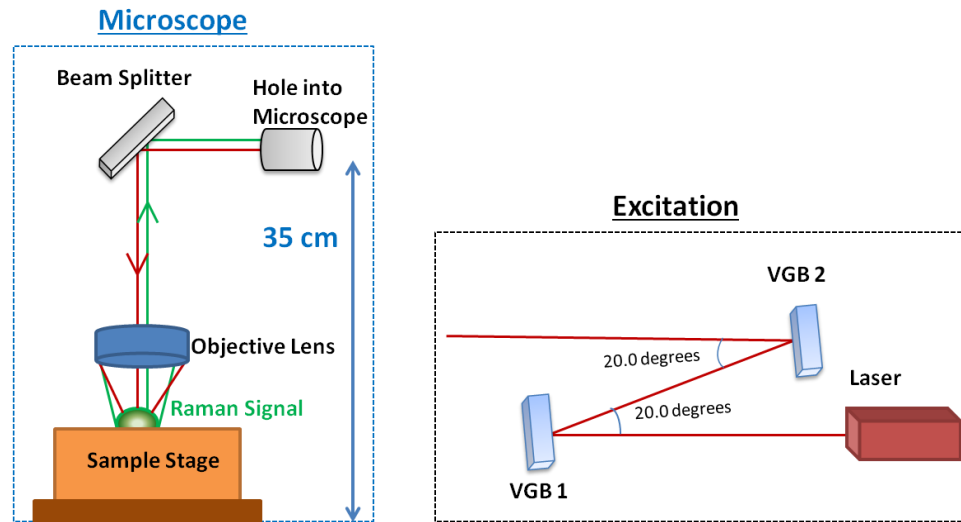

Figure 8: The Microscope and the Excitation as two separate systems (not drawn to scale).

The excitation system is important for creating the Raman signal that will have to be captured by a spectrometer to create a spectrum. If the excitation system does not create a Raman signal with sufficient intensity, then it will make the Raman signal harder to capture and display into a spectrum. A high intensity excitation is created by making sure that the full beam of the laser signal is being guided into the hole of the microscope. If part of the laser beam is cut off from the edge of the microscope hole, or from the optics (VGBs), then the full intensity of the beam is not being used to create the excitation. Furthermore, if the full laser beam is injected into the microscope, then it is important that the beam splitter is reflecting the laser beam onto the objective lens so that a strong focusing can occur for excitation. The angle that the beam splitter is tilted can be adjusted to ensure that the laser is being guided toward the objective lens.

The laser beam will have a certain linewidth to its spectral profile that will limit the resolution of the Raman signal. By aligning the laser beam to Volume Bragg Gratings (VGBs), the linewidth of the laser beam's spectral profile is reduced. Using two VGBs will allow for a precise narrowing of the laser linewidth. The VGBs also have an input and output angle that the laser beam must travel in order for the full narrowing capabilities of the VGBs to be used. At other angles that the VGBs linewidth narrowing

capabilities does not work, the intensity of light or the optical density reflected off its surface will have a low intensity. Time must be taken so that the laser is aligned toward both of the VGBs. This is done by aligning the full laser beam unto the first VGB, and then slowly varying the angle of the VGB until the intensity of light reflected is the most intense. This same process is repeated for the second VGB. Once the full intensity of the laser beam is reflected off VGB 2, a method has to be implemented to guide the laser beam toward the hole of the microscope.

The height of the hole from the bottom of the microscope is approximately 35 cm and the optics and lasers are mounted on an optics platform about 33 cm below the hole. Since there is a height difference between the optics and the microscope hole, different designs must be used to make sure that the laser beam is being directed upward. If there are not any designs to guide the laser beam to the hole, then the excitation setup will have to be at a far distance just to reflect the laser beam into the hole, and this is not feasible and goes against design constrains. The idea of the Raman attachment is to be close to the microscope and to not make the entire system bulky. Furthermore, having a laser beam travel a far distance to the excitation point will cause the laser beam to diverge and lose intensity.

One design as shown below is to use a periscope. A periscope is an instrument for observation over, around or through an object, obstacle or condition that prevents direct line-of-sight observation from an observer's current position. For example, during World War II (1939-1945), artillery observers and officers used specifically-manufactured periscope binoculars to observe enemies while holding position in a trench. The periscope allowed for something to be viewed that was at a higher point. The periscope can be incorporated in excitation design to elevate the laser beam toward the hole of the microscope and consists of two reflecting mirrors. The two reflecting mirrors must have specifications that will not only reflect the wavelength of the laser, but also the Raman shifted wavelengths because both signals are traveling through the same path.

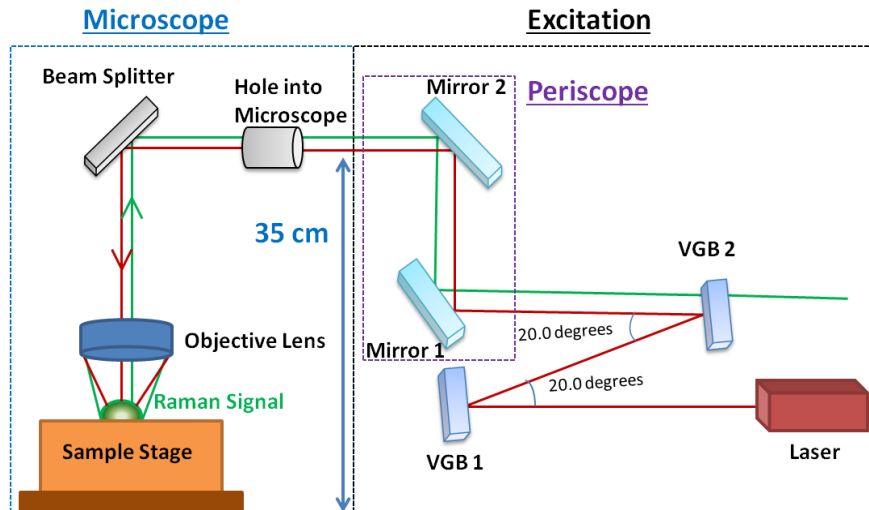

Figure 9: Excitation optical schematic with periscope.

A second design is to elevate the excitation system at approximately the same height as the hole of the microscope. If the excitation system is on a platform, legs will have to be mounted below the platform at the appropriate height. The figure below shows the excitation system with legs that provides elevation. For the alignment in this system, the laser beam will only propagate through the two VGBs and be centered onto the hole of the microscope. If the laser beam is not centered onto the hole, then the full beam will not be incident on the beam splitter. Careful design on the height of the legs supporting the platform ensures that the optical alignment can allow for the laser beam to be centered onto the hole. If the legs are too high or too low, then the laser beam cannot propagate in a straight path through the hole and unto the beam splitter and will experience intensity loss.

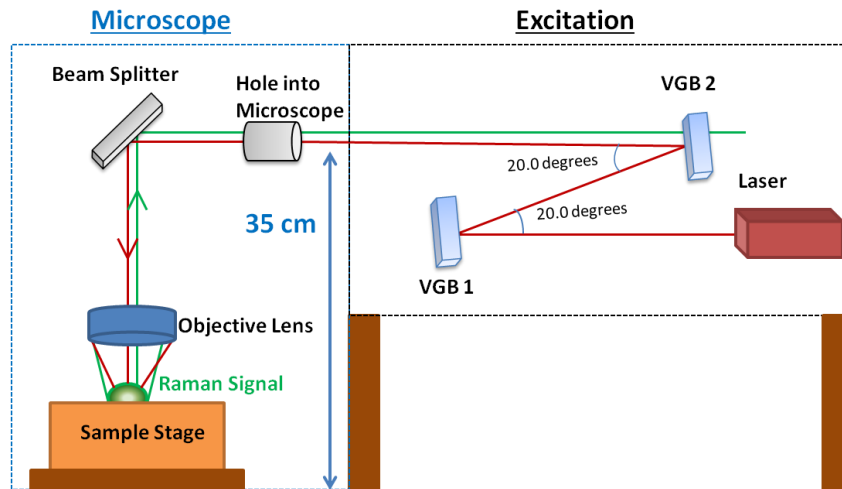

Figure 10: Excitation optical schematic with elevation.

The last design that can be used to connect the excitation and microscope system is to use a fiber to couple the laser light unto the microscope hole. The design is shown in the figure below. The laser light reflected off VGB 2 will have to be aligned toward the center of the fiber so that most of the intensity of the beam can be captured and guided toward the microscope.

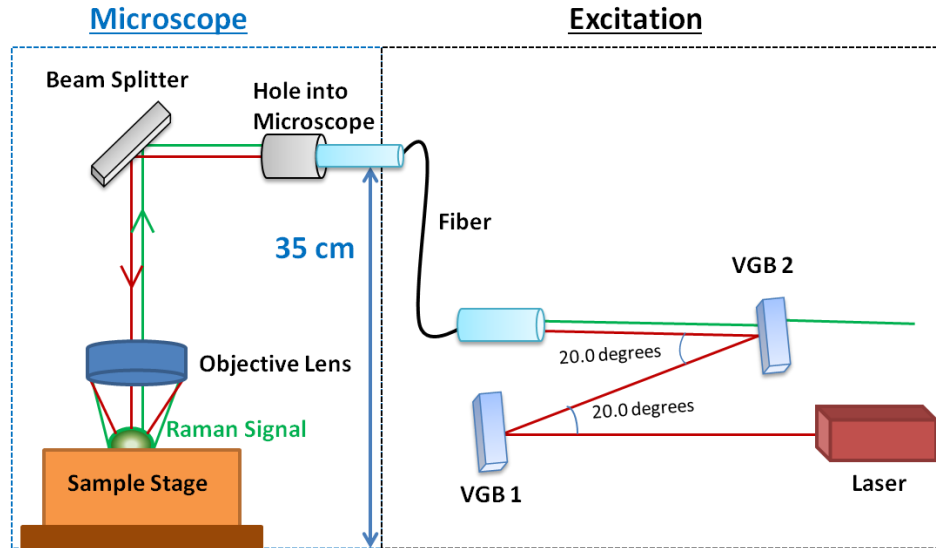

Figure 11: Excitation optical schematic with fiber coupler.

This fiber design is beneficial because buying a short fiber cable to connect both systems is cheaper than buying a two broadband mirrors for a periscope. Furthermore, the fiber can be surrounded by an adaptor, which can be easily inserted into the hole of the microscope. Although the fiber design does require an alignment of the laser light unto the fiber, there are less alignment requirements than the periscope design. The benefit of the elevated design is that it is cheaper than the periscope and the fiber coupling design because there is no added optical components. A disadvantage for the elevated design is that the VGBs cannot be tweaked for a wide range of angles to get the laser beam into the microscope hole, which makes alignment a lot more difficult. The best procedure is to set the VGBs at the best angle that allows for the laser linewidth to be narrowed down and then find another means of guiding the laser light into the microscope. The disadvantage of the fiber coupling system is that there are losses involved in the laser intensity. Fibers have a numerical aperture that quantifies the amount of light that can be coupled into a fiber. If the laser beam experiences losses in its intensity when being coupled into the fiber, then the excitation signal will be weak. Then the weak excitation signal will experience loss when being coupled back into the fiber, which will make it harder for the spectrometer to capture and read the Raman signal and create a spectrum. Fibers are also known to create dispersion. Dispersion is a function of wavelength and can cause a spectral line to become more broad as it propagates in the fiber. Although dispersion is known to occur in multi-mode fibers with a long length, there is a chance that dispersion can occur for a short fiber that is integrated in this system. To minimize the laser and Raman light losses, and keep optical alignment easier, the periscope design seems to be the best choice. The mirrors can be bought with broadband qualities that have close to 99 % reflectivity, which will allow for the laser and Raman light to be reflected and guided without a lot of losses. The mirrors also allow for a wide range of angles that can cause the 99 % reflection, which makes the alignment of the laser light unto microscope hole easier.

#### 5.1.2.2 Spectrometer Design

After the Raman signal leaves the microscope, it once again is incident on the second VBG. This VBG acts as a notch dichroic filter, reflecting only the 785 nm laser line, while transmitting all other wavelengths. The Raman signal passes through the VBG and enters the spectrometer.

Even with the VBG reflecting most of the laser line, a significant portion still enters the spectrometer. This has the potential to wash out the spectrometer, making a reading of the Raman signal impossible. Three notch filters (labeled NF1, NF2, and NF3 in Figure 7) are used to further eliminate the laser line, reducing it to intensities comparable to the Raman signal or killing it entirely. The notch filters slightly bend the path of the beam, as illustrated in Figure 7.

Once the laser line has been killed, only the Raman signal remains. The signal is passed into the magnifier, which expands the beam before it is dispersed by the grating. This is to increase the resolution of the spectrometer.

The grating disperses the Raman signal, separating the various wavelengths that compose the Raman spectrum. This dispersed signal is focused by the mirror, converting the angular dispersion into a linear dispersion.

The detector is placed in the focal plane of the mirror. This ensures that each pixel on the detector is measuring only a single wavelength of the spectrum. Additionally, the detector is positioned so that the laser line (785 nm) is incident on the center of the detector. The detector measures the intensity of the spectrum at each pixel, which can be used to obtain the spectrum of the Raman signal.

#### 5.1.3 Electronic Design

The electronics design is composed of many individual systems. An overall design architecture is provided in Figure 12. A brief description of each component will appear in subsequent sections. Some of the optical components, such as the laser and the detector, are discussed in the previous section, and are not covered here.



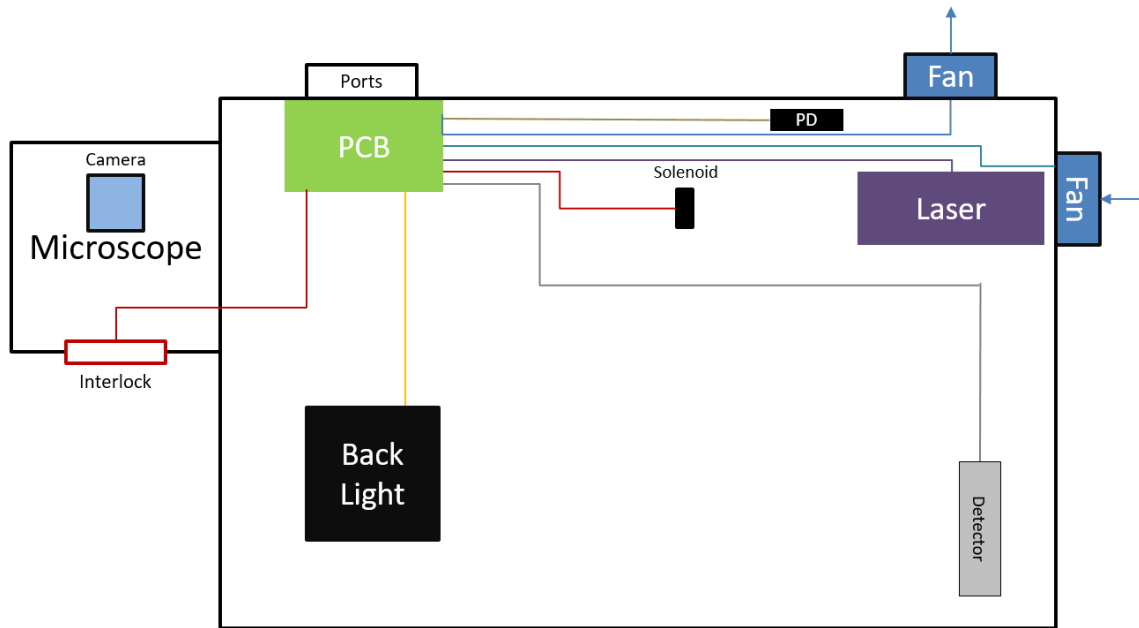

Figure 12: Top-down view of the Electronics Design

#### 5.1.3.1 PCB/Arduino

The PCB is the brains of the Raman spectroscopy system. All of the electronic components are connected and controlled by the PCB. It is mounted to the floor of the spectrometer box, with an insulating layer separating the PCB from the floor. Additionally, it is positioned next to the side of the box, so that the external ports can be incorporated directly onto the PCB.

The external ports are mounted directly into the side of the box. There are ports that allow connections to the power supply and the computer.

The wires that connect all of the interior electrical components will be attached to the floor of the spectrometer box. Exterior components are connected through ports mounted to the side of the box.

#### 5.1.3.2 Fans

There are two fans used to regulate the temperature inside the spectrometer box. They are mounted to the sides of box near the laser, which is the component that will create the most heat. One of the fans pulls cool air into the box, while the other fan ejects the warm air from the box. Each fan is controlled individually by the PCB.

#### 5.1.3.3 Interlock/Solenoid

The interlock is a magnetic switch attached to the doors on the microscope box. As long as the doors remain closed, the circuit is an active state. However, as soon as the doors are opened, the switch is tripped, which causes the solenoid to block the laser.

When the solenoid is in a deactivated state, the laser is blocked. This is to ensure that the laser is unable to enter the microscope if the doors are opened, even if the interlock circuit is somehow compromised. The solenoid is only in a state that lets the laser pass when it is powered by the PCB.

#### 5.1.3.4 Back Light

The back light is mounted to the floor of the spectrometer box. The light is coupled into the microscope through an optical cable. The back light must be controlled by the PCB so that it does not interfere with the Raman signal during measurement.

When the sample is being aligned on the microscope, the backlight must be on so that the sample is visible on the camera. However, the back light must be turned off when the Raman signal is being collected.

#### 5.1.3.5 Camera

The camera is mounted directly onto the microscope, and is connected to the computer via USB. It allows real-time viewing of the sample during alignment. This is necessary because the sample cannot be viewed through the eyepieces while the laser is on.

### 5.1.4 Microscope

The microscope must maintain careful alignment with the rest of the optical components. As a result, the microscope must be on the same platform that the spectrometer is. Additionally, the microscope is physically attached to the platform in order to prevent any movement from disrupting the optical alignment.

There are two ports that allow light to be coupled into the microscope. One of the ports is used to couple the back light, which is used to illuminate the sample as described in Section 5.1.3.4. The other port couples the laser onto the sample in order to induce the Raman scattering. Each port uses a beam splitter to accomplish the coupling. The laser beam splitter is a dichroic filter, which is designed to reflect the laser line and all of the Raman spectrum while transmitting everything else. The back light beam splitter is not intended to filter any particular wavelength.

The camera is mounted to the top of the microscope, as discussed in Section 5.1.3.5. There is also a bi-ocular eyepiece on the microscope, but the eyepieces are blocked in order to prevent accidental viewing of the laser.

### 5.1.5 Box Design

The entire Raman spectroscopy system must be encased in a box, for several reasons. First, in order to be a Class I device, no dangerous laser light must be visible to any observer when the device is under normal operating conditions. Thus, any portion of the device that involves the laser must be contained inside a box. Additionally, the spectrometer should be completely isolated from any light other than the Raman spectrum being analyzed in order to accurately measure the spectrum.

The microscope and the spectrometer should also be isolated from one another. It is possible for scattered laser light from the microscope to contaminate the spectrometer unless there is a divider in place between the microscope and the spectrometer.

Both boxes must share a common floor so that the microscope and the spectrometer remain fixed with respect to one another. The simplest way to accomplish this is to have the microscope box and the spectrometer box share the same floor. Not only should this floor be rigid, but it should also allow all of the optical and electronic components to be mounted directly onto the floor.

An optical breadboard is an ideal option to use as the floor of the boxes. Optical breadboards are essentially a slab of metal that has threaded holes drilled into it in a grid pattern. This provides a solid, rigid platform that allows the box to be moved without losing alignment. Additionally, the holes drilled into the platform allows easy mounting for both optical and electrical equipment.

The walls of the boxes must be able to block out all light from entering or leaving the system. Accordingly, they should be made out of a material that is not transparent. The material has yet to be determined.

The spectrometer box should have a top that can be removed in order to access the optics inside. It should be attached to the box with screws to allow easy removal.

The microscope box has an opening in the front in order to allow loading and unloading of samples. The opening should be wide enough to allow easy access to the sample stage, as well as the focusing and translation knobs on the microscope. Sliding doors will be attached to the opening so that laser light from the microscope can be completely contained by the box. A contact switch is connected to the doors so that the laser is instantly blocked when the doors are opened.

## 5.2 Excitation System

### 5.2.1 Laser

#### 5.2.1.1 *Laser Theory and Relevant Concepts*

The word laser is an acronym that stands for light amplification by the simulated emission of radiation. The key concepts on how a laser works are amplification and stimulated emission. A laser system converts pump energy, which may be electrical or optical in nature, into intense, highly directional, nearly monochromatic, electromagnetic wave energy. There are three basic processes that affect the passage of radiation through matter and is shown in the figure below. These processes are known as simulated absorption, simulated emission, and spontaneous emission. Simulated absorption, or simply absorption, is the process by which electromagnetic waves transfer energy to matter. An atom can be raised or excited from a lower state of energy  $E_1$  to a higher energy state  $E_2$  by absorbing a photon with an energy approximately equal to  $h\nu_0 \approx E_2 - E_1$ . Spontaneous emission can take place if an atom is in an excited state even when there are no photons incident on the atom. In this process, an atom in an excited state with energy  $E_2$  spontaneously gives up its energy and falls to the state with energy  $E_1$  and releases a photon of energy  $h\nu_0 \approx E_2 - E_1$ . The atom relaxes to a lower state because there is a lifetime that the atom will remain in the excited state. The photon is emitted in a random direction. The spontaneous emission from a sample of atoms will not all emit light precisely at a frequency,  $\nu_0$ , but will emit light with a range of frequencies characterized by a linewidth  $\Delta\nu$ . In other words, the spectrum of atoms that spontaneously emit will have the same frequency dependence as a lineshape function  $g(\nu)$ . Simulated emission occurs when an atom in an excited state  $E_2$  encounters a photon of energy  $h\nu_0 \approx E_2 - E_1$ . The incident photon can stimulate the atom in the energy state  $E_2$  to drop to the lower energy state  $E_1$ , which causes the atom to release a photon with the same energy, direction, phase, and polarization as that of the incident photon. As a result, the energy of

the electromagnetic wave passing by the atom is increased by one quantum  $h\nu_0$  of energy. It is simulated emission that makes possible the amplification of light within a laser system. The fact that simulated emission produces a twin photon yields the unique degree of monochromaticity, directionality, and coherence associated with laser light.

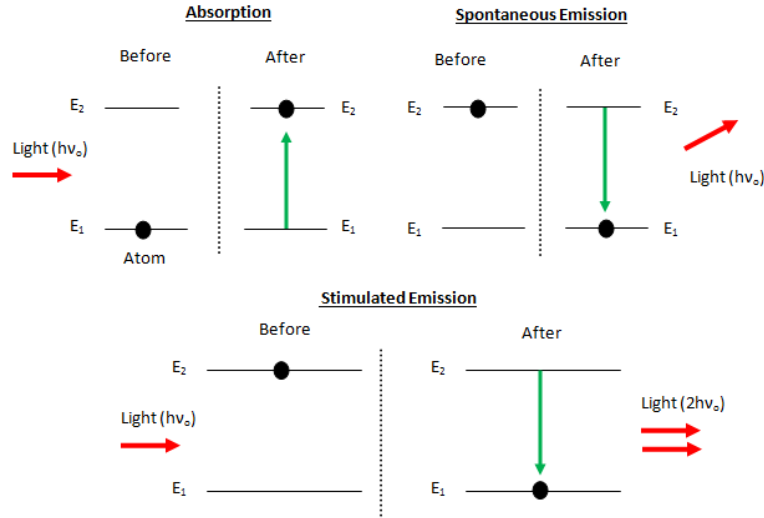

**Figure 13: Three basic processes that affect the passage of radiation through matter.**

Having a monochromatic light source is important for Raman spectroscopy because it measures the shift in wavelength or frequency that is reemitted by a sample after absorbing a certain wavelength or frequency. If a broadband light source is used to illuminate a sample, the Raman shift signal will be induced at different wavelengths, which creates a signal with interference. To obtain a Raman shift signal that can be accurately induced to portray a certain signature of a sample, a laser or a monochromatic light source must be utilized.

The Boltzmann distribution gives the probability that an assembly of atoms will populate a certain energy level and is given by the equation below.

$$\frac{N_2}{N_1} = \exp -(E_2 - E_1) / k_B T \quad (4)$$

Where  $N_2$  is the population of atoms. The Boltzmann distribution explains that for a given assembly of atoms in thermal equilibrium, a larger population of atoms will be in a lower energy state than a higher energy state. Therefore, absorption will occur more often than stimulated in an assembly of atoms in thermal equilibrium. In order of atoms to amplify by the means of stimulated emission, a large population of atoms must be in the excited state and this is made possible by supplying pump energy. When considering an assembly of atoms where a larger population density is in a high energy state than a low energy state, a population inversion exists.

A laser requires three essential elements, an external energy source or pump, a gain medium, and an optical cavity, or resonator. The pump is an external energy source that produces a population inversion in an assembly of atoms. Amplification will only

occurs in a medium that exhibits a population inversion. Otherwise, light will be attenuated through the medium or the assembly of atoms. Pumps can be optical, electrical, chemical, or thermal in nature. The assembly of atoms represents the gain medium. The inherent energy levels in the gain medium determine the wavelength of light emitted from a laser. Once a pump is used to create population inversion in a laser medium, a resonator or an optical feedback device is needed to direct photons back and forth through the laser (amplifying) medium. The resonator contains a pair of mirrors with one have a reflectivity of 100 % and the other having a reflectivity less than 100 %. The less reflective mirror is used so that the amplifying light can be outputted as the laser beam.

A laser cavity consisting of two mirrors separated by a distance  $L$  will support standing wave modes of wavelengths  $\lambda_m$  or frequencies  $\nu_m$  according to the equation below.

$$m \frac{\lambda}{2} = L \tag{5}$$

where  $m$  is an integer called the longitudinal mode number. In addition to the optical cavity to acting as a feedback device, it acts as a frequency filter. Only electromagnetic fields that have frequencies near the resonant frequency of the gain medium and near the standing wave frequency of the cavity will be present at the laser output. An example is shown in the figure below. Since the laser used in this senior design project has a wavelength of 785 nm, then the gain medium in this laser will have a lineshape function with a line width. Consider that the lineshape function has a lorentzian profile. The orange stem lines in the figure shows the allowed wavelength modes in the cavity. The distance between the wavelength modes are called the free spectral range. If there are no losses from the cavity, that is, the mirrors are perfectly reflecting, then the stem lines would be sharp lines as shown. If the mirrors are not perfectly reflecting so that some radiation escapes from the cavity, then the mode peaks are not as sharp and have a finite width. The wavelength mode that will lase is the one closest to the peak of the optical gain curve.

Broadening in the optical gain curve is caused from broadening mechanisms such as homogenous broadening or inhomogenous broadening. Homogenous broadening occurs when all atoms emit the same spectrum with the same center frequency, which results in a single mode lasing output. Types of homogenous broadening is caused from collision broadening and pressure broadening from the ions or phonons in the gain material. Inhomogeneous broadening occurs when different atoms emit at slightly differing central frequencies, due to random processes shifting the peak emission frequency. An example of inhomogenous broadening is doppler broadening, which is caused from the Doppler effect. Atoms moving away and towards an observer will cause a detection of a range of frequencies. Inhomogenous broadening results in a multimode or single mode lasing output.

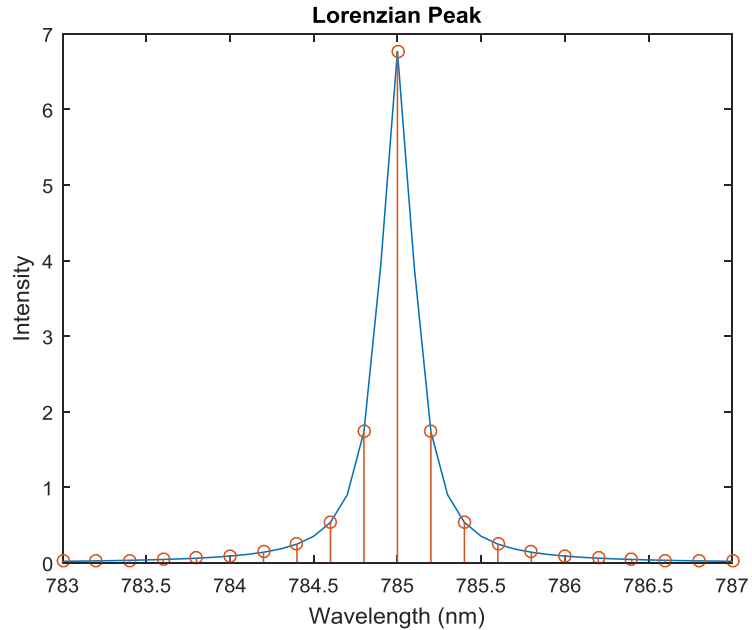

**Figure 14: Optical gain curve and wavelength cavity modes.**

For a single mode laser output, the amplitude of the field as a function of the radial coordinate changes as the beam propagates along  $z$ . Overall, the intensity profile a single mode laser beam has a Gaussian profile. The figure below shows the spreading or divergence of a 2-dimensional Gaussian profile beam as it propagates in the  $z$ -axis. The equation for the amplitude of the field as a function of the radial coordinate is shown below as well as the equation of the spot size of the beam as it propagates. The equation for the intensity of the laser beam shows that the intensity is the greatest at the center of the beam, which is important to know when performing laser power measurements. If the center of the laser beam is not on the photodiode, then the generated current is not an accurate representation of the full power of the beam. To accurately know the power of the laser beam, the center of the laser beam must be aligned correctly for measurements.

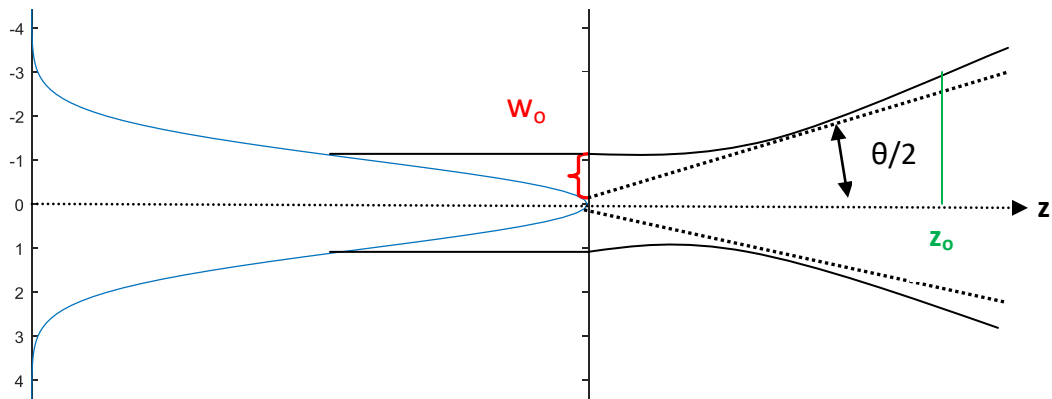

**Figure 15: The spreading of a 2D dimensional Gaussian beam profile as it propagates in the  $z$ -axis.**

$$\frac{E(x,y,x)}{E_o} = \frac{w_o}{w(z)} \exp \left[ - \left( \frac{r}{w} \right)^2 \right] \quad (6)$$

$$w^2(z) = w_o^2 \left[ 1 + \left( \frac{z}{z_o} \right)^2 \right] \quad (7)$$

$$w_o^2 = \frac{\lambda_o z_o}{\pi n} \quad (8)$$

$$\frac{\theta}{2} = \frac{\lambda_o}{\pi n w_o} \quad (9)$$

Where the variable  $w_o$  is called the minimum spot size of the laser beam and is indicated in red in the figure above and  $z_o$  is the position where the minimum spot size is equal to  $w_o\sqrt{2}$ . The variable  $\theta$  is the expansion angle of the beam and this is the minimum angular spread that a beam of diameter  $2w_o$  can have. As a laser beam propagates, the beam waist expands or diverges according to equation 7, which provides a larger FWHM for the intensity profile of the laser beam. In addition, having a laser beam diverge in an optical setup causes the intensity at the center of the beam to decrease because of the larger spot radius. As a result, if certain optics (volume bragg gratings, photodiodes, and fiber) have a small area for light to become incident on, then it is important for the laser beam to not diverge and have most of its intensity concentrated within its center. This is also helpful to create a Raman excitation signal because a high intensity beam will be incident on a sample.

The type of laser wavelength used does affect a Raman spectrum. Laser wavelength ranging from ultra-violet through visible to near infrared can be used for Raman spectroscopy. Typical examples laser wavelengths include the following.

- Ultra-violet: 244 nm, 257 nm, 325 nm, 364 nm
- Visible: 457 nm, 473 nm, 488 nm, 514 nm, 532 nm, 633 nm, 660 nm
- Near Infrared: 785 nm, 830 nm, 980 nm, 1064 nm

The choice of laser wavelength affects the spatial resolution or the diameter on a sample that is excited because of the laser spot size. Since the laser is focused onto a sample using an objective lens on the microscope, the spot size of the laser will be diffraction limited. The equation for the diffraction limited laser spot diameter is shown below.

$$spatial\ resolution = 0.61 \frac{\lambda}{NA} \quad (10)$$

where  $\lambda$  is the wavelength of the laser and NA is the numerical aperture of the microscope objective being used. For example, with a 532 nm laser and a 0.90/100x objective, the theoretical spot diameter will be 0.36  $\mu\text{m}$ . With the same objective, a 785 nm laser would yield a theoretical spot diameter of 0.55  $\mu\text{m}$ . This shows that spatial resolution decreases when laser wavelength increases. While this equation is applicable for standard light microscopy, the optical processes occurring during Raman microscopy are more complex. For example, scattering of the laser/Raman photons and interaction with interfaces in the sample can reduce this resolution.

An important concept to understand about laser wavelength and Raman excitation is the following. The Raman signature and the specific peak position of any material is related to the material's unique chemical structure and is independent of the excitation wavelength, so the molecular fingerprint will be the same regardless of the excitation laser wavelength. However, different excitation wavelengths provide specific strengths and weaknesses allowing a user to optimize the measurement of different samples by their choice of Raman excitation wavelengths. For instance, the strengths and weaknesses for the three most widely used laser wavelengths for Raman spectroscopy is shown below.

**Table 5: Effect that different excitation wavelengths have on wavelengths excitation, fluorescence, and heat absorption.**

	532 nm	785 nm	1064 nm
Excitation Efficiency	high	medium	low
Fluorescence	high	medium	low
Heat Absorption	low	medium	High

The most important affect that different laser wavelengths have is excitation efficiency or the Raman scattering intensity. Raman scattering efficiency is proportional to  $\lambda^{-4}$ . For example, Raman scattering at 532 nm is a factor of 4.7 more efficient than at 785 nm and 16 times better than 1064 nm, The equation for Raman scattering efficiency is shown below.

$$P_{scattered} \propto \frac{I_0}{\lambda^4} \tag{11}$$

Where  $I_0$  is the intensity of the light incident on the sample. Another important phenomenon that occurs and interferes with the measurement of the Raman spectrum is fluorescence. Fluorescence is produced in a similar process to Raman scattering, but is based on a different mechanism. Fluorescence can add to the background of a spectrum and create error in the intensity or formation of a spectral line. To minimize interference of fluorescence with a Raman spectrum, longer wavelength excitation is used. Laser absorption is considered as well because it can cause sample heating and lead to changes in the samples such as a change in sample color or sample destruction. The longer the excitation wavelength, the more the sample absorbs light and is heated. For longer wavelengths, the laser power can be reduced to avoid heating the sample, but the



collection time increases for acquiring spectra increases and the signal-to-noise ratio (SNR) decreases.

The 532 nm laser excitation is good for carbon nanotube analysis, metal oxides or minerals, and inorganic materials. A 532 nm instrument can also benefit for covering the full spectral range from  $65\text{ cm}^{-1}$  and  $4000\text{ cm}^{-1}$ , which is good for applications where distinct signals in the higher Raman shift region is necessary. The 785 nm wavelength excitation is the most popular and common wavelength used in Raman spectroscopy because it performs efficiently for over 90 % of Raman active materials with limited interference from fluorescence. Between the 3 standard wavelengths, the balance of fluorescence reduction and spectral resolution makes the 785 nm the most versatile choice.

#### 5.2.1.2 Laser Parts Comparison and Specifications

When precision and repeatability matter, Innovative Photonics Solution (IPS) lasers are ideal for use in Raman spectroscopy, microscopy, fiber laser seeding & pumping, remote sensing, THz generation, imaging and illumination & many other applications. IPS supplies over 80 % of all OEM (original equipment manufacturer) Raman manufacturers with diode based excitation sources for microscopy and hand-held spectroscopy. IPS produces are also known for their high performance and reliability. IPS offers over 50 standard wavelengths ranging from 405 nm to 1570 nm. The lasers are offered in single mode or multi-mode and can be ordered free space or fiber coupled. OEM components and OEM modules can be offered with integral control electronics, along with fully "turn-key" UL/CE and IEC certified systems. The laser used for the Raman spectroscopy senior design project is going to come from IPS and will have a wavelength of 785 nm.

The laser that is currently in the lab is a 785 nm single mode spectrum stabilized (SS) laser, which features high output power with ultra-narrow spectral bandwidth and a circularized and collimated out beam. Designed to replace expensive, distributed feedback (DFB), distributed bragg reflector (DBR), fiber, and external cavity lasers, the Single-Mode Spectrum Stabilized Laser offers superior wavelength stability over time, temperature ( $0.007\text{ nm}/^{\circ}\text{C}$ ), and vibration, and is manufactured to meet the most demanding wavelength requirements. Overall, the laser comes standard with a circularized and collimated output beam, integral laser line filter, internal thermistor and thermoelectric cooling (TEC), linear tracking photodiode and Electrostatic Discharge (ESD) protection. Lasing wavelength can be accurately specified and repeatedly manufactured within 0.1 nm. The laser is ideal for high resolution Raman spectroscopy, confocal microscopy, metrology, and interferometry applications.

The figure below shows the 785 nm SS laser spectrum at 25 degrees Celsius. Unfortunately, the spec sheet for this laser does not show the FWHM of the laser spectrum. By examining the figure below, the FWHM of the spectrum can be approximately determined. The peak of the spectrum is at around -162 dBm. By taking the -862 dBm as the zero, the peak of the spectrum is 700 dBm away from -862 dBm. Half of 700 dBm is 350 dBm, so the FWHM would be around -350 dBm. The black line in the figure below shows an approximate location for -350 dBm. Knowing that each vertical division in the graph is 2 nm and the length of the peak (2 nm) at -350 dBm, the FWHM can be approximated. Since a little more than 2 of the red line can be fitted in a

single division, it is approximated that around 2.3 of the red line can be fitted. Dividing 2/2.3 gives a value of 0.87 nm. Therefore, the FWHM of the laser line is around 0.87 nm. Notice that getting closer to the baseline of the spectrum, the peak is broader, which is around 2.5.

y

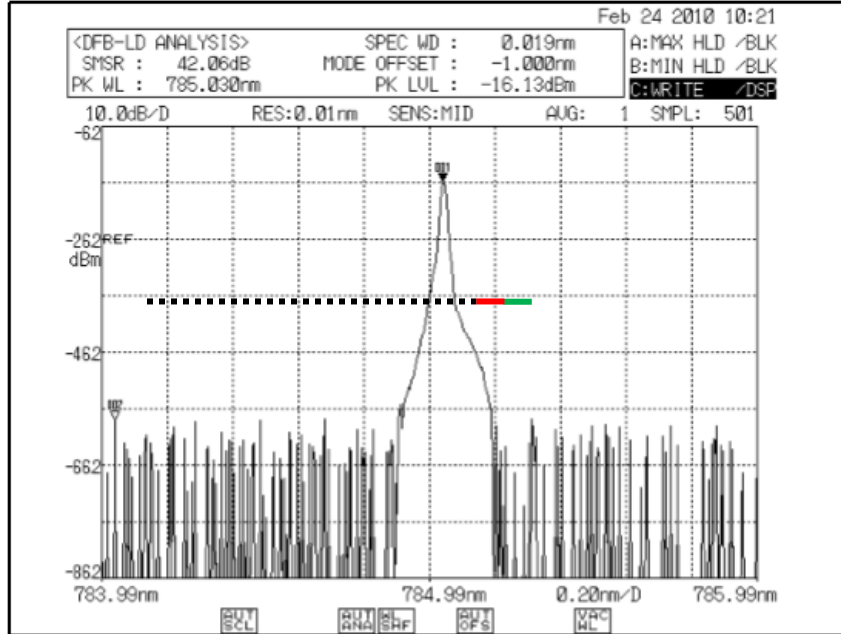

Figure 16: Laser Spectrum for IPS laser I0785SA0100B at 785 nm (permission granted).

IPS most recent laser (I0785SD0050PA-IS) at 785 nm in its product list has a FWHM of around 1.3 nm and can be as broad as around 3.0 nm near the baseline of the spectrum. This laser does have a FWHM that is 0.43 nm greater and a width near the baseline that is 0.5 nm greater than the current laser in the lab. The I0785SD0050PA-IS laser is also more wavelength stable. The improvement in the wavelength stability is shown in the figure below. The figure shows that the measured wavelength of the laser is still around 784 nm even when the laser is be operated for 12 hours, which is more than a normal work day. Unfortunately, for the IPS laser I0785SA0100B, a wavelength stability plot is not provide, which shows that this laser may be less wavelength stable than the IPS laser I0785SD0050PA-IS. Having a wavelength stable laser is important for Raman spectroscopy applications. Since Raman spectroscopy gives a spectrum of peaks that are shifted from the laser wavelength, a laser that is not wavelength stable will provide Raman spectra that is not consistent after obtaining spectra in periodic uses. Not only is consistency in a Raman spectrum lost, but also the laser may not excite certain Raman peaks if the laser wavelength fluctuates.

The IPS laser (I0785SD0050PA-IS) and I0785SA0100B have a lot of similarities besides the FWHM of the spectrum and the wavelength stability. Both lasers create a circularized and collimated output beam that is single mode, have an internal temperature control system that includes an internal thermistor and TEC, and a maximum laser output power that is around 100 mW. Another difference between both lasers is the molex connector used to control the laser characteristics. The I0785SA0100B laser comes with a 10-pin while the I0785SD0050PA-IS laser comes with a 6 pin molex connector. The 4

pins not included in the I0785SD0050PA-IS laser are two pins for temperature sensing, one pin for photodiode sensing, and a voltage set enable pin.

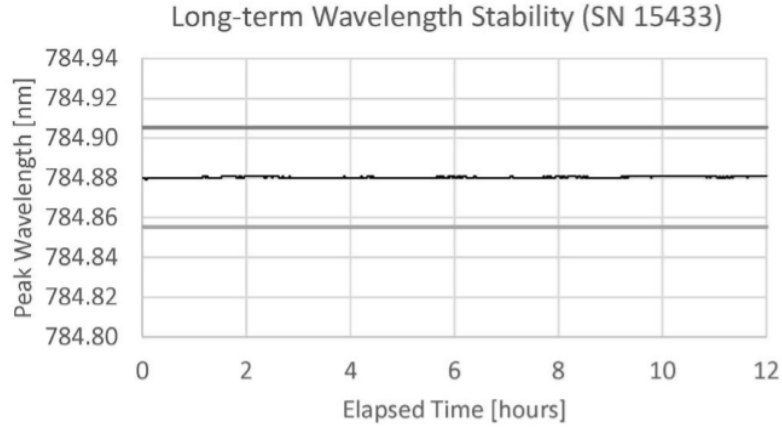

Figure 17: Graph showing the wavelength stability for the IPS laser I0785SD0050PA-IS (permission granted).

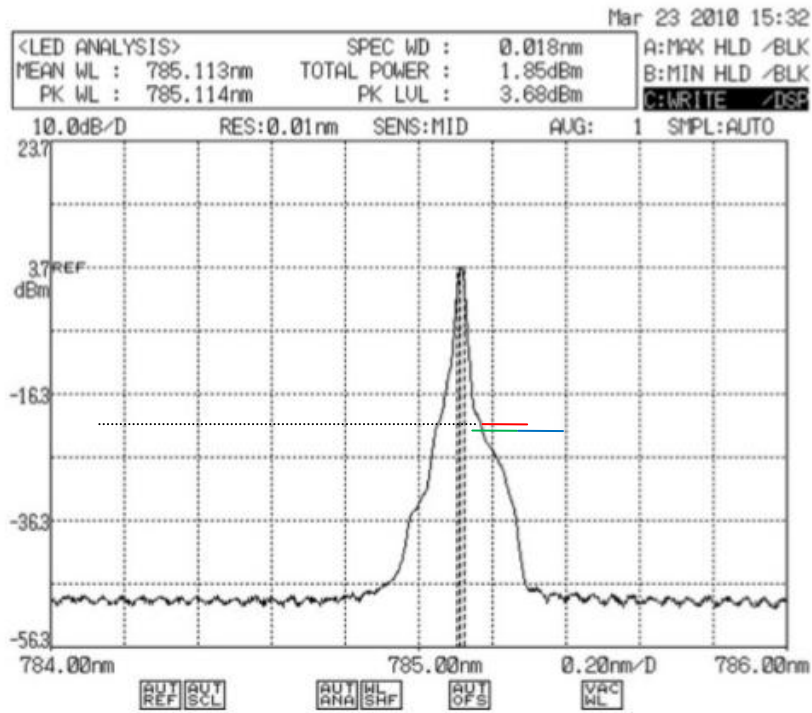

Figure 18: Laser Spectrum for IPS laser I0785SD0050PA-IS.

### 5.2.1.3 Photodiode & Circuit Analysis

One aspect of the project is to allow real time laser power monitoring. This means that we want a way to know what the power of the laser at any given point. One method of achieving this is to split a small percentage of the laser output into a photodiode where 5% percent of the laser can be used to calculate the power and then scaled to adjust to

100% of the laser power. This is done by not only choosing the right photodiode that can be within the 785 nm range, but also choose the right circuit that allows for the photodiode to be in the photovoltaic mode. In order to keep the diode in photovoltaic mode. Photovoltaic mode is a mode when the photodiode is zero biased. This means that the flow of the current coming out of the device is limited which then leads to a voltage being built up. Because of this, the most recommended circuit into dealing with this situation is to use a transimpedance circuit. A transimpedance circuit is simply put, a circuit that converts current to voltage. This is done because the photodiode is producing a current, the circuit then takes this current and converts the output to voltage. Figure 19 shows a typical transimpedance amplifier

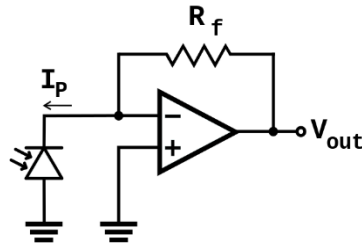

Figure 19: General Transimpedance Circuit

This transimpedance amplifier presents a low impedance to the photodiode and with this singles out it from the output voltage. Because of this, a large valued feedback resistor ( $R_f$ ) is used. Because of this the gain is set by this feedback resistor which has a negative value because the amplifier is in an inverting configuration. Because of this the low level current is converted to a voltage and amplified so that the value can be read. A feedback capacitor can also be used to improve stability.

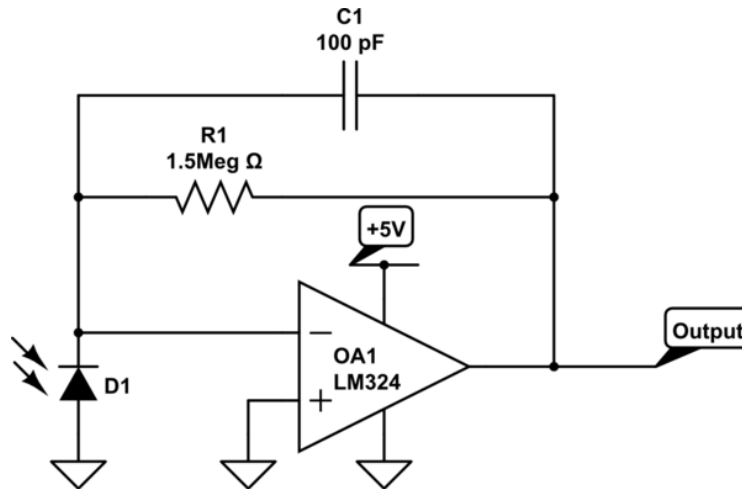
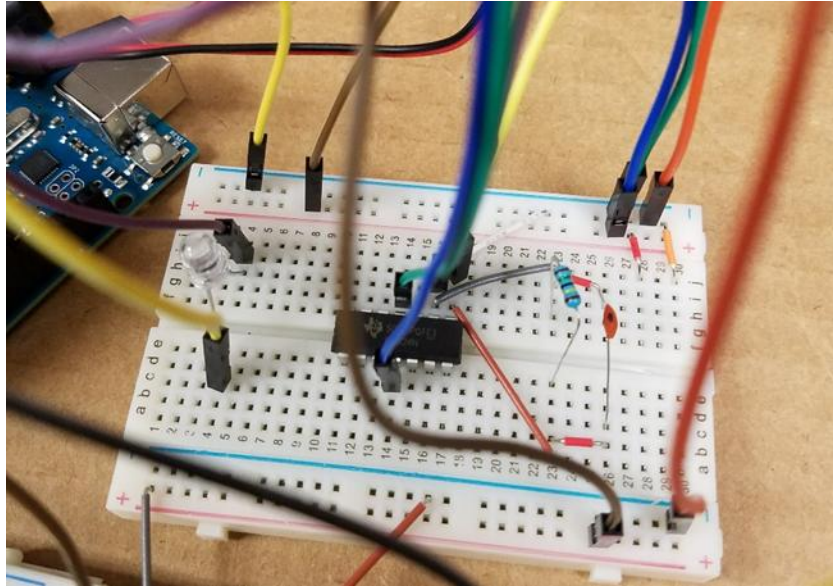

Figure 20: Circuit used for laser power monitoring using a photodiode

Figure 20 shows the circuit built and used. This circuit worked well for the testing and task of the project, though further testing will be done using different op-amps and more capacitors and resistors in different filters for stability and for not hitting the rails depending on how much laser power is going through the photodiode. This is because through testing, ambient light registered at 1v while running a laser light through the photodiode yielded a result of 4.1V which could either mean the photodiode circuit was

working as intended or was hitting the rails of the op amp. Again, this circuit requires further testing. Figure 21 shows this circuit breadboard testing.



**Figure 21: Photodiode Transimpedance Circuit used for Laser Power Monitoring**

## 5.2.2 Volume Bragg Gratings (VBG)

### 5.2.2.1 VBG Theory, Concepts, and Parts

The BragGrate technology of high-efficiency volume Bragg gratings (VBG's) was developed in CREOL. VBG's is based on a periodic refractive index change in a spectral multi-component silicate glass (BragGlass) after exposure to UV radiation followed by thermal development. The glass enables fabrication of phase volume diffractive gratings with absolute diffraction efficiency exceeding 99 % and thermal stability of 400°C. The bragg glass has a laser damage threshold for CW laser radiation in the near IR region at least up to several tens of kilowatts per square centimeter. VGB's can provide narrow spectral selectivity down to 30 pm and narrow angular selectivity down to 100  $\mu$ rad. These elements have low losses and can be used for a variety of applications such as Raman spectroscopy.

Optigrate's bandpass filter is used to narrow the spectral resolution of the laser line. The BragGrate Bandpass filter is a reflecting Bragg grating (RBG) recorded in a bulk of photosensitive silicate glass. The filters are used to clean up laser spectral noise with a bandwidth as narrow as 100 pm in visible and near IR regions. In Raman spectroscopy applications, combining the Bandpass Filters with matching BragGrate Notch Filters enables Raman shift measurements down to 5  $\text{cm}^{-1}$  from the laser line. BragGrate filters have superior environmental stability and can handle high power optical radiation.

The RBG bandpass filter used in this project is designed to reflect and narrow down the wavelength 785 nm. The filter can narrow down the FWHM of a laser line down to 12 nm or less. At a certain input angle, the RBG will reflect the laser light that

has a wavelength of 785 at a different output angle. Other wavelengths incident on the RBG will get transmitted. Two RBGs are provided in the current lab that is provided. Having two RBGs ensure that the spectral resolution of the laser is being reduced. For instance, the FWHM of the laser line is around 0.87 nm and the two RBGs can reduce the FWHM to around 0.12 nm. Each RBG operates at a certain angle. For example, one of the RBGs (Q09-27-A5) has an input angle of  $-5^{\circ}$  and an output angle of  $15.0$ , which is a total of  $20^{\circ}$ . This RBG also has a transmission of 90%. The other RBG (L06-04-B-D2) has an input angle of  $-16^{\circ}$  and an output angle of  $4.0^{\circ}$ , which is a total of  $20^{\circ}$ . Having both RBGs reflect the light at a total of 20 degrees allows for the laser beam to return to its original angle of propagation. For example, if the laser beam is traveling parallel to the floor and is incident on RBG 1 and then RBG 2, a zig-zag shape of propagation path is created. However, when the laser beam is reflected off of RBG 2, it continues traveling parallel to the floor. The transmission of the second RBG is 95%. Since the transmission for RBG 2 is greater than RBG 1, then this RBG should be used to transmit the Raman signal toward the spectrometer because there are less intensity losses.

The figure below shows the alignment setup with the 785 nm laser from Innovative Photonic Solutions and the two RBG's on optical mounts. This setup will be optimized for alignment toward the periscope and then into the microscope. The laser beam from the laser will reflect off the first RBG to narrow the laser line width and then reflect off the second RBG to ensure further that the laser line width is narrowed down. Then the periscope will guide the laser beam into the microscope and then will be focused down onto a sample using the microscope objective to create the Raman excitation.



Figure 22: Optical setup with the 785 nm laser and the two RBG's

### 5.2.3 Photodiode

#### 5.2.3.1 *Light Detectors and Photodiode Theory*

Photodetectors convert a light signal into an electrical signal such as voltage or current by absorbing photons and creating free electron hole pairs (EHPs). The creation of electron hole pairs means a creation of electrons in the conduction band (CB) and holes in the valence band (VB). Photodetectors include photodiodes, photoresistors, and a phototransistor. A photoresistor or photoconductor is a two-terminal semiconductor device which resistance varies with the intensity of the incident light. A phototransistor is a bipolar junction transistor (BJT) that operates as a photodetector with a photocurrent gain. Lastly, a photodiode is a semiconductor device that can operate under reverse bias that can create a current when illuminated with light. Compared to phototransistors and photoresistors, photodiodes has a wider dynamic range in detecting optical power, better linearity, and stability. Photodiodes can detect from picowatts to milliwatts of optical power. For picowatts of light power, photodiodes require a pre-amplifier or an operational amplifier to give signal gain. Photodiodes are also small, light-weight, inexpensive, and have reproducible sensitivity. Phototransistors are more convenient than photodiodes because of its built in gain, which means an operational amplifier would not be necessary for the circuit design. The absorbed light in a phototransistor creates a current in the base region that results in current gains from 100 to several thousands. The built in gain in phototransistors make it popular for applications where there is more than a few hundred nanowatts of available optical power. Unfortunately, compared to photodiodes, phototransistors are limited in its linearity and have variations in its sensitivity. Photoresistors can be designed for measuring microwatts to milliwatts of optical power, which is a small power detectable range when compared to photodiodes. Another disadvantage of photoconductors is the lack of reproducibility in the measured resistance for a given optical power and don't have as strong of a linearity as photodiodes. For this senior design project, photodiodes are used as the light sensor for measuring laser power.

The basic performance of a photodiode is understood by examining a typical pn junction photodiode. When a photon with an energy greater than the bandgap,  $E_g$ , of the semiconductor material is incident on the depletion region of the pn junction, it becomes absorbed to photogenerate a free EHP. The electric field in the depletion later then drifts the EHP in opposite directions to their respective neutral region. An electric field is formed in the depletion region because of the diffusion of minority carriers when combining for instance, a Si doped n-type with a p-type. When combining a n-type and a p-type semiconductor, holes from the p-side diffuse toward the n-side because of a concentration gradient. Once the holes reach the n-side, the holes recombine with the majority carrier electrons in this region, which expose positive donor ions. Also, electrons from the n-side diffuse towards the p-side, recombine with holes, and expose negative acceptor ions. Therefore, an electric field is formed in the depletion layer that points from the positive donor ions to the negative acceptor ions (right to left). When the built in electric field drifts the photogenerated EHP, a photocurrent,  $I_{ph}$ , is formed in the external circuit that provides the electrical signal. The direction of the photocurrent is in the same direction that the holes drift.

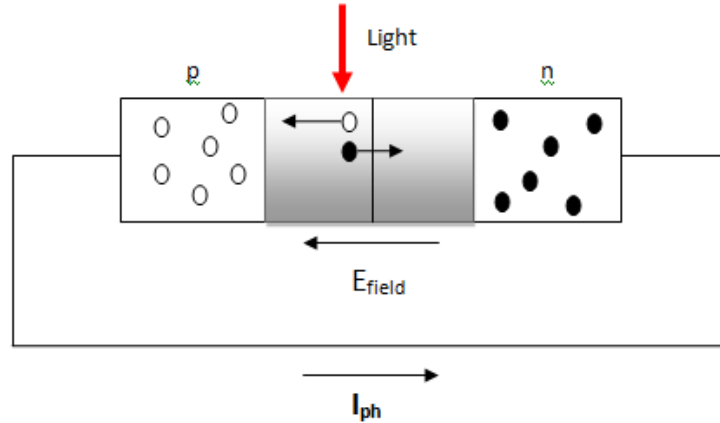

Figure 23: pn junction photodiode

A photodiode can be operated in one of two modes such as the photoconductive or photovoltaic mode. A photodiode operates in the photovoltaic mode when there is no external battery connected to the photodiode, and also functions the same way as a solar cell. In Figure 23, when connecting the photodiode in a closed loop without a voltage source, shining light will generate a photoinduced current in the circuit. In photoconductive mode, a photodiode has a reverse bias applied to its terminals. The advantages of operating in the photoconductive mode include an increase in the depletion width. An increase in the depletion width occurs because the applied reverse bias adds to the built in potential or electric field in the depletion layer. To account for the buildup of charges supporting the increased electric field, the depletion width must increase. A larger depletion width improves the responsivity ( $R$ ) of the photodiode and is defined by the equation below.

$$R(\lambda) = \frac{I_{ph}}{P_{in}} \quad (1)$$

Where  $I_{ph}$  (A) is the photo induced current and  $P_{in}$  (W) is the power of the input light onto the photodiode.

When fast response is needed to detect modulate light at narrow pulse widths or high repetition rates, the photoconductive mode is useful. However, for this project, the laser is not pulsed but is a continuous wave (CW), so having a photodiode with a fast detection is not needed. A disadvantage of the photoconductive mode is an increase in dark current or leakage current and noise.

When a photodiode is operating in the photovoltaic mode, there is no bias voltage across the photodiode's terminals and it functions as a solar cell. Furthermore, the amount of dark current and noise is kept at a minimum when biasing a photodiode in photovoltaic mode.

The figure below shows the I-V characteristics of an ideal pn junction in the dark (blue) and also under illumination (purple). When the pn junction is not illuminated, the I-V characteristics follow the diode equation as shown below.



$$I = I_o \left[ \exp\left(\frac{eV}{\eta k_B T}\right) - 1 \right] \quad (2)$$

where  $I$  and  $V$  are the diode current and voltage as shown in the figure below,  $I_o$  is the reverse saturation current, and  $\eta$  is the ideality factor (not the external quantum efficiency). For the I-V curve below, the reversed saturation current is approximately zero when the pn junction is not illuminated with light. When the pn junction is illuminated with light, the I-V characteristics curve in blue will shift down to the curve in purple until the current in the negative axis is equal to the photoinduced current. The value of the photoinduced current is read from the purple graph when the photodiode is illuminated. If the photodiode is operating in photovoltaic mode, the current and voltage characteristics are shown circled in red. If the photodiode is in a short circuit and is operating in photovoltaic mode, the I-V coordinate is defined by the red circle intersecting the y-axis in the I-V graph. If the photodiode is in an open circuit and is operating in the photovoltaic mode, the I-V coordinate is defined by the red circle intersecting the x-axis on the I-V graph. Obviously, reverse biasing the pn junction and illuminating it with light will create an I-V coordinate point that is found on the third quadrant of the graph shown below.

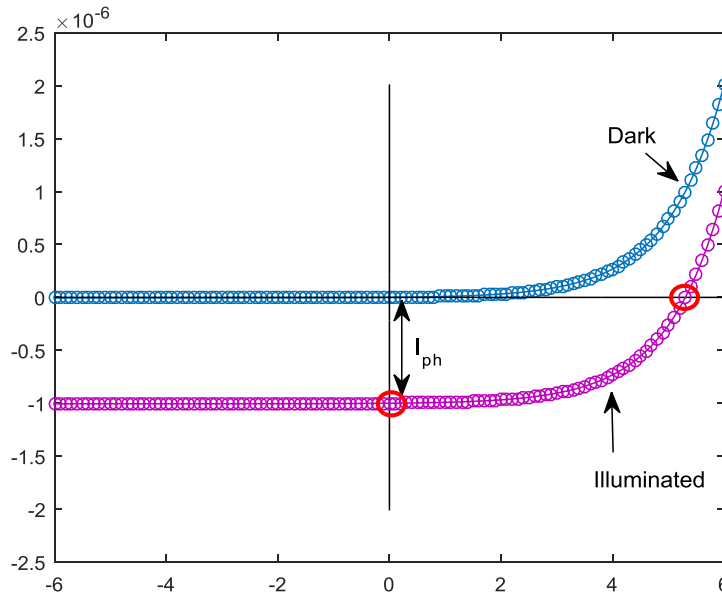

**Figure 24: I-V Characteristics of a pn Junction.**

#### 5.2.3.2 Optical Power Sensing and Calibration

Whether a photodiode is operating in the photovoltaic or photoconductive mode, there is a linear relationship between input optical power and output photogenerated current. Although an optical power meter is too bulky to incorporate in the system, a photodiode is used to measure the power of the laser. The following calibration must be done in order to obtain optical measurements in this system. If for instance, the maximum optical power a photodiode can endure is 25 mW, and the laser is outputting 100 mW,

then a beam splitter or a filter would have to be used to ensure that the optical power incident on the photodiode is not exceeding 25 mW. Once this is taken care of, the following calibration curve can be made and is shown in Figure 25 below.

To create a calibration curve, the following procedure should be followed. The power of the laser should be set at a certain value and read using a separate power meter. At this laser power, the beam should then be incident onto the photodiode so that the photoinduced current can be measured. This procedure is repeated for different values of power so that a linear relationship between laser power and photoinduced current is measured as shown in Figure 25. After the calibration curve is completed and the system is being used, the laser beam will always be incident onto the photodiode. Therefore, for any photoinduced current measured, an optical power value can be determined by using the equation of the linear fit on the calibration curve.

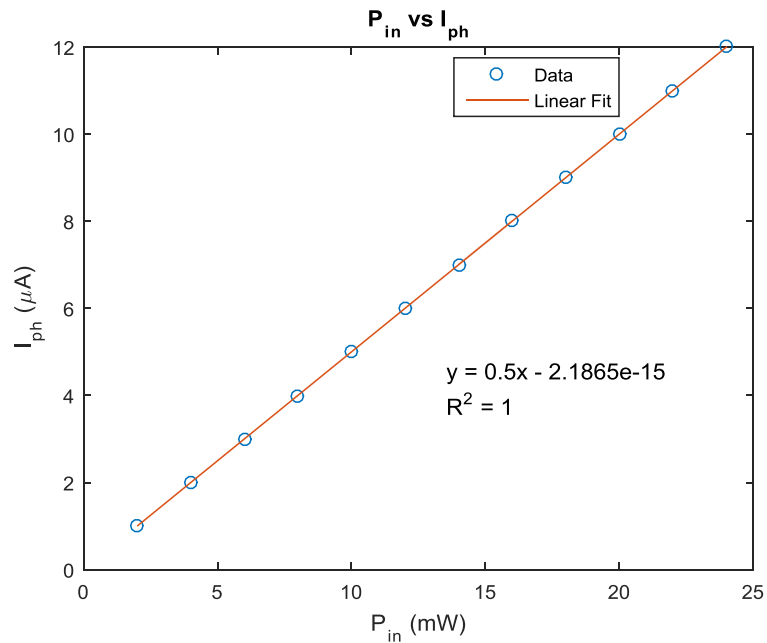

Figure 25:  $P_{in}$  vs.  $I_{ph}$  calibration curve

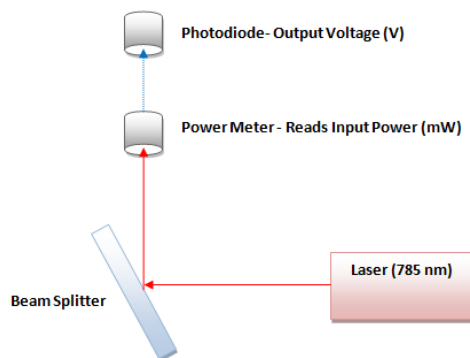

Figure 26: Experimental Setup for creating the Power vs. Voltage Calibration Curve.

It is essential when performing a calibration curve between the laser signal and the photodiode that the relationship is linear because any power value can be determined from the linear fit of the calibration curve. If the points in the calibration curve deviate from linearity, then there will be an error in determining the power of the laser. For instance, Figure 25 shows a coefficient of determination ( $R^2$ ) of 1, which will be used to decipher if a calibration curve strays from linearity. The coefficient of determination explains how well a linear fit explains a set of data points. The closer the coefficient of determination is to 1, the better the linear fit explains the data points. If the coefficient of determination is closer to 0, then the data points cannot be explained by a linear function. Figure 25 shows a linear relationship between the laser power and the photodiode signal, which is fitted to a linear equation ( $y = 2x - 2.1865e-15$ ). The linear equation shown on the graph will be used to determine the laser power for any given signal (current or voltage) provided from the photodiode.

A simple pn junction diode is not sufficient for the laser wavelength used in this senior design project (785 nm) because the depletion width is not big enough for long wavelengths. For long wavelengths where the penetration depth is greater than the depletion layer, the majority of photons are absorbed outside the depletion layer. Outside the depletion layer, there is no electric field to separate and drift the EHPs. Therefore, pn junction diodes have low quantum efficiency (QE) at long wavelengths. The quantum efficiency of a detector is defined by the equation below.

$$\eta_e = \frac{\text{Number of collected electrons at detector terminals}}{\text{Number of incident photons}} \quad (3)$$

A quantum efficiency of 1 means that the detector can convert all the incident photons into electrons and generate current, which is the characteristic of an ideal photodetector. A pin photodiode is used because it has a high quantum efficiency at long wavelengths. The pin refers to a semiconductor device that has the structure  $p^+$ -intrinsic- $n^+$ . The intrinsic layer has much smaller doping than both the  $p^+$ - and  $n^+$ - regions and it is much wider than these regions, typically 5-50  $\mu\text{m}$ . Therefore, the intrinsic region is wide enough to create a high quantum efficiency for long wavelengths such as 785 nm.

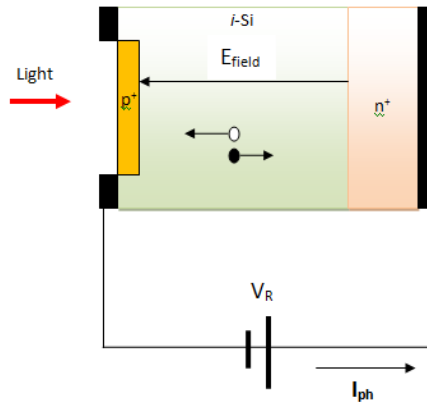

Figure 27: pin photodiode reverse biased for photodetection

Figure 27 shows the structure of a pin photodiode that is reversed bias for photodetection. Since the added intrinsic layer is big enough to detect light with long wavelengths, a photoinduced current is generated when light is incident. The operation of a pin photodiode is identical to an ordinary pn junction. Light absorbed by the detector will generate electron hole pairs that will drift because of the built-in electric field. The drift of EHPs creates the photoinduced current. For a given laser power, it is the photoinduced current that will be read from the photodiode for the calibration curve.

#### 5.2.3.3 *Photodiode Parts Comparison and Specifications*

Different photodiodes were looked at for this project. The main specification the photodiode had to achieve was have a peak sensitivity or responsivity close to 785 nm, since this the wavelength of operation for the laser in the system. The company Thor labs were looked at for photodiodes. The cheapest photodiode on Thor labs' product list that was closest to 785 nm was an FDS 010, which is a silicon photodiode with a broadband detection from 200 nm to 1100 nm. The peak sensitivity and responsivity of the FDS 010 is 730 nm and 0.44 A/W respectively. Although the peak sensitivity is not at exactly 785 nm, the responsivity graph shows that this photodiode can still detect 785 nm. For instance, if the responsivity graph is normalized or each responsivity value as a function of wavelength is divided by 0.44 A/W, it can be seen that the sensitivity is slightly greater than 91 % at around 785 nm. The FDS 010 would work for this senior design project because of its detection capabilities at 785 nm, but the cost is \$43.40. The cost is high because the rise and fall time is 1 ns, which is small. This fast rise and fall time is useful for detecting pulses of light accurately for applications in fiber communications. Of course, in the case of the senior design project, the laser used is not pulsed, but is CW. Spending that amount of money on a photodiode with fast detection capabilities is not necessary.

The second photodiode that was looked at from Thor labs was the FDS 02 silicon photodiode with a broadband detection capability from 400 nm to 1100 nm. The peak sensitivity and responsivity is 750 nm and 0.48 A/W respectively. Compared to the FDS 010, the FDS 02 photodiode is closer to the laser wavelength of 785 nm and has a sensitivity of slightly greater than 93.75 % at around 785 nm. There is a around a 2.75 % increase in sensitivity at around 785 nm in the FDS 02 photodiode compare to the FDS 010 photodiode. Unfortunately, the cost for the FDS 02 is \$75.70, which is \$32.3 greater than the FDS 010. The price is much greater because of the increase in sensitivity in the near IR wavelengths and the smaller rise and fall time. The rise and fall time for the FDS 02 is 47 ps and 246 ps respectively, which is around 1000 times smaller than the FDS 010 diode. The FDS 02 also can be connected with an FC/PC fiber connector, which is suitable for fiber light coupling onto the photodiode. Although the sensitivity for the FDS 02 diode is better than the FDS 010 photodiode, the fast detection capabilities and the compatibility with a fiber connector is not necessary.

The last Si photodiode looked at in Thor labs is the FDS 100, which has a broadband detection from 350 nm to 1100 nm. Compared to the FDS 02 and the FDS 010, the FDS 100 has a peak wavelength further away from 785 nm. The peak wavelength and responsivity of the FDS 100 are 980 nm and 0.60 A/W respectively. At around 785 nm, the sensitivity is slightly greater than 83.3 % and is less than the FDS 010 and the FDS 02 photodiodes. The cost is \$13.50, which is a lot less than the previous

two photodiode looked at. The cost is still high because it has a rise and fall time of 10 ns and this is not needed for a CW laser source.

The photodiode bought for the senior design project is a SFH 213 silicon pin photodiode that has a broadband range from 400 nm to 1100 nm. The SFH 213 photodiode has a maximum sensitivity at the wavelength 850 nm. The spec sheet records a sensitivity of 0.65 A/W at the wavelength 870 nm. Although a photodiode with a peak sensitivity at 850 nm is 65 nm away from 785 nm, the responsivity graph shows that the photodiode still has a good sensitivity at 785 nm. The figure below shows the full responsivity graph for the SFH 213 photodiode and a zoomed in view of the responsivity graph from the wavelength range 700 nm to 800 nm. The zoomed in view of the responsivity graph shows that at around 785 nm, the sensitivity is between 94 % to 98 %, which is a good detection capability for the wavelength needed. The cost for the photodiode is 0.84 cents. The fact that the photodiode is cheap allows for multiple copies of it to be ordered in case it stops working in a circuit. Figure 28 also shows how the SFH 213 photodiode looks.

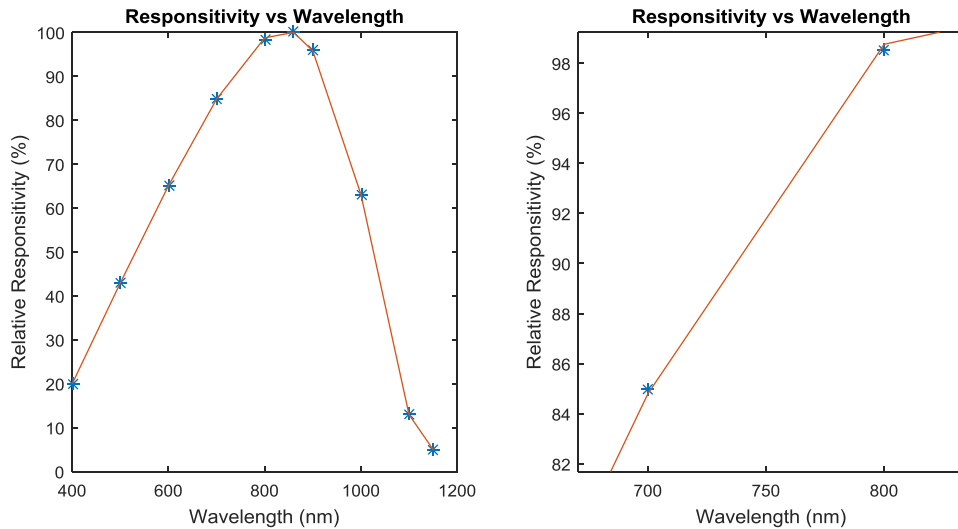

**Figure 28: Responsivity Graph for SFH 213 pin photodiode.**



**SFH 213**

**Figure 29: Picture of the photodiode used in the senior design project (Permission Pending).**

### 5.3 MICROSCOPE

#### 5.3.1 Microscope Specs

The microscope used in this senior design project is an Olympus BH2 and it comes with an attachment that can allow for laser injection, and a camera on top to image the sample. The microscope comes with 4 objective lenses with the specifications shown below. These specifications are important for laser power control and for Raman excitation. For z-axis movement, this microscope has a coarse and fine adjustment knob that move in increments 26 mm and 2  $\mu\text{m}$  respectively. The z-axis allows for focusing for the camera and the laser light.

**Table 6: Specifications of the objective lens on the microscope.**

Magnification	4 X	10 X	20 X	40 X
N.A.	0.10	0.25	0.40	0.65
Focal Length (mm)	34.23	17.69	8.99	4.61

#### 5.3.2 Microscope and System Integration

The Olympus BH2 microscope comes with an attachment with two holes and is shown in the figure below. The top hole with the silver surrounding is for the backing light so that image can be seen clearly through the camera and the eyepiece of the microscope. The second hole with the black surrounding can be used for laser injection.

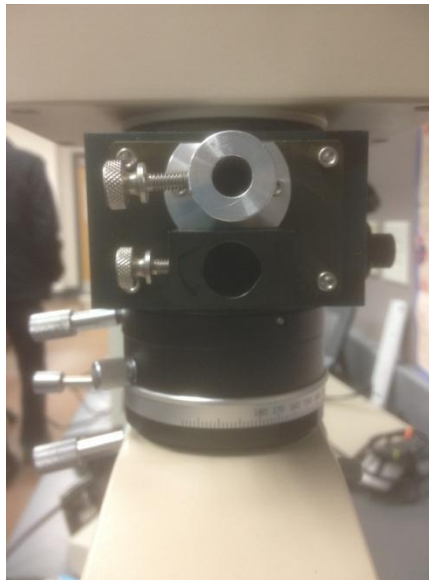

**Figure 30: The two holes for laser injection and backing light.**

The figure below shows what is inside the attachment with the two holes and how the laser and backing light is guided toward the objective lens of the microscope. The illumination source (white line) or the backing light is inserted into the silver cylinder and the light is collimated unto a beam splitter. This beam splitter reflects the backing light onto the objective lens so that a small area of a sample is illuminated. The laser light (red

line) is injected through the black cylinder and reflects off the surface of another beam splitter onto the objective lens. The objective lens focuses the laser light onto a sample to create the Raman excitation. The Raman signal (green line) is then collimated out of the objective lens and is reflected off the beam splitter, into the black cylindrical, and out of the microscope. Once the Raman signal is out of the microscope, it can be collected and analyzed by the spectrometer.

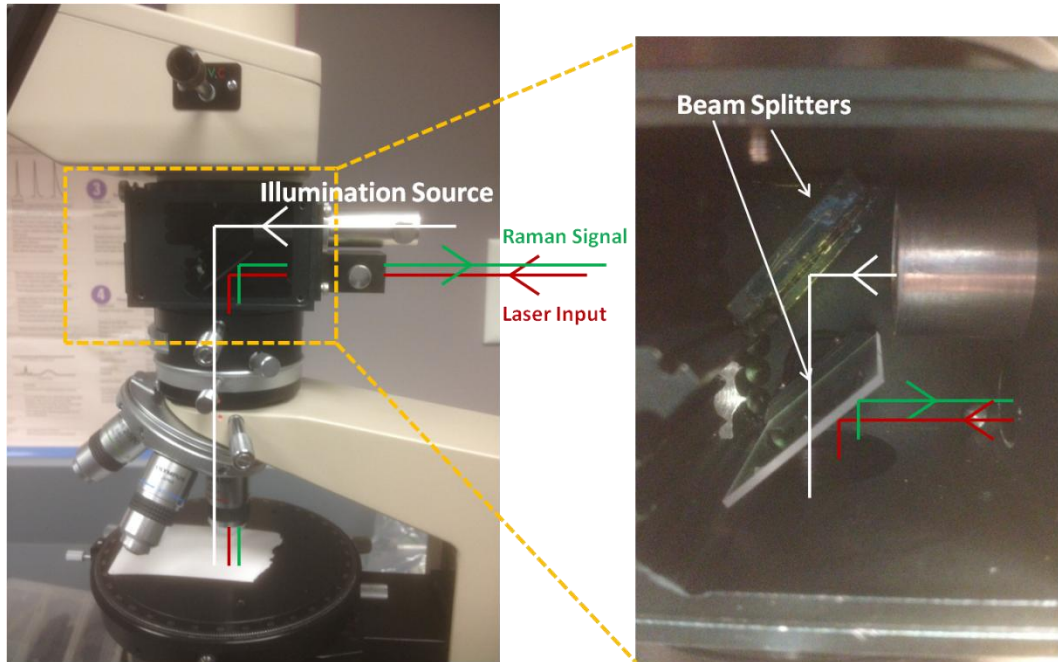

**Figure 31: Microscope attachment with the two holes showing how the light propagates inside.**

Two beam splitters are used inside the microscope to reflect and transmit light. The beam splitter for the illumination source reflects the illumination source, but has to transmit the visible light spectrum so that the camera and eyepiece can see the sample. The beam splitter for the laser light has to reflect the laser wavelength and the shifted wavelengths of the Raman signal, but also transmit the visible light spectrum so that the camera and eyepiece can see the sample.

### 5.3.3 Microscope Camera

The microscope camera is important for seeing the sample and is shown in the figure below on top of the microscope.



**Figure 32: Camera inserted on top the microscope.**

Attached to the camera is another objective lens with a 0.5 magnification. The objective lens attached to the camera allows for the camera to image the sample with a good resolution. The beam splitter on the microscope for the laser is for 532 nm. Therefore, a 532 nm laser is injected into the black hole of the spectrometer to see if an image of the sample can be seen with a laser spot on the sample. The idea is to have a user look at the camera image and know where the laser is creating the excitation on the sample. If the camera can give a reasonable identification of where the laser spot is on the sample, then laser injection with the 785 nm should work. The figure below shows the microscope showing the 532 nm laser being reflected off the surface of the beam splitter and is focused onto the coin with the objective lens.

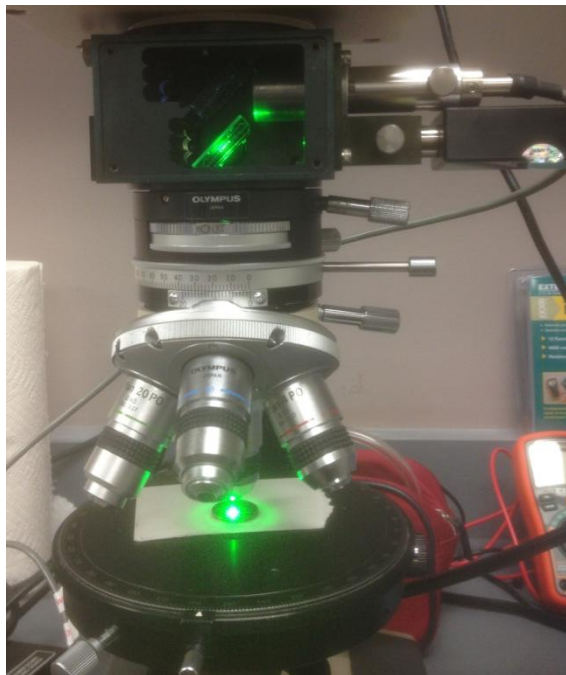

**Figure 33: 532 nm laser injection into the microscope.**

An alignment has to be done with only using the beam splitter. The beam splitter has to be at the right angle so that the full intensity of the laser beam is hitting the coin and this is shown in the figure. Figure 34 below shows a camera image of the sample without the laser on and with the backing light on. It is important to know that the backing light has to be on so that the camera can obtain an image. The figure below also



shows a camera image with the laser on the sample. Originally, the laser spot appeared at the corner of the image. By loosening the top piece of the microscope that includes the eyepiece and the camera and moving it around, the camera image can effectively capture the laser spot. The image below shows the high intensity of the laser beam around its center. If the top piece of the microscope is moved around further, the laser beam can be centered on the image. To obtain a good image, the stage has to be moved in the z-direction until the quality of the image is crisp. A computer software that is compatible with the camera is used to monitor the image as the z-axis of the stage is moved to obtain a good resolution image.

The figure shows that the laser beam illuminates the entire image with light to the point where the features of the sample are not seen. If the 785 nm laser is less intense than the 532 nm laser, then some of the features of the sample can be seen through the camera when the laser is on. The approach is to have the laser turn off or operate at low power when using the camera to image the features of the sample. In the image below, the 532 nm laser was being operated at full laser power, which is why the laser intensity is bright enough to hide the features of the sample on the camera image.

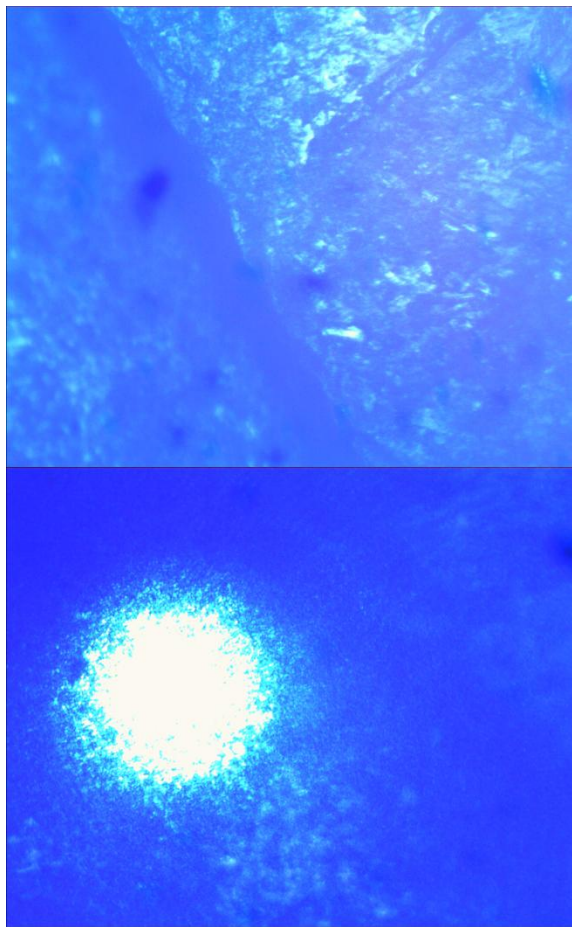

**Figure 34:** Camera image on the left is of the coin and the image on the right is the image of the laser beam on the sample.

#### 5.3.4 Microscope Beam Splitter

The figure below shows a picture of the beam splitter that is used inside the microscope to reflect the laser line.

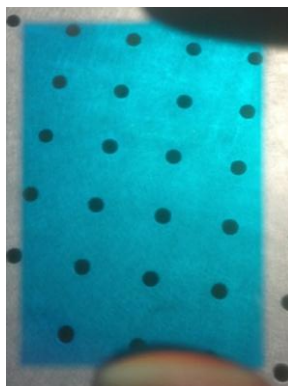

**Figure 35: Beam Splitter in the Microscope for the 532 nm laser line.**

Since this beam splitter reflects light around 532 nm and it is a long wavelength pass filter, then wavelengths below 532 nm are transmitted. Wavelengths below 532 nm are blue light, which is why when looking through the filter in the figure blue light is seen. Furthermore, when looking at the image through the camera, a blue image is seen.

If the laser wavelength that is going to be used in this project is 785 nm, then the current beam splitter in the microscope will have to be replaced because it only reflects around 532 nm. If the full intensity of the 785 nm beam needs to be reflected toward the objective lens to create the Raman excitation, then a beam splitter will have to be bought with specs that reflects around 785 nm. Semrock is the company that provided the 532 nm beam splitter, so this is the company that will be used to find a beam splitter for 785 nm. Two beam splitters are looked at, one of which is a 749 nm single-edge short-pass dichroic beamsplitter. This beam splitter has an average of around 96 % reflection from 770 - 1100 nm and around 93 % transmission around 400 - 730 nm. The wavelength reflectance range of this beam splitter includes the 785 nm wavelength, so the laser wavelength can be reflected. In terms of the Raman signal wavelength, the spectral range that is going to be designed for the spectrometer to detect is at least  $\pm 200 \text{ cm}^{-1}$  or  $\pm 12.52 \text{ nm}$ . Therefore, the beam splitter will have to reflect a Raman signal from 772.48 nm to 797.52 nm, which is in the wavelength range that the 749 nm single-edge short-pass dichroic beamsplitter reflects. An advantage of the 749 nm beamsplitter is that it transmits the majority of the visible light spectrum, which would not make the camera image blue as before, but would contain more visible light.

The second beam splitter is the 725 nm single-edge short-pass dichroic beamsplitter. This beam splitter has about a 90 % reflectance at 750 nm to 1140 nm and about 90 % transmission from 430 nm to 700 nm. This beam splitter will still pass the visible light spectrum, but losses 30 nm of visible light when compared to the 749 nm beamsplitter. Having some wavelength loss in transmitting the visible light spectrum will cause the camera image to show less visible light colors. In this case, there will be less blue colors in the camera image. An advantage of this beam splitter is that a wider range of near infrared wavelengths can be reflected, which means that a wider range of Raman

shifts can be directed out of the microscope. Unfortunately, the percentage of reflection and transmission of the 725 nm beamsplitter is smaller than the 749 nm beamsplitter. For instance, for the 725 nm beamsplitter, 90 % of the light is reflected toward the object lens and another 90 % of the Raman signal will be reflected out of the microscope. Therefore, there will be a total of a 81 % loss in the Raman excitation signal. For the 749 nm beamsplitter, 96 % of the laser beam is reflected into the objective lens and 96 % of the Raman signal is reflected out of the microscope. The total loss of the Raman excitation signal is about 92.16 %. There is almost a 10 % difference in light intensity losses between the 725 nm beamsplitter and the 749 nm beam splitter. It is important that the intensity of the Raman signal is kept as high as possible so that the spectrometer can have an easier time detecting and displaying the spectrum. If there is a beamsplitter that worsens the Raman signal, then it should not be used. The beam splitter that will be bought for this senior design project is the 749 nm beamsplitter.

The transmission spectrum of the current beam splitter in the microscope is shown below. The transmission spectrum is taken because the exact specifications of the beam splitter is not known and this beam splitter might still be reflective from 770 nm to 800 nm. This test was ran by shining a lamp source with a broadband wavelength from 200 nm to 900 nm at through a fiber to the beam splitter at normal incidence. Then the transmitted light is collected using another fiber, which is connected to an ocean optics spectrometer. The resultant transmission spectrum is shown below. The transmission spectrum below shows close to a 100 % transmission 350 nm to 540 nm and then almost 0 % transmission (close to 100 % reflection) from 500 nm to 700 nm. Since the spectral range we are designing the spectrometer to detect is from 770 nm to 800 nm, this is the region of interest that the lowest amount of transmission is desired. Unfortunately, from the transmission below, from 700 nm to 900 nm, there is a high percentage of transmission. Especially from 750 nm to 850 is a transmission around 60 %. This is not desirable for this Raman system because a beam splitter is need to reflect a 785 nm laser light to the objective lens and reflect Raman light from 770 nm to 800 nm toward the spectrometer.

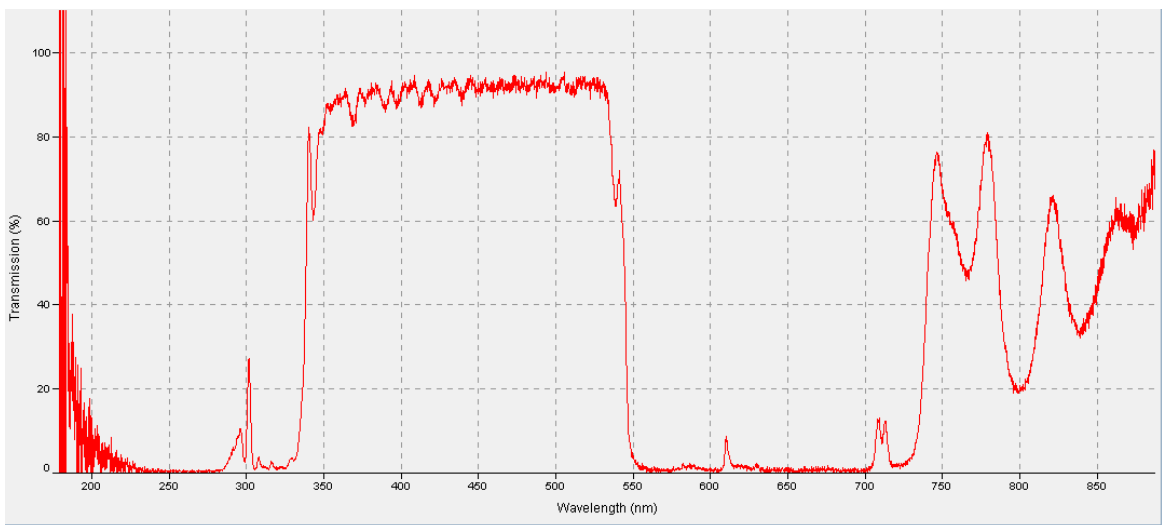

**Figure 36: Transmission spectrum of the beam splitter in the microscope.**

### 5.3.5 Periscope

The purpose of the periscope is to guide the laser beam toward the hole of the microscope. Since the microscope hole is at an elevated position with respect to the optics, then 2 mirrors can be used to guide the laser beam to an elevated position. Mirrors were initially looked at from the company Edmund optics, which is a 25.4 mm diameter near infrared precision broadband laser mirror. The mirror is big enough to reflect the beam width of the laser and has a surface flatness of  $\lambda/20$ . Surface flatness is a type of surface accuracy specification that measures the deviation of flat surface such as that of a mirror, window, prism, or plano-lens. This deviation can be measured using an optical flat, which is a high quality, highly precise flat reference surface used to compare the flatness of a test piece. An optic with a bad rating on surface flatness will introduce some wavefront distortions, which are responsible for aberrations and bad quality focus.

To measure surface flatness, the concept of peak-to-valley is used, which is the difference between the "highest" and "lowest" parts on the surface of the optic. This is the most widespread quality control in industry. Another measurement is the RMS (Root Mean Square) value of the flatness. This technique involves measuring a substantial amount of the optic's surface at many points and then calculating the standard deviation of the surface from the ideal form. An optical system with a  $\lambda/3$  RMS deformation will have the power at the focus reduced to approximately 3 % of its theoretical power. The wavefront distortions cause a drop in power because some interferences are created in the focus. Interference results from light arriving at different phase. The table below summarizes the surface flatness (peak-to-valley) value and its impact.

**Table 7: Surface flatness, quality, and applications.**

Surface Flatness	Quality	Applications
Less than $\lambda/2$	Very low	Non critical divergent applications only
$\lambda/4$	Low	Best Standard for cube beam splitter. Not suitable for high power applications or when wavefront control is important.
$\lambda/10$	Good	General Standard for quality manufacturer. Suitable for most laser and scientific application.
$\lambda/20$	Very Good	Critical wavefront control applications such as interferometry or intense femto-second lasers.

The mirror from Edmund optics has a surface flatness of  $\lambda/20$ , which is too much flatness for the application in this senior design project. Having a mirror closer to an ideal flat surface is mostly for interferometry applications because there is little distortion in the wavefront. The mirror reflects in the wavelength range 700 nm to 900 nm, which will reflect the laser wavelength 785 nm. The spectrometer is designed to detect a Raman signal from 770 to 800 nm and this mirror will be able to guide these wavelengths toward the spectrometer. Unfortunately, because of the qualities such as the surface flatness

being  $\lambda/20$ , and the mirror having reflection in the near IR, the price of this mirror is \$125 and since the project needs two, the total will be around \$250.

Thor labs is another company that sells mirrors. The type of mirror looked at from this company is the fused silica broadband dielectric mirror with a size of 1 inch. Two of these mirrors are suitable at reflecting light at the desired wavelengths. The E02 mirror has a listed reflection band from 400 nm to 750 nm, but when looking at its reflection plot, it has more than 98 % reflection past 750 nm up until 900 nm. This mirror achieves the desired reflection band from 770 nm to 800 nm. The surface flatness is  $\lambda/10$ , which is well-suited for most laser applications. The price is \$75.10, which is a lot cheaper than the mirror from Edmund. The E03 mirror has a broadband 99 % reflection from 750 nm to 1100 nm, which is in the desired wavelength range from 770 nm to 800 nm. The surface flatness is  $\lambda/10$  the price is \$75.10 as well. Overall, wither the E02 and E03 mirror would work for this senior design project because it reflects in the desired broadband range, has a good surface flatness, and is cheaper than the mirror from Edmund. Two of these mirrors will cost around \$ 150, which is only \$25 less than one mirror from Edmund.

## 5.4 SPECTROMETER

### 5.4.1 Spectrometer Overview

After the excitation laser has undergone a Raman shift, the resulting spectrum must be analyzed using a spectrometer. The purpose of the spectrometer is to determine what wavelengths of light result from the excited sample. There are numerous ways the spectrometer can be designed, but the design depends greatly on the spectrum being analyzed.

In order to measure Raman scattering, the spectrometer must measure a relatively small portion of the spectrum with high resolution. The desired spectral range of the spectrometer is  $\pm 200$  wavenumbers, which is approximately 25.04 nm, while the resolution must be less than  $5 \text{ cm}^{-1}$ , or 0.31 nm. The spectrometer must be able to conform to these specifications, but there are other considerations to take into account.

Ease of implementation is a major factor when considering the type of spectrometer. Some spectrometers contain many intricate parts that must be designed and implemented very carefully. If the spectrometer is too difficult to construct and align, then a different type of spectrometer might be required. Ideally, the spectrometer should be as simple as possible while still able to achieve the desired resolution and spectral range.

Another major consideration is cost. Spectrometers have many optical components, which means that the cost can rise very quickly. However, some spectrometers may require high precision components, which can drastically increase the cost. Once again, the spectrometer should be designed to be as inexpensive as possible.

### 5.4.2 Design Considerations

#### 5.4.2.1 *Fourier Transform vs. Dispersion Spectrometers*

There are two main categories of spectrometers, and each type has its own advantages and disadvantages. Dispersion spectrometers use a dispersive element to separate

individual wavelengths of light, while Fourier Transform (FT) spectrometers use interference patterns to measure the spectrum.

Dispersion spectrometers come in many varieties, but most operate on the same basic principle. A dispersive element is used to bend light chromatically, which results in certain wavelengths of light bending more than other wavelengths. This effectually spreads the light into its spectrum, which can be collected with any light-sensitive detector.

The two main types of dispersive elements are prisms and gratings. A prism is simply a wedge of glass, usually in the shape of a triangular prism. As light refracts through the prism, shorter wavelengths are bent more sharply, resulting in dispersion. However, it is difficult to focus on a small portion of the spectrum with high resolution without using very large and very expensive prisms.

Gratings offer several advantages over prisms. While prisms are often large, heavy blocks of glass, gratings are much smaller, often only a thin film. This allows spectrometers to be much more compact, which can lead to narrower spectral ranges and higher resolutions. Additionally, gratings are often much cheaper to manufacture than an equivalent prism. As a result, prisms are rarely used in modern spectrometers.

An FT spectrometer does not use dispersion to obtain a spectrum. Instead, the sample is analyzed using a Michelson interferometer. The interference pattern (interferogram) is measured as the mobile mirror moves in discrete jumps. These interferograms are then processed using a Fourier transform, resulting in the spectrum. The spectral range is dependent on the distance the mirror moves between measurements, with smaller movements resulting in larger spectral ranges. The resolution is inversely related to the total distance the mirror moves during the measurement process.

FT spectrometers can offer very high resolutions, but are much more difficult to design than dispersion spectrometers. The mobile mirror must move very small, regular distances, on the order of hundreds of nanometers, which requires a highly calibrated step motor. Additionally, the mobile mirror must remain perfectly aligned as it is moving, and any vibrations can ruin the analysis.

In order to determine which type of spectrometer should be used for Raman spectroscopy, the advantages of each should be analyzed. FT spectrometers offer very high resolution, but are much more expensive and difficult to design. Also, FT spectrometers are generally more useful when large spectral ranges are required, which is not the case with Raman spectroscopy. Dispersion spectrometers allow much smaller spectral ranges to be analyzed, and are much easier to design, while still being able to obtain the necessary resolution. Finally, the optics in a dispersion spectrometer are much cheaper than the precision elements found in FT spectrometers. Thus, for Raman spectroscopy a dispersion spectrometer is the most feasible option.

#### 5.4.2.2 *Monochromator vs. Spectrometer*

While the basic design of dispersion spectrometers is fairly standard, there are two main designs that can be used. These two main designs are monochromators and spectrometers. Each one offers its own advantages and disadvantages with regards to the spectral range and resolution.

In a monochromator, the grating is attached to a step motor. Additionally, a single pixel detector is used. As the grating is rotated, the spectrum is moved across a pinhole in front of the detector, which reads the spectrum one pixel at a time. The pinhole blocks all but a very small portion of the spectrum, allowing only a single wavelength of light to encounter the detector. Because the spectrum is read pixel by pixel, it can take a long time for the entire spectrum to be measured.

A spectrometer uses a fixed grating, and the spectrum is read by an array of detectors. This array measures the entire spectrum in a single reading. Spectrometers allow for instantaneous reading of the entire spectrum, which can possibly help to eliminate errors during the analysis of the spectrum.

In a monochromator, the spectral range is limited only by how far the grating can rotate, resulting in large spectral ranges. However, the resolution is limited by the smallest rotation allowed by the step motor. In order to obtain high resolutions, a highly calibrated, small-step step motor must be used. As a result, monochromators usually have large spectral ranges and low resolution.

The spectral range and resolution of a spectrometer is mostly dependent on the detector and the grating used. The spectral range is determined by the length of the array, with longer arrays resulting in larger spectral ranges. The resolution is based on the pixel density, with higher densities resulting in higher resolutions. Additionally, there is an inverse relation between resolution and spectral range.

In order to measure the Raman signal, a small spectral range must be measured with high resolution. While a monochromator would be able to achieve the necessary resolution, it would be much more difficult and expensive to design, because the step motor would have to be very precise. A fixed grating spectrometer would be much cheaper, and the lack of moving parts makes it much easier to implement. Also, because of the inverse relation between resolution and spectral range, it is much easier to get high resolutions with a small spectral range, which is perfect for measuring Raman scattering.

#### 5.4.3 Design Overview

A basic schematic of the spectrometer is shown in Figure 37. It shows the various components used in the spectrometer, which will be discussed in later sections.

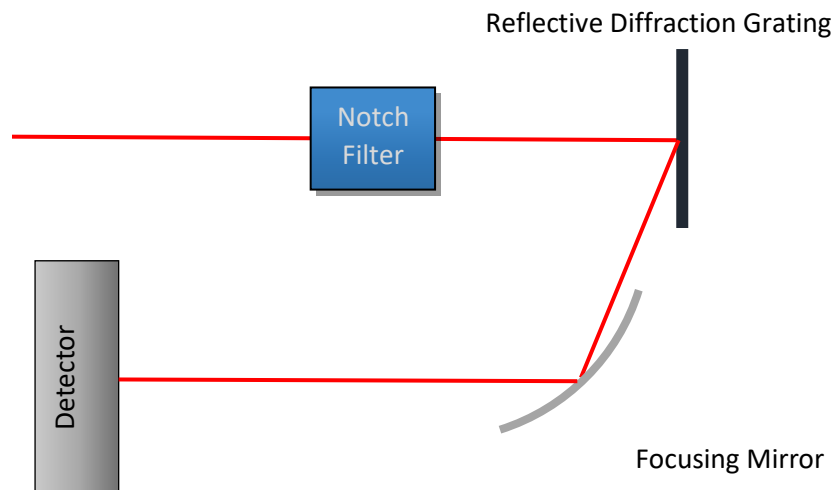

**Figure 37: Basic Spectrometer Design**

While many spectrometers use a pinhole or a slit at the entrance of the spectrometer, it is not necessary for our design. The purpose of the pinhole is to diffract the light, which is collimated with a mirror onto the grating. This spreads the light over a greater surface of the grating, which allows for a higher resolution. However, because the Raman signal is likely very weak, a pinhole would create significant loss of the signal, possibly making it impossible to detect. The loss in resolution can also be compensated for with a higher density grating.

The Raman signal first enters the notch filter, which is intended to filter out the laser line at exactly 785 nm. This is necessary, because the laser line is much higher in intensity than the Raman scattered light. Without the notch filter, the laser line would overpower the detector, making it nearly impossible to measure the Raman signal.

The purpose of the diffraction grating, as described in Section 5.4.2 and elaborated in Section 5.4.5, is to cause dispersion in the Raman signal. This separates the signals from the Raman scattering, which allows the different signals to be read by the detector.

The focusing mirror takes the dispersed Raman spectrum and focuses it on the detector. The signal coming from the grating is collimated, so the detector should be placed at the focal point of the lens.

The specifications for each component must be determined in order. First, a detector array must be chosen as the starting point. The specifications of the grating and the curved mirror can then be determined. The process for determining these specifications are detailed in the following sections.



#### 5.4.4 Detector

##### 5.4.4.1 Detector Specifications

The detector is actually an array of CCD detectors. Aside from the grating, the detector array is one the main determining factor in the resolution of the spectrometer. The detector must have enough pixels to obtain the resolution required.

The minimum resolution required by the spectrometer is  $5 \text{ cm}^{-1}$ , while the spectral range is  $\pm 200 \text{ cm}^{-1}$ . This corresponds to a minimum resolution of 0.31 nm and a spectral range of 25.04 nm. The minimum number of pixels required in the detector is the spectral range divided by the resolution, which gives 81 pixels. However, the spectrometer's resolution should ideally be limited by the grating. This is achieved when the resolution of the detector is higher than the resolution of the grating, so the detector should have as high a resolution as possible. This corresponds to a pixel count much higher than the 81 pixels necessary for the minimum resolution.

The detector used in the spectrometer is the Toshiba TCD1304AP, which is shown in Figure 38. It is a linear CCD detector array in an integrated circuit (IC), which allows easy integration into the PCB. The array contains 3648 pixels. If the spectrometer's resolution was limited by this detector, the resolution would be the spectral range (25.04 nm) divided by the number of pixels, giving a resolution of 6.86 pm. This is much higher than the minimum resolution of 0.31 nm. However, the actual resolution will be limited by the grating, which will be explored in Section 5.4.5.



**Figure 38: TCD1304AP CCD Linear Detector Array**

Each pixel is 8 microns wide, with a total array length of 29.1 mm. This length will be used to determine the grating and mirror specifications.

##### 5.4.4.2 Detector Integration

In order to actually use the TCD1304AP CCD detector, a circuit must be built allowing a voltage output to be read, but this voltage output must have a decent range for the resolution the spectrum that Raman spectroscopy must be used in. The detector as well must be driven by the clock and also read from the ADC so that data can be fast. In order to achieve this, a circuit was built understanding these characteristics and utilizing

the detector, but also the rate at which the Arduino can process data. The figure below shows the general circuit that was used to read data from the TCD1304 from an Arduino.

In simple terms, the analog output of the CCD detector is being buffered by the 2N3906 pnp transistor, and the op amp is used to amplify the gain. Once this is done, the signal that is passed into the Arduino Uno's analog pins is interpreted as 800, 10-bit readings. The details of the circuit is that the pnp transistor being used is a buffer for the high impedance signal output of the TCD1304. Because of this a LM324 is configured as an inverting amplifier, but because there is a variable resistor on pin 12 of the LM324, the circuit then becomes a difference amplifier. This is done because the output of the CCD detector is a positive signal that is less than 5V. The variable resistor can be used to either make the CDD output drop in the presence of light as the light increase by setting the variable resistor as 2k or making the CCD output rise in the presence of light as it increase by dropping the variable resistor to a setting where the CCD detector is in the dark for calibration and setting the variable resistor to an ohm value that allows the CCD output to be close to 0 but a tad higher. This then allows the output to raise in as light intensity goes up.

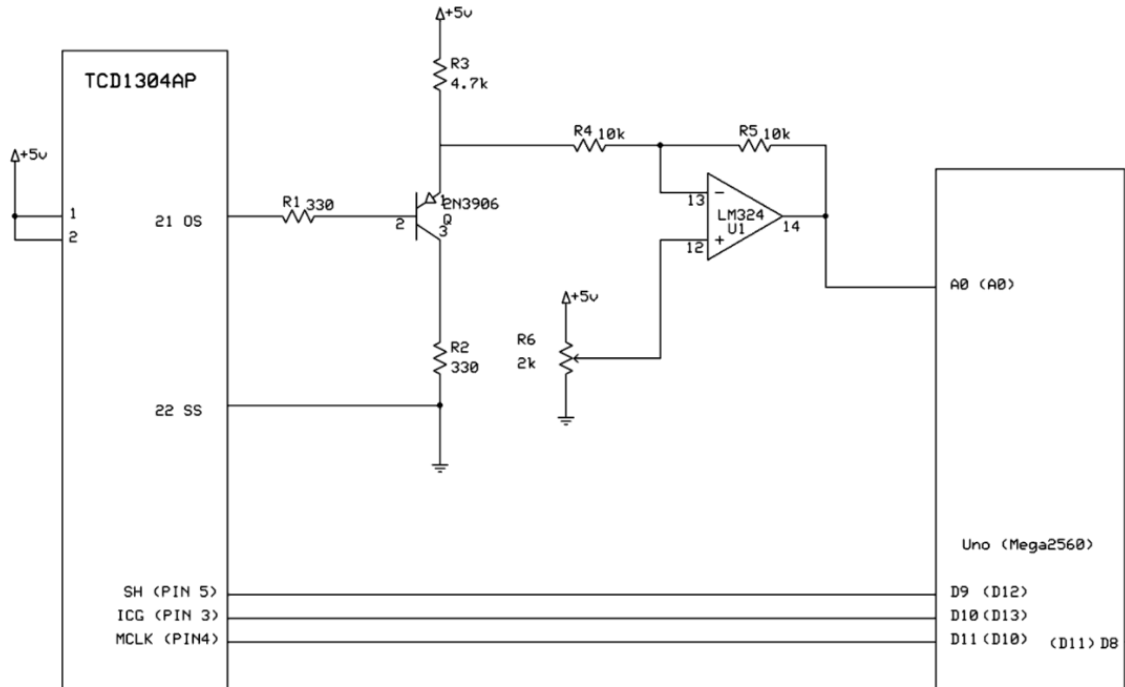

Figure 39: Circuit for using a TCD1304 with an Arduino Uno (permission granted from DaveAllmon)

Now the PNP transistor voltage can be read from the emitter of the PNP transistor directly, where calculations can be done to get the light value from the CCD detector, but this would limit the range that can be produced. This is why the LM324 is there acting as a difference amp because this allows the gain provided by the LM324 to be a gain of x2. One design difference that was incorporated and still is being test is the use of allowing the LM324 gain to increase for a wider range is by changing the value of R5 from 10k to something like 30k. This would allow the gain to increase, but this would also increase

the noise on the output. Regardless, this circuit works perfectly as needed and reads 800 readings with a 10-bit resolution.

The SH, ICG, and MCLK of the TCD1304 are hooked up to the Arduino because the line readout consists of driving the clocks and reading the output for allowing speed to occur when using the TCD1304 CCD detector. Because of this, the MCLK can be configured so that the 3684 pixels are outputted as 800 data readings, but can be adjusted accordingly.

#### 5.4.5 Grating

Gratings used in spectrometers are either transmission gratings or reflection gratings. Functionally, they are very similar. When light is incident on the grating, it is dispersed depending on wavelength. However, transmission gratings allow the light to pass through them, while reflection gratings act as a mirror. Reflection gratings generally allow for more compact designs, making them preferable over transmission gratings.

The resolution of a grating is determined by the number of grooves in the grating, which is determined by the line density. The number of grooves required to resolve a signal can be calculated by dividing the wavelength of light (785 nm) by the resolution (0.31 nm). This results in 2533 lines, which is the minimum number of grooves that the incident light must cover. Higher resolutions are obtained by increasing the number of grooves.

There are two ways to increase the number of grooves used by the spectrometer. The first is by increasing the line density. The other way is to increase the spot size on the grating. Generally, the line density of the grating is limited to what is available on the market, so the most effective way to increase resolution is by increasing the spot size. Ideally, the spot size should be as large as possible in order to get the best resolution possible.

There are six readily available options for a reflection grating at 785 nm from Edmund Optics. Table XX compares these gratings, along with their resulting resolution and cost.

**Table 8: Analysis of Resolution and Cost of Available Gratings**

Line Density (lines/mm)	Grating Dimension (mm x mm)	Max Resolution (nm)	Cost
600	12.7 x 12.7	0.103	\$64.40
	25 x 25	0.052	\$105.00
	50 x 50	0.026	\$185.00
1200	12.7 x 12.7	0.052	\$64.40
	25 x 25	0.026	\$105.00
	50 x 50	0.013	\$185.00

The cost of the grating is dependent on the size and not the line density, so the best option is to use the 1200 lines/mm grating. Additionally, there is no need to get a

grating larger than 12.7x12.7 mm, since a resolution of 0.052 nm is much higher than the minimum requirement. Thus, the 1200 lines/mm, 12.7 x 12.7 mm grating is the ideal choice.

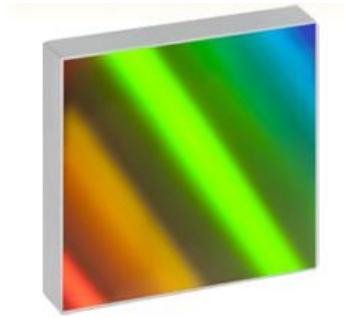

**Figure 40: Diffraction Grating**

The incident light will be normal to the surface of the grating, which means the angle of dispersion can be calculated with Equation XX.

$$\theta_d = \sin^{-1}(\lambda * d)$$

$\lambda$  is the wavelength of light and  $d$  is the line density (1200 lines/mm). Using 785 nm as the central wavelength, solving this equation for the angle gives  $70.4^\circ$ , which is the angle the reflected light will make from the incident light.

The dispersion of the grating is provided by the manufacturer. For a grating with a line density of 1200 lines/mm, the angular dispersion is  $1.35 \times 10^{-3}$  rad/nm. This value will be used to calculate the focal length of the focusing mirror in 5.4.7.

In order to increase the efficiency of the dispersion, the grating has been blazed. All gratings have different orders of dispersion, which means that a single beam incident on the grating will be dispersed in multiple directions simultaneously. This lowers the amount of light that can be captured by the detector, which decreases signal quality. Blazing is a technique that ensures most of the dispersion only occurs in a single order. According to the manufacturer, the blazing on this grating has approximately 80% efficiency at 785 nm, which means that 80% of the incident light is directed into the detector.

#### 5.4.6 Mirror

The purpose of the mirror is to focus the light from the grating onto the detector. Specifically, it converts the angular dispersion from the reflection grating into a linear dispersion. The linear dispersion can be calculated using Equation XX.

$$L = fD$$

$D$  is the angular dispersion of the grating, which is given by the manufacturer, and  $f$  is the focal length of the mirror. Thus, the focal length of the mirror can be calculated using the linear dispersion, which is based on the length of the detector.



**Figure 41: Example of Linear Dispersion**

From the data sheet for the detector, the length of the detector array is 29.1 mm. The linear dispersion is simply the length of the array divided by the spectral range (25.04 nm), giving a linear dispersion of 1.162 mm/nm. Plugging this value into Equation XX, along with the angular dispersion of the grating ( $1.35 \times 10^{-3}$  rad/nm), the focal length can be determined to be 860.84 mm.

Due to limitations in commercially available concave mirrors, the nearest focal length available is 762 mm. However, using a shorter focal length may actually be better, since it effectively increases the spectral range. Using this value for the focal length gives a linear dispersion of 1.03 mm/nm and a spectral range of 28.3 nm, or  $\pm 225.23 \text{ cm}^{-1}$ .

The mirror should not affect the resolution of the spectrometer. Resolution is primarily dependent on the detector array and the grating.

#### 5.4.7 Spot Size Magnification

The Raman signal obtained from the microscope has a small spot size. In order to increase the resolution of the spectrometer, the spot size should be increased. This can be done with a simple 2-lens magnifier, as shown in Figure 42.

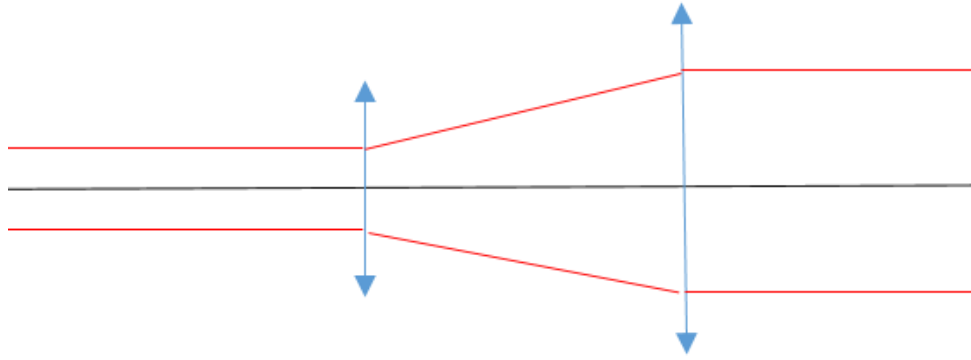

**Figure 42: Magnifier Design**

The first lens is a concave lens, which diverges the collimated beam. The second lens recollimates the beam, but with a larger spot diameter. This magnifier requires that the focal points of the two lenses overlap.

If the spot size of the Raman signal is 2 mm diameter, the resolution is 0.33 nm, which is not high enough for our specifications. However, if the diameter of the spot is increased to 10 mm, the resolution is increased to 0.065 nm, corresponding to  $1.05 \text{ cm}^{-1}$ . Thus, a magnification of 5 is enough to get the desired resolution. The magnification is equal to the focal length of the second lens divided by the focal length of the first lens.

If the focal length of the concave lens is set at 15 mm, then the focal length of the convex lens is 75 mm. This results in a separation of the lenses of 60 mm, and a magnification of 5.

#### 5.4.8 Notch Filter

The output signal from the microscope contains both Raman scattering and the original laser wavelength. The Raman signal is typically very weak in comparison to the laser, and is difficult to detect. A specifically designed notch filter can selectively remove the laser line, allowing the Raman signal to be observed.

In order to effectively remove the laser line, three different notch filters will be used. The specs for these notch filters is shown in Table XX.

**Table 9: Specs for Three Notch Filters**

Filter	Design Wavelength	Spectral Selectivity	Transmittance	Input Angle	Output Angle
		FWHM	At DW	At DW	
NF1	785 nm	<0.6 nm	>88%	-5.9	5.6
NF2	785 nm	<0.6 nm	>93%	-5.9	6.2
NF3	785 nm	<0.6 nm	>93%	-5.9	6.2

Ideally, the notch filters won't completely neutralize the laser line. It is actually useful to have a small signal from the laser line, which can be used to calibrate the spectrometer. The laser line, at 785 nm, should be centered on the detector. It is much easier, both for alignment and calibration, if the laser line is still present.

The notch filters are not designed to work with normally incident light. Instead, the incident light must be at a slight offset from the normal. The spec sheet for this notch filter indicates that the offset for the incident beam should be approximately  $5.9^\circ$  from the normal. A diagram for the notch filter is shown in Figure 43.

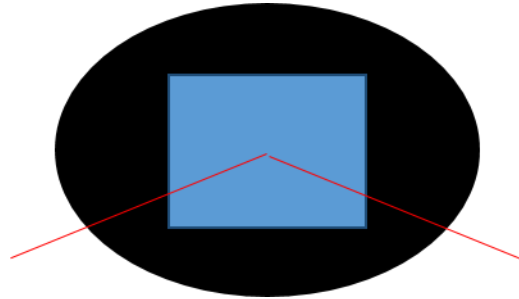

Figure 43: Example of a Notch Filter

Each notch filter bends the laser between  $11.5^\circ$  and  $12.1^\circ$ . After the signal has passed through all three notch filters, it has been bent by a total of approximately  $35.7^\circ$ .

#### 5.4.9 Design Summary

The overall design of the spectrometer, with all parts included, is shown in Figure 44.

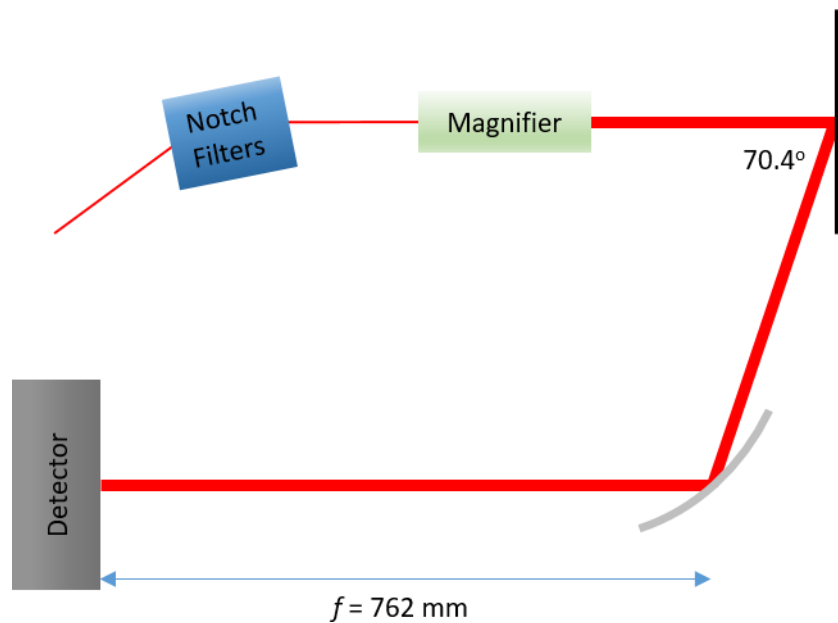

Figure 44: Overall Spectrometer Design

The final specifications of the spectrometer are as follows:

- Laser line  $\lambda = 785$  nm is filtered out
- Spectral Range is  $\pm 225.23$   $\text{cm}^{-1}$  (28.26 nm centered at 785)
- Resolution is limited by the grating at  $1.05$   $\text{cm}^{-1}$  (0.065 nm)

These results satisfy the project specifications listed in Section 2.3.3.

## 5.5 The Microcontroller

### 5.5.1 Microcontroller Theory

For our system, the microcontroller is arguably one of the most important aspects of the project. Without this piece of hardware there would be very few ways of manipulating multiple aspects of a system within a single source. With all this being said, understanding a microcontroller and how they are used is something that is crucial when picking a microcontroller for a system that is being designed. If a user does not know or understand the microcontroller, then actually putting it to use could be troublesome.

There are building blocks that are general for almost all microcontrollers used, regardless of the manufacture which are the following:

Most microcontrollers have a processor that is the “brain” of the microcontroller. This means that for microcontrollers there is a computer processor built into the microcontroller that does all the computation and execution that are inputted from the user in the source code for the microcontroller.

The second aspect of a microcontroller is the memory of a microcontroller, usually tailored to what the manufacture puts on it. For the most part there are 3 types of memory that are usually inside a microcontroller. They are SRAM, FLASH, and EEPROM memory. SRAM is the most common type of memory because it is used to store data that is read and written constantly. It is for the data that is volatile. This means that this is data that is eventually lost when the memory is no longer powered. This can occur when power to the device is no longer being supplied to it. SRAM is used to temporally hold data for running tasks or programs or applications. In the microcontrollers case, it is primarily used for running the different functions or code to allow action to occur. FLASH memory is different than SRAM because FLASH memory is the memory that is stores data that doesn't change. This is usually program memory that needs to state permanent which is considered non-volatile memory. An example of this would be the BIOS of a computer. Finally, the last type of memory is EEPROM which is electrically derisible programmable read only memory. This type of memory is similar to FLASH but the difference is that data is written or erased by one byte at a time which is different from FLASH because FLASH is written or erased by blocks. Because of this flash memory compared to EEPROM is faster, but EEPROM can be beneficial to smaller and older devices because al bytes can be accessed individually for strict configuration.

Another major building block is usually defined what the manufacture decides to put in. Most of the time a couple of Analog to Digital converters are in the microcontroller. These are used to take analog signals (like a voltage) and convert that



analog signal to digital that is used as 1 or 0 for the microcontroller to be able to use as machine language. The opposite is also used in a microcontroller which is an Analog to Digital converter which takes a digital signal (like a 1 or 0) and translates that signal to an analog value. Timers are also used in microcontrollers which can be used for pulse generation or other forms of timing manipulation like the use of a clock or frequency measuring, modulation or more for a connected device. A microcontroller would also be nothing without the ability to manipulate input or output devices. Because of this input and output ports are used for interfaces which allow controlling devices to be used for a certain application. This could be something like controlling an LED, or controlling a motor, or taking values from a sensor. Without this, a microcontrollers use would be very minimal. Because devices are being controlled, a form of communication must be present to allow devices to talk to the microcontroller. One method of this is the serial ports which is a peripheral interface that is used for communication to a computer or a device.

Finally, the last major building block of a microcontroller is the software that is packaged and use to allow the user to create content for device manipulation so that the microcontroller can be used for a defined task. This software can be different for most microcontrollers, but the language the microcontroller uses can vary from microcontroller to microcontroller. Most MCU's will use either the C language, C++, language, Assembly language, or even JAVA language depending on the MCU. Without all these features, a microcontroller would not be what they are today.

Microcontrollers are can also be classified into the different types in relation to their components. Each classification is as follows: bits, memory, instruction set, memory architecture. For bits, there are 8 bit, 16 bit, and 32 bit. Most of the time, 8-bit microcontrollers are used for logic operations, but also arithmetic operations. 16-bit microcontrollers are the same as 8-bit microcontrollers but have a greater performance because they can use more bits, and also they are more accurate because you can precise with the number of bits used in storage. Finally, 32-bit microcontrollers have the most performance, and accuracy but cost more. These are typically used in bigger applications like controlling machines like air handlers or in bigger applications because they are used for higher logic and arithmetic computation functions.

Another microcontroller classification is actually the memory itself. Microcontrollers can also be defined by the memory that they have. There are 2 types of MCU memory classifications. MCU's that use external memory, but also MCU's that use embedded memory. External memory microcontrollers do not have memory that is used to store program memory on the actual chip. There are some microcontrollers that actually use external memory because they rather use external memory that is greater than what could be on the chip. Embedded memory microcontrollers are a microcontroller class that has the memory built into the chip, but also other functions built into it. This means that the chip can have stored in it both program memory, but also data memory, counters, timers, i/o and other functions within the which is why it is referred to as an embedded memory microcontroller.

Instruction set is also a characteristic of microcontrollers. For the most part there are only 2 types of instruction sets. There is CISC and RISC. CISC microcontrollers use complex instruction set. This means that it allows a single instruction for multiple simple instruction while a RISC instruction set uses simple instruction sets. Both have their tradeoffs though. For example, RISC may reduce operation time because it shortens the

operation cycle time while CISC may have a smaller code size because it has less lines in the code.

Finally, actual architecture of a microcontroller can help classify a microcontroller. There are two types of architectures which are Harvard Architecture and Princeton Architecture. The Princeton architecture (figure 45) advantages is that its simple design is easy because it only has single memory access and that the RAM can be used for data storage, but also program storage which allows huge flexibility of software development. Harvard architecture (figure 46) was designed specifically for separating memory banks to operate program storage and other features that are separated from the program storage. In the past, Princeton was perceived as being the overall winner compared to Harvard, but it wasn't until the late 1970's when Harvard started to be recognized as more of an actual contender because of its design advantage features. Harvard's advantage is that it is quicker because it executes instructions of code in fewer cycles which allows parallelism for fetching instructions to be done during the execution of a current instruction so there are no dead cycle times. Overall both have their advantages and disadvantages, and today both are used in different types of microcontrollers.

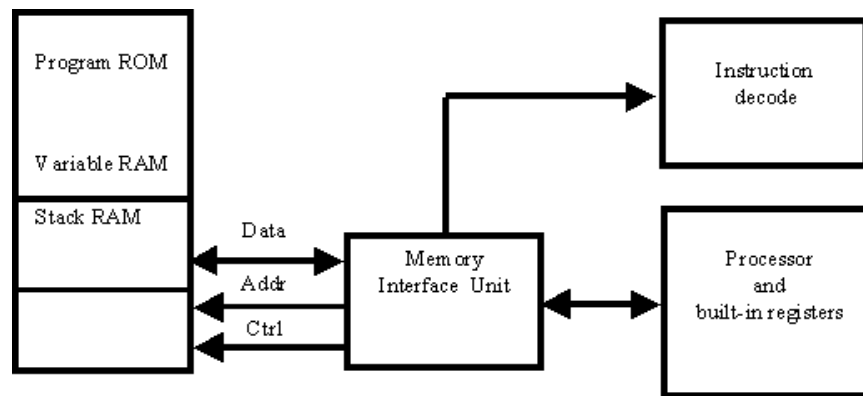

Figure 45: Princeton Memory Architecture (Programming & Customize the 8501 Microcontroller by Myke Predko)

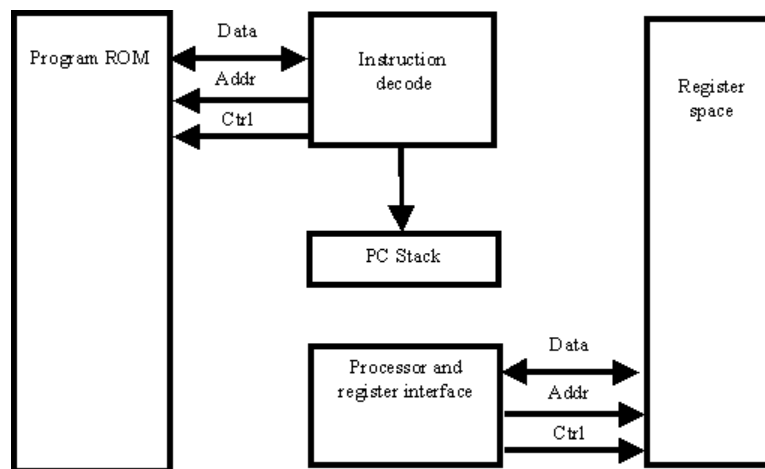

Figure 46: Harvard Memory Architecture (Programming & Customizing the 8501 Microcontroller by Myke Predko)

Today, there are many types of microcontrollers. Here are some of the most common microcontrollers which is the following: 8501, PIC, AVR, and ARM.

8501 Microcontroller was originally invented by Intel and is known as one of the most universally employed microcontroller set which include 3 types of memory sets that are NV-RAM, UV-EPROM, and FLASH. These microcontrollers usually have 3 times and are 256 bytes of RAM. It is an 8-bit architecture that has 40 dual inline package pins with 4kb ROM. It also has four 8-bit ports that can be programmable. One features is that it also has an oscillator with a 12MHZ frequency. The communication protocol that is used is serial with 2 port pins for input and output. Finally, it has timers, interrupters and general purpose registers, special function registers, and special purpose registers that are programmable.

The PIC microcontroller is a microcontroller that is peripheral interfaced. It is a micro-chip technology that is used in appliance architecture. These microcontrollers are used more for hobbyists and people who are in the industry for specific applications. One great aspect of the PIC microcontrollers is that they are widely used and are widely accessible. They are also low cost which is good for people starting out with microcontrollers or for projects that need to be low cost. Usually PIC microcontrollers also have a large fan base because of their low cost and there support which also many program capabilities.

PIC microcontrollers are usually categorized into 3 different types: Base line, Midrange, and High performance. Baseline usually have 12-bit program architecture with a range from six to twenty-eight pin packages. These pin packages can vary, but for the most part this is the range. They are also fairly low cost and good for projects that are for gadgets with battery enabled components. Mid-range is a little different in that it has a 14-bit program architecture. It also has a bigger set of pin package which range from eight to 64 pins. These pins have a huge array of peripheral connections and can be used for both analog, and digital peripherals. Usually they also come with a huge array of communications like I2C, UART, SPI, USB, and other loaded devices like A/D converters, timers, LCD display, etc. Finally, High performance is usually the top of the line for PIC microcontrollers. They have a huge pin package alternative which range from 18 pins all the way to 100 pins. They include everything that both baseline and midrange have, but also have other integrated architectures in them. Usually these architectures are RISC but also have levels of memory like FLASH on them, and also have interrupts and other levels of function.

Advanced Virtual RISC (AVR) microcontrollers is another type of microcontroller that uses the Harvard memory architecture. They typically are 8-bit and are used typically for applications where memory takes a higher precedence. Because of its memory architecture, they are can be used for storing programs compared to programmable memory microcontrollers that use EPROM, or other forms of ROM. One benefit of the AVR microcontroller is the fact that the SRAM, FLASH, and the EEPROM are all built on a single chip. This is great because it eliminates the requirements for other external memory to be used. This allows the device to have everything integrated on it.

ARM microcontrollers are used a lot in today's world. For example, the Arduino UNO is based on the ARM architecture. These typically are 32-bit RISC architecture and are used highly in a lot of mobile electronics. One of the benefits is that they are used for applications where less power is critical. They mainly have max single cycle functioning

with constant 16 and 32-bit register files and a Load or store architecture. They also have a preset instruction width of 32 bits so as to simplify pipe-lining and decoding, but also to minimize code density. One problem could be that there is no support for misaligned memory access. Microcontrollers are used so much in today's society. They are mostly used in embedded applications which is different compared to micro processing like today's computers. Microcontrollers are used in many practices today especially in applications that need devices to be automated and controlled. They are used in remote control applications, office machines, control engine systems, power tools and even toys. Because of this, microcontrollers typically can be cheap and are easy to market because of their use to create more devices that are digital and easy to control. In today's world, you can see microcontrollers used in controlling devices, detaching lighting and control, analyzing temperatures and fire safety/detection, process controlling devices, and even in industrial uses like HVAC. Microcontrollers can also be used for metering other devices. For example, microcontrollers, can be used for a volt meter or analyzing objects that move.

### 5.5.2 Microcontroller Comparisons and Specifications

#### 5.5.2.1 *Texas Instruments and the "MSP430"*

The MSP430 from Texas Instruments was one of the options that was discussed when deciding on what microcontroller to use for the project. UCF has taught the MSP430FG4618 configuration with the JTAG interface. UCF went into great detail in their labs teach multiple techniques for both C and assembly language. Time is of the essence here so using this system before learning a whole new system was a definitely a factor to considered. This is used in the embedded systems to code for every lab. This was one of the main arguments for consideration of this board in the senior design project. This board uses code composer with a USB serial interface (RS232C) to communicate with the computer. This board is very user friendly. The JTAG interface uses C programmer to script for all higher-level coding and a debugging interface to help solve for code errors. Generally, the MSP430 is considered a low-power microcontroller that is based on the RISC architecture. Key features of the MSP430 is that it includes mix signal processing which allows the use of built in analog to digital converters for converting peripheral signals for use of different features built on to the board. Some of these features include low-powered embedded RF and even features for security like different encryption levels. One of the key benefits of the MSP430 is that it offers the user different power options in relation to performance. The following is information provided from ti.com regarding MSP430 and their power options:

**Table 10: Power Options.**

<b>Ultra-Low Power</b>	<b>Low-power and Performance</b>
Lowest standby power - mostly-off applications running below 25 MHz	Advanced computing - up to 48MHz and lowest active power
Lowest power data acquisition - ADC and internal window comparator for reduced CPU wakeup time	High performance sensing - 1MSPS ADC and fast processing through serial communications interfaces
Design flexibility - broadest 16-bit portfolio, now including unified FRAM technology	Design headroom - up to 512 KB Flash memory and 64 KB RAM for advanced algorithms, image processing and connectivity stack support
System on chip options – integrated power management, analog front ends, LCD peripherals, and security features	Minimize discrete components – integrated power management, analog, USB interface, LCD peripherals and security features

Another key feature of the MSP430 is that it offers platforms for wireless communication. Some of the microcontrollers that use Sub-1GHz and Near-Field communication are great for power efficiently and are small with great advantages for RF networking applications.

The MSP430 also has many peripheral configurations. There are many different options for MSP430s, but most of them offer high-performance peripherals which include not only USB, RF and LCD controlling, but also others like different types of analog to digital converters, timers, resets, and other special technologies like capacitive touch.

The MSP430 offers many device configurations as well. These include flash memory that can go up to 512 KB, RAM that can be configured up to 64KB, a huge array of pin configurations that range from 8 to 113 pins with over 25 different pin packages, and finally all of which are fairly low cost depending on the configuration. Configurations can vary depending on the needs and the type of MSP430 that the user is looking at.

Above is the MSP430FG4618 that was considered for the project. As you can see from above, this MSP430 offers an array of peripherals, functions, communications, and controlling options. The picture above shows the memory that is used. It uses RAM that is 4KB-8KB, FLASH and ROM that can be either 92KB – 120KB. The processor uses are 8MHZ which 16 registers. It also has a JTAG interface which is used for communications. Another great part about the MSP430 is that it has 12-bit ADC and DAC channels with 3 operational amplifiers and even a comparator. It also has interrupt ports with 2x8 input/output pins, 4x8 input/output pins, and 4x8, 2x16 input/output pins depending on the configuration. This MSP430 even includes 3 timers, and an LCD display with many communication protocols like UART, I2C, and SPI. Overall this MSP430 is great but could be a bit much depending on the application it is being used for.

**Table 11: Arduino and “The Uno”**

	MSP430	Arduino Uno
Input Voltage Min: Max	1.8:3.6	7-12 V
Digital I/O Pins	80	14 (6 provide PWM output)
Flash Memory	116 KB	32 KB
Clock Speed	8Mhz	16Mhz
Hardware Serial Ports	USB UART	Clock Speed

Arduino is the last option that was discussed for our project, but it was the one that ended up being chosen because compared to Texas instruments, it is a completely opened source platform that can be used for many different projects. The Arduino consists of 2 major parts. One part is the programmable circuit board which is categorized as the hardware of the microcontroller. The other aspect of Arduino is the software or Integrated development environment that is used to control the Arduino board. One great aspect of Arduino boards is that they are able to read inputs like maybe lights on a sensor, for a finger push on a button, or even messages from a computer. They can also turn all input into an output like starting a motor or turning an LED on or off depending on its input like pushing a button, or even taking an input and pushing it onto the internet. The Arduino, like other microcontrollers, is commanded based where the user defines instructions in the software which allows the microcontroller to react and do the instructions sent from the board. This is based on an open sourced programming framework called “Wiring” and also the Arduino IDE which is based off “Processing” which is a flexible software sketchbook that is used for coding.

Compared to the MSP430, one of the great things about Arduino is that it is simple and has an easy to use user experience. Because of this, it allows the user who may not have much microcontroller experience to actually pick up the device and begin creating projects specifically for beginners. Even though it is great for beginners, it also can be used for those who have more experience and are able to tap into the many functions that are built into the board. Because Arduino is open sourced compared to MSP430, Arduino has been used for so many different applications. Here is a quote from the Arduino website, From the Arduino website under the introduction section states that “Teachers and students use it to build low cost scientific instruments, to prove chemistry and physics principles, or to get started with programming and robotics. Designers and architects build interactive prototypes, musicians and artists use it for installations and to experiment with new musical instruments. Makers, of course, use it to build many of the projects exhibited at the Maker Faire, for example. Arduino is a key tool to learn new things. Anyone - children, hobbyists, artists, programmers - can start tinkering just following the step by step instructions of a kit, or sharing ideas online with other members of the Arduino community.”

In general, there are many microcontroller platforms available like Parallax Basic Stamp, Netmedia's BX-24, Phidgets, MIT's Handyboard, but Arduino wraps all these up in a package that is easy to use for the user and allows for simple process/understanding for someone who does not need to dive into the finer details of microcontroller processing and understanding. There are many benefits of using an Arduino board. The first benefit is that it is very cheap. The boards are cheap compared to other boards like Texas Instruments MSP430, or a Raspberry PI. The cheapest Arduino board can be assembled in parts and by hand which allows the user options of what to add or not add, and even the most pre-assembled Arduino board is only less than \$50 which is cheap compared to other boards. Another benefit is that the Arduino is completely cross-platform. This means that whether a user is on a Windows PC or a Macintosh, they can still work on the projects as needed. This is great because some microcontrollers are strictly on Windows PC's which can be a limiting factor for those who do not have access to Windows PC's or do not prefer it. Arduino is also simple, and has a clear programming environment which is great for beginners and even those who are much more advanced. It allows beginners to dive right in and become experts, but also allows experts to fully utilize the hardware because of the ease of use on the software side. It allows C, C++ and other programming languages with a vast array of libraries built by other users. It allows others who may have AVR programming to jump to Arduino based coding because it is compatible with both. Finally, the last benefit (which has been previously highlighted) of using Arduino compared to other microcontroller manufactures is the fact that it is open-sourced and still has many hardware features. Compared to other manufactures, the documentation is not open-sourced and is only in respect to the manufacture while Arduino allows designers to make their own versions which can be used for improvements. Because of this, it allows inexperienced users to create breadboard version and even PCB's of the board which can be used for understanding but also for easy of cost. Because of this Arduino was the perfect choice for a project like this one.

### 5.5.3 “The Raspberry Pi”

One option that was discussed was using a full general purpose computer, but also something that did not need to be the full size of most normal standard computers. This was being considered as an option because researching the project lead to the use of using a computer to display a camera or create a system that fully encompasses all elements of a computer without the need to plug into a normal desktop/laptop pc. This lead to the discussion and research of using a “Raspberry Pi.”

The Raspberry Pi is pretty much a general-purpose computer. Compared to a microcontroller, this piece of equipment can run a full operation system, and with the right attachments to the board, can even utilize peripherals that are normally attached to desktop/laptop pcs. One big aspect of the raspberry pi is that it is complicated compared to using an Arduino or even a Texas instruments board. Usually Raspberry Pi's are used for projects there a complicated like building a robot that needs to do many calculations or for projects that require to use many more peripherals then just controlling simple electrical devices. Compared to an Arduino even the architecture is different because it is a general-purpose board. Below shows the memory architecture of a raspberry pi:

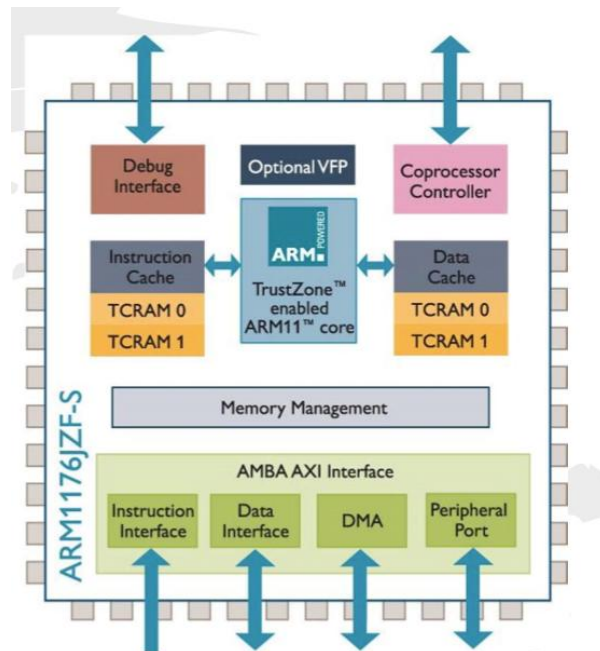

Figure 47: Raspberry Pi RISC Architecture (permission pending from ARM)

This architecture though is RISC is different than microcontrollers because it built like a general-purpose computer which means peripherals, processing, memory management can be different than typical microcontrollers. For example, the Raspberry pi uses an ARM processor that runs at 700 MHZ which is much more compared to the Arduino or the Texas instrument board. It also even has integrated graphics and 512 ram built in board. These are features that are not in in microcontrollers because they are targeted for a different audience and used for different projects. Another take way is that it even had an HDMI, Ethernet port, and audio jacks because compared to a microcontroller, it is literally a mini computer.

Even though this is a great option to use for this project, there are some drawbacks to using a raspberry pi compared to an Arduino or a Texas instruments board. One huge drawback is the complexity. Compared to microcontrollers, the coding and the hardware manipulation takes a lot longer to learn compared to using other microcontrollers. Because this project needs to be done within a smaller time frame, this because a huge stopping point for using something as sophisticated as the Raspberry Pi. Even doing easy tasks like reading values from a sensor could potentially take longer to do because of how complex this board is. For projects that are not as complex in theory, may not translate well in using a complex board like the Raspberry Pi. Another drawback that was considered was the cost compared to using an Arduino. Arduino boards are cheap because they are strictly microcontrollers. Because of this parts are cheaper for Arduino boards compared to parts that could be needed on a Raspberry Pi. One of the focus of this project is to keep the cost as low as possible because other parts like optical parts tend to be a lot more expensive. This lead to the conclusion that though the Raspberry Pi is an incredible piece of equipment, it could be the wrong choice for the type of project that is being created. For a project that just requires the use of motors manipulation, laser manipulation, and sensor readings, a Raspberry Pi could be an option that is simply “overkill” for the project.



## 5.6 Arduino Specifications, Features, and Schematic

### 5.6.1 Power theory, the external & internal power

The Arduino that was chosen for the project is known as the “Arduino Uno R3.” This is one of more common Arduino microcontrollers. This board compared to the Arduino Mega or even some of the other boards is that it does not use the FTDI USB to serial driver chip. Instead this uses a ATmega16U2 chip which has been programmed as a USB to serial converter. Even though this does not use the FTDI chip, it still uses serial communication via USB conversion.

One feature if the Arduino Uno is that it can be powered via USB or with an external power supply. When an external power supply is connected to the Arduino Uno, the controller has been programmed to use whatever source is more powerful to power the microcontroller. The board allows for external power to be connected either from an AC to DC wall adapter. This means that’s on the board there is a 2.1mm center-positive plug that connects to the board power jack. Because of this, leads can be taken from the Vin and Gnd pin headers of the power connector to a breadboard or other devices. Because it allows an external source to be used, it requires that the AC to DC adapter being plugged into the Arduino must be between 6 – 20 Volts. The drawback of this is that if less than 7volts is being supplied from the external source, it could cause problem with powering the board which could lead to the Arduino board becoming unstable. Another piece of information to consider is that if supply the board with greater than 12 Volts, there is a voltage regulator within the board that could potentially over heat and cause damage to the board. Because of these constraints of using the Arduino Uno, the project peripherals needed to either be supplied with an external power source that was within the range of 7 to 12 volts through the Arduino, or power them externally outside of using the Arduino, and let the Arduino be powered through the USB connection.

### 5.6.2 Specifications, Features, and Schematic

The Arduino Uno has many different features and specifications. Earlier, the external and internal powering of an Arduino and its devices was discussed, but the actual specifications of the power is detailed differently. The board when power is supplied from the USB allows for the board to output 5V. The pins output a regulated 5V from the boards regulator. You can even bypass the voltage from either the 5V source or the 3.3V source, but this is not recommended because it can damage the board. There is a 3.3V board regulator which has a maximum of 50mA current draw. Finally, there are ground pins to ground the board as well as IOREF pins to provide a voltage reference in respect to the microcontroller operation.

Another specification of the Arduino board is the memory that is on the board. The board has an ATmega328 microcontroller chip which has 32KB of memory. Within this 32KB of memory, .5KB is used specifically for the bootloader. Separate from the microcontroller memory, is the built-in SRAM that is at 2KB, but the board also have 1KB of EEPROM. For details of microcontroller memory, see section *5.5.1 Microcontroller Theory*.

Input and output is a key feature of the Arduino Uno. There are 14 pins digital pins and 6 analog pins. Each of the 14 digital pins can be configured as either input or output using functions in the Arduino software library. All these pins can operate at 5volts and each pin can either supply or receive a maximum of 40mA, but the recommended is 20mA. Each pin has an internal pull-up resistor which is disconnected by default that has a resistance of 20-50kOhms. 40mA should not be excited on the board because it could cause damage to the board and its pin headers. The image bellows shows the pin mapping of the Arduino Uno.

Some of the pins also have special functions. For example, Pins 0 and 1 are used for serial communications which allow serial data to be received (pin 0) and transmitted (pin 1). These are used to connected to the USB to TTL serial chip. Pins 2 and 3 are used for external interrupts which can be configured for an interrupt on either a low value that is a rising or falling edge or in a change in value. Pins 3,5,6,9,10, and 11 can be configured for pulse width modulation using 8-bit output and functions in the Arduino library. Pins 10, 11,12, 13 are can be configured for things slave select, master in slave out, master out slave in and the clock which allows these pins to support SPI communication using built in SPI library. There are also is an LED which can be driven by digital pin 13. Finally, Analog pins 4, and 5 support two-wire communications. The analog pins provide 10-bit resolution which can be measured from 0 to 5 volts, but it is also possible to change the upper end of their range using the AREF pin which is used for reference voltage for analog inputs and allows resetting the microcontroller. Below shows the entire Arduino board and its hardware architecture.

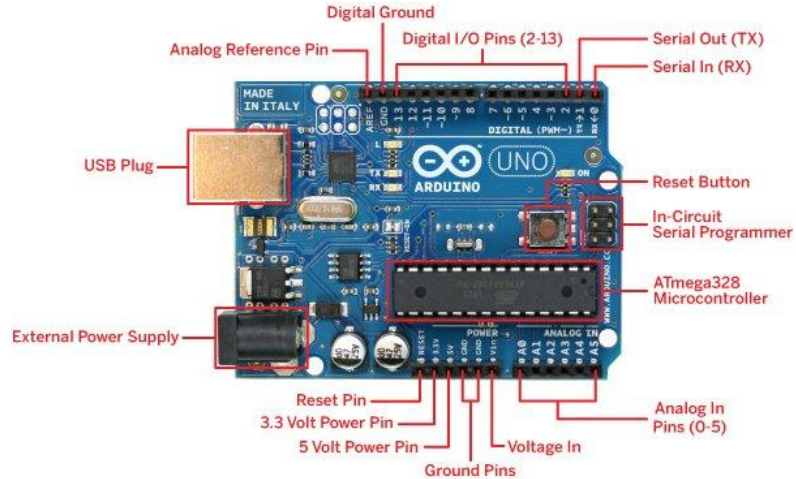

**Figure 48: Arduino Uno Hardware Architecture (permission pending from Adafruit)**

From the above picture, the design outputs are the current design mapping of the components that will be used in the system. This means that for most of the digital pins as well as a couple of the analog pins, devices will be connected to these pins to read values from different equipment. For example, from the image above, pin 2 is designated for the contact switch because this pin specifically can be used to as an interrupt. This is needed because we need the switch to interrupt the system at any moment. This is described more in the section under contact switching. Another example is the temperature fans. These temperature fans are designated toward pins 5 and 6 specifically because of the

pulse width modulation. Now there are other PWM pins, but these were chosen because they output at a higher frequency. This is discussed in the temperature control section in more detail. The temperature sensor pin designation was chosen at random because it does not need any special requirements. This also applies to the backlight that will be used which has been assigned to pin 7. Finally, digital pins 9-11 are all specifically to be used with the spectrum detector integrated circuit. For example, the detector requires a shift gate, an integration gate and the use of the master clock. Because of this digital pins 9 – 11 are used because they are specifically designed for connecting and driving the detector using the clock. These will be discussed in detail in the spectrum detector section, also known as the charge coupling device (CCD).

## 5.7 LASER POWER CONTROL

### 5.7.1 Laser Power Control Theory

Laser power control allows the user of this device to control how much laser power is being used when measuring the Raman spectrum. Generally speaking, when attempting to induce Raman scattering, more laser power results in stronger scattering, which increases the ability of the detector to measure the spectrum. However, there are several reasons why the laser should not always be at 100% power.

In order to prevent the user from receiving any eye damage from the laser, the only way to view the sample is through a camera mounted to the top of the microscope. This camera contains a CCD detector array, which can easily be burned out if too much light enters the camera. The laser and the camera should both be active when positioning the sample. If the laser is too powerful, this could result in the camera being destroyed. Thus, whenever the camera is activated, the power of the laser should be drastically reduced.

Another possible danger comes from the different objectives that can be used with the microscope. When using low magnification objectives, the laser is focused very tightly onto the sample in order to create the Raman scattering. Ordinarily, this does not damage the sample, allowing the analysis to be re-run multiple times, or even letting the sample undergo other types of analysis. However, if a high-powered objective, such as 40x or even 100x, the laser intensity can become so high that it might damage the sample. Thus, the laser power should be lowered when using more powerful objectives.

### 5.7.2 Specifications and Pulse Width Modulation

The laser that the system is using comes with a laser power control module that has the ability to be controlled via Molex connectors that connect to breadboards and other pin driven devices. This means that the laser system can be controlled by turning the laser on and off and as well as allowing for laser modulation to occur. The laser modulation is done by biasing the laser with the voltage for that specific laser power. This was achieved by using pulse width modulation. Pulse width modulation is a technique that is used within the Arduino which allows for extrapolating analog results with digital means. This means that we have a 5v source that the Arduino can supply. Because of this we can take the 5v source and use pulse width modulation to output a lower signal that is needed for a device instead of just output 0v or 5v. This is done by the use of digital values. The break of what is done is that the Arduino allows for digital control to create a square wave. This square wave is used to switch a signal between on

and off. This allows a switch between supplying 5v and 0v or “turning on” and “turning off.” The voltage output is done by changing the portion of time the output is 5v versus the portion of time when the supply is 0v. This actual duration of time is known as the pulse width. This pulse width can be modulated which allows the Arduino to output an analog voltage signal that can be varied from 0 to 5v. This process can be used repeatedly to a low something to be continuously powered. For example, if PWM is used on an LED we can control its brightness by continuously using the PWM signal as long as it is the required voltage to turn on the LED which affects the brightness of the LED. In our case we are using PWM to control the output power of the laser. The figure below shows pulse width modulation in relation to the duty cycle.

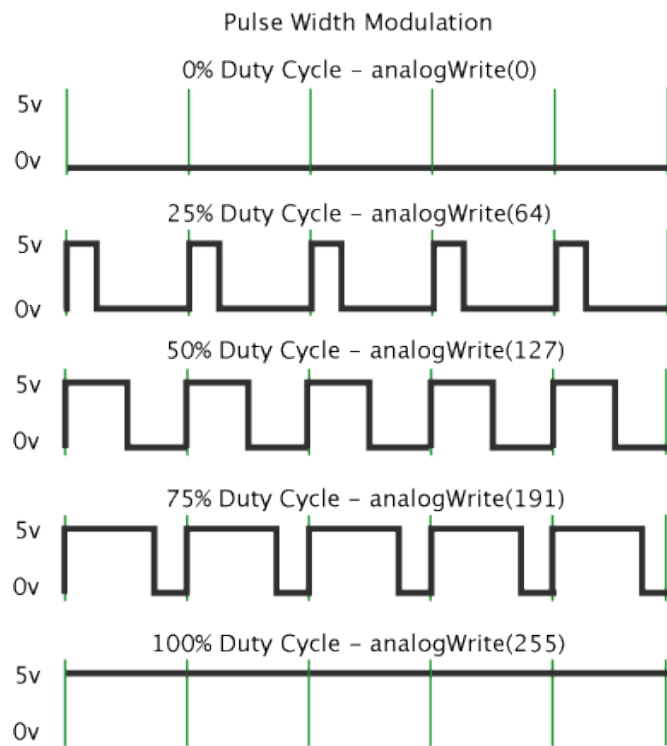

**Figure 49: Pulse Width Modulation using an Arduino Uno (permission pending from Arduino.cc)**

The duty cycle is the cycle of time used to dictate the actual analog output of the Arduino. In our case, the duty cycle is kind of the multiplier of percentage of how much output power in respect to the duty cycle. For example, if the duty cycle is set to 50% then the output would be modulating at an analog output voltage of 2.5V which is half of 5V. The top graph of the figure shows pulse for a given time period between 0 to 5V. Most of the PWM pins run at 500Hz, but pins 5 and 6 run at 980Hz. So for example, if the pin is set to 500Hz, the green lines above would be 2 milliseconds apart. In code to actually get a pulse width modulation, the function `analogWrite()` would be used to actually change the duty cycle of the analog output pin of the Arduino Uno. So if we wanted to have full power or 100% duty cycle, then we would use `AnalogWrite(255)`. The `analogWrite()` uses a range of 0 – 255 where 128 is 50% duty cycle which is 2.5V and 255 is 100% duty cycle or 5V. The pins that actually use PWM are 3,5,6,9,10, and 11, but only pins 5 and 6 run at 980Hz. The figure above shows this relationship.

Now this will not be exactly 2.5V, but you can use filters to actually smooth out the PWM signal being generated from the Arduino Uno pin. One way to do this is to create a RC filter. This filter depending on the components used can allow a smooth signal similar to a dc voltage, but other aspects of the signal will be affected like the settling time or the response time. This is discussed in detail in the temperature control section.

The Table below shows the relationship between laser power and the relationship between the duty cycle and the values used for pulse width modulation.

Duty Cycle	PWM Value	Output Voltage
0	0	4.1 mV
.4%	1	23.4 mV
.8 %	2	42.7 mV
1.2 %	3	62.0 mV
1.6 %	4	81.3 mV
2 %	5	100.6 mV
2.4 %	6	119.9 mV
2.8 %	7	139.2 mV
3.2 %	8	158.5 mV
3.5 %	9	177.9 mV
4%	10	197.2 mV
10 %	26	500 mV
20 %	51	.998 V
30 %	77	1.495 V
40 %	102	1.998 V
50 %	128	2.498 V
60 %	153	2.97 V
70 %	179	3.48 V
80 %	204	3.97 V
90 %	230	4.48 V
100 %	255	4.98 V

**Table 12: Laser Power Bias Table for Laser Power Control**

### 5.7.3 Circuit Analysis

#### 5.7.3.1 Power Control Utilization & Parts

Power control specifically is done through the external module that is located prior to the laser. This module is a high power spectrum stabilized laser module that allows full power control directly or via pins. This laser offers a high power single mode output that is about 100mW with a bandwidth that is close to 1 MHz The max load this laser can draw is 200A and a 2.2 max voltage drive which the laser module requires 5V DC to be powered and the maximum power consumption is only 5W which is small compared to other devices within the system. This power can have 5V DC either from a wall outlet or with pin control, but the 5V DC from the wall uses a toggle switch while pins is controlled different. This module also offers using an internal photodiode that can be used in a circuit to identity the power of the laser. Figure 50 below shows the module side were a Molex connection can be connected. Figure 51 below shows the module that

is ran from the laser to the module which is how laser power control can be connected to a breadboard or PCB as needed.



Figure 50: Molex Connection for connecting wires for remote operation



Figure 51: Laser Power Module

In order to actually connect the module to the breadboard, a 10-pin Molex connector must be used to allow connection from the breadboard/pcb to the module. This is done by ordering the specified part in the module datasheet. This part is only Molex mating connector to the module. Crimp terminals are then needed to connect wires to the Molex connector which then allows for wires to connect from the module to the breadboard. The figure below shows the Molex connector and the crimped terminals connected to wires to create a Molex wire connection.



**Figure 52: Molex wire connection**

To actually control laser power, requires a procedure detailed in the datasheet. The following is a step by step tutorial to do remote operation of the laser. This remote operation allows for laser power modulation as well as turning on the laser on and off. Another connection of the laser module is the use of the photodiode which is discussed in the laser photodiode section from previous section. The remote operation steps are as follows:

#### Laser start up:

1. Mount Laser module onto a suitable heat sink using corner mounting holes.
2. Assure that external laser enable switch on sidewall of laser is on Off (O) position.
3. Plug pre-wired 10 pin Molex connector into module sidewall.
4. Assure that external 5v DC power to the module is off (pin 6) and the Laser enable (pin 7) is tied to ground.
5. Toggle external laser enable switch mounted on sidewall of module to the ON (I) position.
6. Apply power (5V DC) to pin 6.
7. Break connection to ground on Pin 7.

#### Laser Shutdown:

1. Tie pin 7 (Enable) to ground.
2. Turn off 5V power supply to pin 6.

From the list above in order to allow connecting and breaking of ground as switch will be used on Pin 7 which is the enable of the laser which is required to be broken and grounded in order to start up and shutdown the laser. Pin 6 will be connected to the 5V power supply which is connected via a 5V DC wall out which is ran to the PCB/breadboard. The figure below shows the schematic of setting up the laser module for turning on and off the laser.

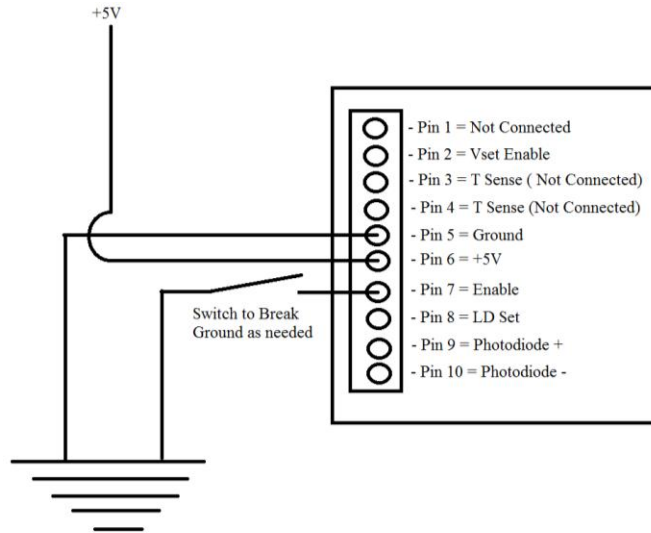

**Figure 53: Schematic for the Laser Module**

In order to utilize remote operation for laser modulation, a different schematic is needed to achieve this. In order for this to occur, pin 2 which is the Vset Enable pin on the laser module must be tied to ground and pin 8 which is the LD set needs to be biased from 0 to .2V to adjust the laser output power from 0 to max. In breadboard testing, biasing from 0 to .2V lead to only being able to control 4% of the laser output. In further testing, we found that biasing up to 5V allowed for max output to occur. This could be because of the schematic that was used to allow for PWM control from the Arduino which could be affecting how the bias is occurring, but regardless this is a comparison from theory to actual real life testing. The figure below shows the schematic for utilizing remote operation for adjusting the laser output from 0 to max. Figure 54 shows these 2 schematics built on a breadboard for testing and pcb designing.

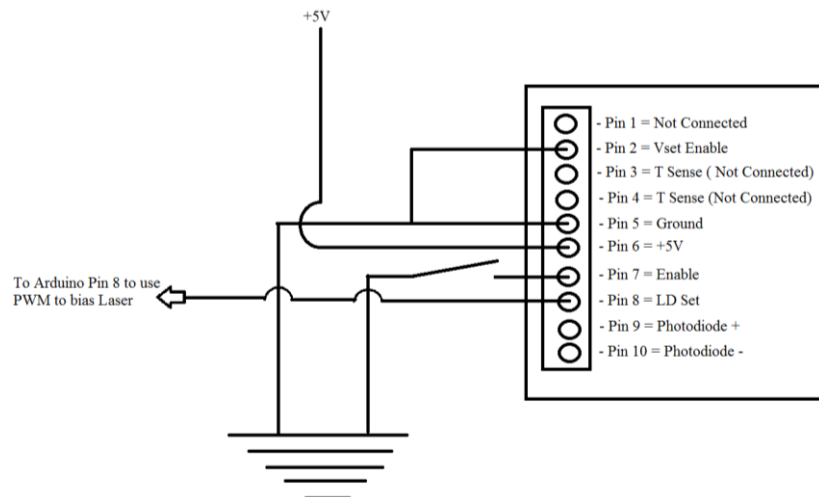

**Figure 54: Schematic for laser output power**



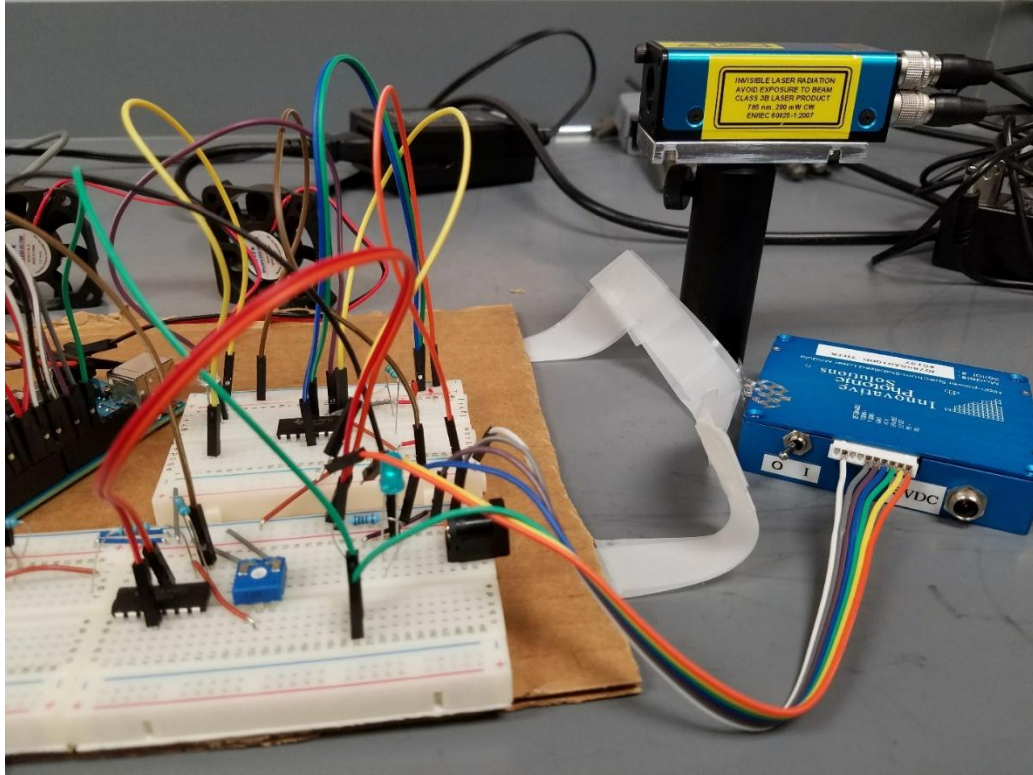

**Figure 55: Breadboard for laser start up, shutdown, and laser modulation**

In order to actually verify that the laser power is actually correct and modulating as needed. A special tool was used to test and calibrate the power. This tool is a product called a LazerCheck which is a handheld power meter created by a company called Coherent. This device allows for taking quick power readings from a laser. This device has an integrated sensor that is used to read the laser power of the input laser beam. It also has auto-ranging with peak sample and hold to adjust to the input laser. The power measurements that the LazerCheck can read is from 10 uW to 10 mW for auto ranging but for general lasers with higher power, it can read up to 1 W of power using the built in attenuator. This, for our system works well because the max output of the laser according to the spec sheet is about 100mW. This tool also can be used for lasers that are 400 to 1064 nm wavelengths which meets our laser requirements of 785 nm compatibility. This tool was used to calibrate the laser output and verify that all modulating output is actually reflecting the correct values when laser modulation is in use. The figure below shows the LazerCheck used in the project to compare laser power modulation with respect to the biasing voltage into the laser module.



Figure 56: LaserCheck handheld

## 5.8 TEMPERATURES SENSING & CONTROL

### 5.8.1 Temperatures Sensing & Control Specifications & Purpose

Temperature is variable that can be very crucial to the development of a system. Temperature affects every aspect of your system. For example, if a motor gets too hot, it can burn out and cause a fire, if a microcontroller gets too hot it can shut off, or burn up, and not only could potentially cause a fire, but also destroy your entire system. Even in small microelectronics, temperature plays a huge part in the overall system. If a transistor gets too hot it can burn out and if this transistor was designed as a switch for maybe a safety system, then the safety system no longer works. Making sure your system in terms of microelectronics, but also in the overall system is completely cool and not over heating is a must. Heat is one of the biggest concerns in developing a system. Most systems have some form of heat transfer that is used to take hot air from the system. Most sections within the design have some form of heat transfer or cooling in the system. The figure below shows the laser being used and the heatsink attached to the laser. This laser is a metal plate that attaches to the bottom of the laser. It is used to absorb excessive heat from the laser so that it does not get too hot.

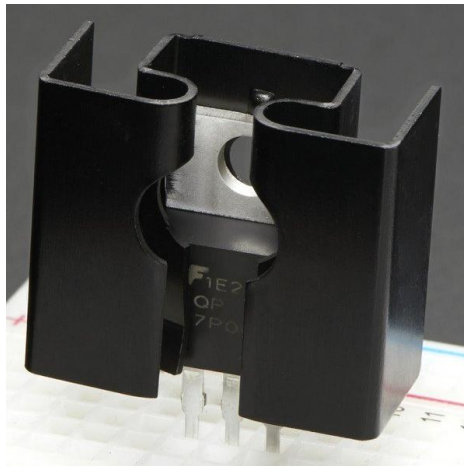

Figure 57: Laser Heatsink

### Laser Heatsink

Other devices within the system also require a heatsink or some sort of way of cooling. For example, one of the transistors used in the circuit that is discussed in 5.8.4 *Circuit Analysis & Schematic* can need a heatsink because it is a transistor that is known to get hot depending on the application and how the transistor is being used. In this

system when breadboard testing occurred, for the most part the transistor did not get too hot, but a heatsink was still used on the transistor because this is a system that in general could be on for long periods of time. Because of that, a design decision was made to include a heatsink regardless of how cool it is because it is better to have the heatsink than to not have it at all. This transistor that is being used in the circuit is called a TIP120. Its characteristics and specifications are discussed more in section 5.8.4, but in this situation the biggest take of is to know that it can potentially run hot and can run better having a heatsink installed on the top. The figure below shows the transistor being used and the heatsink on top. This heatsink is used because it fits the transistor package. The TIP120 comes with a TO-220 package. Therefore, the heatsink that is used is a TO-220 package on the TIP120 NPN Darlington transistor.

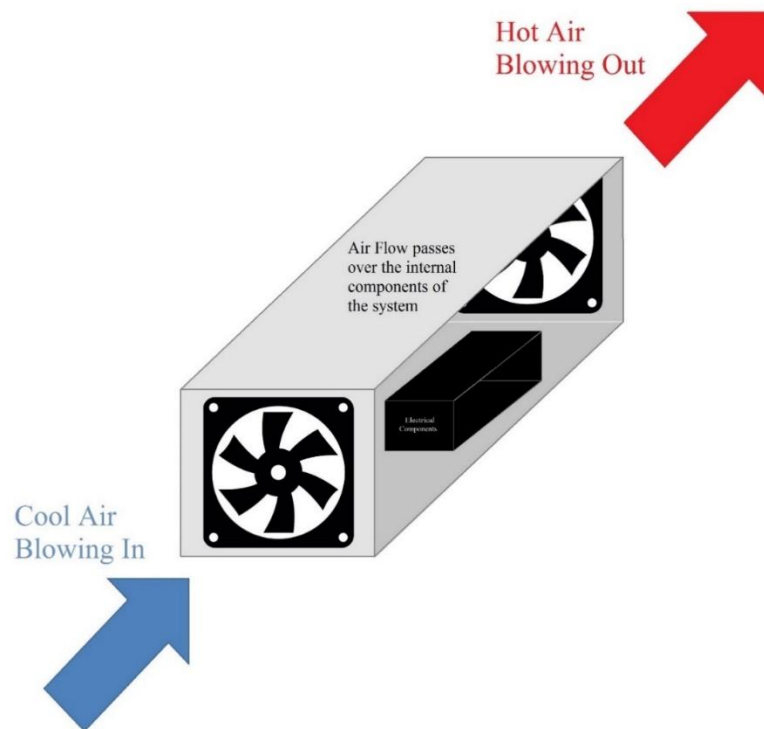

**Figure 58: TIP 120 Darlington Transistor with a TO-220 package heatsink**

Finally, the last major section that will have some form of heat regulation is the internal box itself where a temperature sensor and 2 fans will be placed. A lot of electronics, but also a lot of optical components will all be within a closed box. This box most likely will generate some heat, and because of this 2 fans will be placed where maximum air flow can be achieved. The temperatures main use will be to read the temperature of the box. The temperature sensor that will be used in the enclosed system is discussed further in section 5.8.2.1 and 5.8.2.2. The main take away of this is that 2 fans will be used to regulate the air flow within the system. 1 fan will be used as an intake fan which will cold air to be blow into the system while the other fan will be used to blow hot air being generated from components within the closed internal box system. From there, the air will blow in to the box and over components that need cooler air to function compared to other devices that have higher temperature thresholds. Overall the desired temperature of the box is to keep the box at room temperature regardless of what components are being used within the internal closed system. This ensure that components that are placed in the box can be at optimal working conditions because they are being regulated in an environment that is mimicking room temperature. Some optical components and the data that is being read can be affected by temperature. Because of this, it is not only crucial to keep the laser at room temperature, but also all the internal components of the closed system. This is why the 2 fans are going to be used to constantly keep the internal components at room temperature. There are other options to

regulate temperature and air flow which are discussed in *5.8.3.1 Fan Specifications and other options*. The figure below shows simple diagram of how general air flow is going to be achieved.

The diagram below does not represent the actual closed system, but just shows how general air flow is desired in the closed system. This diagram is basic and just gives the reader a general idea on how air flow works. Regardless of the air being pushed in, hot air will still generate because of the components. With testing that will occur once the box and the components are installed, if the components are getting hot or the temperature of the box is rising then vents or side heatsinks will be needed. For the time being, most of the components stayed cool in breadboard and basic design testing so for the time being fans will be the only source of air flow. Overall, with this design, the system should stay cool regardless of the load. The system will be placed in a cool environment with a defined room temperature and not by other devices that generate too much heat.



**Figure 59: General Air flow of the closed box system**

## 5.8.2 Temperature Sensors

### 5.8.2.1 Analog vs. Digital temperature sensors

One of the aspects of the system was to find a way to know the ambient temperature of the box in real time. This is needed in order to know whether the overall temperature of the box is high which can indicate that components within the box are getting too hot or are operating in a temperature outside of normal operating temperatures which was defined as room temperature. This led to finding an appropriate temperature sensor. For Arduino the 2 types of temperature sensors that have been established are analog and digital temperature sensors.

Analog temperature sensors have been around for many years. They quite possible are the most used temperature sensors because they give fairly accurate readings. One of the great things about this particular temperature sensor is that it has a wide range, but still is considered a low power temperature sensor. This is great for systems that are on for long periods of time but still need constant data sent to the microcontroller. This temperature sensor gives analog voltage that is proportional to the ambient temperature in the enclosed environment that it is in. Connections for this temperature sensor are described in the figures below.

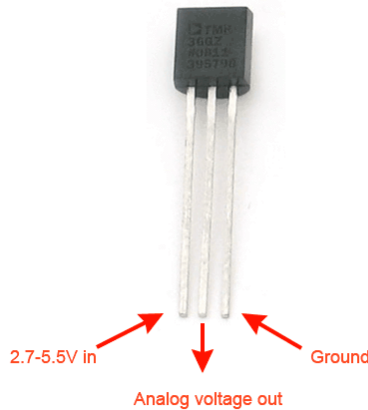

**Figure 60: TMP36 Analog Temperature Sensor**

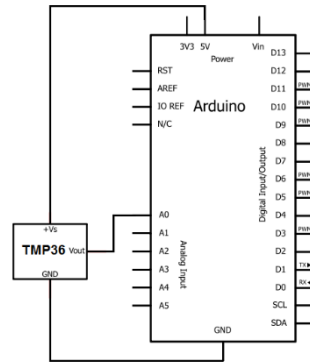

**Figure 61: TMP36 Circuit**

For this temperature sensor a voltage between 2.7-5.5 volts must be supplied to the temperature sensor, where the second pin will run into the analog output pin of the Arduino, and finally the 3<sup>rd</sup> pin will be ground the temperature sensor. The current draw is only .05mA which is great because an Arduino can not only supply enough voltage, but it can also supply enough amps without putting too much load on the Arduino. The range this temperature sensor outputs is at .1v it will be -40°C and output 2V at 150°C. In Fahrenheit this would be -40°F and 302°F. As you can see this is a huge range for the temperature sensors which is great because it can be used in many extreme temperatures. The drawback for this specific temperature sensor is that at 125°C the accuracy of the temperature sensor starts to decrease. To verify that the voltage to temperature output is correct, a formula is used. The formula is  $\text{Temp in C} = 100 * (\text{reading in voltage}) - 50$ . This is the formula that is can be used to take the voltage reading and output the temperature in a terminal or serial terminal. To actually see the range of accuracy and the range of voltage the output will be from the temperature sensor, The figure below shows the output voltage vs temperature. This is used to see that the readings from the temperature sensor match ambient temperature.

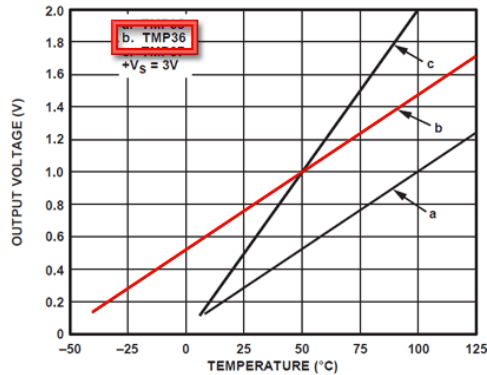

Figure 62: Output Voltage Vs Temperature

As you can see from the figure above, this describes the fairly linear graph relationship between output voltage and temperature. One of the great things about analog temperature sensors is that this is actually fairly accurate.

Digital temperature sensors are similar to analog temperature sensors, but vary in how they are set up in circuits and how they communicate. For example, the digital temperature sensor that will be used in the project is a DS18B20 digital temperature sensor. This temperature sensor operates on a “1-wire” setup with a huge amount of precision. This digital temperature sensor in particular can give up to 12-bits of precision using the Arduino’s onboard digital to analog converter where it is connected to the digital pins on the Arduino Uno. This digital temperature sensor uses a temperature range of -55 to 125°C which in Fahrenheit is -67°F to +257°F. Digital temperature sensors are great because of their precision. For example, this temperature sensor uses 9 to 12-bit resolution for precise data with a single wire of communication and a 64-bit ID that is burned into the temperature sensor. The accuracy is very fine with only a  $\pm 0.5^{\circ}\text{C}$  accuracy. Now this accuracy in particular though is only for a pre-defined range. This range in particular is from  $-10^{\circ}\text{C}$  to  $+85^{\circ}\text{C}$ . Because this temperature is digital, it can be programmed to have a temperature limit alarm system that works well with microcontrollers like Arduino. With a digital temperature sensor, there are queue times for getting data. The query time for this particular sensor is only 750ms which is very small. The operating voltage for it is 3 to 5.5 volts which works well for microcontrollers like Arduino which can supply 5v directly. The figure below shows the digital temperature sensor. Now putting this temperature sensor into a circuit is different than an analog temperature sensor. An analog temperature sensor can be hooked up directly to the Arduino Uno’s pins as long as it has power, but a digital temperature sensor actually requires a resistor to be used as a pullup resistor. This pull up resistor connects from the data pin to the vcc pin. The figure below shows the schematic for using the DS18B20 digital temperature sensor. To actually see how this temperature communicates via code and 1-wire see the software design section.

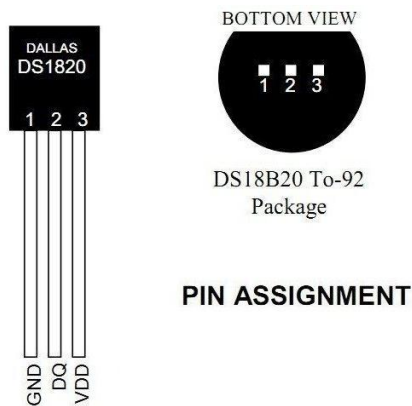

Figure 63: Digital Temperature Sensor DS18B20 Sensor

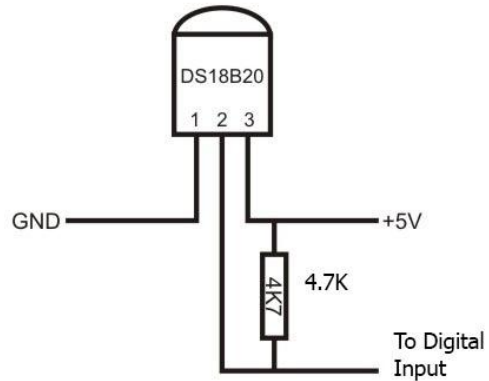

Figure 64: Schematic for the Digital Temperature Sensor

One difference between an analog temperature sensor vs a digital temperature sensor is that instead of having a linear graph that shows a voltage to temperature relationship, a digital temperature sensor on the other hand has a table where every temperature that is read is converted to a digital output that is binary and/or in hex. Regardless its converted into machine understanding. Table shows the relationship between temperature and digital output of the digital temperature sensor.

TEMPERATURE (°C)	DIGITAL OUTPUT (BINARY)	DIGITAL OUTPUT (HEX)
+125	0000 0111 1101 0000	07D0h
+85*	0000 0101 0101 0000	0550h
+25.0625	0000 0001 1001 0001	0191h
+10.125	0000 0000 1010 0010	00A2h
+0.5	0000 0000 0000 1000	0008h
0	0000 0000 0000 0000	0000h
-0.5	1111 1111 1111 1000	FFF8h
-10.125	1111 1111 0101 1110	FF5Eh
-25.0625	1111 1110 0110 1111	FE6Fh
-55	1111 1100 1001 0000	FC90h

\*The power-on reset value of the temperature register is +85°C.

Figure 65: Temperature and Digital Output Relationship

The DS18B20 is very versatile because it can be powered 2 separate ways depending on your use. "Parasite Mode" is when the data line is being powered and this requires only the use of 2-wires instead of using the 3 wires for a normal mode. The parasite mode is when the data wire gest the +5V but the VDD pin does not, but the downside of this is that it limits the number of sensors that can be used and also wire length can also affect the sensors in this mode. Therefore, this mode is limiting and is only good for short distances and a small number of devices. For this project the length of where the temperature sensor may vary on its internal placement therefore this mode is

not suitable for this project. The DS18B20 can also allow multiple sensors hooked up to it. The figure below shows multiple sensors hooked up to a single circuit with easy 1 wire communication via normal power mode. This can also be done for parasite normal mode, but the circuit will vary. The figure below shows the circuit that would be needed using multiple sensors in parasite mode.

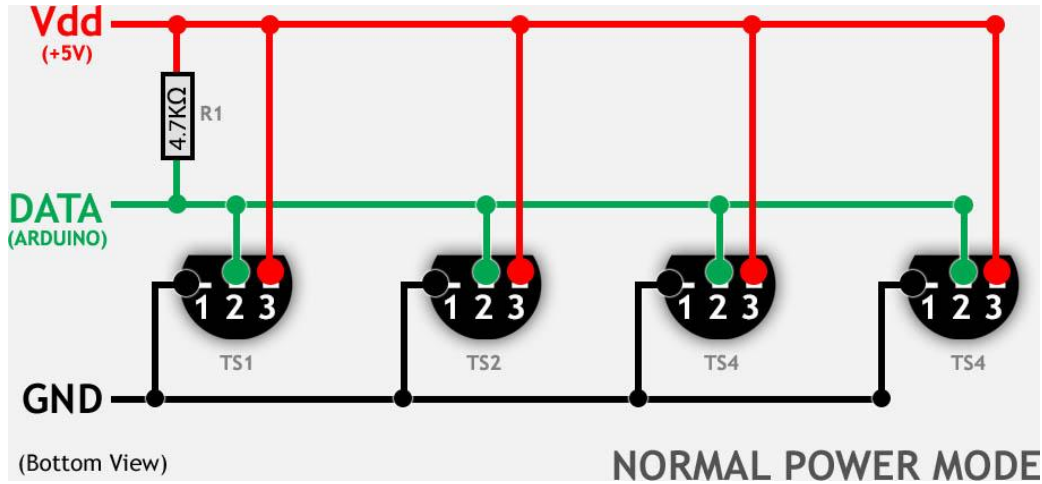

Figure 66: Shows multiple digital temperature sensors in normal power mode (permission requested from Tweaking4all)

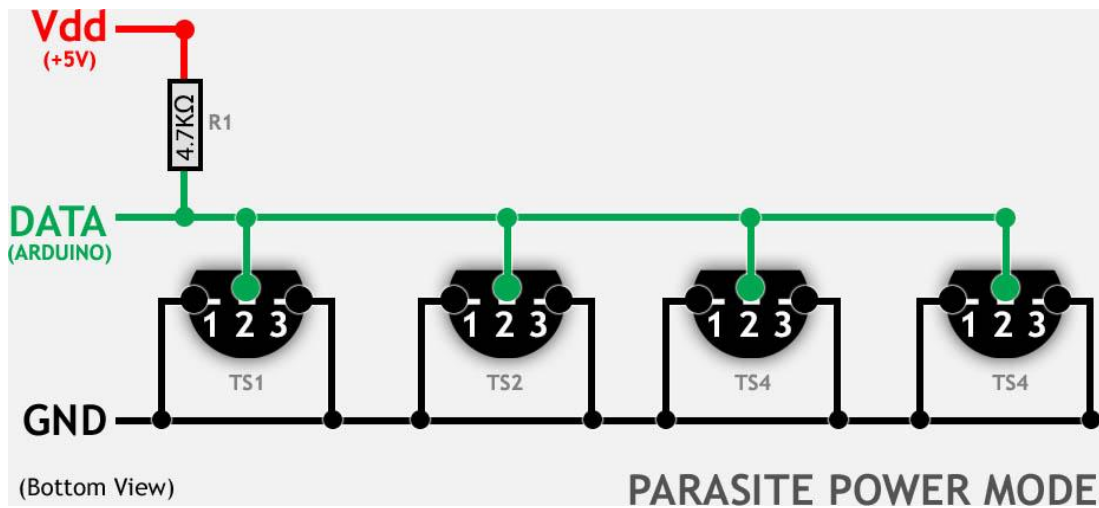

Figure 67: Shows multiple digital temperature sensors in parasite power mode (permission requested from Tweaking4all)

#### 5.8.2.2 Comparison & Justification

Analog vs Digital temperature sensors is a crucial component of any project. Choosing the correct one or not can have different effects depending on your project and your readings. There are different reasons as to why one is to be chosen than the other. Below is a pro's and con's list for both analog and digital temperature sensors.



## **Analog Temperature Sensors**

### Pro's

- Fairly precise with readings
- Easy to wire directly to microcontroller
- Cheaper than Analog temperature sensors
- Easier to code

### Con's

- Not as accurate as Digital temperature sensors
- Harder to wire multiple sensors to a single microcontroller
- Multiple sensors will each take up a single pin on the Arduino which can use up the pins on the Arduino

## **Digital Temperature Sensors**

### Pro's

- More Precise than Analog temperature sensors
- Easier to wire than analog sensors because of the “one-wire” feature.
- Easier to connect multiple sensors, but still get accurate readings from a specific sensor

### Con's

- Coding can be frustrating because it uses bus communications
- Cost more than Analog temperature sensors (usually 2-3 times more)

Because of the results above, the digital temperature sensor DS18B20 was the temperature sensor that will be used in the project. This is because even though coding the digital temperature sensor may be harder, the accuracy of the digital temperature sensor will pay in relation to what speed the fans that will be cooling the system. The fans will be discussed in the next section. Another reason why the digital temperature sensor was chosen over the analog temperature sensor is because it allows for multiple sensors to be attached to a single pin. The Arduino Uno only has a limited number of pins. Therefore, adding multiple analog temperature sensors will take away from the pins being used in the project. Even though the project currently is only using a single digital temperature sensor, having the possibility of allowing multiple sensors to be hooked up to a single pin allows for ease of use and could later be added to the existing circuits. Digital temperature sensors in general are starting to phase out analog temperature sensors because of their easy to use circuits and the “one – wire” setup. Even though coding can potentially be a problem, many Arduino ide libraries have been developed to use the digital temperature sensor because Arduino is open-sourced. Overall it seems that the digital temperature sensor was the better choice. Breadboard testing was very easy to use because hooking up the sensor to a breadboard only required the pins being connected and the 4.7k pullup resistor to be in place. Data capture when breadboard was also easy to use because of the many available libraries using the one-wire bus communications. Overall the DS18B20 digital temperature sensor is not only more accurate, but also the better choice for this project. Multiple temperature sensors may be considered in the future, and right now the DS18B20 is the best choice for accuracy and ease of use.

### 5.8.2.3 Temperatures Control options

One of the key features of the project is utilizing the multiple ways to cool the system. The closed system with all the components requires the temperature in the box to stay cool to mimic room temperature. Because of this there are multiple ways to cool the different components in the box.

One option was to utilize a cooling plate. This could have been either for the laser or for any other electrical components. The cooling plate also known as a “cold plate cooler” is a cooling plate that allows an object to be directly attached to it. Because of the direct contact to the plate, the transfer of heat occurs directly and allows for maximum efficiently to allow conduction to the thermoelectric module. This then keeps the object operating at the desired temperature which can then allow the device or object to have maximum effort to stay stabilized and accurate because of the temperature control of the cold plate cooler. The figure below shows an example of a cold cooling plate. This particular place is a CP-031 from TE technology which costs about \$150.



**Figure 68: Cold Cooling Plate (permission requested from TE technology, inc)**

This cold cooling plate in particular utilizes a fan that is attached to the bottom of the plate where a heatsink with vents is then attached to the fan which then the object is finally attached to the plate that is connected to these two parts. This cold cooling plate in particular is great for smaller systems that only need a small amount of heat load to be regulated. This one in particular is great because it is only powered by 12DC which could be connected to a breadboard. It also consumes very little amount of power (28 Watts) which is great for systems that need as little power consumption as possible. This solution is great for systems that generate a lot of heat. One example of the Raman system that this project focuses on that could benefit from a cold cooling plate is the laser that is being used. This is because the laser could potentially be on for long periods of time. Because of this, the laser could potentially be hot or generate a lot of heat because it is on for long periods of time. Using a cold cooling plate ensures that the laser will stay cool. The Arduino Uno is also an option that can utilize this cold cooling plate, but usually the Arduino typically does not generate a lot of heat because of its design and because of it rarely has a huge load on it. The Arduino in general, regardless of how long it is on, should stay cool as needed. This cold cooling plate would only be needed if the temperature around the Arduino causes the Arduino to overheat. This plate then would allow the temperature around the Arduino to be higher, but still keep the Arduino from

overheating. Over all this is a great option, but was not used for this project because it is costly and also is not required because the heat being generated by the objects in the box does not justify the cost of using a cold cooling plate. Because of this, this option was not used.

Another option that was discussed was doing liquid cooling and using a radiator similar to how a water cooled pc setup is done. Liquid cooling is different from the use of air cooling. Usually air cooling is done by the utilization of many fans. Instead liquid cooling utilizes cooling filed tubes, a radiator, water blocks which are similar to heatsinks, and even some fans which are used to push the water around. One of the benefits of using liquid cooling compared to air cooling is that it allows the specific devices to be cooled to a much greater degree compared to air cooling. This means that the accuracy of cooling is much more efficient in water cooling than it is in air cooling. Another benefit of using a liquid cooling system is that the thermal transfer of heat between components is much better compared to conventional cooling methods. This is because heat is moved throughout the coolant rather than just typically being blow on devices or around the casing. Liquid cooling can also link components together and allow multiple components to be hit with the same liquid cooling system and the same water channel similar to an HVAC system. Another advantage of using liquid cooling systems is there is less overall noise in the system compared to using many fans. This is dependent though on if noise is preference or not. Cooling with liquid cooling also allows for temperature to be much more constant overtime. It allows for temperature regulation to be steady over a given time compared to using fans over because fans will require to ramp up or ramp down depending on the temperature and the load of the system.

With all this advantages of liquid cooling, there are also a good amount of cons. For example, liquid cooling is a lot more expensive than buying multiple fans. This can be bad for systems with smaller budget, it also is not an easy setup to create. Using liquid cooling requires the user to have knowledge of how to run the system. Because of this, it can cause complications and problems for a system. Another con is that if for any reason, there is a leak or water comes out of the cooling, the electronics could potentially be damaged by the liquid. Liquid cooling also requires room for installation which is not good for smaller systems. Fans used in the system typically require open space especially if a radiator is being used. A pump and layout must also be created to ensure that a liquid cooling “loop” is also being utilized which again requires physical space in the system.

Because of all these constraints and negatives, a liquid cooling system will not be utilized for the Raman spectroscopy system that is being created in this project. This is because the system does not generate huge amounts of heat which require liquid cooling. Liquid cooling would be overkill for a system like this project and would also affect the budget price as well. Liquid cooling is generally costly and the money for the project could be used in places that actually require higher cost like optical components. The system being built also does not have a lot of room within the closed environment because the optical components will need to be spread across certain distances. This means that liquid cooling could affect the path of the laser which affects the overall system. Because of this liquid cooling is not superior to the use of fans in our case. Even if case noise is louder with using multiple fans, noise is not a major contribution to the overall design constraints of the system. Liquid cooling is a great option for cooling

multiple components, but because this system does not generate too much heat even with the laser, fan cooling is the better option. Because of this fans are the better choice for this system.

Fans are the last cooling option that was considered for the system. Air cooling has been around for ages and is used very commonly in HVAC systems, but also in normal cooling. PC systems generally use fans to blow hot air in and out of the system. Air cooling is a very easy solution to cooling electronics because it does not require a lot of work on the system, but also does not require a lot of power to power the fans. Typically fans especially pc fans run on anywhere between 5 to 12V DC. For the fans used in this Raman spectroscopy system, they run on 5V dc source, but this is discussed further in the next section, *Fan specification and other options*. Air cooling is great because it does not require a lot to create a decent cooling system. There are many pros and cons to using air cooling. One advantage is that air cooling is cheap. Air cooling does not require a lot of money because fans are typically very cheap. This is great for projects that have a small budget but need to keep components cool. Another great advantage about air cooling is that fans are easy to wire. Most of the time fans are 2 pins which is your power and ground, but there are also fans that utilize 3 or even 4 pins. These fans typically are for systems that wish to utilize Pulse Width Modulation (PWM). PWM is being utilized in this system, but is discussed in a later section. Another advantage of using air cooling is that multiple fans can be hooked up to a single circuit, they only require power. This means that systems can utilize many fans setups without needing huge amounts of power. One option is to use fans that have a higher CFM rating where they push more air into or out of the case. This is great because even fans that are bigger are still much cheaper than other cooling options.

One problem with using air cooling is that it can get noisy, but if this isn't a constraint in the designing of the system, then this doesn't matter as much. Another problem with using air cooling fans is that they are not as efficient in cooling compared to other cooling options. This is because even though fans can push air into and out of the case, the rate at which this is done will depend on how much heat is being generated, how fast your fans are running, and the overall design and air flow of the system. Because of this, for systems that generate a lot of heat, air cooling isn't always a good option. Air cooling can potentially require more fans if the system generates too much heat and even if more fans are being added to the system or the fans have higher CFM ratings, the degree of temperature difference may not have a huge impact on the amount of fans being added. Sometimes a system can generate too much heat that air cooling isn't the best option. For the system that is being built in this project, air cooling is a suitable option because the system being built does not generate a lot of heat. This means that air cooling can achieve desired temperature constraints because we only need the components that generate a lot of heat to have cool air being blow across them. Air cooling also doesn't put a dent into the budget of the project because typically fans are much cheaper than other cooling options. One part of the project is to utilize either positive or negative pressure. Positive pressure is when more fresh air is coming into the system than there is hot air exiting the system. This means that the CFM of the intake fans must exceed the exhaust fans in order to create a positive pressure system. Negative pressure however is the opposite. It requires that the air coming into the system isn't as

much as the air leaving the system. This means that the CFM ratings of the fans must not exceed the exhaust fans.

With all this being said air cooling was the suitable design choice for this system. The constraints required temperature cooling to be low cost, and does not require something to cool components at such a high level of accuracy. Even though other cooling options are great, they are something that is not necessary for the system that is being built for this project.

### 5.8.3 Temperatures Control Options

#### 5.8.3.1 *Fan specifications & other options*

Air cooling was the decided design choice for this system. Because of this fan options and specifications need to be discussed. The first design choice was choosing the right fan for the job. The fans chosen must have the following design constraints:

- Must be fairly small, nothing greater than 6 inches in height.
- Must not be too noisy
- Must run at 5V
- Must supply as much CFM as possible
- Must pull as small of a load as possible.
- Must not be expensive, preferably a fan under \$10.

With all this being said, the fans chosen must fit these design constraints defined by the group. Three fans were considered for the project. The figure below shows the first fan being considered. It is the MultiComp MC36313 Axial, brushless motor fan. This fan runs on 5V DC, is only 35mm by 6mm and only draws a maximum of 85mA. It is a 2 wire fan that is only used for power and ground. In terms of price, this fan is only \$2.63 which is fairly cheap. This fan was considered because it fit all design constraints. The main concern of this fan was its build quality. Judging by its pictures, it looked fairly cheap and also looked as though it was not able to supply a decent amount of air flow. From the specifications, the fan was only able to output an air flow of 4.3 cu.ft/min which is not bad, but other fans can be considered.

The figure below shows the second option for choosing a fan was the MultiComp MC36301 axial, brushless motor fan that runs on 5V DC, is only 25mmx6mm and has a maximum load of 115mA. Its power rating is 600mW and can push out 3cu.ft/min. This is a great fan choice because it not only fits all the design constraints, but it also pushes a decent amount of air flow for its size and speed. This fan is also only 2 wires which are power and ground, but this fan is fairly pricey compared to other fans. This fan is \$10.68 which is much more expensive than other fans. Just buying 3 of them would be a little over \$30 dollars. This is too much to spend on the budget and it is preferred to find fans that are at least half the cost of this fan. Overall this fan was a great choice, but was too much money for the project.

The last and final option was the MultiComp MC36258 axial, brushless motor fan that runs on 5V DC, is 40mmx20mm, pushes 7.7cu.ft/min and only draws a maximum load of 140mA. This fan was the perfect choice because it fit all the design constraints of the system, but also pushed out the most air. This fan was a little large compared to the other fans, but not enough to be an issue. Another great aspect of choosing this fan was

the fact that it only drew a maximum of 140mA. This is a very small load for the power supply being used to power everything which is a 5V DC power supply that can draw up to 2Amps of current. Finally, this fan was also fairly cheap. It was only \$5.19. This is half the price of the prior fan, and had better overall specifications. The build quality looked to be sturdy compared to the first fan. Because of this, this fan model was the chosen fan model that is being used in the project. 3 Fans were ordered where 2 will be used and 1 is a backup as needed. 1 fan will intake air, while the other fan will be the out take fan. The figure below shows the fan that was chosen for the project.



Figure 69: Fan Option 1



Figure 70: Fan Option 2



Figure 71: Fan Option 3

#### 5.8.4 Circuit Analysis & schematic

In order to control fans to from the Arduino Uno, a transistor was used to allow pulse width modulation to occur as well as to allow the transistor to act as a switch. An npn transistor was used. The figure below shows the general schematic that is used for allow an Arduino to control a can via the digital pins.

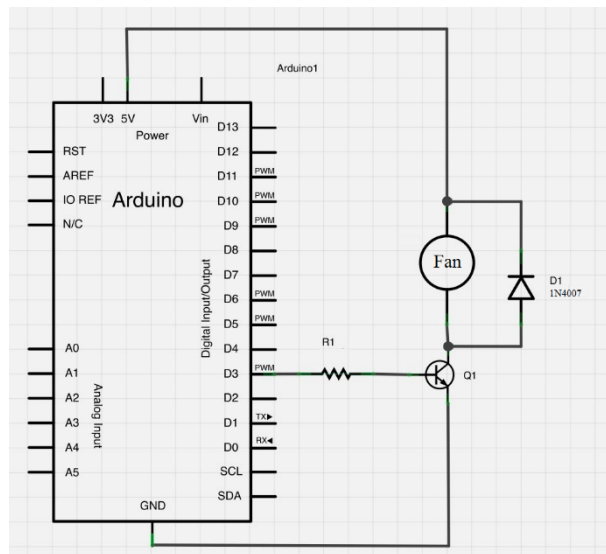

Figure 72: General Schematic for controlling a fan through Arduino Uno

As you can see from the figure above, the R1 component, the transistor and the diode need to be chosen with given calculations to make sure that the components can handle the system and are chosen to actually work for the system. The first calculations that needed to be done was choosing the correct transistor to allow optimal switching and biasing for PWM control. 2 transistors were considered for this. The first transistor was a

general purpose PN2222A npn transistor and the other was a BC547 npn transistor. The figure below shows the PN2222A and the BC547. The PN2222A transistor is a general purpose transistor that has a maximum collector to emitter voltage ( $V_{ce}$ ) of 40 V and a maximum current draw of 600 mA where  $\text{Beta} = 10$ . So far judging by these specs alone, the PN2222A should be able to handle the load of the fan.

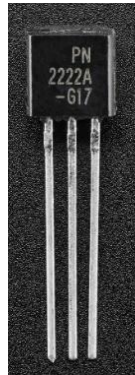

Figure 73: PN2222A NPN transistor



Figure 74: BC547 NPN transistor

In order to verify this, calculations must be done. Below are the following calculations used to verify if the PN2222A npn transistor is suitable for handling the fan.

$$v_{Load} = 5V$$

$$i_{Load} = 115mA = .115A$$

$$I_{c(max)} = 600mA$$

$$V_{ce} = 40V$$

$$I_c = 10 * I_b \text{ where } \text{Beta} = 10$$

$$\text{Setting } .115A = 10 * I_b \rightarrow I_b = .0115A = 11.5 \text{ mA.}$$

This means that the current in  $I_b$  will be almost 12mA which works for the Arduino Uno pins because they can supply a maximum of 40mA. This means that this transistor can be used to handle the fan as a switch and allow the Arduino to control the fan. Using this we can then calculate the resistor that is needed that connects from the Arduino pin to the base of the transistor to ensure the current supplied puts the transistor in saturation mode as either completely on or completely off. To calculate the resistor ( $R_1$ ) that is needed the following calculation is done:

$$V_{cc} - V_{be} = 5v - .6V \text{ (from the datasheet)} = 4.4V$$

$$\text{Then } V = I * R \rightarrow R = \frac{V}{I} = \frac{4.4V}{12 \text{ mA}} = 366 \Omega$$

This means that we can use a 366  $\Omega$  resistor in between. A 360  $\Omega$  resistor was used in the breadboard and design which worked perfectly. Finally, a diode must be used to protect the circuit from any inductive kickback of the motor. This means that if the transistor acting as a switch was to switch off the current in the motor which has some form of inducing, then it will create a voltage necessary to keep the current flowing.

Because of this a when the transistor shuts off quickly, current must still flow through the motor during the time it is slowing down which means any left over current will flow through the diode and protect the circuit from generated electricity. Without the diode, the transistor could potentially burn out. This same circuit was used for both fans. Pins 5 and 6 where used on the Arduino Uno specially for PWM modulation.

One of the design constraints was to take the digital temperature sensor discussed prior and use it to allow the fans to operate at different voltages so different speeds of the fan will be used. The concept of doing this is using the pulse width modulation from the pins of the Arduino that was discussed earlier. The table below shows the relationship between the pulse width modulation and the voltages of the fans. The temperature Range described below are purely dummy values and will not be the actual temperature ranges. These values will be determined once temperature testing has occurred for the closed system. The table below shows the duty cycle and the fan speed for pulse width modulation.

Duty Cycle	Voltage	Temperature Range	PWM Value	Fan Speed
0	23mV	Less than 26 C	0	0
30%	.778 V	26 C	72	30%
40%	1.123 V	27C	102	40%
60%	2.553 V	28C	153	60%
80%	3.753V	29C	204	80%
100%	4.42 V	30C	255	100%

**Figure 75: Temp Sensor Voltage, RPM, Duty Cycle Comparison Chart**

One problem that occurred was that the fans would make a noise. In order to overcome this obstacle, and RC filter was placed at the base of pin 5 and 6 in order to smooth out the PWM signal that was coming from the Arduino Uno pins. In order to design this, calculations were needed to pick the right values for the resistor and the capacitor. The figure below shows the frequency that is generated from pins 5 and 6 which is 980Hz. Using this, we can then calculate values for R and C that has a decent settling time and response time. The figure below shows the settling time and response time calculated that was suitable for the needs of the project. Because of this, the circuit did not need the 360-ohm resistor across the base.



**Cut-off frequency**

$f_c = 1.5392160840609[\text{Hz}]$

**Final Vout value of the step response (without a ripple)**

$g(\infty) = 2.5[\text{V}]$

**Peak-to-peak ripple voltage**

$\Delta V_{\text{pk-pk}} = 0.012335663599382[\text{V}](\text{Duty}=50\%)$

**Settling time 0%→90% (0V→2.25V) (without a ripple)**

$t_r = 0.23808729861558[\text{sec}]$

$f_{\text{PWM}} = 980$  [Hz]  
Duty Step 0%→50 [%]  
PWM signal voltage:  
 $V_L = 0$  [V]  $V_H = 5$  [V]

**R and C values of filter | Cut-off frequency**

Cut-off frequency  $f_c =$  [ ] [Hz]  
 R and C values  
 $R = 220$   $\Omega$        $C = 470\text{u}$  F

p:pico, n:nano, u:micro, k:kilo, M:mega

**Calculate**

**Figure 76: Shows the RC Filter Calculations**

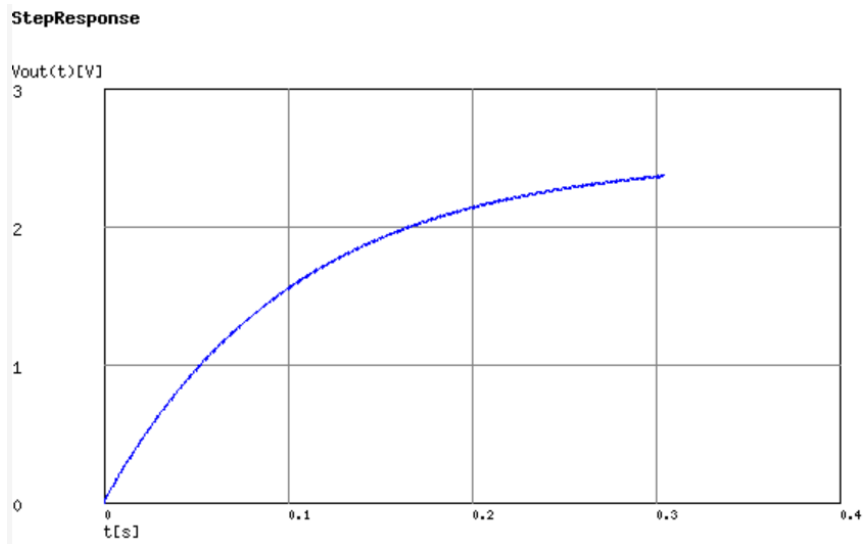

**Figure 77: Shows the Step Response of the RC Filter**

Finally, the circuit below, The figure below shows the temperature sensor as well as both fans connected to the Arduino Uno's pin 4 for the temperature sensor, pin 5 for the intake fan, and pin 6 for the exhaust fan. The circuit below shows all components calculated and used in the circuit. The figure below shows the circuit breadboard tested.

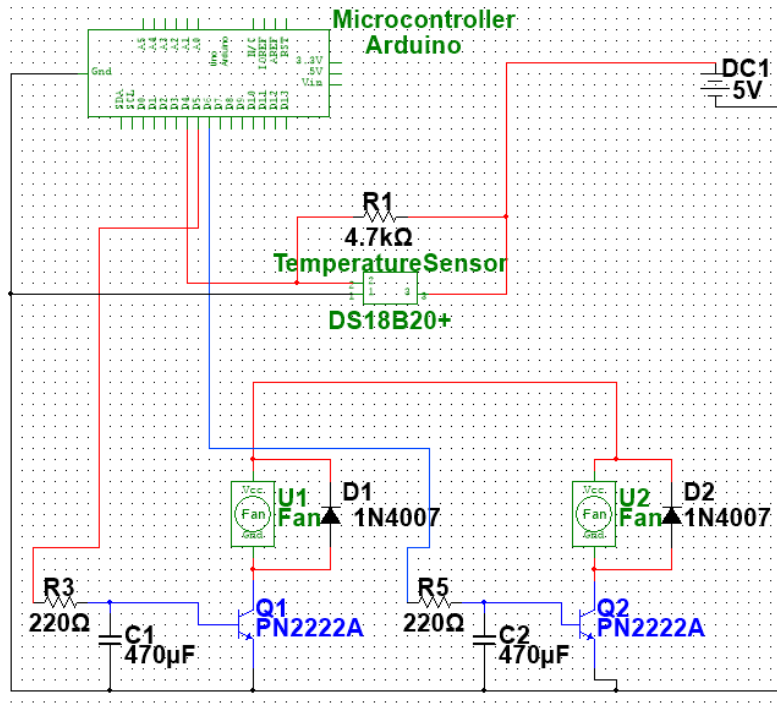

Figure 78: Circuit showing the digital temperature sensor, the intake fan, and the exhaust fan

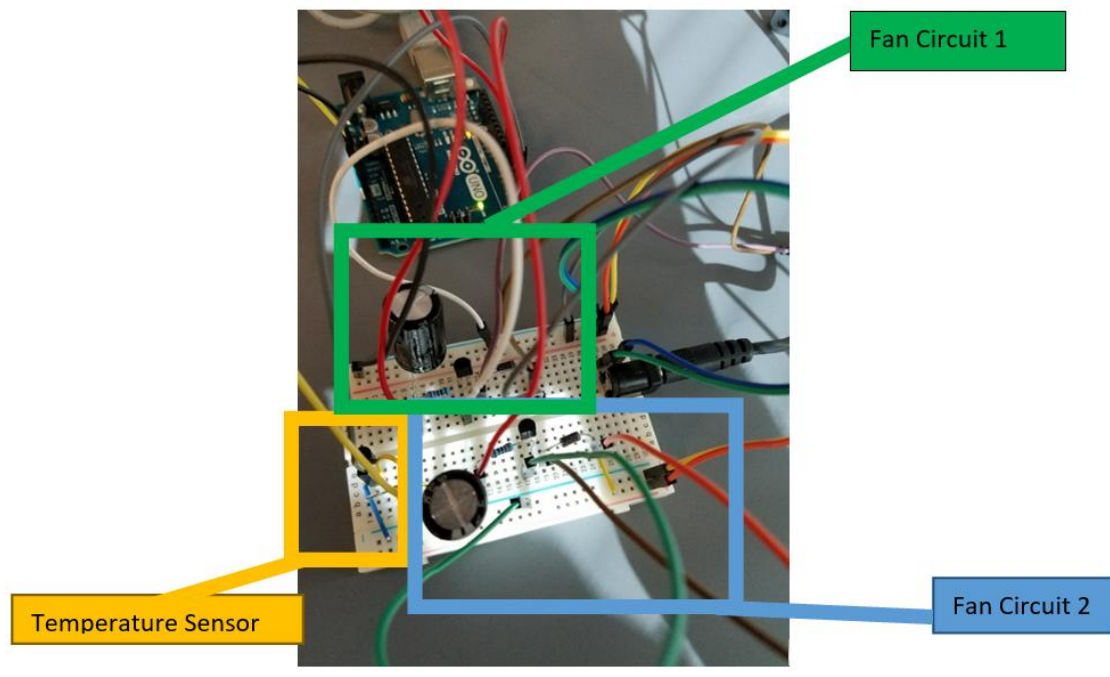
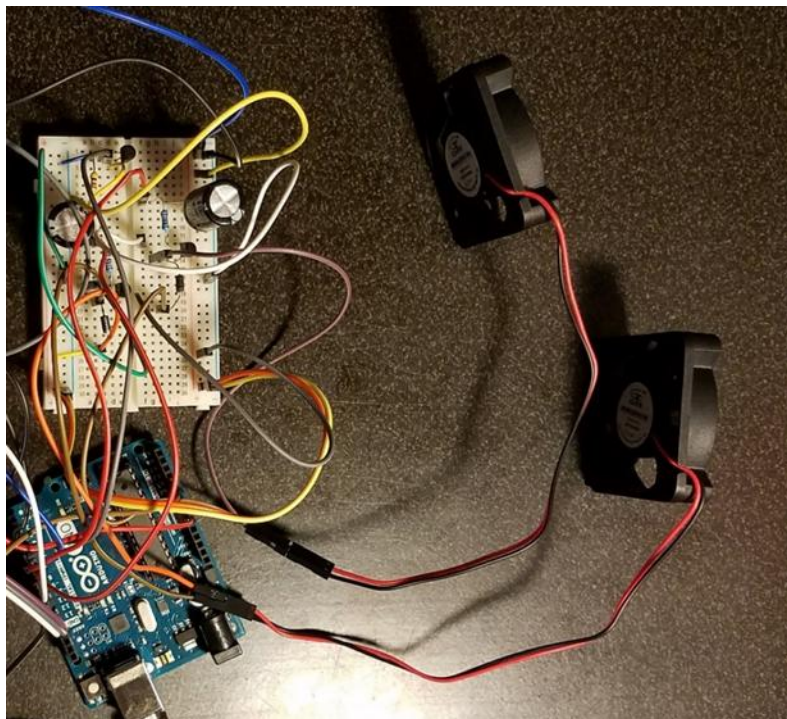

Figure 79: Breadboard testing showing the circuit only



**Figure 80: Breadboard testing showing the temperature sensor, the intake fan, and the exhaust fan**

## 5.9 LASER BLOCKING

### 5.9.1 Laser Blocking Specifications and Purpose

One aspect of the project is that the laser must be blocked in order to retain a class 1 laser system. This means that the laser cannot be science physically. The problem with this is that when a sample is on the stage, the laser can be seen. To overcome this, a sliding door will be placed in front of the sampling stage and when the sliding door opens to allow the user to insert a sample, the laser must no longer be showing. In order to keep the laser on but not show the laser on the sampling stage, laser blocking must occur. The laser cannot be turned off and on because it will not only damage the laser because it is constantly being turned off, but the laser cannot be turned on and off because for maximum use we want the laser to stay warm to its settling point. In order to achieve this a device must be used to allow laser blocking occur.

In order to achieve some sort of blocking. The project design requires that a panel be moved in order to block the laser. 4 different parts were considered in order to move a panel in front of the laser beam. The following are the 4 different parts:

- Dc Motor
- Stepper Motor
- Actuator
- Solenoid

In order to achieve laser blocking, the single most important design constraint is speed. The laser beam must be blocked as soon as the slider is opened. Because of this we need a moving device that is quick enough to block and unblock. Each of the 4 different parts above are able to move the panel, but the characteristics on how it moves the panels and the constraints that the panel moving has affects achieving the design constraints.

## 5.9.2 Laser Blocking Parts

### 5.9.2.1 DC Motors

One of the 4 parts that can be used to move the panel to block the laser is a DC motor. A DC motor standard for Direct Current motor. A DC motor works on the principal that when a current carrying conductor is placed in a magnetic field, a torque is experience on the conductor which allows for the conductor to move. This is defined as a motor action which when applied with mechanical components, can create what is called a DC motor. The figure below shows a typical 5V DC motor.



Figure 81: 5V DC Motor

Depending on how the DC motor is wired can depend on the direction that the motor turns. There are 3 major characteristics of DC motors which are speed, torque, and power. Each of these have a relationship between each other. The main aspect that affects the overall design of this project is the speed. In the designs aspect, torque and power are not directly related to what is desired. For example, having a DC motor that is powerful is great for driving loads that have a high demand, but for the case of the project, the only load is a light panel that requires movement. Because of this needing a powerful DC motor is not suitable for the project. Another aspect of a DC motor is the torque. Torque is necessary for the motor but for this project there is no design specifications that require a fast or huge range of torque. Again the only specification is to move a panel, therefore having a motor that is heaving on torque rotation doesn't help the design specifications. Finally, the last and most crucial component is the speed of a DC motor. Usually, DC motors can spin fairly fast. For this project in particular we need the DC motor to be able to stop and start fast and accurately. Unfortunately, in order for a motor to be able to stop and start fast with accurate positioning, those motors can be very expensive which affects the budget of the project. Because of this DC motors were not considered because a fast part is needed to be able to turn on and off quickly. A DC motor that can move in increments could be a better application. This leads to using a stepper motor.

### 5.9.2.2 Stepper Motors

Stepper motors are another option that was considered in the design process of picking the right parts. Stepper motors are dc motors that can stop and start at given positions or angles of a full 360 circle. This means that a stepper motor can start at position or angle 0° and move and stop at the 45° or even at smaller increments depending on the resolution or number of steps per rotation. The figure below a typical 5V DC motor that can be used with an Arduino Uno and is powered by only a power pin and a ground pin.

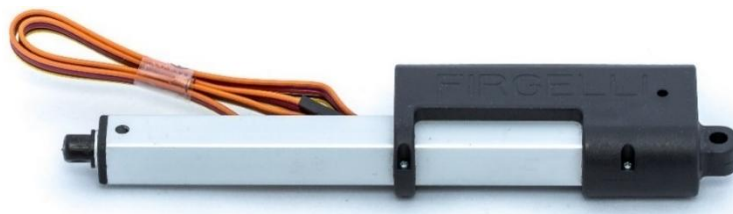

**Figure 82: 5V DC Stepper Motor**

A stepper motor can be a solid choice for this project because the motor can have the panel rotate. These devices are considered constant power devices which means they can stop and start quickly, but to have a stepper motor with accuracy, it will require a stepper motor that will cost more. Another aspect of stepper motors is that they tend to be noisier than DC motors. This is because when a step is made on a motor, the motor will snap from one position to the next. When this occurs this will cause the motor to vibrate. This is something that can cause problems to the system because we want all motors and rotation to be stable and vibration can affect the stability of the system. Even though this is a viable solution for the project, it is not the best. The project calls for a laser beam to be blocked fast. This means the stepper motor must be accurate, precise, and fast which can drive the cost of the motor. Overall this is a viable choice, but was not the choice that was decided for the project.

### 5.9.2.3 Actuators

Another option that was considered to block the laser was using a linear actuator. A linear actuator is a mechanical device that converts energy and uses the energy to create a force or motion in a straight line. This line can be in any direction, but the actuator applies a force which is either a pushing, pulling, lifting or clamping. Linear actuators are basically a piston which is a sliding piece that is moved by some force like air pressure. The figure below shows a linear actuator that was considered for the project.



**Figure 83: Linear Actuator**

## Linear Actuator

Linear actuators are a viable solution to pushing and pulling a panel to block a laser beam. One problem that a linear actuator has is that they can typically be slow. In order to have a fast pushing and pulling linear actuator, typically the cost for such linear actuators with precision and accuracy can be very expensive. This causes problems for the project because it affects the budget. Another aspect is that a design constraint of the project is to keep the electronics with a 5V power source. This can affect a linear actuator because if the linear actuator is slow using a 5V power source, then this can affect the timing of pushing the panel which means it does not fit the design constraint of having a fast motion laser blocking. Though linear actuators are a viable source for this project, a linear actuator that is fast and precise must be needed. For our budget, this can affectively drive the cost which unfortunately is not an option for this project. Instead, the last option that was considered allows for price linear movement in a fast and accurate motion. This device is called a solenoid and is similar to a linear Actuator.

### 5.9.2.4 Solenoids

The last option that was not only the best choice, but also fit the design constraints of having the laser beam blocked by a panel in a quick and fast motion was by using a solenoid. A solenoid is an electromagnet that is made of a coil of copper wire. It has a slug of metal known as an armature in the middle where once the coil is energized the armature is then pulled/pushed into the center of the coil. Because of this the solenoid is able to pull and push from one end to the other. This is done very rapidly and precise because it is designed to move quick from one end to another. Because of a solenoid is a viable solution in blocking a laser because the solenoids length can be long enough to block the laser, but also can quickly pull back. This allows quick movement when the contact switch is open and for quick blocking of the laser. The figure below one shows the solenoid used in the design.

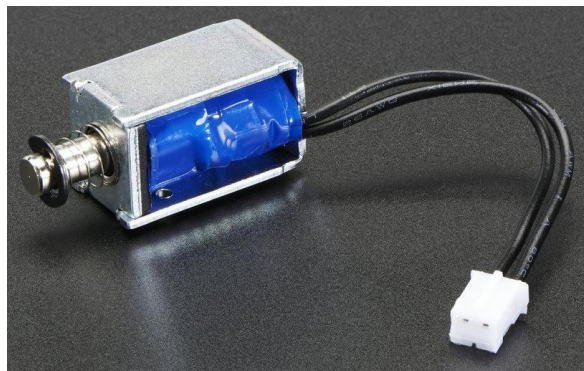

**Figure 84: 5V DC mini push-pull solenoid**

This solenoid that is being used is a very small solenoid that is 20mm long. It is activated on a 5V DC power supply and when the voltage is removed, the spring returns to its original position. This solenoid in particular is perfect for this projects application because it does not need to be a large solenoid to be affective. It only needs to be a quick response solenoid that is fast and accurate. The solenoid draws about 1.1A which is way more than the Arduino Uno can supply. Because of this a transistor must be used to drive the solenoid and allow Arduino to turn the solenoid on and off by using a transistor as a

switch similar to the temperature fans. This is discussed more in section, *Solenoid Specifications and Justification*. Another great aspect of using this particular mini push-pull solenoid is that it is cheap. This solenoid in particular only costs \$4.95 which is cheap and still gives the results that are needed in the design. This means that it does not drive the cost of the project barely at all or affect the budget which makes this the best option for blocking the laser. Overall solenoids are a viable option for any project especially in this Raman system. It is a low power, cheap, and effective solution.

### 5.9.3 Solenoid specifications & justification

#### 5.9.3.1 Circuit Analysis & schematic

The first calculations that needs to be done was choosing the correct transistor to allow optimal switching and biasing for PWM control. 2 transistors were considered for this. The first transistor was a TIP120 Darlington npn transistor and the other was a BC547 npn transistor. The figure below shows the TIP120 Darlington npn transistor and the BC547. The TIP120 npn transistor is a Darlington transistor that has a maximum collector to emitter voltage ( $V_{ce}$ ) of 60 V and a maximum current draw of 5A where  $\beta = 250$ . So far judging by these specs alone, the TIP120A should be able to handle the load of the solenoid.

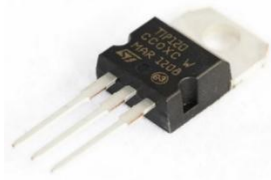

Figure 85: PN2222A NPN transistor



Figure 86: BC547 NPN transistor

In order to verify this, calculations must be done. Below are the following calculations used to verify if the TIP120 npn transistor is suitable for handing the motor.

$$v_{Load} = 5V$$

$$i_{Load} = 1.1A$$

$$I_{c(max)} = 5A$$

$$V_{ce} = 60V$$

$$I_c = 250 * I_b \text{ where } \beta = 250$$

$$\text{Setting } 1.1A = 250 * I_b \rightarrow I_b = .0044A = 4.4 \text{ mA.}$$

This means that the current in  $I_b$  will be almost 4.4mA which works for the Arduino Uno pins because they can supply a maximum of 40mA. This means that this transistor can be used to handle the motor as a switch and allow the Arduino to control the motor. Using this we can then calculate the resistor that is needed that connects from the Arduino pin to the base of the transistor to ensure the current supplied puts the transistor in saturation mode as either completely on or completely off. To calculate the resistor ( $R_1$ ) that is needed the following calculation is done:

$$V_{cc} - V_{be} = 5v - 1.5V \text{ (from the datasheet)} = 3.5V$$

$$\text{Then } V = I * R \rightarrow R = \frac{V}{I} = \frac{3.5V}{4.4mA} = 800\Omega$$

This means that we can use an 800  $\Omega$  resistor in between. A 1k $\Omega$  resistor was used in the breadboard and design which worked perfectly. Finally, a diode must be used to protect the circuit from any inductive kickback of the solenoid. This means that if the transistor acting as a switch was to switch off the current in the solenoid which has some form of inducing, then it will create a voltage necessary to keep the current flowing. Because of this a when the transistor shuts off quickly, current must still flow through the solenoid during the time it is slowing down which means any left over current will flow through the solenoid and protect the circuit from generated electricity. Without the diode, the transistor could potentially burn out. This same circuit was used for both fans. Pins 12 was used on the Arduino Uno.

Finally, a magnetic contact switch that was connected between pin 2 and ground was used to allow when the solenoid would push out or pull in. In order to do this, either an external pull up or pulldown resistor must be used to get rid of any floating values of the contact switch. Another alternative is to use the internal pullup resistor that can be assigned via Arduino code. The figure below shows the contact switch being used in the circuit.

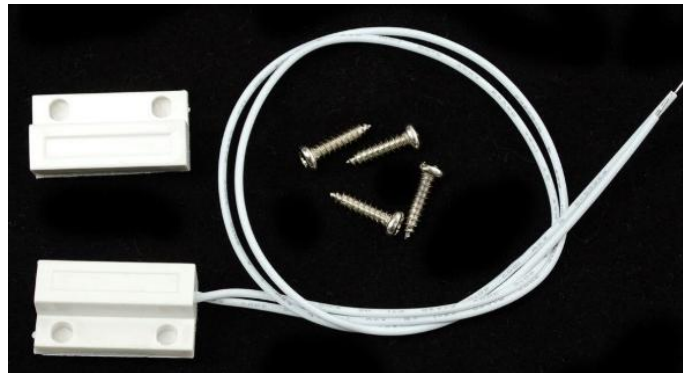

Figure 87: Contact Switch used to allow when the solenoid turns on or off. (permission request from adafruit)



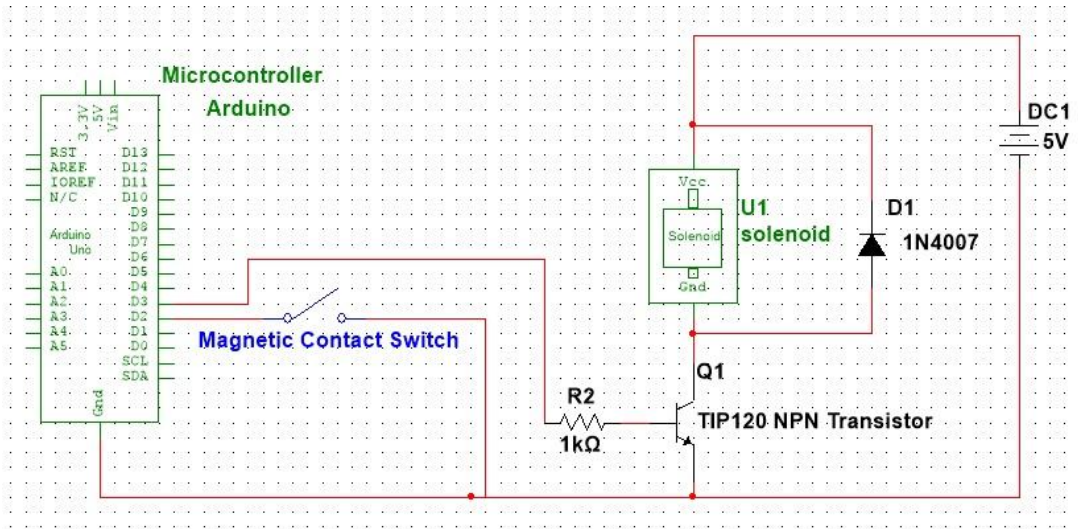

Figure 88: Circuit design for laser blocking using a solenoid and a contact switch

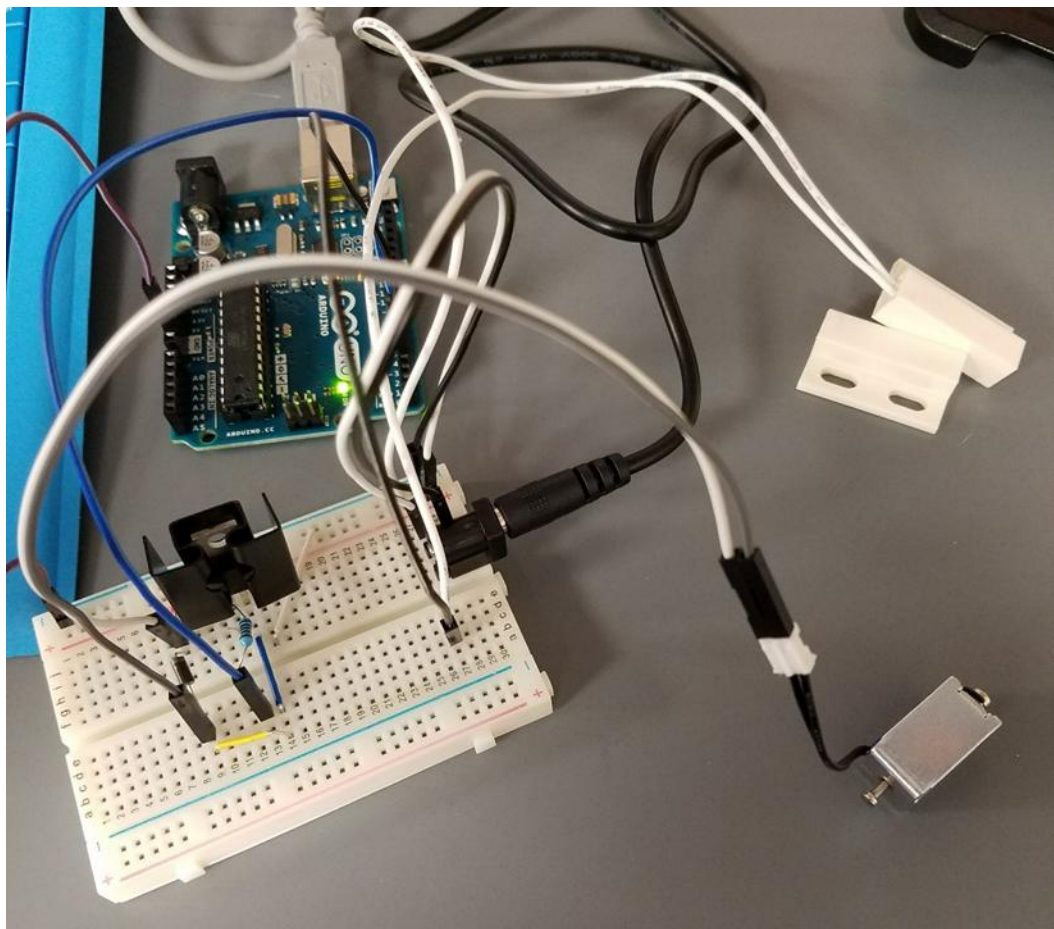
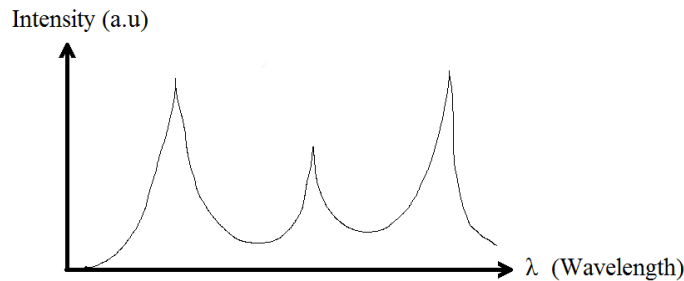

Figure 89: Breadboard Testing for Laser Blocking using Solenoid and Magnetic Contact Switch

## 5.10 BACKLIGHT CONTROL

### 5.10.1 Backlight Use Theory and Purpose

One of the main specifications that must be accounted for is the use of an optical backlight that was provided from the sponsor. This backlight is a 24V DC, 1.5A backlight that must be controlled via the Arduino Uno microcontroller. The theory behind the backlight actually goes back to the camera. In previous discussions a camera is used to see a sample region. This is needed because this is the basis of Raman spectroscopy and even general microscope sampling. The camera is also needed because it is used to see the laser spot. With these to items being said, the backlight will allow a spectral acquisition to occur on a user defined location because it allows for an image to be seen. This means that the camera has a complete dependency on a backlight being present. Without the use of a backlight, the spectrum being created will have interference because there is more background interference in the spectrum. The figure below shows a general spectrum that is correct without any background interference added in the spectrum while the figure below shows a spectrum that has background interference.



**Figure 90: Spectrum with the use of a backlight**

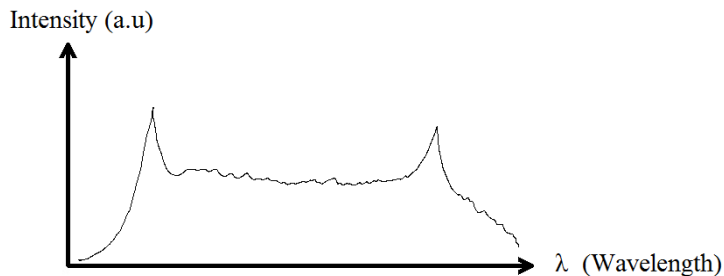

**Figure 91: Spectrum without the use of a backlight**

This shows that in order to even see a camera image, a backlight is needed. Basically, the camera will be showing the sample on a stage which then an image will be taken of this backlight, in order to see the image a backlight is needed or else the image coming from the backlight will be completely dark. This is a complete necessity to Raman spectroscopy. Without this, the image will not be able to be seen. The figure below shows the backlight that will be used in the Raman spectroscopy system.



**Figure 92: 24V DC, 1.5A Backlight**

### 5.10.2 Circuit Analysis and Schematic

Controlling the backlight is the same as controlling a motor or a solenoid. To control the backlight, a transistor was used as a switch to allow the power coming from the source to flow through the backlight to be turned on and off as needed when the Arduino Uno send the signal from its pin. The power source that is required to power the backlight is 24V DC with an applied load of 1.5A draw. This means that a transistor that could allow such voltage was needed. Luckily from previous sections, it was established that there is in fact a transistor that can allow this kind of voltage. A TIP120 NPN Darlington transistor was used as a switch for turning on the backlight on and off.

In order to verify this, calculations must be done. Below are the following calculations used to verify if the TIP120 npn transistor is suitable for handing the backlight.

$$v_{Load} = 5V$$

$$i_{Load} = 1.5A$$

$$I_{c(max)} = 5A$$

$$V_{ce} = 60V$$

$$I_c = 250 * I_b \text{ where } \beta = 250$$

$$\text{Setting } 1.5A = 250 * I_b \rightarrow I_b = .006A = 6.0 \text{ mA.}$$

This means that the current in  $I_b$  will be almost 6.0mA which works for the Arduino Uno pins because they can supply a maximum of 40mA. This means that this transistor can be used to handle the backlight as a switch and allow the Arduino to control the backlight. Using this, we can then calculate the resistor that is needed that connects from the Arduino pin to the base of the transistor to ensure the current supplied puts the

transistor in saturation mode as either completely on or completely off. To calculate the resistor that is needed the following calculation is done:

$$V_{cc} - V_{be} = 5v - 1.5V \text{ (from the datasheet)} = 3.5V$$

$$\text{Then } V = I * R \rightarrow R = \frac{V}{I} = \frac{3.5V}{6.0mA} = 583\Omega$$

This means that we can use a 583  $\Omega$  resistor in between the pin and the transistor. A 1k $\Omega$  resistor was used in the breadboard and design which worked perfectly. Finally, a diode must be used to protect the circuit from any inductive kickback of the backlight just in case. While this may not be needed, a diode was used for general safety of the circuit.

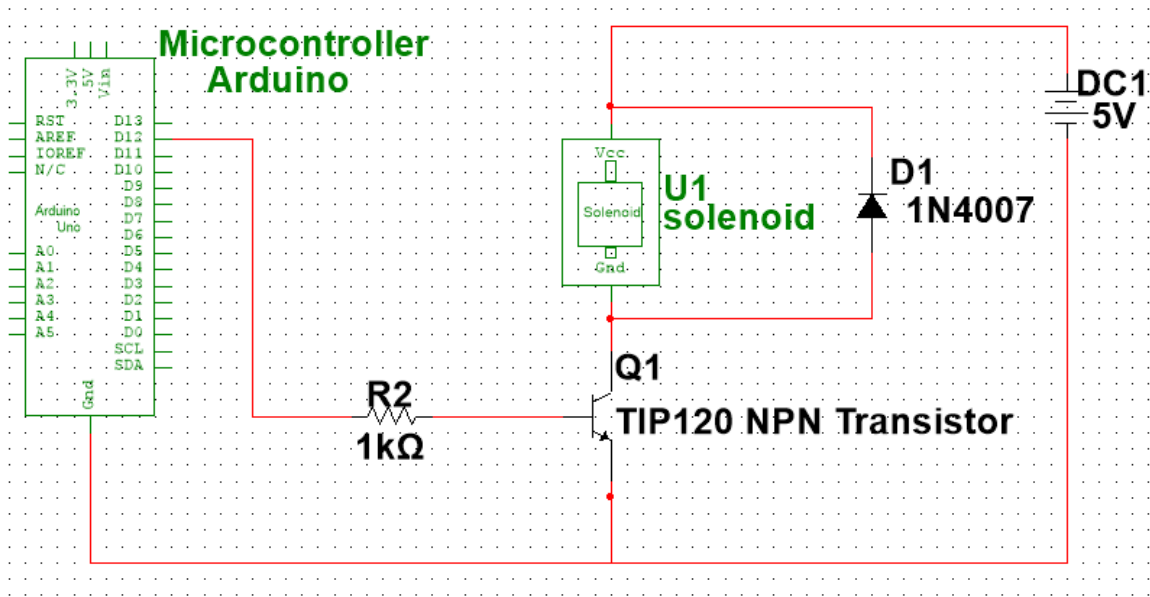
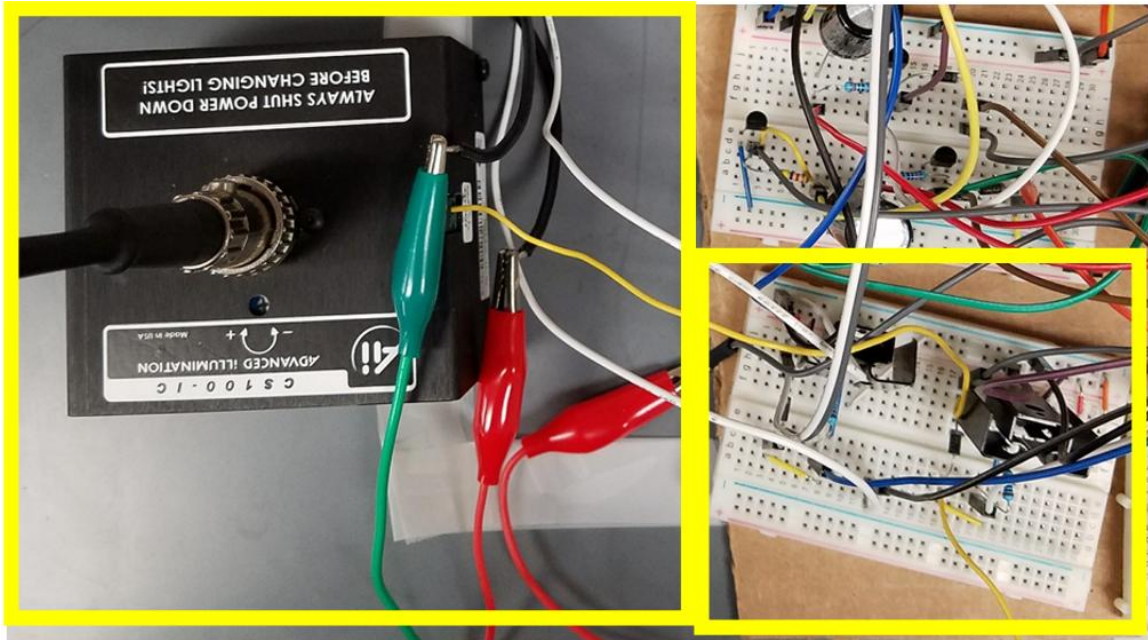

Figure 93: Circuit Schematic of the Backlight



**Figure 94: Breadboard testing of Backlight Control**

### 5.11 SOFTWARE DESIGN

The section introduces and discusses the importance of key roles in the software design process. This provides a thorough layout from start to finish of each step used to create the MATLAB Graphical User interface (GUI). There are 5 steps in the design process. The steps are as follows: Requirements, Design, Build, Test/Debug and Final Analysis. This is an in-depth detailed process of refining one's analysis of the original problem to find and execute a very specific set of parameters. Each step is tailored to break apart the large-scale set of goals into sets of smaller, easier-to-handle goals. This creates a fine filter that can help the developer design the whole system into smaller subsystems. Through this process, the software design can be tried and tested against the most rigorous of variables to create one of the best viable options for a GUI. This creates a template of main features that is used repeatedly in each stage from higher to lower-level code throughout the system. In each step, the template is examined from a different perspective with respect to the parameters needed for each particular phase. This allows for a detailed analysis of every step needed to complete the whole process ahead of time to then be able to make an accurate assumption of time, budget, application, and skill set necessary for the complete scope of the project. By asking all the questions ahead of time and doing the detailed research, this side-steps a lot of unforeseen errors that can come to light later on in the build. This eliminates most aspects of the trial and error process and theoretically should reduce errors and time wasted troubleshooting at the end of the design. As with any designer, the more detailed and experienced they are with this process, the better chance they have at predicting roadblocks for the future of any design. This, however, gives a replicable process that can be practiced overtime and developed like a muscle. One of the largest mistakes developers make when starting a design is not doing the proper research to the right extent on the problem before diving into their build. Research plays a vital role in the large-scale aspects of the design. In any machine, every process has to be developed as a part of a whole than it can be easily integrated and

editable. The more independent each subsystem can become before putting them all together the easier it is to fine tune towards the end of the build. Through following this process with proper planning and accurate execution the sum of the parts will add up to a much more Integra table and tangible system.

The first stage and possibly the most easily overlooked and underappreciated in the average individuals design process is the requirements stage. The requirements stage sets the template for the whole project without it the project will have many disconnects that will come back around to create massive errors when testing and debugging at the end. If done correctly with in-depth detail the rest of the projects is basically repeating the template and looking at it from different directions. Therefore for the best success any individual using this template should put a higher level of detail and respect into this part of the process. The requirements section is a full layout of asking the correct questions the who, what, when, where and why of each individual task that software is planning to implement. This is not just how the software implements, but how it executes with respect to each aspect of hardware and every subroutine that it has to interact with. This can be quite a large scale process which is why it is important to do all the research ahead of time. Than the best fit comparison can be identified before time is wasted going down any rabbit trails. First the problem that is trying to be solved must be defined and then it must be broken down into smaller problems. This is the basis of the whole requirements stage what are the questions you have to ask yourself and answers to the questions to build the project step by step?

The project the group embarked on was to build a ramen spectroscopy test set up. This was a very large scale project to take on with many different variables to consider. The software side alone is quite the feat to design and execute and has many different variable requirements to look into with respect to a large scale of different components. There were 5 major sections outlined in the requirements section. These sections were hardware, display data, controls, back end code and the general system requirements. These are the major factors for the design without the proper knowledge of how these all interact it would be a waste of time to move forward. Problems can occur in many different ways and will occur so it best to make sure ahead of time that all of these components are picked appropriately to interface which each other as smoothly as possible.

The first question asked was what hardware to use with respect to software? This is a very important aspect of the design as with each set of hardware they have many different types of higher level coding and it is important to be familiar with how the code is used before taking on such a large task. Therefore we came across another question. What code could we all write in so that we could help each other when the project became more intricate? The top microprocessors that came into that scope was the Arduino, MSP430 and the mini-computer the Raspberry pi as they all used C. That became the jumping off point for comparison on which microprocessor to use. From there we researched each individual devices based on exactly what the needs were for the project when it came to communication with the laser, sensors and the computer interface. Next major question was what software package would be the best fit for the hardware. The two most widely used interfaces were LabView and MATLAB. Another

thing to consider when looking at the hardware and software was how these two software packages will communicate.

#### 5.11.1 Software Requirements

##### *5.11.1.1.1 I<sup>2</sup>C*

One of the main forms of communication that all of the processors have was the I<sup>2</sup>C bus. I<sup>2</sup>C bus is used by almost every microcontroller on the market now. It is used specially for integrated circuits. They use this concept because it is simple to integrate into the most complex designs. The concept allows the user to use the bidirectional lines serial data line (SDL) and serial clock lines (SCL). This allows designers to add in more components any point in the lines because there are more GPIOs (General Purpose Inputs/Output lines) directly connected to the microcontroller. This frees up space for many different things to communicate without problems to the microcontroller. This could come into handy for are temperature and power sensors and also pulling data from the spectrometer. The average bus can have roughly 100 nodes and only needs 2 electrical signals from the serial data line and clock line. Now by simply pulling out the component and programming the new address of the component to the micro controller the device can interact easily and without rewiring the breadboard or redesigning the PCB. The I<sup>2</sup>C bus has quickly taken over the market. As it is used for most devices that are light weight and compact. With the world changing to smaller integrated circuits the I<sup>2</sup>C bus is in almost every small compact device like cell phones or laptop computers.

##### *5.11.1.1.2 Serial*

The serial TTL communication Transmits (TX) and receives data (RX). This is a 1 pin digital communication. The average serial input has two options synchronous (clock) or asynchronous (without clock). The synchronous serial input uses a clock to create a rising edge and falling edges for everything to trigger with respect to highs and lows of a signal for ones and zeros. Asynchronous data is transferred without a clock it uses a bit package set up. This package is called a packet it can be anywhere from 8-32 bits. There is a first and last bit that initializes the decoder and a data pack in the center. The device only has one digital receive at a time therefore only one device will be able to communicate at a time with the Arduino. It also uses a USB interface to communicate with the computer. USB stands for Universal serial bus.

The USB is what connects the Arduino and MATLAB interface. It was designed as a cord that can make any device easily accessible. The cord uses both single and parallel communication to create connections between any two devices in milli-seconds. Most devices have ROM commands that once connected to any computer can initialize communication and send a set of commands that will automatically connect to the internet and download driver software for the device. This makes a device installation as simple as plugging into the computer. The Arduino software does this immediately after connecting to the computer. Once this cord was defined as the common for every device in the industry the communication of devices to computer interaction was revolutionized. Everything from cable modems to printers use USB to communicate between short range devices.

The USB was first adopted by windows in 1996 and quickly was adapted to many other users. The first version was USB 1.0 which could only communicate as 12 MB per

second. USB 2.0 came out in 2000 Hewitt Packard released it and it could communicated at 480 MB per second. This dominated the industry until they came out with USB 3.0 which could transmit 4.8 GB per-second. It was so fast that it took a year for devices to catch up with the speed. This is currently the fastest USB on the market and has quickly taken over. The USB 3.0 transmits 120000 frames every millisecond from Figure 95. This is the frame that every data packet is built off of. It sets up a distinct set of parameters for each packet.

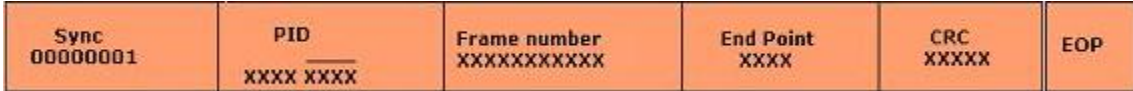

Figure 95: USB 3.0 Frame Structure

5.11.1.1.3 One wire Communication

The last important type of communication between devices is the one wire communication temperature sensor. The DS18B20 Digital Temperature sensor is a single wire digital sensors that communicates via binary synchronous. The communication protocols can use anywhere from 12 – 16 bits 2s compliments to transmit a temperature from 55 – 125°C. The sensor can also communicate via analog output though the digital seems much more stable once the clock signature is programmed correctly. The four basic operations of the 1 wire bus is reset, write 1 bit, write 0 bit read bit. The system is able to create a stable clock cycle of .25 -1 us. Therefore creating a more than stable system with respect to time.

5.11.1.2 Hardware/API Comparison

5.11.1.2.1 GUI

The Graphical User Interface is a major component of this project. The GUI connects all the devices and controls them from a computer. Not only does it control all of the devices it collects and analyzes the data. Therefore this is a huge decisions that could make or break the project in the end. This projects main components are the camera, spectrum analyzer, laser and sensors. All of which are wired into the microprocessor and then fed to the GUI to make it a seamless operation. This presents the point that the most important part of the project is the interaction is the microprocessor with the GUI. The first option considered was MATlab as it is a very powerful tool and all the group members have had experience using the GUI. The second option was LabVIEW as it is a very powerful competitor on the market. From here we will discuss the positives and negative and give a side by side comparison of the two.



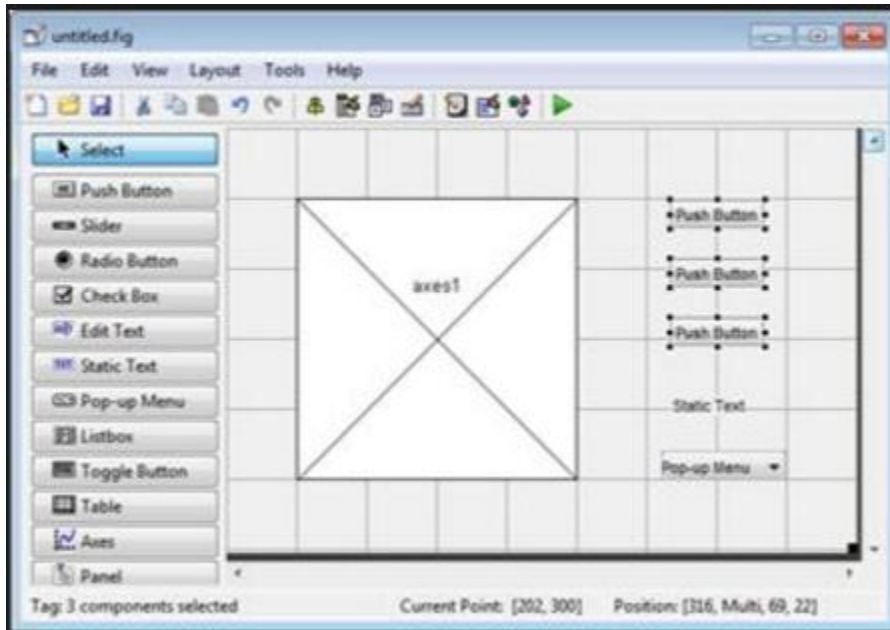

Figure 96: Example of Matlab GUI

The MATLAB GUI will be the core of the whole project without it each system will fail. This means that it is very important to the whole process. Without it no data will be read or collected for many different parts of the interface. Everything will be fed into the Microprocessor and then transmitted via USB to the computer to be displayed on the MATLAB software. The Matlab software is completely custom. As in Figure 96 this shows the basic interface for the creation of the GUI on the left is the list of tools that can be integrated into the GUI. It is a simple drag and drop action. Once placed the button can be right clicked and easily edited and manipulated on multiple levels with respect to assigning code. This is important as each button and sensor and display has to be designed individually.

The system is coded is coded C/C++. The code will be quite extensive for interaction with the Microprocessor to transmit raw data. The main source of raw data will come in from the Spectrum analyzer. This will be pushed into columns in excel and then MATLAB will manipulate the system using the Fourier transforms formulas to take the system to the frequency domain and create a 2 dimensional plot of the spectrum with respect to X and Y spectrum. This is very important to the whole system because it will display whether the results of the spectrum analyzer are correct.

The GUI will also connect and read temperature measurements. This is important as the whole device is temperature controlled. The Microprocessor will relay the UART signal from the DS18B20 Digital Temperature sensor every .25 us. From this the temperature will be constantly displayed on the GUI interface. Also this information will be constantly monitored to interact with a fan that will turn on and off as it hits certain temperature levels. The interface will have information that constantly updates for many different aspects of the project. It will continually update with respect to micro seconds.

### 5.11.1.2.3 LabVIEW

The other option the group looked into extensively was LabVIEW. LabVIEW is a high powered systems that is built directly for creating any type of user friendly environment one could imagine. It can work with almost any software and or hardware. The LabVIEW interface runs off of 4 step process. Front panel, block diagram, controls and indicators and basic functions. All easy to learn and work with from YouTube videos and online forums.

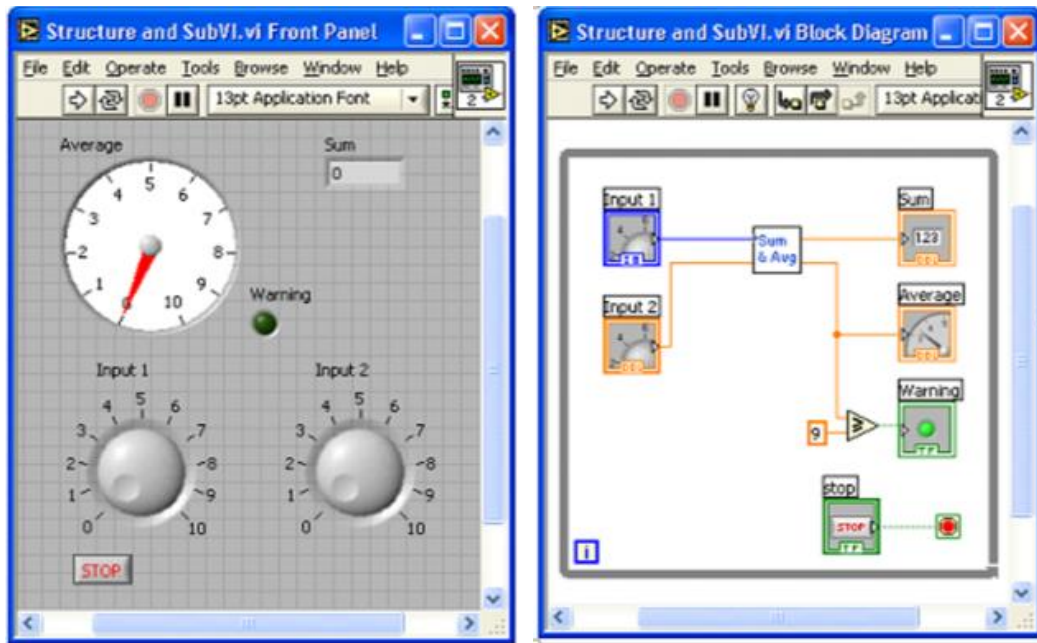

Figure 97: Example of LabVIEW GUI

Every Virtual interface is made up the two basics the Front panel (Figure on the left) and the Block diagram (Figure on the right). The front panel is the canvas that the user will use to design the full interface. This is where the knobs and buttons graphs and so fourth at all shown and called upon by the user. Each button once assigned will correlate directly to a block in the block diagram. The block diagram is the virtual flowchart at which the whole system will connect and the interactions of each component are designed. This is the very core of the system. One can drag and drop any tools that range from loops to calculators to integrators to make the system interact in any direction the user wishes design. Once the user has picked and defined each aspect of the front panel and the flow chart the system can now be fine-tuned by going into the properties of any component and making precision declarations of each parameter. Also through this block diagram any software from any other environment or hardware can be linked to call and collect data at any time. The system is basically limitless it even has design kits that the user can use to design their own tools and add them to the system. There are multiple areas in which you can find and download whole kits that work with different hard and software environments online. Along with new packages there are multiple forums online with people who are paid to help. Also national instruments has built a team to help anyone who is having problems with the software and for a monthly fee there is a

technical support team that will help any user learn and develop the skills necessary as a beginner to be successful with their custom virtual environment. There is no doubt that National Instruments has created a very powerful software that can be continually updated and compete with any virtual environment on the market.

#### 5.11.1.2.4 *Arduino*

The microprocessors all had the above types of communication therefore the choices came down to how much systems were set up with respect to coding languages. The Arduino is an open source platform that's interface use a library of C and C++ functions to call and interact with almost any platform on the market. This is easily one of the broadest used microprocessors across the world. The website has multiple libraries that are easily accessible and have multiple examples for any user to effortlessly teach themselves any coding scheme necessary for individual projects. The computer interface can work directly through USB to call commands through the Arduino. The Arduino can be programmed directly through UART style serial communication to talk to the temperature sensor, power sensor, laser and fan. It will then relay the information back to the GUI where a user will get real time updates of what exactly is happening with the laser and the environment. Below in Table 13 the specs are put into table for easy comparison with other microprocessors.

**Table 13: Arduino UNO Specs**

<b>CPU:</b>	Atmega328
<b>RAM:</b>	2 KB
<b>Storage:</b>	32 KB
<b>GPIO:</b>	14 pins
<b>Ports:</b>	USB

#### 5.11.1.2.5 *Raspberry Pi*

The Raspberry Pi was a very close competitor. Though after extensive research it seemed to be that it was overkill compared to what we needed to do for our project. The Raspberry Pi is actually a micro-computer. It can actually be plugged in and used as a computer though it does not have the extensive reserves for memory and processing power a home or work computer would have. Like the Arduino it is very widely used across the industry. One of the reasons the Pi is so popular is because it has many different language choices for application. It uses the python, C, C++, JAVA, Scratch and ruby for scripting and has many different open source libraries and forums for help online. Also the raspberry pi is designed to be ported to almost any other language making it very accessible to any coder. The newest versions of the raspberry pi have a Gig of ram a 1.2 GHz processor and can connect to almost any type of output from USB to HDMI. The specs are quite impressive as shown in the table below. Below in Table 14 the specs are put into table for easy comparison with other microprocessors.

**Table 14: Raspberry Pi specs**

<b>CPU:</b>	4× ARM Cortex-A53, 1.2GHz
<b>RAM:</b>	1GB LPDDR2 (900 MHz)
<b>Storage:</b>	microSD
<b>GPIO:</b>	40-pin header, populated
<b>Ports:</b>	HDMI, 3.5mm analogue audio-video jack, 4× USB 2.0, Ethernet, Camera Serial Interface (CSI)

*5.11.1.2.6 MSP430*

Another great microcontroller is the MSP430 it uses C as a programming language and can use all the serial communication we need to interact with all our components. This device was used to teach UCF students how to use a micro controller. Also the lower level code MIPS was taught to all the students which gives a lot better understanding of how the microprocessor works. Therefore all the electrical engineers in the group are familiar with how it works and has hands on experience with using the device and the software. This is very important as coding debugging process can be quite extensive and time consuming if errors cannot be found and corrected easily. The MSP430 is widely used across the market but does not have the forum support that some of the other devices have.

This concludes the hardware section of the requirements this shows a great deal of how the hardware is important when interacting with the software for the software design. The communication is very important and has to be reliable along with picking the proper coding languages. Learning a whole new coding language can add a great deal of extra time and the understanding new errors that occur with in different coding schemes is quite important for rapid development. The next section in requirements is the display data. This introduces and shows all the steps for the finding exactly how the display will be coded and interact with the rest of the system. Below, the specs are put into table for easy comparison with other microprocessors.

**Table 15: MSP430 specs**

<b>CPU:</b>	16 Bit RISC
<b>RAM:</b>	512B
<b>Storage:</b>	16 KB
<b>GPIO:</b>	20 PINS
<b>Ports:</b>	I <sup>2</sup> C, USB

#### *5.11.1.3 Display Section*

The Display section of the requirements is largest part of the project that the user will interact with. The user interacting with this will not necessarily be able to write or understand the code on any level. Therefore this needs to be a turnkey solution. This means that no errors or problems should occur. If there are any common user errors that are found that can occur they should be documented with tutorials on how to go about fixing them. The displays main purpose for the user is to communicate with the user how the system is working. That means that this is a safety device in itself as working without the proper protocols set around a laser could lead to harm for the user and anyone nearby. Therefore the following functions are taken very serious in how they are set up and implemented.

##### *5.11.1.3.1 Power Display*

In this section of requirements the display interfaced needs will be discussed. The first thing to address in this section is the setup is the power display. Therefore the software design will include a safety features to continuously monitor the power output to the device at all times and relay back to the GUI. This will be done via one line serial connection from the microcontroller and then fed directly into the computer via USB. The code for this will have to monitor the power from the microcontroller pin to the actual PCB bored via the micro controller. The code must monitor the input/output in real time to initiate and set a flag and send an event to show that a state change has occurred therefore the power is on and the microcontroller must communicate back to the GUI that the event has occurred and the power is enable. This should also do the exact opposite and send a flag or event when the power has cut off to show that it is disable from the microcontroller to the GUI. This showed be in real time and continually update with the current state of the power supply so that the user can monitor the device.

##### *5.11.1.3.2 Fan Display*

In this section of requirements the fan display will be discussed. The fan display needs to show whether the fan is enabled or disable. This is important as the fan needs to be automated with respect to parameters of the temperature sensor to control the temperature inside the hardware box. The two fans need to increase and decrease speeds with respect to the temperature of the box. The hotter the devices runs and heats up the box the higher the speed the fans will go. As the temperature in the box comes back down the sensor will need to continue to send flags with respect to each range to slow down the fans until once again held at the stable desired temperature. This is important as the hardware for the laser needs to be as stable as possible. This adds another safety feature to the device to help make it more stable for laboratory use.

##### *5.11.1.3.3 Temperature Display*

In this section of requirements the Temperature display will be discussed. The temperature display will need to be updated in real time to monitor the temperature of the hardware box. This is very important as it could directly affect the power of the laser. The temperature needs to communicate with microprocessor via one wire communication. The microprocessor will then relay the temperature to the computer GUI to be updated so that user can always see exactly what the temperature is in degrees in Fahrenheit. This

will also be a great safety measure to make sure that the fans are working correctly. If the temperature is not stable the user should be able to tell very quickly.

#### *5.11.1.3.4 The Frequency Vs Time Graph Display*

In this section of requirements the frequency vs time display will be discussed. This is one of two options for connections to the spectrometer. The frequency vs time graph will show the Fourier transform with respect to the data collected from the spectrum analyzer. This is very important as this is the whole reason we are creating device. The toggle button will initialize a process that will take in data from a predefined excel document that is produced by the spectrum analyzer and saved with respect to location for the GUI to call it later. Once the file is identified and open the code will need to pull in the data from predefined spots in the excel document to run a Fourier transform to convert the raw data into a frequency vs time graph. The Fourier transform takes a set of measurements in the X and Y plane and converts them to the frequency verse time domain. The code will need to able to identify all the variable and take the large scale data set into an array from excel and then feed them into the correct formulas for integration.

#### *5.11.1.3.5 CCD Pixel vs Amplitude*

This section of the requirements will discuss the pixel vs time graph with respect to using a CCD. The charge coupled device (CCD) is an array of light pixels that takes in sets of byte words. This sends the array of bytes via serial to the microprocessor which will then relay them to the GUI interface and then translate them to decimal. The bit data packet has to be split into and x and y coordinate system with Y being correlated to intensity and X being correlated to pixel position. This will create a graph that shows an amplitude with respect to position.

#### *5.11.1.3.6 Event Log Display*

In this section of requirements the event log display will be discussed. The event log display gives the user a real time update in if any errors are detected with the code. It feeds them in order of detection directly into the GUI window to help show many different things that could go wrong with the device. This could be from the back end of the code all the way to the high level language of the code. It should show whether the errors are coming from the microprocessor or and the individual device. This is a very important safety feature as using the laser with respect to any code not operating properly could cause damage to different components or the people using the device.

#### *5.11.1.3.7 Camera Picture Display*

In this section of requirements the camera picture display will be discussed. The camera should communicate with Arduino via USB and should sit on top of the eye of the microscope and take pictures upon command from the user. The toggle button should toggle the camera to take pictures directly from the GUI interface and should then display the picture in the GUI. Once the command is toggled it must talk to the microprocessor and tell it to initiate the camera to take a picture and store in a certain place. Then send an event back to the GUI to tell it to call the picture from the predefined file location and display it in the GUI. This is important as it shows the alignment of the object sitting in the microscope for reference of the user. Because this laser is a class ### laser it has to be closed off in a box to operate for protection of the user. Therefore having a camera to

make sure the object is aligned in the correct spot is very important to the user. This is keep from having to open and close the safety box and will keep the user safe.

The requirements for the display with respect to software are quite extensive. But as anyone can see as the requirements for each aspect of the display are identified it then become more obvious on how to put together a plan of action to divide and conquer. This here shows a lot of good information and will help to put together a full picture of what we need for the displays with respect to each step of the software design. The next stage of requirements is controls

#### *5.11.1.4 Controls*

##### *5.11.1.4.1 Initiate Power to Laser*

The power display needs to toggle on and off from the power button in the GUI to show and update in real time if the power is on or off. This is very important as this is a class 3 laser and safety is a priority at all times. If for any reason the laser came on at any time without anyone prepared eye damage could occur or worse. Therefore the software design will include a safety features to continuously monitor the power output to the device at all times and relay back to the GUI. This will be done via one line serial connection from the microcontroller and then fed directly into the computer via USB. The code for this will have to initiate the power from the microcontroller pin to the actual PCB bored via a steady pulse wave modulation.

##### *5.11.1.4.2 Button to Convert Raw Data and Display in Frequency vs Time Graph*

In this section of the requirements the frequency vs time display will be discussed. The frequency vs time graph will show the Fourier transform with respect to the data collected from the spectrum analyzer. This is very important as this is the whole reason we are creating device. The toggle button will initialize a process that will take in data from a predefined excel document that is produced by the spectrum analyze and saved with respect to location for the GUI to call it later. Once the file is identified and opened the code will need to pull in the data from predefined spots in the excel document to run a Fourier transform to convert the raw data into a frequency vs time graph. The Fourier transform takes a set of measurements in the X and Y plane and converts them to the frequency verse time domain. The code will need to able to identify all the variable and take the large scale data set into an array from excel and then feed them into the correct formulas for integration.

##### *5.11.1.5 Back End Code*

In this section we will discuss the requirements with respect to the Back End function that will relay commands between the Microprocessor and the GUI. There are many questions that will need to be answered here. Which device will pull or send and events. Which should be the master or slave? This will define how all the code is written with respect to call commands from the GUI out and set a basis for the whole design layout. Asking all these questions ahead of time and doing the research makes for smooth transitions when doing the design and build after. The microprocessor will also have to communicate individually with each device and send commands back to the GUI. This creates a two way even communication on the back end. The microprocessor will have to have many different subroutines on that back end that will be monitoring the devices connected to the microprocessor.

#### *5.11.1.5.1 Engage fans based on temperature*

In this section we will discuss the back end engaging fans. The fans have 4 different speeds. This code needs to be set to be constantly checking the temperature sensors to monitor the speeds of the fans to keep the hardware box at a consistent temperature. If the system does not stay within the defined temperature parameters the microcontroller should initiate the fans. The microcontroller can be one of the a few optional speeds determined by how much the temperature has deviated from its initial place. The code for the fan will then compare to see which speed has been sent and initiate the fans with the correct speed set from the temperature/speed parameters. The next stage will be to define the parameters for the temperature ranges.

#### *5.11.1.5.2 Collect Data from the CCD*

In this section we will discuss the back end of engaging the CCD with respect to the microprocessor. This is very important as the microprocessor will be set to read the lines in with respect to the CCD. The CCD will need to communicate via the clock to let the microprocessor know that the serial port is enabled and will need to begin to collect data and store in an array. This will then need to communicate with the GUI to let it know that it needs to send data to it and store it in the proper manner. Then the GUI will need to translate the serial imports and do the correct conversions, label them accurately, build a graph and plot the points.

#### *5.11.1.5.3 Door Closed Interrupt*

In this section we will discuss the back end of engaging the door interrupt. The door interrupt is two magnetic devices that when separated sets off an alarm. This device will be used when creating a safety feature for the door. This will have to be a set of loops that are constantly reading the state of the magnetic fields between the magnets. The state will be high or low and the alarm will sound if it changes. This will let the user know if the door is open or not. This will be engaged from the time that any of the features are engaged on the GUI. This will be another level of safety for the whole device to tell anyone safe that is in close proximity.

### 5.11.2 Design Phase

The next stage of the whole project is the design phase. This is where the group went in and took all the requirements found during research and put a blue print together on how to layout the model. Now that we have the requirements we have to connect everything. To connect everything we must set up a plan for how everything will be coded. The main sections discussed are the display data, controls and the back end. These are the same sections discussed previously but we are going into the actual interaction between the software and how the code will be written with respect to the hardware. Also we will pick the software and hardware that we will use for every stage of the system. This is the next phase of design process and it is very important to have done the previous research so that this can be executed on an in depth level.



5.11.2.1.1 Matlab GUI Flowchart

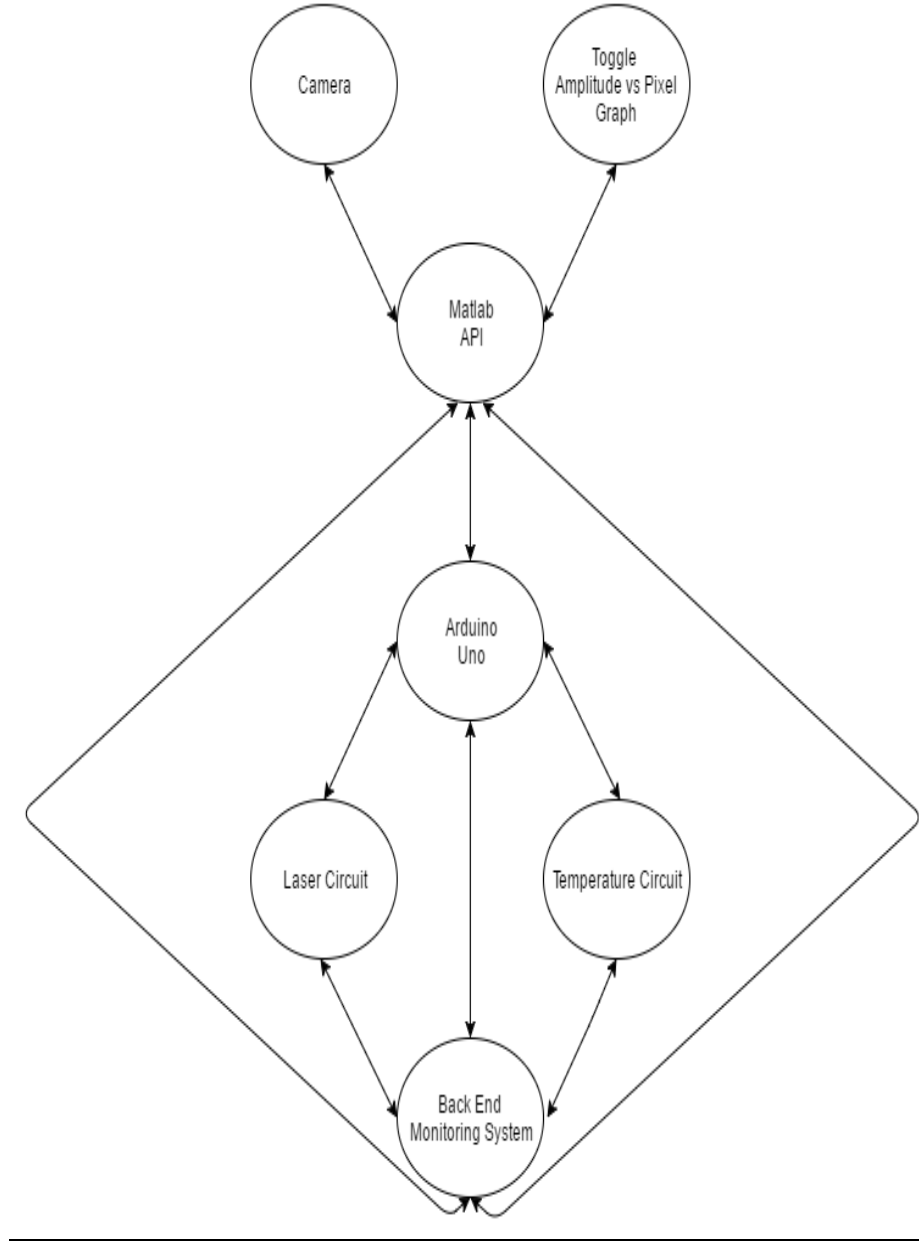

5.11.2.1.2 Final choice Hardware with respect to Software

The first step is to identify which set of hardware is most acceptable within terms of the requirements. One of the largest problems we thought the group would run into from a software perspective is debugging and implementing the code once all the code is written and formatted for the entire project. Other things considered highly important was how large the online support groups were with respect to the help forums. This is crucial as all of engineers were electrical and optical so we had little experience with respect to coding but nothing as extensive as computer engineering. Some other things considered important was how proficient the individual who was coding was with each device or past experience. From the requirements we came to a conclusion that the best fit option

would be to go with the Arduino. The Arduino has a huge online community and with a massive amount of different help programs for anyone using the device. The forums are quite extensive and had a very high rate of help when any individual was reaching out with respect to response time. There is also massive amount of documentation that could be found on each device and code for each components interaction with the Arduino. These are the key essentials we focused on when picking out the Arduino for the groups microprocessor with respect to software. It was an easy decision after seeing the extensive research from the requirements section.

5.11.2.1.3 Application Program Interface

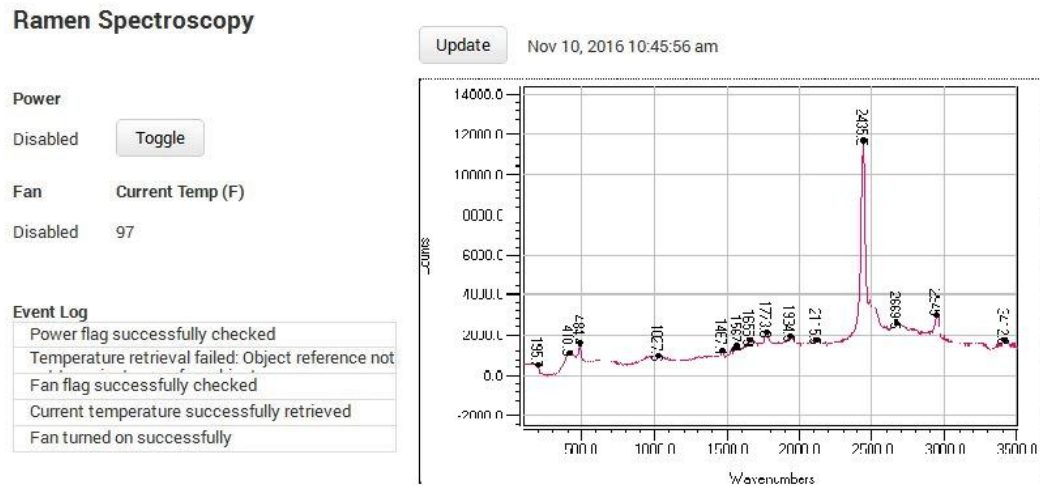

Figure 98: Example of a GUI displaying a Raman spectrum

The two major Application Program Interfaces we considered were discussed heavily in the requirements section. There are many different factors that make them both great competitors. In the figure above we used Justinmind software to create a basic quick layout of what the GUI will look like for reference. Both of these APIs had huge amounts of online support with respect to forums and documentation. The MATLAB forums had a lot more activity on them. However the man power for the online community for MATLAB with respect to Arduino was off the charts. The amount of support for Labview code could not stand up against the support for Matlab with respect to Arduino. Next we researched how they both interacted with Arduino and once again MATLAB stood out on multiple levels. The most significant factor we found was the API libraries that had already been created to directly to interact with most of the Arduino functions. Therefore the API could call a large amount of Arduino functions directly from the GUI interface with very little extra work on the back end. Labview had a much more user friendly interface than MATLAB and are designer had roughly five hundred hours of design work using the Labview interface with respect to design work. This was a huge consideration as there is quite a learning curve when using a new system. The Labview interface was a lot simpler to interact with but it does not have good amount of support with respect to MATLAB. After all the consideration between the two API's the group

decided to go with MATLAB because of how much time would be saved with libraries of functions that could already directly be used with Arduino.

#### 5.11.2.2 *Display Data*

For this section we will discuss the display data and how it will be coded for the design. This is all the front end of the code with direct respect to the MATLAB Arduino communication. The set of libraries for the MATLAB Arduino interface is quite extensive and will play a large roll in the call functions associated with the actual interface. MATLAB has a do it urself GUI interface this is important as it makes it much easier to design each individual button. By typing guide into the command prompt the MATLAB interface opens up an API with multiple options to pick and place into a designated areas where you create a graphical user interface. For this section we will be focused on the edit text box this box will pull data from the Arduino and interact with back end code to update multiple features in real time. This is the basis of all the display data options as they will be used multiple times throughout this section.

##### 5.11.2.2.1 *Power Display*

Power  
Disabled

The power display will be discussed in this section of the display data. The power display will be enable when the power is turned on. When the power button pushed it will initialize the code to send an event to Arduino to enable the power supply for the laser. This Arduino will send a pulse wave modulation to from pin 8 and 5 volt dc voltage from pin 6. After the power is sent out of Arduino ports. There will be a set of loops that will constantly monitor the pin every 100 milliseconds and send an event to MATLAB reader that will be checking every 100 milliseconds for a flag from the Arduino. The display will update every 100 milliseconds to tell the user if the device has lost power to the circuit feeding the laser.

##### 5.11.2.2.2 *Fan Display*

Fan  
Disabled

The fan display will be discussed in this section of the display data. The display will be enabled when the power is turned on. When the power to the temperature control is enable it will send a command to the back end functions to initiate and ongoing loop that will constantly monitor the temperature sensor. The Arduino will send an event to the GUI to flag the display to show that the fan is enabled. This is important because if the temperature is going up and the fan is not enable the user needs to know immediately. Therefore this will will protect the hardware from any overheating damage.

##### 5.11.2.2.3 *Temperature Display*

Current Temp (F)

97

The Temperature display will be discussed in this section of the display data. The display will be enabled when the power is turned on. When the power to the temperature

control is enable it will send a command to the back end functions to initiate and ongoing loop that will constantly monitor the temperature sensor. The Arduino will send an event to the GUI to update the temperature change. This is important because if the temperature is going up and the fan is not enable the user needs to know immediately. Therefore this will protect the hardware from any overheating damage.

#### 5.11.2.2.4 *CCD Pixel vs Amplitude*

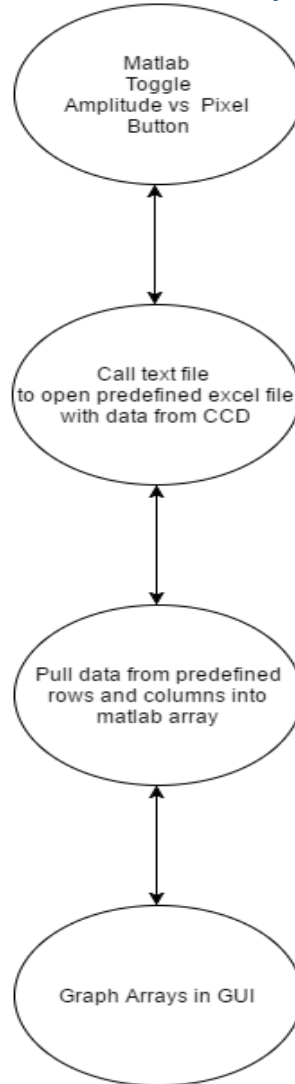

The Frequency Vs Time Graph Display will be discussed in this section of the display data. When the toggle button is hit this will initiate a code that will open the excel document that is named properly for calling and pull the data into mat lab. Once stored in an array in matlab and named properly matlab will the raw data and plot the two sets of data in a display on the graph in the GUI.

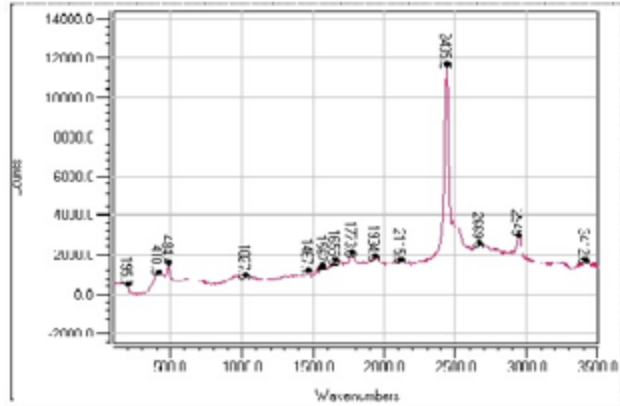

#### 5.11.2.2.5 Event Log Display

Event Log
Power flag successfully checked
Temperature retrieval failed: Object reference not
Fan flag successfully checked
Current temperature successfully retrieved
Fan turned on successfully

The Event Log Display will be discussed in this section of the display data. The event long will be a folder that will constantly be pinged by a loop that watches all the errors in the code. This is important as it gives constant updates of any error that is happening within any part of the code therefore the user knows exactly what is going on in the background code at all times. This will also flag little problems like if the laser door is open it will send a message to the user letting them know that it is open. This will add another level of safety to the whole system incase anything goes wrong to protect the user.

#### 5.11.2.2.6 Camera Picture Display

The Event Log Display will be discussed in this section of the display data. The camera display will send a call command to the camera to take a picture. Then it will pull the newest picture from the files on the camera and update it to the GUI. This is important as this shows the laser and the position that it is hitting the sample as the doors will be close and the sample will not be able to be seen by the naked eye.

#### 5.11.2.3 Controls

For this section we will discuss the controls and how it will be coded for the design. This is all the front end of the code with direct respect to the MATLAB Arduino communication. The set of libraries for the MATLAB Arduino interface is quite extensive and will play a large roll in the call functions associated with the actual interface. The controls were initiate all the commands by the user and set in motion most of the subroutines the back end has. This will initiate all the monitoring for each individual device that it interacting with the Arduino. There are not very many controls but they are very important and powerful.

#### 5.11.2.3.1 *Initiate Power to Laser*

For this section we will discuss the initiate power button with respect to the controls interface. This button initiates the power to the Arduino. This then powers the laser by initiating a pwm to pin 8 and 5 volts dc to the laser circuit. This will also set into motion many of the back end code sub routines. This is the main function that GUI uses there are only two but this turns everything on and gets the whole system ready to work.

#### 5.11.2.3.2 *Button to Convert Raw Data and Display in Frequency vs Time Graph*

Update

Nov 10, 2016 10:45:56 am

For this section we will discuss the Button to Convert Raw Data and Display in Frequency vs Time Graph with respect to the controls interface. This button will call the file that was stored by the Arduino from the CCD. This will then open the file and pull the raw data out into arrays in Matlab and plot them into a graph on the GUI. This is the final process of the whole system. It will give a graph of the spectrum with respect to position of the pixels arrays and the voltage of the signal coming into CCD.

#### 5.11.2.4 *Back End Code*

##### 5.11.2.4.1 *Engage fans based on temperature*

For this section we will discuss the engage fans based on temperature with respect to the back end interface. If the sensor gets above room temperature it will send a flag to the initiate voltage to the pin 3 every 100 milliseconds it will check with the temperature sensor to see if the temperature has changed if the temperature goes up it will increase the fan speed. If the temperature goes down it will decrease the fan speed. These loops will be constantly checking every 100ms to make sure that nothing has changed.

##### 5.11.2.4.2 *Collect Data from the CCD*

For this section we will discuss the Collect Data from the CCD with respect to the back end interface. The Matlab Gui power button will be toggled and power will be enabled. When the power is enable the user the arduino will be constantly monitoring the CCD and communicating via the clock. Once the clock enables the Arduino it pull and store the data on the hard drive of the computer to be saved with a predetermined file name so that GUI can pull it to calculate the graph.

##### 5.11.2.4.3 *Door Closed Interrupt*

For this section we will discuss the Door Closed Interrupt with respect to the back end interface. The closed door interrupt will be initiated when the power button is toggled. This will be initiated and run from the Arduino. There will be a loop that constantly monitors the circuit to see if it is open. If it opens then an event will send a flag to the GUI interface to trigger the display.

5.11.2.4.4 Back End Code Diagram

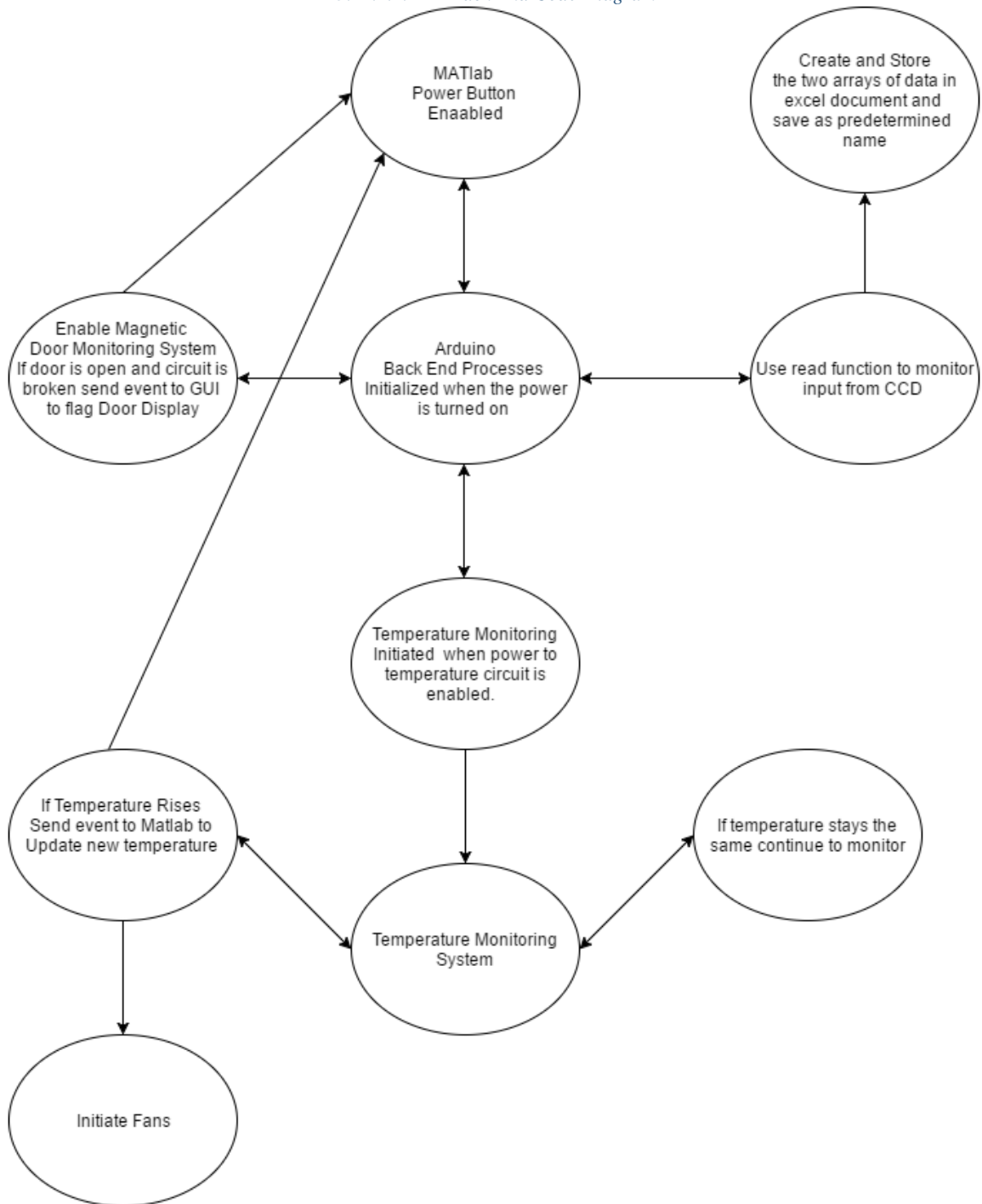

For this section we will discuss the back end code and how it will be coded for the design. The back end code is actually the largest part of the code. This will be made up of many ongoing loops that will monitor updates from every device and updates the displays In the MATLAB GUI. This code will be in charge monitoring all the safety functions that keep the user safe from exposure to laser radiation.

### 5.11.3 Building Phase

In this section we will discuss the building phase of the software. This is the phase we take all the knowledge of the previous sections and put it all together to define that each individual function and how it works. Each function will do a specific task that will be customized to a different section of the design phase. The functions from the MATLAB-Arduino libraries will also be brought and used to help save time. The libraries have been predefined but can be tweaked once downloaded and pulled into the MATLAB reserves. These functions were very helpful as some were already exactly what we need like the read and write functions. They were also useful as we were new at using this code so tracing them and using them to understand the system proved a quick way to get a jump start in coding the system. First we will talk about the data display section and the functions that were created with respect to the flow charts. Each data display links to some part of one of the buttons and updates with respect to time by sending flags to the GUI interface. Next we will discuss the controls and how each button is created. There were very few control buttons but they initiated the whole system which created a lot of subroutines throughout the code. This makes it much more user friendly as the people using the device are chemistry majors and do not know much about how these interfaces interact with each individual device. Each function is set up to call sub functions the MATLAB interface then assigns the function to a button via the preferences. The GUI interface has many different controls that can be tweaked via the preferences from adding functions to the individual figure to setting up arrays, pointers or linking websites to pages. The Figure in the GUI can also be customized with respect to appearance, changing color size and adding pictures to create a personalized UI. The next stage of the system that we will discuss is the back end of the functions. All of the back end functions will be directly called from inside the functions sewn into the GUI buttons. By selecting the functions or buttons the user code can be easily found and edited if any new updates need to be added later. The GUI can also be locked that so no one can stumble into and mess up the code when trying to develop changes with respect to new additions to the system. This will make the source code secure as that is a common problem in labs these days. This section was the most difficult to create because it takes such an in-depth knowledge of what is going on with respect to the system as a whole and the lower levels of how the code actually interacts with the hardware. The code is all made in individual batch files and called individually by the main system. This is how C++ works it uses the basics of C for the actual language and then has several object oriented features that work to manage memory better and RAM with respect to parallel processing. This is quite efficient as we have many processes running in parallel on the Arduino. For this project we all knew a basis of C but were not very familiar with C++ we have all done small projects in the past that used C++ so we researched books that were the best for beginners and found *Jumping into C++*. This was a good starting point for learning how to build and structure the environments. This also was very helpful understanding how the compiler worked with respect to the lower level code and the IDEs.

#### 5.11.3.1 Display Data

This section will discuss the individual functions used to interact with each display and exactly how the code will work with respect to every step of the process. This gives a final layout of the code in great detail. This is the final stage of development for



the actual code that will be used for the interaction between the MATLAB GUI and the Arduino.

#### *5.11.3.1.1 Power Display*

In this section we will discuss in detail exactly how the code will work with respect to the functions needed to code the power display. The function `readDigitalPin(a,Pin)` will be in the main executable code that will be initiated when the enable button is toggled. The function will be set in a loop that is called every hundred milliseconds. After it is called and the value is stored in a variable “N” the variable will be compared to the previous value stored in `N+1`. If the value is the same the code will store `N` in `N+1` if the code is not the same it will send a flag to the power enabled display to change display to disabled. Then it will send a flag to the Arduino to cut power to pins 5 and 8 to be disabled.

#### *5.11.3.1.2 Fan Display*

In this section we will discuss in detail exactly how the code will work with respect to the functions needed to code the fan display. The back end executable code will be enable when the power button is toggled on the GUI interface. In the executable code there will be an if/then statement that will be right after the temperature Arrays are compared. Once the arrays are compared if the temperature in `tempArray` is greater than `temp` in `Array1`. Then function `enablefandisplay()` will be enabled which will send an event to Matlab to set the flag high for the display which will correlate to enabled and the display will change.

#### *5.11.3.1.3 Temperature Display*

In this section we will discuss in detail exactly how the code will work with respect to the functions needed to code the temperature display. The back end executable code will be enable when the power button is toggled on the GUI interface. In the executable code there will be a loop that pulls in updated values of the temperature from the one wire connection and stores it in an array called `tempArray`. This Array will be compared to `Array1` using the `(stringtempArray1.equals(tempArray))`. If the arrays are the same the code will be set to repeat the loop in 100 milliseconds. If the array is different than the value of the array will be sent to the display function by storing the value in the array that the display that the function is set to update from every 100 milliseconds.

#### *5.11.3.1.4 CCD Pixel vs Amplitude*

In this section we will discuss in detail exactly how the code will work with respect to the functions needed to code the CCD Pixel vs Amplitude. The frequency vs time graph will be generated by toggling the button for generating the graph. This will enable Matlab to pull the data from an excel worksheet using the function `xlsread(filename, xlrage)` and set it equal to an array. Then plot the graph using `plot(x,y)`. This will generate the graph in the GUI.

#### *5.11.3.1.5 Event Log Display*

In this section we will discuss in detail exactly how the code will work with respect to the functions needed to code the Event Log Display. The functions will be in the main executable code that is enable when the power button is toggled. The executable

code will have a function `guidedata(object_handle,data)` and set it equal to the location of the of the event holder in the GUI.

#### *5.11.3.1.6 Camera Picture Display*

In this section we will discuss in detail exactly how the code will work with respect to the functions needed to code the Camera Picture Display. The button to take a picture will be toggled and the camera will activate the `getfilefunc(//Filepath)` the file path must already be predefined. Then it will use the `imshow(//filepath)` to post the picture the GUI.

#### *5.11.3.1.7 Initiate Power to Laser*

In this section we will discuss in detail exactly how the code will work with respect to the functions needed to code the Initiate Power to Laser. The executable code will be initiated, the code will use the function `digitalwrite(a,Pin)` to initiate power to the dc part of the circuit. The function `analogwrite(a,Pin)` will initiate analog signal to the correct pin for the analog part of the circuit. This will also initiate the main executable code for the whole system.

#### *5.11.3.2 Back End*

For the build section of the back end we discuss how each individual function is used from the Matlab/Arduino libraries to monitor the safety procedures of the GUI. The functions are all in the executable code and enabled from the power button being toggled. These functions all directly communicate to each individual device and matlab. The main functions that will be used are functions that will initialize power to the Arduino pins and send events to Matlab to change displays or cut power. The code will be made up of mostly if then statements and call functions.

##### *5.11.3.2.1 Engage Fans Based on Temperature*

In this section we will discuss in detail exactly how the code will work with respect to the functions needed to code the Engage Fans Based on Temperature. The back end executable code will be enable when the power button is toggled on the GUI interface. In the executable code there will be a loop that pulls in updated values of the temperature from the one wire connection and stores it in an array called `tempArray`. This array will then be compared with room temperature by using the command `(stringtempArray.equals(tempArray))`. Wrap this command in an if then statement. If the two arrays match then the loop will repeat in 100 milliseconds. If they don't the function `digitalwrite(a,Pin)` will enable power to the fans to initiate high and to jump out of loop. Outside the loop there will be the same code but the code will compare the two arrays and if they are the same it will repeat the loop in 100 milliseconds and if they don't it will jump back into the beginning of the previous loop and use the `digitalwrite(a,Pin)` function to disable power to the fan.

##### *5.11.3.2.2 Collect Data from the CCD*

In this section we will discuss in detail exactly how the code will work with respect to the functions needed to code Collect Data from CCD. The communication between the Arduino and CCD will be enabled by the clock. When the clock pin goes high the Arduino will enable a read in a serial string and store it in an array from the command `serial.readString(location of array)`. Once the data is collected the Arduino will send the data to an excel document that will be called by the function `callPLX()`. This

will initialize a plugin that will pull the data from the array and store it in matlab columns.

#### *5.11.3.2.3 Door Closed Interrupt*

In this section we will discuss in detail exactly how the code will work with respect to the functions needed to code Door Closed Interrupt. The code will be enabled when the power button is toggled. The door sensor will be enabled by a `digitalwrite(a, pin)`. The negative side of the door will be plugged into pin 2 and the Arduino will monitor it with the `digitalread(a,pin)` function. This will check to see if the pin is high at all times and if it goes low then the code will exit the loop and initialize the command `digitalwrite(a,Pin)` to cut the power. Also this will enable an event to be sent to the event log to warn the user that laser has been turned off because the door is open.

#### 5.11.4 Testing

In this section we will discuss the plan for all testing procedures. This is where we decide what tests to run on the system to try and find errors. This is the most important part of coding. If the coder doesn't break his system in every way possible than it will leave room for errors after release. For every error it slows down the user because the program has to be debugged and re-implemented. This can make or break a product in the long term multiple releases can be quite extensive and time consuming. This takes up man hours on both ends from the user and the developer. Therefore everyone is losing money. Because of this one must pay particular attention to detail with in respect to how the code is written all levels. Some coders have been known to write out all the ways they can test the code before they even write the code. This makes sense in a logical manner as if you can write out every way possible to break the code before you write the code. The designer can work from the beginning to side step the common errors found. Therefore eliminating problems from the get go. We will discuss all three major sections discussed in each phase of the design process previously Data Display, Controls and the back End Architecture.

##### *5.11.4.1 Types of Tests*

There are many types of tests that a designer can use to make sure the code is work properly. One of the most basic tests is the unit test the unit test it works to test little specific parts of the code or a unit of the code. This is important as verification of each snippet of code as you go can save a lot of time instead of trying to go back and track to go back and track littler errors later can be quite tedious. The next stage is integration tests these test work to show that all separate parts of your code work together. Acceptance tests show the management and users the functionality of the code. The last is regression testing which re-runs the unit tests to make sure they work properly after the integration tests have been finished.

## 6 PROJECT PROTOTYPE CONSTRUCTION

### 6.1 INTEGRATED SCHEMATIC

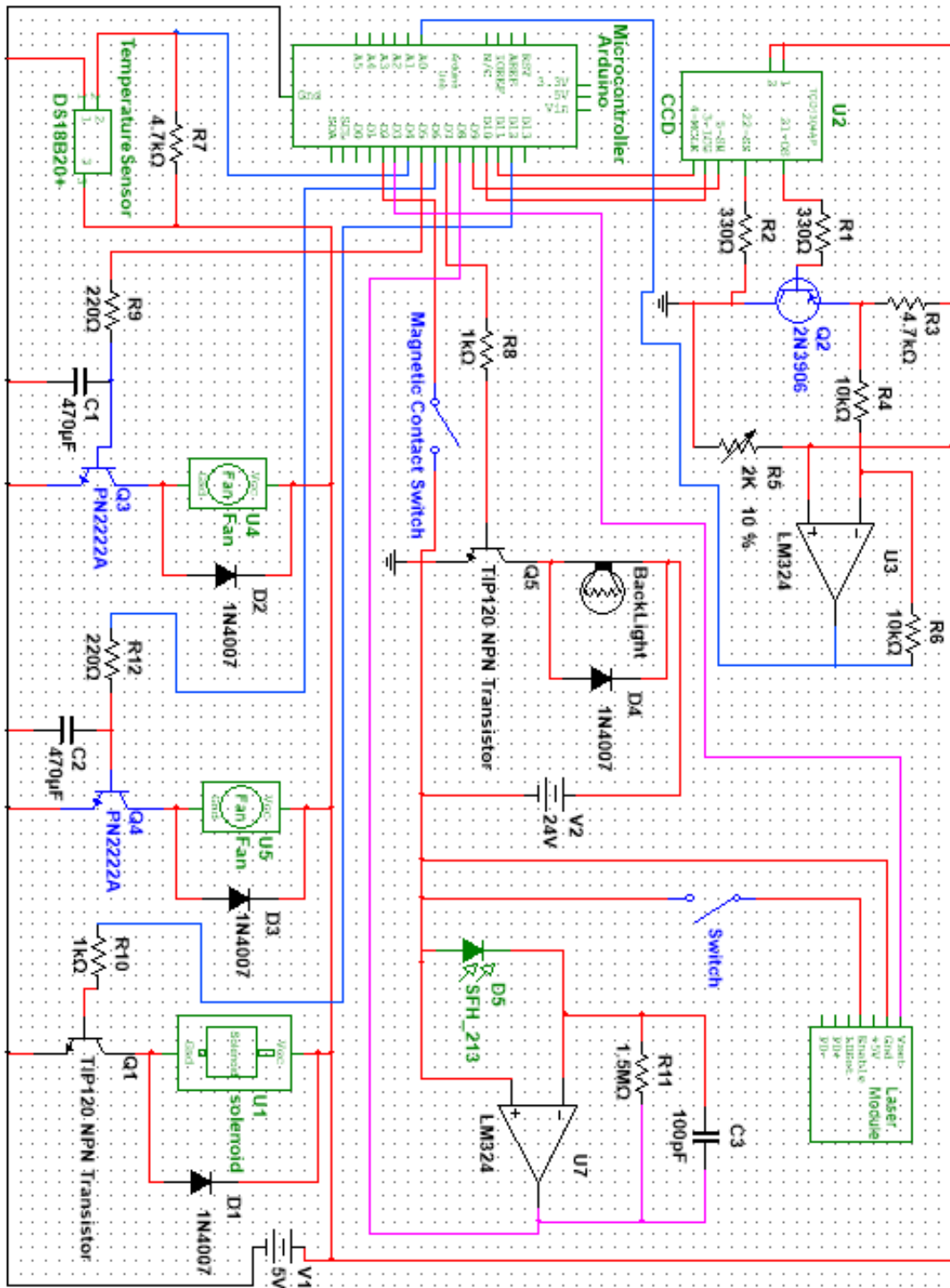

## 6.2 BREADBOARD TESTING

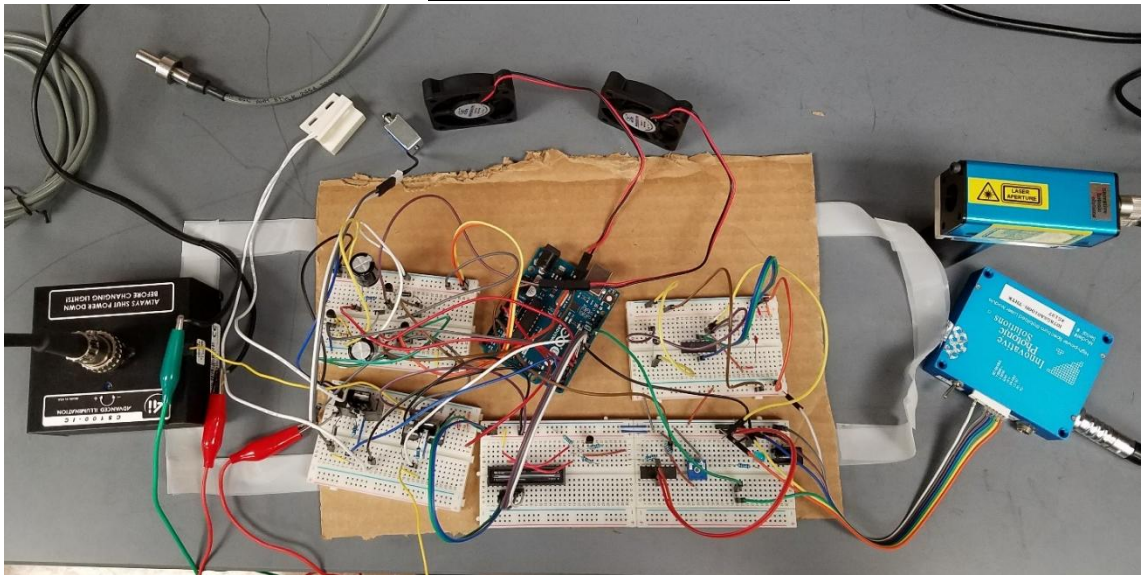

Breadboard Test with all devices

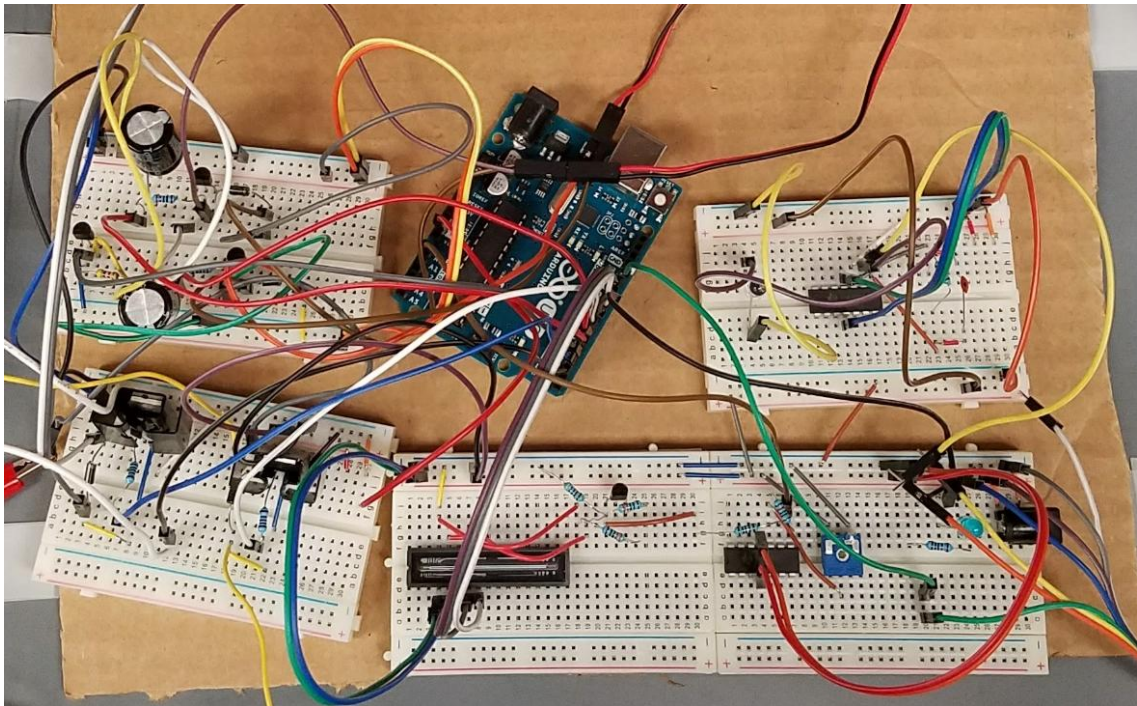

Breadboard Testing showing breadboard circuits only

## 7 PROJECT PROTOTYPE TESTING PLAN

### 7.1 HARDWARE TEST ENVIRONMENT

Both the design and building of the project environment consists of working in the National Center of Forensic Science (NCFS) building located in Dr. Matthew Baudelet personal undergraduate laboratory where photonic experiments are hold. In this lab, the electrical breadboard testing has been done as well as any optical testing as well.

The actual testing procedure which has been discussed in previous sections in terms of electronics is to basically do the research on the parts. Once parts is ordered and have arrived, breadboard testing will occur. This was done in phases where each section was given its own breadboard and was testing individually. For example, the temperature control was done on a a single breadboard that consisted of 2 fans with their respective components and the temperature sensor. Another section like laser power control was done on its own breadboard. This was done for every single section. Finally, all breadboards were connected together and power was jumped to all breadboards. Any output pins from each breadboard were connected to the Arduino.

### 7.2 HARDWARE SPECIFIC TESTING

#### 7.2.1 Excitation System Testing

This test is to see if a Raman signal can be created using the 785 nm laser and the two RBGs, the following procedure is used. First the laser beam will be incident on the two RBGs to narrow the line width of the laser. The lab currently has an objective lens with a numerical aperture of 0.4 and a magnification of 20. After the laser beam is aligned to reflect off the two RBGs, it can be aligned to the objective lens so that focusing can occur on a sample. After focusing the laser beam onto the sample, a Raman signal is created. The Raman signal will then follow the same path that the laser beam traveled, but backwards. In other words, the Raman signal will pass through the 20 X objective and be collimated onto RBG 2. RBG 2 will then transmit the Raman signal. If another objective or focusing lens is placed behind RBG 2, then the Raman signal being transmitted through RBG 2 can be focused. After the focusing lens will be a fiber optic cable that is attached to a small ocean optics spectrometer (QE65000) that is in the lab. The focusing optic will focus the Raman signal unto the fiber so that the ocean optics spectrometer can detect and display a spectrum. This test will help to see if the laser and two RBGs can create a Raman excitation. After this test, the laser can be injected into the microscope using the periscope, and the spectrometer built in this project can be used to collect a Raman spectrum.

Tests can be performed using the RBGs to see its spectral filtering capabilities. For instance, using the ocean optics spectrometer, the spectrum of the laser can be taken and the FWHM of the laser peak can be calculated. Then after reflecting the laser off the RBGs and optimizing the alignment, a spectrum of the laser spectral profile can be taken to calculated the FWHM. Comparing the FWHM of the laser spectral profile before and after the laser beam reflects off the RBGs will provide how well the alignment and RBGs are in filtering the laser line.

To test the filtering capabilities of the notch filter, a spectrum of the laser spectral profile can be taken before and after the laser beam reflects off the notch filter using the

ocean optics spectrometer. If the spectral profile of the laser beam is taken after it reflects off the notch filter and it shows a spectral line with a low intensity, then the notch filter is effectively weakening the laser signal. Three notch filters are used in this project. Therefore, a spectral profile of the laser beam can be taken after the laser beam reflects off the three notch filters. If the spectral profile shows a laser line that is close to zero in intensity, then the notch filter can effectively filter out the laser line.

#### 7.2.2 Detector Calibration

The purpose of the spectrometer is to be able to display the intensity of each wavelength of light that is created by the Raman shifting. In order to do this, the detector must be calibrated so that it accurately shows the height of each peak. The detector cannot be assumed to be accurate without calibration because the optics inside the spectrometer may not reflect or transmit lights of varying wavelengths the same way, which can result in errors in detection.

The simplest way to calibrate the detector is to use a broadband source that has a known spectrum. In this case, the source only needs to fully cover the spectral range of the detector, which is approximately 770 nm to 800 nm. Because this is such a small range, any light source that emits near this range will probably be an adequate source. Most likely, an LED will be used.

First, the spectrum of the LED must be measured using an already calibrated spectrometer. A spectrometer has already been provided by the sponsor for the project. Once the spectrum of the LED is known, the LED will be coupled into the Raman system so that the light emitted from the LED passes through all of the optics of the spectrometer. This is most easily achieved by having it placed in front of the microscope objective. The detector inside the Raman microscope then measures the spectrum that it sees.

The final step in calibration is to make the second spectrometer match the first one. This is done by taking each data point in the second spectrum and multiplying it by a coefficient (usually greater than one) so that it matches the equivalent data point on the first spectrum. Each coefficient is stored by the computer as the calibration array. This calibration array is then applied to every spectrum obtained by the detector. This will result in a spectrum that accurately shows the height of every signal.

### 7.3 SOFTWARE SPECIFIC TESTING

There are many types of tests that a designer can use to make sure the code is working properly. One of the most basic tests is the unit test the unit test works to test little specific parts of the code or a unit of the code. This is important as verification of each snippet of code as you go can save a lot of time instead of trying to go back and track to go back and track littler errors later can be quite tedious. The next stage is integration tests these test work to show that all separate parts of your code work together. Acceptance tests show the management and users the functionality of the code. The last is regression testing which re-runs the unit tests to make sure they work properly after the integration tests have been finished.

There are many things that can be tested. Possible cases, systems and how they gets turned off. If things get turned off while still running. If the machine gets turned off while still transmitting how does this affect the code. Click multiple buttons without waiting for

data to come back from first. Closing the program before waiting for data to come back. Double click a button without waiting for response. How to code it differently with respect to not breaking. These are all components that can be tested.

There are many components to testing. A big part of testing is just creating unit tests. One can do this by creating message text boxes and implementing them into the code to show that the code is producing the right data in every variable or array. This will be a significant factor in the testing process as it will allow the group to test every step of the code along the way. To do this we will create message boxes that will be embedded in the code after every variable and array. It will call the individual variable or array and display them in text files. Then the designer can go back through and check to make sure every step of the code matched the data it was supposed. If done correctly one does it as they are writing the code to check the code as they build it. Then comment out the message box so at any point if they want to go back and check the problem they just have to remove the comment markers. This makes for a simple way to go back and check exactly what everything does at any time.

The next level of testing will be for the communication of the devices with the Arduino. The Arduino will be talking to multiple devices at once so testing that it can handle doing roughly five things at once will be important. The Arduino has very powerful CPU but the more stress put on anything the more chances it has to break. So we will run the code repeatedly and see how it works with all the parallel processing occurring. Common problems are over heating or bits being missed creating flags that build and disrupt the flow of the whole code. Control the bit rates can help this a little. As we run the software we will work to edit the speeds of things and change the order of the executable code with delays so that the code is working as efficiently as possible. This is crucial as the users who will be using the code will not have any idea what is going on in the background. This is why we created the even log.

The event log will display any problems that the user will come across that we have replicated. There will be a look up for the user to look up the events and be able to identify what is going wrong with the system. This is be very simple and to the point. Simple things like when the door alarm goes off it will instruct the user that the door magnetics needs to be flush with the door completely closed for safety purpose. Then it will instruct the user that the power has been disconnected to the laser. The door will need to be closed before the power to laser will be able to be re-enabled. This will not however show the user how to edit the code. The code will be locked so that only indivial with the property authority will be able to access and edit it. This is because there of individuals who think they know what they are doing but don't and can end up doing a lot more damage than is good in the long term.



## 8 ADMINISTRATIVE CONTENT

### 8.1 MILESTONE DISCUSSION

#### September

September was the beginning of senior design one it was the time to branch out and look for group members. There were many different groups with many different projects already formed looking for new members. Each group courted many individuals and spent a lot of time talking and discussing different options to see if each individual would fit perfectly with the group depending on their skills and goals. The ramen spectrography group was already made up three member 2 photonics and 1 electrical engineer. At this time they reached out and found a 2<sup>nd</sup> electrical engineer with a background in GUIs. After much discussion of the project everyone agreed on that the group wanted to work to redesign a cheaper version of a Ramen spectrometry set up. This device would include lasers, spectrometer, temperature sensors a cooling system and a GUI system to control it all.

#### October

The project had been defined and the ideas had been starting to accumulate on how this was going to work but there was a lot of grey areas so next we meet with the professor. Professor Matt Baudelet has a lot of experience in ramen spectrography and was willing to fund the whole project as there are no cheap version of the equipment on the market. It was then defined that we would meet every Friday afternoon to discuss the project and begin putting together a set of parameters and parts list for the future design and research. The group then began research and started the initial 10 page outline overview of the whole project. Everyone's roles and expectations were assigned. The two electrical engineers would work on the electronic circuits to control the power to the laser, fan, spectrometer and coding to develop a GUI that would integrate the whole system. The two photonics engineers broke up the laser work into spectrometer and laser alignment with respect to the CCD amongst each other.

#### November

In November the research was quite extensive everyone broke up into groups came back and showed what they had found and how they could integrate their research in the big picture. Each part was designed to be integrated into an Arduino configuration that could be controlled via MATLAB. Since the funding was now in line we ordered parts and started work using the laser and spectrometer. The circuits were designed for the each set of individual components and the circuits were tested to make sure that all the correct values. The GUI started to gain legs as the basics of the layout were designed and the coding started and layout was replicated in MATLAB. The basic designs for the printed circuit boards were created and tested.

#### December

In December we spent a lot of time working on finalizing the research and working together in two small groups. The EEs broke up into groups and the optics majors into their own group. The optics worked hard to finalize the math and research for writing there senior design paper. The EEs worked hard to design the software designs

along with the hardware designs for the PCB. This was a crunch time because there was so much to be done with respect to the senior design paper. The Optics engineers spent a lot of time finishing design work with respect to the mirror angles and CCD. The theory researched early on helped speed up the process. The circuits have been designed so the printed circuit board should be finished and in by the end of December or January.

### **January**

In January all the parts should be in with and accounted for. The optics parts will begin to be assembled and alignment will be done with respect to the CCD. All circuit components will be tested to make sure that they work correctly. The PCB board will be tested and the code implemented for the first assembly. This will be the time for all trial and error to see if we need to remake the PCB. The optics will be set up and the VGBS will need to be aligned with the laser. This is important as the optics are very sensitive and alignment is crucial. The alignment will not be a quick process. It will be a long process of trial and error but without this step done correctly we cannot move forward. This month will be a long process of trouble shooting and trying to find every problem possible across the board.

### **February**

The Laser should be aligned along with the VBG. This will now be the time for all other optical components to be aligned with respect to the math theory done previously from the research. Everything has to be exact and there is no chance to buy new parts for the optics as they are very expensive if anything is damaged so everything must be treated like a new born baby. The CCD must be set up and tested. The PCB will need to be fixed if there is anything wrong with it and redesigned and reordered. Code testing will begin extensively at this time on the old pcb if any parts of it are working. Also the GUI should be done and be ready to be tested. The new pcb should be back before the month is over and retested. The PCB will be tested extensively with the new code and we will try to break the new code and in any way possible.

### **March**

March we will be checking that everything is perfect and that trouble shooting more errors. The optics team will be testing the detector to make sure it is operating correctly with the code to create the desired results for the Amplitude vs Pixel graph. This will be a time for working on developing the code to get it to exactly the way we want. The code will need to be completed and put together to flow and tested extensively. The back end code will have to be tested to make sure it is working correctly in the background with no errors. All common errors that are the users fault will need to be documented and some type of guideline will need to be built to show the user what they are doing wrong. The spectrometer should be complete by this point. The testing should begin to start making sure that the GUI can communicate with it and can manipulate the data produced by it correctly to create the graph.

### **April**

This month should be the final testing of everything. Everything should work without problem by this point. This will be the time to build the box for all the hardware

and spectrometer. This will be protect the equipment and hardware and the fans will be implemented with the proper code to keep the system from overheating. The door alarm will be installed and tested with respect to the back end code. The optics team will now have to secure everything to the boards in the box and make sure that they cannot move. They will also have to come up with a plan to assess and be able to realign the optics after the move because it could take hours or days to realign all the optics. This is a big deal as the final viewing has to be in the engineering building.

**May**

This will be the end of everything in a perfect world we will be hanging out ready to go to show everything off. However we will probably being doing last minute tweaks with everything. Recording everything working and showing that each stage of the device works. Therefore if anything goes wrong with respect to the actually showing we will have proof that each individual part works. The paper will have to be fixed and edited to make up for all the changes that occur throughout the actual design build. Everything will need to be double and triple checked. But in reality we will probably be running around like chickens with our heads cut off trying to do all the last minute things we let slide. Another options if anything breaks from the optics to the pcb trying to last minute get new ones and re install and be prepared for the deadline.

8.2 BUDGET AND FINANCE DISCUSSIONS

**Electrical Budget**

<b>Number of Parts</b>	<b>Name of part</b>	<b>Price</b>
2	Arduino Uno	\$49.90
1	Diode Kit	\$5.99
1	5V, 2A Power Supply	\$3.95
1	Transistor Kit	\$19.99
1	Capacitor Kit	\$19.99
1	Resistor Kit	\$10.99
3	5V DC Fan	\$23.97
1	Molex Circuit	\$1.14
1	Mating Connector	\$.76
3	CCD Connector	\$10.50
3	DS18B20 Temp Sensor	\$11.85
3	BC 547 Transistor	\$1.02
3	N channel Mosfet	\$3.33
3	LMF 324 OP AMP	\$1.74
3	Photo Diode	\$2.52
3	Mini Push-Pull Solenoid	\$9.90
3	Heatsink	\$2.50
<b>Total Cost</b>		<b>\$180.04</b>

### Optics Budget

	Part	Manufacturer	Price
Notch Filter	Notch Filter	OptiGrate	N/A
Magnifier	12.7mm D x 15mm F concave lens	Thorlabs	\$37.03
	25.4mm D x 75mm F convex lens	Thorlabs	\$32.60
	12.7mm D cage lens mount	Thorlabs	\$16.00
	25.4 mm D cage lens mount/Cage adapter	Thorlabs	\$34.70
	Cage rods (4 pack)	Thorlabs	\$25.37
Grating	1200 lines/mm Reflective Diffraction Grating (750 nm blazed) 12.7x12.7 mm	Thorlabs	\$64.40
	Grating Mount	Thorlabs	\$65.90
Focusing Mirror	3in D x 30in F concave mirror (coated)	Edmund Optics	\$295.00
	3in D Mirror Mount	Thorlabs	\$185.00
Detector	Three TCD1304AP CCD detectors	Toshiba	\$10.50
Periscope	Two 1" Broadband Dielectric mirror	Thorlabs	\$150.20
Microscope	749 nm Single Edge Short Pass dichroic beamsplitter	Semrock	\$335
Photodiode	.5" Broadband Window, uncoated	Thorlabs	\$50
<b>Total</b>			\$1301.7

## 9 Project Summary and Conclusions

This project involves building a Raman attachment for a microscope so that Raman spectroscopy can be performed. The Raman attachment includes an excitation system and a spectrometer system. The excitation system includes a 785 nm laser that is aligned toward two Reflective Bragg Gratings (RGB) so that the FWHM of the laser spectral profile is narrowed down. The narrowed laser line is then guided toward the hole in the microscope using a periscope. The microscope focuses the laser beam using an objective lens onto a sample to create the Raman excitation. The Raman excitation is collimated out of the object lens and out of the microscope and into a spectrometer. The spectrometer contains notch filters, a beam expander, grating, focusing mirror, and a CCD detector. The goal is to obtain a Raman spectrum on a specific spot on a sample with a spectral window of approximately  $\pm 200 \text{ cm}^{-1}$  and a resolution of less than  $5 \text{ cm}^{-1}$ . Electronics is used to vary the laser power, measure laser power, block the laser beam for safety reasons, turn off the backing light during spectral acquisition, measure temperature of the system and create air flow. Software has to be applied to create an easy to use graphic user interface (GUI). The GUI must include a camera image of where the laser spot is on the sample, a measurement of temperature and laser power, a display of a Raman spectrum, a button to vary laser power and turn off the backing light. Finally, the Raman system must be enclosed in a box for safety reasons.

In terms of testing done for electronics, the fans and laser power can be controlled by pulse width modulation. Magnetic contact switches are also tested with a push-pull solenoid to block the laser beam. Circuits for temperature sensors are built to measure temperature and is tested to work. Furthermore, circuits for the photodiode and CCD are built and can provide an output signal that show that the circuit has been well connected. Laser injection into the microscope has been performed using a 532 nm laser because the beam splitter inside the microscope reflects at 532 nm. The laser was aligned to the microscope objective until the full intensity of the laser beam was incident on a sample. The camera image of the sample was then taken and a laser spot was shown to irradiate a certain region of the sample. This test shows that laser injection into the microscope is possible and the camera can image a laser spot on a certain location of the sample. A transmission spectrum of the beam splitter in the microscope was taken to see if it can reflect at 785 nm because this is the wavelength of the laser that will be used in this project. The transmission spectrum shows that the current beam splitter is not suitable for this project and a new beam splitter will have to be purchased. In terms of the software side of the project, an early design for the GUI has been made so that the goals for what needs to be coded are set. With the tests and designs done, this project can be completed within the time frame provided in senior design 2.

## 10 References

### Electronics Links

<http://www.cui.com/catalog/resource/power-supply-safety-standards-agencies-and-marks.pdf>

[http://www.wikiwand.com/en/Transimpedance\\_amplifier](http://www.wikiwand.com/en/Transimpedance_amplifier)

<http://electronics.stackexchange.com/questions/192224/photodiode-amplifier-circuit>

<https://www.csee.umbc.edu/courses/undergraduate/CMSC391/summer04/burt/lectures/arch/architectures.html>

[http://www.ti.com/lscds/ti/microcontrollers\\_16-bit\\_32-bit/msp/getting-started.page](http://www.ti.com/lscds/ti/microcontrollers_16-bit_32-bit/msp/getting-started.page)

<https://www.arm.com/products/processors/classic/arm11/arm1176.php>

<https://blog.adafruit.com/2012/05/25/handy-arduino-r3-pinout-diagram/>

<https://www.arduino.cc/en/Tutorial/PWM>

<http://www.learningaboutelectronics.com/Articles/TMP36-temperature-sensor-circuit.php>

<https://arduino-info.wikispaces.com/Brick-Temperature-DS18B20>

<http://www.tweaking4all.com/hardware/arduino/arduino-ds18b20-temperature-sensor/>

<http://davidallmon.com/pages/ad7667-spectrograph>

<http://projectsdunia.blogspot.in/2015/03/arduino-based-automatic-temperature-fan.html>

<http://arduino-for-beginners.blogspot.com/2011/03/controlling-12v-dc-motorfan-with.html>

<http://circuitdigest.com/microcontroller-projects/automatic-temperature-controlled-fan-project>

<http://bildr.org/2012/03/rfp30n06le-arduino/>

<http://www.ardumotive.com/magnetic-sw-en.html>

<https://teachmetomake.wordpress.com/how-to-use-a-transistor-as-a-switch/>

### Optics Links

<http://pdfserv.maximintegrated.com/en/an/AN126.pdf>

<https://www.raspberrypi.org/magpi/raspberry-pi-3-specs-benchmarks/>

<https://www.arduino.cc/en/Reference/Libraries>

<http://www.digikey.com/product-detail/en/maxim-integrated/DS18B20/DS18B20-ND/420071?WT.srch=1>

<https://www.youtube.com/watch?v=BcWixZcZ6JY>

<http://archive.cnx.org/contents/aeec99e1-5caf-4ca2-a245-67f8c457056d@5/lab-1-introduction-to-labview>

<http://www.eeherald.com/section/design-guide/esmod14.html>

<http://davidallmon.com/pages/ccd-transmission-spectrograph>

<http://www.integralist.co.uk/posts/guide-to-js-testing.html>

<https://www.mathworks.com/help/supportpkg/arduino/ug/use-serial-communications-with-arduino-hardware.html>

<http://www.integralist.co.uk/posts/guide-to-js-testing.html>

[http://www.optigrate.com/BragGrate\\_Bandpass.html](http://www.optigrate.com/BragGrate_Bandpass.html)

<http://www.horiba.com/us/en/scientific/products/raman-spectroscopy/raman-academy/raman-faqs/what-laser-wavelengths-are-used-for-raman-spectroscopy/>

<http://www.horiba.com/us/en/scientific/products/raman-spectroscopy/raman-imaging/>

<http://www.optigrate.com/technology.html>

<http://bwtek.com/wp-content/uploads/2015/07/raman-laser-selection-application-note.pdf>

<http://www.ondax.com/>

<http://www.renishaw.com/en/products--32083>

<https://www.thermofisher.com/order/catalog/product/IQLAADGABFFAHCMAPB>

### **Software Links**

<http://pdfserv.maximintegrated.com/en/an/AN126.pdf>

<https://www.raspberrypi.org/magpi/raspberry-pi-3-specs-benchmarks/>

<https://www.arduino.cc/en/Reference/Libraries>

<http://www.digikey.com/product-detail/en/maxim-integrated/DS18B20/DS18B20-ND/420071?WT.srch=1>

<https://www.youtube.com/watch?v=BcWixZcZ6JY>

<http://archive.cnx.org/contents/aeec99e1-5caf-4ca2-a245-67f8c457056d@5/lab-1-introduction-to-labview>

<http://www.eeherald.com/section/design-guide/esmod14.html>

<http://davidallmon.com/pages/ccd-transmission-spectrograph>

<http://www.integralist.co.uk/posts/guide-to-js-testing.html>

<https://www.mathworks.com/help/supportpkg/arduino/ug/use-serial-communications-with-arduino-hardware.html>

<http://www.integralist.co.uk/posts/guide-to-js-testing.html>



# 11 APPENDICES

## 11.1 APPENDIX A- COPYRIGHT PERMISSIONS

### Copyright Permissions

EEHerald.com

To  editor@eeherald.com X

Cc

Copy right permission|

Hi,

Sync 00000001	PID XXXX XXXX	Frame number XXXXXXXXXXXX	End Point XXXX	CRC XXXXX	EOP
------------------	------------------	------------------------------	-------------------	--------------	-----

My name is Kevin Orkis and I am doing a senior design project for UCF and would like to use one of your pictures from your website. I need permission however I was wondering if you could point me in the right direction to get these.  
Thank you  
Kevin Orkis

### Labview Pictures

Send us an email. We will respond to your request in 1-2 business days.

<b>First Name</b> Kevin	<b>Last Name</b> Orkis
<b>Phone Number</b> 4079379821	<b>Preferred Time to Call You</b> e.g. ASAP, 3pm-5pm EST, Tue 2-4pm CS
<b>Email Address</b> KORKIS2@knights.ucf.edu	<b>Confirm Email Address</b> KORKIS2@knights.ucf.edu
<b>Your Company Name</b> e.g. Company Name /University	
<b>Postal Code</b> 32806	
<b>Select a Subject</b> Select One	
<b>Email Message</b> Hi I am a student doing a senior design project for <u>ucf</u> and would like to use one of your pictures from your website. Could you point me in the right direction on where to get that permission. Thank you Kevin Orkis	

Cancel Submit

## Power Supply Standards

### Contact Us



#### Headquarters

20050 SW 112th Avenue  
Tualatin, OR 97062  
Toll Free: 800-275-4899  
Phone: 503-612-2300  
Fax: 503-612-2383

Good Morning, My Name is Matthew Aviles. I am a student at the University of Central Florida. I am currently working on a project in Senior Design 1 at UCF. I wanted to know if I could use your Power Supply Standards and the circuit definitions in Supply Safety Standards, Agencies and Marks. Thanks.

 Stay Up-to-Date

Keep me current with the latest product releases, technical resources and company updates from CUI.

Your information is collected only for the purpose of contacting you. CUI will not share any of your information with other companies or individuals. Read more about our [privacy policy](#) and [terms of use](#) for details

## CCD Detector

**From:** [David Allmon](#)

**Sent:** Wednesday, November 23, 2016 12:04 PM

**To:** [mattaviles](#)

**Subject:** Re: Comment Form: [DavidAllmon.com](#)

Matthew,

You can use whatever you want from the site - that's why it is there.

Good luck with your project!

Dave

> On Nov 23, 2016, at 9:12 AM, A website visitor <[dallmon2@dca12.com](mailto:dallmon2@dca12.com)> wrote:

>

> Hi Dave,

> I just wanted to say the work you have done is incredible. I wanted to ask  
> you permission if I could use your circuit and some of your code in a school  
> project Im working on. I will source you on all ccd arduino sensing and just  
> wanted to ask if It was okay that I do so.

> Thanks you for helping out novice like me learning about arduino and ccds.

> Matthew

> [mattaviles@knights.ucf.edu](mailto:mattaviles@knights.ucf.edu)

>

## Microcontroller theory

### Raspberry pi RISC Architecture

You are here: [Home](#) > [Contact ARM](#)

#### Contact ARM

- > Product Enquiries
- > Technical Support
- > ARM Connected Community
- > Mailing List Subscriptions
- > ARM Offices
- > Recruitment Enquiries
- > University Relations
- > Investor Enquiries
- > Media Enquiries
- > Website Issues

## Enquiry Form

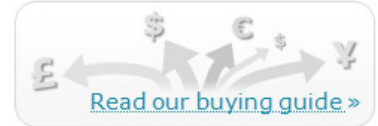

Required entries are marked in **bold**

**Type of Enquiry:** Product Enquiries

**Message:**

Good Morning, My name is Matthew Aviles. I am a student at the University of Central Florida. I am currently in Senior Design 1 and would like to use your RISC Architecture picture for my research paper. Thanks

1790 characters left

**Message Subject:** Picture Research Paper Request

**Last Name:** Aviles

**First Name:** Matthew

**Organization:** UCF

Job Title:

**Email:** mattaviles@knights.ucf.edu

**Telephone:** 4078232000

**State (USA Only):** Florida ▼

**Country:** USA ▼

# Arduino Uno Hardware Architecture:



## Contact

**PLEASE NOTE:** Adafruit does not have a retail store, orders cannot be picked up. **NO VISITORS ARE PERMITTED.** Our factory is not available for visits.

If you need technical support for your purchase from Adafruit, please visit the [Adafruit customer support forums](#) where we have dedicated technical support engineers that will be able to assist you quickly. While we answer all questions in the [customer support forums](#), we do not provide one-on-one email or telephone consulting. Our engineers will answer questions, troubleshoot, handle replacements and assist you in the [Adafruit customer support forums](#).

Please [log in](#) to provide us with more information.

Full Name:

Email Address:

Confirm E-Mail:

Category:

Please supply a detailed description of your Press/Media inquiry.

**At this time the Adafruit team is not taking on any new speaking engagements** - we are growing fast and 100% focused on our customers and product development at this time. Additionally, we are not offering any sponsorships for events, etc. at this time.

Good Morning [Adafruit](#).  
My Name is Matthew [Aviles](#). I am a student at the University of Central Florida. Currently I am writing a research paper for Senior Design 1 and would like to use your image of the [Arduino Uno Hardware Architecture](#).  
Thanks.

Send Message

## Laser Blocking



BUY SUPPORT VISIT ARDUINO.CC SEARCH

## CONTACT US, STORE SUPPORT

How can we help you? Please submit your request using this form.

Name:

Email:

Type of question:

Order Number / Tracking Number:

Subject:

Message:

SEND MESSAGE

## TMP36 circuit and temp sensor

**B** *I* U  **A**         Undo  Redo

From: mattaviles@knights.ucf.edu 

To: [support@learningaboutelectronics.com](mailto:support@learningaboutelectronics.com);

 Cc & Bcc

Request Permission for use of TMP36 Circuit and Part Picture

Good Morning,

My Name is Matthew Aviles. Currently, I am a student at the University of Central Florida. I am in Senior Deisgn 1, and I am writing a paper. I would like to use your TMP36 circuit picture and part picture.

Thanks,

-Matthew Aviles|

## Digital Temperature sensor

### Contact Us



On this page, you will find a form that allows you to contact us directly. Note that you will rarely need this and that this is really only intended for questions or comments that have no place in article comments or the forum. Think about reporting website problems, and questions of a private nature like advertising questions, etc...

#### WARNING

You rarely will need this form!

Messages that could be answered in the **forum** or in article comments (at the bottom of an article) **will be ignored**.

### Contact Us Form

All fields are required!

 Matthew





 mattaviles@knights.uc

 Do not change this field

Good Morning, My name is Matthew Aviles. I am a student at the University of Central Florida. I am currently in Senior Design and i wanted to know if i could use your picture in my research paper. Thanks

 Send Message

## Cold cooling plate

**B** *I* U  A ▾ |    ▾ | Heading 1 ▾ | ↶ Undo ↷ Redo

From: mattaviles@knights.ucf.edu



To: [cool@totech.com](mailto:cool@totech.com);

 Cc & Bcc

Request Permission

Good Morning,

My Name is Matthew Aviles. I am a student at the University of Central Florida. Currently, I am writing a paper for my senior design project. I wanted to know if I could use your cold cooling plate picture.

Thanks,  
Matthew Aviles|