



Solar Sculpture Project

Senior Design I Documentation

University of Central Florida
Department of Electrical & Computer Engineering

Fall 2016
Senior Design I

Group #10
Sponsored by Orlando Utilities Commission

Carolyn Cressman	Electrical Engineering
Jose Jerez	Electrical Engineering
Carla Majluf	Computer Engineering
Ruben Vazquez	Computer Engineering

TABLE OF CONTENTS

1.0 Executive Summary	1
2.0 Project Description	3
2.1 Project Motivation	3
2.2 Project Goals	5
2.3 Requirements Specifications	6
2.3.1 Project Specifications	6
2.3.2 Control Unit Specifications.....	7
2.3.3 Wi-Fi Module Specifications.....	7
2.3.4 Inverter Specifications	7
2.3.5 Maximum Power Point Tracking (MPPT) Specifications.....	8
2.3.6 Photovoltaic Solar Panel Specifications	8
2.3.7 Sensor Specifications.....	8
2.3.8 Motor Specifications.....	8
2.3.9 Motor Driver Specifications	9
2.3.10 Battery Specifications.....	9
2.4 Quality of House Analysis.....	9
3.0 Related Standards and Realistic Design Constraints	11
3.1 Standards	11
3.1.1 General Design of PV Systems	11
3.1.2 Disconnect Means and Breakers.....	13
3.1.3 Wiring and Conduit	13
3.1.4 Grounding, Bonding, and Lightning Protection.....	13
3.2 Realistic Design Constraints.....	14
3.2.1 Economic and Time Constraints.....	15
3.2.2 Environmental, Social, and Political Constraints.....	15
3.2.3 Ethical, Health, and Safety Constraints	16
3.2.4 Maintainability and Sustainability Constraints	17
4.0 Research	18
4.1 Existing Similar Projects	18
4.1.1 Smart Umbrella	18
4.1.2 Wi-Fi Seeking Robot.....	18
4.1.3 Nepenthes Solar Powered Sculpture	19
4.1.4 PV Stained Glass.....	20
4.2 Control Units	21
4.2.1 Overview and Types of Control Units.....	21
4.2.2 Comparisons of Instruction Set Architectures	22
4.2.3 Comparison of Control Unit Types.....	24
4.2.4 MCU Product Comparison	25
4.2.5 Wi-Fi Module Product Comparison	26
4.3 Photovoltaic (PV) Panels.....	29

4.3.1	The Photovoltaic Effect in Solar Panels and Consideration	29
4.3.2	Types of Panels	32
4.3.3	PV Watts.....	33
4.3.4	Product Comparison	35
4.4	DC/AC Inverter and Converter.....	35
4.4.1	Overview and Types of Inverters	35
4.4.2	Converter.....	39
4.5	Maximum Power Point Tracking, Charge Controller, and Battery	41
4.5.1	MPPT	41
4.5.2	Charge Controller and Battery.....	43
4.5.3	Product Comparison	45
4.6	Voltage Regulator	46
4.7	Light Sensor	47
4.7.1	Overview of Light Sensor.....	47
4.7.2	Classification of Light Sensors	48
4.7.3	Types of Light Sensors.....	48
4.7.4	Product Comparison	51
4.8	Current Sensor	52
4.8.1	Types of Current Sensors.....	52
4.8.2	Product Comparison	53
4.9	Motors	53
4.9.1	Overview and Types of Control Motors	53
4.9.2	Motor Product Comparisons	57
4.9.3	Stepper Motor Driver Comparisons.....	59
4.10	Wireless Communications	60
5.0	Project Hardware and Schematics	63
5.1	Initial Design Architectures and Related Diagrams.....	63
5.1.1	Full-scale System Overview.....	63
5.1.2	Initial Design for Full-Scale Sculpture.....	64
5.1.3	Current Design for Full-Scale Sculpture	65
5.1.4	Structure for the Full-Scale Sculpture.....	66
5.1.5	Wiring for the Full-Scale Sculpture.....	67
5.1.6	Prototype System Overview.....	67
5.2	Power Subsystem	68
5.2.1	MPPT/Charge Controller	68
5.2.2	Battery.....	69
5.2.3	Voltage Regulators	72
5.2.4	Current Sensor.....	76
5.2.5	Solar Panel	77
5.2.6	MPPT System Design and Operation.....	77
5.3	Motion Subsystem	85
5.3.1	Motion Subsystem Overview.....	85
5.3.2	Microcontroller Design Layout.....	85

5.3.3	<i>Light Sensor Design</i>	87
5.3.4	<i>Motor Driver Design Layout</i>	90
5.3.5	<i>Structural Considerations and Motor Design</i>	93
5.3.6	<i>Motor Subsystem Schematics</i>	94
5.4	Wireless Information Transmission Subsystem	98
5.4.1	<i>Microcontroller Connection to Server</i>	99
5.4.2	<i>Web Server</i>	99
5.4.3	<i>Website</i>	100
5.4.4	<i>Wireless Module Hardware</i>	102
6.0	Project Prototype Construction and Coding	105
6.1	Parts Acquisition	105
6.1.1	<i>Parts Distributors and Resources</i>	105
6.1.2	<i>Parts and Components</i>	106
6.2	PCB Vendor and Assembly	107
6.2.1	<i>PCB Manufacturers</i>	107
6.2.2	<i>Project Construction Resources</i>	107
6.3	Final Coding Plan	108
7.0	Project Prototype Testing Plan	111
7.1	Hardware Test Environment	111
7.1.1	<i>Sensor Tests</i>	112
7.1.2	<i>Motor Controller Test</i>	113
7.2	Hardware Specific Testing.....	115
7.2.1	<i>Battery Life</i>	115
7.2.2	<i>Battery Charging</i>	115
7.3	Software Test Environment	118
7.4	Software Specific Testing	118
7.4.1	<i>Wireless Communication Tests</i>	118
7.4.2	<i>Solar Tracking Test</i>	120
7.5	Integration Testing	121
8.0	Administrative Content	123
8.1	Milestone Discussion	123
8.2	Budget and Finance Discussion	124
8.2.1	<i>Project Sponsorship</i>	124
8.2.2	<i>Project Spending</i>	125
Appendix A: Copyright Permission Emails		I
Appendix B: Work Cited		VIII

1.0 Executive Summary

The intent of this project is to design and implement a solar sculpture for the OUC/UCF partnership contest. Our project will consist of the design of the full-scale sculpture and the execution of this design in a small scale. This will be done by collaborating with teams from the mechanical engineering and art departments. The art team will have the task of making an aesthetically pleasing overall design for the sculpture. The mechanical engineering team will provide a concise structural analysis and recommendations of the most viable materials for the construction of the sculpture. The role of the EECE team in this project will be to design and prototype the system that will harvest energy from the sun and power the sculpture, as well as the solar tracking mechanism and the user display of the sculpture's performance.

Our sponsor is the Orlando Utilities Commission which will be providing the service of building the final solar sculpture design to Tavistock, a development company responsible for the Lake Nona community. OUC will select which of the three multi-disciplinary sponsored groups' design will be implemented. The selected design will be built in a green area in downtown Lake Nona. This area is often used for community events such as hosting the local farmers market. Our multi-disciplinary team intends to satisfy the need of our sponsor's customer for a very special art piece that promotes the use of clean energy.

Our team is composed of four members. Two students majoring in electrical engineering, Jose Jerez and Carolyn Cressman, and two majoring in computer engineering, Ruben Vazquez and Carla Majluf. Relevant classes and work experience have made this team qualified to take on this project. Carolyn Cressman has plenty of practical knowledge from working with temporary power and having an internship as a quality engineer at Walt Disney World. Jose Jerez has taken courses that are highly applicable to this project such as Power Systems and Power Electronics. Ruben Vazquez has experience with front and back end development. He also belongs to a professional organization, Phi Theta Kappa Delta Omicron, which has prepared him for leadership positions. Carla Majluf also has experience with front and back end software development. Also, she has taken Embedded Systems which make students familiar with the use of microcontrollers. The electrical engineers will be in charge of the electrical circuits that will power the structure, they will design the electrical connections necessary for the system to work as well as the necessary energy conversions. The computer engineers will handle the control system of the sculpture which entails the microcontroller and the software that will dictate the actions of the sculpture's components.

In order to build a high quality and fully functional prototype, we have divided the system into several subsystems that will have different purposes. The power subsystem will be in charge of harvesting solar energy and transforming it into electrical energy that will be stored on a battery so the prototype functions even if it isn't currently receiving direct sunlight. This subsystem is composed by the solar panel, the voltage regulator and the MPPT/charge controller. The motion subsystem will consist of two motors mounted on a movable frame. This motors will be controlled by the microcontroller which will use to information received by the light sensors to adjust the position of the solar panel for maximum solar energy absorption. The sensor subsystem will be comprised of the light sensors as well as a current sensor and a voltage sensor. The light sensors will send the microcontroller the information of the coordinates of most direct sunlight. The current sensor and voltage divider will provide the microcontroller with the necessary information to calculate the power generated by the solar panel at a given time. The wireless subsystem will send the power generated data to a web server so it can be displayed in a website. This transmission will be done by a WiFi module that will be connected to our microcontroller, allowing it to connect a nearby wireless network.

The integrated approach taken in this project is what makes it so revolutionary. STEAM (Sciences Technology Engineering Arts Mathematics) is a recently developed term which describes the combination of the arts and sciences disciplines. It is very important in the education field as we currently see more and more holistic approaches in academic activities. This is why this project brings so much opportunity to make a global impact. Additionally, the product of this multi-disciplinary proposal will be innovative because there's very few solar sculptures in the Orlando area. Our community spaces are filled with displays of art in different shapes and sizes but there's certainly a lack of educative displays that integrate multiple disciplines. This is why we firmly believe that a solar sculpture that integrates solar tracking and wireless communications will make a great positive impact in our community.

2.0 Project Description

Our sponsor, OUC, has currently deployed 5 solar sculpture, scattered throughout Orlando. The locations of the current sculpture include the Orange County Convention Center and the Citrus Bowl. They current sculptures pictured below in Figure 2.0.1 are available from the market but are very industrial looking.



Figure 2.0.1 – OUC Current Solar Sculptures

Our sponsor is looking for a very artistic sculpture to be placed in Lake Nona's Laureate Park community, pictured in Figure 2.0.2. This location is home to community events such as farmer's markets and movie nights. Its purpose is to educate about solar energy, convince more homeowners to install solar panels, and act as a community landmark.



Figure 2.0.2 – Images of Laureate Park Elements

2.1 Project Motivation

In the midst of the environmental degeneration of our planet, the need for clean energy becomes more and more evident. Solar energy derived from photovoltaics is a solid alternative to conventional forms of energy because it is cost competitive and it does not damage the atmosphere. However, people have shown some uneasiness when it comes to integrating solar panels into their buildings. Hence, we are very motivated to prove that photovoltaics can be incorporated into structures without making them any less appealing. An interactive solar sculpture placed in a location widely accessed by members of the Lake Nona community is an enormous opportunity to teach them about the benefits of clean renewable energy and to encourage the practice of switching to this type of energy sources in the Orlando area.

We were very excited to work with solar energy because it's an emerging technology whose implementation has increased radically in the past 10 years. There are several benefits of using solar energy. The main one is that it is non-polluting. Solar energy is clean, reliable and renewable, as opposed to fossil fuels which pollute the air by releasing carbon dioxide, nitrogen oxide and sulphur oxide. Also, solar energy doesn't need other kinds of fuel to produce electrical power which completely eliminates the extra complications of transporting the fuel and the storing of toxic waste. The fact that solar energy is a renewable source of power is also one of its great benefits. Most of the earth's surface receives sunlight so this makes solar energy a highly consistent form of energy. Additionally, it is easily harnessed, needing only the installation of solar panels. This reduces our need to import other sources of energy into our country. Another benefit of solar energy is that it is very low maintenance. Solar cells last very long and one of the reasons for this is that they don't have any moving parts. The panels have a simple installation and they don't need any power sources. There's plenty of flexibility in the fact that more solar panels can be added in the future as needed. Even though there's an initial high investment due to the cost of the solar panels and their installation, the recurring costs are minimal and the money can be recovered over time with the savings that this technology generates. Also, solar panels can be integrated into a great variety of structures ranging from residential buildings to mobile devices. Unlike Eolic energy generators, they do not require large fields since they can be arranged in a distributed fashion. Finally, solar energy can be of great help in remote areas where people have no access to electricity because running power lines would be too expensive or geographically impossible.

In addition to the highly motivating factors described above, our team was eager to learn and practice new skills that will be of great use when we graduate and enter the workforce. The electrical engineers were excited about applying the theoretical knowledge learned in class to fabricate the power system of our

sculpture. The computer engineers loved the idea of being in charge of the control unit and creating the proper software interface for our project. Also, our group believes that extremely important non-technical skills will be learned or reinforced during the execution of this project. These skills are:

- Working as a part of a team: Actively listening to other group members and providing individual input to build a final product.
- Troubleshooting: Finding causes of operating errors during the process of implementing the design and taking action to eliminate this causes.
- Critical thinking: Logically identifying the right way to approach a topic and making conclusions about it.
- Reading comprehension: Reading multiple sources of information on the systems we don't understand and processing it in an organized form in the research section of this document.
- Technology design: Adapting equipment to create a product that fits our requirements.
- Complex problem solving: Reviewing related information to develop options to solve a complex problem.
- Active learning: Comprehending the implications of new information and applying it according to our needs.
- System analysis: Understanding how the changes in conditions, operations and environmental factors will affect how a system works.
- Decision making: Comparing costs versus benefits of potential actions such as acquiring certain components versus others.

2.2 Project Goals

The overall goal of this project is to contribute to the solar sculpture design made by our multi-disciplinary team by building a prototype for the electronic system of the sculpture. This system will encompass not only the power system that will convert solar energy into electrical power but also the system that tracks the optimal angle for direct sunlight and the system that communicates how much power is being absorbed. Taking this into consideration we have decided that the project will have the following objectives: Solar Tracking, Solar Charging and Wireless Communication.

The Solar Tracking goal brings into our prototype the ability to track the coordinates of best exposure to direct sunlight. The prototype will be placed outside and, autonomously, it will use its motors to move its frame and position itself in angle where its solar panel is directly facing the most sunlight. This is an important function because the solar sculpture will be feeding energy into the grid. Also, our sponsor gave us the requirement of a certain amount of Kilowatts that our sculpture

has to generate per year so we would like to have the maximum absorption of energy that is possible.

For the Solar Charging function, the goal is to harvest the energy from the sun and store it in a battery. The actual solar sculpture design won't have a battery but we decided to include one in our prototype to be able to properly display all the other features. The energy collected will power the motors for the solar tracking system as well as the microcontroller and its peripherals. The objective of this function is to have a continuous power supply for the prototype so it can function through long periods of time.

The final goal, Wireless Communication, will equip our prototype to send data over the internet. Another requirement specified by our sponsor was that there needs to be a display where the community will be able to read in understandable terms how much power the sculpture is producing. For this, our group will design and develop a website which will display the information that was previously sent by the control unit in the solar sculpture. The objective of this function is to implement an effective communication link and to make sure that the information accessed by the community is in terms that people without a technical background can comprehend.

2.3 Requirements Specifications

2.3.1 Project Specifications

The specifications for the project are listed below. These specifications serve as basis for the specifications of each component of the project. In sections 2.3.2 through 2.3.11, the specifications for the components will be highlighted. The project specifications are as follows:

1. Low power - The components must consume less power than is produced by solar energy alone.
2. Lightweight - The components should weigh less than 40 lbs.
3. Long lifespan - The components should operate in normal conditions for a minimum of five years.
4. Low maintenance - The product should require little to no maintenance when running under normal operations.
5. Weather resistant - The final product and all of its components must be able to withstand temperatures of at least 90 degrees Fahrenheit and high humidity conditions.
6. Low cost - The components should cost no more than \$500.
7. Precision - The solar panels should be oriented towards the sunlight to attain maximum power efficiency.

8. Transportability - The product should be able to be easily transported to different locales.
9. Standalone - The components should be able to function without relying on the sculpture.

2.3.2 Control Unit Specifications

The specifications for the control unit are listed below:

1. Low power - The control unit shall be powered on a maximum operating voltage of 5 V.
2. Lightweight - The control unit will weigh less than 2 lbs.
3. Motor control - The control unit shall be able to provide control for at least one motor.
4. Sensors - The control unit shall be able to interface with at least three sensors.
5. Weather resistant - The control unit should be able to withstand high temperature and humidity conditions.
6. Low cost - The control unit should cost no more than \$50.
7. The control unit shall have an operating frequency at least 20 MHz
8. The control unit shall have analog input pins to be able to receive voltage readings.
9. The control unit shall have at least 128 kB of flash memory.
10. The control unit shall be able to communicate with a Wi-Fi module.

2.3.3 Wi-Fi Module Specifications

The specifications for the Wi-Fi module are listed below:

1. Low power - The Wi-Fi module shall be powered on a maximum operating voltage of 5 V.
2. Compliance - The Wi-Fi module will be in compliance with IEEE 802.11 standards for wireless communications.
3. The Wi-Fi module shall communicate using frequencies within the ISM band range.
4. It should be able to connect to the internet wirelessly.

2.3.4 Inverter Specifications

The specifications for the inverter are listed below:

1. The inverter selected for the full-scale model should be a UL-listed (Underwriter's Laboratory) device and comply with UL1741 standard.
2. Inverter for the full-scale structure should also abide by NEC Article 690 and IEEE 1547 standards.
3. Inverter should safely feed the power from the solar panel into the electric grid.

2.3.5 Maximum Power Point Tracking (MPPT) Specifications

The specifications for the MPPT are listed below:

1. MPPT should safely regulate the solar panel voltage and maximize the input power to it
2. The output voltage from it should also safely charge the batteries and have integrated overcharge protection

2.3.6 Photovoltaic Solar Panel Specifications

The specifications for the solar panels are listed below:

1. The solar panels used in the full-scale structure shall be UL listed.

2.3.7 Sensor Specifications

The specifications for the sensors are listed below:

1. The sensor shall be able to connect to control unit and send data to the control unit.
2. The sensor must be able to measure more than the maximum current produced by the solar panel.
3. The sensor must have good accuracy, meaning the sensitivity must be as large as possible.
4. The sensor should have an operating voltage of 3.3V, in order to simplify circuitry.

2.3.8 Motor Specifications

The specifications for the motors are listed below:

1. Control - The motor should be able to receive signals from the control unit.
2. Lightweight - Both motors should weigh no more than 2 pounds in total.

3. Low cost - Each motor will cost no more than \$20.
4. High torque - The motor should be able to move and hold the solar panels in place.
5. Low current - Each motor should draw less than 1 A of current from the motor driver

2.3.9 Motor Driver Specifications

The specifications for the motor driver are listed below:

1. Current regulation - The driver should have adjustable current control to prevent motor damage.

2.3.10 Battery Specifications

Although only the prototype structure will require a battery, the specifications for them are listed below:

1. Battery voltage should be greater than or equal to the largest required voltage in other components.
2. Battery capacity should large enough to power components for at least 10 minutes.
3. Battery should be rechargeable using solar power from the panels.

2.4 House of Quality Analysis

A House of Quality chart visually displays the tradeoff associated with each engineering and marketing requirements. Below in Figure 2.4.1 is our House of Quality chart including our engineering goals. When considering a particular design, you need to know the requirements and their priority to your client/sponsor. After attending some initial meetings with our client/sponsor we believe the priority of their marketing requirements is as shown in Table 2.4.1. The client would like for the sculpture to be aesthetically pleasing above all else. Know the order of priority allows us to make better decisions when making tradeoffs during the design process. Knowing aesthetics is main priority we know that the art department might choose to use individual solar cells over full size panels.

<i>Priority</i>	<i>Marketing Req.</i>
<i>First</i>	Aesthetics
<i>Second</i>	Ease of Use
<i>Third</i>	Power Output

Fourth

Cost

Table 2.4.1 – Priority of Marketing Requirements for Client

		Engineering Requirements					
		<i>Energy production efficiency</i>	<i>Power Output</i>	<i>Power Consumption</i>	<i>Dimensions</i>	<i>Cost</i>	
Marketing Requirements			+	+	+	-	-
	<i>Aesthetics</i>	+	↓	↓	↓		↓
	<i>Power Output</i>	+	↑	↑ ↑		↓	↓
	<i>Ease of use</i>	+	↓				↓
	<i>Cost</i>	-	↓	↓	↓	↓	↑ ↑
	<i>Engineering Goals</i>		At least 80% efficiency	At least 50W	Under 25W	No larger than 8' diameter and 15' tall	Prototype should cost no more than \$1000

Figure 2.4.1 – House of Quality

3.0 Related Standards and Realistic Design Constraints

3.1 Standards

Codes and standards are utilized to provide a sort of checklist for design projects. The standards are a means to protect consumers by standardizing certain characteristics of products such as sizes and safety of the product. Also, standards ensure that each installation doesn't adversely affect the surrounding environment. Standards are created by professionals in industries related to the standards they are create. When adapted by the governing body these codes and standards must be followed; failing to follow these codes and standards could result in delays in the design and installation of a product. In section 3.1.1-3.1.4 are some related standards with a brief overview of these standards and their impact our design.

3.1.1 General Design of PV Systems

Article 690 of the NEC code is applied to PV systems like our design. The article requires all equipment to be identified, listed for application, and for markings at system point of interconnection. Article 690 also requires that PV system conductors be placed in separate raceways, junction boxes, and fittings than non-PV system conductors. The PV source and output must be run along building structural members such as trusses and columns given the location of these elements can be determined visually. The NEC article 690 specifies a qualified person, as defined by the article, must install PV systems, associated wiring, and interconnections.

This article provides a standard for calculating maximum voltage using the Table 690.7, shown below as Table 3.1.1, and manufacturer data. This code requires components to be identified and listed for the application, for ground fault protection to be included in the system, current can only be 1.25 times the short circuit current, and minimum ampacity and overcurrent can only be 1.25 times the maximum current. In this article 690.9, overcurrent protection, states that overcurrent protection is generally required on all systems except when there is no feedback or when total I_{max} is less than conductor ampacity. Article 310.15 of the NEC code requires separate ampacity adjustment depending on the number of conductors in a bundle as shown in Figure 3.1.1.

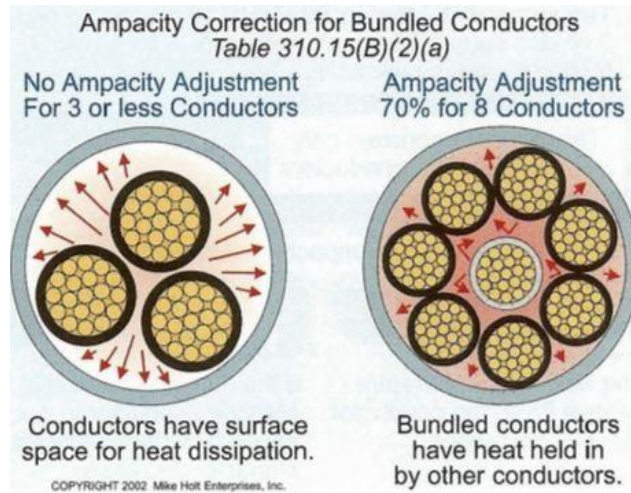

Figure 3.1.1 - Ampacity for Bundled Conductors

Table 690.7 Voltage Correction Factors		
Lowest-Expected Ambient Temperature °C °F		Temperature Correction Factor
0 to 4	32 to 40	1.10
-1 to -5	23 to 31	1.12
-6 to -10	14 to 22	1.14
-11 to -15	5 to 13	1.16
-16 to -20	4 to -4	1.18
-21 to -25	-5 to -13	1.20
-26 to -30	-14 to -22	1.21
-31 to -35	-23 to -31	1.23
-36 to -40	-32 to -40	1.25

Table 3.1.1 - NEC Table 690.7 Maximum Voltage Calculation

During the design process we will be referring to the IEEE standard 1562, which is a design standard for sizing PV arrays. In order to decrease the temperature of the array the array should not be directly mounted to the roof structure; it is best to mount the array in an open rack. Elevated temperature caused by lack of airflow can decrease output voltage and power, sometimes reducing to a voltage too low to even charge a battery.

Per the sponsor requirements, the equipment should meet UL standards, IEC standards, be UL 1703 listed. The UL 1703 details multiple tests a product must pass in order to be listed. The following are some of those tests, arcing test, salt spray test, water spray test, leakage current test, strain relief test, fire test, impact test, wet-insulation test, and humidity test.

3.1.2 Disconnect Means and Breakers

The NEC article 690 requires the means to disconnect all conductors from the building, provide location of disconnect, and have signage warning when line and load are energized. The grounded conductor is not required to have a disconnect means. Listed inverter are required for grid connected systems and the point of connection must have a dedicated breaker that is 120% of busbar or conductor. The inverter must be placed in a not-readily accessible location. Location of the disconnecting means must follow the rules outlined by 690.14 which are as follows, both the AC and DC disconnect must be within sight of the inverter, the AC output conductors from the inverter and additional AC disconnect for the inverter shall comply with 690.14, and a plaque shall be installed in accordance with 705.10.

3.1.3 Wiring and Conduit

NEC article 690 allows single conductors to be outside of conduit in the PV array. The article requires temperature correction to be applied to the conductors and calls out requirements for connectors for the wiring. NEC 690.31 requires that where DC PV source or output circuits are run inside a building or structure shall contain metallic raceways or metal enclosures from the point of penetration of the surface of the building or structure to the first readily accessible disconnecting means. Also, this section requires the following, where PV source and output circuits operating at maximum system voltages over 30V are install in readily accessible locations, circuit conductors shall be installed in a raceway. Article 310.15(B)(2) requires where conductors or cables are installed in conduits directly exposed to sunlight adjusts in Table 310.15(B)(2)(c), shown below as Table 3.1.2, shall be added to the outdoor temperature to determine the applicable ambient temperature for application of the correction factors in Table 310.16 and Table 310.8.

<i>Distance above roof to bottom of conduit</i>	°C	°F
<i>0 – 1/2"</i>	33	60
<i>1/2" – 3 1/2"</i>	22	40
<i>3 1/2" – 12"</i>	17	30
<i>12" – 36"</i>	14	25

Table 3.1.2 - Section from Table 310.15(B)(2)(c)

3.1.4 Grounding, Bonding, and Lightning Protection

One of the most important elements in a structure containing electrical equipment. Grounding provides personal safety and minimizes the damage caused by

lightning and surges on equipment. The NEC article 690 defines grounding as a connection to earth with very low impedance and sufficient current-carrying capacity in order to prevent voltage build up. Article 690 requires systems over 50Vdc to be grounded as outline in article 690 section 5. The system is to have one grounding point at the GFP device if provided. Equipment must be grounded as well; any metal likely to be energized must be grounded. The article allows for listed equipment to be used to bond modules to support structure.

The UL Standard 1703 require the grounding means to be bonded to each conductive part of the module or panel and it must be accessible during normal use. Separate bonding conductor or strap must be copper, copper alloy, or other material acceptable for use as an electrical conductor, be protected from mechanical damage, and it cannot be secured by a removable fastener used for any purpose other than bonding. The connection of the bond can be any of the following, clamping, riveting, bolted, screwed, welded, soldered, or brazed. The bonding connection cannot penetrate nonconductive coatings; such as paint or vitreous enamel. A EGC shall be identified and/or marked with a G, GR, GROUND, GROUNDING or the like, or shall have green colored part, no other terminal can be identified as such.

NEC article 690 requires the system to have DC ground fault protection except if one of the following are true, the system is ground or pole mounted array with no more than two parallel circuits with all dc source and output circuits isolated from the building or the PV array is installed at other than dwelling units where the grounding conductor is sized in accordance with 690.45. For non-dwelling units where GFP isn't provided 690.45 requires each EGC shall have ampacity of at least two times the temperature and conduit fill corrected circuit conductor ampacity. Locating the grounding connection point closer to the PV source better protects the system from voltage surges due to lightning.

Article 690.43 requires equipment grounding conductors for the PV array and structure shall be contained within the same raceway or cable or otherwise run with the PV array circuit conductors when those circuit conductors leave the vicinity of the PV array. The size of the EGC is outlined in 690.45 as follows, EGC in PV circuits shall be sized in accordance with Table 250.122; where no overcurrent protective device is used in the circuit, an assumed overcurrent device rated at the PV rated short circuit current shall be used in Table 250.122; the EGC shall be no smaller than 14 AWG.

3.2 Realistic Design Constraints

Design constraints are imposed by the community and/or stakeholders and limit product design. These constraints can fall into many categories such as

environmental, safety, and social. Each of these types of constraints has an effect on our design. The constraints we will need to consider determine how well our design would behave once it is construct and being used. This is important because often a design doesn't consider simple everyday actions such as maintenance and weather. In the following sections, 3.2.1 – 3.2.4, we will discuss what realistic design constraints apply to our design.

3.2.1 Economic and Time Constraints

Economic constraints are constraints that effect the cost of our design, production, and maintenance. The best solar cells and panels are newer, recently developed, and produce more power per square meter; but these solar cells and panels have a higher cost. The panels that are listed and meet the related standards also have a higher cost; those that are not listed will not meet the stakeholder requirements and may result in the permit being denied in the future when the sculpture is installed. Due to the amount of time we have to acquire our components, we must order are parts through third party retailers which is more expensive than order in bulk directly from the manufacturer.

Time constraints are constraints caused by the deadlines of the project. With our partnering groups from Mechanical and Art on separate schedules, time will have the greatest constraint on our design. With each partner we will have a whole new set of concepts to address and potentially large design changes late in the process. With this in mind, we aim for a largely flexible and easy to integrate design. Keeping our features simply will help combat the time constraint. Our major element so far will be the solar tracking feature which is achievable in our time frame and can be worked on separate from the sculpture shape and size. Any added ascetic elements such as lighting will be easy to obtain and install later in the semester.

3.2.2 Environmental, Social, and Political Constraints

Environmental constraints are constraints on how the product may affect the environment in which it may be used and Earth's natural resources. One of the environmental restrictions for electrical components is the Restrictions of Hazardous Substances (RoHS). This restricts the amount of six hazardous materials found in electrical components. The energy produced by our sculpture though small will decrease that amount of fossil fuels consumed to produce electricity; in turn this will decrease carbon emissions into the atmosphere. The stakeholders want the sculpture to produce more than it consumes which constrains our design to energy efficient devices in order to produce the most energy after our sculptures consumption.

Social constraints are the constraints that a community places on the design. Our design should blend in terms of style with the surround area and businesses. The design would need to be non-intrusive to events at or around the structure; these restricts noise, sound, and lighting intensity involved in the sculpture design. For our solar array using panels would be the easiest and simple solution however the ridge structure of a solar panel is not as visually pleasing as using individual cells the ascetic constraint could cause us to go with the latter mentioned. The stakeholders purpose for this project is to convince people solar can be ascetically pleasing and to convince them to place solar panels on their homes; this considered it is preferred that are panels/cells be in the line of sight for the consumers and that they fit within the artwork.

Political constraints are those types of constraints that affect the design due to politics. In this case the politics are those of our sponsor OUC, their goal is to further educate the public about solar energy and to help convince the people of the community that solar energy isn't an eye sore. The above requires the power information display to relate power consumption in a way people can really understand; our solar tracking feature will help achieve this goal. This feature will allow us to compare power production of the tracking system vs. the stationary system. The stakeholder requirement to communicate this power information in a way the public with all types of backgrounds can easily understand, places a constraint on what we do with our power information and website software to meet this requirement. Some of the ways we will consider is communicating production of energy in terms of dollars per watt charged by the utility companies or in terms of how many light bulbs can be powered for one hour with the energy produced.

3.2.1 Ethical, Health, and Safety Constraints

Ethical constraints are restrictions on a product due to ethical concerns. For our design our personal and professional ethics place a constraint that our design meets safety codes and standards and is dependable. We also are obligated to present the best design we can achieve with research and testing to back up our circuit design. To achieve this each portion of the project will be heavily research, codes and standards will be observed, and we will be testing every part and the overall design several times before the final presentation in front of the department and stakeholders.

Health and safety constraints are any restrictions on product design due to the health and safety concerns. Most of the health and safety constraints are placed on our design from the safety code and standards talked about above in section 3.1; I will summarize some of these constraints here. Grounding, bonding, and lightening protection will be a large part of our design due to the height of our sculpture. These items will need to be considered and included to protect

consumers and electrical equipment. Proper sizing of the solar panel cabling is also a very important constraint; if not properly sized the cables can be effect as well as consumers. Inclusion of proper disconnects and/or breakers this would allow de-energization in cases of maintenance and emergency to reduce risk of injury and death. Finally, all electrical components will meet both the stakeholder requirement and governing standard to have only listed components included in the design; for the demo design this may not be achievable because smaller components are often not listed but the full-scale design will meet this requirement.

3.2.4 Maintainability and Sustainability Constraints

Maintainability constraints are the time and cost constraints associated with maintenance. For our solar tracking portion of our design the motors and movement of the sculpture over time will require maintenance in order to maintain quality of operation. Though we will be using two batteries in our demo design, the full-scale will have no battery backup in order to reduce maintenance needs. As we work with the mechanical team on the overall sculpture we will need to keep in mind the need for little to no maintenance stakeholder requirement with any additional lighting or other ascetic elements. The stakeholder would like to limit maintenance, one of the ways to decrease this is some self-cleaning ability in the design. To address this, we will have the solar panels at an angle larger than 10 degrees in order to allow rain to do some cleaning on the solar panels. When maintenance is needed the components should be easily accessible and easy to change out.

Sustainability constraints are constraints that that affect the operational lifetime of the product under normal operating conditions. The stakeholder expressed a want for a longevity of at least 5 years up to 20 years; ultimately the longer the design lasts the better the return on the investment. In order to meet this constraint, we will look for components with warranties, testing related to sustainability, and that are produced by well-known and respected companies with quality products. The movement of the solar panel will also create a sustainability constraint; movement causes strain on cabling and mechanical elements; to address this we need to include slack in the cabling to reduce strain.

4.0 Research

4.1 Existing Similar Projects

4.1.1 Smart Umbrella

The smart umbrella is a project previously done by UCF students in the spring of 2015. It is a beach umbrella with charging and lighting capabilities. The umbrella has strips of flexible solar cells on top of it which enable it to capture the sun's energy to charge lithium ion batteries that are housed within the umbrella. That electricity can then be used to both charge phones through USB and power a set of lights that are on the umbrella. They also use two motors and a light sensor to implement two-axis sun tracking and therefore maximize the amount of power coming into the cells.

The smart umbrella has many similarities to what the solar sculpture will have and need to implement. First off, both projects make use of solar power and batteries. Both projects will require maximum power point tracking in order to maximize the power coming in from the solar panels and into the battery. They also required a charge controller that would safely charge their battery, something that we will also require for our prototype so that we can actually use the power from our solar panels. They also used two stepper motors in order to implement two-axis sun tracking and required a way to control the motor and keep it where it needs to stay. Their design project was used as a reference for part of our own project and some of the parts they used or considered were also considered for our use.

4.1.2 Wi-Fi Seeker Robot

The Wi-Fi seeker robot is previous project made by UCF students built in the fall of 2014. The robot uses an on-board solar panel and two lithium-ion batteries that power the electronics found on the robot. They required the use of an MPPT/charge controller board which would efficiently and safely charge their batteries, a voltage regulator board to power their 5V and 3.3V electronic components, a motor controller board that could control their four motors, and a main board that housed their microcontroller and took in the information from the sensors to then make decisions on the movement of the robot.

Parts of their project were used as a reference for our prototype design. The charge controller with maximum power point tracking component that the group used was also considered for use in our own project and we also used some of the same resources they listed in their power design section, like the TI Webench Design

Center. Also, like them, we decided to separate our voltage regulator board from our MPPT/charge controller board. We will also keep our logic board separate.

4.1.3 Nepenthes Solar Powered Sculpture

The Nepenthes Solar Sculpture is a sculpture in Portland, Oregon created by Dan Corson, show below in Figure 4.1.1. It's a 17-foot sculpture inspired by the “monkey cups” which is a tropical plant whose leaves resemble vases and provide water for local monkeys. The sculpture is made of multiple layers of translucent fiberglass and a steel spine. Inside the sculpture there are white LEDs wrapped around the steel spine of the structure. The solar panels on the structure are custom made, shown in Figure 4.1.2. These solar panels power the batteries contained within the sculpture and the batteries are used to power the LEDs during the night time.



Figure 4.1.1 – Nepenthes Solar Sculpture by Dan Corson [4.1.1]



Figure 4.1.2 – Custom Solar Panels for Nepenthes [4.1.1]

This project is more focused towards art, which is the same focus our sponsor has. Our sculpture could take a similar shape and could use LEDs in a similar way to this project. Something to note in this project is the custom made solar panels which allow for the maximum number of solar cells in a given area; which might be good to keep in mind in the full-scale design.

4.1.4 PV Stained Glass

The PV Stained Glass is a structure with solar cells imbedded in between two panes of glass and was created by artist Sarah Hall. The solar cells are placed in different patterns and the panes of glass are stained and patterned. Figure 4.1.3, below, shows the PV Stained Glass project.

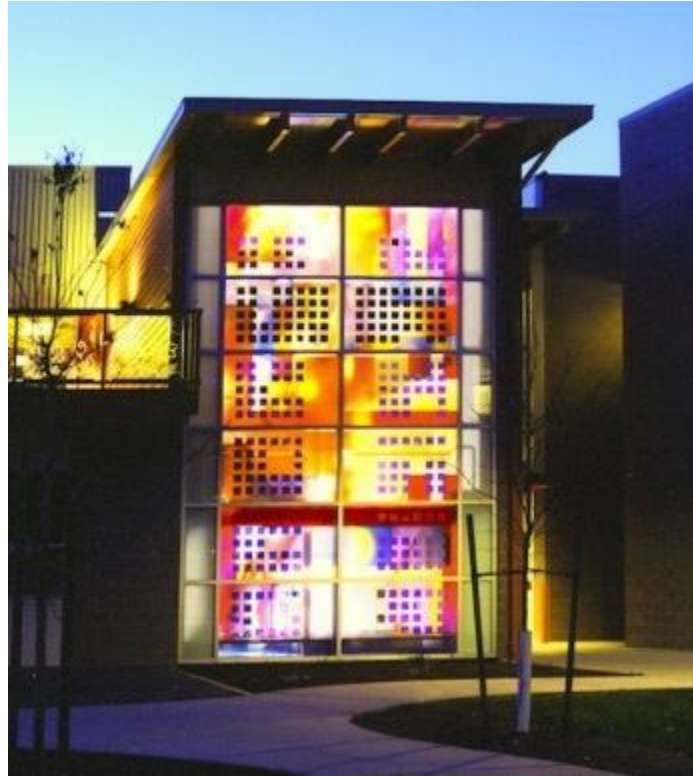

Figure 4.1.3 – PV Stained Glass by Sarah Hall [4.1.2]

4.2 Control Units

4.2.1 Overview and Types of Control Units

Reading the data and adjusting the orientation of the solar sculpture will require some type of control unit to process the signals from the sensors and to send signals to tell the motor to change orientation. For consideration, there are three types of units.

First, there are Application-Specific Integrated Circuits, or ASICs. These are microchips that are designed for specific tasks in contrast to general-purpose integrated circuits, which, for example, include the family of microprocessors and RAM chips. In addition, there are three types of ASICs: Full Custom Design, Semi-Custom Design, and Programmable ASICs. First, in Full Custom Design, everything for the chip is designed from scratch: placement of circuit elements, logic elements, and other required components for specific features are designed and no existing implementations or libraries are used in this process. As a result, these types of chips benefit in terms of maximized efficiency and usage of resources at the cost of a long design and production phase, which could possibly take years to complete. Next, Semi-Custom Design consists of using existing

libraries when creating these chips and can make the process of creating such chips easier. Lastly, Programmable ASICs can be split up into two different types of devices: Programmable Logic Devices, PLDs, and Field-Programmable Gate Arrays, FPGAs, the latter of which will be the topic of discussion in the next paragraph. Some common PLDs are ROM, EPROM, and EEPROM.

Next, are Field-Programmable Gate Arrays, or FPGAs. These products consist of an array of configurable logic blocks that can be reprogrammed to meet the functionality desired for its intended purpose. As such, these devices can be initially programmed for a specific set of tasks and can be modified later if functions need to be added or removed, making it extremely useful for projects that are intended to be upgraded, or modified, over time. Just like the ASICs, there are a wide variety of applications, such as those in the areas of audio and wireless communication, which we will have to work with for this sculpture.

Lastly, we have the Microcontrollers, sometimes shown as μC . Microcontrollers are system-on-chip, or SOC, devices that are usually embedded as part of a larger system and are dedicated to the control of the system. These chips also feature several general-purpose input and output ports, with some of them designed for the purpose of processing analog signals, ROM, RAM, and others peripherals. Microcontrollers are programmed using a device called a programmer to interface the chip with another computer. Once the program is written, it is stored in the ROM of the microcontroller and the program starts its execution, continuing its execution given that chip is powered, typically with about 5 Volts and some others running with 3.3 Volts. Microcontrollers can also be wired together to provide extra functionality which may not be present on a single controller by itself. A nice example of this is a general microcontroller unit, or MCU, connected a Wi-Fi-capable module to add Wi-Fi capability to the MCU. This can be generalized to any type of combination between compatible controllers; however, not all controllers require the same voltage to run. In fact, using a higher voltage than specified can cause damage to the pins of the microcontroller or to the whole device itself, thus resulting in a faulty or otherwise unusable microcontroller. To alleviate this, some MCUs have a logic level shifter to prevent damage from higher voltages. Not all MCUs have this. In this case, a voltage divider circuit can be used to provide some sort of control over the voltages present between the connected MCUs.

4.2.2 Comparisons of Instruction Set Architectures

Microcontrollers, like all processors and chips, have an Instruction Set Architecture, ISA, that essentially explains how a processor or chip processes the instructions necessary to perform work. Two common types of ISAs are as follows: Reduced Instruction Set Computer, RISC, and Complex Instruction Set Computer.

Both of these architectures have their advantages and not one is preferred than the other; however, it helps to understand how these chips function and to see the comparison between the two. For both ISAs, we will look at the multiplication instruction and discuss the general idea of how to implement this instruction in both ISAs. To start, RISC architectures function by using very simple instructions to perform one small task at a time. So, for the multiplication instruction, it can be split into four simpler instructions:

1. Load the multiplier/multiplicand from memory into a register.
2. Load the multiplicand/multiplier from memory into another register.
3. Calculate the product of the two loaded values.
4. Store the product back into memory.

Looking at this approach, we will need to store all of these instructions memory. Also, every instruction should be completed in one clock cycle, which most RISC architectures operate for. In contrast, CISC architectures are built to instructions that are higher in complexity as compared to RISC architectures. So, the multiplication instruction can possibly be completed in one step, generally, if the processor is designed that way:

1. Take the values from memory, calculate the product, and store back into memory.

With this approach, only one instruction has to be stored in memory and this instruction will take multiple clock cycles to complete. Now, looking at the comparison of these approaches for both architectures, more memory will be required to store the instructions for the RISC architecture as opposed to the CISC architecture. Also, since instructions may require multiple steps to perform the operations, the hardware for the CISC ends up being more complex than that of the RISC, which usually performs one operation per instruction. This is also correlated to the difference of lock cycles required per instruction, or CPI, between the RISC and CISC; however, at a higher level, an in-depth knowledge of the hardware for the processors is not necessary. In the end, RISC and CISC architectures use different implementations of hardware but perform quite competitively with each other. Both types of architectures will be able to realize our planned functionality, with slight differences in the higher level programming required. To conclude, below Table 4.2.1 is showing a general comparison between RISC and CISC architectures.

CISC	RISC
Emphasis on hardware	Emphasis on software
Includes multi-clock	Single-clock
complex instructions	reduced instruction only
Memory-to-memory: "LOAD" and "STORE" incorporated in instructions	Register to register: "LOAD" and "STORE" are independent instructions
high cycles per second, Small code sizes	Low cycles per second, large code sizes
Transistors used for storing complex instructions	Spends more transistors on memory registers

Table 4.2.1 – CISC vs RISC

4.2.3 Comparison of Control Unit Types

After considering the different types of control units that we can use to implement our design, the microcontroller is able to provide us with the necessary peripherals to create a solar tracking device that can send power data, over Wi-Fi, to a web server. ASICs provide an incredible level of customizability; however, even with a Semi-Custom Design approach, it would take months to complete the initial design of the integrated circuit, which is more time than we have to work with for this project. Also, the knowledge and understanding required to design a chip of some complexity would take additional time to acquire, on top of the time required to design the chip. Overall, the requirements for the electronics component of the solar sculpture does not lend itself well to warrant the design, or usage, of an ASIC. FPGAs, on the other hand, are a better choice for this project. They can be obtained off-the-shelf at much lower price than an ASIC and are much lower maintenance than ASICs overall, which is one aspect that is very sought out for this design. While FPGAs give us a much better option than ASICs, they contain much more functionality than what we really require. The main aspect of FPGAs is their re-configurability, which makes them ideal for iterative and incremental work, where functional units can be added on or removed as desired by the team or requirements. With the requirements of the sculpture, re-configurability is not necessary and, despite the fact that FPGAs are much lower maintenance than ASICs, would add some amount of maintenance if we decided to add extra functionality in the future.

Knowing the pros and cons of the ASICs and FPGAs, we have decided to use a microcontroller as the control unit for the structure. In general, microcontrollers have varying amounts of general-purpose input and output pins that we can connect sensors to in order to collect data from the solar panels. In addition, some microcontrollers also come with analog input and output pins to take in voltage readings. Lastly, the microcontroller can also send data, via Wi-Fi, to a web server and use pulse-width modulation, PWM, to control a servo motor for the solar tracker. As a result, the microcontroller provides the necessary peripherals to implement our desired functionality, as specified in our requirements specifications. The next section will highlight different microcontroller units (MCUs) and Wi-Fi modules in order to evaluate a specific set of components to implement our design.

4.2.4 MCU Product Comparisons

The MCU and the Wi-Fi module that we would like to use have to be able to perform certain tasks. The two main functions that we would like to implement for the sculpture is solar tracking to maximize power output for the solar panel and data accessibility to educate the public on the benefits of solar power. First we will focus on the selection of the MCU. We will require the MCU to be able to process the data from the solar panels while also changing the orientation of the panels, using that data, to increase our power output. This can be achieved by connecting the MCU to a motor, the latter of which will be discussed in section 4.2. As such, the MCU should have enough general purpose input and output pins to interface with the number of motors. Also, to collect the data to display for the users and the data to determine the change in orientation for the solar panels, analog pins also need to be considered for the MCU. In the following paragraphs, two MCUs will be considered: the ATmega328 and the SAM D21.

First, we will discuss the ATmega328. Some features and peripherals of the ATmega328 include the following: RISC architecture, 32 pins, 20 MHz operating frequency, UART for serial communication, 8 Analog-to-Digital conversion (ADC) channels, 2 kB of SRAM, 1 kB of EEPROM, operating voltage between 1.8 and 5.5 Volts, 6 Pulse Width Modulation (PWM) channels, and debug. Wire for interfacing with the chip.

Second, the SAM D21 is a series of MCUs that feature low-power operating voltage (1.62 to 3.63 Volts), up to 256 kB of Flash memory, up to 32 kB of static RAM, operates at 48 MHz with several timers, 20 PWM channels, 14 ADC channels, and 6 Serial Communication Interface (SERCOM) channels, that can be configured for three different modes: I2C, SPI, and USART, among the different features.

When comparing the ATmega328 and the SAM D21 series of MCUs, an important consideration is the operating voltage. The solar panels will be connected to the power grid and will need to produce more power than it consumes; otherwise, there is no net gain in power. The SAM D21 series operates at a maximum of 3.63 volts which is quite desirable for low power applications. Also, compared to the ATmega328, the SAM D21 comes with many more analog and PWM channels which is great for scalability, allowing for more solar panels and motors to be controlled using the SAM D21, along with more than double the operating frequency, allowing for more computations and instructions executed per second. Table 4.2.2 features comparisons for the ATmega328 and the SAM D21 MCUs.

	Atmel ATmega328/P	Atmel SAMD21G18
Cost	\$9.00	\$24.95
Operating Voltage (Volts)	1.8 - 5.5	1.62 - 3.63
SRAM (kB)	2	32
EEPROM (kB)	1	0 - 16
Flash Memory (kB)	32	256
# of Digital Pins	15	24
# Analog Pins	8	14
Input Voltage for I/O Pins (Volts)	0.5 - 6.0	0 - 3.8
Operating Frequency (MHz)	20	48

Table 4.2.2 – Control Unit Comparison

4.2.5 Wi-Fi Module Product Comparisons

Since collection and display of the power data to civilians is a requirement, we require a module that is capable of performing these functions. One way to do this is to use sensors to collect the data from the solar panels for the MCU to process and then send to some database, where we can store records for each reading at preset intervals. This database would be on a web server that would host a site where this data can be taken from the database and displayed to visitors. Another way of doing this is to not store the data at all and simply send the data straight to the site to be displayed. In either case, data would have to be sent over some wireless connection. The MCUs that we have discussed in the previous section do

not have integrated wireless capabilities. As a result, we will use a Wi-Fi module to send this data wirelessly to our site. With this in mind, two Wi-Fi modules are considered in the following paragraphs: The ATSAMW25 and the ATWINC1500 series of Wi-Fi modules.

The ATSAMW25 is a module that is comprised of different integrated circuits; two of which happen to be the SAM D21 chip, discussed in the previous section, and the ATWINC1500, which will be discussed later in this section. The MCU and integrated circuits that are part of this package are the following: The SAM D21 MCU, the ATWINC1510B for Wi-Fi capabilities, the ATECC508A for memory and crypto authentication, and the SI1865DDL load switch. Since this chip uses the SAM D21 as its MCU, it contains most of the general purpose input and output pins that the SAM D21 and we can refer to the SAM D21 datasheet for more information on those pins. Some of the features of the ATSAMW25 include the following: An operating voltage range from 2.7 to 3.6 volts, IEEE 802.11 b / g / n 20MHz standard, 256 kB of Flash memory, 32 kB of static RAM, and SPI / UART capabilities. The module also comes built with various security protocols (WPA Personal, WPA2 Personal, TLS, and SSL) and network services (DHCP, DNS, TCP/IP (IPv4), UDP, HTTP, and HTTPS). For more information, please refer to the ATSAMW25 datasheet on the Atmel website, currently located at <http://www.atmel.com/devices/ATSAMW25.aspx?tab=parameters>.

Next, the ATWINC1500 series is a Wi-Fi module, that was also a part of the ATSAMW25 above. Some of the key features of this module include the following: IEEE 802.11 b / g / n support, SPI, UART, and I2C capabilities, operating voltage between 3.0 and 4.2 volts, integrated Flash memory, and a 2.4 GHz ISM band for unlicensed radio frequency use. In addition to these key features, the ATWINC1500 also has the same security protocols and network services as the ATSAMW25. To conclude, the ATWINC1500 also has acceptance by many companies and worldwide standards (FCC from the United States, CE from Europe, and TELEC). For more information, please refer to the ATWINC1500 datasheet on the Atmel website, currently located at <http://www.atmel.com/devices/ATWINC1500.aspx>

Both of these chips, the ATSAMW25 and the ATWINC1500, have very similar features, since one chip is a part of the other, namely the ATSAMW25 has the ATWINC1500 integrated with other chips. As a result, there is not a big difference when looking at the features of each of these chips alone; however, the ATSAMW25 contains more devices, as highlighted in its Bill of Materials (BOM), than the ATWINC1500. This, in turn, will translate into a higher cost for features of the ATSAMW25 that we may not even use. For our requirements, we need to be able to send data wirelessly to a web server from an MCU. The content of the data is not sensitive, being only power data from the solar panels and should not require

the crypto authentication that the ATSAMW25 can provide. After reviewing the documentation for the ATSAMW25 and the ATWINC1500, the ATWINC1500 looks like a promising choice for fulfilling our requirement of sending our collected data to a web server and displaying the data to the users. Table 4.2.3 features comparisons for the ATSAMW25 and the ATWINC1500 Wi-Fi modules.

	Atmel ATSAMW25	Adafruit ATWINC1500 Breakout
Cost	\$23.70	\$24.95
Operating Voltage (Volts)	2.7 - 3.6	3.0 - 4.2
# of Pins	51	40
Temp. Range (Celsius)	-40 - 85	-40 - 85
Frequency Band (GHz)	2.4	2.4
Max Data Rate (Mb/s)	72	72
# of SPI Channels	1	1
# of I2C Channels	2	0
# of USB Transceivers	2	0
# of UART channels	0	1
Wi-Fi protocols	802.11 b/g/n	802.11 b/g/n

Table 4.2.3 – Wi-Fi Comparison

4.3 Photovoltaic (PV) Panels

4.3.1 The Photovoltaic Effect in Solar Panels and Considerations

The photovoltaic effect is what allows solar cells to work. Solar cells are made of semi-conductor materials which react to the sun's light depending on their bandgap energy. Put simply, the photovoltaic effect happens when a semiconductor material is exposed to light and that light causes the excitation of an electron to a higher-energy state within that material. This energy gap between states is known as its bandgap energy and it varies in magnitude from material to material. Its magnitude determines whether the material is a conductor, insulator, or semiconductor with conductors having the smallest bandgap energy and insulators the largest. The separation of charge that is created by the electrons moving in energy state creates a voltage that can then be used to generate electricity. The sun's light is made up of different frequencies of light that carry different energy levels. Although there are many semiconductor materials out there, no one type can respond to the full range of the sun's light. However, solar cells can layer different types of semiconductors in series to make them respond to a wider range of the sun's energy. It is therefore important to compare and contrast what kinds of solar panels are available on the market today so that we can choose the appropriate panel type.

PV modules consist of multiple individual solar cells connected together, nearly always in series. The reason for this is that the voltage is generally increased to be compatible with a 12V battery. Since charging a battery of that voltage requires 15V or more, enough cells are strung together to give an open-circuit voltage of about 21V and an operating voltage of about 18V. The excess is to account for voltage drops due to other elements and reductions in light intensity. A series-connected set of cells or modules is called a string while a parallel-connected string is called a block.

Temperature is one factor that can negatively affect solar panel performance, as shown below in Figure 4.3.1. The efficiency of a solar cell actually decreases with increasing temperature. This is because the magnitude of the electric field at the p-n junction is reduced by an increase in conductivity of the semiconductor due to the increase in temperature. This will lead to a lower voltage across the cell. Electron mobility also increases, causing a small increase in current also. However, it is not significant when compared to the voltage loss. The optimal environment for a solar cell is a sunny and cold environment.

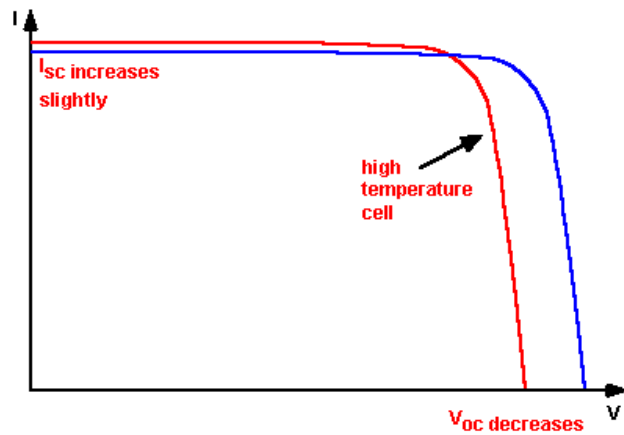

Figure 4.3.1 - The effect of temperature on the IV characteristics of a solar cell

Shading is another big concern for solar panels since shading in just one cell can reduce the power output to zero, as shown in Figure 4.3.2 below. The output of a single cell declines proportionally to the amount of shading but since the cells in a module, like a panel, are all connected in series, shading in a single cell causes the string of cells to fall to the level of the shaded cells. The potential location of our sculpture in Lake Nona does not have any high-standing trees or buildings around it but we will need to make sure that our panel are arranged in such a way that no one element of the structure is blocking a panel.

Hot spot heating is another factor to consider. It occurs when there is one low current cell in a string of several higher current cells. If the current of the string is limited by the bad cell, the forward bias on the good cell will reverse bias the bad cell, leading to a dissipation of power and possible failure in the bad cell. The figure below shows this.

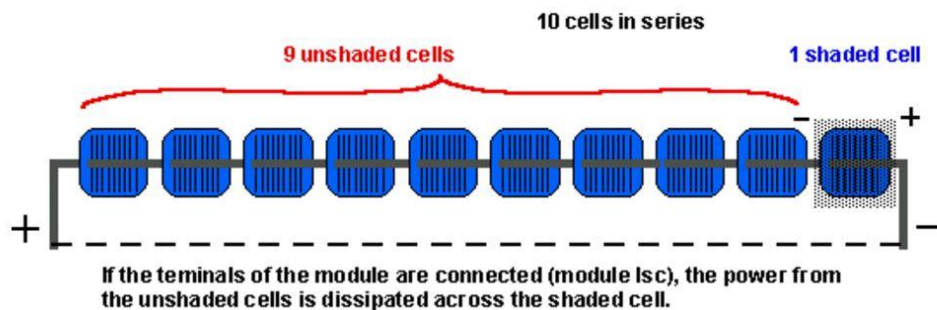

Figure 4.3.2 - Hot Spot Heating

One way to negate this damaging effect is to use bypass diodes, as shown in Figure 4.3.3 below. A bypass diode is connected in parallel and opposite polarity to a group of solar cells. Under normal operation, the diode is simply an open

circuit. But when there is a hot spot developing, it will conduct, allowing the current from the good cells to flow in the external circuit.

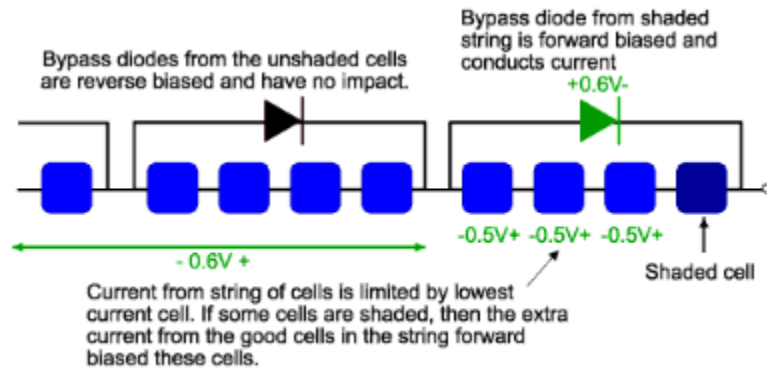

Figure 4.3.3 - Using bypass diodes to prevent hot spot heating

A 36-cell panel will typically have two bypass diodes, shown in Figure 4.3.4. The concept also applies to larger arrays. Bypass diodes will help reduce the impact of mismatch losses from modules connected in series. Another necessity is a blocking diode. These are used to prevent current flow from the battery through the panels and to prevent current flowing from one parallel string into a lower current string, as shown below.

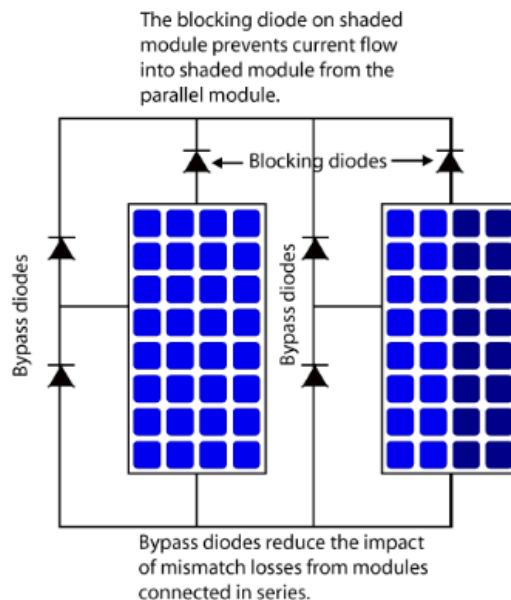

Figure 4.3.4 - Bypass and blocking diodes

4.3.2 Types of Panels

Crystalline Silicon (c-Si) cells make up the vast majority of the current market. The panels vary in size and purity though. The pure the silicon is, the better the solar cell is at converting sunlight into electricity. However, the processes used to enhance the purity are expensive and most consumers are more worried about cost and space. C-Si cells break down into two main categories: monocrystalline and polycrystalline solar cells.

Monocrystalline cells are evenly-colored, have rounded edges, and a uniform look. More importantly, monocrystalline cells are purer and the most efficient solar cells on the U.S. market today, with efficiencies reaching above 21%. They are also space efficient because of the amount of power they yield, live longer than other types of panels, and tend to perform better than other panels in low-light conditions. However, they are also the most expensive and can be sensitive to partial-shading and temperature.

Polycrystalline cells have a regular rectangular look and are made by melting and pouring raw silicon into a square mold to then be cut. The advantage to using these kinds of cells is mainly that they are less expensive but nearly every other parameter is worse than those of a monocrystalline cell. They are less efficient and therefore require more space per watt, are more heat sensitive, and tend to have shorter lifespans.

Thin-Film Solar Cells (TSFC) are made by depositing several thin layers of photovoltaic material onto a substrate. Here too, there are different types depending on which material is deposited onto the substrate. They can be made of amorphous silicon (a-Si), cadmium telluride (CdTe), copper indium gallium selenide (CIS/CIGS), and many other materials. Their advantages are that they are easy to mass produce and potentially cheaper, they tend to look more appealing than their crystalline counterparts, they can be made flexible, and higher temperatures and shading have less impact on the cell performance. Their disadvantages are that they tend to require a lot more space per watt because of lower cell efficiencies, this also mean that structures to support them can be more expensive, and their lifespan is generally much shorter.

Amorphous Silicon (a-Si) solar cells output low electrical power and have mainly been used in small-scale applications like pocket calculators. Recent innovations have made them more attractive for larger-scale applications but they still would not be suitable for our application. To compare the different types of solar panels we created Table 4.3.1 shown below.

CELL TYPE	CRYSTALLINE SILICON		THIN FILM
	MONOCRYSTALLINE	POLYCRYSTALLINE	AMORPHOUS SILICON
EFFICIENCY (%)	15-22	13-16	5-7
TEMPERATURE PERFORMANCE	< 3% drop	< 3.5% drop	< 1% drop
COST (\$ per watt)	1.10 - 1.40	0.80 - 0.90	0.45 - 0.53
WEIGHT (lb per ft ³)	15.3	22.9	8.7
AESTHETICS	Black Checkered	Blue Checkered	Flexible, Homogeneous
ADDITIONAL DETAILS	Most Common	Economical	High Surface Area Requirements

Table 4.3.1 – Comparison of Solar Panel Types

4.3.3 PV Watts

We utilized the Department of Energy’s web tool, PV Watts, to analyze the energy in kW for different types of solar cells and solar arrays. Figure 4.3.5 shows the results from PV Watts for a 2-axis tracking array with standard solar cells. The PV Watts web tool displays the average amount of sun hours for each month in a year for the arrays given location, the average energy per month in kWh, and the amount of money saved based on the energy produced and the cost per kWh.

To compare the different types of solar arrays, we ran the PV Watts analysis for 2-axis tracking, 1-axis tracking, and fixed. We also ran each type of array using thin cells and standard cells. The results are shown below in Table 4.2.2. From the table we can see the thin cell 2-axis tracking is the best array to collect the most energy. Also, from the results below we can clearly see that the thin cell types of solar panels produce more energy in each array type. Even though the thin cells produce more energy the energy value is not that different from the standard cell types.

My Location 13615 Sachs Avenue, Orlando, FL 32827
[» Change Location](#)

[HELP](#) [FEEDBACK](#)

ALL NREL SOLAR TOOLS

RESOURCE DATA SYSTEM INFO RESULTS

RESULTS

996 kWh per Year *

Print Results

[Go to system info](#)

Month	Solar Radiation (kWh / m ² / day)	AC Energy (kWh)	Energy Value (\$)
January	4.77	67	9
February	5.35	67	9
March	6.78	93	12
April	8.19	107	14
May	7.97	106	14
June	6.90	89	12
July	6.45	85	11
August	6.12	81	11
September	5.96	76	10
October	5.75	78	10
November	5.81	76	10
December	5.30	73	10
Annual	6.28	998	\$ 132

Figure 4.3.5 – PV Watts Results for 2-Axis Tracking Array with Standard Solar Cells

Type of Solar Array	Type of Solar Cell	AC Energy Annually (kW)	Energy Value Annually
2 Axis Tracking	Standard	996	\$132
	Thin	1041	\$138
1 Axis Tracking	Standard	921	\$121
	Thin	962	\$127
Fixed	Standard	772	\$102
	Thin	800	\$107

Table 4.3.2 – Solar Arrays Comparison

4.3.4 Product Comparison

After reviewing the types of PV technologies that are currently available, we decided to focus our search on crystalline panels. Two similar panel types were compared, one a polycrystalline and the other a monocrystalline, shown in Table 4.3.3.

	<i>Renogy 260W Monocrystalline Solar Panel</i>	<i>SolarWorld Sunmodule 260W Polycrystalline Solar Panel</i>
<i>Maximum Power</i>	260W	260W
<i>Open Circuit Voltage</i>	37.6V	38.4V
<i>MPP Voltage</i>	30.4V	31.4V
<i>MPP Current</i>	8.56A	8.37A
<i>Efficiency</i>	15.37%	15.51%
<i>Dimensions</i>	64.5x39.0x1.6 in.	65.95x39.4x1.3 in.
<i>Weight</i>	40 lbs.	39.7 lbs.
<i>Connector</i>	MC4 connectors	H4 connectors
<i>Price / Unit</i>	\$244.99	\$196.00
<i>Price / Watt</i>	\$0.942	\$0.754

Table 4.3.3 – Solar Panel Comparison

The difference in performance between the two types of technologies does not seem large enough to justify the higher cost monocrystalline panels for the size that we are looking at. However, we did find that more efficient monocrystalline modules reaching 20%+ efficiency are available at a much higher cost. These are typically available in 320W+ configurations which are larger than what we are looking to use in the structure so they will not be considered.

In order to implement this for our prototype, we will use a 50W polycrystalline panel that is already available for us through UCF. This will allow us to start our prototype testing sooner and keep the cost of the prototype down.

4.4 DC/AC Inverter and Converter

4.4.1 Overview and Types of Inverters

Because our electric grid is based on AC electricity, we must have way of converting the DC power into AC. Two types of inverters currently exist in the

market--modified sine wave and pure sine wave inverters. Modified sine wave inverters output something similar to a square wave, as shown below in Figure 4.4.1. Its RMS values equal those of a sine wave of similar amplitude and they are relatively simple to implement since only a few frequencies need to be summed up. Pure sine wave inverters tend to be more expensive because of the extra control and filtering stages that are necessary. They produce an output that is identical to what comes out of an electrical outlet and can run more sensitive devices that a modified sine wave inverter may cause damage to. Things like laser printers, power tools, and medical equipment require a true sine wave input to run efficiently and without risk for damage. Pure sine wave inverters also have a lower harmonic distortion which means they are more efficient as any harmonics outside of the fundamental frequency lower the overall efficiency. Inductive loads like motors will also run faster and quieter because of this.

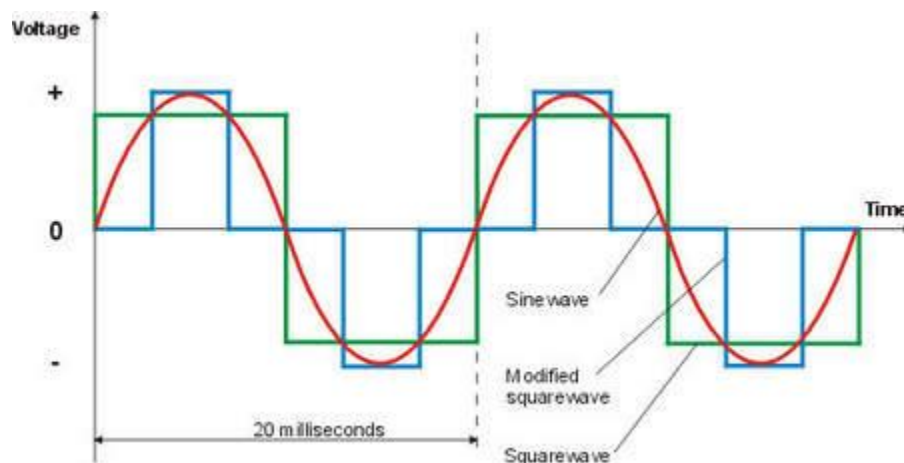

Figure 4.4.1 Difference between a modified sine wave vs. pure sine wave

In order to tie our inverter to the electric grid, it must be a pure sine wave inverter. It must also abide by NEC Article 690 and IEEE 1547 codes which govern the standards for interconnecting distributed resources with the electric power system. For this reason, the inverter in the full-scale OUC design must also be able to synchronize to interface with a utility line and have an anti-islanding feature, which means it should stop producing power when the electric grid is down, else it could be dangerous for utility workers who might not realize that a circuit is still powered. The inverter must also be UL-listed (Underwriters Laboratory) and compliant with the UL1741 standard.

Another factor to be considered is the watt size of the inverter. It should supply two needs: surge power and typical power. They may also be referred to as peak and usual power, respectively. Surge power is the maximum power that the inverter can provide for a short time. This is important because some appliances like

electric motors or pumps will require a much higher startup surge than they do when running. Typical power is what the inverter has to provide on a steady basis. It is the continuous rating.

Inverters come in size rating from 50W to 50KW and up. Units larger than 11KW are seldom used for household PV systems. All inverters have a continuous and surge rating. The surge will be specified for a length of time but 3-15 seconds is enough to cover almost all appliances. High speed switching inverters tend to have lower surge ratings than low-frequency switching counterparts. However, they also tend to be smaller and more inexpensive. Since we will be immediately feeding the solar panel power into the electric grid and powering our sculpture separately, the surge rating will not be an important factor for us.

Another factor that must be considered in choosing an inverter for the full-scale structure is whether it should be three-phase or one-phase. Solar systems greater than 6kW should generally be three-phase, since feeding that much solar power into a single phase could create an imbalance between the loading of the phases. For systems smaller than 3kW this isn't generally an issue because feeding 3kW of power onto one phase is not usually a problem. Because our system will be smaller than 3kW, we will only consider one-phase inverters.

There is another kind of inverter we could possibly use and that is a microinverter shown below in Figure 4.4.2. These are inverters that convert the direct current of a single solar module to alternating current. The output from several of these can then be combined and fed to the electrical grid. Their main advantage is that small amounts of shading, debris or even a complete module failure do not disproportionately reduce the output of the entire array. Each panel would have its own microinverter harvesting optimum power with its own maximum power point tracker. It can therefore isolate and tune the output of that single panel and those panels would no longer all have to be facing in the same direction at the same angle. Each one could be set on an opposing side of the structure without affecting the other panel in any way. They also claim to have more reliability than string inverters and a longer mean time between failure (MTBF).



Figure 4.4.2 - EnPhase 280 Microinverter

The wiring would also yield an advantage. Because the output of the panels would now be AC, almost no DC wires would have to be used. This is beneficial because DC wiring requirements and regulations are highly technical and restrictive. AC wiring is much more efficient in carrying electricity leading to higher productivity out of the PV system. It can also be argued that the system would also be safer, since there would be no high voltage DC lines. High voltage DC means a malfunctioning fault or connection point can create continuous arc faults, increasing the potential for fires or electrocution. The highest voltage seen would be the typical 120 VAC.

The main disadvantage of micro inverters is that they have a higher initial equipment cost per watt than that of a single string inverter. This also makes them harder to maintain and more expensive to remove and replace. Each one has its own set of inputs and outputs, in its own box. Each of those boxes must then be weatherproofed. Microinverters also generally have a lower efficiency than string inverters although that highly depends on the environment that the system is in. Their lack of market demand means that less effort, time, and money has been put into making improvements in the technology. As of today, all large-scale solar farms use central/string inverters to feed their electricity onto the grid as shown in Figure 4.4.3 below.

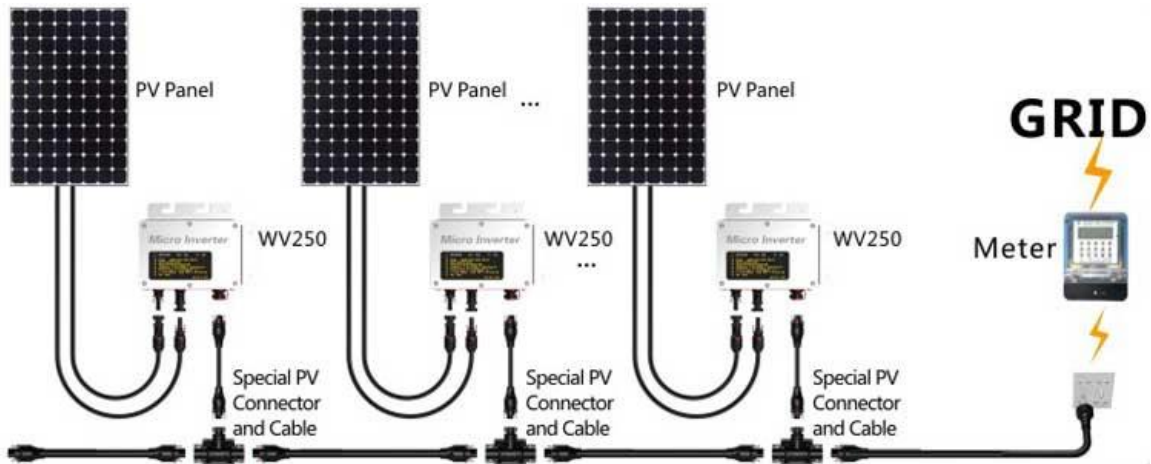

Figure 4.4.3 - Diagram for a microinverter Solar System

Although recent improvements in technology have made these kinds of inverters more efficient and cost friendly, most of the improvements and cost-savings have tended to go more towards the string inverters since they are more commercially viable. Because of this, we are tending more towards the simple setup of a string inverter for the full-scale model.

4.4.2 Converter

As stated in the previous section, we will not be using the solar panels to directly power our structure. The power from the panels will go straight into the electric grid. The reason for this is to minimize maintenance requirements and cost. Since we do need a way of powering our structure, we will need an AC/DC converter to power the electronic components that the art team, mechanical team, or we decide to put on the structure.

Another component we may need for the full-scale design is a DC/DC converter. This is because most inverters require a large DC voltage input in order to function. This minimum input voltage is usually over 100V and if we only string two or three panels in series we would not meet that requirement. A boost, or flyback, converter would solve this issue and potentially make the inverter run more efficiently since it would maintain that minimum input voltage. The diagram in Figure 4.4.4 below shows a typical layout of a battery-less, grid-tied solar energy system.

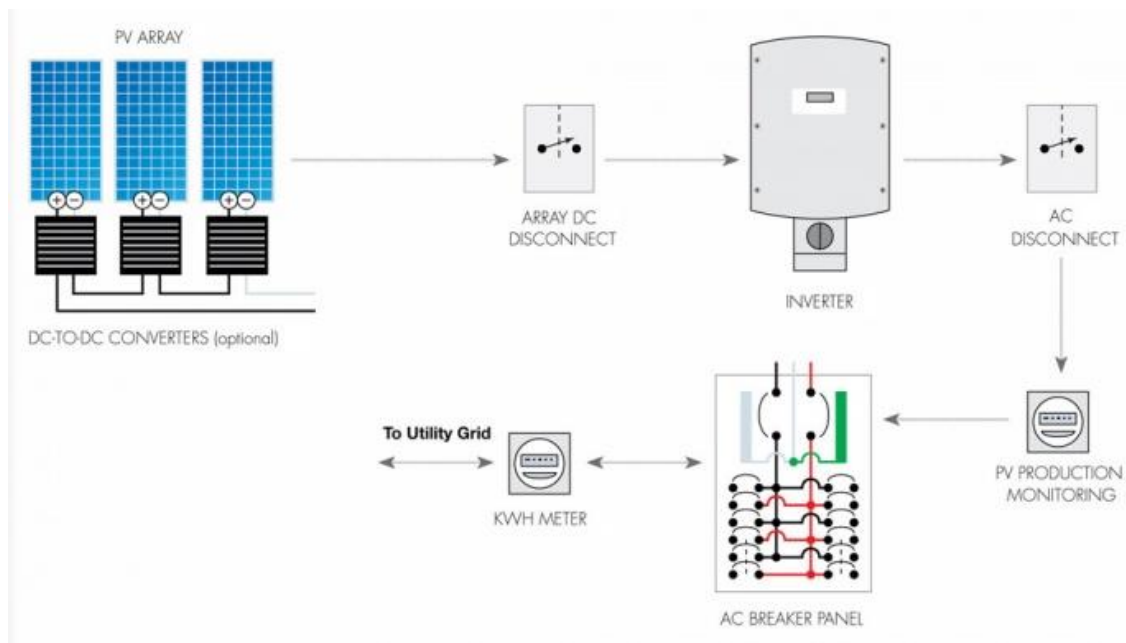

Figure 4.4.4 - Diagram for a battery-less grid-tied solar system

The diagram also shows a DC and AC disconnect switch where the system can be disconnected from power. This is also an NEC requirement and it is so that any necessary maintenance or repair jobs can safely be worked on. NEC section 690 also states that this DC disconnect must be within six feet of the combiner box and while it can be operated remotely, it must also have the ability to be manually disconnected. An example of a typically layout for these components is shown in Figure 4.4.5 below.

NEC requirements also specify what the ratings of the disconnects must be. DC current rating must be no less than 125% of the short circuit current from the parallel-connected modules. For example, a DC disconnect switch for a PV array consisting of 20 parallel connected PV strings each consisting of 30 series-connected PV modules must be rated for at least 125% of the short circuit current of one panel times 20. DC disconnects also tend to be much more expensive than a similarly rated AC disconnect. This is because while AC current goes to zero multiple times a second, making an arc easier to terminate, DC current flows continuously, creating a much stronger arc that requires more extensive measures to quench.



Figure 4.4.5 - Example of the components in a battery-less grid-tied solar system

4.5 Maximum Power Point Tracking/Charge Controller

4.5.1 MPPT

A maximum power point tracker is an electronic device that varies its load impedance in order to maximize the power output of the solar panels. Solar cells have non-linear output characteristics which are typically shown on an I-V curve graph, an example is in Figure 4.4.2 shown below.

Current-Voltage & Power-Voltage Curve(230-20)

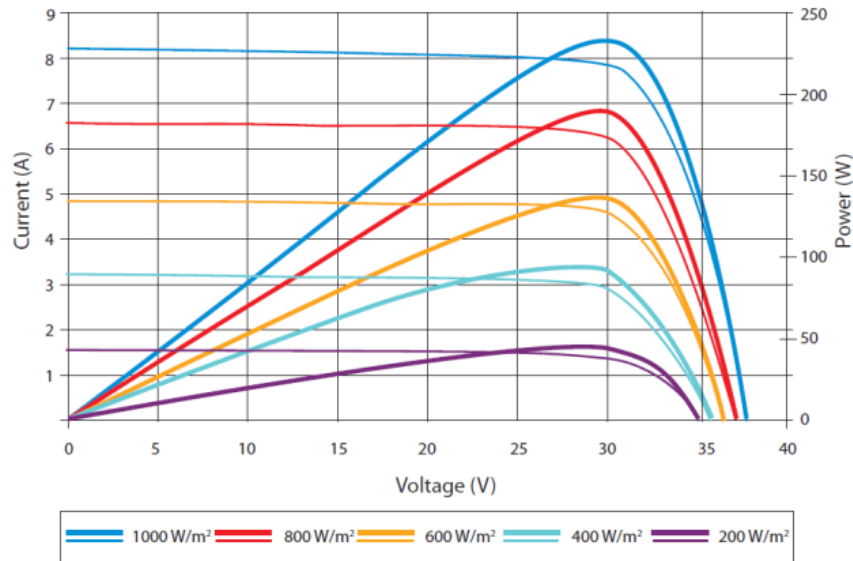

Figure 4.4.2 - I-V Characteristics of a Suntech STP230 solar panel at different conditions

The maximum power point of a solar panel lies at the knee of the I-V curve. The sample panel shown above has a V_{MP} (maximum power voltage) of 29.8V and I_{MP} of 7.72A under the standard 1000 W/m². The graph shows that the voltage variation is much less compared to the current variation under differing irradiance. The panel has an internal resistance that changes with solar intensity so if a static load is connected directly to a panel and its resistance is higher or lower than the panel's, the power drawn will be less than the maximum available.

There are several algorithms that can be used to achieve maximum power point tracking. The simplest of them all is the constant voltage method. This method uses a single voltage to represent V_{MP} and is usually programmed by an external resistor that can be part of a network that includes a NTC thermistor so the value can be temperature compensated. Sources give this method an overall rating of about 80% which means that under differing irradiance variations, the method will collect about 80% of maximum power.

Another method is the open circuit voltage method in which V_{OC} is used to calculate V_{MP} according to the equation:

$$V_{MP} = k * V_{OC}$$

K is typically a value between 0.7 and 0.8 and accounts for the small drop in V_{MP} that can be seen in the above graph as the irradiance drops. The short circuit current method is a very similar method that uses I_{SC} to estimate I_{MP} instead. It

uses a short load pulse to generate a short circuit condition where the voltage goes to zero.

A fourth method is called perturb and observe. Here the voltage or current of the panel is decreased or increased while monitoring the change in the power output. The direction of the change is reversed when the panel power decreases. Proper step size is an important consideration in this method because too large a step will result in oscillation about the maximum power point and too small a step will result in a slow response to changes in irradiance. Averaging the panel power value can help reduce the response to noise. One last method to be considered is called the incremental conductance method which locates the maximum power point when:

$$dI_{PV}/dV_{PV} + I_{PV}/V_{PV} = 0$$

Or when the instantaneous conductance is equal to the negative of the incremental conductance. The circuitry required to implement this algorithm is more complex and it is well suited for conditions of rapidly varying irradiance.

When cells are arranged in a series, the iterative methods can be better method since partial or differing angles of incidence can make it so you have to search for V_{MP} . But for whatever method is chosen, it is better to be accurate than fast since fast methods tend to bounce around the maximum power point due to noise in the power system.

Solar inverters tend to have an on-board MPPT that already maximizes the power coming in from the panels. In considering inverters for the full-scale sculpture we will need to have this. For our prototype we should plan on making our own MPPT board, since we do not plan on purchasing an inverter for our model.

4.5.2 Charge Controller and Battery

A charge controller is a device that can safely and efficiently charge a battery. Most 12V panels actually output around 17V under ideal conditions. The reason for this is so that a 12V battery can still be charged when the sun is low in the sky or conditions are not ideal. The charge controller regulates the output down so that the battery is not damaged. Its job is similar to that of the MPPT and many companies make controllers that will integrate an MPPT algorithm already.

Because one of the goals of the project is to minimize the maintenance that will need to go into the sculpture and also to make it as safe as possible, the full-scale structure will not have a battery and therefore not need a charge controller.

However, we will have a battery to power our prototype since we cannot actually feed the electricity onto the grid at UCF and we still have to power our own electronics.

There are many kinds of batteries we can consider for use in our prototype. The most common rechargeable batteries that are used today are nickel cadmium, nickel-metal hydride, lead acid, lithium polymer, and lithium ion polymer.

Nickel cadmium (NiCd) batteries are a mature technology that has long life, high discharge rate and an economical price. However, they are relatively low in energy density and they contain toxic materials that are environmentally unfriendly. They are also one of the most rugged rechargeable batteries.

Nickel-metal hydride (NiMH) batteries have 30-40% higher energy density than do NiCd ones and they contain no toxic metals. This comes at a reduced cycle life and a more complex charge algorithm since it generates more heat while charging. They also require regular full discharges and are about 20% more expensive than NiCd.

Lead acid batteries are the most economical for large power systems where weight is not a big concern. They are also low maintenance and capable of high discharge rates but have a low energy density, limited number of discharge cycles, and are environmentally unfriendly.

Lithium ion batteries are high energy and lightweight. They are also low maintenance since they do not require periodic discharges but they do, however, need a protection circuit that limits voltage and current and can be subject to capacity deterioration over time. They are also expensive to manufacture, costing about 40% more than NiCd technology.

Lithium polymer is the least developed of the technologies but these kind of batteries also have the smallest profile. They can be manufactured to resemble the thickness of a credit card and are lightweight. However, they are still expensive to manufacture and do not yet offer many improvements on a typical Li-ion battery. Their main advantage is their small form factor.

For our project we decided to use lithium-ion batteries since there are inexpensive options available and they are energy dense. Most of these kinds of batteries come with charging protection circuits built in to prevent them from exploding but they also require the user to follow an intricate charging process that includes five steps.

Pre-conditioning must happen when a battery has been depleted to the point that its cells essentially die. The battery has been allowed to discharge too much and

its voltage has dropped significantly below its rated voltage. During pre-conditioning, the charge current is limited until the battery reaches a minimum voltage and it can withstand all of the current in the constant current phase. The cells must be rejuvenated before they can begin to be fully charged.

Next comes the constant current phase in which the battery can be charged at its maximum rate until it reaches its rated voltage. In this phase, it can be advantageous to charge the battery at a slower rate. This is because if it is charged at a slower rate, it will be more likely to reach 100% capacity when it hits rated voltage, otherwise, it may reach this voltage while still below max capacity.

After constant-current comes constant-voltage. Here, the current steadily decreases while the voltage is kept constant in order to prevent overcharging. While still below full capacity, the charging is terminated and moves into the last phase which is called charge top-up. Because the battery can discharge itself naturally over time, that top-up phase waits until it falls to a specified voltage, then charges it back up to rated voltage.

4.5.3 Product Comparison

For our MPPT/charge controller, we considered two components that could potentially be used in our prototype, shown below in Table 4.4.1. Both are compatible with Li-ion technology batteries and both have integrated maximum power point tracking algorithms based on the constant voltage method.

<i>Manufacturer</i>	<i>Texas Instruments</i>	<i>Linear Technology</i>
<i>Part Number</i>	BQ24650	LT3652
<i>Price</i>	\$5.65	\$6.53
<i>Input Voltage</i>	5V – 28V	4.95V – 32V
<i>MPPT Algorithm</i>	Constant Voltage	Constant Voltage
<i>Max Charge Current</i>	10A	2A
<i>Battery charging compatibility</i>	Li-ion/polymer, LiFePO ₄ , Lead Acid	Li-ion/polymer, LiFePO ₄ , Lead Acid
<i>Package</i>	VQFN-16	MSOP-12 or DFN-12

Table 4.4.1 – Battery Comparison

Both IC's would likely work for our design. The disadvantage of the TI part is that it only comes in a VQFN-16 package which is difficult to hand-solder and so difficult to prototype with. However, it also supports a larger charge current. The LT IC would be easier to hand-solder onto a breakout board so that we could prototype on a breadboard.

4.6 Voltage Regulators

Our project has several subsystems that will operate under different voltages. Our battery will provide only one specific voltage. We must therefore use voltage regulators to step this DC voltage down to meet the requirements of the rest of our components. Here we will discuss two main types of voltage regulators: linear and switching voltage regulators.

Linear Voltage Regulators are the simpler and less expensive of the two types that will be discussed. They are used mainly in low power applications because they work on the principle that any excess power is dissipated as heat by the regulator. This makes them very inefficient and if a substantial amount of power is dissipated through it a heat sink must be added else risk thermal failure of components in and around the regulator. Another issue with linear regulators is that they require a minimum input voltage above the regulated output voltage. This is generally referred to as the dropout voltage and is typically around 2V, though it can be smaller.

This kind of regulation can be implemented through something as simple as a resistor divider circuit or a Zener diode operating in its breakdown region. In both, the power out is significantly less than the power in.

Switching Voltage Regulators are generally a better option as they are typically much more efficient than linear ones. Because they are more efficient, they dissipate a lot less heat and smaller heat sinks can then be used to make them much smaller than a similar linear regulator. However, they do require storage elements like inductors and capacitors. They also both step up (boost) and step down (buck) DC voltages.

Switching regulators require a switch to work. This switch will usually be controlled by a pulse width modulator that will periodically turn on and off so as to allow energy from the input to go to the output. Whenever the switch is turned off, the storage elements pick up the slack to maintain the output voltage. Because the input current must be periodically turned on and off, these can sometimes not be the best option for the regulation of solar panels. Maximum power point tracking requires a continuous current to maximize power. Since we will be connecting the regulator to the batteries, though, and not the solar panels, this should not be an issue.

Another disadvantage of switching regulators is the fact that they induce transient ripples. These ripples can very easily damage other components in fractions of a

millisecond. The transients also create harmonics that can distort the output and lower the efficiency of the regulators.

We will use TI's Webench Designer Power Architect to pick out our regulators. It is an online tool that allows users to design, simulate, and optimize a complete power supply system for different outputs.

4.7 Light Sensor

4.7.1 Overview of Light Sensor

Our solar tracker design will need a means of determining the sun position. The addition of the light sensor in our design provides this means. Before we discuss different light sensor and which may be best for this project we must first understand what we are trying to sense. In this case, we are using the sensor to track the sun; we need a sensor who can detect the sun's light and the intensity of that light detected. The sun's light is generally broken into three components, visible light (wavelength of 400 - 800nm), ultraviolet light (wavelength of < 400nm), and infrared radiation (wavelength of > 800nm). We want the sensor to detect sunlight for as long as the sun is in visible range to the tracker. Figure 4.7.1, shown below, displays the spectral power of different sunlight component wavelengths in different conditions. We can see in the 400 – 450nm range intensity becomes high compared to the shorter wavelengths. The intensity climbs a little in the wavelengths > 500nm. With the orange and yellow data sets we see the greatest intensity happens at about 700nm. Ultimately this graph tells us that our sensor's wavelength range should be about 400 - 750nm.

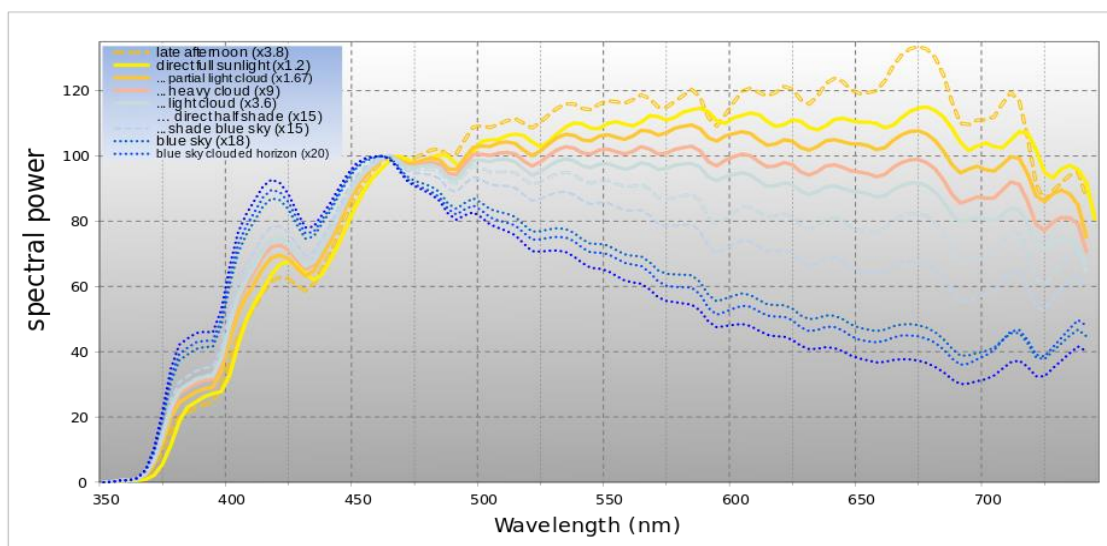

Figure 4.7.1 - Spectral Power vs. Wavelength

4.7.2 Classifications of Light Sensors

A light sensor is a passive sensor that indicates intensity of light by examining the radiant energy that exists in certain frequency ranges. There are a couple of classification of photo sensors, for the purpose of our project I'm going to focus on two of them, photo conductive cells and photo junction diodes.

Photo Conductive Cells is a type of photo device that changes its resistivity based on the intensity of light exposed to the device. These types of photo devices change photoconductivity based on light intensity hitting the device which controls the current flowing in the device for a given voltage. The relation between current and light intensity in this device is proportional.

Photo Junction Diodes is a semiconductor photo device that controls the flow of electrons or holes across the junctions using light. These devices are specifically designed for detector applications.

4.7.3 Types of Light Sensors

Within these classifications, I'm going to focus on comparing three types of sensors, photo-resistor, photodiode, and phototransistor. These sensors are the most commonly used types of light sensors.

Photo-Resistor is a common type of photoconductive device. The Light Dependent Resistor (LDR) a type of photo-resistor is the most common photoconductive cell. The device acts like a variable resistor that changes due to light intensity, this implies the current and resistance (which represents intensity in this device) is linear. Common materials for this device include cadmium sulfide (CdS) and lead sulfide (PbS). Photo-resistors made with CdS are sensitive to near infrared and visible light; it also has a response curve very similar to the human eye's response. The sensitive wave length of CdS peaks at about 560 to 600nm in the visible spectrum range. Figure 4.7.2, shown below, displays resistance at given light intensity values. The current value largely depends on the set voltage for the sensor circuit meaning we can control the current value to make it easier for the microcontroller to detect changes in light intensity. However, for our application our lighting will mostly sit in between the yellow and green portions of the graph, we can see that as light intensity increases the change in resistance becomes very small, this decreases the accuracy of our sensor to track the exact location of the sun.

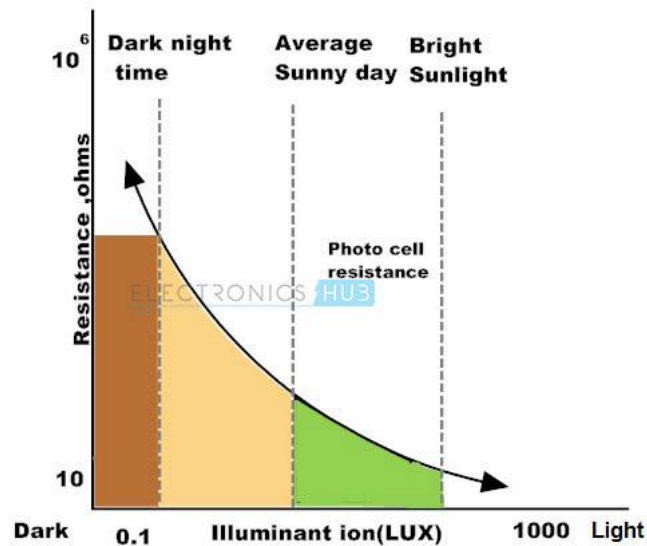

Figure 4.7.2 - Resistance vs. Light Intensity

Photodiode is a photo junction device made from semiconductor PN junctions. These devices are sensitive to visible and infrared light; when light is detected the electrons and holes are separated and allow the junction to conduct. The amount of current that passes through the photodiode is proportional to the amount of illumination of the junction. Figure 4.7.3, shown below, shows the current flowing in the diode vs. the applied voltage. We can see from the graph that the current doesn't change with the collector-emitter voltage once it reaches a given turn on voltage; also the difference between current values at two different yet very close light intensities is easy to measure which increase the accuracy of the sensor's sun tracking ability.

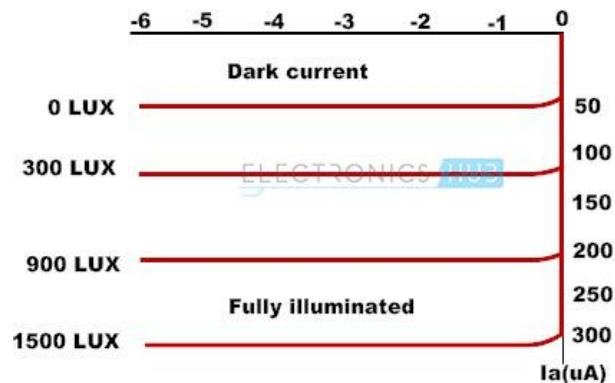

Figure 4.7.3 - Current vs. V_{CE}

Phototransistor is a photo junction device, that basically combines a photodiode and an amplification transistor. The collector-base junction in reverse bias acts as a photo diode. The current produced at the collector-base junction is amplified by the transistor producing a large collector current; the currents in the phototransistor are 50 -100 times that in the photodiode. Some phototransistors allow the base to be connected which can be used to control the sensitivity of the phototransistor. Figure 4.7.4, shown below, shows the relationship between the collector-emitter voltage, light intensity, and current in the collector. The graph once again shown the current is not dependent on the collector-emitter voltage. The slope of the lines seems to be less sharp then that of the photodiode, meaning it takes more voltage to achieve the constant current. Once again the difference of current for two light intensities with little change is larger than that of the photo-resistor.

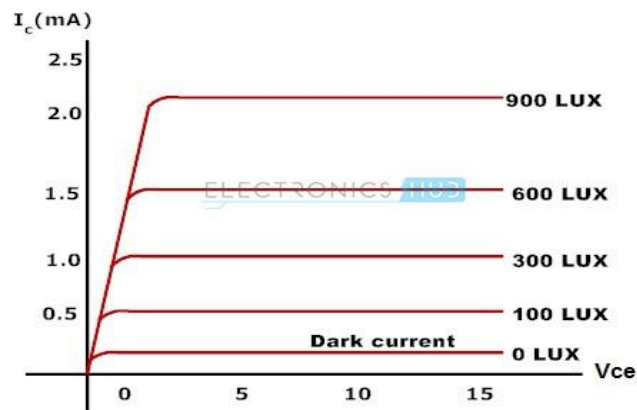

Figure 4.7.4 - Phototransistor I_C vs. V_{CE}

After detailing the three most commonly used light sensor devices above, we must now consider which devices is best for application. Table 4.7.1, shown below, compares the devices using some key properties we should consider. Looking at the table we see the phototransistor and the photodiode have positive scores in a lot of the key properties. Looking further into those two we can once again narrow the choice, the phototransistor seems to have the best marks on some of the most important key properties for this project such as ruggedness, cost, and performance-to-cost ratio; also when considering the measurement of change in intensity, the phototransistor has larger current which increases the sensor's accuracy.

Electrical Characteristic	Photodiode	Phototransistor	Photoconductor	CdS Photocell
<i>Wavelength (μm)</i>	0.2 – 2.0	0.4 – 1.1	2-15	0.4-0.7
<i>Performance-to-cost ratio</i>	Good	Excellent	Fair	Excellent
<i>Sensitivity</i>	Very Good	Very Good	Very Good	Very Good
<i>Linearity</i>	Excellent	Good	Good	Good
<i>Dynamic Range</i>	Excellent	Very Good	Good	Good
<i>Stability</i>	Very Good	Good	Fair	Poor
<i>Cost</i>	Low	Very Low	High	Very Low
<i>Ruggedness</i>	Excellent	Excellent	Good	Excellent
<i>Size</i>	Small	Small	Small	Small

Table 4.7.1 - Photo Sensor Comparison

4.7.4 Product Comparison

Now that we have chosen our type of light sensor, we need to compare available products on the market. Table 4.7.2, shown below, shows some important characteristics and some available products. Our sensor needs to have a range of wavelengths similar to the range in Figure LS1, 350 – 750nm. For the maximum temperature the higher the better since it will be operating in direct sunlight. We also want the packaging to be easy to solder or attach to the rest of the system and the price to be relatively low. Comparing the three products below with respect to the above mentioned sensor needs, we find the best sensor to be Adafruit 2831.

<i>Characteristics</i>	TI OPT3001	Adafruit 2831	Jameco 373001
Type	Phototransistor	Phototransistor	Phototransistor
Wavelength (ηm)	460 - 655	480 - 1050	500 - 1200
Supply Range (Nom V)	1.6 – 3.6	3 - 15	0.3 - 5
Collector Current	2 – 3.5 μA	50 - 70 μA	0.6 – 2.0 mA
Max Temperature ($^{\circ}C$)	85	90	85
Packaging	SON	Through Hole	Through Hole
Price	\$2.77	\$0.95	\$0.35

Table 4.7.2 - Product Comparison

4.8 Current Sensor

4.8.1 Types of Current Sensors

For our design we need to measure power generated by the solar tracker; to achieve this we need to include a current sensor. There are two main types of current sensors, closed-loop sensors and open-loop sensors.

Closed-loop Sensor can measure both AC and DC current and provides electrical isolation. Some benefits of this type sensor include fast response, high linearity, low temperature drift, and low sensitivity to electrical noise. The sensor output is easily converted to voltage. The closed-loop sensor is often chosen for applications requiring high accuracy and they are most commonly used in commercial and industrial applications.

Open-loop Sensor is a hall sensor mounted in the air gap of a magnetic core, with a conductor running through the core. The conductor will produce a magnetic field comparable to the current running through the conductor. The signal from the hall sensor is very low so it must be amplified, which is generally included in the sensor. This type of sensor normally includes temperature compensation and calibrated high-level voltage circuitry. The open-loop sensor is susceptible to saturation and temperature drift. This type of sensor has a price advantage in the high current range of 100A and above; they are also smallest in size and weight. The sensor also maintains constant power consumption regardless of the current sensed but they are best for applications with restricted temperature variation.

4.8.2 Product Comparison

Consider the details above about the two different types of current sensor, we find that the best sensor type for our application is the open-loop because of its cost advantage and its small size. Now that we have chosen the type of sensor we should use we need to find products on the market that fit our application and needs. In Table 4.8.1, we compare the products we found based on some key characteristics. Using the table below, we choose the Allegro ACS711KLCTR-12AB-T because the maximum temperature and sensitivity is the best of the three. This product also has a high maximum temperature and its maximum current sensing is large enough to accommodate the MPPT current.

<i>Characteristics</i>	Allegro ASC711EEXLT- 15AB-T	Allegro ACS711KLCTR- 12AB-T	Allegro ACS711ELCTR- 25AB-T
<i>Max Current Input (A)</i>	15.5	12	25
<i>Supply Range (V)</i>	3 – 5.5	3 – 5.5	3 – 5.5
<i>Sensitivity (mV/A)</i>	90	110	55
<i>Max Temperature (°C)</i>	85	125	85
<i>Packaging</i>	QFN	SOIC	SOIC
<i>Price</i>	\$1.17	\$2.15	\$1.18

Table 4.8.1 - Current Sensor Product Comparison

4.9 Motors

4.2.1 Overview and Types of Control Motors

Implementing solar tracking for our electronics will require some type of motion control in order to orient the solar panels to achieve maximum power efficiency. Motors are a very important part for the movement of our solar panels and, as a group, we will consider three different types of motors for our design: DC, servo, and stepper motors. We will compare the features of these motors to our

requirements specifications in Section 2.0 to determine which type of motor will best meet our requirements.

To start, we will discuss direct current motors (DC motors). DC motors were very widely popular since they used DC current to be powered and operates on the principles of electromagnetism. The fundamental idea of DC motors is as follows. A current is run through a closed loop conductor that is placed within a magnetic field, produced by two opposite poles. As current runs through the conductor, the magnetic field produces two sets of forces on the conductor: one set of forces is perpendicular to the current and magnetic field vectors and the other set of forces is also perpendicular to the current and magnetic field vectors but act in the opposite direction to the first set of forces. The direction of the forces is due to the direction of the current, which is travels away from the power source and then loops around and travels back to the power source. These forces, known as the Lorentz force, effectively produces a couple moment that serves to produce purely rotational motion that then starts to rotate the conductor. Depending on the direction of the current through the conductor, the direction of rotation will also change. The above idea is shown below:

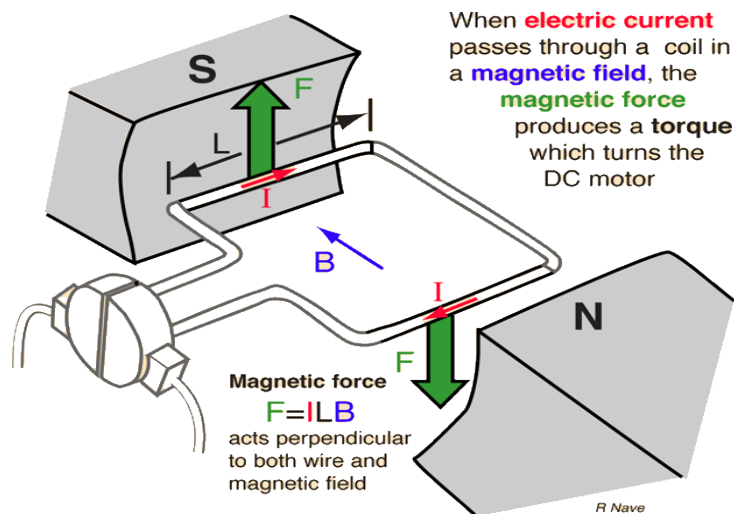

Figure 4.9.1 – Electromagnetism Principle of DC Motors

To conclude the discussion of DC motors, we would like to take a look at two specific types of DC motors: Brushed and Brushless DC motors. Brushed DC motors are made up of four specific parts: the stator, rotor, brushes, and the commutator. The stator surrounds the rotor and produces a stationary magnetic field, where the rotor will be rotating. The rotor consists of windings that are energized, which will allow them to rotate within the stator. On the axle of the rotor lies the commutator, which are two segments of copper coating that surrounds the axle of the rotor with gaps between them. Finally, the brushes are what is in contact

with the commutator and are charged by a power source. When the rotor rotates, the commutator is in constant contact with the brushes until it encounters the gap, where the switching in polarity occurs in the winding. This causes the rotor to rotate within the stator, thus producing the rotational motion for the motor. Since the brushes and commutator are in constant contact, they tend to wear out easily, and thus leads to high maintenance costs as a result of replacing the brushes and the commutator. Brushless DC motors work in almost the same manner; however, it operates without the use of brushes or a commutator. The rotor is a permanent magnet that rotates around the stator. The stator contains three pairs of windings in a certain arrangement and it surrounds the stator. The windings have current running through them in sequence: one winding is supplied with current, which rotates the rotor. Once the rotor reaches the energized winding, the next winding is supplied with current, which pulls the rotor towards the next winding. This pattern happens continuously to rotate the rotor, thus producing the desired rotational motion of the motor. A figure that shows the operation of the brushless DC motor is shown below:

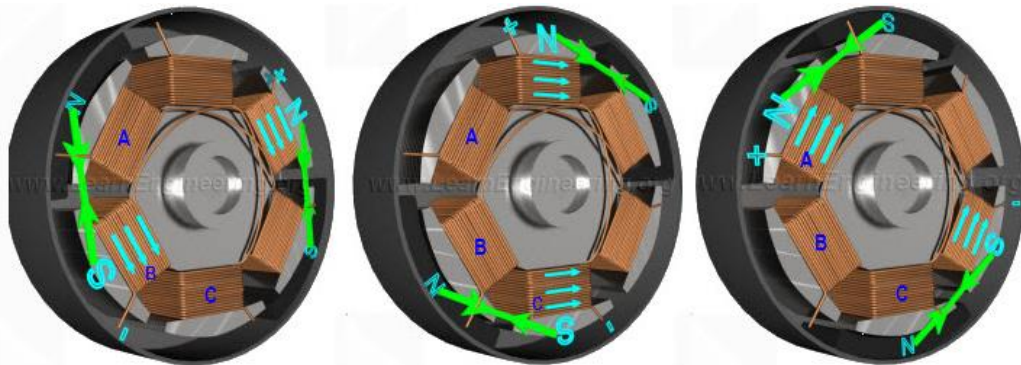

Figure 4.9.2 – Operation of a Brushless Motor

As a result of no contact between the windings and the rotor, this gives us a highly reliable and consistent motor that can run for long periods of time without wear. Between the two types of motors, the brushless DC motor seems to be an excellent choice thus far since it requires little maintenance.

The next type of motor is the servo motor. These motors tend to be very small and are used in small applications such as toys or any type of device that requires movement; having said that, these motors have also been used for industrial uses, in areas like medicine. On the outside of the servo motor, you have a few gears that are rotate. On the inside of the servo motor there are three components: A DC motor, a potentiometer, and a control circuit. The potentiometer in the servo acts as a variable resistor, that sends information to the control circuit about the movement of the servo motor as the dc motor rotates the gears. Servo motors also use proportional control to control the amount of movement: The larger the

distance between the actual and desired locations, the faster the rotation and the smaller the distance between the actual and desired locations, the slower the rotation. This fact makes these types of motors very efficient in that they only work as hard as they need to work. Lastly, the motor can rotate 180 degrees on a single axis: The direction that the motor rotates is controlled by pulse width modulation, or PWM. To clarify, a pulse of some length of time is sent repeatedly to the motor in order to rotate it either clockwise or counterclockwise. The width of this required signal varies between servos and will be an important factor to consider.

Lastly, we will discuss the stepper motor for consideration. The stepper motor is an open loop motor that takes about 200 steps per rotation, which translates to a 1.8-degree rotation per 200 steps. This allows for very precise movement. In addition, the motor is also brushless which, in our analysis of DC motors, we were able to see that brushless motors generally had a longer life and less maintenance than motors that used brushes to switch the current. From here, let us analyze three types of stepper motors: permanent magnet, variable reluctance, and hybrid stepper motors. For simplicity, we will explain the concepts of the motors without applying technical details for specific motors. We will leave that to Section 4.9.2.

The first type of stepper motor is permanent magnet stepper magnet. This motor consists of a rotor, which is a permanent magnet, surrounded by the stator which has an arrangement of windings surrounding the rotor. This type of motor works in much the same way as a DC motor: The windings are energized in a pattern and the polarity that this creates causes the rotor to rotate. The next type of stepper motor is a variable reluctance stepper motor. In a variable reluctance stepper motor and in this type of motor, the rotor is made of non-magnetized soft iron and is also toothed. When the windings of the stator are energized, one set of teeth on the rotor are aligned with the energized winding of the stator. To rotate the rotor, the windings are energized one after another, each time aligning the teeth of the rotor with the energized stator, thus rotating the rotor. Lastly, we have the hybrid stepper motor, which is a combination of the permanent magnet and variable reluctance stepper motors. In this type of motor, the rotor is a permanent magnet separated into two sections: one section is magnetized with south polarity, and the other is magnetized with north polarity. Also, both sections are toothed as well as the stator. The stator then contains windings that are activated in two pairs: one pair of windings is energized to act as north poles and the other pair of windings act as south poles. As a result, a minimum of eight windings are needed on the stator to produce rotation. During each step, four windings are activated: the two windings producing south poles align with the north pole rotor teeth and the two windings producing north poles are aligned with the south pole rotor teeth. Then the next set of windings are activated, which then realigns the teeth, thus producing rotation. This pattern of energizing the windings continues to produce a continuous rotation. Below is Figure 4.9.3 showing each type of stepper motor for clarification.

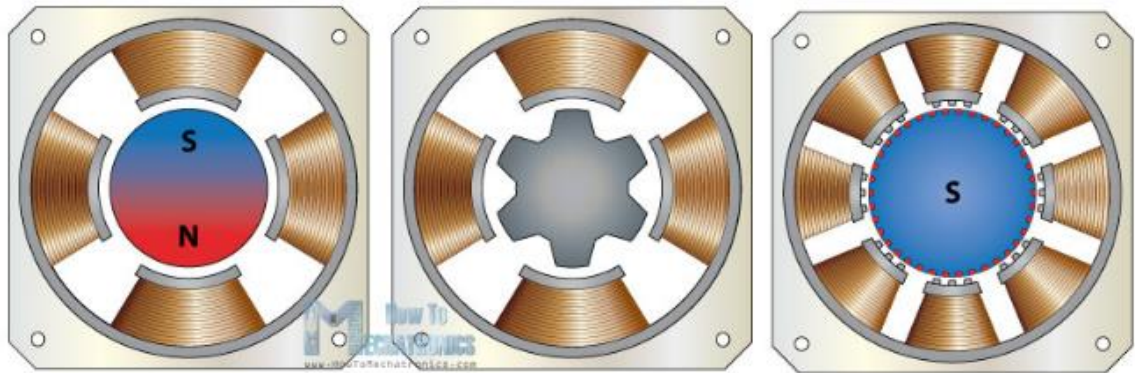

Figure 4.9.3 Comparison of Stepper Motor Types. From left to right: Permanent Magnet, Variable Reluctance, and Hybrid.

Lastly, in our discussion of stepper motors, it will be useful to discuss the different drive types available for stepper motor control, which will determine how the rotor rotates. There are four different types of drive types: Wave drive, full step drive, half step drive, and micro-stepping. To explain, let's use the permanent magnet stepper motor with four windings as shown on the figure below. Also, a step will refer to a single rotation and resolution is proportional with the number of steps necessary to complete a full rotation (i.e. a higher resolution corresponds with a higher number of steps needed to complete a full rotation). With wave drive, one winding is active at a time, so the rotor will rotate a full 90 degrees when a winding is activated, thus completing a full rotation for every four windings that are activated. With full step drive, two windings are active at a time. This, in turn, produces more torque, since a greater magnetic force is exerted on the rotor, but the resolution is the same of the wave drive, with a complete rotation being completed in four steps. In half step drive, the windings are activated in a 1-2-1 pattern. What this means is that one winding has current running through it, followed by two windings, followed by one winding, and this continues on. The advantage of this drive is that the rotor rotates 45 degrees for each rotation, thus increasing the resolution since 8 steps are needed for a full rotation as opposed to 4 steps. Lastly, there is micro-stepping. This involves varying the current in the windings in order to produce a continuous motion that is very desirable for precise movement.

4.2.2 Motor Product Comparisons

The motor that we will use will be based on a number of different factors. The requirements for the motor are explained in detail in section 2.3.7 and will be the basis for the motor selection. To explain a few, a high torque rating will be required for our design, both for the full-scale deliverable and for the 1/8th scale deliverable.

In addition, the motors should weigh very little (less than 2 pounds per motor) and be able to be controlled with the group's control unit of choice. For this comparison, we have decided to limit our choices to a group of stepper motors. DC motors and servo motors are very well suited for systems that require very high revolutions per minute (RPM). Also, with servo motors, a high torque rating can be maintained at higher speeds. With both the full-scale and 1/8th scale designs, the motors will not be moving very fast, since the motors will run in order to follow the path of the sun. Stepper motors provide us with several benefits: they tend to be quite inexpensive, the torque rating is at maximum at low speeds, which is very suitable for our designs, and these motors are made for open-loop operation, which requires no feedback from the environment. The use of sensor data can be used to determine how to move our design without referring to previous sensor data. Table 4.9.1 shown below shows different stepper motors and several key features are presented.

	324 Adafruit Nema 17	Nema 14 14HS17-0504S	Inventables 25253-01 Nema 17
Operating Voltage (Volts)	12	7.5	2.8
Steps per Revolution	200	200	200
Degrees per Revolution	1.8	1.8	1.8
Number of Leads	4	4	4
Amperage (Amps per Phase)	0.35	0.5	1.68
Holding Torque (Ounce-Force Inches per Phase)	28	32.6	62
Resistance (Ohms per Winding)	35	15	1.65
Weight (kg)	0.22	0.22	0.35

Table 4.9.1 – Motor Comparison

For the full-scale design, it would be desirable to have a motor with as much holding torque as possible. We have considered two motors for the full-scale design: The 324 Adafruit motor and the Inventables motor. Both of these motors have a good amount of holding torque. The most noticeable difference between the two motors is the rated voltage. The Inventables motor is rated at an operating voltage of 2.8 Volts and draws 1.8 Amps per phase when powered with 2.8 Volts as opposed to the Adafruit motor that is rated at 12 Volts and draws 350 milli-amps per phase when powered with 12 Volts. Also, stepper motors can run at voltages much higher than their rated voltages, although at the cost of generating more heat due to drawing an increased amount of current. This can be prevented by using a

stepper motor driver. A stepper motor driver is used to control the amount of current going to the motor and to provide the proper order of energizing the windings in order to control the motor. For the 1/8th scale design, we have decided that the Pololu SOYO motor will be able to provide the motion required for our solar tracker. For this design, we will be using a battery, charged by the solar panels, to provide power to our motors. These batteries will be designed to output at least 7.4 Volts for the motor. In addition, we will also require the use of a stepper motor driver in order to provide the proper sequence of current to the windings to rotate the rotor. Since the use of a stepper motor driver is required for both the full-scale design and the 1/8th scale design, it will be beneficial to discuss the drivers.

4.2.3 Stepper Motor Driver Comparisons

A stepper motor driver is a device that will take in a control signal as an input (in our case, the control signal will come from the MCU) and will provide the proper sequence of current to power the motor as a result of receiving that control signal. Also, stepper motor drivers usually have other benefits, such as amperage control, so that we can run the motor at a higher voltage than rated without damaging the motor. In some cases, this increases the efficiency of the motor. The three stepper motor drivers that we will consider are the following: The TI L293D, the ROB-12779 ROHS EasyDriver, and the Allegro A4988. The L293D is a stepper motor driver that is a quadruple high-current half-H drivers with a maximum voltage of 36 V, currents of up to 600 mA, and comes in a 16 pin DIP package for easy integration into a printed circuit board. Each of these boards can drive one 4-wire stepper motor. The ROB-12779 ROHS EasyDriver is a breakout board for the Allegro A3967 stepper motor driver and features adjustable current control (from 150 mA per phase up to 700 mA per phase), can be powered by voltages between 6V and 30V, wide control of microstepping resolution, and can be used to power bi-polar stepper motors of 4, 6, and 8 wires. Lastly, the Allegro A4988 is a stepper motor driver that can be powered by voltages between 8V and 35V, can deliver 1 A per phase without cooling (2A with cooling), supports different microstepping resolutions (down to about 1/16th), and supports adjustable current control through the use of a potentiometer. The stepper motor driver can be used to drive bi-polar motors. After reviewing the three drivers, we have concluded that the ROB-12779 ROHS driver is the most suitable driver for our needs. Using this driver, we have easy current control so that we can safely control the motor without worrying about the voltage that will be used. Also, with the control from before, we can use higher rated voltages, which will increase the holding torque of the motor. This will make our motors very reliable and these motors can be controlled using the Arduino libraries so the use of a control unit able to be programmed with the Arduino IDE is very much desired. Below in Table 4.2.4 we highlight the features of all of the drivers.

	Texas Instruments L293D	Sparkfun ROB - 12779	Allegro A4988
Cost	\$1.58	\$14.95	\$5.95
Operating Voltage (Volts)	Up to 36	0 - 30	8 - 35
Output current (Amperes)	600	± 0.750	1
Operating Temperature (Celsius)	0 - 70	-20 - 85	-20 - 85

Table 4.2.4 – Motor Comparison

4.10 Wireless Data Communication

One of the solar sculpture’s functional requirements is to publicly display the amount of energy harvested from the sun in a way that people with no technical background can easily understand it. We decided that displaying this information on a website would be the best option because of its ease of accessibility. We decided to use a website instead of a smartphone app because it doesn’t require the extra steps for the user to download and install something. Additionally, an app would have been costly to implement since the project would require the creating of both IOS and Android apps in order to reach a broader audience. Now, the microcontroller inside the sculpture will need to send this information to a server so it can be displayed on a web application. This is a design approach widely used by our contemporaries and it is called the Internet of Things or IoT. The IoT is a network of low-power devices that sense data and communicate information without human intervention. There’s different technologies that allow smart objects to connect to the internet and the cloud. The best one will depend on the technology constraints and the variety of hardware and software integration requirements. In the next paragraphs, we will compare the two most popular technologies used for IoT devices, Bluetooth and Wi-Fi. We will also discuss their advantages and disadvantages for our solar sculpture. Figure 4.10.1 explains the pathway of data transmitted over Wi-Fi and Bluetooth connections.

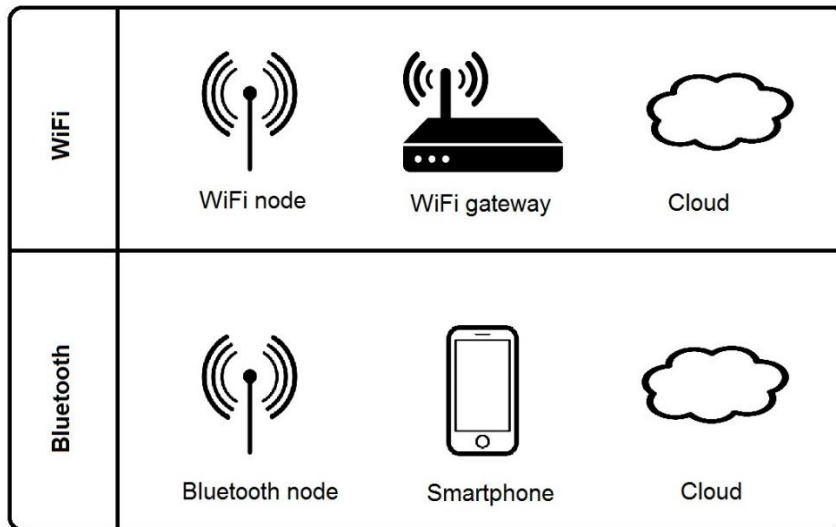

Figure 4.10.1 - Wireless Communication Structure

Wi-Fi is a technology that lets electronics connect to a wireless local area network (WLAN) via a wireless access point (or hotspot) which has a range of 20 meters (66 feet) indoors and a longer range outdoors. The development of this technology gave people the option of having internet access in places where cables couldn't be run such as historical building or outdoor areas. Wi-Fi Protected Access encryption (WPA2) is a high quality security protocol used by Wi-Fi connections and it is considered secure, if a strong passphrase is used. Also, Wi-Fi natively offers TCP/IP protocols that today connect millions of devices around the globe. This makes Wi-Fi a good candidate technology for an IoT device.

Additionally, the organization responsible for Wi-Fi standards, The Wi-Fi Alliance announced this year the latest iteration of Wi-Fi technology: HaLow. This new technology promises to double the range of regular 2.4GHz Wi-Fi connections and do a better job transmitting its signal through walls, floors and other obstacles. Wi-Fi HaLow operates on the 900MHz band which is perfect for small data payloads and low-power devices. The obvious benefit of using Wi-Fi HaLow over Bluetooth, the connectivity technology most used for low-powered devices, is that Wi-Fi connects its devices straight to the internet instead of have to rely on another device for that connection. In conclusion, this new kind of Wi-Fi is specially designed for IoT devices such as smartwatches and security systems. Due to the novelty of the product and the low connectivity needs of our project we won't be using this new technology but it should be considered for the implementation of the actual model of the solar sculpture.

Bluetooth is a standard wireless technology that is used to send data over short distances. It can connect several devices, which resolves problems of

synchronization. Depending on the Bluetooth version, the range can vary. Version 5.0 has a maximum range of 243.84 meters (800 feet). The effective range fluctuates because of the propagation conditions, coverage of material, antenna configurations and condition of the battery. Its security features include confidentiality, authentications and key derivation which is usually based on a Bluetooth PIN, which has to be entered in both devices involved in the communication. Bluetooth also encompasses a similar technology called Bluetooth low energy (BLE), also marketed as Bluetooth Smart. BLE is aimed at new applications in the healthcare, fitness, security and home entertainment industries. It differs from classic Bluetooth in that it provides considerably reduced power consumption and cost while keeping a similar communication range.

Bluetooth technology has a new development as well: Bluetooth 5. Because of this new technical enhancements being launched in early 2017, it has been predicted that there'll be a bigger flow of IoT devices using Bluetooth technologies. The Bluetooth company posted on their website "In fact, Bluetooth will be integrated into an estimated one-third of all installed IoT devices by 2020." The improved features over the last version, Bluetooth 4.2, includes twice the transmission speed, 800% boost in broadcasting capacity and four times the range. This will create a new category of "smart" products and should definitely be considered for future projects.

The decision of choosing the type of wireless communication came down to the fact that uploading information to the cloud to display it on a website. This is why we chose Wi-Fi over Bluetooth. The way Bluetooth would have to be implemented is by adding a Bluetooth module to our microcontroller and send the information to a smartphone that it's connected to the internet either via a mobile phone carrier data provider or via Wi-Fi. Provided that a Bluetooth module and a Wi-Fi module are sold at very similar prices and that the sculpture will be in range of a Wi-Fi hotspot, we can rely our decision on the fact that we would need extra equipment (the smartphone) to implement the Bluetooth wireless communication. This also includes the fact that Bluetooth hardware consumes less power than Wi-Fi hardware but in the case of Bluetooth we would also have to power the smartphone device that interfaces the Bluetooth node and the cloud.

5.0 Project Hardware and Schematics

5.1 Initial Design Architecture and Related Diagrams

There are several differences between the full-scale design and the prototype. In the following sections, we will discuss the initial structure for both the full-scale and the prototype. Then, we will discuss the details of the three subsystems of the prototype; these subsystems are the power subsystem, the motion subsystem, and the wireless subsystem.

5.1.1 Full-Scale System Overview

The full-scale diagram is shown below in Figure 5.1.1; this diagram includes an unknown load which will be determined when the artist determine if they want lights, sound, or any other electronics when they begin design. It will feature four subsystems which are power, load, wireless, and motion. Most of this design is widely unknown in order to make the current design as flexible as possible for the artists to have the most creative control as possible. We based our prototype and the diagram below on a piece of the structure we know will stay stagnant, the solar power.

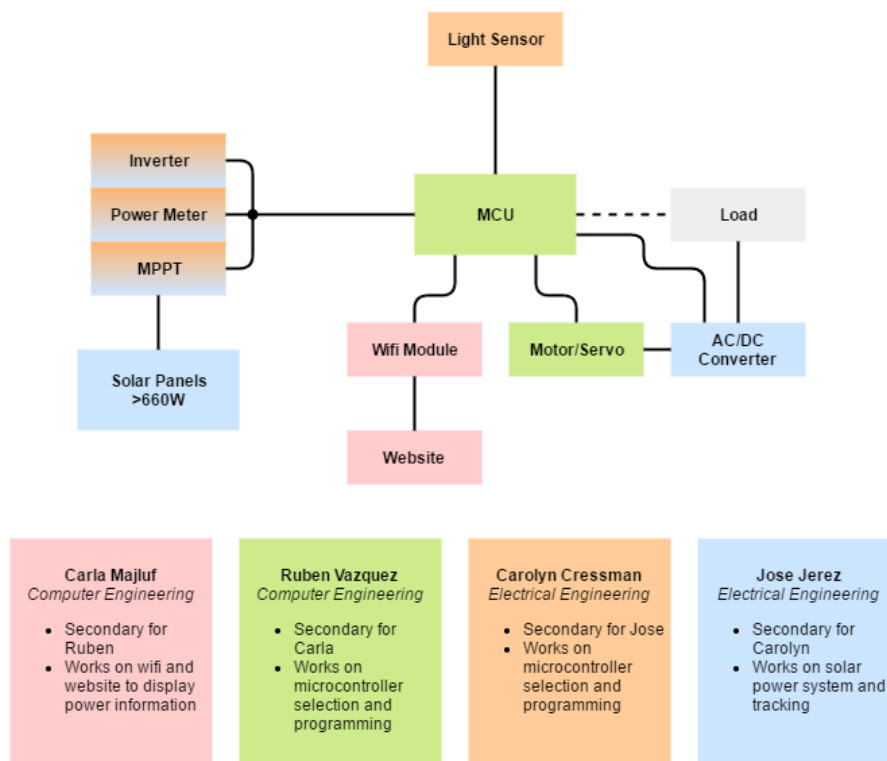

Figure 5.1.1 – Full-scale Diagram

The power subsystem will include the MPPT, the inverter, the solar panels, and the power meter. Most commercial inverters include both the power meter and the MPPT; so, we anticipate that we will not need to buy and connect each part. However, we will need to determine the cabling between the inverter, the solar panels, and the interconnection point provided by OUC.

The wireless subsystem will include the Wi-Fi module and the website. This subsystem will be responsible for receiving and sending the power generation information for the user to view and the platform for the information will be a website. This subsystem will connect with the MCU and the power meter to complete its task.

The load subsystem will include any additions the artists decide on, including lights, sound, etc. and the AC/DC converter. Including the inverter will prevent the need for a battery to utilize the collect solar power, which eliminate the need for maintenance.

Finally, the motion subsystem will include motors and the light sensors. This system will be responsible for tracking the sun and moving the solar panel towards the direct sunlight. This system will connect to the MCU and the solar panels.

5.1.2 Initial Design for Full-Scale Sculpture

After some research our team and the mechanical engineering team began to develop some initial ideas. We each created about 5 design, resulting in a total of 45 designs. Since the aesthetics are the most important trait to the clients, we want something that blended with the style of the surrounding neighborhood. Pictured in Figure 5.1.2 are some initial designs created by our teams.

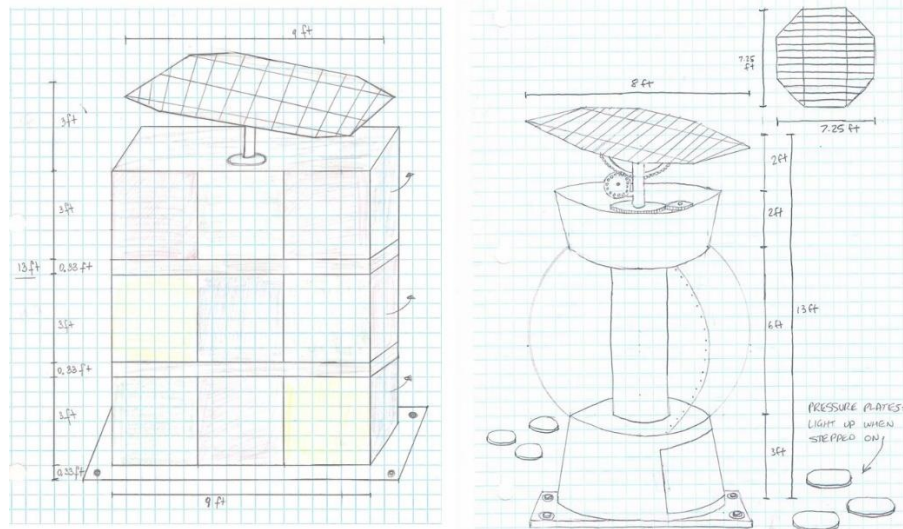

Figure 5.1.2 – Initial Project Designs

5.1.3 Current Design for Full-Scale Sculpture

After considering the mechanical team’s analysis and our own research we decided on a design to move forward with for now. Our teams are aware that the art teams influence on this project will most likely change the design significantly next term. The design we chose is shown below in Figure 5.1.3, it features a spherical shape for reasons discussed in the next section. This design would include either interactive lights in the sphere or rotation. The surrounding concrete at the base of the sculpture would have interactive lights. The spherical shape and angled base would make the sculpture difficult to climb. The sphere and interior column could be changed based on the artists desired look.



Figure 5.1.3 – Current Full-Scale Design

5.1.4 Structure for the Full-Scale Sculpture

The mechanical engineering team completed an analysis of different shapes and materials for the structure; in this section, we will quickly summarize their findings. In order for the structure to be able to handle strong winds sometimes found in our state, the mechanical engineers suggest a round of spherical structure, since they behave better than other shapes in these conditions. The standard in their industry is ability to withstand 120 mph winds. For the materials, the mechanical team found the best materials for low maintenance, good weather resistance, and low cost were those materials shown in Table 5.1.1 below.

<i>Type of Material</i>	<i>Material</i>	<i>Properties</i>
Metals	Aluminum Alloys & SS	<ul style="list-style-type: none"> • More dense • Relatively strong
Composites	CFRP & GFRP	<ul style="list-style-type: none"> • Less dense than metal • Higher strength-to-density than metal (CFRP) • Much more expensive
Polymers	PMMA (Acrylic) & Polycarbonate	<ul style="list-style-type: none"> • Less dense than composites • Similar strength-to-density as low grade Al alloy
Non-Technical Ceramics	Concrete	<ul style="list-style-type: none"> • Weather resistance • Very durable • Unmatched low cost • Easy to mold

Table 5.1.1 – Material Comparison

The solar panel mounted on top of the structure will be a custom shape made by a manufacturer. The mount used for the panel will have mechanical components to make the dual axis tracking capable. This structure is pictured below in Figure 5.1.4, it contains a couple gears which allow for the tilting motion and the rotation.

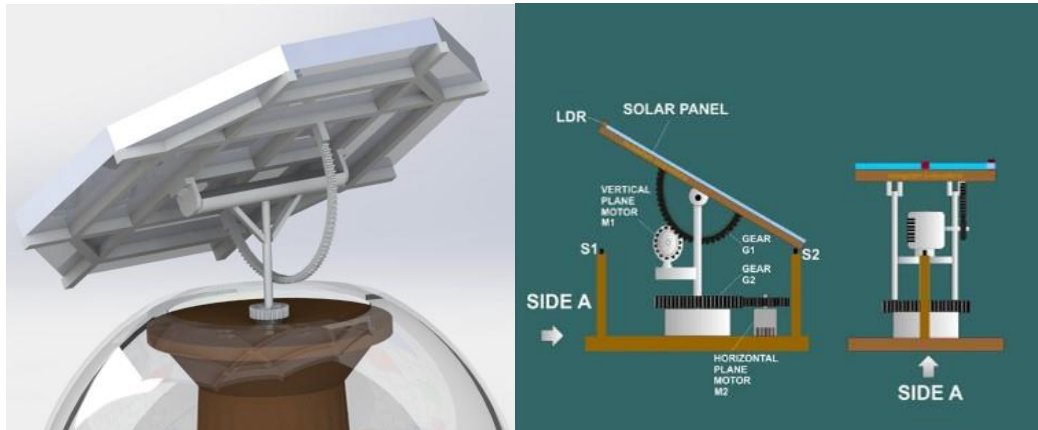

Figure 5.1.4 – Custom Solar Panel Mount Design

5.1.5 Wiring for the Full-Scale Sculpture

For the full-scale design, we will have three panels and a commercial inverter. The solar panels are connected using 10 AWG wire with H4 connectors. For grounding, we will run a continuous 8 AWG copper wire through the entire system. The NEC requires at least 14 AWG copper wire for grounding and with the 8 AWG we will meet that standard. Also, our grounding wire will be 2 sizes above the connectors and will be able to carry 1.6 times the current the connectors can. Table 5.1.2 shown below, is an abbreviated table of wire gauges and their characteristics.

AWG Gauge	Conductor Diameter	$\Omega / 1000'$	Max. Current for Power Transmission
00	0.3648"	0.0779	190A
4	0.2043"	0.2485	60A
8	0.1285"	0.6282	24A
10	0.1019"	0.9989	15A
14	0.0641"	2.525	5.9A

Table 5.1.2 – Abbreviated American Wire Gauge Table

5.1.6 Prototype System Structure

The prototype system structure is shown in Figure 5.1.2 below. Some of the main differences here is the inverter and is excluded from the prototype and a battery is included in the design to store the power generated from the solar panel. Also, the AC/DC converter is excluded because the charge stored will be DC power and utilized by the other components and this simplifies the circuitry.

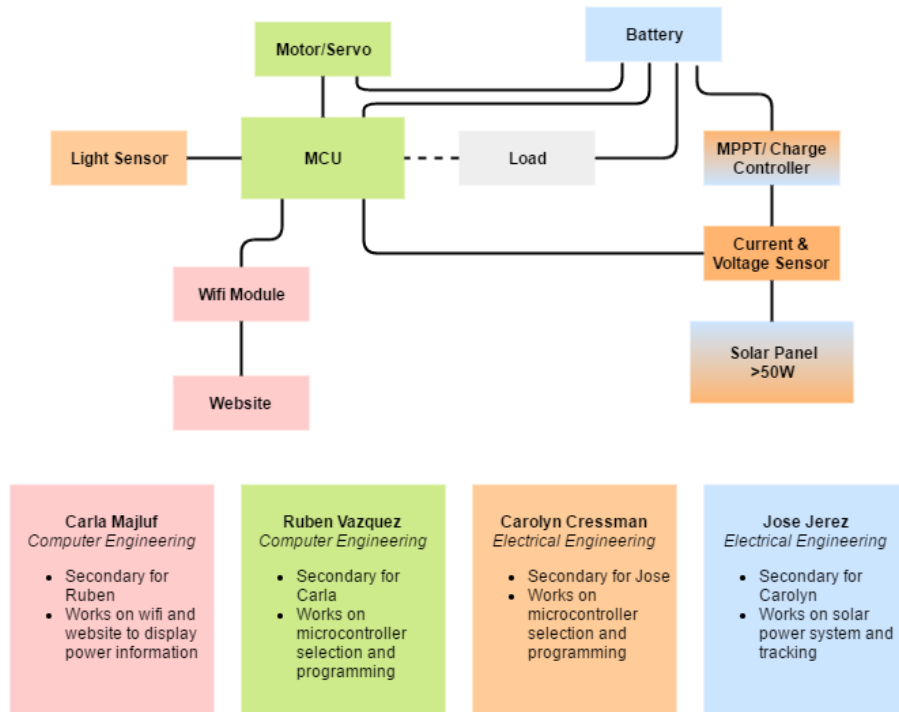

Figure 5.1.5 – Prototype Diagram

For the prototype, we will have three subsystems; these subsystems are power, motion, and wireless. These are very similar to the full-scale subsystem structures and will be discussed in detail in the next sections.

5.2 Power Subsystem

5.2.1 MPPT/Charge Controller

The BQ24650 IC is a high efficiency switched-mode battery charge controller that provides input voltage regulation and reduces charge current when input voltage falls below a programmed level. It features a wide input voltage capability, a 600kHz synchronous buck controller with current and voltage regulation, charge preconditioning, charge termination, and charge status monitoring. It accommodates Li-Ion battery chemistries and supports battery voltages from 2.1 V to 26 V.

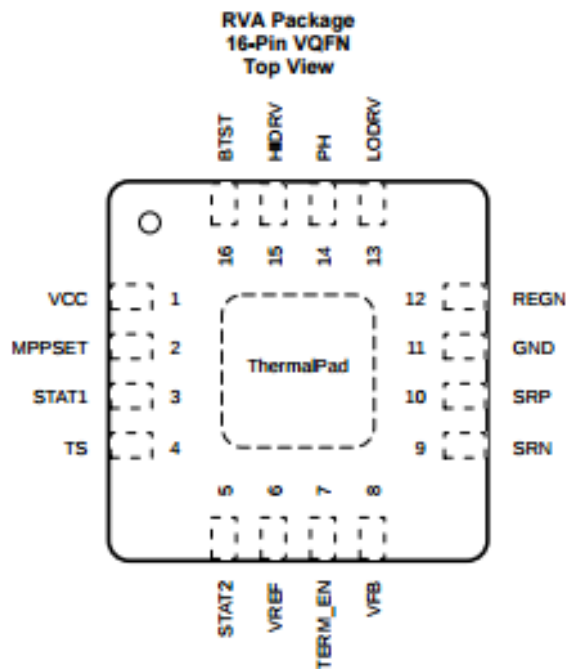

Figure 5.2.1 - BQ24650 Pinout Diagram

VCC is the power positive supply to the IC. It requires a 1 uF capacitor to GND and a 10 Ω resistor to filter out noise. MPPSET is the input voltage set point and is set by external resistors from input source to GND. The SAT1 pin is the open-drain charge status output to indicate charger operation. It is connected to the cathode of the LED with a 10 k Ω resistor going to the pull-up rail and the LED lights to indicate a charge in progress. TS is another input pin and it is the temperature qualification voltage input. STAT2 is another open-drain charge status output pin that is connected to the pull-up rail in the same way as STAT1. It lights up (goes LOW) to indicate when a charge is complete. When a fault occurs, both STAT1 and STAT2 go HI, and the LEDs turn off. VREF is a 3.3 V reference voltage output and requires a 1 uF capacitor. The TERM_EN pin is the charge termination enable. This pin can be pulled to GND to disable or tie to VREF to allow for charge termination; it cannot be left floating though. VFB is the charge voltage feedback adjustment. A resistor divider circuit coming from the battery terminals should tie to this node to adjust the output battery voltage regulation.

Pin 9 (SRN) is the charge current sense resistor negative input and pin 10 (SRP) is the charge current sense resistor positive input. A 0.1 uF should be placed from SRN to SRP to provide differential-mode filtering. Pin 11 is GND although it is also supposed to connect through the thermal pad underneath the IC. REGN is the PWM low-side driver positive 6 V supply output and it should have a 1 uF capacitor connecting it to GND. LODRV is the PWM low-side driver output and should be connected to the gate of the low side N-channel power MOSFET with a short trace. Pin 14 (PH) is the switching mode charge current output inductor connection. It should have a 0.1 uF bootstrap capacitor going from it to pin 16. HIDRV is the high-side driver output and it should connect to the gate of the high-side

N-channel power MOSFET. Pin 16 (BTST) is the PWM high-side positive supply. The Texas Instruments datasheet provides a reference design for this IC's typical application, this design has been used to develop our own; it is shown below in Figure 5.2.2.

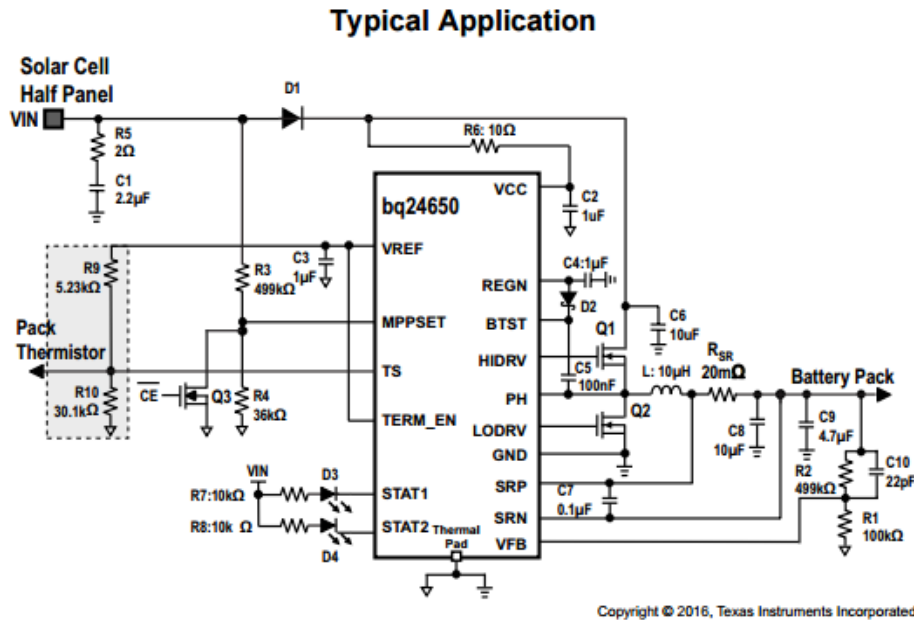

Figure 5.2.2 - BQ24650 Reference Design

However, this design does not have the same requirements that our project has so we must determine the values of the external components. First, the battery voltage must be set using the ratio between R1 and R2 in the equation:

$$V_{BAT} = 2.1V * (1 + R2/R1)$$

Since the maximum voltage of the battery when it is fully charged is 8.4 V, we must design for this value. By letting R1 = 100 KΩ, we find R2 to be 300 KΩ.

The maximum power point tracking input voltage regulation of the solar panel is set by the resistors R3 and R4. This number comes from the solar panel characteristics and equals 17.8 V for our panel. Using the given equation:

$$V_{MPPSET} = 1.2V * (1 + R3/R4)$$

We let R4 = 35 KΩ and find R3 to be 470 KΩ.

Next, we must set the battery current regulation. This is set by the R_{SR} resistor connected from SRP to SRN. The value is found according to the following equation:

$$I_{CHARGE} = 40mV / R_{SR}$$

Our battery has a standard charge current of 1.04A and a rapid charge current of 5.2 A. Using 20 mΩ sense resistor will make the charging current 2 A.

On power-up, if the battery has been discharged below the V_{LOW} threshold, the BQ24650 applies the pre-charge current. If the V_{LOW} threshold is not reached within 30 minutes of initiating pre-charge, the charger turns off and a fault status is indicated on the status pins. This pre-charge current is 10% of the fast charge current according to the following equation:

$$I_{CHARGE} = 4mV / R_{SR}$$

Similarly, the BQ24650 monitors the charging current and detects termination while the voltage on the VFB pin is higher than the VRECH threshold and the charge current is less than the I_{TERM} threshold set by the following equation:

$$I_{TERM} = 4mV / R_{SR}$$

Also, whenever the VCC pin voltage is less than the SRN pin voltage, the device enters a SLEEP mode to minimize current drain from the battery.

The datasheet recommends a 10 uH output inductor and 15 uF output capacitor for a 2 A charge current and gives the status of the state pins as shown below in Table 5.2.1.

Table 2. STAT Pin Definition for bq24650

CHARGE STATE	STAT1	STAT2
Charge in progress	ON	OFF
Charge complete	OFF	ON
Charge suspend, overvoltage, sleep mode, battery absent	OFF	OFF

Table 5.2.1 - STAT1 & STAT2 states

The BQ24650 also has temperature sensing capabilities when connected to a battery pack's thermistor. The battery has a recommended operating temperature of -20 ° to 60 ° C and the controller continuously monitors this by measuring the voltage between the TS pin and GND. If it measures a temperature outside of the V_{LTF} and V_{HTF} thresholds the controller suspends charge and waits until the battery temperature is within the range.

5.2.2 Battery

The battery that we will use in our prototype will be the Tenergy 7.4 V 5200 mAh Li-Ion battery pack. It has a nominal voltage of 7.4 V and a fully charged voltage of 8.4 V. It also has a standard charge current of 1.04 A and a maximum discharge current of 5.2 A. In order to figure out whether one battery will meet the power requirements of our components we listed out an approximation of the power requirements of each one, shown in Table 5.2.2 below. Based on these approximations, one battery should be sufficient to power our prototype for at least 10 minutes.

Component	Voltage Required	Current Required
MCU	3.3 V	600 mA
Motor drivers	3.3 V	700 mA
Phototransistors	--	5 mA
Wi-Fi Breakout Board	5.0 V	300 mA

Table 5.2.2 - Power Requirement Approximations

Figure 5.2.3 shown below shows how every component is supplied power. The solar panel power will go to the maximum power point tracker which will in turn charge the battery. The 7.4 V battery will connect and give power to the motor

controllers and 3.3 V voltage regulator. The regulator will feed the microcontroller, phototransistors, and Wi-Fi module from there.

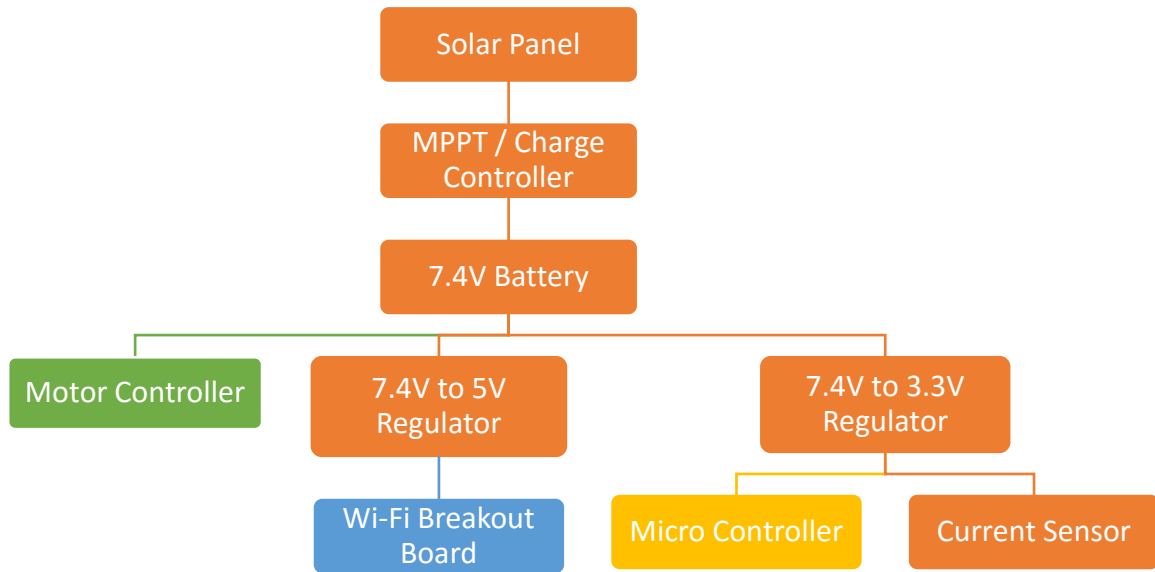

Figure 5.2.3 – Power Subsystem Diagram

5.2.3 Voltage Regulators

For our project we need two separate voltage regulators in order to utilize the Wi-Fi breakout board, the microcontroller, and current sensor. The Wi-Fi module requires a supply voltage of 5.0V and contains a 5V to 3.3V regulator; while the microcontroller and current sensor need a supply voltage of 3.3V. We utilized TI Webench to build both regulators; the 7.4V to 5.0V regulator Webench results are pictured below in Figure 5.2.4 and the 7.4V to 3.3V regulator Webench results are pictured below in Figure 5.2.5. The results show a diagram in the far left that compare footprint to efficiency. Our chosen design has a small footprint and a high efficiency. For the small footprint and high efficiency, this design has a low bill of material cost.

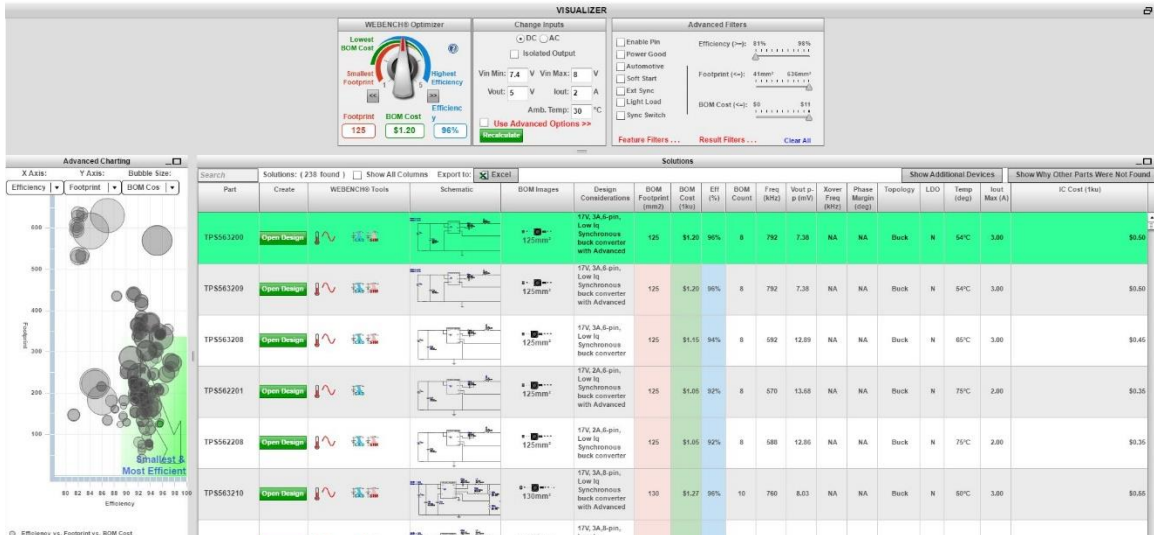

Figure 5.2.4 – Webench Results for 7.4V to 5.0V Regulator



Figure 5.2.6 – Webench Results for 7.4V to 3.3V Regulators

The design we chose for each regulator uses the same part, TPS563200DDC. The value of R_{fbb} and the capacitors used to filter the input and output have the same values for both designs. While the value of R_{fbt} and the inductor differ in each design. The circuits are displayed below in Figure 5.2.7 and Figure 5.2.8 for the 7.4V to 5.0V and the 7.4V to the 3.3V regulators, respectively.

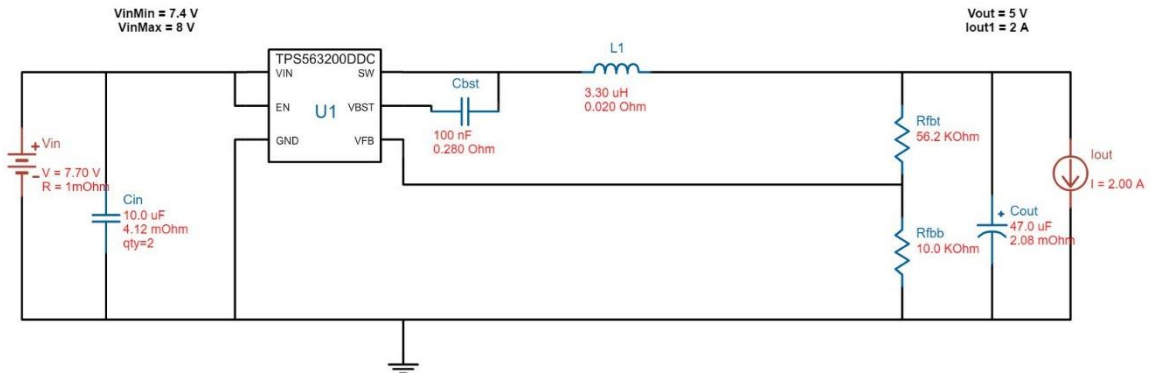

Figure 5.2.7 – Circuit for 7.4V to 5.0V Regulator

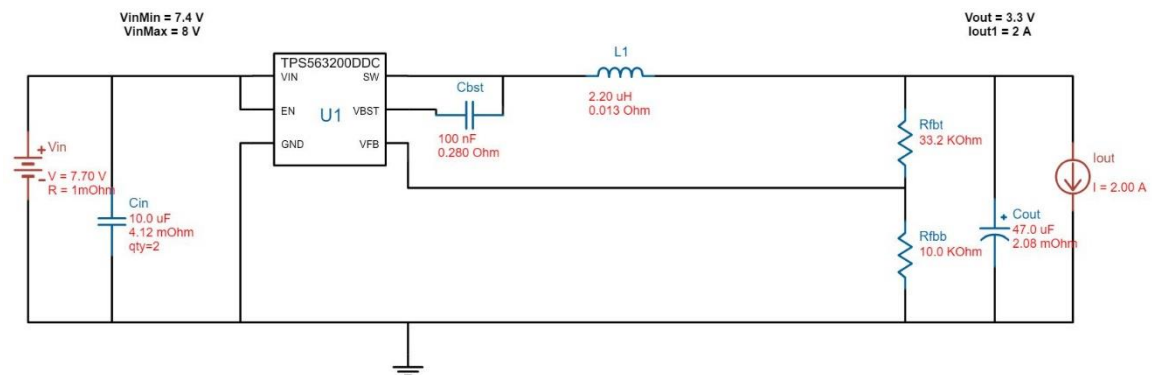

Figure 5.2.8 – Circuit for 7.4V to 3.3V Regulators

Taking these designs into account, we chose to verify the designs using information from the TPS563200DDC datasheet. First we verify the circuit connections using the typical application diagram which uses a 4.5V – 17V input to create a 1.05V output, it is shown below in Figure 5.2.9. Comparing Figure 5.2.9 and the designs from TI Webench the connections are correct. Although, there is a missing 10kΩ resistor missing between the EN pin and Vin.

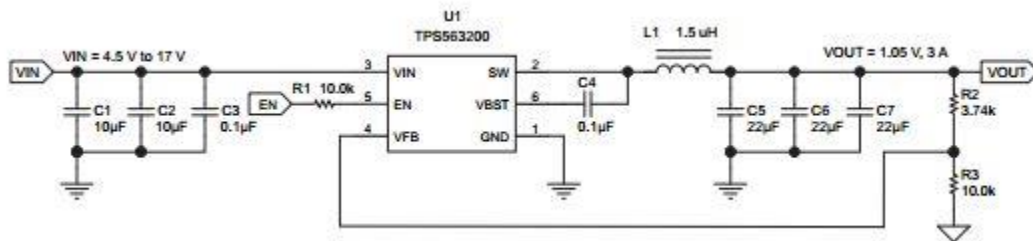

Figure 5.2.9 – Reference Design for TPS5632200DDC

Knowing the connections are correct, we want to verify the component values. Using Table 5.2.3 from the datasheet, we compare the component values in the TI Webench designs and the table component values. Table 5.2.3 references C8 and C9 which are not in the reference design or anywhere else in the datasheet but the equations above the table in the datasheet reference C_{out} , therefore the value in the Webench designs of $47\mu\text{F}$, which is between the recommended values, are acceptable. The values for the R3 and L1 in the Webench design are the correct values. The value for R2 in the 7.4V to 3.3V regulator is correct, but the R2 value in the 7.4V to 5V regulator design is different than the value in Table 5.2.3.

Output Voltage (V)	R2 (k Ω)	R3 (k Ω)	L1 (μH) TPS563200			C8 + C9 (μF)
			MIN	TYP	MAX	
1	3.09	10.0	1.0	1.5	4.7	20 - 68
1.05	3.74	10.0	1.0	1.5	4.7	20 - 68
1.2	5.76	10.0	1.0	1.5	4.7	20 - 68
1.5	9.53	10.0	1.0	1.5	4.7	20 - 68
1.8	13.7	10.0	1.5	2.2	4.7	20 - 68
2.5	22.6	10.0	1.5	2.2	4.7	20 - 68
3.3	33.2	10.0	1.5	2.2	4.7	20 - 68
5	54.9	10.0	2.2	3.3	4.7	20 - 68
6.5	75	10.0	2.2	3.3	4.7	20 - 68

Table 5.2.3 – Recommended Component Values

In order to determine which value to use, we will use the following equation found in the datasheet for V_{out} .

$$V_{OUT} = 0.765 \times \left(1 + \frac{R2}{R3}\right)$$

Using this equation, the values in the Webench design for the 7.4V to 5V regulator gives us the following value.

$$V_{OUT} = 0.765 \times \left(1 + \frac{56.2\text{k}\Omega}{10\text{k}\Omega}\right) = 5.0643 \text{ V}$$

Using the values in Table 5.2.3 for R2 and R3 for an output voltage of 5V, we get the following value.

$$V_{OUT} = 0.765 \times \left(1 + \frac{54.9\text{k}\Omega}{10\text{k}\Omega}\right) = 4.9649 \text{ V}$$

The output voltage value given the values for R2 and R3 in the Webench design is closer to 5V than the values in the datasheet; therefore, we will use the values in the Webench design.

For the prototype PCB we will need to reference the pin/out diagram from the data sheet shown below in Figure 5.2.10. The above circuits for the regulators are not

shown with the pins in the correct order; therefore, we will need to pay close attention when designing the PCB layout.

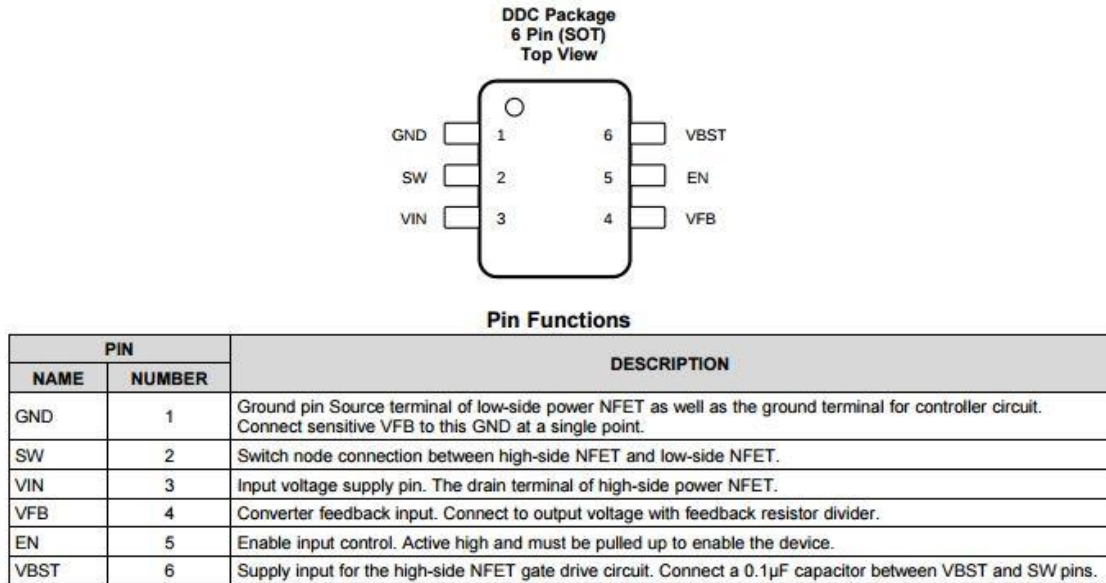

Figure 5.2.10 – Pin/Out Diagram from Datasheet

5.2.4 Current Sensor

The current sensor we chose to use is the Allegro ACS711KLCTR-12AB-T. Figure 5.2.11 shown below is a pin out diagram for the current sensor. The figure shows the connections of the pins inside of the chip, the pins, and their labels for each package type. We are Using the LC package because the part is a surface mount device which makes soldering the part to the PCB board easier than the EX package which is a QFN device.

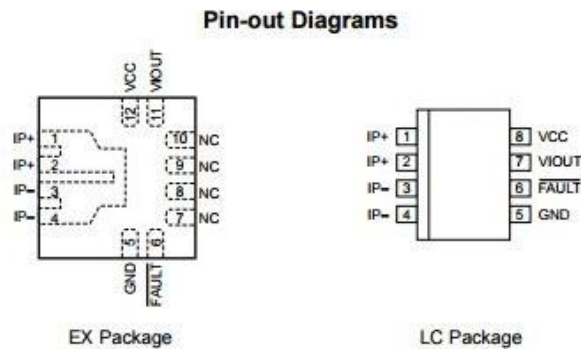

Figure 5.2.11 – Pin Out Diagram for Current Sensor

Below in Figure 5.2.12, is a typical application of the current sensor. The V_{CC} pin is connected to the V_{out} pin of the 7.4V to 3.3V regulator and a $0.1\mu\text{F}$ capacitor to filter the input. The $IP+$ pins are tied to the output of the solar panel and the $IP-$ pins are tied to the input of the MPPT. V_{IOUT} is tied to an input pin on the microcontroller.

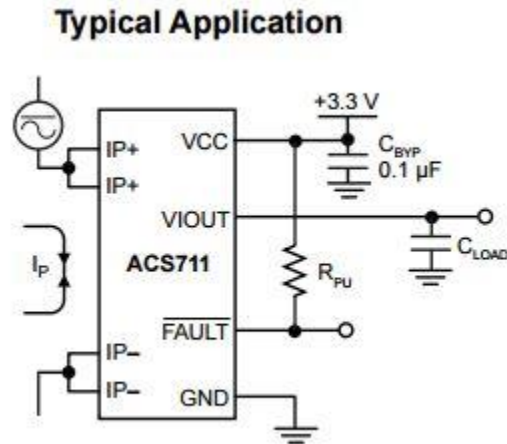

Figure 5.2.12 – Typical Application of Current Sensor

5.2.5 Solar Panel

The solar panel will produce the energy required to recharge the battery. It will connect to the maximum power point tracker through the terminal on the V_{CC} pin. The maximum power point tracker will keep the solar panel working at its optimum power and will ensure that the battery is appropriately and safely charged.

Before solar panel connection goes to the maximum power point tracker, we must first measure the amount of current going through it, so we will connect it first to our current sensor so that information can then be passed along to our microcontroller. From there, the data can be sent out through the Wi-Fi module.

5.2.6 MPPT System Design and Operation

Texas Instruments does not offer a PSCICE model of the BQ24650 integrated circuit so we could not simulate a design but they do offer an evaluation module that comes with all the necessary external components placed on a printed circuit board. Therefore, in order to design a schematic for our charge controller we referenced both the BQ24650 datasheet and the evaluation module. Most of the external components used were the ones recommended on the datasheet of the

IC or the evaluation module. Each of the components should satisfy certain requirements as outlined in below:

Inductor – The 600 kHz switching frequency allows for the use of small inductor values. The inductor saturation current must be higher than the charging current plus half the ripple current, else it will not operate in continuous conduction mode.

Input capacitor – This capacitor should have enough ripple current rating to absorb input switching ripple current. The maximum current ripple occurs when the duty cycle is 0.5 or when closest to that. This capacitor should have a low equivalent series resistance and must be placed as close as possible to the drain of the high side MOSFET and source of the low side MOSFET. The voltage rating must be higher than the normal input voltage level.

Output Capacitor – This capacitor should have enough ripple current rating to absorb output switching ripple current. The preferred ceramic capacitor has a 35 V or higher rating.

Power MOSFETs – Two N-channel MOSFETs are used for the charge controller. The gate drivers are internally integrated into the IC with 6 V of gate drive voltage. 30 V or higher rating on the MOSFETs is recommended for a 20 V input.

Below is a Table 5.2.4 of the components selected to be used:

Part Designator	Qty	Description
Q1, Q2	2	N-channel MOSFET, 40-V, 10-A, PowerPAK SO-8, Vishay-Siliconix, Si7288
D2	1	Diode, Dual Schottky, 30-V, 200-mA, SOT-23, Fairchild, BAT54C
D3, D4	2	LED Diode, Green, 2.1-V, 20-mA, LTST-C190GKT
RSR	1	Sense Resistor, 20-m Ω , Vishay-Dale, WSL1206R0200DEA
L1	1	Inductor, 10- μ H, 7-A, Vishay-Dale IHLP-2525CZ
C6, C8	2	Capacitor, Ceramic, 10- μ F, 35-V, 20%, X7R, 1210, Panasonic
C9	1	Capacitor, Ceramic, 4.7- μ F, 35-V, 20%, X7R, 1210, Panasonic
C2, C3, C4	3	Capacitor, Ceramic, 1- μ F, 35-V, 10%, X7R, 0805, Kemet
C5, C7	2	Capacitor, Ceramic, 0.1- μ F, 35-V, 10%, X7R, 0805, Kemet
C1	1	Capacitor, Ceramic, 2.2- μ F, 35-V, 10%, X7R, 1210, Kemet
C10	1	Capacitor, Ceramic, 22-pF, 35-V, 10%, X7R, 0603 Kemet
R1	1	Resistor, Chip, 100-k Ω , 1/16-W, 0.5%, 0402
R2, R3	2	Resistor, Chip, 499-k Ω , 1/16-W, 0.5%, 0402
R4	1	Resistor, Chip, 36-k Ω , 1/16-W, 0.5%, 0402
R9	1	Resistor, Chip, 5.23-k Ω , 1/16-W, 1%, 0402

R10	1	Resistor, Chip, 30.1-k Ω , 1/16-W, 1%, 0402
R7, R8	2	Resistor, Chip, 10-k Ω , 1/16-W, 5%, 0402
R6	1	Resistor, Chip, 10- Ω , 1/4-W, 5%, 1206
R5	1	Resistor, Chip, 2- Ω , 1-W, 5%, 2012
D1	1	Diode, Schottky Rectifier, 40-V, 10-A, PDS1040
Q3	1	N-Channel MOSFET, 60-V, 115-mA, SOT-23, 2N7002DICT

Table 5.2.4 - External Components Used in Charge Controller Circuit

The BQ24650 uses a synchronous buck PWM converter to regulate the output voltage. It uses a feedback output (FBO), error amplifier input (EAI), and error amplifier output (EAO) to tweak its output. It does this by comparing an internal sawtooth ramp to the internal EAO signal to vary the duty cycle of the converter. The charger operates in continuous-conduction mode when the SRP-SRN voltage is above 5 mV and discontinuous conduction mode when that voltage is below 1.25 mV. Shown below in Figure 5.2.13 is the operational flowchart for the BQ24650 IC.

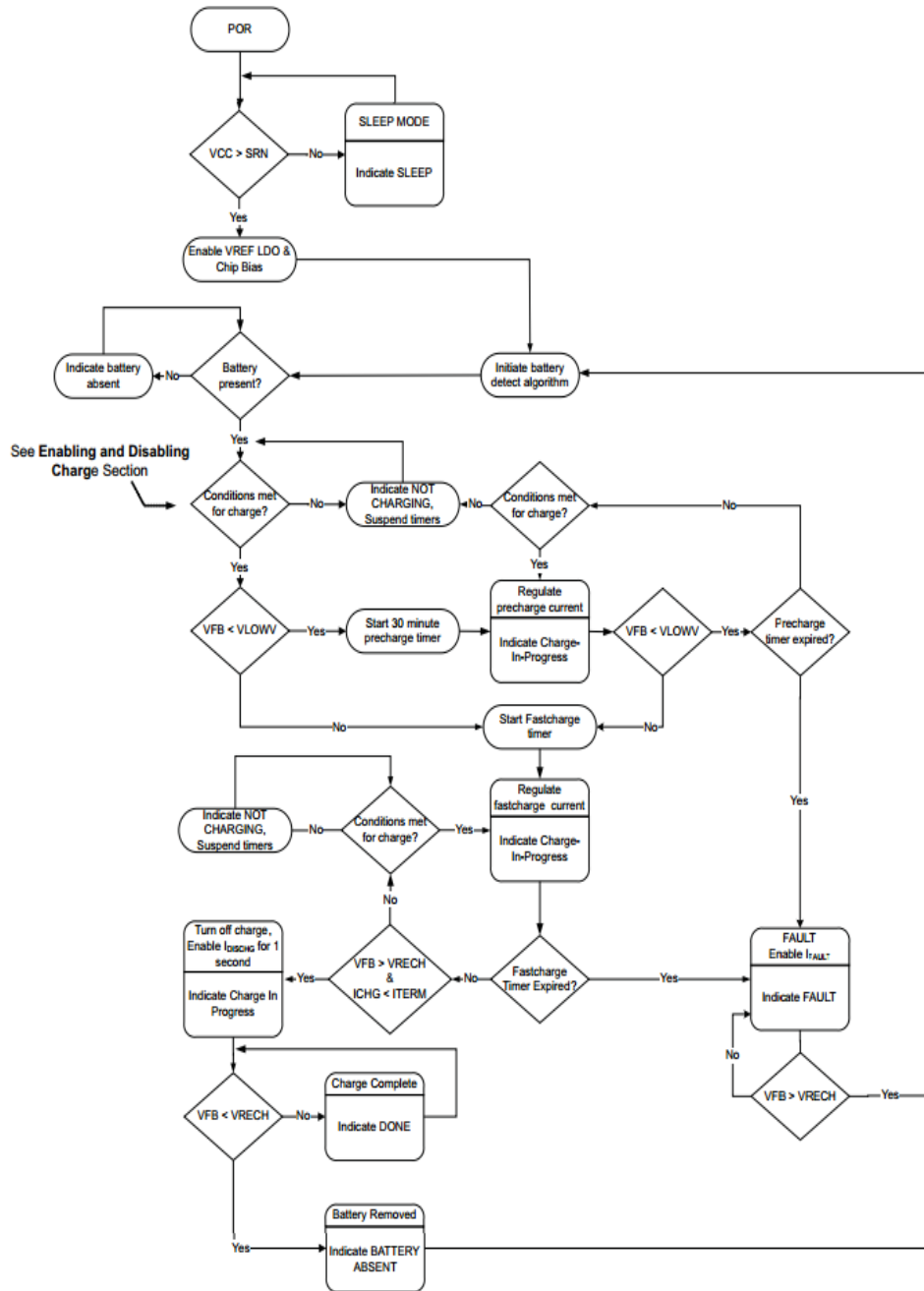

Figure 5.2.13 - Operational Flowchart for the BQ24650 IC

In creating our PCB, we were also required to reference the datasheet again because it lays out certain guidelines we must follow to minimize switching node rise and fall times. The following PCB layout priority list was followed in designing our layout.

- Place input capacitor as close as possible to the switching MOSFET supply and ground connections and place both parts on the same layer of the PCB
- The charge controller should be placed close to the switching MOSFET gate terminals and gate drive signal traces should be kept short for a clean MOSFET drive
- Place inductor input terminal as close as possible to the switching MOSFET output terminal to minimize electrical and magnetic field radiation.
- The charging current sensing resistor must be placed right next to the inductor output. Route the sense leads across R_s back to the IC in the same layer, close to each other, as shown in Figure 5.2.14. Do not route through a high current path. Place decoupling capacitor on these traces next to the IC.

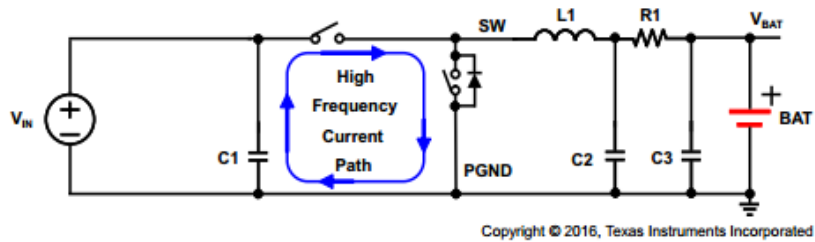

Figure 5.2.14 - High Frequency Current Path

- Place output capacitor next to the sensing resistor output and ground.
- Output capacitor ground connections need to be tied to the same copper that connects to the input capacitor ground before connecting to system ground.
- Ensure that the exposed thermal pad on the backside of the IC package is soldered to the PCB ground. Ensure that there are sufficient thermal vias directly under the IC connecting to the ground plane.
- Decoupling capacitors must be placed next to the IC pins and make trace connection as short as possible.

One recommendation made on the datasheet that we could not follow was to make two separate analog and power grounds. The reason for this recommendation is that digital signals tend to be noisy and analog signals are susceptible to that noise. The way to correct this is to separate the two layers

and connect them at one point as a star connection. The datasheet recommends this star connection to be at the thermal pad underneath the IC. However, because EAGLE limits the free version of its software to a two-layer board, adding a second ground plane was not feasible for us. Below in Figure 5.2.15 is the charge controller schematic and in Figure 5.2.16 is the charge controller board layout.

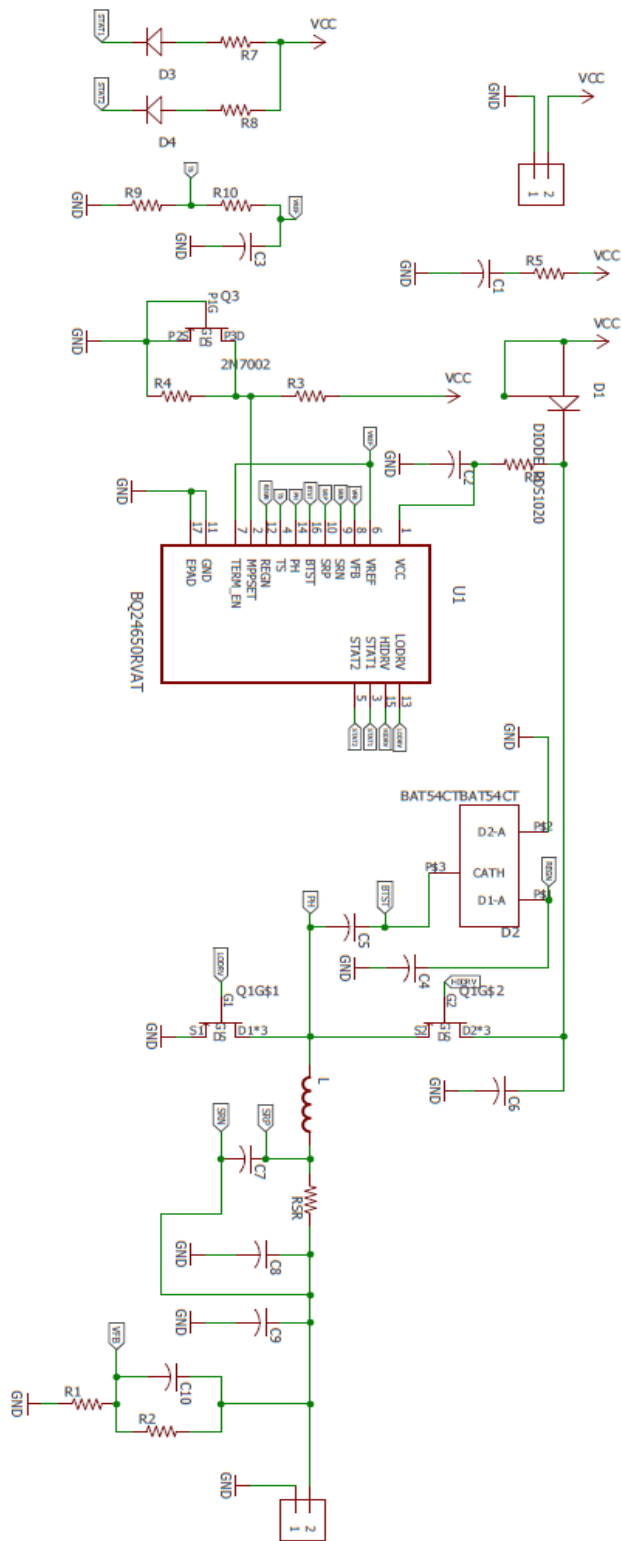

Figure 5.2.15 - Charge Controller Schematic

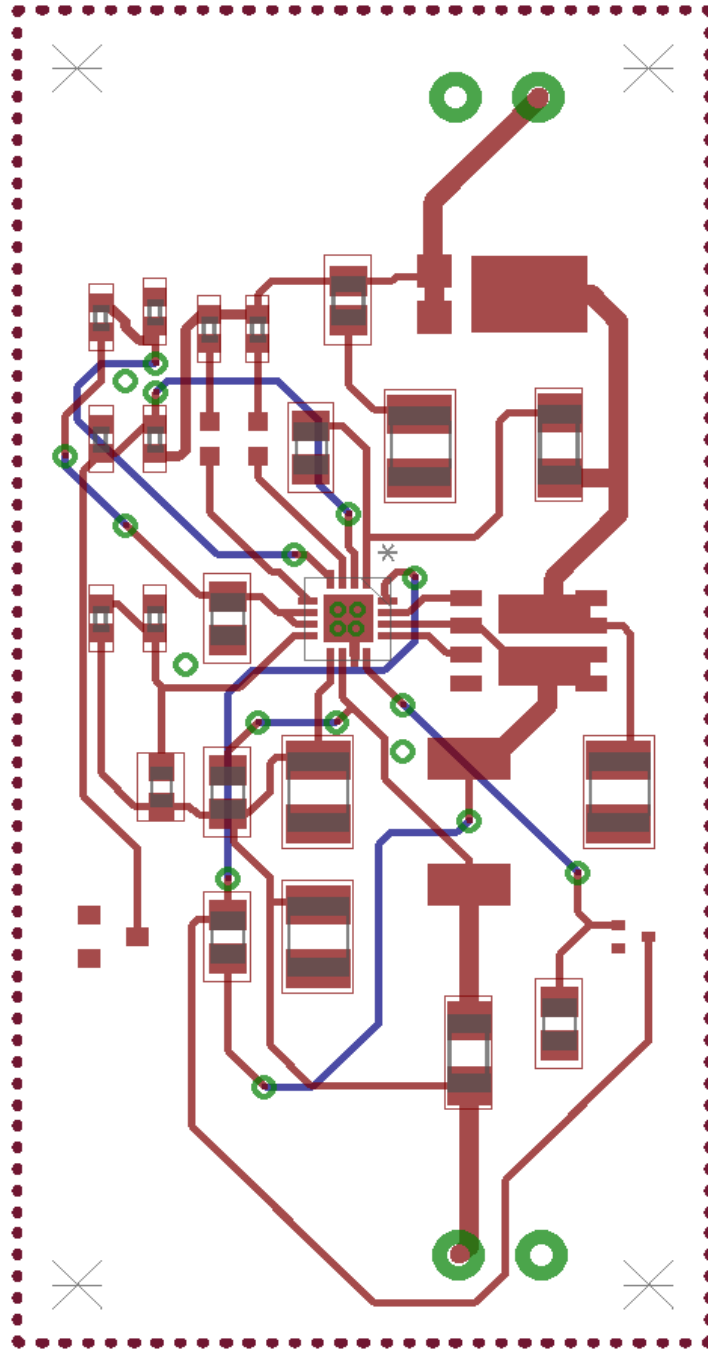

Figure 5.2.16 - Charge Controller Board Layout

5.3 Motion Subsystem

5.3.1 Motion Subsystem Overview

This subsystem focuses on providing control to the motors in order to move the solar panels to be facing the sun at all times. Figure 5.3.1 below shows the components and their relationships to each other within the subsystem.

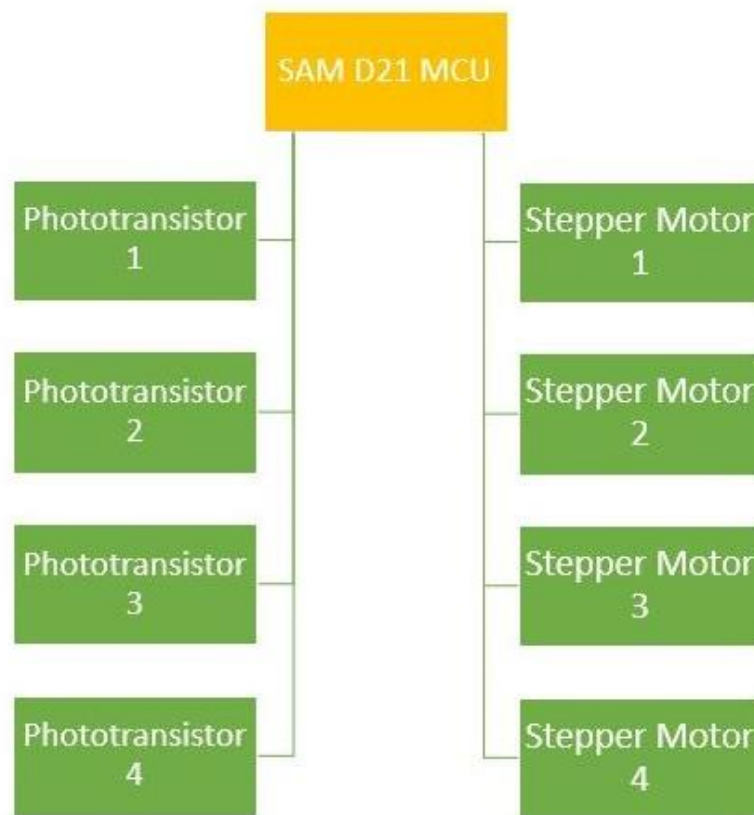

Figure 5.3.1 – Motion Subsystem Diagram

5.3.2 Microcontroller Design Layout

The MCU that we will use for the motion subsystem is the ATMEL SAM D21G18. This microcontroller features 256 kB of Flash memory, 32 kB of static RAM, 48 pins, and a maximum of 48 MHz operating frequency. Of the 48 pins contained on the SAM D21G MCU, 38 of them are general-purpose input and output pins, 10 of which are analog input channels. These analog inputs will be useful in reading data from the current and voltage sensors; however, for this subsystem, only the digital

pins will be considered. To further understand the architecture of the MCU, Figure 5.3.2 of the QFN48/TQFP48 layout of the MCU is shown below.

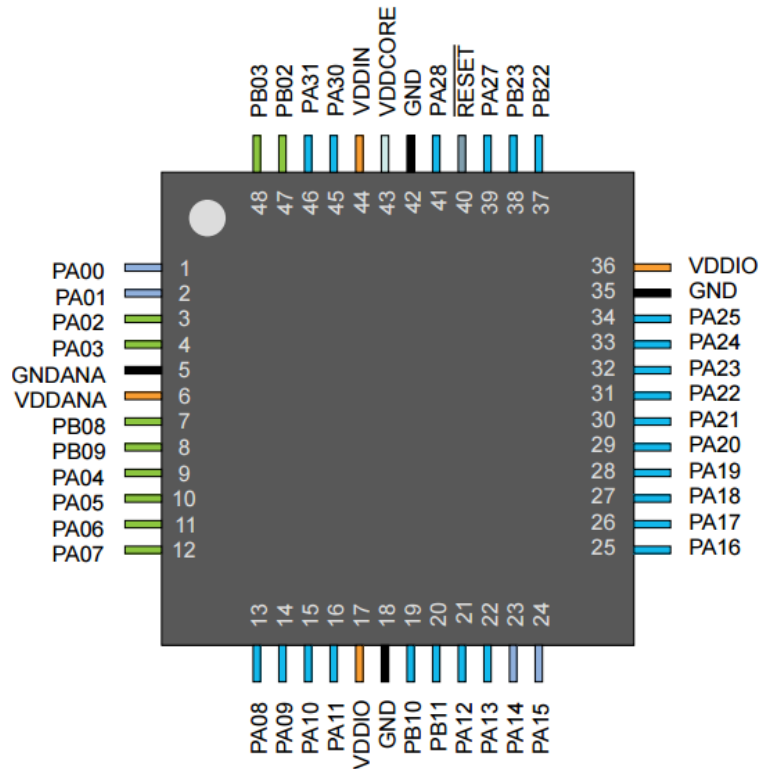

Figure 5.3.2 – QFN48/TQFP48 Layout of SAMD21 MCU

From the figure above, we can see that there are two ports: Port A and Port B. Each of these ports contain fully configurable pins that we can designate as either input or output depending on what we are trying to implement. These pins can be configured by setting up the Pin Configuration register on the MCU. This MCU has a naming convention that we can use to select the different pins on the chip. Table 5.3.1 below explains the naming convention used to access the pins.

Signal name	Type	Description
Pxy	Digital I/O	General-purpose I/O pin y in group x

Table 5.3.1 – Accessing the Different Pins on The SAMD21 MCU

From the above figure, x represents the port letter and y represents the pin number expressed as a two-digit number; so, for example, in order to access Pin 1 on Port A we would use PA01 to do this. Also, as mentioned before, we can set up the pins to act as either input or output pins. This involves setting up the bits of the

PINCFGy register in order to designate what pins are inputs and which pins are outputs. Like the naming convention for accessing the pins above, y represents the pin number expressed as a two-digit number. Table 5.3.2 below shows how to set up the pins in this manner.

DIR	INEN	PULLEN	OUT	Configuration
0	0	0	X	Reset or analog I/O: all digital disabled
0	0	1	0	Pull-down; input disabled
0	0	1	1	Pull-up; input disabled
0	1	0	X	Input
0	1	1	0	Input with pull-down
0	1	1	1	Input with pull-up
1	0	X	X	Output; input disabled
1	1	X	X	Output; input enabled

Table 5.3.2 – Pin Configuration Bit Table

Relating this material back to the motion subsystem, there will be four light sensors that will be connected to the MCU in order to receive data about where the most sunlight is located in the environment. All of the light sensors will require four analog pins to receive the data from the light sensors. How the light sensors will transmit this data and the design of the light sensors will be explained in the following sections. Next, using the data gathered from the light sensors, we will be adjusting the motors to orient the solar panels to produce the most power using the motor drivers connected to the MCU. The motor driver design and the design for each motor will also be discussed in the following sections.

5.3.3 Light Sensor Design

In order for the motors to receive the proper control signals to move the solar panel into a position where it is receiving the maximum amount of light, we will have to utilize light sensors in our design. In order to do this, the SAM D21 MCU will read the voltage from the light sensor systems to determine where the most light is hitting the solar panel; using this information, control signals will then be sent to the two motors to orient the solar panel appropriately. This process repeats to continue positioning the solar panel in order to receive the most amount of light. To continue, a discussion of how these light sensors operate and how to read the voltages from the light sensors will be necessary.

A light sensor is typically composed of a resistor and some type light-dependent circuit element. For our design, we have chosen to use the phototransistor since it

is ROHS compliant as opposed to the photoresistor. The circuit symbol and figure for an npn phototransistor is shown below in Figure 5.3.3.

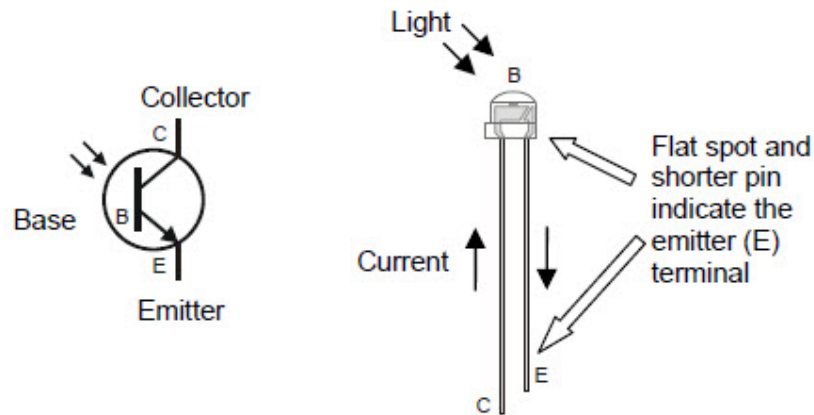

Figure 5.3.3 – Circuit Symbol and Figure of an NPN Phototransistor

The main difference between a npn transistor and npn phototransistor as can be seen below is the base terminal. For an npn transistor, the base terminal has its own pin and can be connected to some voltage source as opposed to the npn phototransistor, where there are only two pins; one for the collector and one for the emitter, where the base takes in light from the surrounding to allow current to pass through. We can then measure the collector current to determine how much light is present. One topic of interest worth mentioning when using light sensors is the idea of measuring light. In datasheets, the SI units of lux are used to describe the measure of intensity of light that strikes or passes through a surface. In the Table 5.3.3 below, values of lux for common lighting scenarios are highlighted.

Illuminance	Example
0.002 lux	Moonless clear night sky
0.2 lux	Design minimum for emergency lighting (AS2293).
0.27 - 1 lux	Full moon on a clear night
3.4 lux	Dark limit of civil twilight under a clear sky
50 lux	Family living room
80 lux	Hallway/toilet
100 lux	Very dark overcast day
300 - 500 lux	Sunrise or sunset on a clear day. Well-lit office area.
1,000 lux	Overcast day; typical TV studio lighting
10,000 - 25,000 lux	Full daylight (not direct sun)
32,000 - 130,000 lux	Direct sunlight

Table 5.3.3 – Common LUX Values

The main idea behind the phototransistor is that more current is allowed to flow from the collector terminal to the emitter terminal as the light that is hitting the base terminal of the phototransistor increases. As a result, if we connect a resistor in series with the phototransistor, we can measure the voltage at one of the terminals of the resistor to determine difference in lights between the light sensors; so, with this in mind, there are two circuit configurations that we can implement: the common emitter circuit and the common collector circuit, also known as the emitter follower circuit. Let us discuss the common emitter circuit first. Figure 5.3.4 shows the circuit diagram of the common emitter configuration for a light sensor is shown below.

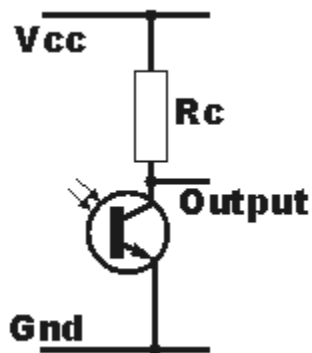

Figure 5.3.4 – A Common Emitter Configuration for a Light Sensor

With a common emitter configuration, the resistor is connected to V_{CC} and to the collector terminal of the phototransistor. Then, the emitter terminal of the phototransistor is connected to the common node, or ground. From here, the voltage at the collector terminal is then measured to determine how much light is hitting the phototransistor. So, when no light is hitting the phototransistor, no current flows to the ground and V_{CC} appears at the output. On the other end, when there is a high intensity of light, the current flows directly to ground and ground appears at the output. So with this configuration, we see opposite results: When there is no light, we see the full V_{CC} when we measure the voltage at the terminal of the collector. When there is light, the current flows to ground and the output reads 0 Volts or low. This configuration could be beneficial since less current would be flowing into the analog pin of the controller when there is light present thus possibly reducing the heat of the system while withstanding the atmospheric temperature. The next configuration that we are going to look at is the common collector circuit, also known as the emitter follower circuit. Below is Figure 5.3.5 that shows the circuit diagram of the emitter follower configuration for a light sensor.

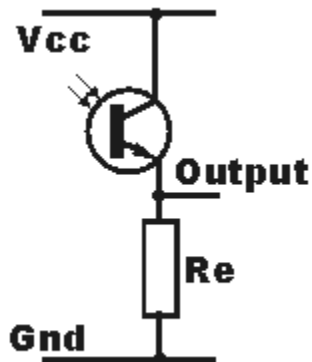

Figure 5.3.5 – A Common Collector Configuration for a Light Sensor

With the emitter follower configuration, V_{cc} is connected to the terminal of the collector, the terminal of the emitter is connected to the terminal of the resistor, and the other terminal of the resistor is connected to the common node, or ground. We then measure the voltage of the emitter terminal. With this configuration, when there is no light present, current does not flow through the resistor. According to Ohm's law, when no current flows through the resistor, the voltage across the resistor will be 0 Volts and thus that will be the voltage measured at the output. When there is light present, current will start to flow through the resistor, thus producing a voltage across the resistor, which will be read at the output. In summary, when there is light present, a positive voltage reading will be measured from the output terminal; when there is no light present, zero voltage will be measured from the output terminal. Making a comparison between the two configurations, the emitter follower seems easier to understand from an empirical perspective; however, with the common emitter configuration we may be able to reduce the heat of the system at a given instance, which is crucial since the solar tracker will be located outside and will be subject to high temperature conditions. Also, reducing the heat of the system will result in a lower chance of maintenance and a longer life of the entire system, which is a crucial part of our requirements specifications. Having discussed the design of the light sensor, we can now move forward with a discussion of the motor system, consisting of the drivers and the motors themselves.

5.3.4 Motor Driver Design Layout

The next part of our motion subsystem is the motor driver. The data collected from the light sensors will allow the control unit to send signals to the motors to drive them in the right direction. In order to prevent damage to the motors and to create an easy interface with the motors, we will be using motor drivers. The motor driver that we are using for the solar tracker is the ROB-12779 EasyDriver Stepper Motor Driver. Figure 5.3.6 below shows a front view layout of the top of the board.

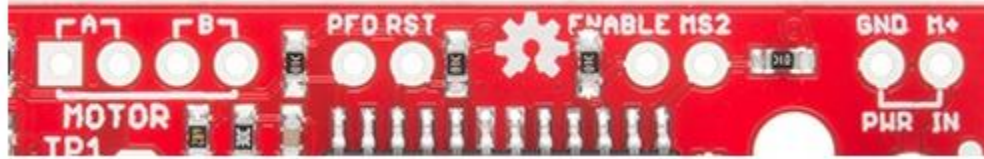

Figure 5.3.6 – Front View of the Top Portion of the EasyDriver

The EasyDriver comes with several pins broken out that serve different purposes. Going from left to right, the two pairs of pins with A and B will be connected to the four leads of the motor. These pins will power the coils in the proper sequence to drive the motor. The PFD pin controls the output current decay mode and is controlled by connecting a certain range of voltages. A voltage greater than $0.6 V_{cc}$ sets the decay mode to slow, less than $0.21 V_{cc}$ set the decay mode to fast, and any voltage between the two aforementioned voltages sets the decay mode to mixed. RST causes all STEP and FET functionality to cease when set to low logic. ENABLE will cease all FET functionality when set to high logic. MS2 is a logic input that is used to set the stepping resolution of the motor. GND represents ground and M+ represents the power supply voltage, which can range anywhere from 6 to 30 Volts. Figure 5.3.7 below shows a front view layout of the bottom of the board.



Figure 5.3.7 – Front View of the Bottom Portion of the EasyDriver Board

Like before, going from left to right, GND represents ground, +5V is a 5 Volt output that can be used to power other pieces of hardware. SLP is a logic input that disables outputs, thus minimizing power. MS1 is a logic input that is used to set the stepping resolution of the motor. We have another GND pin that represents ground, STEP is a logic input that acts as edge-trigger, meaning a change from low to high logic will cause the motor to rotate one step. Other parameter of the step, such as step size and step direction, are controlled by MS1 and MS2, which have been explained and by DIR which is a logic input used to control the direction of the motor. Other information to consider includes controlling the step size of the motor. Using stepper motors, we can use microstepping to create a smooth motion for rotating the solar panel. We can set the resolution of the stepper motor by using the MS1 and MS2 pins. Table 5.3.4 below shows a truth table of values for MS1 and MS2 to achieve the desired step resolution.

Microstep Select Resolution Truth Table

MS1	MS2	Microstep Resolution
L	L	Full Step (2 Phase)
H	L	Half Step
L	H	Quarter Step
H	H	Eighth Step

Table 5.3.4 – A Truth Table to Determine with Respect to MS1 and MS2

Next we can discuss the two solder jumpers on the board. Both solder jumpers allow the user to control the voltage that can be used to power external hardware. The first solder jumper, labeled 3/5 V, allows a user to configure V_{cc} to be either 5 or 3.3 V where the other solder jumper, labeled APWR, allows the user to configure whether V_{cc} can be used to power external hardware. Figure 5.3.8 shows the 3/5 V and Figure 5.3.9 shows the APWR pins of the EasyDriver board.



Figure 5.3.8 – The 3/5V solder jumper



Figure 5.3.9 – The APWR solder jumper

To wrap up our discussion of the EasyDriver motor driver, we will discuss the potentiometer, which is crucial to prevent motor damage. Figure 5.3.10 showing the potentiometer on the EasyDriver board.



Figure 5.3.10 – The Potentiometer on the EasyDriver Board

The potentiometer will allow us to control the current that will flow through the coils of the motor, thus allowing us to prevent damage arising from using too much current. The achievable current ranges from 150 - 750 mA, so by rotating the potentiometer in small steps we can the 500 mA that we require to power the

motor. To test the current, we can connect a resistor of known resistance R to the pair of pins A and measure the current directly using a multimeter. Doing this will allow to us to tune the potentiometer to the correct current setting. As a result of this, we can use a higher than rated voltage for the motor, which would improve its moving torque, while limiting the current through the motor coils to provide a stable and efficient motion control. Now that we have discussed the motor driver and its components, we can continue with a discussion of the motors and the mechanical structure that we will use to hold and rotate the solar panel.

5.3.5 Structural Considerations and Motor Design

For the solar tracker, we need to design and build a mechanical structure that will hold the solar panel, as well as provide a way to rotate the solar panel in two axes. For the full-scale design, we are collaborating with an Art team and a Mechanical and Aerospace Engineering (MAE) team to build the structure that will hold our solar tracker. As for our 1/8 scale prototype, we have come up with two designs, both of which utilize the idea of panning and tilting to achieve our desired dual-axis functionality for our solar tracker. The approach that we used to reach a conclusive design involves analyzing the torque on our system with respect to the holding torque of the motors. In order to explain our overall design, it will be beneficial to explain the motive behind our design. When selecting our motor, we had to be very cautious about whether our motor could provide the proper support to hold our solar panel in place. Thus, our motor has to have enough holding torque with respect to our design. To see this, we calculated the amount of torque required when the solar panel was in a position where the maximum amount of torque would be exerted against the motor. Figure 5.3.11 below shows this situation.

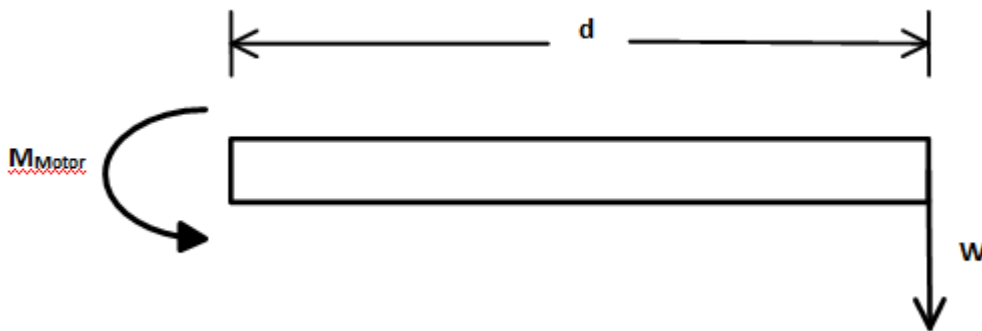

Figure 5.3.11 – Moment Analysis Diagram of the Holding Torque vs. Solar Panel Weight

We formed the equation that relates the holding torque of the motor to the weight of the solar panel using the equation below:

$$\sum M = 0,$$

using counter-clockwise as our positive convention, we came up with the following equation:

$$\sum M = 0: M_{Motor} - (W_{SP} * d) > 0,$$

where M_{Motor} is the holding torque of the motor, W_{SP} is the weight of the solar panel, and d is the distance between point O (where the motor is located) and the solar panel. The holding torque for the motors that we selected is 32.6 oz.-in. and the known weight of a solar panel that we currently have access to is 11 lb. After converting lb to oz and solving for d we get the following acceptable range for d :

$$d < 0.1852 \text{ inches}$$

Looking at this value, it is not a very reasonable distance to work with. Also, since we neglected the weight of the structure in our analysis, this design would not work with our current selection. Another design focuses on minimizing the distance between the motor and the center of gravity of the solar panel in order to provide some sort of counter-balancing using solely the weight of the solar panel to minimize the amount of net torque that the motor has to deal with during rest and movement phases. This design will implement two stepper motors: one stepper motor rotates the solar panel around the axis perpendicular to a horizontal surface while the other stepper motor rotates the solar panel around the axis parallel to the same horizontal surface. Together, these two stepper motors create a pan-tilt mechanical configuration to realize our two-axis solar tracker. Since the stepper motor will be rotating the solar panel about its center, the weight of the solar panel will be able to lessen the stress on the motor, thus allowing for a small, affordable stepper motor with respect to the size of the solar panel. To finish our discussion of the motor subsystem, we will show the design schematics for the motor subsystem and discuss how the different components in the subsystem will interact with each other.

5.3.6 Motor subsystem schematics

To start, Figure 5.3.12 below shows the schematic of our MCU. The four light sensors will be connected four analog pins in the ATSAM21G18 MCU. From here, we will read in the voltage from the light sensor configurations to determine where the most light is striking the solar panel. For the stepper motor drivers, five digital pins will be needed for each driver, resulting in a total of ten pins required to drive the stepper motor.

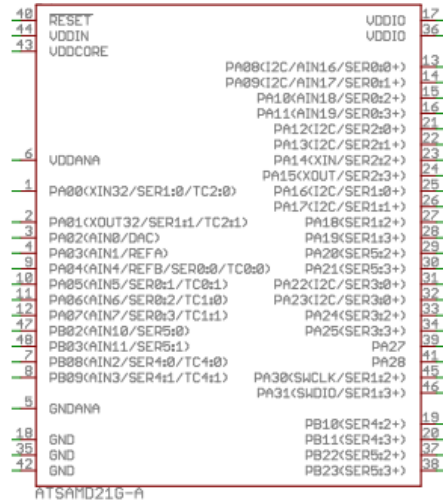

Figure 5.3.12 – Schematic of the ATSAM D21G18 MCU

Other analog and digital pins will also be required for the other subsystems of this design, which will be discussed in the other sections of our design document. Before moving on to the motors and motor drivers, we need to discuss the clustering of the pins. For prototyping, we are using the SAM D21 Breakout Board from SparkFun to test our design. When sourcing and sinking current from the MCU, each of the pins can source up to 7 mA and can sink up to 10 mA, with one exception: Each cluster of pins can cumulatively source 14 mA and can sink 19.5 mA. Table 5.3.5, displaying the clusters of pins and their corresponding grounding pins, is shown below.

Cluster	GPIO	Cluster Supply (Pin)	Cluster Ground (Pin)
1	SWCLK, SWDIO	VDDIN (44)	GND (42)
2	30, 31 (USB_HOST_EN, TX_LED)	VDDIN (44) VDDIO (36)	GND (42) GND (35)
3	D2, D5, D6, D7, D10, D11, D12, D13, D38 SCL, SDA, MISO, SCK, MOSI (USB_D-, USB_D+)	VDDIO (36) VDDIO (17)	GND (35) GND (18)
4	D0, D1, D3, D4	VDDIO (17)	GND (18)
5	A1, A2, A3, A4 D8, D9	VDDANA (6)	GNDANA (5)
6	A0, A5, AREF (RX_LED, RTC1, RTC2)	VDDANA (6)	GNDANA (5)

Table 5.3.5 – Clustering Table of Pins for the SAM D21 Breakout Board

Looking at the figure above, we can see that there are six different clusters of pins. Most of the digital pins are clustered together and the analog pins are almost evenly clustered together. We will need to take this clustering into consideration when connecting the peripherals to the MCU in order to prevent unexpected behaviors from our system. Next, we can start to discuss the schematics of the EasyDriver stepper motor drivers and the stepper motors. First, let us take a look into the stepper motor driver. Figure 5.3.13 below is the schematic of the EasyDriver stepper motor drivers.

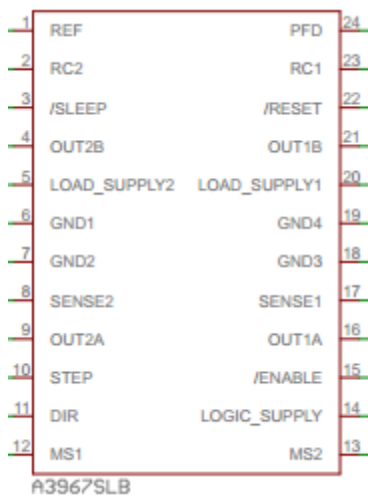

Figure 5.3.13 – Schematic of the Easy Driver: Stepper Motor Driver

Each stepper motor driver will connect to five digital pins from the ATSAMD21G18 MCU in order to receive the proper signals from the MCU so that the stepper motor driver can send the correct sequence of current to the stepper motor to produce a continuous, rotational motion. The pins that will connect to the MCU are MS1, MS2, STEP, DIR, and ENABLE. MS1 and MS2 are logic inputs which will configure the step size of the stepper motor depending on the combination of low and high logic for the two pins. DIR sets the direction of the stepper motor. STEP is an edge-triggered logic input that will rotate the motor one step. ENABLE is a logic input that allows or prevents motor control. When ENABLE is set to low, the driver will be able to control the motor. From here we will then connect the stepper motor drivers to their respective stepper motors. The electrical diagram of the 4-lead NEMA 14 stepper motor that we will be using is shown below in Figure 5.3.14.

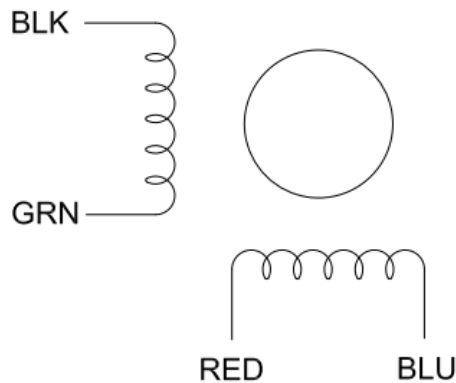

Figure 5.3.14 – NEMA 14 Stepper Motor Connections

The stepper motor driver has four pins to connect to the stepper motor: OUT1A, OUT2A, OUT1B, and OUT2B. For the connections between the stepper motor driver and the stepper motor, we need to connect the A pair of pins to the ends of one coil and the B pair of pins to the ends of the other coil. To be explicit, we will connect OUT1A from the stepper motor driver to BLK of the stepper motor, OUT2A to GRN, OUT1B to RED, and OUT2B to BLU. From here, the MCU will be able to read in the data from the light sensors using the analog pins. Using this data, we can determine how to move the solar panel in order to have it face the sunlight directly. Once this is determined from the data, the MCU can then send the proper control signals to the stepper motor drivers so that the current can be sequenced correctly for the stepper motors.

Lastly, we will discuss the electrical configuration and schematic of the light sensors that we will connect to the MCU. The schematic for the light sensor is shown below:

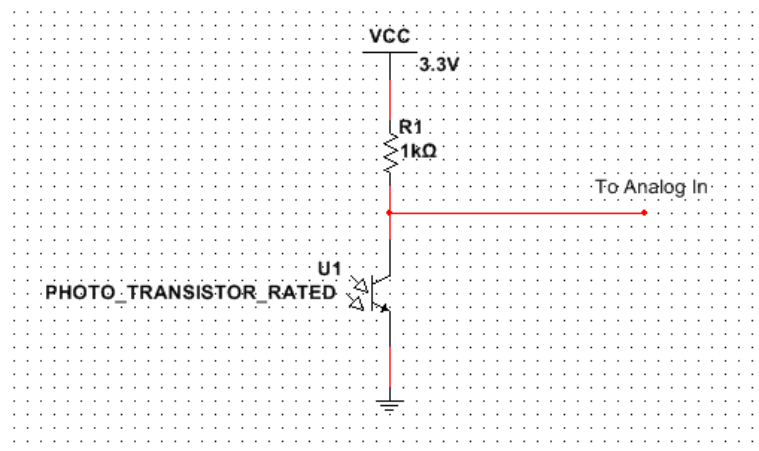

Figure 5.3.15 – Electrical Schematic for the Light Sensor

The light sensor will connect to the VDDIN pin from the MCU so that current will run through the the sensor circuit. The voltage coming out of the pin will be 3.3 V, so that with a resistor of 1 k Ω , the maximum current running through the resistor can be determined using Ohm's law:

$$V = IR,$$

Where V is the voltage across the series combination of the resistor and phototransistor, I is the current through the resistor, and R is the resistance of the resistor.

$$I = 3.3 \text{ V} / 1 \text{ k}\Omega,$$

So, the maximum current running through the resistor, theoretically, can be 3.3 mA when the phototransistor is fully allowing the current to run through to the ground. Realistically, this value will be much lower since, even with direct sunlight hitting the phototransistor, some current will not be allowed to flow through to ground. With four light sensors, we would be sourcing about 13.2 mA from the MCU, which will be possible using the cluster containing pins A1, A2, A3, and A4. Using the above schematics, we can create the motion subsystem needed to control the movement of the solar panels to achieve maximum power efficiency.

5.4 Wireless Information Transmission Subsystem

The current and voltage sensors will supply the raw data which will be transformed by the ATSAM21G18 microcontroller in a quantifiable amount of solar power harvested up to that particular moment. Then, the microcontroller, acting as a web client, will send a POST request to the web server running a custom database and a PHP application. The web server will store the information which will later be accessed by the website. Figure 5.4.1 shows the flow of data from its birth to its final destination

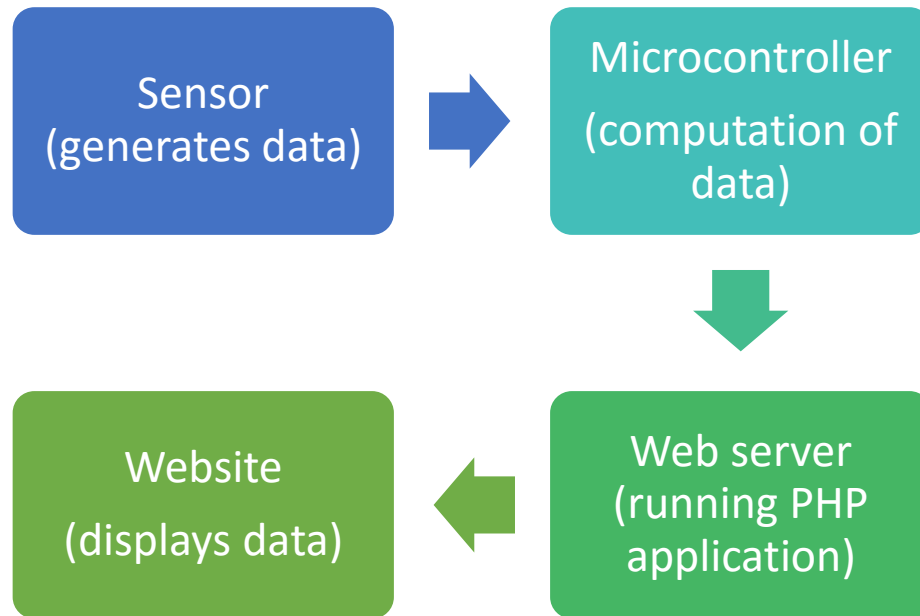

Figure 5.4.1 - Flow of Data Diagram

5.4.1 Microcontroller Connection to Server

The ATSAM21G18 microcontroller will be connected to the ATWINC1500 Wi-Fi module to be able to send information online. This is done by first connecting the Wi-Fi module to a Wi-Fi router for network connectivity. After this, the server needs to be configured and the data needs to be sent. When all of this is done, the microcontroller needs to command the Wi-Fi module to close the connection.

The ATSAM21G18 will be programmed using the Arduino interface. The code will contain a conditional statement in which the MCU tries to connect to the web server using its address. If it connects successfully then the code in the conditional statement will execute and the data will be sent using print functions from the Wi-Fi library.

5.4.2 Web Server

The web server will run from an EC2 on AWS in a Linux environment. It will run a custom database based in MySQL and a PHP application. The database is used to store the values for power generated by the solar panels using the current and voltage sensor readings. This database will consist of only one table with 3 columns. The first column will be the ID of the data row. The second column will be for the time stamp, while the third will be for the power generated up to the time displayed in the time stamp column. The current and voltage will be used by the MCU to calculate the power generated by the solar panels.

The PHP application will include three files: connect, add and index. The file connect will be loaded every time the MCU needs to access the database. Also, this file has the function that returns a new connection which will be needed when the PHP application sends a query to the database. The file add will be used when the MCU sends POST requests to the server. The PHP application executes an insertion query with the values received from the microcontroller. Finally, the index file will be the one that links to the website and displays the values contained in the database. Figure 5.4.2 shows the files contained in the PHP application that our web server will be running.

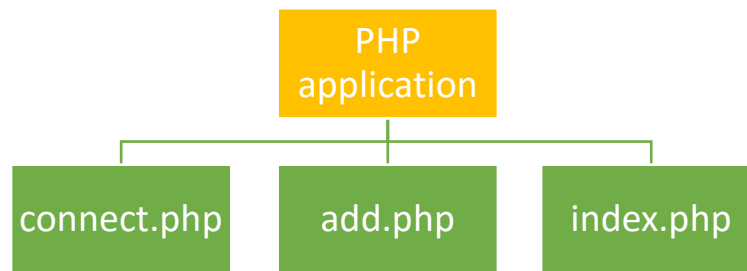

Figure 5.4.2 - PHP Application Files

5.4.3 Website

The website is very important because it allows the public access to the information on how much energy the solar sculpture harvests from the sun. It does this by displaying in an understandable way the data collected; which is a requirement given to us by our sponsor. The website will have a server that will store the most current data sent from the microcontroller inside the solar sculpture.

This website interface will be written in HTML and CSS. A front-end responsive framework will be used to make the process of development smooth and efficient. A framework is a package made up of files and folders of standardized code which is used as a basis to start building a site. The website will be fully accessible across all devices, which will allow it to reach a bigger audience. The home page will display a welcome message and a menu bar or dropdown depending on what devices is being used by the user. The menu will include links to the statistics page, the learn more page, the gallery page and the OUC website. The color palette used in the website will include light greens and yellows to reflect the environmental/solar energy concepts that this project is based on. The font stack will use Google Fonts, with the primary font being Open Sans. A fall back font should be used if the user doesn't have access to the primary font. This font will

be generic sans-serif. Below Figures 5.4.3 and 5.4.4 display the mobile and desktop versions website mockups.

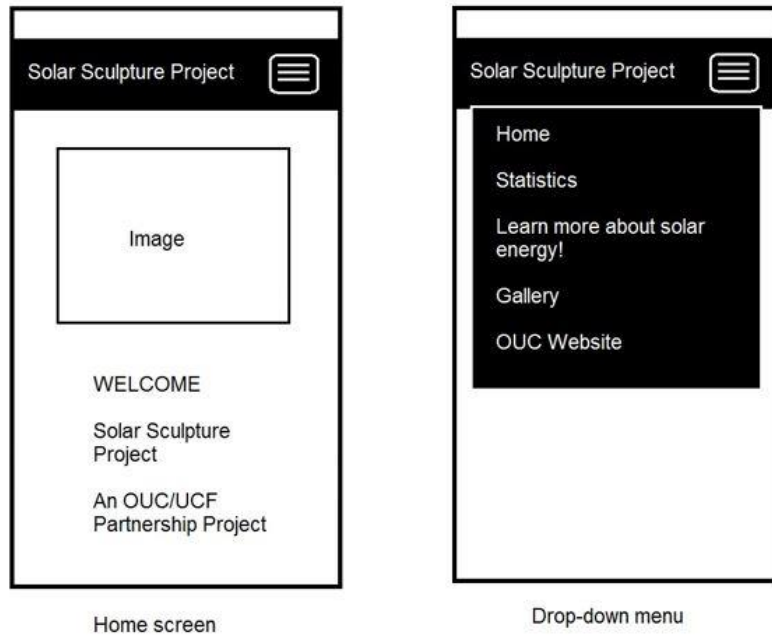

Figure 5.4.3 - Drop Down Menu and Home Screen

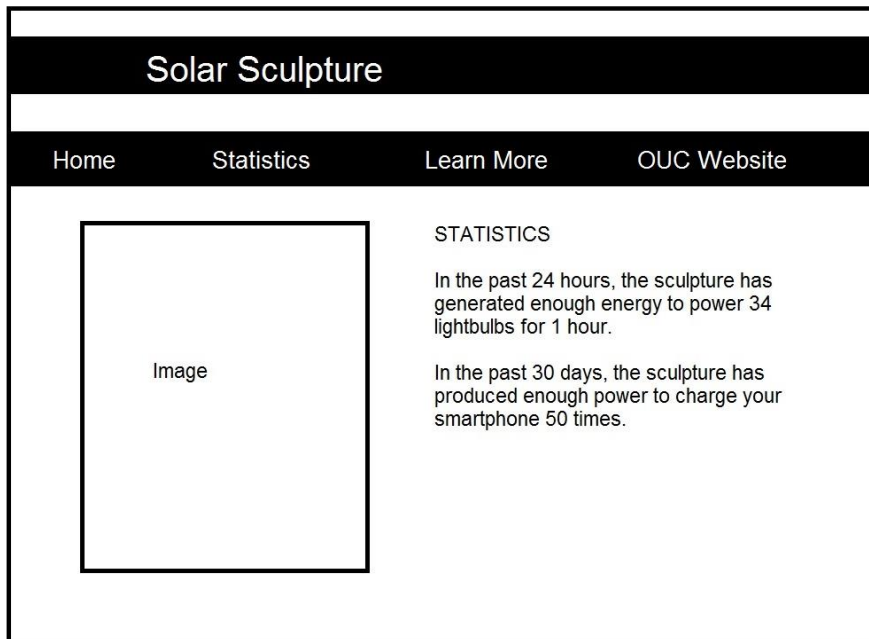

Figure 5.4.4 - Desktop Version

5.4.4 Wireless Module Hardware

The Adafruit ATWINC1500 Wi-Fi breakout board communicates using Serial Peripheral Interface (SPI) which enables the exchange between two devices (master and slave). The exchange is a serial exchange which means that the transfer is done one bit at a time. SPI operates in full duplex mode, which implements the bidirectional transfer of data at the same time. The most significant advantage of having a wireless module that supports serial communication over the ones that support parallel interfaces is that the system will require simpler wiring. In this case we will need about 6 or 7 wires.

Also, the ATWINC1500 supports SSL, Secure Sockets Layer, which establishes an encrypted link between a server and a client. SSL is frequently used between a web server and a browser and it allows the safe transmission of sensitive information. WEP, WPA and WPA2 are supported by the ATWINC1500 as well. This protocols adds a good level of encryption to the wireless transmission subsystem of our project.

This breakout board incorporates level shifting on all the input pins so it can be used with 3V or 5V logic. There's also 3 LEDs that can be programmed over the SPI interface or with the Arduino library to light up when the Wi-Fi module is connected to an SSID or transmitting data. Table 5.4.1 lists all the Wi-Fi module's specifications that will be of great help when constructing the schematics for our project.

Specification	Value
<i>Typical Operating Voltage</i>	3.3V
<i>Minimum Voltage</i>	2.7V
<i>Maximum Voltage</i>	3.6V
<i>RX Current</i>	70mA
<i>TX Current</i>	172mA
<i>Standby Current</i>	380uA
<i>Sleep Current</i>	4uA
<i>I/O</i>	14 Digital I/O Pins
<i>Communication Protocols</i>	DHCP, DNS, TCP/IP (IPv4), UDP, HTTP
<i>Transmission rate</i>	Up to 72 Mb/sec
<i>Price</i>	\$24.95

Table 5.4.1 – Wi-Fi Module Specifications

The ATWINC1500 by Adafruit comes in a breakout board which we will use for our actual implementation because it comes with the antenna that the module requires

in order to work. Figure 5.4.5 shows the pins that the Wi-Fi breakout board offers its users. Vin is the pin that takes the power-in. It can be connected to a voltage that can range from 3.3VDC to 5.5VDC. Also, the ATWINC1500 can draw up to 300mA when it is transferring information so we have to make sure our battery will be able to supply this power. The GND pin is the ground for both signal and power. The SCK pin is for the clock input which is compliant with either 3V or 5V. The MISO pin transfers the data out from the module while the MOSI pin transfers data into the module. The MISO pin takes 3.3V while the MOSI one is 3V or 5V compliant. The CS pin is the chip select pin in case the user need to use several chips. This pin is pulled by default to Vin with a 100K resistor. The EN pin enables the whole module. It is tied low by default with a 100K resistor but when building our prototype we should tie it to a 3-5V to keep the module on all the time. The IRQ needs to be connected to the microcontroller's INT input line. This pin handles interrupts from the Wi-Fi module. The RST pin is the module reset pin. It is tied to low with a 100K resistor. The WAKE pin is used to wake up the module when it is in sleep mode. The CFG pin allows you to select either SPI or UART data transport. SPI is the default and if the user won't work with UART then this pin can remain disconnected. The RXD and the TXD are also used by the UART to transport data. In our project this pins will remain disconnected as well.

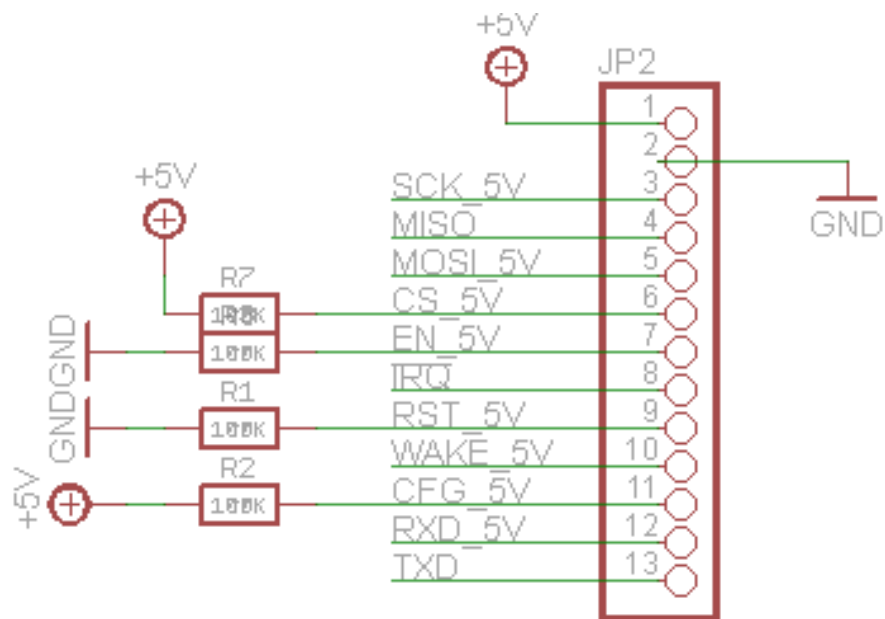

Figure 5.4.5 – WiFi Module Pin Layout

Besides the pin layout of the breakboard, it would be useful to understand the pin layout of the actual Wi-Fi module. The specific model of the module for this breakout board is the ATWINC1500-MR210P. Figure 5.4.6 has the pin assignment

for it. GPIO_3, GPIO_4, GPIO_5 and GPIO_6 are general purpose I/O pins. I2C_SCL is a pin for the slave clock and is only used for Atmel debug. I2C_SDA is used for slave data. This pin is also only used for Atmel debugging. The RESET_N pin is an active-low hard reset pin. This means that when this pin is asserted to a low level, the module will enter a reset state. When this pin is asserted to a high level, the module will run conventionally. The ATWINC1500-MR210P module also contains 4 NC pins. NC stands for no connect and this pins were probably included in the design of the module for economic or efficiency reasons when buying the package where the design of the module will be implemented. The GND_1, GND_2, GND_3 and PADDLE pins work as ground. The SPI_CFG pin enables the SPI interface and it is tied to VDDIO through a 1M resistor. The Wake pin is used to wake up the module from Doze mode. It needs to be connected to a host GPIO. The IRQN pin is the ATWINC1500-MR210P device interrupt output. This pin will connect to the host interrupt input pin. The UART_TXD pin transmits output from the module. The SPI_RXD pin is the Master Out Slave In (MOSI) pin. The SPI_SSN works on active low and it is the SPI's slave select pin. The SPI_TXD is the Master In Slave Out (MISO) pin. The SPI_SCK is the SPI clock. The UART_RXD is the UART receive input. VBATT is the battery power supply pin. The GPIO_1/RTC pin works as a general purpose I/O pin. The CHIP_EN pin is the module enabler. It is connected to a host output that defaults low at power up. High level enables the Wi-Fi module and low level places module in Power Down mode. VDDIO is the input/output power supply pin. This pin must match the host's I/O voltage. Finally, the 1P3V_TP pin must be left unconnected since it is a VDD core test point.

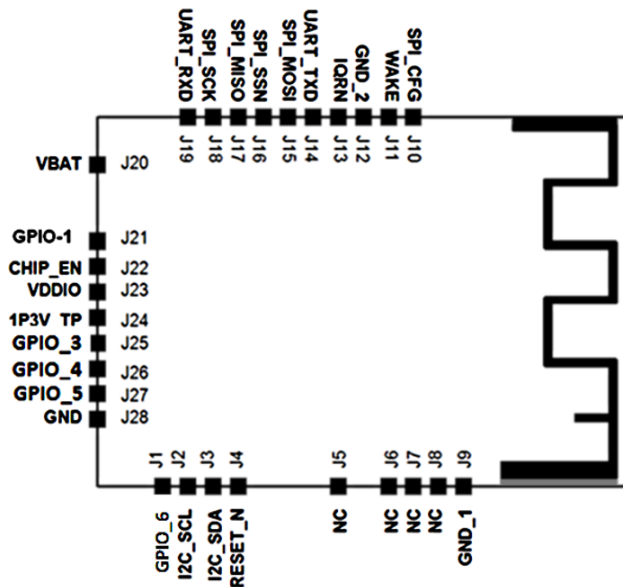

Figure 5.4.6 – WiFi Module Pin Assignments

In conclusion, the Wi-Fi breakout board will need nine connections to function properly: eight connected to the microcontroller and one connected to a common ground. The pins connected to the microcontroller's 3.3V or 5V power supply pin will be Vin and EN. SCK will be connected to the SPI clock. MISO will be connected to the SPI MISO. MOSI will be connected to the SPI MOSI. CS, IRQ and RST can be connected to any digital I/O pin. Finally, the GND pin will be connected to ground.

6.0 Project Prototype Construction and Coding

6.1 Parts Acquisition

6.1.1 Parts Distributors and Resources

Texas Instruments is one of the largest companies for electrical embedded systems parts; a number of our parts are manufactured by TI. We will utilize the datasheets for these parts to assist in our assembly and design. Also, many tools we have and will use, like Webench, were developed by TI.

Digi-Key is an electrical parts vendor with a vast catalog. Many of our parts have been purchased through this site. Each part has its own page with links to the datasheet and other resources we will be utilizing. Also, the prices found here are often the best-found prices.

SparkFun Electronics is a distributor for hobbyists and other customers who are looking to purchase electrical components and parts. The parts sold on this site are used in subsequent project and tutorials making it a hub for budding hobbyists and engineers. Many of the tutorials have been used as examples and starting points for this team. Also, this site is where the microcontroller SAM D21 has been purchased and will be utilized throughout our project.

Adafruit is a distributor similar to SparkFun. They are ranked #11 in the top 20 USA manufacturers. They have a vast catalog of projects and tutorials that were used as a starting point for this team and our project. Some of our parts were ordered from this retailer. We will be utilizing their site as a resource throughout our project.

6.1.2 Parts and Components

The picture below in Figure 6.2.1 shows all the components we are currently using to prototype our design. The stepper motors will be used to implement dual axis tracking using the mount shown. The microcontroller and drivers are also part of the tracking. All of the components on the breadboard are part of the maximum power point tracker/charge controller except for the current sensor. The current sensor will be part of the power measurement. Not all the resistors or filtering capacitors are shown because we will be using the senior design lab's stock in our

prototype. We will, however need to order the surface mount version of these components for our printed circuit board.

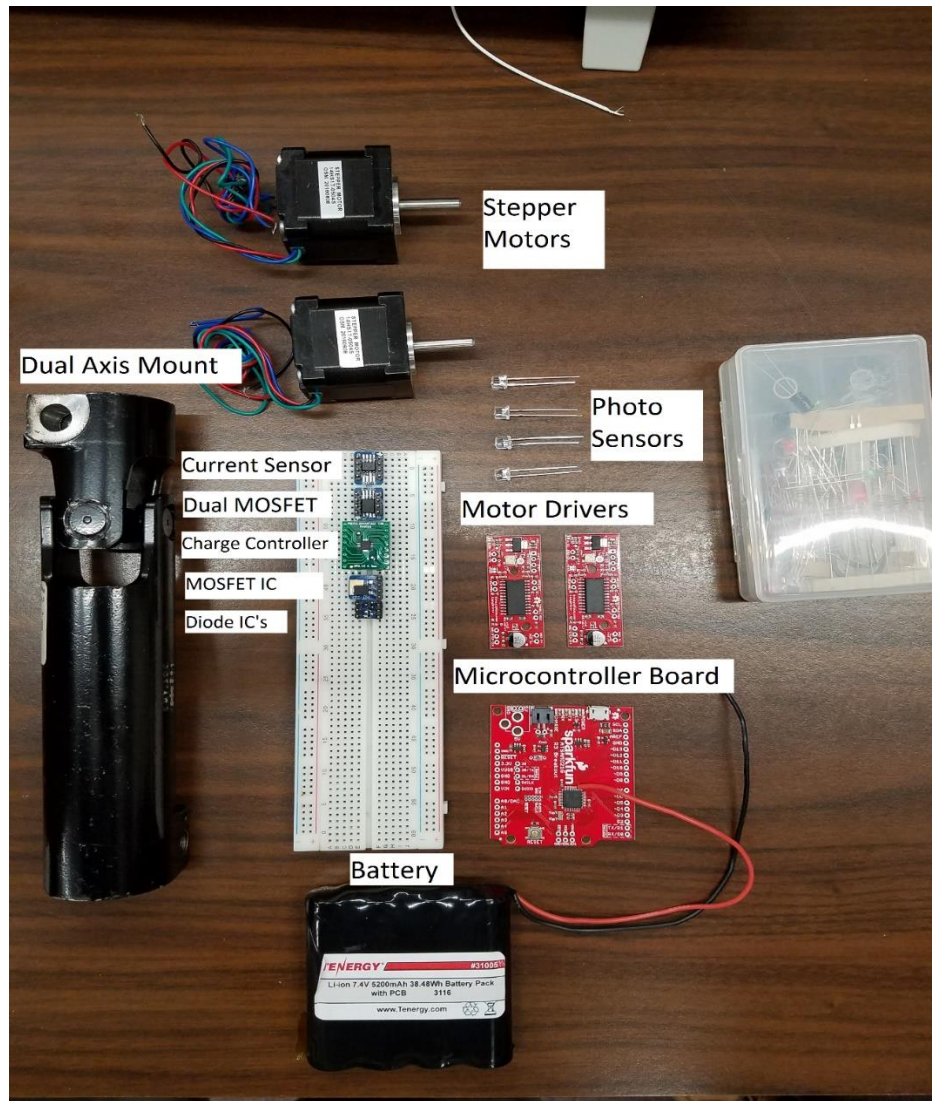

Figure 6.2.1 – Components for Our Project

6.2 PCB Vendor and Assembly

6.2.1 PCB Manufacturers

There are several vendors that provide PCB services. In this section, we will discuss some vendors and their quality.

PCB Way is a vendor based in the China, with over a decade of experience in prototyping and fabrication. To verify the quality of their boards they visually check and electrically test to ensure the board complies with the given Gerber files. They have an on-time delivery rate of 99% and work in three shifts to ensure quick turnaround. Their prices for their boards are low and very competitive.

Sunstone Circuits is a vendor based in the United States out of Oregon, with over 40 years of experience in the industry. They supported RoHS with the addition of an immersion silver offering. They utilize DFM manufacturing check tools and a 25-point DFM review. Also, their customer service is available 24/7/365. They have over 99% on-time delivery rate and they guarantee the quality of their boards.

Advanced Circuits (4PCB) is a vendor that is based in the United States with over 20 years in the industry. They are ranked 3rd among the top circuit board fabricators in North America. To ensure quality, all orders receive a free engineering file review before being fabricated. There is no minimum quantity for ordering from 4PCB. Also, they claim to have the best on-time shipping record.

Imagineering Inc. is a vendor based in the United States with over 27 years of experience in the industry. They claim every one of their boards meet IPC-A-600 F standard (also known as Class 2). They promise to deliver “per spec” and on time.

6.2.2 Project Construction Resources

There are a few resources we have and will be utilizing for the construction of our prototype. We will discuss some of these resources below.

ECE Senior Design Lab is located on the fourth floor of the Engineering I building. Currently we have been using this space to meet as a group and check in to our individual progress. In the future this lab and the equipment inside will be utilized to build the prototype.

UCF Radio Club is a group that has experience in building and soldering all kinds of electrical parts. They are located in the back of the Senior Design Lab. This group has taken the time to assist some of our members by instructing them on using the soldering hot air tool. They also allowed our team members access to their equipment, which includes a soldering iron and hot air tool.

TI Innovations Lab is a lab located in the Engineering !! building on the UCF main campus which provides students access to soldering irons, soldering hot air tools,

workspaces, and many other equipment; the lab is monitored by trained advisors. We have and will utilize this space to solder our parts and work on our project.

MAE Senior Design Studio is located on the third floor of the Engineering I building. This space provides individualized cubicles for MAE teams to meet in. We have utilized this space to meet with our partnered MAE team and their advisors. Here we discuss the MAE part in the design, any presentation we may present collectively, and our portion of the design that will need MAE assistance.

6.3 Final Coding Plan

The code on the microcontroller will be complex and it will have a diverse functionality since it has to communicate with several devices at the same time. The communication with the light sensors will allow the microcontroller to calculate the optimal position for the solar panel to receive sunlight directly. The communication with the motor controller will allow the microcontroller to move the solar panel frame to the calculated optimal position. The communication with the voltage and current sensors will provide the microcontroller with the raw data needed to calculate total power generated by the sculpture. Finally, the communication with the Wi-Fi module will allow the microcontroller to connect to the Internet and send the calculation to the web server. All of these communications are essential for the solar sculpture prototype to work optimally.

The solar sculpture prototype will perform each of its tasks autonomously. Figure 6.3.1 shows the microcontroller's code state diagram. Once it has been turned on, it'll start the process of initialization which includes setting up the wireless network connection and initializing the variables that will be used later in the code. Then, the microcontroller will make sure that the sensors are connected and that the microcontroller can read them. If the microcontroller finds any problems with the sensor connection, it will execute the sensor error subroutine which includes blinking a LED light. This is mainly to provide the developer with a visual clue during the debugging process. After this, the microcontroller will check its wireless connectivity because it would be problematic to start executing the Main routine if the information can't be sent to the website. After the tests, the microcontroller will execute the main routine which involves getting readings from the light sensors and calculating the new optimal position for the solar panel. If the new calculated position is different from the old position, the microcontroller will call the motion subroutine which will rely on the motor controller to do the movement of the solar panel frame. Finally, the microcontroller will check if it has been 5 minutes since it last restarted the timer. If it has then it will call the wireless communication subroutine which will get data from the current and voltage sensors, calculate the total power generated by the sculpture and connect to the web server to send this

information. The wireless communication subroutine will also restart the timer and yield to the Main function for another loop execution.

The ATSAM21 is compatible with the Arduino libraries. Therefore, our microcontroller's code will be written using the Arduino IDE which uses its own programming language. This language is a C/C++ dialect and the libraries are under the LGPL. It is called a dialect because the language derives from C and C++ but most of the standard libraries won't work because the Arduino language has extra restrictions due to the little available RAM on the Arduino hardware. Arduino programs can be divided into three main pieces: structures, values (variables and constants) and functions. The structures will include functions such as setup() and loop(). Structures are composed of control structures, arithmetic operators, comparison operators, Boolean operators, pointer access operators, bitwise operators, compound operators and further syntax. The variables include constants, data types, conversion functions, variable scope and qualifiers and utilities. The functions include digital I/O, analog I/O, due and zero only functions, advanced I/O, time functions, math functions, trigonometry functions, character functions, random number generators, bits and bytes functions, external interrupts, interrupts, communication functions and USB functions.

The functionality of our solar sculpture prototype can be divided into three parts: setup, testing and autonomous mode. The setup code for the ATSAM21 will be setting up the connection between the microcontroller and the Wi-Fi module. When the microcontroller is turned on, the module is initialized and it connects to the internet. Since this prototype was designed for a system that will be placed in a static sculpture, the wireless network name and password can be hardcoded into the microcontroller's code. This is because the wireless network that the solar sculpture access will be the same one for long periods of time. The code on the ATSAM21 will be very linear since it basically consists of a series of simple steps to be executed for setup. This portion of the code will only run when the microcontroller has just turned on.

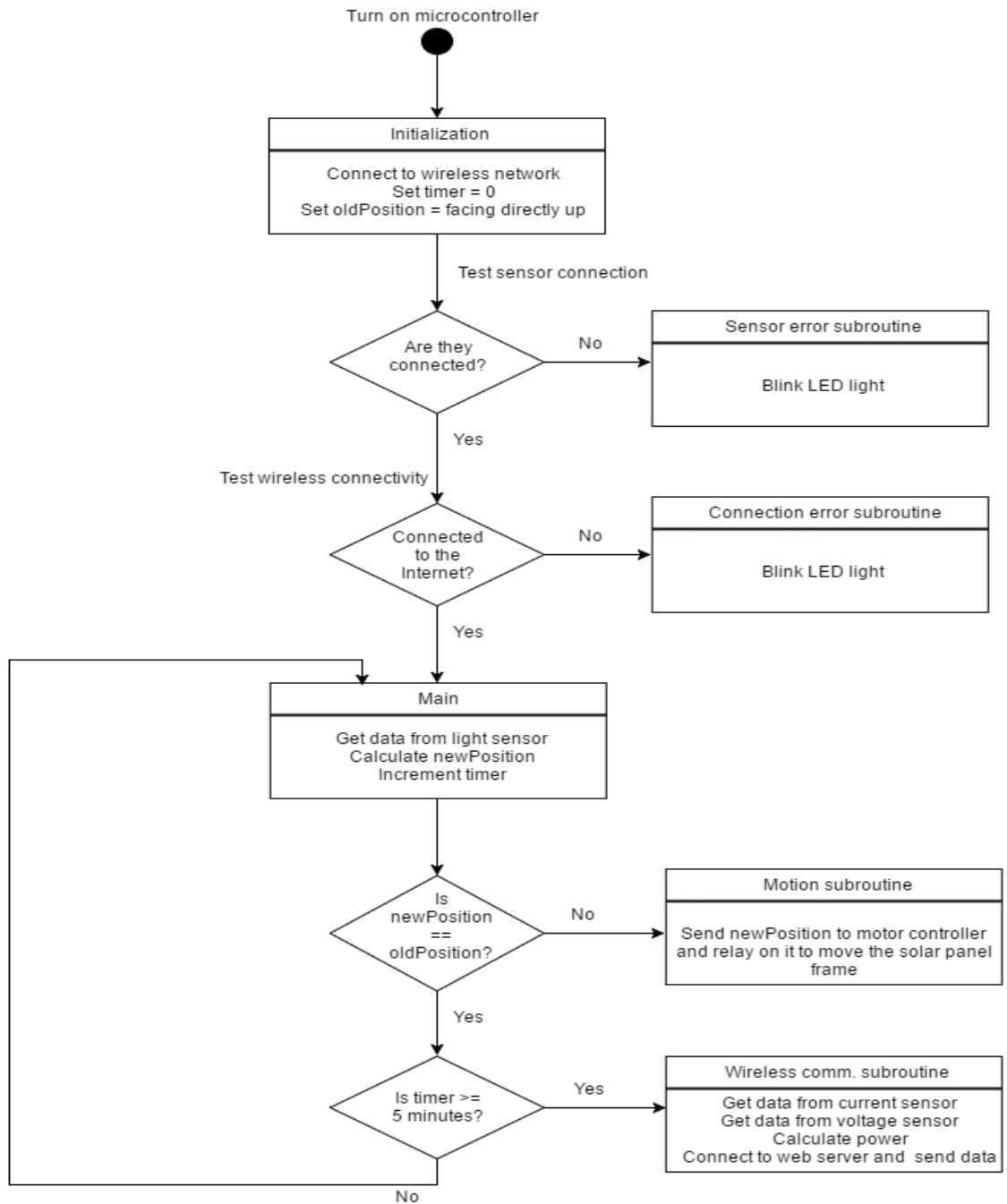

Figure 6.3.1 – Microcontroller's Code State Diagram

The testing part will execute after the microcontroller is done with the setup part. This part is very important since it prevents the microcontroller from reading data from sensors that aren't properly connected and from trying to send calculations to a web server without a wireless connection to the internet. Basically, this section

of the microcontroller's code increases the efficiency of the overall code by preventing wasting the power on performing tasks that can't be concluded because they're missing an important component. The testing part communicates the developer that the connection to the sensors or the wireless couldn't be completed by blinking the LEDs. The LEDs can be two different LEDs with different colors for the two subroutines or it can be one LED that blinks at different paces depending on which error subroutine was called. An example of this would be blinking fast (every 0.5 seconds) for the connection error subroutine and blinking slowly (every 1 second) for the sensor error subroutine.

After the two parts described above have executed, the microcontroller will loop over the autonomous mode part until it is powered off. This is the part that is meant to execute for the longest time since the prototype and the actual-sized solar sculpture are meant to be outside performing the solar tracking constantly. The autonomous mode part consists of three subsections. The first one handles the solar tracking by obtaining information about the coordinates of maximum light and calculating the new position that the solar panel would have to be in to maximize the absorption of solar energy. The second section compares the new position with the old one and moves the motors accordingly. The third section checks if the timer has expired to execute the wireless communication subroutine in which the microcontroller gathers information from the current and voltage sensors and sends it to the web server to be displayed on the website. This section is also responsible for calculating the power absorbed using the readings from the sensors and restarting the timer. A timer will be used in this case because it isn't necessary to send the power absorbed in every loop iteration. Obtaining a reading every five minutes will give us enough information on the performance of the solar sculpture prototype.

7.0 Project Prototype Test Plan

Testing is very important to ensure functionality and quality in our prototype of the solar sculpture. In the following sections, we will describe each test case by listing its objective, equipment needed, the procedure to execute the test and the expected result. In order to make sure each subsystem works as expected before integrating them as a whole, we will test them individually. After doing this, we will integrate them together and test the entire system.

7.1 Hardware Test Environment

The testing environments where the hardware test will be performed are the Senior Design Lab in the 4th floor to the Engineering 1 building, the TI Innovation Lab, team members' places of residence and different outdoor locations throughout the UCF campus. Also, the system and subsystems will be tested at the actual location of where the sculpture will be placed in order to test Wi-Fi connectivity and light conditions. The Senior Design Lab and the TI Innovation Lab will be used to test the electrical components due to the great availability of electrical equipment. Finally, the overall functionality of the hardware will be tested at the home of the team member that currently has the project in his or her possession.

7.1.1 Sensors Tests

Test Name: Light Sensor Test

Objective: The objective of this test is to verify that each light sensor is able to measure the intensity of visible light.

Equipment:

- Adafruit 2831 sensor x4
- Multimeter
- Breadboard
- DC power supply
- Candle

Procedure:

1. Verify that the Adafruit 2831 sensor is connected to the breadboard.
2. Light the candle.
3. Place light sensor 2 feet away facing the candle.
4. Measure the output voltage while moving your hand slowly crossing the direct pathway between the light sensor and the candle.

Expected Result: The voltage output will change as the hand in front of the candle blocks the light from the sensor.

Test Name: Current Sensor Test

Objective: The objective of this test is to verify that the current sensor works properly and it measures the amount of current that is passing through that sensor.

Equipment:

- ACS711KLCTR-12AB-T sensor
- Breadboard
- DC power supply

Procedure:

1. Build simple source/resistor circuit on breadboard.
2. Place sensor on circuit.
3. Manually calculate the current that should be passing through circuit and compare results with sensor output.

Expected Result: Current output should be the same as the manually calculated one.

Test Name: Voltage Sensor Test

Objective: The objective of this test is to verify that the voltage sensor works properly and it measures the voltage passing across specified components.

Equipment:

- Resistors
- Breadboard
- DC power supply

Procedure:

1. Build voltage divider circuit on breadboard.
2. Connect power source to circuit.
3. Measure voltage through the resistor and compare it to the voltage supplied to the circuit.

Expected Result: Voltage output should be equal to the voltage supplied times the voltage divider fraction.

7.1.2 Motor Controller Test

Test Name: DC Motor Test

Objective: The objective of this test is to ensure that the motor controller works with the stepper motor.

Equipment:

- Breadboard
- DC power supply
- Function generator
- Oscilloscope
- Multi-meter
- Various load resistors
- Stepper motor
- EasyDriver motor controller

Procedure:

1. Assemble circuit.
2. Verify that all circuit components are connected correctly and that the right voltages are being applied.
3. Raise the voltage from 0V to 3V very slowly on the control line.
4. Measure the PWM on the oscilloscope, the duty cycle should change.
5. Measure the two DIR lines from the EasyDriver motor controller and then change the inputs to digital ones.
6. Attach the motors and read the stall current at 100% duty cycle.

Expected Result: The range for the analog input should be from 0V to 3V for the duty cycle on the PWM. The current stall should be around 6.6 A.

Test Name: Integrated Motor Controller Test

Objective: The objective of this test is to make sure that the prototype will function properly with a load. The load will consist of the solar panel mounted on top of the prototype.

Equipment:

- Solar panel
- Battery
- Microcontroller
- Light sensors
- Stepper motor
- EasyDriver motor controller
- Various resistors

- Solar panel frame
- Flashlight

Procedure:

1. Assemble circuit.
2. Mount solar panel into its frame and place it on a flat stationary surface.
3. Adjust resistor values connected to light sensors so the sensors are able to sense light coming from a flashlight.
4. Turn flashlight on and point it at the top right sensor.
5. Take note of the movement of the motor.
6. Repeat steps 4 and 5 for each light sensor.

Expected Result: The stepper motor should be able to move the solar panel in any direction following the light coming from the flashlight. This test will also test the integration of the solar panel frame, the solar panel, the motor and the EasyDriver motor controller.

7.2 Hardware Specific Testing

7.2.1 Battery Life

Test Name: Battery Life Test

Objective: The objective of this test is to measure the battery life.

Equipment:

- Microcontroller
- Multimeter
- Timer
- Battery
- Oscilloscope
- Solar panel
- Wi-Fi module
- Light Sensors
- MPPT charging controller
- Voltage regulators
- Motor controller

Procedure:

7. Connect multimeter in series with battery, voltage regulators and motor controller.
8. Set duty cycle of microcontroller to 10% to prevent multimeter damage.

9. Measure current passing through multimeter and change the current cycle until the current needed is obtained.
10. Time how long it takes for the battery to discharge so that the motors stop running.

Expected Result: The time it takes the battery to discharge and the current it took to do it should be the same as the Battery Life chart obtained from the battery's specifications document.

7.2.2 Battery Charging

Test Name: MPPT Test

Objective: The objective of this test is to make sure that the MPPT charging controller runs the solar panel at its max power efficiency.

Equipment:

- Multimeter
- MPPT charging controller
- Solar panel
- Battery

Procedure:

1. Put the solar panel in outdoor location where it can get plenty of sunlight.
2. Connect solar panel to charging controller.
3. Connect charger controller to battery.
4. Measure the voltage of the solar panel and the current flowing in charging controller.
5. Calculate power.

Expected Result: The power calculated should be the same of the solar panel's rated maximum power. The voltage of the solar panel should be about ____ and the current going into the charging controller should be about _____.

Test Name: Battery Charging Test

Objective: The objective of this test is to verify that the battery is able to be charged by the solar panel.

Equipment:

- Multimeter
- MPPT charging controller
- Solar panel

- Battery

Procedure:

1. Put the solar panel in outdoor location where it can get plenty of sunlight.
2. Connect solar panel to charging controller.
3. Connect charger controller to battery.
4. Connect multimeter between charging controller and battery.
5. Measure the current that is going in the battery.
6. Check status of charging controller.

Expected Result: The multimeter should display a current value not too far away as the current value specified for that particular solar panel at maximum power. When the battery is charging, the charging controller should display this status, as well as when the battery has been fully charged.

Test Name: Battery Scope Test

Objective: The objective of this test is to confirm that the battery is able to withstand the full load of components.

Equipment:

- Multimeter
- Oscilloscope
- Microcontroller
- Voltage regulator
- Motor controller
- Battery
- Wi-Fi module
- Light sensor x4

Procedure:

1. Connect multimeter between battery and motor controller.
2. Make sure multimeter can handle currents of at least 15 Amps. Set duty cycle of microcontroller to 100%.
3. Measure current going into motor controller.
4. Connect multimeter in series between the 7V voltage regulator and the light sensors.
5. Write down the amount of current flowing to them.
6. Connect the multimeter in series between 3.3V regulator and microcontroller and Wi-Fi module.
7. Write down the amount of current flowing to them.

Expected Result: The current going into the motor controller should equal 13.20 Amps. The current going into the light sensors should be around 1.25 Amps. Finally, the current going into the microcontroller and Wi-Fi module should be around 200 milliamps.

Test Name: Voltage Regulator Test

Objective: The objective of this test is to verify that the voltage regulators work in order to avoid damaging our electrical equipment by passing too much current to the components.

Equipment:

- Multimeter
- Voltage regulators
- Battery

Procedure:

1. Connect the voltage regulators to the battery.
2. Connect a 10k Ω resistor to the voltage regulators circuits.
3. Measure the voltage across the two voltage regulators.

Expected Result: The voltage across each voltage regulator should be the same as its regulating value. For example, the voltage across the 3.3V regulator should be 3.3V.

7.3 Software Test Environment

The code for the microcontroller will be tested during the integration test since there's no simulation software so specific that it'll replicate our project.

We will test the website responsiveness in three different environments: smartphone, tablet and a desktop computer. The responsive framework of the website should allow it to easily migrate between these mediums. Just to make sure everything is running smoothly, we will use an Android phone running a Chrome browser and an iPhone running a Safari browser. We will use an Android tablet running its standard installed explorer browser. Finally, we will access the website on desktop/laptop computers with two different kinds of operating systems: one running MAC OS with a Safari browser and one running Windows with a Mozilla Firefox browser. This will guarantee that our website displays all of its components to a wide variety of user devices and systems.

7.4 Software Specific Testing

The wireless communication of the solar sculpture is a very important part of it because without it we wouldn't be able to inform the community and our sponsors regarding how much power our sculpture is producing. Therefore, it is imperative to verify that it works as expected in order to provide this interaction capability with the user.

7.4.1 Wireless Communication Tests

Test Name: Integrated Wi-Fi Connectivity Test

Objective: The objective of this test is to verify that the microcontroller is able to connect to a Wi-Fi gateway nearby.

Equipment:

- Microcontroller
- Wi-Fi module
- Laptop to be used as terminal

Procedure:

1. Place the microcontroller and Wi-Fi module in a place where there is Wi-Fi available and the team members know the Wi-Fi name and password to connect.
2. Modify the microcontroller's code to establish a connection with the Wi-Fi in that particular place and to display a success message in terminal if the connection was established successfully.
3. Download code in microcontroller and let it run it.

Expected Result: The terminal should display a success message.

Test Name: PHP Application Test

Objective: The objective of this test is to make sure that the PHP application will store the POST requests in the database.

Equipment:

- Laptop with internet connection

Procedure:

1. Go to <http://requestmaker.com/>
2. Fill in the form with the address of your web server and enter dummy data values as if generated by the MCU in the sculpture.
3. Click "submit" to submit the request.
4. Check database table to see if values were added.

Expected Result: Request Maker is an online tool that simulates POST request that will be made by the MCU in the solar sculpture. After this test has been completed, the table in the database should display an entry with the dummy values.

Test Name: Integrated Server Test

Objective: The objective of this test is to verify that the wireless communication in the MCU is fully able to communicate with the web server.

Equipment:

- Laptop with internet connection
- Microcontroller
- Wi-Fi module
- Voltage sensor
- Current sensor
- Breadboard
- DC power source.

Procedure:

1. Build simple source/resistor circuit.
2. Connect microcontroller to sensors and Wi-Fi module.
3. Place voltage and current sensors in circuit so they are able to read values for current in the circuit and for voltage across one of the components.
4. Turn on microcontroller.
5. Make sure Wi-Fi module is connected to the internet.
6. Check database table to see if values were added.

Expected Result: The microcontroller should calculate the power after reading the current and voltage values using the sensors. After this test has been completed, the table in the database should display an entry with the power of the sample circuit.

7.4.2 Solar Tracking Test

Test Name: Integrated Solar Tracking Algorithm Test

Objective: The objective of this test is to verify that the microcontroller is able to use the sensors to approximate the coordinates of the best position for maximum solar exposure.

Equipment:

- Microcontroller
- Light sensors x4

Procedure:

1. Place array of solar sensors in outdoor location at an angle with the perceived maximum solar exposure.
2. Modify the microcontroller's code to display in the terminal the sensor readings, current sensor coordinates and calculated sensor positions for maximum solar exposure.
3. Download code in microcontroller and let it run it.

Expected Result: The terminal should display the sensor readings. The current sensor coordinates should be different from the calculated sensor positions for maximum solar exposure. Also, the team member executing this test should have a plane of reference to verify that the calculated positions for maximum solar exposure are correct.

Test Name: Integrated Solar Tracking with Motors Test

Objective: The objective of this test is to verify that the microcontroller is able to move the motors accordingly to the calculated best position coordinates for maximum solar exposure.

Equipment:

- Microcontroller
- Light sensors x4
- Motors
- Motor controllers
- MPPT
- Arm attached to motors
- Flashlight

Procedure:

1. Place array of light sensors in dimly lit space.
2. Turn flashlight on and point the light towards one of the sensors.
3. Take note of the motion of the motor powered arm.
4. Repeat with 3 other sensors.

Expected Result: The motor powered arm should move towards the direction of the light sensor that the flash light is pointing at.

7.5 Integration Testing

Test Name: Solar Tracking Test

Objective: The objective of this test is to try out the solar tracking systems.

Equipment:

- Solar sculpture prototype

Procedure:

1. Place prototype outside at a time of day when the sun is at an angle in the sky.
2. Turn prototype on.

Expected Result: The prototype should move the solar panel towards the sun for maximum solar exposure.

Test Name: Battery Test

Objective: The objective of this test is to try out the battery life of the prototype and also to verify that it is using the solar panel to charge the battery.

Equipment:

- Solar sculpture prototype

Procedure:

1. Place prototype in outdoor location with direct sun exposure at sunrise time.
2. Turn prototype on.
3. Monitor the prototype for a full day to ensure movement during daylight hours.

Expected Result: The prototype should constantly charge its battery throughout the day. The battery should not die since it has a continuous power source. The movement of the solar panels to track the sun path should be consistent throughout the duration of this test.

Test Name: Full Integration Test

Objective: The objective of this test is to ensure the full functionality of the solar sculpture prototype.

Equipment:

- Solar sculpture prototype
- Wireless Network
- Laptop or smartphone

Procedure:

1. Place prototype in outdoor location with direct sun exposure.
2. Turn prototype on.
3. Open solar sculpture website on laptop or smartphone.

Expected Result: The prototype should be able to harvest energy from the sun to charge its battery which will power the prototype's components. Also, the solar sculpture prototype should be able to move its solar panel towards the sun with the help of the light sensors. Finally, the prototype should connect to the wireless network available in the area and send the power generated by the panels to the web server. At the end of this test, the solar sculpture website should display the solar power harvested.

8.0 Administrative Content

8.1 Milestones Discussion

Throughout the next year there will be many steps to completing our project. Below are two tables listing the tasks for each week in the semester and the date of that week for both Senior Design I and Senior Design II. Figure 8.1.1 below details the milestones for our Senior Design I semester. Some key events to note were our attendance of the boot camp and the PCB workshop. Much of our time was spent meeting with each other to discuss the project and design, as well as the mechanical engineering team and the sponsor/client.

Senior Design I		
Week	Task	Date
1	Initial Idea and Form groups	08/23/16
2	Role assignments	08/30/16
3	Initial Project Documentation	09/09/16
4	Develop Ideas	09/13/16
5	Initial Research	09/20/16
6	Attend Senior Design Boot-camp and Research Components	09/27/16
7	Further Design Discussion and Components Research	10/05/16
8	Meet ME Team and Attend PCB Design Workshop	10/10/16
9	Sponsor Conference Call and Location Visit	10/18/16
10	Write Pages based on Research and Design Discussion	10/25/16
11	Table of Contents	11/01/16
12	Senior Design Draft Document and Parts Ordered	11/08/16
13	Hardware Schematics and Software Design	11/15/16
14	Write Pages on Schematics and Software	11/22/16
15	PCB Layout	11/29/16
16	Final Senior Design Documentation	12/06/16

Table 8.1.1 – Milestones for Senior Design I

Lastly, Table 8.1.2 shown below details future tasks to be completed in the next 16 weeks in Senior Design II. Mainly this features building the prototype, testing, adjusting, and finalizing both the report and the prototype. Also, these 16 weeks will feature our integration with the art team and their structure, much of the timing on this is unknown.

Senior Design II		
Week	Task	Date
1	Art Teams Form; Build Prototype	
2	Meet with Art Team; Build Prototype	
3	Discuss Ideas with ME and Art Team; Build Prototype	
4	Art Design Chosen; Build Prototype	
5	Testing and Redesign	
6	Testing and Redesign	
7	Testing and Redesign	
8	Testing and Redesign	
9	Finalize prototype	
10	Finalize prototype	
11	Finalize prototype	
12	Finalize prototype	
13	Peer Presentation	
14	Final Report	
15	Final Report	
16	Final Representation	

Table 8.1.2 – Milestones for Senior Design II

8.2 Budget and Finance Discussion

8.2.1 Project Sponsorship

Our sponsor has provided \$30,000 to be split between the 3 groups, each group containing an art group, a mechanical group, and an electrical group. Meaning each team has about \$10,000 for the prototype. The goal for the electrical team is to stay under \$1,000 total for the prototype; this would allow both the mechanical and art departments a larger portion of the budget. The other departments have more expensive materials than our department. The full-scale design is budgeted at about \$75,000. Our portion of the full-scale design will be significantly higher

than the prototype, because we will need 3 full size solar panels and a commercial inverter which will cost a couple thousand dollars.

8.2.2 Project Spending and Bill of Materials

Again, we have placed a budget constraint on ourselves of \$1,000 for the electrical systems for the prototype. The most expensive items we have purchased in our design so far are the batteries, the breakout boards for the microcontroller and wireless system, motors, and motor drivers. This team has balanced the tradeoff of parts best for the project and least expensive parts. In Table 8.2.1 below is our total spending thus far; this is bound to change since a majority of the design will be decided once the art team joins us next semester.

<i>Item Description</i>	<i>Part Number</i>	<i>Subsystem</i>	<i>Price/Unit</i>	<i>Quantity</i>	<i>Total Price</i>
<i>Phototransistor</i>	Adafruit 2831	Motion	\$0.95	10	\$9.50
<i>Wi-Fi Breakout Board</i>	Adafruit ATWINC1500	Wi-Fi Comm	\$24.95	1	\$24.95
<i>Current Sensor</i>	ACS711KLCTR-12AB-T	Power	\$2.15	5	\$10.75
<i>Batteries</i>	TENERGY-31005-74-5200-LI-ION-PACK	Power	\$42.95	1	\$42.95
<i>QFN Breakout Board</i>	Chip Quik PA0061	Power	\$4.79	2	\$9.58
<i>Charge Controller IC</i>	TI BQ24650RVAT	Power	\$5.49	3	\$16.47
<i>SAMD21 Dev Breakout</i>	Sparkfun DEV-13672	-	\$24.95	1	\$24.95
<i>EasyDriver Stepper Motor Driver</i>	Sparkfun ROB-12779	Motion	\$14.95	2	\$29.90
<i>NEMA Stepper Motor</i>	14HS17-0504S	Motion	\$11.58	2	\$23.16
<i>Solder Flux</i>	SMD291	All	\$15.95	1	\$15.95
<i>Terminal Block 4 Pin</i>	ED2227-ND	Power	\$1.13	2	\$2.26
<i>Resistor</i>	WSLP-.02CT-ND	Power	\$0.84	3	\$2.52
<i>Terminal Block 2 Pin</i>	ED1609-ND	Power	\$0.63	2	\$1.26

<i>Diode 30V 0.2A</i>	09R9362	Power	\$0.10	5	\$0.50
<i>Inductor</i>	70K9561	Power	\$2.38	3	\$7.14
<i>MOSFET 40V</i>	01AC5005	Power	\$1.55	3	\$4.65
<i>Diode 40V 10A</i>	25R4894	Power	\$1.17	3	\$3.51
<i>MOSFET 60V</i>	25R5679	Power	\$0.16	3	\$0.48
<i>Voltage Regulator</i>	TI TPS563200DDCT	Power	\$1.66	3	\$4.98
<i>Capacitor 10uF</i>	490-1718-1-ND	Power	\$0.11	6	\$0.66
<i>Capacitor 47uF</i>	490-9960-1-ND	Power	\$0.44	6	\$2.64
<i>Capacitor 0.1uF</i>	490-6328-1-ND	Power	\$0.10	6	\$0.60
<i>Inductor 3.3uH</i>	490-6705-1-ND	Power	\$0.38	3	\$1.14
<i>Inductor 2.2uH</i>	587-1807-1-ND	Power	\$0.20	3	\$0.60
				TOTAL	\$241.10

Table 8.2.1 - Budget

Appendix A: Copyright Permission Emails

Section 2.0

i4 Business

Published by SCB Marketing 5131 Industry Dr. Suite 107 Melbourne, FL 32940 (321) 622-5986

Contact Form

Name *

Carolyn Cressman

Email *

carolynjc1027@gmail.com

Phone Number

Message *

be referenced appropriately.

<http://www.i4biz.com/uncategorized/reliability-meets-sustainability/>

Thank You,

Carolyn Cressman

Submit

Request for Image Use



Carolyn Cressman <carolynjc1027@gmail.com>
to turtlepondwines

4:30 PM (33 minutes ago)



Hello,

My name is Carolyn Cressman and I am an electrical engineering student at University of Central Florida. I am writing to ask permission to use an image from your website (see link below) in my senior design paper. Your image will be referenced appropriately.

<http://aroundlakenona.blogspot.com/2016/02/house-of-many-colors-art-glass-house.html>

Thank You,

Carolyn Cressman

Section 4.1

info@inhabitat.com

Inhabitat

Internet Brands Inc

909 N Sepulveda Blvd
El Segundo, CA 90245
(646) 820-2724

Type your comment below, and please limit your comment to 300 words.

Florida. I am writing to ask permission to use an image from your website (see link below) in my senior design paper. Your image will be referenced appropriately.

<http://inhabitat.com/dan-corsons-solar-powered-sculptures-in-portland-oregon-are-inspired-by-quirky-tropical-plants/>

<http://inhabitat.com/6-brilliant-solar-powered-art-projects-to-brighten-your-day/>

Thank You,
Carolyn Cressman

Carolyn Cressman

carolynjc1027@gmail.com

suggestion

Section 4.2

Request for Image use



Ruben Vazquez

Thu 11/10/2016 9:02 AM

To: manoj@firmcodes.com

  Reply all | 

Hello,

My name is Ruben Vazquez and I am an engineering student at the University of Central Florida. I would like to ask you for permission to use images from your website for use in a design document for my senior design coursework.

Thank you,

Ruben Vazquez

Section 4.3 – 4.6 Permission Emails:

Christiana Honsberg
and Stuart Bowden

English 

Instructions

- 1. Introduction
- 2. Properties of Sunlight
- 3. PN Junction
- 4. Solar Cell Operation
- 5. Design of Silicon Cells
- 6. Manufacturing Si Cells
- 7. Modules and Arrays
- 8. Characterization
- 9. Material Properties
- 11. Appendices

Korean Version

List of:

Search

 Like 2.8K people like this.

Contact

Your name *

Your e-mail address *

Subject *

Message *

Contact Us

Name *

Email *

Telephone

Comment *
https://www.rvworldstore.co.nz/blog/inverters/>."/>

Email: info@rvworldstore.co.nz

Tel: 03 541 0994

Postal Address:
PO Box 3068
Richmond
Nelson 7050
New Zealand

Copyright Permission



jose_jerez

Today, 1:36 PM

Daniel.zhang@suntech-power.com



Reply all

Hello,

My name is Jose Jerez and I am an engineering student at the University of Central Florida. I would like to ask for permission to use product images and datasheets from your website in a design document for my senior design coursework.

Thank you,

Jose Jerez

www.solarmust.com/contact/

Home

Products

Promotion!

Solar Installation

Expos

Contact Our Project Team

Call or submit our online form to request an estimate or for general questions.

Your Name (*)

Jose Jerez

Your Email (*)

jose_jerez@knights.ucf.edu

Country

Tel

Your Message

Hello,

I am an electrical engineering student at the University of Central Florida and would like to request permission to use a diagram found on your website for our class project documentation. The graph I would like to use is found at the bottom of this page <<http://www.solarmust.com/what-is-solar-electricity/>>.

Address

Headqu:
Xixiang, Ba
Office A
Shenzhen,
Tel: +86
E-mail:

CONTACT



H/P: +86
Tel: +86

Section 4.7 Permission Emails:

Request for Image Use



Carolyn Cressman <carolynjc1027@gmail.com>

to elktros

1:27 PM (13 minutes ago)

Hello,

My name is Carolyn Cressman and I am a student at University of Central Florida. I would like to request permission to use images found on your site for education purposes (used in senior design paper).

Thank You,
Carolyn Cressman

Request for Image Use

Inbox x



Carolyn Cressman <carolynjc1027@gmail.com>

1:29 PM (18 minutes ago) ☆



to eod ▾

Hello,

My name is Carolyn Cressman and I am a student at University of Central Florida. I would like to request permission to use images found on your site for education purposes (used in senior design paper).

Thank You,
Carolyn Cressman

Request for Image Use



Carolyn Cressman <carolynjc1027@gmail.com>

1:37 PM (1 minute ago) ☆



to webeditor ▾

Hello,

My name is Carolyn Cressman and I am a student at University of Central Florida. I would like to request permission to use images found on your site for education purposes (used in senior design paper).

Thank You,
Carolyn Cressman

Section 4.8 Permission Emails:

Request for Image Use



Carolyn Cressman <carolynjc1027@gmail.com>

1:25 PM (17 minutes ago) ☆



to mjobee ■

Hello,

My name is Carolyn Cressman and I am a student at University of Central Florida. I would like to request permission to use images found on your site for education purposes (used in senior design paper).

Thank You,
Carolyn Cressman

Request to Use Images



Carolyn Cressman <carolynjc1027@gmail.com>

1:23 PM (20 minutes ago) ☆



to nccleantech ▾

Hello,

My name is Carolyn Cressman and I am a student at University of Central Florida. I would like to request permission to use images found on your site for education purposes (used in senior design paper).

Thank You,
Carolyn Cressman

Section 4.9

Request for Image use: HyperPhysics



Ruben Vazquez

Thu 11/10/2016 9:06 AM

To: RodNave@gsu.edu



Reply all | v

Hello,

My name is Ruben Vazquez and I am an engineering student at the University of Central Florida. I would like to ask you for permission to use images from your website for use in a design document for my senior design coursework.

Thank you,

Ruben Vazquez

Request for Image use



Ruben Vazquez

Thu 11/10/2016 9:07 AM

To: contact@learnengineering.org



Reply all | v

Hello,

My name is Ruben Vazquez and I am an engineering student at the University of Central Florida. I would like to ask you for permission to use images from your website for use in a design document for my senior design coursework.

Thank you,

Ruben Vazquez

Section 5.3

Request for Image use



Ruben Vazquez

Thu 11/10/2016 9:00 AM

To: customerservice@atmel.com



Reply all | v

Hello,

My name is Ruben Vazquez and I am an engineering student at the University of Central Florida. I would like to ask you for permission to use images from your website for use in a design document for my senior design coursework.

Thank you,

Ruben Vazquez

Contact Engineering360

Note: Engineering360 does not manufacture, distribute or sell the products listed on this site and will not be able to answer specific questions about them. Please direct product-related questions to the product's supplier.

Engineering360 welcomes all feedback from our users. Is there something you'd like to see on Engineering360? Anything we can do to make your search even easier or more efficient? Let us know! Use the form below to send us your comments and suggestions.

To get your company's products or services listed in our database, please [contact sales](#).

- Comment Type: **General:** Comments or questions about Engineering360
 Sales: Get your products or services listed in our database (Remember, we do not sell the products you see on this site.)

Comments:

Name:

Company:

E-mail Address:
(Recommended, so we can reply to you.)

Request for Image use



Ruben Vazquez
Today, 12:56 PM
Sales@StepperOnline.com

Reply all |

Hello,

My name is Ruben Vazquez and I am an engineering student at the University of Central Florida. I would like to ask you for permission to use images from your website for use in a design document for my senior design coursework.

Thank you,

Ruben Vazquez

Appendix B: Work Cited

Section 2.0

<http://aroundlakenona.blogspot.com/2016/02/house-of-many-colors-art-glass-house.html>

<http://www.i4biz.com/uncategorized/reliability-meets-sustainability/>

Section 3.1

http://www.pge.com/includes/docs/pdfs/shared/solar/solareducation/inspecting_pv_systems_for_code_compliance.pdf

<http://www.mjbee.com/projects&news/nec%20art%20310.15.pdf>

<https://nccleantech.ncsu.edu/wp-content/uploads/3-Article-690-explored.pdf>

<http://ieeexplore.ieee.org/document/4518937/>

<http://www.linpin.com.cn/upload/20111202082155835583.pdf>

Section 4.1

<http://inhabitat.com/dan-corsons-solar-powered-sculptures-in-portland-oregon-are-inspired-by-quirky-tropical-plants/>

<http://inhabitat.com/6-brilliant-solar-powered-art-projects-to-brighten-your-day/>

Section 4.2

<http://www.firmcodes.com/>

Sections 4.3 – 4.6

<https://www.rvworldstore.co.nz/blog/inverters/>

<http://www.pveducation.org/pvcdrom/solar-cell-operation/>

<http://energyinformative.org/best-solar-panel-monocrystalline-polycrystalline-thin-film/>

<https://www.solar-electric.com/inverter-basics-selection.html>

<http://coder-tronics.com/c2000-solar-mppt-tutorial-pt1/>

<http://www.ti.com/lit/an/slva446/slva446.pdf>

http://batteryuniversity.com/learn/article/charging_lithium_ion_batteries

<http://www.mpoweruk.com/performance.htm>

<http://pvcdrum.pveducation.org/BATTERY/capacity.htm>

http://batteryuniversity.com/learn/archive/whats_the_best_battery

<http://gold-coast-solar-power-solutions.com.au/posts/3-phase-solar-inverter/>

Section 4.7

<http://www.electronicshub.org/light-sensors/>

<http://www.johnloomis.org/ece445/topics/egginc/tp4.html>

<https://www.britannica.com/topic/sunlight-solar-radiation>

<https://en.wikipedia.org/wiki/Sunlight>

<http://www.ti.com/product/opt3001/samplebuy>

<http://www.ti.com/product/opt3001>

<https://www.adafruit.com/product/2831>

http://www.mouser.com/ProductDetail/Fairchild-Semiconductor/QSE113E3R0/?qs=DBUMZ2Yty90ulfgRRAwmXg%3D%3D&qclid=CjwK-EAjw-uDABRDPz4-0tp6T6IMSJADNoyPbgj731ftxSBU7P2H8suEqjP1HKyLSeKzWPWGh97D4uxoCoTLw_wcB

Section 4.8

<http://www.digikey.com/en/articles/techzone/2012/sep/the-basics-of-current-sensors>

<http://sensing.honeywell.com/honeywell-sensing-current-sensors-line-guide-005895-1-en.pdf>

<https://www.arrow.com/en/products/acs711eexlt-15ab-t/allegro-microsystems>

<https://www.arrow.com/en/products/acs711klctr-12ab-t/allegro-microsystems>

<https://www.arrow.com/en/products/acs711elctr-25ab-t/allegro-microsystems>

Section 4.9

<http://hyperphysics.phy-astr.gsu.edu/>

<http://www.learnengineering.org/>

<http://howtomechatronics.com/how-it-works/electrical-engineering/stepper-motor/>

Section 5.1

http://www.powerstream.com/Wire_Size.htm

Section 5.2

<http://www.ti.com/lit/an/slyt499/slyt499.pdf>

<https://soveriegntrysolar.wordpress.com/2012/07/13/micro-inverters-advantages-and-disadvantages-in-solar-photovoltaic-systems-2/>

Section 5.3

<http://www.atmel.com/>

http://www.atmel.com/Images/Atmel-42181-SAM-D21_Datasheet.pdf

<http://learn.parallax.com>

<https://learn.adafruit.com>

<http://www.globalspec.com/>

Section 4.10 & 5.4

http://www.st.com/content/ccc/resource/sales_and_marketing/promotional_material/brochure/d7/74/dc/eb/b4/f5/40/d5/brwireless_web.pdf/files/brwireless_web.pdf/jcr:content/translations/en.brwireless_web.pdf

<https://en.wikipedia.org/wiki/Wi-Fi>

<https://en.wikipedia.org/wiki/Bluetooth>

https://en.wikipedia.org/wiki/Bluetooth_low_energy

<http://www.instructables.com/id/PART-1-Send-Arduino-data-to-the-Web-PHP-MySQL-D3js/>

<https://www.arduino.cc/en/Tutorial/WebClient>

<http://circuitdigest.com/microcontroller-projects/sending-arduino-data-to-webpage>

http://batteryuniversity.com/learn/article/how_to_measure_state_of_charge

Section 6.2

http://www.pcbway.com/?adwgc=676&campaignid=172480651&adgroupid=8787904531&feeditemid=&targetid=kwd-140190344&loc_physical_ms=9060005&matchtype=p&network=g&device=c&devicemodel=&creative=151044558706&keyword=pcb%20manufacturers&placement=&target=&adposition=1t3&gclid=CNqbqNrM0NACFREHhgodAOoPzA

<https://www.sunstone.com/about-sunstone/our-story-history>

http://www.4pcb.com/about_us/

<https://www.pcbnet.com/Quotes/introductory-offers>