

Smart Grill

Senior Design 2 Project Documentation

Group 39

Thierry Alerte
Jonathon Graff
Jeff Mueller
Jonathan Schooley

Table of Contents

1) Executive Summary.....	1
2) Project Definition.....	2
2.1) Motivation.....	2
2.2) Goals and Objectives.....	2
2.3) Specifications.....	3
2.4) Design Constraints.....	3
3) Research.....	4
3.1) Similar Grills on the Market.....	4
3.2) Different Types of Grills.....	5
3.2.1) Charcoal.....	6
3.2.2) Natural Gas.....	7
3.2.3) Electric.....	8
3.3) Temperature Sensors.....	9
3.3.1)Thermostat.....	11
3.3.2) Thermistor.....	14
3.3.3) Resistive Temperature Detector (RTD).....	19
3.3.4) Thermocouple.....	25
3.4) Electric Burners.....	27
3.5) Power Supplies.....	28
3.3.2) Infinite heat switch.....	29
3.3.2) Batteries.....	31
3.3.3) Voltage Regulators.....	36
3.3.4) Power Relays.....	38
3.3.4) Transformers.....	43
3.3.4) Rectifiers.....	44
3.6) Grill Housings.....	47
3.7)LCD Touchscreens	51
3.8) Wifi/Bluetooth Communication.....	53
3.9) Android Application Development.....	54
3.10) Database.....	55
3.11)Microcontroller.....	57
4) Design Plan.....	60
4.1) Temperature Sensing.....	62
4.1.1) Ambient Temperature Sensor.....	63
4.1.2) Food Temperature Sensor.....	65
4.1.3) Burner Temperature Sensor.....	66
4.1.4) Temperature Sensor Placement.....	66
4.2) Electric Burners.....	67
4.2.1) Burner Control.....	67
4.2.2) Feedback from Temperature Sensors.....	68
4.3) Power Supplies.....	69
4.3.1) Low Voltage Power.....	69

4.3.1.1) Microcontroller.....	69
4.3.1.2) LCD Touch Screen.....	70
4.3.1.3) Wifi/Bluetooth Module.....	71
4.3.2) High Voltage Power.....	71
4.3.2.1) Electric Burners.....	72
4.3.2.2) Regulating Burner Power.....	73
4.4)LCD Touch Screen Interface.....	74
5) Power Management	75
5.1) Batteries.....	76
5.1.1) Fuel Gauges.....	76
5.1.2) Battery Chargers.....	79
5.2) Transformers.....	81
5.3.1) Step down.....	81
5.3.1) Step up.....	81
5.3) Regulators.....	82
5.3.1) Linear Regulators.....	83
5.3.1) Switching Regulators.....	85
5.4) Power relays.....	87
5.5) Rectifiers.....	88
6) Final Production.....	92
6.1) PCB/Circuit Design.....	93
6.1.1) Design software.....	94
6.1.2) Fabrication.....	95
6.2) Mobile Application Design.....	95
6.2.1) User Interface, Design, and User Experience.....	96
6.2.2) Features.....	97
6.2.2.1)Assembly.....	97
6.2.2.2) Getting Started.....	98
6.2.2.3) Power ON.....	99
6.2.2.4) Navigation.....	99
6.2.2.5) Operation Modes.....	99
6.2.2.6) Save temperature/time settings.....	99
6.2.2.7) Power OFF.....	99
6.2.2.8) User Profiles.....	100
6.3) Microcontroller Software Design.....	100
6.3.1) Language.....	101
6.3.2) Data Collection and Transmission.....	102
6.4) Class Diagrams.....	105
7) Project Prototype	106
7.1)Hardware Specific Testing.....	108
7.1.1) Overview.....	108
7.1.2) Circuit Design.....	109
7.1.3)Load Testing.....	110
7.1.4) Power System.....	111
7.1.5) Battery System.....	112

7.1.6) Integration: Battery, Power System.....	114
7.1.7) Motor.....	115
7.1.7.1) ESC.....	115
7.1.8) Microcontroller.....	116
7.2) Software Specific Testing.....	117
7.2.1) TestFramework.....	117
7.2.2) Version Control.....	118
7.2.3) Updated testing	
7.3) Food Product Testing.....	119
7.3.1) Specific Food Testing.....	119
8) Related Standards	119
8.1) Standards.....	119
8.2) Discussion on Realistic Design Constraints.....	119
8.3) Economic and Time Constraints.....	119
8.4) Social and Political Constraints.....	119
8.5) Ethical, Health, and Safety Constraints.....	120
8.6) Manufacturability and Sustainability Constraints.....	120
9) Administrative Content.....	121
9.1) Milestone.....	121
9.1.1) August/September.....	121
9.1.2) October/November.....	121
9.1.3) December/January.....	121
9.1.4) February/March.....	122
9.1.5) April/May.....	122
9.2) Budget.....	122
9.2.1) Parts.....	123
9.2.2) Bill of Materials.....	123
9.3) Division of Labor.....	123
10) Appendices.....	124
10.1) Abbreviations/Acronyms.....	124
10.2) Datasheets.....	124
10.3) Permissions To Use Figures.....	124
10.4) References.....	125
10.5) User Manual.....	125
10.6) Microcontroller code.....	125
10.7) Project Photos.....	125

1.0 Executive Summary

Multitasking is very important to a productive lifestyle. Imagine cooking dinner on your electric grill without actually having to stand there and watch over the food. The Smart Grill changes the way you cook your meal by giving you more time to do other things while your meal is cooking. With our product, all you have to do is select what you are trying to cook and the grill will notify you when your assistance is needed, it will take care of the rest.

This project involves using an electric grill with an LCD touch screen. If you want to cook hotdogs, for example, the user could turn the grill on and select hotdog from the touch screen display. The grill will then begin to warm up to the necessary temperature. Once the grill has warmed up, you will be notified on the grill touch screen and through an application for your mobile device. Although using the mobile application isn't absolutely necessary for this product to function, it will help keep you informed of when it's time to grab your meal.

Now that the grill is warmed up, a temperature sensor will need to be inserted into the food that you're cooking. Once your item is on the grill, simply select begin cooking on the screen. From here, there will be three temperature sensors: a sensor for the temperature of the food, a sensor for the grill burner, and a sensor for the air in the grill space. These temperatures will be displayed on the LCD touch screen and on the mobile application. A timer will give you the estimated time until your food needs attention, such as being flipped and also the time remaining until the food is completely cooked and ready to eat.

All of this is managed with a microcontroller which will read temperature data coming from the sensors, and communicate with the electric burners so they will be able to heat up or turn off and maintain the correct temperature within the grill. The microcontroller will also transmit this information to the mobile application so you don't have to stand by your grill the entire time monitoring what is going on. Even though the grill will be able to take care of most of the cooking, it is important not to leave the grill unattended for extended periods of time to reduce the risk of fire.

Ideally, this product will be able to cook a wide variety of products with minimal assistance and monitoring from the user. The use of an electric grill makes this method of cooking more versatile as one can prepare their meal indoor or outdoors and without the mess of using a traditional charcoal grill. The grill should be able to be plugged into a 120V household electrical outlet which will power the grill and all of the onboard components such as the microcontroller and the touch screen. There are similar products to this on the market however, our approach should make this product more affordable. The Smart Grill will attempt to revolutionize the way that people make their meals.

2 Project Definition

2.1 Motivation

The motivation behind this project was that all of our group members have somewhat of an interest in cooking on a grill. Unfortunately, grilling can be a time consuming process and it can be very easy to overcook your food if it is not being closely monitored. We wanted to seek out a better way to grill, without the need to constantly be standing over the grill until your food is ready. Since almost everything can be done through a smartphone nowadays, we thought it would be a great idea to grill food using a smartphone as well.

Ever since the invention of fire, food has been cooked and prepared hot and juicy. Since then the entire world has become dependent on searing their meat and vegetables on a grill. If it wasn't for our technology driven society, we would not have all the different options to cook our food. Electricity, propane and wood and coal drives the cooking industry just as electricity drives our daily lives. Since everyone's taste buds are subjective The only way to tailor to everyone's taste buds is to consider all flavor changing applications that encompass the grill.

It is the primary goal of this project to ensure that grillers have the convenience and option to grill how they choose which remains unaffected by power receptacle convenience, grill proximity, cooking know-how, fuel source and flavor not to mention electric grills offer convenience, safety, and less pollution making this a great option. With an investment for the Smart Grill, a grill can easily make their home into On-The-Go, set it and forget it flexible fuel, Indoor/Outdoor rotisserie Smart Grill. If you can not afford to buy our grill, then this technical paper serves as guidelines for the average joe to recreate this project in his or her own way for a cost effective solution. It is up to the griller to decide what is in their budget and how much technology and functionality that their grill rig utilizes. One of the best features of our project is it gives the griller the freedom to choose the right part that will fit with their grilling needs.

This idea could be extended to all types of cooking applications, such as controlling your microwave or oven, however these are already pretty easy to use. A grill takes considerably more time and effort to use properly so our project aims to bring convenience back to grilling. With this product, your next cookout with friends and family can leave you spending more time with your loved ones, than with your grill.

2.2 Goals and Objectives

The goal of this project is to create a fully functional grill that can be controlled via a smartphone application. We would like this process to require minimum effort from the user. The grill should be able to communicate to the smartphone the temperature of the burners, meat, and the air inside of the grill housing. The time remaining until the food is completely cooked will also be displayed on the smartphone application. Most food items will require being flipped over at some point during the cooking process to ensure that it is evenly cooked on both sides. For these situations, the smartphone will display the time remaining until the user needs to return to the grill to flip their food.

The objectives of this product are to have a smartphone application and a LCD touchscreen to interact with the grill. The grill should be able to completely cook the food on its own with minimal assistance from the user. The microcontroller will constantly monitor temperatures from the three individual temperature probes to control the electric burner intensity. It should be programmed so that it will not exceed certain temperatures and burn the food being cooked. The grill should be able to cook multiple types of food and the desired option will be selected prior to cooking. From here, preset cooking temperatures will be used as a guide to ensure the food is being completely cooked and is ready to eat. The grill could also have a feature so the user can manually set cooking temperatures and cooking times if they do not wish to choose a food item from the list of options. This will also allow flexibility to cook at temperatures not preprogrammed.

In our project we will be designing a system used to deliver power/signals to our subsystems either via the On-board user interface or the Mobile Phone app. Our subsystems include: electric burners, rotisserie, MCU. The project will consist of three key components, a power strip similar to the one you see home appliances usually plug into, a device for measuring power consumption, a touch screen monitor as well as Mobile App used for the user interface. The power strip will contain voltage and current sensing circuits along with a microcontroller to calculate power consumption and quality. This processed information will then be sent wirelessly via RF communication back to an embedded touch screen microcontroller for display to the user. The main intent is for the power to be managed at one location. At the onset of a power failure a failsafe gauging battery should also be implemented which should also be considered in this power system. The touch screen monitor will include a microcontroller and wireless RF communications for receiving and transmitting data.

In order for the user to interact with the system a touchscreen and mobile phone app will be used. These will have different inputs the user can manually enter and different outputs that monitor the grill temperature, food temperature, battery power, motor speed, timer, etc. The first input will allow the user to manually

preset all the time intervals for the future cookout. The second input is to set the motor speed and if needed set the time intervals for the different speeds. The third input would be for the user to manually change the temperature of the burners or coal (in which a fan or motor used to open and close the lid should then be implemented). These 3 basic inputs have the option of being set on the unit itself or remotely from your phone app. More inputs and functionality will be fitted into the project as need be.

During cookout times the user initiates the grill either at the grill or from the convenience of a wireless device while watching the game. Upon turning the grill on the interface prompts the user to select the food being grilled. There will be preset settings which will depend on the type of food, however if the user wishes to either alter the preset or make one custom from scratch that option is also available. Time intervals, temperatures, motor speeds, smoking enclosure amount and even period report cards can be generated all from the sensors in our grill. These features will aid the average griller on flavorful cuisine in an relaxing stress free environment enabling you to spend time doing whatever else needs to be done to get dinner on the table for you family. When normal utility power is lost and you have no more coal or lighter fluid there is still the option of using the on board battery to supply power to the system. The touchscreen will control everything that the mobile app will be able to control as well. The whole point of our integrating a mobile app with our system is to enable the griller to multitask unlike before while using Smart Grill.

Many people enjoy grilling at least once a week, during that time they have to neglect something else to man the grill. This is why we believe something like this could be so useful if it were available. Not only will this design help grillers grill more flavorful food in a relaxing setting, but it can also help them free up an extra hand to help someone else in the kitchen or hold the remote control.

2.3 Specifications

The design will utilize a kill power safety switch to transfer power to a secondary power supply in case of a safety emergency or a wall outlet is not available. The safety switch is a third party device so It only needs to be tested for functionality. For this project the use of a battery to provide secondary power in case of a no power condition is intended. After power has been transferred the subsystems should be able to be just as effective and efficient as the power from the outlet will be.

Since each subsystem will need to be able to read and write data we decided to make a central processor make the bulk of the computations and direct the majority of the signal flow. One thing that will be counted for when testing and making sure components are all compatible is if too much power is being

absorbed with respect to the amount of power delivered. This idea should be an important concept when programming the different safety precautions. An interrupt signal can be sent to the microcontroller that is in control of any part of Smart Grill. The microcontroller must then stop the use of the subsystem immediately.

Each microcontroller will measure a specific measurement of either time, temperature, speed or a combination of the 3. The accuracy of these measurements should be precise enough to accept a certain amount of percentage error dependent on how much percentage error will produce a unnoticeable effect on the flavor of Smart Grill food. We will set our initial goal to reach a precision of 1% of the actual value of the parameter in real time. Then in the final report we will look more toward diminishing or strengthening this error to be taste bud acceptable. The main unit will receive data, reading information from all the other microcontrollers which has a maximum refresh rate equal to the clock rate of either the main MCU or the subsystems MCU. The main unit will provide absolute instructions to all other microcontrollers. It must have the ability to stop and resume operation of any subsystem in Smart Grill. These parameters will be set by the user through an LCD or mobile app interface. User parameters will be sorted by time based on user input. (Similar to a powerpoint effects timeline or something that allows you to do sequential editing with respect to time). The main processor will go through each of the user's' command from top to bottom or first to last.

The concept behind the entire project is as follows. During normal grilling operating conditions, the griller may use the LCD touch screen monitor to observe time checkmarks and timer statistics, rate of motor, battery/unit power consumption, and temperature. What is so cool about this interface is that since everything is in real time, this change in real time. For example, when you change the RPM on the rotisserie motor to go slower then eventually, in time, the griller should see the temperature respectively fluctuate to a steady state level and since the temperature has changed then the time checkmarks will also change. The user would also have the ability to remotely control individual or even group settings in the MCU subsystems to have a successful grill out. The design will utilize a kill power safety switch to transfer power to a secondary power supply in case of a safety emergency or a wall outlet is not available. The safety switch is a third party device so It only needs to be tested for functionality. For this project the use of a battery to provide secondary power in case of a no power condition is intended. After power has been transferred the subsystems should be able to be just as effective and efficient as the power from the outlet will be.

The power specifications and requirements for some of the absolutely necessary power components are shown below in Table 2.3.

Table 2.3

	Battery	Power Rectifier	Regulator	Transformer	Power Relay
Voltage	12	100	5/12	120/24	>200
Amperage	35 Ah	2	2	2	>20
Type	rechargeable lithium ion	Any	low power	Any	triac-fet
Weight	<25 lbs	Any	Any	Any	Any
Length	<10"	Any	Any	Any	Any
Width	<10"	Any	Any	Any	Any
Height	<10"	Any	Any	Any	Any

Table 2.3

The Main MCU will consist of a controller that receives information from all the subsystems and displays this information on the user controlled LCD display and then also wirelessly transmits this data to the mobile app. This main MCU should also be able to send and receive information from the subsystem MCUs as well. If the LCD/mobile app relays information to shut down a specific function or the entire unit then an interrupt signal must be sent to relay that information.

The specifications for this unit are as follows:

- Enter sleep/safety mode after time length of inactivity.
- Grill for 1 hr with maximum heat (with battery in use)
- When the grill is off, the batteries automatically recharge.
- elements achieve surface temperatures of approximately 1,100F
- Ten minutes after plugging it in, hitting the main power switch, and turning the burner controls to high
- Receive data from 3 different sensors every 2 seconds
- Communicate this data to the LCD (main MCU) 3 seconds

- The LCD and the main control station are in constant communication.
- Must have an ADC that is 10 bits wide for 1024 steps of resolution
- Receive and transmit information with an accuracy of 1 decimal place with the local microcontroller

While a function of Smart Grill is not being used it should enter a sleep mode to preserve the battery life of that specific unit (if the battery is being used instead of the power outlet). The microcontroller will remain in sleep mode as long as there is no signal telling it to turn on. Once the microcontroller receives the signal to turn on it will return to normal operation.

2.4 Design Constraints

The intentions of our project are to design indoor/outdoor Smart Grill that is ideal for family cookouts. This will be beneficial to the family due to the grill master having now the option to man the grill from a remote location. And during times when fuel sources and grill real-estate are scarce there are alternative ways to cook with Smart Grill. We added the coal burning functionality as well as we made use of rotisseries above the grill surface for a greater food grilling area. We are going to design a global power system which will deliver power to all are subsystems. Everything that the griller needs to know about time, speed, temperature, and battery/unit power consumption would then be sent back to a controller wirelessly that would then be further processed. The controller would then communicate to a LCD touch screen monitor as well as mobile application which would give the user access to the system. The user needs access to the system to add, change, or remove temperature, speed and time in a extremely flexible way. The user interface will also contain a kill stitch to allow the user to remotely turn on and off appliance through the LCD touch screen monitor in the case of a grilling failure.

The concept behind the entire project is as follows. During normal grilling operating conditions, the griller may use the LCD touch screen monitor to observe time checkmarks and timer statistics, rate of motor, battery/unit power consumption, and temperature. What is so cool about this interface is that since everything is in real time, this change in real time. For example, when you change the RPM on the rotisserie motor to go slower then eventually, in time, the griller should see the temperature respectively fluctuate to a steady state level and since the temperature has changed then the time checkmarks will also change. The user would also have the ability to remotely control individual or even group settings in the MCU subsystems to have a successful grill out.

A commercial gas or charcoal grill for home use is typically unable to all the functionality that Smart Grill offers, not to mention it can only do either gas or charcoal. Thus, during an emergency grilling situation (for example, the

neighbors grill died while cooking and they need a grill for their Bday party) the user would have the option of using the Smart Grill with no power cord just battery. Just in case that they started out cooking with charcoal, Smart Grill can continue their way of cooking so the flavor of the food is not damaged. The user would also have the option to continue grilling all the neighbor's food but now the user is able to socialize and have a beer with everyone.

Our project will use one central MCU with smaller subsystems and one central power system deliver power and command signals to control all the subsystems. Smart Grill will collect all of its data for the grill session at the beginning and throughout the session and will wirelessly send this information back to the main controller for processing. During the initial transfer between data into the MCU for processing, the controller will automatically find a steady state average value for the system as a whole by cleverly interconnecting subsystems with proper formulas and programming so that each variable connects with the next so a domino effect is implemented. From this point the user could then use the LCD touch screen monitor to decide what they can do to make the food taste better with the click of a button. The only downside to this is that whatever is not on the rotisserie will eventually have to be flipped manually. However, with clever programming Smart Grill should be able to tell the user exactly when to flip the food to get the desired flavor. The Smart Grill will look at how far the user has strayed from the general guidelines from how a piece of food is supposed to be cooked in order to achieve this desired effects, then compensate via other subsystems to achieve an overall desired effect. This feature allows the griller to use any cooking technique to make an accurate description of what was in your mind before beginning to grill.

The intent of our project is to design a indoor/outdoor Smart Grill system. This system will be versatile in that it will be beneficial to the griller during no power conditions, different fuel source scenarios, rotisserie grilling scenarios, as well as multitasking scenarios. Our goal was to not let one variable limit the griller in any critical way. Often, the average griller is unaware of the many details of the effects from higher rotisserie speed and higher temperature. Questions like, "Can I rise the heat super high, super fast in order to get a nice sear?", "How long will the battery last on high medium and low power consumption settings?", or "What is the best speed to rotisserie at, and how fast can the motor go before the food flies off the rotisserie?" These questions and many more will be questioned and answered throughout this project, while although simplified, still giving the end-user as much control as possible.

The main design of our project begins with a questionnaire that will ask the user everything that needs to be known in order to start grilling promptly. The user's initial input of variable that will determine the day's grill session, at which point the the user can even set the grill to turn on before getting home, that way the grill is hot and time has been saved. Also the progress of the session is sent to

the interface in which the user at this time can change any aspect of any variable. The microprocessor would be constantly monitoring the signals coming from the sensors, clock and memory, The signals will be gathered in the MCU and then the control signals will be delivered to the subsystems respectively. Our design will be a stand alone versatile Smart Grill that resembles a regular everyday grill. It will have a power cord as well as an internal battery. The battery will consist of a gauging circuit to constantly taking measurements like power consumption so the users grilling session is not cut short on account of low power. The LCD touch screen monitor will also allow the user to manually control anything that the mobile app is able to remotely control. This information will then be processed at the main LCD microcontroller and then transmitted wirelessly to the subsystem MCUs.

The wireless communications in our system will be done using a single protocol, which is yet to be determined. Shown below in Figure 1, each wireless device will be a transceiver (i.e. has the ability to transmit and receive data); they will not communicate with each other, but only to and from the central microprocessor (in the LCD). The wireless transceivers will be used over a short range in our prototype, this aspect will allow for lower power usage, as well as lower costs for the transceivers.

The LCD will contain the main “hub” microprocessor which will collect data from the power strip modules and is where the bulk of the calculations and decisions will be made. This LCD display among the mobile app will be the interface between the user and the software which will read/write time, speed and temperature. During normal operating conditions, the user will be able to control everything just as the grill was not operating under normal conditions. There will also be a section on the LCD which will provide the user with pertinent data about their grill session. In this section, an emphasis will be placed on “useful” data; that is, we don’t wish to give overwhelming amounts of graphs and numbers which may require knowledge of math to interpret and understand. The LCD will show (as well as give the ability to change) information in as simple a form as possible, while still providing important, useful data including:

- Instantaneous battery voltage and runtime
- Individual rotisserie stick temp. / ambient temp.
- rotisserie speed
- Individual timelines/check marks for each food item
- Safety alarms

An emphasis will be placed on showing as many picture icons as possible, so the user can more easily relate to the information on the screen. Abstract figures, graphs, and even most other data will be the user as a summary of the grill session so that next time the griller can hone in on being a better griller.

The design constraints of the power system for Smart Grill that our group had to realize and will be discussed further in power management section 5 are the following:

- User Safety
- Minimizing Expense
- Time constraints
- Resource constraints
- Power system ambient air temperature
- Wall outlets and battery power supply
- Electrical burners
- Power for MCU (which will power subsystems)

3 Research

3.1 Similar Grills on the Market

There are many other grills on the market with similar technology as ours. Many of these products that are available are very expensive and would not be financially practical for the everyday consumer. Lynx Professional Grills offers a freestanding smart grill for around \$9,500, model #SMART42F. There are several other models available for a couple thousand dollars cheaper, however this model will be used as a reference as it is the largest and has the most comprehensive features available. This grill comes with three separate infrared burners that can function independently of each other. This allows for a lot more flexibility as you can have different elements of your meal cooking simultaneously on different burners all while being monitored by the grill. A rotisserie feature is also available with multi speed selections available to choose from within the mobile application. The grill also has a built in microphone and speaker for easy communication between the user and the grill. With the microphone the user can give voice commands to the grill and is able to get audible feedback from the speaker. This Smart Grill has an application that can be accessed through a smartphone or tablet and has a lot of versatility.

The #SMART24F connects to the internet via WiFi and the iOS or Android device needs to be connected to the same internet router for communication between the two devices. This grill does not connect to the mobile application via bluetooth which could assist the user with being able to have more mobility away from the grill as range with bluetooth is often less than with a WiFi connection. When it comes to cooking, there are multiple ways that it can be done with this grill. Like with our smart grill, you can select from a list of recipes through the mobile application. While our smart grill will have a couple of recipes to choose from, Lynx offers over two hundred recipes through their mobile application. Different users using the application can even rate these recipes to help you

decide what would be worth making for dinner. If a recipe isn't listed, users can even upload their very own recipes with cooking guidelines that can be adapted to be prepared automatically with the grill.

This smart grill also allows for the user to use the grill without the mobile application and just to cook on it normally like any other grill. If the user wants to use the mobile application, while having full control of the cooking process, cooking time and temperature can be manually set within the mobile application. This can process be extended to control the different burners and cooking time as well, just like with making a recipe that is already uploaded on the mobile application. As with our grill, this grill will communicate to the mobile device when the grill needs the user's attention such as flipping over the food being cooked or taking it off the grill as it is finished cooking. (Lynx Grills, Inc., 2015)

Another product that is available on the market doesn't actually have much to do with the grill itself but offers a simpler solution to smart grilling without all of the additional features a smart grill would have. The iGrill2 is a product that utilizes smart temperature sensor. This is designed to be placed on or near a normal grill without the additional smart technology. A temperature probe can then be placed into whatever meat you are grilling and the real time temperature will be displayed on the device. Since this is connected to your smartphone via bluetooth, the real time temperature will also be visible there as well. With this device, up to four temperature probes can be plugged in at one time and all four probes can be monitored individually.

The iGrill2 doesn't have any effect on burner temperature or anything at all to do with the grill, so all of that needs to be set manually from the actual grill. It essentially allows you to remotely monitor the temperature from up to four different food items being cooked simultaneously. This product needs a little more attention from the user as it has nothing to do with cooking times, as it only monitors temperature. On the smartphone application you can label what each of the probes is monitoring and also set the desired cooking temperature you are trying to reach. Once the food product has hit the desired temperature, an alert is sent to the user's smartphone so they know that it is ready to be taken off the grill. This product also offers a recipe database, however it is for informational purposes only and your grill will not be able to cook the recipe on its own like the #SMART24F is able to do. Also, seeing how the temperature monitoring device connects to the smartphone via BlueTooth instead of WiFi, there is probably a more limited range in mobility for the user.

The advantage of the iGrill2 temperature sensors over the #SMART24F smart grill is that the price is significantly cheaper. The iGrill2 starter kit comes with the temperature sensing housing with two temperature probes for around \$100. To fully utilize the device with all four probes, two additional probes can be purchased for \$25 each. For around, \$150 one can have the complete iGrill2 for about 1.5% of the price of the #SMART24F, making it a lot more affordable for

the everyday consumer. For those looking for something even cheaper or not needing any more than one temperature probe at a time, the same company offers the iGrill mini which offers the ability to monitor one temperature probe at a time and still communicates the temperature data to a smartphone. If necessary, the smartphone can even track the temperatures on multiple temperature sensing devices for people cooking more than four things at once. (iDevices, Inc., 2015)

With our product, we would like to make a hybrid of sorts of the #SMART24F and the iGrill2. It will have some of the capabilities from both the iGrill2 and the smart grill. Since we will not have a commercial product and we are only creating a prototype, an online recipe database will not be utilized for the grill we are creating. However, the burner temperature will be implemented in the design.

3.2 Different Types of Grills

3.2.1 Charcoal Grill

The Charcoal grill has 3 main components: 1) Cooking Surface 2) Charcoal container and 3) The Grill Support. There are many different variations of these main components, but these three never change. For our project we will be incorporating charcoal as well as electric.

The majority of charcoal grills themselves fit into 3 main categories: Ceramic Grills, Barrel Grills and Kettle Grills. Open Grills are electric grills that have a heating element on one side for grilling one side at a time. The person grilling would have to flip the food to allow the food to be cooked evenly. For our project we will be modifying an existing electric grill with a rotisserie option. For the main part of the grill we have decided to purchase the Meco 1500-Watt Deluxe Electric Grill with Rotisserie.

The Ceramic Grill is the most versatile and effective type of charcoal grill. This is because the ceramic chamber retains heat and moisture more efficiently than any other charcoal grill option. Ceramic grills can be used for grilling, smoking and baking. Certain foods like pizza can be baked at 500 degrees F. This type of grill can produce temperatures up to 750 degrees F. There is usually a top and bottom air vent used to control the temperature. A ceramic grill is shown in Figure 3.2.1a



Figure 3.2.1a

Barrel Grills are shaped like a barrel sliced in half lengthwise. The top half forms the lid and the bottom half forms the charcoal holding chamber. A vent, cut into the top and bottom halves of the barrel, controls airflow and temperature. There is usually a chimney to control smoke from escaping that is attached to the top lid. With the lid closed heat is controlled with the vents. Barrel Grills come in many sizes and shapes with various side table attachments. Barrel grills can be used for grilling, smoking and baking. Certain foods like pizza can be baked at 500 degrees F. This type of grill can produce temperatures up to 750 degrees F. There is usually a top and bottom air vent used to control the temperature. An example of a barrel grill is shown in figure 3.2.1b below.



Figure 3.2.1b

The Kettle Grill is composed of a lid, cooking grid, charcoal grid, lower chamber, venting system and legs. Some models have an ash catcher pan and wheels. The lower chamber that holds the charcoal is shaped like a kettle. The advantage that the Kettle grill has over other grill types is its shape. It is designed to distribute heat evenly. When the grill hood is down, flare ups from dripping grease is prevented by controlling the oxygen intake which allows heat to circulate around the food as it cooks. This also holds in the favor enhancing smoke which is produced by the dripping grease and smoldering charcoals. An example of a Kettle grill shown in figure 3.2.1c



Figure 3.2.1c

Charcoal itself is actually wood and not a rock or even a coal. It is created by heating specific woods in a sealed box of steel or clay to very high temperatures in the absence of oxygen. The temperature is heated up to about 1000°F (538°C). There are 2 main types of charcoal used today: Lump Charcoal and Charcoal Briquette

Lump Charcoal is Charcoal in its natural form. It is easy to light, produces less ash than standard briquettes and gives a natural smoke flavor when used in cooking. This type of Charcoal is very responsive to oxygen making it easier to control temperatures. It also contains no chemicals or fillers to help light up or burn longer. The advantages Lump Charcoal has to other options is it's easier to light, burns hotter and is a cleaner option than other standard Charcoal briquettes. Charcoal Briquettes are manufactured wood by-products compressed with additives that enable them to light easily and burn consistently. The additives can give off a chemical smell when lit. The smell can be avoided if the briquettes are allowed to burn until covering in white ash before cooking food. They do provide a more stable burn and maintain a steady temperature for a longer period of time with less hand holding than lump charcoal.

3.2.2 Natural Gas Grill

The Natural Gas grill is more complex than a Charcoal grill. There are many components but the most common components include: 1) Gas source i.e natural gas, 2) Hoses 3) Valve regulators 4) Burners 5) Starter 6) Cooking surface 7) Grill Body 8) Grill hood. These are shown in figure 3.2.2a



Figure 3.2.2a

The Grill body houses all of the other components except the hood. The hood itself covers the cooking surface and serves to trap the heated air inside and increases the temperature inside of the grill. The gas source is connected to the valve regulators via the main hose. These regulators are controlled by knobs that a person turns to determine the amount of gas that is sent through each valve to the burner. Each burner has a regulator and has a series of tiny holes along the length of the burner where the gas exits.

3.2.3 Electric Grill

The Electric Grill is the most common alternative to charcoal and gas grills. They are usually small, indoor countertop or table top grills, but there are also larger

ones for outdoor and patio uses. Electric Grills obviously use electricity as their heat source. They are plugged into an electrical outlet for power source. This type of grill has a heating element that is either embedded within the cooking surface or directly below it. Many electric grills have a drip pan underneath the elements to catch any juices that run off the meat and other items being grilled. The pans are usually detachable. There are two types of Electric grills: Clamshell (Folding) contact and Open grill with a single side heat element.

Clamshell (Folding) Contact grills have heating elements for grilling on the top and the bottom of the meat simultaneously. This type of Electric grill could be equated to “press”. They require less attention from the person grilling. Examples include a panini press and the George Foreman Grill. Open Grills are electric grills that have a heating element on one side for grilling one side at a time. The person grilling would have to flip the food to allow the food to be cooked evenly.

For our project we will be modifying an existing electric grill with a rotisserie option. For the main part of the grill we have decided to purchase the Meco 1500-Watt Deluxe Electric Grill with Rotisserie. This pre modified grill is shown in Figure 3.2.3a and specifications in table 3.2.3a.



Figure 3.2.3a

Dimensions

Length x Width x Height	43.0 x 21.0 x 41.25	Inches
Weight	40	pounds

Table 3.2.3a

3.3 Temperature Sensors

3.3.1 Thermostat

A thermostat is a type of temperature sensor that can be used to perform a switching action. Two different metals are bonded together to form a bimetallic strip which will bend when subjected to temperature changes. In most home temperature thermostats, a coiled thermostat, referred to as a “creeper” bimetallic sensor can be found which will become more tightly wound or more loosely wound based on the ambient air temperature. This will give a mechanical reading on a dial with an arrow as opposed to a digital thermostat. There are also snap-action thermostats consisting of a straight bimetallic bridge and an electrical contact. When the temperature changes, the bridge will either bend up or down causing it to move away from the contact and creating an open circuit condition. This use could be beneficial to use in a hot water heater so when the water reaches the desired temperature, the bridge would bend and lift off the contact causing the heating to stop. Both the creeper and snap-action temperature sensors work because the bimetallic strip consists of two different metals that will react differently to changes in heat. Since they are bonded together, if one expands more than the other, it will create the bending action allowing you to cut off an electrical connection or display a different value on a mechanical dial (www.electronics-tutorials.ws, 2015). Snap-action sensors seem to be the most useful when you have a desired temperature that you want as the cut off point for device, however it doesn't seem to be very versatile as far as the cut off temperature goes. For example, if you always wanted your grill to always heat to 400°F and then stay there, a temperature sensor like this could be connected to the burner current and would be cut off every time it reached the desired temperature. This would probably be ideal in something like a waffle iron but not necessarily a smart grill. The creeper sensors would be useful in a grill setting where you wanted a mechanical dial to display the temperature of the grill or meat. In fact, there are many food temperature sensors that work this way commercially available, however they wouldn't be very practical for a smart grill as the temperature reading needs to be converted into a digital form, not as mechanical reading from a dial.

3.3.2 Thermistor

A thermistor is a resistor that changes its resistance value based on the temperature that it is subjected to. This can be very useful in circuits where you need to turn a change in temperature to a change in voltage. A thermistor will most likely be the type of temperature sensor that we will use for this project due to its large range of sensing ability and versatility. The thermistor will need to be

calibrated to determine what resistance value you get at different temperatures. This can then be documented and implemented in the microcontroller code to reflect the actual temperature value based on the resistance value of the thermistor. To do this, a simple voltage divider circuit can be used as the resistance value of the thermistor will drop as the temperature rises causing the output voltage across the voltage divider to rise as well. A simple example of this circuit can be seen in Figure 3.3.2a below.

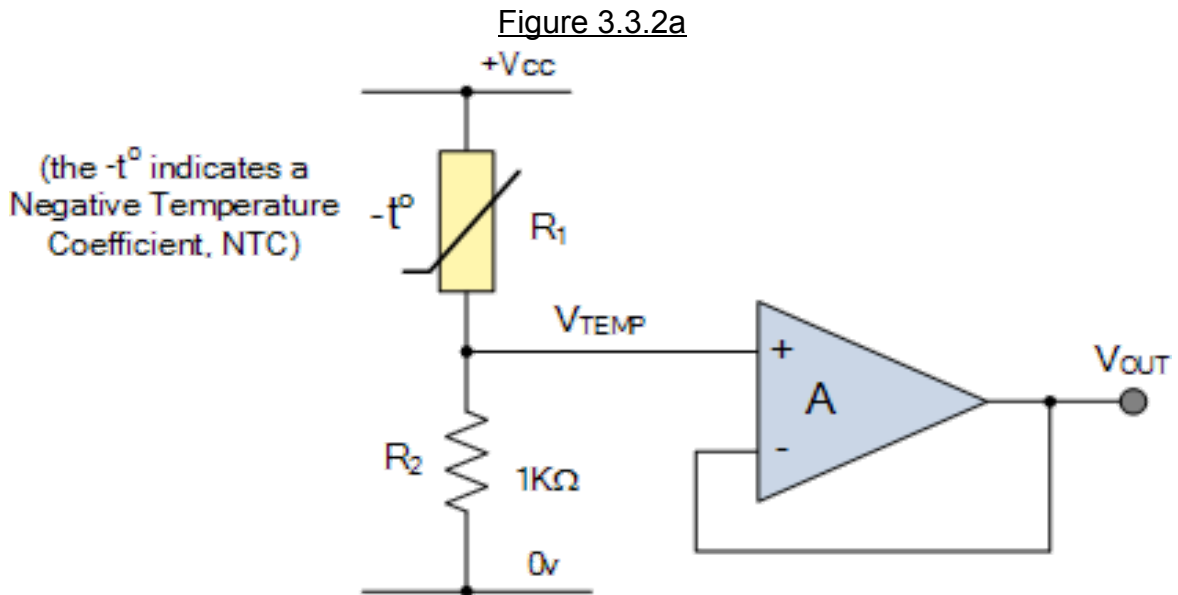

Permission to use Figure 3.3.2a given by electronics-tutorials.ws

In this example of a thermistor circuit, 12V is set as the +Vcc and the R_2 value is a constant 1K Ω . The voltage division is measured between the thermistor (R_1) and R_2 by the positive lead of an operational amplifier. The opamp is configured as a voltage follower so that the output V_{OUT} follows the input on the positive terminal coming from the voltage divider circuit. If the R_1 value at 75°F is 10K Ω , then using the voltage divider equation, $V_{OUT} = \frac{R_2}{R_1+R_2}V_{CC} = \frac{1K}{10K+1K}12 = 1.09V$. From here, the temperature sensor could be calibrated by raising the temperature and noting the voltage changes as temperature increases across the range of values that would be use for your situation (www.electronics-tutorials.ws, 2015). In the case of a smart grill, if one were looking for the internal temperature of the meat to reach 425°F, after calibrating the sensor if you knew that the resistance of R_1 becomes 250 Ω at that temperature, you could have your microcontroller looking for the corresponding output voltage indicating that the temperature has been reached. To find the output voltage at that temperature you would again use: $V_{OUT} = \frac{1K}{250+1K}12 = 9.6V$. From this point, to implement this into your design your microcontroller would look for 9.6V to indicate that the food has finished cooking completely. The most difficult part of implementing this type of sensor is the initial calibration, however once all values are known the rest is very straight forward.

3.3.3 Resistive Temperature Detector (RTD)

Much like the thermistor, RTDs are composed of metals that change resistance values as temperature changes. The advantage of using an RTD is that they are linear devices so a voltage divider network isn't necessary for them to work properly. The thermistor does not function linearly so without the voltage divider it would be hard to predict resistance value as temperature changes. The RTD adds the convenience of needing less hardware for it to function properly. The downside to a RTD is that they have, "a base resistance of about 100Ω at 0°C, increasing to about 140Ω at 100°C with an operating temperature range of between -200 and +600°C" (www.electronics-tutorials.ws, 2015). This minute change in resistance value could make this device not as sensitive as a thermistor and would be less ideal for a smart grill as thermal sensitivity is important to ensure that the item being cooked is not burned.

3.3.4 Thermocouple

A thermocouple is another temperature sensing device that could be useful when it comes to measuring temperature from the smart grill. A thermocouple has advantages over the thermistor as it allows for a wider range of operating temperatures depending on the materials being used. A thermocouple works rather simply and somewhat similarly to a thermistor. Figure 3.3.4a shows a typical setup of a thermocouple to explain how it works for the purposes of our project.

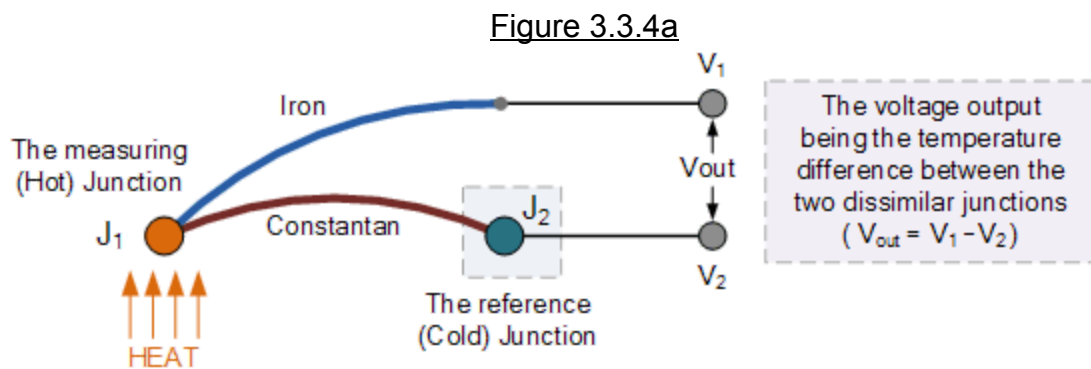

Permission to use Figure 3.3.4a given by electronics-tutorials.ws

The thermocouple has two different metals joined together at J_1 which is where the heat is sensed. The metals will create a difference in voltage across them as long as J_2 is held at a constant reference temperature. This voltage at V_{OUT} can be measured by the microcontroller much like when using a thermistor. If the grill was at the same temperature as the outside reference point, there would be no voltage difference across the terminals and the microcontroller would be able to

sense that the grill was not on. As the temperature of the grill increases there will be a larger voltage potential which would correspond to the actual grill temperature. If we were to use a thermocouple for temperature measurements for the smart grill, a thermocouple made of iron and constantan, like the one shown in Figure 3.3.4a, would offer a sensing range between 0°C to 750°C which would be more than enough to measure the operating temperature of the grill (www.electronics-tutorials.ws, 2015). A potential downside to the thermocouple is that the reference junction may be subjected to varying temperatures depending on if the grill is used inside or outside or on an hot or cold day. This difference in reference temperature may negatively affect the calibration and cause issues in reaching the appropriate cooking temperature depending on the environment the grill is being used in.

3.4 Electric Burners

Electric Burners are the cooking surfaces that the food is cooked on. The Burners are typically coil style, which is a flattened spiral of electrical wire sheathed in a conductive metal that heats up when power is supplied to it. Electricity flows wire.

Electric burners are relatively flat so the food comes in direct contact with the burner heating the food evenly. When the food is placed on the electric burner, the burner conducts most of its energy (which is about 75%) directly into the pan rather than radiating it into the air as a gas flame would. Most of the heat is transferred by conduction. Conduction is the transfer of heat by direct contact between two or more surfaces. For our project this would obviously be direct contact between the food and the metal burners. When the food is placed on the burners thermal energy from the burners is transferred to the colder food as the neighboring molecules distribute kinetic energy to equalize the temperature. Smart Grill in already has a power outlet plug which hooks up directly to our 1800W burners. However, controlling our burners takes more understanding. In order to control an electric burner or element we had to understand how they actually work. For instance, voltages of 120V and currents of 10A to 15A that are needed to operate the electric burners in normal operating conditions. An electric grill heats up its food by generating intense radiant heat (with temperatures anywhere from 200°F up to 700°F) which powers on and off thus reenergizing its heat coils intermittently on a timer or if the temperature drops. Therefore, searing foods may not be possible as it requires intense heat for long durations of time, even if it's only for 2-3 seconds.

The burners that we will be using for the Smart Grill will have 200 square inches of usable cooking space. This consists of a Reflector Pan and a Cooking Grid shown below in figure 3.5a.

Figure 3.5a



3.5 Power supplies

I began my research for Smart Grill power supplies by first looking at our high current and high voltage systems, of 15A and 120V respectively, together and our low current and low voltage, of 15A and 5V/12V respectively, systems together. The 2 burners that Smart Grill uses will have to be at 120V, therefore I focused my attention to how the burners actually accept power from the wall outlet and battery. In doing so I realized that the burners do not need 1800W AC power to operate under normal conditions. 1800W DC voltage and current will work the same due the burner being a resistive system and therefore is not affected by phase and frequency.

Powering an electric heating element, that in today's industry features ~250W to 2500W units is relatively simple, mainly because the grill chassis we are housing

Smart Grill in already has a power outlet plug which hooks up directly to our 1800W burners. However, controlling our burners takes more understanding. In order to control an electric burner or element we had to understand how they actually work. For instance, voltages of 120V and currents of 10A to 15A that are needed to operate the electric burners in normal operating conditions. An electric grill heats up its food by generating intense radiant heat (with temperatures anywhere from 200°F up to 700°F) which powers on and off thus reenergizing its heat coils intermittently on a timer or if the temperature drops. Therefore, searing foods may not be possible as it requires intense heat for long durations of time, even if it's only for 2-3 seconds. The component that allows the re-energizing of the heat coils is the burner switch, also called an infinite heat switch. They are referred to infinite because they control heat from high to low and everywhere in between.

3.5.1 Infinite Heat Switch

This component in our power design is the most infamous component for causing danger and in some cases a fire. Luckily, our pre-assembled chassis already includes a infinite switch that integrates with our grill unit. However, we may need to implement our own in order for the LCD touch screen display to be able to change the temperature settings as well. For this reason, it is still important to cover all possible research and practice all safety procedures to ensure no injuries occur before, during or after working on Smart Grill.

Figure 3.5.1a

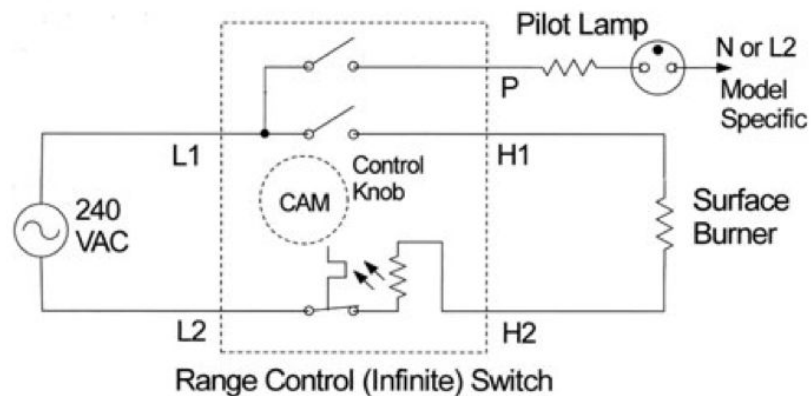

As seen above in Figure 3.5.1a the typical infinite switch which uses an approximate wattage range of 100W to 3600W and basically works by pulsing up

to 15A of current on and off for intervals determined by the dial setting. The actual control is effected via a bi-metal switch that moves as it is heated. The switch's heater element is in series with the range element, however the series heater will only dissipate a small percentage of the main voltage. This means that a higher wattage element will reduce output for a given setting and have an increasing time of getting hot. The Figure 3.5.1b below is a schematic of a common infinite switch implemented with an element and wall outlet power source. The switch is hooked up in parallel between the source and the burners. L1 and L2 represent line connections thesaurus, H1 H2 represent load connections and the pilot lamp which is not in use is used for an LED indicator. The switch operates by having three indexing positions HIGH OFF LOW which determine what does switch does. In the HIGH position the control is energized continuously. In the OFF position the double line is disconnected and if in the LOW position that controls the liver the selected level of input via the timer.

Figure 3.5.1b

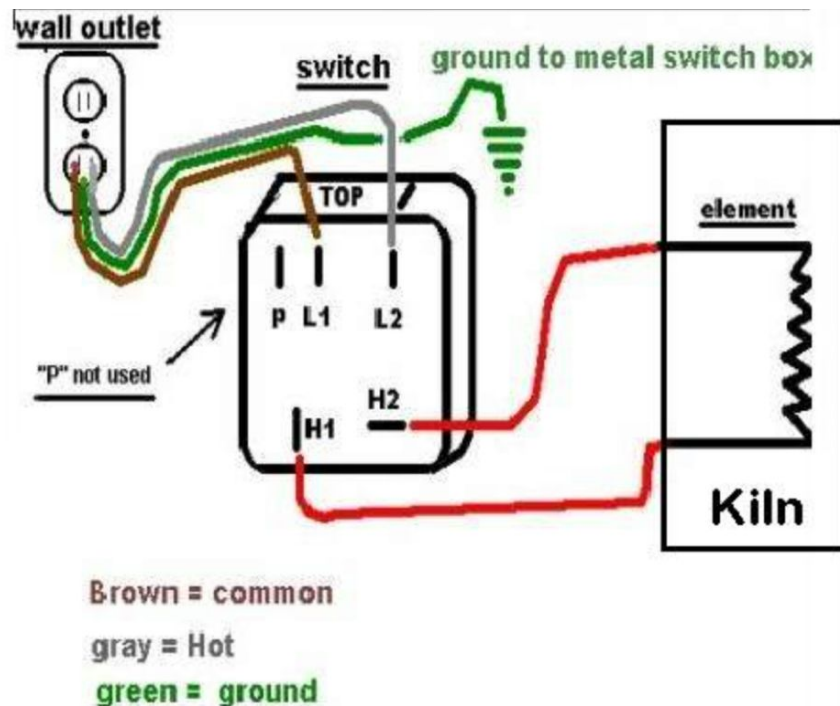

Permission to use Figure 3.5.1b given by Flint Knapping Tools

The basic Smart Grill operation is as follows, the user determines a set temperature, when the heater is cold the switch, H1 & H2, is on and the range element will be turned on to heat up the element to the set temperature. By the use of a switch in series the element switches on and off really fast in order to reach a user-defined set temperature via the control system. It is to our teams knowledge that the burners do not go completely off or rather partially off so not

to have any sharp current spikes. This means that burners are essentially binary in that they are either fully on or fully off.

Older heating elements are purely resistive meaning when the burner is set to low there's less current and when the burner is set to high there is more current flowing through the element. Therefore, the heating element has a fixed resistance but will change somewhat with age. Newer heating elements operate with an infrared lamp instead of a resistive wire. Therefore, a coil stove is the same as a glass ceramic stove top the only difference is that the coil is not clear but if it was the same heating on and off patterns would be visible. However, in both the actual load in the element has no effect on timing. Although if you increase the wattage of the element it will reduce the output for a given temperature setting and increase the time it takes to reach that set temperature.

3.5.2 Batteries

The next dangerous and therefore needed to discuss topic are batteries. A 12V battery works by converting about 2 million Joules of chemical energy to electrical energy by separating cells. When the battery is connected to a circuit the chemical reactions inside the battery begin and the current starts flowing from the power generating compartments called cells. For 12V batteries anywhere from 2A to 30A of current can be supplied. There are about 2V per cell or 6 cells for 12V lead acid battery which rearrange themselves to form two electrical terminals. This chemical energy can not be sustained indefinitely and therefore the battery will eventually discharge completely. Therefore, at least an 1800W battery charger will need to be implemented into Smart Grill in order to make the battery power source practical. The battery charger basically works by feeding some current through the batteries for a period of time with the hopes that each cell inside will hold on to some of the energy passing through them. Overcharging is generally worse than undercharging. If you do not switch off the charger the battery will build up extra energy and try to dissipate this as heat. Temperatures over 580°F for lead acid and 930°F for lithium ion will cause a buildup of pressure inside which could possibly make it explode.

Today's industries chargers are more sophisticated in that they can switch themselves off after a period of time and feature intelligent microchip based circuit in order to sense how much charge is stored in the batteries so that they can be more accurate with the over and under charging average time for that specific battery given its current status and condition. The Different types of rechargeable batteries correspond with different types of charging. There are four main different types of batteries which include: nickel cadmium which are the oldest commercial use battery being on the market in 1950. This battery has the longest cycle time of 1500 cycles however it has the second highest self discharge rate of 20%. Nickel metal hydride which is similar but able to store

more charge has the highest self discharge rate of 30%. Both of these nickel based batteries have 1.25V cells. Although, these two batteries are subjected to what experts know as the memory effect their overcharge tolerance is good. The memory effect occurs when you repeatedly recharge your battery before it reaches a fully discharged state, essentially topping it off. The battery will then have a mind of its own and temporarily think it has a lower voltage and charge storage capacity than it should have. Another the thing to be aware of with these two batteries is that there is a generally agreed on premonition that these nickel based batteries need to be primed or charged fully before they're used for the first time.

The next type of battery researched was the lead acid battery. These are the biggest heaviest and oldest, being invented in 1859 rechargeable batteries are most familiar to us as car batteries which take up to a day to charge and last only for 300 cycles, however, only self discharge about only 5%, cost much less and have a small internal resistance less than 100 Ω . The last type I considered for my design is a lithium ion rechargeable battery. These batteries are mostly known to be in hand-held appliances and have to up 1000 cycles. They are 3.6V cells and are the most expensive batteries and have a self discharge rate of about 10% and internal self resistance of 2X as much as a lead acid battery. Lithium ion batteries can become dangerously unstable if either overcharged or undercharged, therefore protection from operation under these conditions you should be carefully designed. It's important to note that these batteries don't show the memory effect but they do degrade as they get older.

In order for Smart Grill to draw power from a battery in the event that no power outlet is available we would need a few power relays to switch from battery and power outlet remotely. Last but not least, we need to have a power relay to switch the battery charger on when the system is in OFF mode and plugged into the wall outlet. Since we are trying to decrease our costs as much as possible, I decided to implement a 12V rechargeable battery that is rated at about 30A. For the most part, all the current lead acid and lithium ion batteries on the market are durable, safe and last long enough for Smart Grill to operate in normal conditions. To choose the right battery composition for Smart Grill required us to look at all their advantages and disadvantages and match them to our specifications. Some of the lithium ion advantages that favored Smart Grill are a flat and constant discharge voltage vs time graph. This ends up working out to about 2X as long cycle and lifetimes and thus less frequent maintenance checkups. The state-of-charge calculation is also more exact by coulomb counting rather than a rough voltage level. Some of the lithium ion disadvantages that should be realized for the sake of Smart Grill are the costs associated with lithium ion batteries are much higher than lead acid. However, this is only typically true for larger systems because of the protection circuitry which can be custom and expensive. Our group decided to go with the lead acid battery because it is very reliable and great for outdoor conditions.

I wanted to also add a battery charge indicator or fuel gauge. When power from the wall receptacle is not available a battery must be used to power Smart Grill. This is an accurate timing prediction to know how much power remains on the battery can enhance the user's grilling experience. Battery gauging basically works by applying a controlled discharge to make a chemical battery a digital or discrete one. By estimating the capacity when charging and discharging while under a constant load the coulombs in the battery are then counted. As the battery starts to age the capacity drops and the accuracy of the fuel gauge considerably decreases. One important thing to realize is that the output of the fuel gauge does not guarantee runtime, because it resets to 100% regardless of how much capacity the battery can store. The only constraint that the battery needs to have for Smart Grill is that its accuracy must be measured within an error margin of 10% and 10 bits of ADC resolution.

Battery fuel gauges have become an essential part before handheld systems, however I wanted to bring this functionality into smart grill. Although there are a number of things that fuel gauging circuits do, the main purpose of using a gauging circuit on Smart Grill is to accurately gauge how much time is left for you to know how long you have to use the 12V on board battery as a power source. That way you know how much grilling time you have total so you can determine whether or not you should even start the grill and be getting real in the first place. Today's industries fuel gauging solutions offer the ability to properly manage available power by alerting the user of system operating time as well as extending runtime. This enables the system to use every last drop of the battery power without an unexpected shutdown.

Battery fuel gauging works depending on the type of battery used. For lead acid batteries the technique to gauge the capacity of the battery is determined by a rough voltage level reading across the terminals. As for lithium ion batteries the technique used to gauge capacity of the battery is determined by a much more efficient and exact method called Coulomb counting. The accuracy of fuel gauging, which is about ± 50 mV for lithium ion batteries, has been trademarked by leading companies such as Texas Instruments. They proved that the key variable in discharge capacity variation is the impedance of the battery cells. TI offers solutions for batteries of 1 to 16 cells and also honed its skillful approach with their impedance based battery fuel gauging method called Impedance Track. The Impedance Track proprietary algorithm made in 2004 uses voltage and current measurements as well as temperature and battery characteristics to determine state-of-charge, state-of-health and capacity. The basic idea of impedance track is measures in stores in real time the batteries resistance as a function of state of charge. These real-time resistance profiles along with the reference open circuit battery voltage enables the gauge to predict the batteries discharge curve under any temperature or system-use condition load.

In Figure 3.5.2a is a generic block diagram of a charging system. The current control block limits the maximum current delivered to the battery in the voltage control block maintains a constant voltage on the battery. The temperature in time control blocks are used as measurement systems and all for control blocks are used in a calculation in the intelligence block. The intelligence block knows how and when to perform the four stages in the figure 3.5.2b. The Figure 3.5.2b represents four stages in which a battery undergoes its general charging process. The first stage of charging is the constant current stage in which as soon as you start charging the battery gives a constant current until the battery reaches its voltage. The second stage is the saturation stage in which the battery reaches its peak charge the current steadily decreases until it gets below a certain value and then terminates. Stage 3 is when the charge terminates and no current is given to the battery. Stage 4 is the occasional topping of the charge under stand by operating conditions.

Figure 3.5.2a

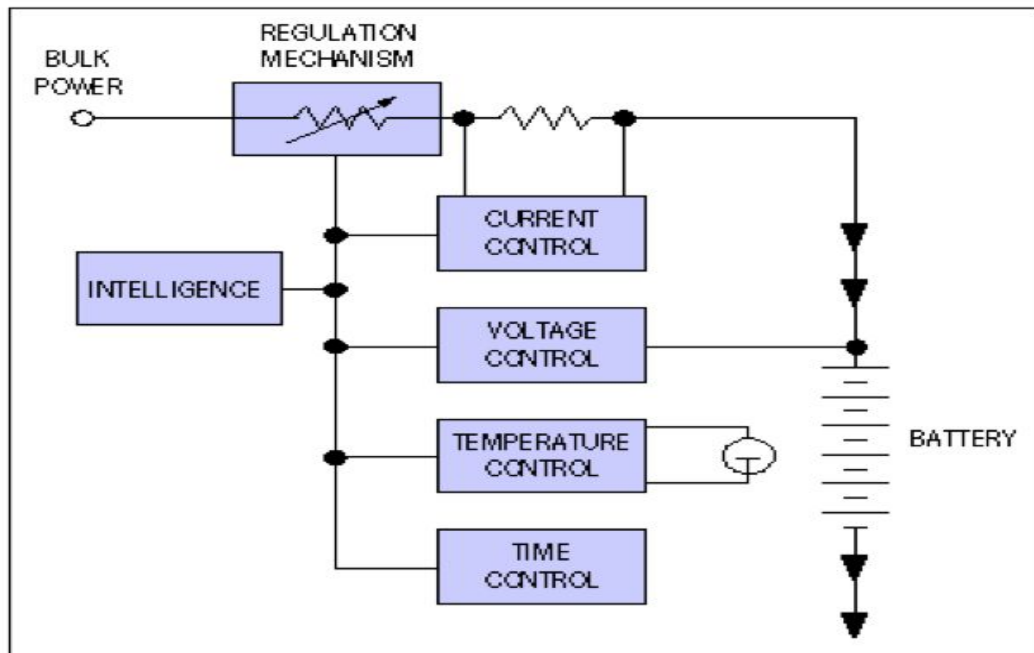

Permission to use Figure 3.5.2a given by Maxim Integrated

Besides charging and fuel gauging there are two other comprehensive integrated circuits that can be utilized and implemented with Smart Grill. Battery management in the form of protection from over/under voltage and overcurrent

conditions, which will be implemented in the fuel gauging and charging integrated circuits. The last form of battery management, which we won't utilize, is authentication of host system and peripheral compatibility. These two battery management techniques will not be needed for the applications that smart grill entails and therefore will not be discussed. One important thing to realize is that the output of the fuel gauge does not guarantee runtime, because it resets to 100% regardless of how much capacity the battery can store. The only constraint that the battery needs to have for Smart Grill is that its accuracy must be measured within an error margin of 10% and 10 bits of ADC resolution.

Figure 3.5.2b

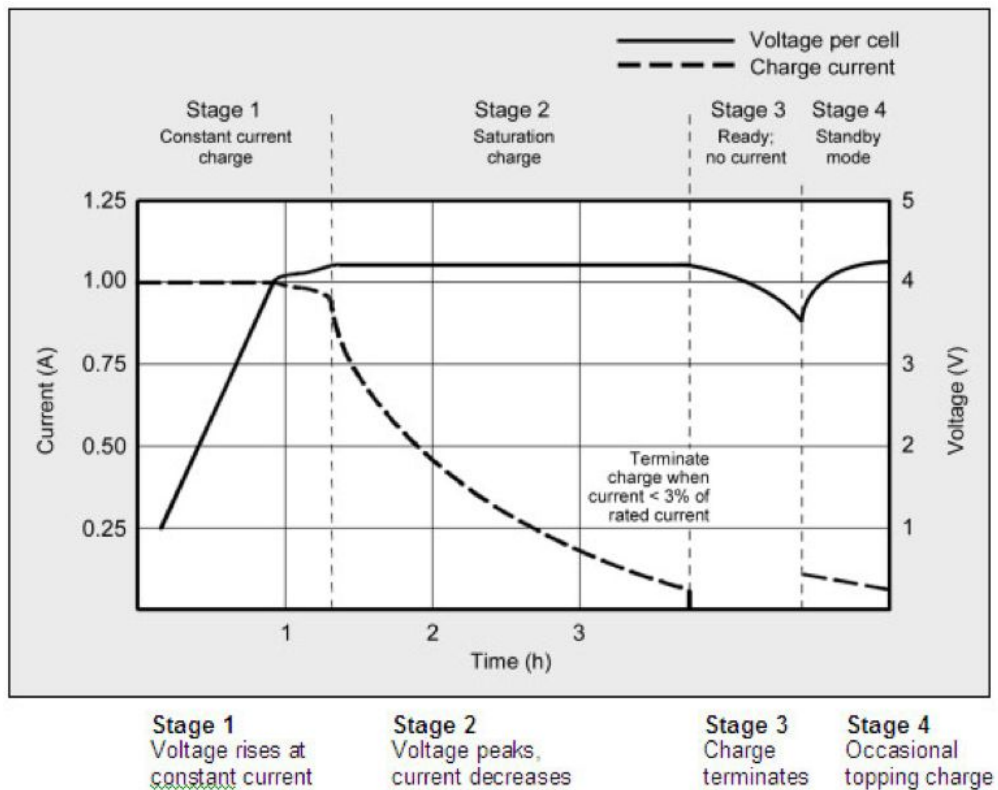

Permission to use Figure 3.5.2b given by Battery University

3.5.3 Voltage Regulators

What's common in all home appliances that are electric in today's world is power regulation. And therefore a power regulator IC will be needed. A power IC has the ability to regulate the voltage in order to keep all of the subsystems operating at the required specification voltage range. A power IC inputs unregulated voltage and outputs a regulated voltage. Sometimes the regulator has the ability to change the input voltage up or down in value. The first regulator under discussion is the linear regulator or LDO - low dropout can produce a voltage lower than the supply voltage but not higher. So the linear regulator is only a buck converter or step down converter. The only difference between LDO and a standard linear regulator is that the LDO can operate with a very small voltage drop difference between the regulated output and the unregulated input voltage. An LDO might have a dropout voltage of 0.3 volts or less where a standard linear regulator offers a drop out of 1 volt or more. A low dropout voltage makes a good choice for portable and battery-powered applications such as the Smart Grill. Some of the other advantages of the linear regulator are inexpensive, low noise and small size. However, the linear regulator is very inefficient at as about 27% and as high as about 95% from a switching regulator. Since the linear regulator dissipates a lot of unused power as heat our group chose to regulate the 5V and 12V power supply for the MCU logic signals is a switching regulator.

The Figure 3.5.3 illustrates one of the biggest differences and most influential reasons for choosing which regulator was right for smart grill. The figure basically shows that a linear regulator will give you the same efficiency at any output current. On the other hand this figure also illustrates that a switching regulator has different efficiencies at different output currents due to the nature of their operation. Seeing that the switching regulator was much more efficient than a linear regulator I thought why not be more efficient wherever possible not to mention it's lighter and will not need as much cooling. Basically a regulator provides the steady voltage because the regulators active circuitry has an output resistance much much lower than the battery's internal resistance and therefore the varying circuitry resistance from the rest of the circuit does not affect the varying current which is being pulled from the battery. A regulator ensures that the circuitry receives the appropriate voltage regardless of whether the power source comes from a power outlet receptacle from the wall or a battery from within the grill.

Figure 3.5.3

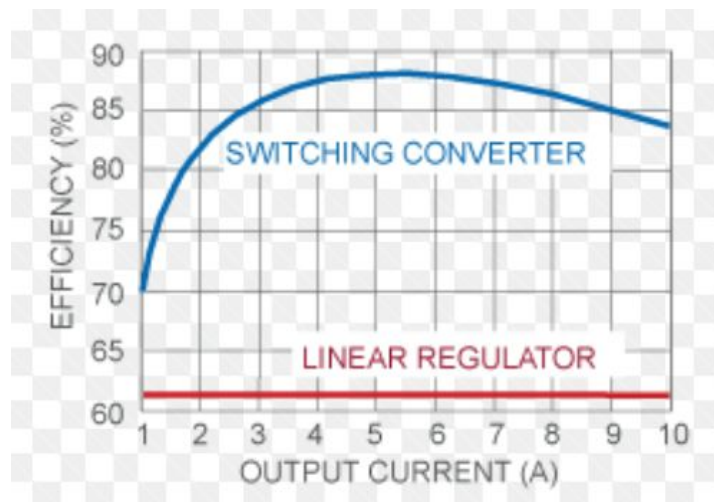

Permission to use Figure 3.5.3 given by Intersil

Unfortunately, the switching regulator does not share any of the advantages of the linear regulator. Switching regulators for the most part consume more area than linear regulators do. They cost more, generate more noise but has still been able to remain enormously popular in the world of power design systems. The reason is their efficiency is excellent when subjected to many different input voltages and load currents. The understanding of this lies behind how a switching regulator regulates its voltage. A switching regulator works by using a power transistor as a switch in conjunction with an inductor to convert one voltage to another. The faster the switching regulator switches or the transition between the switches gets faster it also improves the regulators efficiency. The power that is lost from transistor on state to transistor off state will depends how efficient the switching regulator is. When the transistor is off no current flows and therefore there is no power dissipation. However, when the transistor turns on a small voltage appears across the transistor and current may flow through thus when the switch transitions from on to off or vice versa a small amount of power is lost. Speeding up the switching process reduces the transition losses. Since micro processor and memory operate at a high speed the majority of the circuitry in our system will need to operate within a narrow voltage range. A regulator ensures that the circuitry receives the appropriate voltage regardless of whether the power source comes from a power outlet receptacle from the wall or a battery from within the grill.

Another issue within the battery that can present a problem if no regulator is used is the internal resistance of the battery. Due to the circuitry needing different operating voltages the circuitry also needs different operating currents. When varying current is drawn from the battery, varying battery voltage will be therefore created due to the battery's internal resistance. The power supply rejection ratio

or PSRR is the ability of the circuitry to object the variations of battery voltage. To help deal with this problem a regulator is used to maintain a steady output voltage despite varying load currents. Basically a regulator provides the steady voltage because the regulators active circuitry has an output resistance much much lower than the battery's internal resistance and therefore the varying circuitry resistance from the rest of the circuit does not affect the varying current which is being pulled from the battery.

The efficiency on a switching regulator can be as high as 96% for both step up and step down switchers however step down is usually more efficient. Another thing that the switching regulator can do besides step up and down voltage is invert the voltage. Efficiencies of the switching regulator inverter can go as high as 90% the switching regulator converter inverter can go as high as 90%. It is critical that the efficiency and performance of the parts in the power system are optimized. If these components do not perform properly and have low efficiency levels, then it degrades the project's functionality as a whole. Consider the device outputs that will provide power for subsystems. If the components that take the input power from the battery or wall receptacle and provide DC or AC output power is not efficient or functions improperly, there is a good chance the components that take the regulated power from the battery and wall receptacle and provide AC or DC power will perform much more effectively with high efficiency.

3.5.4 Power Relays

Power relays are typically discussed in terms of several things such as rating in amps and voltage and power type (AC or DC) the coil needs to operate and the number and type of contacts the relay has. The first thing we need to discuss is the power rating. We can say that a relay is rated for its capacity to handle power. The relays we have been searching were described as several different values of current up to 40A. We realize that the relay rating must be higher than the maximum rating of the appliances we will test our system on. The second thing is the coil voltage and type. This characteristic is typically omitted when working in a known environment. The third thing is the number and type of contacts. This characteristic is used to control various things at once and control them by turning them on or by turning them off. The number of contacts or poles is the number of things that the relay can control at once. The relay is just an electromagnetically controlled switch. Those contacts or so called poles are described as "normally open" (NO) or "normally closed" (NC). This simply describes what the rest state means. For a power relay, that means if no power is applied to the coil wire. In the typical case where a user wants to turn something on, we would use a normally open relay because when we apply power to the relay, the contacts close, and power is sent to the desired device. In our case however, we want the relay to be able to turn things off. Therefore, we

will choose a normally closed relay. So when we apply the power to the relay, all the contacts have to do is open and the power is no longer sent to the specified appliance or device.

A solid state relay SSR is an electronic device we can use to switch the electrical current, rather than an electromechanical device. An electromechanical relay uses a magnetic coil and mechanical contacts. When current flows through the coil, it pulls down a piece of iron called an armature, causing the mechanical contacts to touch and thus close an electrical circuit. We had the choice of either a solid state relay or a mechanical relay. The solid state relay has no mechanical moving parts, but instead uses a three terminal device such as a TRIAC, a back to back thyristors, or a field effect transistor FET to conduct the electrical current. When the third terminal is energized by the control input, the device conducts. Essentially the solid state relay controls a larger electrical current by accepting a small control signal. A main benefit of using it would be the fact that there are no moving parts. Also solid state relays have no internal arcing or contacts to wear out, so they can last virtually forever. They also have extremely low control input requirements, and are immune to vibration.

Other considerations that have led to our choice were the fact that the solid state relays are typically smaller than the electromechanical relays. This will help us conserve valuable space in printed-circuit board applications. Also, the solid state relays offer improved system reliability because they have no moving parts or contacts to degrade. Adding to that, solid state relays provide high performance, including no requirement for driver electronics and bounce free switching. They provide improved system life cycle costs, including simplified designs with reduced power supply and heat dissipation requirements. Another benefit would be the possibility of using a solid state relay as surface mount technology parts, which means lower cost and easier surface mounting technology printed circuit board manufacture.

The other type of SSR that applies to Smart Grill is the power MOSFET. The Figure 3.5.4a, as seen below, is a general implementation of a MOSFET switch. Since there are both scenarios where a P-channel and and channel MOSFET will be needed in smart grid power system I decided to look at generally how the MOSFET was implemented to act as a switch. The P-channel MOSFET switch is shown with the source on the supply and the drain attached to the load. The gate is obviously used to switch the power supply on and off of the load by applying a voltage equal to the supply.

Figure 3.5.4a

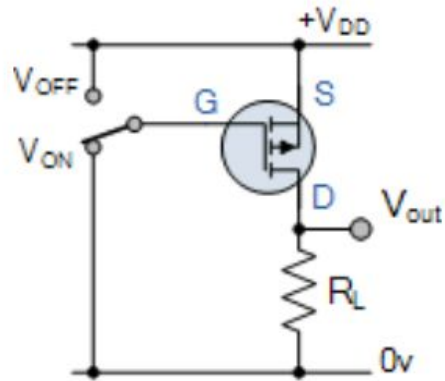

P-channel MOSFET Switch

Permission to use Figure 3.5.4a given by Electronics Tutorials

Where in Figure 3.5.4b illustrates a PMOS between a supply and a load, NMOS is usually placed between a load and ground in order to pull the ground down and activate a mechanism such as a motor which is always powered. The figure below illustrates NMOS to be implemented in a logic design for a DC motor which is very similar to what we will be using to control our rotisserie motor with the MCU.

Figure 3.5.4b

Simple Power MOSFET Motor Controller

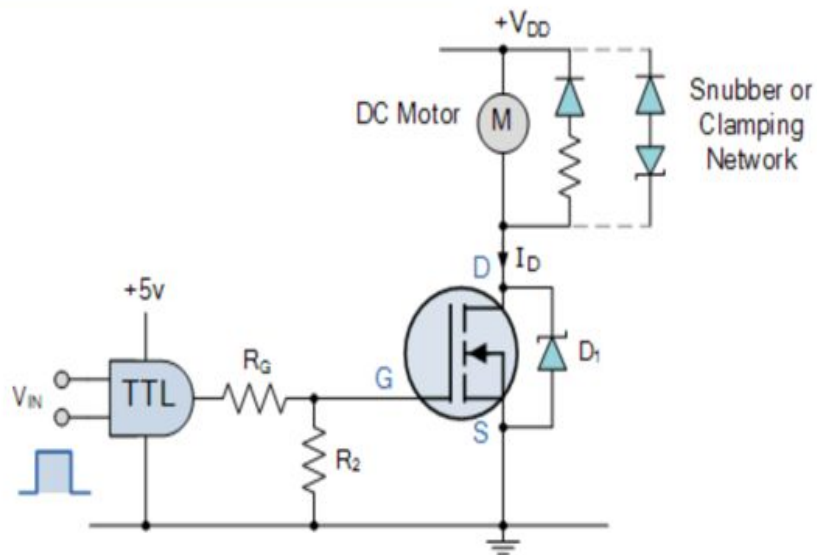

Permission to use Figure 3.5.4b given by Electronics Tutorials

Another issue with the electromechanical relay would be the bounce time. The maximum bounce time of an electromechanical is the period from the first to the last closing or opening of a relay contact during the changeover to the other switching position. Bouncing causes short term contact interruptions. In our case, bounce can easily lead to false pulse counting as contacts continue to make and break the circuit during bounce. Contact bounce does not occur in semiconductor based solid state relays as seen in Figure 3.5.4c in which the bounce is shown for a mechanical switch actuation.

Figure 3.5.4c

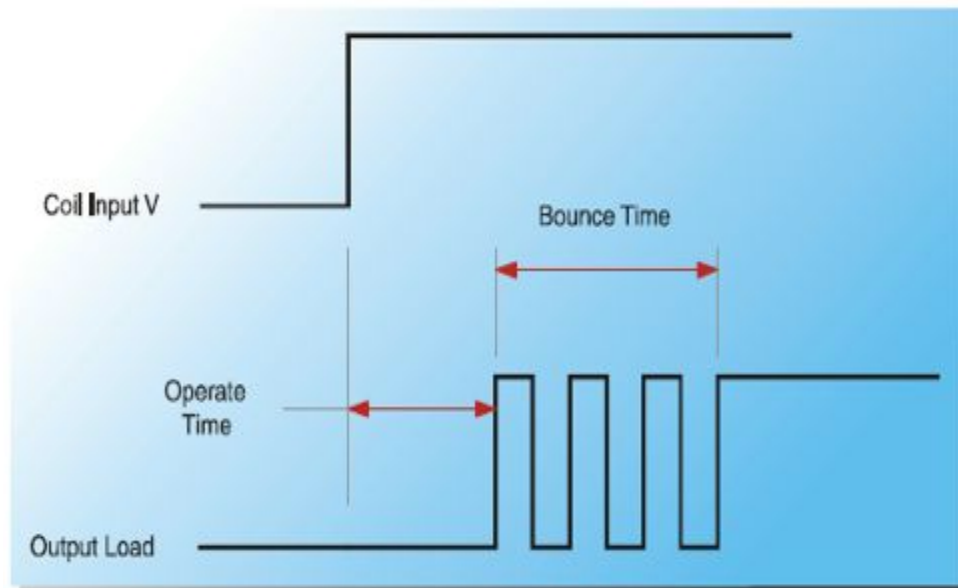

Figure 3.5.4c Permission to use Figure 3.5.4c given by Clare.com

Since solid state relays do not have contacts, wear issues are not of our concern. The absence of contacts and moving parts means that the solid state relays are not subject to arcing and do not wear out. Contacts on the electromechanical relay on the other hand can be replaced on some larger relays but contact replacement is not practical. Another issue with the electromechanical relay would be the shorted coils. Shorted coils can occur if excessive heat melts the coil insulation. Open coils can be caused by overvoltage or overcurrent conditions applied to the coil. The circuitry used to drive the electromechanical relay can cause open coil failures if the drive circuit itself fails or is subjected to transients. Solid state relays can be driven directly from logic circuits, so an intermediate drive circuit is not required. AC load solid state relay have the

benefit of zero crossing switching which reduces noise in the circuit by restricting the switching operations to the point where the voltage crosses zero.

Since a solid state relay will be used. A possible configuration is considered. The relay will be connected to the load and to a control voltage. The sensitivity the minimum control voltage and current at the solid state relay turns on depends on the characteristics of the isolating component or circuit and will be documented in the relay data sheet. The following Figure 3.5.4d shows a possible configuration of the relay circuit.

Figure 3.5.4d

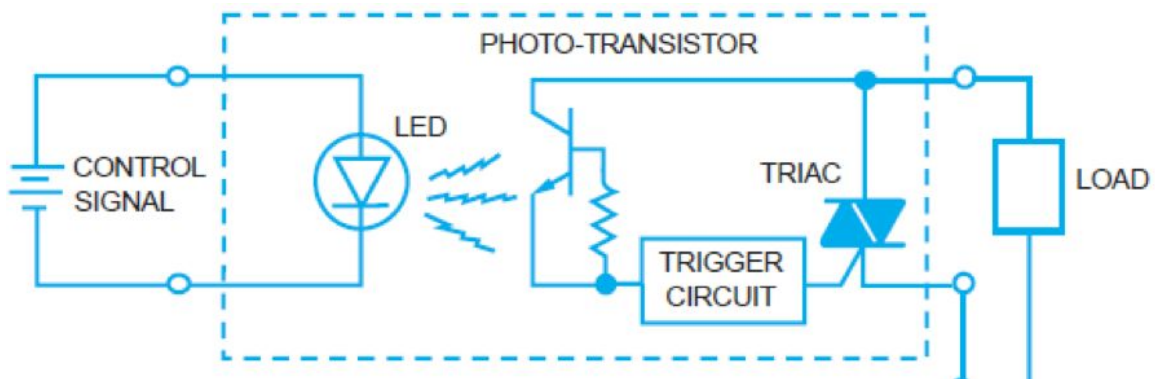

Permission to use Figure 3.5.4d given by omega.com

Electromechanical relays are all around a good solution and much more robust than solid state relays are, however they are big in size and have a longer switching speed as well as shorter mechanical lifetime. On the other hand, solid state relays are a nice alternative and offer very high switching speeds but are not fully isolated between the Contacts and thus there is unwanted extra contact resistance. It is important to note that if a power switch is needed between a load and ground an N-channel MOSFET is used where a P-channel MOSFET is placed between a reference signal and a load. This of course is just a convention and can be designed with either power MOSFET in place. It would be important to note that an N-channel MOSFET can be turned on by putting a positive voltage on the gate and a P-channel MOSFET can be turned on by grounding the gate.

3.5.5 Transformers

Since smart grill will need to step down as well as step up its voltage in certain conditions a voltage transformer will need to be implemented in the power design. There are two types of voltage transformers what are step up and step down transformers. They work on the principle of magnetic induction in which the primary coil that induces a voltage on a secondary coil that are wrapped around

a piece of metal. Where the ratio of windings of primary to secondary is equal to the voltage from primary to secondary. After Researching I started to realize that step up or down transformers rated at a few amps are relatively cheaper to make, however when researching transformers of a high amperage rating for instance the 30 amps needed run smart grills burners in parallel I would essentially need a transformer rated at the same wattage as my burners are in order to not blow things up. These are big and bulky as well as expensive so making one is out of the question. So I decided to buy one with the hopes of possibly using it in the future for my new truck. The step up transformer that our group decided on was heavily reliant on money constraints. In order for Smart Grills subsystems to get all the required voltages to operate in normal conditions in order for Smart Grill's subsystems to get all the required voltage use to operate in normal conditions our group simply decided to use step up and step down transformers in order to reach the required voltages needed. We decided not to use boost and buck regulators to step up and down the 12V and 120V converters we need. However, because efficiency is not important in this aspect and mainly because we are dealing with high voltages and currents our group chose to step up as well as down the voltage required for the burners with transformers. A transformer operates on electromagnetic induction. A varying current in the transformers primary creates a magnetic flux in the core then is induced as a varying magnetic field on the transformer secondary. If the number of windings in the primary coil is bigger than the number of windings in the secondary coil then this is a step down transformer And vice versa for a step up transformer. It is possible to transform current however for Smart Grill's power system and subsystems this will not be necessary. The step up and step down transformers needed in the power system for smart grill includes one step up transformer for the batteries 12 volt supply to be transformed to 120 volts for the burners to operate under normal operating conditions, as well as a step down transformer to be used for the logic design of smart grill and be implemented between the power supply from the wall outlet at 120 volts to be stepped down for the microcontroller at 5 volts and motor at 12 volts.

3.5.6 Rectifiers

What's very common in many power systems is to have a rectifier after the transformer. For the power system of Smart Grill there will only need to be one rectifier which full wave rectifies the 12v step down transformer output before the 5v and 12v regulators feed the microcontroller. A half wave rectifier uses one diode and a full wave rectifier uses four diodes shoe control the flow of current in the positive direction as well as the negative direction to eventually reach the output whether the input is negative or positive. A capacitor is used in order to smooth out the full wave into a DC signal with a ripple current that's dependent on the size of the capacitor. Because our group will be working with voltages higher than 5 volts I wanted to research a little bit about the dangers of working

with high voltages and high currents. It's important to understand that even even a few milliamps of current can be fatal and it doesn't take a large voltage either. The more important aspect was electrostatic discharge and how we can reduce the risk of shocking ourselves by touching our skin to a potential which is greater than the zero volt ground potential which we are standing on while working. For the power system and our safety, it is important that high voltage and current precautions take place. We can do this by metering all the voltages as well as wearing the proper attire with safety gloves where The buddy system will always be used. For the low power logic applications of smart grill it will be wise for us to use ESD or electrostatic discharge protection in order to avoid an ESD strike to permanently damage our PCB or PCB board components.

Figure 3.5.6

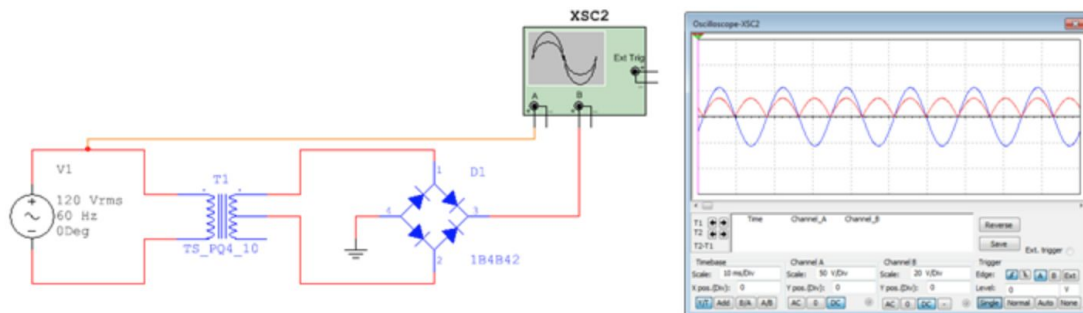







Permission to use Figure 3.5.6 given by National Instruments

A rectifier is commonly used in conjunction with a transformer in typical household power applications as seen in the figure below. The input voltage on the blue oscilloscope graph is 120 volts RMS and the red output of the oscilloscope is at a lower voltage and only positive due to the rectifier. It is later discussed in the power management section that this rectifier and transformer duo is exactly what we are looking for to properly design the circuits for the voltages required for smart grill to operate in normal conditions.

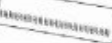
3.6 Grill Housings

The Grill Housing for the Meco 1500 - Watt Deluxe Electric Grill with Rotisserie consists of many parts. For the basic Grill housing we have identified these parts needed according to the Meco 9300 Series Electric Barbecue Grill Owner's and Operators Manual in Figures 3.6a and 3.6b.

ITEM	PART/DESCRIPTION	PART #	QTY.	MODEL
1	Owner's Manual 	03.5874.00	1	All 9300 Series
2	Hood/Bowl Assembly 	—	1	9300W Series (Window)
3	Hood/Bowl Assembly 	—	1	All 9300 Series (Non-Window)
4	Window Glass 	03.5107.00	1	All 9300 Window Series
5	Bolt Carriage #10-24 X 1/2" 	03.5108.01	2	All 9300 Window Series
6	Clip, Window Retainer 	17.5443.00	2	All 9300 Window Series
7	Wing Nut #10-24 	03.5750.00	2	All 9300 Window Series
8	Bolt #10-24 X 1/2" 	03.0201.02	5	All 9300 Series
9	Rotisserie Lock 	17.1698.00	1	All 9300 Series
10	Acorn Nut #10-24 	03.5000.55	1	All 9300 Series
11	Base, Table Top 	—	1	All 9300 Table Top Models









ITEM	PART/DESCRIPTION	PART #	QTY.	MODEL
12	Drip Cup 	03.6238.00	1	All 9300 Table Top Models
13	Crossbrace 	17.1679.18	2	9320, 9325 Models
14	Roller Leg 	17.1661.18	1	All 9500 Series Except 9350 Series
15	Fixed Leg 	17.1661.18	1	All 9300 Series Except 9350 Series
16	Bolt, #10-24 x 1 1/4" 	03.5007.00	12	All 9300 Series Except 9350 Series
17	Lock Nut #10-24 	03.0390.00	4	All 9300 Series
18	Wire Leg Shelf 	17.1699.00	1	All 9300 Series Except 9329
19	Leg Cap 	03.0735.00	2	All 9300 Series Except Table Top Models
20	Wood Leg Shelf 	18.1636.00	1	Models 9329
21	Top Frame 	18.1637.18	1	All 9300 Series Except 9350 Series
22	Insert Plug 	03.0734.00	4	9320, 9320W & 9321 Models Only
23	Bolt, #10-24 x 2" 	03.5007.01	4	All 9300 Series Except 9350 Series
24	Rivet Axle 	03.0104.05	2	All 9300 Series Cart Grills

Figure 3.6a

ITEM	PART/DESCRIPTION	PART #	QTY.	MODEL
25	Wheel 	03.5001.04	1	All 9300 Series Cart Grills
26	Wood Anvil 	03.0907.00	1	All 9300 Series Cart Grills
27	Axle Nut 	03.5000.10	2	All 9300 Series Cart Grills
28	Side Table 	18.5724.00	2	9325 Series
29	Utensil Hook 	03.5000.50	6	9325 Series
30	Holder, Drip Pan 	03.5144.00	1	All 9300 Series Cart Grills
31	Cooking Grid 	03.0710.00	1	All 9300 Series

ITEM	PART/DESCRIPTION	PART #	QTY.	MODEL
32	Pan, Foil Drip 	03.5143.00	1	All 9300 Series Cart Grills
33	Reflector Pan (Installed in Main Grill) 	17.5421.00	1	All 9300 Series
34	Rotisserie Motor (U.S. & Canada) 	03.5002.00	1	9329 & 9359 Window Models
35	Spit Shaft 	17.1529.00	1	9329 & 9359 Window Models
36	Spit Fork 	03.5750.00	1	9329 & 9359 Window Models
37	Bracket, Motor Mounting 	17.5419.11	1	9329 & 9359 Window Models

Figure 3.6b

We will be incorporating a rotisserie feature to our Smart Grill using several parts from the Meco 1500 - Watt Deluxe Electric Grill Rotisserie feature. Figure 3.6c shows the Model 1290-120 Volt Electric Grill. This figure and Table 3.6c identifies the main parts we will be incorporating according to Meco Rotisserie Assembly Instruction manual.

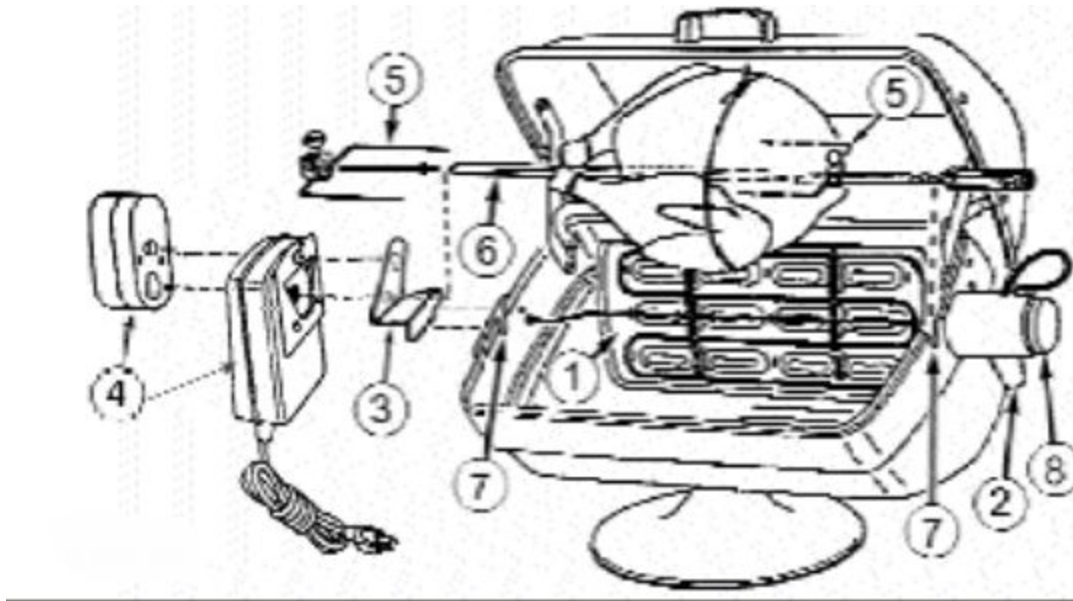

Figure 3.6c

Number	Nomenclature	Quantity
1	Burner Element	1
2	Control Knob	1
3	Motor Bracket	1
4	Motor	1
5	Spit Fork	1
6	Spit Shaft	1
7	Notch	1
8	Temperature Control Knob	1

Table 3.6c

3.7 LCD Touchscreens

The LCD touchscreen for the grill will be the user's primary way of interacting with the grill while standing at the grill. The mobile application will work as a way of extending the capabilities of the touchscreen when the user needs to leave to take care of something else while the grill is doing the cooking. The touchscreen will be the way the user gets the cooking process started as they will be able to select what it is they are cooking and ensure that the target food temperatures the grill will be bringing the food up to are at the level desired.

For the purposes of the grill we will need a touchscreen that is somewhat resistant to temperature changes as it could be used indoor or outdoors. The touchscreen will need to be housed in an enclosure that can protect the circuitry from getting wet or damaged. Even though the touchscreen doesn't necessarily need to be waterproof, it needs to be able to withstand some degree of abuse from anything that may fall onto it from the cooking process. It will be important that the user regularly maintains the cleanliness of the touchscreen to ensure it continues to work properly.

Since we will not be building our display from scratch we will need to obtain one that comes already built and can be customized. There are touchscreens that sense pressure from your finger and touchscreens that can detect simply that your finger is on the screen. It seems to be easier for the user to use a touchscreen that can detect a finger instead of just pressure, however the budget for our prototype may limit the touchscreen that we are able to use.

A good solution for our touchscreen needs would most likely be the uLCD-70DT by 4D Systems. They offer a variety of different sized touch screens with the largest that would accommodate our budget being seven inches. This display is a thin film transformer screen (TFT touch screen) and works by using transistors to determine what location on the screen is being selected. The screen has a DIABLO16 graphics processor and 800x480 resolution with 65K colors. The screen should be more than enough to satisfy the needs of our project.

The touchscreen will also need to be programmed to display various options on the display. the uLCD-70DT comes with a programming software to assist with creating the screen environment. The coding for the LCD screen is done in a program called ViSi and the layout can be created and uploaded to the board. The microcontroller that will be running the entire project will be able to communicate with the LCD and determine when something is being pressed or the content on the screen needs to be updated. The LCD will constantly show the temperature of the three locations being measured so the user always has an accurate and up to date reading. When the user is not near the grill, these same temperature readings will be available from the mobile application.

3.8 Wifi/Bluetooth Communication

Since an app is being developed, including some type of wireless connection will enhance user experience. Adding Bluetooth as a key feature will allow the app to connect to other Bluetooth enable devices. The Microcontroller device will include a chip that allows the Bluetooth connection to happen. Android has a Bluetooth API that provide the functions needed. Although this way of wireless connection is great, there are a lot of well known consequence as well such as how much battery energy is used and no-to-little security is provided. According to IEEE 802.11, Bluetooth allows the device to be up to 200 meters away from other devices on a Bluetooth 4.0 device. Although the maximum distance is 200 meters, the device plays a key part on the maximum distance. The app will also use Wi-Fi to connect wireless. Wi-Fi offers more security since it relies on WPA2 security and it will just need to have wireless adaptor set to the microcontroller. Wi-Fi is also faster than Bluetooth technology.

There are many modules that allow Bluetooth capabilities that are compatible with most microcontroller, especially for Arduino devices. Ideally the goal is to get a module that allows the user to be as far from it as possible. Some of the modules that work are BlueSMiRF, HC-06 RS232 TTL, BLE Mini, ITEAD BT and BlueFruit EZ-Link. BLE Mini and BlueSMiRF allows a really good maximum distance range. Since BlueSMiRF has more tutorials, and as result, it will be the module that is used.

Microcontroller Module	Price	Max Distance (meters)
BlueSMiRF	\$24.95	60
HC-06 RS232 TTL	\$9.99	10
BLE Mini	\$24.95	50
ITEAD BT	\$13.50	10
BlueFruit EZ-Link	\$22.50	10

Figure 3.8a

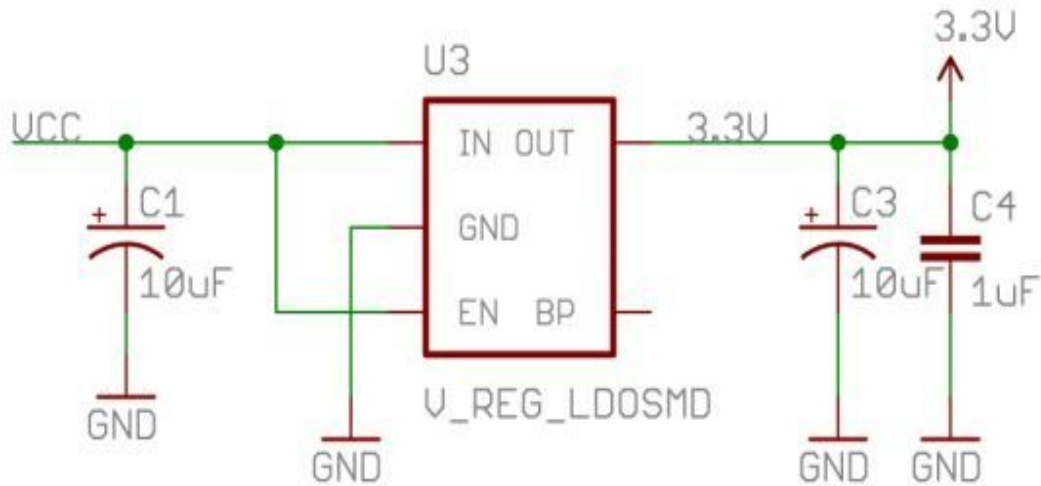

Figure 3.8b

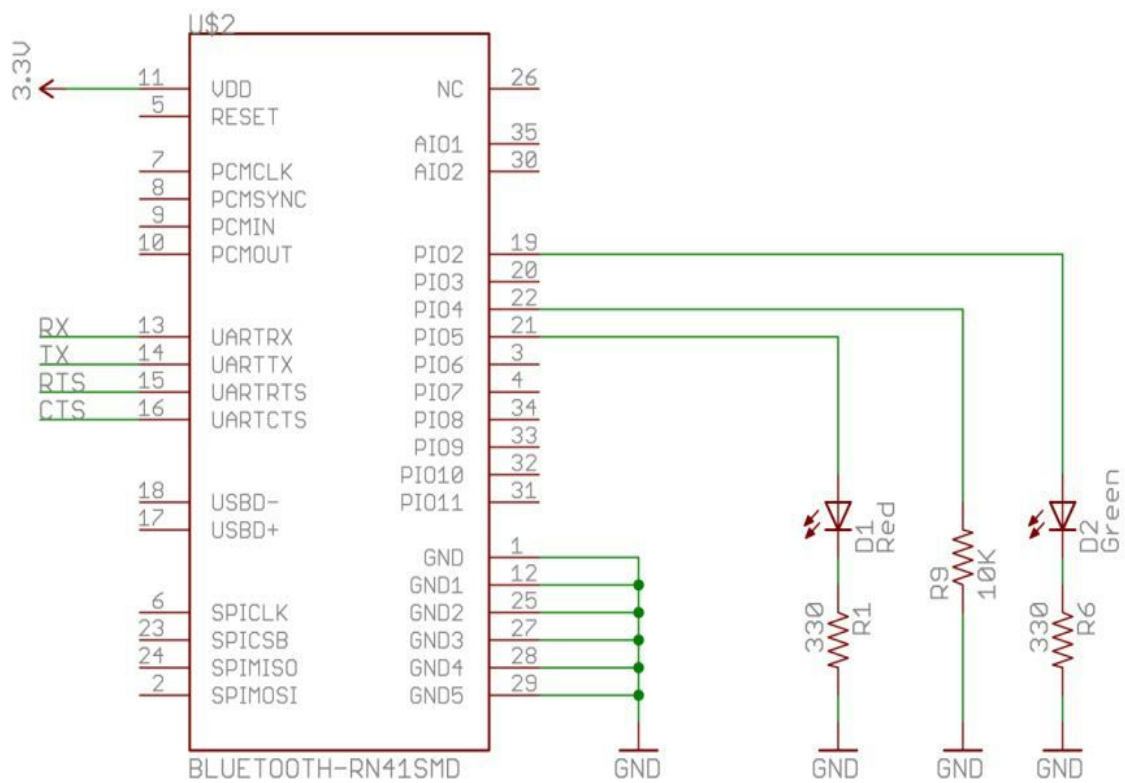

Figure 3.8c

There is also the option of getting a module that allows both Bluetooth and Wi-Fi capabilities. TiWi5 and TiWi-BLE are two options that allows both type of connections.

3.9 Android Application Development

Although the mobile app can be seen as a minor feature, there are several goals that the app will target. The main goal is the ability to see a visual of all three readings from the temperature sensors and having a set timers for the users. Another goal of the app is to be able to help the user be able to determine what temperatures should be used. The combination of these goals will allow a user to be a long distance away from the grill.

There will be both a user and an administrator. The user will be able to accomplish all the goals mentioned earlier. The administrator will be the only one setup up all features and program or delete pre-saved temperatures readings for future purposes. Figure 3.9a is a user diagram depicting the actors that are involved. The microcontroller plays an important part for the app. It is uncertain if an administrator will be needed since it might be too cumbersome. Figure 3.9b is a class diagram and depicts the main classes and their responsibilities. A specific class will be handle everything relating to food such as what the food is and how they want it cooked. As of now, it does not look necessary to use inheritance. Figure 3.9c is a sequence diagram, which shows how each class is going to interact with each other.

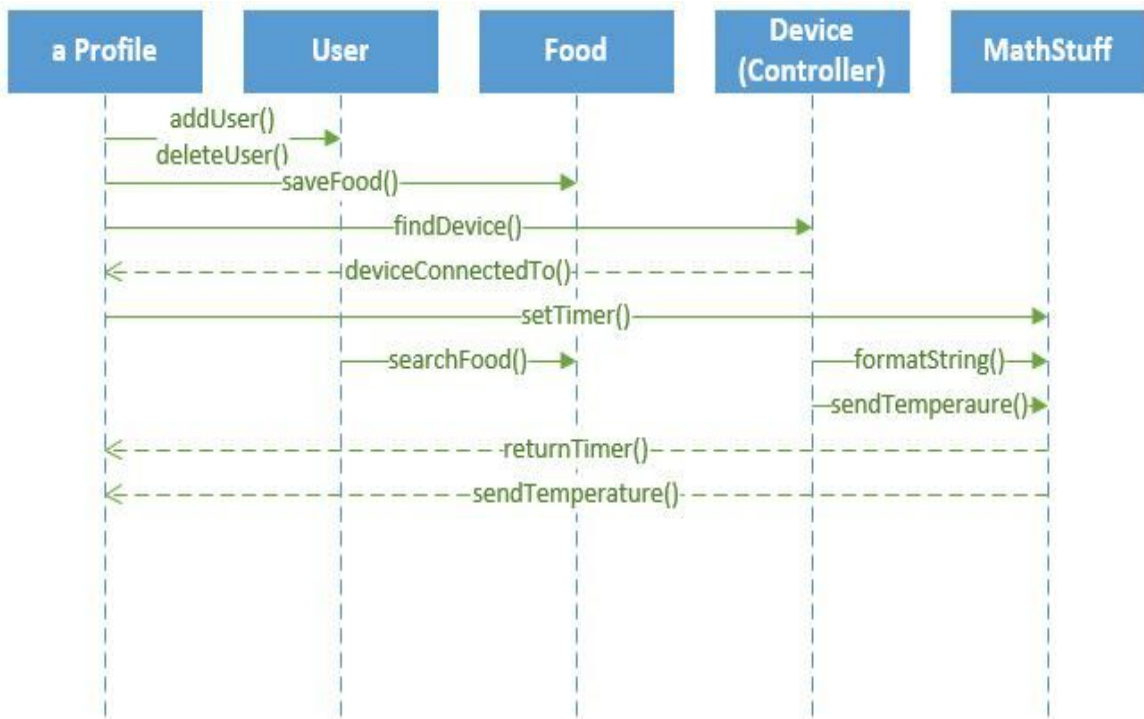

Figure 3.9c

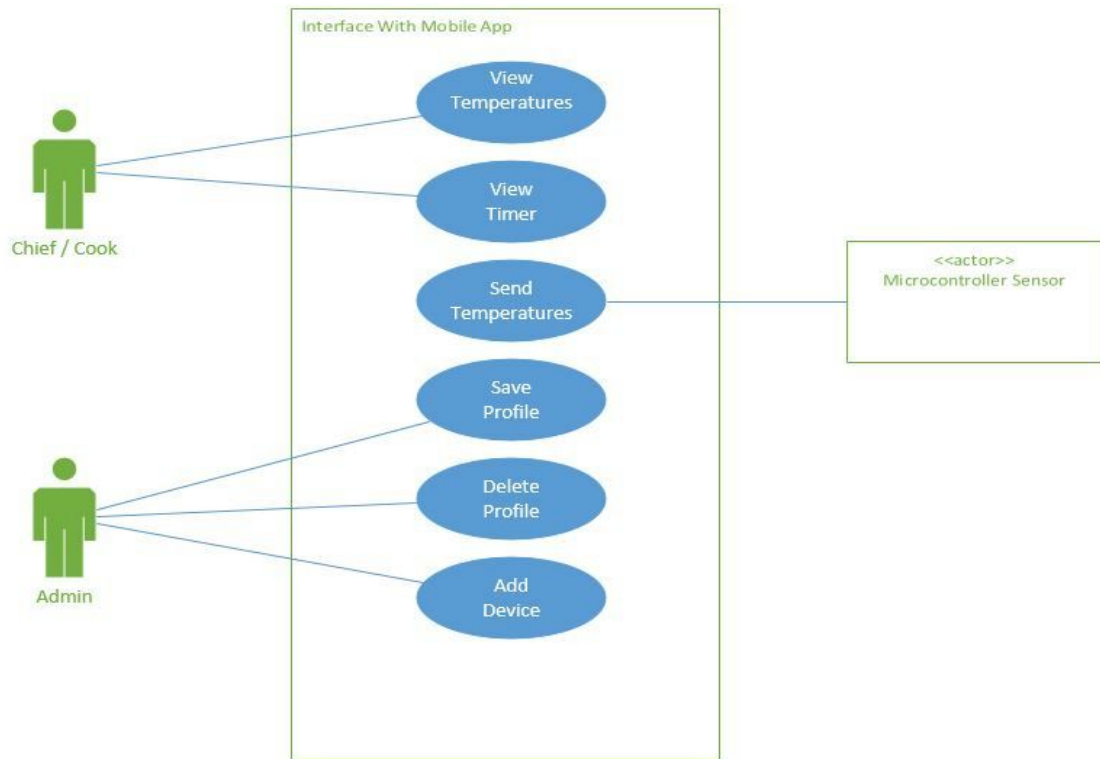

Figure 3.9a



Figure 3.9b

There will most likely be three activity layouts. There will be the home screen. The home screen, which will contain the option of creating the user profile and logging in. This will either take you the main screen or the settings screen.



Figure 3.9d

The main screen will have all the important temperature sensor reading and tell you when it is is either time to flip your food, if your food is cooked like you wanted, or did you burn the food. The third option should never be the case, but for safety measures, an alarm will activate.

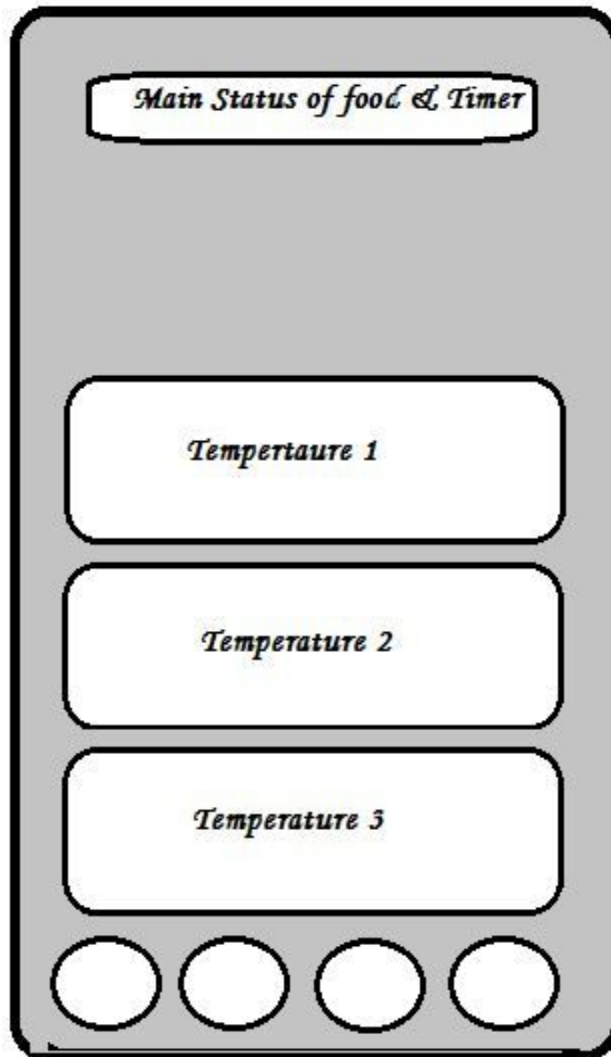

Figure 3.9e

The settings screen, will just have basic signup information and information relevant for the user profiles. The App will receive the temperature readings from the sensors via Bluetooth or Wi-Fi as inputs. The temperatures will be displayed on as outputs and the user will have an option to display them in either Fahrenheit or Celsius. A few inputs will have to be stored overtime such as the User Names, Passwords, and a few other relevant information. There will be no special calculations needed, except converting Celsius to Fahrenheit.

The most common question when it comes to creating an app for a phone is, what platform to code for? There are basically three options: Android, IOS, and Windows. It's fair to leave Windows out of the options due to the fact Windows is still an unpopular platform among Windows. If time was not so crucial, both Android and IOS would be an options. There are many pros and cons on why to use one platform instead of the other. The chances of Android User buying an

app is relatively low compared to an Apple User. Since the app would be a feature that is for the Smart Grill, the cost of the app can just be added to the Grill instead. IOS uses Objective- C as its programming language, which is too difficult to learn due to its similarities with C. Android using a different language than IOS; android takes advantage of using Java. Java is easy to learn and will be extremely beneficial skill to learn. The group is more familiar with Java, so as a result the app will be done for Android. The two main developing software for Android are Eclipse and Android Studio. Eclipse was the dominate IDE for Android before the release of Android Studio. Both IDE are documented and is easy to find help online. There isn't a clear winner between the two, but Android Studio help a little bit more with Code Completion, simpler, and also has a nice use interface to look at. There also have been indications from Android Developer Blog that Eclipse will no longer be supported to develop for Android. In conclusion, Android Studio will be the IDE used to develop the app.

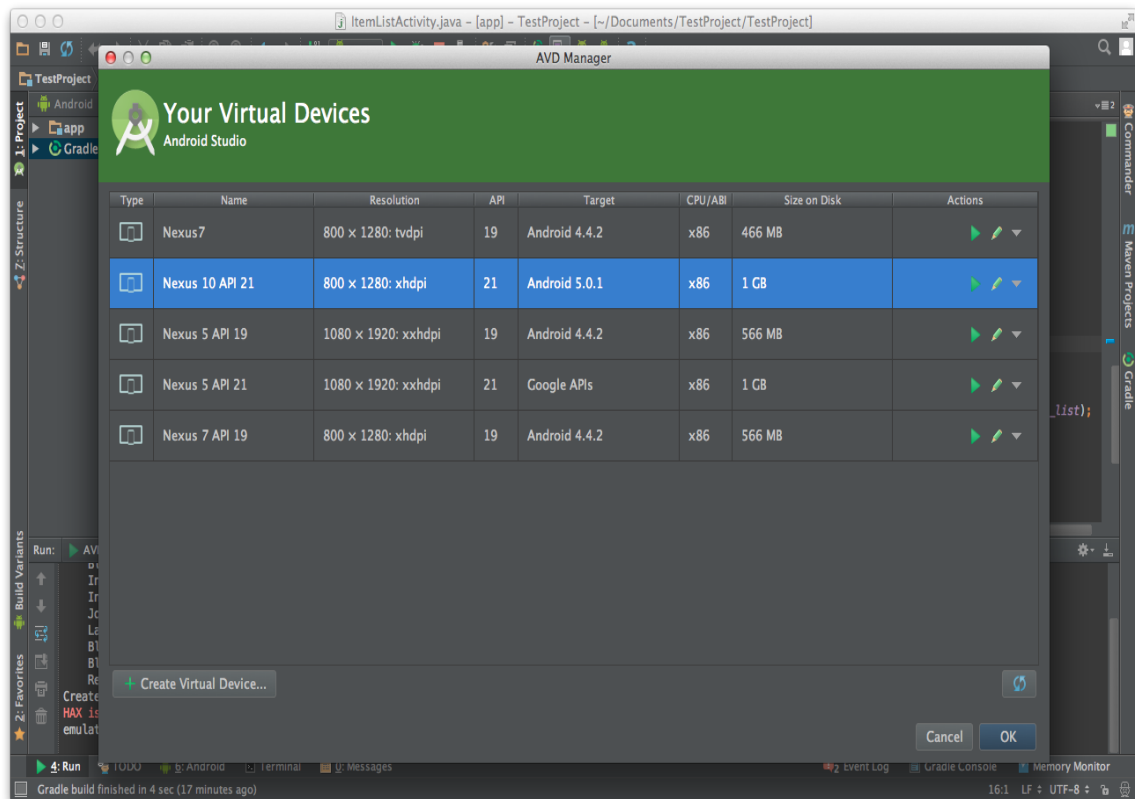

Figure 3.9f

3.10 Database

It is extremely inefficient to save a profile to a text file, so a database allows for scalability. Two of the most popular cloud database are Parse and Firebase. Parse will be the databased used to save the profiles. Both databases has a free version. Figure 3.10a show the prices for Firebase and 3.10b shows the prices for Parse

Database	Parse	Firebase
Email Verification	X	X
Current User	X	X
Anonymous User	X	
Secured Information	X	X
Password Reset	X	?
Twitter Login	X	X
Facebook Login	X	X
Google Login		X
Push Notification	X	
Documentation	X	X
Automatically Scaling	?	X
Works Offline	X	X

Figure 3.10c

	Free	Spark	Candle	Bonfire	Blaze	Inferno
	\$0 forever	\$5 per month	\$49 per month	\$149 per month	\$449 per month	\$1,499 per month
REALTIME DATABASE						
Connections	100	100	UNLIMITED*	UNLIMITED*	UNLIMITED*	UNLIMITED*
Storage	1 GB	1 GB	10 GB	30 GB	100 GB	300 GB
Transfer	10 GB	10 GB	50 GB	150 GB	500 GB	1.5 TB
Private Backups	✗	✗	✗	✓	✓	✓
AUTHENTICATION						
Users	UNLIMITED	UNLIMITED	UNLIMITED	UNLIMITED	UNLIMITED	UNLIMITED
HOSTING						
Storage	1 GB	1 GB	10 GB	10 GB	10 GB	10 GB
Transfer	100 GB	100 GB	1 TB	1 TB	1 TB	1 TB
Custom Domain	✗	✓	✓	✓	✓	✓
	Sign	Purchase	Purchase	Purchase	Purchase	Purchase

Figure 3.10a

Core

Store data and build your app

30 requests per second | 1 background job

\$100/10 requests, pro-rated by the hour

EXTRAS

- File Storage: 20GB (\$0.03/GB extra)
- Database Storage: 20GB (\$200/20GB extra)
- File Transfer: 2TB (\$0.10/GB extra)

MONTHLY COST Free

Push

Notify and re-engage your users

1,000,000 unique recipients

\$0.05/1000 extra recipients

EXTRAS

- A/B Testing: Unlimited
- Custom Segmentation: Unlimited
- Scheduling: Unlimited

MONTHLY COST Free

Analytics

Track events and improve your app

Unlimited event tracking

EXTRAS

- Custom Events: Unlimited
- Instant Breakdowns: Unlimited
- Advanced Reports: Unlimited

MONTHLY COST Free

Figure 3.10b

Although there's no clear winner between Parse and Firebase, the app will be using Parse. Push Notification and the amount of free resources that helps learn how to Parse is the main reason. Also, not being too familiar with JSON, which

Firestore uses lead to a small advantage to Parse. Using Parse will now allow users to be able to login in with one of the available social media listed on the diagram. Users will not need to worry about the app automatically signing them out when they close the app. It is uncertain if the option of using Anonymous will enable.

3.11 Microcontroller

One of the most important components to this project is the microcontroller. There are several factors that need to be considered when choosing the microcontroller. Some of the factors are cost, power-consumption, RAM, amount of documentation, form factor, number of pins, programming language and architecture type. Since most of the group does not have a huge amount of experience with embedded systems, the importance of finding documentation is weighed more than everything else.

There are many different popular options such as Texas Instruments' MSP430 and BeagleBone, Arduino Mega, Arduino Uno, Arduino Nano and the Raspberry Pi. The Raspberry Pi is not actually a microcontroller and offers a lot of different features. One of the favorite microcontrollers is the MSP430 Launchpad. Although there are many great features and has an extremely affordable price, the amount of memory and other features are not enough. Both the Raspberry Pi and Texas Instruments' BeagleBone Black use Linux and afford a great amount of features, but the prices are relatively expensive based on how they would be used. Since Bluetooth capabilities are needed, the microcontroller needs to be able to connect to the Bluetooth module. Arduino has great documentation and makes it simple for those with little experience the ability to learn how to use it quickly.

Many of the major microcontrollers listed have clones on the market. Most of the clones often have more features, pins, and/or can be bought at a lower price. These clones are legal and often have more documentation, since the documentation from the known brand can be used. One clone version is the Funduino Uno, which is a clone of the Arduino Uno. There are essentially no differences between the Funduino Uno and Arduino Uno except for the prices.







							
Board:	Arduino Uno	Arduino Due	Arduino Yun	MintDuino	Galileo	Raspberry Pi	BeagleBone Black
Price:	\$34.99 \$29.99	\$49.99	\$68.99	\$24.99	\$84.99	\$39.99	\$59.99
Starter Kit:	\$64.99						\$119.99
Quick summary:	Current "official" Arduino USB board, driverless USB-to-serial, auto power switching	Newest Arduino based on a powerful ARM Processor. Packs many new features in a Mega sized form factor.	The power of and ease of use of Linux with the connectivity of Arduino!	An Arduino Compatible board you build yourself on a breadboard.	An x86 based Linux board with Arduino shield and IDE compatibility.	Single board Linux computer with video processing and GPIO ports	Next-gen, ARM-based, hardware hacker-focused Linux board; Programmability of RasPi + Arduino Connectivity.
Special Features:	Onboard USB controller	Android ADK Support, 2 12bit ADC / DAC, USB Host, CAN BUS support	An Arduino with an Atheros processor runs Linino. Includes onboard Ethernet, WiFi, and USB host.	An Arduino compatible that you build yourself!	x86 based processor, Arduino IDE & shield compatibility, onboard Ethernet, USB Host, Mini PCIe for expansion.	HD Capable Video Processor, HDMI and Composite Outputs, Onboard Ethernet	Onboard USB Host and Ethernet, 2GB onboard storage, HDMI output
Processor:	ATmega328	32-bit SAM3X8E ARM Cortex-M3	Atheros AR9331 / ATmega32u4	ATmega328	Intel® Quark SoC X1000	ARM1176JZF-S	Sitara AM3359A ARM Cortex-A8
Processor Speed:	16 MHz	84 MHz	400 MHz / 16 MHz	16 MHz	400 MHz	700 MHz	1 GHz
Analog Pins:	6	12	12	6	6	None (no onboard ADC)	7
Digital Pins:	14 (6 PWM)	54 (12 PWM)	20 (7 PWM)	14 (6 PWM)	14 (6 PWM)	8 Digital GPIO	65 GPIO (8 PWM)
Memory:	SRAM 2KB - EEPROM 1KB	SRAM - 96 KB	RAM 64MB DDR2, 32MB Flash (Atheros). 32KB Flash, 2.5KB SRAM (Atmel)	SRAM 2KB - EEPROM 1KB	8MB Flash, 512KB SRAM, 256MB DRAM	RAM 512MB	DRAM 512MB DDR3L, eMMC 2GB
Programming Language:	Arduino / C Variant	Arduino / C Variant	OpenWRT / Arduino IDE	Arduino / C Variant	Arduino IDE (Capable of running Linux distros from MicroSD)	Any language supported by a compatible Linux distribution (such as Raspbian or Occidentalis)*	Any language supported by a compatible Linux distribution (Debian, Ubuntu, Android, etc.).* Pre-loaded with Debian*
Programmer:	USB, ISP	USB, ISP	USB, SSH	Requires programmer like FTDI Friend	USB, SSH	You can run any of the Linux-compatible text editors and IDEs right on the Raspberry Pi.	Runs any of the Linux-compatible text editors and IDEs; supports Web IDE and BoneScript
Expansion:	Shield & Accessories	Shield & Accessories	Shield & Accessories	Shield & Accessories	Shield & Accessories	Breakout boards such as the Pi Plate and Pi Cobbler.	Capes
Assembled or Kit:	Assembled	Assembled	Assembled	Kit	Assembled	Assembled	Assembled

Figure 3.11a

4 Design Plan

This section highlights the design plan for our smart grill project. The smart grill is an electric grill with the ability to cook a desired food option on its own with minimal help from the user. To implement this design, we have come up with this plan on how we will configure our grill to work properly. In later sections, details on how the prototype will be fabricated and tested will be introduced. The grill design is composed of a few components that will need to communicate seamlessly for everything to work correctly.

The main component of course is the grill housing which will be where the actual cooking takes place. Here there will be several temperature sensors reading the temperature of the grill, meat and burners. This data will then be picked up by the microcontroller which will be programmed to make decisions on when to heat the burners or turn them off. The microcontroller will also constantly update the information from the temperature sensors to the LCD touchscreen and the mobile application. The microcontroller will also keep track of the estimated time remaining for the food to finish cooking and will display this on the LCD touchscreen as well as the mobile application.

For the electric burners, which will require a higher voltage than the LCD touch screen, microcontroller, and WiFi/Bluetooth module, the microcontroller will regulate when this voltage is applied to the burners to make them heat up. The details of all of the design plans and how everything will actually be implemented will be outlined in this section.

4.1 Temperature Sensing

The temperature sensors are an essential part of the grill design to ensure that feedback is constantly being fed to the microcontroller. This will allow it to make important decisions on doneness and being able to alert the user of the current grill status. The ambient, food, and burner temperature sensors that are used for this grill, will be a thermistor like the ones discussed in Section 3.3.2 on thermistors. A challenge to the temperature sensing will be ensuring that they are all calibrated as equally as possible. Since there are slight variations between resistors, there will be some error in measuring which will be negligible if the difference between the sensors is small enough. The temperature sensing will give the microcontroller analog data that it can use to turn the burner power supply on and off. While on, the burner supply will heat the burners causing an increase in temperature across all three sensors. This will be a feedback loop to the microcontroller to determine when to continue heating or to alert the user that the food has finished cooking. Figure 4.1a on the following page shows a flowchart of the feedback process that will occur between the microcontroller and the temperature sensors.

Figure 4.1a

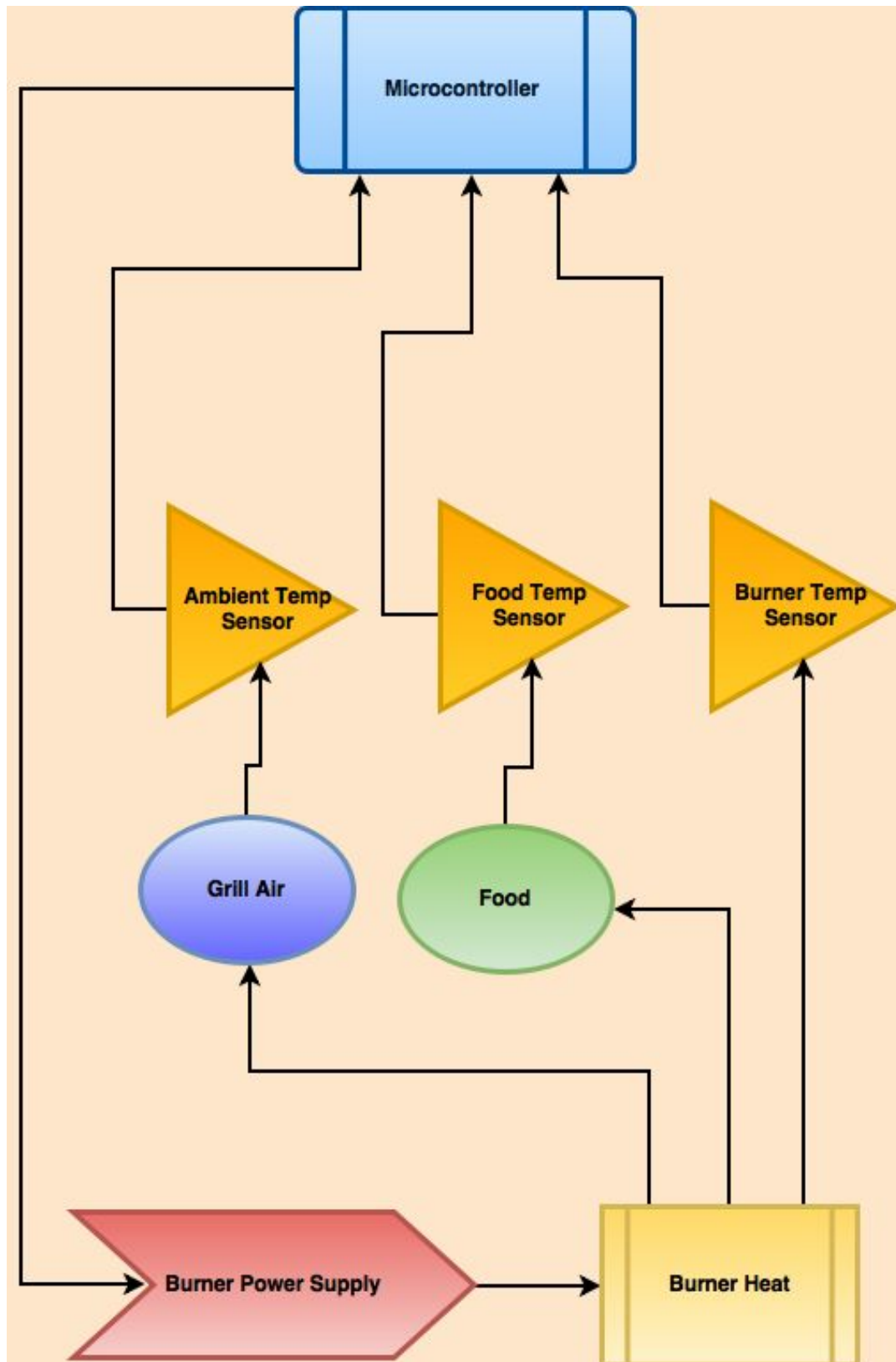

As seen from the flow diagram, the driving piece behind the whole temperature sensing system is the microcontroller. The burner power supply will need to supply a higher voltage and current to the burners than can be supplied from the microcontroller. Therefore, the signal from the microcontroller will only be used as a messenger to relay information to the supply to increase the burner heat. The supply will be able to be regulated based on the need for heat read by the three temperature sensors. As the burners heat up it will directly affect the burner temperature sensor as it will be attached to the burner itself. The food and ambient temperature sensors will be indirectly changed from the burner heat through the food or the air inside of the grill. The specifics of these temperature sensors will be discussed later in this section.

These temperature sensors will need to be plugged into an analog input on the microcontroller as the input voltage on the pin will vary as resistance changes due to the temperature variations. The temperature sensors typically come with a 3/32" audio connector at the end so an input jack for this will need to be mounted to the enclosure housing the microcontroller and the LCD touch screen. The enclosure housing will have three separate input jacks labeled for the three temperature sensors that will be used so the user can connect them correctly.

Most of these temperature sensor datasheets will give you the resistance value at 25°C and from here you are able to determine the second permanent resistor in the voltage divider circuit as well as how the voltage on the analog pin will change as temperature changes. The coding for the temperature sensors will involve writing a code that can convert the voltage into a temperature and will take some tweaking and calibration to ensure the write temperature is being reached. As mentioned earlier in the research section on temperature sensors, since we are using the thermistors in a voltage divider circuit, the temperature and voltage changes should be linear. Therefore, as long as the resistance of the thermistor is known at a given value it should lower linearly as temperature on the grill is increased.

4.1.1 Ambient Temperature Sensor

The purpose of the ambient temperature sensor is to measure the air temperature inside of the grill. Many grills have built in mechanical thermostats like the ones discussed in Section 3.3.1 on thermostats, however this will not be practical for this project as the temperature needs to be electrical data that can be read by the microcontroller, not a mechanical dial displaying a temperature. This temperature reading will only measure the air surrounding the meat and will not be able to indicate that the food is finished cooking. However, this measurement can assist with the determination on if the cooking environment is at an acceptable temperature for the food to cook properly. On traditional grills, this is used as an estimate of the food temperature, but of course it is

recommended to measure the actual temperature of the food as well and not just go by the ambient temperature.

As will be discussed later in the project documentation, a lot of trial and error will need to be done to determine how the ambient temperature can give valuable information to alter the burner temperature as the food will most likely be about 50°F cooler than the actual food. Calibration of the temperature sensors will also play a critical role in ensuring that they are all measuring accurately.

4.1.2 Food Temperature Sensor

The temperature sensor for the food is one of the most crucial components to the entire design. Food safety and the prevention of foodborne illnesses typically starts with having food cooked to the proper temperature to kill all potentially harmful bacteria. When the user wants to cook something, the desired food option will need to be selected on the LCD touchscreen. From here, settings for food cooking temperature will appear and the user will be able to modify them if they see a need to. The user will be prompted to insert the temperature probe into the center of whatever food they are cooking. More details on the LCD touchscreen design and interface will be discussed in Section 4.4 on the “LCD Touch Screen Interface”.

As discussed previously, the temperature sensor will constantly monitor the food and display a real time temperature on the mobile application and on the touch screen. Based on average cooking time for whatever food item is being cooked and the current temperature of the meat, an estimated time needed for cooking will be displayed on the touch screen and mobile application as well.

For certain meats such as a steak, the user would have the option to cook the food to a desired doneness such as well-done, medium-well, medium, medium-rare, and rare. For these cases, cooking temperature will vary as the meat will not have to cook as long for rare steak as it would for well-done. All of the standard temperature values for the doneness of these meats will be pre-programmed so the user can simply select what they are cooking and how they would like it cooked.

4.1.3 Burner Temperature Sensor

As with the ambient temperature sensor, the burner sensor will be measuring what is going on in the grill environment instead of the actual food being prepared. The burner temperature sensor will be subjected to the highest temperatures as it will need to be attached directly to the burner to get an accurate reading. In order to successfully attach the temperature sensor brackets will most likely need to be put in place on the edge of the grill so that it is held

against the burners. This temperature information could be valuable for the grill to regulate the burners.

Some food needs to cook at a lower temperature for longer instead of a higher temperature for a shorter period of time. The burner temperature sensor will essentially keep the grill in balance and ensure the meat is being cooked instead of just burned. If too much heat is applied too quickly, it will just burn on the outside instead of cooking thoroughly through.

Setting maximum temperatures for the burner will require some trial and error for different meats to see what would be acceptable and what would be too hot. Another important aspect to the burner temperature sensor is that it will allow the grill to preheat to a set temperature even before the user adds food to the grill. If the user is first starting the grill up and the burners are cold, food wouldn't be able to be added right away. Once the burner temperature senses that the burners are at the appropriate temperature to begin cooking, the user will be notified on the LCD touchscreen and through the mobile application.

Figure 4.1.3a on the following page displays how all three of these temperature sensors will be configured using an ATmega328 microcontroller as an example. Regardless of the microcontroller being utilized, all of the temperature sensors will need to be attached to analog input pins. The digital pins can only read input values equivalent to 1 and 0 while the analog pins can receive a large variety of inputs for applications like this. Digital pins would not work for temperature sensing as they are not able to detect minute changes in resistance like we will need for this. They are more to determine if a signal is being received or not, instead of how strong the signal coming in actually is. For the schematic shown, PC0, PC1, and PC2 are three of the six analog pins available on this particular microcontroller.

The Vcc from the microcontroller will be attached to the positive lead for each of the thermistors. The negative lead for the thermistors will be attached to an invariable 10K Ω resistor that will also be attached to the ground pin on the microcontroller. This will create a voltage divider circuit between the thermistor and the resistor. In between these two are the nodes that will be connected to the analog input pins on the microcontroller. If necessary for better results, a unity gain buffer can be added in between this node and the analog input pin for the three temperature sensors. A unity gain buffer would keep too much power from being pulled from the Vcc and potentially make the temperature sensors more sensitive to changes.

Figure 4.1.3a

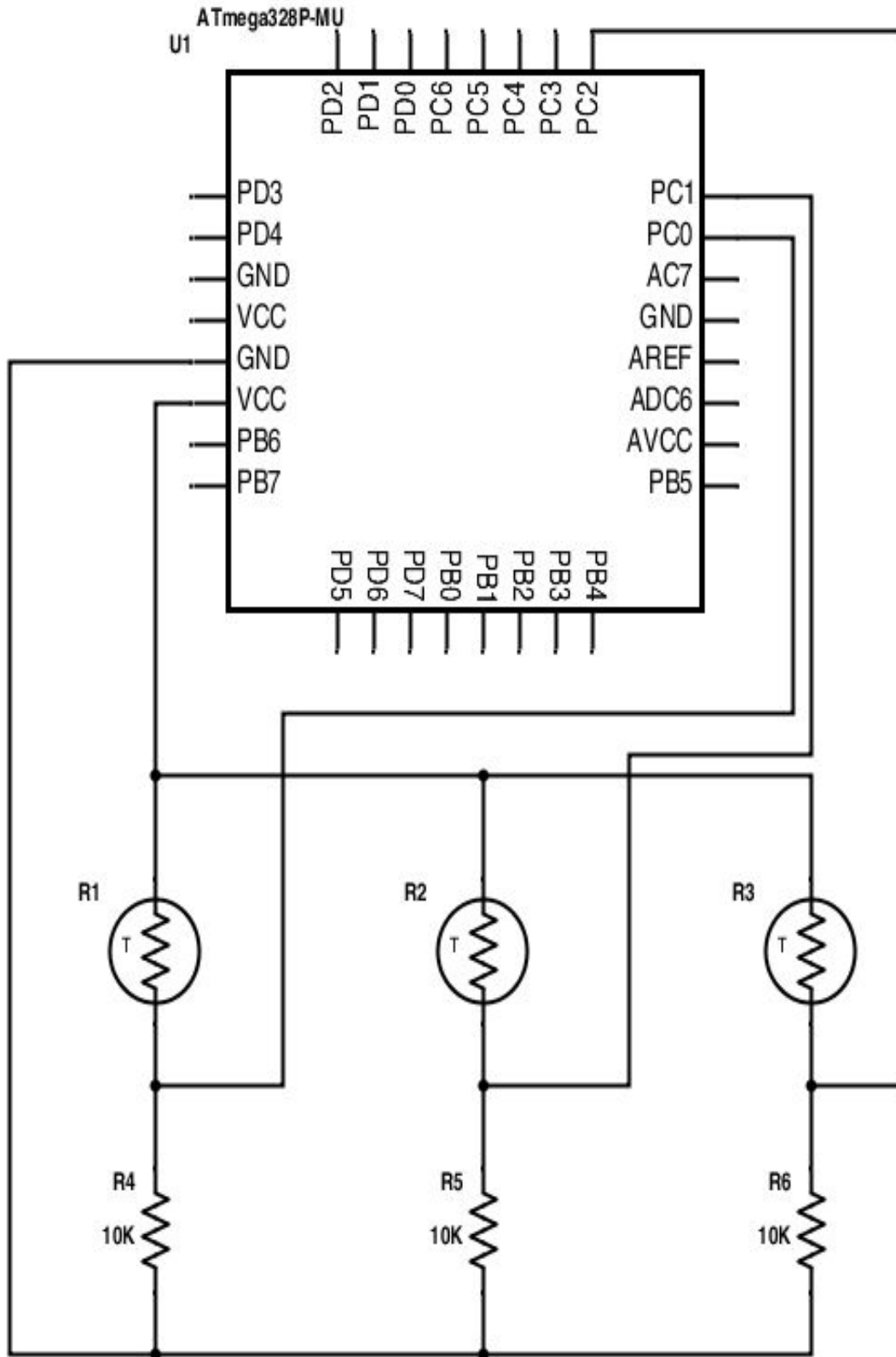

4.1.4 Temperature Sensor Placement

The placement of the Temperature sensor placement on the grill itself was extremely important. We needed three places so we put the burner temperature sensor directly on the burner, the ambient temperature sensor connected to the side of the grill on the inside and the Rotisserie/food temperature sensor on the back of the grill to be used manually. Figure 4.1.4a shows the Rotisserie/Food temperature sensor placement. Figure 4.1.4b shows the Burner and Ambient Temperature sensor placement.



Figure 4.1.4a



Figure 4.1.4b

4.4 LCD Touch Screen Interface

The LCD Touch Screen will be the user's primary way of interacting with the grill when not using the mobile application from a distance. The LCD Touch Screen will be mounted in an enclosure which also houses the microcontroller and input jacks for the three temperature sensors. This enclosure will be mounted to the side of the grill to avoid being subjected to extreme temperatures that could damage the interior components.

In order to program the touchscreen to provide an environment for the user to interact with a program called Workshop4 will be used. This program can be used to write code for the LCD touch screen so that all the displays are saved onto the memory of the touch screen. The microcontroller will be able to send commands to the LCD touch screen so that it displays the correct screen when needed. The microcontroller will also constantly communicate with the touch screen to display temperature readings and estimated time until the food is finished cooking.

When the grill is first powered on, no heat will be applied to the burners until the user selects the food they would like to cook. The user will have the option to choose between a hamburger, hotdog, chicken breast, or steak. This will be the main menu that will appear when the grill is first turned on. From this screen the only option will be to select one of the four foods or turn the grill back off from the power button at the top right hand corner. An example of the startup screen can be seen in Figure 4.4a below.

Figure 4.4a

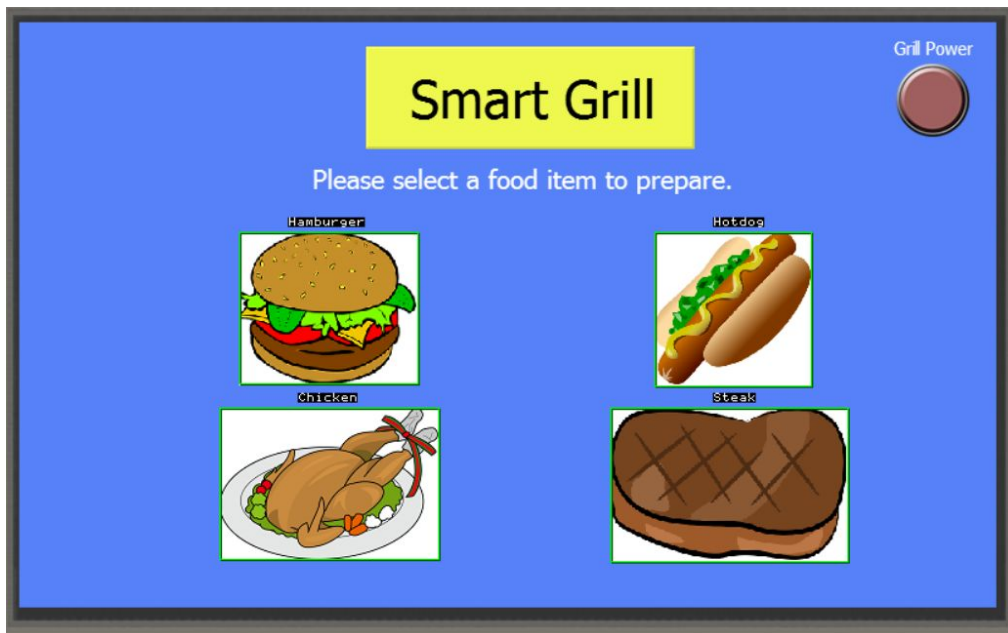

The screen size is large enough to add additional foods if necessary but since these are the most common food cooked on a grill and are easy to measure with a temperature sensor, they will be the main focus of our smart grill. Once again, the LCD Touch Screen will be the user's primary way of interacting with the grill when not using the mobile application from a distance. The LCD Touch Screen will be mounted in an enclosure which also houses the microcontroller and input jacks for the three temperature sensors. This enclosure will be mounted to the side of the grill to avoid being subjected to extreme temperatures that could damage the interior components.

In order to program the touchscreen to provide an environment for the user to interact with a program called Workshop4 will be used. This program can be used to write code for the LCD touch screen so that all the displays are saved onto the memory of the touch screen. The microcontroller will be able to send commands to the LCD touch screen so that it displays the correct screen when needed. The microcontroller will also constantly communicate with the touch

screen to display temperature readings and estimated time until the food is finished cooking.

When the grill is first powered on, no heat will be applied to the burners until the user selects the food they would like to cook. The user will have the option to choose between a hamburger, hotdog, chicken breast, or steak. This will be the main menu that will appear when the grill is first turned on. From this screen the only option will be to select one of the four foods or turn the grill back off from the power button at the top right hand corner. The LCD touch screen will offer a unique way for the user to interact with the grill. Even though the grill has some limitations as far as what the user can cook, it does offer the ability for custom cooking temperatures to be entered after the grill is preheated. If the user wants to cook something that is not offered in the programming they could pick the temperature they want to cook it to and place it on the grill. The only issue with this is that different foods cook heat up at different rates so the timer may not be completely accurate using this method. When cooking preprogrammed foods, the timer will display an estimated time until the food needs turned over or is finished cooking based on our trial and error testing for that specific size of food.

For the purpose of this example, we will choose the steak option. When the steak option is selected the preheating process will begin, this screen will show the user the current burner temperature and the estimated time remaining to reach that temperature. Both of these values will also be sent to the mobile application so the user can monitor it remotely if needed. The preheating screen example can be seen in Figure 4.4b.

Figure 4.4b

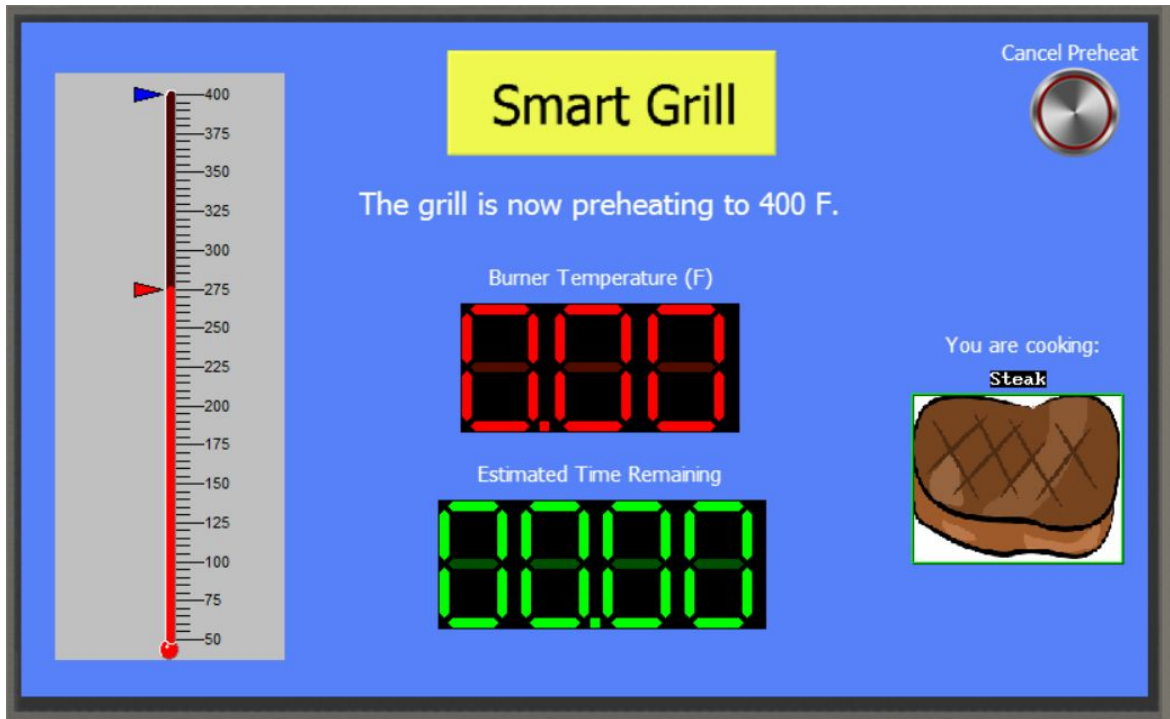

From the preheat screen, the user will see the temperature thermometer on the left. This gives a visual representation of the current temperature (represented by the red arrow) and the final preheat temperature (represented by the blue arrow). The exact temperature for the burner can be seen with the red digits and on the mobile application. The estimated time remaining for the preheat can be seen through the green digits below. On the right a reminder of what is going to be cooked can be seen. If the user has selected the wrong food option or they have decided they don't want to use the grill any more, the preheating process can be cancelled utilizing the button in the top right hand corner. This will send the user back to the main screen and stop the burner heating so the user can turn it off or select another food to cook.

Once the preheat process is completed, the user will be notified on the touchscreen and well as through a notification sent to the mobile application. This will bring up a screen as shown in Figure 4.4c below allowing the user to make additional selections regarding the cooking process of the steak.

Figure 4.4c

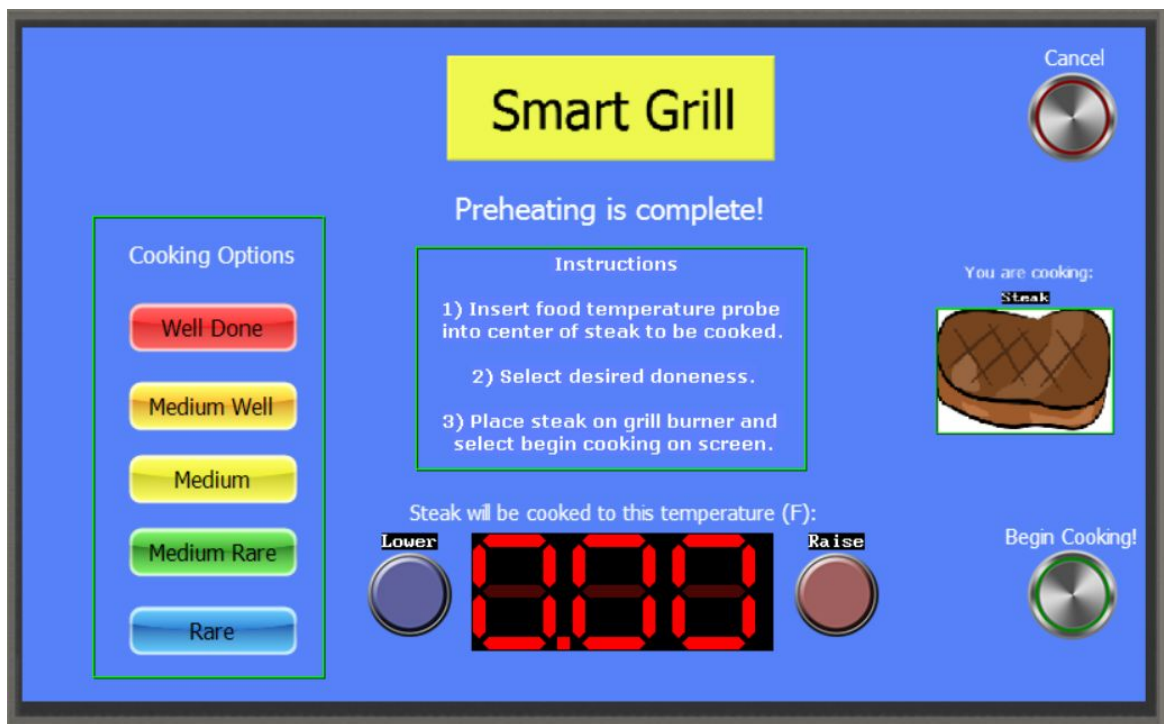

The instructions will be provided on screen that tell the user to insert the temperature probe into the center of the meat being cooked. The user will then need to choose a cooking option as far as doneness on the left. This ranges from well done to rare. Once a cooking doneness is selected, a pre-programmed temperature for the meat will be displayed on the LCD touch screen. For a medium steak, this will be based on the temperature that a steak is considered to be cooked to medium doneness. If the user decides they want their steak a little under or over cooked from the preset temperature, raise and lower buttons are available on the sides of the preset temperature display. These buttons will allow the user to toggle the temperature in increments of 5°F. Finally, once the user has decided on a cooking temperature that suits their taste, the steak can be placed on the grill burners and the begin cooking button can be pressed. By beginning cooking, the user is acknowledging that the meat is on the grill and a timer will begin counting down until the steak either needs attention or is finished. If at anytime the user decides they do not wish to use the grill anymore, the process can be cancelled by pressing the red button in the upper right hand corner. This will return the user back to the main page and the burners will begin to cool back down.

Once the cooking has begun, the LCD touch screen will change to the display seen in Figure 4.4d. Meanwhile, the mobile application will also display the estimated time until the steak needs attention or is finished, and it will also display the current temperature of the grill, steak, and burners.

Figure 4.4d

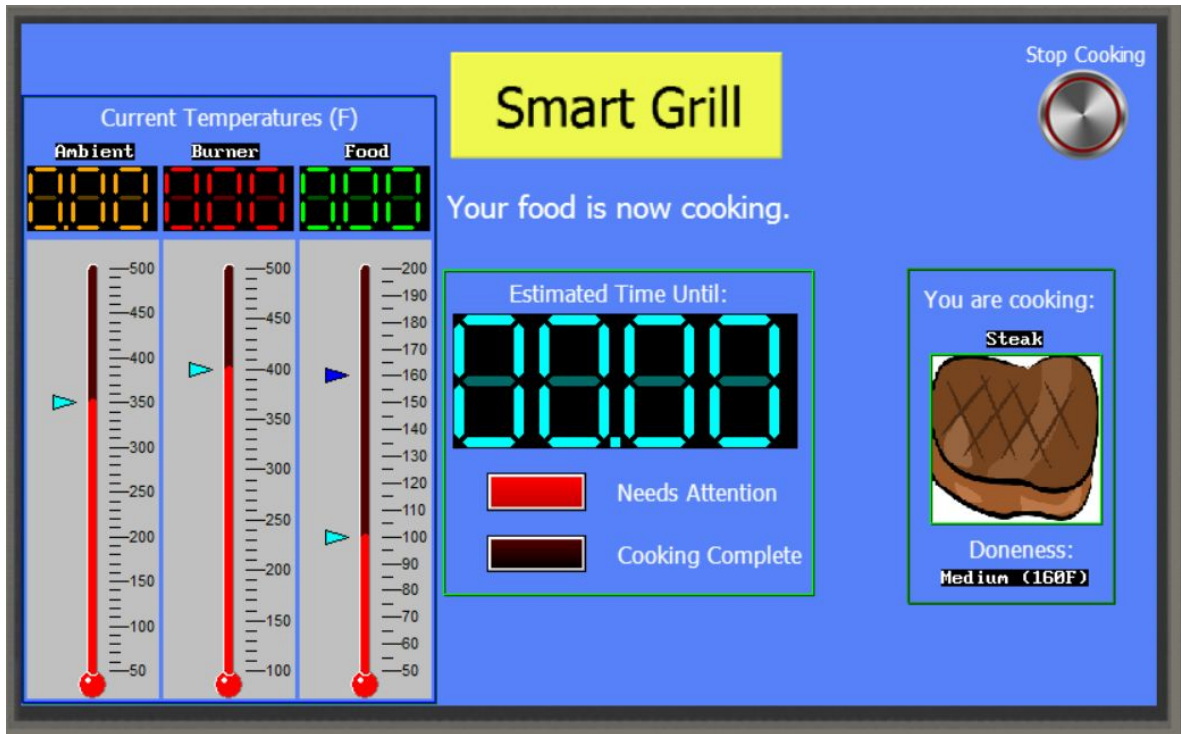

This screen will be similar to what will be displayed on the mobile application to convey similar information to the user from a distance. The left half of the screen will display real time temperature data coming from the three temperature probes. The orange digits will display the ambient air temperature inside of the grill. This isn't set to be at a specific value but gives information to the user to give them a general idea of how the cooking process is going.

As far as cooking goes, the ambient air temperature will be less useful to the microcontroller than the burner or food temperatures but could give useful information as far as the grill not being under normal conditions. For example, if the grill hood is left open, the warm air from the grill would be allowed to escape. This would create a large variance between the air and burner temperatures allowing the grill to notify the user that something is not right and needs to be corrected. Although when it comes to the actual cooking to the right temperature this value is not essential.

The burner temperature will be displayed in red digits and will remain generally around the same temperature that the grill was preheated to in the previous step. The food temperature sensor that is actually inserted into the piece of steak will have its value displayed by the green digits. The light blue arrow on the corresponding virtual thermometer will indicate to the user the current temperature the food is at. The dark blue arrow will indicate the temperature the food needs to reach before it is considered cooked to the desired doneness, in

this example 160°F. A reminder of what is being cooked can be seen to the right and the desired temperature will be displayed below it. If the user accidentally started the cooking process with the incorrect meat and/or doneness selected, they could opt to stop the cooking process by pressing the “Stop Cooking” button on the top right section of the LCD touch screen which would turn off the burners and return to the main screen. Selecting the correct settings from this point should be fairly quick as the preheat process will be a lot shorter as the burners will already be hot at that point.

Another important component of information that will be displayed on the screen is the time remaining from the blue digits in the center of the display. This will have a numerical count down until either the steak needs attention or is finished cooking. Two virtual LEDs are located below the countdown timer to indicate if the time currently being displayed is for the steak to be finished or that it needs attention. In the above example, the countdown is reaching the time that the steak will need attention. Once the timer hits zero, the user will be notified that their attention is needed via the mobile application and through the LCD. As seen in Figure 4.4e, a message will pop up on the bottom of the screen alerting the user of what needs to be done.

Figure 4.4e

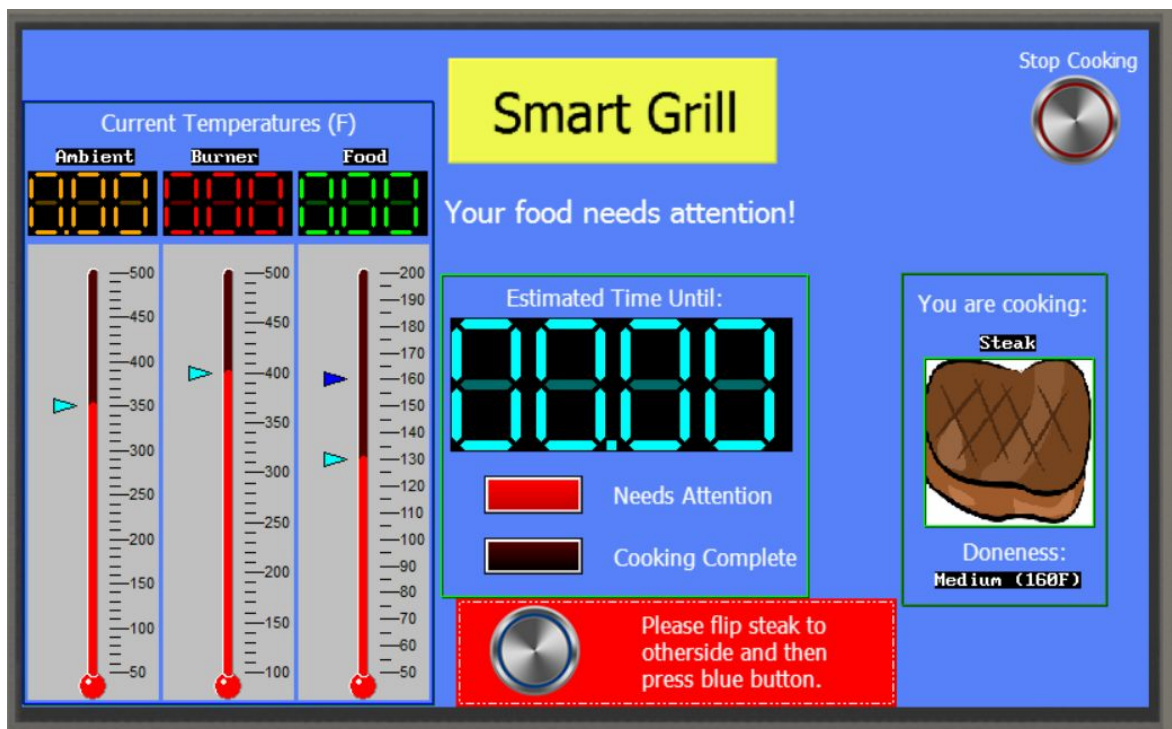

The user will then need to flip the steak to the overside to ensure both sides are cooked properly. Once the steak is flipped over it will be important that the user promptly acknowledges that they have rotated the steak by pressing the blue

button on the screen. This will remove the alert and allow the grill to begin counting down the time until the final cooking temperature is reached. As seen in Figure 4.4f, the LED corresponding to the “Cooking Complete” timer will illuminate and the user will be given an estimated time of when the steak, in this example, will reach 160°F.

Figure 4.4f

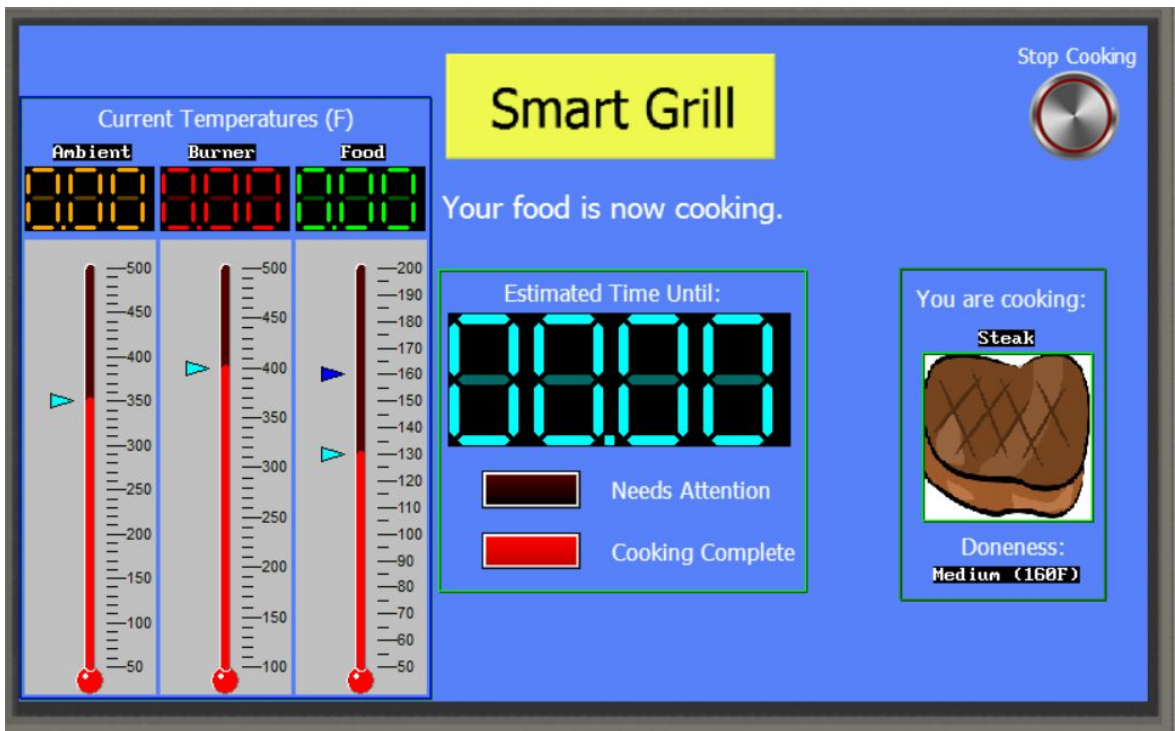

Once the second timer reaches the end of its countdown, the user will be notified that their food is finished cooking. A message similar to the one in the previous example will display at the bottom of the screen. This will alert the user to remove their food from the grill as it is finished cooking. The burners will turn off automatically as to not overcook the meat past the desired temperature. There will be a button next to this alert to acknowledge it and return the LCD touch screen back to the main menu. From here, the user can choose to turn the grill completely off by pressing the “Grill Power” button or they can choose to cook something else. A block diagram of the entire flow process of the LCD touch screen can be seen in Figure 4.4g below.

Figure 4.4g

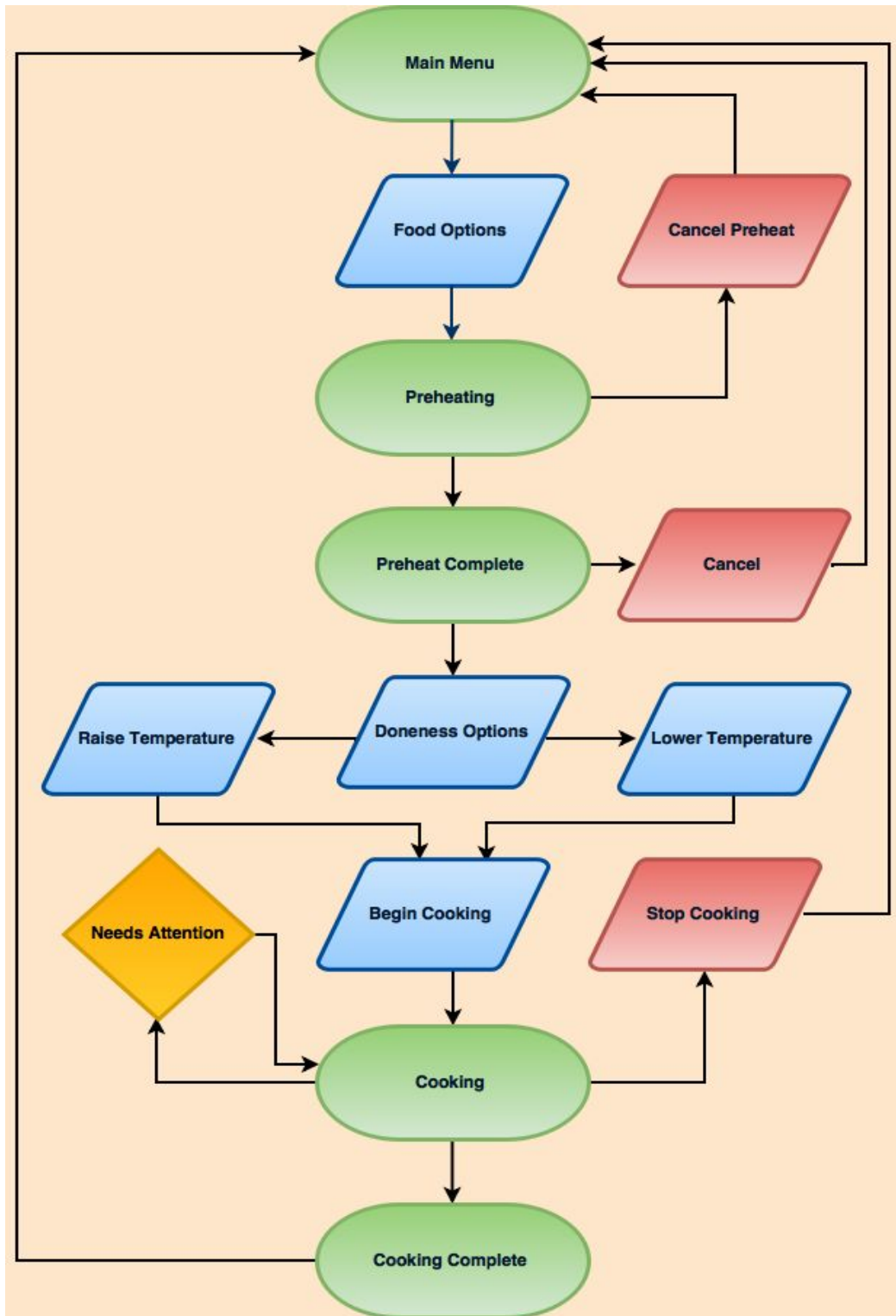

5 Power Management

5.1 Battery Design

Wrapping everything up on Smart Grill. by first looking at our high current and high voltage systems, of 15A and 120V respectively, together and our low current and low voltage, of 15A and 5V/12V respectively ,systems together. The burner that Smart Grill uses will have to be at 120V, therefore I focused my attention to how the burners actually accept power from the wall outlet and battery. In doing so I realized that the burners do not need 1800W AC power to operate under normal conditions. 1800W DC voltage and current will work the same due the burner being a resistive system and therefore is not affected by phase and frequency.

Powering an electric heating element, that in today's industry features ~250W to 2500W units is relatively simple, mainly because the grill chassis we are housing Smart Grill in already has a power outlet plug which hooks up directly to our 1800W burners. However, controlling our burners takes more understanding. In order to control an electric burner or element we had to understand how they actually work. For instance, voltages of 120V and currents of 10A to 15A that are needed to operate the electric burners in normal operating conditions. An electric grill heats up its food by generating intense radiant heat (with temperatures anywhere from 200 °F up to 700 °F) which powers on and off thus reenergizing its heat coils intermittently on a timer or if the temperature drops. Therefore, searing foods may not be possible as it requires intense heat for long durations of time, even if it's only for 2-3 seconds. The component that allows the re-energizing of the heat coils is the burner switch, also called an infinite heat switch. They are referred to infinite because they control heat from high to low and everywhere in between. The overall power block diagram can be seen below in Figure 5.0.

Figure 5.0

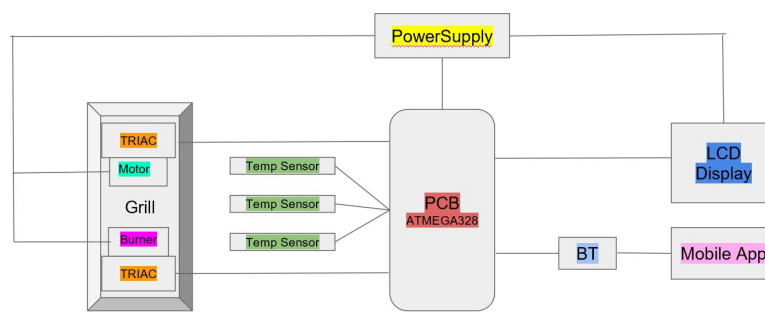

5.1 Battery Design

Electric burners are relatively flat so the food comes in direct contact with the burner heating the food evenly. When the food is placed on the electric burner, the burner conducts most of its energy (which is about 75%) directly into the pan rather than radiating it into the air as a gas flame would. Most of the heat is transferred by conduction. Conduction is the transfer of heat by direct contact between two or more surfaces. For our project this would obviously be direct contact between the food and the metal burners. When the food is placed on the burners thermal energy from the burners is transferred to the colder food as the neighboring molecules distribute kinetic energy to equalize the temperature. The constraints for the battery and burner system can be seen below in Figure 5.1.

Figure 5.1

Burner Specs

- ~11 Ohms
- rated @115VAC
- 1500W
- up to ~500F but regulated to 450F
- Food cooks 5F / 115s
- To increase ratio
 $V_s = IR \rightarrow 2500W?$



Burner Element

When designing the power system for smart grill we decided to break up each component of the power system and individually determine specifications for each one. When picking components for smart grill power design I use the following approach, research the industry's top ic solution but since there were so many from so many different companies I had to make an educated guess then compare the numbers of the top two components to reach the best solution for smart girl. I also try to leave as much headroom as possible when designing these components values. Working our way from the very start of the system is the wall outlet as well as the battery. Since the wall outlet terminals will not need to be designed due to it already being on the chassis I will begin the discussion for the power system with the battery. As with the majority of the components of the power system my main go when buying the battery was to get one that was inexpensive as well as durable. The battery will need to be at least 12V in which a step up converter will be used to reach 120V for the burners. It needs to be rechargeable and last 2 hours with all subsystems in normal operation. The battery will be connected to the burners and MCU and will be used when Smart

Grill has no access to a wall outlet. The Figure 5.1a and Table 5.1a show the exact battery our group decided to use for Smart Grill.

Figure 5.1a



Table 5.1a

BOM Part#	APX12-35
Voltage:	12 Volt
Capacity	35 Ah
Type	AGM Sealed Lead Acid Battery
Weight	22.5 lbs
Length	7 3/4"
Width	5 1/5"
Height	7"

The battery in Figure 5.1a below is the battery our group decided to chose and Table 5.1a are the specifications. It is a 12 volt 35 Ah AGM sealed lead acid battery that is rechargeable. The battery was built for rugged construction for outdoor or indoor use. The materials which make this battery have great

resistance to shock, vibration, chemicals and heat. The battery has a low self-discharge rate. It also has a dependable lifetime that can be expected under normal operating conditions. The battery will be hooked up via power MOSFETS to the step-up transformer for the burners as well as directly to the voltage inputs to the regulators for our motor and temperature sensors, which can be seen in Figure 5.1b on the purple wire. Breaking up the Smart Grill power design into subsystems, one subsystem is for the burners, one subsystem being the logic or MCU and the two different power sources able to optionally power the two subsystems. The Multisim schematics for the battery powered system is shown in Figure 5.1b the function of the battery should be exactly the same as the function of the wall outlet power supply in order for Smart Grill to operate under normal conditions.

Figure 5.1b

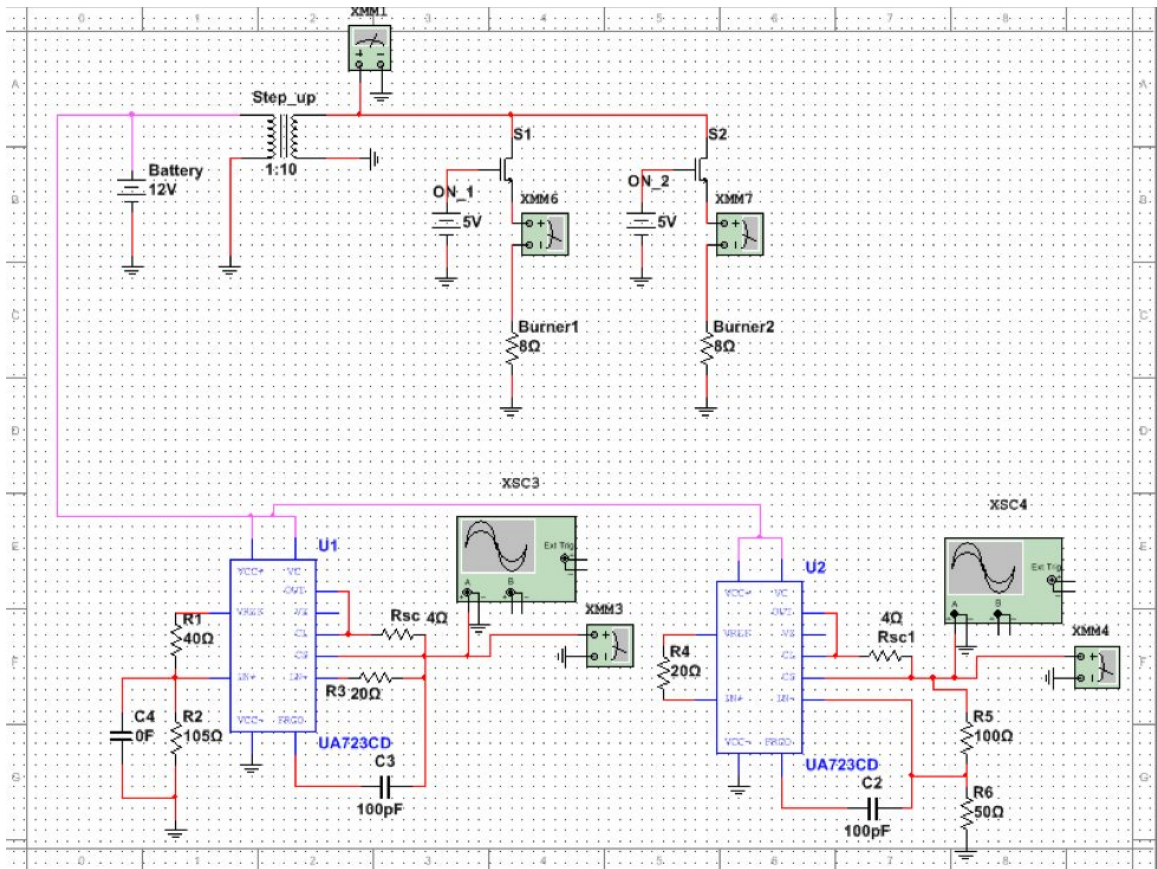

Smart Grill in already has a power outlet plug which hooks up directly to our 1800W burners. However, controlling our burners takes more understanding. In order to control an electric burner or element we had to understand how they actually work. For instance, voltages of 120V and currents of 10A to 15A that are

needed to operate the electric burners in normal operating conditions. An electric grill heats up its food by generating intense radiant heat (with temperatures anywhere from 200°F up to 700°F) which powers on and off thus reenergizing its heat coils intermittently on a timer or if the temperature drops. Therefore, searing foods may not be possible as it requires intense heat for long durations of time, even if it's only for 2-3 seconds. The component that allows the re-energizing of the heat coils is the burner switch, also called an infinite heat switch. They are referred to infinite because they control heat from high to low and everywhere in between.

Figure 5.1c

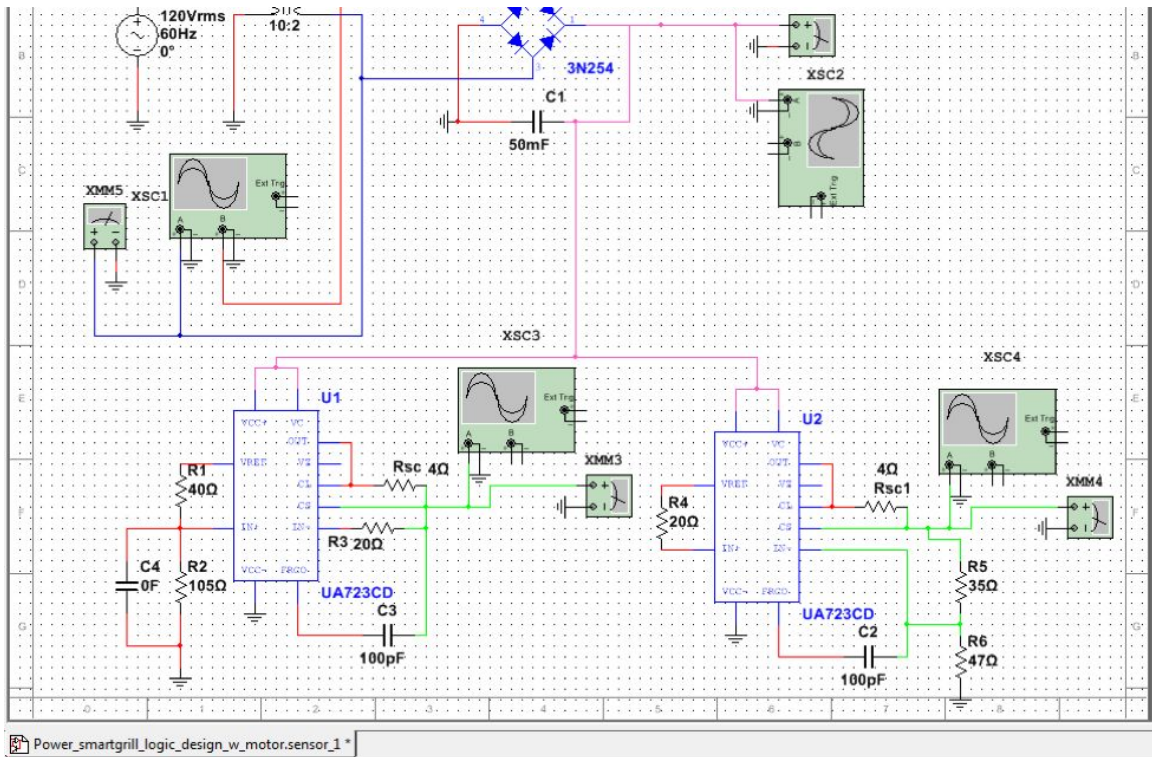

Smart Grill power supply starts at the source. In this case, either the wall outlet or the battery if no wall outlet is available. The power supply will have its own built in connection terminals for direct connection to the wall output. The nominal rated voltage and current for a wall outlet is 120V, 15A at 60Hz. This works out perfectly to connect the burners, which are rated the same. Since the burners are rated at 120V and 15A it means that the coil resistance is 8 Ohms. Since the burner coils are purely resistive, powering them with either AC or DC does not matter, as long as they see 15A. In order to turn the burners ON and OFF from the touchscreen or the mobile phone app a power mosfet needs to be implemented in series with the burners in order to control the current to each burner from signals via the MCU.

Figure 5.1d

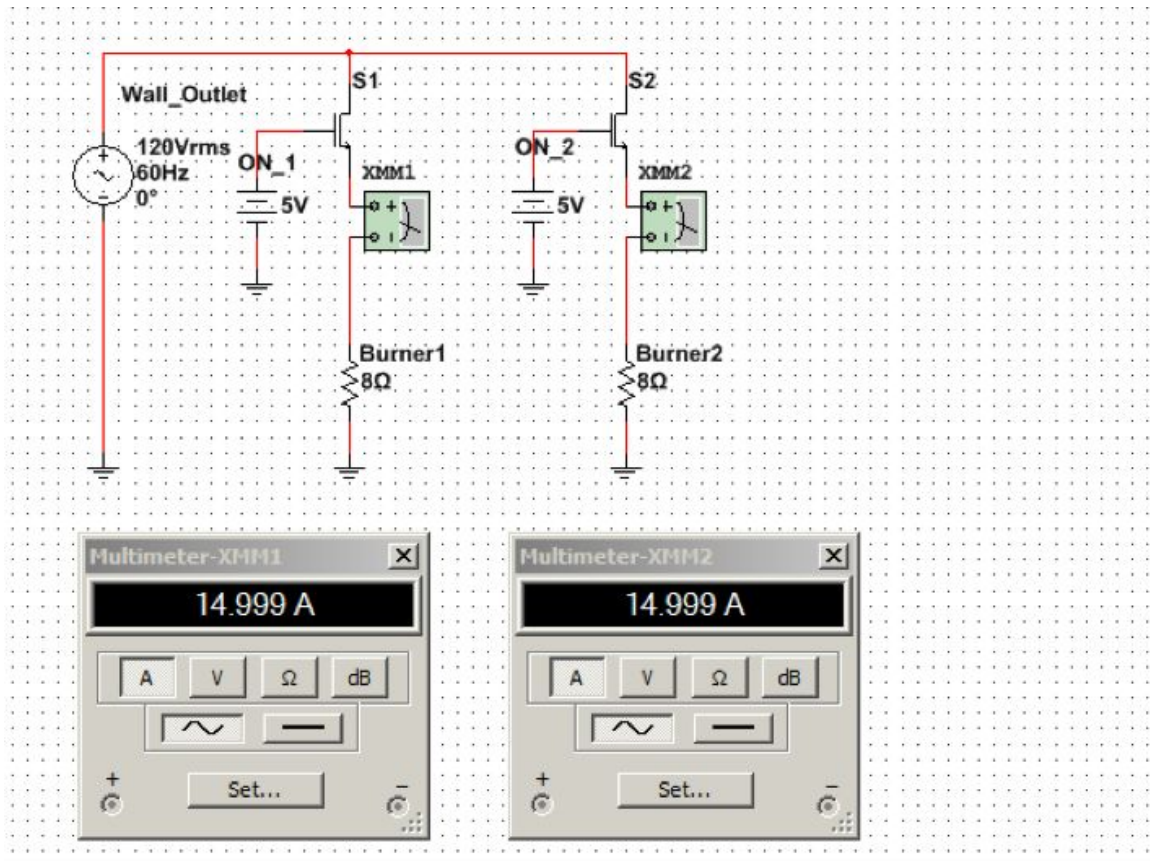

Therefore, in my schematic Figure 5.1b below shows the battery attached to the required voltages that will be needed when the battery is switched on in the event that no wall outlet is available as well as when a wall outlet is available and the battery needs to be charged. Although in the figure below I do not show the implementation of the battery gauge and charger they will simply be needed to hook up in parallel to the terminals of the battery itself in order to successfully implement the battery gauge for the LCD screen and the battery charger for recharging the battery when not in use. A majority of the power MOSFETs are used in switching between burners and power supplies and therefore will need at least five dedicated pins on the microcontroller to multiplex all the power MOSFET signals to operate in normal operating conditions.

Smart Grill power supply starts at the source. In this case, either the wall outlet or the battery if no wall outlet is available. The power supply will have its own built in connection terminals for direct connection to the wall output. The nominal rated voltage and current for a wall outlet is 120V, 15A at 60Hz. This works out perfectly to connect the burners, which are rated the same. Since the burners are rated at 120V and 15A it means that the coil resistance is 8 Ohms. Since the burner coils are purely resistive, powering them with either AC or DC does not

matter, as long as they see 15A. In order to turn the burners ON and OFF from the touchscreen or the mobile phone app a power mosfet needs to be implemented in series with the burners in order to control the current to each burner from signals via the MCU. When there is no power from the wall outlet the battery will be switched on to supply the power with the same type of power mosfets. On top of these switches, another power mosfet needs to be implemented in order to connect the battery to the wall outlet when Smart Grill is in OFF mode. Of course the 12V DC battery will need to be stepped up to 120V. Whether the battery voltage is inverted to AC is irrelevant and thus will be avoided if need be.

Figure 5.1d

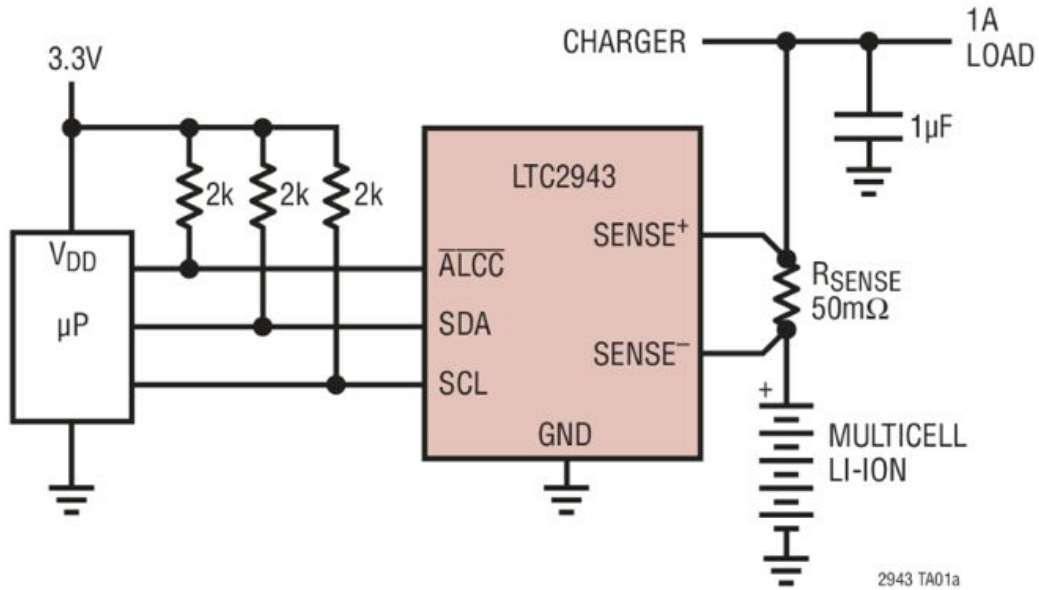

Permission to use Figure 5.1d given by Linear Technology

The battery gauge IC solution was chosen according to the batteries chemistry. Because I decided to use a lead acid battery there ended up being more IC solutions as opposed to using a lead acid battery for battery gauging. I wanted the gauge to be flexible and able to gauge accurately a wide range of input voltages. I decided to look at two of the Industries top battery gas gauges come one from TI and the other from Linear Technology. Where Texas Instruments excels in the impedance track algorithm where linear technology is very versatile in their solutions. Texas Instruments has the BQ34Z100-G1 which has a wide

voltage range of 3V to 65V with currents up to 32A and Support battery capacities above 29Ahr while operating under normal conditions with an average current of 145 microamps. This Texas Instruments fuel gauging solution also gauges multiple types of chemistry of batteries. This gauge however has 14 pins and the simplified schematic and implementation of this gauge is expensive and not practical for Smart Grill. The battery gauge that I ended up choosing for this project is the LTC 2943 from Linear Technology. This ic solution comes with the operating range of 3.6 volts to 20 volts and measures voltage current and temperature with 14 bit resolution + 1% charge accuracy. The +-50 millivolt sense voltage range will be more than enough to measure the accuracy of the charge of our 12 volt battery. The battery charger will be implemented within the step up transformer and discussed in the section of transformers in Power Management of Smart Grill. I decided to opt out of a charging IC due to high wattage applications and decided to buy an inverter power source supply capable of many things beneficial to the user among charging capability.

5.2 Transformers

The Transformers for my Multisim simulation we're the Transformers for my Multisim in simulation were basically virtual components and therefore didn't give me any indication on what specifications we're going to be needed. First of all I needed to take 120 volts AC from the wall outlet down to 12 volts DC for the regulator. In the Multisim simulation I simply used an AC to AC transformer then rectified this signal to invert into DC. The AC to DC converter solution offered by digikey product FSC-S5-5U is a 85 - 264 V AC voltage input with a 12 volt output and a max output current of 420 milliamps and a power rating of 5 watts. Since this transformer is for the logic part of the design which only uses less than half an amp, finding in IC solution for a wide range input output ratio for a cheap price is not very difficult, however looking for a step up transformer that's rated to handle 30 amps is much more expensive due to the increase in power protection for high wattage applications. Since the implementation of my battery requires a step up transformer to step the 12 volts to 120 for the burners I need to find a power inverter rated at at least what Smart Grill chassis is rated at, 1800W. I decided to go with the Cobra because I thought I could use it later for another project and it was the cheapest but most bang for the buck in terms of our specifications needed. The Cobra CT-02575 is an DC to AC power inverter that provides household power on the go. The Cobra is rated for 2500 continuous watts and 5000 Peak watts but only for short amount of time. The Cobra comes with a USB port that allows for charging of handheld devices as well which is another easy access point for the user.

Figure 5.2



After the transformer steps down the voltage for the microcontroller the power needs to be converted from AC to DC in which I use a full wave power rectifier to do so. Digi-key offers a very good solution with the CDBHD-220-G which features a reverse breakdown voltage of 20 to 60 volts and a forward current of 2 amps and has high surge current capability as well. The other great solution I found on the market, and the one I chose to use with Smart Grill, was from Vishay Semiconductors, GBU8B power rectifier, which offers 8 amp 100 volt rectifier with a max surge current of 60 amps which is great for being as safe as possible.

5.3 Regulators

Next in the signal chain would be the regulators. I decided to use two different regulators. The first regulator I needed to use was a 5 volt regulator for the microcontroller and the second regulator I needed to use was a 12 volt regulator for the PCB in order to power the pins which control the Power MOSFETs in smart grill power system. I decided to use two of the same regulators with a wide input and output range instead of different regulators of 5 volts and 12 volts. First regulator I looked at was actually from my Multisim simulation. The UA723 is a Texas Instruments precision voltage regulator that can receive input voltages up to 40 volts an output voltages adjustable from 2 volts to 37 volts and has a 150 milliamp load current capability. This voltage regulator is characterized for operation in a maximum temperature of 70 °Celsius. The other competitors that I saw was from Linear Technology, the LTC 3115-1. The specification Table 5.3 is below.

Table 5.3

BOM Part#	LTC 3115-1
Voltage:	2 - 37
Capacity	150 mA
Type	DC - DC switching
Max Temp	70 C
Efficiency	95%
Packaging	20 - lead TSSOP
Size	4mm x 5mm x .75mm

The LTC 3115-1 is a 40 volt, 2 amp synchronous boost buck DC to DC converter and features a wide input and output range of both 2.7 volts to 40 volts and up to 2 amps of output current in step down operation. The LTC 3115-1 has up to 95% efficiency and is thermally enhanced with 20-lead TSSOP packaging. It is relatively obvious to see you why I chose the Linear Technology IC solution for both 12 volt and 5 volt step down DC to DC converters. Figure 5.3 below is what our team decided to implement in Smart Grill.

Figure 5.3e below Figures 5.3b - 5.3d shows the output of the regulators as will be seen by the microcontroller when first powering on smart grill. The regulators input 12 volts from the rectifier and regulates the input voltage to a output voltage determined by components connected to the pins and can be realised in the datasheet. I used very common UA723CD Texas Instruments switching regulators to produce the required 5 and 12 volt output for the temperature sensors and motor as well as power MOSFETs. The formulas I used to reach a steady 5 volt and 12 volt output regulator voltage can be seen in Figure 5.3b below. I use the following Figure 5.3c correctly calculate the resistor and capacitor values attached to each respective pin (which can be seen in Figure 5.3d) then I tweaked each number. To get an output that was more favorable for smart grill. A power IC inputs unregulated voltage and outputs a regulated voltage. Sometimes the regulator has the ability to change the input voltage up or down in value. The first regulator under discussion is the linear regulator or LDO low dropout can produce a voltage lower than the supply voltage but not higher. So the linear regulator is only a buck converter or step down converter.

Figure 5.3a

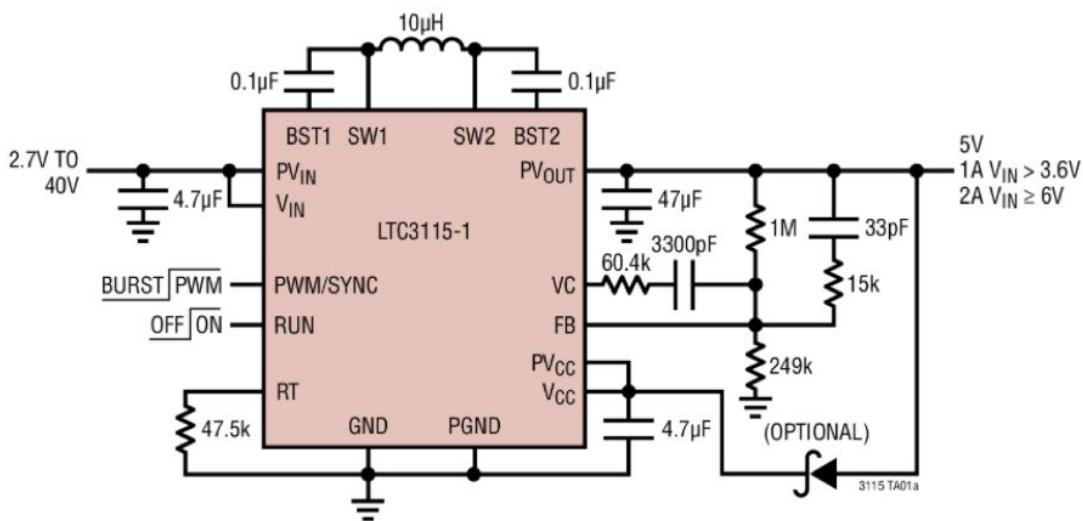

Permission to use Figure 5.3a given by Linear Technology

Figure 3.5b

OUTPUTS FROM 2 V TO 7 V SEE FIGURES 1, 5, 6, 9, 11, 12 (4) AND NOTE 5	OUTPUTS FROM 4 V TO 250 V SEE FIGURE 7 AND NOTE 5	CURRENT LIMITING
$V_O = V_{(ref)} \times \frac{R_2}{R_1 + R_2}$	$V_O = \frac{V_{(ref)}}{2} \times \frac{R_2 - R_1}{R_1}$ $R_3 = R_4$	$I_{(limit)} = \frac{0.65 \text{ V}}{R_{SC}}$
OUTPUTS FROM 7 V TO 37 V SEE FIGURES 2, 4, (5, 6, 9, 11, 12) AND NOTE 5	OUTPUTS FROM -6 V TO -250 V SEE FIGURES 3, 8, 10 AND NOTES 5 AND 7	FOLDBACK CURRENT LIMITING SEE FIGURE 6
$V_O = V_{(ref)} \times \frac{R_1 + R_2}{R_2}$	$V_O = -\frac{V_{(ref)}}{2} \times \frac{R_1 + R_2}{R_1}$ $R_3 = R_4$	$I_{(knee)} = \frac{V_O R_3 + (R_3 + R_4) 0.65 \text{ V}}{R_{SC} R_4}$ $I_{OS} = \frac{0.65 \text{ V}}{R_{SC}} \times \frac{R_3 + R_4}{R_4}$

NOTES: 5. The R1/R2 divider can be across either V_O or $V_{(ref)}$. If the divider is across $V_{(ref)}$, use figure numbers without parentheses. If the divider is across V_O , use the figure numbers in parentheses.
7. For Figures 3, 8, and 10, the device requires a minimum of 9 V between V_{CC+} and V_{CC-} when V_O is equal to or more positive than -9 V.

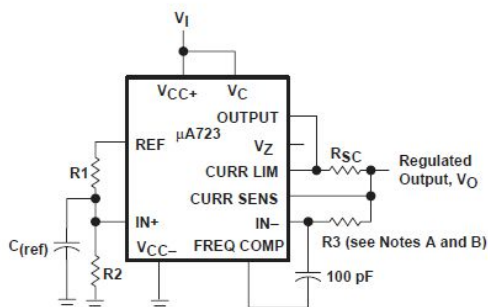

NOTES: A. $R_3 = \frac{R_1 \times R_2}{R_1 + R_2}$ for a minimum α_{V_O}
B. R3 can be eliminated for minimum component count. Use direct connection (i.e., $R_3 = 0$).

Figure 1. Basic Low-Voltage Regulator ($V_O = 2 \text{ V to } 7 \text{ V}$)

The UA723 features a simple typical application schematic by having the output voltage equal to a voltage divider with respect to your reference voltage. I decided to use the typical reference voltage in the data sheet of about 7.5 volts and since I needed 5 volt output that enabled me to pick appropriate values for R1 and R2 then Rsc by knowing a ballpark value for the output current to the MCU (which I chose to be the same for both 5 volt & 12 volt regulators at 4Ω).

Figure 3.5c

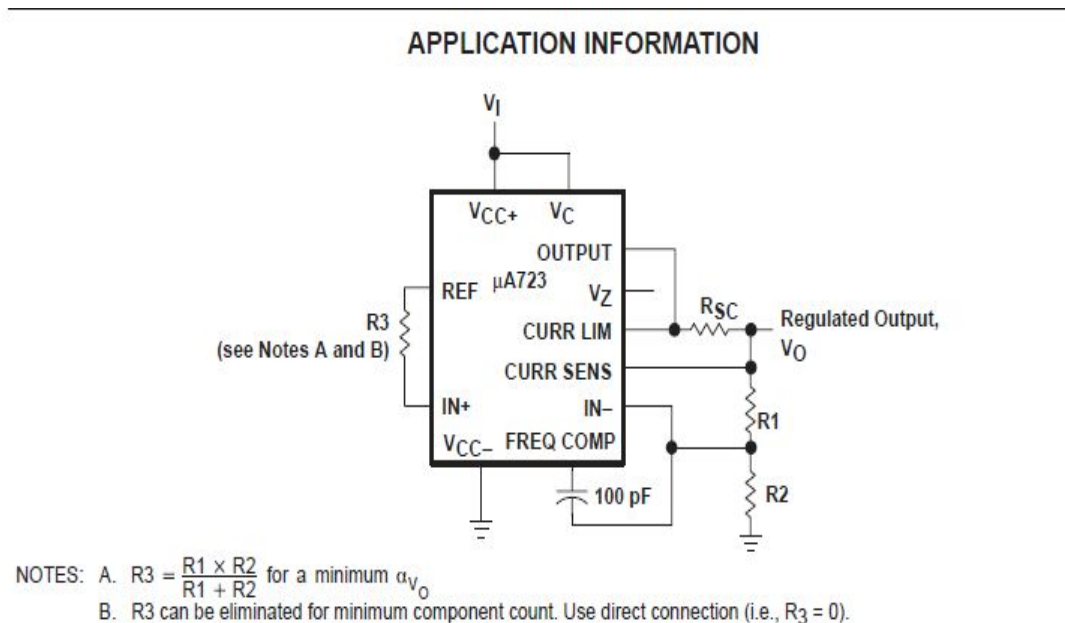

Figure 2. Basic High-Voltage Regulator ($V_O = 7\text{ V to }37\text{ V}$)

I used very common UA723CD Texas Instruments switching regulators to produce the required 5 and 12 volt output for the temperature sensors and motor as well as power MOSFETs. The formulas I used to reach a steady 5 volt and 12 volt output regulator voltage can be seen in Figure 5.3b below. I use the following Figure 5.3c correctly calculate the resistor and capacitor values attached to each respective pin (which can be seen in Figure 5.3d) then I tweaked each number. To get an output that was more favorable for smart grill. A low dropout voltage makes a good choice for portable and battery-powered applications such as the Smart Grill. Some of the other advantages of the linear regulator are inexpensive, low noise and small size.

Figure 3.5d

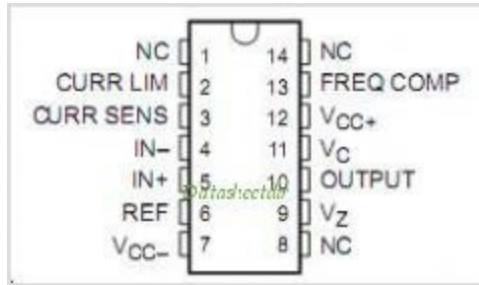
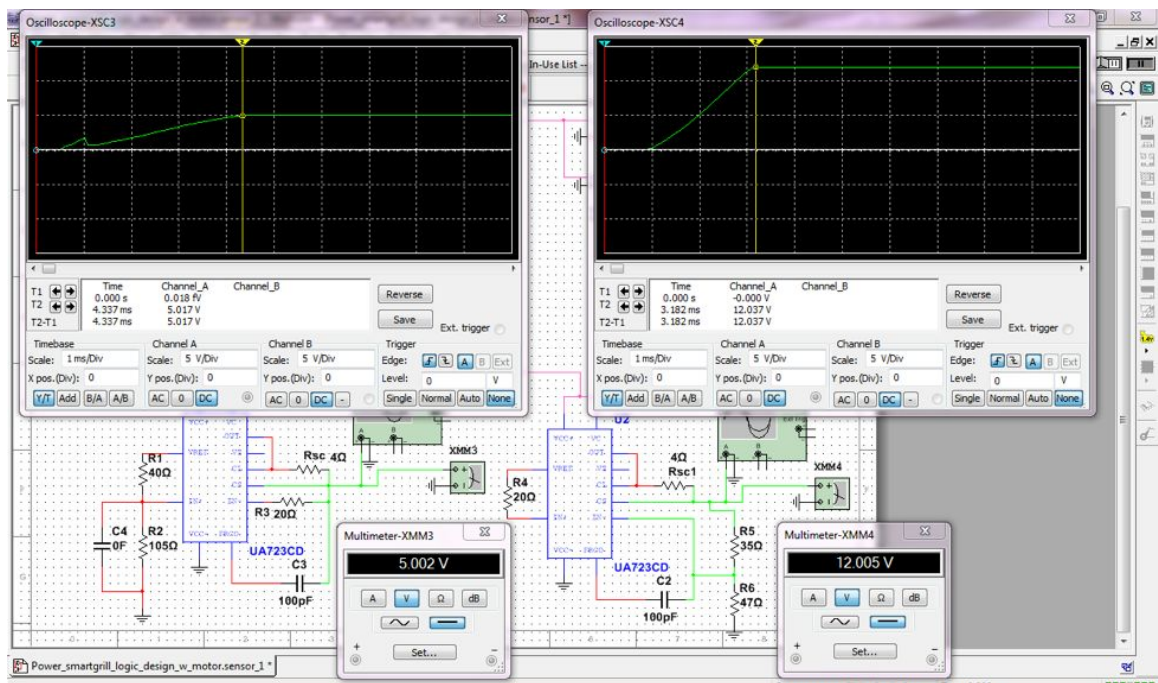

Figure 5.3e



The UA723 features a simple typical application schematic by having the output voltage equal to a voltage divider with respect to your reference voltage. I decided to use the typical reference voltage in the data sheet of about 7.5 volts and since I needed 5 volt output that enabled me to pick appropriate values for R1 and R2 then Rsc by knowing a ballpark value for the output current to the

MCU (which I chose to be the same for both 5 volt & 12 volt regulators at $4\ \Omega$). By using a similar technique to get the 5 volts regulated output I solved for a 12 volt regulated output by using the equation below the V_{ref} voltage divider and V_{out} voltage divider. I actually looked at the UA723 from Texas Instruments for implementing this regulator as I did in my multisim simulation but chose against this classic voltage regulator.

Figure 5.3f

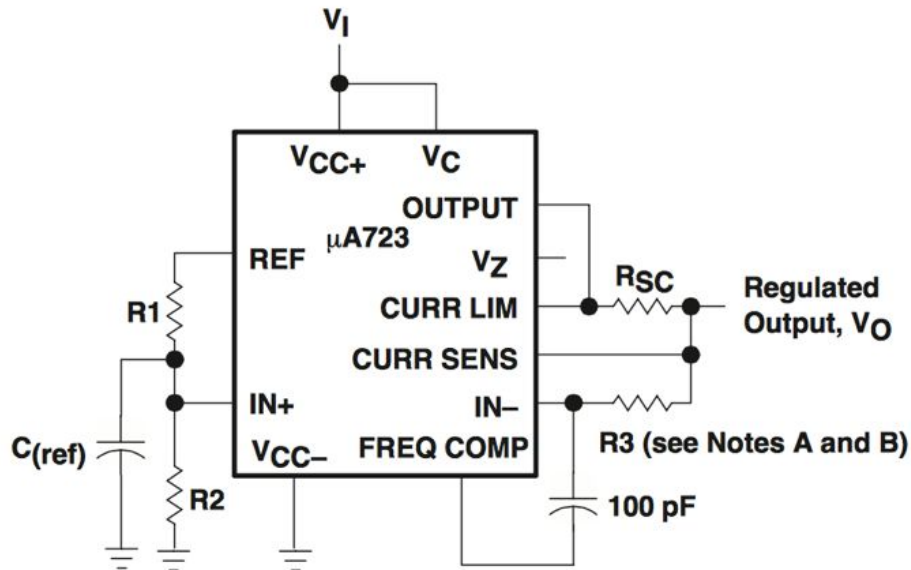

What's common in all home appliances that are electric in today's world is power regulation. And therefore a power regulator IC will be needed. A power IC has the ability to regulate the voltage in order to keep all of the subsystems operating at the required specification voltage range. A power IC inputs unregulated voltage and outputs a regulated voltage. Sometimes the regulator has the ability to change the input voltage up or down in value. The first regulator under discussion is the linear regulator or LDO - low dropout can produce a voltage lower than the supply voltage but not higher. So the linear regulator is only a buck converter or step down converter. The only difference between LDO and a standard linear regulator is that the LDO can operate with a very small voltage drop difference between the regulated output and the unregulated input voltage. An LDO might have a dropout voltage of 0.3 volts or less where a standard linear regulator offers a drop out of 1 volt or more. A low dropout voltage makes a good choice for portable and battery-powered applications such as the Smart Grill. Some of the other advantages of the linear regulator are inexpensive, low noise and small size. However, the linear regulator is very inefficient at as about 27% and as high as about 95% from a switching regulator. Since the linear regulator dissipates a lot of unused power as heat our group chose to regulate the 5V and 12V power supply for the MCU logic signals is a switching regulator.

5.4 Power Relays

For the power switches I decided to implement two completely different types of switches with similar specifications and then see which works better during my testing phase. The two switches I decided to test are the IRF-P260 from Vishay semiconductors which is a N-channel power MOSFET that can receive up to 200 volts and 46 amps and has a power dissipation of 280 watts. The rise and fall time are both about 30 nanoseconds and the maximum operating temperature is about 150 ° Celsius. The other switch that I wanted to implement is called a TRIAC from NTE electronics. The NTE 5679 TRIAC is designed for AC switching and phase control applications. The electrical characteristics of this triad feature voltages up to 600 volts current up to 40 amps and has a temperature range of up to 125 ° Celsius. The turn on time for this TRIAC is at a larger 5 microseconds as compared to the 30 nanoseconds, however the added durability to this switching component may be essential to Smart Grill. I wanted to note that the power MOSFET from the Vishay semiconductors should be more than enough to switch the burners on safely and with certainty. Therefore I will get both PMOS and NMOS power fets from vishay semiconductors in order to do the job of the TRIAC which can be used for everything. The reason I decided to go with a TRIAC vs a thyristor is because during AC switching the unidirectional switch only conducts during half the cycle similar to a half wave rectifier and there for half of the power is dissipated in the TRIAC making it less efficient for AC applications. Since I will be needing a TRIAC for AC power switching I'm going to get a TRIAC for anywhere that needs AC power switching and power MOSFETs for all DC applications in order to share the advantages of both switching components. Furthermore, I will instead use an N-channel power MOSFET for motor control and P-channel MOSFET for the temperature sensors. The following Figure 5.4 depicts our relay mission and solution:

Figure 5.4

Mission - Get variable -temperature for burner & ON/OFF (CW/CCW) control for rotisserie.

Solution - Use a Triac for switching power with simple pulse code for variable -temperature & ON/OFF (CW/CCW) rotisserie control.

- Constraint - use OEM burner & rotisserie features.

The first design in Figure 5.4a I decided to do in multisim was to simulate the burner power system separately. As can be seen in the figure below the wall outlet produces 120 volts RMS at 60 Hertz and is switch on and off by the capability of power MOSFETs. The MOSFETs I used here are all virtual, because I had a hard time finding a specific part number MOSFET that I wanted to use which matched my specifications, therefore, they will work under any current or voltage. The burners which can be seen to receive the required 15 amps are thus 8 ohm resistive coils. Is the microcontroller will be controlling the base of the two MOSFET switch switch on and off each burner respectively with a 5 volt or 0 volt control signal control signal depending on whether or not I am using P or N channel power MOSFET. Since I am switching a source to its load I decided to use a and moss power MOSFET so that the baseball pitch does not need to have the same voltage as the source which is 120 volts. Therefore with a N-channel power MOSFET controlling the burner system a 0 volt signal can be applied to the gate turning on power to each respective burner.

Figure 5.4a

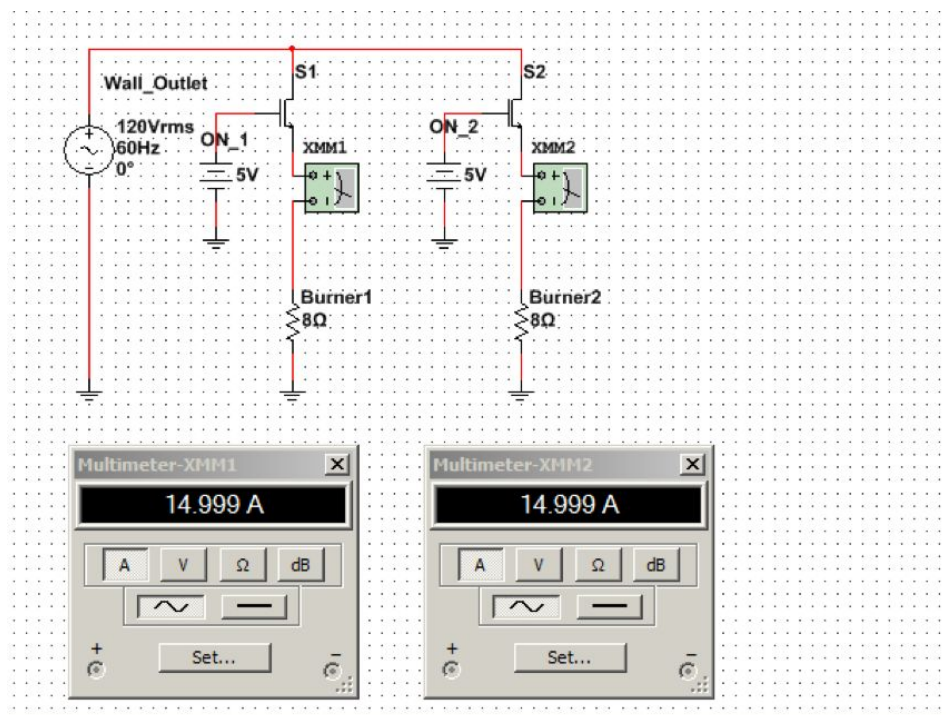

A solid state relay SSR is an electronic device we can use to switch the electrical current, rather than an electromechanical device. An electromechanical relay uses a magnetic coil and mechanical contacts. When current flows through the coil, it pulls down a piece of iron called an armature, causing the mechanical contacts to touch and thus close an electrical circuit. We had the choice of either a solid state relay or a mechanical relay. The solid state relay has no mechanical

moving parts, but instead uses a three terminal device such as a TRIAC, a back to back thyristors, or a field effect transistor FET to conduct the electrical current. When the third terminal is energized by the control input, the device conducts. Essentially the solid state relay controls a larger electrical current by accepting a small control signal. A main benefit of using it would be the fact that here are no moving parts. Also solid state relays have no internal arcing or contacts to wear out, so they can last virtually forever. They also have extremely low control input requirements, and are immune to vibration. An overview of Smart Grills relays and the corresponding specs are shown below in Figure 5.6b.

Figure 5.4b

POWER SYSTEM

- SSR - TRIAC
- Longer lifetime
- Need Heatsink
- Need safety enclosure

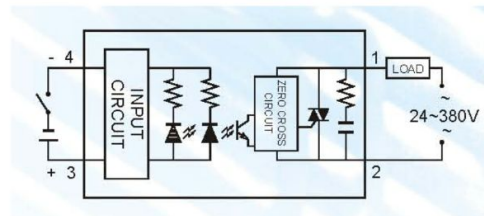

FOTEK SSR-25 DA

Input = 3-32 VDC

Output = 24-380 VAC

Max Current = 25A

Op. J.Temp. = 80C = ~180F

Switching ON/OFF Speed = <10ms

Motor Specs

- ~2 RPM Synchronous 120VAC motor
- Magnetic Memory
- Triac to control CW/CCW
- 15s motor -relay cycle - 10s ON 5s OFF

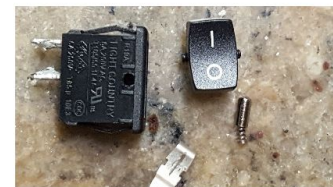

Rotisserie motor push switch

- Allowed us to figure out the rotisserie toggles CW/CCW

The objective of the Temperature sensor placement on the grill itself was extremely important. We needed three places so we put the burner temperature sensor directly on the burner, the ambient temperature sensor connected to the side of the grill on the inside and the Rotisserie/food temperature sensor on the back of the grill to be used manually. Figure 4.5 shows the Rotisserie/Food temperature sensor placement and how we worked around this with our relays.

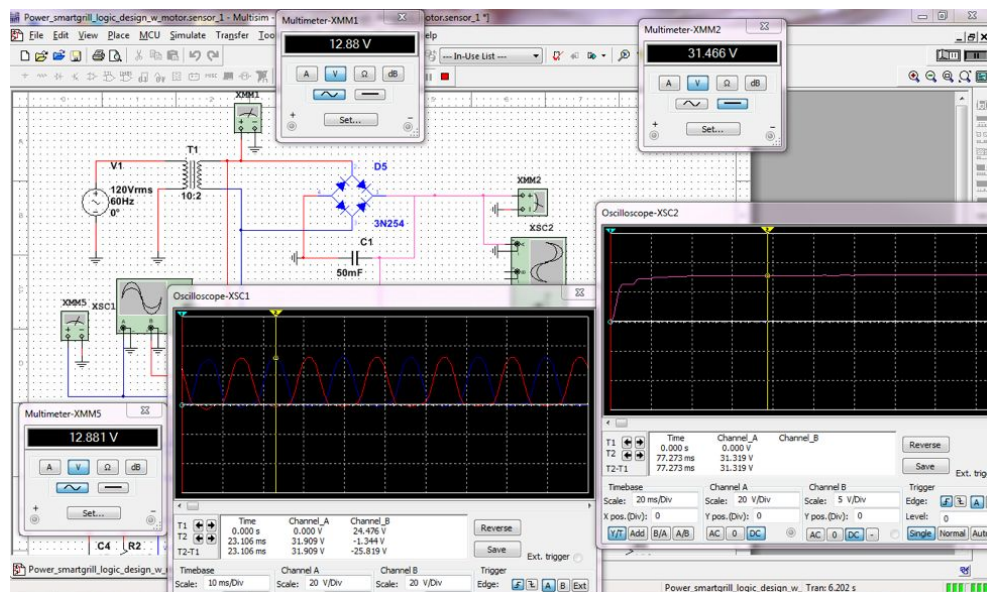

Figure 4.5

5.5 Rectifiers

The other power system that I need to look at with the AC wall outlet power source is the logic side of smart grill which connects to the microcontroller. The figure below is a Multisim simulation of all the components needed to achieve the required voltages to make smart grill operate in normal conditions. This is done by first transforming the 120 volts down to a manageable level to work with for the regulators. The transformer was essentially virtual as well and did not need to be considered for specifications into the design phase. Therefore moving on to the rectifier I decided to use for power diodes that stood up to specifications instead of a full wave bridge rectifier circuit because I was running into problems with getting the right voltages. However during the actual implementation of this power system I decided to use bay bridge rectifier with the 4 diodes already encased in the component for you in order to be more durable and safe. I ended up using 1N5401G diodes for my rectifier in my Multisim simulation. After successfully rectifying it I needed to make it more DC by incorporating a capacitor to produce the ripple voltage. It can be seen in Figure 5.5a that with a 100 microfarad capacitor value the output is rather wavy and full of ripples. However when increased 1000-fold from 100 microfarad to 100 millifarad the wavy ripple voltage goes away and is a nice clean signal for the regulators to regulate.

Figure 5.5a



With rectifiers it's important to understand that even a few milliamps of current can be fatal and it doesn't take a large voltage either. The more important aspect was electrostatic discharge and how we can reduce the risk of shocking

ourselves by touching our skin to a potential which is greater than the zero volt ground potential which we are standing on while working. For the power system and our safety, it is important that high voltage and current precautions take place. We can do this by metering all the voltages as well as wearing the proper attire with safety gloves where The buddy system will always be used. For the low power logic applications of smart grill it will be wise for us to use ESD or electrostatic discharge protection in order to avoid an ESD strike to permanently damage our PCB or PCB board components.

Figure 5.5b

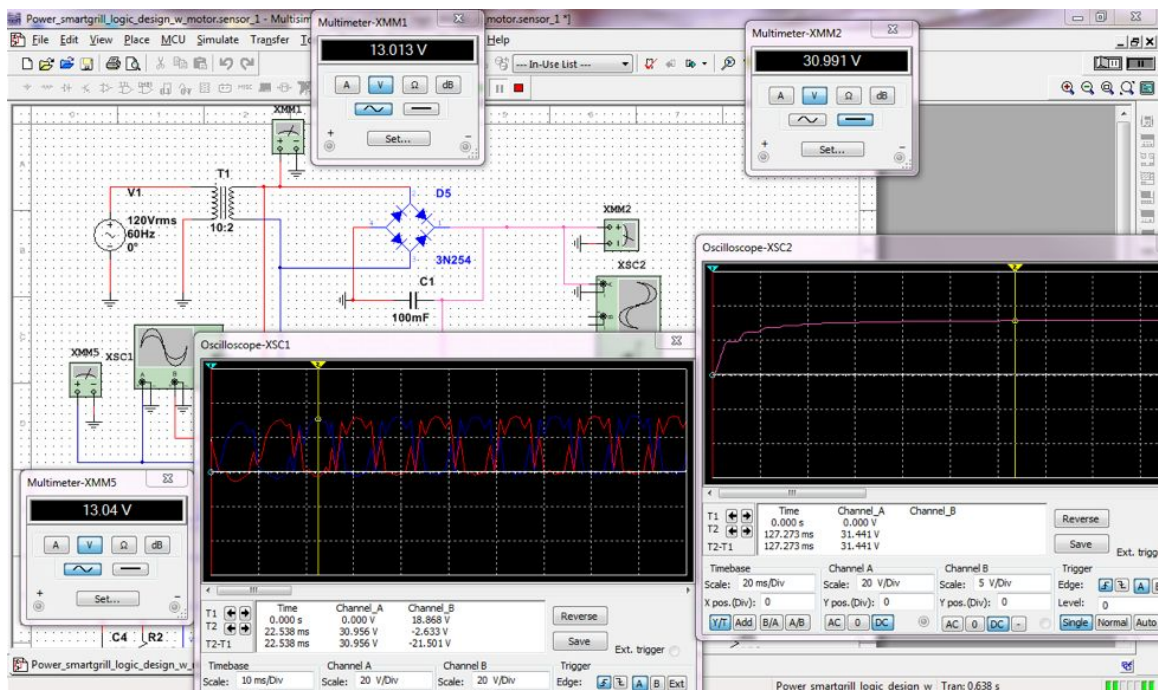

In Figure 5.5a above I am using the full wave bridge rectifier with a 50 millifarad capacitance and is pretty clean on all sides of the rectifier however I noticed a little bit of noise and distortion so I increased the capacitor size in Figure 5.5b above from 50 millifarad to 100 millifarad and saw that increasing the capacitor size on this full wave bridge rectifier did more trouble than good. I then decided to get rid of the uncertainty and use my own virtual diodes in Figure 5.5c below which worked out nicely which got rid of any voltage spikes before the power reaches the regulators and the microcontroller. However I noticed a +- 1 volt ripple voltage coming from the 50 microfarad capacitor. So in Figure 5.5d I increased the capacitor value once again to achieve a clean signal to feed into the regulators. Another advantage of this solution from the Vishay semiconductors is the maximum operating temperature is 165 degrees Celsius. I

decided to use the Vishay semiconductors solution you too the extra flexibility in current and voltage ratings as well as durability with hot temperatures.

Figure 5.5c

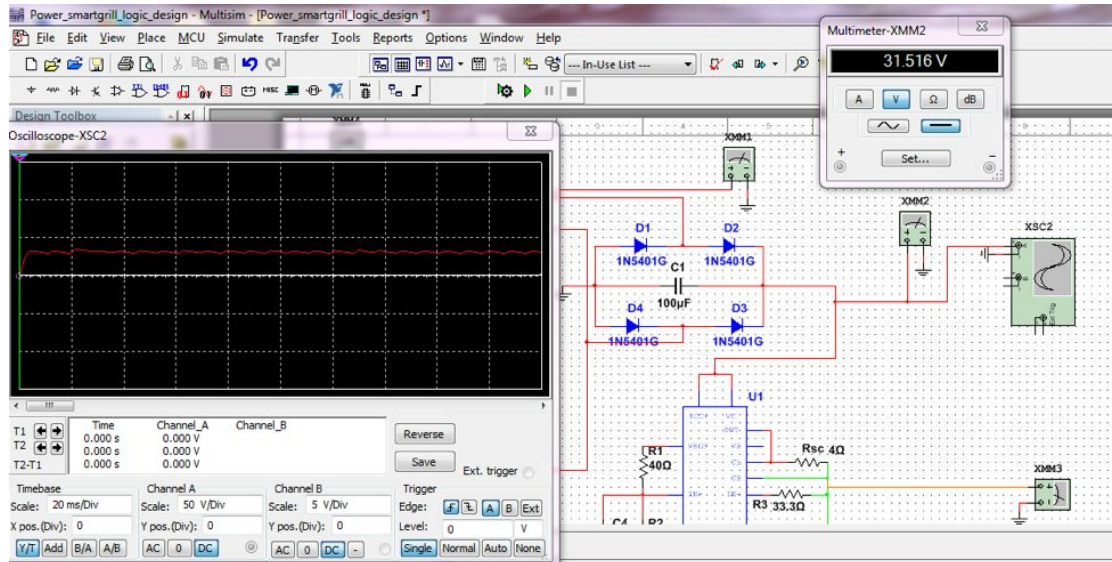

With rectifiers it's important to understand that even even a few milliamps of current can be fatal and it doesn't take a large voltage either. The more important aspect was electrostatic discharge and how we can reduce the risk of shocking ourselves by touching our skin to a potential which is greater than the zero volt ground potential which we are standing on while working. For the power system and our safety, it is important that high voltage and current precautions take place. We can do this by metering all the voltages as well as wearing the proper attire with safety gloves where The buddy system will always be used. For the low power logic applications of smart grill it will be wise for us to use ESD or electrostatic discharge protection in order to avoid an ESD strike to permanently damage our PCB or PCB board components.

Fortunately, after building smart grill we decided that the whole battery system would not need to be implemented due to budget and practical constraints. Therefore, although it's not necessary to have remote power capabilities on smart grill there is always a possibility to do this so I decided to keep all my work on making smart grill its own power supply.

Figure 5.5d

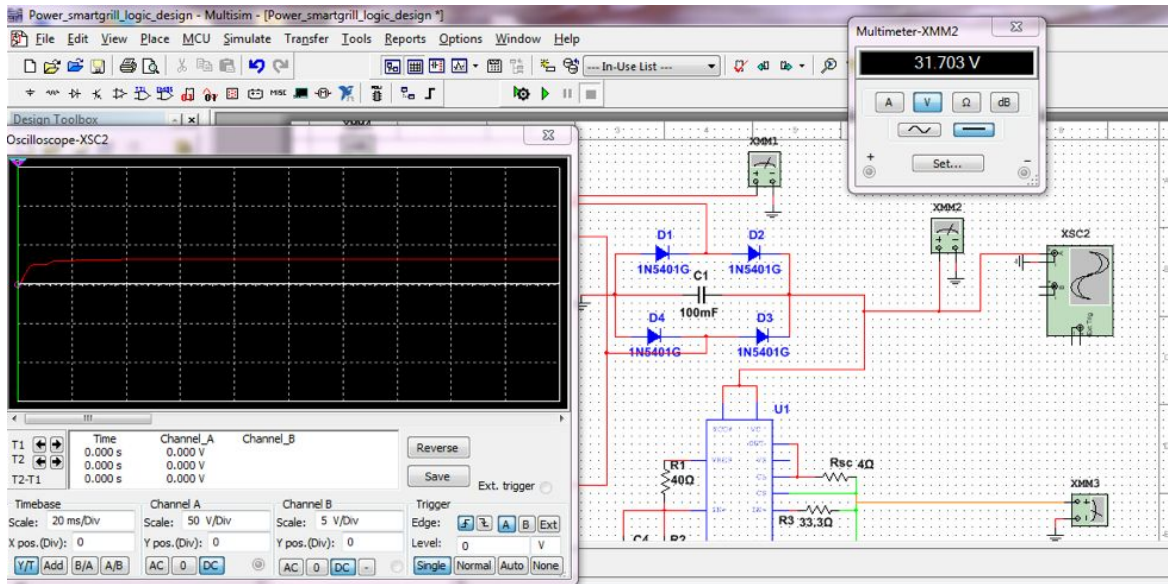

The figure below shows the OEM burner system and how we accessed every component.

Figure 5.5e

POWER SYSTEM



Burner
Terminals



Bimetal
Thermostat



Making things fit
OK



6 Final Production

6.1 PCB/Circuit Design

The PCB design was created by first using a virtual breadboard. This finished design prototype of the breadboard is what we will use to test our components before we actually attach them to the PCB. The breadboard created in the software can be seen in Figure 6.1a on the following page. This breadboard design is centered around the ATmega328 microcontroller that we will be using for our project.

The power supply will come in through the DC barrel jack seen on the right side of the design. This will pass the 12V DC voltage through a diode and resettable fuse. After, a voltage regulator will drop the voltage down to 5V which is the required voltage for all of the components on the PCB and is connected to the red bus rails on the breadboard.

To ensure this microcontroller functions as it should the three pins for VCC, AREF, and AVCC are connected to 5V. There are also two ground pins on both sides of the microcontroller that can be seen by the black wire. A 16 MHz quartz crystal is attached to pins 10 and 11 on the microcontroller to serve as the clock. Both of these are connected to ground by 22 pF capacitors. Pin 1 on the microcontroller is attached to a 10K ohm resistor which is attached to 5V. This is to keep the microcontroller from resetting itself over and over. If we find it useful, a button could be added to make a reset button for the microcontroller.

On the right side of the breadboard is our bluetooth module notated by RN-42. This connects to 5V and ground with the red and black wires. The orange and yellow wires go to the microcontroller's TX and RX pins so that the two devices can communicate back and forth. For temperature sensing, the three black boxes on the left side of the breadboard are what will be used to plug the temperature probes into the circuit. As mentioned in the design section of the temperature sensors, these will be connected to a voltage divider circuit with 10K ohm resistors. The blue wires going back to the microcontroller connect these probes to the analog inputs of the microcontroller so that it can read the changes in voltage.

The LCD has 30 pins in 2 rows of 15 to communicate back and forth to the microcontroller and also physical components which can be seen in the bottom left. The purple wires go to the LCD's analog inputs as well so the temperature can be displayed on the screen. This setup may need to be modified once we receive the physical parts and see how things interact with each other. The LCD also connects to VCC and has two ground pins which can be seen on the connector next to the breadboard.

Figure 6.1a

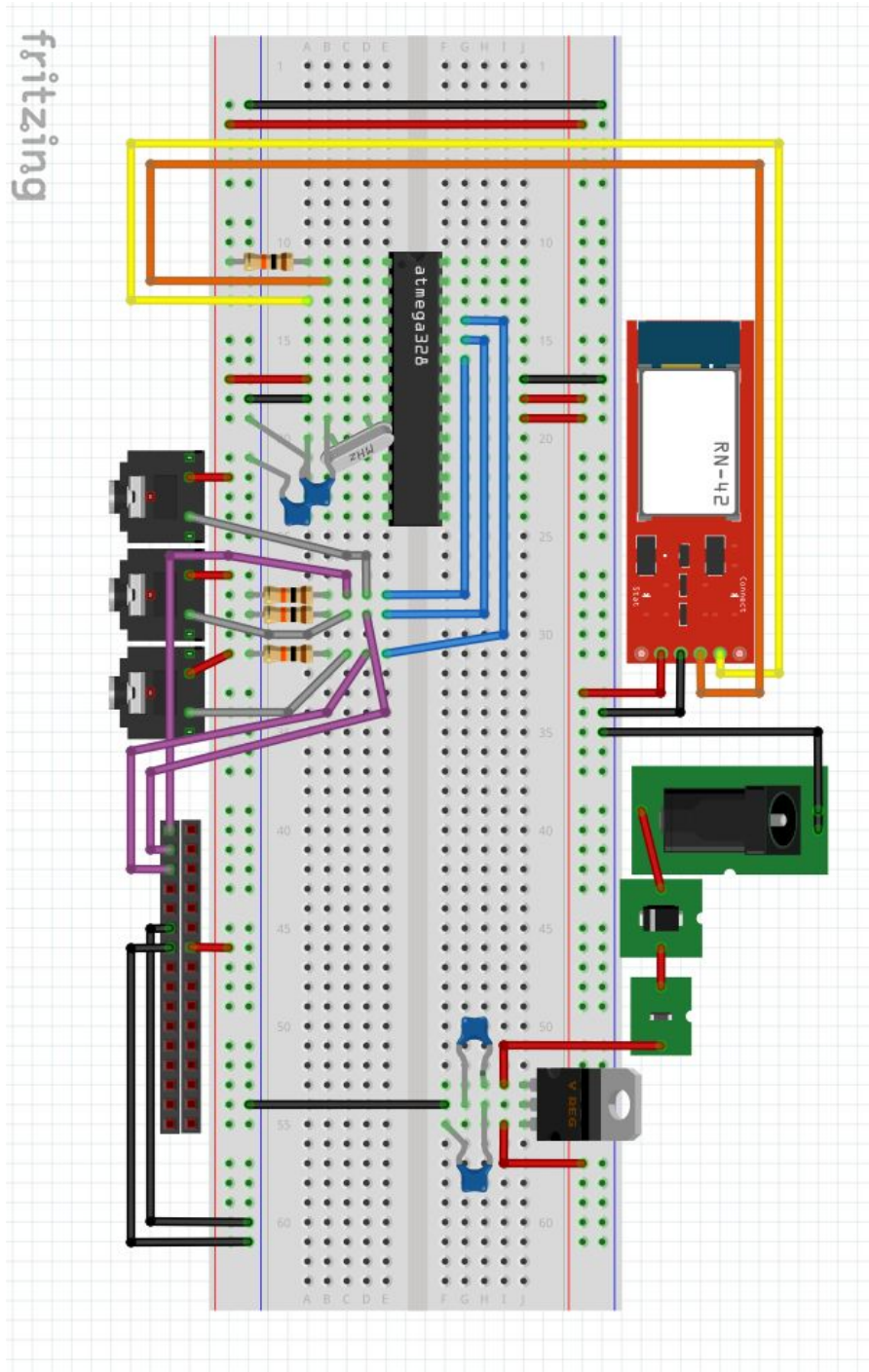

The schematic view was made next which can be seen in Figure 6.1b.

Figure 6.1b

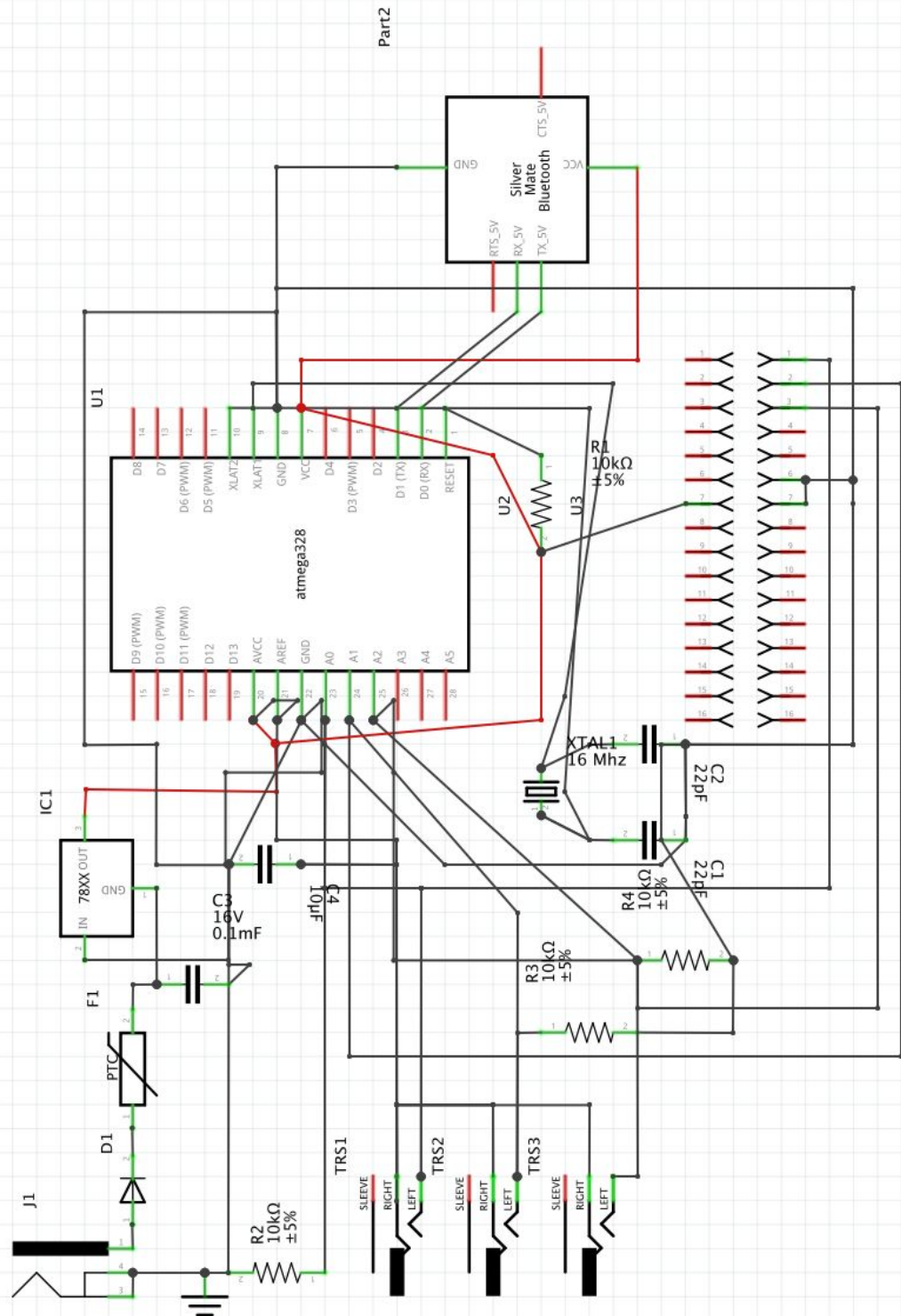

Part2

The schematic was a little difficult to get nice and neat and will need to continually be revised. Ideally the ground lines would all be connected and straight at the same point although being the first time creating a schematic with this software made it a little more difficult. There were some programming errors with the Fritzing software that are evident in the schematic. The 78XX voltage regulator is connected as specified in the data sheet on the breadboard but it is incorrectly wired automatically in the schematic mode. This goes the same for the bluetooth module. However, once moved to PCB view, the pins all connect in the correct locations.

Even though the schematic view is a little incorrect it still translates to the correct PCB placement, which is the most essential component. More pins on the ATmega328 will also need to be used on the final design. The elements for the burner power supply may even be added onto our PCB if it can fit within our budget. However, this was to get a rough idea of how the software works and how it will be implemented in our smart grill design.

The connectors on the schematic for the temperature sensor are notated by TRS1 - TRS3. These are connected to the 10K ohm resistors and to their respective analog input pins which is a little unclear on the schematic. Some of the lines are not straight as it was difficult to see what connected where in some instances so diagonal lines were implemented. The software only had connectors for 1 X 16 ports instead of 2 X 30 ports for the LCD touch screen. To compensate for this, we used two 1 X 16 ports side by side for the schematic and for the PCB design. If we keep it like this for the final PCB fabrication, we will just use the last port of both column unconnected and only utilize the top 15 pins.

The PCB design view can be seen in Figure 6.1c on the following page. The yellow traces on the board represent the traces on the top layer and the orange traces are for the bottom layer of this two layer PCB design. The biggest challenge with designing the traces for the PCB is ensuring that no traces overlap in the same layer that aren't apart of the same node. In this design, the bluetooth module is resting on top of the PCB. However, we may change this design depending on if we need to save real estate space on the PCB for other power components or outputs from the microcontroller.

The DC power back will stick off the PCB by a little along with the three 3/32" headphone jack ports for the temperature sensor. Eventually, this entire PCB will be placed into an enclosure that only has openings for the DC input and the temperature sensors. The LCD touch screen can be mounted on top of or on the side of this enclosure for simplicity and to minimize the number of exposed wires. Most of the components such as the resistors and capacitors will be surface mount components. The final design for the PCB layout will also need to include a few mounting holes so that the PCB can be securely attached to the enclosure housing it.

Figure 6.1c

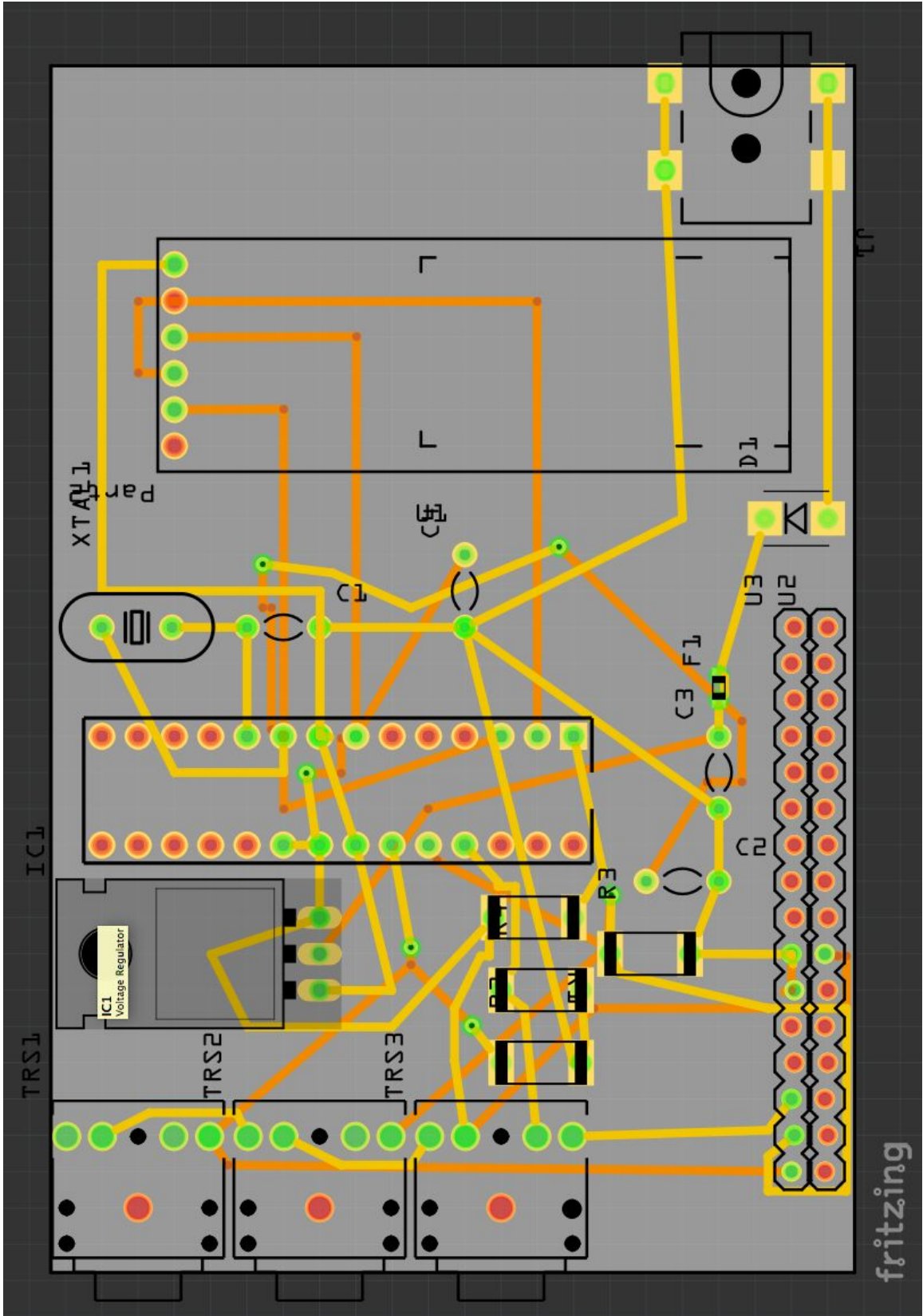

6.1.1 Design Software

The PCB was designed using a software by the name of “Fritzing”. The Arduino website offers a lot of great tutorials about how to use their projects. A lot of these tutorials offer graphics of how the breadboard should be setup. After looking into how these are created we discovered the program Fritzing. Fritzing allows you to lay all of your components out on a breadboard. Once they are connected how they are supposed to be, the design can be exported to schematic view.

Schematic view allows you to create a detailed view of all of the connections. There is also an autoroute feature to connect all of the components to the correct nodes. Finally, once the schematic is in order, PCB view can be utilized to layout the physical parts on the virtual PCB. This gives the the option to autoroute as mentioned previously for the schematic view. You can also design the traces on the PCB for two or four layer boards. It is very easy to redesign the board and more things around if needed. When the final design is decided on, the Fritzing software can export the design into several different files. These files will then be sent to the manufacturer as mentioned in the following section, 6.1.2 Fabrication.

6.1.2 Fabrication

The PCB that will hold our ATmega328 microcontroller and other essential electronic components for our project will be fabricated by the company OSH Park. OSH Park will fabricate two layer PCB boards for \$5/sq inch and four layer PCB boards for \$10/sq inch. For the smart grill project we will most likely only need a 2 layer board as we don't have too many components on our PCB. If we can make our design work for a 2 layer board, that will cut the cost of the PCB in half.

Every order submitted through OSH Park is for three PCB which is convenient and allows room for error if something needs to be corrected. If this were to be made on a large scale, the price of the PCB drops significantly. If you order 10 or more in one order the price is \$1/sq inch for two layer boards and \$2/sq inch for four layer boards. Ideally if this project were to be manufactured, then making 10 or more at a time would cut down a lot on the cost of parts. The files that are created using the Fritzing software discussed in section 6.1.1 Design Software will be uploaded to the OSH Park website. This checks the designs for consistency and will allow them to be submitted to be fabricated. After submitting our PCB design to OSH Park it will take about three weeks to receive our

completed PCB. After that point, we will need to hand solder all of our components onto the board and begin testing the PCB.

After creating all the Gerber files required for the PCB we uploaded them to Gerbview in order to have Osh Park ship them. Each layer had to be uploaded individually into their website and then the PCB was ordered. The completed uploaded PCB design was loaded into Gerbview as shown in figure 6.1.2a.

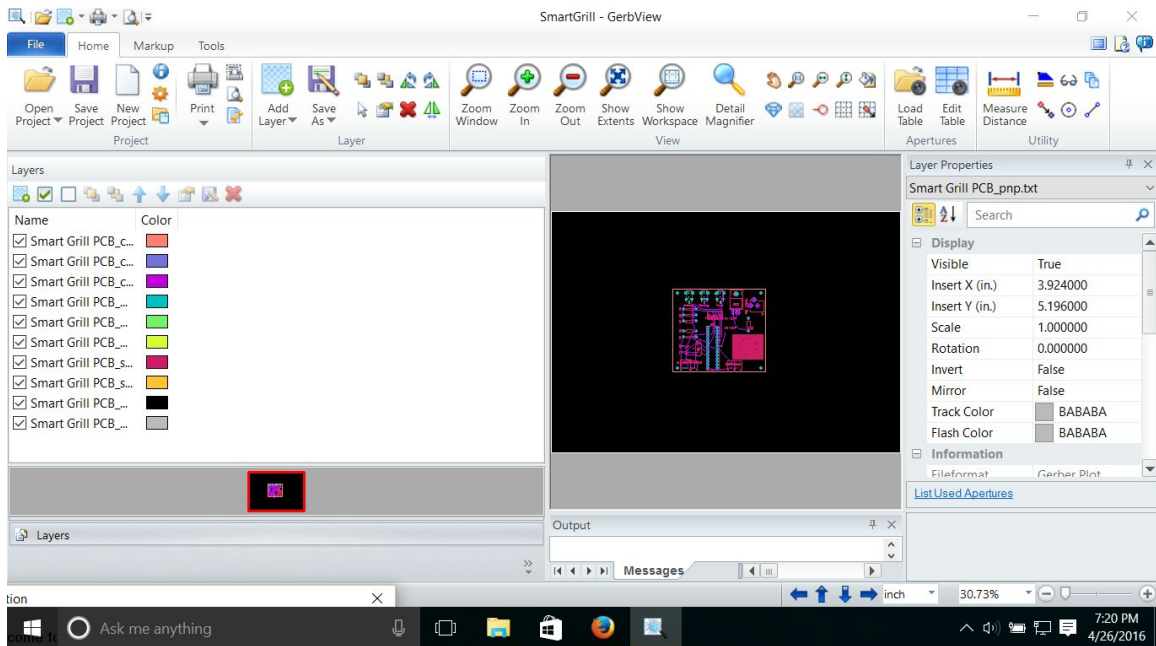

Figure 6.1.2a

7 Project Prototype

7.1 Hardware Specific Testing

The project will be tested in what will as closely as possible approximate a real end user application. A scenario will be set up with Smart Grill and a cookout. In this scenario the group hopes to demonstrate the rotisserie and temperature sensors work as well as mobile app for easy use, which one of the project goals is to reduce. The scenario will then also demonstrate the food grill accessibility and mobile phone features based on differing constraints.

In the scenario, 4 hotdogs and 4 hamburgers will be grilled in and operated in different modes to demonstrate the power changing capabilities of Smart Grill and the power to cook each piece of food completely. Showing the total power usage over time was also a requirement to test the accuracy of, which will mean

we need to grill this scenario multiple times to get a good idea how accurate our battery is. Then, the ability to use the touch screen to turn on or off specific units will be demonstrated by allowing one of the evaluators to perform the task also demonstrating the ease of use of the system to control remote Smart Grill.

Once manual control has been demonstrated, automatic control will be demonstrated, using pre-programmed settings to demonstrate the capabilities in a timely manner, say an accelerated practical 2 hour period condensed into 5 minutes, showing that depending on the set temperature, the system will handle things differently. On top of all the automation demonstration, the system will also be tested against commercial power metering products. Hotdogs and hamburgers are inexpensive and will be used to do the testing with the hopes that as their food cooking statistics can easily be calculated 'on paper' and the group can compare the expected values with the actual values of both the commercial products and the project. Smart Grill will be tested with loads ranging from large to small, say a large chicken and a single hotdog.

7.2 Software Specific Testing

In order to properly assess the app, a couple of tests must succeed in order for the app to be successful. The tests will evaluate functionality in terms of the following: does the user get the correct results based on the input and does the app have all the features mentioned in the specification.

In order to connect to the grill, the app must connect to the microcontroller via Bluetooth technology. To test this portion, the Bluetooth option must be turned on the phone, then the user will search for nearby devices. After connecting to the grill (microcontroller), the app will display a message indicating the two devices have properly been connected together.

The user will create a profile by tapping on the signup button and then typing their username and a password. After creating a username and a password, a welcome message will be shown on the screen indicating if the profile was successfully created. To test if the profile was created and to verify if the logout option works properly, press the logout button. The home screen should show up in which the signup and login option should show. Press signup and enter the same username and password; this should not work and a message should appear indicating that the username already exist. Try entering a different profile. The best way to test if the profiles were created is to check the Parse database.

After signing on, the app should take you to a new screen. The new screen should have the user's username display, which will indicate the user is in the right profile. The screen will also have all three temperatures from the sensors.

The temperature of all three can be measure be a thermometer and compared to the readings to the app in either Celsius or Fahrenheit. Also the LCD Screen would also show the proper temperature reading. The app also allows the user to use either Celsius or Fahrenheit, therefore the results of the conversion will also be tested manually. An alarm rings when the timer finish or if the temperature becomes too high. Set the grill to 100 degrees without the food, then wait to see when the alarm goes off.

Android Studio comes with virtual emulator. The app will be first run on one of the many phones offered. The virtual phone that will will most likely be used is the Samsung Galaxy Nexus API 16 which uses a MIPS CPU. An old phone will then be used to test the app. The app can be tested on both a phone and a tablet, although we are more developing for a phone.

7.3 Food Product Testing

There are many variables when it comes to testing our food product. Many variables include type of food product, amount of food product, ambient temperature, grill burner temperature, degree of product doneness. Below table 7.3a displays various food products and variables we will most likely be using for testing our food product. This also could change due to various budget concerns as well unforeseen incidents that may occur while in actual hands on testing phase of the project. This table shows general as well as actual parameters we will use. Time, temperature and more factors may vary.

Table 7.3a

Food Type	Thickness	Doneness/ Cooking Time per side	Cooking Temperature
Beef: Steaks, Kabobs	1" thick	rare / 3-4 min medium / 5-6 min well / 6 - 7 min	125°F - 130°F 145°F - 150°F 160°F +
Beef: Hamburger	3/4" thick	rare / 4-5 min medium / 5-6 min well / 6 - 8 min	125°F - 130°F 145°F - 150°F 160°F +
Roasts	Rump Rolled (4-6lbs) Rib (6-8lbs)	rare / 20 min per lb rare /16-18 min per lb	140°F 160°F

		med / 18 -20 min per lb	170°F
Chicken	Whole 2 ½ - 3 ½ lbs	35-45 min per lbs	175°F
	Skinless (6-8 oz) Boneless Breast	6 - 8 min per side	175°F
Fish (fillet or steak)	½" - 1 ¼" thick	5 min per inch of thickness per side	165°F
	Whole fish	8 -10 min per side	
Shrimp & Scallops	1 ½ oz	5 min per side	130°F
Pork Chops	1" thick	6 - 8 min per side	170°F
	2" thick	10 - 13 min per side	
Ham	Fully cooked	4 - 6 min/lb per side	140°F
	Uncooked	6 - 9 min/lb per side	160°F
Potatoes	Whole	30 - 40 min per side	160°F
	¼" slices	5 - 10 min per	

7.3.1 Specific Food Testing

We cooked a couple of specific products for before choosing which product to use for our demonstration and presentation. We started with the basic hamburger cooking it directly on the burner. The grill itself preheats to 450°F but we cooked our ¾" hamburger patty to the recommended 160°F. We wanted it to be cooked to well-done. The hamburger patty itself was at an initial temperature of 40°F as it just come out of the refrigerator. We decided to set the cooking temperature to 160°F. The smart grill cooked the hamburger patty perfectly to the doneness and temperature that we had anticipated. We decided against cooking the hamburger patty for demonstration and presentation purposes due to the amount of time required to cook the hamburger. We flipped the hamburger several times periodically, but total cook time was (30) minutes as shown in table 7.3.1a. Also another reason for not using the hamburger for demonstration purposes was grill cleanliness being an issue.

Measured Temperature and Cook Times

Grill Temperature (°F)	Cook Time (min:sec)
40	0:00
45	1:15
50	2:30
55	3:45
60	5:00
65	6:15
70	7:30
75	8:45
80	10:00
85	11:15
90	12:30
95	13:45
100	15:00
105	16:15
110	17:30
115	18:45
120	20:00
125	21:15
130	22:30
135	23:45
140	25:00

7.3.1a

Since fish cooked relatively quickly in comparison to most other food products we decided to test cooking fish. We decided to cook the fish to 165°F and going by the recommended times from Table 7.3a we cooked each side of the fish about 8 minutes a piece. The fish cooked fairly well to what we expected, but it was extremely difficult to clean the burners and grill afterwards so we eliminated this product for demonstration and presentation purposes.

We then cooked chicken on the the grill to the recommended 175°F. The hamburger patty itself was at an initial temperature of 60°F. We decided to set the cooking temperature to 175°F. The smart grill cooked the chicken, but we had to flip it a few times. We decided against cooking chicken for demonstration and presentation purposes due to the amount of time required to cook the chicken was too long. We flipped the chicken several times periodically, but total cook time was (28) minutes and (45) seconds as shown in table 7.3.1b. Also another reason for not using the chicken for demonstration purposes was grill cleanliness being an issue. The chicken had a tendency to stick to the burner and required a lot of cleaning

Measured Temperature and Cook Times

Grill Temperature (°F)	Cook Time (min:sec)
60	0:00
65	1:15
70	2:30
75	3:45
80	5:00
85	6:15
90	7:30
95	8:45
100	10:00
105	11:15
110	12:30

Table 7.3.1b

We were going to cook a few other products including steak, a few vegetables but decided we did not need to test that many more products. For the actual testing of the grill for demonstration and presentation purposes we kept it simple by cooking only a hotdog on the rotisserie and inserting the Rotisserie/Food Temperature probe into the hotdog to measure the temperature of the hotdog. U.S. specific safety standards for cooking a hotdog to the appropriate temperature is set at 165°F. For testing purposes we decided to start cooking the hotdog with an initial temperature of 65°F and set the cooking temperature at 100°F. We used a stopwatch to measure the time interval required to cook the hotdog at a specific temperature interval. This interval was the basis for most food product cooked on the grill.

Jonathan programmed the LCD screen to round the temperature value, shown on screen in both preheat and cooking screens, up or down to the nearest 5°F. In doing this the LCD only displayed the temperature in increments of 5°F. With cooking the hotdog initially at 65°F and setting the final temperature to 100°F we determined it takes (1) one minute and (15) seconds to increase each temperature interval 5°F. Using this statistic it took us (8) minutes and (45) seconds to cook our hotdog from 65°F to 100°F. The results of the test are shown below in figure 7.3.1c.

Measured Temperature and Cook Times

Grill Temperature (°F)	Cook Time (min:sec)
65	0:00
70	1:15
75	2:30
80	3:45
85	5:00
90	6:15
95	7:30
100	8:45

Figure 7.3.1c

8 Related Standards

8.1 Standards

There are specific engineering standards that relate to cooking and grilling in general. These standards are in place to ensure that grills are utilized and manufactured in a manner that is consistent and keeps people safe. Here we list some important standards from NFPA 96, 2014 edition relating to our project. Although some of the standards may be more applicable for large scale commercial usage, it is still relevant as an electric smart grill could be scaled and be useful in a commercial environment.

4.1 General

4.1.1 Cooking equipment used in processes producing smoke or grease-laden vapors shall be equipped with an exhaust system that complies with all the equipment and performance requirements of this standard.

4.1.9 Cooking equipment used in fixed, mobile, or temporary concessions, such as trucks, busses, trailers, pavilions, tents, or any form of roofed enclosure shall comply with this standard unless otherwise exempted by the authority having jurisdiction in accordance with 1.3.2 of this standard.

4.2 Clearance

4.2.1 Where enclosures are not required, hoods, grease removal devices, exhaust fans, and ducts shall have a clearance of at least 457 mm (18 in.) to combustible material, 76 mm (3 in.) to limited-combustible material, and 0 mm (0 in.) to noncombustible material.

4.8 Materials

4.8.1 Noncombustible Material

4.8.1.1 A material that complies with any of the following shall be considered a noncombustible material:

- (1) The material, in the form in which it is used, and under the conditions anticipated, will not ignite, burn, support combustion, or release flammable vapors when subjected to fire or heat.
- (2) The material is reported as passing ASTM E 136, *Standard Test Method for Behavior of Materials in a Vertical Tube Furnace at 750 Degrees C*
- (3) The material is reported as complying with the pass/fail criteria of the ASTM E 136 when tested in accordance with the test method and procedure in ASTM E 2652, *Standard Test Method for Behavior of*

Materials in a Tube Furnace with a Cone-shaped Airflow Stabilizer, at 750 Degrees C

5.1 Construction

5.1.8 Eyebrow-Type Hoods

5.1.8.1 Eyebrow-type hoods over gas or electric ovens shall be permitted to have a duct constructed as required in Chapter 7 from the oven flue(s) connected to the hood canopy upstream of the exhaust plenum as shown in Figure 5.1.8.1.

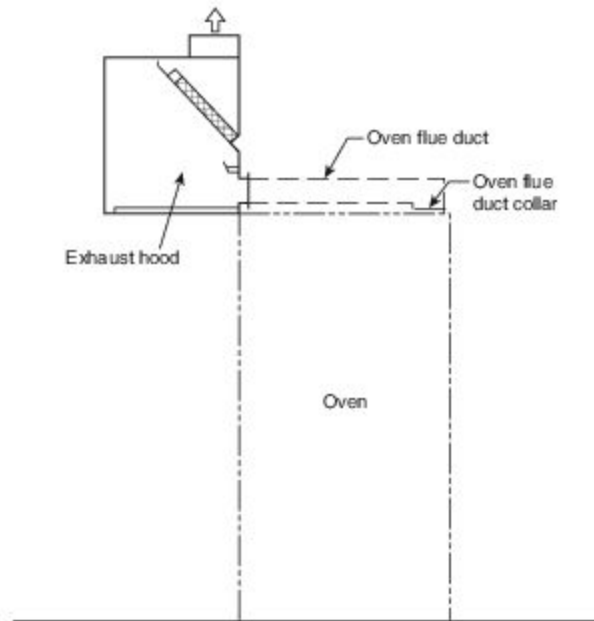

FIGURE 5.1.8.1 Typical Section of Eyebrow-Type Hood.

10.1 General Requirements

10.1.1 Fire-extinguishing equipment for the protection of grease removal devices, hood exhaust plenums, and exhaust duct systems shall be provided

10.1.2 Cooking equipment that produces grease-laden vapors and that might be a sources of ignition of grease in the hood, grease removal device, or duct shall be protected by fire-extinguishing equipment.

10.2 Types of Equipment

10.2.1 Fire-extinguishing equipment shall include both automatic fire-extinguishing systems as primary protection and portable fire extinguishers as secondary protection.

10.2.2 A placard shall be conspicuously placed near each extinguisher that states that the fire protection system shall be activated prior to using the fire extinguisher

10.4 Fuel and Electric Power Shutoff

10.4.1 Upon activation of any fire-extinguishing system for a cooking operation, all sources of fuel and electrical power that produce heat to all equipment requiring protection by that system shall automatically shut off.

10.4.4 Shutoff devices shall require a manual reset.

12.1 Cooking Equipment

12.1.1 Cooking equipment shall be approved based on one of the following criteria:

- (1) Listings by a testing laboratory
- (2) Test data acceptable to the authority having jurisdiction” (NFPA, 2014)

8.2 Discussion on Realistic Design Constraints

Some of the design constraints for the grill were mentioned above in Section 2.4 on Design Constraints. However, there are some additional constraints that will be discussed here. When it comes to building the grill, we are not going to be able to fabricate a grill from scratch. Therefore, we will be buying an electric grill that already functions as intended out of the box.

From here, we will make our modifications to the grill to add the additional features of a smart grill. This is partially due to time constraints that will be discussed in the following section (8.3 Economic and Time Constraints) but also because the aim of our project is to take an ordinary grill and give it features of a smart grill. By doing this, building the grill itself isn't the point of the project, it's optimizing an existing grill. By using this method for our project it could allow for grill manufacturers to implement our ideas in their design for future models of grills so that a smart grill will come out of the box instead of a regular grill that will need a bunch of add ons.

Another constraint to this design would be that it will need to be somewhat portable. The grill will need to be transported from the place that it is being worked on to UCF so that way it can be demonstrated next semester. This leaves some limitations as far as how big it can be and what features it can have. The grill that we have chosen comes on a cart with wheels which will make it more portable and will not have to be carried, so all of the additional features for the grill will need to be added to the cart that comes with the grill itself.

8.3 Economic and Time Constraints

There are economic constraints for this project due to the fact we have a limited budget of \$1200. We also don't have any sponsors for this project so we are paying for all of the manufacturing costs and parts out of pocket. Due to this constraint, the quality of some of the parts we are using may be compromised in order to stay within the selected budget. However, this is not necessarily a bad thing because in the market this idea could be scaled with a more expensive model that uses higher quality components.

The grill itself should be pretty nice and do everything that we need it to do, however it is not a top of the line grill. This may have problems as far as working for a really long period of time as some cheaper products can have reliability issues down the road, however for the purpose of our prototype the grill that we have chosen should be sufficient for the project and demonstration.

The project has the obvious time constraint where the prototype needs to be showcased in May when the spring semester ends. Due to this, we have planned for our smart grill to have scalable features in case there is an issue with the grill once we build the prototype. The first scalable feature would be the ability to make multiple food items. Due to the economic constraint we have for our budget, we would most likely do our original testing with a cheaper food item such as a hotdog. Once we get the grill to be able to cook a hotdog on its own with minimal help from the user as our grill is intended to do, we could then scale up by adding additional food items such as hamburgers, steak, chicken, and vegetables. If for some reason, due to time constraints on the project, we are unable to add that many food options, the prototype will just need to showcase at least one for the purpose of demonstration. From there, it could be inferred that additional food options could be added if time was allowed to get the programming and parameters correct.

Another scalable feature for the grill would be the rotisserie feature. The grill that we will be using for the smart grill project comes with a rotisserie and motor already attached. However, this will be a feature we focus on after we get the basics of the grill cooking food on the electric burners. While utilizing the rotisserie, the food cooks from the hot air rising from the burners, so things will be a little different as far as calibrating the time and temperature. Another important variable is the rotational speed of the rotisserie which will need to be adjusted for optimal cooking. All of these parameters can be factored in once we get the grill working correctly. Since the rotisserie feature is not ideal for all types of food that can be made on electric grill, it will most likely be implemented after we get a successful burner cooked food item working properly. This would help

showcase the differences between the two cooking methods and how they would be implemented with our smart grill.

8.4 Social and Political Constraints

A big focus on social and political factors right now are going green and utilizing energy more efficiently. This grill will help with that to some extent as cooking time could be optimized by ensuring that the grill is constantly monitoring the food leaving less room for human error. Therefore, the food will be cooked faster and more efficiently. However, due to some other constraints, we will need to use some parts that may not be the most efficient in order to save money. Although our goal with the smart grill is not efficiency, the concept behind energy conservation is still there and the grill could be made to be “green” with the appropriate funding and using our technology.

8.5 Ethical, Health, and Safety Constraints

The smart grill is designed to have minimal assistance from the user. Therefore, there may be times that the smart grill is unsupervised. Due to the excessive heat that will be produced from the grill burners, this could potentially cause a fire hazard. Therefore, we should appropriately warn the user to keep the grill away from flammable objects and to also not leave the grill unattended for extended periods of time. Although it may not be implemented by the time our prototype is showcased, a feature could be added alerting the user if abnormal temperatures are detected from the temperature sensors. This could indicate that something caught fire and is giving off more heat than one would expect. After sensing such a condition, the burners could automatically shut off as to not further aggravate the situation.

We are also avoiding possible health concerns by using an electric grill as opposed to charcoal, since charcoal cannot be safely burned indoors, an electric grill could theoretically be indoor or outdoor. There are other ethical concerns about if one should eat animal products and cook them on a grill. There are also health concerns around the slight increase of cancer due to eating processed meats. However, these concerns will not be addressed by our smart grill product and will not constrain our design in any way.

8.6 Manufacturability and Sustainability Constraints

As far as large scale manufacturability goes for this product, there are already similar products on the market which do this. To sustain our grill that we build long term there may be some limitations and constraints. As mentioned previously, the grill is not the best grill you can buy so there may be time down the road where parts would need to be replaced sooner than a more expensive grill. Also, the temperature sensors will constantly be subjected to heat and wear and tear which could eventually lead to them needed to be changed out.

Due to the lack of time and resources, not all desirable features or extensions can be included in the project. Given more time, and proper resources, the system would surely be more advanced and user friendly.

One future improvement is the idea that the accuracy of the system could be improved to the level where it would be acceptable for any possible use – even to the point where home appliance companies would approve the use of the grill. In order to do this, higher tolerances would need to be implemented, such as more bits in the analog to digital conversion to give a more accurate reading as well as more accurate analog parts. While accuracy of data transmitted was one of the major components the group sought to take care of, the accuracy of the data collected was equally important. However, due to the ability of the group and costs of the bits, and high standards and safety constraints, it would be difficult to improve upon the original idea to the point where it would be acceptable for this type of use at this time.

The device could also have been made smaller, and possibly cheaper, with more development time and a greater in-depth knowledge of the different parts of the system. If the group could have been expanded, or the time of the group's efforts could've been equivalent to small research and development division of a corporation, it's possible the group could have produced a smaller product.

Another advanced feature would be the ability for the system to know the proximity of the user and accept the commands over the internet. This way, a user would never need to use the console to dictate commands to turn modules on and off; the device itself would know. This could be accomplished by interfacing a GPS to detect the user moving around.

More software features can be added such as the ability to control your unit from the internet. These features would add to the overall value and utility of the system. Either of these features would need to include WiFi or Ethernet support to the system, and a server to be included with the software package. This may not be possible with the current processor and embedded solution. Some old personal computer parts may be able to facilitate this function.

9 Administrative Content

Our design group consists four senior electrical engineering students. The members include Jeff Mueller, Thierry Alerte, Jon Graff, Jonathan Schooley. We have decided to split the research and design into 4 main parts where each group member is given an equal amount of work. Each of us will be working on separate parts of the project, however pairing up in teams of two throughout our group is likely to happen due to our conflicting schedules. We believe it is very important that each group member is completely competent in understanding the entire design of the project. Therefore, at each group meeting we explain to each group member what we have accomplished and how it works.

Thierry has taken on the role of researching and designing the user interface of the system. Thierry is responsible for researching the different kinds of touch screen monitors available today and the pros and cons each. He is also in charge of selecting the main microcontroller to power the touch screen monitor and wireless RF communications between power strip modules. Jeff and Thierry together are designing appearance of the GUI interface and is also writing the code to implement it. Last he will also be writing the code for the microcontroller receiving and transmitting data from the power strip modules and making sure that information is displayed neatly and accurately to the touch screen monitor.

Jeff and Thierry has taken on the role of researching and designing the wireless communications between the major components in the project. Jeff and Thierry will be researching the latest technologies in wireless communications and determining what technology will work best for our project. Jeff and Thierry are also in charge of researching the analog to digital and digital to analog conversions needed for transmitting and receiving the data from the microcontrollers.

Jeff has taken on the role of researching the the power system needed for the subsystems to operate effective and efficient. When designing a power supply considerations are to provide safe and reliable power, while also delivering high performance with low power consumption and low bill-of-material (BOM) cost. Jeff is also working with Thierry for determining whether a standard microcontroller such as the Arduino is needed or maybe something more application specific. Jeff is also responsible for the gauging circuit for the battery as well as any appropriate calculations for power measurements from the sensors. Jeff will have to also consider how hot or how many watts are the electric burners able to produce and how will this system be powered. Lastly, Jeff will then help write the code for the microcontroller to receive and transmit data from the touch screen display and mobile app Thierry is designing.

Jonathan has taken on the role of researching and designing the circuits and sensors needed for our subsystems to operate efficiently. Jonathan and Jeff are working closely together to ensure compatibility of sensors and microcontrollers and any additional circuits need to connect the two and make them operational.

Jon is the mechanics behind this entire project. He is researching and designing the anything that moves in the system. Jon is designing the motor for the rotisserie system. He is also designing the housing for the grill. Another important task Jon is faced with is finding a solution for a grill that can cleverly cook with either electric burners or charcoal.

9.1 Milestones

For the purposes of this project, there are a few main stages to its creation which are universal for most products going through development. Design processes typically go through a five stage system sometimes going back and forth between the stages as needed. The five stages are: definition, research, design, prototype, and testing.

For the first semester of this project in Senior Design I, we focus mostly on the first three stages during the months of August through December 2015. For Senior Design II, we will finish up with building the prototype and testing the design during the months of January through May 2016. This should give us ample time to create a working prototype of the smart grill we originally envisioned in August 2015. To ensure we are on track for the completion of our design, we have implemented milestones to ensure we are moving through the design process efficiently.

9.1.1 August/September

The first two months working on the Smart grill composed mainly of the Definition phase. Our group needed to decide on a project that we wanted to do and there were a couple of different options considered. This phase of the project consisted mainly of defining our motivation, goals, objectives, specifications, and requirements. A lot of what we developed during the definition phase is found in the second section of the documentation. Once we decided on doing the Smart Grill project, we had to decide what type of grill we wanted to build. Between electric, gas, and charcoal grills we figured that an electric or charcoal grill would be best to use.

Since charcoal is quite messy, cannot be utilized indoors, and the heat is somewhat difficult to control from an electrical control system, an electric grill was decided on because it was more realistic. Not only can an electric grill be used indoors and outdoors, it is a lot more straightforward when it comes to controlling

the heat of the grill using electric burners instead of a fire burning on charcoal. Using an electric grill over a gas grill also eliminates the need for natural gas which would have placed more constraints on our budget for the project.

9.1.2 October/November

After defining the project in September and getting our project approved, we began doing research on the different components we would need to build a smart grill. The obvious components such as the grill housing and temperature sensors were a major focus. The first half of October was spent doing research. Our research consisted mainly of learning about design methods, components to use, previous smart grills, and different design architectures. We remained in the research phase until we began working on our project documentation in mid October. The project documentation began by compiling information we had found in the research phase of the design process. With this research we were able to begin to come up with the design and the logistics of the smart grill.

When November began we had officially entered the design phase of our product development. The Design phase consisted of creating block diagrams, schematics, methods of manufacturing the prototype, and data structures for the microcontroller coding. All of this design that we came up with was also documented in the project documentation along with the research. While documenting design details, we would constantly need to return to the research phase to learn more information about how things worked. For example, when planning out the LCD touch screen user interface, we had to go back and do a lot of research on how the design program for the layout of the screen worked. Not only did we have to learn a new computer program, we had to do research with how it would be integrated for use with a microcontroller for the purposes of the grill project.

9.1.3 December/January

The month of December will begin by us finishing up our project documentation. The documentation needs to be finished by December 12th at 12:00PM so we are planning to finish the writing of it a few days before. This will allow time to finish making changes to the table of contents so that the page numbers on it correspond with the page numbers throughout the documentation.

Most of the editing has been taking place using Google Docs due to the ability for all members of our group to simultaneously edit the document. However, there are some limitations as we are not able to do things like the lower case roman numerals to page numbers before the Executive Summary. These formatting details will need to be corrected using Microsoft Word after we are finished writing the contents of the documentation. Once the document is finished, we will

need to make a hard bound copy to turn in which will also take place in the days prior to the 12th.

After the semester is over, we have a couple of weeks before Senior Design II begins in January. During this break Thierry and Jeff are going to get together to begin working on the Prototype stage of the design process. Beginning in January, we will need to actually purchase that parts that we have identified to be used on our grill. This project documentation outlines all of those parts but we will need to actually purchase them and start putting them all together starting in mid January. Once we have all of the parts we need we will need to get together and determine a place to actually fabricate the grill prototype.

9.1.4 February/March

By the month of February we should already have the majority of the components that we will need to assemble the smart grill. During these two months of February and March we will need to completely finish building the prototype and begin testing. The Prototype phase should consist of building the grill and implementing our design, buying our parts from vendors, and writing the code for the microcontroller that will be running the project. Ideally we will be able to begin testing mid-March, although with Spring Break it may be pushed back more towards the end of March. During the assembly process we will probably need to test certain components as we go to ensure they are working correctly.

For example, when we connect the burners from the grill to the power supply we will be utilizing for the project, we will need to do a lot of trial and error to get it working to how we would like it. From here, we would need to use a working thermometer to calibrate the temperature sensors we are making from the thermistors. Therefore the prototype and testing phases pretty much go hand in hand as far as this project is concerned.

9.1.5 April/May

April is essentially the last opportunity for us to get our project in 100% working condition. By this month, all of the construction of the grill needs to be completed and we should be entirely on the testing phase. This is also the point where we could introduce new and extra features such as the rotisserie or the charcoal option. We are leaving these as optional features to be included if everything goes as planned. However, if we need more time to work out the practicality of the original smart grill idea, we will omit these from the final design.

This month will be primarily filled with testing and tweaking our design. The testing phase should be composed of testing the equipment in a specified environment, measuring the results from the tests, and providing test cases. As

far as the grill testing goes, we will need to ensure that each one of our food options available on the grill can be cooked to perfection based on the input defined by the user.

In the month of May, we only have a week or so until the semester is over so we will need to be completely wrapped up with everything. Everything will need to be working seamlessly by this point and any additional features need to be completed or left out. In the month of May we will be presenting the final prototype of the smart grill and will be finished with our project.

9.2 Budget

For our smart grill project we have set a maximum budget of \$1200. This cost should cover all of the parts that will be necessary to fabricate the smart grill. We will have some extra room in our budget to cover any unforeseen costs such as part failure or the need to go in a different direction and change out a part for something else.

9.2.1 Parts

Within the set budget we will need to find parts for each of the following categories listed on the flowchart in Figure 9.2.1a. This flowchart gives a breakdown of what big picture parts will be needed and what smaller components will be needed to make them work properly. As an example, the PCB Board will also need microcontroller and headphone jacks to work as required for the project.

The major parts of the project are shown with purple ovals. These are things like the grill housing and PCB that make up the bulk of the parts. However, parts like these require subparts to make them function as intended so the subparts are shown in the flowchart in orange. A subpart would be one that requires a main part to function. For example, electric burners need to be in the grill housing. Without the grill housing the electric burners would have nothing to rest on and would not be able to be heated up safely. This flow diagram helped us come with our complete parts list seen later in section 9.2.2 Bill of Materials.

9.2.2 Bill of Materials

To ensure that we stick to our budget, a bill of materials has been created in Table 9.2.2a. This table outlines every part we anticipate that we will have a need for to complete this project within our budget of \$1200. Some parts may need to be added to this list once the prototype is being tested as we discover what

works and what doesn't. It may be required that we buy additional parts as well in case something fails or does not work as expected.

Figure 9.2.1a

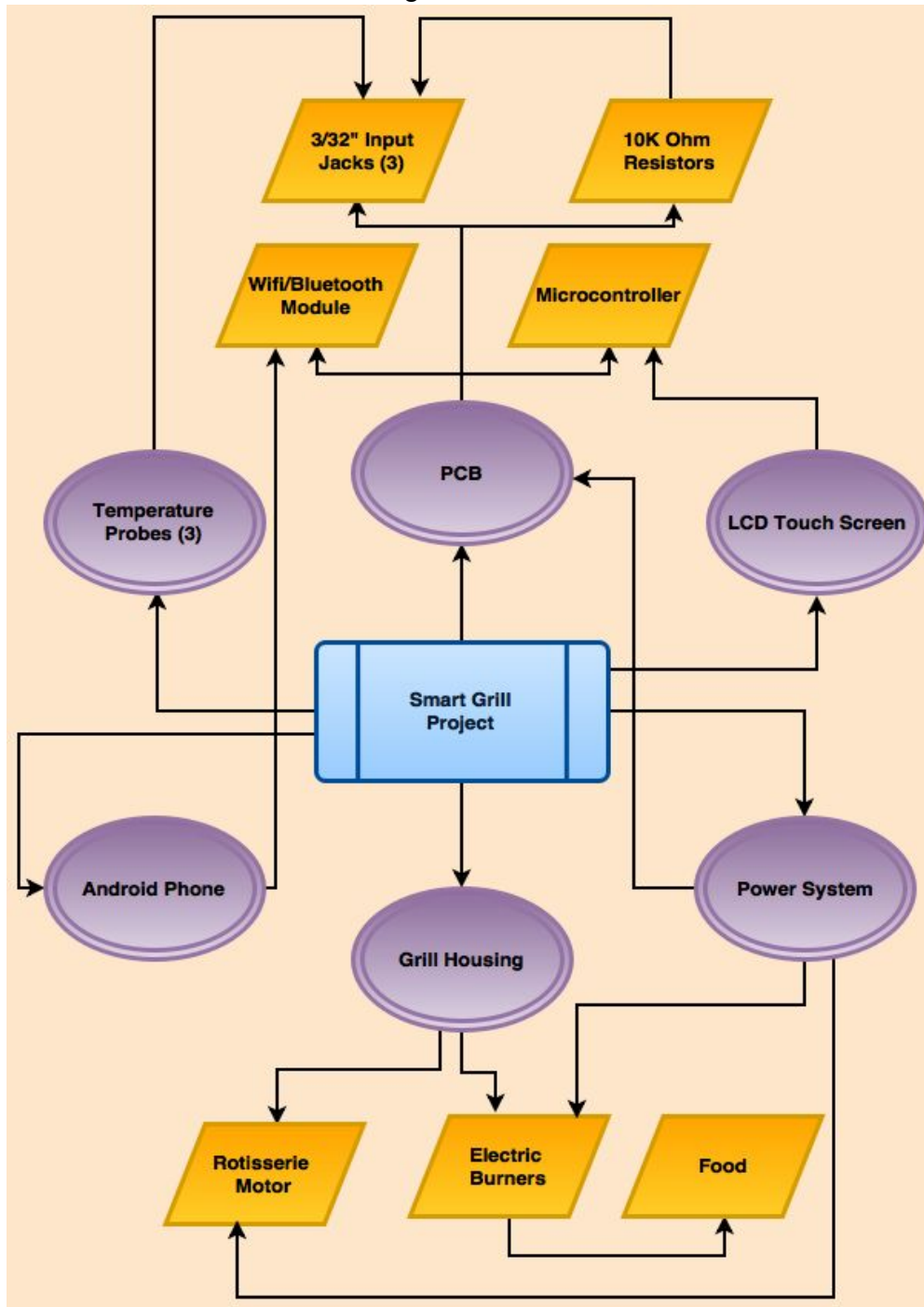

Table 9.2.2a

Part	Quantity	Price/Unit	Total Cost
Grill Housing	1	\$174.99	\$174.99
Funduino UNO	1	\$9.99	\$9.99
7" Touchscreen LCD	1	\$179.95	\$179.95
Wifi/Bluetooth Shield	1	\$24.95	\$24.95
Thermistor	3	\$10.00	\$30.00
Power System		\$1.69	\$16.40
PCB	1	\$60.00	\$60.00
10K Resistor	3	\$0.12	\$0.36
Android Phone	1	n/a	n/a
Food for Testing	10	\$5.00	\$50.00
Breadboard/Wire	1	\$20.00	\$20.00
Total Planned Expenses			\$601.49

Part	Quantity	Price/Unit	Total Cost
3/32" Connector	3	\$1.26	\$3.78
DC Barrel Power	1	\$1.96	\$1.96
22 pF Capacitor	2	\$0.17	\$0.34
16MHz Crystal	1	\$0.96	\$0.96
USB to Serial Bridge	1	\$24.95	\$24.95
0.1 mF Capacitor	1	\$0.17	\$0.17
10 uF Capacitor	1	\$0.10	\$0.10
Diode	1	\$0.44	\$0.44

9.3 Division of Labor

Since this project has a large number of components to it, we are utilizing a “Divide and Conquer” strategy to ensure that everything is able to be finished by our deadline in May. The smart grill project has been broken up into eight main components: microcontroller, mobile application, grill housing, electric grill burners, power supply, motor control, LCD touch screen, and temperature sensing.

Our design group consists four senior electrical engineering students. The members include Jeff Mueller, Thierry Alerte, Jon Graff, Jonathan Schooley. We have decided to split the research and design into 4 main parts where each group member is given an equal amount of work. Each of us will be working on separate parts of the project, however pairing up in teams of two throughout our group is likely to happen due to our conflicting schedules. We believe it is very important that each group member is completely competent in understanding the entire design of the project. Therefore, at each group meeting we explain to each group member what we have accomplished and how it works. For the purposes of this project, there are a few main stages to its creation which are universal for most products going through development. Design processes typically go through a five stage system sometimes going back and forth between the stages as needed. The five stages are: definition, research, design, prototype, and testing.

The four of us have taken two components each based on what we are most interested in and our backgrounds. This strategy will allow us to specialize on two components of the grill instead of focusing on the entire project all at once. We will need to get together to ensure that everything works properly during fabrication and testing, however during the research phase of the project, we have chosen focus most of our time on the specialties that we have chosen. Figure 9.3a is a flow chart which displays how the labor is broken up among the four of us. The purple ovals represent the eight main components of the project and the green trapezoid represents what extra work or skill will need to go into that component to ensure it functions properly for the purpose of our project. When the group originally discussed this project, there were quite a few ideas that were thrown out, as part of the design process. Originally, the group considered a touch screen interface, and after several other versions were discussed it came back to the touch screen display. The touch screen idea was originally scrapped in favor of the project not having a display screen at all. Instead, the group considered developing an application for the Android platform that would be able to view the data to control the switches on the final device. Another feature that the group would have liked to implement was a web interface that would act with the Android application, allowing the user to control and view the system from anywhere.

Figure 9.3a

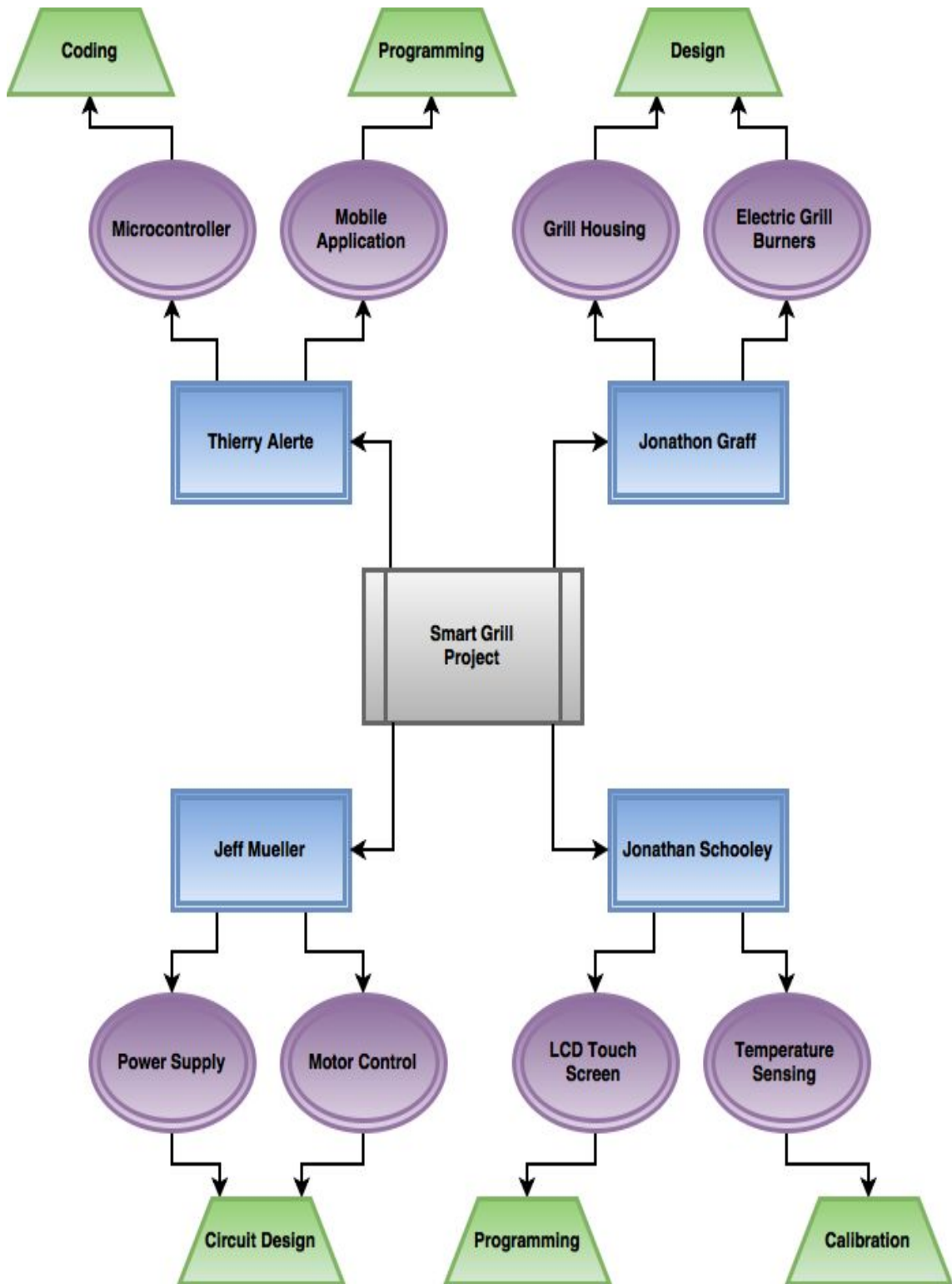

When the group originally discussed this project, there were quite a few ideas that were thrown out, as part of the design process. Originally, the group considered a touch screen interface, and after several other versions were discussed it came back to the touch screen display. The touch screen idea was originally scrapped in favor of the project not having a display screen at all. Instead, the group considered developing an application for the Android platform that would be able to view the data to control the switches on the final device. Another feature that the group would have liked to implement was a web interface that would act with the Android application, allowing the user to control and view the system from anywhere.

These two ideas were married together under the desire for user accessibility. If a homeowner had, for instance, had their parent's over for the holidays and needed more time for the grill, they would be able to use either the Android application to stay close to the family while manning the grill. This would give the user a sense of confidence that their grill is helping out with their social life. The user would be given several options of convenience to ensure that the minor investment of this product would be rewarded with major payoffs in the future.

Another feature that could have been implemented is a power smaller system. This would have allowed for more extensible use of Smart Grill as these units would be cheaper and allow for users to be more portable with Smart Grill. If this feature were adapted to the online or Android application, the user would find themselves with complete control over grilling within their life and unquestionable ability to grill easier.

In recent years, the general population is starting to grill more. As the need for awesome grills doesn't always match the growth of need awesome. It has happened in the past with anything expensive which is why a Smart Grill has sparked an interest in all kinds of people to be closer to their families and everyday lives. The carbon footprint and easy of access has pushed people to create gas grills and and now they should be pushed to rely on a Smart Grill to cook anywhere in the world from anywhere in the world.

It may not be feasible to claim that the world will eliminate their need for a smarter grill, but at some point the people will have to closely watch their grill around their children. Products like this project are going to become more ubiquitous as a way to monitor grilling usage and unwanted situations.

This project was designed to help the user grill indoors and out. The designed product will most certainly accomplish this, and will even give users the ability to monitor their grill and change settings from afar while still realizing the power consumption of your battery. Many people already do the basics – they turn the burner on when they're first want to grill, however the forget about the grill and by

that time your loved ones have already managed to be curious enough to touch or knock over the grill.

Unlike many others, this project has a battery for no wall outlet use. We also enable users the option of viewing their battery power consumption accurately simple GOOD NORMAL BAD setting like most home appliance battery gauging circuits act. It provides an easy to read and, more importantly, an easy to understand view of the power usage of the course of the grilling session.

The user can also not only see how much the time it will take before the meal is done, but can see the trends in data that saves your cookouts will inspire the user to use Smart Grill even more. Use by the outlet or a convenient battery, which can have a profound effect on the user – especially when they see no outlet nearby. Since the user will be able to see the amount the battery is consuming – the user can completely predict their daily energy usage to make Smart Grill a part in their daily activity to enjoy some tasty grilled food. With the downward economy as it currently is, the group feels that the new and current features would make the product stand out if a user was searching for a similar device.

While the device could always be improved, the group feels that the project is strong enough to stand on its own in a growing sea of competitors. The product should perform admirably well in any and all situations, and has value to anyone that uses it. Even though the grill could be made smaller and more accurate, that is something that would come from later iterations, alongside the web-based interface. The product will meet all of the standards set forth by the group, allowing the user to reduce time spent at the grill.

10 Appendices

10.3 Permissions to Use Figures

Permission to use Figure 3.3.2a and Figure 3.3.4a

Conversation started November 8



Jonathan Schooley

11/8, 4:20pm

Hello! I'm an electrical engineering major at the University of Central Florida working on my graduation project. Our team is building a smart grill that can cook food products on its own with minimal assistance from the user. For our project documentation we have to have research on temperature sensing as it will be a major component to this project. Would we be able to use some of the figures on your temperature sensing page as reference material in our research documentation paper? Appropriate credit will be given in our paper for the use of the images. Thanks for your help!



Electronics Tutorials Fan Page

11/8, 4:53pm

Hello Jonathon, as you have asked you can use some of my images for your project, but you must reference your source (www.electronicstutorials.ws) for ALL images used.



Jonathan Schooley

11/8, 7:17pm

Alright great! Thank you for your help!

Contact Us

We would like to hear from you whether you want to ask a question, receive further information, make a suggestion, share your project, or report a problem. Please contact us using the form below or sending a message to BatteryU@cadex.com with your inquiry.

Please note Battery University cannot perform calculations for projects or assignments and we do try to answer all the emails received.

First Name (required):	<input type="text" value="Jeff"/>
Last Name (required):	<input type="text" value="Mueller"/>
Email (required):	<input type="text" value="jmm07h@knights.ucf.edu"/>
Company:	<input type="text" value="UCF"/>
City:	<input type="text" value="Orlando"/>
Country:	<input type="text" value="USA"/>

Comments / Questions:

Hi, I am an EE at University of Central Florida, UCF, working on my senior design project. Our group decided to make a rotisserie grill that can be controlled on your smart phone and has temperature sensing/changing capability. I am researching the power system for this smart grill and during my research I came across one of your photos that happens to fit perfectly with the design of my smart grill.

Can I please use some of the images as well as information from this website and use it in my report. Of course I will credit you in all possible ways in my paper?
Thanks, Jeff Mueller

Please sign me up for Battery University updates (you are providing your express consent to receive electronic communications from Battery University)

SUBMIT ▶



中文 | 日本語 | [Share](#) | [MyBookmarks](#) | [MyCart](#) | [My Log](#)
Parametric Search

* Email (Confirm):	<input type="text" value="jeffmueller2012@gmail.com"/>
* First Name:	<input type="text" value="Jeff"/>
* Last Name:	<input type="text" value="Mueller"/>
Job Title:	<input type="text"/>
* Company:	<input type="text" value="UCF"/>
Division:	<input type="text"/>
Address 1:	<input type="text"/>
Address 2:	<input type="text"/>
* City:	<input type="text"/>
* North American State/Province:	<input type="text" value="Florida"/>
International State/Province:	<input type="text"/>
Zip/Postal Code:	<input type="text" value="32817"/>
* Country:	<input type="text" value="UNITED STATES"/>
* Phone:	<input type="text" value="4074357727"/>
Fax:	<input type="text"/>

* Subject:	<input type="text" value="Request Permission of website info"/>
* Describe Your Problem or Question:	<p>Hi, I am an EE at University of Central Florida, UCF, working on my senior design project. Our group decided to make a rotisserie grill that can be controlled on your smart phone and has temperature sensing/changing capability. I am researching the power system for this smart grill and during my research I came across one of your photos that happens to fit perfectly with the design of my smart grill.</p> <p>Can I please use some of the images as well as information from this website and use it in my report. Of course I will credit you in all possible ways in my paper? Thanks, Jeff Mueller</p>

[Home](#) > [Company](#) > [Website Comments](#)

Send Us Feedback

We appreciate your feedback. Please fill out and submit the form below to send us comments. For more information on our technical support form or click [here](#) to contact your local sales office for immediate support.

Feedback/Website Comments

* First Name	<input type="text" value="Jeff"/>
* Last Name	<input type="text" value="Mueller"/>
* Company/Organization	<input type="text" value="UCF"/>
* Email Address	<input type="text" value="imm07h@knights.ucf.edu"/>
Telephone	<input type="text" value="4074357727"/>
City	<input type="text" value="Orlando"/>
State	<input type="text" value="FL"/>
Country	<input type="text" value="United States"/>
* Questions/Comments	<p>Hi, I am an EE at University of Central Florida, UCF, working on my senior design project. Our group decided to make a rotisserie grill that can be controlled on your smart phone and has temperature sensing/changing capability. I am researching the power system for this smart grill and during my research I came across one of your photos that happens to fit perfectly with the design of my smart grill.</p> <p>Can I please use some of the images as well as information from this website and use it in my report. Of course I will credit you in all possible ways in my paper?</p> <p>Thanks, Jeff Mueller</p>

Submit →

Home > Contact Us > Something Else

Email Us

Send us an email. We will respond to your request in 1-2 business days.

First Name Jeff	Last Name Mueller
Email Address jmm07h@knights.ucf.edu	Confirm Email Address jmm07h@knights.ucf.edu

Select a Subject
Events and Training

Type your subject
Request Permission of website info

Email Message

Hi, I am an EE at University of Central Florida, UCF, working on my senior design project. Our group decided to make a rotisserie grill that can be controlled on your smart phone and has temperature sensing/changing capability. I am researching the power system for this smart grill and during my research I came across one of you photos that happens to fit perfectly with the design of my smart grill.

Can I please use some of the images as well as information from this website and use it in my report. Of course I will credit you in all possible ways in my paper?

Thanks, Jeff Mueller

Cancel Submit

Contact Us

(877) 388-1952

E-mail
We'll respond in 1-2 business days.

Self Service Links

- Find Training in my Area
- Access Self-Paced Online Training
- Learn about NI Certifications
- Find Events in My Area

To IA ianp...@integritynet.com.au

Cc

Request Permission of website info



Hi, I am an EE at University of Central Florida, UCF, working on my senior design project. Our group decided to make a rotisserie grill that can be controlled on your smart phone and has temperature sensing/changing capability. I am researching the power system for this smart grill and during my research I came across one of you photos that happens to fit perfectly with the design of my smart grill.

Can I please use some of the images as well as information from [this](#) website and use it in my report. Of course I will credit you in all possible ways in my paper?

Thanks, Jeff Mueller

10.4 References

- "Basic Electronics Tutorials." *Basic Electronics Tutorials*. N.p., n.d. Web. 8 Nov. 2015.
- "Electrical Principles - Chapter 8: Transformers." - *National Instruments*. N.p., n.d. Web. 10 Dec. 2015. <<http://www.ni.com/example/14452/en/>>.
- "How to Design Battery Charger Applications That Require External Microcontrollers and Related System-Level Issues." - *Application Note*. N.p., n.d. Web. 10 Dec. 2015. <<https://www.maximintegrated.com/en/app-notes/index.mvp/id/680>>.
- "Is Lithium-ion the Ideal Battery?" *Advantages & Limitations of the Lithium-ion Battery*. N.p., n.d. Web. 10 Dec. 2015. <http://batteryuniversity.com/learn/article/is_lithium_ion_the_ideal_batter>.
- "Linear vs. Switching Regulators." *Linear vs. Switching Regulators*. N.p., n.d. Web. 10 Dec. 2015. <<https://www.intersil.com/en/products/power-management/linear-vs-switching-regulators.html>>.
- "LTC2943 - Multicell Battery Gas Gauge with Temperature, Voltage and Current Measurement." - *Linear Technology*. N.p., n.d. Web. 10 Dec. 2015. <<http://www.linear.com/product/LTC2943>>.
- Lynx Grills. *SmartGrill User Manual*. N.p.: Lynx Grills, n.d. *Lynx Grills*. Web. 7 Nov. 2015.
- "Meet The iGrill Family of Thermometers." *Meet The iGrill Family of Thermometers*. iDevices, Inc., n.d. Web. 7 Nov. 2015.
- "MOSFET as a Switch - Using Power MOSFET Switching." *Basic Electronics*

Tutorials. N.p., 03 Sept. 2013. Web. 10 Dec. 2015.
<http://www.electronics-tutorials.ws/transistor/tran_7.html>.

"NFPA 96." Standard for Ventilation Control and Fire Protection of Commercial Cooking Operations. Quincy, MA: National Fire Protection Association, 2014. N. pag. PDF. 6 Dec. 2015.

"Operation of Infinite Switch." *Switches*. N.p., n.d. Web. 10 Dec. 2015.
<<http://electronics.stackexchange.com/questions/21420/operation-of-infinite-switch?answertab=votes#tab-top>>.