



**Group 14**  
**T.U.B.A-The Ultimate Bionic Arm**  
**EEL 4194: Senior Design I**  
**Final Documentation**

**Carolus Andrews**  
**Blake Steiner**  
**Raymond Brunkow**  
**Wesley Mullins**



## Biographies

**Carolus Andrews** is a former professional chef turned electrical engineer. He began back at the University of Central Florida to pursue his bachelor's degree in Electrical Engineering in 2013, and will be one of the first candidates to also graduate with a minor in Intelligent Robotic Systems. From his time in the kitchen, he has developed a strong work ethic, and desire to provide value to his customer, leading him to maintain a 4.0 UCF and Engineering GPA during his time at the university. He participated in the AUVSI 2015 RoboBoat challenge, acting as the Electrical team lead, helping the team to qualify for finals. He also serves as an engineer for Lockheed Martin's M-TADS Product Support Division through UCF's CWEP program, where he is currently leading a project to develop a new prototype piece of test equipment. In his spare time, he is an avid rugby player, and enjoys hobby electronics in the field of robotics, especially quadcopters.

**Blake Steiner** is an Electrical Engineering student here at the University of Central Florida. His education began in the Summer of 2012 at the University of Central Florida, and has been set on pursuing the field of Electrical Engineering from a very young age. He is currently working as a Reliability Engineering Intern, but his primary interest is circuit design. This project has allowed him to begin a familiarity with EAGLE CAD, and get some work in Schematic Design. Blake will graduate in Spring 2016, where he plans to work in Florida. After beginning a full time job, Blake will pursue a Master's Degree to further his education. Blake is interested in many fields, and currently works on hardware and software modifications of many electronics.

**Ray Brunkow**, Owner and chief instructor of Sun State Martial Arts from 1997 – 2008, started his trip towards becoming an electrical engineer by enrolling at Valencia College for the Fall semester 2008. Earning his Associates in Arts General Education in 2011 Mr. Brunkow took some time away from school to work as a network administrator for a network of roughly 3500 RedHat servers for individually owned and operated pharmacies across the United States of America. In the fall of 2013 Mr. Brunkow returned full time to college at the University of Central Florida as an electrical engineering student. This was also the semester that Mr. Brunkow shattered his ankle and broke his fibula with a spiral fracture that has not healed. While at the University of Central Florida Mr. Brunkow has focused his technical electives towards advanced circuit theory and power electronics with the goal of working in the power industry in either transmission or substation design and development. In early January Mr. Brunkow plans on taking the Fundamentals of Engineering (FE) exam. Upon completion of the T.U.B.A. project in the spring of 2016 Mr. Brunkow will earn his Bachelors of Science in Electrical Engineering. This is only the first step of many to a bright future as a power system engineer.

**Wesley Mullins** was born in Orlando Florida in 1993. He started working towards his Bachelor's degree in Electrical Engineering in Fall of 2012. Currently, Wesley works as a CWEP student at Lockheed Martin in the F-35 EOTS Test Engineering Department. He will be graduating with a BSEE with honors and a minor in Mathematics in Spring of 2016. After graduation, Wesley will be working full time at Lockheed Martin as a Test Engineer. He also plans to start working towards a Master's Degree in Electrical Engineering while he works at Lockheed Martin.

## Table of Contents

1. Executive Summary .....	1
2. Description .....	2
2.1. Motivation.....	2
2.2. Goals and Objectives .....	3
2.3. Design Constraints.....	4
2.4. Requirements and Specifications .....	5
2.5. Block Diagram.....	6
2.6. Integration with other research.....	8
3. Background.....	9
3.1. Current Electronics.....	11
3.1.1. Mechanical System .....	11
3.1.2. Sensing.....	12
3.1.3. Power .....	14
3.1.4. Controller .....	14
3.1.5. Servo .....	14
3.1.6. Schematic.....	15
3.2. Current Code.....	16
3.2.1. Flow Chart .....	16
3.2.2. Functions .....	17
3.3. Issues.....	18
3.3.1. Sensing.....	18
3.3.2. Power .....	19
3.3.3. Microcontroller .....	19
3.3.4. Servo .....	20
3.3.5. Software .....	20
3.4. Current Usage.....	21
4. Research.....	22
4.1. Finger Actuation Method .....	22
4.1.1. Motor Controller .....	22
4.1.1.1. Encoder Devices.....	22
4.1.1.2. Servo Motor Amplifiers.....	23
4.1.1.3. Servo Motor Controller/Motion Controller.....	23
4.1.2. Servo .....	24
4.1.3. Stepper Motor .....	26
4.1.4. Servo Signal and Power Paths .....	27
4.1.5. Motor Choice .....	28
4.2. Haptic Sensor.....	29
4.2.1. Rounded Force Sensing Resistors .....	30
4.2.2. Flex Resistors.....	32
4.2.3. Inductance to Digital Converter Sensor .....	34
4.2.4. Sensor Schematics.....	35
4.3. Haptic Driver .....	37
4.3.1. DRV2605 Specifications .....	38
4.3.2. Driver Signal Communication .....	40

4.3.3.	Integrated Waveform Library .....	41
4.3.4.	Haptic Driver Schematic .....	42
4.4.	Haptic Feedback Mechanism .....	43
4.4.1.	Linear Resonant Actuator .....	44
4.4.2.	Eccentric Rotating Mass .....	45
4.4.3.	Motor Application .....	47
4.4.4.	Feedback Constraints .....	48
4.4.5.	Mechanism Schematic.....	49
4.5.	Over-the-Air Programming Comparisons .....	50
4.5.1.	Wi-Fi .....	51
4.5.2.	Bluetooth.....	52
4.5.3.	UWB .....	53
4.5.4.	ZigBee .....	54
4.5.5.	Near Field Communication .....	55
4.6.	Over-the-Air Programming Implementation .....	56
4.6.1.	CC2560 Bluetooth.....	56
4.6.2.	RN-42 .....	60
4.6.3.	CC2650 Bluetooth.....	61
4.6.4.	Chosen Module Schematic .....	62
4.7.	Microcontroller (MCU) .....	64
4.7.1.	Voltage Regulation.....	64
4.7.2.	MSP430FR5969 .....	66
4.7.3.	ATMega328 .....	68
4.7.4.	ARM Cortex M3 .....	69
4.7.5.	ATTiny828 .....	71
4.7.6.	Chosen MCU Schematic.....	72
4.8.	Electromyography Sensor .....	76
4.8.1.	Analog Approach .....	76
4.8.1.1.	General Circuits.....	78
4.8.2.	Adding Multiple Inputs with Analog Approach .....	79
4.8.2.1.	Duplicates .....	79
4.8.2.2.	Channels .....	80
4.8.3.	Use of Programmed Digital Filter .....	81
4.8.4.	Use of Analog Front End.....	81
4.9.	Electromyography Electrodes.....	84
4.9.1.	Needle Electrodes.....	84
4.9.2.	Disposable Surface Electrodes .....	85
4.9.3.	Reusable Surface Electrodes .....	86
4.10.	Code .....	87
4.10.1.	Flowchart .....	87
4.10.2.	Libraries.....	89
4.10.3.	Functions .....	89
4.10.4.	Support Hardware .....	90
4.11.	Environmental Protection.....	91
4.11.1.	Enclosure.....	91
4.11.1.1.	Robustness to Physical Shock .....	92

4.11.1.2.	Self-Containment.....	93
4.11.2.	Electrostatic Discharge Protection.....	94
4.11.3.	Conformal Coating .....	94
4.11.3.1.	Heat Dissipation .....	95
4.12.	Integration with 3D Printed Enclosure .....	96
4.13.	Power Distribution .....	97
4.13.1.	Large signal (Motors/ Servos) .....	98
4.13.2.	Stepper Motors.....	98
4.13.3.	Stepper Motor Range of Motion .....	99
4.13.4.	Servos .....	100
4.13.5.	Small signal (ICs) .....	101
4.13.5.1.	Voltage Divider .....	101
4.13.5.2.	Voltage Regulator.....	101
4.13.5.3.	DC/DC Converter .....	102
4.14.	Charging.....	103
4.14.1.	Wireless Charging .....	103
4.14.2.	Carriage .....	106
4.14.3.	USB Charging .....	106
4.14.4.	Charging Schematic .....	110
5.	Standards.....	111
6.	Prototyping Subsections .....	112
6.1.	Power.....	112
6.1.1.	BQ500215EVM-648 Wireless Transmitter.....	112
6.1.2.	BQ51025EVM-649 Wireless Receiver.....	113
6.1.3.	BQ24120EVM-001 Li-Ion Battery Charger .....	113
6.2.	Charging .....	114
6.3.	Motor System .....	114
6.4.	Microcontroller.....	115
6.5.	Wireless Programming.....	116
6.6.	Electromyography Sensor .....	117
6.7.	Haptic Sensor and feedback .....	117
6.8.	Environmental Protection .....	118
7.	Testing .....	119
7.1.	Test Plans and Flow.....	120
7.1.1.	Power .....	121
7.1.1.1.	Phase 1 .....	121
7.1.1.2.	Phase 2.....	122
7.1.1.3.	Phase 3.....	122
7.1.2.	Charging.....	122
7.1.2.1.	BQ500125 Wireless Transmitter .....	123
7.1.2.2.	BQ510125 Wireless Receiver .....	123
7.1.2.3.	BQ24120 Li-Ion Charger .....	123
7.1.2.4.	1-8S LiPo Monitor .....	123
7.1.2.5.	2S LiPo Battery .....	123
7.1.3.	Microcontroller .....	124
7.1.4.	Wireless Programming .....	124

7.1.5. Electromyography Sensor.....	124
7.1.6. Haptic Sensor and Feedback.....	125
7.1.7. Environmental Protection.....	126
7.2. Trace Results Back to Specifications .....	127
7.2.1. Table of requirements .....	127
7.3. Required Materials .....	128
8. Final Design .....	129
8.1. Complete Schematic Footprint .....	129
8.2. Parts Acquisition and Bill of Materials.....	129
8.3. PCB Design.....	131
8.4. PCB Fabrication .....	131
8.5. Assembly Plan.....	132
9. Administrative.....	133
9.1. Milestone Chart .....	133
9.2. Budget.....	134
9.2.1. Commercial Build and Cost Plan .....	134
9.3. Consultants, Subcontractors, and Suppliers.....	136
9.4. Sponsorship .....	136
10. Conclusion .....	137
Appendix A - Acronyms .....	I
Appendix B - Permissions .....	II
Appendix C – Datasheets.....	VIII
Appendix D – References.....	IX

## Table of Figures

Figure 1: Block Diagram.....	7
Figure 2: Current Arm.....	9
Figure 3: Current Electronics.....	10
Figure 4: Current Electronics with OCB.....	10
Figure 5: Mechanical Assembly .....	11
Figure 6: Electrode Example .....	12
Figure 7: Advancer EMG Schematic# .....	13
Figure 8: Current Electronics Schematic.....	15
Figure 9: Current Code Flowchart .....	16
Figure 10: Servo Power and Signal Path Diagram.....	27
Figure 11: Haptic Feedback System .....	29
Figure 12: Layout of Rounded FSR~ .....	31
Figure 13: Flex Sensor Functionality@ .....	32
Figure 14: LDC1000 Characteristics* .....	34
Figure 15: Schematic of FSR~ .....	35
Figure 16: Schematic of Flex22 Sensor@ .....	35
Figure 17: General Usage Schematic for LDC1000* .....	36
Figure 18: DRV260 Pin Configuration* .....	39
Figure 19: Typical Usage Schematic for DRV2605* .....	42
Figure 20: Inside of the LRA+ .....	44
Figure 21: Inside of the Eccentric Rotation Mass Actuator+ .....	46
Figure 22: DRV2605 Eagle Schematic.....	49
Figure 23: FSR Schematic .....	49
Figure 24: TI's CC2560 Reference Design* .....	57
Figure 25: TI's CC2560 Reference Design Continued* .....	58
Figure 26: Logic Level Shifter Schematic* .....	59
Figure 27: BT Passive Filter Antenna Schematic* .....	61
Figure 28: CC2650 Clocks and Power Schematics* .....	62
Figure 29: CC2650 Final Schematic.....	63
Figure 30: CC2650 Bypass Capacitors .....	63
Figure 31: 3.3 V LDO Regulator .....	65
Figure 32: Switching Buck Converter* .....	66
Figure 33: CC2560 IO Schematic .....	73
Figure 34: MSP430 Connection to CC2560 .....	74
Figure 35: MSP430 Power Schematic.....	74
Figure 36: MSP430 IO Schematic.....	75
Figure 37: EMG Electrode Placement# .....	77
Figure 38: Active Bandpass Filter Schematic.....	77
Figure 39: EMG Sensor General Circuit.....	78
Figure 40: Switch Box Integration .....	80
Figure 41: ADS1293 Schematic .....	83
Figure 42: Needle Electrodes# .....	84
Figure 43: Disposable Surface Electrodes .....	85
Figure 44: Reusable Bar Electrode# .....	86



Figure 45: Flowchart for New Code .....	88
Figure 46: Shrink Wrap Diagram .....	93
Figure 47: Current Electronics Housing.....	96
Figure 48: T.U.B.A Housing Diagram .....	97
Figure 49: Power Block Diagram.....	97
Figure 50: Voltage Divider Circuit* .....	102
Figure 51: Mini-USB Connector& .....	107
Figure 52: Charge Controller Schematic&.....	108
Figure 53: MOSFET Integrated Charge Controller Design& .....	108
Figure 54: Functional Block Diagram of Charging Interface .....	110
Figure 56: CC2560 EVM Block Diagram * .....	116
Figure 57: DRV 2605 EVM* .....	118
Figure 58: Test Plan Flowchart.....	120
Figure 59: Milestone Chart .....	133

Note the following symbols indicate that the figures are reprinted with permission from:

- \* - Texas Instruments
- + - Precision Microdrives
- # - Advancer Technologies
- @ - Spectra Symbol
- ~ - Adafruit
- & - Maxim

Permissions for image reprinting are shown in Appendix B.

### List of Tables

Table 1 Requirements and Specifications .....	6
Table 2: Functions in Previous Code.....	17
Table 3: Servo Comparisons .....	25
Table 4: Servo Comparisons Continued.....	25
Table 5: FSR Characteristics vs. Force Applied .....	31
Table 6: Haptic Driver Comparisons.....	37
Table 7: ERM Waveform Effects Properties.....	41
Table 8: LRA Specifications .....	48
Table 9: Classes of Bluetooth .....	52
Table 10: MSP430FR5969 Characteristics .....	67
Table 11: ATmega 328 Characteristics .....	69
Table 12: ARM Cortex M3 Characteristics .....	70
Table 13: ATtiny828 Characteristics .....	72
Table 14: Analog Front End Devices.....	81
Table 15: Needed Functions .....	89
Table 16: Wireless Charging Interface Varieties .....	105
Table 17: Standards .....	111
Table 18: Shock Resistance Checkout.....	126
Table 19: Dirt and Debris Checkout .....	126
Table 20: Water Resistance Checkout .....	126
Table 21: Trace Back to Requirements .....	127
Table 22: Bill of Materials .....	130
Table 23: Estimated Budget .....	134
Table 24: Commercial Build and Cost Plan.....	135
Table 25: Acronyms .....	I

# 1. Executive Summary

Begun by Albert Manero in the Spring of 2014, Limbitless Solutions began as a small collective of individuals with the ethos that “no one should profit from a child in need.” Two years later, the nonprofit organization has advanced by leaps and bounds, with four directors overseeing five different teams looking to tackle the world of modern, low-cost 3D Prosthetics. As they rise to meet the ever growing demand and need for their product, they struggle to maintain their product individuality, with each prosthetic being custom tuned to the interests of each of their clients.

Given that the majority of the Limbitless leadership find their specializations in the field of mechanical engineering, they rely greatly on the expertise of the Electrical Engineering student body to continue to push the electronics of their product to its next stages of evolution, with varying degrees of success: the problem has been solved, but the solution is crude, lacking elegance, and is prone to failure. Wanting to contribute beyond the normal boundaries of volunteering, this team recommended that their capstone project be dedicated to helping Limbitless Solutions advance their electronics package to a more reproducible and reliable form, as this would allow the production team to focus their efforts in the future on the individualization of their products, rather than troubleshooting electrical problems.

This is the main goal of this paper: to research and validate working “plug and play” subsystems that Limbitless may retain at their disposal for future iterations of their design. These subsystems include Bluetooth communication, haptic feedback sensing, multiple sensor planning, and wireless charging. The idea is to ensure that each system is modular to the rest of the system, and therefore each component may be added or truncated based on the desires of the production team at the time of construction. In addition, the additional goals of electronic footprint optimization and electronics protection are also examined. The current electronic footprint is prone to malfunction given its current hobbyist configuration, with external wires and inexpensive protoboard currently being used in the fabrication process.

Ultimately, the group hopes to leave Limbitless with a complete electrical solution, with an itemized bill of materials, gerber files for printed circuit board (PCB) construction, and outsourced fabrication plans along with quoted pricing, maintaining the low total cost of construction that make their product so valuable to their target market: kids in need.

## 2. Description

This section describes in detail the motivations behind the project, as well as the outlined goals and objectives the authors of this paper hope to meet during the design phase. In addition, realistic design constraints are introduced, that will attempt to be met during the design portion of the project. In addition, engineering requirements will be introduced for each desired section, and how those sections' responsibilities will be distributed is also discussed.

### 2.1. Motivation

Limbitless Solutions has a current electronics solution for their bionic arms that is built using different boards bought from various vendors and assembled on prototyping board, illustrated in Figure 3 below. This is non-ideal from multiple standpoints, including price, footprint, reliability, and expandability. The current design has only basic functionality, as well as stability issues (due to issues such as lack of power regulation and voltage compatibilities). As such, Limbitless Solutions has asked this team to design a new set of integrated electronics that will solve problems as well as increase functionality in these areas.

The package created will serve two primary purposes. First, the electronics as they exist now are in a horrible state, due to poor voltage regulation and extra functionality and components that is not being utilized on the boards. To eliminate these issues the electronics will be unified into a single printed circuit board, electronics package that can be easily replicated for future product fabrications. Second, the additional research components will serve as a collection of various "plug and play" technologies that can be utilized in future designs. Care will be taken to ensure modularization of each section, such that if certain elements are not wanted for a specific arm, they can be easily truncated from the board. This will ensure that the solution can be used in a variety of different situations as needed by each individual client. Future compatibility will also be kept in mind during design. The team will ensure that future goals will be able to be implemented using this board. This includes having multiple EMG inputs, multiple Servo outputs, and multiple haptic feedback sensors and mechanisms. In terms of future usage the design will be updateable through plug and play expandability for the hardware components, in the case of additional units or better or more efficient hardware. For the purposes of general usage improvements, such as calibration and response time, as well as customization, only software updates will be required.

## 2.2. Goals and Objectives

In order to offer Limbitless Solutions with the ultimate bionic arm that improves upon the current design, certain goals and objects for the project were set. By setting these goals the team can ensure that an overall quality product is designed. Each of these goals set the efforts and defined the course of the project. The Goals and Objectives of the T.U.B.A are as follows:

**Maintain Design Features** - Ensure that the new set of electronics has all the same functionality as the current set up and more. At a minimum, the electronics should allow the user to control the hand by flexing a muscle on the limb with the bionic attachment.

**Unify the Electronics** - Create a PCB, or a series of PCBs to optimize the electronic footprint, and eliminate unused board space or unused functionality.

**Update the Microcontroller** - Switch to a different microcontroller that allows for expandability that is not mounted to an evaluation board. The main motivation behind this is the current solution utilizes an Adafruit evaluation board for its processing needs. This results in several components which are not utilized, but still being purchased for each arm. The new solution will seek to eliminate this wastage and only utilize components necessary for a successful solution.

**Software Improvements and Customization** - Upgrade the code and develop a calibration subroutine. This will allow the arm to be programmed for the individual.

**Integrate Feedback System** - Install a system of haptic feedback for the design. This will include a way for the user to get some sort of feedback, so that they are aware that the hand is actually closed on an object. This will add a feature that is included in expensive prosthetics, but at a lower cost.

**Environmental Protection for Electronics** - Ensure that the electronics are environmentally protected from environmental stresses. This will make the set of electronics both splash proof, dirt resistant, and shock resistant. Environmental protection will increase the reliability and lifetime of the arm.

**Protection from User Tampering** - Create a housing for the electronics that will prevent users from tampering. User interaction with the electronics can cause potential harm, and cause system malfunctioning. This will include a locking system that will only be able to be serviced by a technician at Limbitless Solutions.

**Improve Charging System** - Add charging capabilities that does not expose the charging port to environmental hazards.

**Software Updates** - Add wireless programming capability so that the electronics can be programmed without the necessity to remove the electronics from the

housing. This reduces the time in which the electronics can be exposed to environmental hazards.

Expandability and Future Improvements - Add the ability to include multiple electromyography inputs, as well as multiple haptic feedback inputs and outputs for future expansion of the design.

Affordability\_- Ensure the overall cost of the electronics solution is optimized, and remains affordable. Improve power efficiency to reduce the cost charging the battery.

Lightweight - Keep the weight of the electronics to a minimum, to ensure that arm does not feel uncomfortable.

## 2.3. Design Constraints

As detailed in Goals and Objectives above, these electronics will eventually be put in a child's bionic arm. This constrains certain aspects of the design. The weight and form factor become major parameters.

Limbitless Solutions desires the PCB for the new set of electronics to be at a maximum, the same size and weight of the current electronics. The current electronics are roughly 8.8 centimeters by 5 centimeters by 3 centimeters and 0.45 kg (including the servo, battery, and Electromyography electrodes). As such, the new electronics need to be at a maximum 8.8 centimeters by 5 centimeters by 3 centimeters and 0.45 kg (including the servo, battery, and Electromyography electrodes). This will allow the electronics to be placed in or around the child's arm without being much of an impedance to movement.

Since the electronics will be used by a child, environmental protection will be another major component of the design. This constraint is in place to ensure the longevity of the electronics.

## 2.4. Requirements and Specifications

Limbitless Solutions wants the team to ensure that the new electronics have all the same functionality as the current electronics, as well as increasing the number of features in several different areas. Limbitless Solutions current product usage is mainly geared towards children. Due to this, the group set the required weight of the arm to be approximately 0.7 kg in order to make sure that the intended child does not feel off balance. Ideally for this project the weight of the electronics will be 0.45 kg (roughly 60% of the weight of the arm) or under while keeping full functionality of the current arm.

The current standard for battery life of the arm is 6-8 hours of active usage. During this project the system will be optimized for power usage. However, due to the additional components added to the design, power consumption is expected to increase. The group will be working towards improving the power usage to allow for the additional components and sensors. Limbitless Solutions informed the team that for this project, demonstration of possible functionality is more important than battery life or weight: once they see what technologies they would like to keep from this design, Limbitless will optimize the weight and power consumption for the new design.

Currently the electronics for the arm cost between \$100 and \$150, with the addition of haptic feedback sensors and improvements to the design, the group expects the approximate cost of the arm's electronics to be under \$350.

In order to minimize potential damage to the circuit board, the group will utilize methods to ensure the board is dirt and water resistant. In the design process the group will make the design rigid enough to prevent shock damage. The one meter specification is to ensure that if a mechanical failure on the housing of the arm occurs, the resulting impact of a potential fall does not impact the performance of the electrical components.

In the event that Limbitless solutions wants to update the software running the MCU, a technician will upload the update via a wireless interface. While most wireless connections can cover a distance larger than 3 meters, the goal of the board is to allow a technician to send the updates through a computer located within the same room. A large coverage would not be necessary for this purpose.

Currently the battery for the bionic arm is charged at night, while the child is asleep. For this reason the group has set the charge time requirement to be less than 8 hours in order to make sure that the device will be fully charged after sleeping, where they can continue usage throughout the day or charge when not in use. A summary of these features is listed in Table 1.

Description	Quantifiable Specification
Electronics Weight	Less than 0.45 kg for kids, 1.4 kg for Veterans
Battery Life	10 Hours Standard Usage
Price (wholesale)	Under \$350 for the overall design
Environmental Protection	At least IP27
Wireless Programmable Range	Minimum of 3 meters
Charge Time From Entirely Drained Battery	Less than 8 Hours

Table 1 Requirements and Specifications

## 2.5. Block Diagram

This block diagram illustrates the electronics of the design, as well as the inputs and outputs of each block. In the design and fabrication of this project the tasks were broken down into four main groups. Each set of tasks were set to a corresponding group member shown by the legend table on the block diagram. Raymond Brunkow is in charge of the system's power supply and motor. Wesley Mullins is in charge of the EMG sensing applications. Blake Steiner is responsible for the Haptic Feedback component of the system. Carolus Andrews is in charge of the microcontroller and "over-the-air" programming functionality.

Each set of tasks will be researched and performed by the corresponding member of the group, but each task will be evaluated and integrated through the support of the team.



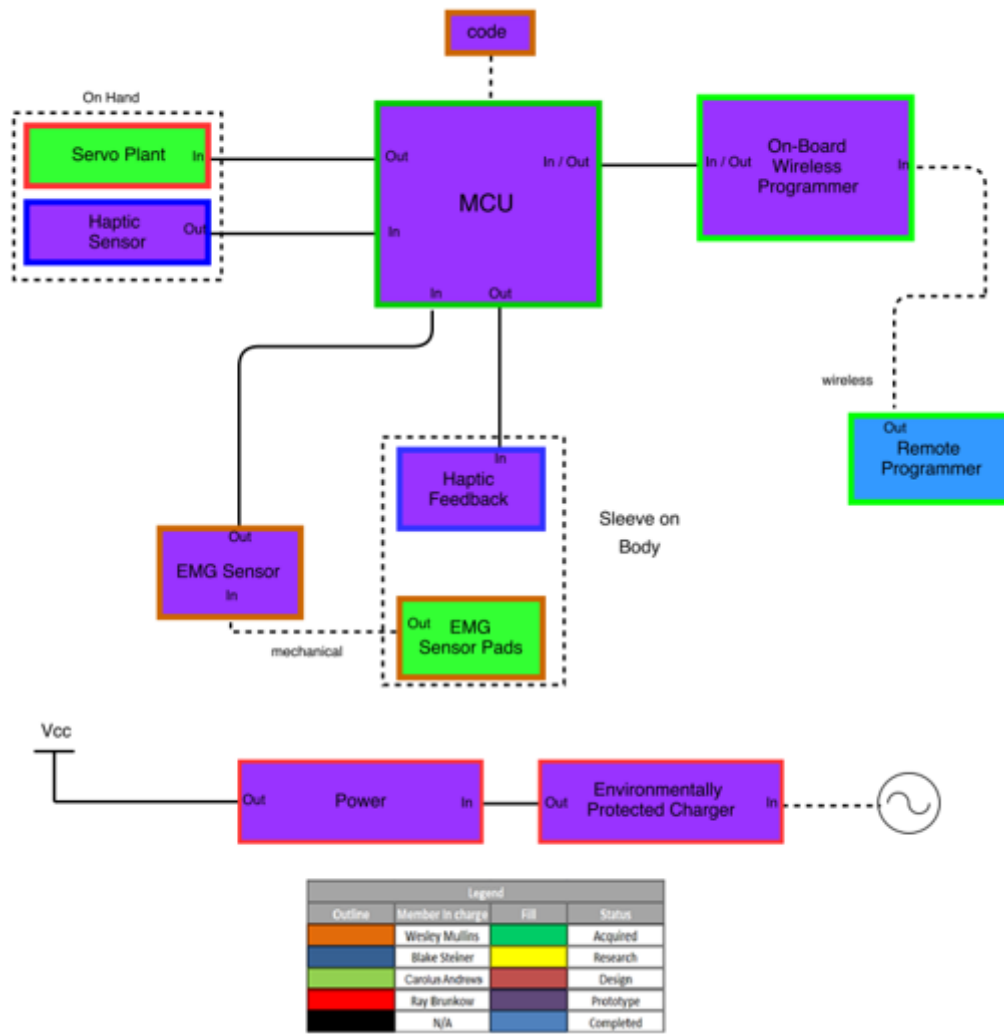

Figure 1: Block Diagram

## 2.6. Integration with other research

During the course of Senior Design I, Limbitless Solutions has also sponsored another team to design the arm to have multiple muscle sensor inputs and individual finger movement. This design requires multiple EMG sensors and individual servos. In preparation of the possibility of integrating the multiple finger movement, the group will select a microcontroller that features additional pins to provide support in the future.

This design for this project will allow for the possibility of integrating the design of the other group, during the course of Senior Design II or in the near future. This will be realized by choosing an MCU that features additional General Purpose Input and Output (GPIO) pins for expandability of the design. The ultimate goal is to provide Limbitless Solutions with the tools to enrich the lives of those who need the arm.

Further research and usage of other applications could make the arm smarter and add additional functionality. The aim of this project at its current point is to design a low cost, robust, and power efficient design while meeting the specifications and requirements set by Limbitless Solutions. The technology for this design will always have possibilities for improvement in the future. By providing Limbitless Solutions with this design the group will be providing the The Ultimate Bionic Arm and the ability to easily redesign it when improvements can be made.

### 3. Background

Limbitless Solutions currently has a set of electronics that minimally meets their needs and is extraordinarily unstable. Below, the current state will be extensively discussed. This will give a good starting point for the discussion of what needs to be improved upon.

For reference, below are two versions of the current electronics. Figure 2 shows the most frequently used style. There is no use of breadboards, protoboards, or printed circuit boards. Instead, jumper wires are used throughout to connect the different modules.

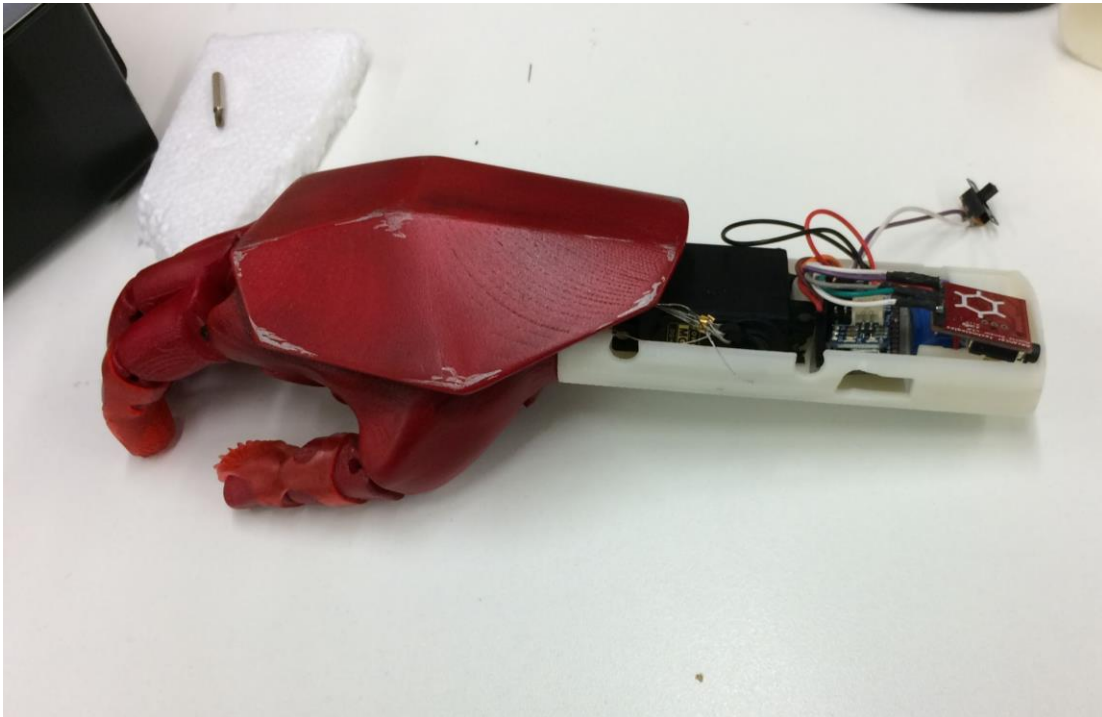

Figure 2: Current Arm

Figure 3 shows a newer version of the electronics that uses protoboard to simplify the wiring. The electronics still have the same amount of jumper wires, but they are all soldered in place to increase reliability.



## 3.1. Current Electronics

As stated above, the current set of electronics that Limbitless Solutions is using is not only inadequately designed, but tend to be built in such a way that they break very quickly and easily.

In this section, the theory behind the current build of the electronics will be discussed in order to give a foundation for understanding why each module was selected. The schematic will be shown to give a better idea of the details of how the modules are connected together. Finally, the Hardware Issues will be discussed.

### 3.1.1. Mechanical System

The senior design team will not be altering the mechanical design, but rather designing the electronics to work with the current system. The present design has flexible joints in the fingers that are the consistency of rubber. These force the hand into an open position naturally. It takes force to pull the hand closed and it will spring back open when the force is no longer applied. The fingers have wires running through them which pass down to the servo to pull the hand closed. See Figure 5 below.

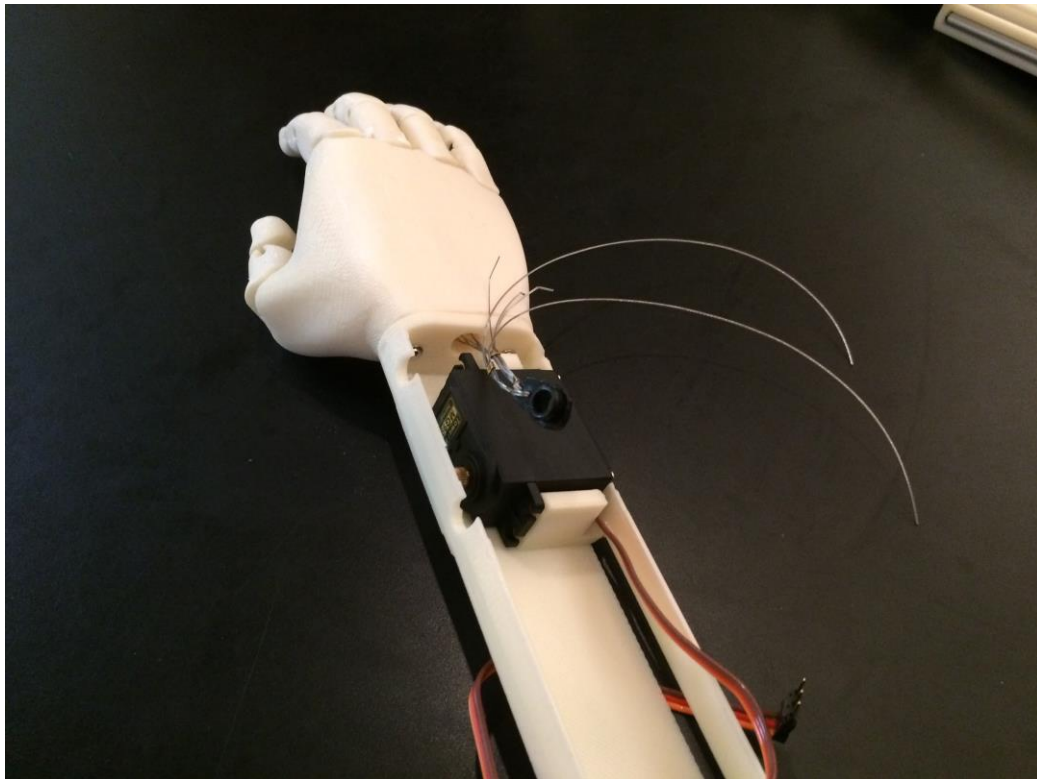

Figure 5: Mechanical Assembly

The electronics housing (the forearm section of the bionic limb) will likely be altered to accept the footprint of the new electronics, servo, and battery, but the hand and wires will remain similar to the present design.

### 3.1.2. Sensing

The current electronics work primarily off of Electromyography (Electromyography circuits will be discussed in detail later). When the electromyography sensor senses a muscle is flexed, the software triggers the hand to toggle states.

The sensor module is the *Muscle Sensor v3* from *Advancer Technologies*. This Electromyography sensor generates an analog voltage that is proportional to the amount the muscle it is attached to flexes. In testing the arm, this sensor was seen to be very reliable and even has an adjustable gain potentiometer so the output can be tweaked to compensate for day-to-day changes in muscle behavior. The sensor is attached to the user by medical electrodes (The same kind used for EKG or ECG tests. pictured below in Figure 6

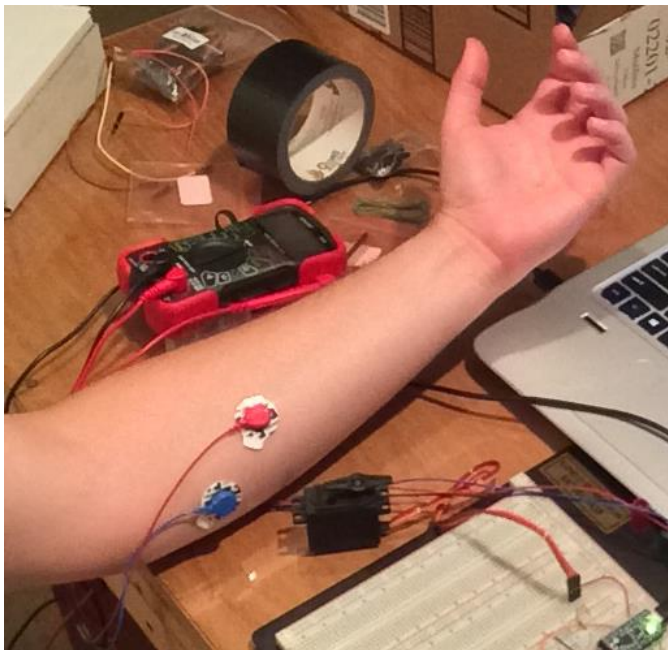

Figure 6: Electrode Example

The Electromyography sensor from *Advancer Technologies* uses the circuit in Figure 7 to filter and amplify the raw signal from the muscles.

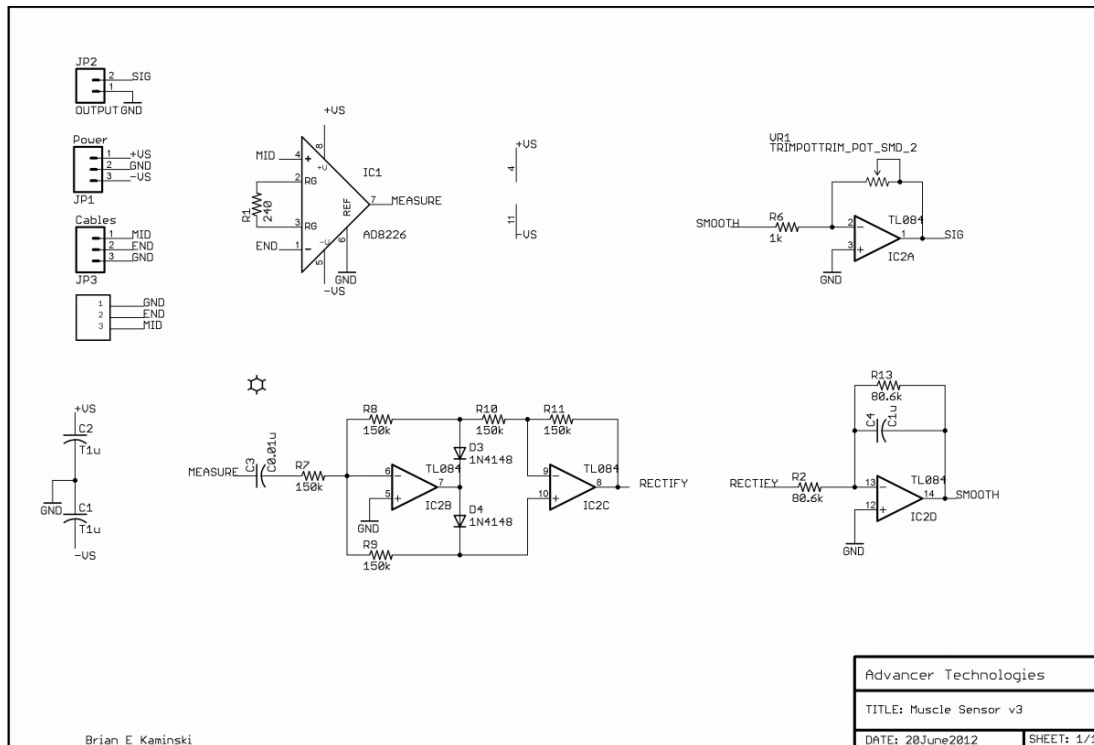

Figure 7: Advancer EMG Schematic#

This circuit uses an instrumentation amplifier (AD82226) to amplify the raw signal from the muscle. This is a decent selection as it has very low Common Mode Rejection Ration (CMRR) and allows for sufficient gain to the signal.

The Electromyography module then uses a full wave rectifier (using two Operational Amplifiers and two diodes) to rectify the signal. The half wave rectifier circuit used has very low noise and is almost as close to an ideal half wave rectifier as a circuit can be using real components. The Operational Amplifier used is the TL084.

Next, the Electromyography module filters the signal. A low pass filter is used as an envelope detector. This will reduce much of the high frequency noise in the circuit and bring the signal much closer to a purely DC, Binary signal (which is what is wanted to communicate with the microcontroller). The circuit uses another Operational Amplifier from the TL084.

Finally, the circuit has an inverting amplifier with an adjustable gain. This makes the signal positive (the low pass filter inverted the signal) and allows the user to increase or decrease the magnitude as needed.

### 3.1.3. Power

The electronics are powered by a 3.7 volt, 2000 milliamp-hour Lithium Ion battery. Feedback from users indicates that this gives around 5-8 hours of usage.

Since this battery is a rechargeable Lithium battery, precautions have to be taken when charging or discharging it. Charging the battery too quickly, charging the battery to too high a voltage, or discharging the battery too far below 3.7 V can reduce longevity of the battery or in some cases cause the battery to catch on fire or even explode. As such, Limbitless Solutions uses the *Adafruit Pro Trinket Lilon/LiPoly Backpack Add-On*. This module ensures that the battery is charged at a safe rate (maximum of 100 milliamps) and only to a maximum of about 4.2 volts. It also has under voltage protection that stops discharging the battery when the battery voltage drops below 3.7 volts.

This module is crucial for safe usage. Care will be taken to ensure this capability is kept in the new design.

The Advancer Technologies *Muscle Sensor v3* requires both a positive and a negative voltage to operate properly. To avoid using two different batteries, Limbitless Solutions uses an ICL7660 Voltage converter. This takes in a positive voltage and outputs a negative voltage of about the same magnitude. This requires the design to feature an inverter adding to the number of electronics, and taking board space.

### 3.1.4. Controller

Limbitless Solutions is using the 5 volt *Adafruit Pro Trinket* for the microcontroller in their design. This runs off of an ATmega328P chip. Seeing as the current design is essentially a T-flip flop with an analog input, this is more than enough to support the code. The *Adafruit Pro Trinket* also has some very useful peripherals; it has an on board linear voltage regulator, Micro-USB jack (for use during charging and programming), power indicator LEDs, and a reset button.

### 3.1.5. Servo

The current servo is the *Tower Pro MG995*. This servo can produce more than enough torque to effectively close the hand and grasp most objects (roughly 0.85 Newton Meters). It is controlled by Pulse Width Modulation (PWM) with a 20 millisecond period (or a frequency of 50 hertz). It is supposed to operate at roughly 4.8 to 7.2 Volts.



### 3.1.6. Schematic

Figure 8 below details the general schematic that Limbitless Solutions is currently using. All the headers connect to the auxiliary modules that are used for the Electromyography sensor, Microcontroller, and the like.

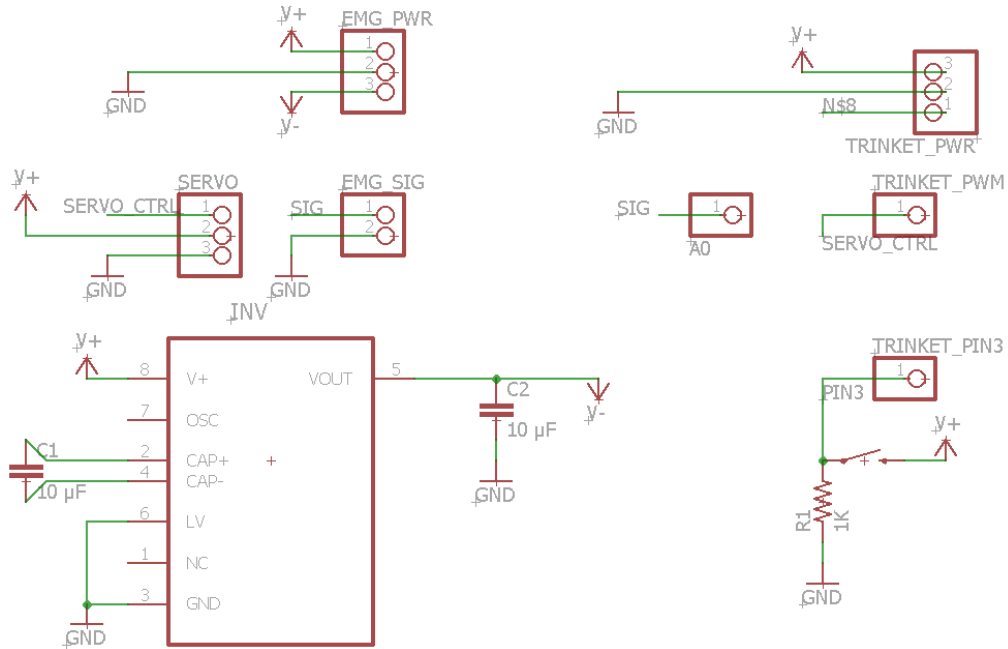

Figure 8: Current Electronics Schematic

## 3.2. Current Code

The code that is presently in the arm is extremely limited in function. As stated earlier, it is essentially a T-flip flop. The *Adafruit Trinket Pro* is built to run the same as an *Arduino Uno*. As such, the Limbitless Solutions uses the *Arduino Integrated Development Environment (IDE)* to program the microcontroller. This makes the code very readable and is great for beginners, but it severely limits the available functionality of the microcontroller.

### 3.2.1. Flow Chart

Figure 9 below is a simplified flowchart of the current software.

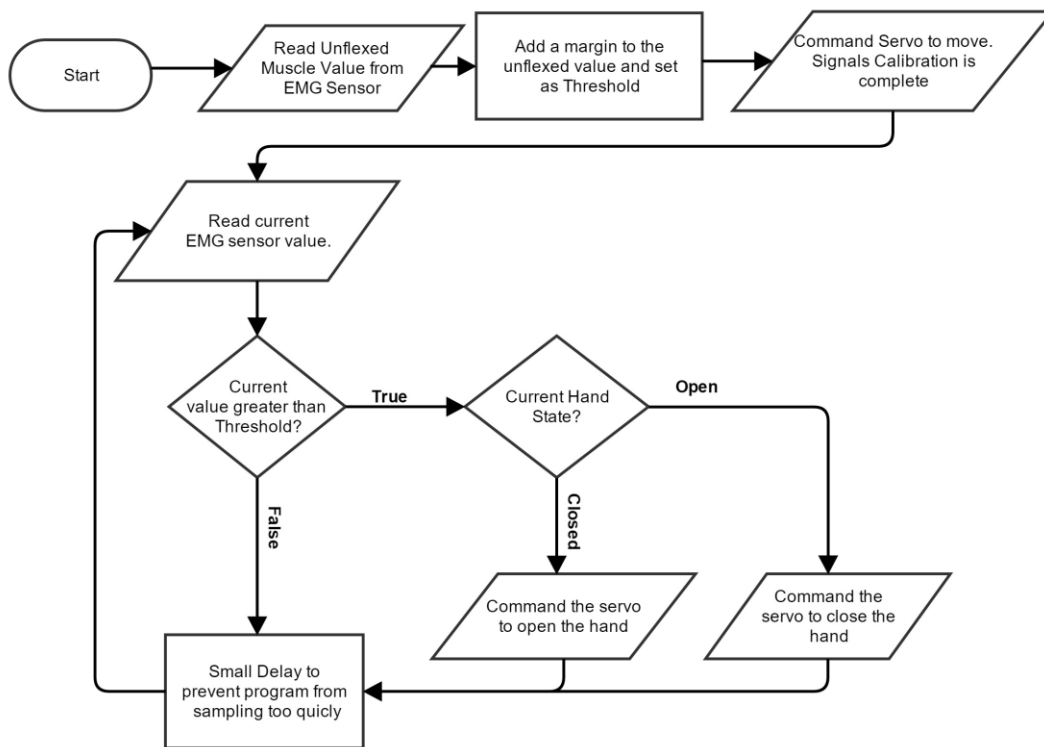

Figure 9: Current Code Flowchart

### 3.2.2. Functions

Table 2 below shows all of the functions currently in the code.

<b>Function</b>	<b>Description</b>
Attach	Sets up the Pulse Width Modulation pin to control the servo.
Write	Takes in an angle in degrees and commands the servo to move to that angle.
Setup	Runs only once before the main program runs. This is used to configure all the pins and values. The calibration routine is run within this function.
Loop	This function loops continuously. It contains the routines to check if the current sampling value is greater than the threshold value and commands the servo accordingly.

Table 2: Functions in Previous Code

It is evident that the code has few functions. All the routines are executed in the setup or main loop rather than being broken out into separate functions to be called.

### 3.3. Issues

Limbless Solutions admits that the current electronics have many flaws that can be improved upon. Most of the arms they have given out have electronics that are so unstable, they can only be used for about an hour on a completely full charge before they start malfunctioning.

Much testing has been done on the current setup to get a good idea of what issues there are before the team starts to make changes. Each component of the hardware was isolated and analyzed to determine what issues were present. The same was done with the software: Each major block in the flowchart was isolated and tested.

#### 3.3.1. Sensing

The Electromyography sensor works extremely well for the purposes of this project. It produces a relatively clean signal and does not consume much power.

One drawback is that it only allows for a single input. As such, the only way to add more inputs is to add more boards. It is a relatively large board (roughly 2.5 centimeters by 2.5 centimeters) and therefore adding more is not a possibility given the size constraints. This severely restricts the current as well as future functionality in the arm.

The sensor also uses a 2.5 millimeter audio jack as for the sensor pad cable. This is nice because it is a very common connector, but is very large and could be improved upon.

Finally, the sensor pads themselves are not adequate. They produce a decent signal, but each pad may only be used once, as they are held in place with relatively cheap adhesive. As such, a user would have to have roughly 81 pads a month to use it every day (3 pads a day for 7 days a week for 4 weeks). Reusable pads already exist, and would be much better than the ones currently in use.

### 3.3.2. Power

The power regulation in this system is entirely inadequate. The only thing that is regulated is the microcontroller itself. Everything else currently runs solely off of battery power. This means that any spikes or drops in the voltage currently will directly influence everything except the microcontroller. The electronics are therefore very sensitive to the battery running low on charge. This is problematic for ensuring maximum battery life in the product, and research will be focused on finding a better regulation scheme for the overall system.

The current battery is only 3.7 Volts and there is no boost converter. As such, the servo is powered by an underrated 3.7 volts, instead of the 5 to 7.5 Volts it was designed for. This equates to the servo moving significantly slower than it could, and it has much less torque than it is capable of producing. As such, the servo is very underutilized. Seeing as Limbitless Solutions wants the hand to actuate faster, this is an issue that needs to be addressed.

### 3.3.3. Microcontroller

The *Adafruit Trinket Pro* is a very decent and capable evaluation board, containing, in addition to other peripherals, an ATTiny828 microcontroller. When programmed in its assembly language or a compiler other than the Arduino IDE, it has a lot of functionality. But when programmed by the Arduino IDE, it is very limited in its functionality. It only allows one pin to be used as an interrupt and can't control many servos from its pulse width modulation pins.

The Integrated Circuit itself has a very small form factor. But the *Adafruit Trinket Pro* is built to be used with other through-hole components and so has 0.1 inch headers built in. This makes the board much larger than is needed for this project.

The module also has a built in linear voltage regulator that is very useful. It ensures the microcontroller gets the correct voltage as long as the input voltage is high enough. It also has built in circuitry to allow it to communicate directly with a USB port on a computer for programming. This is a great feature considering most microcontrollers in this size require external FET emulators or FTDI boards.

### 3.3.4. Servo

The *Tower Pro MG995* is a very strong servo for its size but it is heavier than other servos in its class. As discussed earlier, it is weaker than advertised due to the current configuration running it at lower voltage than suggested.

The servo is also not isolated from the rest of the power distribution. This means that if the servo spikes or drops, these variations are passed directly to the rest of the components in the system. From testing, when the servo is powered at 3.7 Volts, the servo produces a voltage drop to around 2 volts and can spike up to 9 volts.

### 3.3.5. Software

As discussed earlier, the software is very limited. It functions mostly as a toggle switch. The calibration routine that is built into the software is not as powerful as it could be. It needs to be run every single time the microcontroller is powered on. Seeing as the *Adafruit Trinket Pro* has a fair amount of EEPROM (Electrically Erasable and Programmable Read Only Memory), the threshold value from the calibration routine can be stored in nonvolatile memory. This will save the user a lot of time. The calibration routine logic is also not sound. It adds some constant to the un-flexed value from the electromyography sensor. The amount that should be added will vary greatly for each user. A better method would be to measure the flexed value and then set the threshold to be 50-75% of the flexed value.

### 3.4. Current Usage

Currently, the arms vary in quality depending on the time of production. Depending on the skill of the person building the electronics, the quality can change drastically. As such, Limbitless Solutions would like to source the soldering to a professional company. This will ensure consistent quality and will greatly increase the reliability of the product. However, much of this variance is due to the current design of their electronics package. The hobbyist design with wiring stretched across the back of protoboard is in itself an unsound practice, and design of a PCB that allows for pick and place of electronic components could potentially simplify this process for them. The tradeoff from this is that the addition of surface mounted components could also introduce additional soldering challenges, depending on the pitch and proximity of the surface mounted pins.

The varying reliability and poor calibration routine acts as a barrier to use for some children. Since the electronics will sometimes stop working for no seeming reason and the electronics need to go through a roughly one minute calibration every time they are turned on, children tend to lose interest.

It has also been observed that some children actuate the arm much more than needed. Some children enjoy seeing the hand move or like to show it off a lot. This means that the battery life is significantly reduced for children like this. This presents an interesting design challenge as it is difficult to define how many actuations are typical per unit time (for example, closing the hand 20 times per hour or 100 times per hour).

## 4. Research

The project itself is divided into several sets of components. These include the battery, servo, microcontroller, communication interface, haptics system, charging mechanism, and EMG interface. Research was performed on these concepts in order to determine the best methods of achieving the requirements set within section 2. The research as well as the methodology for determining the best course for the design is presented in the sections hereunder.

### 4.1. Finger Actuation Method

The mechanical engineers within Limbitless Solutions have created a 3D printed hand for their original design. Cables are tied to the inside of the 3D printed fingers of the hand. For the design of the T.U.B.A, the torque of the motor will pull on cables tied to the 3D printed finger mechanisms. The resulting pulling of cables will cause each finger to curl towards the palm of the hand, forcing the hand to close. A large portion of the project is determining the best method to accomplish this action. This actuation can be powered by varying types of motors. The research behind the chosen motor is shown in throughout Section 4.1.

#### 4.1.1. Motor Controller

Servos require external motor controller's in order be properly positioned as well as to hold a specific position about its rotation on the axis. There are several external devices required for servos to function properly. Many servos have a few of these elements built into them making their management much simpler.

##### 4.1.1.1. Encoder Devices

The encoder is a position sensor for monitoring the angular position as well as velocity of the rotor. This is also used for linear servos. Linear servo motors will not be discussed for this project. Many servos have built in encoders. It is possible to use an external encoder. With an external encoder in use it is very important that there is limited time delay between the encoder and the motor.

The use of an external encoder for the T.U.B.A. is not desirable due to the delay that could be caused by the cabling to manipulate the fingers potentially stretching and not providing instant feedback to the encoder of the motors position and velocity. For this reason an internal encoder will be used with the design.

For larger projects, perhaps the adult arm with multiple servos, multiple positions, and more the use of two encoders might be a viable option. By pairing the internal encoder with the external encoder at the load, fingers for example, a more complicated configuration provides greater detail of the actual velocity and position of the motor in relationship to the load. For now this is beyond the scope of the T.U.B.A. project.



### 4.1.1.2. Servo Motor Amplifiers

A typical servo motor amplifier is exactly what it sounds like. The servo motor amplifier takes the input signal and increases the current to produce larger amount of torque, or to produce a specific amount of torque. This is not the only type of servo motor amplifier but for the T.U.B.A. project it is considered as potential option in order to obtain the requirements of the client. For rotary servo motors the torque is directly proportional to current. Therefore the servo motor amplifier would be directly controlling the amount of torque produced by the servo motor.

### 4.1.1.3. Servo Motor Controller/Motion Controller

The encoder and servo motor amplifier are open loop elements that receive a signal and output another form of the signal. The servo motor controller's job is to close the loop by constantly monitoring the signal from the encoder and applying torque to the motor to control its position. Servo motor controllers are often referred to as motion controllers. This is a far more accurate nomenclature than servo motor controller. For example, if the rotor on the servo moves from its desired, or current, location a signal is sent from the encoder generating an error in the motion controller. With the closed loop system the motion controller will send the torque signal in an attempt to return the rotor to the desired location. This will continue until there is no error signal from the encoder, or when the error signal falls below any preset accepted norms.

It is this type of closed loop feedback system that causes servos to constantly consume power and to have the twitching motion discussed in section 4.1.1. The motion controller typically will use pulse width modulation to drive the rotor clockwise or anticlockwise as is desired for holding position or moving to a new position.

## 4.1.2. Servo

For servos and steppers motors the team has the same requirements.

1. No less than 0.85 Nm torque is required to close the fingers of the current design.
2. The ability to fully rotate under 0.4 seconds.
3. If possible reduced size.
4. Upgrade from plastic to metal gearing.
5. Operate in the 4 – 7.2 volt range.

The two following tables, 3 and 4, list several of the candidate's with their respective specifications and rough cost per item. All of the following servos have metal gears in order to make it onto the list of potential devices for the T.U.B.A.

From the list below, the MG995 servo, highlighted, is not only the least expensive metal gear servo, but has among the highest torque as well as the fastest rotational speed through 60 degrees over the 6.0 volt range. Limbitless Solutions will manage the gear ratio to increase the range of motion required for their application and the manipulation of the finger joints. Each of the following servos are superior in speed and torque when compared with the current servo in use. The HPI SF-50WP is the most expensive and does cost more than the current servo in use. It is also the slowest of the listed devices making it the least desirable device for the T.U.B.A. application. The TMAXX 3.3, TAMIYA, and the TRAXXAS 2055 are all comparable with each other and will make great optional devices if the MG995 is unavailable for future use.

	<b>MG995</b>	<b>TMAXX 3.3</b>	<b>TAMIYA</b>
Dimensions mm	40.6x19.8x37.8	40x19x43	40x19x43
Operating Speed 4.8V	N/A	0.17sec/60 deg	0.17sec/60 deg
Operating Speed 6V	0.13sec/60 deg	0.13sec/60 deg	0.13sec/60 deg
Stall Torque 4.8V	N/A	1.27 Nm	1.27 Nm
Stall Torque 6V	1.47 Nm	1.56 Nm	1.56 Nm
Operating Voltage	4.8 – 7.2V	4.8 – 7.2V	4.8 – 7.2V
Price \$	6.90 + s/h	16.85 + s/h	16.99 + s/h

Table 3: Servo Comparisons

	<b>TRAXXAS 2055</b>	<b>HPI SF-50WP</b>
Dimensions mm	40.7x19.7x42.9	30.9x21.x29
Operating Speed 4.8V	0.17sec/60 deg	N/A
Operating Speed 6V	0.14sec/60 deg	0.18sec/60 deg
Stall Torque 4.8V	0.92 Nm	N/A
Stall Torque 6V	1.07 Nm	1.17 Nm
Operating Voltage	4.8 – 7.2V	4.8 – 6.0V
Price \$	19.00 + s/h	32.29 + s/h

Table 4: Servo Comparisons Continued

### 4.1.3. Stepper Motor

For servos and steppers motors the team has the same requirements.

1. No less than 0.85 Nm torque is required to close the fingers of the current design.
2. The ability to fully rotate under 0.4 seconds.
3. If possible reduced size.
4. Upgrade from plastic to metal gearing.
5. Operate in the 4 – 7.2 volt range.

This is caused by the proportionality of the winding current and the turns of the wire for each pole. A direct one to one ratio, under ideal conditions, indicates that a 20% increase in current is a direct 20% increase of torque. This rule is close enough for rough calculations to hold. That is true up to about two times the rated current, at this point it can be seen that little if any improvement on the torque output and worse it drastically increase the risk of damage to the motor. Neither are desirable effects.

At higher angular velocities the torque of the stepper motors drops off significantly due to self-inductance of the windings. Each motor has a built in self-inductance that cannot be overcome. As a direct result a motor that has both high torque at low revolutions per minute, but also a low enough self-inductance to still produce high torque in the upper RPM band for the motor must be found.

Even with high inductance when stepper motors are run at low revolutions per minute this is not an issue as the current can easily flow into the motors windings fast enough that the stepper motor is capable of reaching its rated torque. Conversely at higher revolutions per minute the current is prevented from flowing due to the high inductance causing a loss of torque. Motors that are capable of producing high RPMs while still being able to deliver rated or near rated torque only operate in the 24V or higher category of stepper motors.

The T.U.B.A. project will not be functioning outside of the 7.4V range, thus steppers motors have been removed from consideration.

#### 4.1.4. Servo Signal and Power Paths

The data flow for the servo motor system is through the battery, charger, and protection units: BQ771605 Monitor, BQ24123 Charger, into the DC/DC Converter (TPS65252) where the voltage is split into the 3.3 V rail for the integrated circuits and the microprocessor unit., and the 6.0 V rail sent directly to the servo motor.

The microprocessor unit will control the pulse width modulation required to drive the rotor for the servo brushless motor of the MG995. Figure 10 below shows the basic flow for the power.

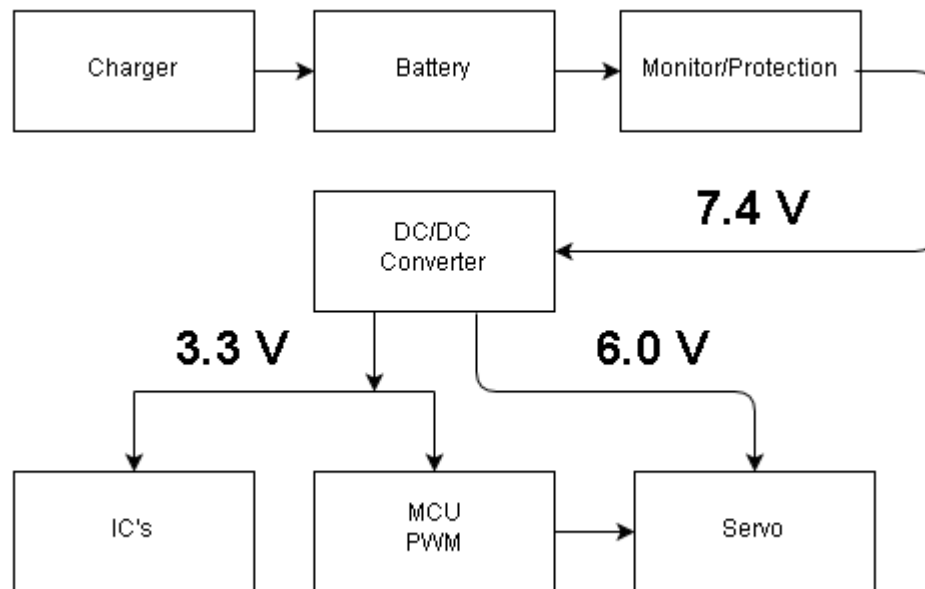

Figure 10: Servo Power and Signal Path Diagram

## 4.1.5. Motor Choice

For servos and steppers motors the team has the same requirements.

1. No less than 0.85 Nm torque is required to close the fingers of the current design.
2. The ability to fully rotate under 0.4 seconds.
3. If possible reduced size.
4. Upgrade from plastic to metal gearing.
5. Operate in the 4 – 7.2 volt range.

Following the above metric for choosing the motor for the T.U.B.A project, stepper motors are discounted unless the arm is upgraded to run 24 V power supply. That is far outside of what the client desires to remove stepper motors from the equation.

Looking at the chosen servo motors comparing price, performance, size, and power (torque provided) staying with the MG955 appears to be the best option for T.U.B.A.

## 4.2. Haptic Sensor

For the new Limbitless Solutions Bionic Arm, the group has been tasked with enabling a feature that will allow the user to have a sense of feeling when the arm is being utilized. This feature is important in order to let the user interpret or feel the arm as it operates. The arm currently allows the customer to pick up an object based on the flex of their muscle, but provides no form of feedback to show that the arm has been closed after it performs its task. Feedback for this purpose, provides the user with the ability to feel the arm in action, and make the interface more realistic for the user. This type of feedback will ensure the user that the arm is functionally operating through a real-time response. By incorporating this feedback, the group will be adding more functionality to the bionic arm and allow the user to truly feel the arm as if it were their own. A flowchart for the haptic feedback system is shown in Figure 11 below.

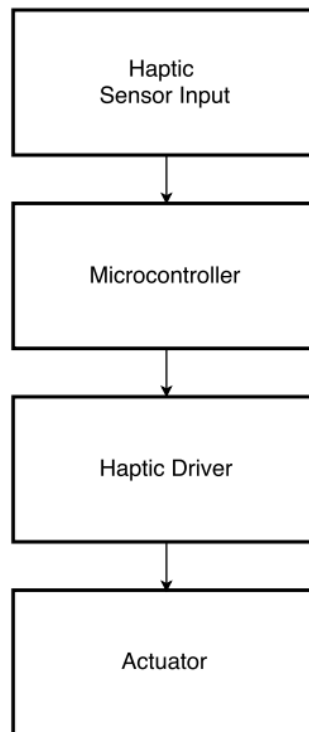

Figure 11: Haptic Feedback System

In order to enable haptic feedback on the system, the arm must be able to sense when the hand is being closed or touching an object. The sensors that are able to interpret this input are force sensitive resistors (FSR) and the Inductance to Digital Converter. Force sensitive resistors typically come in two varieties of shape. While each resistor has the same basic functionality, the shape is important to denote for space constraints as well as usage experience. The type that will be considered for the project is described in subsection 4.2.1 below. The schematics are captured in section 4.4.4.

## 4.2.1. Rounded Force Sensing Resistors

Of the varying types of force and pressure sensing resistors, the ones whose footprint best fits this project, is the rounded force sensing resistor. The way that this resistor works is that the user of the arm will apply pressure when the hand is closed. Applying this pressure to the resistor will change its resistance. When no pressure is applied the FSR's resistance is infinite, causing the component to act as an open circuit.

There are two connections to this FSR. One is the input voltage, and the second is the output line for the signal to the MCU. This resistor is like normal resistors in the regard that it is non-polarized, and either line functions the same. When the resistor acts as an open circuit, there will be no output to the MCU. At this point, the haptic motors will be powered down and drawing no current as the microcontroller has not signaled an output response to the driver powering the motors. As more force is applied to the resistor, the resistance will decrease from infinity. Based on the specifications set for the resistor, this resistance will change with the amount of force applied to a predetermined set of values, indicated by the table below. The applied voltage for the FSR in this scenario is 5V. As shown in the schematic in section 4.4.4, the force sensitive resistor is combined with another resistor. The purpose of this resistor, R, is used to customize the force sensitivity range. The equation for measuring the output voltage is shown by the equation:

$$V_{out} = V_{in} * \frac{R}{R + FSR}$$

For the data collected the value of R was 10kΩ.

Force sensitive resistors are accurate enough to determine when pressure of a range of magnitude is applied. The sensing will not be exact, but the specified range of the expected result from holding an object can be coded to be recognized by the microcontroller. Since the hand will not be directly touching the palm of the hand at all times, the FSR must be mounted onto the finger where the most contact with the object will be. The mounting of the FSR can vary based on the location of the placement. The FSR described here in table 5 and shown in Figure 12 has a diameter 0.7 inches, but since the size for the hand varies per child a different FSR can be utilized that will fit the mounting surface depending on the placement of the resistor. Sparkfun offers a similar product that is only 0.3 inches in width, which would be ideal to fit on the surface of a finger. The functionality of this smaller resistor will be the same as the one described above and will share similar properties with the measured values in Table 5.



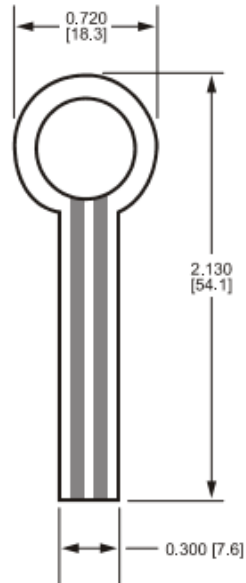

Figure 12: Layout of Rounded FSR~

Force (lb)	Force (N)	FSR Resistance (kΩ)	(FSR + R) KΩ	Current thru FSR+R (mA)	Voltage across R (V)
None	None	Infinite	Infinite	0	0
0.04	0.2	30	40	0.13	1.3
0.22	1	6	16	0.31	3.1
2.2	10	1	11	0.45	4.5
22	100	0.250	10.25	0.49	4.9

Table 5: FSR Characteristics vs. Force Applied

## 4.2.2. Flex Resistors

When considering sensors for haptic feedback we also have the case of using flex resistors. These resistors behave in the same manner and the rounded FSRs, but the value of resistance is dependent on the magnitude of the bend of the resistor, rather than the force applied to it. Unlike the other resistor, when the flex resistor is not bent, the resistance will be a flat value specified by the individual part. The flex resistor keeps a low profile, due to its extended length, and because of this the resistor can fit within tight spaces and can handle a lot of torque. Figure 13 shows the purpose and design of the resistor, demonstrating the effect of bending on the component.

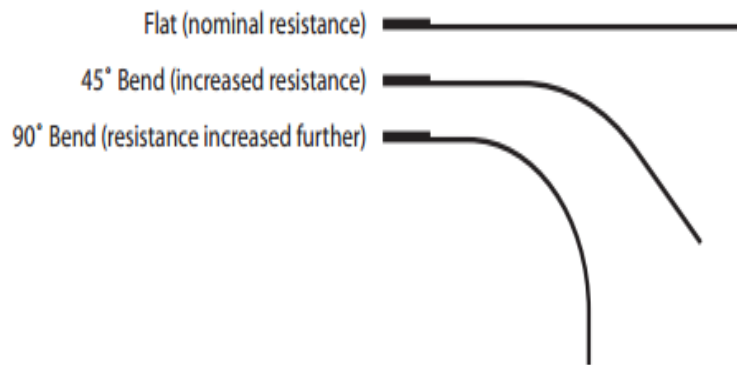

Figure 13: Flex Sensor Functionality®

In the application of using these flex sensors, there are certain tradeoffs. It was previously mentioned that with no bend the flex resistor has a flat resistance value, which is not creating an open circuit. The design for the haptic feedback would have an input voltage going to the flex sensor whenever the arm is powered on. With the flex resistor not acting as an open circuit at standby, we could expect continuous power loss. Rounded flat FSRs are typically a lower cost than most flex resistors. While this price difference is marginal with one sensor, the project could be extended to include multiple sensors for a more accurate response, as well as being able to have the ability to power additional motors with each sensor. In terms of price, the round FSR is the better choice to maintain a low-cost design, as well, which is a goal of this project.

With this design there are also size constraints. The arm design is for a child, where the surface area of their hand is smaller than that of an adult. The flex resistor can vary in length, but the minimum size found is approximately 2.2 inches, or 55 millimeters. The approximate cost of these resistors from Sparkfun, is \$5.95, whereas the rounded force sensitive resistor is \$7.00 from Sparkfun, which features a 0.3 inch diameter. This is the size under consideration due to the size constraint of the current hand.

For the Flex22 resistor, sold by Sparkfun, the flat, or nominal resistance, is 25 kilo-ohms, ranging to 45 to 125 kilo-ohms depending on the nature of the bend. Unfortunately due to the design of the hand, there will always be a slight bend. The height for this resistor is 0.43 millimeters, allowing for the low-profile.

In determination of the signal being created by the bend of the resistor, the schematic for the flex resistor is shown in section 4.2.4. This design is very similar to the schematic of the rounded FSR which is shown within the same section. This design, however, requires the use of an operational amplifier as an impedance buffer.

When trying to drive the input to the MCU, the signal is determined by the bending of the flex resistor. In this scenario, the flex resistors would need to be mounted to the fingers in order to bend as a result of the action of curling the fingers. By mounting the resistors, there would be added mass to the finger. While minimal, if additional sensors are used, this would require additional work on the servo powering the finger movement. This situation is non-ideal for the design, where the customer desires the fastest hand response time at a low-cost.

Utilization of the rounded FSR allows for the placement of the resistor(s) to be anywhere on the hand, where the design expects to have force acting upon it. This realization covers a minimal area for the arm and does not exceed the size constraint, while keeping a low profile and not impacting hand response time. After evaluating the parameters and specifications of each sensor, the round FSR is more practical for this design.

### 4.2.3. Inductance to Digital Converter Sensor

Another approach in haptic sensing is through using an inductance to digital converter sensor. Texas Instruments has multiple sensors of this variety, and one of these sensors called the LDC 1000. The LDC 1000 uses short range inductive sensing technology for precise environmental measurements. The device package is 5.00 mm x 4.00mm, creating a sensing solution within a small-footprint. The circuit uses an inductive coil to provide accurate measurements on proximity and can relay the sensing information to a microcontroller through an SPI interface.

Figure 14 below shows the typical values of resistor  $R_p$  based on the distance from a 14 mm diameter PCB coil, demonstrating the impact that distance from the inductive coil plays in sensing application.

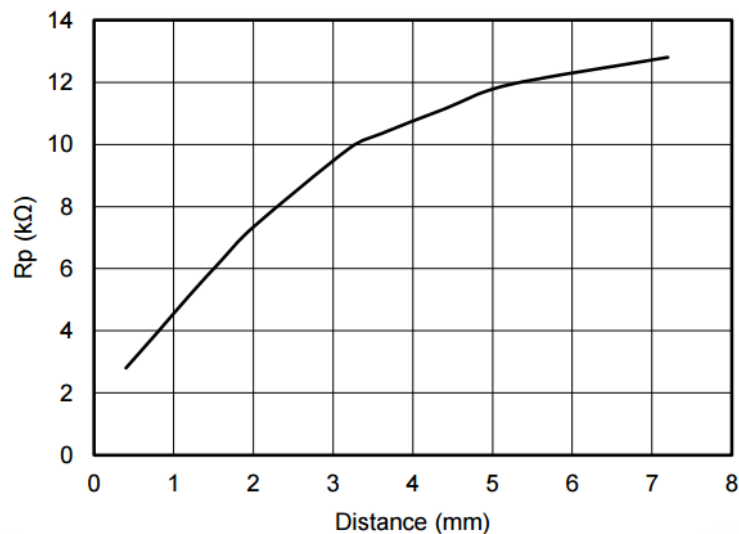

Figure 14: LDC1000 Characteristics\*

After discussing the application with using the LDC1000 as a sensing device with Texas Instruments, there are some issues with the application of this device in the bionic arm. The LDC1000 utilizes its sensing applications with the use of an inductive coil. On the evaluation boards the inductors connected to the device are coated with a sheet of ferrite material to prevent inductive sensing on the other side of the coil. Without this sheet, the inductive sensing would receive interference from the arm itself. Installing the LDC1000 would require the coil to be placed on the palm of the hand with the side touching the hand to have a plate of the non-transmittable material.

While the LDC1000 adds a touchless interface for sensing, the application of this device requires additional materials and a large amount of coding to process the sensing data through the SPI interface to the microcontroller. Additional coding could put a strain on the memory for the microcontroller and cause a delay in the response. Additional materials would add to the cost to the overall design.

## 4.2.4. Sensor Schematics

Figure 15 - 17 show the typical usage schematics found for each type of sensor. Figure 15 for the force sensitive resistor shows a very basic design only featuring the FSR itself, an applied voltage and an additional resistor for sensitivity calibration. Figures 16 and 17, showing the design of the Flex22 sensor and the LDC1000 respectively, feature additional components adding to the complexity of the design. The end result of the electronics package should feature the most efficient design at a low cost, which is not realized by the other sensors.

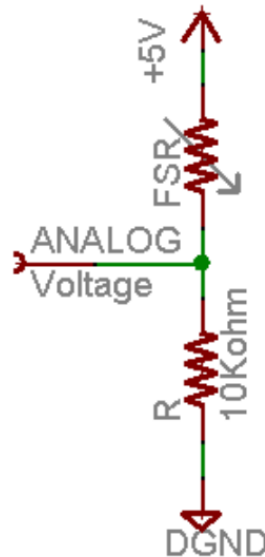

Figure 15: Schematic of FSR~

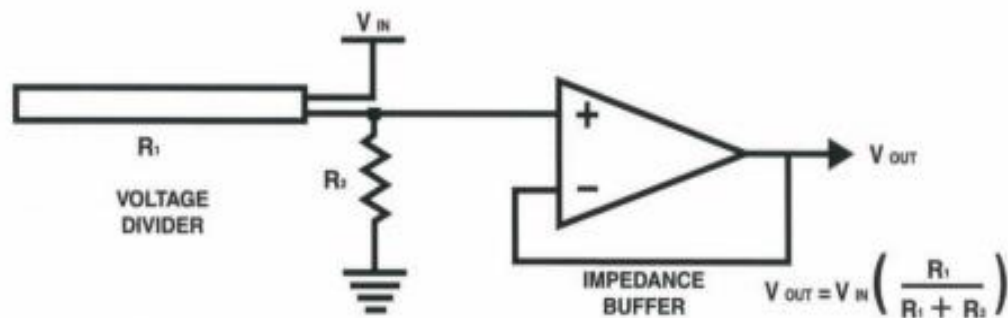

Figure 16: Schematic of Flex22 Sensor®

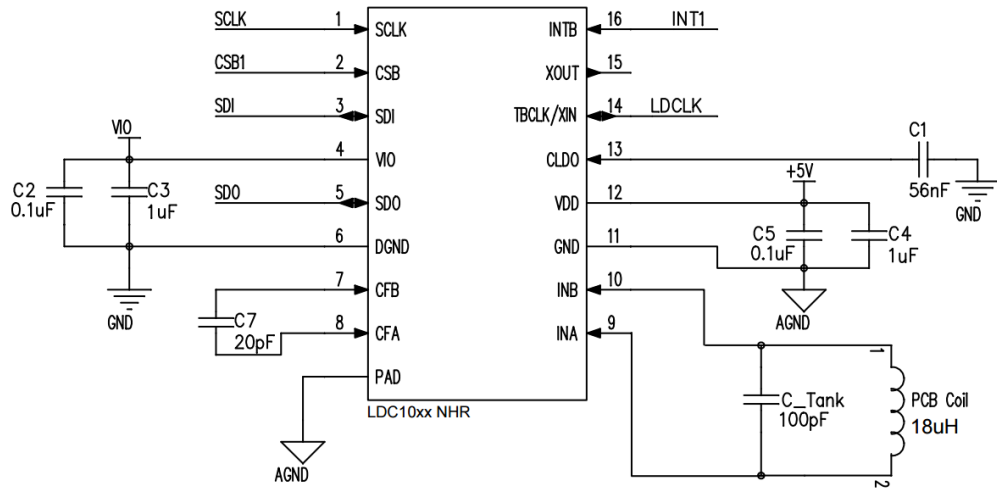

Figure 17: General Usage Schematic for LDC1000\*

### 4.3. Haptic Driver

Earlier designs for haptic systems required the processor to generate the haptic waveforms to be used for the motor and be connected to the driver to output the signal. Drivers are required for haptic systems as the processor, or microcontroller, cannot provide enough current to drive the physical actuator when the output is controlled by a microcontroller rather than a direct voltage. The reasoning for this is that the motors have difficulty in starting the rotation or movement when it has to bypass the forces acting on the device such as gravity when it is not in use. Today, haptic drivers that have integrated drivers and libraries used for haptic effects can be purchased at a relatively low cost.

It is possible through utilization of only the force sensitive resistors and actuators to run a haptic feedback system, as the resistor only has the applied voltage and will run more current to the actuator as the resistance decreases from the pressure applied. The problem with this design, however, is that there are no options for customization of the output signal to the motor.

To solve this customization issue, a haptic driver can be integrated into the design. Through research and by recommendations from Texas Instruments, the group has determined an integrated circuit that can be used as a haptic driver for the design. This integrated circuit is the DRV2605, highlighted, by Texas Instruments. Other haptic drivers such as the DRV2667 are also available for these types of systems, but do not have embedded functionality for operating the actuators typically used in haptic feedback systems. Comparison to other similar products is shown in Table 6 below.

Parameter	DRV2605	DRV2603	DRV2604
Vs (Min) (V)	2.5	2.5	2.5
Special Features	Integrated Haptic Effects Smart Loop	Auto Resonance	Smart Loop RAM Available
Input Signal	PWM, Analog, I2C	PWM, Analog	PWM, Analog, I2C
Vout (Max) (V)	11	10.4	11
Supported Actuator Types	ERM, LRA	ERM, LRA	ERM, LRA
Startup Time (ms)	0.7	1.3	0.7
Approximate Cost (per 1k units)	1.6	0.7	1.32

Table 6: Haptic Driver Comparisons

In the application of haptic feedback, drivers provide more benefits in creating a haptic feedback system. Common issues with actuators include the duration that the motor takes to start and stop its response. Drivers are programmed through techniques called Overdrive and Active Braking. These two techniques are essential in creating an effective system, and are only possible through the use of a driver. The driver also allows for the design to be programmable and have a wide variety of functionality. Use of a microcontroller alone would not be sufficient enough to power the actuators and enable the haptic response the team is looking for in this system. Table 6 shows the varying types of haptic drivers used in common applications. The DRV2605 provides the most functionality of the three comparable devices, while still maintaining a relatively low cost for the design.

### 4.3.1. DRV2605 Specifications

The DRV2605 is an Eccentric Rotating Mass (ERM) and Linear Resonant Actuator (LRA) Driver. The communication for this device is over an I2C bus or PWM input signal. This device allows for high flexibility over control of ERM and LRA actuators. Normal usage with haptic motors and sensors provide a direct interface, for digital or analog functions for power mode.

The DRV2605 has an embedded library of 123 different waveform effects for the output PWM signal. This allows to control the input that the actuator is receiving. The arm can be customized to the extent where if the child is grabbing an object with the arm, the child can receive a haptic motor feedback in the form of a sinusoidal pulse. This allows for the design to be customized for the individual if the standard haptic feedback produces too large or too small of a pulse, or even the frequency in which the pulse is received.

The driver has a range of input voltage for 2.5V - 5.2V. This range provides the flexibility in battery or power consumption. During typical usage, the current draw from the battery ranges from 2.5 to 3.25 mA, at a duty cycle of 90%. Since the haptics will not be powered at all times and must be enabled by the microcontroller in order to be powered, this current draw will be minimal in retrospect.

The driver features a 9-pin configuration, shown in Figure 18, where a single driver will output to a single actuator/motor. For the integration of multiple motors, several of these drivers can be implemented into the design, adding more functionality at a low cost.



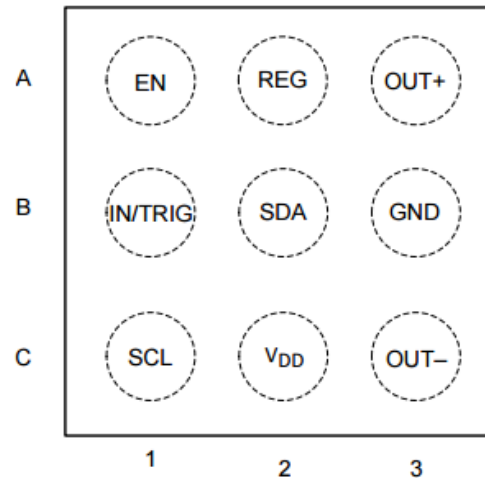

Figure 18: DRV260 Pin Configuration\*

The haptic driver features what is known as a Smart Loop Architecture. This portion of the design allows for the functions of Automatic Overdrive, Braking, and Level Calibration. The Overdrive functionality allows for fast startup time. Automatic Braking functionality allows for quickly ending the response from the actuators by effectively stopping vibrational movement.

Braking is necessary for most variations of actuators as this is known to be a common issue in precision. Features for level calibration are embedded within the software of the DRV2605 to produce near uniform haptic waveforms. Without this driver capability, the output waveforms could undergo amplitude variance after a long duration of repetitions, especially for ERM devices. The LRA devices have an additional routine for auto resonance, which ensures that the frequency at which the waveform is sent out is monitored and makes corrections as it is tracked.

### 4.3.2. Driver Signal Communication

Haptic drivers typically communicate with a host system, or in this case a microcontroller, to provide a haptic response.

A signal can communicate with the DRV2605 directly from the Haptic Sensor without the use of a microcontroller to produce the signal. The Haptic Sensor could easily be connected directly to this interface driver, but for the purposes of configuring the driven signal to meet the needs of the project, the signal will be relayed through the microcontroller and communicate with the Haptic Driver in order to produce a haptic response in the motor.

The DRV2605 uses I<sup>2</sup>C communication with the microcontroller. This integrated circuit will receive a 7-bit slave address generated by the master device. The device will acknowledge that it has received the 7-bit address and then be sent the next byte in the sequence. The data will be sent through the bus serially, where one bit will be transferred at a time.

In this communication line, the microcontroller will process the output voltage received from the haptic sensor, and create the appropriate signal output to the haptic driver. Preprogrammed tolerance levels will be used to ensure that the output signal to the driver is not sent at low pressure tolerances. The purpose of the haptic feedback in the system is to provide a response for the user whenever the hand is closed on an object.

The I<sup>2</sup>C bus on the device uses two signals, the SDA and SCL, which are used for data and clock respectively. These signals are shown on the pins above, B2 and C1. Since the driver will be configured in this manner, the trigger pin on the figure above will be able to be grounded as the trigger will be created externally by the microcontroller through the data and clock paths. For the actual design, this line will be connected to the microcontroller for testing purposes, but will be grounded if unnecessary.

Texas Instruments offers a design configuration tool for the DRV2605, to configure the registers used in this interface. This tool will be used to configure the communication with the microcontroller and the haptic feedback motor.

### 4.3.3. Integrated Waveform Library

As stated previously, the DRV2605 contains a library of 123 waveforms. The library is accessed from the LIBRARY\_SEL field in the register field at the address 0x03. The selection of the waveform is dependent on the two bits allocated to the LIBRARY\_SEL field.

This field contains a total of six libraries, five for ERM Devices and one for LRA devices. These actuators will provide the haptic response from the sensor, and the motor output must be configured correctly to produce the desired result. To drive the actuators with a specific output, the vibration output will simply be selected on the device and the driver will output the correct signal based on the preprogrammed parameters.

The integrated waveform library gives the design the customization to the haptic feedback system. Waveform output can be configured to different waveforms sets within a programmed array based on the input signal from the microcontroller.

The full set of waveform effects is attached within the corresponding datasheet section of this document. For reference purposes, the libraries for the ERM device are shown below, with included Start and Stop times to show the variance across waveforms. As shown by table 7, the ERM features a very short stop time, allowing for the cutoff for the response to be almost instantaneous. This table was created by Texas Instruments to support the troubleshooting and selection of waveforms for ERM Devices.

Library Selection	Actuator Properties	
	Start Time (ms)	Stop Time (ms)
A	40-60	20-40
B	40-60	5-15
C	60-80	10-20
D	100-140	15-25
E	>140	>30

Table 7: ERM Waveform Effects Properties

While ERM actuators have more available haptic effects from the driver, the amount of customization should not prove to be an issue if using an LRA device. While the amount of customization is indeed helpful for providing more of a variety, the list of effects for LRA devices prove to have more than enough customization

available for the bounds of this design. The differences in variety of the two actuators is solely due to the design of each actuator. ERM devices have a wide variety of customization due to the fact that these devices operate in two axis, as opposed to LRA that only operates in one axis. This allows for customization of the amplitude and frequency of the response, but this will be discussed further in section 4.6 below.

### 4.3.4. Haptic Driver Schematic

Figure 19 below, shows the typical usage schematic of the DRV2605 connected to a microcontroller interface or processor. For usage with the DRV2605, the values of the pull up resistors are recommended to be between  $660\Omega$  and  $4.7k\Omega$ , this is to ensure that the voltage on SCL and SDA is not greater than the input voltage  $V_{DD}$ . Typically the standard usage of pull up resistors ranges from  $4.7k\Omega$  to  $10k\Omega$ . The parameter range mentioned previously is due to the fact that the DRV2605 is known to be used with audible to haptic conversion where noise on the signal is expected to occur frequently. For the purposes of this project the resistance will be set to  $4.7k\Omega$ , and will be adjusted if necessary. The capacitors shown in the schematic,  $C_{REG}$  and  $C_{VDD}$  are required to be  $1\mu F$  and  $0.1\mu F$  respectively. This reference design will be used in the application for the overall haptic feedback schematic.

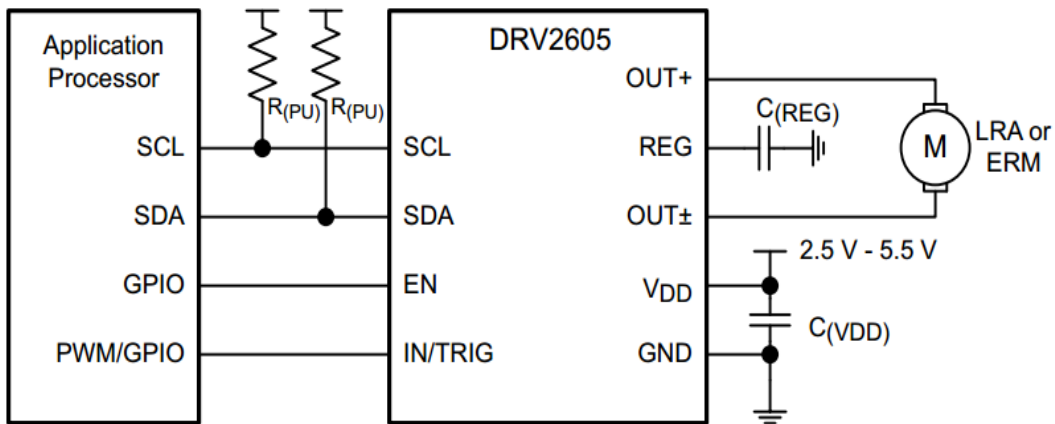

Figure 19: Typical Usage Schematic for DRV2605\*

## 4.4. Haptic Feedback Mechanism

Haptic Feedback Systems utilize a vibrating component, such as a motor or actuator, powered by the output of a designed circuit. In common practice, the microcontroller is programmed to provide a signal to cause the motor or actuator to vibrate, when certain conditions are met for the system. This signal can be modified and controlled by a haptic driver, such as the DRV2605, to control the motor or actuator.

The intended use for this product is to sense when the hand is closed on an object. The EMG input to the arm, acts as a digital signal, indicating to open or close the hand. Since the signal received from the EMG sensor is not analog we can determine that the amount of resistance will stay within a certain tolerance range. Through use of the haptic driver and haptic sensors from the previous sections, the design can generate a PWM signal sent from the microcontroller to the driver in order to power a haptic feedback interface.

This signal will be relayed from the haptic sensor, processed at the microcontroller, then be interpreted and modified by the haptic driver before being sent to the actuator. When the signal is sent to the haptic motor/actuator, it will vibrate causing a haptic response. Using the integrated waveform library, the design is able to customize the signal being sent to the actuator.

Common examples of haptic feedback actuators include the Linear Resonant Actuator and the Eccentric Rotating Mass Actuator. These devices enact the vibration response from the motors from the PWM signal driven to the actuator by the haptic driver. Based on the design of these two different actuators, the customization and nature of the response can differ.

## 4.4.1. Linear Resonant Actuator

Linear Resonant actuators are built with a magnetic mass and spring. The electric current flowing through the device allows for the mass to move. For this movement, the signal must be an AC Signal in order to pulse the mass in a forward and backwards direction. This importance on signal is why the haptic driver has different sets of libraries for the LRA and ERM actuators. In order to demonstrate the functionality of the LRA the build of materials for the device are shown in Figure 20 below.

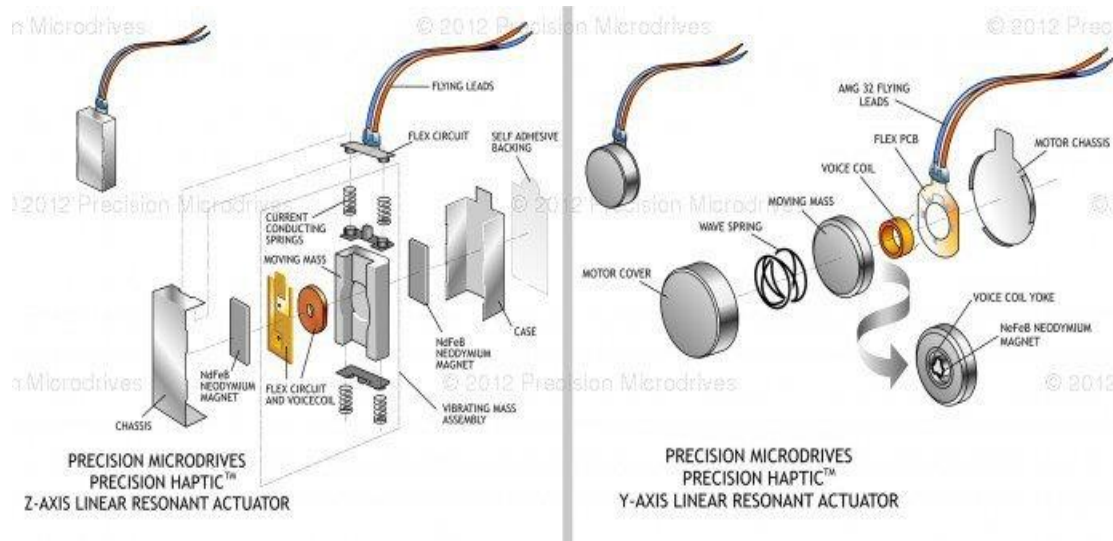

Figure 20: Inside of the LRA+

There are several varying advantages and disadvantages to this design. Because of the actuator's design, the movement is along one axis. For this single axis design the actuator can vibrate at a fixed frequency, and not be affected by the amplitude of the vibrational response. Compared to the ERM devices, the LRA does not feature any internal braking devices and is rather simplistic. Due to this simplicity, this type of actuator holds a longer life and effectively has a faster response time in comparison to ERM devices.

The above figure shows the two varying shapes for this type of actuator. For the application of the T.U.B.A the rounded shape would be the more ideal choice as it holds a lower profile and could be mounted on various locations. The larger surface area holds a more ideal ability for mounting with an adhesive.

LRA devices run typically small compared to other actuators. With the small size the amplitude of the vibration is relatively small. The minimal amplitude is not a terrible disadvantage for use in this design as the intended use is for children and the response is not intended to be strong. The design specification must be taken note of for the application of the actuator depending on its location.

With the fast response time of the LRA there is an almost instant haptic response. The tradeoff with this design is the fact that it does not have any mechanical braking components and typically the motor takes a duration of time to stop the response, in comparison to other actuators, when the user is no longer touching an object. This problem occurs fairly often when the actuator is used without a haptic driver. With the application of the DRV2605, the driver has the integrated functions of active braking which limits the possible delay. The active braking allows for the response to come to a halt by feeding a response in the opposite direction for the AC signal being sent to the motor. This functionality is a simulated braking system in the programming of the haptic driver.

## 4.4.2. Eccentric Rotating Mass

For haptic feedback applications the other actuator variant of choice is the Eccentric Rotating Mass device. The device uses an unbalanced weight attached to the motor shaft, which rotates when current is supplied to the motor. The force created by the shifting weight about an axis causes the vibration sensation used in haptic systems. This device's application is very common in pagers or cellphones and has a very natural responsive feel. The ERM response time is not as instant as the LRA device, but the delay is known to be minimal. The precision in the haptic response is not critical for this design, and a tenth of a second delay would not have an impact on the goals of this project.

These devices can be run directly through a voltage source and do not require a haptic driver. With the addition of the driver, however, the designers are able to change the amplitude of the response by varying the rotations speed. This change in speed is what varies the frequency and amplitude of the vibration response.

There are two general types of ERM devices, such as the cylindrical and round variants shown in Figure 21 below. The size and shape of the device is important to note based on the effectiveness of the feedback response. The design to the right of the figure shows the shaft-less design, similar to the LRA in the previous section. The rounded design is the ideal choice due to the limited area within the housing or for other areas of application on the T.U.B.A.

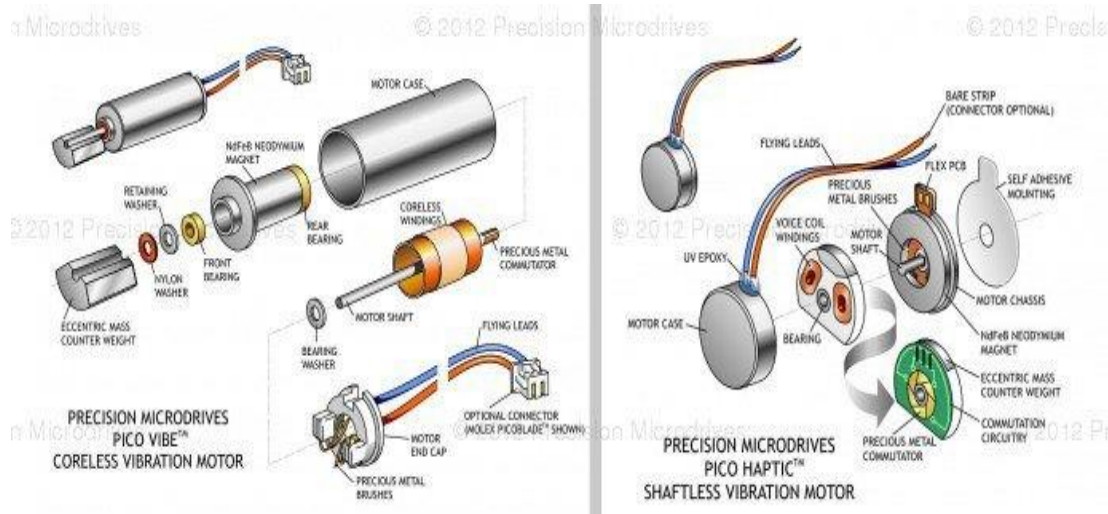

Figure 21: Inside of the Eccentric Rotation Mass Actuator\*

The ERM actuator is composed of a DC motor, meaning that the PWM signal powering the motor does not have to be an AC signal, which is the case for the LRA. As opposed to the LRA, the ERM has a large set of integrated waveform presets for the haptic driver, increasing the scope of customization for the design.

For the selection of an ERM actuator the pick of choice would be the shaft-less vibration motor, for its low profile. The larger cylindrical shapes are typically more massive, in order to produce a stronger response. As the scope of this design is to produce a response that acts as an alert, the amplitude of the response does not have to be very large.

The differences between the two actuators is relatively low, but for the purposes of this project, the LRA device is the pick of choice to realize the feedback mechanism. LRA devices are not as sensitive and do not require additional calibration functionality. The driver supports a wide variety of functional braking specifically for the LRA, and is more practically used in most similar designs. The item can be purchased at a low cost at Precision Microdrives for \$10.14 for the 4mm size. The LRA features a low response delay, making it the faster actuator. During the prototyping phase of the project both actuators will be tested to evaluate their performance, but the design team has chosen the LRA as the actuator at the time being.



### 4.4.3. Motor Application

For the arm, the goal is to make the haptic feedback recognizable by the user to make them acknowledge that they are touching an object. Due to the EMG sensor, the child will already have several components attached to the arm while in use. The addition of more components could make the user feel uncomfortable.

With ERM and LRA devices it is generally recommended that the motor is placed in a fixed location. Because of this recommendation there are a limited number of locations on the arm in which the actuator should be placed. When constructing a haptic feedback system it is important to ensure that the free space around the actuator is limited.

One of the options is to place the motor within the housing of the arm and mounting it to the inner surface. Placing the motor inside of the arm allows for it to be held in a fixed location. While this situation provides a fixed surface, the problem for this case would be the noise that the arm makes. For the nature of the response, the skin should be in close contact near the actuator. To create an almost universal device it is important for the design that the actuator is fixed to a location that all user will be able to experience. Mounting of the actuator on the housing of the arm would benefit children who aren't missing the entire forearm, but would not yield the same response for those who are.

Placement against a hard surface that is moved frequently can cause the device to become loose from the surface. Because these devices use vibrations to create a response, noise is known to be a large issue. As repeated vibrations occur, the motor will move around its enclosure creating noise and limiting the amplitude of the response. Excessive loud noises could cause the user to interface with the arm less frequently and make it uncomfortable to utilize.

When the bionic arm is attached to the user, a strap on the housing is used to fix the back of the arm to a point on the child's arm. Attachment of the LRA at this location provides a fixed point. In order to limit the contact of the motor and the individual the actuator can be placed within the strap. Being close to the attachment point will allow the haptics to give a natural feel that will yield an instant feedback to the user. Encasing the motor within the strap material would provide an effective insulator for noise as well.

When using vibration motors in a haptic system, it is essential to point the direction of the vibration towards the intended purpose of the response. Different motors direct their vibrations in different directions or axes. Using an LRA motor the direction of the vibration will occur in only one axis. Based on the previous figure for the rounded actuator variant, the direction of the vibration occurs on one axis on the circular surface of the device. As this surface provides the direction of the vibration, it is important to place that surface parallel to the surface of the child's arm. This method will ensure that the motor is able to produce its full response if need be, and will be configured through the driver otherwise.

#### 4.4.4. Feedback Constraints

When the intended customer is using T.U.B.A there are certain constraints that the design must keep in mind, so that the intended customer does not feel that the response feels uncomfortable.

Actuators will vibrate according the current that is driving them. The more current being supplied, the larger amplitude of the vibrational response. As mentioned in previous sections, too much of response could hurt or cause potential harm the user. The haptic driver generally takes care of this issue as the feedback can be modified and customized for the individuals need. Generally with LRA devices the response of the actuator isn't very strong in amplitude in comparison to the input voltage applied to it.

During the prototyping phase of the project, the LRA as well as the ERM devices, will be tested for general purposes and configured for the default settings and libraries. During the course of the design, the settings of the DRV2605 will be customized before implementation on the final design.

With the haptic driver there are also the possibilities of receiving noise on the data and clock paths, which could cause additional edge triggers to be read in accidentally by the driver causing excessive responses. This issue must be monitored and tested. If this issue occurs, the value of the resistance on the pull up resistors must be decreased.

Previously mentioned, Texas Instruments offers a design configuration tool that demonstrates the layout of registers values to meet a certain design. This same tool also offers the voltage equations, to determine the maximum as well as maximum voltages going to the LRA device, based on the parameters of the input and specifications for the LRA. The parameters for the LRA device are shown in Table 8.

Parameter	Specification
Body Diameter	10 mm
Resonant Frequency	175 Hz
Operating Current	69 mA
Rated Voltage	2 V (RMS)

Table 8: LRA Specifications

### 4.4.5. Mechanism Schematic

Figures 22 and 23 below illustrate the schematics that will be used for the haptic driver and sensor.

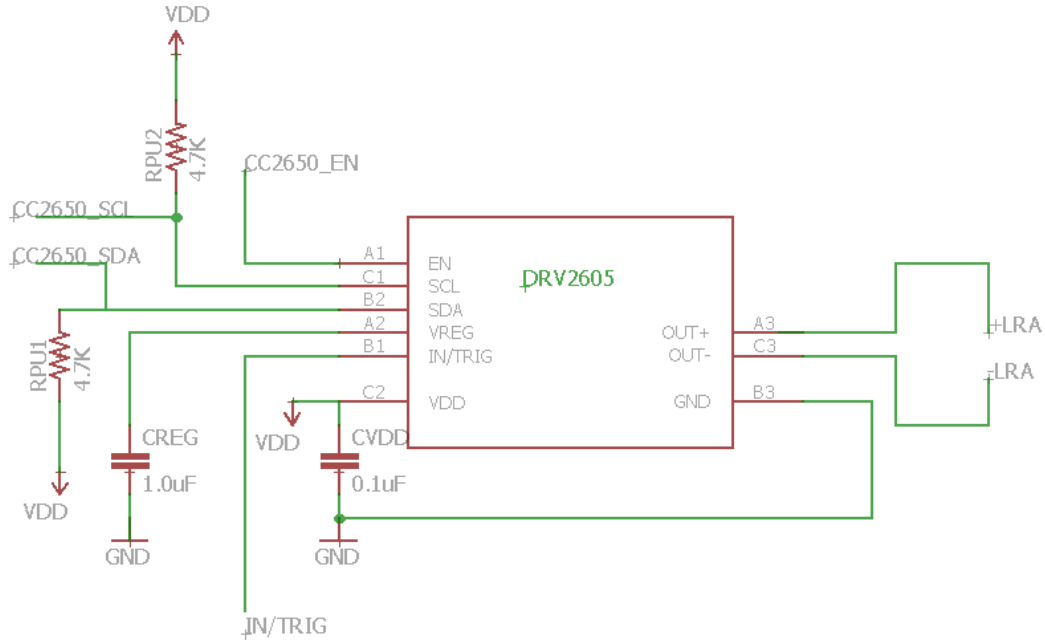

Figure 22: DRV2605 Eagle Schematic

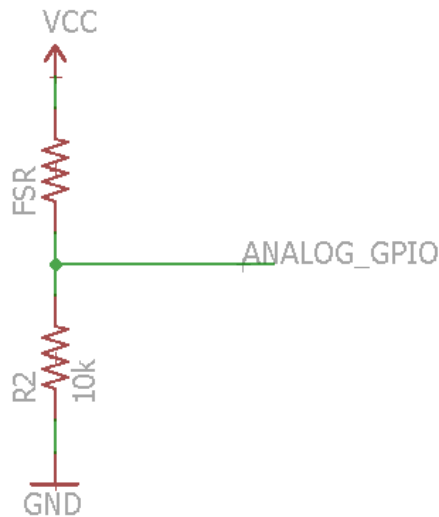

Figure 23: FSR Schematic

## 4.5. Over-the-Air Programming Comparisons

A much desired feature wanted for the new evaluation board is the ability for the device to be programmed via an “over-the-air” (OTA) programming standard. While the obvious suggestion made to the authors was today’s golden standard, Bluetooth, this section serves to investigate several of the existing solutions available today to ensure that that this technology is the optimal choice for this device.

The team has outlined two stages of functionality to be achieved for the arm’s OTA protocol. The most important of these two, which is the main desire of the client, is the ability to program the system wirelessly, ideally from a laptop. Alongside wireless charging for the system’s battery, this innovation is the defining requirement needed to allow Limbitless to permanently seal the electronics housing, thus preventing unwanted meddling by the operator, or, more commonly, the operator’s parents. Sealing the housing will also provide additional resistance to environmental factors, such as dirt and water. Therefore, the predominant need in the electronics package is a wireless receiver module mated to the microcontroller capable of interpreting instructions sent OTA, reprogramming the arm when updates or debugging is required. With this innovation, future engineers will no longer be able to reach the electronics inside without the destruction of the housing.

The second stage of development, which may or may not be taken on by this team, is to also make the arm capable of transmitting varying forms of the arm’s own data. With this ability, the possibilities of what could be done are endless. Possible examples include the use of EMG sensor data to be integrated as an input into a simple game, such as Flappy Bird, encouraging the operator to work the relevant muscle groups in the arm through a form of entertainment. Further, important data such as battery life, current software version, and other important metrics could be fed through the transmitter to a form of Android or iPhone application to be displayed through the operator’s phone, keeping them informed of how much battery life they have left. The microcontroller could also be tuned to collect precious data that could be collected during software updates. With this data being taken, Limbitless could more accurately design their product in alignment with the needs of their customers.

The hardware implementation of this seems simple, as all that is needed beyond the pinout already required for the above step is a single additional UART line to a transmitter pin on the MCU. The larger task for this to be a viable option is the need for software complete with a user friendly GUI, which, with no computer engineering representation on the team, may be left to future evolutions of the Limbitless arm.

### 4.5.1. Wi-Fi

802.11 networking, more commonly referred to as Wi-Fi, is more prevalent in today's society than any other wireless data service present today. Wi-Fi passes data via radio signals through an adapter attached to the microcontroller. The adapter translates the data into a wireless signal that is broadcast via those radio waves through an antenna. That signal is then picked up by a router which decodes the signal, and sends it to the internet via a hardwired Ethernet connection.

Based on the general algorithm outlined above, Wi-Fi has some interesting conceptual ideas that may be integrated into the product, at certain costs to the project. Provided that parts could be sourced to fit inside the electronics housing, the potential exists to push software updates wirelessly from the Limbitless main office, without need of physical presence of the arm, or even the dispatching of a technician. With the permission of the operator's parents, a TCP/IP connection could be established at the home Wi-Fi network of each client's arm, allowing Limbitless to achieve access to each arm through the internet. This would allow Limbitless to easily push new software as it is published, as well as provide potential for data collection from the arms through future data mining software. The method would be for the program data to be pushed through the internet to the router of each respective client household, where the program would be automatically updated. Some form of notice would have to be given, however, to ensure that the arm is not in use and is ready to receive these updates, including being powered on.

The problem with this idea lies in two major problems: privacy and power requirements. For Limbitless to be able to achieve the possibilities above, the Wi-Fi module in the arm would need to be switched on at all times, to ensure data collection, or program delivery. This would ultimately lead to potential privacy issues with the user, as the parents of the operator may perceive issues with the notion that their child has an arm that is in essence being tracked through the software, even though locational data is not being collected. In addition, with the module constantly on, it will be drawing power to search for a viable network to connect to, reducing the ever important metric of battery life that this team has been asked to improve.

Overall, Wi-Fi has several alluring facets that in future designs may prove to be lucrative to Limbitless' vision for their arms, but for this iteration, lack of cryptological skills on the team, as well as a desire to set the power benchmark as high as possible discount the ability to implement these solutions. Due to these reasons, it is believed that a better communication protocol than Wi-Fi may be sourced for the device.

## 4.5.2. Bluetooth

Also relying on 802.11, Bluetooth is today's most popular standard for wireless data transfer. Much like Wi-Fi, this communication method sends data over radio waves at a frequency of 2.4 GHz over an established paired network known as a piconet. A recently released protocol of Bluetooth, Bluetooth Low Energy (BLE), or Bluetooth Smart 4.0+, offers rates as fast as 1 Mbit/s, which is more than sufficient for the purposes needing to be implemented here. This protocol is sent at 2.4 GHz, just like traditional Bluetooth, but operates on a separate set of channels. The data is sent via a Gaussian frequency shift modulation, a method that smooths the data transitions to limit spectral width of the signal. However, it may be necessary to register the product upon its completion to be allowed to use the technology. In addition, a large forum of information exists in the Bluetooth Special Interest Group (SIG), which would allow future developers to have a sounding board for working inside the environment.

The different devices available in today's market are divided into different classes, as can be seen in Table 9 below:

Class	Max Power	Range
1	100 mW	100 meters
2	2.5 mW	10 meters
3	1 mW	1 meter

Table 9: Classes of Bluetooth

In terms of these operating radii, an analogy may be considered of two HAM radio users trying to communicate with each other. Although the operating radius of the class 2 device is large enough to communicate with the class 3 user, the class 3 user cannot communicate back to the class 2 user. Based on these options, it would seem that the most sensible option for this project is a class 2 device, which would allow a technician to locate the arm from his terminal easily inside a living room. This device ideally would operate using Smart Bluetooth 4.0+, for the additional savings to the power draw. Class 3 may also be possible to implement, but the arm would need to be located in closer proximity to the terminal applying the software updates, as the effective range between two devices is the smaller range of the two. This would more than likely require the removal of the arm from the operator during update reprogramming, which may or may not be a desired functionality during reprogramming. Class 3 devices are also extremely uncommon in today's production of chips and integrated components, and therefore, it seems like a class 2 device is the correct choice if Bluetooth is the communication protocol chosen for the arm.

### 4.5.3. UWB

Ultra-wideband communication (UWB), also known as digital pulse wireless, is a lesser known data transfer protocol that is normally reserved for radar applications, but is becoming more normalized in today's data transmission algorithms. UWB utilizes a large bandwidth of approximately 500 MHz to 1.3 GHz. By the Shannon capacity formula,

$$C = B * \log_2(1 + SNR)$$

It can be observed that the two proportional relationships that exist to increase the capacity of a channel are to either increase the bandwidth of the channel, or increase the signal to noise ratio present in the channel for the data that is passed, usually resulting in a larger power draw from the system to ensure quality transmission with respect to the noise floor. With this larger channel, UWB has the ability to send a tremendous amount of data. A recent company, Time Domain, was reported to be able to implement the technology on an IBM chip for the transmission of 1.25MB/s, with the ability to increase this 1GB/s.

Traditionally, a communication protocol packages its message by altering either the amplitude, phase, or frequency of a carrier which modulates the message before it is broadcast. Typically, this carrier is a form of sinusoidal wave, whose frequency dictates the point of the bandwidth that the message occupies. However, in the UWB process, information is transmitted through various energy pulses across the wide bandwidth in question, effectively using time as the variable of modulation. The pulses generated are extremely short, ensuring that signal reflections do not overlap the information, effectively defeating ISI. Multipath fading is also not an issue, as this is normally an issue reserved for narrowband signals; the major interference issues present in ultra-wideband communications are multipath propagation and inter-pulse interference, which are both able to be overcome via effective code .

For the purposes of implementation, UWB does not seem a likely candidate for this project. While the technology has been deregulated by the FCC for unregulated use, other challenges would need to be met to implement this technology. The primary challenge is the lack of readily available components to implement this technology. A system similar to that of AM or FM modulation would need to be designed from discrete components to accomplish this communication protocol. While the discrete components on the side of the device seem easy enough to implement, it is the integration with an already assembled computer that seems to be the challenge, especially when other communication protocols, such as Bluetooth or Wi-Fi already exist in device at the plug and play level. Therefore, UWB is not recommended for implementation.

#### 4.5.4. ZigBee

Based on the IEEE 802.15 standard, ZigBee is a mesh network communication protocol rapidly growing in popularity for the easy generation of personal area networks. Designed to be simpler to implement and less expensive than its competition, ZigBee seems a competitive choice for implementation versus Bluetooth or Wi-Fi.

At first glance it seems that ZigBee and Bluetooth are two completely separate communication methods. However, in truth, both Bluetooth and ZigBee are based on the same IEEE standard, with ZigBee being a derivative of Bluetooth made to address the power issues at the heart of the Internet of Things. Bluetooth is a very effective method of wireless communication, but is also a relatively large drain on resources when examining applications involving non-constant power supplies, such as 115VAC from the typical NEMA 5-15 receptacle. Therefore, ZigBee is superior to Bluetooth from a numerical power standpoint, requiring much less energy over a large period of time to keep the network intact. This savings does not come without a price, however. A reduction in power results in a reduction of the power signal being broadcast. This power reduction, as we've seen before in Shannon's capacity equation, results in a reduction of the signal to noise ratio, effectively limiting ZigBee's data transfer rate to a mere 250 Kbits/s versus Bluetooth's much more robust 1Mbit/s. ZigBee is also dependent on line of sight as a result of this power reduction. ZigBee's main implementation area is also for a system that operates off a non-rechargeable battery, where lifespan is of crucial importance. This is not the case in our design, where the power system will be charged frequently, on at least a daily basis.

Joanie Wexler of network world summed the differences between the two nicely: "Bluetooth is more oriented toward user mobility and eliminating short-distance cabling; ZigBee aims more for grand-scale automation and remote control". ZigBee seems to be the far dominant communication protocol if the idea were to build a network of several networked devices. It is superior in prolonged power consumption, number of devices that may be connected, and ease of implementation. It also takes a fraction of the time to connect to the network, at 30 milliseconds, versus Bluetooth's approximately 3 seconds. However, none of these objectives, apart from the power savings, are of any importance for this realization, and the resulting loss of line of sight may cause issues with what Limbitless envisions their software update visits to be in the future. In addition, most laptop and personal computers these days come preconfigured to implement or communicate via a Bluetooth network. This is not the case with ZigBee, and a separate transponder would need to be designed to communicate with the electronics found inside the arm. This seems non-ideal from a cost standpoint, as well as creating an additional PCB/USB module that would need to be prototyped and tested. Therefore, Bluetooth is recommended over ZigBee as the communication protocol for this project.



### 4.5.5. Near Field Communication

Near field communication (NFC) is a low-power, contactless form of communication between devices, normally reserved for smartphones and tablets. A major feature of the near field communication is the ability for quick connections between devices when they come into range of each other. The technology allows an active device, identified in the standard as a “reader,” or “interrogator,” to create a radio frequency via magnetic induction that communicates with another NFC compatible device holding information that the reader wants. NFC is also two way, allowing the reader to also transmit data if that ability were needed in the future.

A major discrediting characteristic of NFC for this project’s purposes is the relative range it requires. The effective range of NFC is usually inside the range of four inches, which is far below for the desired range. The main focus of this technology is on quick small data transfers, such as “swipe to pay” credit card transactions, and data transfers from phone to phone, such as image transfers, where the two devices maintain a data connection for only a few seconds before severing the link between the two. In addition, the data transfer rate of NFC is also subpar to other options, passing data at a mere .424 Megabits per second. This is only 25% of the data rate of Bluetooth. This may, however, be enough to work. The standard file size of the common source file is usually far less than that of the common image file. The difficulty will lie in the question of whether the data can be written into a form of non-volatile memory fast enough to merit the use of the protocol.

The NFC process, however, is not without its own advantages. It is by far the protocol requiring the least amount of power, requiring only an average of 15 mA to operate. While the working range is much less than Bluetooth, this results in less interference between devices, which is possible with Bluetooth if multiple devices in the area are attempting to communicate simultaneously. NFC also does not require a pairing procedure to be performed prior to use, as is the case with Bluetooth.

While not ideal as the desired communication protocol for this project, an option that does exist is for NFC to act as the gateway to another protocol. NFC can be configured in such a way that it quickly establishes the connection between two devices by bringing them into close proximity, and then swapping from one protocol into a second, such as Bluetooth, for the faster data rate and wider working area network. This has been implemented in other designs before, and can be done, but would require yet another chip to implement, as the NFC requires a chip just as any other protocol. This would potentially solve the need for the dual power button, as the system could be configured to power up the OTA chip chosen upon the connection made via NFC. The tradeoff to this is obviously that the NFC chip would be on constantly, resulting in yet another component constantly drawing power. Taking these options into account, the recommendation is to abandon the NFC protocol in search of a communication solution more in line with the desired solution.

## 4.6. Over-the-Air Programming Implementation

A cause of major concern is the power requirements for a Bluetooth module to be constantly on. The authors decided the easiest solution to this problem, as the client only wishes at this moment to utilize the Bluetooth for reprogramming purposes, was to only provide power to the Bluetooth module when reprogramming is necessary. An immediately obvious solution to this problem is a single pole single throw switch (SPST) that could easily be toggled to turn the module on and off. This creates its own set of issues, however, such as accidental toggling of the switch, protrusion of the switch from the arm, and again, interfering in the electronic components by parents.

After several metamorphoses of the needed solution, the authors decided on a novel approach to problem, which is to hide the button in plain sight. A current feature that was already agreed for integration was a small button embedded on the arm that will run an interrupt program when it is pressed, which is a calibration routine for the EMG sensor. Just as the power button of today's modern computer has a secondary function when it is held in for 5-10 seconds in cutting power to the computer, the authors plan to integrate the same functionality: holding the calibration button in for 5-10 seconds will result in a secondary function, which is the toggling on or off of the Bluetooth module. A visual signal such as an LED may be placed somewhere on the electronics housing to indicate to the technician that the prolonged press has succeeded in supplying power. Additionally, a timer circuit will also need to be integrated that will turn the module back off after a determined period of inactivity.

### 4.6.1. CC2560 Bluetooth

The CC2560 is a wireless Bluetooth module built by Texas Instruments that allows multiple formats of Bluetooth to be integrated, including Bluetooth basic rate, enhanced data rate, as well as low energy protocols established by the Bluetooth special interest group, the operating body of the Bluetooth standard. Audio codecs and various other forms of data may also be passed via this device, but are not required for this project.

The chip is a slave device, requiring a Host Controller Interface connection via an H4 UART connection to a master device, such as an MSP430, and acts as an intermediary between the Bluetooth signals being received and sent out. Other interfacing requirements for the module are a clock, which may be independent, or shared from the master device, input power supplies between 1.8 V and 3.3 V, and a propagating antenna if transmissions need to be made.

Implementation of a radio propagation tool for this device at this point would not be necessary. The standard propagating antenna, however, is simply a plug and play device that would simplify future design integration for data transmission, with both chip antennas and copper trace antennas able to be implemented with the

CC2560. The receiver of the antenna may still be used with the transmission pins disabled until a later date when data transmission becomes a wanted goal by the leadership at Limbitless. If Limbitless wishes to market the device, the communications may have to be tested by the FCC as well, which requires the installation of a Band Pass filter to isolate other frequencies, and block noise emissions in the area. Texas Instruments recommends the LFB212G45SG8A127 filter, which may be easily implemented between the proper pins to regulate data flow. Seen in Figures 24 and 25 below, the reference design of the CC2560 shows how to properly make these connections if this device is to be attached to an MCU via pins A26, 29, 32, and 33:

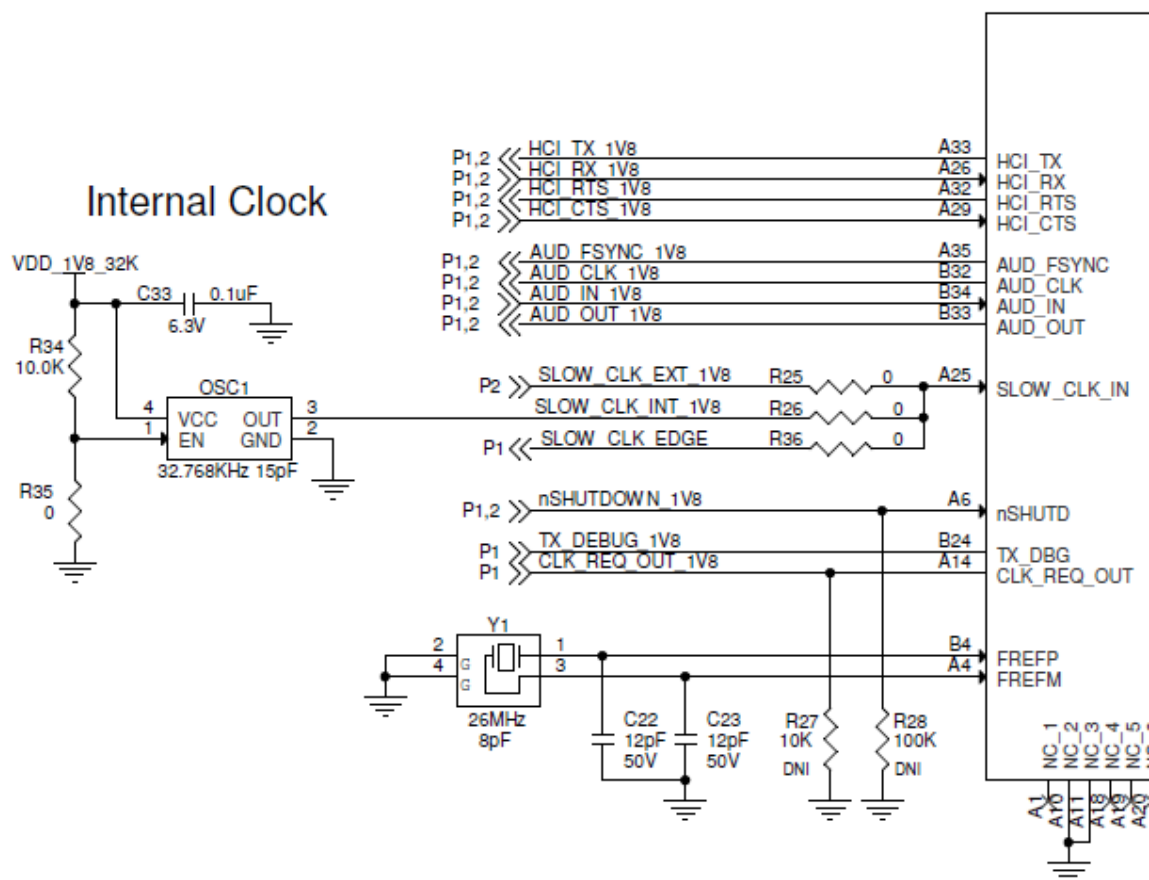

Figure 24: TI's CC2560 Reference Design\*

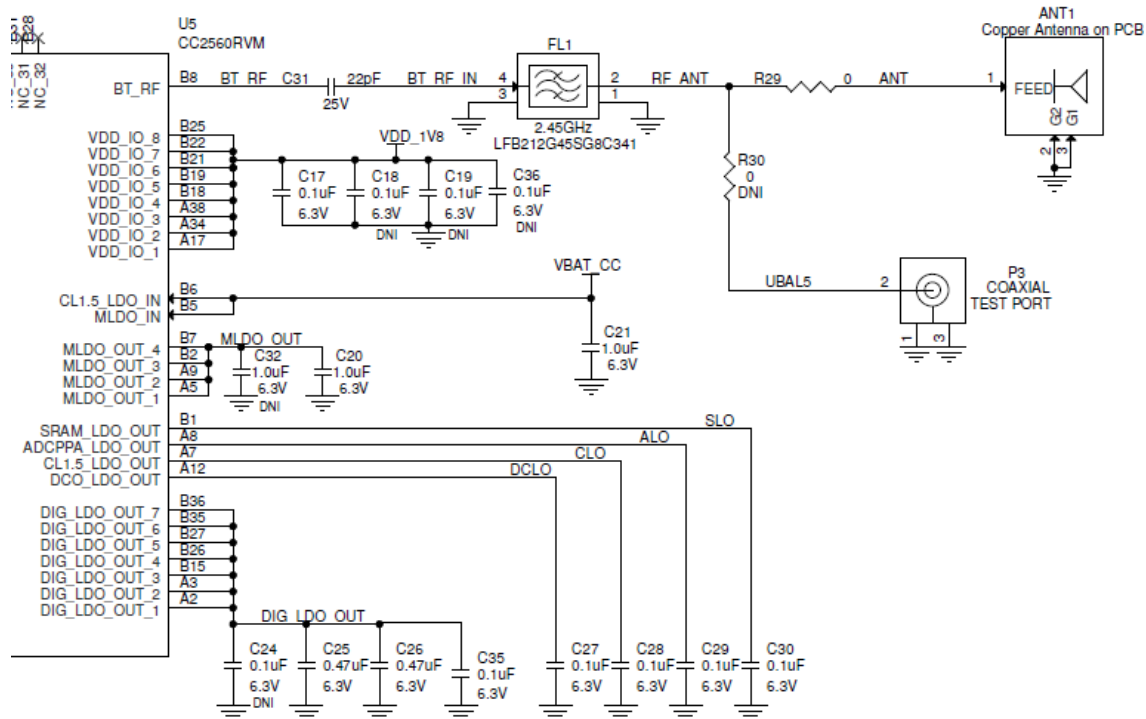

Figure 25: TI's CC2560 Reference Design Continued\*

Power will be more difficult to implement for this chip, as it requires two separate power supplies. A 1.8 V supply is needed at the  $V_{DD} - I/O$  pin, and a 3.3 V input at the  $V_{DD} - IN$  pin, which it may share with the power input for the master microcontroller. This would require an additional regulator, for 1.8 V, for which Texas Instruments recommends the TPS78318 LDO. Another issue that may arise is proper range for the inputs between the MCU and the module is voltage differentials. The input and output levels must be correct between the two devices, with 1.8 V needed on the pins of one device, and 3.3 V needed at the pins of the other. Drawn in figure 26, the easy solution for this the SN74AVC4T774RSV, a bidirectional voltage level shifter, a single chip solution that simply shifts the level of an input up or down across the channel, based on its design, such that a digital high on the 1.8 V side corresponds to a digital high on the 3.3 V side:

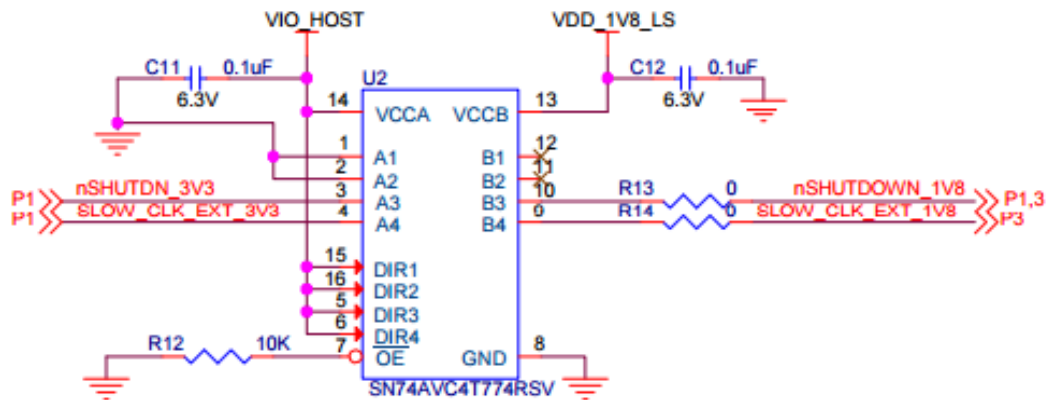

Figure 26: Logic Level Shifter Schematic

Finally, the CC2560 does come with a shutdown pin, which is a desired trait for this part of the solution. With this, the aforementioned power button may be easily implemented to control the power status of the radio network.

Ultimately, this module is a good solution for the alternate proposal outlined in this paper: a dual chip-solution between a standalone microcontroller, and a separate independent wireless module whose power state may be individually controlled to ensure that the device is only in use when necessary. However, it is now apparent that a more robust, streamlined solution may exist in a single chip solution, with a radio subsystem integrated in the chip. Therefore, this solution will still be investigated as a backup option should the primary solution prove to be infeasible, too expensive, or not ideal for the purposes of this project.

## 4.6.2. RN-42

The RN-42 is a class 2 Bluetooth module with a form factor about the size of standard postage stamp, measuring 13.4mm x 25.8mm x 2mm. While reliable, it has been a while since the RF-42 has seen update, and only supports up to Bluetooth 2.1, unlike several of the other solutions with the ability to represent today's standard, which is Bluetooth 4.0. The RN-42 is not without merit, however, remaining one of the most popular chips on the market due to its ease of integration, and relative low cost per chip, with the cheapest version being found on Mouser for \$18.33.

Just like the CC2560, the RN-42 is a slave device that connects to a master MCU through a UART connection. Unlike the CC2560, the RN-42 may also utilize USB as its HCI connection. The device draws relatively low power, requiring only 3 mA to maintain a connection between itself and another device, and 30 mA during data transmissions. However, for the purposes of this project, only the 3 mA would be of interest, as this design does not intend to transmit data from the product.

The data transfer rate of the RN-42 is more than sufficient for the project's needs, with data being transmitted at a sustained 1.5 Mbps, with burst speeds of up to 3.0 Mbps possible. It also holds an advantage over the CC2560 in that the chip has an integrated antenna, which is already certified by the FCC. Therefore, no additional testing is needed should the product ever be officially brought to market. However, the board space required by this antenna, measuring 7.00mm x 13.4mm, must be free of all ground planes, traces, and exposed vias to prevent radio interference.

Ultimately, the CC2560 is found to be a far superior device, with the RN-42 fading into obsolescence. While there is ease of integration with the RN-42 due to a pre-integrated antenna, the cost differential and footprint make this an unrealistic choice. The CC2560 and MSP may be implemented at a fraction of the price, with an approximately equal footprint on the circuit board. In addition, the dual chip solution may be implemented to utilize today's Bluetooth standard, rather than the outdated 2.1 standard utilized by the RN-42. For these reasons, the RN-42 was discredited as a solution for this project.

### 4.6.3. CC2650 Bluetooth

After thorough discussion with a representative of Texas Instruments, the group was pointed to the CC2650 for consideration in the project as well. The CC2650 is a dual mode Bluetooth controller module made by Texas Instruments that, like its CC2560 companion, can implement various forms of Bluetooth 4.0, including basic rate, enhanced data rate, and low energy standards. The difference between the two devices is a major one, however: the CC2650 comes pre integrated with its own ARM M3 Cortex processor. Originally discredited as an MCU solution, the benefit of a reduction to a single chip solution cannot be overlooked, especially when the chip was discredited for being *too* powerful for the application. Therefore, an optimal solution exists in using this module and this module alone to solve the need of the MCU portion of the project, disregarding any other need for a second microcontroller. This is optimal from multiple standpoints including power, ideally, this means that this chip has the ability to communicate via Bluetooth and process the data internally, effectively eliminating the need for a middleman to pass the data via UART.

The C2650 sports low power consumption as well, drawing only  $61 \mu A/MHz$  during active mode calculations, and  $1 \mu A/MHz$  while in standby mode. It is also capable of a 48 MHz Clock speed with an external crystal. It comes preloaded with 20 KB of low leakage SRAM, and 8KB of SRAM for cache.

As far as peripherals, the CC2650 has four 32-bit timers, which can be divided further into eight 16-bit timers, each being able to be pulse width modulated. It also features an 8-channel, 12-bit ADC, capable of up to 200 ksamples per second. This MCU also has a unique feature: a programmable current source.

Figures 27 and 28 outline a reference design for the general setup of the CC2650 chip, and its corresponding transmission and receiving network ultimately terminating in an antenna.

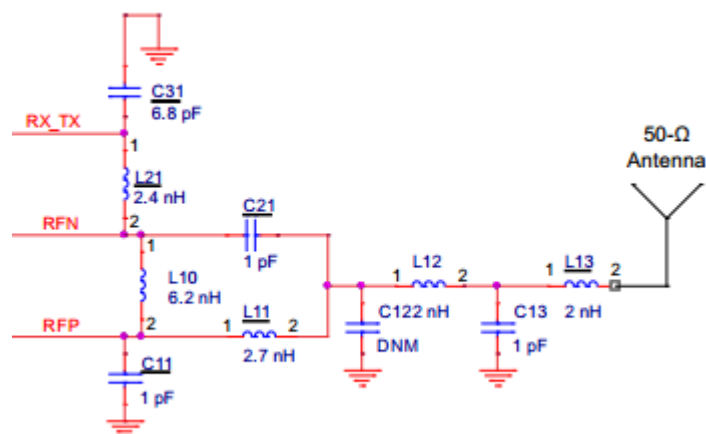

Figure 27: BT Passive Filter Antenna Schematic

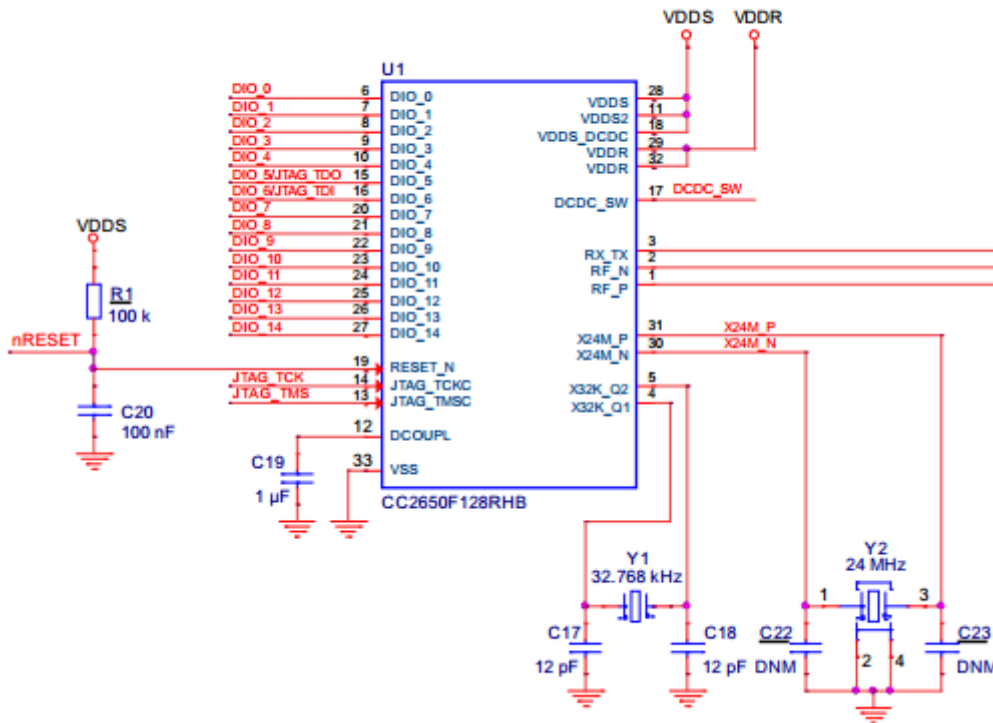

Figure 28: CC2650 Clocks and Power Schematics \*

Several other design components discussed, including the switching regulator and voltage level shifters discussed in later may also be ported for use in this design as well, as the input voltage for the CC2650 is between 1.8 V to 3.8 V. For these reasons, after thorough research of the part, the original solution of a dual chip system was shelved in favor of the CC2650. The research of the original solution was maintained in this paper, however, for both historic value to Limbitless Solutions, and as an alternate solution should the need arise.

#### 4.6.4. Chosen Module Schematic

The module chosen is the CC2650. This solution is the most ideal in all areas, including board space, price, and ease of programming, as the data is being received by the controller itself, eliminating the timing issues and voltage level problems between chips. Additionally, use of this chip eliminates the need for a 1.8 V regulator, as the chip contains an internal DC-DC converter that has the ability to step down its own power supply to also fulfill the needs of the 1.8 V logic power supply. Illustrated in Figures 29 and 30 are the preliminary designs for the CC2650. Figure 29 contains the primary power connections and RF signal lines for the Bluetooth antenna, while Figure 30 demonstrates the bypass capacitor arrays for the 3.3V and 1.8V regulated lines. These connections form the base needs of the chip, and the additional peripheral connections will be handled in the final design portion of this document.



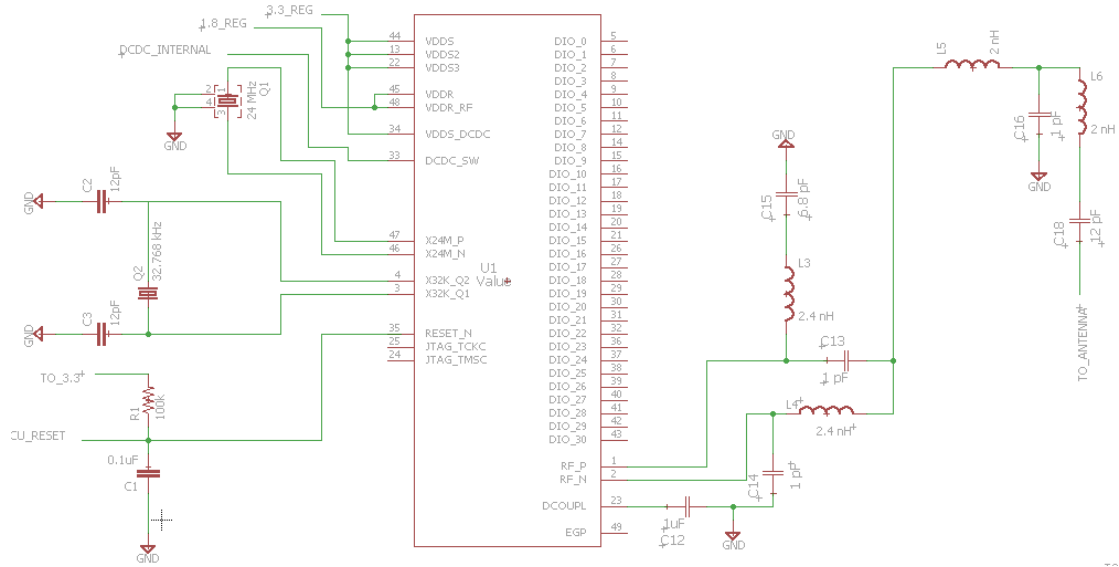

Figure 29: CC2650 Final Schematic

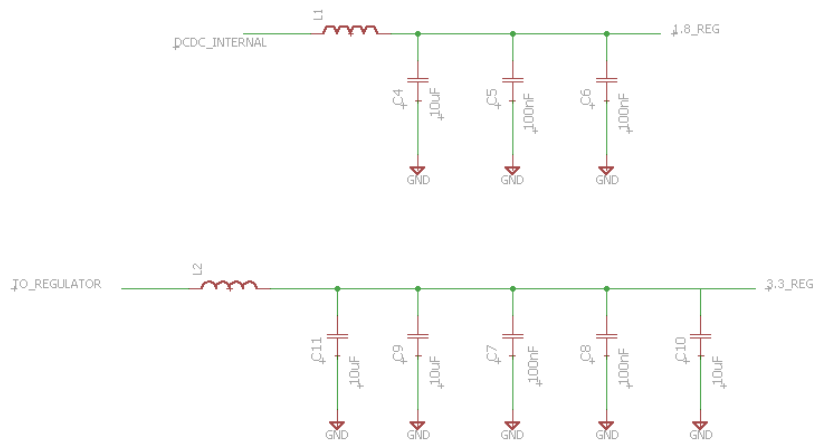

Figure 30: CC2650 Bypass Capacitors

## 4.7. Microcontroller (MCU)

Proper choice of an MCU lies at the heart of this project, as the choice needs to reflect not only the current build design, but must take into account all of the additional functionality that Limbitless hopes to include in the near future. For example, while the authors have not outlined any goals in this project in the way of additional degrees of freedom in the digits of the hand, it is a future goal of the client, and therefore an additional GPIO pin must be present for each finger.

The purpose of this section is to examine a number of shortlisted controllers from areas of importance to the project including, but not limited to communication protocols, wireless interface capabilities, pin quantities, timers, power requirements and dissipation, and most importantly, price. With knowledge of these various areas, a decision can then be made as to which controller is the correct choice for this project.

### 4.7.1. Voltage Regulation

Unlike the many evaluation boards and kits used throughout the learning processes, it became apparent that the chosen MCU will need a voltage regulator to maintain a steady voltage throughout operation. The two main classifications that will be examined are the linear and switching regulator. Switching regulators are advantageous in the ability to provide both boosts and bucks to the system, whereas a linear regulator may only buck the load down to the target voltage. Given that this system will only require the ability to regulate the battery voltage down to usable 3-4 V, the advantage of boost regulation is not required. Examining the two devices from the important views of size and cost, it has also been found that, on average, switching regulators are much larger than their simple alternative. Switching regulators function by applying a pulse width modulated signal rapidly across the gate of a MOSFET transistor, “switching” the system on and off, and maintaining the desired voltage by effectively transitioning across the average voltage multiple times per second. The disadvantage here is the generation of noise in the output, due to the ripple in the voltage this method creates. The size is also of concern, due to the need of an inductor for this circuit to work effectively, adding both footprint and weight to the arm. The cost of the linear regulator is also much less than that of its counterpart, due to the high need of external components by the switching regulator, including other integrated circuits and inductors, which greatly increase the circuit size.

From the gathered information, the group has decided to regulate its logic system through either a simple linear regulator, or switching regulator, based upon power analysis for the enclosure. Given that a battery size 7.4 V has been chosen, a regulator that provides 3.3 to 3.6 V will ensure that our MCU system is provided the correct voltage at all times. To handle the negative voltage regulation, if needed, solutions exist that will take an input voltage and return a negative of the same value, without need of a negative reference. An example of this, the

ICL7660, is a high efficiency device (98%) to accomplish this. The theory is that the regulated output could feed a channel through this device, thus resulting in two regulated, bipolar signals that may then be wired to the needed areas, such as the negative power terminal of any operational amplifiers used in the design. The circuit in Figure 31, with help from Webench, was designed to accomplish the above from a linear regulation standpoint, and will be integrated into the MCU section if found to be sufficient:

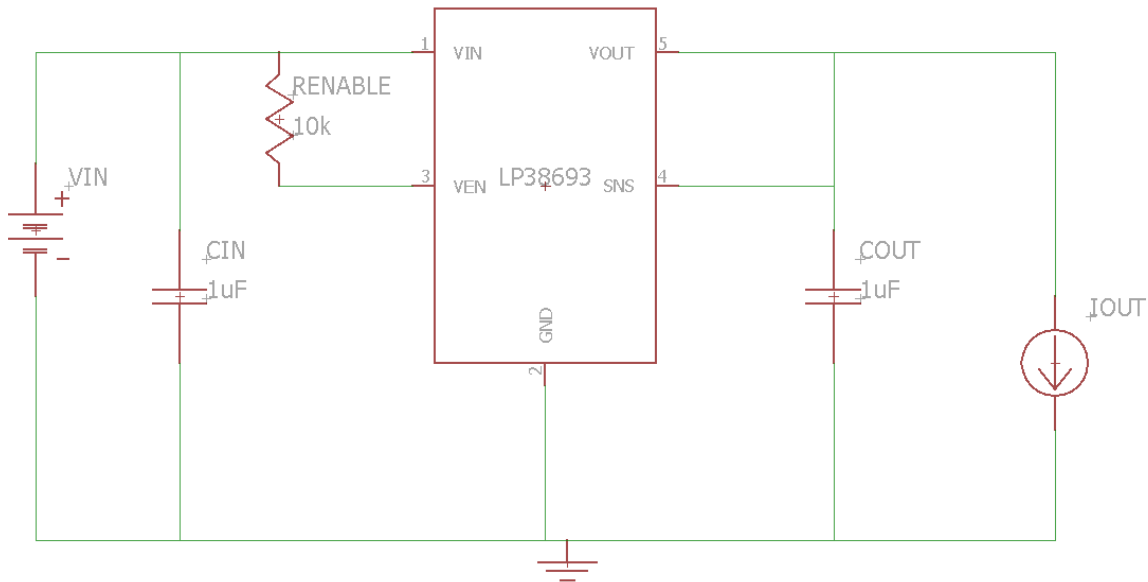

Figure 31: 3.3 V LDO Regulator

This circuit is designed to maintain a steady 3.3 Volt regulated  $V_{cc}$  for the MSP430FR5949. The chip comes with an enable port, but the Microcontroller will always need to be on while the system is use, so the enable pin has been directly connected to the input voltage as recommended in the data sheet, to ensure a constant on connection.

It has a rated efficiency at the moment of approximately 40%, which is low, even for a typical LDO. This will serve as a working prototype for the voltage regulation needs of both the MCU and the Bluetooth Module, with the team being able to change the design to a switching regulator if need be during the prototyping phase. While this may prove to not be an issue due to the low current required by these devices, power analysis may be required to examine the heat characteristics of this device due to the desire to enclose the PCB inside the housing at some point during the prototyping phase.

However, the circuit that will more than likely end up being used is found in Figure 32. While the linear regulator makes the most sense from a price and footprint point of view, the largest issue with regulation here comes from the desire to enclose the housing, including the need to make it water resistant. This means that heat must be kept in check inside the enclosure, with the regulator being one of the most

intensive areas for power dissipation inside the current schematic. Therefore, with an efficiency rating of only 40%, the LDO given above will produce a tremendous amount of heat, which normally could be controlled through a heat sink. However, sealing of the electronics housing would cause this to be a problem, with the heat spreading to the entirety of the space, and possibly causing instability in the electronics. The design below solves this problem through a high efficiency buck converter at the expense of noise in the output voltage, due to the ripple across the inductor. This can be kept in check though, with appropriate filtration.

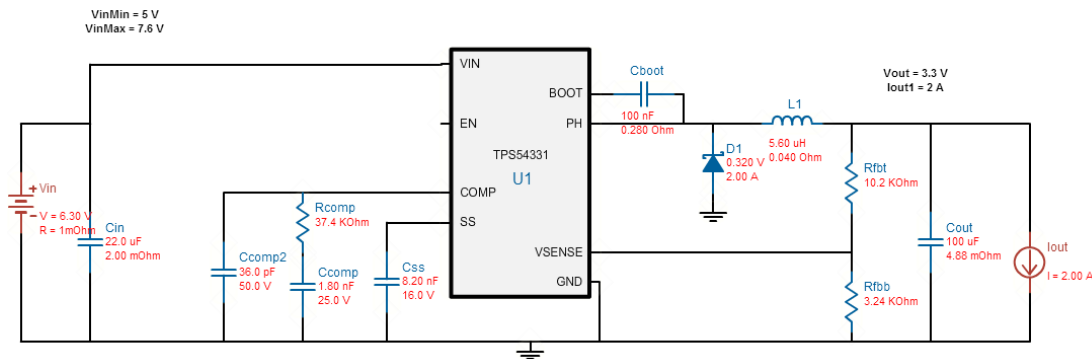

Figure 32: Switching Buck Converter\*

## 4.7.2. MSP430FR5969

The MSP430FR5949RHAR is an FRAM featuring microcontroller made by Texas Instruments (TI). Available in VQFN (6mm x 6mm) or TSSOP (12.5mm x 6.2mm) packaging, this microcontroller is reasonably inexpensive, costing a reasonable \$5.06 per device ordered, with price breaks being available for multiple buys. It employs TI's 16 bit RISC architecture, typical for their MSP430 family, which is an advantage to the authors, as all four have prior experience operating inside this environment, and the device is supported in code composer studio, which all have operated inside of before. This would create a learning curve, however, for future work by the engineers of the Limbitless team, as the current standard used for the arm is the Arduino programming environment. This could be seen as an advantage however, as the embedded systems coursework covered at the University of Central Florida is based in Code Composer Studio, and therefore all engineering students should be versed in this program at some point in their academic careers. The chip is also extremely peripheral friendly, featuring 33 general purpose input/output pins, a 12 bit analog to digital converter, capacitive touch screen capabilities, and the ability to use I<sup>2</sup>C, SPI, and UART serial protocols.

A major innovation that this chip would provide is the introduction of Ferroelectric RAM (FRAM) to the system, which is a new innovation from Texas Instruments. This new technology is similar to flash memory due to its non-volatile nature. It is advantageous over flash, however, as it is more robust in its number of write cycles, features faster write performance, and, most importantly, requires less

power. This technology is also useful to this application in the fact that it is unaffected by magnetic fields. Children are creatures of curiosity and the arm will be subjected to various stresses as the device is put through its paces. In addition, the authors are also examining ways to use magnetic induction to wirelessly charge the device. As such, the protection of data inside the device is paramount to ensure it continues to work properly inside its environment. FRAM, being impervious to magnetic fields, removes one of many concerns in the area of data integrity. It also unifies the data into a single area, combining the program and data in a single area. The logical flow of this microcontroller is mainly across a single bus which feeds into its own controller. This bus greatly simplifies the data flow, allowing nearly all areas of the MCU to communicate with each other as needed. Given that a primary goal of this project is the ability to push data into the program section of memory, this simplification is highly prized in a MCU choice.

The chip itself is also part of TI's low-power family, with the most demanding power cycle of the MCU being its active mode, in which the chip draws  $100 \frac{\mu A}{MHZ}$ . This would indicate that while the arm is in use, if the system is run at an arbitrary clock speed of 8 MHz, the draw on the batteries by the microcontroller would only be 0.8 mA. If it can be harnessed for benefit, this MCU also features a low power mode that effectively puts the MCU to sleep until an interrupt is triggered, i.e. a flex is detected. If this is viable, the consumption in this mode drops to  $0.4 \frac{\mu A}{MHZ}$ , or  $0.32 \mu A$ . A summary of these desired traits and features is given in Table 10 below:

Architecture	16-bit RISC
Smallest Footprint	VQFN (6mm x 6mm)
Input Voltage Range	1.8 V - 3.6 V
Power Consumption, Active Mode	$100 \frac{\mu A}{MHZ}$
Power Consumption, Standby	$0.4 \frac{\mu A}{MHZ}$
Maximum Clock Speed	16 MHz
SPI Pins	up to 8 Mbps
PWM	5 timers, 7 channels each
GPIO	33
ADC	12-Bit
Price	\$5.06 from Texas Instruments

Table 10: MSP430FR5969 Characteristics

### 4.7.3. ATmega328

The ATmega328p is the current MCU implemented in the Limbitless Arm. A common processor found on the Adafruit Trinket pro, its features are quite similar to that of the above discussed ATtiny828. It is also simpler than many of the controllers listed, with an 8-bit reduced set instruction architecture (RISC) capable of up to 20 MIPS at 20 MHz. A major difference here however, is that it is capable of having up to 32KB of non-volatile memory that is self-programming. While useful, this is probably not necessary, as the MCU will still require a module capable of receiving the instructions via over the air programming.

The ATmega is also equipped with up to 1KB of electrically erasable programmable read-only memory (EEPROM), and comes equipped with an in system boot-loader. This chip also has the capability of locking the software for security purposes. While hacking or software penetration are not high on the list of foreseen issues for this project, meddling by parents has been identified as a top priority, and this feature may be useful for preventing more technologically inclined parents from attempting their own modifications and solutions.

Examining the pin structure of the MCU, it contains an additional timer over the ATtiny, and has six PWM outputs, which is sufficient for future growth in the arm. The package comes equipped with 23 programmable input and output lines, and, unlike several of the other MCUs analyzed here, has the ability to come in a simple DIP package if desired. This is non-ideal from a footprint standpoint however, as several of the other packages are much smaller. The programmable pins are able to support multiple communication protocols, including SPI, UART, and I2C, all of which have considerations in the final schematic. Power is also not as good as several other MCUs, drawing  $0.2 \frac{mA}{MHz}$  of current in active mode, and  $0.75 \frac{\mu A}{MHz}$  while in standby mode. Finally, this MCU is less costly than several of the others examined, with the average located price before shipping being approximately \$4.00. These metrics have been summarized in Table 11 below:

Architecture	8-Bit
Smallest Footprint	VHHD: 5.00mm x 5.00mm
Input Voltage Range	1.8 V - 5.5 V
Power Consumption, Active Mode	$.2 \frac{mA}{MHz}$
Power Consumption, Standby	$.75 \frac{\mu A}{MHz}$
Maximum Clock Speed	up to 10 MHz (for chosen range)
I2C Pins	up to 400 kbps
SPI Pins	no transfer rate statement made
PWM	up to 6 pins
GPIO	23
ADC	8-channel, 10-bit
Price	\$4.00 from Mouser Electronics

Table 11: ATmega 328 Characteristics

#### 4.7.4. ARM Cortex M3

The ARM Cortex is the most capable MCU on the list, with a full 32-bit instruction set architecture. As such, they are also the most expensive, with a price tag of approximately \$7.00 per chip for an ARM type processor. Built on a 3-stage pipeline, this microcontroller incorporates three separate data buses for instructions, data, and peripherals:

The chip is capable of running speeds up to 100 MHz, and also includes a memory protection unit, which among many other purposes, restricts access permissions to rewrite memory sections in the block. The chip is can be ordered with up to 32 KB of SRAM, which can be used for data or instruction storage, as well as Ethernet and USB data. The chip also comes equipped with a direct memory access chip (DMA). The DMA is a microcontroller subsection that allows the central processing unit to continue working during a data fetch operation. In most cases, the CPU is engaged the entire time a memory request is given, and only continues operation once the fetch instruction is completed. Equipped with a DMA, the CPU simply initiates a data fetch request to the DMA, and then continues to execute other

instructions. The DMA then sends an interrupt to the CPU when the memory has been fetched to notify the CPU that the data is there.

The chip boasts 4 UART capable pins, with integrated modem control present in the first of these pins. In addition, the M3 also boasts multiple SPI ports, capable of programmable word size. There are also 3 enhanced I2C ports capable of data transmission up to 1 MB/s.

Ultimately, while the authors felt it necessary for due diligence to examine a higher level chip, the authors have determined that this chip is far too large, overqualified, and too expensive for the needs of this project, and thus removed it from consideration for the chosen MCU. Given in table 12 below, the abilities of this chip far exceed the needed parameters of a microcontroller for this project, and the additional features equate to nothing more than additional cost that is not needed for this product. Furthermore, BGA consists of one of the most difficult components to hand solder without the aid of specialized equipment, such as a pick and place machine, which, at this time, Limbitless does not have. This would mean that repairs to the MCU could not be completed in house at this point in time, and the work would have no choice but to be fielded to another company. Given the relatively simplistic nature of the data being passed and required states, there is no need for a MCU of this magnitude.

Architecture	32-Bit
Smallest footprint	100 ball BGA: 9.00 mm x 9.00 mm
Input Voltage Range	1.62 V - 3.6 V
Power Consumption, Active Mode	no general statement made
Power Consumption, Standby	no general statement made
Maximum Clock Speed	up to 100 MHz
I2C Pins	up to 1 Mbps
SPI Pins	up to 1 Mbps
UART Pins	4, with modem control
GPIO	103
ADC	8 channel, 16-Bit
Price	\$7.00 from Mouser Electronics

Table 12: ARM Cortex M3 Characteristics



### 4.7.5. ATTiny828

The simplest MCU on this list, the ATiny828 is an 8-bit MCU which is reasonably complex for its small size. It operates on a RISC architecture that still features 120+ instructions, with a potential throughput of up to 20 MIPS/sec. This will be limited, however, by the operating voltage of the MCU. If limited to 3.3 V, the speed at which the MCU can be controlled is relegated to between 0 and 10 MHz. This processor also requires more energy to run, requiring  $0.2 \frac{mA}{MHz}$  at only 1.8 V. This controller does, however, also include a standby mode, which reduces the current load to  $0.03 \frac{mA}{MHz}$  at 1.8 V. In both of these cases, it is inferred that the power consumption would be far greater at 3.3 V, which may cause attainability issues with the desired battery metrics sought by this team. This chip also only contains one 16-bit timer. From previous projects, the authors realize that while this may be sufficient for the current build, where only one servo controls all five fingers, this will cause an issue when multiple servos are attempted to be integrated, as only four may be controlled by this timer pulse width modulated pins.

Memory management would be a challenge with this choice, as the only memory present on the device is 256 bytes of EEPROM, 512 bytes of SRAM, and 8 kilobytes of flash. While it may not present a large issue, write cycles are predominantly lower than other choices, limited to only  $10^4$  write cycles. There are two on board timers, one 8-bit and 16-bit, each tied to 2 pins capable of pulse width modulation, for a total of 4. The total number of input and output pins allowed is 28, with high current drive capability on 8 of those pins.

An advantage of this chip would be the ability to continue working in the Arduino integrated development environment (IDE), which is the current IDE used by Limbitless solutions. This would prevent the undertaking by their current engineering team to switch software platforms, and allow them to continue to easily program in a language they are already versed in. However, given the relationship between Texas Instruments and Limbitless Solutions, it would seem that a solution by Texas Instruments is preferred to Atmel. In summary, Table 13 gives a listing of the desirable criteria below:

Architecture	8-bit RISC
Smallest Footprint	MLF: 5.00 mm x 5.00 mm
Input Voltage Range	1.8 V - 5.5 V
Power Consumption, Active Mode	0.2 mA, @1.8 V, 1 MHz
Power Consumption, Standby	30 $\mu$ A, @1.8 V, 1 MHz
Maximum Clock Speed	10 MHz (for chosen power range)
SPI Pins	up to 25% of the input clock
PWM	2 timers, 2 channels each
GPIO	28
ADC	10 - Bit
Price	\$2.39 from Mouser Electronics

Table 13: ATTiny828 Characteristics

#### 4.7.6. Chosen MCU Schematic

The microcontroller originally chosen for the project was the Texas instruments MSP430FR5969. Given the client's relationship with Texas Instruments, and the current curriculum at the University of Central Florida, it made sense to opt for an MCU that operates in an IDE that all ECE students that might join the Limbitless team will have experience in. Operation in this IDE also would have served to benefit future students wanting to further develop this electronics package. While slightly more expensive than the current solution, the MSP430 is by far the lowest power consuming MCU listed above, and its footprint is on par with the ATmega328 currently used. Integrating the MCU alongside the CC2560 to handle Bluetooth communication, the MCU block diagram could be pinned out as shown in the figures below.

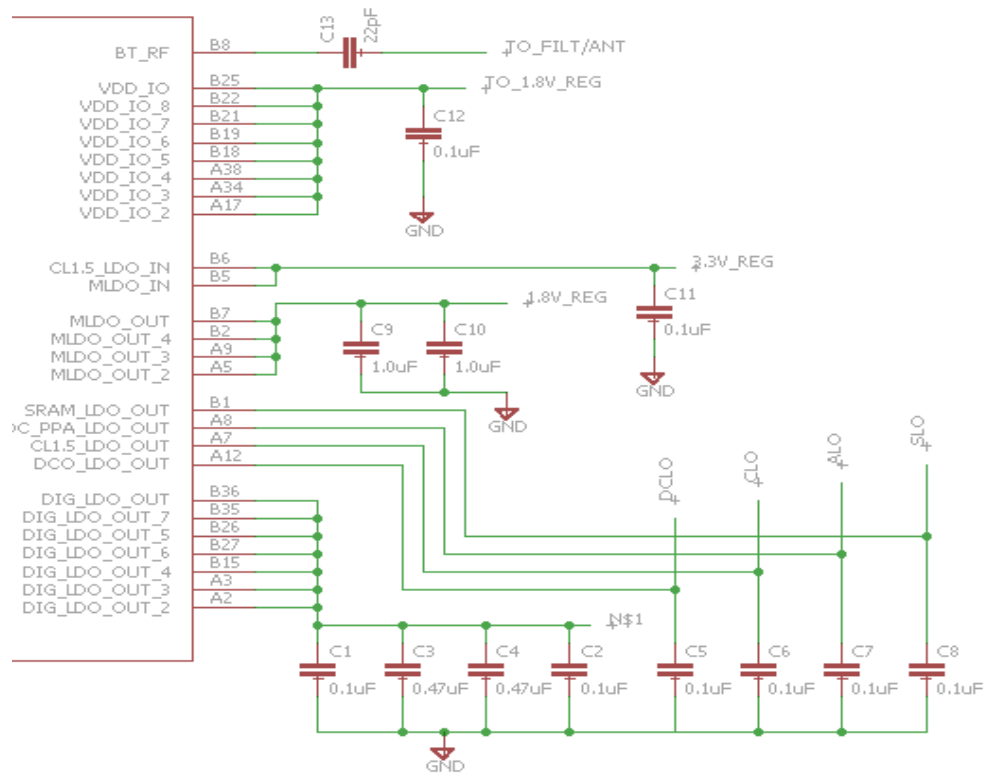

Figure 33: CC2560 IO Schematic

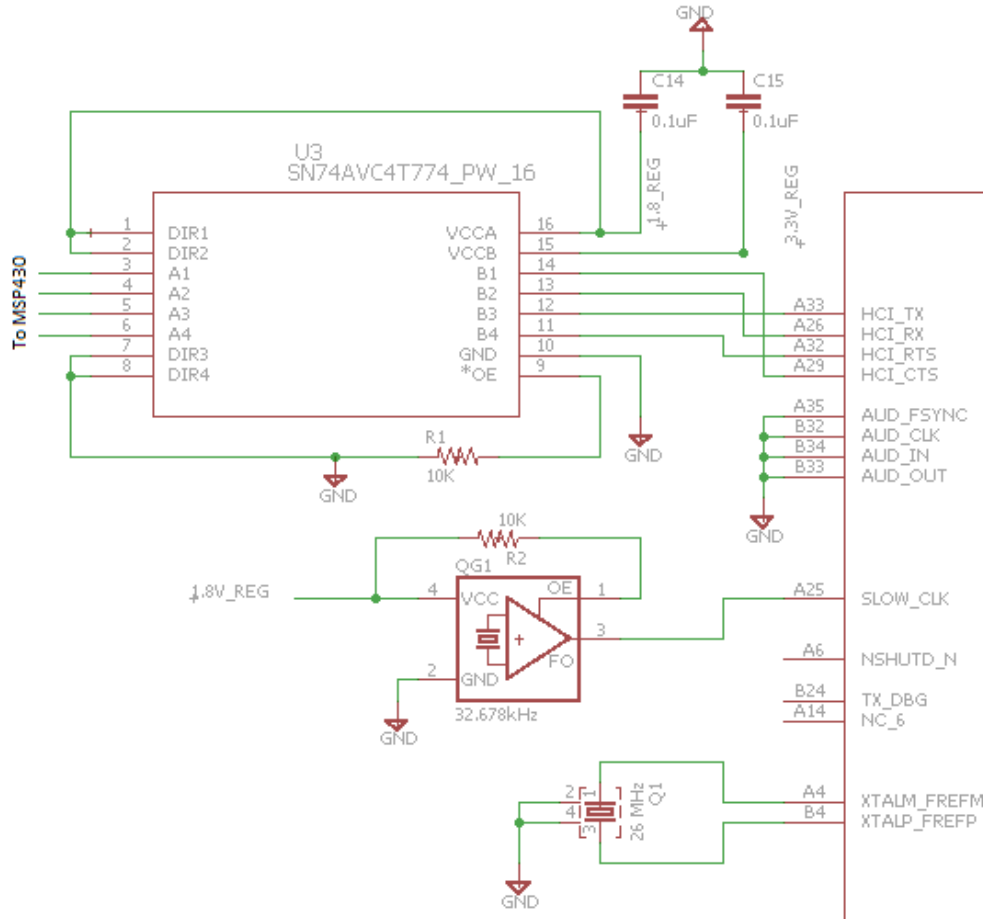

Figure 34: MSP430 Connection to CC2560

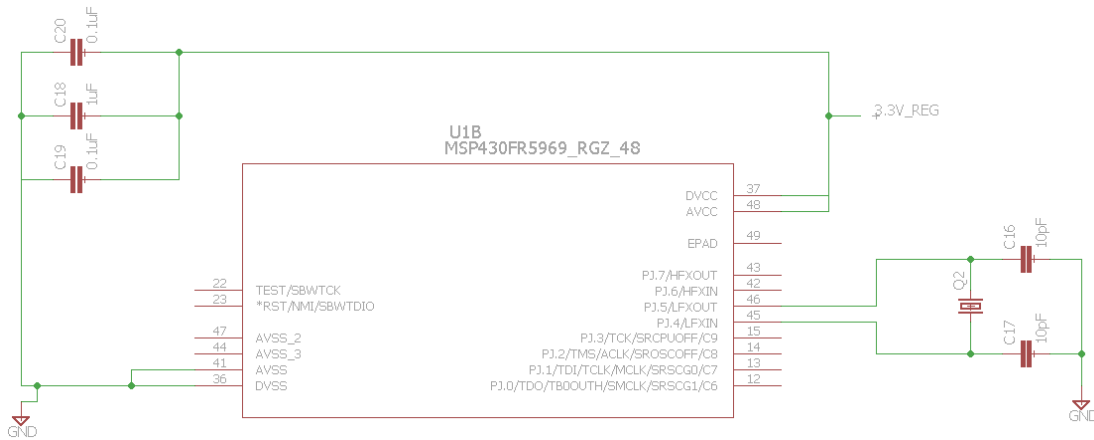

Figure 35: MSP430 Power Schematic

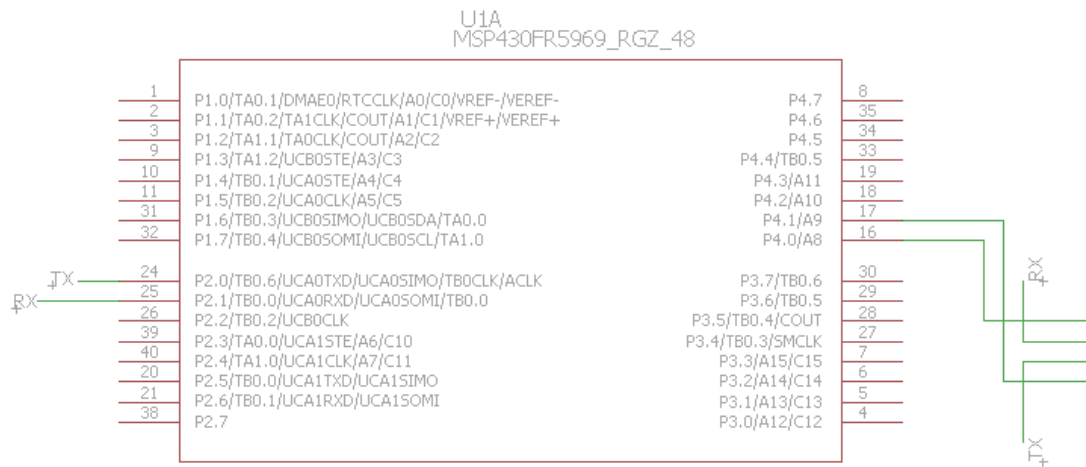

Figure 36: MSP430 IO Schematic

It should be noted though that this is an alternate solution. Comparing the schematics, it can easily be seen that there is a simple elegance found in the final solution of the CC2650 serving as both the Bluetooth module, as well as the primary MCU of the system. Success of this solution would eliminate the need for a second chip, saving in the realms of both cost and space, as well as reducing power consumption in the circuit and number of active components needing to be programmed during the prototyping phase of this project. However, as this work was completed prior to changing components, it is being left in this document for potential future use by Limbitless if they wish to make changes to their package for the benefits outlined in this section.

## 4.8. Electromyography Sensor

Electromyography is reading the voltage produced by motor neurons when they are activated by the brain. In medicine, this can be used to ascertain the health of muscles and the neurons that control them. For this project, electromyography is only used to read whether or not a muscles is flexed.

Other techniques exist that allow the act of a muscle flexing to be transduced into an electric signal that could be used such as electrocardiographic and electroencephalographic sensors. Electromyography is the least intrusive of these methods (meaning that the other technologies can be uncomfortable to the user) and is the best researched for our application. Electromyography is usually used to measure minute changes in muscle health so the sensors have very high resolution and precision. These sensors have more processing power than is needed for this project. They are still acceptable to use, but they will be severely underutilized.

The signal coming from the muscles is roughly 1-10 mV, and 50-400 Hertz. This is a very small signal to start, but taking into account the large amount of noise that will come from the electrodes and the skin (if surface electrodes are used), this signal can be extremely difficult to detect. Detection requires the use of very sensitive amplifiers that have high Common Mode Rejection Ratio (CMRR).

### 4.8.1. Analog Approach

Currently, The Limbitless Solutions electronics use an analog approach to acquire and filter the raw signal from the muscles. In the background section of this document, the exact circuit that is used is described in depth.

In general, what is needed to create an analog Electromyography sensor is a high Common Mode Rejection Ratio Amplifier for signal acquisition, a Bandpass filter for signal processing, a rectifier to make the signal entirely positive, and a simple amplifier at the end to give the desired magnitude.

The acquisition amplifier is arguably the most important component of the Electromyography sensor. This part needs to have a Common Mode Rejection Ratio of at least 90 decibels in order to properly acquire the signal. The magnitude of the gain can vary from 500 to 10,000 depending on the muscle being measured. In this project, either the forearm or the bicep will be used so the gain can be on the lower end. But since the target users are children, who have smaller muscles than adults, the gain will need to be somewhat larger than it would be for an adult. With this in mind, the gain should be around 750-1,500.

Since the signal is typically measured in a bipolar fashion, the amplifier is usually some form of instrumentation amplifier such as the AD8226. Two of the probes are placed on the muscle group being measured and the third is placed on an inactive

region of the same limb. The two sensing probes feed into the two terminals of the instrumentation amplifier and the other probe is connected directly to ground as a reference. This is shown in Figure 37 below.

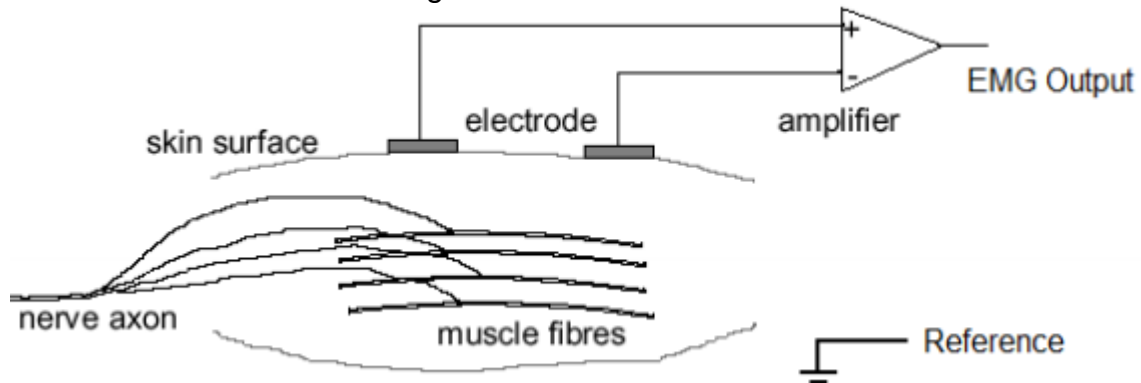

Figure 37: EMG Electrode Placement#

After the raw signal is amplified, it can be passed to the filtering components. The majority of the raw signal of the muscles is in the 50-150 Hertz range. In order to capture as much energy as possible, most Electromyography papers suggest using a Bandpass filter with a range of 50 to 500 Hertz. Active filters are suggested for use due to their better rate of roll-off and lower noise. Figure 38 is an example of a common Active Bandpass filter used for Electromyography sensors.

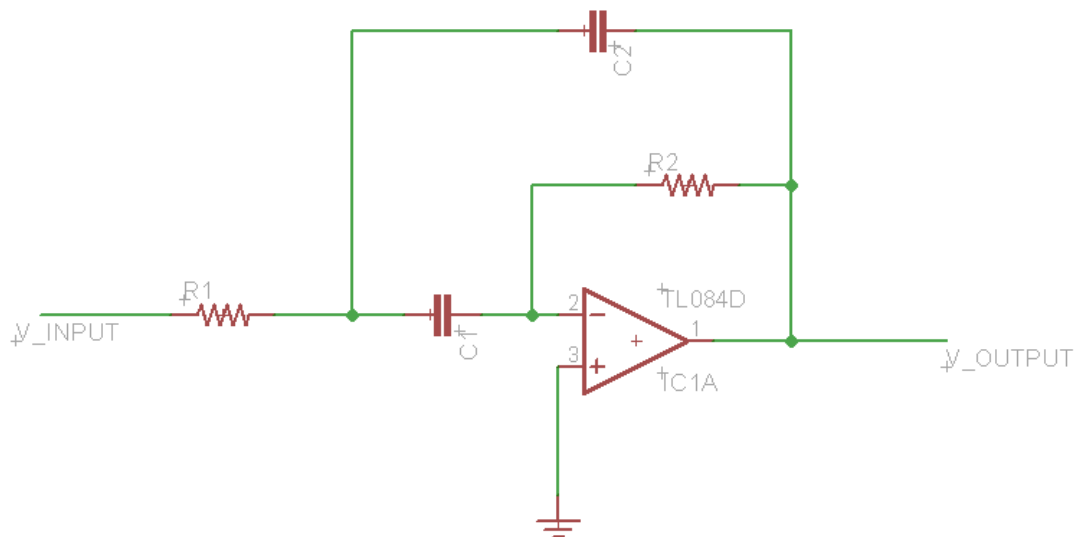

Figure 38: Active Bandpass Filter Schematic

After the signal is properly amplified and filtered, it needs to be rectified. With the analog to digital converters that are being investigated for use, the input voltage needs to be positive. As such, a full wave rectifier needs to be used to preserve the entire signal. Precision full wave rectifiers are suggested as they have the

lowest noise and attenuation of the original signal. Often times, after the signal is fully rectified, a low-pass filter is used as an “envelope detector” to smooth out the signal. This low pass filter typically has a cutoff frequency of 100-200 Hertz. This will make the signal much closer to being a true DC signal.

Finally, a simple amplifier is used to compensate for any attenuation in the filtering or to invert the signal if needed (depending on the types of filters used, the signal can be inverted at the end of processing). This is typically a basic inverting or noninverting amplifier with a potentiometer used for adjustable gain. The potentiometer allows the user to compensate for any day-to-day changes in muscle or skin conditions.

### 4.8.1.1. General Circuits

Figure 39 below shows a very high level block diagram of the general circuit used for an Electromyography Sensor.

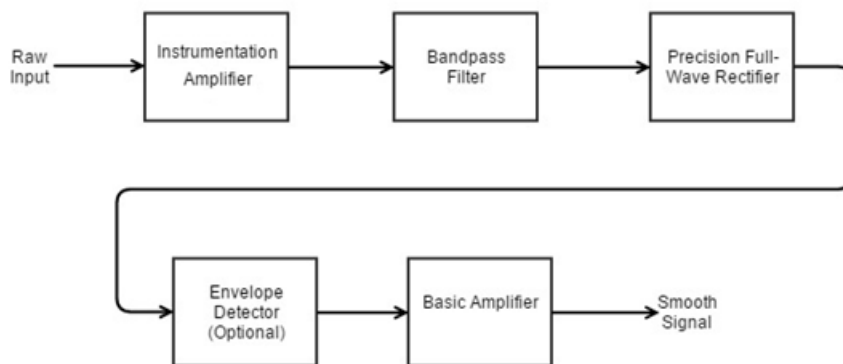

Figure 39: EMG Sensor General Circuit



## 4.8.2. Adding Multiple Inputs with Analog Approach

A large part of this project is creating a set of electronics that will be relatively “future-proof” for Limbitless Solutions. As such, Limbitless Solutions expressed that they would like the new electronics to have the ability to have multiple Electromyography inputs.

With the current design, there is only one input (as discussed in the “Background” Section). This severely limits the amount of control the user has. Without making the control too complicated, the only realistic input is akin to a momentary pushbutton: The user flexes and that is registered as a button press. With multiple inputs, significantly more complicated actions can be used. Multiple actuators can be controlled independently, different hand positions can be selected, and much more. Adding this capability opens the door for many more improvements to the Limbitless Solutions arm.

In talks with Limbitless Solutions, the directors have said that they would like to have at least three - four Electromyography inputs available. As such, the team is aiming to design the electronics with a minimum of three Electromyography inputs.

This section will talk about adding multiple inputs to the typical Analog Approach discussed above.

### 4.8.2.1. Duplicates

The most basic way to add more inputs is to create multiple copies of the same circuit. This design has many advantages. It will prevent any “cross-talk” or interference between the inputs because every circuit will be entirely separate: the only common element between them will be a ground line. This is also a fairly robust design because if one sensor fails, it will have no effect on the other sensors. Finally, the design is very simple which means it would be much easier to build.

The main disadvantage of this design is the size of it. The current Electromyography sensor module is roughly 2.5 centimeters by 2.5 centimeters in size. Adding X more sensors would take up exactly X times the size as the original circuit. This is a very poor design in terms of space. Seeing as form factor is one of the major components of this project, this design is not feasible to use. Another large disadvantage is that this approach will take up X times the power consumption as one analog Electromyography sensor. Since battery life is another major goal of this design, the duplicate design does not seem to work for this team.

## 4.8.2.2. Channels

Since size is the main issue with adding multiple inputs to the analog approach for the Electromyography sensor, the use of channels is a tempting idea. The idea behind channels is to use a single analog circuit to do the processing for all three (or four) raw signals. This is accomplished by using a switch box to rapidly switch between all the inputs and the outputs as depicted in Figure 40 below.

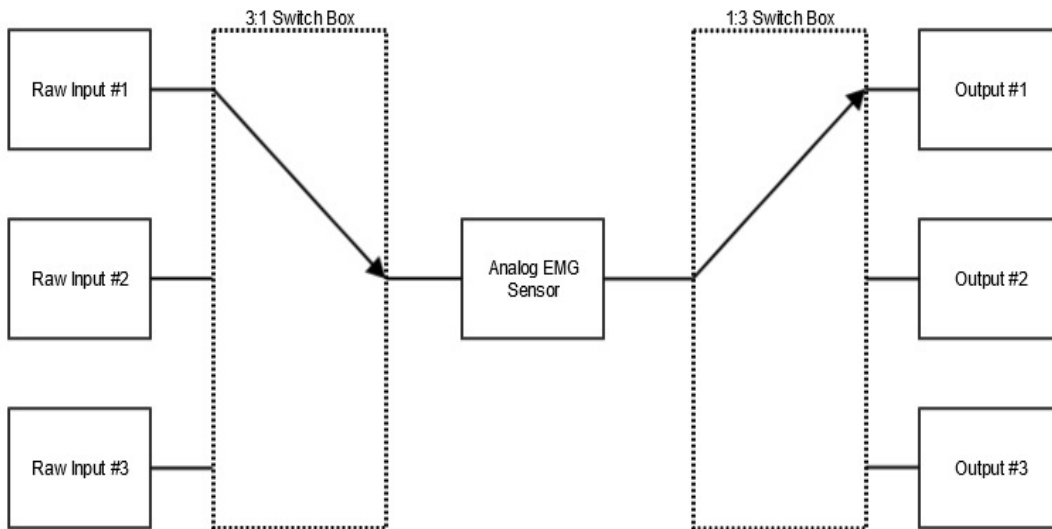

Figure 40: Switch Box Integration

This approach is used in some Analog to Digital Converters to save space and power. By rapidly switching between which signal is input to the sensor, the filtering can be “time-multiplexed”. This will allow the use of only one copy of the Electromyography sensor. This solves many of the disadvantages of using duplicate analog Electromyography Sensors: This will use less power and take up significantly less space than using duplicates.

This approach does have its downsides. The resolution of the signal will likely be reduced as the “Start-up” time of the filtering will make the first part of each segment of the output incorrect. The outputs will also be sampled rather than continuous. The software will likely be able to handle this, but it does present another drop in signal quality. Most importantly, this approach is very difficult to design. Picking the correct switching frequency and setting up the time constants in the sensor to match correctly to allow for proper signal quality is almost an entire senior design project in and of itself. As such, this method will not be used.

### 4.8.3. Use of Programmed Digital Filter

Another approach is to amplify and rectify the raw signal and pass it directly into an Analog to Digital Converter on the Microcontroller. The Microcontroller will then read this signal and perform Digital Filtering on it in the software.

This approach has many advantages. Software that will perform Bandpass Filtering (the type of filtering needed for Electromyography) is readily available online for use. It will use very few peripherals to prepare the signal to pass into the microcontroller. This will reduce form factor and power consumption greatly. This approach will also be infinitely reconfigurable. Since all filtering is done in software, it is very simple to change the cutoff frequencies and rate of roll off.

There are also disadvantages to this approach. Since all the filtering is done in software, it will take up a lot of processing power on the microcontroller. The microcontroller will be tied up doing the filtering for the majority of its operation which will reduce the number of auxiliary functions it can do per unit time. It is also difficult to choose the cutoff frequencies because the signal will have to be rectified (the analog to digital converters on the microcontrollers that have been looked at only work for positive voltages) which will change the frequency response of the raw signal greatly. To a point where all the research into the raw signal will be useless. Because of the disadvantages listed, this approach is not the ideal way to execute the Electromyography sensing.

### 4.8.4. Use of Analog Front End

Analog Front Ends (AFE) are typically used in conjunction with microcontrollers to acquire and do some preliminary processing of analog signals. Texas Instruments has a family of medical Analog Front Ends specifically designed for Electrocardiograms (ECG or EKG) and Electroencephalograms (EEG). These same chips should be easily reconfigurable to be used for Electromyography.

After some preliminary research, an Analog Front End will be used in the initial design for this project. The rest of this section will be used to detail the selection process for which Analog Front End to use.

Using TI's Search function, several possible Integrated Circuits were found. In table 14 below, the top four choices are shown with some important characteristics.

Part	Power (mW)	Bipotential Channels	Price	Evaluation Board
ADS1292	0.7	2	\$4.65	Yes
ADS1293	0.9	3	\$5.50	Yes
ADS1194	3	4	\$7.80	No
ADS1196	3.6	6	\$11.35	No

Table 14: Analog Front End Devices

In this project, the team is planning to add multiple Electromyography inputs. Currently the Limbitless Solutions arm has only one input and has plans to add in other input to allow for elbow control. As such, the electronics should have at least two electromyography inputs. Another important parameter is power consumption since this will be a battery powered project.

From the parts shown, the two Integrated Circuits that come out on top are the ADS1293 and the ADS1194. These have a decent price point at roughly \$6.00 - \$8.00 and a very low power consumption. Coming in at three and four channels, both of these integrated circuits exceed the Electromyography parameters.

Since the ADS1293 has a useful evaluation board and lots of documentation, including a TI Webench plugin, it has a large advantage. The ADS1293 will be used in the initial design for this team's final project.

The ADS1293 is configured by setting values in various registers detailed in the datasheet. The documented configurations available online are only useful for Electrocardiogram applications. As such, finding the correct configurations to use for Electromyography will have to be tested with the evaluation module.

The ADS1293 needs very few peripherals in order to work. The majority of the "peripherals" are resistors used for pull-up or pull-down configurations and for impedance matching or capacitors used to filter noise on the power lines.

Figure 41 below is a representative schematic of the ADS1293 in use. It is easily seen that there are only around 6 resistors and 4 capacitors. In the configuration that will be used, there will be no need for an external clock.

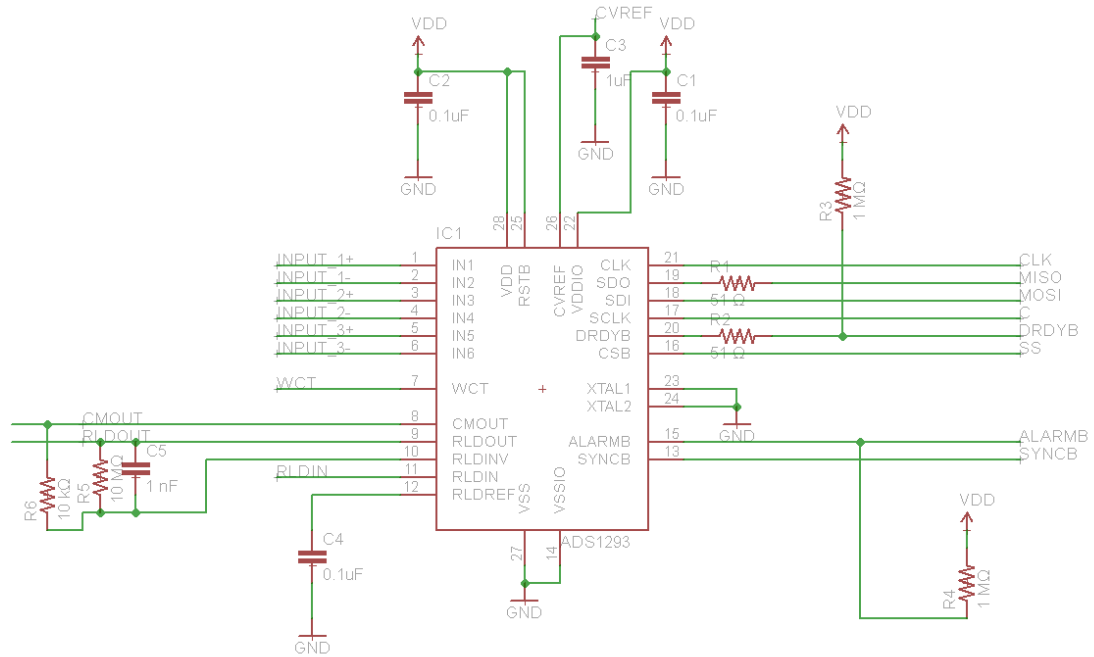

Figure 41: ADS1293 Schematic

## 4.9. Electromyography Electrodes

A major part of the Electromyography sensor is the electrodes that connect to the skin. This is the portion of the sensor that captures the raw signal coming from the muscle. At the time of acquisition, the signal is very small, usually around 10 mV. As such, the quality of the electrodes is paramount. If the connection with the skin is not solid, then the signal can be easily lost to noise. Also, the shielding on the cables is important as interference can easily mask such a small signal.

There are two major classes of Electromyography electrodes: Active and passive. Active electrodes have a pre-amplifier in them. This boosts the signal before transmitting it down the wire. This prevents interference since the signal is much larger than it would be unamplified. Passive amplifiers just pick up the raw signal and pass it down the wire. For the purposes of this project, passive amplifiers will be used since they are significantly more robust and less prone to failure.

### 4.9.1. Needle Electrodes

Needle Electrodes, shown in Figure 42 below, are usually typical needles that have conductive tips. These are inserted into muscles in the same placements as other electrodes. Needle electrodes are by far the most accurate type of electrode. They are typically used in clinical settings to measure muscle function.

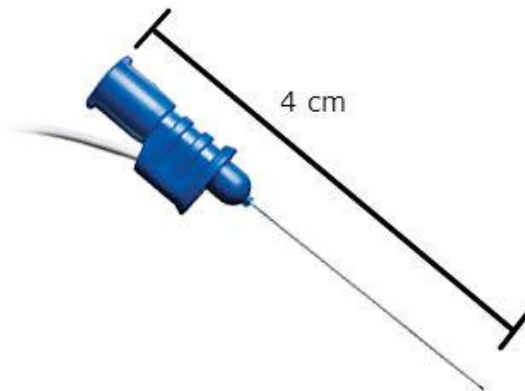

Figure 42: Needle Electrodes#

While they are the most accurate form of electrode, they are also the most intrusive. These electrodes are most definitely not recommended for frequent usage as they can cause permanent damage to the application areas. This type of electrode is most definitely not the kind that will be used in this project.

## 4.9.2. Disposable Surface Electrodes

Disposable Surface Electrodes, shown in Figure 43 below, are the type currently used by Limbitless Solutions. These typically look like stickers with a metal connector coming out of one side. The adhesive side is typically some form of gel. This aids in surface connection.

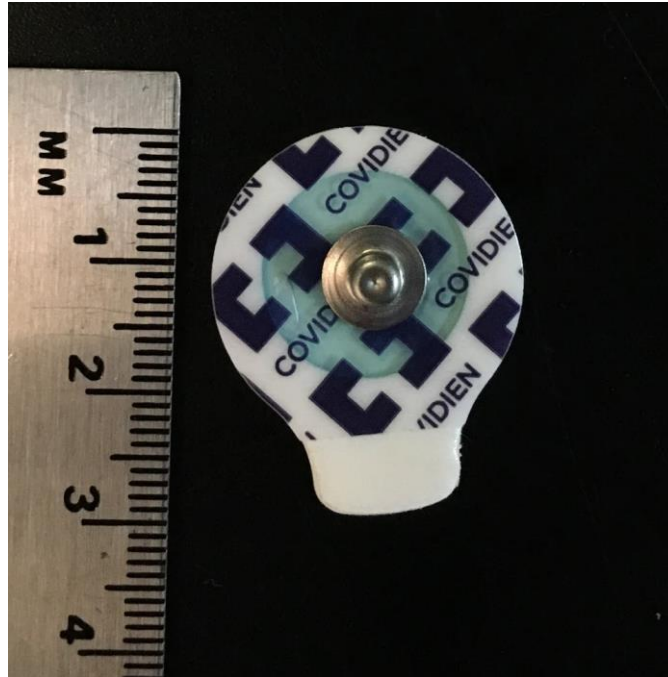

Figure 43: Disposable Surface Electrodes

These electrodes are the easiest to use. They offer the simplest usage of all the electrodes: The user just peels the sticker, places them in the correct place, and throws them away after use. On top of that, the gel adhesive gives strong skin cohesion and good signal to noise ratio.

The current plan is to use these electrodes for the final design. The main drawback to them though is their cost. They cost roughly \$0.33 per electrode. To use the arm, the user must use three electrodes per usage. This translates to roughly \$1.00 per use or \$30.00 a month to use the Limbitless Solutions arm. This cost is low enough that it is reasonable, but the team would like to reduce this if at all possible.

### 4.9.3. Reusable Surface Electrodes

Reusable surface electrodes, also called bar electrodes, are another option for signal acquisition. These are usually two conductive metal segments on some sort of plastic base. The metal sections are pressed into the skin to acquire the signal. Figure 44 below is an example of bar electrodes.



Figure 44: Reusable Bar Electrode<sup>#</sup>

These electrodes offer worse signal than the non-reusable electrodes, but not by much. When the metal segments are pressed into the skin properly, they offer decent skin contact.

One of the main advantages to this type of electrode is that they are reusable. If they are cleaned properly after each use, they will last a significant amount of time. From a user standpoint, this is ideal. Rather than spending \$30.00 a month on electrodes, the user just cleans off one and keeps reusing it.

The team will acquire a set of bar electrodes and fully test them. If they electrodes offer similar performance to the reusable electrodes, the team will use them in the final design.



## 4.10. Code

Since not all hardware decisions are yet finalized and the final approach has not yet been tested, there will be no actual code written in this paper. Rather, an outline will be presented that shows what code needs to be written in as much detail as possible.

In the code for this project, the team intends to use as many pre-written libraries as possible. This will aid in software portability and ease of programming. If the team ends up writing functions specific to this program, a library will be written to contain these functions. Limbitless Solutions has expressed interest in a library to simplify their code so these goals will align.

The current plan is to use a Texas Instruments CC2650 microcontroller. As such, the code will primarily be written in C or some C variant (C++, C#, etc.) using Code Composer Studio (CCS) from Texas Instruments. It is possible that a few functions may be written in Assembly Language in order to get the needed functionality, but this will be kept to a minimum. Writing the program in C will make the code much more accessible to future developers as C is taught to all Electrical Engineering, Computer Engineering, and Computer Science majors at the University of Central Florida.

### 4.10.1. Flowchart

The flowchart in Figure 45 below is abstracted to a very high level. In real implementation, interrupts will likely be used to enter many functions, but in the flowchart it seems as if everything is running serially in a constant loop. This was done to simplify the flowchart and increase readability.

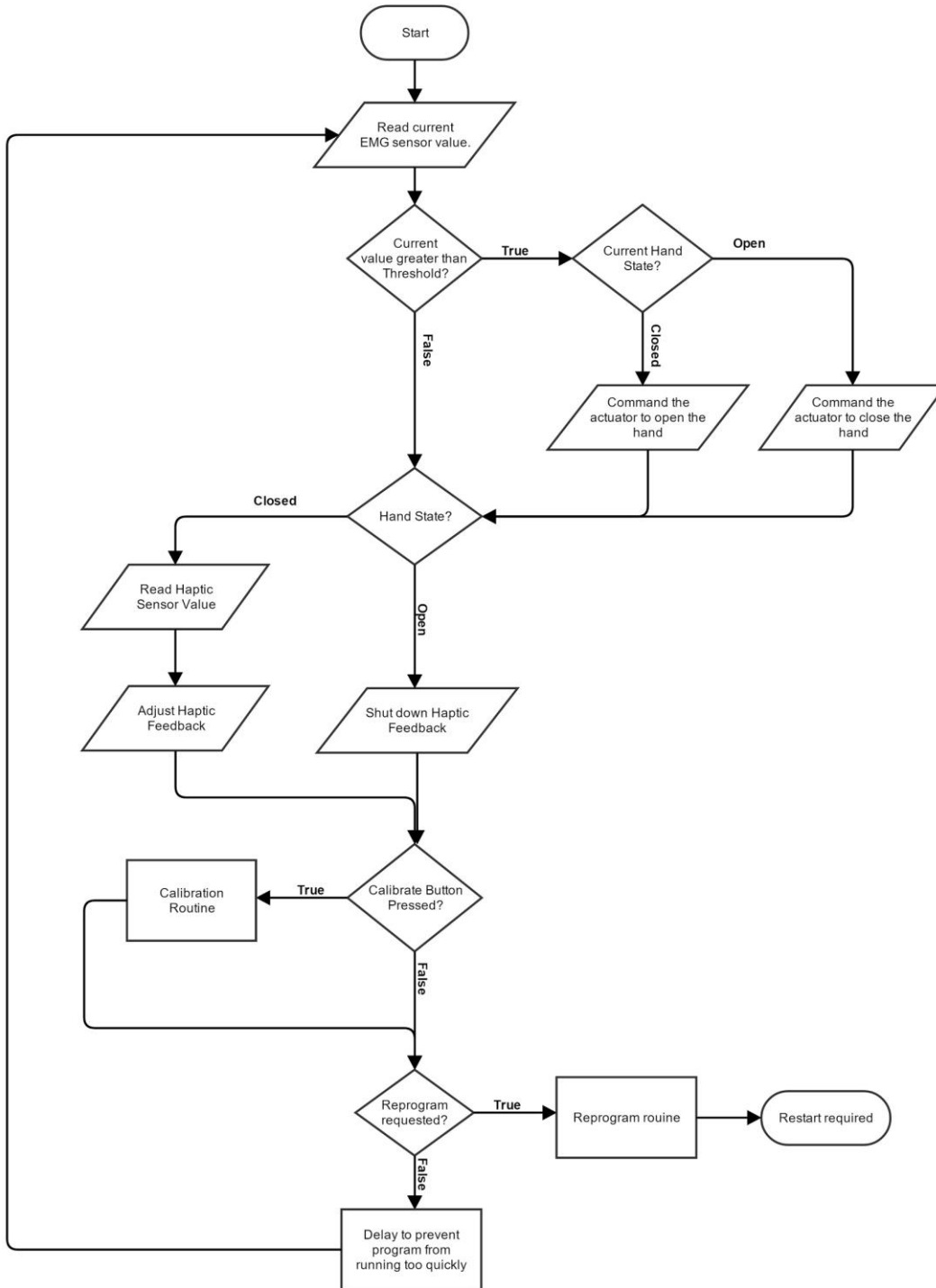

Figure 45: Flowchart for New Code

## 4.10.2. Libraries

Communication between the microcontroller and auxiliary Integrated Circuits will likely be done using both I<sup>2</sup>C and Serial Peripheral Interface (SPI). Libraries for both of these should be readily available for each protocol for any microcontroller chosen.

Since exact parts have not been chosen, the team is not entirely certain which exact libraries will be used. But since the team is planning on using all Texas Instruments parts, libraries should exist for all needed functionality between parts and the main Texas Instruments microcontroller. The parts that will likely need complex control from the microcontroller are listed below:

- Electromyography sensor
- Haptic Sensor
- Haptic feedback controller
- Actuator (servo) controller

For every part chosen, their corresponding libraries should be readily available.

## 4.10.3. Functions

Taken from the flow chart, table 15 below lists some of the functions that will need to be created and a brief description of their function.

Function	Description
Setup	Initializes all variables and sets up all control registers
Read EMG Sensor Value	Inputs values from all EMG sensors
Find Current Hand state	Returns the state of the hand (opened or closed)
Open Actuator	Communicates with the actuator and toggles the hand to the "open" state
Close Actuator	Communicates with the actuator and toggles the hand to the "closed" state
Calibrate Haptic Sensor	Calibrates the Haptic Sensor to the "empty" value
Read Haptic Sensor Value	Inputs values from Haptic Sensors
Adjust Haptic Feedback	Communicates with the Haptic feedback (motors, LRAs, etc.) to output a value corresponding to the Haptic Sensor Value
EMG Calibration Routine	Finds the threshold value of a flexed muscle from the EMG sensor. This value will be used to check if a muscle is flexed or not
Reprogram Routine	Sets up the microcontroller to be reprogrammed
Delay	"Pauses" the microcontroller for a set amount of time
Cleanup	closes out of any functions currently running and sets all states to initial values

Table 15: Needed Functions

#### 4.10.4. Support Hardware

To support the software, several inputs and outputs will be useful. At this stage, few specifics can be stated since the full implementation of the code has not yet been created.

In order to allow for easier communication with the user. Several Light Emitting Diodes (LEDs) will be needed in addition to a power indicating LED. For the initial prototype design, a very large amount of LEDs will be added. This will allow for simpler debugging and communication. After the program works correctly and the full program flow is fully flushed out, many of the LEDs will be removed. The team will try to find a balance that allows for the minimum number of LEDs to be used in order to save both power and board space.

The software will also need several momentary pushbuttons to allow for the software to enter subroutines like the calibration routines. Once again, for prototyping many buttons will be added. But once the final implementation is flushed out, this will be narrowed down to as few as possible.

## 4.11. Environmental Protection

Electronic components can be very susceptible to environmental hazards and stresses. Most electronics are encased within some type of enclosure that protects it from such hazards. The electronics housing of the current Limbitless Solutions Arm is an open package design. The hand is connected to the electronics housing and this structure can be taken out of the forearm that encases it. One of the aims of this project is to environmentally protect the electronics to ensure that they are not exposed to factors such as dirt, water, and ESD. The current design does not prevent these possible stresses from affecting the electronics. The team has researched methods for adding in methods of protection through conformal coating, shock resistance, and utilizing effective methods of heat dissipation.

### 4.11.1. Enclosure

As mentioned previously, the housing of the current electronics is not fully enclosed. Many electronic designs feature an unenclosed space for effective airflow distribution. Such designs are easily impacted by the effects of environmental stresses and in most cases can cause the components to malfunction. With the arm being used by a child, in its current state, the possibility of debris entering the electronics is rather high. The team will work with Limbitless Solutions Mechanical Engineers to redesign an enclosure that will be sealed off from outside forces. This newly designed enclosure will play a large role in the environmental protection of the electronics.

For this type of enclosure there is the concern dealing with airflow. Many electronics on the board are low power devices that are not running at all times. In a scenario of max load, the board could generate heat causing an internal stress within the enclosure. Methods for dealing with issue are discussed within Section 4.11.3.1 of this document.

#### 4.11.1.1. Robustness to Physical Shock

A major goal of the design is to produce a product that is robust. The intended customers are children who in most cases are rough with electronics. Many designs can malfunction due to physical disturbances through shock. Multiple instances of shock can be destructive to the design if precautions are not implemented. The housing shown in Section 3 (Figure 5), shows the design with loose components and jumper cables. A design of that nature can be impacted heavily by forces of shock and will fail frequently. The PCB, of the design, itself will improve the reliability of the product by containing the electronics running all functions of the board in one single interface. While this increases the robustness of the design, there are other factors to take into account.

Many PCBs will insert holes into the design for mounting purposes. This can be done to ensure that the PCB is fixed to the electronic housing that will be 3D printed. Without being fixed, the electronics will move frequently during use and are very likely to break or be damaged. The housing will be created to contain the majority of components. This enclosed space will provide some precautionary measures in case the arm experiences a forces of shock, such as the child falling or hitting the arm against an object.

The 3D printing material used in the design of the mechanical components of the arm, is very durable and should provide enough protection to ensure that the housing is not exposed to direct instances of shock.

### 4.11.1.2. Self-Containment

With the design of the 3D printed enclosure, the majority of the electronic components will be self-contained. Containing electronics within an enclosed space offers several advantages and disadvantages. Self-containment allows for the removal of external stresses.

In order to resist these stresses the electronics must be protected. Many quadcopters feature highly sensitive components and are in an airborne environment. For environmental protection for these components, many designs utilize shrink wrap. The material will shrink after being exposed to heat and create a protective layer over the electronics. This design feature can be utilized in the T.U.B.A for the purposes of improved dirt and water resistance. The wrap will cover the area of the PCB and extend over to the wires, where it will be further attached using epoxy to bind it to the wiring. Figure 46 demonstrates the use of the heat shrink wrap in this design.

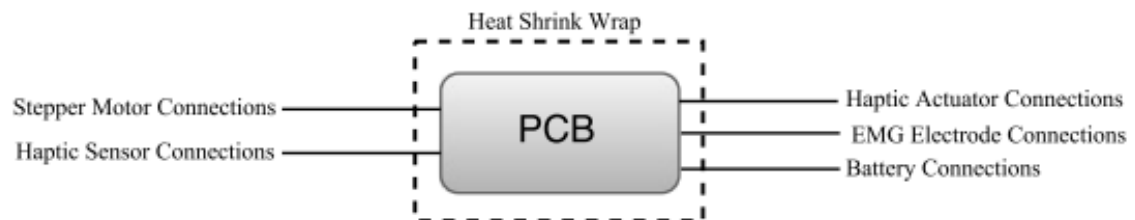

Figure 46: Shrink Wrap Diagram

The wrap will be applied around the PCB after conformal coating and will be shrunken around the surface using a heat gun or blow dryer. The open connections of the wrap after shrinking will be molded around the wires connected to the PCB and epoxied shut. As this feature removes the possibility of these external forces, the enclosure is now more susceptible to internal stresses. Methods for dealing with such stresses has been researched and taken into account the design. Additional information on the preventative methods of these disadvantages are discussed within the remainder of Section 4.11.

## 4.11.2. Electrostatic Discharge Protection

In the current design there have been several failures of the arm's electronic components, due to Electrostatic Discharge (ESD). This is a result of a technician or parent interacting with the electrical components, without proper methods of removing static electricity.

The present issue occurs more often due to non-technicians interacting with the electronics. To further prevent this, the housing will be sealed from the user. The housing should only be opened and worked on by a technician for hardware repairs. This alone will reduce the number of incidences due to ESD. When such repairs are being implemented the technician will work on the device on an ESD protective mat and utilize an Anti-Static Wrist Strap to ensure that any lingering static charge is grounded.

Conformal coating, which is mentioned in section 4.11.3, also offers some ESD protection on the device as the electronics will be coated and have no direct contact with the individual.

## 4.11.3. Conformal Coating

One of the goals for the T.U.B.A is to provide environmental protection for the electronic components. The 3D printed enclosure will provide protection from typical environmental stresses such as dirt and water exposure. While the aim of the project is to create an over-the-air maintenance interface for software updates, hardware maintenance is still a possibility in the future.

For such a case, the 3D printed enclosure would have to be open, thus exposing the electronic components of the design. Circuit cards that are exposed have the potential to cause harm to the functionality. To protect the circuit card, many companies will use a form of conformal coating to protect the board. Using a form of conformal coating will utilize a polymer film to protect against moisture or dirt.

For this project the PCB will be coated for environmental protection. There are several methods of PCB coating. Large companies typically send out their boards to be coated by a specialized conformal coating company. This is due to the large amount of boards that such company will produce. Since the scope of this project is to create a single board to serve as the new Limbitless Solutions prototype, such measure would not be cost-effective.

To remain cost effective, the group will purchase conformal coating from Amazon at the price of \$10.95, produced by MG Chemicals. This coating has been recommended by hobbyists for PCB coating. The coating will be applied by the team after the PCB has undergone testing and performs correctly.



As Limbitless Solutions is intending to create a large amount of this circuit board in the near future, it will be reasonable to have the boards sent out to be coated by a professional company to be coated as this would be cost-effective. In preparation of this, the team has provided a set of quoted costs for conformal coating, within the Section 9.2.1 of this document.

### 4.11.3.1. Heat Dissipation

There are varying types of conformal coating. A common feature of conformal coating is that they can be thermally conductive. The heat generated by the circuitry can be conducted through the coating and relieved from the device. Heat lying on electronic components is known to induce thermal stresses and increases the failure rate at which that component or components will experience a failure. In order to preserve and improve the lifespan of the circuit card the coating will feature thermally conductive material.

Many common electronic appliances, such as computers, generate heat on highly used components. High amounts of heat usually occur at the CPU level and to draw the heat from the processor, a heat sink can be used where the heat generated on the board will flow to a mechanical component, which holds the force of the heat until it dissipates naturally or through airflow. The current design does not feature any heat problems, but as the goal of this project is to utilize a 3D printed enclosure we can expect heat to be trapped inside of the enclosure.

PCB designs commonly use a protective layer of copper or aluminum alloy that effectively transfers heat away from the electronic components, acting as a heat sink. If the final design experiences an excessive amount of heat, an additional heat sink will be fixed to the design in addition to integrating a small level of airflow within the enclosure. If the on-board heat is minimal, the conformal coating along with the protective PCB layer, will provide satisfactory heat dissipation.

## 4.12. Integration with 3D Printed Enclosure

The current design for the electronics housing encases the servo, battery, and circuit board containing the rest of the electronics. This housing for the electronics is 3D printed to meet the footprint of the design. This current housing is susceptible to environmental stresses and due to this, several sets of electronics have malfunctioned and resulted in having the arm shipped back to Limbitless for repair. Figure 47 below shows the current electronic housing.

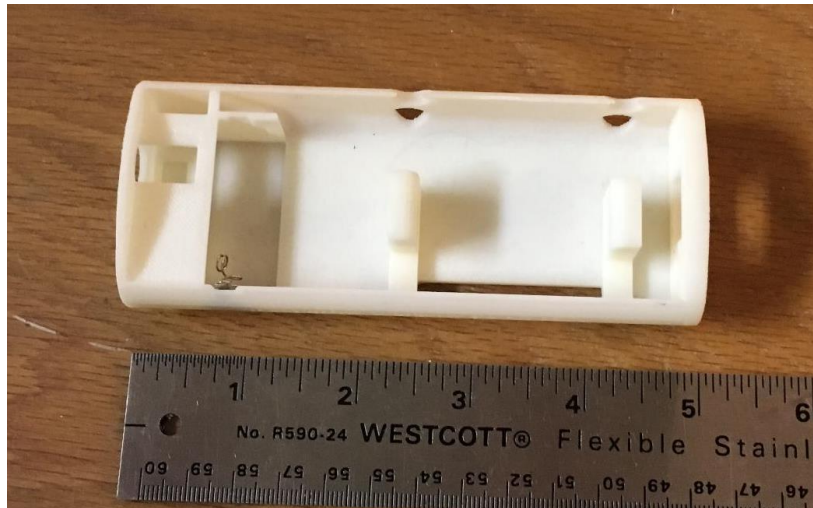

Figure 47: Current Electronics Housing

For this final design of the T.U.B.A the 3D printed housing must be redesigned to fit the constraints of the new set of electronics, while remaining resistant to environmental stresses. The layout of the new housing varies in comparison the previous design. This housing contains the servo motor and PCB. To shift the weight of the arm away from the forearm, the battery will be shifted into a sleeve containing the haptic motors. This will give the sensation that the weight of the arm has been reduced, while improving functionality. After fabrication of the PCB and acquisition of the remaining components, Limbitless Solutions will redesign the electronics housing to meet the new specifications. A functional block diagram is shown in Figure 48 to show the new housing layout.

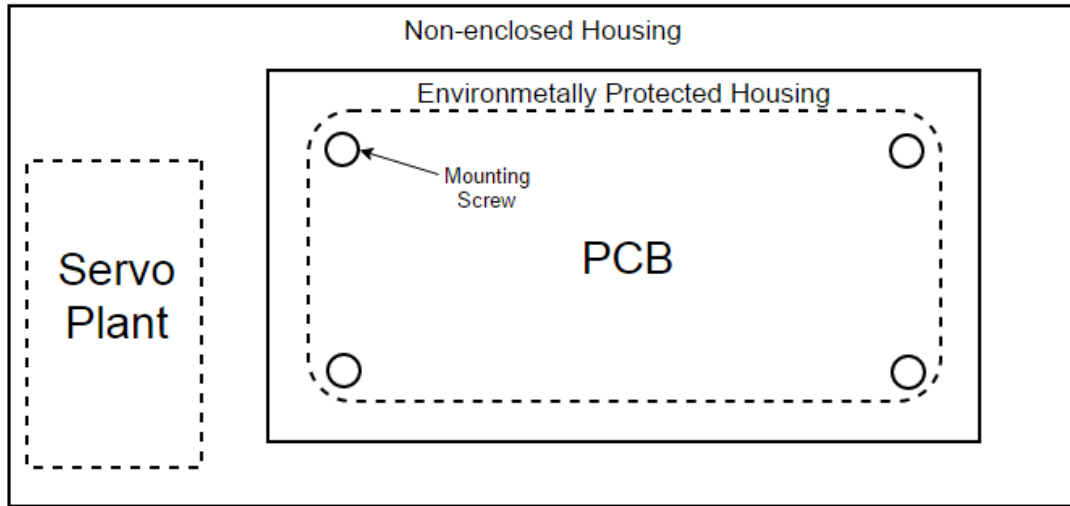

Figure 48: T.U.B.A Housing Diagram

### 4.13. Power Distribution

The general power distribution will flow from the battery into the DC/DC converter utilizing the 6.0 volt rail for the servo system, and the 3.3 volt rail for the rest of the system, the third rail will remain for future designs. For the T.U.B.A. the third rail will not be used.

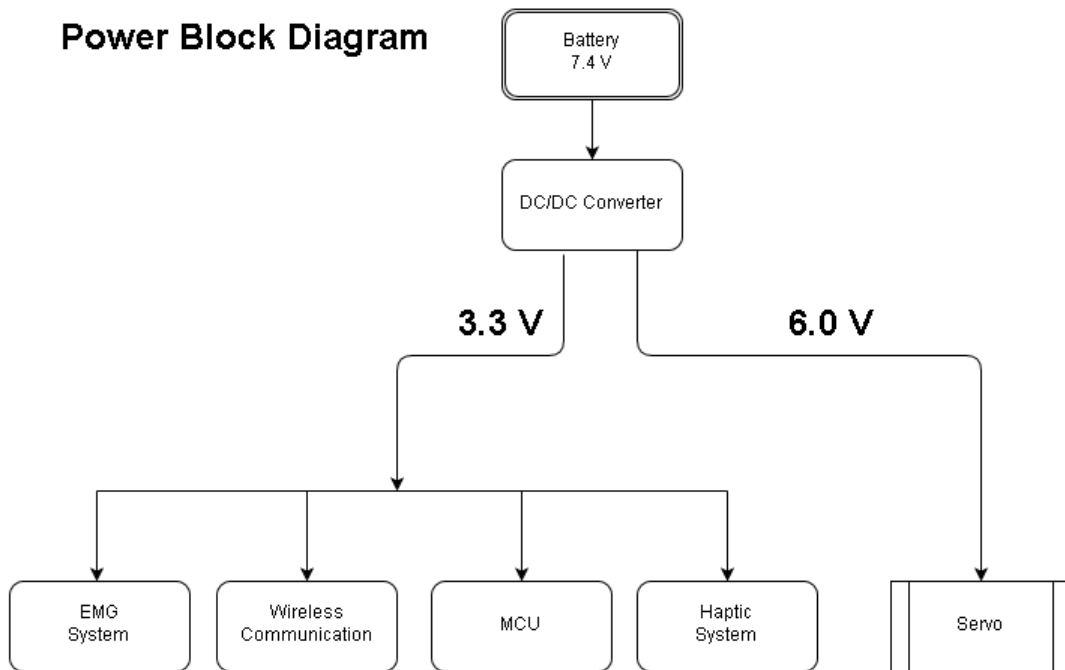

Figure 49: Power Block Diagram

### 4.13.1. Large signal (Motors/ Servos)

For the T.U.B.A. large signal refers to any device using greater than 3.3 volts for power. The integrated circuits all perform on the 3.3 volt rail, but the motor will function on a 6 volt rail.

### 4.13.2. Stepper Motors

Evaluations of the same points for the stepper motor as for the servo motor to continue along the decision process for what motor will best suit the T.U.B.A. project.

1. Torque requirements. The stepper motor does not have a dynamic torque range. The design for the T.U.B.A. as it stands does not require dynamic torque nor any kind of torque feedback for adjustable grip force. The torque that can be produced by a stepper motor can more than exceed the 0.85 Newton meters required to close the hand and hold small objects.
2. Speed. The ability to close the hand faster than the current design is one of our desired outcomes for the T.U.B.A. In most cases stepper motors are considered slow in comparison to servos, but that is from the point of view that anything rotating slower than 2000 rpm is considered slow. Most stepper motors will operate at the speed required to fulfill the closing time requirements for the T.U.B.A. design.
3. Stability. Defined as holding position fixed and firm while both in the off, zero power to motor, and fully on, max power holding the hand closed for maximum gripping force. Stepper motors function in the open loop configuration thus stay in place and while in the off position they draw zero current from the power source. This works in favor of the design constraints for the T.U.B.A. project.
4. Configuration. Stepper motors do not require any type of encoding to function. The stepper motor is linearly driven by the stators and knows its exact location in space, but they do require some kind of external microcontroller to handle this functionality. Stepper motors can be used with a motor controller and there are benefits for this type of configuration. Those benefits will be discussed later in the paper. Stepper motors also require far more wires and connection points, typically this is between six and eight connections.
5. Size. Both stepper motors and servos have similar properties with similar sizes depending on the manufacturer.
6. Cost. Stepper motors by and far appear to be the lower cost version of servos on the market.
7. Power. Stepper motors provide an additional benefit for power draw in the fact that they do not require power to hold constant torque, assuming the motor is used within its limitations. There is also no positioning error due to each position is physical due to the location of the stators and wire bundles within the motor. One of the design requirements for the T.U.B.A. is to extend the battery life.

Following the above identification points of stepper motors and servos it is clear that not only will a stepper motor be capable of serving the needs and meeting the

requirements for the T.U.B.A., but could bring several advantages to the project over the current design. Having said that, the power requirements are too great for T.U.B.A to supply. As such, a servo will still be used. The following list provides the advantages of a stepper motor if it were used.

- A. Lower power consumption
- B. Easier to program
- C. Better control for positioning
- D. Few components. Motor controller not mandated for operation.
- E. Provides sufficient torque for closing hand and lifting objects.
- F. Lower cost

Speaking with a representative from Texas Instruments, there is even the possibility of driving the stepper motor through a controller that reads the current draw for potential adjustment of torque applied at the grip. This could make future expansion of the T.U.B.A. easier and more desirable.

### 4.13.3. Stepper Motor Range of Motion

Most stepper motors have a range of motion between sixty and one hundred and twenty degrees. The current Limbitless hand requires a full one hundred and eighty degree to fully open and close the hand. Speaking with a few mechanical engineering students this is something that can be overcome with basic gearing that the Limbitless team should be able to easily design. This does come at a loss of torque so further investigation into this option is required.

## 4.13.4. Servos

There are many comparison charts, web pages, and other resources out on the World Wide Web discussing this very topic. Looking at the comparison for the T.U.B.A. requirements the following points are used for a final decision making process for what to use in the hand.

1. Torque requirements. Servos offer a dynamic range for torque to allow for adjustable load variances while active. This would allow for torque feedback to the haptic sensors. This feedback could be used to control how much torque the hand applies for the grip allowing for a for more complicated feedback system for touch. Under current constraints this might be desirable for the Veterans hands, but not for the child's hand.
2. Speed. Servos typically function at very high revolutions per minute (RPM) to drive motors such as wheels for remote control (RC) cars, or fan motors. In these areas much of the RPMs are wasted. These are typically larger than 2000 RPMs in use. This can produce a very fast rate of change for the closing of the hand, but in order to achieve such high RPMs a massive current is required in addition a drop in torque occurs. The T.U.B.A. is limited by the batter for current.
3. Stability. Defined as holding position fixed and firm while both in the off, zero power to motor, and fully on, max power holding the hand closed for maximum gripping force. Under this definitions sadly servos are found to be extremely lacking in this ability. Due to the closed loop feedback required to control the servo they are constantly adjusting position. This causes a twitching type action, as a result there is a constant drain on the battery even when the servo is supposed to be idle.
4. Configuration. Servos require encoding and must have some form of motor controller to handle this encoding. Many servos have built in controllers, but that will drive up the cost of the device. Having an external controller is desirable for servos.
5. Size. Both stepper motors and servos have similar properties with similar sizes depending on the manufacturer.
6. Cost. Dollar for dollar and performance for performance, servo motors run on the higher side of cost.
7. Power. Servos are always drawing some form of current even when idle. This will cause unnecessary strain on the battery. For the servo to hold either open, fully extended finger position, or closed a constant current must be sent to the motor. Once the current is removed the servo motors spin freely.

## 4.13.5. Small signal (ICs)

There are three basic ways to step the direct current voltage down from the 7.4 volts provided by the 2S battery pack: Voltage divider, voltage regulator, DC/DC converter.

### 4.13.5.1. Voltage Divider

The reasons for considering the voltage divider are its simplicity and ease to manufacture. When performed by hand with off the shelf, low tolerance resistors, there is a built in error between 2% and 20%. While the T.U.B.A. could handle such a wide range of error, this does tend to leave open many random potential issues down the road. Random power fluctuations are a leading cause of undesirable outputs by most modern electronic devices.

### 4.13.5.2. Voltage Regulator

Voltage regulators can be even simpler to implement than voltage dividers, but they provide a specified  $\pm 4\%$  for the LM2567 from Texas Instruments. This is the voltage regulator all computer and electrical engineering students at the University of Central Florida are exposed to in EEL 4309C Electronics II. This is a significant improvement over the classic hand built voltage divider.

### 4.13.5.3. DC/DC Converter

The most complicated from a schematic point of view is the DC/DC buck converter. This is typically a single chip, so for this project it is simply a black box implementation. Several options are available from Texas Instruments with a wide variety of input and output ranges. One example is the TPS65257. This device allows for an input range from 4.5V to 16V. One very important feature for this device is the adjustable output across three rails. These can range from 0.8v to as much as the input voltage providing a clean pass through for voltage if desired.

The output voltage from the TPS65257 is controlled by a simple resistive voltage divider shown in Figure 50 below. Texas Instruments recommends the use of a 1% tolerance or better divider resistors. For light loads starting with a value close to 40 k $\Omega$  for R<sub>1</sub> then use the following equation to calculate the value for R<sub>2</sub>.

$$R_2 = R_1 \frac{0.8 V}{V_0 - 0.8 V}$$

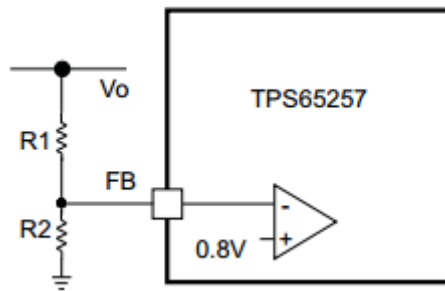

Figure 50: Voltage Divider Circuit



## 4.14. Charging

Limbitless Solutions has tasked the team with providing an improved charging system for the T.U.B.A. The current charging scheme is a modified cellular phone charging system via a mini-USB connection port. There is no voltage regulation past the charging of the battery into the rest of the electronics. This is one of the contributing factors to several of the current robotic arm design issues.

The T.U.B.A. design is tasked with improving upon the current design and if at all possible to incorporate wireless charging of some form.

### 4.14.1. Wireless Charging

There are several kinds of wireless charging available on the market today from solar, wind, tidal, microwave, laser, far-infrared, and so on. Wireless power supplies are sources of electricity that generate power from forms other than conventional means such as a batter or being plugged into a wall socket. There are several types of wireless power supplies such as solar, electromagnetic induction, wind power, solar power, tidal power, magnetic resonance, microwave power, laser power supply, and far-infrared to name a few. They all have a similar issue with being directly integrated into terminal equipment and require physical wires.

Solar has plenty of use in the state of Florida, but is not something that is very viable for objects that are not fixed, or that do not possess large flat surface areas to gather the photons. Solar is also very limited when not in direct powerful sunlight. For a robotic arm that is mobile, attached to a child, will be indoors during most of the sunlight hours, school, and does not have a large flat surface area, solar wireless charging is not considered for T.U.B.A.

Many of the other types of wireless power are great options for outdoor use like Wind, Tidal, Laser, far-infrared, and microwave. Not only are these for outdoor use both laser and microwave pose significant health issues to people and animals and as such are eliminated from consideration.

This leaves the team with magnetic resonance and electromagnetic induction. Both provide wireless power, neither pose significant health risks, both can be used on portable devices and indoors as well as outdoors.

Magnetic resonance, the absorption of electromagnetic radiation by electrons as a result of being exposed to specific magnetic fields. Others have performed research on the range and efficiency of this type of charging using high frequencies and large air gaps. In the megahertz range air gaps up to 200 mm can see on average 96% efficiency in power transfer. So if the source is 104.2 Watts, the receiver at 200 mm will be 100 Watts. This is very good efficient use of power. The ability to also transmit through wood and many other typical household furniture

building equipment is useful if a desire to keep the transmitter out of sight. These units are typically fairly large in size and at retail start around one thousand dollars. For the price alone that places this technology out of reach for the robotic arm. If price were not a concern this would be a power option due to the increased range and the ability to transmit through basic furniture materials.

Electromagnetic induction is caused by either a conductor moving through an electromagnetic field, or by having a conductor exposed to a changing electromagnetic field. For the use with the robotic arm this will be from the changing electromagnetic field generated by passing AC from a wall outlet into the transmitter circuit. The transmitting circuit consists of a primary winding coil that will generate the electromagnetic field. This field is received by the secondary winding inside of the device to be charged. One of the greatest advantages to this type of wireless charging is even with a short range, typically 77 mm, the electronics for the robotic arm can be separated from the environment aiding with the clients desire to both protect the electronics from dust and moisture, but more to the point to protect the circuitry from tampering. One of the largest issues expressed by the Limbitless organization is that many of the parents are not 100% satisfied with the functionality of the current arm design and think they know enough to tinker with the components and often times will short out the electronics by accident rendering the arm useless.

The cost of the transmitter, receiver pair from Texas Instruments is less than \$30 for the pair, this is a very affordable solution. Using the TI components also offers an extra advantage. TI has built their pair, transmit – receiver, to be able to transmit greater power. The following is copied directly from the TI data sheet web page for the BQ51025 wireless power receiver [TI].

Features BQ500215 Wireless Power Transmitter from Texas Instrument's:

1. Qi-Certified WPC v1.1 Solution for 5W Operations with Proprietary 10W charging capability with TI bq51025 Wireless Power Receiver.
  - a. Proprietary authentication protocol with TI bq51025 receiver
  - b. Faster charging time.
  - c. Compatible with standard 5W WPC receivers
2. 12V input, fixed frequency, rail voltage control architecture
3. Conforms to Wireless Power Consortium (WPC) A29 transmitter type specifications.
4. Enhanced foreign objection detection (FOD) implementation with FOD Ping that detects metal objects prior to power transfer.
5. Low standby power during idle and 'Charge complete'
6. 10 configurable LED modes indicate charging state and fault status.
7. Digital demodulation reduces components and simplifies circuitry.

*The bq51025 device is a fully-contained wireless power receiver capable of operating in the Wireless Power Consortium (WPC)*

*Qi protocol, which allows a wireless power system to deliver 5 W to the system with Qi inductive transmitters and up to 10 W when operating with the bq500215 primary-side controller.”*

This is a significant power increase over most standard Qi products on the market. The pairing of the BQ51025 receiver with the BQ500215 transmitter provides at least double the charging capability while in most cases performing this for less than double the price, giving our client the most bang for their buck.

The BQ51021 is the next closest device to pair with the BQ500215 for price, performance, range of operation, and are just over one half the price of the BQ51025 this would make a solid viable replacement even with the loss of 5W transfer to the batteries for charging as it has the same operating range, Pin/Packaging and 80% of the voltage output.

The BQ51003 is the least expensive receiver offered by Texas Instrument’s, but is also 25% less effective at transferring power to the batteries. For this reason alone the reduction in cost is not enough to make this a viable choice.

Both the BQ51013B and the BQ51221 come in less expensive than the BQ51025, but neither provide the 10W output power and both are only capable of delivering 5V of output to the batteries. Even with the BQ51013B being the second lowest cost device, there are far better elements in the project to cut costs than the pairing of the BQ500215 transmitter with the BQ5125 receiver. This data is summarized in table 16.

	<b>BQ51025</b>	<b>BQ51003</b>	<b>BQ51013B</b>	<b>BQ51021</b>	<b>BQ51221</b>
<b>Function</b>	Receiver	Receiver	Receiver	Receiver	Receiver
<b>Pout W</b>	10*	2.5	5	5	5
<b>Vin (max) V</b>	20	20	20	20	20
<b>Vrect (reg) V</b>	Dynamic	Dynamic	Dynamic	Dynamic	Dynamic
<b>Vout (regulated) V</b>	10	5	5	8	5
<b>Rating</b>	Catalog	Catalog	Catalog	Catalog	Catalog
<b>Operating Temp C</b>	-40 to 125	-40 to 85	Unavailabl e	-40 to 125	-40 to 85
<b>Pin/Package</b>	42DSBGA	28DSBGA	20VQFN 28DSBGA	42DSBGA	42DSBGA
<b>Approx. Price \$</b>	4.00/1ku	1.30/1ku	1.75/1ku	2.50/1ku	3.00/1ku

Table 16: Wireless Charging Interface Varieties

## 4.14.2. Carriage

The use of a carriage charger for either the entire T.U.B.A or a removable battery pack provides several advantages.

1. Ease of use.
2. Limited footprint.
3. Many designs to choose from that are currently on the market
4. Potentially an off the shelf item, thus reducing production cost.
5. Easy to replace if an off the shelf item is chosen.

These also provide a few disadvantages that our client would like to see removed from the equation:

1. Exposed metal
2. Off the shelf items are typically easy to penetrate by users
3. Not customizable to match the look and feel of the T.U.B.A.
4. Has the look and feel of something from the 1990's.

With parts 1 and 2 being the largest concerns for our client an off the shelf external charging station paired with a removable battery pack will not be used. This could be a potential option for speed of adaptation and ease of use for future arms.

## 4.14.3. USB Charging

The current charging design for the Limbitless hand is a USB phone charger that is limited to 3.3 volt at 100 mA, one charging unit, for the battery. As a result the battery can take several hours to charge. There is not a smart charger to limit the charging unit for an extremely low battery, nor is there an upscaling to hit the 500 mA for faster charging.

The Series B mini port, shown in Figure 51, is the current connection port in use. This connection type has five pins for power and data. Pin 1 is the +5 volt with pin 5 being ground. Some devices also require specific communication between themselves and the host (the charging device) before determining if the device and fast charge, or take advantage of the 500 mA. Some charges can provide greater than 3.3 volts by passing power down both the +5 and the -5 volt pins pushing to the current higher and supplying more than 3.3 volts to the battery or the system.

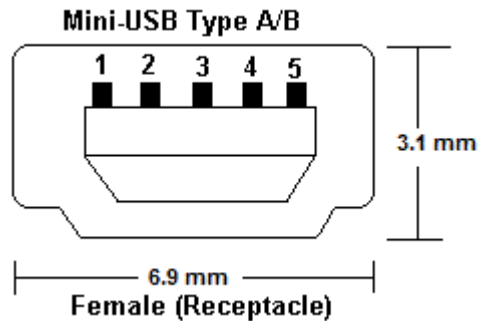

Figure 51: Mini-USB Connector<sup>&</sup>

There are several factors for USB chargers to be taken into account for the robotic arm. A simple charger that consists of the standard 5 volt input with one unit of charge without any kind of smart circuitry for load balancing, fast charging, exceedingly discharged battery charge is the simplest, but has a few concerns. One of the major concerns is safety based. Without any kind of overcharge circuitry the battery can enter into an unstable state potentially catching fire or worse exploding. Think back to the debacle that Dell faced between 2004 and 2006 forcing them to recall over 4 million batteries. These batteries were manufactured by Sony and were part of a batch of 22 million. Placing a potential fire hazard on a child's arm is far from desirable.

By adding a simple charge controller, limiting the current to 100 mA and pairing with an AC charge point capped at 350 mA a simple circuit can be used for a safer and simple charging that is currently used with the robotic arm.

For Figure 52 below, the 3.3 volt system load always pulls from the battery. This circuit will charge the battery when the AC power is connected. For systems that are active while charging with this simplified circuitry the battery will continue to discharge as long as the overall load exceeds the 100mA from the USB port alone. The robotic arm does not have that issue. The robotic arm is not designed to be tethered while in use. Therefore the current charging scheme while slow is effective and reduces the risk of overcharging the battery that can lead to injury.

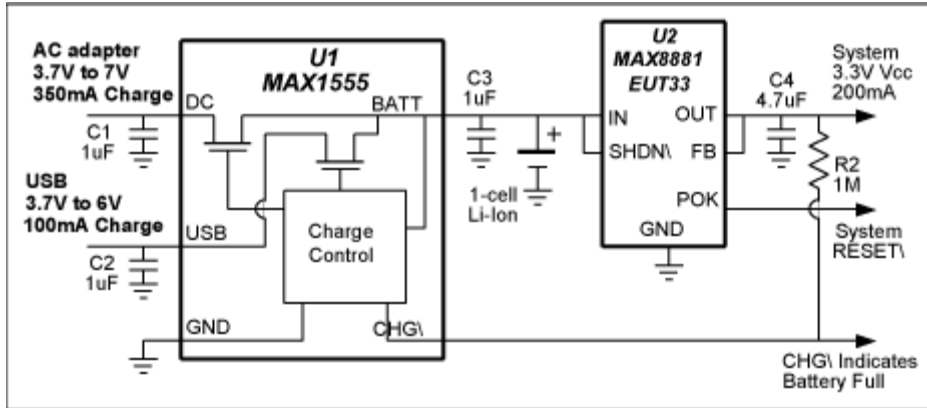

Figure 52: Charge Controller Schematic<sup>8</sup>

A more advanced set of options for modern charges includes load switching during connection and disconnect of the AC source, selectable charge current to match current capability of the source, be that USB or AC, over-voltage protection, and current limiters. The following circuit, in Figure 53 below, adds these features through the use of MOSFETs inside of the U1 charger IC.

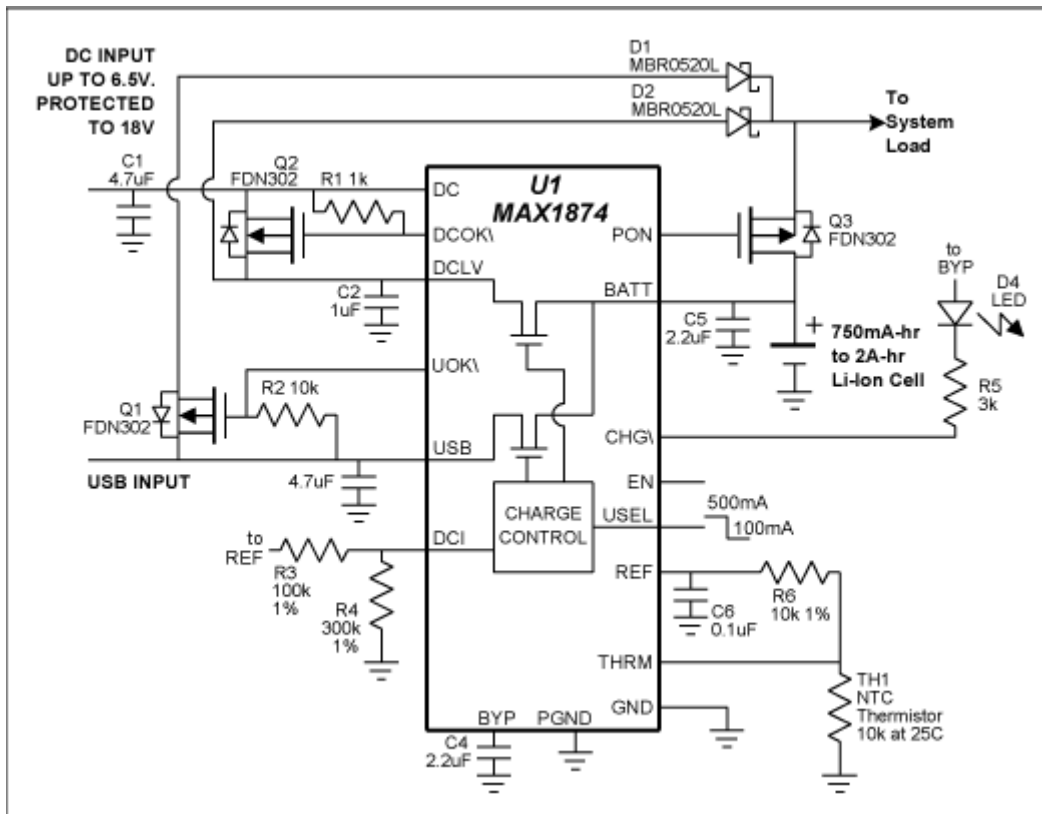

Figure 53: MOSFET Integrated Charge Controller Design<sup>8</sup>

This type of charging circuitry will allow for a device to charge while tethered as the Q1, D1 and Q2, D2, MOSFET and diode pair bypass the battery while either the AC or USB charging ports are connected. The robotic arm does not require

tethering, but can use several of the other features provided by this more complicated circuit. In addition to Q2, D2 cutting off power being drawn from the battery while connected, it also can provide up to 18 volt of over-voltage protection while allowing AC charging between 4 and 6.25 volts.

MOSFET Q3 reconnects the battery when there are no external charging sources for the load to pull from. This operation allows for no delay in switching from battery to AC and vis-à-vis.

USB devices once connected to a charger must identify themselves, this is called enumeration. This communication is what can allow for the increase from 100 mA to 500 mA being sent to the device. 100 mA is always the starting point, it is not until after enumeration that a negotiation can begin to determine if the 500 mA can be sent to the device. This can be an issue with some chargers as neither the 100 mA nor the 500 mA can be exceeded without causing potential damage to the device. If only a 10% accuracy is used on a 500 mA load, the max would have to be set no higher than 450 mA so as not to exceed 500 mA limitation on the USB device.

With these limitations and the specific requirement of the client a portable USB charging station, device, and cable are eliminated from consideration for this project. If the client was opened to the continued use of a USB cable or charging station for use, the second circuit would be a good upgrade for the robotic arm as it possess many advantages over the current design.

USB C connector will not be considered for this project, but they should be considered for future designs as they offer plenty of potential for fast charging, universal use and more. Currently they are very underdeveloped and several manufactures have been caught not following proper standards for manufacturing cables. Some of these cables have led to the damage of some devices and even destruction of other devices.

#### 4.14.4. Charging Schematic

The basic block diagram for the charging scheme consists of four basic elements shown in Figure 54 below. The BQ500125 wireless power transmitter, the BQ51025 wireless power receiver, the BQ24120 Li-Ion charging unit, and the 7.4 volt battery.

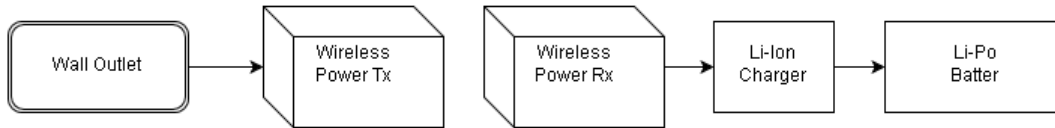

Figure 54: Functional Block Diagram of Charging Interface

The full schematics for the wireless charging transmitter and receiver are much too large to place in this document. As such, they can be found in the datasheets for the corresponding parts. The exact same designs that TI recommends will be used in T.U.B.A.



## 5. Standards

The following table outlines the major standards that apply to T.U.B.A.

<b>Standard</b>	<b>Governing Body</b>	<b>Parts Applied to</b>
Qi	Wireless Power Consortium	Wireless Charger
Bluetooth	Bluetooth Special Interest Group	MCU
C-11	International Organizations for Standardization (ISO)	MCU
IP rating	International Electrotechnical Commission (IEC)	Enclosure
SPI	N/A	MCU, ADS1293
I2C	N/A	MCU, DRV2605

Table 17: Standards

## 6. Prototyping Subsections

Given the sizable nature of the design needed for this project, each part needs to be examined and designed individually to increase the manageability of the overall effort. To accomplish this, the project will be broken down into subsections, which can be designed independently and then integrated into the project as a whole.

This section provides an outlined approach into how each module inside the project will be fabricated and validated once the research phase of the project has come to completion. Each subsystem will be tested using the facilities of the Senior Design Lab and Innovation Lab during the prototyping phase of the project.

### 6.1. Power

The power prototyping will be evaluated in several stages.

1. The BQ500215EVM-648 Wireless Transmitter Evaluation Board.
2. The BQ 51025EVM-649 Wireless Receiver Evaluation Board.
3. The BQ24120EVM-001 Li-Ion charging Evaluation Board.

The EVMs will be used to generate a generic prototype as detailed in the following sections. Once this is completed, the parts will be broken out into a dedicated PCB for final integration.

#### 6.1.1. BQ500215EVM-648 Wireless Transmitter

The BQ500215EVM-648 is Texas Instrument's evaluation board for their BQ500215 wireless power transmitter. This development board provides all of the functionality of a Qi-compliant wireless charging pad with a 12v input, single coil transmitter. The BQ500215EVM-648 supports both WPC v 1.1 and the older WPC v 1.0 standards for receivers. This means it can support output power up to 5W. When paired with the BQ51025EVM-649 receiver development board the output power delivered to the receiver is 10W instead of 5W.

The BQ500215EVM-648 evaluation board provides the team with the following features:

1. Proprietary 10 W charging capability with TI's BQ51025 receiver
2. Qi-certified WPC v 1.1 solution for 5 W operation
3. 12V input and fixed operating frequency
4. Enhanced foreign object detection (FOD) with FOD ping detecting objects prior to power transfer
5. Standard WPC A29-type transmitter coil with no magnet.

### 6.1.2. BQ51025EVM-649 Wireless Receiver

The BQ51025EVM-649 is Texas Instrument's evaluation board for the BQ51025 wireless power receiver unit. The BQ51025 integrated circuit is a secondary-side receiver device for wireless power transfer. This evaluation board is a fully contained wireless power receiver capable of functioning with any WPC v 1.1 protocol for up to 5W of delivered power. When paired with the BQ500215EVM-648 evaluation board this device is capable of receiving 10W of delivered power for portable applications.

The BQ51025EVM-649 evaluation board provides the team with the following features:

1. 10 W proprietary solution when used with the BQ500125 wireless transmitter.
2. Robust 5 W solution with 50% lower losses for improved thermals.
  - a. Adjustable output voltage (4.5 - 8.0 Volts).
  - b. 97% efficient post regulation.
  - c. 79% system efficiency at 5 W.
3. WPC v 1.1 compliant communication.
4. Patented transmitter pad detect function improves user experience.

### 6.1.3. BQ24120EVM-001 Li-Ion Battery Charger

The BQ24120EVM-001 is Texas Instruments evaluation board for the BQ24120 synchronous switch-mode 1-cell Li-Ion charger with 2 A FET, enhanced EMI performance. The evaluation board allows for fast evaluation of the charging management solution for the T.U.B.A. project. This evaluation board is capable of delivering up to 2 Amps of continuous output current. Texas Instruments programs the BQ24120 from their factory to deliver 1.33 Amps of charging current. With a power source, up to 16 V, and a Li-Ion battery the charging system can be evaluated.

The BQ24120EVM-001 evaluation board provides the team with the following features:

1. Input voltage range from 5 V to 16 V.
2. Charge rate: 1.33 A.
3. Output regulation voltage: 4.2 V
4. Number of series cells: 1\*

Speaking with Mr. German, the team's' consultant from Texas Instruments the BQ24120 is capable of handling the 2S batteries required by the BQ500215 transmitter and BQ 51025 receiver pair.

## 6.2. Charging

By combining BQ500215EVM-648 transmitter, the BQ51025EVM-649 receiver, and the BQ24120EVM-001 Li-Ion charger with a 2S 7.4 V battery a complete charging and base power supply can be evaluated and combined with the components for the entire project. The 2S 7.4 V battery will supply more voltage and current than the arm requires allowing for fluctuations from the power supply as well as providing a clean overhead. Ideally the required power with the total system draw would be paired to have no unused and thus expensive power left in the system. This typically would require a customized power solution for a project. This is currently beyond the scope of our client's desires and the T.U.B.A. project.

To prototype the system, a simple resistor network that will draw approximately the same current and place roughly the same resistive load to the power supply will be mocked up on a simple breadboard. This will allow for some rough calculations on the battery life expectancy for the client and the end user of the T.U.B.A.

## 6.3. Motor System

The prototyping of the motor system will involve the use of the pulse width modulation software developed by Limbitless Solutions prior to the creation of this project. Limbitless Solutions has been working with our client over the past year to year and a half. The servo is going to be off the shelf therefore is plug and play.

## 6.4. Microcontroller

The prototyping of the Microcontroller will begin with straightforward breadboard erection of the circuit, and the rest of the board will be built around this as the lynchpin of the circuit. Schmartboards have been ordered for the VQFN package that will allow the group to effectively use this complex package as a DIP, allowing easy breadboard prototyping either at home, or in the senior design lab.

The establishment of a working MCU to build off of is paramount, and this will more than likely take precedence over other areas of the circuit, until it is working properly. As is the case with most MCUs, a FET emulator may also need to be added to the board in line with a micro-USB port for initial programming as well as providing troubleshooting access to the circuit until it is ready to be enclosed inside the electronics housing. The team has stated that this micro-USB port may be made modular so that it can be removed from the circuit once initial programming is complete, as the same modular device could then be used for multiple builds, and only incur a one-time cost to the client. Prototyping pinouts will also be present on the preliminary PCB when designed and manufactured for troubleshooting purposes.

The DC/DC buck converter outlined in section 4.13.5.3 will also need to be built and tested prior to the prototyping of the MCU as well. The regulator should be relatively easy to prototype in the lab, but may need to undergo power analysis to make sure there is not excess heat being generated inside the case. If this is the case, higher efficiency regulation such as switching, may have to be reexamined as a potential solution.

Once these parameters have been established, coding may begin. The current code will have to be ported from the current Arduino IDE to the chosen, as the MCU is changing IDE's from the Arduino environment to Code Composer Studio. The plan will be to return the new prototype to its existing state with the new MCU before attempting to begin integration of the new modules.

## 6.5. Wireless Programming

The wireless programming module will be the final piece of the logical core to be implemented. It seems reasonable to have a fully functioning system prior to altering that system to be wirelessly accessed.

Another possibility for prototyping is utilization of the PAN-1325 evaluation module, which will be provided to the group by Texas Instruments. This approach will be utilized if the MSP430 if the MSP430 and CC2560 are utilized as laid out in the research sections. The layout of the module is as seen in Figure 56:

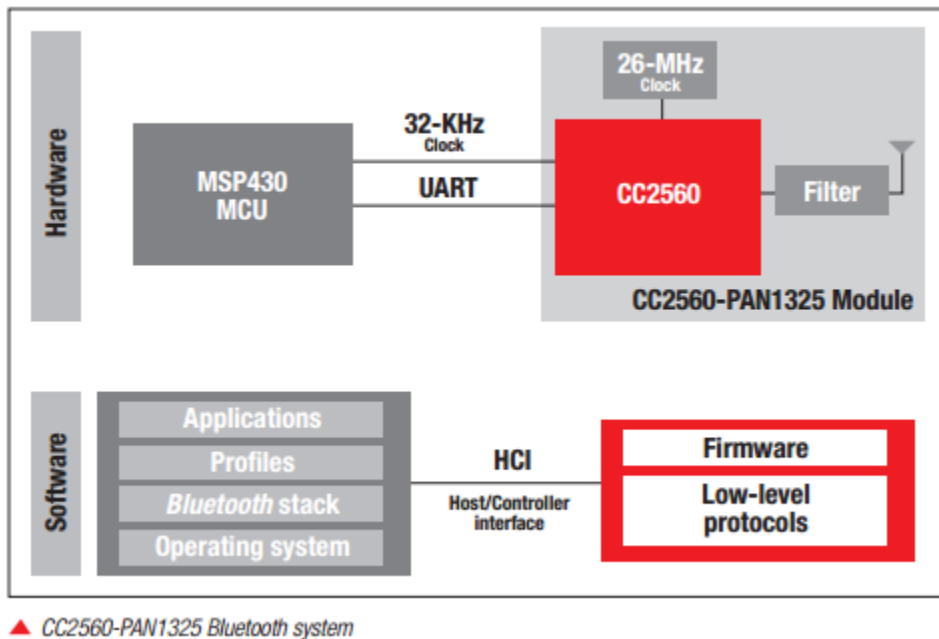

Figure 55: CC2560 EVM Block Diagram\*

The MSP430 present on this module is not the FRAM chip we will be utilizing in our final design, but the IDE the chip will work inside is, and therefore prototyping may be performed on this module, and the code ported to the FRAM MSP430 once it has been debugged completely.

For the first iteration of this process, the plan will be to hardwire the power management pin to the VCC pin, for a constantly on Bluetooth module. Once the board has been integrated to allow for wireless reprogramming, the needed logic and timing circuits will be added to allow the toggling effect of the chip to ensure maximum power.

In addition, Texas Instruments has pledged to provide a SimpleLink CC2650 evaluation module which may be used out of the box to begin coding an algorithm for the single chip solution.

## 6.6. Electromyography Sensor

The ADS1293 Evaluation Module will first be used. It will be programmed to perform simple Electromyography sensing. Once the correct settings and values to be loaded into registers are found to give the most reliable signal output, then the Evaluation Module will be connected to the main Microcontroller (rather than the onboard one on the module) to integrate the ADS1293 with the rest of the peripheral devices. At this stage the EVM will be thoroughly tested.

Once this testing is complete, the Evaluation module will have fully served its purpose. From here, the sensor will need to be integrated with the rest of the components fully. To do this, an initial revision of a Printed Circuit Board will need to be built. The testing will mainly consist of programming from there on out. The microcontroller code will be edited until all the subsystems fit together properly.

## 6.7. Haptic Sensor and feedback

The main goal in prototyping the sensor is to get a feel for the sensitivity. The haptic sensor in section 4.2.1 gives a table on the expected results of the sensor based on the amount of force applied. For the purposes of prototyping the haptic sensor, use of an Arduino board or MSP430 Launchpad can easily be used to measure output voltage or the amount of pressure on the resistor. Once a range of tolerances is determined for the pressure applied to the resistor, the values will be recorded and programmed into the microcontroller for the testing phase.

Using the current build of the arm, the sensor will be connected and the amount of pressure will be measured at different locations on the hand.

With the current build of the arm, the torque produced by the servo is severely limited and the group expects to dramatically improve its performance. This is due to the poor voltage regulation for the servo. With improved performance the pressure applied could increase and prototyping for the haptic sensor will have to be revisited during the testing phase in order to calibrate the expected pressure on the haptic sensor.

The rest of the haptic feedback system includes the motor and driver. Texas Instruments provides an evaluation board for the haptic driver, which is the DRV2605 EVM. This board includes the ERM and LRA motors soldered onto the board. The board also features capacitive buttons on the board which allows the user to configure the haptic effect selected and the different preprogrammed software routines. This allows for the customization to be done on a physical interface. This evaluation board includes all of the functionality that the haptic system will include, without the sensor. The board uses the MSP430, so the programming for the board will include very similar coding architecture for the microcontroller used for this project. The layout of the board is shown below.

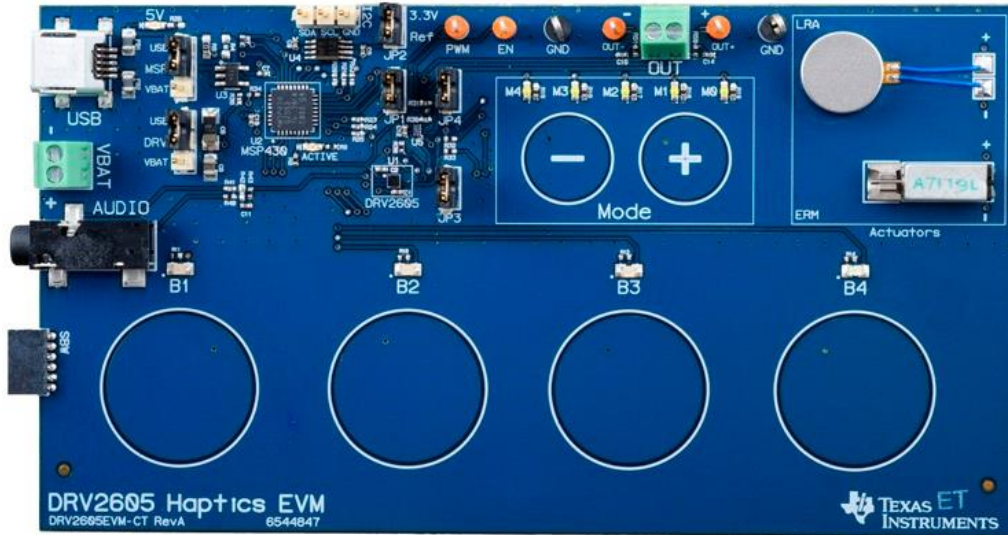

Figure 56: DRV 2605 EVM

Utilization of the board is detrimental for the team to successfully prototype the haptics that will be used in T.U.B.A. This will allow for the group to determine the best or several versions of customization to incorporate into the final product. An MSP430 Launch Pad can be connected to the device to control the board's software and make updates when using custom effects and routines. This feature can be utilized to verify the coding that will be featured in the final design. Once the code for these configurations is determined, it will be integrated with the software coding for the haptics sensor.

## 6.8. Environmental Protection

The environmental protection for the project includes resistance to shock, water, dirt, ESD, and heat. For these specifications shock resistance, heat dissipation and ESD will not be able to be prototyped during this phase of the project, as the electronic components will not be ready for implementation. For prototyping the environmental protection, the specifications for the size of the electronics and footprint of the PCB can be given to Limbitless Solutions where the necessary housing will be 3D printed. The printed housing can be then assessed for whether or not the enclosure can prevent the intrusion of environmental hazards, such as water and dirt. The enclosure will be sealed off for this testing and opened for evaluation of possible environmental intrusions.



## 7. Testing

This phase of the project shows the methodology used in testing the functionality of the T.U.B.A. Each set of components or function of the arm will be tested individually in order to verify that it is working properly. For the final part of the testing phase, the arm will be assembled to test it in its intended environment. At this point, the specifications of the prototype design will be compared to the requirements discussed in Section 2.4.

This section is designed to show compliance with the requirements and specifications set within section 2 of this document. If a component or function does not work properly, the design will be reevaluated and new parts will be ordered or a redesign of the circuit card will be necessary. Each subsection of section 7.1 will layout the method of testing each component or function of the arm. Once the design meets all specifications and requirements, the design will be complete and ready for production.

## 7.1. Test Plans and Flow

Each subsystem of this project builds upon itself for the final design. The design of the arm works as a building block. The subsections below show the flow of which subsystem must be first tested to the last tested. Haptic Feedback and Environmental protection of the arm are additional peripherals to further the design. Without the functionality of the EMG sensor, the microcontroller, and the power supply the design will not be functional. The flowchart shown in Figure 58 below, shows the necessary test plan for full integration of the project. The final design represents the fully integrated design.

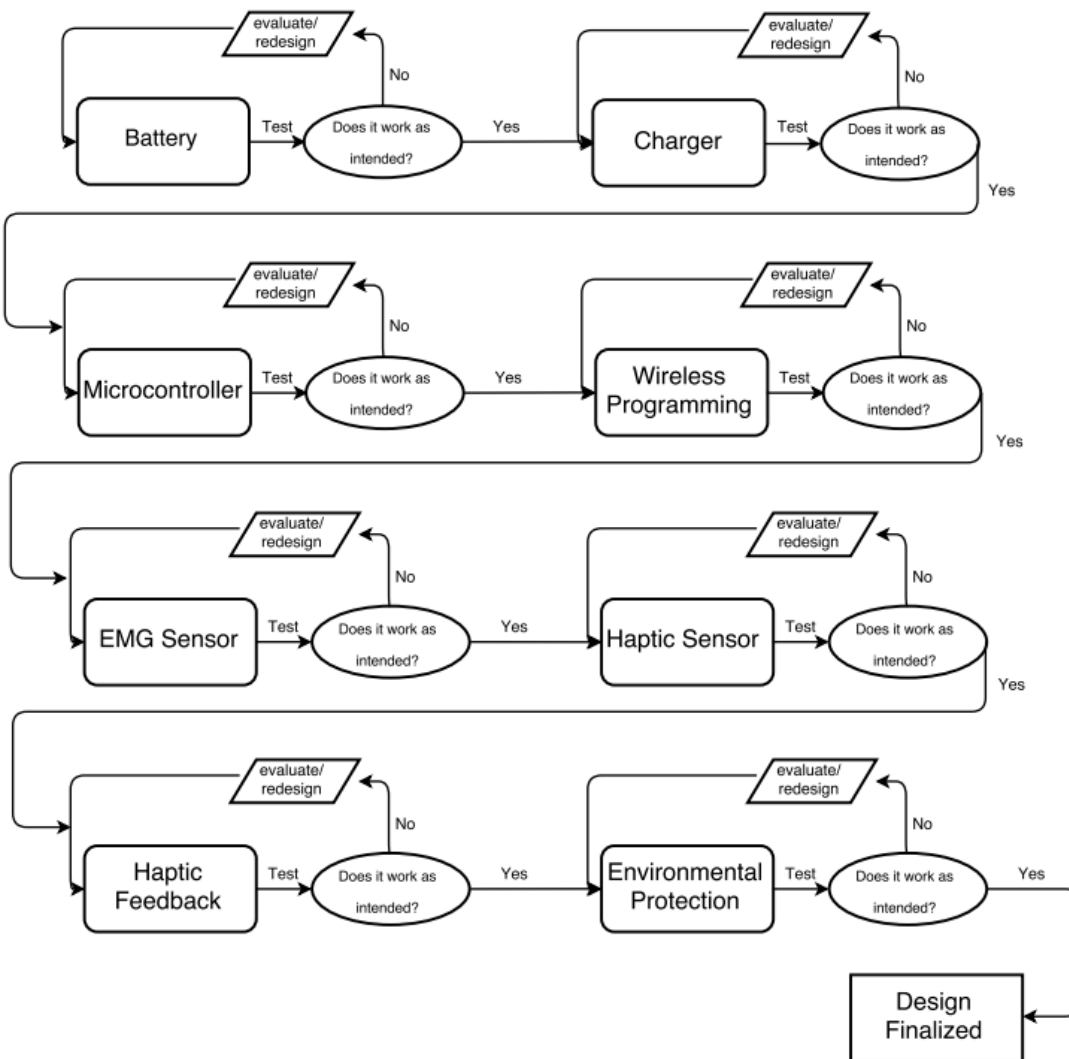

Figure 57: Test Plan Flowchart

## 7.1.1. Power

Evaluation of the power system for the T.U.B.A. will consist of at least three phases.

1. Prototyping through Thevenin's equivalent circuit view of the entire system.
2. Partial Thevenin's equivalent circuit view over individual circuits.
  - a. Electromyography sensors.
  - b. Haptic feedback sensor and driver.
  - c. MCU including wireless communications and programming.
3. Combined Thevenin's equivalent circuit view:
  - a. EMG, Haptic, Motor system

### 7.1.1.1. Phase 1

Prototyping through Thevenin's equivalent circuit will consist of no less than the following base circuit designs:

1. Maximum load:
  - a. Servo motor running full power non-stop.
  - b. Haptic sensors and drivers running non-stop.
  - c. Electromyography running non-stop.
  - d. Maximum power draw from the MCU's
  - e. Wireless enabled and receiving at highest baud rate.
  - f. Simulation of load from full system update/replacement of the OS on the MCU.
2. Minimum load:
  - a. Servo motor in standby mode.
  - b. Haptic sensors enabled but drivers disabled or in standby mode.
  - c. Electromyography in standby mode.
  - d. MCU in standby mode.
  - e. Wireless communication disabled.

The evaluation of the maximum load will place the power system under the greatest strain that should be possible by the T.U.B.A. configuration. Once the evaluation of the maximum load is concluded an increase of 50% to the load will be evaluated to provide for an overhead of protection. The power supply should be able to withstand a fault in the T.U.B.A. due to environmental, shock, or other unforeseeable damage to the electrical components. The evaluation of the load at 150% of the maximum if successful will provide a large safety margin for the client.

### 7.1.1.2. Phase 2

The partial Thevenin's equivalent circuits will provide specifics about each rail controlled by the DC/DC converter allowing for a more specific power calculations and evaluation of each subsystem. Once the Thevenin's equivalent circuits are evaluated the prototypes of each subsystem will be connected to the power system for further evaluation. The Thevenin's equivalent circuits will be:

1. Electromyography system Maximum load.
2. Electromyography system Minimum load
3. Haptic sensor and driver Maximum load.
4. Haptic sensor and driver Minimum load.
5. MCU Maximum load.
6. MCU Minimum load.
7. Servo motor system Maximum load.
8. Servo motor system Minimum load.

Upon completion of the above Thevenin's equivalent circuits the prototypes for each of the following will be evaluated:

1. Electromyography system.
2. Haptic system.
3. MCU including communications systems.
4. Servo motor system.

### 7.1.1.3. Phase 3

If there are issues in phase two, then an evaluation of the EMG sensor subsystem, the haptic subsystem, as well as the entire servo motor subsystem will be combined across multiple breadboards for further evaluation. This is for the elimination of potential power drain issues for the T.U.B.A. so the client will have an optimized product to build upon.

## 7.1.2. Charging

The testing of the charging system will consist of at least five phases.

1. Testing BQ500125 wireless transmitter.
2. Testing BQ510125 wireless receiver.
3. Testing BQ24120 Li-Ion charger.
4. Testing 1-8S LiPo battery voltage monitor.
5. Testing the 2S LiPo battery.

The use of the respective evaluation boards will be used for each test.

### 7.1.2.1. BQ500125 Wireless Transmitter

For the BQ500125 wireless transmitter the following will be evaluated:

1. External power source configuration.
2. Ensuring the foreign object detection is functioning properly to prevent harm to metal objects.

### 7.1.2.2. BQ510125 Wireless Receiver

For the BQ510125 wireless receiver the following will be evaluated:

1. Verify when paired with the BQ500125 wireless power transmitter then BQ51025 is receiving 10 W of power.
2. Confirm the variable output voltage range between 4.5 - 8.0 V

### 7.1.2.3. BQ24120 Li-Ion Charger

For the BQ24120 Li-Ion charger the following will be evaluated:

1. Verify that the 2S battery will charge with this device.
2. Verify the output current is 1.33 Amps.
3. Verify the output voltage is 4.2 Volts.

### 7.1.2.4. 1-8S LiPo Monitor

For the 1-8S LiPo monitor the following will be evaluated:

1. Displays proper voltage of the battery.
2. Sounds alarm when battery is low and in need of recharging.

### 7.1.2.5. 2S LiPo Battery

For the 2S LiPo battery the following will be evaluated:

1. Verify that when fully charged the battery delivers no less than 7.4 Volts.
2. Will charge without issue when paired with the BQ24120 Li-Ion Charger.

### 7.1.3. Microcontroller

Prior to coding for the project, a preliminary test program will be written that manually cycles through and toggles all GPIO pins on the microcontroller between high and low states. This will either be installed through a temporary micro-USB connection, or via a second microcontroller, such as a Texas Instruments Launchpad. Once the preliminary program is installed, and it is confirmed that all GPIOs are capable of realizing logic high and low, programming may begin for the base program, which will need to be in place and working prior to the integration of the wireless programming aspect of the project.

### 7.1.4. Wireless Programming

Once the prototype is developed and a stable connection can be maintained between the unit under test and a test computer, a typical looping program will be developed and used to ensure proper sampling rates and digital signal processing. This program will consist of several bit arrays of known orientation, such as a 16 bit shift register 0x0001 transmitted and shifted repetitively, to ensure that the bits being intercepted by the MCU is accurate. This will ensure that the timing structure of the OTA programming is correct, and that the instructions being sent are not corrupted, potentially causing damage to the hardware.

### 7.1.5. Electromyography Sensor

A special test program will be written to verify proper functionality of the Electromyography Sensor. This program will include a basic calibration routine at the start. It will then use LEDs to display when muscle flexes are registered (note, the hand actuation will not be used to allow the Electromyography sensor to be tested without the actuators being tested). The test program will allow buttons to be pressed to select which muscle sensor is being used. The tester will therefore have the ability to test the each individual muscle sensor/ muscle sensor channel and ensure that the calibration routines are working properly.

Use of this program will require proper electrodes to be placed on the user's arm. Since the electronics are not plugged into 120 Volts (like from an outlet) and the maximum voltage will be roughly 7-8 volts, there is no chance of the electronics shorting out and injuring the user.

## 7.1.6. Haptic Sensor and Feedback

The haptic feedback system will be tested to verify proper functionality. While tied to the microcontroller, the sensor and feedback mechanism will be tested individually through software. A separate programming routine will be developed to monitor the output from the force sensitive resistor. The FSR will be attached to the surface of the hand and will be closed on various objects to measure tolerance levels for sensing. The resistance as well as output voltage from the resistor will be monitored using a Multimeter device and recorded to formulate the ranges of pressure and their output.

A separate programming will also be developed for the haptic driver. The testing should result in the same response as the prototyping phase of the project. The microcontroller will be programmed to deliver a sequence of waveforms where a group member will attach a strap to secure the actuators to themselves to monitor the response. The timing of the response will be recorded to ensure that the response is effective and not delayed.

A similar procedure will be used when the sensor is integrated with the driver to provide the same response due to the sensor experiencing an applied force to trigger the enable signal for the driver. The output voltage will be monitored for the actuator to monitor efficiency. The response times for the start and stop of the actuator will be recorded to verify the effectiveness of the integrated response.

### 7.1.7. Environmental Protection

Testing of the environmental protection of the arm will require the necessary components to be fully assembled. Once assembled, the necessary tests to ensure that the board is operating fully will be carried out. All functionality must be verified before an environmental checkout. When ordering the PCB multiple units will be procured as three will be purchased and produced by OSH Park. One unit will be reserved for such testing. Before each environmental test, the board will receive a full evaluation on performance. Once the environmental stress has been applied, the board will be analyzed and evaluated to check if it is performing as expected. This form of testing is necessary in order to establish compliance with the specifications of the project. The corresponding test plan is demonstrated in Tables 18-20 below.

	Function				
	Haptic System	EMG Sensing	Servo	Charging	Wireless Programming
Pre-Test					
Post-Test					

Table 18: Shock Resistance Checkout

	Function				
	Haptic System	EMG Sensing	Servo	Charging	Wireless Programming
Pre-Test					
Post-Test					

Table 19: Dirt and Debris Checkout

	Function				
	Haptic System	EMG Sensing	Servo	Charging	Wireless Programming
Pre-Test					
Post-Test					

Table 20: Water Resistance Checkout



For this test plan, heat dissipation and ESD protection are not considered as these possible stresses are protected against through conformal coating and effectively dispersing heat. The methods in protection towards ESD do not offer complete protection, and because of this direct voltages or ESD will not be intentionally applied to the circuit card as this could potentially damage the electronic components.

## 7.2. Trace Results Back to Specifications

After the initial testing on all components of the design has been completed, the results of this testing will be analyzed. The features and characteristics of the T.U.B.A should be in accordance with the specifications and requirements of the project. The specifications of the arm will be quantified once the assembly is complete. The results of the testing will be recorded and shown against the requirements. If the results do not meet the expected results, the requirements of the design and the design itself will be evaluated, and the necessary changes will be made before the project is finalized and submitted to Limbitless Solutions.

### 7.2.1. Table of requirements

When evaluating each specification of the arm, Table 21 below will be used to verify compliance. If the measured outcome satisfies the requirement of the specified characteristic, the term "PASS" will be populated within the table to indicate that the requirement was met. These requirements were derived from Table 1, within Section 2.4 of this document.

Parameter	Requirement	Measured Specification	Compliance
Electronics Weight	Less than 0.45 kg for kids, 1.4 kg for Veterans		
Battery Life	10 Hours Standard Usage		
Price (wholesale)	Under \$350 for the overall design		
Environmental Protection	At least IP25		
Wireless Programmable Range	Minimum of 3 meters		
Charge Time From Entirely Drained Battery	Less than 8 Hours		

Table 21: Trace Back to Requirements

To test these specifications, the following procedures will be used:

1. Electronics Weight - Weigh the entire assembly of the electronics. Check against the 0.45 kg requirement.
2. Battery Life - Use a software routine that continuously uses the servo to close the hand. Measure the duration of time it takes for the battery voltage to become critically low. This will test how long the arm lasts in active use.
3. Price - After completion, the total the cost of the entire build will be calculated. The breakdown of this cost will be recorded in the Bill of Materials listed within Section 8.2.
4. Environmental Protection - The procedure for testing environmental protection is listed within Section 7.1.7.
5. Wireless Programmable Range - Test the programming range at different ranges. Determine the communication drop-off range.
6. Charge Time From Entirely Drained - After the battery checkout, time the duration of time it takes to charge fully from empty. Measure the output of the battery against the output at full charge.

### 7.3. Required Materials

While testing the components of the arm the team will require access to certain materials and equipment. There are various facilities that the group has at their disposal for the duration of the project. The fabrication and testing of the design will require access to the following equipment:

1. Oscilloscope, Tektronix DPO 4034
3. Function Generator, Tektronix AFG 3022B
4. Power Supply, Agilent E3630A
5. Breadboard
6. Multimeter, Tektronix DMM 4050
7. Soldering Iron and Solder
8. Pick and Place Machine and reflow oven
9. 3D Printer
10. Computer for programming MCU
11. Other Consumables not listed here

Having access to the Senior Design Lab, the Manufacturing Lab, and the Innovation Lab will provide the team with sufficient access to the required materials necessary for completion of the project. Limbitless Solutions owns a separate 3D printer within the Manufacturing lab that will be used to print out all the environmentally protected housing and the remaining non-electronic components of the arm.

## 8. Final Design

This section serves as a culmination of effort, resulting in a full set of design schematics for the overall system, as well as a complete itemized and costed bill of materials for building a single system. The resulting printed circuit board for the main circuit is also presented here, as well as a working assembly plan outlining the current execution phase for fabrication of the prototype.

### 8.1. Complete Schematic Footprint

This will be generated in Senior Design II using the individual schematics shown in the research section.

### 8.2. Parts Acquisition and Bill of Materials

The parts acquisition of the project depends on a variety of factors. Many tools and electronics will be received directly through Texas Instruments and procured at no cost for the design, as a result of sponsorship. Additional components not available through Texas Instruments, such as the haptic sensors and actuators, will be purchased through companies such as Adafruit and SparkFun. The servo motor and battery will be purchased from Amazon.com and RC Planet, respectively. The PCB will be ordered from OSHPark after completion.

Parts will be ordered in the order in which they are needed. The prototyping phase of the project uses evaluation boards for the microcontroller, EMG sensor, charging interface and haptic feedback system. These items were procured from Texas Instruments to begin prototyping the designs, free of charge. Parts such as the battery and EMG sensor must be acquired and tested initially to verify functionality as they do not have their own evaluation boards.

A complete Bill of Materials describing the build of the project is shown in Table 22 below. The Bill of Materials does not include solder or equipment costs as this will be provided by the University.

Component	Source	Part Name / Number	Quantity	Cost
Battery	RC Planet	VNR15083	1	\$45.87
Induction Transmitter	Texas Instruments	BQ500215RGCT	1	\$10.35*
Induction Coil Transmitter	Wurth Elektronik	760308141	1	\$21.00
Induction Receiver	Texas Instruments	BQ51025YFPT	1	\$10.35*
Induction Coil Receiver	Mouser	IWAS4832FEEB150J50	1	\$5.30*

<b>Component</b>	<b>Source</b>	<b>Part Name / Number</b>	<b>Quantity</b>	<b>Cost</b>
Li-Ion Charger	Texas Instruments	BQ24120RHLT	1	\$5.18*
Overvoltage Protection	Texas Instruments	BQ771605DPJR	1	\$1.43*
LiPo Battery Monitor	Tossen Robotics	VOLT-TESTER	1	\$12.95
DC/DC Converter	Texas Instruments	TSP65250RHAT	1	\$5.45*
P.C.B	OSHPark	N/A	1	\$10.00
Shrink Wrap	Skycraft	N/A	2 ft.	\$5.00
LRA Device	Precision Microdrives	C10-100	1	\$10.15
Force Sensitive Resistor	Sparkfun	09673 ROHS	1	\$5.95
Haptic Driver	Texas Instruments	DRV2605YZFR	1	\$4.00*
Microcontroller	Texas Instruments	CC2650	1	\$6.93*
Servo	Tower Pro-Fulfilled by Amazon	MG995	1	\$6.99
EMG Sensor	Texas Instruments	ADS1293	1	\$11.55*
EMG Electrodes	The Electrode Store	DDB-30BSAF: Reusable Bar Electrodes	1	\$25.00
Conformal Coating	Amazon	779008419359	1	\$10.95
Total Cost			1	\$224.40
Total Cost Without Donated Components			1	\$163.86

Table 22: Bill of Materials

Note: \* Indicates that the parts will be donated either from Texas Instruments or other sources that Limbitless has partnerships with.

### 8.3. PCB Design

The Printed Circuit Board will be designed in EAGLE for both the Schematics and the actual board design.

Once all schematics are finalized, they will be integrated and connected in schematic view in EAGLE. From here, the parts will be placed and routed in the board editor. This is where the size will be optimized.

The PCB will then be approved by Limbitless Solutions prior to fabrication. This will allow Limbitless Solutions to have the final say in PCB size, shape, and complexity before it is built. It will also give them a chance to add any special silkscreen designs they would like.

### 8.4. PCB Fabrication

The PCBs will be ordered from OSH Park. They have competitive prices, easy-to-use tools, and excellent quality. They are also a favorite of many open-source hobbyists which will allow the design to be easily shared with others.

Once the PCBs and components have been received, the board will be assembled. Limbitless Solutions owns a Pick-and-Place machine that will be utilized to build the boards. From there, the reflow oven in the Texas Instruments Innovation Lab, or the oven owned by the Amateur Radio Club at UCF, will be used to finalize the soldering of the boards.

## 8.5. Assembly Plan

Once the fabrication of the PCB is complete and in the hands of the group, the final design will begin assembly. Certain subsystems will be assembled independently such as the charger and battery, which will be soldered and connected using tools in the senior design lab or innovation lab. This can be completed before acquisition of the board. After acquisition of the PCB the components can be surface mounted to the board and pin connections can be soldered in place. Wires and connections to the haptic sensor and actuator will be extended from the board to reach the length from the housing the hand and mounting strap respectively.

After all components and functions are tested, using the methods specified in Section 7 of this document, the PCB will be coated and methods for effective environmental protection and heat dissipation will be applied. All electronic components at this point will be contained within the 3D printed housing, creating a “black-box”. The housing will then be integrated with the arms structure, and wires for finger actuation will be connected to the motor. The haptic sensor will be mounted to the surface of the hand.

The battery will be fitted into a sports sleeve like device that runners use for holding MP3 players or cellular phones. This will work for cases where the individual still has the upper arm or at least a large portion of their upper arm. For clients without a large enough upper arm section, a chest mounted device can be implemented. In order to receive effective haptic feedback, the LRA will be placed within this device as well.

The assembly of the charging unit pairs with the battery containment unit. There are two physical containment devices. The first is the wireless power transmitter base unit. Limbitless Solutions can customize the exterior to match the look and feel of the robotic arm aesthetics. This housing will contain the wireless power transmitter as well as the wired connection to the wall outlet.

The battery containment unit will house the battery, the wireless power receiver, the Li-Ion battery charger, and the Li-Ion overvoltage protection chip. There will be a port to allow for the power cable to connect to the robotic arm supplying power for the rest of the circuitry and for the servo motor.

## 9. Administrative

This section covers administrative areas of the project. A major desire and goal of the authors is to not simply build a prototype, but also to establish a full fabrication solution for Limbitless. This section serves to cover the administrative aspects of that solution, including budget for the project, milestone logistics, and individual and corporate sponsorships found during the course of research. Most importantly, a full commercial build and cost plan is outlined for mass production, as well as potential savings through effective minimum buys and specific vendors.

### 9.1. Milestone Chart

In order to meet the goals and objectives of this project, a milestone timeline for the course of Senior Design I through Senior Design II, was created and is provided in Figure 59 below. The milestone timeline illustrates the effective steps that the team would take to complete the project. This outlines the specific time periods used to research, design, prototype, and test the project. The group determined that it would take approximately one month to evaluate and research each of their fields to get an understanding of the concepts behind design each function. After this period, each member would spend the remainder of Senior Design I to design each component of the build. During this time, each member would attempt to integrate their design with the entire project.

After the completion of Senior Design I, the group will spend the remainder of Senior Design II prototyping the design, testing out its overall performance once fabricated, then performing optimizations to the design and retesting before the final product is finished.

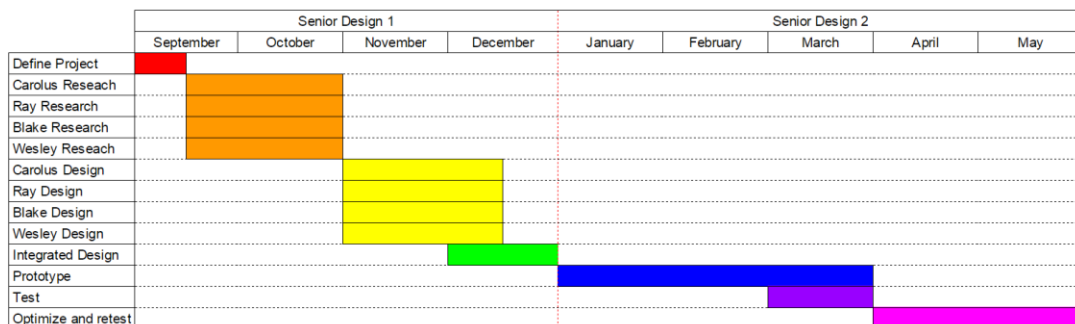

Figure 58: Milestone Chart

## 9.2. Budget

Limbitless solutions has set a target of \$350.00 for their desired costs in the footprint for future builds. However, it must be understood that there will be significant “one-time” prototyping costs involved with this project. That being said, the team has estimated the costs depicted in Table 23 to be a rough estimated budget for the execution of this program.

- The prototyping section included all the EVMs that TI donated as well as additional materials for power and assembly.
- Testing includes the cost of building a full set of T.U.B.A. as well as any external components required to test.
- Final Build is the cost of producing a final, polished product.
- Emergency fund is a margin built in to the budget in case something needs to be replaced or added.

Item	Cost
Prototyping	\$150.00
Testing	\$400.00
Final Build	\$250.00
Emergency fund	\$200.00
<b>Total Cost</b>	<b>\$1,000.00</b>

Table 23: Estimated Budget

### 9.2.1. Commercial Build and Cost Plan

The budget of the T.U.B.A is comprised of a single prototype design. This design will be verified and tested throughout this project to ensure that it performs as expected. After the final build, the group will provide Limbitless with the Bill of Materials to show the entire cost of producing the arm. Table 24 shows the list of the components used in this design and the cost of producing them at higher quantities to reflect what the cost would be for mass production in the future. All costs below represent the cost per Item if at least 100 of each part is bought.

Component	Source	Part Name / Number	Quantity	Cost
Battery	RC Planet	VNR15083	1	\$45.87
Induction Transmitter	Texas Instruments	BQ500215RGCT	1	\$7.82*
Induction Coil Transmitter	Wurth Elektronik	760308141	1	\$17.95
Induction Receiver	Texas Instruments	BQ51025YFPT	1	\$7.82*



Component	Source	Part Name / Number	Quantity	Cost
Induction Coil Receiver	Mouser	IWAS4832FEEB150J50	1	\$3.51*
Li-Ion Charger	Texas Instruments	BQ24120RHLT	1	\$3.91*
Overvoltage Protection	Texas Instruments	BQ771605DPJR	1	\$1.05*
LiPo Battery Monitor	Tossen Robotics	VOLT-TESTER	1	\$12.95
DC/DC Converter	Texas Instruments	TSP65250RHAT	1	\$4.11*
P.C.B	OSHPark	N/A	1	\$8.00
Shrink Wrap	Skycraft	N/A	2 ft.	\$2.50
LRA Device	Precision Microdrives	C10-100	1	\$8.19
Force Sensitive Resistor	Sparkfun	09673 ROHS	1	\$5.36
Haptic Driver	Texas Instruments	DRV2605YZFR	1	\$2.96*
Microcontroller	Texas Instruments	CC2650	1	\$5.21*
Servo	Tower Pro-Fulfilled by Amazon	MG995	1	\$6.99
EMG Sensor	Texas Instruments	ADS1293	1	\$5.50*
EMG Electrodes	The Electrode Store	DDB-30BSAF: Reusable Bar Electrodes	1	\$25.00
Conformal Coating	Amazon	779008419359	1	\$10.95
Total Cost			1	\$185.65
Total Cost Without Donated Components			1	\$143.76

Table 24: Commercial Build and Cost Plan

Note: any price fields marked with an \* indicate that the parts will be obtained free of charge either from Texas Instruments or other sources that Limbitless has partnerships with.

### 9.3. Consultants, Subcontractors, and Suppliers

As denoted by the Commercial Build Plan, the team will be acquiring parts from Texas Instruments, Precision Microdrives, Sparkfun, Würth Elektronik, Digikey, Mouser, RC Planet, Tossen Robotics, Tower Pro, Amazon.com, and The Electrode Store. The PCB will be serviced and printed by OSH Park. The mechanical side of creating the housing for the electronics will be performed by Limbitless Solutions, who will then integrate the housing with the team's design upon completion. Being under the University Program with Texas Instruments, the team has several contacts at the company. These contacts have been in touch with the team throughout the course of the project, and recommended parts based on the requirements of the design and provided evaluation boards for prototyping when needed.

### 9.4. Sponsorship

Limbitless Solutions has promised to provide our team an initial budget of \$1,000 for the project. This amount will cover the cost of materials for prototyping and the final build of the bionic arm. The budget described in section 9.2 above, is set for the final cost of arm as the aim is to feature a low-cost final product that will be produced many times over. The initial budget was set for this rate to design and prototype varying methods of charging, motors, and haptic actuators.

Before tasking the project to the team, Limbitless had been in contact with Texas Instruments, who has been very interested with the project. Over the course of Senior Design I, Texas Instruments has formed several contacts and connections with the group, putting this project under the scope of the University Program at the company. As a result, Texas Instruments will be providing our team components, development boards, and support as a donation for this project. The cost of these boards or components will not be factored into the initial budget for the project, but will be factored into the overall cost if the part will be featured in the final product.

As part of the final design, a final budget will be drafted with a list of applicable vendors for the overall build, so that Limbitless Solutions can produce the arm at the final cost. Included with this the sponsor will have access to the PCB design and a list of discounted costs of purchasing components for multiple units.

In addition to this, our team will be pursuing donations from companies as much as possible. Limbitless Solutions has indicated that due to the nature of their work, companies tend to be willing to donate parts and grants.

Any additional funding towards this project will be used in Limbitless Solutions' effort towards creating arms with this design implemented in the future.

## 10. Conclusion

The research executed and contained in this paper has laid the framework for the authors to develop a full working solution for Limbitless Solutions, including schematics, materials, and a plan of action on how to execute, test, and integrate the prototype to come. In addition to the electronics choices made, a full analytical process is now presented to Limbitless for their future research, providing them with insight on the parts explored by this team as to their strengths and weaknesses for the given areas of implementation.

With a completed design in hand, a full working schematic may be captured and integrated with ease through the compilation of the individual drawings above, leading to a preliminary PCB being constructed and ordered prior to the conclusion of Senior Design 1. With successful testing, Gerber files will be created and maintained, alongside a fully published bill of materials, allowing Limbitless to maintain their inventory for the electronics package down to the consumables level.

However, the work discussed in this paper is only in its infantile stage, and another challenging semester still lies ahead, beginning with the construction of a stable electronic system in the laboratory, and culminating with working hand in hand alongside Limbitless Solutions' mechanical team to fabricate and integrate the electronic package into a full working prototype. While the responsibilities of this project are to only achieve a working electronic design, the hope and goal of this team is to leave a legacy at this University in the "hand" of yet another hopeful Limbitless client.



## Appendix A - Acronyms

<b>Abbreviation</b>	<b>Meaning</b>
AC	Alternating Current
ADC	Analog to Digital Converter
AFE	Analog Front End
BT	Bluetooth
CCS	Code Composer Studio
CMRR	Common Mode Rejection Ratio
DC	Direct Current
DIP	Dual In-line
ECE	Electrical and Computer Engineering
EE	Electrical Engineering
EEG	Electroencephalogram
EKG or ECG	Electrocardiogram
EMG	Electromyography
ERM	Eccentric Rotating Mass
ESD	Electro-Static Discharge
FOD	Foreign Object Debris
FSR	Force Sensing Resistor
GPIO	General Purpose Input Output
HCI	Human Computer Interface
I2C	Inter-Integrated Circuit
IDE	Integrated Development Environment
LDO	Low Dropout
LED	Light Emitting Diode
LRA	Linear Resonant Actuator
LS	Limitless Solutions
MCU	Microcontroller
NFC	Near Field Communication
OTA	Over the Air Programming
PCB	Printed Circuit Board
PWM	Pulse Width Modulation
Rx	Receive
SPST	Single Pole Single Throw
TI	Texas Instruments
Tx	Transmit
UART	Universal Asynchronous Receive and Transmit
UCF	University of Central Florida
UWB	Ultra-Wideband
VQFN	Very Thin Quad Non-leaded Package

Table 25: Acronyms

## Appendix B - Permissions

**Adafruit Industries** <support@adafruit.com>  
To: Blake Steiner <blakes9308@gmail.com>

Totally OK!

On Mon, Nov 30, 2015 at 5:00 PM, Blake Steiner <support@adafruit.com> wrote:

security token :  
contactname : Blake Steiner  
email address : [blakes9308@gmail.com](mailto:blakes9308@gmail.com)  
contact us 2 section : press  
useragent string : Mozilla/5.0 (Windows NT 6.3; WOW64) AppleWebKit/537.36 (KHTML, like Gecko) Chrome/46.0.2490.86 Safari/537.36  
message text : Hello I am an Electrical Engineering student at the University of Central Florida, developing a senior design project. I am working on creating a haptic feedback system for Limbitless Solutions a non-profit company dedicated to producing bionic limbs for children in need.

I am requesting to using the force sensitive resistor diagram and table captured within the following document:

<https://learn.adafruit.com/downloads/pdf/force-sensitive-resistor-fsr.pdf>

Thank you for you time!  
Client IP: 75.112.177.134



E

---

### Flex22 Sensor

2 messages

---

**Blake Steiner** <blakes9308@gmail.com>  
To: sales@spectrasymbol.com

Hello, I am an electrical engineering student at the University of Central Florida. I am working on the documentation for a senior design project that is a bionic arm with integrated haptics.

I would like to request permission to use diagrams from your datasheet featured on sparkfun's website:

<https://www.sparkfun.com/datasheets/Sensors/Flex/flex22.pdf>

The images are shown to represent the potential role that the Flex22 sensor could have in being used as a haptics sensor. All images will be referenced as Spectra Symbols images.

Thank you for your time.

---

**Shannon Mills** <sales@spectrasymbol.com>  
To: Blake Steiner <blakes9308@gmail.com>

Blake,

That is fine. Thank you for asking.

Shannon Mills

Sales Engineer and Business Development

Spectra Symbol Corp [www.spectrasymbol.com](http://www.spectrasymbol.com)

Tel: 801-972-6995 ext. 20 | Fax: 801-972-8012

[SMills@spectrasymbol.com](mailto:SMills@spectrasymbol.com)

3101 West 2100 South Salt Lake City, UT 84119



Blake Steiner <blakes9308@gmail.com>

---

## Request Permissions for LRA and ERM actuator diagrams

4 messages

---

Blake Steiner <blakes9308@gmail.com>  
To: enquiries@precisionmicrodrives.com

Mon, Nov 30, 2015 at 5:48 PM

Hello I am an Electrical Engineering student at the University of Central Florida, developing a senior design project. I am working on creating a haptic feedback system for Limbitless Solutions a non-profit company dedicated to producing bionic limbs for children in need.

I am requesting to use the figures for ERM and LRA devices on the following webpage to show the characteristics of each type of motor. The LRA will be purchased from your website and included in the project.

<http://www.precisionmicrodrives.com/haptics-haptic-feedback-vibration-alerting/haptic-feedback-in-detail/adding-and-improving-haptic-feedback>

Thank you!

12/2/2015

Gmail - Request Permissions for LRA and ERM actuator diagrams

Reply-To: Precision Microdrives <enquiries@precisionmicrodrives.com>  
To: Blake Steiner <blakes9308@gmail.com>

=== Please reply ONLY ABOVE THIS LINE when responding ===

**From:** Ryan Hulbert

Hi Blake,

Thank you for your email.

This will be fine, we would appreciate it if you can reference our website directly, especially if your research will be published anywhere on the internet.

Please do let us know if there is anything we can do for you in the future.

Best regards,

Ryan Hulbert  
Sales Engineer

-----

TEL: +44 (0) 1932 252 482

WEB: [www.precisionmicrodrives.com](http://www.precisionmicrodrives.com)

Precision Microdrives - Leading suppliers of miniature DC motors, gear motors & vibration motors.

Registered in England and Wales No. 5114621. Unit 1.05, Canterbury Court, 1 Brixton Road, London, SW9 6DE, United Kingdom

-----

Sign-up to our [super useful monthly technical email here](#), or read our [technical blog](#) which contains details of latest technical developments, and guidance for applications.

**Please note our [critical component and life support policy](#).** This is on the final page of every datasheet and in our terms and conditions of sale. A critical component is one which could cause damage to property, or harm to living beings, if it were to fail. You must disclose to us if you are using, or intending to use one of our parts as a critical component in an application. This is so that we can run a risk assessment, and provide you with parts that are most suitable for the application.

---

**wesley.mullins**

---

**From:** brian.e.kaminski@gmail.com on behalf of Brian Kaminski <brian@advancer.co>  
**Sent:** Monday, November 30, 2015 11:11 AM  
**To:** wesley.mullins  
**Cc:** facebook@advancer.co; Albert Manero  
**Subject:** Re: Limbitless Solutions Senior Design

Hi Wesley,

Feel free to use any of our online materials.

Cheers,  
Brian

On Sun, Nov 29, 2015 at 6:43 PM, wesley.mullins <[wesley.mullins@knights.ucf.edu](mailto:wesley.mullins@knights.ucf.edu)> wrote:

Hello,

I am currently a student of Electrical Engineering at the University of Central Florida. I am currently in Senior Design and my team is working with Limbitless Solutions to improve their electronics in the arms.

My team is writing our final report before we start prototyping our design. We were planning on using some of the information and diagrams from the documentation that is available for your Muscle Sensor V3 and possibly the new MyoWare sensor.

Is this okay with you? We will properly cite/ credit the images back to Advancer Technologies.

Many thanks,

Wesley Mullins

--  
Cheers,  
Brian



12/4/2015

RE: Permission to use images - Raymond Brunkow

## RE: Permission to use images

German, Trey <treygerman@ti.com>

Thu 11/12/2015 10:01 AM

To: Raymond Brunkow <rbrunkow@knights.ucf.edu>;

Hey Ray,

Go for it! J

Trey

---

**From:** Raymond Brunkow [mailto:rbrunkow@knights.ucf.edu]

**Sent:** Wednesday, November 11, 2015 5:04 PM

**To:** German, Trey

**Subject:** Permission to use images

Trey, this is Ray Brunkow, I am working with Wes Mullins on the Limbitless project. I am asking for written, e-mail, permission to use some of the images and schematics from TI's documentation for our paper.

Thank you in advance

Ray.

12/4/2015

Re: SPR 268493: permission to use image [code=B2AE4] - Raymond Brunkow

Re: SPR 268493: permission to use image [code=B2AE4]

Maxim Support <support-center@support.maximintegrated.com>

Wed 11/11/2015 6:09 PM

To: Raymond Brunkow <rbrunkow@knights.ucf.edu>;

=====

| SPR 268493 - Staff Response - Maxim Support Center

| The most recent Maxim reply to your request follows below.

| If you wish to reply, you can use this fast, secure webform:

| <https://support.maximintegrated.com/rtd/reply.mvp?id=268493&code=B2AE436288>

| or you can reply via e-mail. When you reply by e-mail, do not

| modify the subject line. It must contain the SPR number.

| Your response text must be at the Very Beginning of your reply.

=====

| Staff Comment 2015-11-11 17:09:50 PST

| By: Christie B

| Hi Raymond,

| That is not a problem at all. Please feel free to use any  
| information you find on our website as long as you reference us  
| as the source.

| Best regards,  
| Christie Bay  
| Customer Operations

=====

| Submit Request 2015-11-11 16:50:40 PST

| By: rbrunkow@knights.ucf.edu

| Greetings, my name is Ray Brunkow and I am a senior at the  
| University of Central Florida (UCF) participating in senior  
| design I this semester. This requires students to work in groups  
| to create a document for their project. Our project is to  
| completely redesign the electronics for the Limbitless Solutions  
| group: <http://limbitless-solutions.org/index.php/en/>, these are  
| the folks who create low cost robotic hands for children. The  
| folks who worked with the actor Robert Downey Jr in this video:  
| [https://www.youtube.com/watch?v=oEx5lmbCKtY&ab\\_channel=OfficeVide](https://www.youtube.com/watch?v=oEx5lmbCKtY&ab_channel=OfficeVide)

| os

https://outlook.office.com/owa/?cdn=1&ver=16.983.14.1854548&bFS=1#viewmodel=ReadMessageItem&ItemID=AAMkAGM0ZDE... 1/2

12/4/2015

Re: SPR 268493: permission to use image [code=B2AE4] - Raymond Brunkow

| My portion of the paper includes updating the charging for the  
| battery. I would like permission to use two of your images in  
| our paper.

| <https://www.maximintegrated.com/en/images/appnotes/3241/3241Fig03.gif>

| and

| <https://www.maximintegrated.com/en/images/appnotes/3241/3241Fig04.gif>

| Thank you in advance for reading this request.

=====

| REFERENCES

| Referring Url:

| <https://www.maximintegrated.com/en/aboutus/contact-us.html>

| Maxim Support Center:

| <https://support.maximintegrated.com/>

| Maxim Home Page:

| <http://www.maximintegrated.com/>

=====

## Appendix C – Datasheets

See supporting documentation for the following datasheets:

<b>Component</b>	<b>Part Number</b>
EMG AFE	ADS1293
Haptic Driver	DRV2605
LRA Actuator	N/A
MCU	CC2650
Servo	Tower Pro MG995
Wireless Transmitter	BQ500215
Wireless Receiver	BQ51025
LiOn Charger	BQ24120
DC/DC Buck Converter	TPS65257
Overcharge Protection	BQ771605

## Appendix D – References

- "FRAM FAQs." *Texas Instruments*. 2014. Web. 12 Aug. 2015.  
<<http://www.ti.com/lit/ml/slat151/slat151.pdf>>.
- "LPC1769 Datasheet." *NXP Semiconductors*. 18 Aug. 2015. Web. 13 Sept. 2015.  
<[http://www.nxp.com/documents/data\\_sheet/LPC1769\\_68\\_67\\_66\\_65\\_64\\_63.pdf](http://www.nxp.com/documents/data_sheet/LPC1769_68_67_66_65_64_63.pdf)>.
- "ARM Information Center." *ARM Information Center*. 2006. Web. 31 Oct. 2015.
- "How WiFi Works." *HowStuffWorks*. 29 Apr. 2001. Web. 6 Aug. 2015.  
<<http://computer.howstuffworks.com/wireless-network1.htm>>.
- "About Near Field Communication." *About Near Field Communication*. Web. 4 Dec. 2015. <<http://www.nearfieldcommunication.org/about-nfc.html>>.
- "Near Field Communication versus Bluetooth." – *NearFieldCommunication.org*. Web. 4 Dec. 2015.  
<<http://www.nearfieldcommunication.org/bluetooth.html>>.
- "Bluetooth Insight." *Bluetooth Power Classes: Class 1, 2 and 3*. 11 Jan. 2008. Web. 4 Dec. 2015.  
<<http://bluetoothinsight.blogspot.com/2008/01/bluetooth-power-classes.html>>.
- Ultra-Wideband." *Wikipedia*. Wikimedia Foundation. Web. 4 Dec. 2015.  
<<https://en.wikipedia.org/wiki/Ultra-wideband>>.
- Wexler, Joanie. "Bluetooth and ZigBee: Their Similarities and Differences." *Network World*. 28 Feb. 2005. Web. 14 Aug. 2015.  
<<http://www.networkworld.com/article/2318704/network-security/bluetooth-and-zigbee--their-similarities-and-differences.html>>.
- Foerster, Green, Somayazulu, and Leeper. "Ultra-Wideband Technology for Short- or Medium-Range Wireless Communications." *Colorado State University*. 12 Apr. 2001. Web. 4 Oct. 2015.  
<[http://ecee.colorado.edu/~ecen4242/marko/UWB/UWB/art\\_4.pdf](http://ecee.colorado.edu/~ecen4242/marko/UWB/UWB/art_4.pdf)>.
- Ferroelectric RAM." *Wikipedia*. Wikimedia Foundation. Web. 3 Oct. 2015.  
<[https://en.wikipedia.org/wiki/Ferroelectric\\_RAM](https://en.wikipedia.org/wiki/Ferroelectric_RAM)>.
- "Adding and Improving Haptics." *Precision Microdrives*. 2015. Web. 4 Dec. 2015.  
<<http://www.precisionmicrodrives.com/haptics-haptic-feedback-vibration-alerting/haptic-feedback-in-detail/adding-and-improving-haptic-feedback>>.
- Zahak, Muhammad. "Signal Acquisition Using Surface EMG and Circuit Design Considerations for Robotic Prosthesis." *Computational Intelligence in*

*Electromyography Analysis - A Perspective on Current Applications and Future Challenges* (2012). Print.

"Electromyography (EMG)." *Mayo Clinic*. Mayo Clinic, 25 Oct. 2012. Web. 4 Dec. 2015. <<http://www.mayoclinic.org/tests-procedures/electroconvulsive-therapy/basics/definition/prc-20014183>>.

"Force Sensitive Resistor (FSR)." *Using an FSR*. 29 July 2012. Web. 4 Dec. 2015. <<https://learn.adafruit.com/force-sensitive-resistor-fsr/using-an-fsr>>.

"Flex Sensor FS." *SparkFun*. Web. 4 Dec. 2015. <<https://www.sparkfun.com/datasheets/Sensors/Flex/flex22.pdf>>.

"Stepper vs. Servo." AMCI : Tech Tutorials : Stepper vs. Servo. Web. 4 Nov. 2015.

"Dell to Recall 4 Million Batteries - CNET." CNET. Web. 4 Nov. 2015.

"Charging Batteries Using USB Power." - Reference Schematic. Web. 4 Nov. 2015.

"Charging Batteries Using USB Power." - Reference Schematic. Web. 4 Nov. 2015.