

# Head On

Amber Farrell, Larry Herman, Cristhian Marin,  
Aurora Reinefeld

Department of Electrical Engineering and  
Computer Science, University of Central  
Florida, Orlando, Florida, 32816-2450

**Abstract** — The objective of this project is to integrate existing technologies into add-on solution for motorcyclists. The solution is expected to improve the riding experience while heightening the rider's situational awareness through features which include obstacle detection, speed tracking, and cardinal directional detection. The group chose this project in order to reach out to an untouched consumer market while incorporating each member's computer and electrical engineering backgrounds.

**Index Terms** — HUD, Ultrasonic sensor, Solar power, LiPo, Bluetooth, GPS, Accelerometer/Magnetometer

## I. INTRODUCTION

It is an undeniable fact that electrical and computer engineers have made the greatest contribution to the current technology sector. This impact has been revolutionary and has paved the way for products that have transformed the quality of life for many. As the members of this team near the beginning of their electrical and computer engineering careers, this group wanted to create a senior design project that focuses on taking existing technology and improving its current use for the users.

In particular, this design focuses on the motorcycle community. The main objective for this project is to improve the riding experience by increasing the situational awareness and, consequently, safety of the rider. The design of this system consists of two parts. The first part incorporates a typical full face motorcycle helmet, which is then modified to contain a display. This screen will display relevant information to the user about his or her surroundings, motorcycle, and other general information. The second unit of Head On will be fitted on the motorcycle itself. This unit will contain several modules that will be used to take in data; once all of the data is gathered, it will then be transmitted to the helmet system so that it can be analyzed and displayed to the user. The combination of these two units will provide the rider with features that increase his or her enjoyment, safety, and secureness in the motorcycle.

This document describes the design decisions made and the factors that lead to these decisions. A detailed

description of each component of this project will be provided in the following sections. This will be followed by an explanation of the design of the system, as well as how the hardware and software of the prototype will interact.

## II. SYSTEM COMPONENTS

This section seeks to provide users with an overview to the Head On system design and a breakdown of the components and peripherals which make up the motorcycle and helmet units. The group's intention with this project was not to create a new technology, but rather to combine existing technology into a solution that all motorcyclists could one day benefit from on their commutes. Through the presentation of each individual component, one can gain a clear understanding of what drives the Head On system.

### A. Microcontroller

When designing the Head On system, particular attention was needed in selection of the microcontroller (MCU). This selection was crucial as it is the centralized unit which controls how the system handles peripheral data and communication between the helmet and motorcycle units. The selection of this component was narrowed by factors such as pin count, power consumption, and footprint. The main candidates included the ARM processor STM32F405VG, Atmel's ATmega328 and ATmega1280, and the Texas Instruments' MSP430. After considering the factor previously mentioned, the group found that both the ATmega328 and MSP430 were perfect fits. In the end, the ATmega328 was chosen based on preference for the large resource availability and the ease of use of Arduino IDE.

When researching the right selection for an MCU, the group found the ATmega328 especially appealing for its diversified features. Specifically, this MCU included a generous count of analog and digital pins (23 I/O pins total), low power consumption (and various power modes), sufficient memory to handle the program and data, and an I2C bus. The specs on this chip were not as impressive as its counterpart, the ATmega1280; however, it provided plenty of flexibility to handle many more components than planned all the while keeping a focus on low power consumption. In order to keep consistency the ATmega328 was chosen for both the helmet and motorcycle unit.

Another benefit for implementing the ATmega328 was the use of the C programming language which all group members were familiar with from previous coursework. Additionally, this MCU has a large following as it is featured in the Arduino Uno. This not only provided the

support from various documentations, communities, and previous implementations, but also the ability to use the Uno as a development board for initial testing.

### *B. GPS*

One of the main features of Head On is displaying accurate speed to the user which reduces a rider's need to look down at gauges dramatically. At first, accessing the speed directly from the motorcycle's ECU was considered; however, this would be a highly intrusive design which may not have been possible to implement. Additionally, taking the speed directly from this source would also mean that the speed displayed to the user would be as inaccurate as the gauges. As an alternate, global positioning system (GPS) technology was chosen because of its ability to use multiple satellites virtually anywhere to retrieve data, such as moving speed and location. Furthermore, by utilizing GPS technology the system would be able to show the true speed of the motorcycle in contrast to the gauge which is affected by the error from factory specifications, tire wear, road conditions, and gearing.

Three various GPS chipsets were considered for the application. Each of these chipsets differed in power consumption and size. The final choice, the PA6H, was selected as it provided the lowest power consumption with specifications of 25 mA and 20 mA for acquisition and tracking, respectively. Integration of this chipset also allows rider's to have relatively quick speed readings upon system power on for acquisition time on a cold start was typically 34 seconds. Additionally, this chipset is functional with the TinyGPS library for ease of retrieving and parsing the raw NMEA data output. Finally, the PA6H is featured on Adafruit's Ultimate GPS Shield, which could be used to speed up the developmental stage during which the Arduino Uno is used.

### *C. Compass*

Later in the design process, it was determined that the GPS module would only be able to provide the cardinal direction when the rider is moving. As a result, the design of the system had to be modified to include a compass module in order to provide this information to the rider continuously. Head On design allowed for the compass to either be placed on the motorcycle unit or the helmet unit; however, after extensive consideration the group decided to place the compass on the helmet unit. This placement allowed the rider to be aware of the direction his or her eyes are looking at rather than being fixed on where the motorcycle is heading. The chosen module, LSM303D Ultra-compact high-performance eCompass, is an integrated 3-axis accelerometer and 3-axis magnetometer. It is designed for use in tilt-compensated compasses as

well as several other position and rotation detection applications. The output of the module is accessible via either an I2C or SPI serial interface. This module also has a built in FIFO buffer that is intended to reduce power consumption. By having the sensor data ready for transmission it eliminates the need for the MCU to constantly poll the sensor for data.

### *D. Ultrasonic Sensor*

After researching a variety of possible approaches to detect hazards around the rider, such as infrared, radar, and ultrasonic detection, it was determined that utilizing ultrasonic sensors would be the best option. The ultrasonic detection systems were found to have an ideal detection range for the system's side proximity detection, as well as an adequate range for the rear proximity detection. Additionally, the frequency and pulse modulation scheme of ultrasonic sensors minimizes the possibility of external interference, while the highly directional nature of the sensors prevents mutual interference of properly positioned sensors.

Detection distance was the primary factor taken into consideration when making the final selection. Based off of the Federal Highway Administration's standard road widths, it was determined that the left and right facing sensors should be able to detect objects that are at least 3.6m away since this is the typical road width. Originally, the HC-SR04 sensors were selected because they are supposed to detect objects up to 4m. However, after several tests were run, it was determined not only that object detection using these sensors was unreliable after approximately 1m, but interference between the three sensors would also be an issue. Therefore, the design was modified in order to use the LV-MaxSonar-EZ 1010 sensors instead. These sensors can reach up to 6.45m, which is sufficient for the left, right, and rear vehicle detection.

There are multiple methods in which the sensors can be connected and data gathered. For this project, the three sensors are chained together and triggered with a single pin. This format was chosen because it requires fewer pins than connecting and triggering each sensor individually. The group determined that this reduced number of pins would be favorable for the design because it would allow more pins available for modifications should the design of the system need to be changed. Additionally, another benefit of the chaining method is that it produces a more accurate result and addresses the issue of cross-talk amongst the multiple sensors. Only one sensor will be producing a signal and reading data at a time. Once the data is received that sensor then sends the trigger to the next sensor in the chain so that it can send its pulse.

### E. Bluetooth

In designing the Head On system, it was determined that it would be best to keep two separate units: a helmet and motorcycle unit. The separation into two subsystems required a way to maintain communication that would be reliable and efficient. Initially, wired technology was researched; however, it was quickly ruled out due to safety concerns about tethering the rider to the motorcycle. Several wireless technologies were available such as Wi-Fi and ZigBee; however, in the end, Bluetooth implementation was chosen for this project. Bluetooth fit this application as it provided a quick and easy network setup, sufficient operating range (assuming a Class 2 or Class 3 device is used), and mid-range data throughput to handle the various component data compared to its counterparts illustrated in Table 1. These factors were all of great importance to group, yet none was as crucial as the last factor: data throughput. The reasoning behind needing ample data throughput was the placement of the ultrasonic sensors and GPS on the motorcycle unit. These two components were set to refresh continuously at fast rates which with less than necessary space on the communication could result bottlenecking. Bottlenecking of a device such as Head On could mean the difference between avoiding dangers and getting in a serious accident because the user made a decision based on delayed data. Moreover, since Bluetooth is a mature technology with standards overseen by the Bluetooth Special Interest Group, the group would have no difficulty finding relevant documentation

Attribute	Wi-Fi	Bluetooth	ZigBee
<b>Standard</b>	802.11 (a,b,g,n)	802.15.1	802.15.4
<b>Frequency</b>	2.4/5GHz	2.4 GHz	2.4 GHz
<b>Operating Range</b>	100 meters	10 meters	10-100 meters
<b>Power Consumption</b>	High	Medium	Low
<b>Data Throughput</b>	25 Mbps	0.7-2.1 Mbps	250 kbps
<b>Network Acquisition</b>	3-5 s	< 10 s	30 ms

Table 1. Wireless Communication Technology Comparison

After filtering through several Bluetooth modules, the group chose to implement the HC-05 module into this design. The HC-05 module was chosen for both simplicity, easy availability, low cost, operating behavior, and ample reference availability. Bluetooth falls into various power classes ranging from 1 to 3 that determine its maximum power drain and operating range. Operating on Class 2,

this module enabled an operating range of up to 10 meters with a low power consumption of 2.5 mW maximum. Furthermore, the HC-05 was capable of a master or slave operation in contrast to the HC-06 module considered, which only operates in slave mode. The module provided two modes, AT mode and data mode. AT mode allowed the group to change the pairing pin and module name, link to another module manually, and even bind two units together for automatic pairing. This characteristic gave the group versatility when it came to piconet setup by allowing the helmet or motorcycle unit to be set as master or slave as needed. Once modules became paired, the group could then utilize the available data mode from the HC-05 for communication between the two subsystem PCBs. Pin count was also in the interest of the group due to the limited availability of pins on the ATmega328. Fortunately, this module only required two digital pins, power, and ground. Finally, the wide availability of references allowed the group to understand module setup and Bluetooth data communication, as well as troubleshoot any issues that may arise with the module, such as pairing failure.

### F. RTC

When programming the time on the display, the ATmega328 could not be relied on to keep time. Specifically, the ATmega328 only keeps time relative to itself and would lose track of time during power loss. As a solution to accurately display the time to the user, it was determined that a real time clock module would be necessary. The selected DS3231M real time clock utilizes an internal Temperature Controlled Crystal Oscillator (TCXO) to maintain a clock accuracy of +/- 2 minutes per year. The clock time is selectable in either the 24-hour or 12-hour AM/PM format. The Head On system will use the traditional 12-hour system. Additionally, this module is equipped with direct connection for a backup battery, which is used in order to prevent the user from having to reset the time each use. In the event that the time is not set, the user will be able to set the time using the two buttons build into the system.

### G. Display

Perhaps one of the most important components of the system is the display. The size of the screen was particularly important because both the Snell Memorial Foundation and the Department of Transportation have standards that dictate what the rider's field of view must be. Originally projecting the indicators directly onto the rider's helmet was considered, but since none of the group members have a background in optics, an alternative had to be determined. In the end, the Adafruit 2.2" TFT LCD display was chosen for this project because it provides sufficient space to display all of the information to the

rider, while still being small enough that it does not block the rider's view.

This display has 320x240 color pixels which allows for a dynamic user interface to be developed. Using the graphics library available for this screen, indicators are displayed on the screen based on the data gathered from the modules.

Once the module data is analyzed, the appropriate indicator signals are displayed on the LCD display, as shown in Figure 1 below. The three proximity sensor bars correspond to the three ultrasonic sensors found on the motorcycle unit. Each indicator will only be displayed if an object is detected by the corresponding ultrasonic sensor. Additionally, the proximity indicators will vary in color, from yellow to red, depending on how close the hazard is to the rider. Other features of the user interface include the time, displayed in 12-hour format, and the speed, given in miles per hour. The final indicator on the screen is the cardinal direction indicator which displays the direction that the rider is looking using both the compass symbol and the letter.



Fig. 1. User Interface

The two push buttons mentioned previously in this paper can be used to interact with the user interface. Currently, these buttons can be used to set the time as well as modify the brightness of the display.

#### H. Power Source

As previously mentioned, the Head On system consists of two units, one on the motorcycle itself and the other on the helmet the rider wears. Hence, it was necessary to design a power supply for each of the two units. The helmet unit runs on power gathered from two sources in order to ensure that the rider has several options to charge the system. Solar cells located on top of the helmet are used to harvest energy even when the rider is using the system. The second source of power for the helmet system is the lithium polymer battery which can be connected using an external barrel connected charger. On the other hand, the motorcycle unit is powered only by one source, the 12V battery on the motorcycle.

By taking into account all of the components that make up the helmet unit, it was determined that the current requirement is 0.18A. However, this was not the only factor that had to be considered when selecting a solar panel. Both the Snell Memorial Foundation and the Department of Transportation have standards which restrict the size of attachments placed on helmets. Any object that is placed on the helmet must not protrude more than 5mm. As a result, the solar panels must be extremely flexible so that they can conform to the shape of the helmet. With this current requirement in mind, as well as the size constraint and curved shape of the helmet, PowerFilm Solar's MPT4.8-75 flexible solar panel was selected. Each panel puts out 50 mA at 4.8V and is 3.7 inches by 2.87 inches. Due to the amount of current the helmet unit components draw, four panels connected in parallel were attached to the apex of the helmet. This configuration, shown in Figure 2 allows for the panels to receive the maximum amount of sunlight while leaving enough space for one more panel to be added if needed.



Fig. 2. Panel placement on helmet.

In order to maximize the power taken from the solar cells Texas Instrument's BQ25505 energy harvesting chip was selected to harvest the power from the cells. It serves as a boost converter with continuous energy harvesting from as low as 100 mV and has integrated battery management in the form of overvoltage and under voltage protection as well as thermal shutdown. Therefore, it is capable of harvesting the energy from the solar cells, powering the system, and charging the 3.7V 2000 mAh lithium polymer rechargeable battery that was selected for this project.

Since all of the components on the helmet unit run on 3.3V and the outputs from the solar cells and the battery are both higher than that, Texas Instrument's TPS62737 buck converter was chosen to regulate the voltage. This will ensure that components are not accidentally damaged by having the wrong voltage applied to them.

Instead of choosing an alternate source of power for the motorcycle unit, it was deemed simpler to use the existing

12V battery on the motorcycle. It provides ample power without the need for an external source. However, since the components that make up the motorcycle unit all run on 3.3V the voltage needs to be regulated. Texas Instrument's TPS54292 dual buck converter was chosen to regulate the voltage. It has a dual output capability which allows for output of both 3.3V and 5V. Only the 3.3V output is being used for the Head On system, but the 5V output is available for future addition of features and components. Table 2 summarizes the parts used for the two power systems for reference.

Component	Function	Location
MPT4.8-75 flexible solar panels	Power helmet system	Helmet
LiPo Battery	Secondary power source for helmet system	Helmet
BQ25505	Energy harvester and battery charger	Helmet
TPS62737	Buck converter	Helmet
TPS54292	Dual buck converter	Motorcycle

Table 2. Power System Components

### III. SOFTWARE DETAIL

After gaining an understanding of each physical component's behavior, it is necessary to present the software that enables all of these components to function together. As previously mentioned, the Head On system is based on integration of existing technology to enhance the rider's situational awareness. The software for both the helmet and motorcycle unit was designed to combine these specialized devices into "one device" that provides accurate time, direction, speed, and obstacle detection.

#### A. Helmet Unit

Just as the helmet unit's Bluetooth module was made the master in the piconet, the helmet unit was made the master in the software and data handling. As summarized in Figure 3, the helmet MCU is set to continuously check for Bluetooth data sent from the motorcycle unit, parse it if available, and update the screen with values from the local components and newly parsed values. In an effort to enhance usability, this system also implements input handling for users to set the RTC's time or switch into various display modes which are trigger by onboard buttons.

The Helmet unit's primary function is to determine how the screen must be updated based on the data gathered from each module. For both the time and the speed indicators, the helmet must simply display the values onto

the screen once they have been converted to the proper format. On the other hand, for each of the ultrasonic sensors, the data must first be compared to various thresholds, shown in Table 3, in order to determine if the corresponding indicator should be displayed, and if so what color the indicator should be. These values were determined based on the standard road widths. Assuming that the rider is in the center of his lane, an object that is 400cm or less would pose an immediate danger to the rider. Similarly, if the object is greater than 400 but less than 600 the object could pose a danger to the rider, but it is not as significant. Based on tests performed on the sensors, after about 600cm the data gathered from the sensor is no longer accurate enough to determine if an object is present.

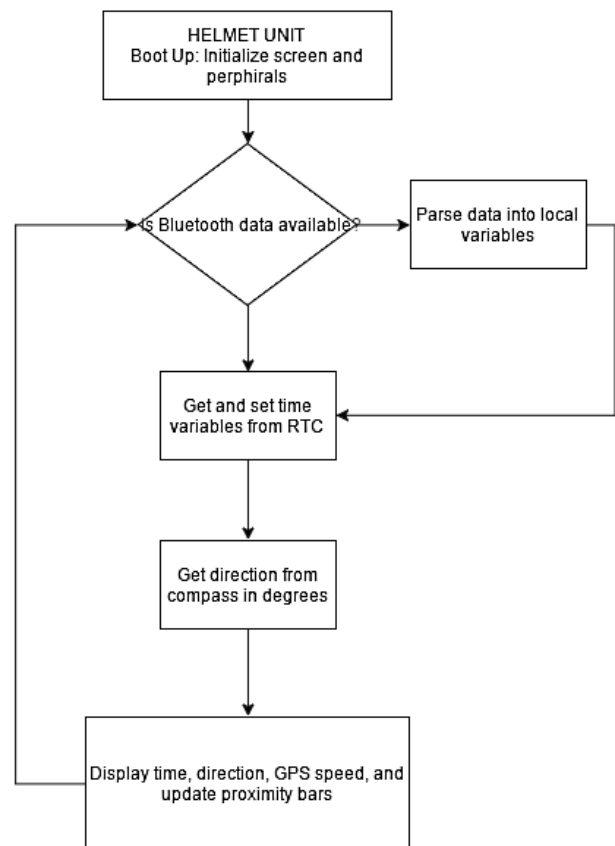

Fig. 3. Helmet Unit Software Flowchart

Detection Distance (cm)	Indicator color
>600	None
400-600	Yellow
<400	Red

Table 3. Object Detection Indicator Ranges

Similarly, before the cardinal direction indicator is updated, the data collected from the compass module must first be converted using Equation 1. The magnetic readings in the y and z access must be taken and then converted into degrees.

$$data = (atan2(yData, -zData) * 180) / \pi; \quad (1)$$

Because the compass module is placed on PCB, which is located on the back of the rider's helmet, it will be displaying the direction that the rider is facing. Additionally, since the module will be vertical, the y and z axes, displayed in Figure 4, must be used to calculate the direction in degrees rather than the x and y axis.



Fig 4. Cardinal Module Orientation

Requesting Permission in Progress

The resulting value is then compared to the ranges shown in Table 3 in order to determine the direction; the screen is then updated with the appropriate set of symbols.

Direction	Data (°)
North	338-22
North East	23-67
East	68-112
South East	113-157
South	158-202
South West	203-247
West	248-292
North West	293-337

Table 4. Cardinal Direction Ranges

### B. Motorcycle Unit

In contrast to the helmet unit, the motorcycle unit is set up as the slave unit. Its only function is to send data gathered from the ultrasonic sensors and GPS modules to the helmet unit. In the programming, illustrated in Figure 5, a trigger initializes the sensor chain, and then the GPS speed is retrieved from GPS and converted from knots to MPH as defined by Equation 2. Finally the individual sensor distances are retrieved and stored. While cycling through all three sensors, the program utilizes Equation 3 to convert the output pulse of the sensor to centimeters.

$$mph = knot * 1.150 \quad (2)$$

$$cm = (pulse/147) * 2.54 \quad (3)$$

Once the final sensor value is received the data is then formatted and sent to the helmet module using Bluetooth. In order to make parsing in the helmet accurate and simple, the Bluetooth data is organized as a data sentence in the form of a string variable. The format sent appears as, "[GPS speed], [Sensor 1 dist.], [Sensor 2 dist.], [Sensor 3 dist.]." This format allows the helmet to utilize existing string library functions to split the data retrieved from the motorcycle peripherals into variables that are displayed on the screen.

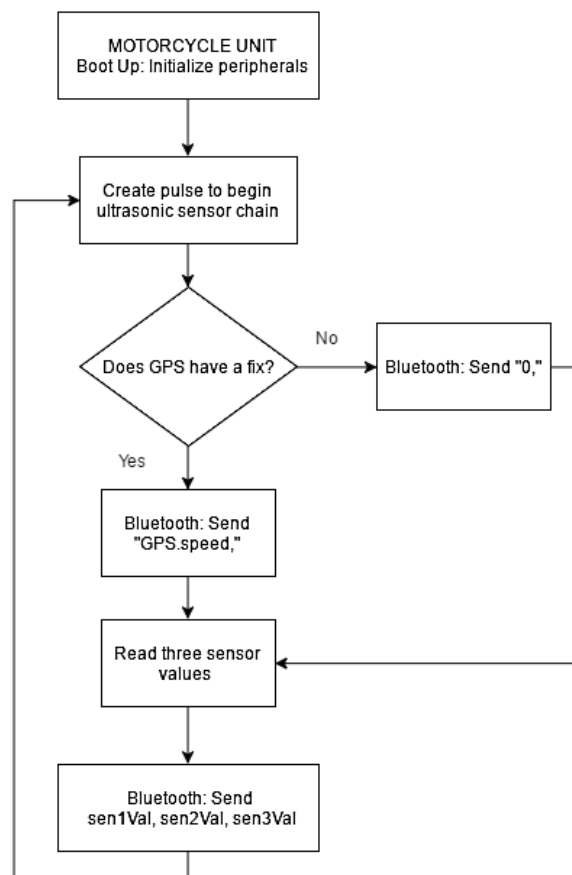

Fig. 5. Motorcycle Unit Software Flowchart

## IV. HARDWARE DETAIL

After selecting all of the necessary components, a design was made for the two units. The block diagrams seen in Figure 6 and Figure 7 outline the connections between the components. Please note that the connection between the power source and each of the components is implied.

### A. Helmet Unit

As previously discussed, the helmet unit will run on solar power while it is available and on the battery when solar power is not available. The power control is made up of the BQ25505 solar energy harvesting chip and the TPS62737 buck converter. These two methods will be used to power the compass module, real time clock, display, and Bluetooth module. All of the connections of these modules and power sources are illustrated in Figure 6. The compass module, power chips, real time clock, and Bluetooth modules will all be mounted directly to the PCB. However, because the display must be located in front of the user, it will be connected to the PCB on the back of the helmet using a ribbon cable. The display will be held in place using a modified GoPro mount.

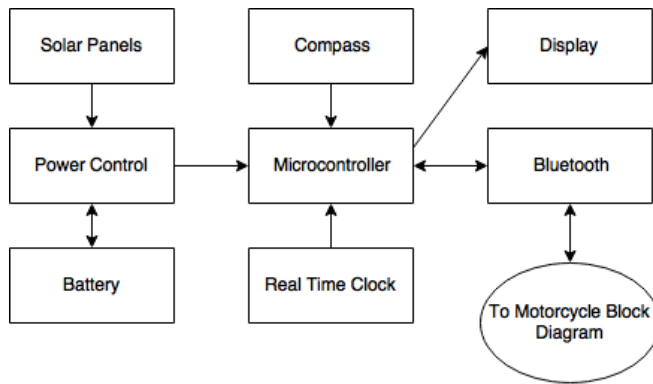

Fig. 6. Helmet Unit Hardware Block Diagram

### B. Motorcycle Unit

On the other hand, the motorcycle unit will be powered using the battery that is already on the motorcycle. This greatly simplifies the design for the power supply since only a power regulator is needed. The TPS54292 dual buck converter is suitable for the job. Additionally, because the TPS54292 has both a 3.3V and a 5V output, it leaves the option of adding future components to the system that require either of these voltages. The GPS module, Bluetooth module, and three proximity sensors, shown in Figure 7, will be connected to the microcontroller and powered by the 3.3V from the buck converter. The power regulator, Bluetooth module, and GPS module will be mounted directly to the PCB. On the other hand, in order to position the sensors so that they can detect objects in all of the user's blind-spots, they will be connected to the PCB via a ribbon cable. Not only will this layout ensure that the three blind-spots are covered, it will also reduce the chance of interference between the sensors.

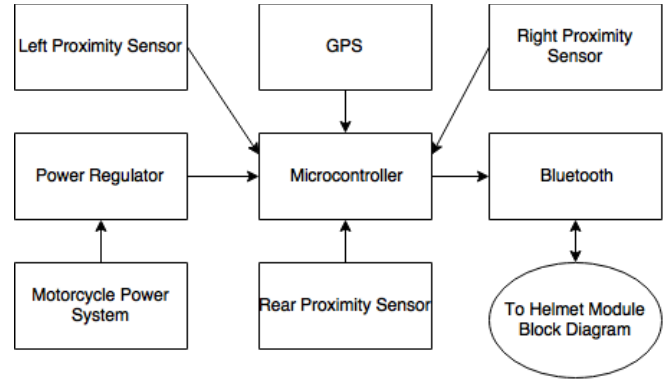

Fig. 7. Motorcycle Unit Hardware Block Diagram

## V. PRINTED CIRCUIT BOARD

The PCBs were laid out from schematic diagrams designed using Eagle CAD software. Despite difficulty routing the signals on the helmet module board, both PCBs we kept to a simple two-layer design. The ground plane on both sides of the boards was kept as large as possible to reduce EMF and maximize heat dissipation for the power supplies. The board were commercially produced and four miniature surface mount packages were installed by a local manufacturing company.

## VI. CONCLUSION

In summation, the Head On system was a collaborative effort to create a product that could enhance the riding experience for motorcycle enthusiasts. By applying knowledge gathered from classes taken, the system was designed and prototyped successfully.

The goal of this project was to incorporate some of the technologies available for automobiles into an easy to use system which a motorcycle rider can use while on the go. The team was successful in this regard. The first and arguably the most important feature to be incorporated into the system is the hazard detection. Proximity sensing of vehicles and other hazards in the motorcycle's blind spots is accurately displayed on the screen using indicators. Additionally, in order to further enhance the rider's experience, the cardinal direction, time and, speed are also accurately displayed. In the end, all of the planned features for the Head On system were successfully completed.

Given more time and funding there are multiple other features that could be integrated into this system. The two additions that would likely be first integrated would be a step by step navigation system that could be displayed on the screen as well as a system that alerts the rider's emergency contacts if he or she were to get into an accident. Other possible design enhancements include

actually projecting the display onto a section of the motorcycle visor instead of using an LCD.

#### VII. ACKNOWLEDGEMENT

The authors wish to acknowledge Boeing and Leidos for generously agreeing to sponsor this project. Additionally, the group would like to thank Dr. Richie and Dr. Lei Wei for their time and guidance throughout the development of this project. Finally, the group wishes to extend their thanks to Quality Manufacturing Services for their assistance in mounting components to the final printed circuit boards.

#### VIII. BIOGRAPHY



**Amber Farrell** is currently a senior at the University of Central Florida. She plans to graduate with her Bachelor of Sciences in Computer Engineering in May of 2016. She is pursuing a career in the computer engineering profession with an emphasis on embedded systems.



**Larry Herman** is currently a senior at the University of Central Florida. He will receive his Bachelor of Sciences in Electrical Engineering in 2016. He is interested in advancing his career in Metrology. Building on his practical experience in a U.S. Air Force Precision Measurement Laboratory to

take on a research and development role at a national standards laboratory or test equipment manufacturer.



**Cristhian Marin** is currently a senior at the University of Central Florida. He is majoring in computer engineering and will be graduating in May 2016. He is pursuing a career in computer engineering with a focus on software development. Cristhian hopes to return later on for his MBA.



**Aurora Reinefeld** is a senior at the University of Central Florida. She will receive her Bachelor of Sciences in Electrical Engineering in 2016. She is pursuing a career in Electrical Engineering with a concentration on power distribution design. She hopes to return to get her Master's in Engineering

Management.

#### IX. REFERENCES

- [1] Snell Memorial Foundation. "Snell Foundation - M2015 Helmet Standard." *M2015 Helmet Standard*. Snell Memorial Foundation, 2015. Web. 07 Dec. 2015.
- [2] United States. U.S. Department of Transportation. Federal Highway Administration. *Mitigation Strategies For Design Exceptions*. By Federal Highway Administration. Federal Highway Administration, 15 Oct. 2014. Web. 7 Dec. 2015.
- [3] United States. National Highway Traffic Safety Administration. Department of Transportation. *49 CFR 571.218 - Standard No. 218; Motorcycle Helmets*. By Department of Transportation. Department of Transportation, 1 Oct. 2011. Web. 7 Dec. 2015.