



QUANSER
INNOVATE. EDUCATE.



Quanser Ball and Beam

User Manual

BB01

Quanser Inc.

2011

© 2011 Quanser Inc., All rights reserved.

Quanser Inc.
119 Spy Court
Markham, Ontario
L3R 5H6
Canada
info@quanser.com
Phone: 1-905-940-3575
Fax: 1-905-940-3576

Printed in Markham, Ontario.

For more information on the solutions Quanser Inc. offers, please visit the web site at:
<http://www.quanser.com>

This document and the software described in it are provided subject to a license agreement. Neither the software nor this document may be used or copied except as specified under the terms of that license agreement. All rights are reserved and no part may be reproduced, stored in a retrieval system or transmitted in any form or by any means, electronic, mechanical, photocopying, recording, or otherwise, without the prior written permission of Quanser Inc.

CONTENTS

1	Presentation	4
1.1	Description	4
1.2	Remote Sensor Option	4
2	Components	5
2.1	Component Nomenclature	5
2.2	Component Description	5
3	Specifications	7
4	System Setup	8
4.1	Assembly	8
4.2	Calibration	8
5	Wiring Procedure	11
5.1	Cable Nomenclature	11
5.2	Connections using VoltPAQ-X1	11
5.3	Connections with the VoltPAQ-X2	13
6	Testing and Troubleshooting	17
6.1	SRV02 Motor and Encoder	17
6.2	Ball Position Sensor	17
7	Technical Support	19

1 PRESENTATION

1.1 Description

The Quanser Ball and Beam module, pictured in Figure 1.1, consists a track on which the metal ball is free to roll. The track is fitted with a linear transducer to measure the position of the ball, i.e., it outputs a voltage signal proportional to the position of the ball. One side of the beam is attached to a lever arm that can be coupled to the load gear of the Quanser SRV02 unit. By controlling the position of the servo, the beam angle can be adjusted to balance the ball to a desired position.



Figure 1.1: Quanser BB01 system

1.2 Remote Sensor Option

The SRV02 Ball and Beam module can also be accompanied by a remote ball sensor called the SS01 module. This permits a master-slave configuration where the ball command is generated by the SS01 instead of through a program.

2 COMPONENTS

The Ball and Beam components are identified in Section 2.1. Some of those components are then described in Section 2.2.

2.1 Component Nomenclature

The components of the Ball and Beam module, i.e., the BB01 device, and the Remote Sensor system, i.e., SS01, are listed in Table 2.1 and labeled in Figure 2.1 and Figure 2.2.

ID	Component	ID	Component
1	SRV02	8	Support base
2	Lever arm	9	Analog ball position sensor connector
3	Coupling screw	10	Support arm screws
4	Steel ball	11	Calibration base
5	BB01 Potentiometer sensor	12	SS01 Potentiometer sensor
6	BB01 Steel rod	13	SS01 Steel rod
7	Support arm	14	Analog remote sensor connector

Table 2.1: Listing of BB01 and SS01 Components

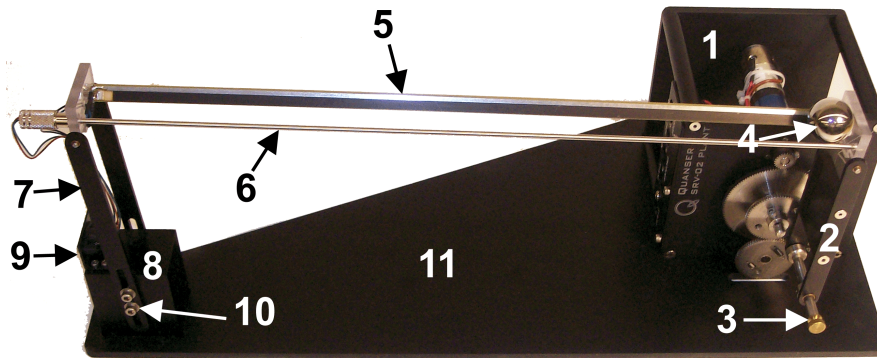

Figure 2.1: Components on Ball and Beam system

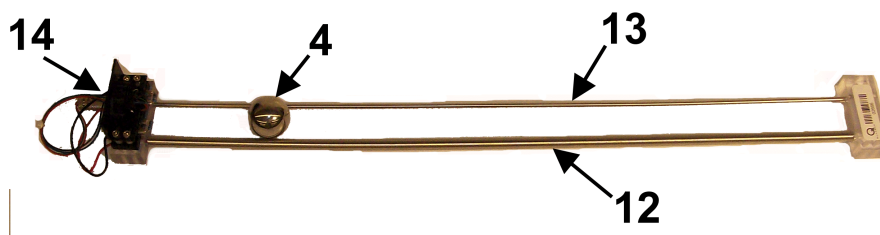

Figure 2.2: Components on Remote Sensor system

2.2 Component Description

2.2.1 Ball Position Sensor

The track of the BB01 linear transducer module on which the metal ball is free to roll consists of a steel rod in parallel with a nickel-chromium wire-wound resistor forming the track. The resistive wire is the black strip that is stuck on the plastic which is fastened onto the metal frame. The position of the ball is obtained by measuring the voltage at the steel rod. When the ball rolls along the track, it acts as a wiper similar to a potentiometer resulting in the position of the ball.

■ **Caution:** Regular cleaning of the beam is recommended to ensure proper operation of the ball and beam experiment. Clean both the beam and the steel ball using rubbing alcohol.

2.2.2 Remote Sensor

Similarly to the BB01, the SS01 has a wiper potentiometer sensor that detects the position of the ball.

3 SPECIFICATIONS

Table 3.1 lists and characterizes the main parameters associated with the BB01. See Figure 3.1 for an illustration of the Ball and Beam dimensions and the variables α , θ , and x that are associated with the system. Some of the parameters listed in Table 3.1 are used in the mathematical model.

Symbol	Description	Matlab Variable	Value
	Mass of ball beam module		0.65 kg
	Calibration base length		50 cm
	Calibration base depth		22.5 cm
L_{beam}	Beam length	L_beam	42.55 cm
	Lever arm length		12.0 cm
r_{arm}	Distance between SRV02 output gear shaft and coupled joint	r_arm	2.54 cm
	Support arm length		16.0 cm
r_b	Radius of ball	r_ball	1.27 cm
m_b	Mass of ball	m_ball	0.064 kg
K_{bs}	Ball position sensor sensitivity	K_BS	-4.25 cm/V
V_{bias}	Ball position sensor bias power		± 12 V
V_{range}	Ball position sensor measurement range		± 5 V

Table 3.1: Ball and Beam specifications

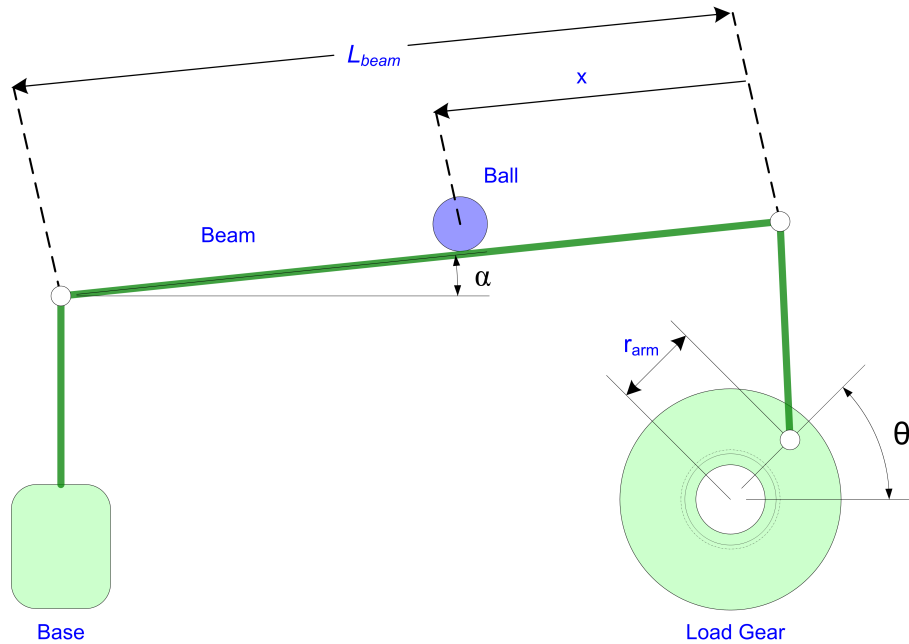

Figure 3.1: Ball and beam lengths and variables

4 SYSTEM SETUP

See Section 4.1 for instructions on how to put the ball and beam plant together. Then, go through the calibration procedure in Section 4.2 before performing the laboratory.

4.1 Assembly

Follow this procedure to setup the Ball and Beam module for experimental use:

1. Before beginning, ensure the SRV02 is setup in the high-gear configuration as detailed in [2].
2. Lay the calibration base, component #11 in Figure 2.1, flat on a table surface.
3. As pictured in Figure 4.1, place the SRV02 on its side such that the potentiometer gear fits into the cut-out section of the calibration base. Notice that the top gear of the SRV02 should be the small 24-tooth motor pinion gear.

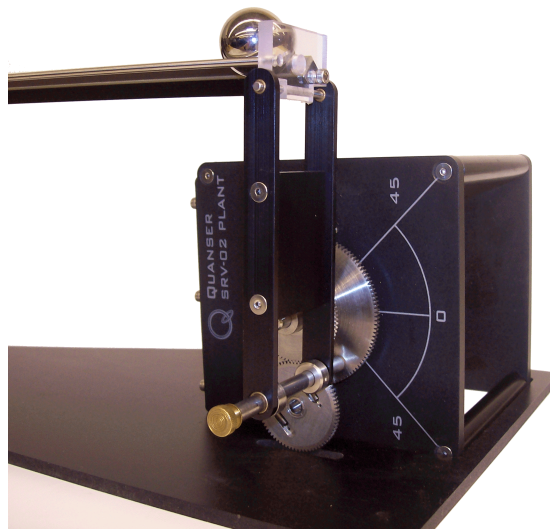

Figure 4.1: Setting up the SRV02-side of the BB01 plant

4. Fasten the coupling screw, component #3, into the screw hole of the large 120-tooth load gear as depicted in Figure 4.1.
5. Place the support base of the ball and beam, component #8 into the cut-out section of the base, as pictured in Figure 2.1.

4.2 Calibration

Once the BB01 is setup, follow this procedure to calibrate the beam:

1. As illustrated in Figure 4.2, use an 9/64 Allen Key to loosen the screws on the support arm.
2. As illustrated in Figure 4.3, manually rotate the servo load gear to the 0 degree position. The coupling screw should be aligned with the 0 degree position on the servo.



Figure 4.2: Tighten support arm screws once beam is balanced

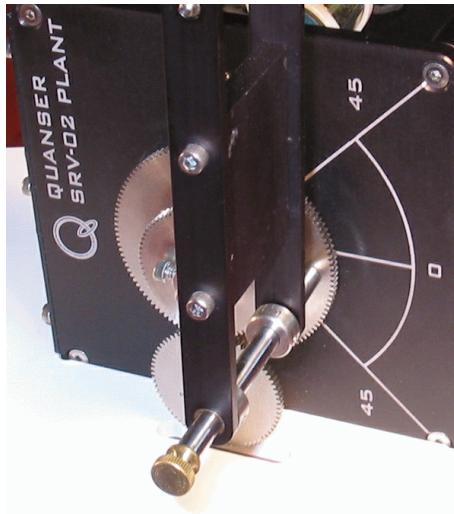

Figure 4.3: Move SRV02 load gear to 0 degree position

3. While holding the load gear at 0 degrees, place the ball in the center of the beam and vary the height of the support arm, component #7, such that the beam is approximately horizontal and the ball does not move. The balanced system is shown in Figure 4.4.
4. Once the ball is balanced, tighten the screws on the support arm, as illustrated in Figure 4.2, to finalize the calibration of the BB01 experiment.



Figure 4.4: BB01 is calibrated when the centered ball is balanced on the beam while the SRV02 is at 0 degrees

5 WIRING PROCEDURE

The following is a listing of the hardware components used in this experiment:

- **Power Amplifier:** Quanser VoltPAQ-X1, or equivalent.
- **Data Acquisition Board:** Quanser QPID, QPIDe, Q8-USB, Q2-USB, or equivalent.
- **Rotary Servo Plant:** Quanser SRV02-ET, SRV02-ETS, or equivalent.
- **Ball and Beam:** Quanser BB01 Module
- **Remote Sensor:** Quanser SS01 Module

See the corresponding documentation for more information on these components. The cables supplied with the SRV02 are described in Section 5.1 and the procedure to connect the above components is given in Section 5.2.

■ **Caution:** When using the Quanser VoltPAQ-X1 power amplifier, **make sure you set the Gain to 1!**

5.1 Cable Nomenclature

The cables used to connect the Quanser SRV02 system with a power amplifier and data-acquisition device is shown in Table 5.1. Depending on your configuration, not all these cables may be necessary.

5.2 Connections using VoltPAQ-X1

This section describes the typical connections used to connect the SRV02 plant to a data-acquisition board and a single-channel power amplifier. The connections are described in detail in the procedure below, summarized in Table 5.2, and pictured in Figure 5.1.

Note: The data-acquisition device used in Figure 5.1 is representative for any DAQ device. For example, if you are using a DAQ with 8 analog input/output channels (e.g., like the Quanser QPID or QPIDe), then the same connection are performed.

Follow these steps to connect the SRV02 system:

1. Make sure that your data-acquisition device is installed and is operational. For example, see [3] if the Quanser Q2-USB will be used.
2. Make sure everything is powered off before making any of these connections. This includes turning off your PC and the amplifier.
3. Connect one end of the 2xRCA to 2xRCA cable from the Analog Output Channel #0 on the terminal board to the *Amplifier Command* connector on the amplifier, i.e. use both white or both red RCA connectors. See cable #1 shown in Figure 5.1. This carries the attenuated motor voltage control signal, V_m/K_a , where K_a is the amplifier gain.
4. Connect the 4-pin-stereo-DIN to 6-pin-stereo-DIN cable from *To Load* connector on the amplifier to the *Motor* connector on the SRV02. See connection #2 shown in Figure 5.1. The cable transmits the amplified voltage that is applied to the SRV02 motor and is denoted V_m .
5. Connect the 5-pin-stereo-DIN to 5-pin-stereo-DIN cable from the *Encoder* connector on the SRV02 panel to Encoder Input # 0 on the terminal board, as depicted by connection #3 in Figure 5.1. This carries the load shaft angle measurement and is denoted by the variable θ_i .





Cable	Type	Description
 <p>(a) RCA Cable</p>	2xRCA to 2xRCA	This cable connects an analog output channel on the data acquisition board to the power amplifier for amplification.
 <p>(b) Motor Cable</p>	4-pin-DIN to 6-pin-DIN	This cable connects the output of the power amplifier to the dc motor on the servo.
 <p>(c) Encoder Cable</p>	5-pin-stereo-DIN to 5-pin-stereo-DIN	This cable carries the encoder signals between an encoder connector and the data acquisition board (to the encoder counter). Namely, these signals are: +5 VDC power supply, ground, channel A, and channel B
 <p>(d) Analog Cable</p>	6-pin-mini-DIN to 6-pin-mini-DIN	This cable carries analog signals (e.g., from a potentiometer) to the amplifier, where the signals can be either monitored and/or used by a controller. The cable also carries a ± 12 VDC line from the amplifier in order to power a sensor and/or signal conditioning circuitry.
 <p>(e) 5-pin-DIN to 4xRCA</p>	5-pin-DIN to 4xRCA	This cable carries the analog signals, unchanged, from the amplifier to the Analog-To-Digital input channels on the data acquisition terminal board.

Table 5.1: Cables used to connect SRV02 to amplifier and DAQ device

Cable #	From	To	Signal
1	Terminal Board: DAC #0	Amplifier <i>Amplifier Command</i> connector	Connects control signal from Analog Output #0 on DAQ device to the power amplifier.
2	Amplifier: <i>To Load</i> connector	SRV02 <i>Motor</i> connector	Power leads to the SRV02 dc motor.
3	Terminal Board: Encoder Input #0	SRV02 <i>Encoder</i> connector	Encoder load shaft angle measurement.
4	Amplifier: <i>To ADC</i> connector	Terminal Board: <ul style="list-style-type: none"> • S3 to ADC #0 • S4 to ADC #1 	Connects BB01 and Remote Sensor (SS01) ball position measurement to analog input channels #0 and #1 on the DAQ device.
5	Amplifier S3 connector	BB01 Ball Position Sensor connector	Ball and Beam (BB01) ball position measurement.
6	Amplifier S4 connector	SS01 Ball Position Sensor connector	Remote Sensor (SS01) ball position measurement.

Table 5.2: BB01 Wiring

Note: In this setup, it is assumed the SRV02 encoder is used for position feedback (i.e., not using the potentiometer).

■ **Caution:** Any encoder should be directly connected to the data-acquisition terminal board (or equivalent) using a standard 5-pin DIN cable. **DO NOT connect the encoder cable to the amplifier!**

6. Connect the *To ADC* socket on the amplifier to Analog Inputs #0-1 on the terminal board using the 5-pin-DIN to 4xRCA cable. Connect the red (S3) RCA connector to Analog Input Channel #0 and the black (S4) RCA connector to Analog Input Channel #1. **Note:** The RCA cables may not be labeled S1, S2, S3, and S4. In that case, use the colour convention yellow (S1), white (S2), red (S3), black (S4).
7. Connect the *Ball Position Sensor* connector from the BB01 to the S3 socket on the amplifier using the 6-pin-mini-DIN to 6-pin-mini-DIN cable. See connection #5 in Figure 5.1. This carries the the measured ball position from the beam potentiometer and is denoted by variable x .
8. If the SS01 remote sensor module (shown in Figure 2.2) is used, then connect *Remote Ball Position Sensor* connector from the SS01 remote sensor module to the S4 socket on the amplifier using the 6-pin-mini-DIN to 6-pin-mini-DIN cable. See connection #6 in Figure 5.1. This measures the ball position on the remote sensor and is denoted by x_d .

5.3 Connections with the VoltPAQ-X2

Because the VoltPAQ-X2 has no analog input connectors, users must interface their BB01 and SS01 sensors through the Analog Signal Conditioner box. The amplifier also has to be enabled through the digital output lines. The wiring is illustrated in Figure 5.2 and explained in Table 5.3.

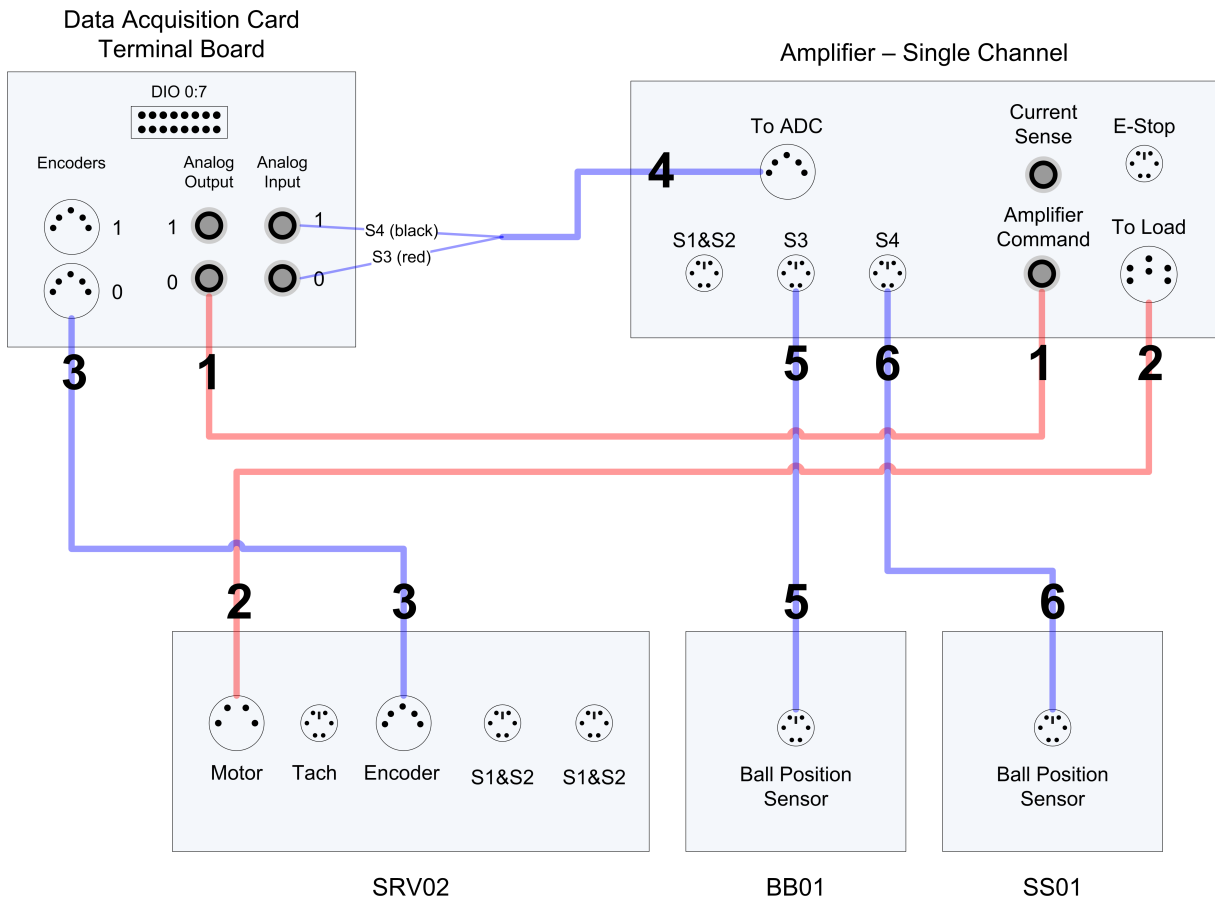

Figure 5.1: BB01 connections using generic DAQ with a single-channel amplifier

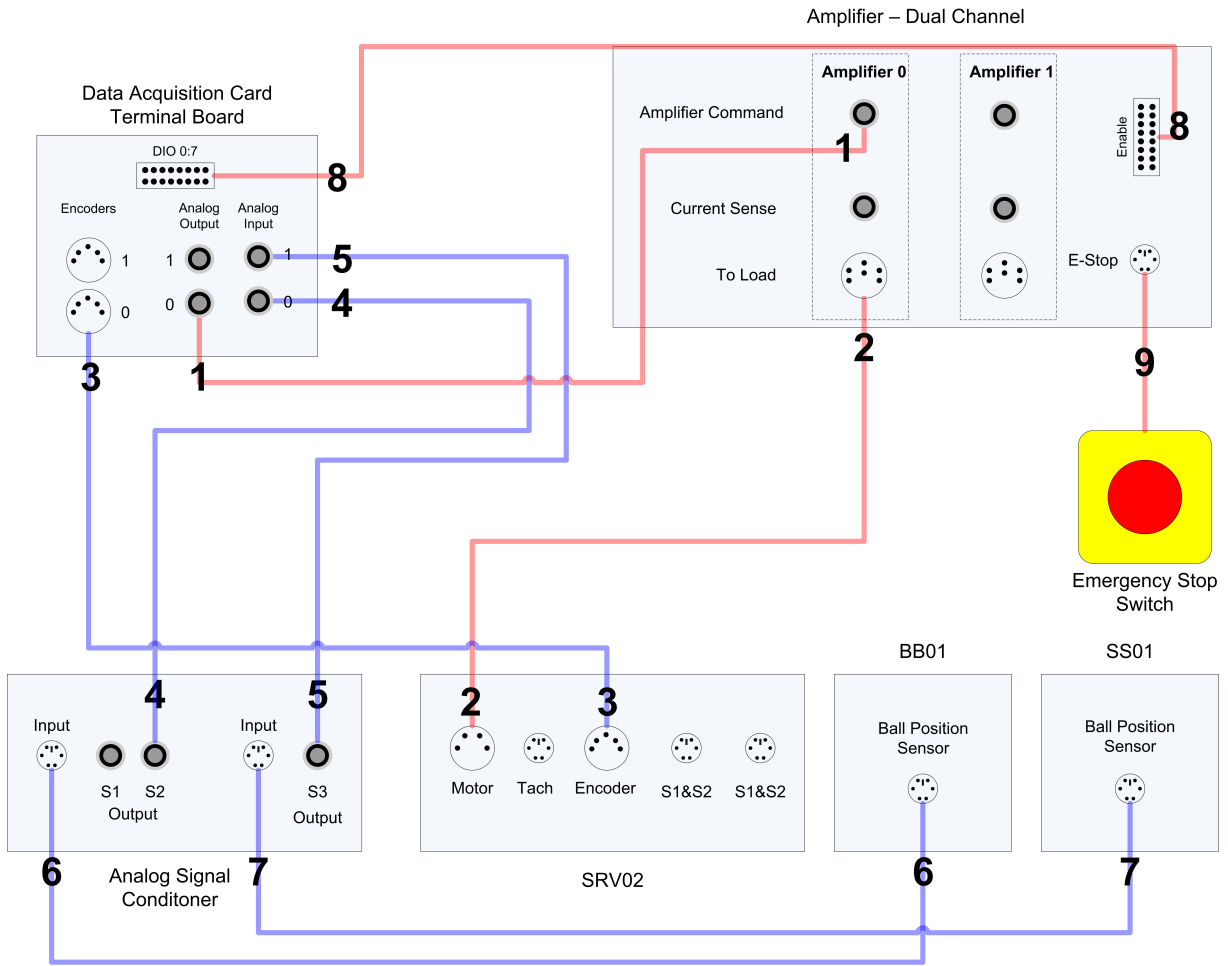

Figure 5.2: BB01 connections when using the VoltPAQ-X2

Cable #	From	To	Signal
1	Terminal Board: DAC #0	Amplifier <i>Amplifier</i> <i>Command</i> connector	Connects control signal from Analog Output #0 on the DAQ device to the power amplifier.
2	Amplifier: <i>To Load</i> connector	SRV02 <i>Motor</i> connector	Power leads to the SRV02 dc motor.
3	Terminal Board: Encoder Input #0	SRV02 <i>Encoder</i> connector	Encoder load shaft angle measurement.
4	Signal Conditioner Box S2 connector	Terminal Board: ADC #0	Connects BB01 ball position measurement to Analog Input #0 on data-acquisition board.
5	Signal Conditioner Box S3 connector	Terminal Board: ADC #1	Connects Remote Sensor (SS01) ball position measurement to Analog Input #1 on the data-acquisition board.
6	Signal Conditioner Box <i>Input 1</i> connector	BB01 Ball Position Sensor connector	BB01 ball position measurement.
7	Signal Conditioner <i>Input 2</i> connector	SS01 Ball Position Sensor connector	SS01 ball position measurement.
8	Terminal Board: <i>DIO 1</i> Header	Amplifier <i>Enable</i> Connector	Enables the amplifier channels
9	Amplifier <i>E-Stop</i> Connector	E-Stop switch	When E-Stop is pressed down, the amplifier is deactivated. Must be in released position for amplifier to become enabled.

Table 5.3: BB01 Wiring using VoltPAQ-X2

6 TESTING AND TROUBLESHOOTING

This section describes some functional tests to determine if the Ball and Beam system is operating properly. It is assumed that the system is connected as described in the Section 5, above. To carry out these tests, it is preferable if the user uses a software such as **QUARC®** or **LabVIEW®** to read sensor measurements and output voltages to the motor. See Reference [1] to learn how to interface the SRV02 with QUARC. Alternatively, these tests can be performed with a signal generator and an oscilloscope.

6.1 SRV02 Motor and Encoder

See [2] for information on testing and troubleshooting the SRV02 separately.

6.2 Ball Position Sensor

6.2.1 Testing

Test the ball position sensor from the BB01 or SS01 with the following procedure:

1. Measure analog input channel #2 to test the BB01 sensor or analog input channel #3 to test the SS01 sensor (unless the sensors are connected on a different channels).
2. A typical signal response of the ball position sensor is illustrated in Figure 6.1. For the BB01, the ball position sensor should output a voltage of about 4.5 V when it is closest to the SRV02. As the ball is rolled away from the SRV02 the measured voltage signal should be decreasing down to approximately -4.5 V when the ball reaches the other end of the beam.
■ Caution: Sometimes when the ball is sitting at the very end of the beam it may not be in contact with the sensor. In this case the reading will initially be 0 V but when the ball begins moving the sensor signal will jump up to about 4.5 V and then begin decreasing.
3. Beside the ends of the beam, the signal should have no discontinuities and little noise. Similarly for the SS01 sensor, the voltage signal should decreasing from approximately 4.5 V to -4.5 V as the ball travels towards the end of the beam with the analog connector.

6.2.2 Troubleshooting

Follow the steps below if the potentiometer is not measuring correctly:

- Verify that the power amplifier is functional. For example when using the Quanser VoltPAQ device, is the green LED lit? Recall the analog sensor signal go through the amplifier before going to the data-acquisition device (except when using the Q3 ControlPAQ). Therefore the amplifier needs to be turned on to read the potentiometer.
- Check that the data-acquisition board is functional, e.g. ensure it is properly connected, that the fuse is not burnt.
- Measure the voltage across the potentiometer. Ensure the potentiometer is powered with a ± 12 V at the 6-pin-mini DIN connector on the BB01, component #10 in Figure 2.1, or on the SS01, component #14 in Figure 2.2. The two bottom pins of the DIN connector are GND pins and the leftmost pin, i.e. where the green cable is connected to, outputs the voltage of the ball.

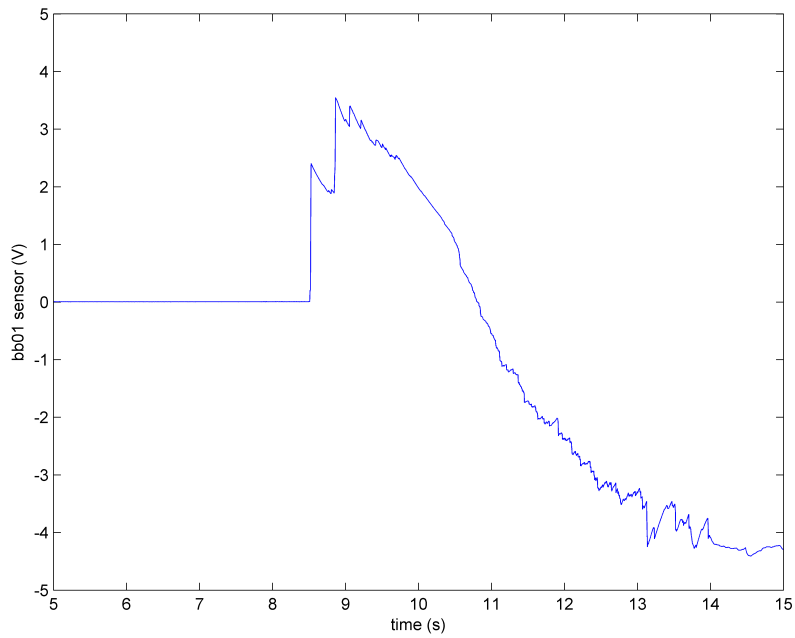

Figure 6.1: Typical voltage signal measured by the BB01 ball position sensor

- Using a voltmeter, connect one probe to the middle-left pin and the other to the bottom GND pins. The voltage should vary between about ± 4.5 V as the ball position is changed. Please see Section 7 for information on contacting Quanser for technical support.

7 TECHNICAL SUPPORT

To obtain support from Quanser, go to <http://www.quanser.com/> and click on the Tech Support link. Fill in the form with all the requested software and hardware information as well as a description of the problem encountered. Also, make sure your e-mail address and telephone number are included. Submit the form and a technical support person will contact you.

REFERENCES

- [1] Quanser Inc. *SRV02 QUARC Integration*, 2008.
- [2] Quanser Inc. *SRV02 User Manual*, 2009.
- [3] Quanser Inc. *Q2-USB Data-Acquisition System User's Guide*, 2010.

The modular control lab that expands to fit your requirements



With the SRV02 Base Unit, you can select from 10 add-on modules to create experiments of varying complexity across a wide range of topics, disciplines and courses. All of the experiments/workstations are compatible with LabVIEW™.

To request a demonstration, please email info@quanser.com.

©2011 Quanser Inc. All rights reserved. LabVIEW™ is a trademark of National Instruments.



INFO@QUANSER.COM

+1-905-940-3575

QUANSER.COM

Solutions for teaching and research. Made in Canada.